

Fieldbus Master Unit

Hardware Manual

PFXZCHEUFNCAM-MM01-EN_01
06/2021

The information provided in this documentation contains general descriptions and/or technical characteristics of the performance of the products contained herein. This documentation is not intended as a substitute for and is not to be used for determining suitability or reliability of these products for specific user applications. It is the duty of any such user or integrator to perform the appropriate and complete risk analysis, evaluation and testing of the products with respect to the relevant specific application or use thereof. Neither Schneider Electric nor any of its affiliates or subsidiaries (hereinafter, referred to as Schneider Electric) shall be responsible or liable for misuse of the information that is contained herein. If you have any suggestions for improvements or amendments or have found errors in this publication, please notify us.

You agree not to reproduce, other than for your own personal, noncommercial use, all or part of this document on any medium whatsoever without permission of Schneider Electric, given in writing. You also agree not to establish any hypertext links to this document or its content. Schneider Electric does not grant any right or license for the personal and noncommercial use of the document or its content, except for a non-exclusive license to consult it on an "as is" basis, at your own risk. All other rights are reserved.

All pertinent state, regional, and local safety regulations must be observed when installing and using this product. For reasons of safety and to help ensure compliance with documented system data, only the manufacturer should perform repairs to components.

When devices are used for applications with technical safety requirements, the relevant instructions must be followed.

Failure to use Schneider Electric software or approved software with our hardware products may result in injury, harm, or improper operating results.

Failure to observe this information can result in injury or equipment damage.

Copyright © 2021 Schneider Electric Japan Holdings Ltd. All Rights Reserved.

Table of Contents



	Safety Information	5
	About the Book.	7
Chapter 1	Overview	9
	Package Contents	10
	Certifications and Standards	11
	Federal Communication Commission Radio Frequency Interference Statement - For USA	13
	Hazardous Location Installation - For USA and Canada	14
	European (CE) Compliance and KC Markings	16
Chapter 2	Device Connectivity	17
	System Design	18
	Accessories	20
Chapter 3	Parts Identification and Functions	21
	Parts Identification	22
	LED Indications	24
Chapter 4	Specifications	25
4.1	General Specifications	26
	Electrical Specifications	27
	Environmental Specifications	28
	Structural Specifications	29
4.2	Functional Specifications	30
	Transmission Specifications	30
4.3	Interface Specifications	31
	Interface Connection	32
	Fieldbus Interfaces	33
Chapter 5	Dimensions	35
	External Dimensions	36
	Dimensions with Cables	37
Chapter 6	Installation and Wiring.	39
	Installation	40
	Wiring the FLEX NETWORK Connector	42
	CANopen cable arrangement	43
	Installation Precautions	45
Chapter 7	After-sales Service	47
	After-sales Service	47

Safety Information



Important Information

NOTICE

Read these instructions carefully, and look at the equipment to become familiar with the device before trying to install, operate, or maintain it. The following special messages may appear throughout this documentation or on the equipment to warn of potential hazards or to call attention to information that clarifies or simplifies a procedure.



The addition of this symbol to a “Danger” or “Warning” safety label indicates that an electrical hazard exists which will result in personal injury if the instructions are not followed.



This is the safety alert symbol. It is used to alert you to potential personal injury hazards. Obey all safety messages that follow this symbol to avoid possible injury or death.

DANGER

DANGER indicates a hazardous situation which, if not avoided, **will result in** death or serious injury.

WARNING

WARNING indicates a hazardous situation which, if not avoided, **could result in** death or serious injury.

CAUTION

CAUTION indicates a hazardous situation which, if not avoided, **could result in** minor or moderate injury.

NOTICE

NOTICE is used to address practices not related to physical injury.

PLEASE NOTE

Electrical equipment should be installed, operated, serviced, and maintained only by qualified personnel. No responsibility is assumed by Schneider Electric for any consequences arising out of the use of this material.

A qualified person is one who has skills and knowledge related to the construction and operation of electrical equipment and its installation, and has received safety training to recognize and avoid the hazards involved.

About the Book



At a Glance

Document Scope

This manual describes how to use this product.

Validity Note

This documentation is valid for this product.

The technical characteristics of the device(s) described in this manual also appear online at <http://www.pro-face.com>.

The characteristics presented in this manual should be the same as those that appear online. In line with our policy of constant improvement we may revise content over time to improve clarity and accuracy. In the event that you see a difference between the manual and online information, use the online information as your reference.

Registered Trademarks

Microsoft and Windows are registered trademarks of Microsoft Corporation in the United States and/or other countries.

Product names used in this manual may be the registered trademarks owned by the respective proprietors.

Related Documents

You can download the manuals related to this product, such as the software manual, from our support site at <http://www.pro-face.com/trans/en/manual/1001.html>.

Product Related Information

If the equipment is used in a manner not specified by the manufacturer, the protection provided by the equipment may be impaired.

In the event this product does not run properly due to whatever reason, it may be difficult or impossible to identify a function. Functions that may present a hazard if not immediately executed, such as a fuel shut-off, must be provided independently of this product. The machine's control system design must take into account the operator being unable to control the machine or making mistakes in the control of the machine.

WARNING

UNINTENDED EQUIPMENT OPERATION

The application of this product requires expertise in the design and programming of control systems. Only persons with such expertise should be allowed to program, install, alter, and apply this product.

Follow all local and national safety standards.

Failure to follow these instructions can result in death, serious injury, or equipment damage.

For additional information, refer to NEMA ICS 1.1 (latest edition), "Safety Guidelines for the Application, Installation, and Maintenance of Solid State Control" and to NEMA ICS 7.1 (latest edition), "Safety Standards for Construction and Guide for Selection, Installation and Operation of Adjustable-Speed Drive Systems" or their equivalent governing your particular location.

Chapter 1

Overview

What Is in This Chapter?

This chapter contains the following topics:

Topic	Page
Package Contents	10
Certifications and Standards	11
Federal Communication Commission Radio Frequency Interference Statement - For USA	13
Hazardous Location Installation - For USA and Canada	14
European (CE) Compliance and KC Markings	16

Package Contents

Package Contents

NOTE: This product has been carefully packed with special attention to quality. However, should you find anything damaged or missing, please contact your local distributor immediately.

Verify all items listed here are present in your package:

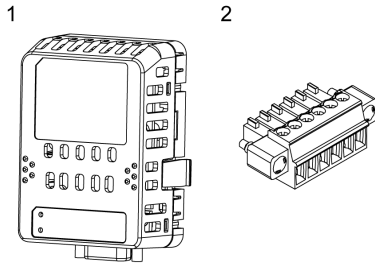

- 1 One of the following products: 1
 - FLEX NETWORK Master Unit (model number: PFXZCHEUFN1)
 - CANopen Master Unit (model number: PFXZCHEUCAM1)
- 2 FLEX NETWORK Connector (model number: PFXZCHCNFN2): 1 (FLEX NETWORK Master Unit only)
- 3 Installation Guide: 1
- 4 Chinese RoHS flyer: 1

Revision

You can identify the product version (PV), revision level (RL), and the software version (SV) from the product label.

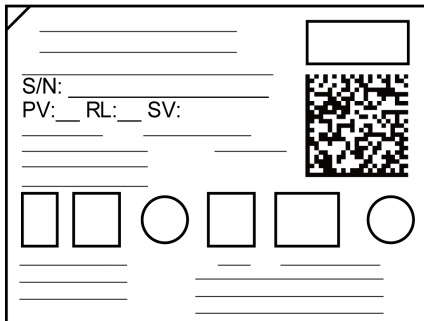

Certifications and Standards

Some products are not subject to certification and standards. And some products have not received their certification and standards but are scheduled for assessment.

The certifications and standards listed below may include those that are not yet acquired for this product. For the latest certifications and standards that this product has acquired, please check the product marking or the following URL.

<http://www.pro-face.com/trans/en/manual/1002.html>

Agency Certifications

Schneider Electric submitted this product for independent testing and qualification by third-party listing agencies. These agencies have certified this product as meeting the following standards.

- Underwriters Laboratories Inc., UL 61010-2-201 and CSA C22.2 N°61010-2-201, Industrial Control Equipment
- Underwriters Laboratories Inc., ANSI/ISA 12.12.01 and CSA C22.2 N°213, Electrical Equipment for Use in Class I, Division 2 Hazardous (Classified) Locations
- IECEx/ATEX for use in zones 2/22
- EAC certification (Russia, Belarus, Kazakhstan)

Compliance Standards

Europe:

CE

- Directive 2014/35/EU (Low Voltage)
- Directive 2014/30/EU (EMC)
 - Programmable Controllers: EN 61131-2
 - EN61000-6-4
 - EN61000-6-2
- Directive 2014/34/EU (ATEX)
 - EN60079-0
 - EN60079-15
 - EN60079-31

Australia:

RCM

- EN61000-6-4

Korea:

KC

- KN11
- KN61000-6-2

Qualifications Standards

Schneider Electric voluntarily tested this product to additional standards. The additional tests performed, and the standards under which the tests were conducted, are specifically identified in General Specifications (*see page 26*).

Hazardous Substances

This product is a device for use in factory systems. When using this product in a system, the system should comply with the following standards in regards to the installation environment and handling:

- WEEE, Directive 2012/19/EU
- RoHS, Directive 2011/65/EU and 2015/863/EU
- RoHS China, Standard GB/T 26572
- REACH regulation EC 1907/2006

Unit Disposal

When disposing this product, dispose it in a manner appropriate to, and in accordance with, your country's industrial machinery disposal/recycling standards.

Federal Communication Commission Radio Frequency Interference Statement - For USA

FCC Radio Interference Information

This product has been tested and found to comply with the Federal Communications Commission (FCC) limits for a Class A digital device, pursuant to Part 15 of the FCC Rules. These limits are designed to provide reasonable protection against harmful interference in a commercial, industrial or business environment. This product generates, uses, and can radiate radio frequency energy and, if not installed and used in accordance with the instructions, may cause or be subject to interference with radio communications. To minimize the possibility of electromagnetic interference in your application, observe the following two rules:

- Install and operate this product in such a manner that it does not radiate sufficient electromagnetic energy to cause interference in nearby devices.
- Install and test this product to ensure that the electromagnetic energy generated by nearby devices does not interfere with the operation of this product.
- Changes or modifications not expressly approved by the party responsible for compliance could void the user's authority to operate this product.

WARNING

ELECTROMAGNETIC / RADIO INTERFERENCE

Electromagnetic radiation may disrupt the operation of this product leading to unintended equipment operation. If electromagnetic interference is detected:

- Increase the distance between this product and the interfering equipment.
- Reorient this product and the interfering equipment.
- Reroute power and communication lines to this product and the interfering equipment.
- Connect this product and the interfering equipment to different power supplies.
- Always use shielded cables when connecting this product to a peripheral device or another computer.

Failure to follow these instructions can result in death, serious injury, or equipment damage.

Hazardous Location Installation - For USA and Canada

General

This product has been designed with the intention of meeting the requirements of Class I, Division 2 hazardous location application. Division 2 locations are those locations where ignitable concentrations of flammable substances are normally confined, prevented by ventilation, or present in an adjacent Class I, Division 1 location, but where an abnormal situation might result in intermittent exposure to such ignitable concentrations.

While this product is a non-incendive device under ANSI/ISA 12.12.01 and CSA C22.2 N°213, it is not designed for, and should never be used within a Division 1 (normally hazardous) location.

This product is suitable for use in Class I, Division 2, Groups A, B, C, and D hazardous locations or in non-hazardous locations. Before installing or using this product, confirm that the ANSI/ISA 12.12.01 or CSA22.2 N°213 certification appears on the product labeling.

NOTE: Some products are not yet rated as suitable for use in hazardous locations. Always use your product in conformance with the product labeling and this manual.

DANGER

POTENTIAL FOR EXPLOSION

- Do not use this product in hazardous environments or locations other than Class I, Division 2, Groups A, B, C, and D.
- Substitution of any component may impair suitability for Class I, Division 2.
- Do not disconnect equipment unless power has been switched off or the area is known to be non-hazardous.
- Always confirm that this product is suitable for use in hazardous locations by checking the ANSI/ISA 12.12.01 or CSA C22.2 N°213 certification appears on the product labeling.
- Do not install any Pro-face or OEM components, equipment, or accessories unless these have also been qualified as suitable for use in Class I, Division 2, Groups A, B, C, and D locations.
- Do not attempt to install, operate, modify, maintain, service, or otherwise alter this product except as permitted in this manual. Unpermitted actions may impair the suitability of this product for Class I, Division 2 operation.

Failure to follow these instructions will result in death or serious injury.

DANGER

POTENTIAL FOR EXPLOSION

- Always confirm the ANSI/ISA 12.12.01 or CSA C22.2 N°213 hazardous location rating of your device before installing or using it in a hazardous location.
- Do not connect or disconnect equipment unless power has been switched off or the area is known to be non-hazardous. This applies to all connections including power, ground, serial, parallel, and network connections.
- Never use unshielded / ungrounded cables in hazardous locations.
- When enclosed, keep enclosure doors and openings closed at all times to avoid the accumulation of foreign matter inside the workstation.

Failure to follow these instructions will result in death or serious injury.

Make sure that this product is properly rated for the location. If the intended location does not presently have a Class, Division and Group rating, then users should consult the appropriate authorities having jurisdiction in order to determine the correct rating for that hazardous location.

Operation and Maintenance

The systems have been designed for compliance with relevant spark ignition tests.

 DANGER**POTENTIAL FOR EXPLOSION**

In addition to the other instructions in this manual, when installing this product in a hazardous location, wire the equipment in accordance with the National Electrical Code article 501.10 (B) for Class I, Division 2 hazardous locations.

Failure to follow these instructions will result in death or serious injury.

European (CE) Compliance and KC Markings

CE Compliance Note

The product described in this manual comply with the European Directives concerning Electromagnetic Compatibility and Low Voltage (CE marking) when used as specified in the relevant documentation, in application for which they are specifically intended, and in connection with approved third-party products.

KC Markings

사용자안내문

기종별	사용자안내문
A급 기기 (업무용 방송통신기자재)	이 기기는 업무용(A급) 전자파적합기기로서 판매자 또는 사용자는 이 점을 주의하시기 바라며, 가정외의 지역에서 사용하는 것을 목적으로 합니다.

Chapter 2

Device Connectivity

What Is in This Chapter?

This chapter contains the following topics:

Topic	Page
System Design	18
Accessories	20

System Design

This product is an accessory for the SP5000 Series.

By attaching this product to the SP5000 Series Power Box, you can communicate with slave devices on the fieldbus network.

NOTE: For model numbers of the Power Box, refer to the SP5000 Series Hardware Manual.

FLEX NETWORK Master Unit

By attaching this product to the Box Module, you can communicate with FLEX NETWORK I/O and the Analog Unit.

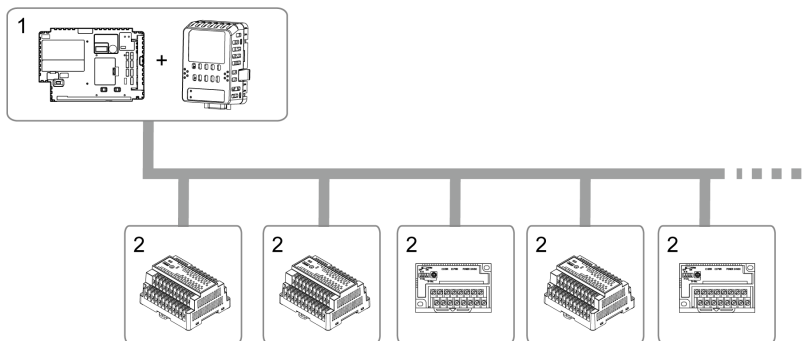

1 FLEX NETWORK Master Unit + SP5000 Series Power Box

2 FLEX NETWORK I/O or Analog Unit*¹

*¹ For supported models, refer to our site at <http://www.pro-face.com>.

CANopen Master Unit

By attaching this product to the Box Module, you can join a CANopen network to communicate with CANopen slave equipment.

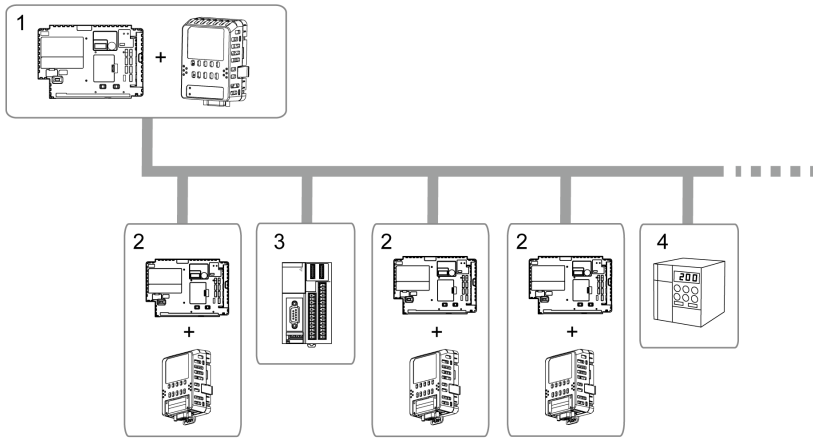

- 1 CANopen Master Unit + SP5000 Series Power Box
- 2 CANopen Slave Unit^{*1} + SP5000 Series Power Box
- 3 Pro-face Hybrid Terminal Block (HTB)^{*1}
- 4 Other CANopen slave equipment^{*1}

*1 For supported models, refer to our site at <http://www.pro-face.com>.

Accessories

Product name	Product number	Description
FLEX NETWORK Communication Cable	FN-CABLE2050-31-MS (50 m)	Cable for connecting FLEX NETWORK Master Unit with FLEX NETWORK I/O or Analog Unit.
	FN-CABLE2200-31-MS (200 m)	

Maintenance Accessories

Product name	Product number	Description
FLEX NETWORK Connector	PFXZCHCNFN2	Connector attached to FLEX NETWORK Master Unit (5 pieces/set)

Chapter 3

Parts Identification and Functions

What Is in This Chapter?

This chapter contains the following topics:

Topic	Page
Parts Identification	22
LED Indications	24

Parts Identification

FLEX NETWORK Master Unit

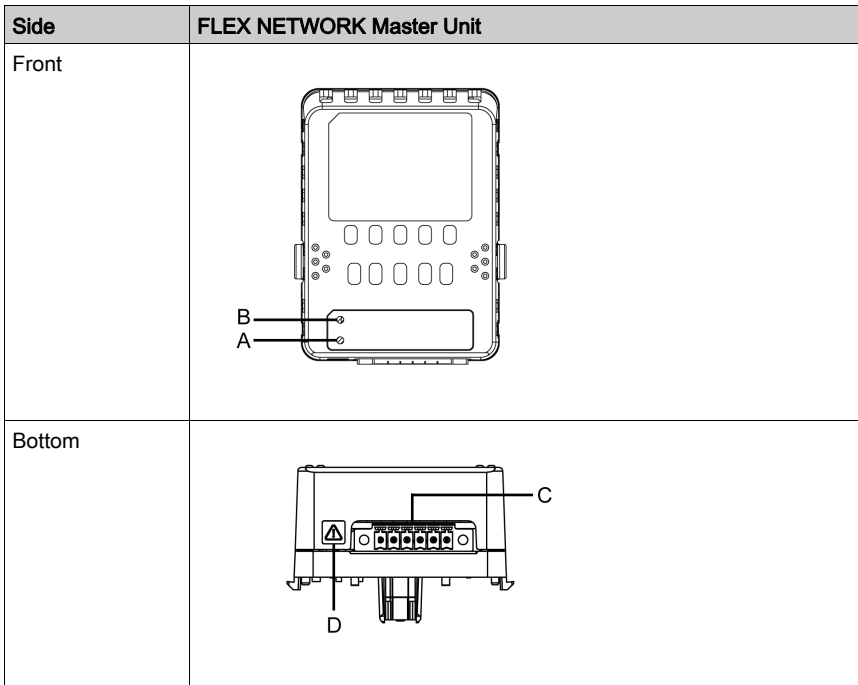

Part	Name	Description
A	Status LED	<i>(see page 24)</i>
B	Status LED	
C	FLEX NETWORK interface	-
D	Alert symbol	This symbol identifies safety messages and notes about Wiring the FLEX NETWORK Connector <i>(see page 42)</i> .

CANopen Master Unit

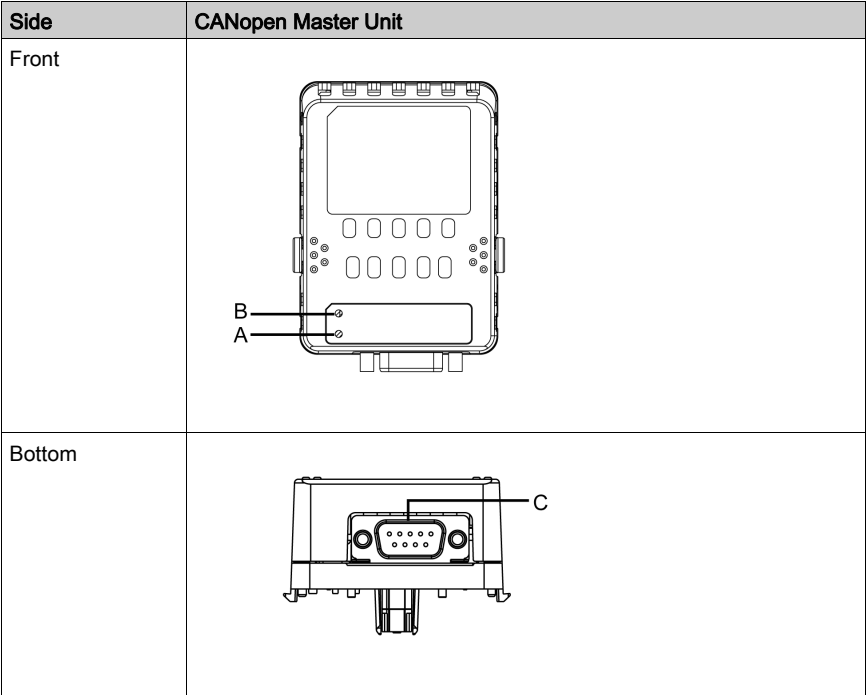

Part	Name	Description
A	Status LED	(see page 24)
B	Status LED	
C	CANopen interface	-

LED Indications

FLEX NETWORK

Status LED				
Position	LED name	Color	Indicator	Description
A	RUN	Green	ON	Turns on when communication is enabled.
B	ERR	Red	ON	Turns on when failure occurs in connected I/O unit.

CANopen

Status LED				
Position	LED name	Color	Indicator*1	Description
A	RUN	Green	ON	Operational
			Blinking	Pre-operational
			Single flash	Stopped
B	ERR	Red	OFF	No error
			ON	Bus off
			Blinking	Invalid configuration
			Single flash	Warning limit reached
			Double flash	Guard/heartbeat event

*1 The following illustrates the flash cycle.

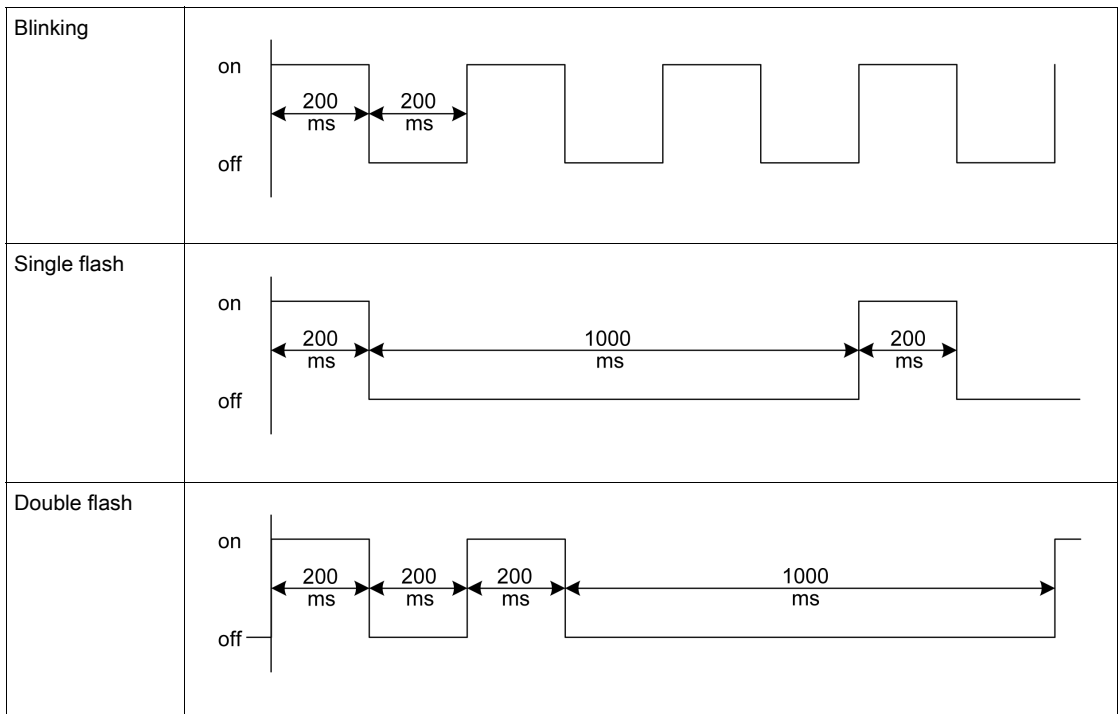

Chapter 4

Specifications

What Is in This Chapter?

This chapter contains the following sections:

Section	Topic	Page
4.1	General Specifications	26
4.2	Functional Specifications	30
4.3	Interface Specifications	31

Section 4.1

General Specifications

What Is in This Section?

This section contains the following topics:

Topic	Page
Electrical Specifications	27
Environmental Specifications	28
Structural Specifications	29

Electrical Specifications

Power supply	Rated input voltage	3.3 Vdc (Supplied by the SP5000 Series Power Box)
	Power consumption	0.4 W or less
Voltage endurance		500 Vac, 20 mA for 1 minute (between SG terminal and FG terminal)
Insulation resistance		500 Vdc, 100 M Ω or more (between SG terminal and FG terminal)

Environmental Specifications

Physical environment	Ambient air temperature	0...60 °C (32...140 °F)
	Storage temperature	-20...60 °C (-4...140 °F)
	Ambient air and storage humidity	10%...90% RH (non-condensing, wet bulb temperature 39 °C [102.2 °F] or less)
	Dust	0.1 mg/m ³ (10 ⁻⁷ oz/ft ³) or less (non-conductive levels)
	Pollution degree	For use in Pollution Degree 2 environment
	Corrosive gases	Free of corrosive gases
	Atmospheric pressure (operating altitude)	800...1,114 hPa (2,000 m [6,561 ft] or lower)
Mechanical environment	Vibration resistance	IEC/EN 61131-2 compliant 5...9 Hz single amplitude 3.5 mm (0.14 in) 9...150 Hz fixed acceleration: 9.8 m/s ² X, Y, Z directions for 10 cycles (approximately 100 minutes)
	Shock resistance	IEC/EN 61131-2 compliant 147 m/s ² , X, Y, Z directions for 3 times
Electrical environment	Electrostatic discharge immunity	Contact discharge method: 6 kV Air discharge method: 8 kV (IEC/EN 61000-4-2 Level 3)

Air quality requirements

Do not operate or store the panel where chemicals evaporate, or where chemicals are present in the air:

- Corrosive chemicals: Acids, alkalines, liquids containing salt.
- Flammable chemicals: Organic solvents.

CAUTION

INOPERATIVE EQUIPMENT

Do not allow water, liquids, metal, and wiring fragments to enter inside this product.

Failure to follow these instructions can result in injury or equipment damage.

Structural Specifications

Grounding	Functional grounding: Grounding resistance of 100 Ω , 2 mm ² (AWG 14) or thicker wire, or your country's applicable standard (same for FG and SG terminals).
Cooling method	Natural air circulation
External dimensions (W x H x D)	FLEX NETWORK Master Unit: 60 x 78 x 41 mm (2.36 x 3.07 x 1.61 in) CANopen Master Unit: 60 x 82 x 41 mm (2.36 x 3.23 x 1.61 in)
Weight	FLEX NETWORK Master Unit: 80 g (2.82 oz) or less CANopen Master Unit: 90 g (3.17 oz) or less

Section 4.2

Functional Specifications

Transmission Specifications

FLEX NETWORK

Communication type	1:N
Connection method	Multi drop
Transfer distance	At 6 Mbps 200 m per CH, at 12 Mbps 100 m per CH
Transfer method	During cyclic period, distributed transmission, half-duplex
Transfer speed*1	6 Mbps, 12 Mbps
Transfer interface	Differential method, pulse transfer resistance
Error check	Format check, bit check, CRC-12 check
Number of nodes	Up to 63 nodes

CANopen

NOTE: CANopen is the networking standard based on the international standard CAN. CANopen is defined as a uniform application layer by the DS301 specifications of the CiA (CAN in Automation).

Communication type	1:N					
Connection method	Bus configuration					
Transfer method	CSMA/NBA, half-duplex serial transmission					
Transfer speed (bps)*1/	50 K	125 K	250 K	500 K	800 K	1,000 K
Transfer distance	1,000 m	500 m	250 m	100 m	40 m	20 m
Number of nodes	Up to 63 nodes					

*1 Set with the screen editing software.

Section 4.3

Interface Specifications

What Is in This Section?

This section contains the following topics:

Topic	Page
Interface Connection	32
Fieldbus Interfaces	33

Interface Connection

Cable Connections

DANGER

POTENTIAL FOR EXPLOSION

- Always confirm the ANSI/ISA 12.12.01 or CSA C22.2 N°213 hazardous location rating of your device before installing or using it in a hazardous location.
- Do not connect or disconnect equipment unless power has been switched off or the area is known to be non-hazardous. This applies to all connections including power, ground, serial, parallel, and network connections.
- Never use unshielded / ungrounded cables in hazardous locations.
- When enclosed, keep enclosure doors and openings closed at all times to avoid the accumulation of foreign matter inside the workstation.

Failure to follow these instructions will result in death or serious injury.

Division 2 hazardous location regulations require that all cable connections be provided with adequate strain relief and positive interlock. Never connect or disconnect a cable while power is applied at either end of the cable. All communication cables should include a chassis ground shield. This shield should include both copper braid and aluminum foil. The D-sub style connector housing must be a metal conductive type (for example, molded zinc) and the ground shield braid must be terminated directly to the connector housing. Do not use a shield drain wire.

The outer diameter of the cable must be suited to the inner diameter of the cable connector strain relief so that a reliable degree of strain relief is maintained. Always secure the D-sub connectors to the workstation-mating connectors via the two screws located on both sides.

DANGER

HAZARD OF ELECTRIC SHOCK, EXPLOSION, OR ARC FLASH

- Remove all power from the device before removing any covers or elements of the system, and prior to installing or removing any accessories, hardware, or cables.
- Always use a properly rated voltage sensing device to confirm power is off.
- Replace and secure all covers or elements of the system before applying power to this product.
- Be sure to ground this product's FG terminal.

Failure to follow these instructions will result in death or serious injury.

Fieldbus Interfaces

⚡ ⚠ DANGER

ELECTRIC SHOCK AND FIRE

When using the SG terminal to connect an external device to this product:

- Verify that a ground loop is not created when you set up the system.
- Connect the SG terminal to remote equipment when the external device is not isolated.
- Connect the SG terminal to a known reliable ground connection to reduce the risk of damaging the circuit.

Failure to follow these instructions will result in death or serious injury.

⚠ CAUTION

LOSS OF COMMUNICATION

- All connections to the communication ports must not put excessive stress on the ports.
- Securely attach communication cables to the panel wall or cabinet.
- Use a D-Sub 9 pin connector with jack screws.

Failure to follow these instructions can result in injury or equipment damage.

NOTE:

- Use within the rated current.
- Use only the SELV (Safety Extra-Low Voltage) circuit to connect the FLEX NETWORK and CANopen interfaces.

FLEX NETWORK Interface

Plug connector

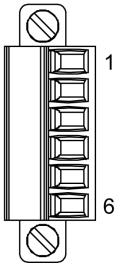
Product side	Pin No.	Signal name	Direction	Meaning
	1	TR+	I/O	CH1 communication data
	2	TR-	I/O	CH1 communication data
	3	SLD	-	CH1 cable, shielded wire
	4	TR+	I/O	CH2 communication data
	5	TR-	I/O	CH2 communication data
	6	SLD	-	CH2 cable, shielded wire

Interfit bracket is MC 1,5/6-STF-3,5 manufactured by Phoenix Contact.

CANopen Interface

D-Sub 9 pin plug connector

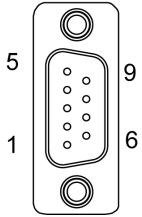
Product side	Pin No.	Signal name	Direction	Meaning
	1	NC	-	No connection
	2	CAN_L	I/O	CAN_L bus line
	3	CAN_GND	-	CAN ground
	4	NC	-	No connection
	5	NC	-	No connection
	6	CAN_GND	-	CAN ground
	7	CAN_H	I/O	CAN_H bus line
	8	NC	-	No connection
	9	NC	-	No connection
	Shell	FG	-	Functional ground

Interfit bracket is #4-40 (UNC).

Chapter 5

Dimensions

What Is in This Chapter?

This chapter contains the following topics:

Topic	Page
External Dimensions	36
Dimensions with Cables	37

External Dimensions

FLEX NETWORK Master Unit

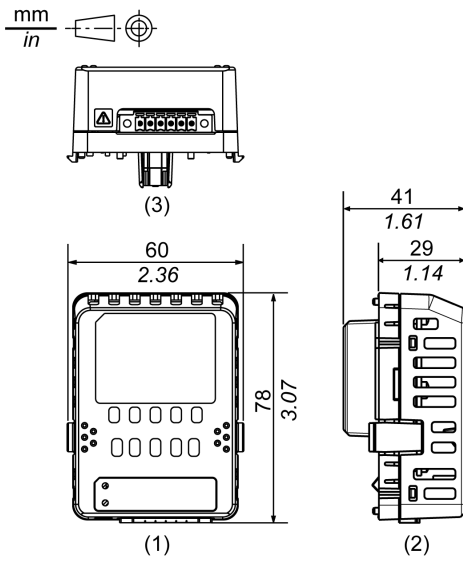

- 1 Front
- 2 Left
- 3 Bottom

CANopen Master Unit

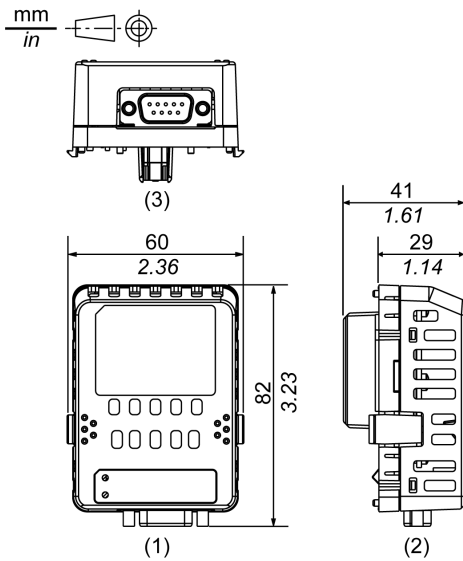

- 1 Front
- 2 Left
- 3 Bottom

Dimensions with Cables

FLEX NETWORK Master Unit

NOTE: The following illustration is of the SP-5600TP.

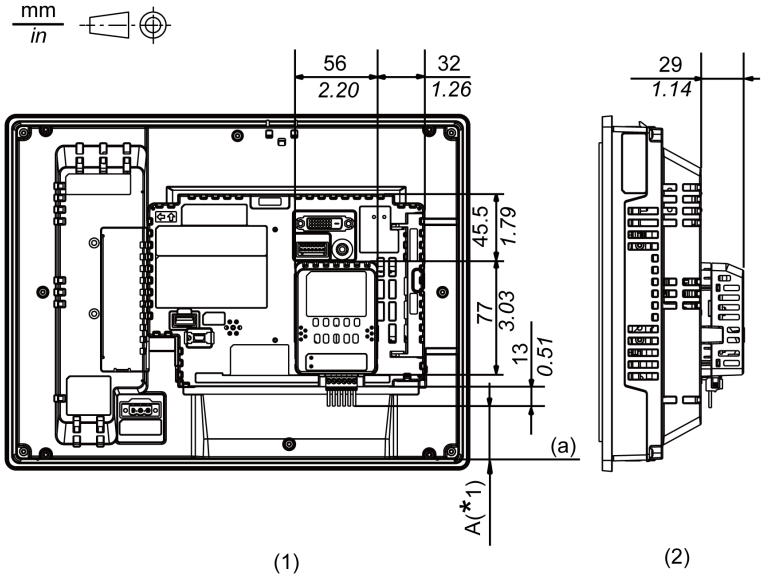

- 1 Rear
- 2 Left

*1 Refer to the following table for the length of A.

Negative when fits inside (a).

Series		Size	Model name	A
SP5000 Series	Premium Display	10 inch	SP-5500TP	-23 mm (-0.91 in)
		12 inch	SP-5600TP	-36 mm (-1.42 in)
			SP-5660TP	
		15 inch	SP-5700TP	-64 mm (-2.52 in)
		15 inch Wide	SP-5700WC	-48 mm (-1.89 in)
	19 inch Wide	SP-5800WC	-82 mm (-3.23 in)	
	Advanced Display	7 inch Wide	SP-5400WA	10 mm (0.39 in)
		10 inch Wide	SP-5500WA	-15 mm (-0.59 in)
		12 inch Wide	SP-5600WA	-31 mm (-1.22 in)

NOTE:

- All the above values are designed with cable bending in mind. The dimensions given here are representative values depending on the type of connection cable in use. Therefore, these values are intended for reference only.
- For information on the dimensions when the Box Module and Display Module are attached together, refer to the SP5000 Series Hardware Manual.

CANopen Master Unit

NOTE: The following illustration is of the SP-5600TP.

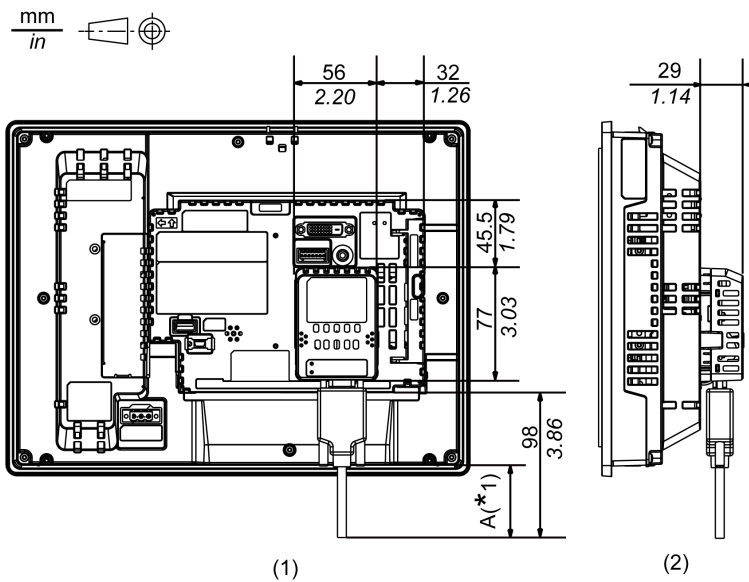

- 1 Rear
- 2 Left

*1 Refer to the following table for the length of A.

Series		Size	Model name	A
SP5000 Series	Premium Display	10 inch	SP-5500TP	62 mm (2.44 in)
		12 inch	SP-5600TP	49 mm (1.93 in)
			SP-5660TP	
		15 inch	SP-5700TP	22 mm (0.87 in)
		15 inch Wide	SP-5700WC	37 mm (1.46 in)
	19 inch Wide	SP-5800WC	3 mm (0.12 in)	
	Advanced Display	7 inch Wide	SP-5400WA	95 mm (3.74 in)
		10 inch Wide	SP-5500WA	70 mm (2.76 in)
12 inch Wide		SP-5600WA	54 mm (2.13 in)	

NOTE:

- All the above values are designed with cable bending in mind. The dimensions given here are representative values depending on the type of connection cable in use. Therefore, these values are intended for reference only.
- For information on the dimensions when the Box Module and Display Module are attached together, refer to the SP5000 Series Hardware Manual.

Chapter 6

Installation and Wiring

What Is in This Chapter?

This chapter contains the following topics:

Topic	Page
Installation	40
Wiring the FLEX NETWORK Connector	42
CANopen cable arrangement	43
Installation Precautions	45

Installation

Installation Procedures

⚠ DANGER

POTENTIAL FOR EXPLOSION

- Verify the power, input, and output (I/O) wiring are in accordance with Class I, Division 2 wiring methods.
- Substitution of any components may impair suitability for Class I, Division 2.
- Do not disconnect equipment while the circuit is live or unless the area is known to be free of ignitable concentrations.
- Remove power before attaching or detaching any connectors to or from this product.
- Ensure that power, communication, and accessory connections do not place excessive stress on the ports. Consider the vibration in the environment when making this determination.
- Securely attach power, communication, and external accessory cables to the panel or cabinet.

Failure to follow these instructions will result in death or serious injury.

Attaching to Box Module

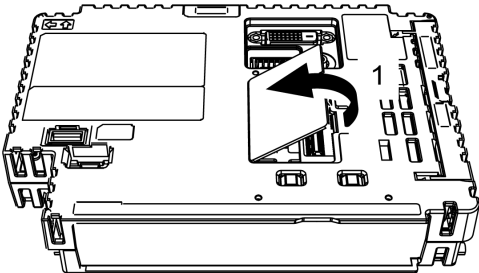
Step	Action
1	<p>At the rear of the Box Module, open the cover in the direction shown by arrow 1 in the figure below.</p> 

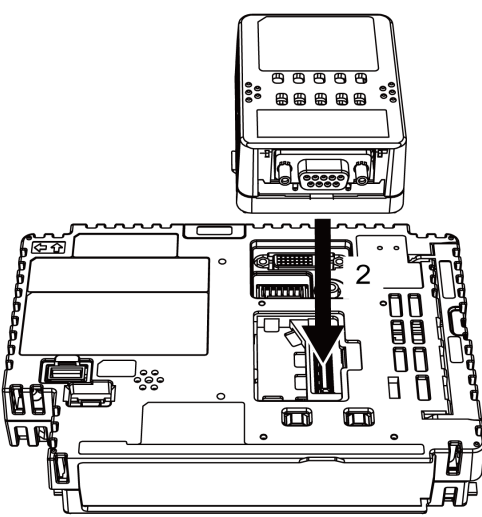
Step	Action
2	<p>As shown by arrow 2, connect the interface at the back of this product to the interface inside the cover.</p> 
3	<p>Continue pressing until you hear a click. Check to make sure this product is fastened securely.</p>

Removing from Box Module

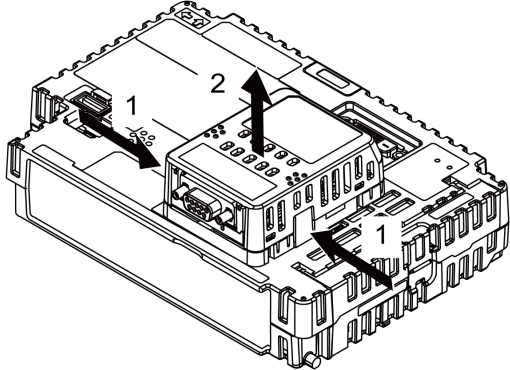
Step	Action
1	<p>Push and hold the hooks at both sides of this product in the direction shown by the arrows 1, then lift the product as shown by arrow 2 to unfasten it.</p> 
2	<p>After removing this product, reattach the cover that you removed during product installation back onto the rear of the Box Module.</p>

Wiring the FLEX NETWORK Connector

Introduction

⚡ ⚠ DANGER

HAZARD OF ELECTRIC SHOCK, EXPLOSION, OR ARC FLASH

- Remove all power before wiring this product.
- Remove the FLEX NETWORK connector from this product prior to wiring.
- Strip wires only to the required length.
- Do not solder the wire itself.

Failure to follow these instructions will result in death or serious injury.

Step	Action
1	Confirm the power cord is not connected to the power supply.
2	Remove the FLEX NETWORK connector from this product.
3	Strip the cable sheath and twist the wire ends. Connect the wire to the connector and tight the screws with a flat-head screwdriver. The necessary torque is 0.25 N•m (2.21 lb-in).
<p>1 Blue (RT+) 2 White (TR-) 3 Shield (SLD)</p>	
4	Insert the wired connector to the FLEX NETWORK Interface of this product.

NOTE:

- Use the Pro-face FLEX NETWORK Connector and FLEX NETWORK Communication Cable (*see page 20*).
- When tightening screws, use a flat-head screwdriver with the following size.
 - Blade thickness: 0.6 mm (0.02 in)
 - Blade width: 2.5 mm (0.10 in)
- Wire should be AWG 28 to AWG 16 thick and twisted.
- Applicable wire sizes are Style 1015 and Style 1007.
- Use copper wire rated for 75 °C (167 °F) or higher.
- If the ends of the individual wires are not twisted correctly, the wires may create a short circuit.
- Be sure to tape or put a plastic tube over the shield line.

CANopen cable arrangement

Introduction

The CANopen interface uses D-sub 9-pin plug connector. The plug is assigned with the CAN_H, CAN_L and CAN_GND connections. CAN_H and CAN_L are two physically different bus levels. CAN_GND is the common reference potential.

⚡ ⚠ DANGER

HAZARD OF ELECTRIC SHOCK, EXPLOSION, OR ARC FLASH

Remove all power before wiring this product.

Failure to follow these instructions will result in death or serious injury.

Diagram

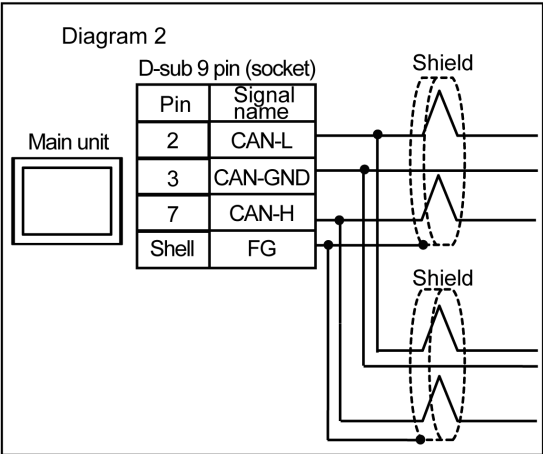
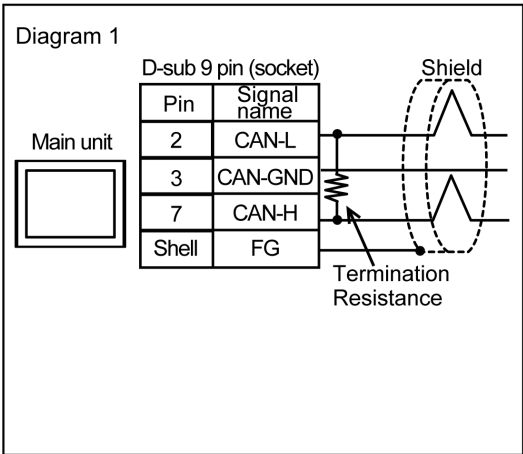
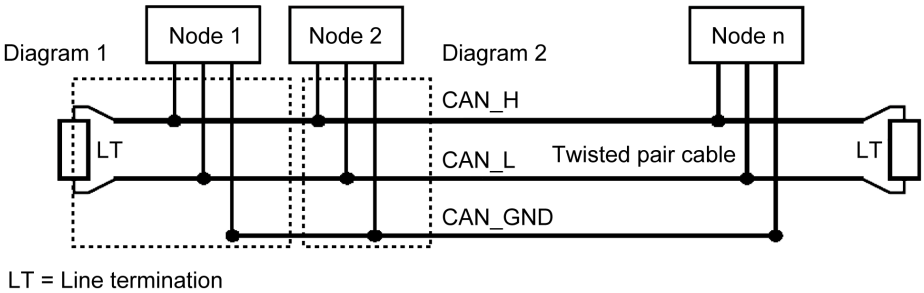

NOTE:

- The cable’s resistance value should be 70 mΩ/m or less.
- To minimize signal reflections from the end of the cable, insert line termination close to the two ends of the bus. Connect both ends of the twisted pair cable (CAN_H and CAN_L) to each LT. Use line termination whose resistance value is 120 Ω. (Resistance Tolerance: 5% maximum, Rated Power: 1/4 W minimum).

Recommended Connector and Cables

Recommended Cable Connector: CiA-recommended CANopen (CiA DR-303-1) -compatible D-Sub 9-pin connector (DIN 41652).

CANopen Recommended Transfer Cable: CiA-recommended CANopen (CiA DR-303-1) - compatible twisted pair cables with shield.

NOTE: If making your own cables or cable connectors, use them at your own risk.

	Model number	Manufacturer	Description
Recommended cable connector	TSXCANKCDF180T	Schneider Electric	Straight connector with terminal selector switch attached
Recommended CANopen cable	TSXCANCA50/ TSXCANCA100	Schneider Electric	Cable for CANopen (IEC 60332-1) 50 m/100 m
	TSXCANCB50/ TSXCANCB100	Schneider Electric	UL-authenticated cable for CANopen (IEC 60332-2) 50 m/100 m

Installation Precautions

Precautions

When installing this product, refer to the following precautions for a proper installation.

In the following, “main unit” is used to refer to both this product and when this product is attached to the SP5000 Series Power Box.

External power failure or failure of the main unit may cause abnormal behavior.

To prevent such abnormal behavior from leading to the abnormal operation of the entire system, and to ensure fail-safe operation, configure circuits that could lead to machine damage or accident due to abnormal operation (such as emergency stop circuit, protection circuit, and interlock circuit) external to the main unit.

The following describes examples of the system circuit design to improve system reliability and to ensure optimum performance.

Rated Voltage

Power for this product is supplied by the SP5000 Series Power Box. Supply power to the Power Box within the specified range.

Power-down status

If there is a voltage interruption on the SP5000 Series Power Box that continues for 1.25 ms or longer for 12 Vdc, or 5 ms or longer for 24 Vdc, the main unit will turn off.

When the SP5000 Series Power Box enters power-down status, the main unit stops calculations even in the middle of an instruction. Design your program with consideration to power-down occurrences.

Emergency Stop Circuit

Do not process emergency stop signals with a software program that inputs signals to the main unit. Configure the emergency stop circuit external to the main unit, as shown in the figure below:

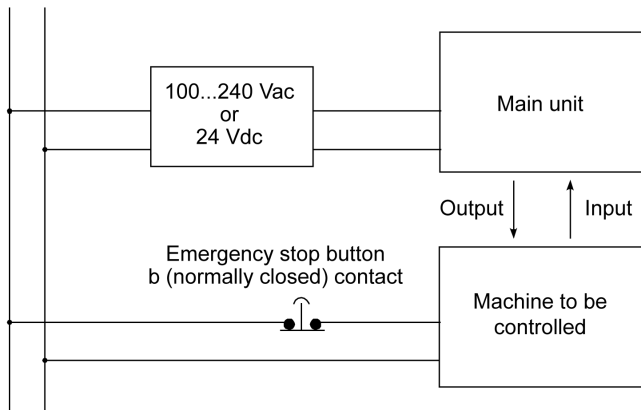

Interlock Circuit 1

To use the main unit or a PLC to control a motor circuit for forward/reverse rotation, configure the interlock circuit shown below external to the main unit.

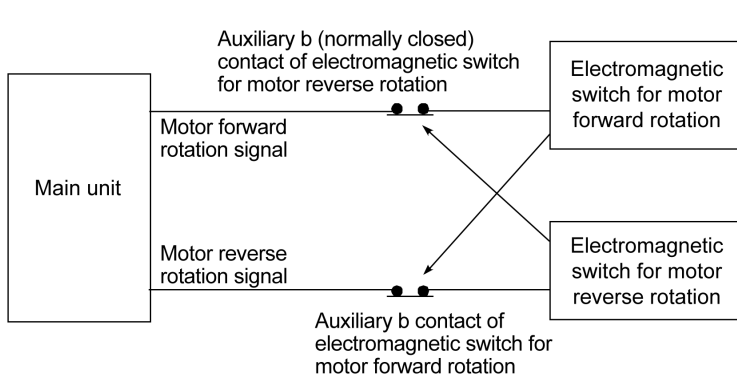

NOTE: After executing an internal program, the main unit outputs ON/OFF information to the output devices at the same time. For example, the electromagnetic switches for forward and reverse rotation of a motor are turned on and off at the same time. Consequently, a situation may arise in which both of the main contacts of the motor circuits for the electromagnetic switches for forward and reverse rotation turn on, causing a short-circuit of the R and T phases. To avoid this situation, you need to provide the interlock circuit shown above or use an electromagnetic switch equipped with a mechanical interlock for a forward/reverse circuit.

Interlock Circuit 2

If there is a possibility that abnormal operation of the main unit could lead to an accident, design a fail-safe measure that uses external hardware devices for an interlock circuit.

For a system that requires the running motor to stop before all other processes when the travel limit switch is activated, send the signals from the travel limit switch to the input terminals of the main unit, and never design the system to use software for this process.

Configure a circuit with hardware to reliably stop the running motor, as shown below.

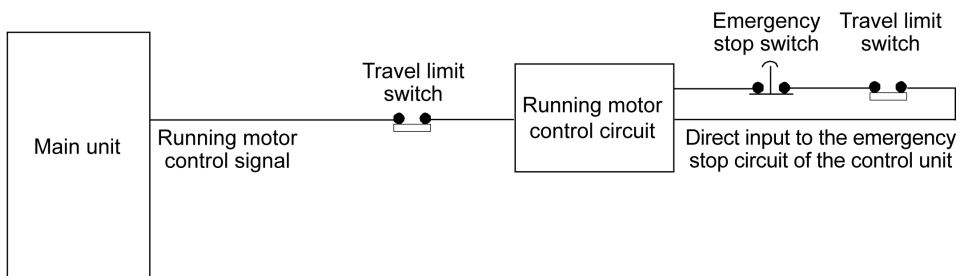

Chapter 7

After-sales Service

After-sales Service

Information

For details on after-sales service, refer to our website at

<http://www.pro-face.com/trans/en/manual/1001.html>

