

STM6000 Series



STM-6400WA
Model: PFXSTM6400WAD
Model: PFXSTM6400WADE



STM-6200WA
Model: PFXSTM6200WAD
Model: PFXSTM6200WADE

Model Number Configuration

Display Module

PFXSTM6 $\frac{*}{(1)}$ $\frac{*}{(2)}$ $\frac{*}{(3)}$ $\frac{*}{(4)}$ $\frac{*}{(5)}$ $\frac{D}{(5)}$ *

(1) Size		(2) Type		(3) Resolution		(4) Touch Panel		(5) (5) Power Supply / available software	
4	7"	00	Reserved	W	Wide TFT	A	Analog	D	DC / BLUE
2	4"							DE	DC / GP-Pro EX

Display Specifications

	STM-6400WA	STM-6200WA
Model No.	PFXSTM6400WAD (BLUE) PFXSTM6400WADE (GP-Pro EX)	PFXSTM6200WAD (BLUE) PFXSTM6200WADE (GP-Pro EX)
Display Type	TFT Color LCD	
Display Size	7.0" wide	4.3" wide
Resolution	800 x 480 pixels (WVGA)	480 x 272 pixels
Effective Display Area	154.08 x 85.92 mm (6.07 x 3.38 in)	95.04 x 53.86 mm (3.74 x 2.12 in)
Display Colors	16 million colors For details about display colors, refer to the manual of your screen editing software.	
Backlight	White LED (Not user replaceable. When replacement is required, contact customer support.)	
Backlight Service Life	50,000 hours or more (continuous operation at 25 °C [77 °F] before backlight brightness decreases to 25%)	
Brightness Control	16 levels (Adjusted with touch panel or software)	
Touch Panel Type	Resistive film (analog, single touch)	
Touch Panel Resolution	1,024 x 1,024	
Touch Panel lifetime	1,000,000 times or more	

Electrical Specifications (Rear module)

	STM-6400WA	STM-6200WA
Model No.	PFXSTM6400WAD (BLUE) PFXSTM6400WADE (GP-Pro EX)	PFXSTM6200WAD (BLUE) PFXSTM6200WADE (GP-Pro EX)
Rated Input Voltage	24 Vdc	
Input Voltage Limits	19.2...28.8 Vdc	
Voltage Drop	5 ms or less	
Power Consumption	Max	6.8 W
	When power is not supplied to external devices	3.5 W
In-rush current	30 A or less	
Noise immunity	Noise voltage: 1,000 Vp-p Pulse duration: 1 µs Rise time: 1 ns (via noise simulator)	
Voltage Endurance	1,000 Vac for 1 minute (between power terminal and FG terminal)	
Insulation Resistance	500 Vdc, 10 MΩ or more (between power terminal and FG terminals)	

Electrical Specifications (Display module)

	STM-6400WA	STM-6200WA
Model	PFXSTM6400WAD (BLUE) PFXSTM6400WADE (GP-Pro EX)	PFXSTM6200WAD (BLUE) PFXSTM6200WADE (GP-Pro EX)
Power Consumption	Max	3.6 W
	When power is not supplied to external devices	1.3 W
		1.0 W
		0.6 W

NOTE:

The power consumption for the combined unit of the rear module and the display module equals the sum of power consumption of the two modules.

■ Environmental Specification

	STM-6400WA	STM-6200WA
Model No.	PFXSTM6400WAD (BLUE) PFXSTM6400WADE (GP-Pro EX)	PFXSTM6200WAD (BLUE) PFXSTM6200WADE (GP-Pro EX)
Ambient air temperature	0 to 50 °C (32 to 122 °F)	
Storage Temperature	-20 to 60 °C (-4 to 140 °F)	
Ambient air and storage humidity	10%...90% RH (Non condensing, wet bulb temperature 39 °C [102.2 °F] or less)	
Dust	0.1 mg/m ³ (10-7 oz/ft ³) or less (non-conductive levels)	
Pollution Degree	For use in Pollution Degree 2 environment	
Corrosive Gases	Free of corrosive gases	
Air pressure (altitude range)	800 to 1,114 hPa (2,000 m [6,561 ft.] above sea level or less)	
Vibration Resistance	IEC/EN 61131-2 compliant 5 to 9 Hz single amplitude 3.5 mm [0.14 in.] 9 to 150 Hz fixed acceleration: 9.8 m/s ² X, Y, Z directions for 10 cycles (approx. 100 min.)	
Shock Resistance	IEC/EN 61131-2 compliant 147 m/s ² , X, Y, Z directions for 3 times	
Electrical fast transient/burst	IEC 61000-4-4 2 kV: Power port (display unit) 1 kV: Signal ports	
Electrostatic Discharge Immunity	Contact Discharge Method: 6 kV Air Discharge Method: 8 kV (IEC/EN61000-4-2 Level 3)	

■ Interface Specification

	STM-6400WA	STM-6200WA
Model No.	PFXSTM6400WAD (BLUE) PFXSTM6400WADE (GP-Pro EX)	PFXSTM6200WAD (BLUE) PFXSTM6200WADE (GP-Pro EX)
Serial (COM1)	Asynchronous Transmission: RS-232C/422/485, Data Length: 7 or 8 bits, Stop Bit: 1 or 2 bits, Parity: None, Even or Odd, Data Transmission Speed: 2,400 to 115,200 bps, Connector: D-Sub 9 (plug)	
USB (Type A)	Conforms to USB 2.0 (Type A) x 1 Power supply voltage: 5 Vdc ±5 % Output Current: 500 mA/port Maximum transmission distance : 5 m [16.4 ft.]	
USB (micro-B)	Conforms to USB 2.0 (micro-B) x 1, Maximum transmission distance : 5 m [16.4 ft.]	
Ethernet	IEEE802.3i/IEEE802.3u, 10BASE-T/100BASE-TX, Connector: Modular jack (RJ-45) x 2	

■ Structural Specification (Rear Module)

	STM-6400WA	STM-6200WA
Model No.	PFXSTM6400WAD (BLUE) PFXSTM6400WADE (GP-Pro EX)	PFXSTM6200WAD (BLUE) PFXSTM6200WADE (GP-Pro EX)
Grounding	Functional grounding: Grounding resistance of 100 Ω or less, 2 mm ² (AWG 14) or thicker wire, or your country's applicable standard (SG and FG are connected inside the product).	
Cooling method	Natural air circulation	
Structure	IP20	
External dimensions (W x H x D)	145.6 x 108.23 x 41.4 mm (5.73 x 4.26 x 1.63 in) (excluding protrusions)	
Weight	0.27 kg (0.6 lb) or less	

NOTE: EQUIPMENT DAMAGE

- Store this product in areas where temperatures are within the product's specifications.
 - Do not restrict or block the product's ventilation slots.
- Failure to follow these instructions can result in equipment damage.

■ Structural Specification (Display Module)

	STM-6400WA	STM-6200WA
Model No.	PFXSTM6400WAD (BLUE) PFXSTM6400WADE (GP-Pro EX)	PFXSTM6200WAD (BLUE) PFXSTM6200WADE (GP-Pro EX)
Cooling method	Natural air circulation	
Structure *1	IP65F, UL 50/50E, Type 1, Type 4X (indoor use only), Type 12, Type 13	
External dimensions (W x H x D)	201.2 x 137.2 x 17.1 mm (7.92 x 5.4 x 0.67 in) (excluding protrusions)	140.4 x 101.1 x 13.9 mm (5.53 x 3.98 x 0.55 in) (excluding protrusions)
Panel cut dimensions	Diameter 22.5 mm (0.88 in)	
Weight	0.49 kg (1.08 lb) or less	0.22 kg (0.49 lb) or less

*1 The front face of this product, installed in a solid panel, has been tested using conditions equivalent to the standards shown in the specification. Even though this product's level of resistance is equivalent to these standards, oils that should have no effect on this product can possibly harm this product. This can occur in areas where either vaporized oils are present, or where low viscosity cutting oils are allowed to adhere to this product for long periods of time. If this product's front face protection sheet peels off, these conditions can lead to the ingress of oil into this product and separate protection measures are suggested. Also, if nonapproved oils are present, they may cause deformation or corrosion of the front panel's cover. Therefore, prior to installing this product, be sure to confirm the type of conditions that will be present in this product's operating environment. If the installation gasket is used for a long period of time, or if this product and its gasket are removed from the panel, the original level of protection cannot be kept. To maintain the original

■ Memory (Editor : BLUE)

		STM-6400WA	STM-6200WA
Model No.		PFXSTM6400WAD	PFXSTM6200WAD
Application Memory	Editor : BLUE	FLASH EPROM	
		128MB	
	Removable system	-	
Backup Memory	Editor : BLUE	NVRAM 500KB	
	Battery	Unreplaceable battery by the customer/ Primary battery for clock data backup	

■ Memory (Editor : GP-Pro EX)

		STM-6400WA	STM-6200WA
Model No.		PFXSTM6400WADE	PFXSTM6200WADE
Application memory	Editor : GP-Pro EX	Media	FLASH EPROM
		Screen area*1	64 MB
		User font area	8 MB
		Logic program area	132KB (Equivalent to 15,000 steps)
		Free space	-
	Removable system	No	
Backup memory	Editor : GP-Pro EX	Screen area	SRAM 320 KB
		Variable area	SRAM 64 KB
	Battery	Unreplaceable battery by the customer/ Primary battery for clock data backup	

*1 Use the screen area when the user font area's capacity is exceeded – for example, when an image font or a picture font is used –.

■ Panel Cut Dimensions

Based on the panel cut dimensions, open a mount hole on the panel.

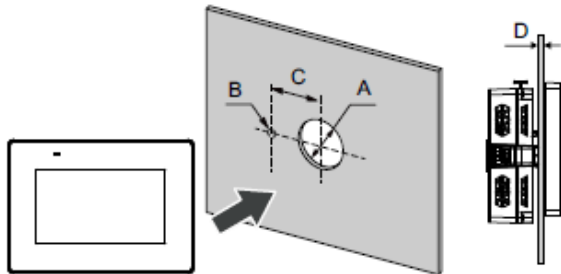

A	B	C
22.5 mm (+0/-0.3 mm) (0.88 in [+0/-0.01 in])	4.0 mm (+0/-0.2 mm) (0.15 in [+0/-0.007 in])	30.0 mm (+0/-0.2 mm) (1.18 in [+0/-0.007 in])

Panel thickness recommended range:

Panel material	Thickness range (D)
Steel	1.5... 6.0 mm (0.06... 0.23 in)
Glass fiber reinforced plastics (minimum GF30)	3.0... 6.0 mm (0.12... 0.23 in)

■ Parts Identification

Parts Identification (Display Module)

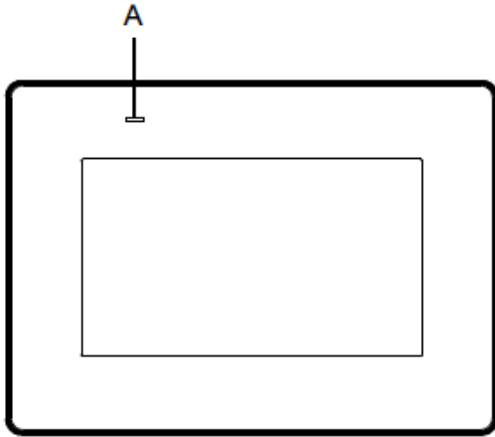

Front

A. Status LED

Parts Identification (Rear Module)

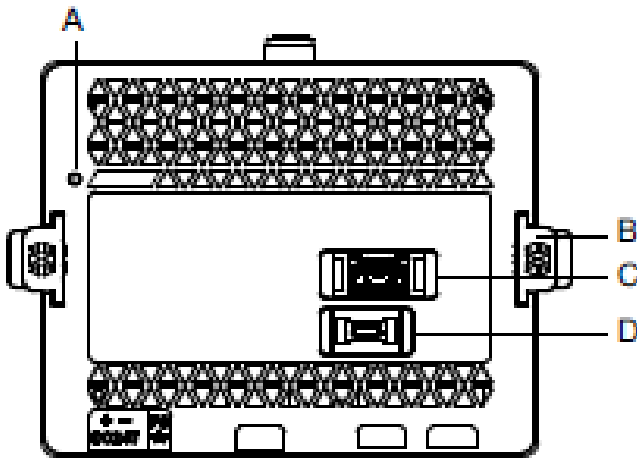

Front

- A. Status LED
- B. Bumper
- C. USB (Type A) interface
- D. USB (micro-B) interface
- E. Power plug connector
- F. Serial interface (COM1)
- G. Ethernet interface (ETH1)
- H. Ethernet interface (ETH2)

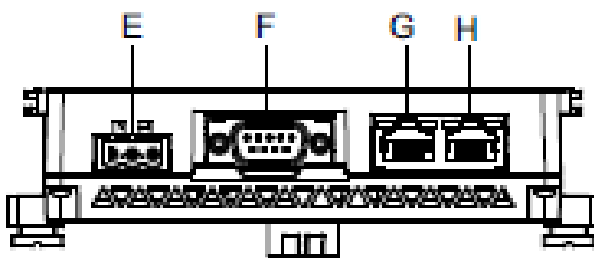

Bottom

■ Display Module Dimensions

STM-6200WA

Display Module Dimensions

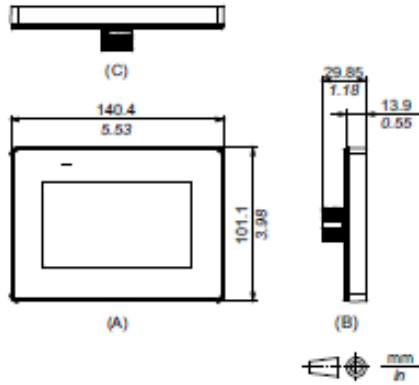

- A. Front
- B. Left
- C. Bottom

Dimensions When Rear Module Attached to Display Module

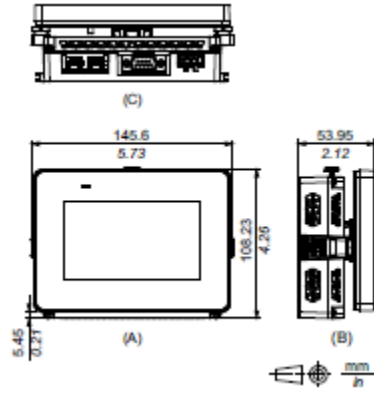

STM-6400WA

Display Module Dimensions

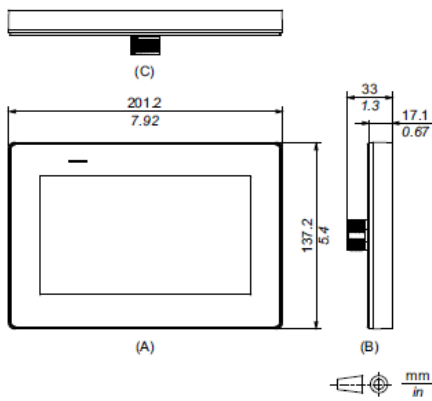

- A. Front
- B. Left
- C. Bottom

Dimensions When Rear Module Attached to Display Module

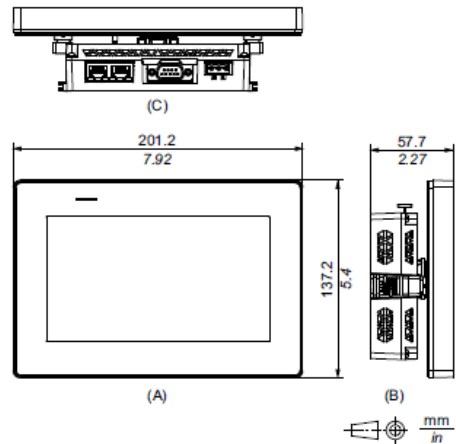

■ Rear Module Dimensions

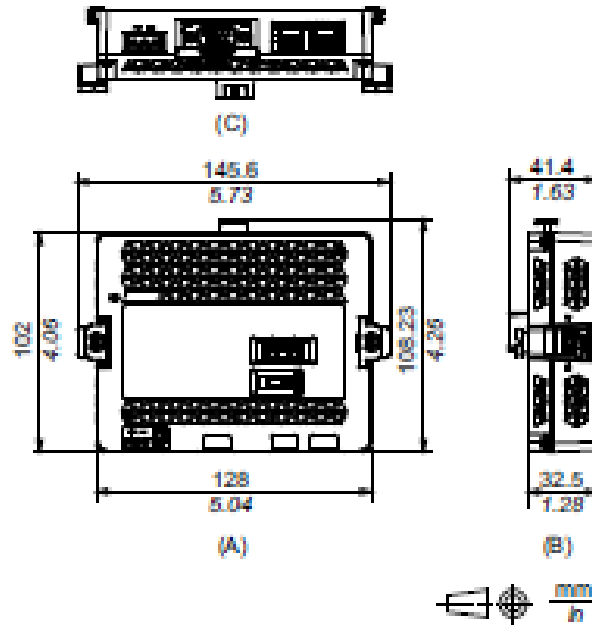

- A. Front
- B. Right
- C. Bottom

Dimensions When Rear Module Attached to Installation Adapter

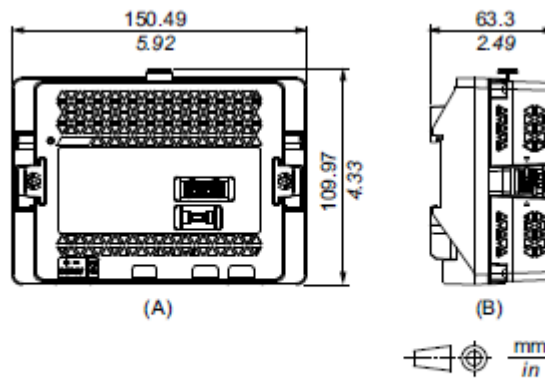

- A. Front
- B. Right