

LT-3300T (Model No.: PFXLT3300TADC)

Functional Specifications		
Display Type	TFT Color LCD	
Display Size	5.7"	
Resolution	320 x 240 pixels (QVGA)	
Dot pitch	W0.36 x H0.36 mm [W0.01 x H0.01 in.]	
Effective Display Area	W115.2 x H86.4 mm [W4.54 x H3.40 in.]	
Display Colors	65,536 Colors (No blink)/16,384 Colors (Blink)	
Backlight	White LED (User nonreplaceable parts. Factory replacement required.)	
Brightness Control	8 Levels (Adjusted with the touch panel)	
Contrast Control	-	
Backlight Service Life	50,000 hrs. or more (continuous operation at 25°C before backlight brightness decreases to 50%)	
Language Fonts	Japanese: 6,962 (JIS Standards 1 & 2) (including 607 non-kanji characters), ANK: 158 (Korean fonts, Simplified Chinese and Traditional Chinese fonts are downloadable.	
Character Sizes	Standard font: 8 x 8, 8 x 16, 16 x 16 and 32 x 32 pixel fonts, Stroke font: 6 to 127 pixel fonts, Image font: 8 to 72 pixel fonts	
Font Sizes *1	Standard font: Width can be expanded up to 8 times. Height can be expanded up to 8 times.	
Text	8 x 8 dots	40 char. x 30 rows
	8 x 16 dots	40 char. x 15 rows
	16 x 16 dots	20 char. x 15 rows
	32 x 32 dots	10 char. x 7 rows
Control Memory	Variable Area	SRAM 64 KB (uses lithium battery)
	Program Area	FLASH EPROM 132 KB
	Number of Step *2	Equivalent to 15,000 steps
Application Memory *3	FLASH EPROM 6 MB	
Data Backup	SRAM 128 KB (Lithium battery for backup memory)	
Clock Accuracy *4	±65 sec/month (deviation at room temperature and power is OFF)	
Touch Panel Type	Resistive Film (analog)	
Touch Panel Resolution	1,024 x 1,024	
Touch Panel Service Life	1,000,000 times or more	
Interface	Serial (COM1)	RS-232C/422/485, Asynchronous Transmission, Data Length: 7 or 8 bit, Parity: none, Even or Odd, Stop Bit: 1 or 2 bit, Data Transmission Speed: 2,400 bps to 115.2 kbps, Connector: D-Sub9 (plug)
	Ethernet (LAN)	IEEE802.3i/IEEE802.3u, 10BASE-T/100BASE-TX, Connector: Modular jack (RJ-45) x 1
	USB (Type-A)	Conforms to USB1.1 (TYPE-A) x 1, Power Supply Voltage: DC 5 V ±5 %, Output Current: 500 mA or less, Communication Distance: 5 m or less
	AUX/Expansion Unit *5	Interface for external additional unit only (such as communication equipment) (external)
	EX Module Interface *5	Interface for Pro-face's EX Modules. Up to three EX modules can be connected
	Control (DIO Source Type)	16-Point Input Sink Source, 16-Point Output Source, Connector: 38pin

*1: Other font sizes can be set up with the Editor software.

*2: Up to 60,000 steps can be converted in software. However, this reduces application memory capacity (for screen data) by 1 MB.

*3: Capacity available for user application.

*4: Depending on the operating temperature and age of unit, the clock can deviate from -380 to +90 sec/month. For systems where this level of deviation is a problem, the user should monitor and make adjustments when required.

*5: EX Module and Communication Expansion Unit cannot be used at the same time.

General Specifications	
Supported Standards and Regulations	
Rated Input Voltage	DC 24 V
Input Voltage Limits	DC 19.2 to 28.8 V
Allowable Voltage Drop	3 ms or less
Power Consumption	27 W or less
In-Rush Current	30 A or less
Voltage Endurance	AC 1,000 V, 20 mA for 1 min (between charging and FG terminals)
Insulation Resistance	DC 500 V, 10 MΩ or more (between charging and FG terminals)
Surrounding Air Temperature	0 to 50 °C
Storage Temperature	-20 to +60 °C
Ambient Humidity	10 to 90 % RH (Wet bulb temperature: 39 °C or less - no condensation.)
Storage Humidity	
Dust	0.1 mg/m ³ or less (non-conductive levels)
Pollution Degree	For use in Pollution Degree 2 environment
Atmosphere	Free of corrosive gases
Air Pressure (altitude range)	800 to 1,114 hPa (2,000 m above sea level or less)
Vibration Resistance	IEC/EN61131-2 compliant, 5 to 9 Hz Single amplitude 3.5 mm [0.14 in.], 9 to 150 Hz Fixed acceleration: 9.8 m/s ² , X, Y, Z directions for 10 cycles (100 min)
Concussion Resistance	IEC/EN61131-2 compliant, 147 m/s ² , X, Y, Z directions for 3 times
Noise Immunity	Noise Voltage: 1,000 Vp-p, Pulse Duration: 1 μs, Rise Time: 1 ns, (via noise simulator)
Electrostatic Discharge Immunity	Contact Discharge Method: 6kV (IEC/EN61000-4-2 Level 3)
Grounding	Functional grounding: Grounding resistance of 100Ω, 2mm ² or thicker wire, or your country's applicable standard. (Same for FG and SG terminals)
Structure *6	Equivalent to IP65f NEMA #250 TYPE 4X/13 (on the front panel when properly installed in an enclosure)
Installation Configuration	Embedded panel
Cooling Method	Natural air circulation
Weight Approx.	1 kg [2.2 lb] or less (display unit only)
External Dimensions	W167.5 x H135 x D78 mm [W6.59 x H5.31 x D2.87 in.]
Panel Cut Dimensions *7	W156 x H123.5 mm [W6.14 x H4.86 in.], Panel thickness area: 1.6 to 5 mm [0.06 to 0.2 in.]

*6 The front face of the GP unit, installed in a solid panel, has been tested using conditions equivalent to the standards shown in the specification. Even though the GP unit's level of resistance is equivalent to these standards, oils that should have no effect on the GP can possibly harm the unit. This can occur in areas where either vaporized oils are present, or where low viscosity cutting oils are allowed to adhere to the unit for long periods of time. If the GP's front face protection sheet becomes peeled off, these conditions can lead to the ingress of oil into the GP and separate protection measures are suggested. Also, if non-approved oils are present, it may cause deformation or corrosion of the front panel's plastic cover. Therefore, prior to installing the GP unit, be sure to confirm the type of conditions that will be present in the GP's operating environment. If the installation gasket is used for a long period of time, or if the unit and its gasket are removed from the panel, the original level of the protection cannot be guaranteed. To maintain the original protection level, be sure to replace the installation gasket regularly.

*7 Regarding dimensional tolerance, everything +1/-0 mm [+0.04/-0 in.] and R in angle are below R3 [R0.12 in.].

External Dimensions / Interfaces *1

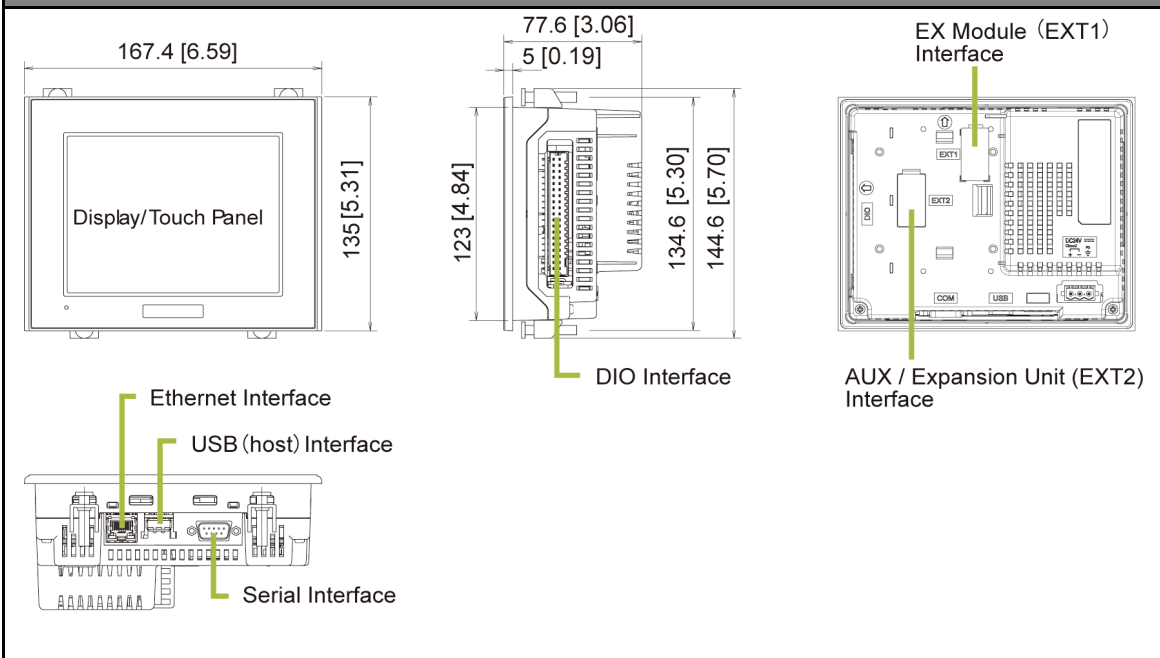

Cable Attached Dimensions *2

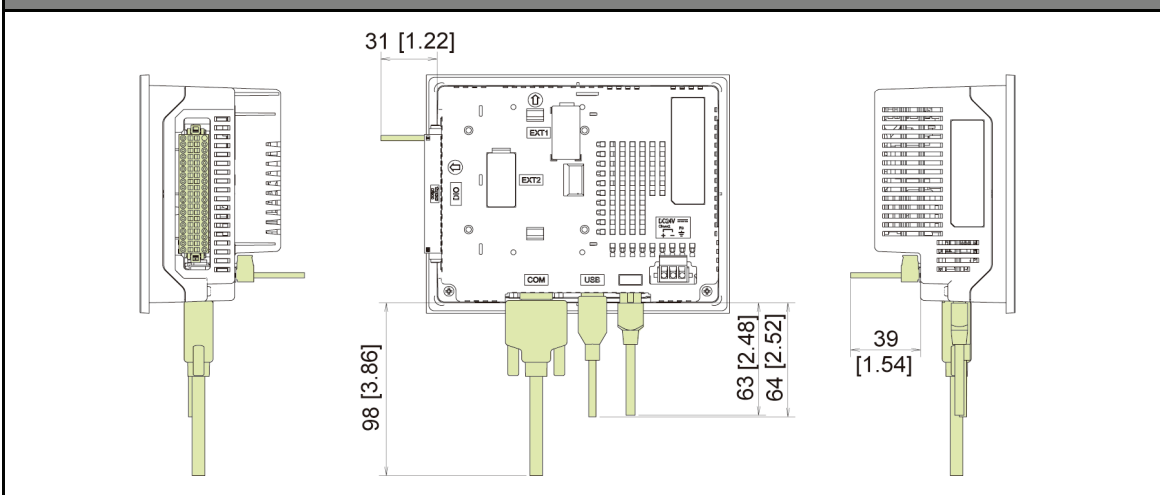

Panel Cut-Out

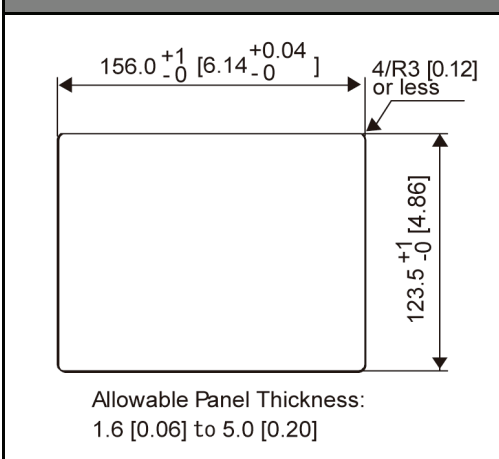

*1 The maximum thickness when three EX modules are connected: 123.0mm [4.84in.].

*2 Depending on type of connection cable used the dimensions shown above will change. The dimensions given here are representative values and are intended for reference only.

Input Specifications	
Rated Voltage	DC24V
Maximum Allowable	DC28.8V
Input Method	Sink / Source Input
Rated Current	6.5mA (DC24V) (IN0, IN2, IN4, IN6) 4.1mA (DC24V) (Other inputs)
Input Resistance	Approx. 3.7kΩ (IN0, IN2, IN4, IN6) Approx. 5.9kΩ (Other inputs)
Input Points	16
Common Lines	1
Common Design	16 points / 1 common line
Operation	ON Voltage DC19V or more
Range	OFF Voltage DC5V or less
Input Delay	OFF to ON 0.5 to 20ms *1
Time	ON to OFF 0.5 to 20ms *1
Input Signal Display	No LED indicators
Isolation Method	Photocoupler Isolation
External Connection	38-pin connector (used with Output section)
External Power Supply	For Signal: DC24V

Output Specifications	
	OUT0 to OUT3 OUT4 to OUT15
Rated Voltage	DC24V
Allowable Voltage	DC20.4V to 28.8V
Output Method	Source Output
Maximum Load Voltage	200mA / 1 Point 1.6A / 1 common
Minimum Load Current	1mA 1mA (Pulse/PWM Output Unavailable)
Output Voltage Drop	DC0.5V or less
Output Delay Time	OFF to ON 5 μs or less (with output DC24V, 200mA) 0.5ms or less (with output DC24V, 200mA) ON to OFF 5 μs or less (with output DC24V, 200mA) 0.5ms or less (with output DC24V, 200mA)
Voltage Leakage (When OFF)	0.1mA or less
Clamp Voltage	39V ± 1
Type of Output	Transistor Output
Common Lines	2
Common Design	8 points / 1 common line x 2
External Connection	38-pin connector (used with input section)
Output Protection Type	Output is unprotected
Internal Fuse	3.5A, 125V Chip fuse x 2 (not replaceable)
Surge Control Circuit	Zener diode
Output Points	16
Output Signal Display	No LED indicators
Isolation Method	Photocoupler Isolation
External Power Supply	For Signal: DC24V

Pulse/PWM Output Specifications	
	Pulse PWM
Output Points	4 points
Output Method	PLS0 to PLS3 (OUT0 to OUT3) User Defined PWM0 to PWM3 (OUT0 to OUT3) User Defined
Load Voltage	DC24V
Minimum Load Current	1mA
Minimum Load Current	Max.65kHz (set through software) Varies depending on the number of CH of High-speed counter, pulse output
Pulse Acceleration	Available Not Available
ON Duty	50% ± 10% (at 65kHz) *2 19 to 81% (at 65kHz) *3

High-speed Counter / Pulse Catch Input Specifications			
	High-speed Counter (with Synchronize Output)		Pulse Catch
Input	DC24V Open Collector		DC24V Open Collector
	Single phase (4 points)	Double phase (1 or 2 points)	
Input Points	CT0 (IN0), CT1 (IN2), CT2 (IN4), CT3 (IN6), User Defined	Use CT0 (IN0), CT1 (IN2) in pairs. CT0: Phase A, CT1: Phase B, CT2 (IN4), CT3 (IN6) in pairs. CT2: Phase A, CT3: Phase B User Defined	IN0, IN2, IN4, IN6, User Defined
Synchronize Output	CT0 (OUT0) CT1 (OUT1) CT2 (OUT2) CT3 (OUT3)	CT0 CT1 (OUT1) CT2 CT3 (OUT2)	-
Minimum Pulse Width (Pulse Input)			Input signal ON width 5µs or more
Count Speed (Rise, Fall Time)	 t = 1µs or less (100Kpps)		-
Phase	1 Phase	90 degree phase differential 2-phase signal / 1-phase +directional signal	-
High Speed Count	100Kpps	50Kpps	-
Count Edge Designation	Available	Not Available	-
Count Register	32-bit UP / DOWN Counter		-
Counter Mode Change	Set through software		-
Upper/Lower Limit	Not Available		-
Preload/Prestrobe	Available		-
Marker Input (Clear Counter Value)	-	IN3, IN7	-

Pin Connection	Pin No.	Signal Name	Pin No.	Signal Name
	A1	IN1	B1	IN0 (CT0)
	A2	IN3	B2	IN2 (CT1)
	A3	IN5	B3	IN4 (CT2)
	A4	IN7	B4	IN6 (CT3)
	A5	IN9	B5	IN8
	A6	IN11	B6	IN10
	A7	IN13	B7	IN12
	A8	IN15	B8	IN14
	A9	NC	B9	COM
	A10	+24V	B10	+24V
	A11	NC	B11	0V
	A12	OUT1 (PLS1, PWM1)	B12	OUT0 (PLS0, PWM0)
	A13	OUT3 (PLS3, PWM3)	B13	OUT2 (PLS2, PWM2)
	A14	OUT5	B14	OUT4
	A15	OUT7	B15	OUT6
	A16	OUT9	B16	OUT8
	A17	OUT11	B17	OUT10
	A18	OUT13	B18	OUT12
	A19	OUT15	B19	OUT14

*1: Digital filter can be set intervals of 0.5ms.
 *2: The ON duty error (10%) reduces as the output frequency setting is lower.
 *3: ON duty (effective range) increases as the output frequency setting is lower.

Input Circuit

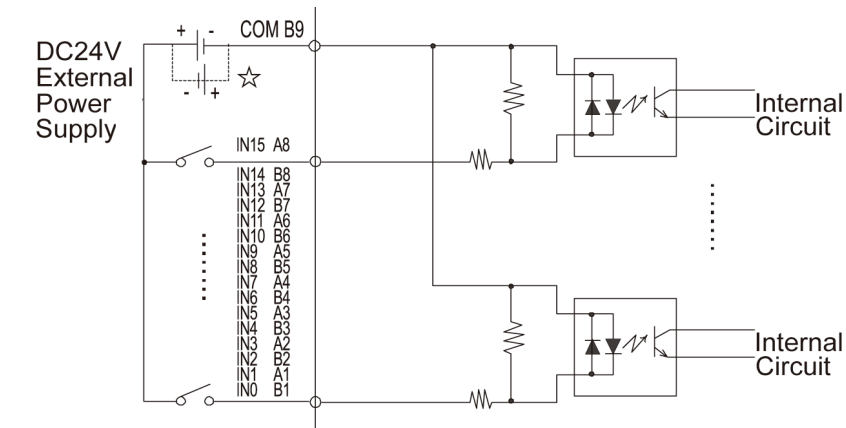

☆ Dotted area indicates the cable diagram with sink output type devices.

Output Circuit

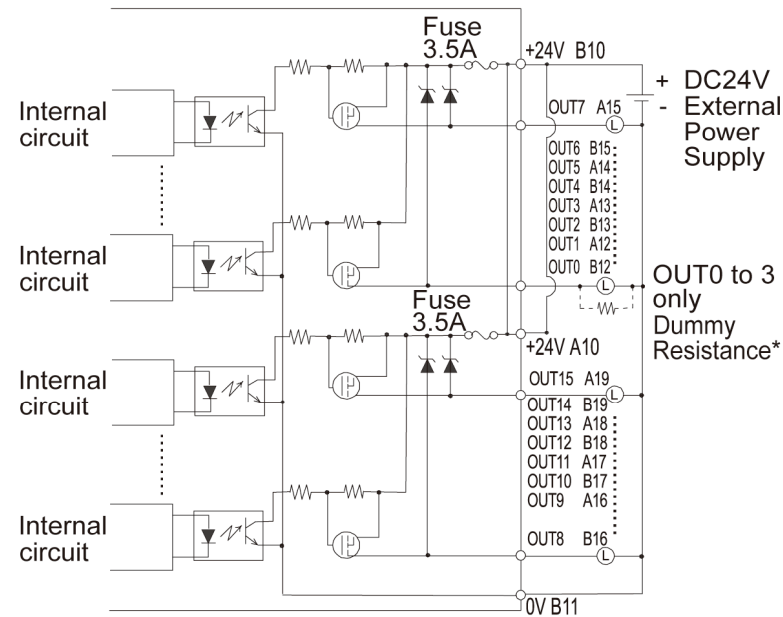

* For faster response with light load use an external dummy resistance.

Pro-face's LT3000 Series website <http://www.pro-face.com/product/hmi/lt3000.html>