

ConneXium

TCSESM Managed Switch Installation Manual

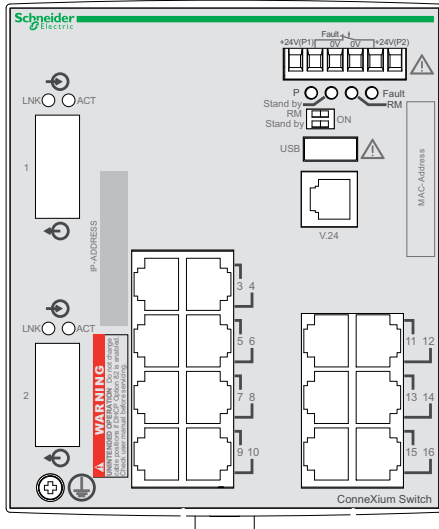

TCSESM163F2CU0/CS0

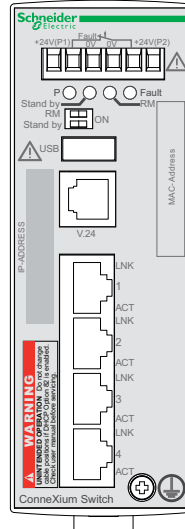

TCSESM043F23F0

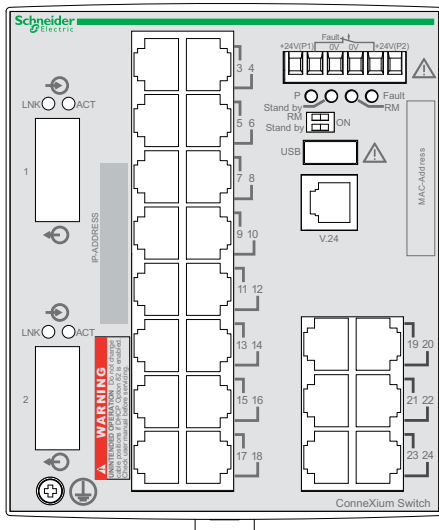

TCSESM243F2CU0

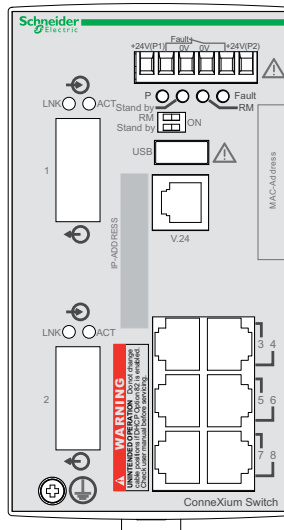

TCSESM083F2CU0/CS0/CX0

Contents

About this Manual	3
Key	5
Safety instructions	5
1 Device description	12
1.1 General device description	12
1.2 Device versions	14
1.2.1 Device versions	14
1.2.2 Examples of switch versions	15
2 Assembly and start-up	19
2.1 Safety instructions	19
2.2 Installing the device	20
2.2.1 Overview of installation	20
2.2.2 Unpacking and checking	20
2.2.3 Installing the SFP modules (optional)	21
2.2.4 Insert data in label area	21
2.2.5 Adjust DIP switch settings	22
2.2.6 Supply voltage and signal contact	22
2.2.7 Installing the device on the DIN rail, grounding	24
2.2.8 Dimension drawings	25
2.2.9 Installing the terminal block, start-up procedure	26
2.2.10 Connecting the data lines	26
2.3 Display elements	29
2.4 Basic set-up	30
2.5 Maintenance	33
2.6 Disassembly	33
3 Technical data	34

About this Manual

Validity Note

The data and illustrations found in this book are not binding. We reserve the right to modify our products in line with our policy of continuous product development. The information in this document is subject to change without notice and should not be construed as a commitment by Schneider Electric.

Product Related Information

Schneider Electric assumes no responsibility for any errors that may appear in this document. If you have any suggestions for improvements or amendments or have found errors in this publication, please notify us.

No part of this document may be reproduced in any form or by any means, electronic or mechanical, including photocopying, without express written permission of Schneider Electric.

All pertinent state, regional, and local safety regulations must be observed when installing and using this product. For reasons of safety and to ensure compliance with documented system data, only the manufacturer should perform repairs to components.

When devices are used for applications with technical safety requirements, please follow the relevant instructions.

Failure to use Schneider Electric software or approved software with our hardware products may result in improper operating results.

Failure to observe this product related warning can result in injury or equipment damage.

User Comments

We welcome your comments about this document. You can reach us by e-mail at techpub@schneider-electric.com

Related Documents

Title	Reference Number
ConneXium TCSESM, TCSESM-E Managed Switch Redundancy Configuration User Manual	31007126
ConneXium TCSESM, TCSESM-E Managed Switch Basic Configuration User Manual	31007122
ConneXium TCSESM, TCSESM-E Managed Switch Command Line Interface Reference Manual	31007130
ConneXium TCSESM, TCSESM-E Managed Switch Web-based Interface Reference Manual	EIO0000000482
ConneXium TCSESM Managed Switch Installation Manual	31007118
ConneXium TCSESM-E Extended Managed Switch Installation Manual	EIO0000000529

Note: The Glossary is located in the Reference Manual “Command Line Interface”.

The “Web-based Interface” reference manual contains detailed information on using the Web interface to operate the individual functions of the device.

The “Command Line Interface” reference manual contains detailed information on using the Command Line Interface to operate the individual functions of the device.

The “Installation” user manual contains a device description, safety instructions, a description of the display, and the other information that you need to install the device.

The “Basic Configuration” user manual contains the information you need to start operating the device. It takes you step by step from the first startup operation through to the basic settings for operation in your environment.

The “Redundancy Configuration” user manual contains the information you need to select a suitable redundancy procedure and configure that procedure.

Key

The symbols used in this manual have the following meanings:

▶	Listing
□	Work step
■	Subheading

Safety instructions

■ Important Information

Notice: Read these instructions carefully, and look at the equipment to become familiar with the device before trying to install, operate, or maintain it. The following special messages may appear throughout this documentation or on the equipment to warn of potential hazards or to call attention to information that clarifies or simplifies a procedure.



The addition of this symbol to a Danger or Warning safety label indicates that an electrical hazard exists, which will result in personal injury if the instructions are not followed.



This is the safety alert symbol. It is used to alert you to potential personal injury hazards. Obey all safety messages that follow this symbol to avoid possible injury or death.



DANGER

DANGER indicates an imminently hazardous situation which, if not avoided, **will result in** death or serious injury.



WARNING

WARNING indicates a potentially hazardous situation which, if not avoided, **can result in** death or serious injury.



CAUTION

CAUTION indicates a potentially hazardous situation which, if not avoided, **can result in** minor or moderate injury.

PLEASE NOTE: Electrical equipment should be installed, operated, serviced, and maintained only by qualified personnel. No responsibility is assumed by Schneider Electric for any consequences arising out of the use of this material.
© 2012 Schneider Electric. All Rights Reserved.

■ Usage

The device may only be employed for the purposes described in the catalog, technical description, and manuals.

■ Supply voltage

For safety reasons the devices have been designed to operate at low voltages. Thus, they may only be connected to the supply voltage connections and to the signal contact with SELV circuits with the voltage restrictions in accordance with IEC/EN 60950-1.

Relevant for North America:

The device may only be connected to a supply voltage of class 2 that fulfills the requirements of the National Electrical Code, Table 11(b). If the voltage is being supplied redundantly (two different voltage sources), the combined supply voltages must fulfill the requirements of the National Electrical Code, Table 11(b).

Relevant for North America: For use in class 2 circuits.

Use 60/75 °C (140/167 °F) or 75 °C (167 °F) copper (Cu) wire only.

Relevant for North America

for devices certified for hazardous locations:

Power, input and output (I/O) wiring must be in accordance with Class 1, Division 2 wiring methods [Article 501-4(b) of the National Electrical Code, NFPA 70] and in accordance with the authority having jurisdiction.

The device does not contain any service components. If the device is not functioning correctly, or if it is damaged, switch off the voltage supply and return the device to the plant for inspection.

Apply supply voltage to the device if terminal blocks are wired and installed correctly as described in chapter [“Supply voltage and signal contact”](#) on [page 22](#).

■ Shielding ground

Note: The shield ground wire of the twisted pair lines is connected to the front panel as a conductor.

■ Housing



DANGER

HAZARD OF ELECTRIC SHOCK

Never insert sharp objects (small screwdrivers, wires, etc.) into the inside of the product.

Failure to follow these instructions will result in death, serious injury, or equipment damage.



CAUTION

EQUIPMENT OVERHEATING

When installing the device, make sure any ventilation slots remain free. Maintain a clearance of at least 10 cm (3.94 in).

Failure to follow these instructions can result in injury or equipment damage.

Only technicians authorized by the manufacturer are permitted to open the housing.

The housing is grounded via the separate ground screw on the bottom left of the front panel.

- The ventilation slots must not be covered to promote free air circulation.
- Make sure that the electrical installation meets local or nationally applicable safety regulations.
- The clearance between the ventilation slots of the housing and other objects must be at least 10 cm (3.94 in).
- The device must be installed in the vertical position.
- If installed in a living area or office environment, the device must be operated exclusively in switch cabinets with fire protection characteristics in accordance with EN 60950-1.

■ **Environment**

The device may only be operated at the specified surrounding air temperature (temperature of the surrounding air at a distance of up to 5 cm (1.97 in) from the device) and relative air humidity specified in the technical data.

- Install the device in a location where the climatic threshold values specified in the technical data will be observed.
- Use the device only in an environment within the pollution degree specified in the technical data.

■ **General safety instructions**

Electricity is used to operate this equipment. Comply with every detail of the safety requirements specified in the operating instructions regarding the voltages to apply.

See [“Supply voltage” on page 6](#).

- Only qualified personnel should work on this device or in its vicinity. These personnel must be thoroughly familiar with all the hazard messages and maintenance procedures in accordance with this operating manual.
- The proper and safe operation of this device depends on proper handling during transport, proper storage and assembly, and conscientious operation and maintenance procedures.
- Never start operation with damaged components.
- Any work that may be required on the electrical installation may only be carried out by personnel trained for this purpose.

Note: LED or LASER components in compliance with IEC 60825-1 (2007):

CLASS 1 LASER PRODUCT

CLASS 1 LED PRODUCT

■ **National and international safety regulations**

- Make sure that the electrical installation meets local or nationally applicable safety regulations.

■ **CE marking**

The devices comply with the regulations contained in the following European directive(s):

2011/65/EU (RoHS)

Directive of the European Parliament and of the Council on the restriction of the use of certain hazardous substances in electrical and electronic equipment.

2004/108/EC

Directive of the European Parliament and the council for standardizing the regulations of member states with regard to electromagnetic compatibility.

In accordance with the above-named EU directive(s), the EU conformity declaration will be at the disposal of the relevant authorities at the following address:

Schneider Electric
35 rue Joseph Monier
CS30323
92506 Rueil-Malmaison-France

The product can be used in the industrial sector.

- ▶ Interference immunity: EN 61000-6-2:2005
- ▶ Emitted interference: EN 55022:2010

■ **FCC note**

This device complies with part 15 of the FCC rules. Operation is subject to the following two conditions : (1) This device may not cause harmful interference; (2) this device must accept any interference received, including interference that may cause undesired operation.

Appropriate testing has established that this device fulfills the requirements of a class A digital device in line with part 15 of the FCC regulations.

These requirements are designed to provide sufficient protection against interference when the device is being used in a business environment. The device creates and uses high frequencies and can also radiate high frequencies, and if it is not installed and used in accordance with this operating manual, it can cause radio transmission interference. The use of this device in a living area can also cause interference, and in this case the user is obliged to cover the costs of removing the interference.

■ **Instructions for Use in Hazardous Locations**

SUITABLE FOR USE IN CLASS I, DIVISION 2, GROUPS A, B, C AND D HAZARDOUS LOCATIONS, OR NONHAZARDOUS LOCATIONS ONLY.

Peripheral equipment must be suitable for the location it is used in. Use 60/75 °C (140/167 °F) or 75 °C (167 °F) copper (Cu) wire only.

 **WARNING**

EXPLOSION HAZARD

Substitution of any components may impair suitability for CLASS I, DIVISION 2.

Failure to follow these instructions can result in death, serious injury, or equipment damage.

 **WARNING**

EXPLOSION HAZARD

Do not disconnect equipment unless power has been switched off or the area is known to be non-hazardous.

Failure to follow these instructions can result in death, serious injury, or equipment damage.

 **WARNING**

EXPLOSION HAZARD

Do not use USB connector, or connect or disconnect devices from it unless the area is known to be **non**-hazardous.

Failure to follow these instructions can result in death, serious injury, or equipment damage.

CONTROL DRAWING: Hazardous Locations Class I Division 2 Groups A, B, C, D

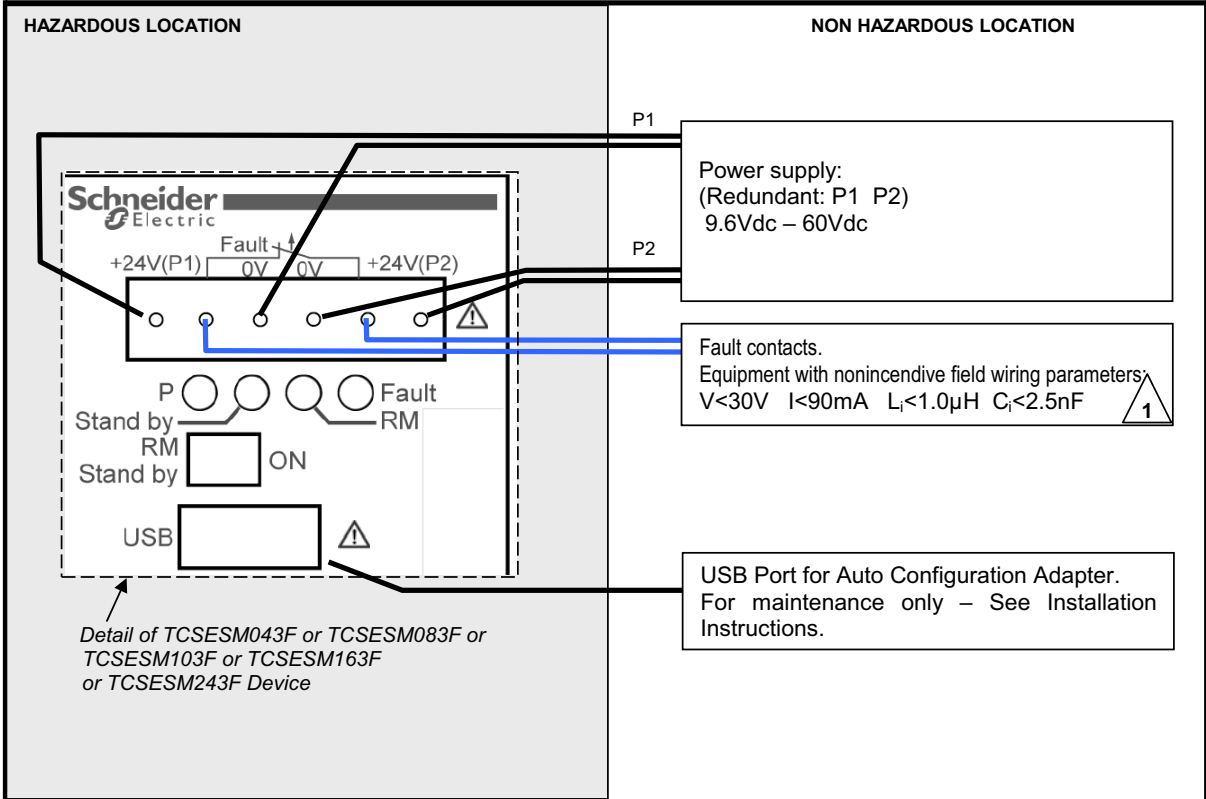

Notes:



The nonincendive field wiring circuit concept allows interconnection of nonincendive field wiring apparatus and associated nonincendive field wiring apparatus using any of the wiring methods permitted for unclassified locations when certain parametric conditions are met.

$$C_a \geq C_i + C_{Cable} ; L_a \geq L_i + L_{Cable}$$

Nonincendive field wiring circuits must be wired in accordance with the National Electrical Code (NEC), NFPA 70, article 501.

Nonincendive Field Wiring Parameters:

Entity Parameters ... for Class I Division 2 Groups A,B,C,D =>	V_{max} [V]	I_{max} [mA]	C_i [nF]	L_i [μH]
Fault contacts	30	90	2.5	1.0



WARNING - EXPLOSION HAZARD – SUBSTITUTION OF COMPONENTS MAY IMPAIR SUITABILITY FOR HAZARDOUS LOCATIONS OR EXPLOSIVE ATMOSPHERES.

WARNING - EXPLOSION HAZARD - DO NOT DISCONNECT EQUIPMENT UNLESS POWER HAS BEEN SWITCHED OFF OR THE AREA IS KNOWN TO BE NON-HAZARDOUS.

DO NOT OPEN WHEN ENERGIZED.

CONTROL DRAWING for TCSESM043F, TCSESM083F, TCSESM103F, TCSESM163F and TCSESM243F Devices

Size A4	Document No.: 000157671DNR	Rev. 0
Date: 2011-09-21	Sheet 1 of 1	

1 Device description

1.1 General device description

A TCSESM switch is a compact, heavy-duty device suitable for industrial applications which can be installed on a standard DIN Rail. The switches are available in 4, 8, 10, 16 and 24 ports combinations. Two of these ports, uplinks, usually used to implement the ring architectures, could be available in Copper or Fiber (multimode, singlemode) and in 10/100 Mbps or Gigabit speeds.

The 10-60VDC/18-30VAC operating voltage is supplied via a plug-in terminal block with two connections to wire primary and redundant voltage if necessary. An alarm relay allows reporting diagnostic information (P/S, Link signal, Redundancy health) to Control systems. Integrated LEDs allow fast on-site installation and troubleshooting.

Depending on the device variant, you can choose various media to connect terminal devices and other infrastructure components:

- ▶ twisted pair cable
- ▶ multimode F/O
- ▶ singlemode F/O

The twisted pair ports support:

- ▶ Autocrossing
- ▶ Autonegotiation
- ▶ Autopolarity

There are convenient options for managing the device. Administer your devices via:

- ▶ a Web browser
- ▶ Telnet
- ▶ a V.24 interface (locally on the device)

Product configuration data can be provided by:

- ▶ diagnosis displays
- ▶ displaying the operating parameters
- ▶ a label area for the IP address

The devices provide you with a large range of functions:

- ▶ Redundancy functions
 - ▶ Rapid Spanning Tree Protocol (RSTP)
 - ▶ HIPER-Ring
 - ▶ Redundant coupling
 - ▶ Redundant power supply
 - ▶ Media Redundancy Protocol (MRP)

- ▶ Security
 - ▶ Protection from unauthorized access
 - ▶ Blocking of unauthorized messages (MAC or IP based)
- ▶ Synchronized system time in the network
- ▶ Network load control
- ▶ Operation diagnosis
- ▶ Diagnostics (hardware self-testing)
- ▶ Reset
- ▶ Priority
- ▶ VLAN
- ▶ Topology Discovery
- ▶ Web-based Interface
- ▶ Command Line Interface CLI
- ▶ SNMP
- ▶ Real Time Clock

1.2 Device versions

1.2.1 Device versions

Part Number	Part Number	Description
4 Port Version	TCSESM043F23F0	4 10/100 TX Managed
	TCSESM043F1CU0	3 10/100 TX 1 100 FX-MM Managed
	TCSESM043F2CU0	2 10/100 TX 2 100 FX-MM Managed
	TCSESM043F1CS0	3 10/100 TX 1 100 FX-SM Managed
	TCSESM043F2CS0	2 10/100 TX 2 100 FX-SM Managed
8 Port Version	TCSESM083F23F0	8 10/100 TX Managed
	TCSESM083F1CU0	7 10/100 TX 1 100 FX-MM Managed
	TCSESM083F2CU0	6 10/100 TX 2 100 FX-MM Managed
	TCSESM083F1CS0	7 10/100 TX 1 100 FX-SM Managed
	TCSESM083F2CS0	6 10/100 TX 2 100 FX-SM Managed
16 Port Version	TCSESM163F23F0	16 10/100 TX Managed
	TCSESM163F2CU0	14 10/100 TX 2 100 FX-MM Managed
	TCSESM163F2CS0	14 10/100 TX 2 100 FX-SM Managed
24 Port Version	TCSESM243F2CU0	22 10/100 TX 2 100 FX-MM Managed
Gigabit - 10 Port Version	TCSESM103F23G0	8 10/100 TX 2 10/100/1000 TX Managed
	TCSESM103F2LG0	8 10/100 TX, 2 1000 SFP (fiber) Managed
		Note: This product ships with open sockets (SFP) on the fiber ports. In order to use these ports, order 1 or 2 fiber modules in any combination (see below).
Fiber Media Modules for Gigabit	TCSEAAF1LFU00	fiber module SFP-SX/LC
	TCSEAAF1LFS00	fiber module SFP-LX/LC
	TCSEAAF1LFH00	fiber module SFP-LH/LC
Accessories	TCSEAM0100 Adapter	Memory Back-up Adapter
	490NTRJ11 Cable	Terminal 490NTRJ11 cable

1.2.2 Examples of switch versions

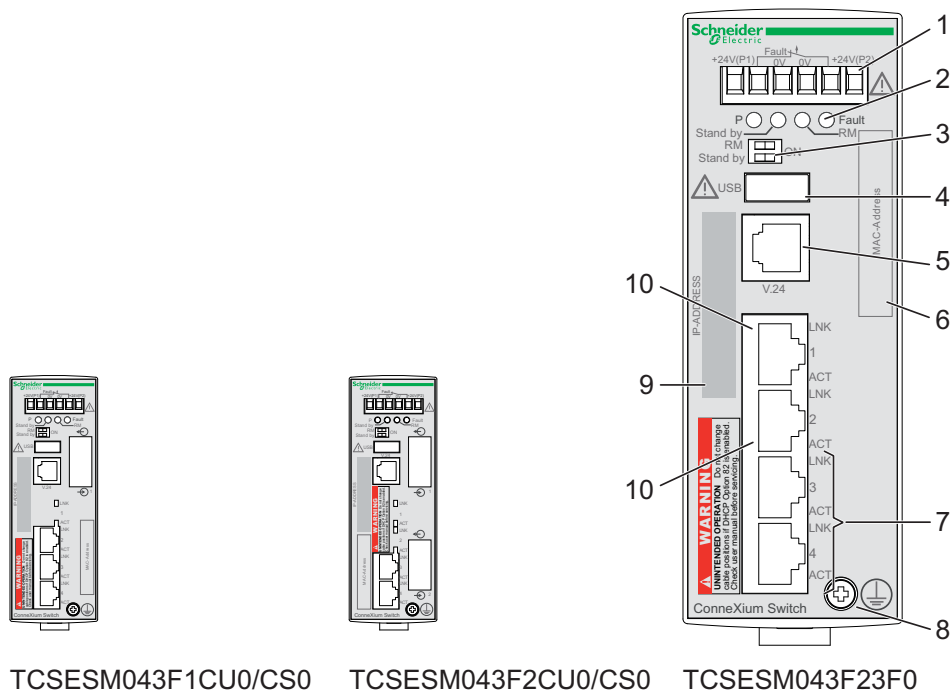
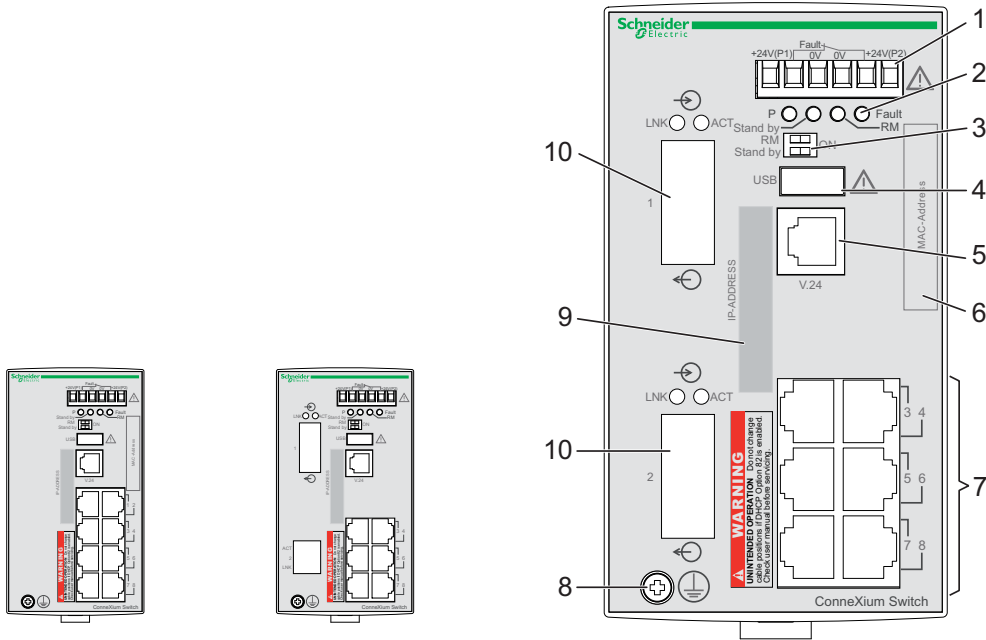

Figure 1: The figure shows the 4-port versions of the TCSESM.

- 1 – plug-in terminal block, 6-pin
- 2 – LED display elements
- 3 – 2-pin DIP switch
- 4 – USB interface
- 5 – V.24 connection for external management
- 6 – MAC address field
- 7 – ports in compliance with 10/100BASE-T(X) (RJ45 connections)
- 8 – protective ground (PE)
- 9 – IP address field
- 10 – port 1 + port 2, free choice of connections:
 - Twisted Pair T(X), RJ45, 10/100 Mbit/s
 - Multimode FX, DSC, 100 Mbit/s
 - Singlemode FX, DSC, 100 Mbit/s



TCSESM083F23F0 TCSESM083F1CU0/CS0 TCSESM083F2CU0/CS0/CX0

Figure 2: The figure shows the 8-port versions of the TCSESM.
 1 to 9 – see [fig. 1](#)
 10 – port 1 + port 2:
 Twisted Pair T(X), RJ45, 10/100 Mbit/s
 Multimode FX, DSC, 100 Mbit/s
 Singlemode FX, DSC, 100 Mbit/s

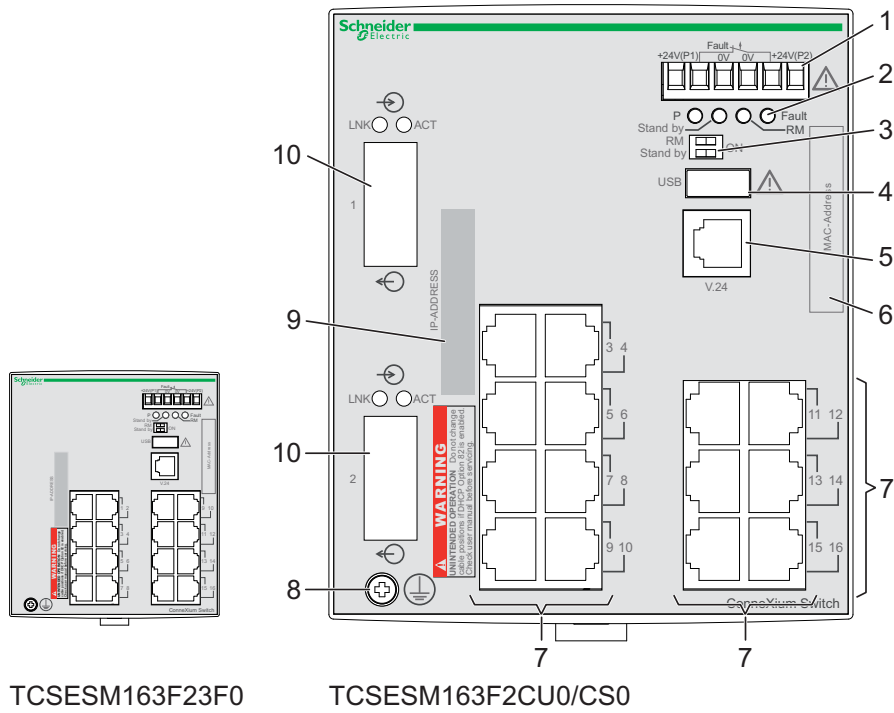

Figure 3: The figure shows the 16-port versions of the TCSESM.

1 to 9 – see fig. 1

10 – port 1 + port 2:

Twisted Pair T(X), RJ45, 10/100 Mbit/s

Multimode FX, DSC, 100 Mbit/s

Singlemode FX, DSC, 100 Mbit/s

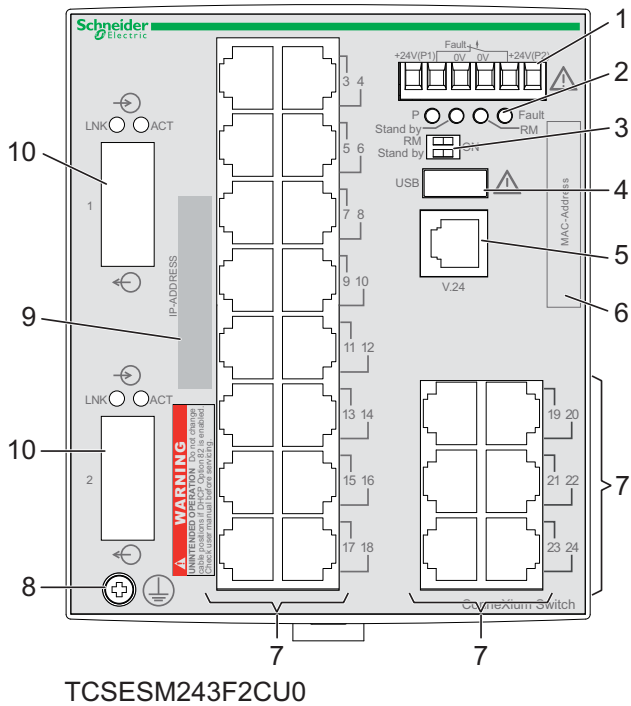

Figure 4: The figure shows the 24-port versions of the TCSESM.
 1 to 9 – see fig. 1
 10 – port 1 + port 2, free choice of connections:
 Multimode FX, DSC, 100 Mbit/s

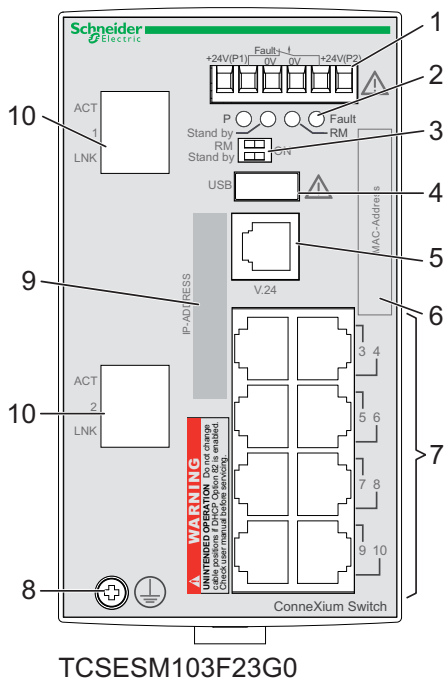

Figure 5: The figure shows the 10-port (gigabit) versions of the TCSESM.
 1 to 9 – see fig. 1
 10 – port 1 + port 2:
 Twisted Pair T(X), RJ45, 10/100/1000 Mbit/s
 SX/LX, SFP-shaft, 1000 Mbit/s

2 Assembly and start-up

2.1 Safety instructions

■ Staff qualification requirements

Only appropriately qualified staff should work on or near this equipment. Such staff must be thoroughly acquainted with all the hazard messages and maintenance measures contained in these operating instructions.

The proper and safe operation of this equipment assumes proper transport, appropriate storage and assembly, and careful operation and maintenance.

Qualified staff are persons familiar with setting up, assembling, installation, starting up, and operating this product, and who have appropriate qualifications to cover their activities, such as:

- ▶ knowledge of how to switch circuits and equipment/systems on and off, ground them, and identify them in accordance with current safety standards
- ▶ training or instruction in accordance with current safety standards of using and maintaining appropriate safety equipment
- ▶ first aid training

■ Recycling note

After usage, this product must be disposed of properly as electronic waste, in accordance with the current disposal regulations of your county, state and country.

2.2 Installing the device

2.2.1 Overview of installation

Two or more devices configured with the same IP address can cause unpredictable operation of your network.

WARNING

UNINTENDED EQUIPMENT OPERATION

Establish and maintain a process for assigning unique IP addresses to all devices on the network.

Failure to follow these instructions can result in death, serious injury, or equipment damage.

WARNING

UNINTENDED OPERATION

Do not change cable positions if DHCP Option 82 is enabled. Check the Basic Configuration user manual before servicing (refer to DHCP OPTION 82 topic).

Failure to follow these instructions can result in death, serious injury, or equipment damage.

On delivery, the device is ready for operation.

The following steps should be performed to install and configure a switch:

- ▶ Unpacking and checking
- ▶ Insert data in label area
- ▶ Adjust DIP switch settings
- ▶ Connect the terminal block for voltage supply and signal contact and connect the supply voltage
- ▶ Install the device on the DIN rail, grounding
- ▶ Install the terminal block, start-up procedure
- ▶ Connecting the data lines

2.2.2 Unpacking and checking

- Check that the contents of the package are complete ([see page 37 “Scope of delivery”](#)).
- Check the individual parts for transport damage.

2.2.3 Installing the SFP modules (optional)



Figure 6: Fast Ethernet / Gigabit Ethernet fiber optic SFP module

- Before attaching an SFP module, first remove the protective cap over the socket.
- Push the SFP module with the lock closed into the socket until it latches audibly in place.

2.2.4 Insert data in label area

The information field for the IP address on the front of the device helps you to structure your network installation clearly.

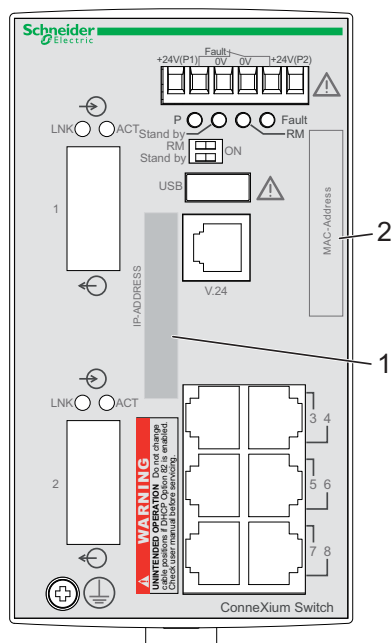

Figure 7: Label area for IP address of device
1 – IP address of device (label area)
2 – MAC address of device (label)

2.2.5 Adjust DIP switch settings

The 2-pin DIP switch on the front panel of the device gives you the following options:



Figure 8: 2-pin DIP switch

Switch RM position	Switch stand-by position	Ring redundancy	Coupling switch	Ring Manager	Coupling Manager	Ring port	Control port	Coupling port	Software configuration
OFF	OFF	on	on	off	off	1 + 2			
ON	OFF	on	on	on	off	1 + 2			
OFF	ON	on	on	off	on	1 + 2	3	4	
ON	ON								SW config. has priority over DIP switch configuration

Delivery state: both DIP switches “ON”.

- Before starting operation of the device, check whether the default settings of the DIP switch correspond to your requirements.

2.2.6 Supply voltage and signal contact

■ Supply voltage

⚠ DANGER

HAZARD OF ELECTRIC SHOCK OR BURN

When the module is operated with direct plug-in power units, use only:

- SELV supply units that comply with IEC 60950/EN 60950 and
- (in USA and Canada) Class 2 power units that comply with applicable national or regional electrical codes

Connect the ground wire to the PE terminal (where applicable) before you establish any further connections. When you remove connections, disconnect the ground wire last.

Failure to follow these instructions will result in death, serious injury, or equipment damage.

Redundant power supplies can be used. Both inputs are uncoupled. There is no distributed load. With redundant supply, the power supply unit supplies the device only with the higher output voltage. The supply voltage is electrically isolated from the housing.

You can choose between DC or AC voltage when connecting the supply voltage. You use the +24V and 0V pins to connect the AC voltage (see fig. 9).

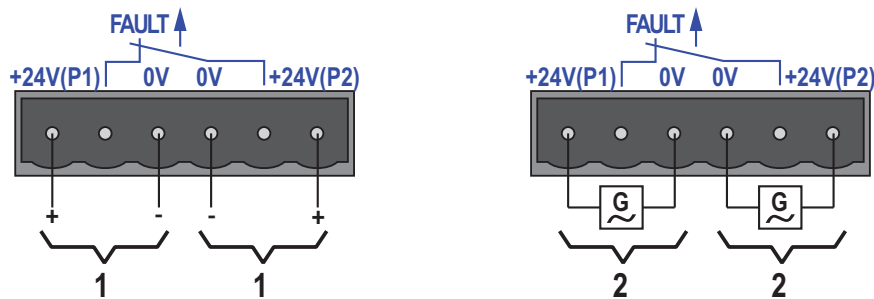

Figure 9: Connecting the supply voltage at the 6-pin terminal block
 1 – DC voltage, voltage range: 9.6 V DC to 60 V DC
 2 – AC voltage, voltage range: 18 V AC to 30 V AC

■ Signal contact

- ▶ The signal contact (“FAULT”, for pin assignment of terminal block, see fig. 9) monitors the functioning of the device, thus enabling remote diagnostics. You can specify the type of function monitoring in the Management.
- ▶ You can also use the switch Web page to switch the signal contact manually and thus control external devices.

A break in contact is used to report the following conditions via the potential-free signal contact (relay contact, closed circuit):

- ▶ The detected inoperability of at least one of the two voltage supplies (voltage supply 1 or 2 is below the threshold value).
- ▶ The loss of connection at at least one port. The report of the link status can be masked by the Management for each port. In the delivery state, link status monitoring is deactivated.
- ▶ The loss of ring redundancy reserve.
- ▶ A detected error during the self-test.

The following condition is also reported in RM mode:

- ▶ Ring redundancy reserve is available. On delivery, there is no ring redundancy monitoring.
- Pull the terminal block off the device and connect the power supply and signal lines.

2.2.7 Installing the device on the DIN rail, grounding

■ Mounting on the DIN rail

- Mount the device on a 35 mm DIN rail in accordance with DIN EN 60175.
- Attach the upper snap-in guide of the device into the DIN rail and press it down against the DIN rail until it snaps into place.

Note: The shield ground wire of the twisted pair lines is connected to the front panel as a conductor.

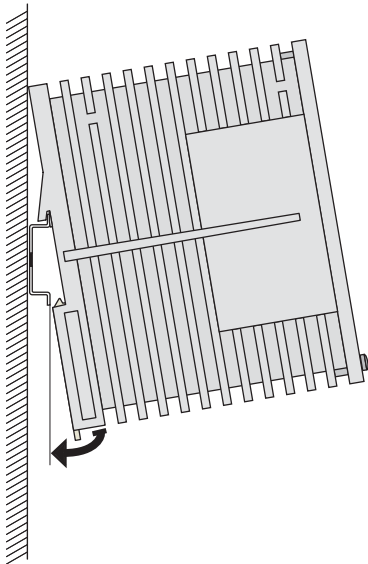

Figure 10: Mounting on the DIN rail

■ Grounding

The device is grounded by the separate ground screw on the front panel.

2.2.8 Dimension drawings

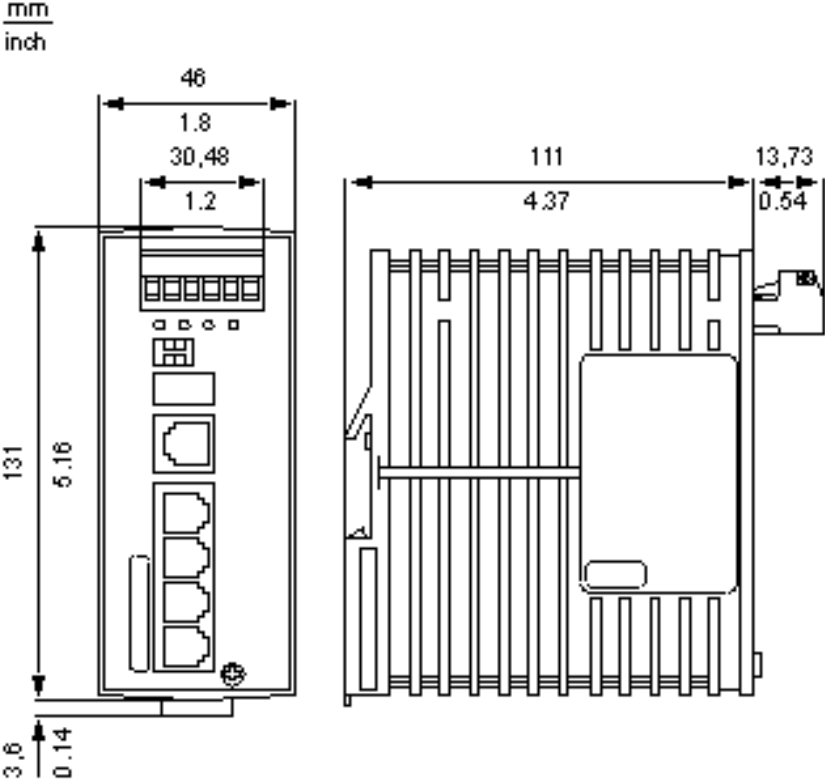

Figure 11: 4 Port Versions

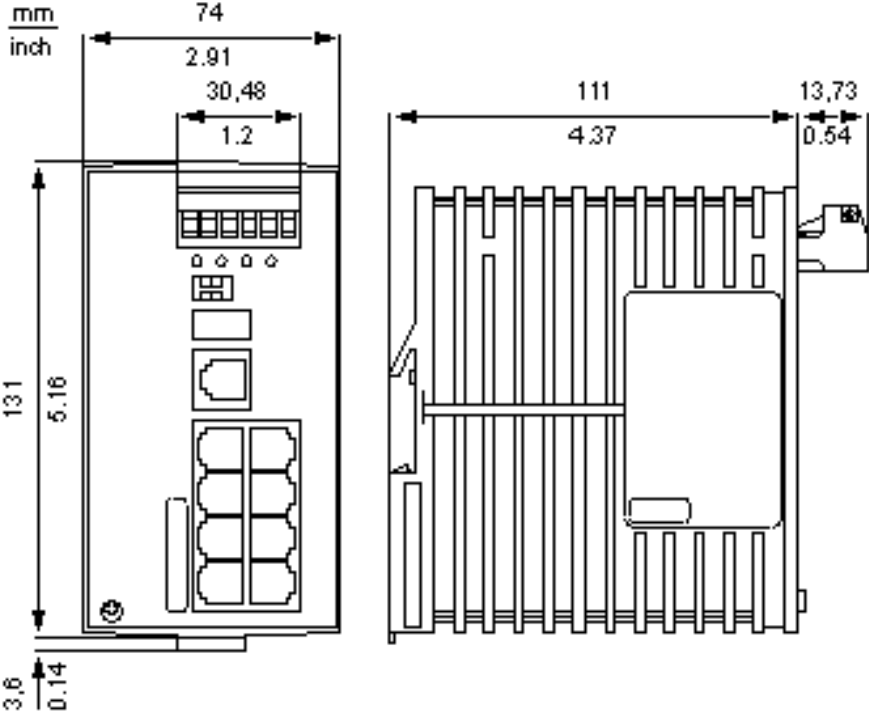

Figure 12: 8 and 10 Port Versions

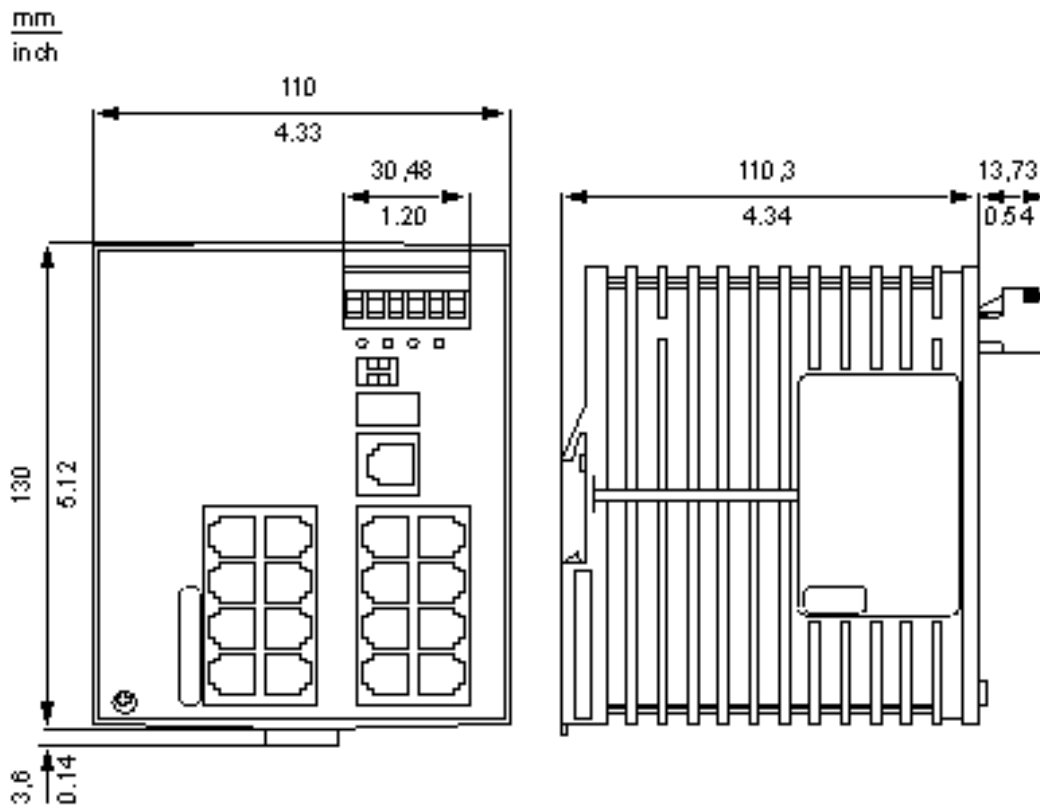

Figure 13: 16 and 24 Port Versions

2.2.9 Installing the terminal block, start-up procedure

- Mount the terminal block for the voltage supply and signal contact on the front of the device by snapping the lock into place.

Connecting the voltage supply via the terminal block starts the operation of the device.

2.2.10 Connecting the data lines

You can connect terminal devices and other segments on the ports of the device via twisted pair cables or F/O cables.

- Install the data lines according to your requirements.

■ 10/100 Mbit/s twisted pair connection

These connections are RJ45 sockets.

10/100 Mbit/s TP ports enable the connection of terminal devices or independent network segments according to the IEEE 802.3 10BASE-T/100BASE-TX standard.

These ports support:

- ▶ Autonegotiation (data rate and duplex mode)
- ▶ Autopolarity
- ▶ Autocrossing (if autonegotiation is activated)

▶ 100 Mbit/s half-duplex mode, 100 Mbit/s full duplex mode

▶ 10 Mbit/s half-duplex mode, 10 Mbit/s full duplex mode

Delivery state: autonegotiation activated

The socket housing is electrically connected to the front panel.

Figure	Pin	Function
	1+2	One line pair: receiver path
	3+6	One line pair: sender path
	4,5,7,8	Not used

Table 1: Pin assignment of a TP/TX interface in MDI-X mode, RJ45 socket

■ 10/100/1000 Mbit/s twisted pair connection

These connections are RJ45 sockets.

10/100/1000 Mbit/s TP ports enable the connection of terminal devices or independent network segments according to the IEEE 802.3 10BASE-T/100BASE-TX/1000BASE-T standard.

These ports support:

- ▶ Autonegotiation
(data rate and duplex mode)
- ▶ Autopolarity
- ▶ Autocrossing (if autonegotiation is activated)
- ▶ 1000 Mbit/s full duplex
- ▶ 100 Mbit/s half-duplex mode, 100 Mbit/s full duplex mode
- ▶ 10 Mbit/s half-duplex mode, 10 Mbit/s full duplex mode

Delivery state: autonegotiation activated

The socket housing is electrically connected to the front panel.

The pin assignment corresponds to MDI-X.

Figure	Pin	Function
	1	BI_DB +
	2	BI_DB -
	3	BI_DA +
	4	BI_DD +
	5	BI_DD -
	6	BI_DA -
	7	BI_DC +
	8	BI_DC -

Table 2: Pin assignment of a 1000 MBit/s TP interface in MDI-X mode, RJ45 socket

■ **100 Mbit/s F/O connection**

These connections are DSC connectors.

100 MBit/s F/O ports enable the connection of terminal devices or independent network segments in compliance with the IEEE 802.3 100BASE-FX standard.

These ports support:

- ▶ Full or half duplex mode

Delivery state: full duplex FDX

Note: Make sure that the SM ports are only connected with SM ports, and MM ports only with MM ports.

■ **1 Gbit/s F/O connection**

These ports are SFP slots.

1 Gbit/s F/O ports enable the connection of terminal devices or independent network segments according to the IEEE 802.3 1000BASE-SX/1000BASE-LX standard.

These ports support:

- ▶ Autonegotiation
- ▶ Full duplex mode

Delivery state: autonegotiation activated

Note: Make sure that the LH ports are only connected with LH ports, SX ports are only connected with SX ports, and LX ports only with LX ports.

2.3 Display elements

After the operating voltage is set up, the software starts and initializes itself. Afterwards, the device performs a self-test. During this process, various LEDs light up. The process takes around 60 seconds.

■ Device state

These LEDs provide information about conditions which affect the operation of the whole device.



Figure 14: Device status LEDs

P - Power (green/yellow LED)	
Glowing green	Both supply voltages are on
Glowing yellow	There is only one supply voltage (P1 or P2) on
Not glowing	Supply voltages P1 and P2 are too low
FAULT - detected error, signal contact (red LED) ^a	
Glowing red	The signal contact is open, i.e. it is reporting a detected error.
Not glowing	The signal contact is closed, i.e. it is not reporting a detected error.
a. If the manual adjustment is active on the "FAULT" signal contact, then the detected error display is independent of the setting of the signal contact.	
RM - Ring Manager (green/yellow LED)	
Glowing green	RM function active, redundant port disabled
Glowing yellow	RM function active, redundant port enabled
Not glowing	RM function not active
Flashing green	Incorrect configuration of the HIPER-Ring (e.g. the ring is not connected to the ring port).
Stand-by	
Glowing green	Stand-by mode enabled
Not glowing	Stand-by mode not enabled

■ Port state

The green and yellow LEDs at the individual port display port-related information. During the boot phase, these LEDs are used to display the status of the boot procedure.

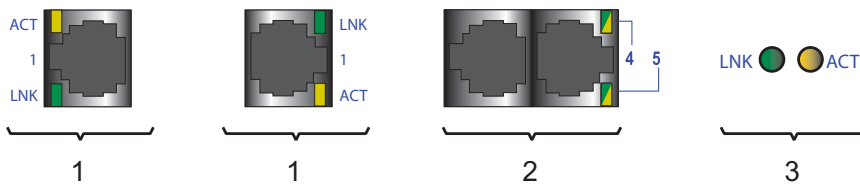

Figure 15: Port status LEDs

1 – Port status LEDs for isolated or single-row RJ45 sockets: one green and one yellow LED per port.

2 – Port status LEDs for double-row RJ45 sockets: one LED per port, glowing/flashing either green or yellow.

3 – Port status LEDs for DSC, SFP

LED	Display	Color	Activity	Meaning
LNK	Link status	Green	Lights up	Valid connection
			None	No valid connection
			flashes (1 time/s)	Port is switched to stand by
			flashes (3 times/s)	Port is disabled
ACT	data	Yellow	None	No data reception at this port
			Flashing	Data reception at this port

2.4 Basic set-up

The IP parameters must be entered when the device is installed for the first time.

The device provides the following options for configuring IP addresses:

- ▶ Configuration via V.24 connection
- ▶ Configuration via the switch configurator software
- ▶ Configuration via BOOTP
- ▶ Configuration via DHCP
- ▶ Configuration via the Memory Back-up Adapter (TCSEAM 0100)

Further information on the basic settings of the device can be found in the “Basic Configuration” user manual on the CD ROM.

■ Default settings

- ▶ IP address: The device looks for the IP address using DHCP
- ▶ Password for management:
 - Login: user; password: public (read only)
 - Login: admin; password: private (read and write)
- ▶ V.24 data rate: 9,600 Baud
- ▶ Ring redundancy: disabled
- ▶ Ethernet ports: link status is not evaluated (signal contact)
- ▶ Optical 100 Mbit/s ports: 100 Mbit/s, full duplex
- ▶ All other ports: autonegotiation
- ▶ Ring Manager disabled (DIP switch RM and stand-by: ON)
- ▶ Stand-by coupling disabled (DIP switch RM and stand-by: ON)
 - Port 4 = control port, port 3 = coupling port for red. Ring coupling
- ▶ Rapid Spanning Tree enabled

■ USB interface

The USB socket has an interface for the local connection of a Memory Back-up Adapter (EAM). The EAM is used for saving/loading the configuration data and diagnostic information, and for loading the software.

Figure	Pin	Operation
	1	VCC (VBus)
	2	- Data
	3	+ Data
	4	Ground (GND)

Table 3: Pin assignment of the USB interface

■ V.24 interface (external management)

The V.24 interface is an RJ11 socket.

The V.24 interface is a serial interface which allows you to connect the following devices locally:

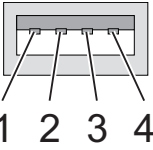
- ▶ An external management station (VT100 terminal or PC with appropriate terminal emulation). This enables you to set up a connection to the Command Line Interface (CLI) and to the system monitor.
- ▶ A Memory Back-up Adapter (TCSEAM0100)

VT 100 terminal settings

Speed	9,600 Baud
Data	8 bit
Stopbit	1 bit
Handshake	off
Parity	none

The socket housing is electrically connected to the front panel of the device.

The V.24 interface is not electrically isolated from the supply voltage.

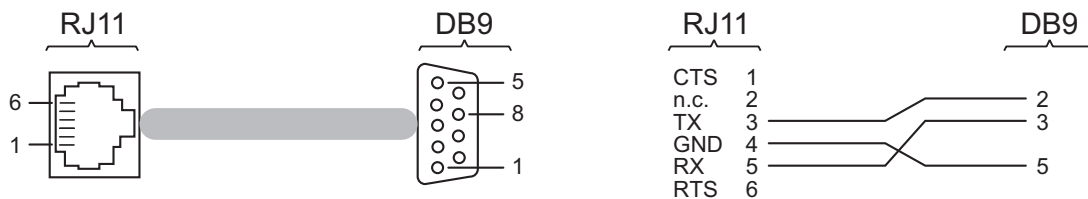

Figure 16: Pin assignment of the V.24 interface and the DB9 connector

Note: You can order the terminal cable separately (ref #: 490NTRJ11).

You will find a description of the V.24 interface in the “Basic Configuration User Manual” on the CD-ROM.

2.5 Maintenance

- Depending on the degree of pollution in the operating environment, check at regular intervals that the ventilation slots in the device are not obstructed.
Operate this device according to the specifications (see [“Technical data”](#)).

2.6 Disassembly

■ Removing the device from the DIN rail

- To take the device off the DIN rail, insert a screwdriver horizontally under the housing into the locking slide, pull it (without tipping the screwdriver) downwards and lift the device upwards.

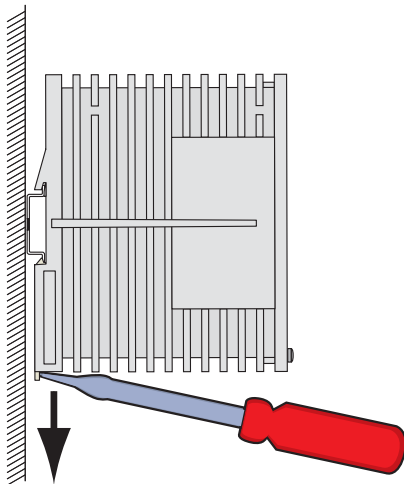

■ Disassembling the SFP modules

- Pull the module out of the socket by means of the opened lock.
- Close the module with the protective cap.



3 Technical data

■ General technical data

Dimensions W x H x D	TCSESM04	47 mm x 131 mm x 111 mm 1.85 in x 5.16 in x 4.3 in
	TCSESM08 and TCSESM10	74 mm x 131 mm x 111 mm 2.91 in x 5.16 in x 4.37 in
	TCSESM16 and TCSESM24	111 mm x 131 mm x 111 mm 4.37 in x 5.16 in x 4.37 in
Weight	TCSESM04	400 g
	TCSESM08	410 g
	TCSESM10	410 g
	TCSESM16	600 g
	TCSESM24	610 g
Power supply	Operating voltage	9.6 to 60 V DC or 18 to 30 V AC Safety extra-low voltage (SELV), redundant inputs disconnected. Relevant for North America: NEC Class 2 power source max. 5A.
Overload current protection at input		Non-replaceable fuse
Insulation voltage between operating voltage connections and housing		800 V DC Protective elements limit the insulation voltage to 90 V DC (1 mA)
"FAULT" signal contact	Switching current	max. 1 A, SELV
	Switching voltage	max. 60 V DC or max. 30 V AC, SELV
Environment	Storage temperature (ambient air)	-40 °C (-40 °F) to +80 °C (+176 °F)
	Humidity	10% to 95% (non-condensing)
	Air pressure	Up to 2000 m (795 hPa), higher altitudes on request
Operating temperature		0 °C (+32 °F) to +60 °C (+140 °F)
Pollution degree		2
Protection classes	Laser protection	Class 1 according to IEC 60825- 1(2007)
	Degree of protection	IP 20

■ EMC and immunity

EMC compliance – IEC/EN 61000-6-2:2005 EMI TYPE tests, test acc. to:		
IEC/EN 61000-4-2	Electrostatic discharge	
	Contact discharge	8 kV
IEC/EN 61000-4-3	Electromagnetic field	
	80 - 3,000 MHz	20 V/m
IEC/EN 61000-4-4	Fast transients (burst)	
	Power line	4 kV
	Data line	4 kV
IEC/EN 61000-4-5	Voltage surges	
	Power line, line / line	1 kV
	Power Line, line / ground	2 kV
	Data line	2 kV
IEC/EN 61000-4-6	Line-conducted interference voltages	
	10 kHz - 150 kHz	3 V
	150 kHz - 80 MHz	10 V
EN 61000-4-9	Impulse-shaped magnetic fields	300 A/m
EMC emitted interference		
EN 55022	Class A	Yes
FCC 47 CFR Part 15	Class A	Yes
German Lloyd	Classification + Construction Guidelines VI-7-3 Part 1 Ed.2001	Yes
Stability		
Vibration	IEC 60068-2-6 Test FC test level according to IEC 61131-2	Yes
Shock	IEC 60068-2-27 Test Ea test level according to IEC 61131-2	Yes

■ Network range

TP port	
Length of a twisted pair segment	max. 100 m/328 ft (for cat5e cable)

Table 4: TP port 10BASE-T / 100BASE-TX / 1000BASE-T

Description	Wave length	Fiber	System attenuation	Expansion	Fiber data
Multimode FX, DSC, 10/100 Mbit/s	1300 nm	50/125 µm	0-8 dB	0-5 km	1.0 dB/km, 800 MHz*km
Multimode FX, DSC, 10/100 Mbit/s	1300 nm	62,5/125 µm	0-11 dB	0-4 km	1.0 dB/km, 500 MHz*km
Singlemode FX, DSC, 10/100 Mbit/s	1300 nm	9/125 µm	0-16 dB	0-30 km	0.4 dB/km; 3.5 ps/(nm*km)

Table 5: F/O port 100BASE-FX

Description SFP-...	Wave length	Fiber	System attenuation	Expansion	Fiber data
-SX/LC...	MM 850 nm	50/125 µm	0-7.5 dB	0-550 m	3.0 dB/km, 400 MHz*km
-MX/LC...	MM 1310 nm	50/125 µm	0-8 dB	2 km ^a	1.0 dB/km, 500 MHz*km
-MX/LC	MM 1310 nm	62.5/125 µm	0-8 dB	1 km	1.0 dB/km, 500 MHz*km
-LX/LC...	MM 1310 nm ^b	50/125 µm	0-11 dB	0-550 m	1.0 dB/km, 800 MHz*km
-LH/LC...	LH 1550 nm	9/125 µm	6-22 dB	24-72 km	0.25 dB/km; 19 ps/(nm*km)
-LX+/LC	SM 1310 nm	9/125 µm	5-20 dB	14-42 km	0.4 dB/km; 3.5 ps/(nm*km)

Table 6: Fiber port 1000BASE-FX (SFP fiber optic Gigabit Ethernet Transceiver)

- a. Distances up to 3 km reachable, 1000 MHz*km (1300 nm)
- b. With F/O adapter compliant with IEEE 802.3-2002 clause 38 (single-mode fiber offset-launch mode conditioning patch cord)

MM = Multimode, SM = Singlemode, LH = Singlemode Longhaul

■ Power consumption/power output

Device name	Device model	Maximum power consumption	Power output
TCSESM04	2xTX port	5.3 W	18.1 Btu (IT)/h
TCSESM04	1xFX port, 1xTX port	6.5 W	22.2 Btu (IT)/h
TCSESM04	2xFX port	7.7 W	26.3 Btu (IT)/h
TCSESM08	2xTX port	5.3 W	18.1 Btu (IT)/h
TCSESM08	1xFX port, 1xTX port	6.5 W	22.2 Btu (IT)/h
TCSESM08	2xFX port	7.7 W	26.3 Btu (IT)/h
TCSESM10 (with gigabit ports)	2xTX port	8.9 W	30.4 Btu (IT)/h
TCSESM10 (with gigabit ports)	2xFX port	8.3 W	28.4 Btu (IT)/h
TCSESM16	2xTX port	9.4 W	32.1 Btu (IT)/h
TCSESM16	2xFX port	11.8 W	40.3 Btu (IT)/h
TCSESM24	2xFX port	14.5 W	52.9 Btu (IT)/h

Table 7: Power input/output for the TCSESM devices

■ Recommended fuses

Device name	Fuse
TCSESM04xx	1.5 A, slow/delay fuse
TCSESM08xx	1.5 A, slow/delay fuse
TCSESM10xx	2.0 A, slow/delay fuse
TCSESM16xx	2.0 A, slow/delay fuse
TCSESM24xx	3.0 A, slow/delay fuse

■ Scope of delivery

Device	Scope of delivery
TCSESMxx	Device
	Terminal block for supply voltage and signal contact
	CD-ROM (includes user technical documentation)



■ Order numbers/product description

Part Number	Part Number	Description
4 Port Version	TCSESM043F23F0	4 10/100 TX Managed
	TCSESM043F1CU0	3 10/100 TX 1 100 FX-MM Managed
	TCSESM043F2CU0	2 10/100 TX 2 100 FX-MM Managed
	TCSESM043F1CS0	3 10/100 TX 1 100 FX-SM Managed
	TCSESM043F2CS0	2 10/100 TX 2 100 FX-SM Managed
8 Port Version	TCSESM083F23F0	8 10/100 TX Managed
	TCSESM083F1CU0	7 10/100 TX 1 100 FX-MM Managed
	TCSESM083F2CU0	6 10/100 TX 2 100 FX-MM Managed
	TCSESM083F1CS0	7 10/100 TX 1 100 FX-SM Managed
	TCSESM083F2CS0	6 10/100 TX 2 100 FX-SM Managed
16 Port Version	TCSESM163F23F0	16 10/100 TX Managed
	TCSESM163F2CU0	14 10/100 TX 2 100 FX-MM Managed
	TCSESM163F2CS0	14 10/100 TX 2 100 FX-SM Managed
24 Port Version	TCSESM243F2CU0	22 10/100 TX 2 100 FX-MM Managed
Gigabit - 10 Port Version	TCSESM103F23G0	8 10/100 TX 2 10/100/1000 TX Managed
	TCSESM103F2LG0	8 10/100 TX, 2 1000 SFP (fiber) Managed
		Note: This product ships with open sockets (SFP) on the fiber ports. In order to use these ports, order 1 or 2 fiber modules in any combination (see below).
Fiber Media Modules for Gigabit	TCSEAAF1LFU00	fiber module SFP-SX/LC
	TCSEAAF1LFS00	fiber module SFP-LX/LC
	TCSEAAF1LFH00	fiber module SFP-LH/LC
Accessories	TCSEAM0100 Adapter	Memory Back-up Adapter
	490NTRJ11 Cable	Terminal 490NTRJ11 cable

■ Underlying norms and standards

Standard	
EN 10155	Declaration (railroad)
EN 50121-4	Railway applications - EMC - emitted interference and interference immunity for signal and telecommunication systems
EN 55022	IT equipment – radio interference characteristics
EN 61000-6-2	Generic norm – immunity in industrial environments
EN 61131-2	Programmable logic controllers
FCC 47 CFR Part 15	Code of Federal Regulations
EN 60950-1	Safety for the installation of IT equipment
IEC/EN 61850-3	Communications networks and systems in substations
IEEE 1613	Standard Environment and Testing Requirements for Communication Networking Devices in Electric Power Substations

■ Certifications

Standard	
cUL 508 / CSA C22.2 No.142	Safety for Industrial Control Equipment 
ISA 12.12.01 / CSA C22.2 No.213	Electrical Equipment for Use in Class I and Class II, Div.2 and Class III Hazardous (Classified) Locations 
Germanischer Lloyd	Ship Applications - Classification and Construction Guidelines VI-7-3 Part 1 Ed.2003

The TCSESM switches have CE certifications.

