

# ConneXium

## TCSEFEA Tofino Firewall Installation Manual

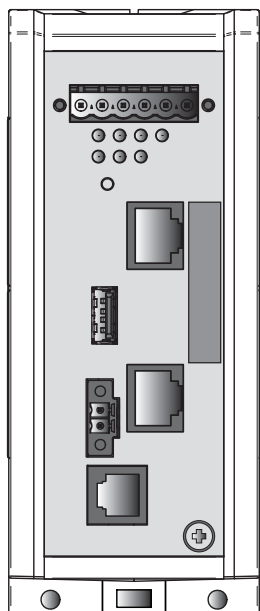

TCSEFEA23F3F22



# Contents

	<b>About this Manual</b>	<b>4</b>
	<b>Key</b>	<b>5</b>
	<b>Safety instructions</b>	<b>5</b>
<b>1</b>	<b>Description</b>	<b>10</b>
1.1	General device description	10
<b>2</b>	<b>Assembly and start-up</b>	<b>12</b>
2.1	Safety instructions	12
2.2	Installing the device	12
2.2.1	Overview of installation	13
2.2.2	Unpacking and checking	13
2.2.3	Terminal block for supply voltage and signal contact	13
2.2.4	Connecting the terminal block, start-up procedure	15
2.2.5	Wiring the digital input (optional)	15
2.2.6	Installing the device on the DIN rail, grounding	15
2.2.7	Connecting the data lines	16
2.2.8	Connection to the network	17
2.3	Display elements	17
2.3.1	Device state	17
2.4	Controls	18
2.5	Basic set-up	19
2.5.1	USB interface	19
2.5.2	V.24 interface	21
2.6	Configuration	21
2.7	Operating Modes	21
2.8	Maintenance	22
2.9	Disassembly	22
<b>3</b>	<b>Technical data</b>	<b>24</b>

# About this Manual

## Validity Note

The data and illustrations found in this book are not binding. We reserve the right to modify our products in line with our policy of continuous product development. The information in this document is subject to change without notice and should not be construed as a commitment by Schneider Electric.

## Product Related Information

Schneider Electric assumes no responsibility for any errors that may appear in this document. If you have any suggestions for improvements or amendments or have found errors in this publication, please notify us.

No part of this document may be reproduced in any form or by any means, electronic or mechanical, including photocopying, without express written permission of Schneider Electric.

All pertinent state, regional, and local safety regulations must be observed when installing and using this product. For reasons of safety and to ensure compliance with documented system data, only the manufacturer should perform repairs to components.

When devices are used for applications with technical safety requirements, please follow the relevant instructions.

Failure to use Schneider Electric software or approved software with our hardware products may result in improper operating results.

Failure to observe this product related warning can result in injury or equipment damage.

## User Comments

We welcome your comments about this document. You can reach us by e-mail at [techpub@schneider-electric.com](mailto:techpub@schneider-electric.com)

## Related Documents

Title	Reference Number
ConneXium TCSEFEA Tofino Firewall User Manual	NHA15729
ConneXium TCSEFEA Tofino Firewall Installation Manual	NHA15734

The User Manual document contains the information you require to put the device into operation and configure it using the ConneXium Tofino Configurator software. The User Manual takes you step by step from the first startup operation through to the basic settings for operation in your environment.

The Installation Manual contains a device description, safety instructions, a description of the display, and the other information that you need to install the device.

## Key

The symbols used in this manual have the following meanings:

▶	Listing
□	Work step
■	Subheading

## Safety instructions

### ■ Important Information

**Notice:** Read these instructions carefully, and look at the equipment to become familiar with the device before trying to install, operate, or maintain it. The following special messages may appear throughout this documentation or on the equipment to warn of potential hazards or to call attention to information that clarifies or simplifies a procedure.



The addition of this symbol to a Danger or Warning safety label indicates that an electrical hazard exists, which will result in personal injury if the instructions are not followed.



This is the safety alert symbol. It is used to alert you to potential personal injury hazards. Obey all safety messages that follow this symbol to avoid possible injury or death.



## DANGER

**DANGER** indicates an imminently hazardous situation which, if not avoided, **will result in** death or serious injury.



## WARNING

**WARNING** indicates a potentially hazardous situation which, if not avoided, **can result in** death or serious injury.



## CAUTION

**CAUTION** indicates a potentially hazardous situation which, if not avoided, **can result in** minor or moderate injury.

**PLEASE NOTE:** Electrical equipment should be installed, operated, serviced, and maintained only by qualified personnel. No responsibility is assumed by Schneider Electric for any consequences arising out of the use of this material.  
© 2015 Schneider Electric. All Rights Reserved.

### ■ Usage

The device may only be employed for the purposes described in the catalog, technical description, and manuals.

### ■ Supply voltage

For safety reasons the devices have been designed to operate at low voltages. Thus, they may only be connected to the supply voltage connections and to the signal contact with SELV circuits with the voltage restrictions in accordance with IEC/EN 60950-1.

The supply voltage is electrically isolated from the housing.

Relevant for North America:

The device may only be connected to a supply voltage of class 2 that fulfills the requirements of the National Electrical Code, Table 11(b). If the voltage is being supplied redundantly (two different voltage sources), the combined supply voltages must fulfill the requirements of the National Electrical Code, Table 11(b).

Relevant for North America: For use in Class 2 circuits.

Only use copper wire/conductors of class 1, 140/167 °F (60/75 °C) or 167 °F (75 °C).

### ■ Shielding ground

The shielding ground of the connectable twisted pairs lines is connected to the front panel as a conductor.

## ■ Housing



### **DANGER**

#### **HAZARD OF ELECTRIC SHOCK**

Never insert sharp objects (small screwdrivers, wires, etc.) into the inside of the product.

**Failure to follow these instructions will result in death, serious injury, or equipment damage.**



### **WARNING**

#### **FIRE HAZARD**

Install the device in a fire protected enclosure according to EN 60950-1.

**Failure to follow these instructions can result in death, serious injury, or equipment damage.**



### **CAUTION**

#### **EQUIPMENT OVERHEATING**

When installing the device, make sure any ventilation slots remain free. Maintain a clearance of at least 10 cm (3.94 in).

**Failure to follow these instructions can result in injury or equipment damage.**

Only technicians authorized by the manufacturer are permitted to open the housing.

The device housing is grounded by means of the separate ground screw. (see table 1).

- Make sure that the electrical installation meets local or nationally applicable safety regulations.
- The device must be installed in the vertical position (see figure 2).

## ■ **Environment**

Operate the device at the specified ambient temperature (temperature of the ambient air at a distance of 2 inches (5 cm) from the device) and at the specified relative humidity exclusively.

- Install the device in a location where the climatic threshold values specified in the technical data will be observed.
- Use the device only in an environment within the pollution degree specified in the technical data.

## ■ **General safety instructions**

Electricity is used to operate this equipment. Comply with every detail of the safety requirements specified in the operating instructions regarding the voltages to apply (see [“Supply voltage” on page 6](#)).

- Only appropriately qualified personnel should work on this device or in its vicinity. These personnel must be thoroughly familiar with the hazard messages and maintenance procedures in accordance with this operating manual.
- The proper and safe operation of this device depends on proper handling during transport, proper storage and assembly, and conscientious operation and maintenance procedures.
- Never start operation with damaged components.
- Only use the devices in accordance with this manual. In particular, observe the hazard messages and safety-related information.
- Any work that may be required on the electrical installation may only be carried out by personnel trained for this purpose.

## ■ **National and international safety regulations**

- Make sure that the electrical installation meets local or nationally applicable safety regulations.

## ■ **CE marking**

The labeled devices comply with the regulations contained in the following European directive(s):

2011/65/EU (RoHS)

Directive of the European Parliament and of the Council on the restriction of the use of certain hazardous substances in electrical and electronic equipment.

2004/108/EC (EMC)

Directive of the European Parliament and the council for standardizing the regulations of member states with regard to electromagnetic compatibility.

In accordance with the above-named EU directive(s), the EU conformity declaration will be at the disposal of the relevant authorities at the following address:



Schneider Electric  
35 rue Joseph Monier  
CS30323  
92506 Rueil-Malmaison-France

The product can be used in the industrial sector.

- ▶ Interference immunity: EN 61000-6-2:2005
- ▶ Emitted interference: EN 55022:2010

#### ■ **FCC note**

This device complies with part 15 of the FCC rules. Operation is subject to the following two conditions: (1) this device may not cause harmful interference; (2) this device must accept any interference received, including interference that may cause undesired operation.

Appropriate testing has established that this device fulfills the requirements of a class A digital device in line with part 15 of the FCC regulations.

These requirements are designed to provide sufficient protection against interference when the device is being used in a business environment. The device creates and uses high frequencies and can also radiate high frequencies, and if it is not installed and used in accordance with this operating manual, it can cause radio transmission interference. The use of this device in a living area can also cause interference, and in this case the user is obliged to cover the costs of removing the interference.

# 1 Description

## 1.1 General device description

The Tofino Firewall TCSEFEA helps provide for the security of communication within production networks.

This device works in one of 3 operating modes:

- ▶ Unconfigured mode
- ▶ Test mode
- ▶ Operational mode

The ConneXium Tofino Firewall is used everywhere that security-sensitive network cells require a connection from the internal network into an external network. The ConneXium Tofino Firewall is the link between the internal network and the external network from which unauthorized accesses are to be expected. In its function as a link, the ConneXium Tofino Firewall helps protect the internal network from undesired data traffic along the connection to the external network.

Typical uses are:

- ▶ Helping protect individual production cells in a flat company network.
- ▶ Helping protect individual production cells in a routed company network.
- ▶ Helping provide protected service access.
- ▶ Dividing control networks into security areas.
- ▶ Helping secure the connection for partner networks.
- ▶ Helping protect wireless networks.
- ▶ Separating integrated security systems.

The device is designed for the special requirements of industrial automation. It meets the relevant industry standards, provides high operational reliability, even under extreme conditions, and also long-term reliability and flexibility. The device operates without a fan and has a redundant voltage supply. The device is quickly mounted by snapping it onto a DIN rail, which also automatically contacts the function ground.

The device supports the following security functions:

- ▶ Stateful Firewall (FW)
- ▶ Denial of Service Traffic Limiter
- ▶ Security Alarm and Event Logging
- ▶ Modbus TCP Enforcer

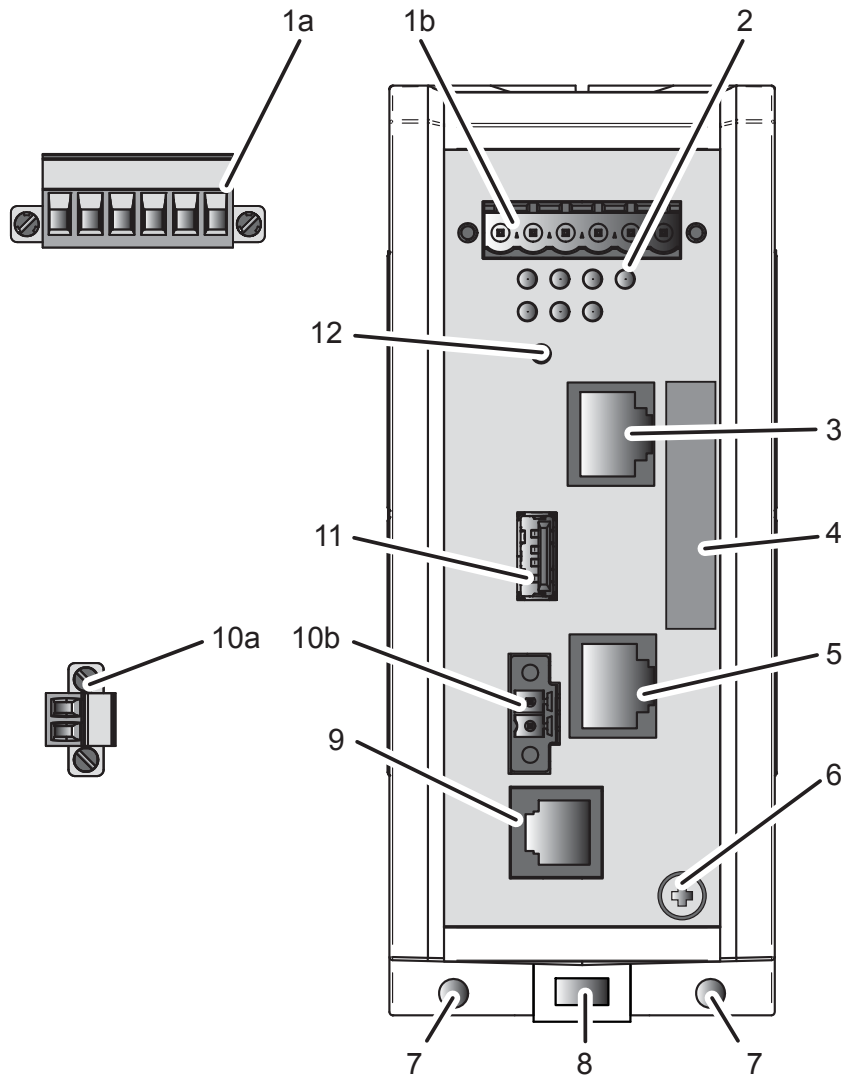

1a	6 pin, screwable terminal block for redundant supply voltage and signal contact	
1b	Terminal block connection	
2	LED display elements	
3	Ethernet port 1 INTERNAL	RJ45 socket for 10/100 Mbit/s twisted pair connections
4	Tofino ID	
5	Ethernet port 2 EXTERNAL	RJ45 socket for 10/100 Mbit/s twisted pair connections
6	Grounding screw	
7	Hole for mounting using a wall mounting plate	
8	Locking gate for removing the device	
9	V.24 interface The V.24 interface is <b>not</b> active in this version of the firmware.	
10a	2 pin, screwable terminal block for digital input	
10b	Terminal block connection	
11	USB interface	
12	Save/Load/Reset button	

Table 1: Front view TCSEFEA23F3F22

## 2 Assembly and start-up

### 2.1 Safety instructions

#### ■ Staff qualification requirements

Only appropriately qualified staff should work on or near this equipment. Such staff must be thoroughly acquainted with all the hazard messages and maintenance measures contained in these operating instructions. The proper and safe operation of this equipment assumes proper transport, appropriate storage and assembly, and careful operation and maintenance.

Qualified staff are persons familiar with setting up, assembling, installation, starting up, and operating this product, and who have appropriate qualifications to cover their activities, such as:

- ▶ knowledge of how to switch circuits and equipment/systems on and off, ground them, and identify them in accordance with current safety standards
- ▶ training or instruction in accordance with current safety standards of using and maintaining appropriate safety equipment
- ▶ first aid training

#### ■ Recycling note

After usage, this product must be disposed of properly as electronic waste, in accordance with the current disposal regulations of your county, state and country.

### 2.2 Installing the device

#### **WARNING**

##### **FIRE HAZARD**

Install the device in a fire protected enclosure according to EN 60950-1.

**Failure to follow these instructions can result in death, serious injury, or equipment damage.**

Before installing and starting up the device, note the safety instructions (see page 5 “[Safety instructions](#)” onwards).

## 2.2.1 Overview of installation

Two or more devices configured with the same IP address can cause unpredictable operation of your network.

### **WARNING**

#### **UNINTENDED EQUIPMENT OPERATION**

Establish and maintain a process for assigning unique IP addresses to all devices on the network.

**Failure to follow these instructions can result in death, serious injury, or equipment damage.**

The devices have been developed for practical application in a harsh industrial environment.

On delivery, the device is ready for operation.

The following steps should be performed to install and configure a ConneXium Tofino Firewall product:

- ▶ Unpacking and checking
- ▶ Connect the terminal block for voltage supply and signal contact and connect the supply voltage
- ▶ Install the terminal block, start-up procedure
- ▶ Install the device on the DIN rail, grounding
- ▶ Connect the data lines

## 2.2.2 Unpacking and checking

- Check that the contents of the package are complete ([see on page 30 "Scope of delivery"](#)).
- Check the individual parts for transport damage.

## 2.2.3 Terminal block for supply voltage and signal contact

The supply voltage and the signal contact are connected via a 6-pin terminal block with a snap lock.

## ■ Supply voltage

# ⚠ DANGER

### HAZARD OF ELECTRIC SHOCK OR BURN

When the module is operated with direct plug-in power units, use only:

- SELV supply units that comply with IEC 60950/EN 60950 and
- (in USA and Canada) Class 2 power units that comply with applicable national or regional electrical codes

Connect the ground wire to the PE terminal (where applicable) before you establish any further connections. When you remove connections, disconnect the ground wire last.

**Failure to follow these instructions will result in death, serious injury, or equipment damage.**

**Note:** The torque for tightening the supply voltage terminal block on the device is 4.5 lb-in (0.51 Nm).

The torque for tightening the terminal block on the digital input of the device is 3 lb-in (0.34 Nm).

Redundant power supplies can be used. Both inputs are uncoupled. There is no distributed load. With redundant supply, the power supply unit supplies the device only with the higher output voltage. The supply voltage is electrically isolated from the housing.

For the supply voltage, you can connect either AC or DC voltage.

**Note:** With non-redundant supply of the main voltage, the device reports a loss of power. You can avert this message by supplying the voltage over the two inputs or changing the configuration in the management.

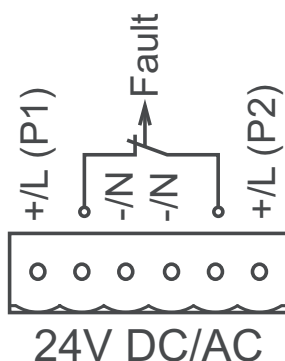

Figure 1: Pin assignment of the 6-pin terminal block

## ■ Signal contacts

The potential-free signal contact (relay contact, closed circuit) reports a physical link interruption on one or both network connections.

### 2.2.4 Connecting the terminal block, start-up procedure

- Pull the terminal block off the device and connect the voltage supply lines and the signal lines.

## ■ Startup procedure

- Mount the terminal block for the voltage supply and signal contact on the front of the device by snapping the lock into place.

Connecting the voltage supply via the terminal block starts the operation of the device.

### 2.2.5 Wiring the digital input (optional)

	Pin	Signal, terminal	Function
	1	DI (+)	Signal input
	2	DI (-)	Reference potential

Table 2: Pin assignment: 2 pin, screwable terminal block (on the left), connection to the device (to the right)

- Remove the power connector from the device.
- Connect the wires according to the pin assignment on the device with the clamps.
- Fasten the wires connected by tightening the terminal screws.

### 2.2.6 Installing the device on the DIN rail, grounding

- Mount the device on a 35 mm DIN rail in accordance with DIN EN 60175.
- Attach the upper snap-in guide of the device into the DIN rail and press the device down against the DIN rail until it snaps into place.

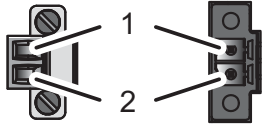
**Note:** The shielding ground of the connectable industrial twisted pair lines is connected to the front panel as a conductor.

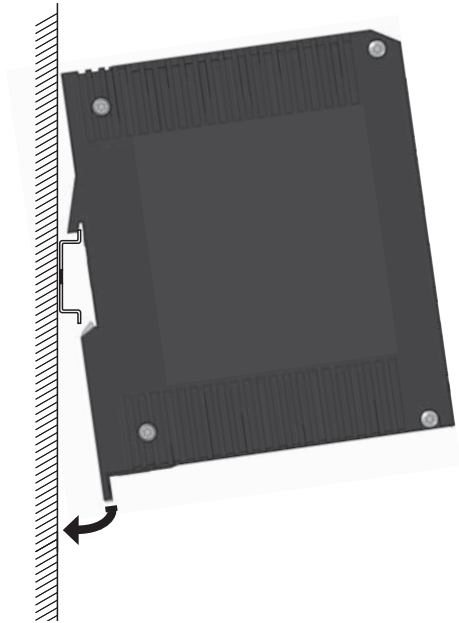

Figure 2: Mounting on the DIN rail

### ■ **Grounding**

The device housing is grounded by means of the separate ground screw. (see table 1).

## 2.2.7 Connecting the data lines

### ■ **10/100 Mbit/s twisted pair connection**

These connections are RJ45 sockets.

10/100 Mbit/s TP ports enable the connection of terminal devices or independent network segments according to the IEEE 802.3 10BASE-T/100BASE-TX standard.

These ports support:

- ▶ Autonegotiation
- ▶ Autopolarity
- ▶ Autocrossing (if autonegotiation is activated)
- ▶ 100 Mbit/s half-duplex mode, 100 Mbit/s full duplex mode
- ▶ 10 Mbit/s half-duplex mode, 10 Mbit/s full duplex mode

Delivery state: autonegotiation activated

The socket housing is electrically connected to the front panel.



Figure	Pin	Function
	1+2	One line pair: receiver path
	3+6	One line pair: sender path
	4,5,7,8	Not used

Table 3: Pin assignment of a TP/TX interface in MDI-X mode, RJ45 socket

## 2.2.8 Connection to the network

- Connect the device via the INTERNAL port to the internal network or the local computer that you want to help protect.
- Connect the device via the EXTERNAL port to the external network, such as the Internet. This network is used to set up the connections to the external device or external network.

## 2.3 Display elements

After the operating voltage is set up, the software starts and initializes itself. Afterwards, the device performs a self-test.

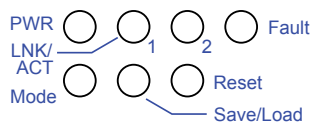

### 2.3.1 Device state

These LEDs provide information about conditions which affect the operation of the whole device.

LED	Display	Color	Activity	Meaning
PWR	Supply voltage	—	None	Supply voltage is too low
		Yellow	Lights up	Supply voltage 1 <b>or</b> 2 is on
		Green	Lights up	Supply voltages 1 <b>and</b> 2 are on
LNK/ ACT 1 LNK/ ACT 2	Link status	—	None	Device detects an invalid or missing link
		Green	Lights up	Device detects a valid link
			Flashes 3 times a period	Port is switched off
		Yellow	Flashing	Device is transmitting and/or receiving data

LED	Display	Color	Activity	Meaning
Fault	System and USB save/load errors	Red	None	The signal contact is closed - it is <b>not</b> reporting any detected errors.
			Very short flashing in cycles of 0.5 s	A detected USB load or save error occurred.
Mode	Operating mode	Green	None	The device is in unconfigured mode.
			Lights up	The device is in operational mode.
			Long flashing	The device is in test mode.
Save/Load	Preparation Saving process	Green	Lights up (5 s)	The saving of the device diagnostic or log files to the USB storage device is about to begin.
	Preparation Loading process	Yellow	Lights up (5 s)	The load of the configuration files from the USB storage device is about to begin.
Reset	Preparation Reset process	Yellow	Lights up (5 s)	The reset of the device to the factory defaults is about to begin.
Mode Reset	Execution Saving process	Green	Flashing alternately in left to right sequence	The device saves the diagnostic files or log files on the USB device.
	Execution Loading process	Yellow	Flashing alternately in right to left sequence	The device loads the configuration files from the USB device.
Mode Save/Load Reset Fault	Execution Reset process		Flashing simultaneously	The reset of the device to the factory defaults is in progress.

## 2.4 Controls

The TCSEFEA has a Save/Load/Reset (SLR) button ([see table 1](#)).

### ■ Save/Load/Reset button SLR

The SLR button has the following functions:

- ▶ Saving diagnostic files and log files on the USB storage device
  - ▶ Loading configuration files from the USB storage device
  - ▶ Factory resetting the device
- To perform the functions, press the SLR button. The number of button presses controls which function is carried out. Check your selection by looking at the LEDs.

Button presses	Chosen function	LED behavior
1	Saving diagnostic files and log files on the USB storage device	The Save/Load LED will illuminate in green. After a few seconds the Mode, Save/Load, and Reset LEDs will flash in green in a left to right sequence to indicate the USB Save is in progress
2	Loading configuration files from the USB storage device	The Save/Load LED will illuminate in yellow. After a few seconds the Mode, Save/Load, and Reset LEDs will flash in yellow in a right to left sequence to indicate the USB Load is in progress.
3	Factory resetting the device	The following LEDs flash simultaneously: Mode, Save/Load, Reset, Fault.
4	Canceling prior button presses	—

## 2.5 Basic set-up

Use the Tofino Configurator software to create the configuration data that is then either transferred over the network using an encrypted connection or transferred in encrypted form on a USB storage device.

You do not require an IP address to install the device.

You will find further information in the ConneXium TCSEFEA User Manual.

### ■ Default settings

- ▶ Twisted pair ports: autonegotiation
- ▶ Device mode:  
Unconfigured mode and passing all traffic

### 2.5.1 USB interface

The USB port has an interface for the local connection of a USB storage device. It is used for saving/loading the configuration, transferring event logs, and updating the firmware and licenses.

Contact number	Signal name
1	VCC
2	- Data
3	+ Data
4	Ground

**Note:** The following version 2.0 USB storage devices are known to work: Kingston Data Traveler, SanDisk Cruzer, Sony Microvault, Lexar, and Schneider TCSEAM0100.

## ■ **USB Save**

Perform a USB Save on the TCSEFEA to save event log and diagnostic information from the hardware to a USB storage device.

- Power on the TCSEFEA for at least one minute.
- Insert the USB storage device into the USB port.
- Press the Save/Load/Reset button once.

The Save/Load LED will illuminate in green. After a few seconds the Mode, Save/Load, and Reset LEDs will flash in green in a left to right sequence to indicate the USB Save is in progress.

- When the flashing sequence stops, remove the USB storage device. If the save was successful the LEDs will revert to the state they were in prior to the save action.

## ■ **USB Load**

Perform a USB Load to transfer configuration files and firmware updates stored on a USB storage device to the TCSEFEA.

- Power on the TCSEFEA for at least one minute.
- Insert the USB storage device containing the prepared files into the USB port.
- Press the Save/Load/Reset button twice.

The Save/Load LED will illuminate in yellow. After a few seconds the Mode, Save/Load, and Reset LEDs will flash in yellow in a right to left sequence to indicate the USB Load is in progress.

- When the flashing sequence stops, remove the USB storage device. If the load was successful the Fault LED will be off.

## ■ **Fault LED**

The Fault LED flashes during the USB save and load sequences to convey specific messages. See the following table to interpret this activity.

No. of flashes	During save sequence	During load sequence
1	---	The USB port is disabled. In the ConneXium Tofino Configurator, check the Communications setting on the TCSEFEA General page. The method of communication should be "USB Only" or "Both USB and Network".
2	No USB storage device is connected to the USB connection, or the file system of the storage device is not formatted as FAT or FAT32.	No USB storage device is connected to the USB connection, or the file system of the storage device is not formatted as FAT or FAT32.
3	The device was unable to create any diagnostic files. Please contact technical support.	The files on the USB storage device are invalid.

Table 4: *Fault LED diagnostics for USB Save and Load*

No. of flashes	During save sequence	During load sequence
4	The device was unable to encrypt the diagnostic files. Please contact technical support.	The device was unable to decrypt the configuration files. The files were possibly damaged during the copying operation. Repeat the copying operation. If the condition persists, contact technical support.
5	The device was unable to copy the diagnostic files to the USB storage device. It is possible that the storage device is full.	The device was unable to load the files. It is possible that the files were damaged during the copying operation. Repeat the copying operation. If the condition persists, contact technical support.
6	The device was unable to deactivate the USB connection. Please contact technical support.	The device was unable to deactivate the USB connection. Please contact technical support.
7	The file system of the device does not have enough storage capacity to save the files temporarily before they are copied to the USB storage device. Please contact technical support.	---

Table 4: Fault LED diagnostics for USB Save and Load

## 2.5.2 V.24 interface

The V.24 interface is **not** active in this version of the firmware.

## 2.6 Configuration

Configure the device using the Schneider Electric ConneXium Tofino Configurator. Configurations can be applied either over the network or via the encrypted USB storage device.

You will find further information on both methods of configuration in the ConneXium TCSEFEA User Manual.

## 2.7 Operating Modes

This device works in one of 3 operating modes:

- ▶ Unconfigured mode
- ▶ Test mode
- ▶ Operational mode

Mode	Description	LED	Color	Activity
Unconfigured mode	This is the mode of the device on delivery. All security functionality is turned off and the device is listening for initialization commands. The device has been preconfigured so that all Ethernet traffic in both directions is permitted. This is so that the installation of the device will not interrupt or impact process operations.	Mode	---	None
Test Mode	In Test mode the device does not impact network traffic in any way, but generates alarm messages for any traffic that would have been blocked if the device was in Operational mode. This is used to test that the device is correctly configured before it is used to filter control system traffic.	Mode	Green	Flashing
Operational Mode	In Operational mode the device is fully operational, processes all traffic, and will block any messages not specifically permitted by firewall rules.	Mode	Green	Solid

Table 5: Operating modes

## 2.8 Maintenance

Depending on the degree of pollution in the operating environment, check at regular intervals that the ventilation slots in the device are not obstructed. Operate this device according to the specifications (see [“Technical data”](#)).

## 2.9 Disassembly

### ■ Removing the device from the DIN rail

- In order to remove the device from the DIN rail, insert the screwdriver horizontally under the chassis in the locking slide, pull this down – without tilting the screwdriver – and lift the device upwards.

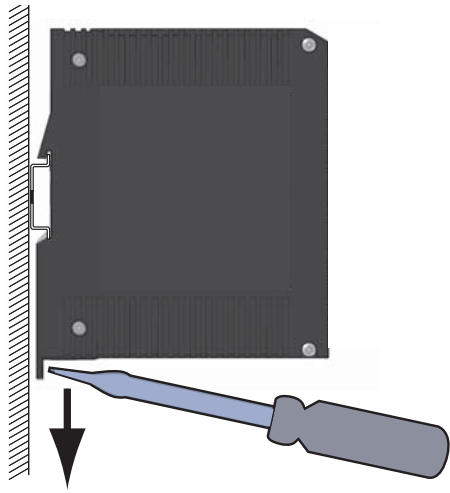

*Figure 3: Removing the device from the DIN rail*

### 3 Technical data

#### ■ General technical data

Dimensions W × H × D	See "Dimension drawings" on page 26.	
Weight	23.23 oz (660 g)	
Power supply	<ul style="list-style-type: none"> <li>▶ 2 voltage inputs for redundant power supply</li> <li>▶ Safety extra-low voltage (SELV), redundant inputs disconnected</li> </ul>	
Nominal voltage AC	24 V, Class 2	
Voltage range AC incl. maximum tolerances	18 V ... 30 V, Class 2	
Rated voltage range DC	12 V ... 48 V, Class 2	
Voltage range DC incl. maximum tolerances	9.6 V ... 60 V, Class 2	
Connection type	6 pin, screwable terminal block for redundant supply voltage and signal contact	
Power failure bypass	> 10 ms at 20.4 V DC or AC > 2 ms at 10.2 V DC	
Overload current protection at input	Non-replaceable fuse	
Back-up fuse for each voltage input when supply is via 2 inputs	Nominal value at 48 V	1 A
	Nominal value at 24 V	1 A ... 2 A
	Nominal value at 12 V	1 A ... 2.5 A
	Characteristic:	slow blow
Back-up fuse when using 1 voltage input <sup>a</sup>	Nominal value at 48 V	1 A ... 2 A
	Nominal value at 24 V	1 A ... 4 A
	Nominal value at 12 V	1 A ... 5 A
	Characteristic:	slow blow
Peak inrush current	< 14 A	
Climatic conditions during operation	Ambient air temperature <sup>b</sup>	-40 °F ... +158 °F (-40 °C ... +70 °C)
	Maximum inner temperature of device (guideline)	194 °F (90 °C)
	Humidity	10 % ... 95 % (non-condensing)
	Air pressure	minimum 795 hPa (+9842 ft; +2000 m) maximum 1060 hPa (-1312 ft; -400 m)



Climatic conditions during storage	Ambient air temperature <sup>c</sup>	-40 °F ... +185 °F (-40 °C ... +85 °C)
	Humidity	10 % ... 95 % (non-condensing)
	Air pressure	minimum 700 hPa (+9842 ft; +3000 m) maximum 1060 hPa (-1312 ft; -400 m)
Signal contact FAULT	Switching current	max. 1 A, SELV
	Switching voltage	max. 60 V DC, SELV Relevant for North America: max. 30 V DC, Class 2, resistive load
Pollution degree		2
Protection classes	Laser protection	Class 1 in compliance with IEC 60825-1
	Degree of protection	IP20

- a. As an alternative to the back-up fuse is possible:  
Voltage supply according to Class 2 or EN 60950-1 Limited Power Source
- b. Temperature of the ambient air at a distance of 2 inches (5 cm) from the device
- c. Temperature of the ambient air at a distance of 2 inches (5 cm) from the device

## ■ Digital input

Maximum permitted input voltage range	-32 V DC ... +32 V DC
Nominal input voltage	+24 V DC
Input voltage, low level, status "0"	-0.3 V DC ... +5.0 V DC
Input voltage, high level, status "1"	+11 V DC ... +30 V DC
Maximum input current at 24 V input voltage	15 mA
Input characteristic according to IEC 61131-2 (current-consuming)	Type 3

**Note:** For the pin assignment see ["Wiring the digital input \(optional\)"](#) on page 15.

## ■ Dimension drawings

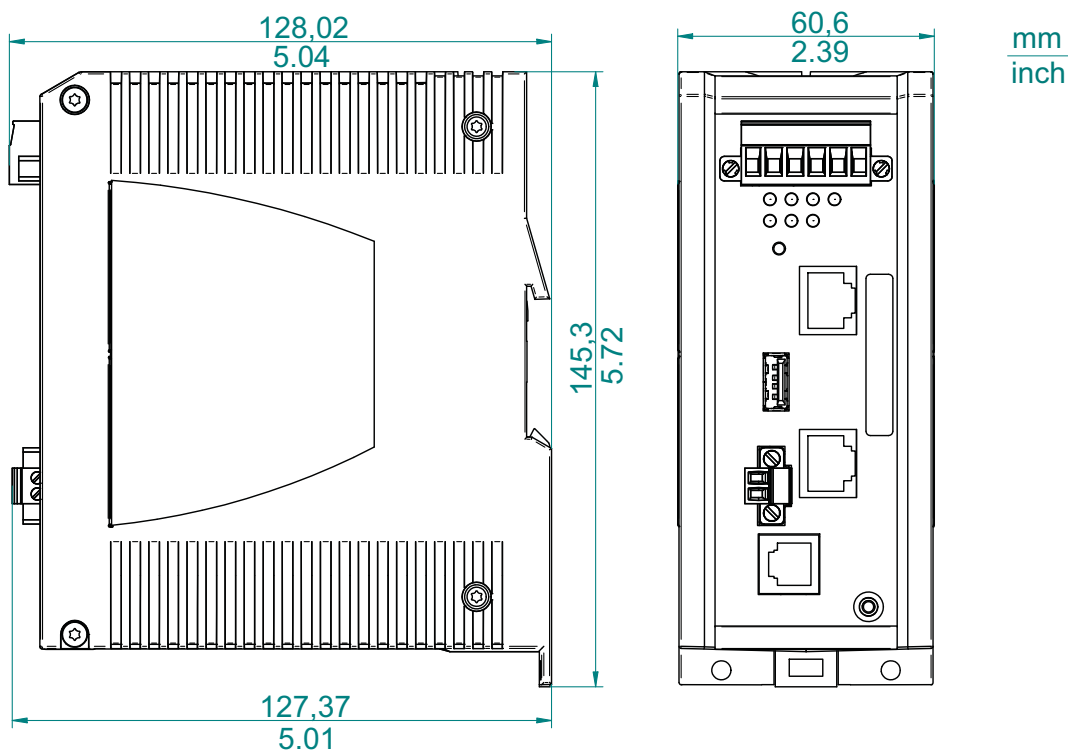

Figure 4: Dimensions

## ■ EMC and immunity

<b>Stability</b>		<b>Standard applications</b>	<b>Navy applications</b>
IEC 60068-2-6, test Fc	Vibration	5 Hz ... 8.4 Hz with 0.14 in. (3.5 mm) amplitude	2 Hz ... 13.2 Hz with 0.04 in. (1 mm) amplitude
		—	—
		8.4 Hz ... 150 Hz with 1 g	13.2 Hz ... 100 Hz with 0.7 g
		—	—
		—	—
IEC 60068-2-27, test Ea	Shock	0.53 oz (15 g) at 11 ms	
<b>EMC interference emission</b>		<b>Standard applications</b>	<b>Navy applications</b>
<b>Radiated emission</b>			
EN 55022		Class A	Class A
GL Guidelines		—	EMC 1
FCC 47 CFR Part 15		Class A	Class A
EN 61000-6-4		Fulfilled	Fulfilled
<b>Conducted emission</b>			
EN 55022	AC and DC supply connections	Class A	Class A
GL Guidelines	AC and DC supply connections	—	EMC 1
FCC 47 CFR Part 15	AC and DC supply connections	Class A	Class A
EN 61000-6-4	AC and DC supply connections	Fulfilled	Fulfilled
EN 55022	Telecommunication connections	Class A	Class A
EN 61000-6-4	Telecommunication connections	Fulfilled	Fulfilled
<b>EMC interference immunity</b>		<b>Standard applications</b>	<b>Navy applications</b>
<b>Electrostatic discharge</b>			
EN 61000-4-2	Contact discharge	± 4 kV	± 6 kV
IEEE C37.90.3			

<b>EMC interference immunity</b>		<b>Standard applications</b>	<b>Navy applications</b>
EN 61000-4-2 IEEE C37.90.3	Air discharge	± 8 kV	± 8 kV
<b>Electromagnetic field</b>			
EN 61000-4-3 IEEE 1613	80 MHz ... 3000 MHz 80 MHz ... 1000 MHz	10 V/m —	10 V/m —
<b>Fast transients (burst)</b>			
EN 61000-4-4 IEEE C37.90.1	AC/DC supply connection	± 2 kV	± 2 kV
EN 61000-4-4 IEEE C37.90.1	Data line	± 4 kV	± 4 kV
<b>Voltage surges - DC supply connection</b>			
EN 61000-4-5 IEEE 1613	line/ground line/ground	± 2 kV —	± 2 kV —
EN 61000-4-5	line/line	± 1 kV	± 1 kV
<b>Voltage surges - data line</b>			
EN 61000-4-5	line/ground	± 1 kV	± 1 kV
<b>Conducted disturbances</b>			
EN 61000-4-6	150 kHz ... 80 MHz	10 V	10 V

<b>EMC interference immunity</b>		<b>Standard applications</b>	<b>Navy applications</b>
<b>Damped oscillation - AC/DC supply connection</b>			
EN 61000-4-12	line/ground	—	—
IEEE C37.90.1			
EN 61000-4-12	line/line	—	—
IEEE C37.90.1			
<b>Damped oscillation - data line</b>			
EN 61000-4-12	line/ground	—	—
IEEE C37.90.1			
EN 61000-4-12	line/line	—	—
<b>Pulse magnetic fields</b>			
EN 61000-4-9		—	—

## ■ Network range

### TP port

Length of a twisted pair segment	max. 100 m
----------------------------------	------------

Table 6: TP port 10BASE-T / 100BASE-TX

## ■ Power consumption/power output

Device variant	Maximum power consumption	Power output
...TX/TX	5 W	17 Btu (IT)/h

## ■ Interfaces

TCSEFEA	two 10/100 Mbit/s twisted pair (TP/TX) ports with RJ45 V.24 port: Not active in this version of firmware.. terminal block, 6-pin: signal contact, max. 1 A, 24 V and voltage supply terminal block, 2-pin: digital input USB interface: TCSEAM0100-Adapter
---------	---

## ■ Scope of delivery

Number	Article
1 ×	Device
1 ×	6 pin, screwable terminal block for redundant supply voltage and signal contact
1 ×	2 pin, screwable terminal block for digital input
1 ×	Installation user manual
1 ×	Read Me document with attached licence activation key

## ■ Product/product code/product description

Product	Product code	Product description
TCSEFEA with 2 ports, Statefull Firewall, Event Logger, NetConnect and Modbus TCP Enforcer	TCSEFEA23F3F22	2 managed 10/100 TX
Accessories	see note below	Version 2.0 USB storage device

**Note:** The following version 2.0 USB storage devices are known to work: Kingston Data Traveler, SanDisk Cruzer, Sony Microvault, Lexar, and Schneider ACA 21-USB.

## ■ Accessories

Other accessories	Order number
ConneXium Tofino OPC LSM	TCSEFM0000
ConneXium Tofino EIP LSM	TCSEFM0001

## ■ Underlying norms and standards

Name	
EN 61000-6-2	Electromagnetic compatibility (EMC) – Part 6-2: Generic standards – Immunity for industrial environments
EN 55022	Information technology equipment – Radio disturbance characteristics – Limits and methods of measurement
EN 60950-1	Information technology equipment – Safety – Part 1: General requirements
EN 61131-2	Programmable logic controllers
EN 50121-4	Railway applications – EMC – Emission and immunity of the signalling and telecommunications apparatus (Rail Trackside)
FCC 47 CFR Part 15	Code of Federal Regulations
German Lloyd	Classification and Construction Guidelines VI-7-3 Part 1 Ed.2003
UL 508	Safety for Industrial Control Equipment
EN 60079-15	Explosive atmospheres – Part 15: Equipment protection by type of protection “n”
EN 50155	Declaration (Railways)
IEC/EN 61850-3	Communication networks and systems in substations – Part 3: General requirements
IEEE 1613	IEEE Standard Environmental and Testing Requirements for Communication Networking Devices in Electric Power Substations

*Table 7: List of norms and standards*

IEEE 802.1AB	Topology Discovery (LLDP)
IEEE 802.3-2002	Ethernet
IEEE 802.3ac	VLAN Tagging

*Table 8: List of IEEE norms*

The device has an approval based on a specific standard or de facto standard only if the approval indicator appears on the housing.