

# GP-4100 Series Color Model

## Hardware Manual

GP4100-CL-MM01-EN-PDF\_07  
09/2020

---

The information provided in this documentation contains general descriptions and/or technical characteristics of the performance of the products contained herein. This documentation is not intended as a substitute for and is not to be used for determining suitability or reliability of these products for specific user applications. It is the duty of any such user or integrator to perform the appropriate and complete risk analysis, evaluation and testing of the products with respect to the relevant specific application or use thereof. Neither Schneider Electric nor any of its affiliates or subsidiaries (hereinafter, referred to as Schneider Electric) shall be responsible or liable for misuse of the information that is contained herein. If you have any suggestions for improvements or amendments or have found errors in this publication, please notify us.

You agree not to reproduce, other than for your own personal, noncommercial use, all or part of this document on any medium whatsoever without permission of Schneider Electric, given in writing. You also agree not to establish any hypertext links to this document or its content. Schneider Electric does not grant any right or license for the personal and noncommercial use of the document or its content, except for a non-exclusive license to consult it on an "as is" basis, at your own risk. All other rights are reserved.

All pertinent state, regional, and local safety regulations must be observed when installing and using this product. For reasons of safety and to help ensure compliance with documented system data, only the manufacturer should perform repairs to components.

When devices are used for applications with technical safety requirements, the relevant instructions must be followed.

Failure to use Schneider Electric software or approved software with our hardware products may result in injury, harm, or improper operating results.

Failure to observe this information can result in injury or equipment damage.

Copyright © 2020 Schneider Electric Japan Holdings Ltd. All rights reserved.

# Table of Contents



	<b>Safety Information</b> .....	5
	<b>About the Book</b> .....	7
<b>Chapter 1</b>	<b>Overview</b> .....	11
	Model Numbers .....	12
	Package Contents .....	13
	Certifications and Standards .....	14
	Federal Communication Commission Radio Frequency Interference Statement - For USA .....	16
	Hazardous Location Installation - For USA and Canada .....	17
<b>Chapter 2</b>	<b>Device Connectivity</b> .....	21
	System Design .....	22
	Accessories .....	23
<b>Chapter 3</b>	<b>Parts Identification and Functions</b> .....	25
	GP-4100 Series Color Model .....	26
	LED Indications .....	27
<b>Chapter 4</b>	<b>Specifications</b> .....	29
4.1	General Specifications .....	30
	Electrical Specifications .....	31
	Environmental Specifications .....	32
	Structural Specifications .....	33
4.2	Functional Specifications .....	35
	Display Specifications .....	36
	Memory, Clock, Touch Panel .....	37
4.3	Interface Specifications .....	38
	Interface Specifications .....	39
	Interface Connection .....	40
	Serial Interface .....	41
<b>Chapter 5</b>	<b>Dimensions</b> .....	45
	External Dimensions .....	46
	Dimensions with Installation Fasteners Attached .....	47
	Installation Fastener Dimensions .....	48
<b>Chapter 6</b>	<b>Installation and Wiring</b> .....	49
6.1	Installation .....	50
	Introduction .....	51
	Installation Requirements .....	52
	Panel Cutout Dimensions .....	54
	Panel Mounting Procedure A .....	55
	Panel Mounting Procedure B .....	57
6.2	Wiring Principles .....	60
	Connecting the DC Power Cord .....	61
	Connecting the Power Supply .....	63
	Grounding .....	65

---

6.3	USB Clamp	66
	USB Clamp Type A (1 port)	67
	USB Clamp mini-B (1 port)	70
6.4	RTC Battery Set	72
	Introduction	73
	Attaching the RTC Battery Set	74
<b>Chapter 7</b>	<b>Maintenance</b>	<b>75</b>
	Regular Cleaning	76
	Periodic Check Points	77
	Replacing the Installation Gasket	78
	Replacing the Battery in the RTC Battery Set	79
	Replacing the Backlight	81
	After-sales Service	82

# Safety Information



## Important Information

### NOTICE

Read these instructions carefully, and look at the equipment to become familiar with the device before trying to install, operate, service, or maintain it. The following special messages may appear throughout this documentation or on the equipment to warn of potential hazards or to call attention to information that clarifies or simplifies a procedure.



The addition of this symbol to a “Danger” or “Warning” safety label indicates that an electrical hazard exists which will result in personal injury if the instructions are not followed.



This is the safety alert symbol. It is used to alert you to potential personal injury hazards. Obey all safety messages that follow this symbol to avoid possible injury or death.

## **DANGER**

**DANGER** indicates a hazardous situation which, if not avoided, **will result in** death or serious injury.

## **WARNING**

**WARNING** indicates a hazardous situation which, if not avoided, **could result in** death or serious injury.

## **CAUTION**

**CAUTION** indicates a hazardous situation which, if not avoided, **could result in** minor or moderate injury.

## **NOTICE**

**NOTICE** is used to address practices not related to physical injury.

### PLEASE NOTE

Electrical equipment should be installed, operated, serviced, and maintained only by qualified personnel. No responsibility is assumed by Schneider Electric for any consequences arising out of the use of this material.

A qualified person is one who has skills and knowledge related to the construction and operation of electrical equipment and its installation, and has received safety training to recognize and avoid the hazards involved.



---

# About the Book

---



## At a Glance

### Document Scope

This manual describes how to use this product.

### Validity Note

This documentation is valid for this product.

The technical characteristics of the device(s) described in the present manual also appear online at [www.pro-face.com](http://www.pro-face.com).

The characteristics presented in the present document should be the same as those that appear online. In line with our policy of constant improvement we may revise content over time to improve clarity and accuracy. In the event that you see a difference between the document and online information, use the online information as your reference.

### Registered Trademarks

Microsoft and Windows are registered trademarks of Microsoft Corporation in the United States and/or other countries.

Product names used in this manual may be the registered trademarks owned by the respective proprietors.

### Related Documents

You can download the manuals related to this product, such as the software manual, from our support site at <http://www.pro-face.com/trans/en/manual/1001.html>.

### Product Related Information

If the equipment is used in a manner not specified by the manufacturer, the protection provided by the equipment may be impaired.

## DANGER

### HAZARD OF ELECTRIC SHOCK, EXPLOSION, OR ARC FLASH

- Remove all power from the device before removing any covers or elements of the system, and prior to installing or removing any accessories, hardware, or cables.
- Unplug the power cable from both this product and the power supply.
- Always use a properly rated voltage sensing device to confirm power is off.
- Replace and secure all covers or elements of the system before applying power to this product.
- Use only the specified voltage when operating this product. This product is designed to use 12 to 24 Vdc. Always check whether your device is DC powered before applying power.

**Failure to follow these instructions will result in death or serious injury.**

Critical alarm indicators and system functions require independent and redundant protection hardware and/or mechanical interlocks.

When you cycle power, wait at least 10 seconds after it has been turned off. If this product is restarted too quickly, it may not operate correctly.

---

In the event the screen cannot be properly read, for example, if the backlight is not functioning, it may be difficult or impossible to identify a function. Functions that may present a hazard if not immediately executed, such as a fuel shut-off, must be provided independently of this product. The machine's control system design must take into account the possibility of the backlight no longer functioning and the operator being unable to control the machine or making mistakes in the control of the machine.

 **WARNING**

**LOSS OF CONTROL**

- The designer of any control scheme must consider the potential failure modes of control paths and, for certain critical control functions, provide a means to achieve a safe state during and after a path failure. Examples of critical control functions are emergency stop and overtravel stop, power outage and restart.
- Separate or redundant control paths must be provided for critical control functions.
- System control paths may include communication links. Consideration must be given to the implications of unanticipated transmission delays or failures of the link.
- Observe all accident prevention regulations and local safety guidelines.
- Each implementation of this product must be individually and thoroughly tested for proper operation before being placed into service.
- The machine control system design must take into account the possibility of the backlight no longer functioning and the operator being unable to control the machine, or making errors in the control of the machine.

**Failure to follow these instructions can result in death, serious injury, or equipment damage.**

For additional information, refer to NEMA ICS 1.1 (latest edition), "Safety Guidelines for the Application, Installation, and Maintenance of Solid State Control" and to NEMA ICS 7.1 (latest edition), "Safety Standards for Construction and Guide for Selection, Installation and Operation of Adjustable-Speed Drive Systems" or their equivalent governing your particular location.

 **WARNING**

**UNINTENDED EQUIPMENT OPERATION**

- The application of this product requires expertise in the design and programming of control systems. Only persons with such expertise should be allowed to program, install, alter, and apply this product.
- Follow all local and national safety standards.

**Failure to follow these instructions can result in death, serious injury, or equipment damage.**

 **WARNING**

**UNINTENDED EQUIPMENT OPERATION**

- Do not use this product as the only means of control for critical system functions such as motor start/stop or power control.
- Do not use this equipment as the only notification device for critical alarms, such as device overheating or overcurrent.
- Use only the software provided with this product. If you use another software, please confirm the operation and safety before use.

**Failure to follow these instructions can result in death, serious injury, or equipment damage.**



The following characteristics are specific to the LCD panel and are considered normal behavior:

- LCD screen may show unevenness in the brightness of certain images or may appear different when seen from outside the specified viewing angle. Extended shadows, or crosstalk may also appear on the sides of screen images.
- LCD screen pixels may contain black and white colored spots and color display may seem to have changed.
- When the same image is displayed on the screen for a long period, an afterimage may appear when the image is changed.
- The panel brightness may decrease when used for a long time in an environment continuously filled with inert gas. To prevent deterioration of panel brightness, regularly ventilate the panel. For more information, please contact your local distributor.

<http://www.pro-face.com/trans/en/manual/1015.html>

**NOTE:** Change the screen image periodically and try not to display the same image for a long period of time.

## CAUTION

### SERIOUS EYE AND SKIN INJURY

The liquid in the LCD panel contains an irritant:

- Avoid direct skin contact with the liquid.
- Wear gloves when you handle a broken or leaking unit.
- Do not use sharp objects or tools in the vicinity of the LCD panel.
- Handle the LCD panel carefully to prevent puncture, bursting, or cracking of the panel material.
- If the panel is damaged and any liquid comes in contact with your skin, immediately rinse the area with running water for at least 15 minutes. If the liquid gets in your eyes, immediately rinse your eyes with running water for at least 15 minutes and consult a doctor.

**Failure to follow these instructions can result in injury or equipment damage.**

### Cybersecurity Best Practices

To help keep your Pro-face products secure and protected, we recommend that you implement the cybersecurity best practices. Following the recommendations may help significantly reduce your company's cybersecurity risk. For the recommendations, refer to the following URL:

<https://www.pro-face.com/trans/en/manual/1087.html>



---

# Chapter 1

## Overview

---

### What Is in This Chapter?

This chapter contains the following topics:

Topic	Page
Model Numbers	12
Package Contents	13
Certifications and Standards	14
Federal Communication Commission Radio Frequency Interference Statement - For USA	16
Hazardous Location Installation - For USA and Canada	17

## Model Numbers

Series		Model name	Model number*1
GP-4100 Series Color Model	Ethernet type	GP-4114T	PFXGP4114T1D PFXGP4114T2D
	RS-232C type	GP-4115T	PFXGP4115T1D PFXGP4115T2D
		GP-4115T3	PFXGP4115T3D
	RS-422/485 type	GP-4116T	PFXGP4116T1D PFXGP4116T2D

\*1 Includes models with additional alphanumeric characters at the end of the model number.

### Model Number Configuration

The following describes the configuration of model numbers.

Digit Position	1	2	3	4	5	6	7	8	9	10	11	12
	P	F	X	(model)		(series)		(size)	(interface)	(LCD)	(backup memory)	(power supply)
				GP		41: GP-4100 Series		1: 4.3" (480 x 272 pixels)	4: Ethernet 5: RS-232C 6: RS-422/485	T: TFT color LCD	1: Not equipped (BLUE only) 2: Not equipped 3: Equipped	D: DC

### Global Code

A global code is assigned to every Pro-face product as a universal model number. For more information on product models and their matching global codes, please refer to the following URL.

<http://www.pro-face.com/trans/en/manual/1003.html>

## Package Contents

**NOTE:** This product has been carefully packed with special attention to quality. However, should you find anything damaged or missing, please contact your local distributor immediately.

Verify all items listed here are present in your package:

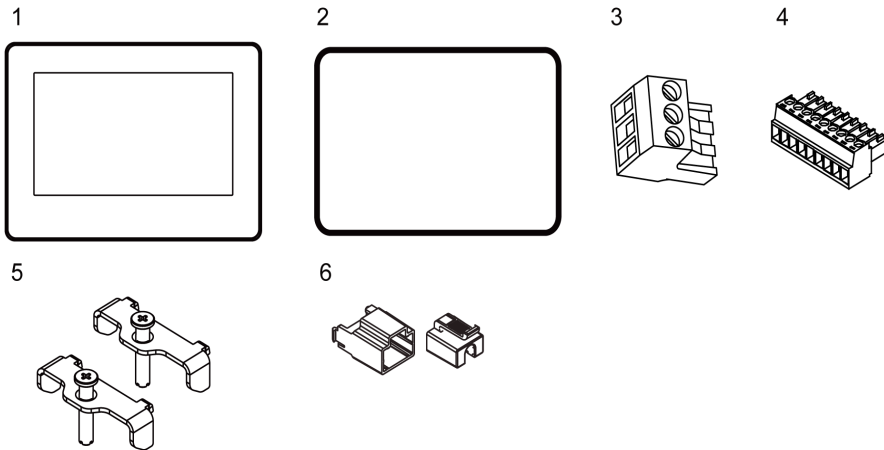

- 1 GP-4100 Series Color Model: 1
- 2 Installation Gasket: 1 (attached to this product)
- 3 DC Power Supply Connector: 1 (attached to this product)
- 4 COM I/F Connector: 1 (for RS-232C and RS-422/485 types)
- 5 Installation Fastener: 2 pieces/set
- 6 USB Clamp Type A (1 port): 1
- 7 GP-4100 Series Color Model Installation Guide: 1
- 8 Warning/Caution Information: 1

## Revision

You can identify the product version (PV), revision level (RL), and the software version (SV) from the product label.

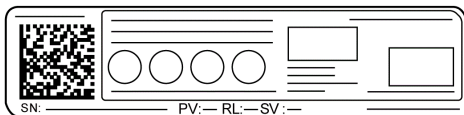

## Certifications and Standards

**NOTE:** The certifications and standards listed below may include those that are not yet acquired for this product. For the latest certifications and standards that this product has acquired, please check the product marking or the following URL.

<http://www.pro-face.com/trans/en/manual/1002.html>

### Agency Certifications

Schneider Electric submitted this product for independent testing and qualification by third-party listing agencies. These agencies have certified this product as meeting the following standards.

- Underwriters Laboratories Inc., UL61010-2-201 and CSA C22.2 N°61010-2-201, Industrial Control Equipment
- Underwriters Laboratories Inc., ANSI/ISA 12.12.01 and CSA C22.2 N°213, Electrical Equipment for Use in Class I, Division 2 Hazardous (Classified) Locations
- IECEx / ATEX for use in zones 2/22
- EAC certification (Russia, Belarus, Kazakhstan)
- American Bureau of Shipping (ABS)
- Det Norske Veritas - Germanischer Lloyd (DNV-GL)
- Lloyd's Register (LR)

### Compliance Standards

Europe:

CE

- Directive (2014/35/EU) (Low Voltage)
- Directive (2014/30/EU) (EMC)
  - Programmable Controllers: EN 61131-2
  - EN61000-6-4
  - EN61000-6-2
- Directive 94/9/EC (ATEX)
  - EN60079-0
  - EN60079-15
  - EN60079-31

Australia

- RCM
  - EN61000-6-4

Korea

- KC
  - KN11
  - KN61000-6-2

### Qualifications Standards

Schneider Electric voluntarily tested this product to additional standards. The additional tests performed, and the standards under which the tests were conducted, are specifically identified in Structural Specifications (*see page 33*).

### Hazardous Substances

This product is a device for use in factory systems. When using this product in a system, the system should comply with the following standards in regards to the installation environment and handling:

- WEEE, Directive 2012/19/EU
- RoHS, Directive 2011/65/EU and 2015/863/EU
- RoHS China, Standard GB/T 26572
- REACH regulation EC 1907/2006

### End of Life (WEEE)

The product contains electronic boards. It must be disposed of in specific treatment channels. The product contains cells and/or storage batteries which must be collected and processed separately, when they have run out and at the end of product life.

Refer to Maintenance (*see page 75*) to extract cells and batteries from the product. These batteries do not contain a weight percentage of heavy metals over the threshold notified by European Directive 2006/66/EC.

### European (CE) Compliance

The product described in this manual comply with the European Directives concerning Electromagnetic Compatibility and Low Voltage (CE marking) when used as specified in the relevant documentation, in application for which they are specifically intended, and in connection with approved third-party products.

### KC Markings

#### 사용자안내문

기종별	사용자안내문
A급 기기 (업무용 방송통신기자재)	이 기기는 업무용(A급) 전자파적합기기로서 판매자 또는 사용자는 이 점을 주의하시기 바라며, 가정외의 지역에서 사용하는 것을 목적으로 합니다.

## Federal Communication Commission Radio Frequency Interference Statement - For USA

### FCC Radio Interference Information

This product has been tested and found to comply with the Federal Communications Commission (FCC) limits for a Class A digital device, pursuant to Part 15 of the FCC Rules. These limits are designed to provide reasonable protection against harmful interference in a commercial, industrial or business environment. This product generates, uses, and can radiate radio frequency energy and, if not installed and used in accordance with the instructions, may cause or be subject to interference with radio communications. To minimize the possibility of electromagnetic interference in your application, observe the following two rules:

- Install and operate this product in such a manner that it does not radiate sufficient electromagnetic energy to cause interference in nearby devices.
- Install and test this product to ensure that the electromagnetic energy generated by nearby devices does not interfere with the operation of this product.
- Changes or modifications not expressly approved by the party responsible for compliance could void the user's authority to operate this product.

### **WARNING**

#### **ELECTROMAGNETIC / RADIO INTERFERENCE**

Electromagnetic radiation may disrupt the operation of this product leading to unintended equipment operation. If electromagnetic interference is detected:

- Increase the distance between this product and the interfering equipment.
- Reorient this product and the interfering equipment.
- Reroute power and communication lines to this product and the interfering equipment.
- Connect this product and the interfering equipment to different power supplies.
- Always use shielded cables when connecting this product to a peripheral device or another computer.

**Failure to follow these instructions can result in death, serious injury, or equipment damage.**



## Hazardous Location Installation - For USA and Canada

### General

This product has been designed with the intention of meeting the requirements of Class I, Division 2 hazardous location application. Division 2 locations are those locations where ignitable concentrations of flammable substances are normally confined, prevented by ventilation, or present in an adjacent Class I, Division 1 location, but where an abnormal situation might result in intermittent exposure to such ignitable concentrations.

While this product is a non-incendive device under ANSI/ISA 12.12.01 and CSA C22.2 N°213, it is not designed for, and should never be used within a Division 1 (normally hazardous) location.

This product is suitable for use in Class I, Division 2, Groups A, B, C, and D hazardous locations or in non-hazardous locations. Before installing or using this product, confirm that the ANSI/ISA 12.12.01 or CSA22.2 N°213 certification appears on the product labeling.

**NOTE:** Some products are not yet rated as suitable for use in hazardous locations. Always use your product in conformance with the product labeling and this manual.

### DANGER

#### POTENTIAL FOR EXPLOSION

- Do not use this product in hazardous environments or locations other than Class I, Division 2, Groups A, B, C, and D.
- Substitution of any component may impair suitability for Class I, Division 2.
- Do not connect or disconnect this product unless power has been switched off or the area is known to be non-hazardous.
- Always confirm that this product is suitable for use in hazardous locations by checking the ANSI/ISA 12.12.01 or CSA C22.2 N°213 certification appears on the product labeling.
- Do not install any Schneider Electric or OEM components, equipment, or accessories unless these have also been qualified as suitable for use in Class I, Division 2, Groups A, B, C, and D locations.
- Do not attempt to install, operate, modify, maintain, service, or otherwise alter this product except as permitted in this manual. Unpermitted actions may impair the suitability of this product for Class I, Division 2 operation.

**Failure to follow these instructions will result in death or serious injury.**

 **DANGER**

**POTENTIAL FOR EXPLOSION**

- Always confirm the ANSI/ISA 12.12.01 or CSA C22.2 N°213 hazardous location rating of your device before installing or using it in a hazardous location.
- To apply or remove the supply power from this product installed in a Class I, Division 2 hazardous location, you must either:
  - Use a switch located outside the hazardous environment, or;
  - Use a switch certified for Class I, Division 1 operation inside the hazardous area.
- Do not connect or disconnect equipment unless power has been switched off or the area is known to be non-hazardous. This applies to all connections including power, ground, serial, parallel, and network connections.
- Never use unshielded / ungrounded cables in hazardous locations.
- Use only non-incendive USB devices.
- When enclosed, keep enclosure doors and openings closed at all times to avoid the accumulation of foreign matter inside the workstation.

**Failure to follow these instructions will result in death or serious injury.**

  **DANGER**

**HAZARD OF ELECTRIC SHOCK, EXPLOSION, OR ARC FLASH**

- Remove all power from the device before removing any covers or elements of the system, and prior to installing or removing any accessories, hardware, or cables.
- Unplug the power cable from both this product and the power supply.
- Always use a properly rated voltage sensing device to confirm power is off.
- Replace and secure all covers or elements of the system before applying power to this product.
- Use only the specified voltage when operating this product. This product is designed to use 12 to 24 Vdc. Always check whether your device is DC powered before applying power.

**Failure to follow these instructions will result in death or serious injury.**

Make sure that this product is properly rated for the location. If the intended location does not presently have a Class, Division and Group rating, then users should consult the appropriate authorities having jurisdiction in order to determine the correct rating for that hazardous location.

## Operation and Maintenance

The systems have been designed for compliance with relevant spark ignition tests.

### DANGER

#### POTENTIAL FOR EXPLOSION

In addition to the other instructions in this manual, observe the following rules when installing this product in a hazardous location:

- Wire the equipment in accordance with the National Electrical Code article 501.10 (B) for Class I, Division 2 hazardous locations.
- Install this product in an enclosure suitable for the specific application. IP65F, Type 1, Type 4X (indoor use only), or Type 13 enclosures are recommended even when not required by regulations.

**Failure to follow these instructions will result in death or serious injury.**

**NOTE:** IP65F is not part of UL certification.



---

# Chapter 2

## Device Connectivity

---

### What Is in This Chapter?

This chapter contains the following topics:

Topic	Page
System Design	22
Accessories	23

## System Design

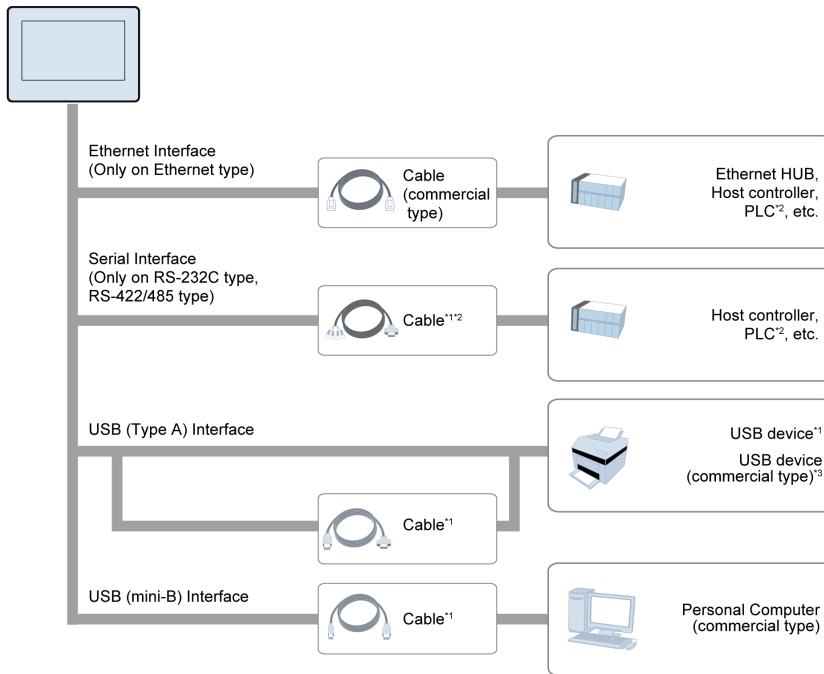

\*1 Refer to Accessories (*see page 23*).

\*2 For information on how to connect controllers and other types of equipment, refer to the corresponding device driver manual of your screen editing software.

\*3 For supported models, refer to our support site (<http://www.pro-face.com/trans/en/manual/1001.htm>).

**NOTE:** If connecting a bar code reader to this product, be sure to supply power from an external source (such as a self-powered hub). If you supply power from this product, it may reset itself because this product cannot supply enough power.

## Accessories

For host controllers and connection cables, refer to the corresponding device driver manual of your screen editing software.

Product name		Product number	Description
USB (Type A) interface	USB Front Cable (1 m)	CA5-USBEXT-01	Extension cable attaching USB interface to front panel.
	USB Transfer Cable (2 m) <sup>*1</sup>	CA3-USBCB-01	Via USB interface, downloads the project data created with the screen editing software.
	USB-Serial (RS-232C) Conversion Cable (0.5 m) <sup>*1</sup>	CA6-USB232-01	Cable for converting a USB interface into a serial interface (RS-232C). Allows connection to modems <sup>*2</sup> or bar code readers <sup>*2</sup> that support RS-232C.
	USB/RS-422/485 Conversion Adapter <sup>*1</sup>	PFXZCBCBCVUSR41	Adapter for connecting this product (USB Type A) to an external device (RS-422/RS-485).
	EZ Illuminated Switch <sup>*1</sup>	PFXZCCEUSG1	A unit of 5 illuminated switches with multiple color LED connected to this product via USB.
	EZ Fingerprint Recognition Unit <sup>*1</sup>	PFXZCCEUSS1	Fingerprint recognition unit connected to this product via USB.
	EZ Numpad <sup>*1</sup>	PFXZCCEUKB1	Numpad connected to this product via USB.
	EZ Tower Light tube mounting with fixing plate <sup>*1</sup>	PFXZCETWHA1	USB Connection Type Monolithic EZ Tower Light tube mounting with fixing plate 3 tiers, Ø60, lighting and flashing with a buzzer
	EZ Tower Light with base mounting <sup>*1</sup>	PFXZCETWW1	USB Connection Type Monolithic EZ Tower with base mounting 3 tiers, Ø60, lighting and flashing with a buzzer
USB (mini-B) interface	USB Transfer Cable (USB Type A/mini-B) (1.8 m)	ZC9USCBMB1	Cable for transferring screen data from a PC (USB Type A) to this product (USB mini-B).
	USB Panel-mount Extension Cable (USB mini-B) (1 m)	ZC9USEXMB1	Extension cable that attaches to the USB (mini-B) interface on the front side of the operation panel.
	USB Clamp mini-B (1 port)	ZC9USCLMB1	Clamp to prevent disconnection of USB cable (USB/mini-B, 1 port, 5 clamps/set).
UV Protection Sheet		PFXZCFUV43	Sheet to protect the display from dirt and ultraviolet light.
Panel Cutout Adapter		PFXZCFAD31	Attachment for mounting this product into the panel cutout for a GP-4100 series monochrome model (GP-410*).
RTC Battery Set		PFXZGPRTC1	Module for retaining the system date and time in the event the power is disconnected.
Battery for Data Backup <sup>*3</sup>		PFXZGEBT1	Primary battery for time data backup (1 piece).

\*1 Make sure your screen editing software supports the product.

\*2 For supported models, refer to our support site (<http://www.pro-face.com/trans/en/manual/1001.html>).

\*3 Replacement battery for the RTC Battery Set.

**Maintenance Accessories**

<b>Product name</b>	<b>Product number</b>	<b>Description</b>
Installation Fastener	PFXZCF31	Fasteners for installing this product into a panel (2 pieces).
Installation Gasket	PFXZCFWG32	Provides dust and moisture resistance when this product is installed into a solid panel (1 piece).
USB Clamp Type A (1 port)	ZC9USCL1	USB (Type A) clamp for 1 port products to prevent disconnection of USB cable (5 clamps/set).
DC Power Supply Connector	ZCACNDCS1	Connector to connect DC power supply cables (5 pieces).



---

# Chapter 3

## Parts Identification and Functions

---

### What Is in This Chapter?

This chapter contains the following topics:

Topic	Page
GP-4100 Series Color Model	26
LED Indications	27

## GP-4100 Series Color Model

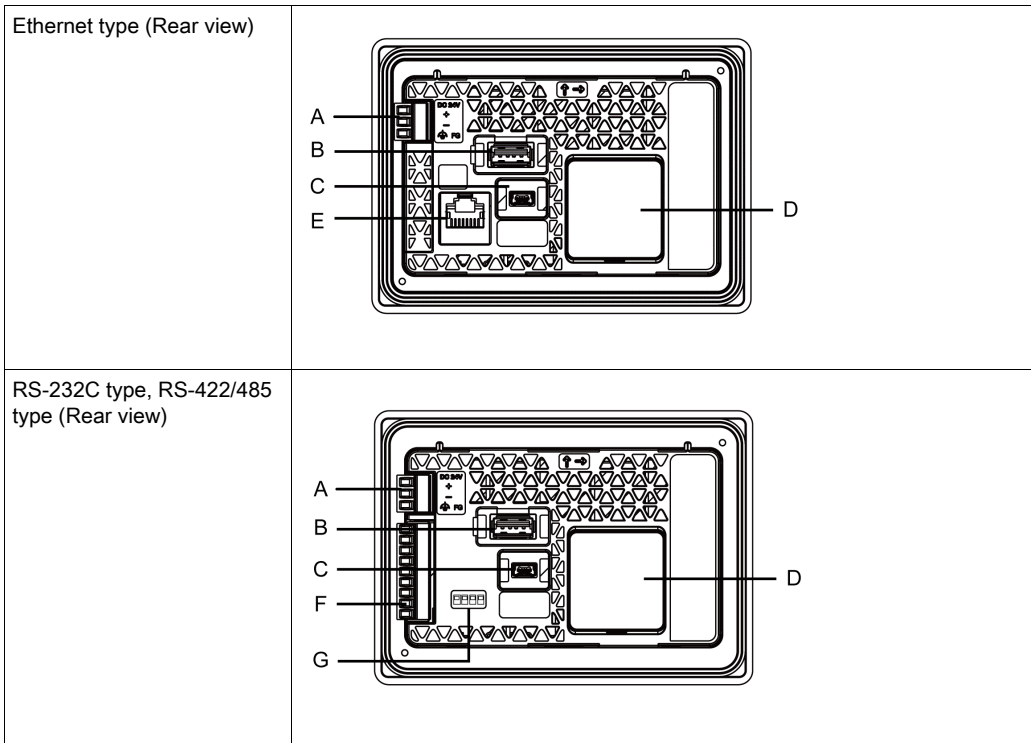

**A:** Power connector

**B:** USB (Type A) interface. *(see page 39)*

**C:** USB (mini-B) interface. *(see page 39)*

**D:** RTC Battery Set cover. You can embed the RTC Battery Set (model number: PFXZGPRTC1) into the RTC Battery Set Cover opening. *(see page 72)*

**E:** Ethernet interface. *(see page 39)*

**F:** Serial interface. *(see page 39)*

**G:** DIP switch. Only on RS-422/485 type. *(see page 41)*

## LED Indications

### LEDs for Ethernet Interface LED

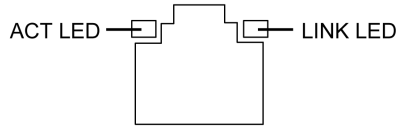

LED	Status	Description
Link	Green ON	Data transmission available
	Green OFF	No connection or subsequent transmission failure
Act	Green ON	Data transmission is occurring
	Green OFF	No data transmission



---

# Chapter 4

## Specifications

---

### What Is in This Chapter?

This chapter contains the following sections:

Section	Topic	Page
4.1	General Specifications	30
4.2	Functional Specifications	35
4.3	Interface Specifications	38

# Section 4.1

## General Specifications

---

### What Is in This Section?

This section contains the following topics:

Topic	Page
Electrical Specifications	31
Environmental Specifications	32
Structural Specifications	33

## Electrical Specifications

Specification		GP-4114T	GP-4115T GP-4115T3	GP-4116T	
Power supply	Rated input voltage	12...24 Vdc			
	Input voltage limits	10.2...28.8 Vdc			
	Voltage drop	12 Vdc: 1 ms or less 24 Vdc: 3 ms or less			
	Power consumption	When power is not supplied to USB devices	3.9 W or less	3.4 W or less	3.6 W or less
		When power is supplied to USB devices	8.1 W or less	7.5 W or less	7.7 W or less
	In-rush current	12 Vdc: 20 A or less 24 Vdc: 40 A or less			
Voltage endurance		1,000 Vac, 20 mA for 1 minute (between charging and FG terminals)			
Insulation resistance		500 Vdc, 10 MΩ or more (between charging and FG terminals)			

## Environmental Specifications

Physical environment	Surrounding air temperature	0...50 °C (32...122 °F)*1
	Storage temperature	-20...60 °C (-4...140 °F)
	Surrounding air and storage humidity	10%...90% RH (Non condensing, wet bulb temperature 39 °C [102.2 °F] or less)
	Dust	0.1 mg/m <sup>3</sup> (10 <sup>-7</sup> oz/ft <sup>3</sup> ) or less (non-conductive levels)
	Pollution degree	For use in Pollution Degree 2 environment
	Corrosive gases	Free of corrosive gases
	Atmospheric pressure (operating altitude)	800...1,114 hPa (2,000 m [6,561 ft] or lower)
Mechanical environment	Vibration resistance	IEC/EN 61131-2 compliant 5...9 Hz Single amplitude 3.5 mm (0.14 in) 9...150 Hz Fixed acceleration: 9.8 m/s <sup>2</sup> X, Y, Z directions for 10 cycles (approximately 100 minutes)
	Shock resistance	IEC/EN 61131-2 compliant 147 m/s <sup>2</sup> , X, Y, Z directions for 3 times
Electrical environment	Electrostatic discharge immunity	Contact discharge method: 6 kV (IEC/EN 61000-4-2 Level 3)

\*1 The designated range for the surrounding air temperature is 0 to 45 °C (32 to 113 °F) when the output current of USB (Type A) interface is from 0.25 A to 0.5 A.

**NOTE:** When using any of the options for this product, make sure to check the specifications for any special conditions or cautions that may apply to this product.

### Air quality requirements

Do not operate or store this product where chemicals evaporate, or where chemicals are present in the air:

- Corrosive chemicals: Acids, alkalines, liquids containing salt.
- Flammable chemicals: Organic solvents.

⚠ CAUTION
INOPERATIVE EQUIPMENT
Do not allow water, liquids, metal, and wiring fragments to enter the panel case.
<b>Failure to follow these instructions can result in injury or equipment damage.</b>



## Structural Specifications

Grounding	Functional grounding: Grounding resistance of 100 $\Omega$ , 2 mm <sup>2</sup> (AWG 14) or thicker wire, or your country's applicable standard (same for FG and SG terminals).
Cooling method	Natural air circulation
Structure* <sup>1</sup>	IP65F, Type 1, Type 4X (indoor use only), Type 13 * on the front panel when properly installed in an enclosure.
External dimensions	Refer to Dimensions ( <i>see page 45</i> ).
Panel cutout dimensions	Refer to Panel Cutout Dimensions ( <i>see page 54</i> ).
Weight	0.22 kg (0.49 lb) or less

\*1 The front face of this product, installed in a solid panel, has been tested using conditions equivalent to the standards shown in the specification. Even though this product's level of resistance is equivalent to these standards, oils that should have no effect on this product can possibly harm this product. This can occur in areas where either vaporized oils are present, or where low viscosity cutting oils are allowed to adhere to this product for long periods of time. If this product's front face protection sheet peels off, these conditions can lead to the ingress of oil into this product and separate protection measures are suggested.

Also, if non-approved oils are present, they may cause deformation or corrosion of the front panel's plastic cover. Therefore, prior to installing this product, be sure to confirm the type of conditions that will be present in this product's operating environment. If the installation gasket is used for a long period of time, or if this product and its gasket are removed from the panel, the original level of protection cannot be kept. To maintain the original protection level, be sure to replace the installation gasket regularly.

### CAUTION

#### EQUIPMENT DAMAGE

- Ensure this product is not in permanent and direct contact with oils.
- Do not press on the display of this product with excessive force or with a hard object.
- Do not press on the touch panel with a pointed object, such as the tip of a mechanical pencil or a screwdriver.

**Failure to follow these instructions can result in injury or equipment damage.**

### CAUTION

#### EQUIPMENT DAMAGE

Do not expose the device to direct sunlight.

**Failure to follow these instructions can result in injury or equipment damage.**

***NOTICE***

**STORAGE AND OPERATION OUTSIDE OF SPECIFICATIONS**

- Store this product in areas where temperatures are within the product's specifications.
- Do not restrict or block this product's ventilation slots.

**Failure to follow these instructions can result in equipment damage.**

***NOTICE***

**GASKET AGING**

- Inspect the gasket periodically as required by your operating environment to keep the initial IP level.
- Change the gasket at least once a year, or as soon as scratches or dirt become visible.

**Failure to follow these instructions can result in equipment damage.**

---

## Section 4.2

### Functional Specifications

---

#### What Is in This Section?

This section contains the following topics:

Topic	Page
Display Specifications	36
Memory, Clock, Touch Panel	37

## Display Specifications

Display type	TFT Color LCD
Display size	4.3"
Resolution	480 x 272 pixels
Effective display area (W x H)	95 x 53.9 mm (3.74 x 2.12 in)
Display colors	65,536 colors For details about display colors, refer to the manual for your screen editing software.
Backlight	White LED (Not user replaceable. When replacement is required, contact your local distributor.)
Backlight service life	50,000 hours or more (continuous operation at 25 °C [77 °F] before backlight brightness decreases to 50%)
Brightness control	16 levels (Adjusted with touch panel)

## Memory, Clock, Touch Panel

### Memory

System memory *1	Flash EPROM 128 MB Operating system, project data (screen data) and other data.
Backup memory *1	<ul style="list-style-type: none"> <li>● GP-4115T3 NVRAM 512 KB</li> <li>● Models other than GP-4115T3 Uses a part of Flash EPROM as the backup area</li> </ul>

\*1 For the usage capacity of each memory, refer to the following URL.

<https://www.pro-face.com/trans/en/manual/1082.html>

### Clock

Variations in operating conditions can cause clock deviations from -380 to +90 seconds per month. For systems where this level of precision is insufficient, the user should monitor and make adjustments when required.

Turning OFF or resetting this product initializes the clock.

To back up clock data, you need the RTC Battery Set (model number PFXZGPRTC1). Refer to the RTC Battery Set (*see page 72*).

### Touch Panel

Touch panel type	Resistive film (analog)
Touch panel resolution	1,024 x 1,024
Touch panel service life	1 million times or more

The touch panel does not support two point touch (multiple point touch). If you touch multiple points on the touch panel, it will operate as if you touched the center-point of the multiple touches.

For example, if you touch two or more points on the touch panel and at the center of the touches is a switch for a drive system, even though you did not directly touch that switch, it may function as if you did.

## WARNING

### UNINTENDED EQUIPMENT OPERATION

Do not simultaneously touch two or more points on the touch panel.

**Failure to follow these instructions can result in death, serious injury, or equipment damage.**

# Section 4.3

## Interface Specifications

---

### What Is in This Section?

This section contains the following topics:

Topic	Page
Interface Specifications	39
Interface Connection	40
Serial Interface	41

## Interface Specifications

Serial interface (Only on RS-232C type)	Asynchronous transmission	RS-232C
	Data length	7 or 8 bits
	Stop bit	1 or 2 bits
	Parity	None, odd, or even
	Data transmission speed	2,400...115,200 bps
	Connector	2-piece terminal block 9 pin x 1
Serial interface (Only on RS-422/485 type)	Asynchronous transmission	RS-422/485
	Data length	7 or 8 bits
	Stop bit	1 or 2 bits
	Parity	None, odd, or even
	Data transmission speed	2,400...115,200 bps
	Connector	2-piece terminal block 9 pin x 1
USB (Type A) interface	Connector	USB 2.0 (Type A) x 1
	Power supply voltage	5 Vdc $\pm$ 5%
	Maximum current supplied	500 mA/port
	Maximum transmission distance	Less than 3 m (9.84 ft)
USB (mini-B) interface	Connector	USB 2.0 (mini-B) x 1
	Maximum transmission distance	Less than 3 m (9.84 ft)
Ethernet interface (Only on Ethernet type)	Standard	IEEE802.3u, 10BASE-T/100BASE-TX
	Connector	Modular jack (RJ-45) x 1

## Interface Connection

### Cable Connections

#### DANGER

##### POTENTIAL FOR EXPLOSION

- Always confirm the ANSI/ISA 12.12.01 or CSA C22.2 N°213 hazardous location rating of your device before installing or using it in a hazardous location.
- To apply or remove the supply power from this product installed in a Class I, Division 2 hazardous location, you must either:
  - Use a switch located outside the hazardous environment, or;
  - Use a switch certified for Class I, Division 1 operation inside the hazardous area.
- Do not connect or disconnect equipment unless power has been switched off or the area is known to be non-hazardous. This applies to all connections including power, ground, serial, parallel, and network connections.
- Never use unshielded / ungrounded cables in hazardous locations.
- Use only non-incendive USB devices.
- Confirm that the USB cable has been attached with the USB clamp before using the USB host interface.
- Use the USB (mini-B) interface for temporary connection only during maintenance and setup of the device.
- Do not use the USB (mini-B) interface in hazardous locations.
- When enclosed, keep enclosure doors and openings closed at all times to avoid the accumulation of foreign matter inside the workstation.

**Failure to follow these instructions will result in death or serious injury.**

Division 2 hazardous location regulations require that all cable connections be provided with adequate strain relief and positive interlock. Never connect or disconnect a cable while power is applied at either end of the cable. All communication cables should include a chassis ground shield. This shield should include both copper braid and aluminum foil. The D-sub style connector housing must be a metal conductive type (for example, molded zinc) and the ground shield braid must be terminated directly to the connector housing. Do not use a shield drain wire.

The outer diameter of the cable must be suited to the inner diameter of the cable connector strain relief so that a reliable degree of strain relief is maintained. Always secure the D-sub connectors to the workstation-mating connectors via the two screws located on both sides.

When the transfer cable connects this product's USB (mini-B) interface with your computer, even if the power cable is not supplying power to this product, you can still transfer screen data. However, other functions will not operate properly. Additionally, the screen display will be dark.

#### WARNING

##### UNINTENDED EQUIPMENT OPERATION

Do not power this product via the USB (mini-B) interface instead of DC power during operation.

**Failure to follow these instructions can result in death, serious injury, or equipment damage.**



## Serial Interface

### Introduction

For information on how to connect controllers and other types of equipment, refer to the corresponding device driver manual of your screen editing software.

The serial interface is not isolated. The SG (signal ground) and the FG (functional ground) terminals are connected inside this product.

Use only the SELV (Safety Extra-Low Voltage) circuit to connect the COM, USB, and LAN interfaces.



DANGER

**ELECTRIC SHOCK AND FIRE**

When using the SG terminal to connect an external device to this product:

- Verify that a short-circuit loop is not created when you set up the system.
- Connect the SG terminal to remote equipment when the external device is not isolated.
- Connect the SG terminal to a known reliable ground connection to reduce the risk of damaging the circuit.

**Failure to follow these instructions will result in death or serious injury.**

CAUTION

**LOSS OF COMMUNICATION**

- Do not put excessive stress on the communication ports of all connections.
- Securely attach communication cables to the panel wall or cabinet.

**Failure to follow these instructions can result in injury or equipment damage.**

**NOTE:** Use within the rated current.

### RS-232C

COM I/F Connector (9-pin, 2-piece terminal block)

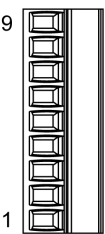
Cable connection side	Pin No.	RS-232C		
		Signal name	Direction	Meaning
	1	CI (RI)	Input	Called status display
	2	CD	Input	Carrier detect
	3	CS (CTS)	Input	Send possible
	4	RS (RTS)	Output	Request to send
	5	SG	–	Signal ground
	6	DR (DSR)	Input	Data set ready
	7	ER (DTR)	Output	Data terminal ready
	8	RD (RXD)	Input	Receive data
	9	SD (TXD)	Output	Send data

**RS-422/485**

COM I/F Connector (9-pin, 2-piece terminal block)

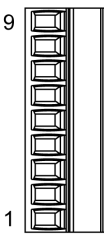
Cable connection side	Pin No.	RS-422/RS-485		
		Signal name	Direction	Meaning
	1	CSB	Input	Send possible B (-)
	2	CSA	Input	Send possible A (+)
	3	ERB	Output	Data terminal ready B (-)
	4	ERA	Output	Data terminal ready A (+)
	5	SG	-	Signal ground
	6	RDB	Input	Receive data B (-)
	7	RDA	Input	Receive data A (+)
	8	SDB	Output	Send data B (-)
	9	SDA	Output	Send data A (+)

**NOTE:** You can set a termination resistor using the DIP Switch (4-bit) on the rear of the RS-422/485 type. Factory default settings are “OFF” (no termination resistor). Check the termination resistor requirement for connection to the connected device (PLC) and set up if necessary.

**Communication Cable Specifications**

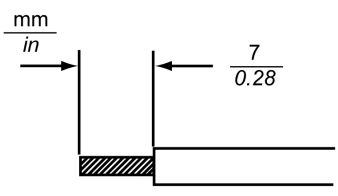
Communication cable diameter* <sup>1</sup>	0.14...1.5 mm <sup>2</sup> (AWG 28...16)
Conductor type	Simple or Stranded Wire* <sup>2</sup>
Conductor length	

\*1 When inserting two wires into one terminal connector, the simple wire diameter is 0.08 to 0.5 mm<sup>2</sup> (AWG 28 to 22), and the stranded wire diameter is 0.08 to 0.75 mm<sup>2</sup> (AWG 28 to 20).

\*2 If the conductor's stranded wires are not twisted correctly, the ends of the wires may either short against each other, or against an electrode.

## Wiring the COM Interface Connector

**⚡ ⚠ DANGER****ELECTRIC SHOCK**

Always disconnect the connector from this product before wiring the connector.

**Failure to follow these instructions will result in death or serious injury.**

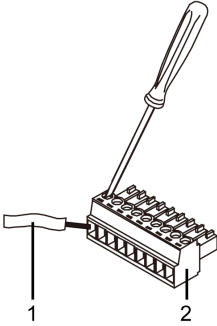
Step	Action
1	Use a flat-blade screwdriver (Size 0.4 X 2.5) to loosen the terminal screws.
2	Strip the communications cable, and attach it to the terminal connector.   <p>1 Communication cable 2 COM I/F Connector</p>
3	Use a flat-blade screwdriver to tighten the terminal screws on the terminal connector from step 2. <b>NOTE:</b> The torque required to tighten these screws is 0.196 N·m (1.735 lb-in).
4	Insert the connector to this product's serial interface.

***NOTICE*****BROKEN ENCLOSURE**

Do not exert more than 0.196 N·m (1.735 lb-in) of torque when tightening the screws.

**Failure to follow these instructions can result in equipment damage.**



---

# Chapter 5

## Dimensions

---

### What Is in This Chapter?

This chapter contains the following topics:

Topic	Page
External Dimensions	46
Dimensions with Installation Fasteners Attached	47
Installation Fastener Dimensions	48

## External Dimensions

**NOTE:** External view is shown using first angle projection method.

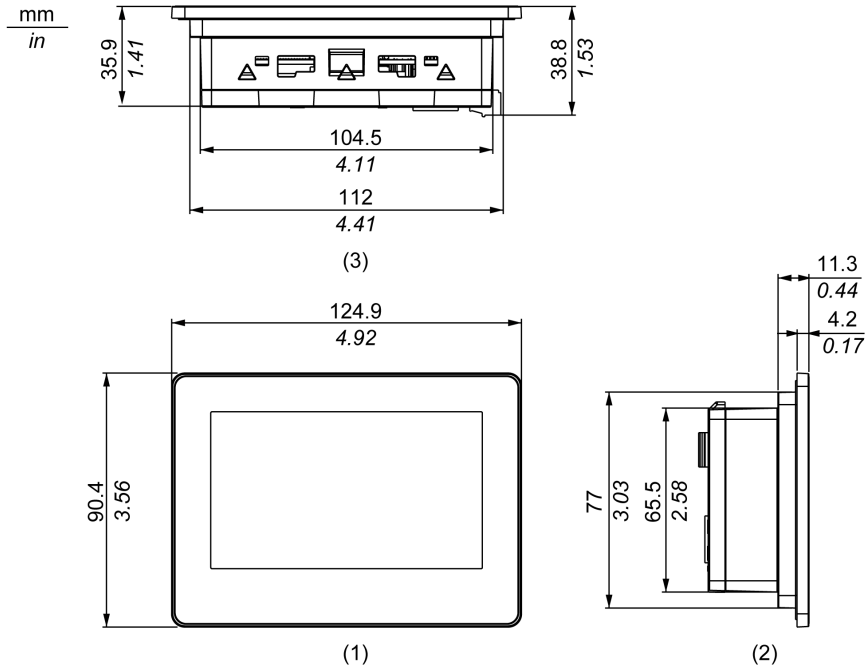

- 1 Front
- 2 Left
- 3 Bottom

## Dimensions with Installation Fasteners Attached

**NOTE:** External view is shown using first angle projection method.

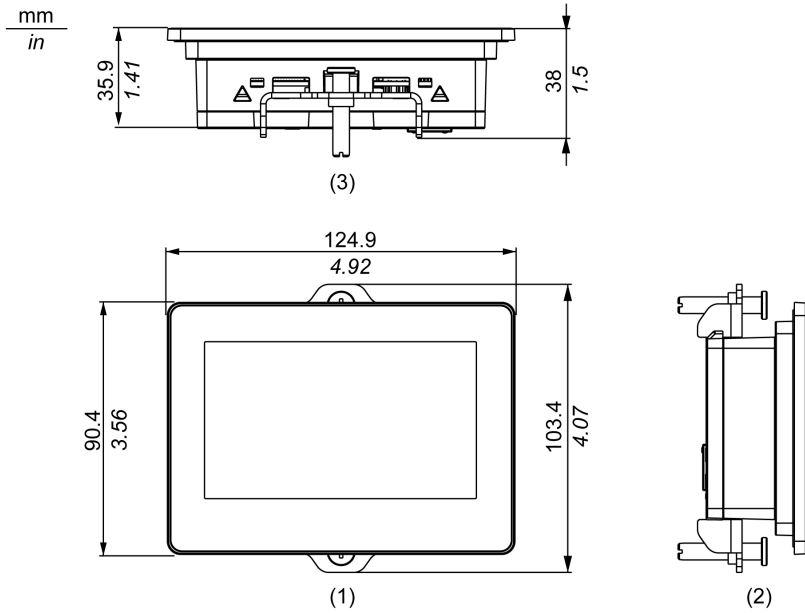

### Installation Fastener Dimensions

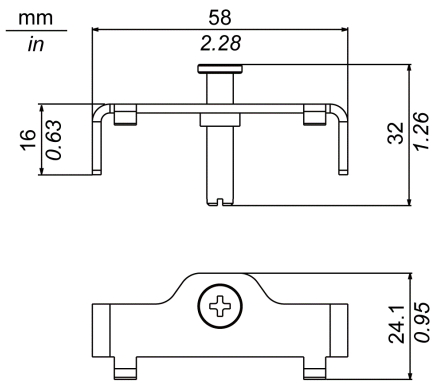



---

# Chapter 6

## Installation and Wiring

---

### What Is in This Chapter?

This chapter contains the following sections:

Section	Topic	Page
6.1	Installation	50
6.2	Wiring Principles	60
6.3	USB Clamp	66
6.4	RTC Battery Set	72

# Section 6.1

## Installation

---

### What Is in This Section?

This section contains the following topics:

Topic	Page
Introduction	51
Installation Requirements	52
Panel Cutout Dimensions	54
Panel Mounting Procedure A	55
Panel Mounting Procedure B	57

## Introduction

This product is designed for use on flat surfaces of Type 1, Type 4X (indoor use only), Type 13 Enclosure, or IP65F.

Be aware of the following when building this product into an end-use product:

- The rear face of this product is not approved as an enclosure. When building this product into an end-use product, be sure to use an enclosure that satisfies standards as the end-use product's overall enclosure.
- Install this product in an enclosure with mechanical rigidity.
- This product is not designed for outdoor use. UL certification obtained is for indoor use only.
- Install and operate this product with its front panel facing outward.

**NOTE:**

- IP65F is not part of the UL certification.
- The necessary torque to fasten the screws of the installation fasteners enclosed with the product is 0.35 N•m (3.1 lb-in).

## Installation Requirements

Check that the installation wall or cabinet surface is flat, in good condition and has no jagged edges. Metal reinforcing strips may be attached to the inside of the wall, near the panel cutout, to increase its rigidity.

Decide on the thickness of the enclosure wall, based on the level of strength required: 1.5..6 mm (0.06..0.24 in).

Even if the installation wall thickness is within the recommended range for the "Panel Cutout Dimensions", depending on wall's material, size, and installation location of this product and other devices, the installation wall could warp. To prevent warping, the installation surface may need to be strengthened.

Be sure that the surrounding air temperature and the ambient humidity are within their designated ranges (*see page 32*). When installing this product in a cabinet or enclosure, the surrounding air temperature is the cabinet's or enclosure's internal temperature.

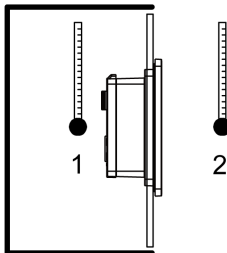

- 1 Cabinet interior
- 2 Panel face

Be sure that heat from surrounding equipment does not cause this product to exceed its standard operating temperature.

When mounting this product vertically, ensure that the left side of this product faces up. In other words, the DC power connector should be at the bottom.

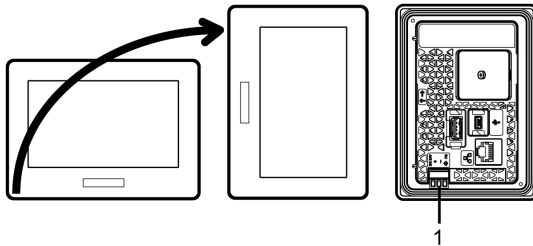

- 1 Power connector

**NOTE:** For vertical mounting, make sure your screen editing software supports the function.

When installing this product in a slanted position, the product face should not incline more than 30°.

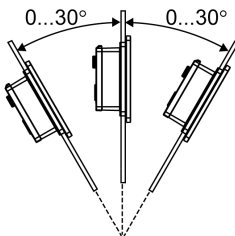

When installing this product in a slanted position with an incline more than 30°, the ambient temperature must not exceed 40 °C (104 °F). You may need to use forced air cooling (fan, A/C) to ensure the ambient operating temperature is 40 °C or less (104 °F or less).

For easier maintenance, operation and improved ventilation, install this product at least 100 mm (3.94 in) away from adjacent structures and other equipment as shown in the following illustration:

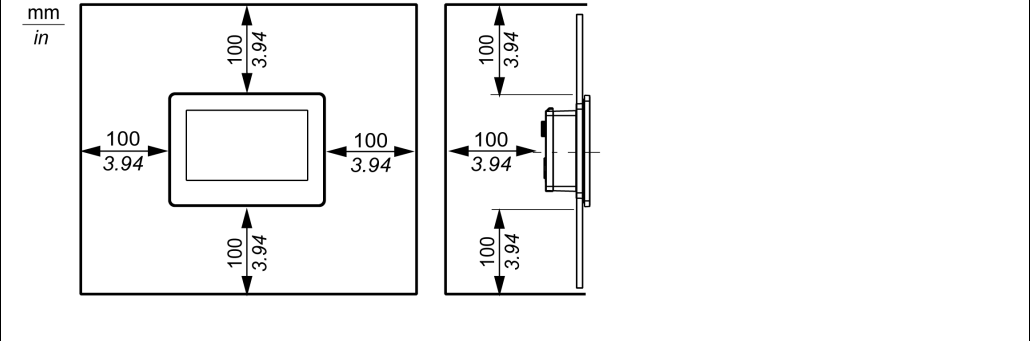

### Pressure Differences

When applying and installing this product, it is important that steps are taken to eliminate any pressure difference between the inside and the outside of the enclosure in which this product is mounted. Higher pressure inside the enclosure can cause delamination of the front membrane of the display. Even a small pressure difference inside the enclosure will act on the large area of the membrane and can result in sufficient force to delaminate the membrane and thus cause failure of the touch capability. Pressure differences can often occur in applications where there are multiple fans and ventilators moving air at different rates in different rooms. Please follow these techniques to ensure that this product's function is not impacted by this mis-application:

1. Seal all conduit connections inside of the enclosure, especially those that lead to other rooms that may be at a different pressure.
2. Where applicable, install a small weep hole at the bottom of the enclosure to allow equalization of the internal and external pressure.

## Panel Cutout Dimensions

Based on the panel cutout dimensions, open a mount hole on the panel.

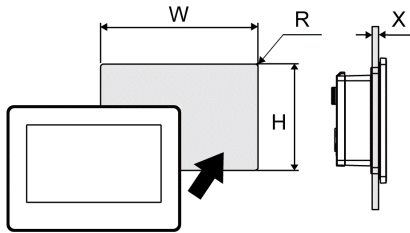

Panel cutout dimensions for color model

W	H	X	R
112.5 mm (+1/-0 mm) (4.43 in [+0.04/-0 in])	77.5 mm (+1/-0 mm) (3.05 in [+0.04/-0 in])	1.5...6 mm (0.06...0.24 in)	2...3 mm (0.08...0.12 in)

**NOTE:** For instructions on how to install this product to the panel cutout for color model, refer to Panel Mounting Procedure A (*see page 55*).

When installing to panel cutout for monochrome model (GP-410\*)

**NOTE:** The Panel Cutout Adapter (model number: PFXZCFAD31) is required for this type of installation. For instructions on how to install this product to the panel cutout for monochrome model (GP-410\*), refer to Panel Mounting Procedure B (*see page 57*).

W	H	X	R
105 mm (+1/-0 mm) (4.13 in [+0.04/-0 in])	66 mm (+1/-0 mm) (2.6 in [+0.04/-0 in])	1.5...6 mm (0.06...0.24 in)	2...3 mm (0.08...0.12 in)

## Panel Mounting Procedure A

### Installing to panel cutout for Color Model

#### **DANGER**

##### HAZARD OF ELECTRIC SHOCK, EXPLOSION, OR ARC FLASH

- Remove all power from the device before removing any covers or elements of the system, and prior to installing or removing any accessories, hardware, or cables.
- Unplug the power cable from both this product and the power supply.
- Always use a properly rated voltage sensing device to confirm power is off.
- Replace and secure all covers or elements of the system before applying power to this product.

**Failure to follow these instructions will result in death or serious injury.**

#### ***NOTICE***

##### EQUIPMENT DAMAGE

Keep this product stabilized in the panel-cut while you are installing or removing the screw fasteners.

**Failure to follow these instructions can result in equipment damage.**

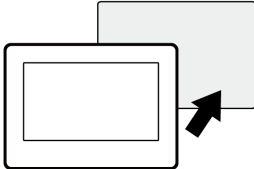
Step	Action
1	Place this product on a clean and level surface with the screen facing down.
2	<p>Check that this product's gasket is seated securely into the bezel groove, which runs around the perimeter of the display panel frame.</p> <p><b>NOTE:</b> Always use the installation gasket, since it absorbs vibration in addition to repelling water. For the procedure on replacing the installation gasket, refer to Replacing the Installation Gasket (<i>see page 78</i>).</p>
3	<p>Based on this product's panel cutout dimension (<i>see page 54</i>), open a mount hole on the panel and attach this product to the panel from the front side.</p> 

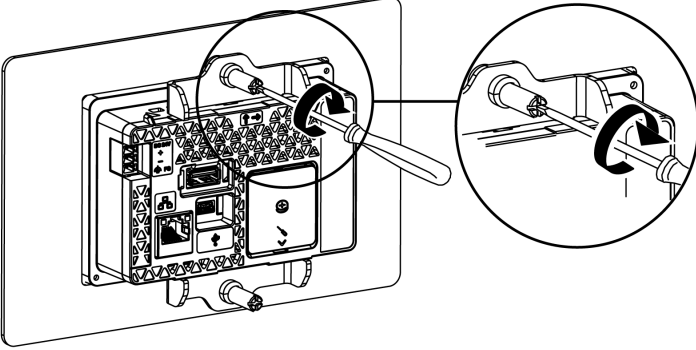
Step	Action
4	<p>Insert the installation fastener hooks into the insertion slots on this product. In a clockwise direction, tighten the installation fastener's screws with a screwdriver. There are two insertion slots on both the top and bottom of this product. The necessary torque is 0.35 N•m (3.1 lb-in).</p>  <p><b>NOTE:</b> If you exceed the recommended torque when tightening the installation fastener's screws, the front of this product may become distorted.</p>

## ***NOTICE***

### **BROKEN ENCLOSURE**

Do not exert more than 0.35 N•m (3.1 lb-in) of torque when tightening the fastener's screws.

**Failure to follow these instructions can result in equipment damage.**

## **⚠ CAUTION**

### **RISK OF INJURY**

Do not drop this product when you remove it from the panel.

- Hold this product in place after removing the fasteners.
- Use both hands.

**Failure to follow these instructions can result in injury or equipment damage.**



## Panel Mounting Procedure B

### Installing to panel cutout for Monochrome Model (GP-410\*)

The Panel Cutout Adapter (model number: PFXZCFAD31) is required for the following installation procedure.

- Panel Cutout Adapter specifications

Structure: IP65F\*<sup>1</sup> (The structural protection rating, when attaching the Panel Cutout Adapter on this product, depends on the rating of this product.

Weight: 26.5 g (0.06 lb) or less

\*1 IP65F is not part of the UL certification.

- Panel Cutout Adapter dimensions

The following drawing shows this product with the Panel Cutout Adapter.

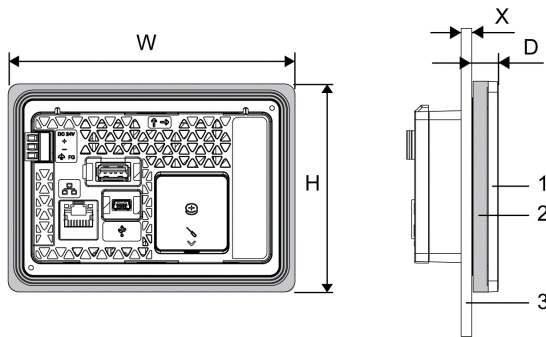

- 1 This product's panel
- 2 Panel Cutout Adapter
- 3 Installation panel

W and H are the same as the external dimensions of this product.

W: 124.9 mm (4.92 in)

H: 90.4 mm (3.56 in)

D: 11.3 mm (0.44 in)

X: 1.5...6 mm (0.06...0.24 in)

## DANGER

### HAZARD OF ELECTRIC SHOCK, EXPLOSION, OR ARC FLASH

- Remove all power from the device before removing any covers or elements of the system, and prior to installing or removing any accessories, hardware, or cables.
- Unplug the power cable from both this product and the power supply.
- Always use a properly rated voltage sensing device to confirm power is off.
- Replace and secure all covers or elements of the system before applying power to this product.

**Failure to follow these instructions will result in death or serious injury.**

## ***NOTICE***

### **EQUIPMENT DAMAGE**

Keep this product stabilized in the panel-cut while you are installing or removing the screw fasteners.

**Failure to follow these instructions can result in equipment damage.**

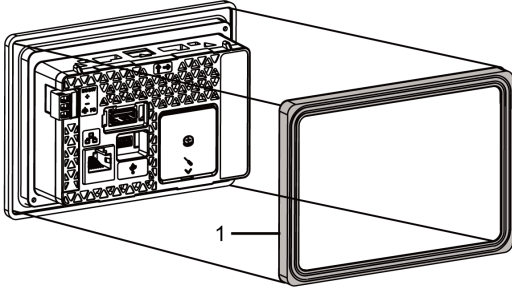
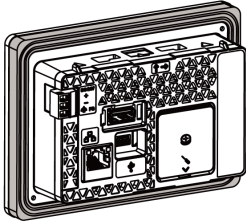
Step	Action
1	Place this product on a clean and level surface with the screen facing down.
2	Remove the gasket from this product.
3	<p>Attach the Panel Cutout Adapter (model number: PFXZCFAD31) to this product. Check that the Panel Cutout Adapter is seated securely into the bezel groove, which runs around the perimeter of the display panel frame.</p> <div style="text-align: center;">  </div> <p><b>1</b> Panel Cutout Adapter</p> <div style="text-align: center;">  </div> <p><b>NOTE:</b> Always use the Panel Cutout Adapter, since it absorbs vibration in addition to repelling water.</p>

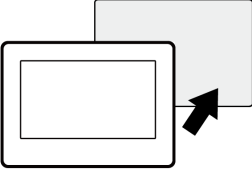
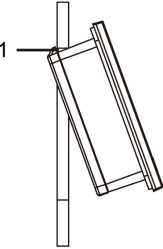
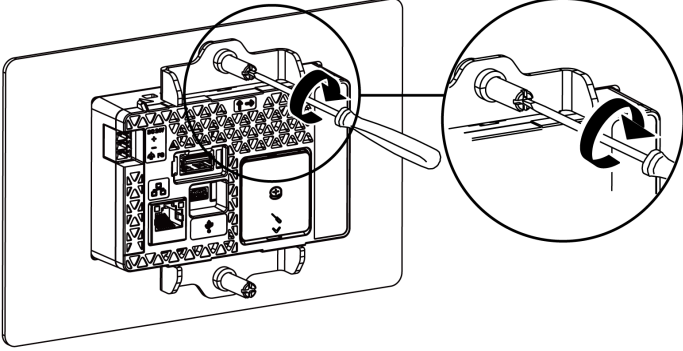
Step	Action
4	<p data-bbox="351 204 1222 256">From the front of the panel, attach this product to the mount hole for the monochrome model (see page 54).</p>  <p data-bbox="351 510 1238 562"><b>NOTE:</b> This product has two projections on the top to prevent falling during installation. Please insert this product into the panel at an angle to avoid hitting the projections.</p>  <p data-bbox="351 871 495 896">1 Projections</p>
5	<p data-bbox="351 909 1238 1012">Insert the installation fastener hooks into the insertion slots on this product. In a clockwise direction, tighten the installation fastener's screws with a screwdriver. There are two insertion slots on both the top and bottom of this product. The necessary torque is 0.35 N•m (3.1 lb-in).</p>  <p data-bbox="351 1441 1199 1491"><b>NOTE:</b> If you exceed the recommended torque when tightening the installation fastener's screws, the front of this product may become distorted.</p>

## ***NOTICE***

### **BROKEN ENCLOSURE**

Do not exert more than 0.35 N•m (3.1 lb-in) of torque when tightening the fastener's screws.

**Failure to follow these instructions can result in equipment damage.**

# Section 6.2

## Wiring Principles

---

### What Is in This Section?

This section contains the following topics:

Topic	Page
Connecting the DC Power Cord	61
Connecting the Power Supply	63
Grounding	65

## Connecting the DC Power Cord

### DANGER

#### HAZARD OF ELECTRIC SHOCK, EXPLOSION, OR ARC FLASH

- Remove all power from the device before removing any covers or elements of the system, and prior to installing or removing any accessories, hardware, or cables.
- Remove power before wiring this product's power terminals.
- Always use a properly rated voltage sensing device to confirm power is off.
- Replace and secure all covers or elements of the system before applying power to this product.
- Use only the specified voltage when operating this product. This product is designed to use 12 to 24 Vdc power. Always check whether your device is DC powered before applying power.
- Since this product is not equipped with a power switch, be sure to connect a power switch to the power supply.
- Be sure to ground this product's FG terminal.

**Failure to follow these instructions will result in death or serious injury.**

#### NOTE:

- The SG (signal ground) and FG (functional ground) terminals are connected internally in this product.
- When the FG terminal is connected, be sure the wire is grounded. Not grounding this product can result in excessive electromagnetic interference (EMI).

#### DC Power Cord Preparation

- Make sure the ground wire is either the same or heavier gauge than the power wires.
- Do not use aluminum wires in the power supply's power cord.
- If the ends of the individual wires are not twisted correctly, the wires may create a short circuit.
- The conductor type is solid or stranded wire.
- Use copper wire rated for 75 °C (167 °F) or higher.

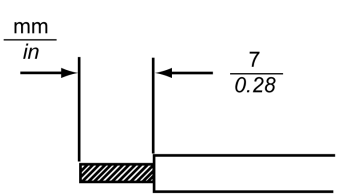
Power cord diameter	0.75...1.5 mm <sup>2</sup> (AWG 18...16)
Conductor type	Solid or stranded wire
Conductor length	

### DC Power Supply Connector Specifications

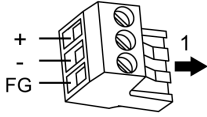
	Connection	Wire
 <p>1 Insertion direction</p>	+	12...24 Vdc
	-	0 Vdc
	FG	Grounded terminal connected to the panel chassis.

### How to connect the DC Power Cord

Step	Action
1	Confirm the power cord is not connected to the power supply.
2	Check the rated voltage and remove the "DC24V" sticker on the DC power supply connector.
3	Remove the power connector (plug) from this product.
4	Strip the membrane of the power cord, and connect them to the power connector. <b>NOTE:</b> <ul style="list-style-type: none"> <li>Use a flat-blade screwdriver (Size 0.4 x 2.5) to tighten the terminal screws. The torque require to tighten these screws is 0.22 to 0.25 N•m (1.95 to 2.2 lb-in).</li> <li>Do not solder the cable connection. Doing so may either damage this product due to abnormal heat or cause a fire.</li> </ul>
5	Reattach the power connector (plug).

## Connecting the Power Supply

### Precautions

#### **DANGER**

##### **SHORT CIRCUIT, FIRE, OR UNINTENDED EQUIPMENT OPERATION**

Avoid excessive force on the power cable to prevent accidental disconnection

- Securely attach power cables to an installation panel or cabinet.
- Use the designated torque to tighten this product's terminal block screws.
- Install and fasten this product on installation panel or cabinet prior to connecting power supply and communication lines.

**Failure to follow these instructions will result in death or serious injury.**

### Improving Noise/Surge Resistance

- This product's power supply cord should not be bundled with or kept close to main circuit lines (high voltage, high current), power lines, or input/output lines, and their various systems should be kept separate. When power lines cannot be wired via a separate system, use shielded cables for input/output lines.
- Make the power cord as short as possible, and be sure to twist the ends of the wires together (i.e. twisted pair cabling) from close to the power supply unit.
- If there is an excess amount of noise on the power supply line, connect a noise reducing transistor before turning on the power.
- Connect a surge protection device to handle power surges.
- To increase noise resistance, attach a ferrite core to the power cable.

### Power Supply Connections

- Use SELV (Safety Extra-Low Voltage) circuit and LIM (Limited Energy) circuit for DC input.
- When supplying power to this product, connect the power as shown below.

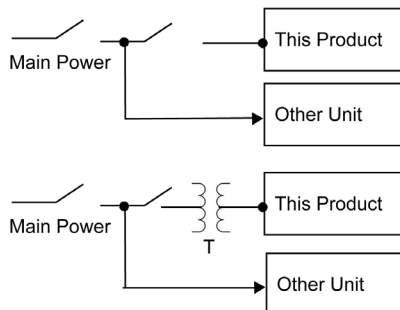

- The following shows a surge protection device connection:

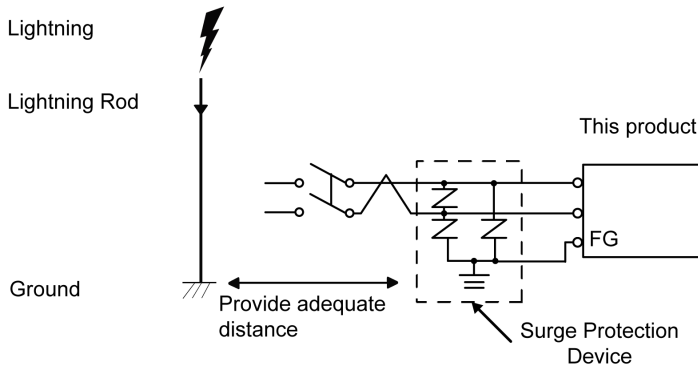

- Attach a surge protection device to prevent damage to this product as a result of a lightning-induced power surge from a large electromagnetic field generated from a direct lightning strike. We also strongly recommend to connect the crossover grounding wire of this product to a position close to the ground terminal of the surge protection device. It is expected that there will be an effect on this product due to fluctuations in grounding potential when there is a large surge flow of electrical energy to the lightning rod ground at the time of a lightning strike. Provide adequate distance between the lightning rod grounding point and the surge protection device grounding point.
- If the voltage variation is outside the prescribed range, connect a regulated power supply.

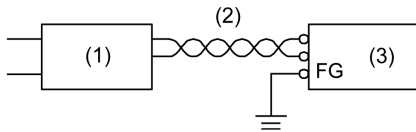

- 1 Regulated power supply
- 2 Twisted-pair cord
- 3 This product

- Select a power supply low in noise for between the line and ground. If there is an excessive amount of noise, connect an insulating transformer. Use isolating transformers with capacities exceeding the maximum power consumption (*see page 31*).

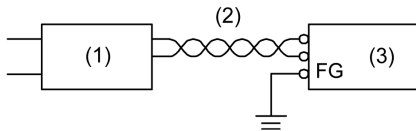

- 1 Insulating transformer
- 2 Twisted-pair cord
- 3 This product



## Grounding

### Exclusive Grounding

Always ground the FG (functional ground) terminal. Be sure to separate this product from the FG of other devices as shown below.

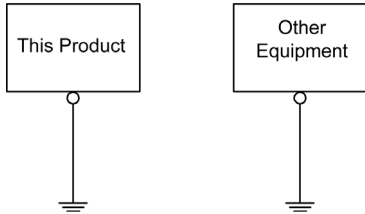

### Precautions

- Check that the grounding resistance is 100  $\Omega$  or less.\*1
- The FG wire should have a cross sectional area greater than 2 mm<sup>2</sup> (AWG14)\*1. Create the connection point as close to this product as possible, and make the wire as short as possible. When using a long grounding wire, replace the thin wire with a thicker wire, and place it in a duct.
- The SG (signal ground) and FG (functional ground) terminals are connected internally in this product. When connecting the SG line to another device, be sure that no ground loop is formed.

\*1 Observe local codes and standards.

### Common Grounding

Electromagnetic Interference (EMI) can be created if devices are improperly grounded. EMI can cause loss of communication. If exclusive grounding is not possible, use a common grounding point as shown in the configuration below. Do not use any other configuration for common grounding.

Correct grounding

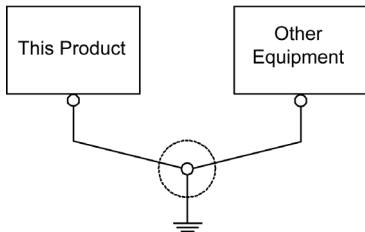

Incorrect grounding

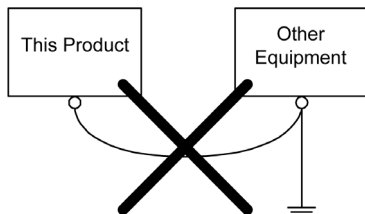

# Section 6.3

## USB Clamp

---

### What Is in This Section?

This section contains the following topics:

Topic	Page
USB Clamp Type A (1 port)	67
USB Clamp mini-B (1 port)	70

## USB Clamp Type A (1 port)

### Introduction

When using a USB device, attach a USB clamp to the USB interface to prevent the USB cable from being disconnected.

## ⚠ DANGER

### POTENTIAL FOR EXPLOSION

- Verify the power, input, and output (I/O) wiring are in accordance with Class I, Division 2 wiring methods.
- Substitution of any components may impair suitability for Class I, Division 2.
- Do not disconnect equipment while the circuit is live or unless the area is known to be free of ignitable concentrations.
- Remove power before attaching or detaching any connectors to or from this product.
- Ensure that power, communication, and accessory connections do not place excessive stress on the ports. Consider the vibration in the environment when making this determination.
- Securely attach power, communication, and external accessory cables to the panel or cabinet.
- Use only commercially available USB cables.
- Use only non-incendive USB configurations.
- Suitable for use in Class I, Division 2, Groups A, B, C, D Hazardous Locations.
- Confirm that the USB cable has been attached with the USB clamp before using the USB interface.

**Failure to follow these instructions will result in death or serious injury.**

### Attaching the USB Holder

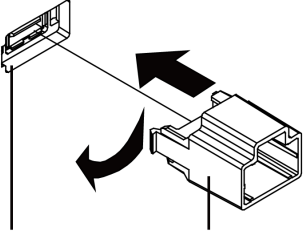
Step	Action
1	<p>Attach the USB holder to the USB (Type A) interface on this product. Hook the clip on the right-side of the USB holder into the slot beside the interface, then insert the left clip to attach.</p>  <p style="margin-left: 20px;">1                      2</p> <p>1 USB (Type A) interface 2 USB holder</p>

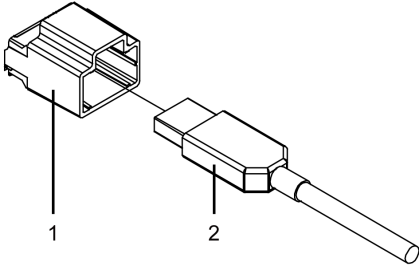
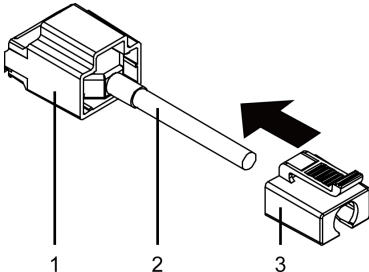
Step	Action
2	<p>Insert the USB cable into the USB (Type A) interface.</p>  <p>1 USB holder 2 USB cable</p>
3	<p>Attach the USB cover to fix the USB cable in place. Insert the USB cover into the USB holder.</p>  <p>1 USB holder 2 USB cable 3 USB cover</p>

### Removing the USB Holder

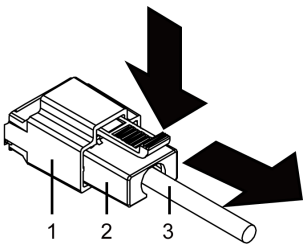
Step	Action
1	<p>Push down the tab of the USB cover and then remove the USB cover.</p>  <p>1 USB holder 2 USB cover 3 USB cable</p>
2	<p>Remove the USB cable from the USB (Type A) interface.</p>

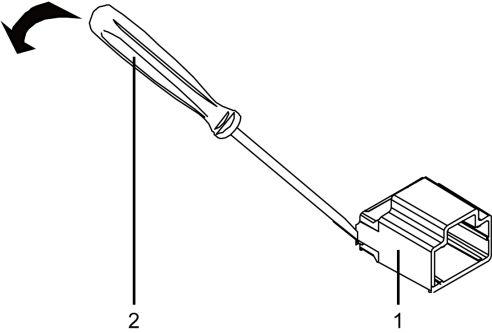
Step	Action
3	<p data-bbox="351 204 1222 253">As shown in the following illustration, insert a screwdriver between this product and the USB holder to pry out the USB holder.</p>  <p data-bbox="351 643 834 697">1 USB holder 2 Flat-blade screwdriver less than 6 mm (0.23 in)</p>
4	Remove the USB holder.

## USB Clamp mini-B (1 port)

### Introduction

When using a USB device, you can attach a USB clamp to the USB (mini-B) interface to prevent the USB cable from being disconnected.

 **DANGER**

**POTENTIAL FOR EXPLOSION**

- Verify the power, input, and output (I/O) wiring are in accordance with Class I, Division 2 wiring methods.
- Substitution of any components may impair suitability for Class I, Division 2.
- Confirm that the USB cable has been fixed with the USB clamp before using the USB interface.
- Remove power before attaching or detaching any connectors to or from this product.
- Use the USB (mini-B) interface for temporary connection only during maintenance and setup of the device.
- Do not use the USB (mini-B) interface in hazardous locations.

**Failure to follow these instructions will result in death or serious injury.**

### Attaching the USB Clamp

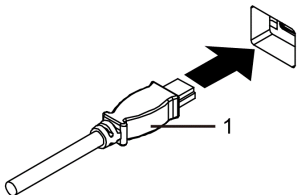
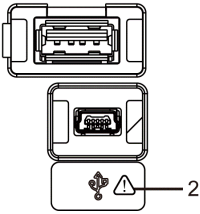
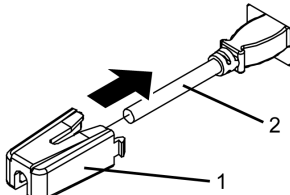
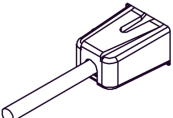
Step	Action
1	<p>Insert the USB cable into the USB (mini-B) interface.</p> <div style="display: flex; justify-content: space-around; align-items: center;">   </div> <p> <b>1</b> USB cable  <b>2</b> Safety alert symbol (see the safety messages above)                 </p>
2	<p>Attach the USB clamp to fix the USB cable in place. Insert the USB clamp into the USB (mini-B) interface.</p> <div style="display: flex; justify-content: space-around; align-items: center;">   </div> <p> <b>1</b> USB clamp  <b>2</b> USB cable                 </p>

### Removing the USB Clamp

Remove the USB clamp by pressing the tabs from the sides.

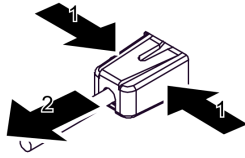

# Section 6.4

## RTC Battery Set

---

### What Is in This Section?

This section contains the following topics:

Topic	Page
Introduction	73
Attaching the RTC Battery Set	74



## Introduction

RTC Battery Set (model number: PFXZGPRTC1), provides system date and time information and supports related functions requiring a real-time clock. To keep time continuity when power is off, a non-rechargeable but replaceable lithium battery is provided with the RTC Battery Set.

### NOTE:

- Replacing the battery initializes the clock data.
- For instructions on how to replace the battery in the RTC Battery Set, refer to Replacing the Battery in the RTC Battery Set (*see page 79*).

## DANGER

### HAZARD OF ELECTRIC SHOCK, EXPLOSION, OR ARC FLASH

- Remove all power from the device before removing any covers or elements of the system, and prior to installing or removing any accessories, hardware, or cables.
- Unplug the power cable from both this product and the power supply.
- Always use a properly rated voltage sensing device to confirm power is off.
- Replace and secure all covers or elements of the system before applying power to this product.
- Use only the specified voltage when operating this product. This product is designed to use 12 to 24 Vdc. Always check whether your device is DC powered before applying power.

**Failure to follow these instructions will result in death or serious injury.**

## DANGER

### EXPLOSION, FIRE, OR CHEMICAL HAZARD

Follow these instructions for the lithium batteries:

- Use this product's replacement battery only.
- Protect battery from any potential short circuit.
- Recycle or properly dispose of used batteries.
- Do not recharge, disassemble or heat above 80 °C (176 °F).
- Use your hands or insulated tools to remove or replace the battery.
- Maintain proper polarity when inserting and connecting a new battery.

**Failure to follow these instructions will result in death or serious injury.**

## NOTICE

### LOSS OF DATA

- Replace the battery regularly every five years after you purchase the RTC Battery Set.
- Allow only qualified personnel to change the battery.

**Failure to follow these instructions can result in equipment damage.**

## Attaching the RTC Battery Set

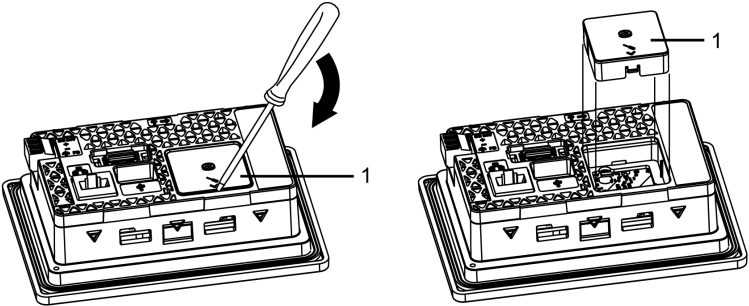
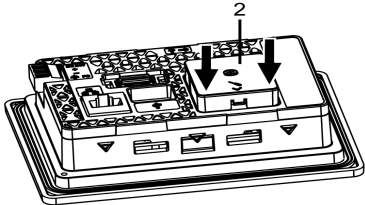
Step	Action
1	Disconnect the power supply from this product.
2	Touch the housing or ground connection to discharge any electrostatic charge from your body.
3	Place this product on a flat, level surface, with the rear side pointing up.
4	<p>Open the RTC Battery Set Cover on this product using a flat-blade screwdriver as illustrated:</p>  <p>1 RTC Battery Set Cover</p>
5	<p>Insert the RTC battery horizontal with the product, and push the points indicated by the arrows until the battery clicks into the product.</p>  <p>2 RTC Battery Set</p>
6	<p>Reconnect the power supply to this product.</p> <p><b>NOTE:</b> After reconnecting the power supply, set up the clock again. Refer to your screen editing software manual on how to set up the clock.</p>

---

# Chapter 7

## Maintenance

---

### What Is in This Chapter?

This chapter contains the following topics:

Topic	Page
Regular Cleaning	76
Periodic Check Points	77
Replacing the Installation Gasket	78
Replacing the Battery in the RTC Battery Set	79
Replacing the Backlight	81
After-sales Service	82

## Regular Cleaning

### Cleaning this product

### ***NOTICE***

#### **EQUIPMENT DAMAGE**

- Power off this product before cleaning it.
- Do not use hard or pointed objects to operate the touch panel.
- Do not use paint thinner, organic solvents, or a strong acid compound to clean the unit.

**Failure to follow these instructions can result in equipment damage.**

When this product gets dirty, soak a soft cloth in water with a neutral detergent, wring the cloth tightly and wipe this product.

## Periodic Check Points

### Operation Environment

- Is the operating temperature within the allowable range? (*see page 32*)
- Is the operating humidity within the specified range? (*see page 32*)
- Is the operating atmosphere free of corrosive gases?

When this product is inside a panel, the ambient environment refers to the interior of the panel.

### Electrical Specifications

Is the input voltage appropriate? (*see page 31*)

- Are all power cords and cables connected properly? Are there any loose cables?
- Are all mounting brackets holding the unit securely?
- Are there scratches or traces of dirt on the installation gasket or Panel Cutout Adapter?

### Unit Disposal

When disposing this product, dispose it in a manner appropriate to, and in accordance with, your country's industrial machinery disposal/recycling standards.

## Replacing the Installation Gasket

### Introduction

The installation gasket provides protection against dust and moisture.

### ***NOTICE***

#### **GASKET AGING**

- Inspect the gasket periodically as required by your operating environment.
- Change the gasket at least once a year, or as soon as scratches or dirt become visible.

**Failure to follow these instructions can result in equipment damage.**

### Installing the Installation Gasket

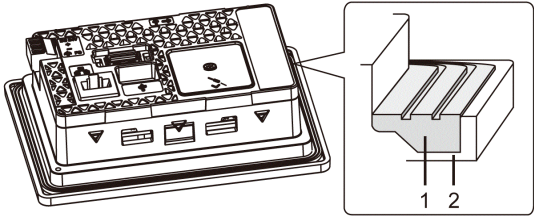
Stage	Description
1	Place this product on a flat, level surface, with the display face pointing down.
2	Remove the gasket from this product.
3	<p>Attach the new gasket to this product.                      Insert the installation gasket into the bezel's groove so that the installation gasket's groove sides are vertical.</p> <div style="text-align: center;">  </div> <p>1 Installation gasket                      2 Bezel groove</p>

The gasket must be inserted correctly into the groove for moisture resistance for this product.

### **⚠ CAUTION**

#### **EQUIPMENT DAMAGE**

Be careful not to stretch the gasket unnecessarily.

**Failure to follow these instructions can result in injury or equipment damage.**

## Replacing the Battery in the RTC Battery Set

### Introduction

RTC Battery Set (model number: PFXZGPRTC1) provides system date and time information and supports related functions requiring a real-time clock. To keep time continuity when power is off, a non-rechargeable but replaceable lithium battery is provided with the RTC Battery Set.

**NOTE:** Replacing the battery initializes the clock data.

### DANGER

#### HAZARD OF ELECTRIC SHOCK, EXPLOSION, OR ARC FLASH

- Remove all power from the device before removing any covers or elements of the system, and prior to installing or removing any accessories, hardware, or cables.
- Unplug the power cable from both this product and the power supply.
- Always use a properly rated voltage sensing device to confirm power is off.
- Replace and secure all covers or elements of the system before applying power to this product.
- Use only the specified voltage when operating this product. This product is designed to use 12 to 24 Vdc. Always check whether your device is DC powered before applying power.

**Failure to follow these instructions will result in death or serious injury.**

### DANGER

#### EXPLOSION, FIRE, OR CHEMICAL HAZARD

Follow these instructions for the lithium batteries:

- Use this product's replacement battery only.
- Protect battery from any potential short circuit.
- Recycle or properly dispose of used batteries.
- Do not recharge, disassemble or heat above 80 °C (176 °F).
- Use your hands or insulated tools to remove or replace the battery.
- Maintain proper polarity when inserting and connecting a new battery.

**Failure to follow these instructions will result in death or serious injury.**

### *NOTICE*

#### LOSS OF DATA

- Replace the battery regularly every five years after you purchase the RTC Battery Set.
- Allow only qualified personnel to change the battery.

**Failure to follow these instructions can result in equipment damage.**

### Replacing the Battery

Use only the replacement battery (model number: PFXZGEBT1).

Step	Action
1	Disconnect the power supply from this product.
2	Touch the housing or ground connection to discharge any electrostatic charge from your body.
3	Place this product on a flat, level surface, with the rear side pointing up.

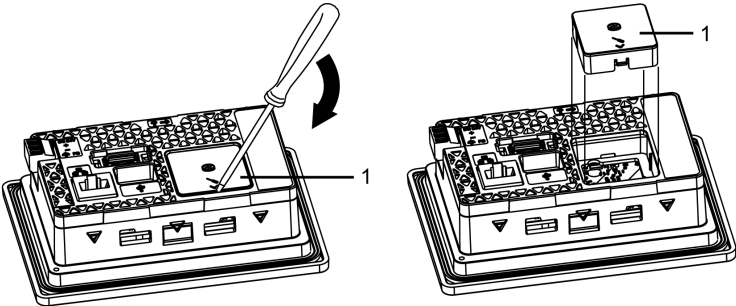
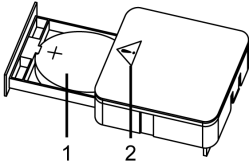
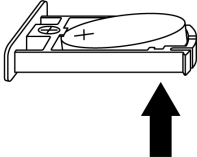
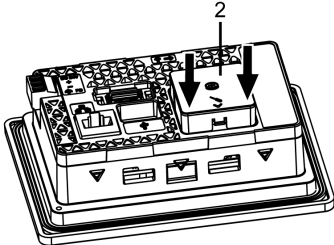
Step	Action
4	<p>Remove the RTC Battery Set on this product using a flat-blade screwdriver as illustrated:</p>  <p>1 RTC Battery Set</p>
5	<p>Pull out the tray of the RTC Battery Set.</p>  <p>1 Battery 2 Safety alert symbol (see the safety messages on the previous page)</p>
6	<p>Remove the spent battery from the tray by touching the battery from the bottom.</p> 
7	<p>Put the new battery on the tray in accordance with the polarity markings in the tray and on the battery.</p>
8	<p>Close the tray.</p>
9	<p>Insert the RTC battery horizontal with the product, and push the points indicated by the arrows until the battery clicks into the product.</p>  <p>2 RTC Battery Set</p>
10	<p>Reconnect the power supply to this product.</p> <p><b>NOTE:</b> After reconnecting the power supply, set up the clock again. Refer to your screen editing software manual on how to set up the clock.</p>



## Replacing the Backlight

Not user replaceable. When replacement is required, contact customer support.

## After-sales Service

### Information

For details on after-sales service, refer to our website at

<http://www.pro-face.com/trans/en/manual/1001.html>