

**Pro-face**

by Schneider Electric

# GP-4521T/GP-4621T Installation Guide

A decorative graphic consisting of two thick, curved lines that sweep across the bottom right portion of the page. The upper line is dark grey, and the lower line is a lighter shade of grey. Both lines curve from the bottom left towards the right, ending near the top right corner.

Please read the “Warning/Caution Information” on the attached sheet before using the product.

## Safety Information

Important Information.....	5
----------------------------	---

## Overview

Model Numbers.....	7
Global Code.....	7
Package Contents.....	8
About the Manual.....	8

## Parts Identification and Functions

Parts Identification.....	9
LED Indications.....	10

## Specifications

Electrical Specifications.....	11
Environmental Specifications.....	12

## Interface

Interface Caution.....	13
Serial Interface.....	13

## Installation

Panel Cutout Dimensions.....	16
Installation Requirements.....	16
Installation Procedure.....	19

## Wiring

Wiring.....	22
-------------	----

## Connecting to the USB Interface

USB Cable Clamp.....	29
----------------------	----

## Maintenance

Cleaning the GP unit.....	31
Replacing the Installation Gasket.....	31
Replacing the Battery.....	32

---

---

## Standards

---

Standards.....	34
----------------	----

## Important Information

### Notice

Read these instructions carefully, and look at the equipment to become familiar with the device before trying to install, operate, or maintain it. The following special messages may appear throughout this documentation or on the equipment to warn of potential hazards or to call attention to information that clarifies or simplifies a procedure.



The addition of this symbol to a "Danger" or "Warning" safety label indicates that an electrical hazard exists which will result in personal injury if the instructions are not followed.



This is the safety alert symbol. It is used to alert you to potential personal injury hazards. Obey all safety messages that follow this symbol to avoid possible injury or death.

### **DANGER**

**DANGER** indicates a hazardous situation which, if not avoided, **will result in** death or serious injury.

### **WARNING**

**WARNING** indicates a hazardous situation which, if not avoided, **could result in** death or serious injury.

### **CAUTION**

**CAUTION** indicates a hazardous situation which, if not avoided, **could result in** minor or moderate injury.

### **NOTICE**

**NOTICE** is used to address practices not related to physical injury.

**PLEASE NOTE**

Electrical equipment should be installed, operated, serviced, and maintained only by qualified personnel. No responsibility is assumed by Schneider Electric for any consequences arising out of the use of this material.

A qualified person is one who has skills and knowledge related to the construction and operation of electrical equipment and its installation, and has received safety training to recognize and avoid the hazards involved.

If the equipment is used in a manner not specified by the manufacturer, the protection provided by the equipment may be impaired.

## Model Numbers

Series		Model name	Model number <sup>*1</sup>
GP4000 Series	GP-4500 Series	GP-4521T	PFXGP4521TAA
	GP-4600 Series	GP-4621T	PFXGP4621TAA
			PFXGP4621TAD

\*1 Includes models with additional alphanumeric characters at the end of the model number.

## Global Code

A global code is assigned to every Pro-face product as a universal model number.

For more information on product models and their matching global codes, please refer to the following URL.

<http://www.pro-face.com/trans/en/manual/1003.html>

---

## Package Contents

---

The following items are included in the package. Before using this product, please confirm that all items listed here are present.

1

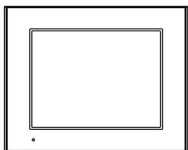

2



3

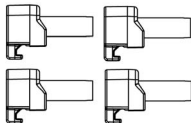

4

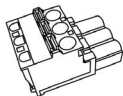

5

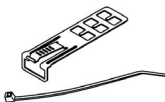

- 1 GP-4521T or GP-4621T: 1
- 2 Installation gasket: 1 (attached to this product)
- 3 Installation fasteners: 4
- 4 DC power supply connector: 1 (DC model only)
- 5 USB cable clamp Type A: 1 set (1 clip and 1 tie)
- 6 GP-4521T/GP-4621T Installation Guide (this guide): 1
- 7 Warning/Caution information: 1

This product has been carefully packed, with special attention to quality. However, should you find anything damaged or missing, please contact your local distributor immediately.

---

## About the Manual

---

This manual describes wiring and installation procedures. For more detailed information, refer to the GP4000 Series Hardware Manual.

You can download the manual from our website at <http://www.pro-face.com/trans/en/manual/1001.html>.

## Parts Identification

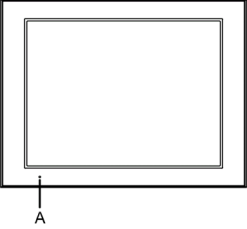
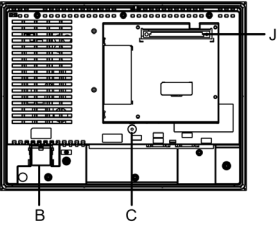
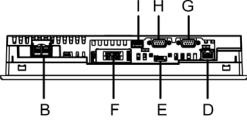
Front	
Rear	
Bottom	

- A: Status LED (see page 10)
- B: Power input terminal block (AC model) / Power plug connector (DC model)
- C: SD card access LED (see page 10)
- D: Ethernet interface
- E: USB (mini-B) interface
- F: SD card interface cover / Replacement battery insertion cover
- G: Serial interface (COM2) (see page 15)
- H: Serial interface (COM1) (see page 14)
- I: USB (Type A) interface
- J: Video unit interface<sup>\*1</sup>



\*1 The interface is for attaching the GP3000 Series VM Unit (model number: GP3000-VM01) or GP3000 Series RGB Input Unit (model number: GP3000-RGB201) manufactured by Pro-face. For information on how to install these units, refer to the corresponding hardware manual.

## LED Indications

### Status LED

Color	Indicator	Operation mode (drawing)	Logic execution mode (when logic is enabled) <sup>*1</sup>
Green	ON	Offline	-
		In operation	RUN
	Flashing	In operation	STOP
Orange	Flashing	Software starting up	
Red	ON	Power is turned ON.	
	Flashing	In operation	Major Error
LED fade (Green) <sup>*1</sup>	ON	The "Backlight Control" is set to Standby Mode and the screen has gone blank.	
-	OFF	Power is turned OFF.	

\*1 Make sure your screen editing software supports the function.

### SD Card access LED

Color	Indicator	Description
Green (Active)	ON	SD card is inserted.
	OFF	SD card is not inserted or is not detected.

### Ethernet LED

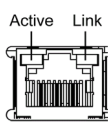
	Color	Indicator	Description
	Green (Active)	Flashing	Data transmission is occurring.
		OFF	No data transmission
	Green (Link)	ON	Data transmission is available in 10BASE-T/100BASE-TX.
		OFF	No connection or error

## Electrical Specifications

		DC model	AC model	
Power supply	Rated input voltage	24 Vdc	100...240 Vac	
	Input voltage limits	19.2...28.8 Vdc	85...264 Vac <sup>*1</sup>	
	Rated frequency	-	50/60 Hz	
	Rated frequency range	-	47...63 Hz	
	Voltage drop	10 ms or less	1 cycle or less (Voltage drop interval must be 1 second or more)	
	Power consumption	Maximum power consumption	24 W or less	100 Vac: 56 VA or less 240 Vac: 77 VA or less
		When power is not supplied to external devices	12 W or less	100 Vac: 31 VA or less 240 Vac: 44 VA or less
		Backlight OFF (Standby mode)	7 W or less	100 Vac: 19 VA or less 240 Vac: 30 VA or less
		Backlight dimmed (Brightness: 20%)	8 W or less	100 Vac: 22 VA or less 240 Vac: 32 VA or less
	In-rush current	30 A or less		
Voltage endurance	1,000 Vac, 20 mA for 1 minute (between charging and FG terminals)	1,500 Vac, 20 mA for 1 minute (between charging and PE terminals)		
Insulation resistance	500 Vdc, 10 MΩ or more (between charging and PE/FG terminals)			
Over voltage category	-	II		

\*1 The UL certified range is 90 to 264 Vac.

## Environmental Specifications

Physical environment	Ambient air temperature	0...55 °C (32...131 °F) <sup>*1</sup>
	Storage temperature	-20...60 °C (-4...140 °F)
	Ambient air and storage humidity	10...90% RH (non-condensing, wet bulb temperature 39 °C [102.2 °F] or less)
	Dust	0.1 mg/m <sup>3</sup> (10 <sup>-7</sup> oz/ft <sup>3</sup> ) or less (non-conductive levels)
	Pollution degree	For use in Pollution Degree 2 environment
	Atmospheric pressure (operating altitude)	800...1,114 hPa (2,000 m [6,561 ft] or lower)

\*1 Ambient air temperature of the video unit is 0 to 50 °C (32 to 122 °F).

## Interface Caution

Use only the SELV (Safety Extra-Low Voltage) circuit to connect the COM, USB, and LAN interfaces.

### DANGER

#### ELECTRIC SHOCK AND FIRE

When using the SG terminal to connect an external device to the GP unit:

- Verify that a short-circuit loop is not created when you set up the system.
- Connect the #5 SG terminal to remote equipment when the host (PLC) unit is not isolated. Connect the #5 SG terminal to a known reliable ground connection to reduce the risk of damaging the circuit.

**Failure to follow these instructions will result in death or serious injury.**

## Serial Interface

For information on how to connect controllers and other types of equipment, refer to the corresponding device driver manual of your screen editing software.

The serial interface is not isolated. The SG (signal ground) and the FG (functional ground) terminals are connected inside the GP unit.

### CAUTION

#### LOSS OF COMMUNICATION

- All connections to the communication ports must not put excessive stress on the ports.
- Securely attach communication cables to the panel wall or cabinet.

**Failure to follow these instructions can result in injury or equipment damage.**

**NOTE :** Use within the rated current.

**RS-232C (COM1)**

D-Sub 9 pin plug connector via an RS-232C cable.

Pin number	RS-232C		
	Signal name	Direction	Meaning
1	CD	Input	Carrier detect
2	RD(RXD)	Input	Receive data
3	SD(TXD)	Output	Send data
4	ER(DTR)	Output	Data terminal ready
5	SG	–	Signal ground
6	DR(DSR)	Input	Data set ready
7	RS(RTS)	Output	Request to send
8	CS(CTS)	Input	Send possible
9	CI(RI)/VCC	Input/–	Called status display +5 V $\pm$ 5% output 0.25 A <sup>*1</sup>
Shell	FG	–	Frame ground (common with SG)

\*1 You can switch pin #9 between RI and VCC via software. To prevent damage or a unit malfunction, use only the rated current.

Interfit bracket is #4-40 (UNC)

Recommendations:

- Cable Connector: XM3D-0921 manufactured by OMRON Corporation.
- Cable Cover: XM2S-0913 manufactured by OMRON Corporation.
- Jack Screw (#4-40 UNC): XM2Z-0073 manufactured by OMRON Corporation.

**RS-422/485 (COM2)**

D-Sub 9 pin plug connector via an RS-422/485 cable.

Pin number	RS-422/RS-485		
	Signal name	Direction	Meaning
1	RDA	Input	Receive data A (+)
2	RDB	Input	Receive data B (-)
3	SDA	Output	Send data A (+)
4	ERA	Output	Data terminal ready A (+)
5	SG	-	Signal ground
6	CSB	Input	Send possible B (-)
7	SDB	Output	Send data B (-)
8	CSA	Input	Send possible A (+)
9	ERB	Output	Data terminal ready B (-)
Shell	FG	-	Frame ground (common with SG)

Interfit bracket is #4-40 (UNC)

Recommendations:

- Cable Connector: XM3D-0921 manufactured by OMRON Corporation.
- Cable Cover: XM2S-0913 manufactured by OMRON Corporation.
- Jack Screw (#4-40 UNC): XM2Z-0073 manufactured by OMRON Corporation.

## Panel Cutout Dimensions

Based on the panel cutout dimensions, open a mount hole on the panel.

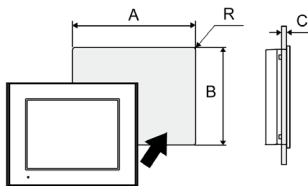

GP-4521T

A	B	C	R
259 $^{+1}_{-0}$ mm (10.2 $^{+0.04}_{-0}$ in)	201 $^{+1}_{-0}$ mm (7.91 $^{+0.04}_{-0}$ in)	1.6...5 mm (0.06...0.2 in)	3 mm (0.12 in) maximum

GP-4621T

A	B	C	R
301.5 $^{+1}_{-0}$ mm (11.87 $^{+0.04}_{-0}$ in)	227.5 $^{+1}_{-0}$ mm (8.96 $^{+0.04}_{-0}$ in)	1.6...5 mm (0.06...0.2 in)	3 mm (0.12 in) maximum

## Installation Requirements

This product is designed for use on flat surfaces of Type 1, Type 4X (Indoor Use Only), Type 13 Enclosure or IP65F.

Be aware of the following when building this product into an end-use product:

- The rear face of this product is not approved as an enclosure. When building this product into an end-use product, be sure to use an enclosure that satisfies standards as the end-use product's overall enclosure.
- Install this product in an enclosure with mechanical rigidity.
- This product is not designed for outdoor use. UL certification obtained is for indoor use only.
- Install and operate this product with its front panel facing outward.

### NOTE :

- IP65F is not part of the UL certification.
- The necessary torque to fasten the screw of the enclosed installation fasteners is 0.5 N·m (4.4 lb-in).

Check that the installation wall or cabinet surface is flat, in good condition and has no jagged edges. Metal reinforcing strips may be attached to the inside of the wall, near the panel cutout, to increase its rigidity.

Decide on the thickness of the enclosure wall, based on the level of strength required: 1.6 to 5 mm (0.06 to 0.2 in).

Even if the installation wall thickness is within the recommended range for the panel cutout dimensions, depending on wall's material, size, and installation location of this product and other devices, the installation wall could warp. To prevent warping, the installation surface may need to be strengthened.

Check that the ambient air temperature and ambient humidity are within their designated ranges (see page 12). When installing the GP unit in a cabinet or enclosure, consider the surrounding air temperature for both the internal temperature and external temperature..

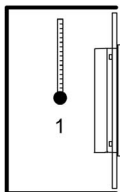

- 1 Cabinet interior
- 2 Panel face

Be sure that heat from surrounding equipment does not cause the GP unit to exceed its standard operating temperature.

When mounting the GP unit vertically, ensure that the left side of the unit faces up. In other words, the power connector or power terminal block should be at the bottom.

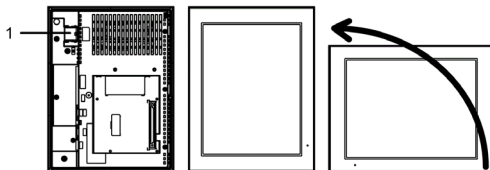

- 1 Power connector or power terminal block

**NOTE :** For a vertical mounting, make sure your screen editing software supports the function.



## Installation

When installing this product in a slanted position, the GP unit face should not incline more than  $30^{\circ}$ .

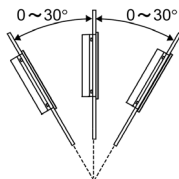

When installing this product in a slanted position with an incline more than  $30^{\circ}$ , the ambient temperature must not exceed  $40^{\circ}\text{C}$  ( $104^{\circ}\text{F}$ ). You may need to use forced air cooling (fan, A/C) to ensure the ambient operating temperature is  $40^{\circ}\text{C}$  or less ( $104^{\circ}\text{F}$  or less).

For easier maintenance, operation and improved ventilation, install this product at least 100 mm (3.94 in) away from adjacent structures and other equipment as shown in the following illustration:

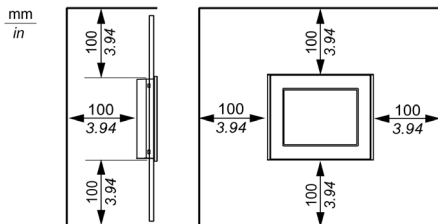

## Installation Procedure

### NOTICE

#### EQUIPMENT DAMAGE

Keep GP unit stabilized in the panel cutout while you are installing or removing the screw fasteners.

**Failure to follow these instructions can result in equipment damage.**

### Installing to the Panel

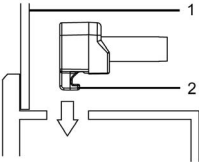
Step	Action
1	Place the GP unit on a clean and level surface with the screen facing down.
2	Check that the GP unit's gasket is seated securely into the bezel's groove, which runs around the perimeter of the display panel frame. <b>NOTE :</b> Always use the installation gasket, since it absorbs vibration in addition to repelling water. For the procedure on replacing the installation gasket, refer to "Replacing the Installation Gasket" (see page 31).
3	Based on the GP unit's panel cutout dimensions (see page 16), open a mount hole on the panel and attach the GP unit to the panel from the front side.
4	Insert the hook of installation fasteners into the GP unit's insertion slots on the top and bottom sides. If the fasteners are not correctly attached, the GP unit may shift or fall out.  1 Panel 2 Hook

## Installation

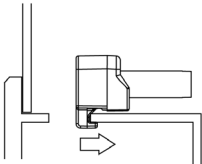
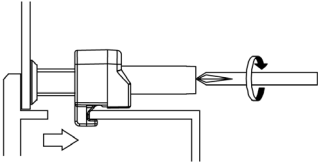
5	<p>Slide the fasteners to the back.</p>  <p>The diagram shows a cross-section of a component with a fastener being moved from its current position to the back. A grey arrow points to the right, indicating the direction of movement.</p>
6	<p>Use a Phillips screwdriver to tighten each fastener screw and secure the GP unit in place. The necessary torque is 0.5 N•m (4.4 lb-in).</p>  <p>The diagram shows a Phillips screwdriver being used to tighten a screw into a fastener. A grey arrow points to the right, indicating the direction of the screwdriver's handle.</p>

**NOTICE****BROKEN ENCLOSURE**

- Do not exert more than 0.5 N•m (4.4 lb-in) of torque when tightening the fastener's screws.
- For use on a flat surface of a Type 1, Type 4X (Indoor Use Only) or Type 13 Enclosure.

**Failure to follow these instructions can result in equipment damage.**

## Removing from the Panel

Step	Action
1	Loosen the installation fasteners (4) from the GP unit.
2	Remove the GP unit slowly from the panel while pressing the projections on the top of the GP unit.

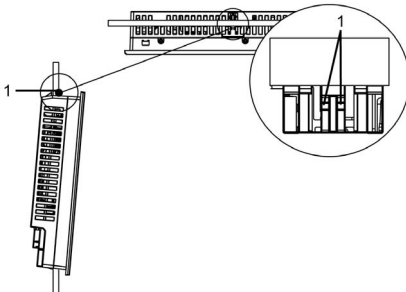

1 Projection

**Note :**

- You could damage the GP unit if you try and remove it without holding down the projections.
- Watch your fingers so they do not get caught when holding down the projections.

## ⚠ CAUTION

### RISK OF INJURY

Do not drop the GP unit when you remove it from the panel.

- Hold this product in place after removing the fasteners.
- Use both hands.

**Failure to follow these instructions can result in injury or equipment damage.**

---

**Wiring**

---

 **DANGER****HAZARD OF ELECTRIC SHOCK, EXPLOSION OR ARC FLASH**

- Remove all power from the device before removing any covers or elements of the system, and prior to installing or removing any accessories, hardware, or cables.
- Remove power before wiring this product's power terminals.
- Always use a properly rated voltage sensing device to confirm power is off.
- Replace and secure all covers or elements of the system before applying power to this product.
- Use only the specified voltage when operating this product. DC model is designed to use 24 Vdc. Always check whether your device is DC powered before applying power.
- Since this product is not equipped with a power switch, be sure to connect a power switch to the power supply.
- Be sure to ground this product's PE/FG terminal.

**Failure to follow these instructions will result in death or serious injury.**

**NOTE :**

- The SG (signal ground) and PE (protective earth)/FG (functional ground) terminals are connected internally in the GP unit.
- When the PE/FG terminal is connected, be sure the wire is grounded. Not grounding the GP unit can result in excessive electromagnetic interference (EMI). Grounding is required to meet EMC level immunity.

## AC Power Cord Preparation

- To prevent a short circuit caused by loose screws, use a crimp-type terminal with an insulating sleeve.
- For power cord, use copper wire rated for 75 °C (167 °F) or higher.

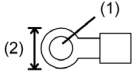
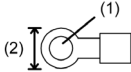
	AC power cord	Grounding wire
Power cord	Double-insulated wire 0.75 to 3.5 mm <sup>2</sup> (AWG 18-12)	0.75 to 3.5 mm <sup>2</sup> (AWG 18-12)
Recommended ring terminal	J.S.T Mfg. Co., Ltd Compatible: V1.25-M4 (AWG 18-16) V2-P4 (AWG 16-14) V5.5-S4 (AWG 14-12)   (1) $\phi 4.3$ mm (0.17 in) or more (2) Less than 7.2 mm (0.28 in)	J.S.T Mfg. Co., Ltd Compatible: V1.25-M4 (AWG 18-16) V2-P4 (AWG 16-14) V5.5-S4 (AWG 14-12)   (1) $\phi 4.3$ mm (0.17 in) or more (2) Less than 7.2 mm (0.28 in)

## How to connect the AC Power Cord

Step	Action
1	Confirm the power cord is not connected to the power supply.
2	Open the terminal strip's clear plastic cover.

- 3 Remove screws from the L, N, and PE (protective earth) terminals. Attach the ring terminals and reinsert the screws. Check each wire to make sure the connections are correct.

**Note :** The necessary torque is as follow.

- Terminal block: 1.4 N•m (12.4 lb-in)
- PE terminal: 1.4 N•m (12.4 lb-in)

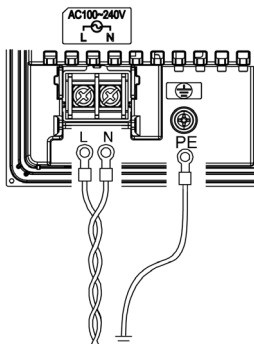

- 4 Close the terminal strip's clear plastic cover.

## DC Power Cord Preparation

- Make sure the ground wire is either the same or heavier gauge than the power wires.
- Do not use aluminum wires in the power supply's power cord.
- To prevent the possibility of a terminal short, use a pin terminal that has an insulating sleeve.
- If the ends of the individual wires are not twisted correctly, the wires may create a short circuit.
- The conductor type is solid or stranded wire.
- For power cord, use copper wire rated for 75 °C (167 °F) or higher.

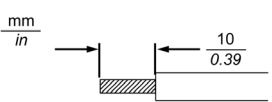
Power cord diameter	0.75...2.5 mm <sup>2</sup> (AWG 18...13) <sup>*1</sup>
Conductor type	Solid or stranded wire
Conductor length	
Recommended driver <sup>*2</sup>	SZS 0.6x3.5 (1205053)
Recommended pin terminals <sup>*2</sup>	3201288 AI 0,75-10 GY 3200182 AI 1 -10 RD 3200195 AI 1,5 -10 BK 3202533 AI 2,5 -10 BU
Recommended pin terminal crimp tool <sup>*2</sup>	CRIMPFOX 6

\*1 For UL compatibility, use AWG 14 or AWG 13.

\*2 Items are made by Phoenix Contact.

## DC Power Supply Connector Specifications

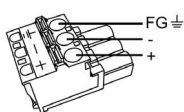
	<b>Connection</b>	<b>Wire</b>
	+	24 Vdc
	-	0 Vdc
	FG	Grounded terminal connected to the panel chassis.

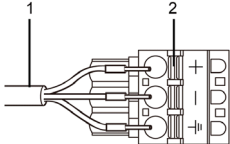

## How to Connect the DC Power Cord

Step	Action
1	Confirm the power cord is not connected to the power supply.
2	Check the rated voltage, and remove the "DC24V" sticker on the DC power supply connector.
3	Remove 10 mm (0.39 in) of the vinyl membrane off the ends of the power cord wires.
4	Push the Opening button with a small and flat screwdriver to open the desired pin hole.
5	Insert each pin terminal into its corresponding holder. Release the Opening button to clamp the pin in place. <div style="text-align: center;">  </div> <p>1 Power cable 2 Opening button</p> <p>When using stranded wire, do not short with neighboring wires.</p>
6	After inserting all three pins, insert the DC power supply connector into the power connector on the GP unit.

**NOTE :** Do not solder the wire directly to the power receptacle pin.

## Wiring Precautions

Use a maximum of 20 A branch circuit protective device for AC input.

Use SELV (Safety Extra-Low Voltage) circuit and LIM (Limited Energy) circuit for DC input.

### DANGER

#### SHORT CIRCUIT, FIRE, OR UNINTENDED EQUIPMENT OPERATION

Avoid excessive force on the power cable to prevent accidental disconnection

- Securely attach power cables to an installation panel or cabinet.
- Use the necessary torque to tighten this product terminal block screws.
- Install and fasten the GP unit on installation panel or cabinet prior to connecting power supply and communication lines.

**Failure to follow these instructions will result in death or serious injury.**

#### Improving Noise/Surge Resistance

- The GP unit's power supply cord should not be bundled with or kept close to main circuit lines (high voltage, high current), power lines, or input/output lines, and their various systems should be kept separate. When power lines cannot be wired via a separate system, use shielded cables for input/output lines.
- Make the power cord as short as possible, and be sure to twist the ends of the wires together (i.e. twisted pair cabling) from close to the power supply unit.
- If there is an excess amount of noise on the power supply line, connect a noise reducing transistor before turning on the power.
- Connect a surge absorber to handle power surges. Be sure to ground the surge absorber (E1) separately from the GP unit (E2).

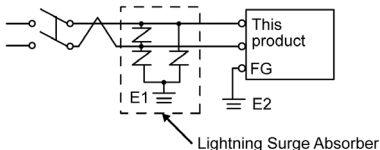

## Grounding

- Check that the grounding resistance is 100  $\Omega$  or less.\*1
- The PE (protective earth)/FG (functional ground) wire should have a cross sectional area greater than 2 mm<sup>2</sup> (AWG 14)\*1. Create the connection point as close to the GP unit as possible, and make the wire as short as possible. When using a long grounding wire, replace the thin wire with a thicker wire, and place it in a duct.

\*1 Observe local codes and standards.

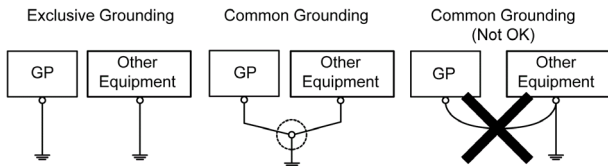

## Short Circuit Prevention

- The SG (signal ground) and PE (protective earth)/FG (functional ground) terminals are connected internally in the GP unit. When connecting the SG line to another device, be sure that no shorting loops are formed.

## USB Cable Clamp

When using a USB device, attach a USB cable clamp to the USB interface to prevent the USB cable from being disconnected.

### Attaching the USB cable clamp

**NOTE :** Watch your fingers. The edge of the clip is sharp.

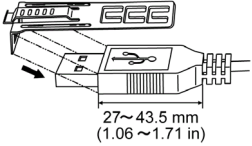
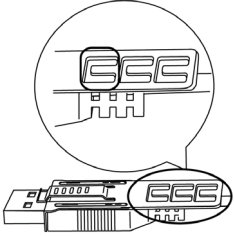
Step	Action
1	<p>Mount the clip to the USB mark  connector shell so that it overlaps. The clip matches the 27 to 43.5 mm (1.06 to 1.71 in) length of the USB connector.</p> 
2	<p>Align the clip and the USB cable connector shell. Adjust the position of the holes where the clip is attached. To ensure stability, select the clip-hole position that is closest to the base of the connector shell.</p> 

## Connecting to the USB Interface

- 3 As shown, pass the tie through the clip hole. Next, turn the tie and pass it through the head so that the USB cable can pass through the center of the tie loop. The clip is now attached to the USB cable.

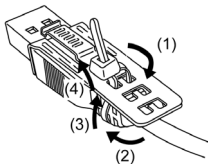
**NOTE :**

- Check the direction of the head beforehand. Make sure the USB cable is through the center of the tie loop and that the tie can pass through the head.
- Tie provided can be substituted with optional PFXZCBCLUSA1, or other commercially available ties with 4.8 mm (0.19 in) width and 1.3 mm (0.05 in) thickness.

- 4 While pressing the grip on the clip, insert the cable from step 3 all the way into the USB (Type A) interface. Make sure that the clip tab is secured to the USB cable attached to the GP unit.

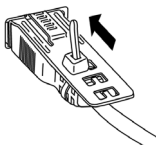

## Removing the USB cable clamp

Step	Action
1	Remove the USB cable while pushing the grip section of the clip.

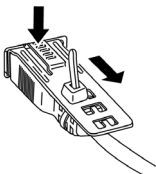

## Cleaning the GP unit

### **NOTICE**

#### **EQUIPMENT DAMAGE**

- Power off the unit before cleaning it.
- Do not use hard or pointed objects to operate the touch panel.
- Do not use paint thinner, organic solvents, or a strong acid compound to clean the unit.

**Failure to follow these instructions can result in equipment damage.**

When the unit gets dirty, soak a soft cloth in water with a neutral detergent, wring the cloth tightly and wipe this product.

## Replacing the Installation Gasket

The installation gasket provides protection against dust and moisture.

### **NOTICE**

#### **GASKET AGING**

- Inspect the gasket periodically as required by your operating environment.
- Change the gasket at least once a year, or as soon as scratches or dirt become visible.

**Failure to follow these instructions can result in equipment damage.**

Step	Action
1	Place the GP unit on a flat, level surface, with the display face pointing down.
2	Remove the gasket from the GP unit.
3	<p>Attach the new gasket to the GP unit. First, insert the gasket into the 4 corners of the installation groove. Then, insert the rest of the gasket into the installation groove.</p> <ul style="list-style-type: none"> <li>• Position the gasket in the installation groove so that the gasket seam is at the bottom of the GP unit.</li> <li>• The upper surface of the gasket should protrude approximately 2.5 mm (0.1 in) from the groove. Check the gasket is inserted correctly before installing the GP unit into a panel.</li> </ul>

The gasket must be inserted correctly into the groove for moisture resistance for the GP unit.

## Replacing the Battery

The primary battery is non-rechargeable, and is used for data backup of memory and the internal clock. If the battery is depleted, the backup data is lost.

### **DANGER**

#### **HAZARD OF ELECTRIC SHOCK, EXPLOSION OR ARC FLASH**

- Follow the procedures step by step to replace the battery correctly and safely.
- Before replacing the battery, turn OFF the GP unit's power.

**Failure to follow these instructions will result in death or serious injury.**

### **DANGER**

#### **EXPLOSION, FIRE, OR CHEMICAL HAZARD**

- Use this product's replacement battery only.
- Do not cause a short circuit.
- Recycle or properly dispose of used batteries.

**Failure to follow these instructions will result in death or serious injury.**

One month before the battery is completely depleted, a message will appear to indicate it is time to replace the battery.

### **NOTICE**

#### **LOSS OF DATA**

- Replace the battery within one month after the message appears.
- Complete replacing the battery within ten minutes of shutting down the GP unit.
- Replace the battery regularly every five years after you purchase the GP unit.
- Allow only qualified personnel to change the battery.

**Failure to follow these instructions can result in equipment damage.**

**NOTE :** The battery replacement time (within a month after the message appears) is only a guideline.

Use only the replacement battery (model number: PFXZCBBT1).

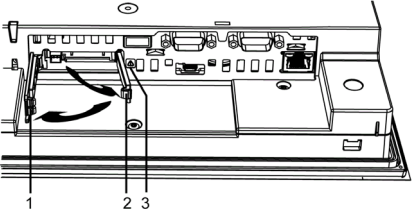
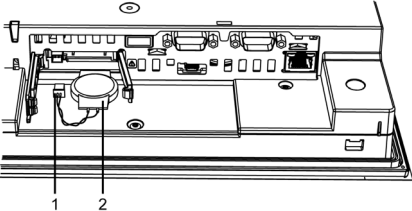
Step	Action
1	Disconnect the power supply from the GP unit.
2	Touch the housing or ground connection (not the power supply) to discharge any electrostatic charge from your body.
3	<p>Open the SD card interface cover by pressing its tab. Next, open the replacement battery insertion cover by pressing its tab.</p>  <p>1 SD card interface cover 2 Replacement battery insertion cover 3 Safety alert symbol (See the safety messages on page 32)</p>
4	<p>Remove the primary battery and connector.</p>  <p>1 Connector 2 Primary battery</p>
5	Insert the replacement battery and connector all the way. Either side of the battery can face top or bottom.
6	<p>First close the replacement battery cover, then close the SD card interface cover.</p> <p><b>NOTE :</b> Insert the battery connector cables completely inside the enclosure.</p>



---

## Standards

---

For information on certifications and standards, such as certified models and certificates, see the product markings or the following URL:

<http://www.pro-face.com/trans/en/manual/1002.html>

### Inquiry

Do you have any questions about difficulties with your unit?

Please access our site any time that you need help with a solution.

[\*\*http://www.pro-face.com/trans/en/manual/1001.html\*\*](http://www.pro-face.com/trans/en/manual/1001.html)

### Note

Please be aware that SEJHD shall not be held liable by the user for any damages, losses, or third party claims arising from the uses of this product.