

# Altivar Machine ATV320

## Variable Speed Drives for Asynchronous and Synchronous Motors

### Installation Manual

01/2017



---

The information provided in this documentation contains general descriptions and/or technical characteristics of the performance of the products contained herein. This documentation is not intended as a substitute for and is not to be used for determining suitability or reliability of these products for specific user applications. It is the duty of any such user or integrator to perform the appropriate and complete risk analysis, evaluation and testing of the products with respect to the relevant specific application or use thereof. Neither Schneider Electric nor any of its affiliates or subsidiaries shall be responsible or liable for misuse of the information contained herein. If you have any suggestions for improvements or amendments or have found errors in this publication, please notify us.

No part of this document may be reproduced in any form or by any means, electronic or mechanical, including photocopying, without express written permission of Schneider Electric.

All pertinent state, regional, and local safety regulations must be observed when installing and using this product. For reasons of safety and to help ensure compliance with documented system data, only the manufacturer should perform repairs to components.

When devices are used for applications with technical safety requirements, the relevant instructions must be followed.

Failure to use Schneider Electric software or approved software with our hardware products may result in injury, harm, or improper operating results.

Failure to observe this information can result in injury or equipment damage.

© 2017 Schneider Electric. All Rights Reserved.

---

# Table of Contents

---



	<b>Safety Information</b> .....	<b>5</b>
	<b>About the Book</b> .....	<b>9</b>
<b>Chapter 1</b>	<b>Introduction</b> .....	<b>11</b>
	Verifying the Absence of Voltage .....	<b>12</b>
	Drive Overview .....	<b>13</b>
	Accessories and Options .....	<b>16</b>
<b>Chapter 2</b>	<b>Technical Data</b> .....	<b>19</b>
	Environmental Conditions .....	<b>20</b>
	Dimensions and Weights .....	<b>21</b>
	Drive Ratings .....	<b>30</b>
<b>Chapter 3</b>	<b>Drive Mounting</b> .....	<b>33</b>
	Green Premium™ .....	<b>34</b>
	Steps for setting up the drive .....	<b>35</b>
	Initial Steps .....	<b>36</b>
	Mounting Conditions .....	<b>37</b>
	Derating Curves .....	<b>40</b>
	Mounting .....	<b>47</b>
<b>Chapter 4</b>	<b>Drive wiring</b> .....	<b>49</b>
	Wiring Instructions .....	<b>50</b>
	Cable Length Instructions .....	<b>53</b>
	Wiring Diagrams .....	<b>54</b>
	Operation on an IT System .....	<b>58</b>
	Disconnecting the Built-in EMC Filter .....	<b>58</b>
	Sink / Source Switch Configuration .....	<b>62</b>
	Characteristics of the Power Part Terminals .....	<b>64</b>
	Wiring the Power Part .....	<b>67</b>
	EMC plate assembly fitting .....	<b>82</b>
	Electromagnetic Compatibility .....	<b>85</b>
	Control Terminals Electrical Data .....	<b>87</b>
	Arrangement and Characteristics of Control Block Terminals and Communication and I/O Ports .....	<b>89</b>
	Wiring The Control Part .....	<b>90</b>
<b>Chapter 5</b>	<b>Checking Installation</b> .....	<b>93</b>
	Before Switching On .....	<b>93</b>
<b>Chapter 6</b>	<b>Maintenance</b> .....	<b>95</b>
	Scheduled servicing .....	<b>95</b>
<b>Glossary</b>	.....	<b>97</b>





## Important Information

### NOTICE

Read these instructions carefully, and look at the equipment to become familiar with the device before trying to install, operate, service, or maintain it. The following special messages may appear throughout this documentation or on the equipment to warn of potential hazards or to call attention to information that clarifies or simplifies a procedure.



The addition of this symbol to a “Danger” or “Warning” safety label indicates that an electrical hazard exists which will result in personal injury if the instructions are not followed.



This is the safety alert symbol. It is used to alert you to potential personal injury hazards. Obey all safety messages that follow this symbol to avoid possible injury or death.

### **DANGER**

**DANGER** indicates a hazardous situation which, if not avoided, **will result in** death or serious injury.

### **WARNING**

**WARNING** indicates a hazardous situation which, if not avoided, **could result in** death or serious injury.

### **CAUTION**

**CAUTION** indicates a hazardous situation which, if not avoided, **could result in** minor or moderate injury.

### **NOTICE**

**NOTICE** is used to address practices not related to physical injury.

### PLEASE NOTE

Electrical equipment should be installed, operated, serviced, and maintained only by qualified personnel. No responsibility is assumed by Schneider Electric for any consequences arising out of the use of this material.

A qualified person is one who has skills and knowledge related to the construction and operation of electrical equipment and its installation, and has received safety training to recognize and avoid the hazards involved.

### Qualification Of Personnel

Only appropriately trained persons who are familiar with and understand the contents of this manual and all other pertinent product documentation are authorized to work on and with this product. In addition, these persons must have received safety training to recognize and avoid hazards involved. These persons must have sufficient technical training, knowledge and experience and be able to foresee and detect potential hazards that may be caused by using the product, by changing the settings and by the mechanical, electrical and electronic equipment of the entire system in which the product is used. All persons working on and with the product must be fully familiar with all applicable standards, directives, and accident prevention regulations when performing such work.

## Intended Use

This product is a drive for three-phase synchronous, asynchronous motors and intended for industrial use according to this manual. The product may only be used in compliance with all applicable safety standard and local regulations and directives, the specified requirements and the technical data. The product must be installed outside the hazardous ATEX zone. Prior to using the product, you must perform a risk assessment in view of the planned application. Based on the results, the appropriate safety measures must be implemented. Since the product is used as a component in an entire system, you must ensure the safety of persons by means of the design of this entire system (for example, machine design). Any use other than the use explicitly permitted is prohibited and can result in hazards. Electrical equipment should be installed, operated, serviced, and maintained only by qualified personnel.

## Product Related Information

**Read and understand these instructions before performing any procedure with this drive.**

### **DANGER**

#### **HAZARD OF ELECTRIC SHOCK, EXPLOSION OR ARC FLASH**

- Only appropriately trained persons who are familiar with and understand the contents of this manual and all other pertinent product documentation and who have received safety training to recognize and avoid hazards involved are authorized to work on and with this drive system. Installation, adjustment, repair and maintenance must be performed by qualified personnel.
- The system integrator is responsible for compliance with all local and national electrical code requirements as well as all other applicable regulations with respect to grounding of all equipment.
- Many components of the product, including the printed circuit boards, operate with mains voltage. Do not touch.
- Only use properly rated, electrically insulated tools and measuring equipment.
- Do not touch unshielded components or terminals with voltage present.
- Motors can generate voltage when the shaft is rotated. Prior to performing any type of work on the drive system, block the motor shaft to prevent rotation.
- AC voltage can couple voltage to unused conductors in the motor cable. Insulate both ends of unused conductors of the motor cable.
- Do not short across the DC bus terminals or the DC bus capacitors or the braking resistor terminals.
- Before performing work on the drive system:
  - Disconnect all power, including external control power that may be present.
  - Place a **Do Not Turn On** label on all power switches related to the drive system.
  - Lock all power switches in the open position.
  - Wait 15 minutes to allow the DC bus capacitors to discharge.
  - Follow the instructions given in the chapter "Verifying the Absence of Voltage" in the installation manual of the product.
- Before applying voltage to the drive system:
  - Verify that the work has been completed and that the entire installation cannot cause hazards.
  - If the mains input terminals and the motor output terminals have been grounded and short-circuited, remove the ground and the short circuits on the mains input terminals and the motor output terminals.
  - Verify proper grounding of all equipment.
  - Verify that all protective equipment such as covers, doors, grids is installed and/or closed.

**Failure to follow these instructions will result in death or serious injury.**

Drive systems may perform unexpected movements because of incorrect wiring, incorrect settings, incorrect data or other errors.

### **WARNING**

#### **UNANTICIPATED EQUIPMENT OPERATION**

- Carefully install the wiring in accordance with the EMC requirements.
- Do not operate the product with unknown or unsuitable settings or data.
- Perform a comprehensive commissioning test.

**Failure to follow these instructions can result in death, serious injury, or equipment damage.**

Damaged products or accessories may cause electric shock or unanticipated equipment operation.

## DANGER

### ELECTRIC SHOCK OR UNANTICIPATED EQUIPMENT OPERATION

Do not use damaged products or accessories.

**Failure to follow these instructions will result in death or serious injury.**

Contact your local Schneider Electric sales office if you detect any damage whatsoever.

## WARNING

### LOSS OF CONTROL

- The designer of any control scheme must consider the potential failure modes of control paths and, for critical control functions, provide a means to achieve a safe state during and after a path failure. Examples of critical control functions are emergency stop, overtravel stop, power outage and restart.
- Separate or redundant control paths must be provided for critical control functions.
- System control paths may include communication links. Consideration must be given to the implications of unanticipated transmission delays or failures of the link.
- Observe all accident prevention regulations and local safety guidelines (1).
- Each implementation of the product must be individually and thoroughly tested for proper operation before being placed into service.

**Failure to follow these instructions can result in death, serious injury, or equipment damage.**

(1) For USA: Additional information, refer to NEMA ICS 1.1 (latest edition), Safety Guidelines for the Application, Installation, and Maintenance of Solid State Control and to NEMA ICS 7.1 (latest edition), Safety Standards for Construction and Guide for Selection, Installation and Operation of Adjustable-Speed Drive Systems.

## *NOTICE*

### DESTRUCTION DUE TO INCORRECT MAINS VOLTAGE

Before switching on and configuring the product, verify that it is approved for the mains voltage

**Failure to follow these instructions can result in equipment damage.**

The temperature of the products described in this manual may exceed 80 °C (176 °F) during operation.

## WARNING

### HOT SURFACES

- Ensure that any contact with hot surfaces is avoided.
- Do not allow flammable or heat-sensitive parts in the immediate vicinity of hot surfaces.
- Verify that the product has sufficiently cooled down before handling it.
- Verify that the heat dissipation is sufficient by performing a test run under maximum load conditions.

**Failure to follow these instructions can result in death, serious injury, or equipment damage.**

This equipment has been designed to operate outside of any hazardous location. Only install this equipment in zones known to be free of a hazardous atmosphere.

## DANGER

### POTENTIAL FOR EXPLOSION

Install and use this equipment in non-hazardous locations only.

**Failure to follow these instructions will result in death or serious injury.**





# About the Book



## At a Glance

### Document Scope

The purpose of this document is:

- to give you mechanical and electrical information related to the Altivar 320 drive,
- to show you how to install and wire this drive.

### Validity Note

Original instructions and information given in this manual have been written in English (before optional translation).

**NOTE:** The products listed in the document are not all available at the time of publication of this document online. The data, illustrations and product specifications listed in the guide will be completed and updated as the product availabilities evolve. Updates to the guide will be available for download once products are released on the market.

This documentation is valid for the Altivar Machine drive.

The technical characteristics of the devices described in this document also appear online. To access this information online:

Step	Action
1	Go to the Schneider Electric home page <a href="http://www.schneider-electric.com">www.schneider-electric.com</a> .
2	In the <b>Search</b> box type the reference of a product or the name of a product range. <ul style="list-style-type: none"><li>• Do not include blank spaces in the reference or product range.</li><li>• To get information on grouping similar modules, use asterisks (*).</li></ul>
3	If you entered a reference, go to the <b>Product Datasheets</b> search results and click on the reference that interests you. If you entered the name of a product range, go to the <b>Product Ranges</b> search results and click on the product range that interests you.
4	If more than one reference appears in the <b>Products</b> search results, click on the reference that interests you.
5	Depending on the size of your screen, you may need to scroll down to see the data sheet.
6	To save or print a data sheet as a .pdf file, click <b>Download XXX product datasheet</b> .

The characteristics that are presented in this manual should be the same as those characteristics that appear online. In line with our policy of constant improvement, we may revise content over time to improve clarity and accuracy. If you see a difference between the manual and online information, use the online information as your reference.

### Related Documents

Use your tablet or your PC to quickly access detailed and comprehensive information on all our products on [www.schneider-electric.com](http://www.schneider-electric.com)

The Internet site provides the information you need for products and solutions

- The whole catalog for detailed characteristics and selection guides
- The CAD files to help design your installation, available in over 20 different file formats
- All software and firmware to maintain your installation up to date
- A large quantity of White Papers, Environment documents, Application solutions, Specifications... to gain a better understanding of our electrical systems and equipment or automation
- And finally all the User Guides related to your drive, listed below:

Title of Documentation	Reference Number
ATV320 Getting Started	<a href="#">NVE21763</a> (English), <a href="#">NVE21771</a> (French), <a href="#">NVE21772</a> (German), <a href="#">NVE21773</a> (Spanish), <a href="#">NVE21774</a> (Italian), <a href="#">NVE21776</a> (Chinese)
ATV320 Getting Started Annex (SCCR)	<a href="#">NVE21777</a> (English)

Title of Documentation	Reference Number
ATV320 Installation manual	<a href="#">NVE41289</a> (English), <a href="#">NVE41290</a> (French), <a href="#">NVE41291</a> (German), <a href="#">NVE41292</a> (Spanish), <a href="#">NVE41293</a> (Italian), <a href="#">NVE41294</a> (Chinese)
ATV320 Programming manual	<a href="#">NVE41295</a> (English), <a href="#">NVE41296</a> (French), <a href="#">NVE41297</a> (German), <a href="#">NVE41298</a> (Spanish), <a href="#">NVE41299</a> (Italian), <a href="#">NVE41300</a> (Chinese)
ATV320 Modbus Serial Link manual (embedded)	<a href="#">NVE41308</a> (English)
ATV320 Modbus TCP - Ethernet IP manual (VW3A3616)	<a href="#">NVE41313</a> (English)
ATV320 PROFIBUS DP manual (VW3A3607)	<a href="#">NVE41310</a> (English)
ATV320 DeviceNet manual (VW3A3609)	<a href="#">NVE41314</a> (English)
ATV320 CANopen manual (VW3A3608, 618, 628)	<a href="#">NVE41309</a> (English)
ATV320 POWERLINK manual (VW3A3619)	<a href="#">NVE41312</a> (English)
ATV320 EtherCAT manual (VW3A3601)	<a href="#">NVE41315</a> (English)
ATV320 Communication Parameters	<a href="#">NVE41316</a> (English)
ATV320 Safety Functions manual	<a href="#">NVE50467</a> (English), <a href="#">NVE50468</a> (French), <a href="#">NVE50469</a> (German), <a href="#">NVE50470</a> (Spanish), <a href="#">NVE50472</a> (Italian), <a href="#">NVE50473</a> (Chinese)
BMP Synchronous Motor manual	<a href="#">0198441113981-EN</a> (English), <a href="#">0198441113982-FR</a> (French), <a href="#">0198441113980-DE</a> (German), <a href="#">0198441113984-ES</a> (Spanish), <a href="#">0198441113983-IT</a> (Italian), <a href="#">0198441113985-ZH</a> (Chinese)
ATV320 ATV Logic manual	<a href="#">NVE71954</a> (English), <a href="#">NVE71955</a> (French), <a href="#">NVE71957</a> (German), <a href="#">NVE71959</a> (Spanish), <a href="#">NVE71958</a> (Italian), <a href="#">NVE71960</a> (Chinese)
SoMove: FDT	<a href="#">SoMove FDT</a> (English, French, German, Spanish, Italian, Chinese)
ATV320: DTM	<a href="#">ATV320 DTM Library</a> (English, French, German, Spanish, Italian, Chinese)

You can download these technical publications and other technical information from our website at <http://www.schneider-electric.com/ww/en/download>

## Electronic Product Data sheet

Scan the QR code in front of the drive to get the product data sheet.

## Terminology

The technical terms, terminology, and the corresponding descriptions in this manual normally use the terms or definitions in the relevant standards.

In the area of drive systems this includes, but is not limited to, terms such as **error**, **error message**, **failure**, **fault**, **fault reset**, **protection**, **safe state**, **safety function**, **warning**, **warning message**, and so on.

Among others, these standards include:

- IEC 61800 series: Adjustable speed electrical power drive systems
- IEC 61508 Ed.2 series: Functional safety of electrical/electronic/programmable electronic safety-related
- EN 954-1 Safety of machinery - Safety related parts of control systems
- ISO 13849-1 & 2 Safety of machinery - Safety related parts of control systems
- IEC 61158 series: Industrial communication networks - Fieldbus specifications
- IEC 61784 series: Industrial communication networks - Profiles
- IEC 60204-1: Safety of machinery - Electrical equipment of machines – Part 1: General requirements

In addition, the term **zone of operation** is used in conjunction with the description of specific hazards, and is defined as it is for a **hazard zone** or **danger zone** in the EC Machinery Directive (2006/42/EC) and in ISO 12100-1.

Also see the glossary at the end of this manual.

---

# Chapter 1

## Introduction

---

### What Is in This Chapter?

This chapter contains the following topics:

Topic	Page
Verifying the Absence of Voltage	12
Drive Overview	13
Accessories and Options	16

## Verifying the Absence of Voltage

### Instructions

The DC bus voltage level is determined by measuring the voltage between the DC bus terminals PA/+ and PC/-.

The location of the DC bus terminals depends on the drive model.

Identify your drive model by referring to the nameplate of the drive. Then, refer to the chapter "Wiring the Power Part" (*see page 67*)

### DANGER

#### HAZARD OF ELECTRIC SHOCK, EXPLOSION OR ARC FLASH

- Only appropriately trained persons who are familiar with and understand the contents of this manual and all other pertinent product documentation and who have received safety training to recognize and avoid hazards involved are authorized to work on and with this drive system. Installation, adjustment, repair and maintenance must be performed by qualified personnel.
- The system integrator is responsible for compliance with all local and national electrical code requirements as well as all other applicable regulations with respect to grounding of all equipment.
- Many components of the product, including the printed circuit boards, operate with mains voltage. Do not touch.
- Only use properly rated, electrically insulated tools and measuring equipment.
- Do not touch unshielded components or terminals with voltage present.
- Motors can generate voltage when the shaft is rotated. Prior to performing any type of work on the drive system, block the motor shaft to prevent rotation.
- AC voltage can couple voltage to unused conductors in the motor cable. Insulate both ends of unused conductors of the motor cable.
- Do not short across the DC bus terminals or the DC bus capacitors or the braking resistor terminals.
- Before performing work on the drive system:
  - Disconnect all power, including external control power that may be present.
  - Place a **Do Not Turn On** label on all power switches related to the drive system.
  - Lock all power switches in the open position.
  - Wait 15 minutes to allow the DC bus capacitors to discharge.
  - Follow the instructions given in the chapter "Verifying the Absence of Voltage" in the installation manual of the product.
- Before applying voltage to the drive system:
  - Verify that the work has been completed and that the entire installation cannot cause hazards.
  - If the mains input terminals and the motor output terminals have been grounded and short-circuited, remove the ground and the short circuits on the mains input terminals and the motor output terminals.
  - Verify proper grounding of all equipment.
  - Verify that all protective equipment such as covers, doors, grids is installed and/or closed.

**Failure to follow these instructions will result in death or serious injury.**

### Procedure

Perform the following actions to verify the absence of voltage





Step	Action
1	Measure the voltage on the DC bus between the DC bus terminals (PA/+ and PC/-) using a properly rated voltmeter to verify that the voltage is less than 42 Vdc
2	If the DC bus capacitors do not discharge properly, contact your local Schneider Electric representative. Do not repair or operate the product.
3	Verify that no other voltage is present in the drive system.

## Drive Overview



### About The Drive Frame Sizes

The drive frame size first digits 1, 2, 3, 4 and 5 are related to the drive footprint. First digit is followed the letter B for the book form factor drives and by the letter C for compact form factor drives. Please note that depending on the catalog number, a drive of the same frame size may have different depth values.



### "Book" Form Factor Drives

Frame size 1B	Frame size 2B
<ul style="list-style-type: none"> <li>Single phase 200...240 V, 0.18...0.75 kW, 1/4...1 HP</li> <li>3-phase 380...500 V, 0.37...1.5 kW, 0.5...2 HP</li> </ul>	<ul style="list-style-type: none"> <li>Single phase 200...240 V, 1.1...2.2 kW, 1.5...3 HP</li> <li>3-phase 380...500 V, 2.2...4 kW, 3...5 HP</li> </ul>
	
ATV320U••M2B, U0•N4B, U1•N4B	ATV320U••M2B, U22N4B, U30N4B, U40N4B
Frame size 4B	Frame size 5B
<ul style="list-style-type: none"> <li>3-phase 380...500 V, 5.5 kW and 7.5 kW, 7.5 and 10 HP</li> </ul>	<ul style="list-style-type: none"> <li>3-phase 380...500 V, 11 kW and 15 kW, 15 and 20 HP)</li> </ul>
	
ATV320U55N4B and U75N4B	ATV320D11N4B and D15N4B

## “Compact” Form Factor Drives

Frame size 1C	Frame size 2C
<ul style="list-style-type: none"> <li>● 1-phase 200...240 V, 0.18...0.75 kW, 1/4...1 HP</li> <li>● 3-phase 200...240 V, 0.18...0.75 kW, 1/4...1 HP</li> </ul>	<ul style="list-style-type: none"> <li>● 1-phase 200...240 V, 1.1...2.2 kW, 1.5...3 HP</li> <li>● 3-phase 200...240 V, 1.1...2.2 kW, 1.5...3 HP</li> <li>● 3-phase 380...500 V, 0.37...1.5 kW, 0.5...2 HP</li> <li>● 3-phase 525...600 V, 0.75...1.5 kW, 1...2 HP</li> </ul>
	
ATV320U0•M•C (1)	ATV320U••M•C, U••N4C, U••S6C (1)
(1) ATV320U••M2C: drives for single-phase supply mains. ATV320U••M3C: drives for 3-phase supply mains	

**NOTE:** For a given frame size, there may be different depth values, details are visible in the Dimensions and Weight section ([see page 21](#))

Frame size 3C	Frame size 4C
<ul style="list-style-type: none"> <li>● 3-phase 200...240 V, 3 kW and 4 kW, up to 5 HP</li> <li>● 3-phase 380...500 V, 2.2...4 kW, up to 5 HP</li> <li>● 3-phase 525...600 V, 2.2...4 kW, up to 5 HP</li> </ul>	<ul style="list-style-type: none"> <li>● 3-phase 200...240 V, 5.5 kW and 7.5 kW, 7.5...10 HP</li> <li>● 3-phase 525...600 V, 5.5...7.5 kW, 4...10 HP</li> </ul>
	
ATV320U30M3C and U40M3C ATV320U22N4C...U40N4C ATV320U22S6C and U40S6C	ATV320U55M3C and U75M3C ATV320U55S6C and U75S6C

Frame size 5C
<ul style="list-style-type: none"> <li>● 3-phase 200...240 V, 11 kW and 15 kW, 15...20 HP</li> <li>● 3-phase 525...600 V, 11 kW and 15 kW, 15...20 HP</li> </ul>

ATV320D11M3C and D15M3C ATV320D11S6C and D15S6C

## Catalog Number Description

	<b>ATV</b>	<b>320</b>	<b>U</b>	<b>22</b>	<b>N4</b>	<b>C</b>
<b>Product Range</b>	ATV Altivar					
<b>Product Type</b>	320 Drive range					
<b>Factor for power rating</b>	<b>U</b> power x 0.1 <b>D</b> power x 1					
<b>Power rating</b>	02 - 04 - 06 - 07 - 11 - 15 - 22 - 30 - 40 - 55 - 75					
<b>Power part supply</b>	<b>M2</b> Single phase, 200 Vac (200...240 Vac) <b>M3</b> 3-phase, 200 Vac (200...240 Vac) <b>N4</b> 3-phase, 400 Vac (380...500 Vac) <b>S6</b> 3-phase, 600 Vac (525...600 Vac) <i>upcoming marketing</i>					
<b>Product Form Factor</b>	<b>B</b> "Book" form factor <b>C</b> "Compact" form factor					

NOTE: see the catalog for possible combinations.

## Nameplate example

The nameplate contains the following data:

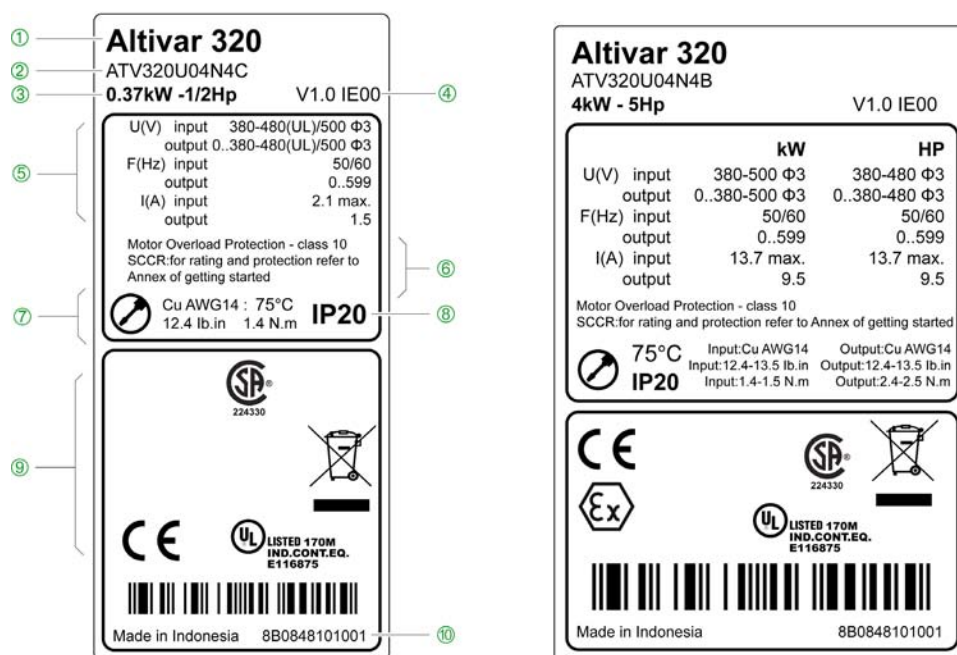

- ① Product type
- ② Catalog number
- ③ Power rating
- ④ Firmware version
- ⑤ Power part supply
- ⑥ Fuses and overload protection information
- ⑦ Power part cable information
- ⑧ Degree of protection
- ⑨ Certifications
- ⑩ Serial number

---

## Accessories and Options

### Introduction

The ATV320 drives are designed to take numerous accessories and options to increase their functionality. For a detailed description and catalog numbers, refer to the Catalog on [schneider-electric.com](http://schneider-electric.com)

All accessories and options come with an Instruction Sheet to help installation and commissioning. Therefore you will only find here a short product description.

### Accessories and Options

#### Control Block 90° Bracket

This optional bracket allows the drive to be mounted in a shallow enclosure. For further information about this option, please refer to [www.schneider-electric.com](http://www.schneider-electric.com). This mounting type only applies to frame sizes 1B and 2B. The option is delivered with detailed mounting Instruction Sheet.

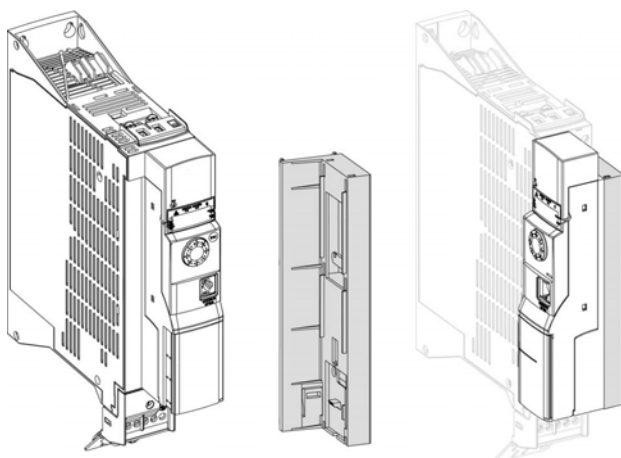

#### GV2 Circuit Breaker

The ATV320, frame sizes 1B and 2B are prepared to be equipped with an optional GV2 circuit-breaker. For further information about the optional GV2 circuit-breaker, bracket and adapter plate, please refer to [www.schneider-electric.com](http://www.schneider-electric.com). The options are supplied with detailed mounting Instruction Sheet.

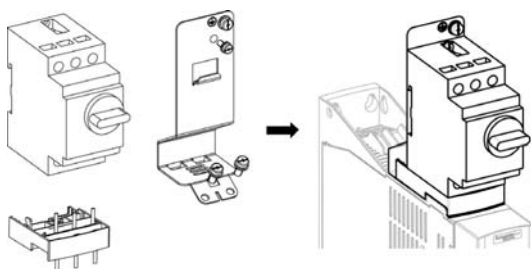

**NOTE:** The product overall dimension, including GV2 adapter and EMC plate mounted, becomes 424 mm (16.7 in.)

#### Display Terminal

- Remote graphic display terminal
- Door mounting kit
- Remote LED display terminal

#### Drive Mounting and Wiring

- EMC plate
- Kit for conformity to UL Type 1
- DIN rail kit

#### Spare Parts

- Fan replacement kit
- Removable control terminal block



---

**Connection and Communication**

- 2 x RJ45 daisy chain CANopen
- Bluetooth adapter
- Option module adapter
- Fieldbus module: DeviceNet, Modbus TCP/ EtherNet/IP, PROFIBUS DP, EtherCAT, PROFINET, Powerlink



---

## Chapter 2

### Technical Data

---

#### What Is in This Chapter?

This chapter contains the following topics:

Topic	Page
Environmental Conditions	20
Dimensions and Weights	21
Drive Ratings	30

## Environmental Conditions

### Withstand to harsh environments

- Chemical class 3C3 conforming to IEC/EN 60721
- Mechanical class 3S2 conforming to IEC/EN 60721

### Temperature Conditions

Ambient Air Temperature

For	Temperature		Comments
Storage	°C	-25...70	-
	°F	-13...158	
Operation	°C	-10...50	Without derating
	°F	14...122	
	°C	50...60	With derating
	°F	122...158	

### Relative Humidity

Without dripping water and without condensation: 5...95%

### Operating Altitude

Operating altitude according to drive type

Drive	Operating altitude		Derating
All drives	m	Up to 1000	Without
	ft	Up to 3280	
ATV320...M2B, ATV320...M2C ATV320...M3C	m	1000...2000	1% (maxi) per additional 100 m (328 ft) and for corner grounded supply mains only
	ft	3280...6560	
ATV320...S6C	m	1000...2000	1% (maxi) per additional 100 m (328 ft) (1)
	ft	3280...6560	
ATV320...N4B, ATV320...N4C	m	1000...3000	1% (maxi) per additional 100 m (328 ft)
	ft	3280...9840	
<b>(1) ATV320...S6C drives cannot be operated on corner grounded systems.</b>			

### Pollution Degree and Degree of Protection

Operating altitude according to drive type

Drive	Pollution Degree	Degree of Protection
ATV320...B	2	IP20
ATV320...C	2	

## Dimensions and Weights

### About the drawings

All drawings CAD files can be downloaded from [www.schneider-electric.com](http://www.schneider-electric.com)

**NOTE:** When designing your installation, please take into account that all depth values should be increased by 40 mm (1.58 in) in case of using the additional slot option. This option module takes place between the graphic display terminal and the drive, causing the depth value to be increased. It enables to connect an option module.

### Frame Size 1B

ATV320U02M2B...ATV320U07M2B, ATV320U04N4B...ATV320U15N4B

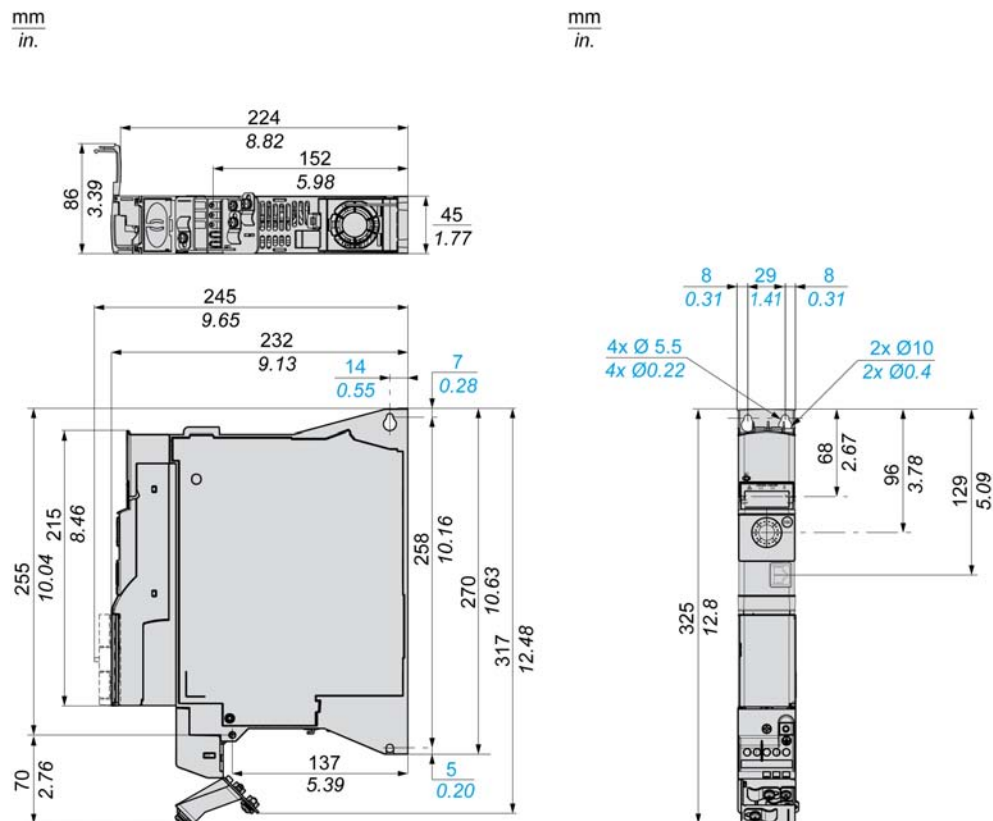

### Weights

Catalog Number	Weight in kg (lb)
ATV320U02M2B	1.59 (3.5)
ATV320U04M2B...07M2B	1.65 (3.64)
ATV320U04N4B	1.62 (3.57)
ATV320U06N4B, U07N4B	1.72 (3.8)
ATV320U11N4B, U15N4B	1.70 (3.75)

## Frame Size 1C

### ATV320U02M•C

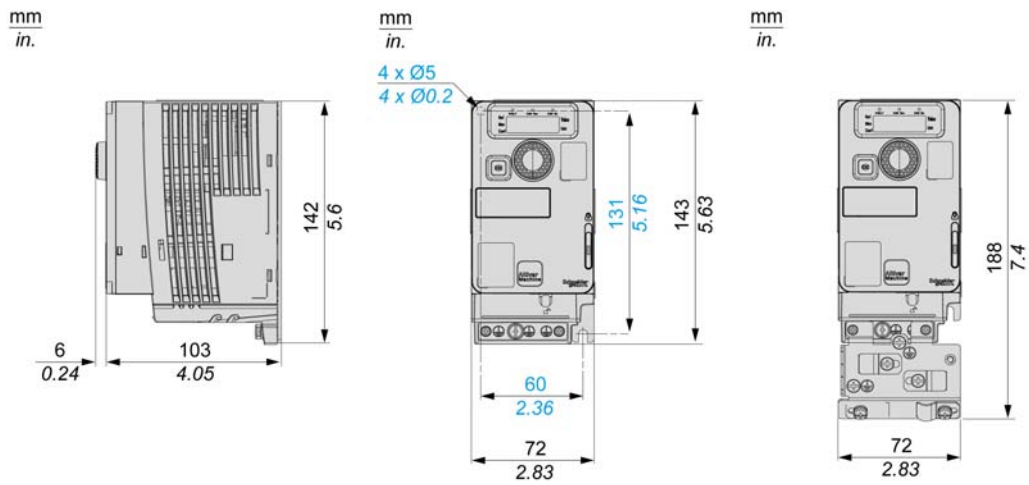

### ATV320U04M•C

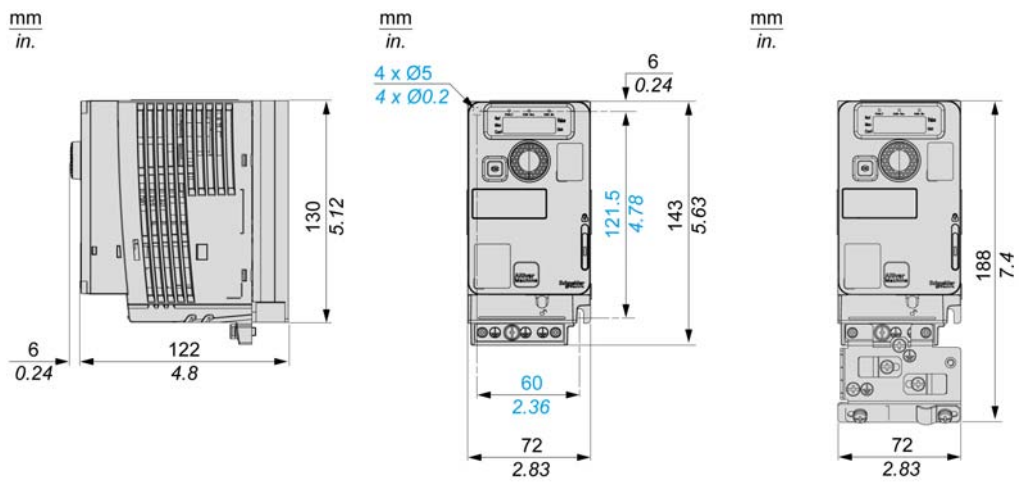

### ATV320U06M2C, ATV320U07M2C

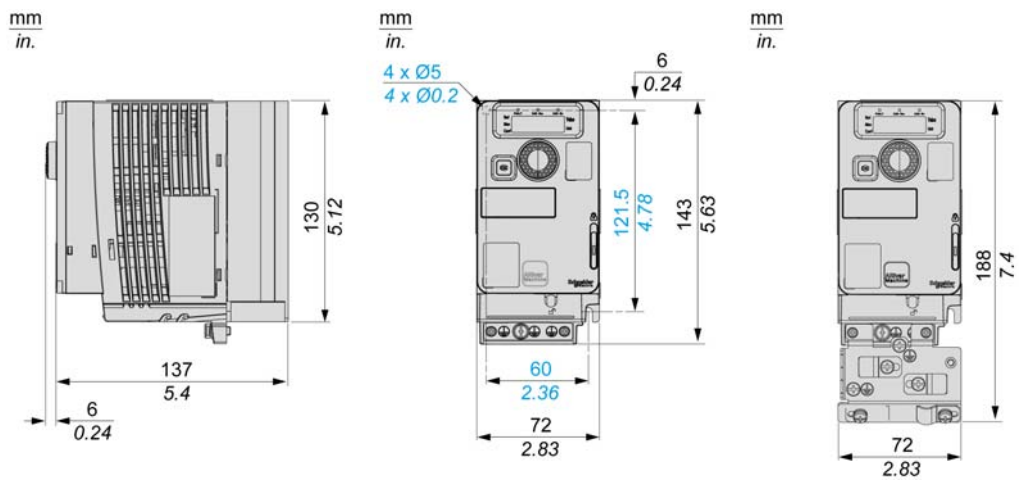

ATV320U06M3C, ATV320U07M3C

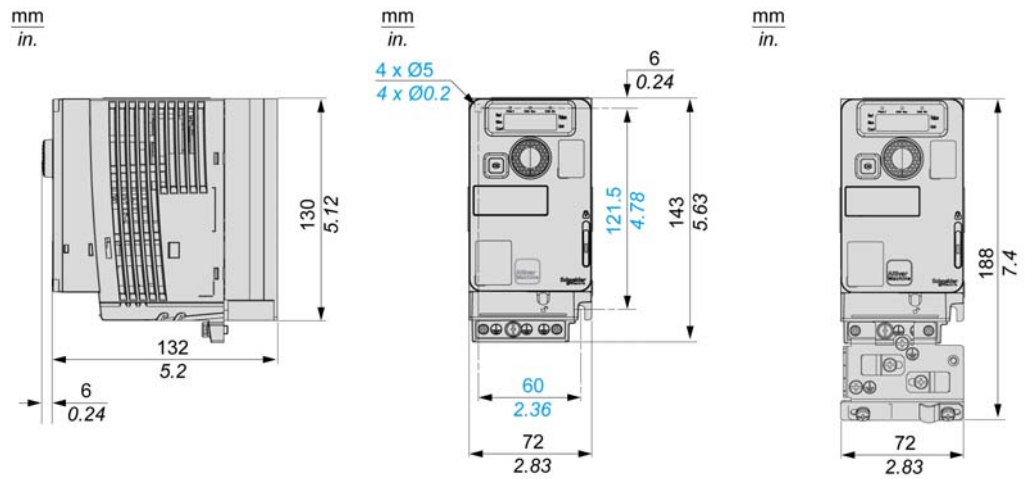

Weights

Catalog Number	Weight in kg (lb)
ATV320U02M-C	0.80 (1.76)
ATV320U04M3C	0.90 (1.98)
ATV320U04M2C, U06M3C, U07M3C	1.0 (2.2)
ATV320U06M2C, U07M2C	1.10 (2.42)

Frame Size 2B

ATV320U11M2B...ATV320U22M2B, ATV320U22N4B...ATV320U40N4B

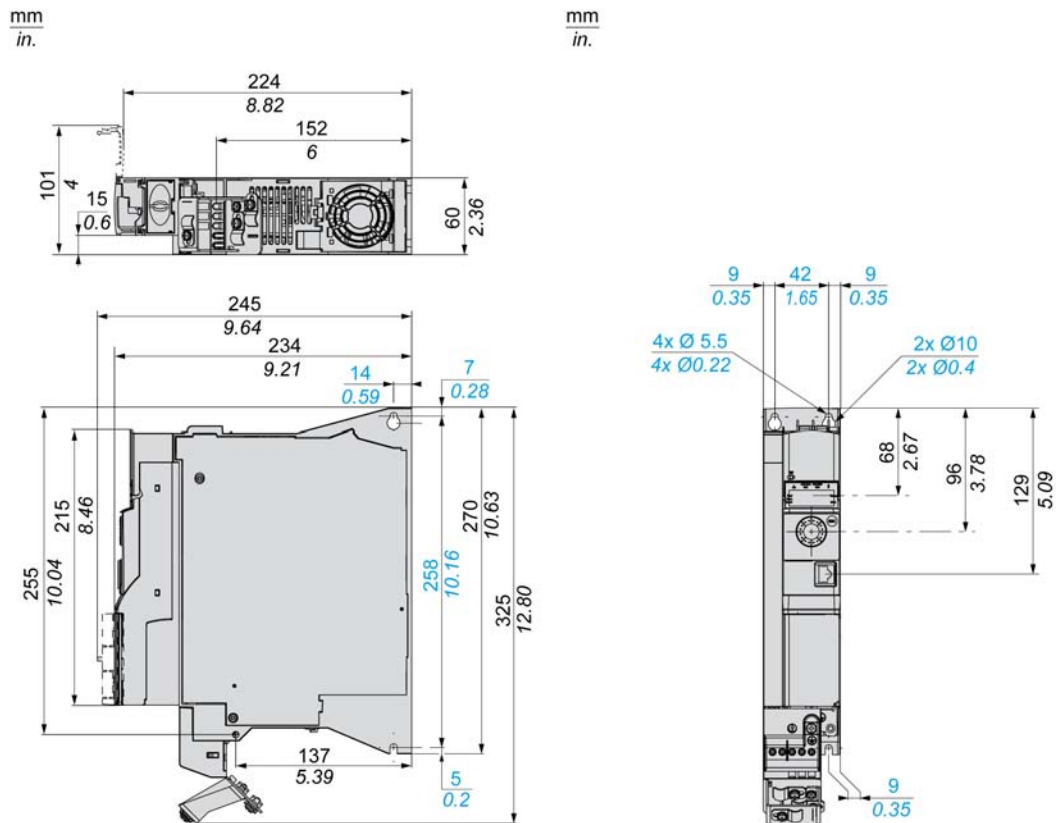

## Weights

Catalog Number	Weight in kg (lb)
ATV320U11M2B, U15M2B	1.95 (4.30)
ATV320U22M2B	2.07 (4.56)
ATV320U22N4B	2.32 (5.11)
ATV320U30N4B	2.12 (4.67)
ATV320U40N4B	2.17 (4.78)

## Frame Size 2C

ATV320U11M2C...ATV320U22M2C, ATV320U04N4C...ATV320U15N4C, ATV320U07S6C, ATV320U15S6C

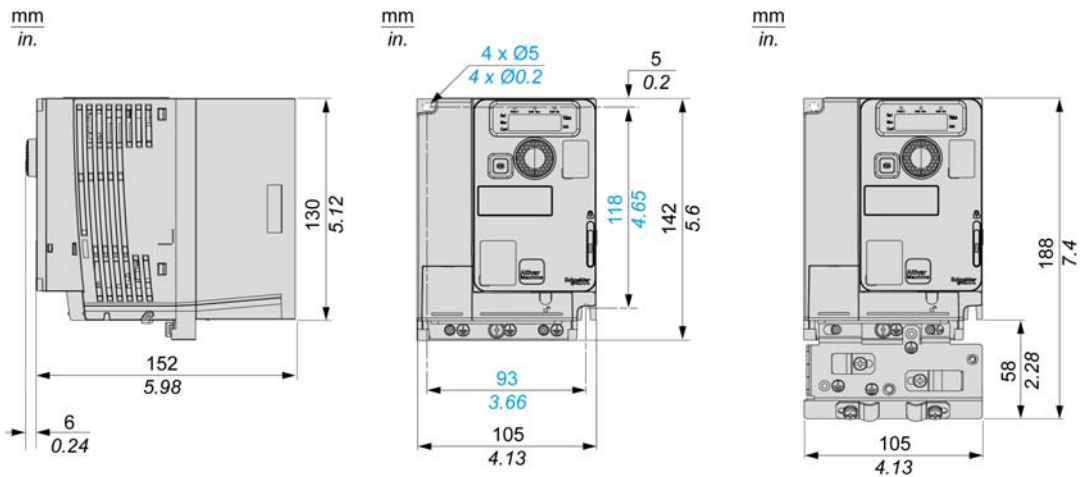

ATV320U11M3C...ATV320U22M3C

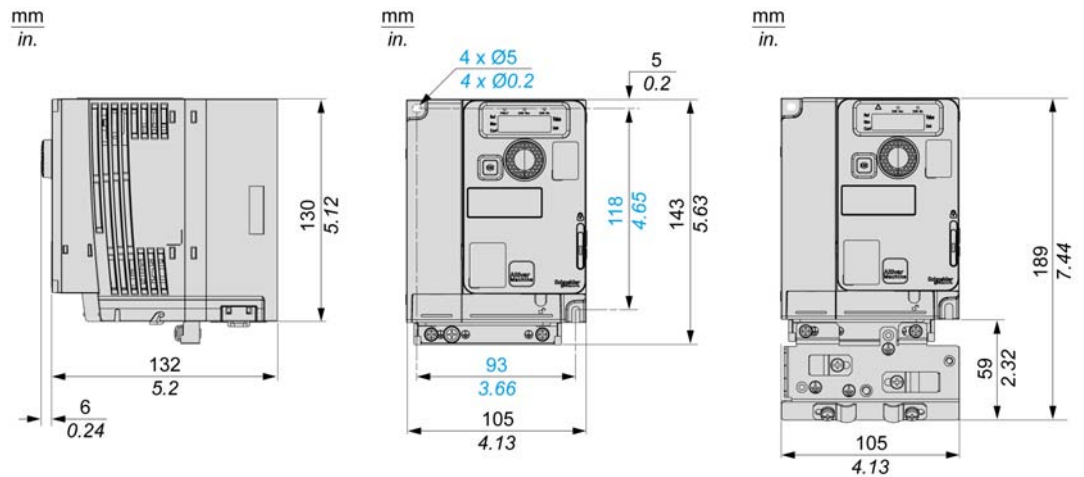

## Weights

Catalog Number	Weight in kg (lb)
ATV320U04N4C...U07N4C	1.20 (2.65)
ATV320U11N4C, U15N4C, U07S6C, U15S6C	1.30 (2.87)
ATV320U11M3C...U22M3C	1.40 (3.08)
ATV320U11M2C...U22M2C	1.60 (3.53)



### Frame Size 3C

ATV320U30M3C and U40M3C, ATV320U22N4C...U40N4C, ATV320U22S6C and ATV320U40S6C

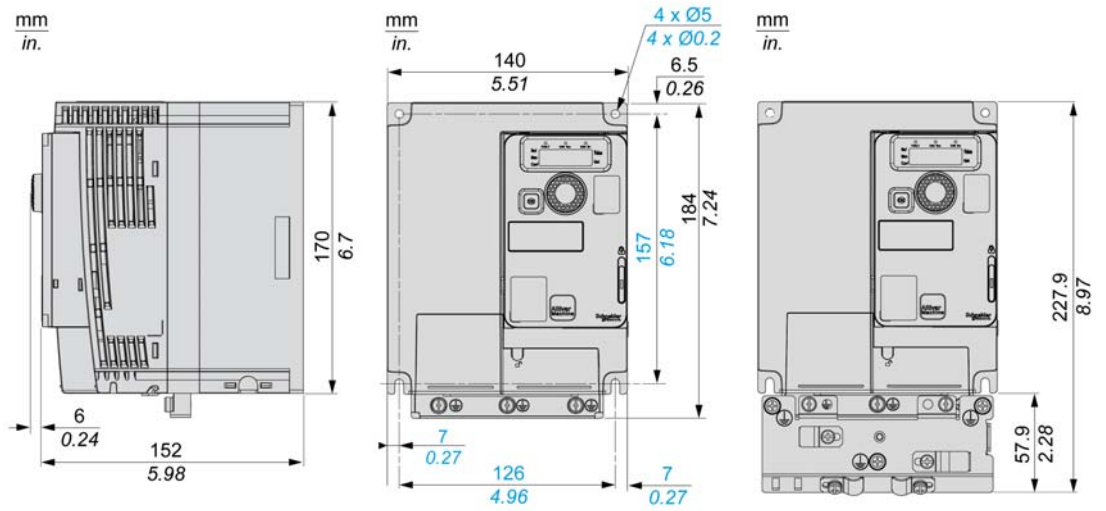

### Weights

Catalog Number	Weight in kg (lb)
ATV320U22S6C, U40S6C	2.00 (4.41)
ATV320U22N4C...U30N4C	2.10 (4.63)
ATV320U30M3C, U40M3C, ATV320U40N4C	2.20 (4.85)

### Frame Size 4B

ATV320U55N4B and ATV320U75N4B

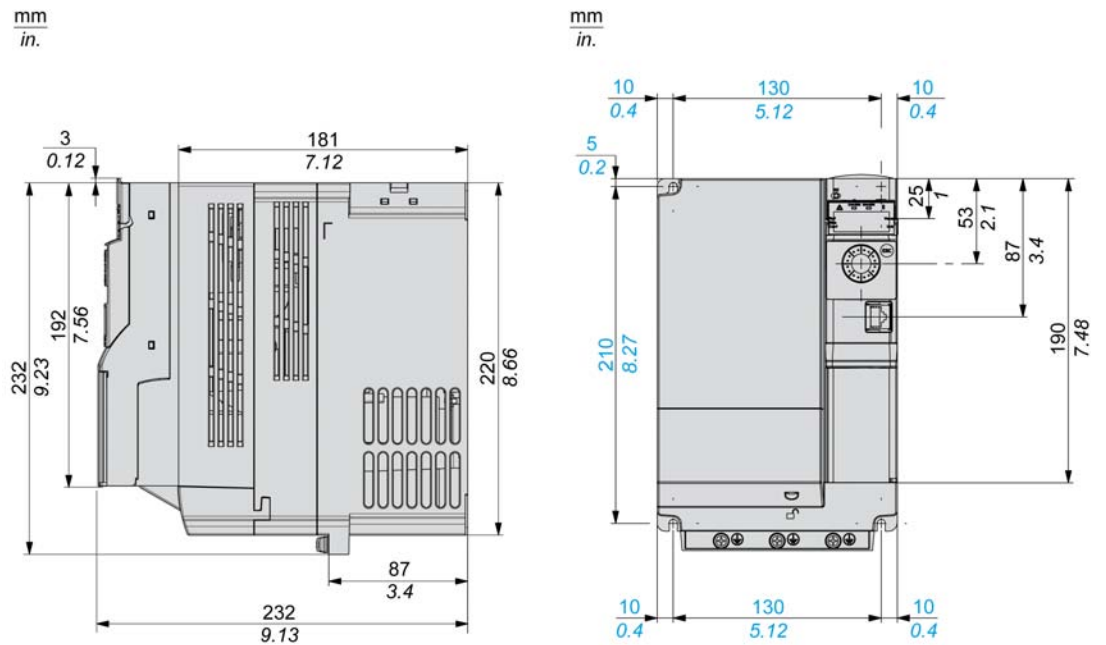

mm  
in.

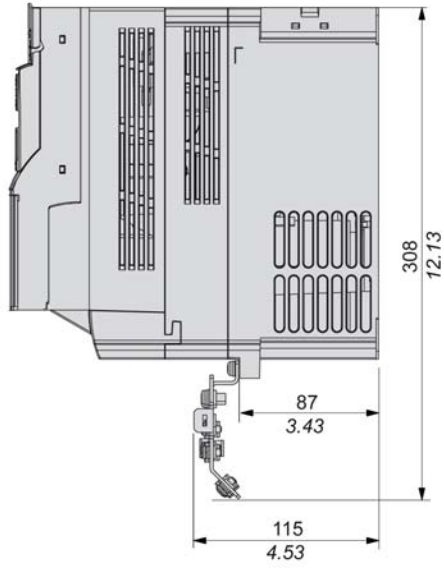

mm  
in.

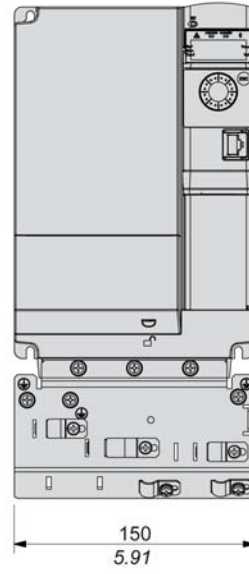

### Weights

Catalog Number	Weight in kg (lb)
ATV320U55N4B, ATV320U75N4B	4.41 (9.72)

### Frame Size 4C

ATV320U55M3C, ATV320U75M3C, ATV320U55S6C, ATV320U75S6C

mm  
in.

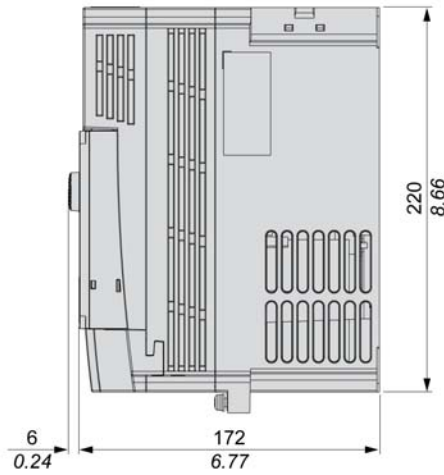

mm  
in.

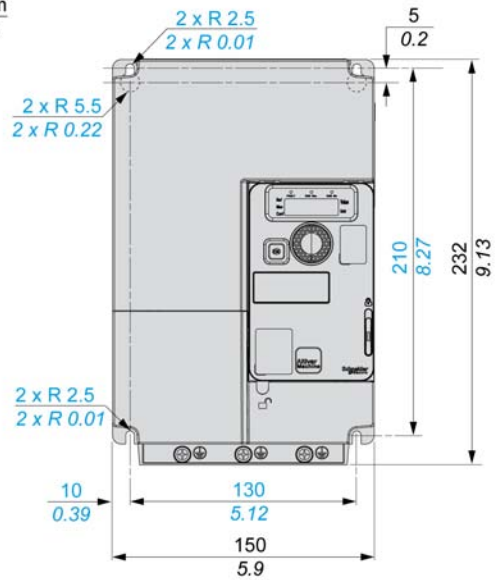

mm  
in.

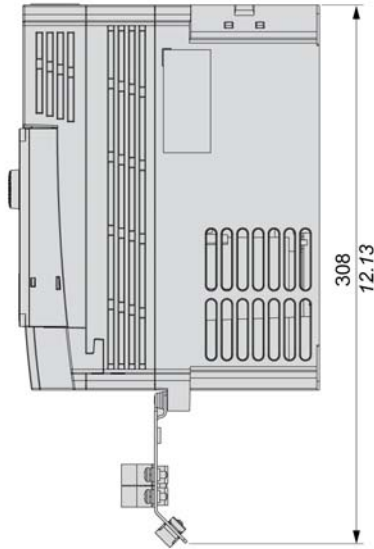

mm  
in.

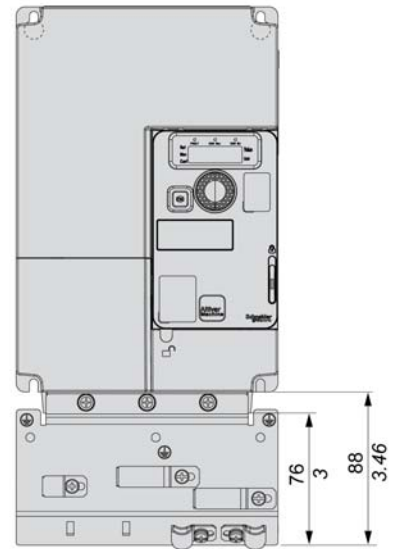

### Weights

Catalog Number	Weight in kg (lb)
ATV320U55M3C, U55S6C	3.5 (7.72)
ATV320U75M3C, U75S6C	3.6 (7.94)

### Frame Size 5B

#### ATV320D11N4B and ATV320D15N4B

mm  
in.

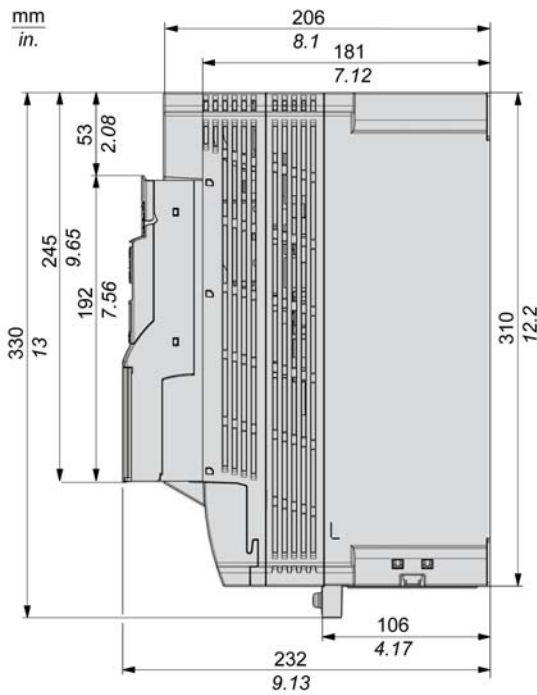

mm  
in.

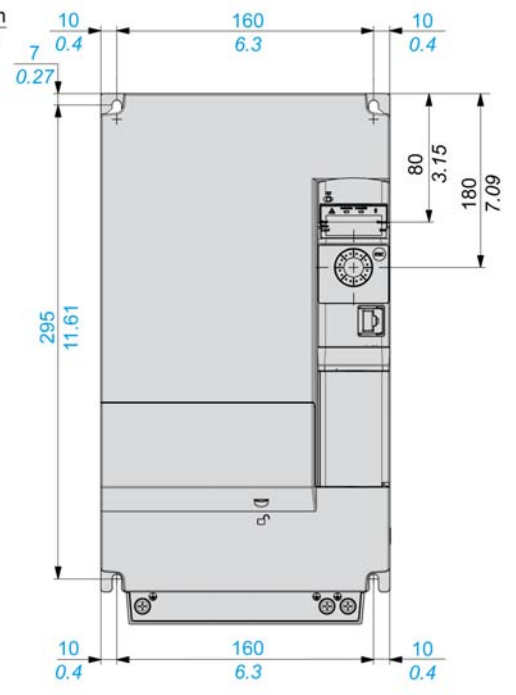

mm  
in.

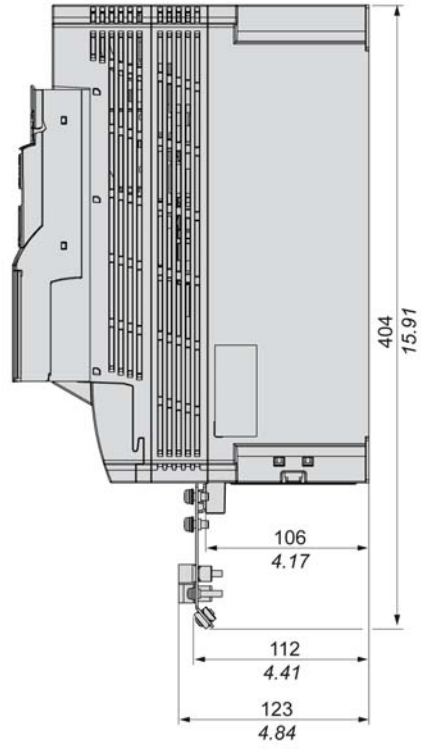

mm  
in.

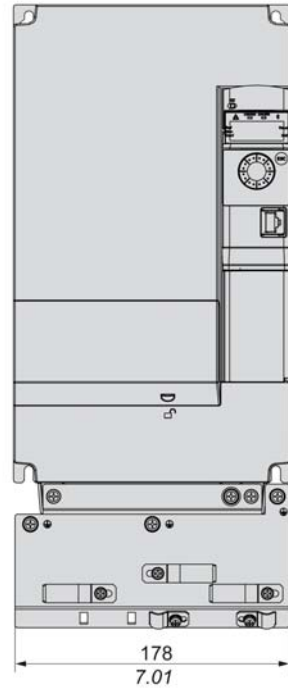

### Weights

Catalog Number	Weight in kg (lb)
ATV320D11N4B, ATV320D15N4B	6.75 (14.88)

Frame Size 5C

ATV320D11M3C, ATV320D15M3C, ATV320D11S6C, ATV320D15S6C

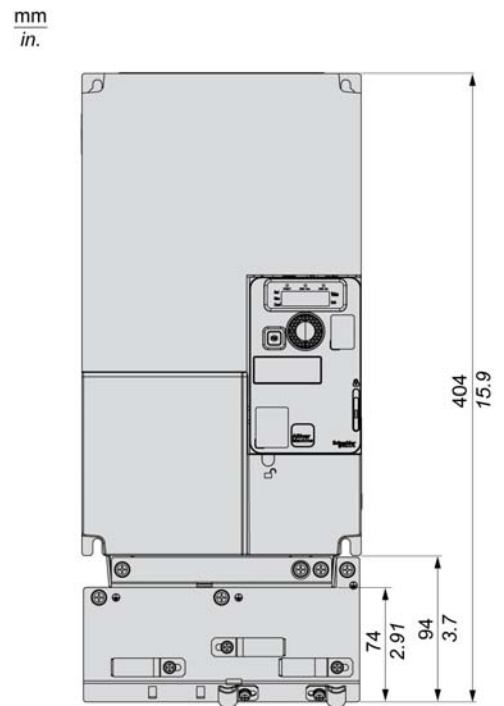
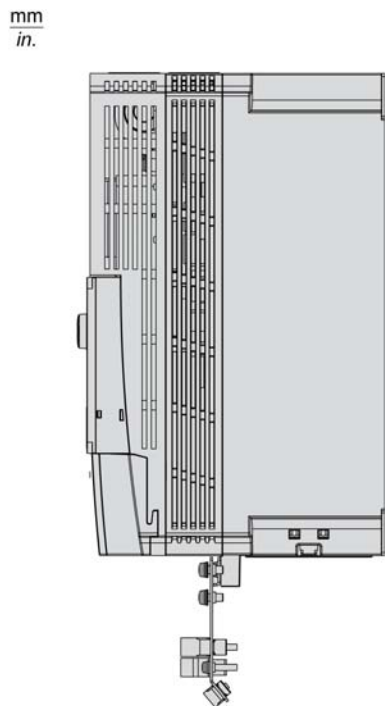
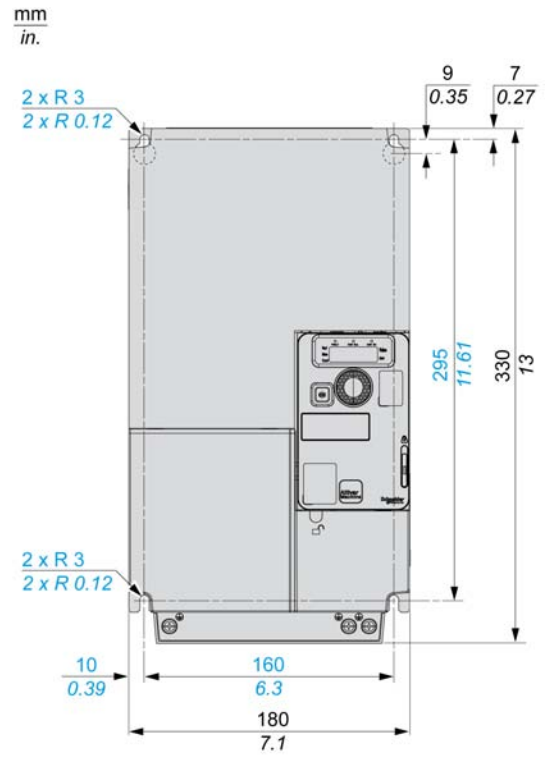
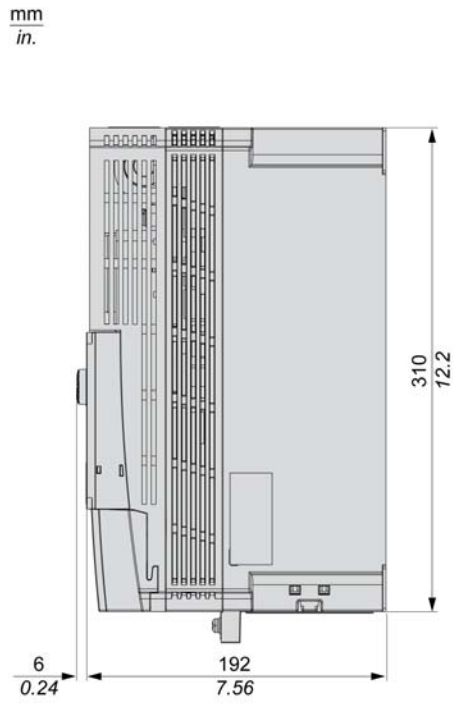

Weights

Catalog Number	Weight in kg (lb)
ATV320D11M3C, D11S6C	6.8 (15.0)
ATV320D15M3C, D15S6C	6.9 (15.2)

## Drive Ratings

### Single phase supply voltage: 200...240 V 50/60 Hz

#### Power and Current Ratings

Catalog Number and Frame Size		Nominal Power (1)		Power Part Supply				Drive (output)	
				Max. Input Current		Apparent Power	Max. Inrush Current (2)	Nominal Current (1)	Max. Transient current(1) (3)
				At 200 Vac	At 240 Vac				
kW	HP	A	A	kVA	A	A	A	A	
ATV320U02M2B	1B	0.18	0.25	3.4	2.8	0.7	9.6	1.5	2.3
ATV320U04M2B	1B	0.37	0.5	6.0	5.0	1.2	9.6	3.3	5.0
ATV320U06M2B	1B	0.55	0.75	7.9	6.7	1.6	9.6	3.7	5.6
ATV320U07M2B	1B	0.75	1.0	10.1	8.5	2.0	9.6	4.8	7.2
ATV320U11M2B	2B	1.1	1.5	13.6	11.5	2.8	19.1	6.9	10.4
ATV320U15M2B	2B	1.5	2.0	17.6	14.8	3.6	19.1	8.0	12.0
ATV320U22M2B	2B	2.2	3.0	23.9	20.1	4.8	19.1	11.0	16.5
ATV320U02M2C	1C	0.18	0.25	3.4	2.8	0.7	9.6	1.5	2.3
ATV320U04M2C	1C	0.37	0.5	5.9	4.9	1.2	9.6	3.3	5.0
ATV320U06M2C	1C	0.55	0.75	7.9	6.6	1.6	9.6	3.7	5.6
ATV320U07M2C	1C	0.75	1.0	10.0	8.4	2.0	9.6	4.8	7.2
ATV320U11M2C	2C	1.1	1.5	13.8	11.6	2.8	19.1	6.9	10.4
ATV320U15M2C	2C	1.5	2.0	17.8	14.9	3.6	19.1	8.0	12.0
ATV320U22M2C	2C	2.2	3.0	24.0	20.2	4.8	19.1	11.0	16.5

(1) The switching frequency is adjustable from 2...16 kHz, rated value: 4 kHz.  
For operation at switching frequencies higher than the rated value. Derating must be applied to the drive (output current (see page 40)). In this case, switching frequency can be reduced if an excessive temperature rise occurs.

(2) Peak current when power is switched On, for the maximum supply mains voltage.

(3) The drive is designed to run up to 60 s at 150% of nominal current.

### 3-phase supply voltage: 200...240 V 50/60 Hz

#### Power and Current Ratings

Catalog Number and Frame Size		Nominal Power (1)		Power Part Supply				Drive (output)	
				Max. Input Current		Apparent Power	Max. Inrush Current (2)	Nominal Current (1)	Max. Transient current(1) (3)
				At 200 Vac	At 240 Vac				
kW	HP	A	A	kVA	A	A	A	A	
ATV320U02M3C	1C	0.18	0.25	2.0	1.7	0.7	9.6	1.5	2.3
ATV320U04M3C	1C	0.37	0.5	3.6	3.0	1.2	9.6	3.3	5.0
ATV320U06M3C	1C	0.55	0.75	4.9	4.2	1.7	9.6	3.7	5.6
ATV320U07M3C	1C	0.75	1.0	6.3	5.3	2.2	9.6	4.8	7.2
ATV320U11M3C	2C	1.1	1.5	8.6	7.2	3.0	9.6	6.9	10.4
ATV320U15M3C	2C	1.5	2.0	11.1	9.3	3.9	9.6	8.0	12.0
ATV320U22M3C	2C	2.2	3.0	14.9	12.5	5.2	9.6	11.0	16.5
ATV320U30M3C	3C	3.0	–	19.0	15.9	6.6	28.7	13.7	20.6
ATV320U40M3C	3C	4.0	5.0	23.8	19.9	8.3	28.7	17.5	23.6
ATV320U55M3C	4C	5.5	7.5	35.4	29.8	12.4	35.2	27.5	41.3
ATV320U75M3C	4C	7.5	10.0	45.3	38.2	15.9	35.2	33.0	49.5
ATV320D11M3C	5C	11.0	15.0	60.9	51.4	21.4	66.7	54.0	81.0
ATV320D15M3C	5C	15.0	20.0	79.7	67.1	27.9	66.7	66.0	99.0

(1) The switching frequency is adjustable from 2...16 kHz, rated value: 4 kHz.  
For operation at switching frequencies higher than the rated value. Derating must be applied to the drive (output current (see page 40)). In this case, switching frequency can be reduced if an excessive temperature rise occurs.

(2) Peak current when power is switched On, for the maximum supply mains voltage.

(3) The drive is designed to run up to 60 s at 150% of nominal current.

### 3-phase supply voltage: 380...500 Vac 50/60 Hz

#### Power and Current Ratings

Catalog Number and Frame Size		Nominal Power (1)		Power Part Supply				Drive (output)	
				Max. Input Current		Apparent Power	Max. Inrush Current (2)	Nominal Current (1)	Max. Transient current (1) (3)
				At 380 Vac	At 500 Vac				
kW	HP	A	A	kVA	A	A	A		
ATV320U04N4B	1B	0.37	0.5	2.1	1.6	1.4	10.0	1.5	2.3
ATV320U06N4B	1B	0.55	0.75	2.8	2.2	1.9	10.0	1.9	2.9
ATV320U07N4B	1B	0.75	1.0	3.6	2.7	2.3	10.0	2.3	3.5
ATV320U11N4B	1B	1.1	1.5	5.0	3.8	3.3	10.0	3.0	4.5
ATV320U15N4B	1B	1.5	2.0	6.5	4.9	4.2	10.0	4.1	6.2
ATV320U22N4B	2B	2.2	3.0	8.7	6.6	5.7	10.0	5.5	8.3
ATV320U30N4B	2B	3.0	–	11.1	8.4	7.3	10.0	7.1	10.7
ATV320U40N4B	2B	4.0	5.0	13.7	10.5	9.1	10.0	9.5	14.3
ATV320U55N4B	4B	5.5	7.5	20.7	14.5	12.6	27.6	14.3	21.5
ATV320U75N4B	4B	7.5	10.0	26.5	18.7	16.2	27.6	17.0	25.5
ATV320D11N4B	5B	11.0	15.0	36.6	25.6	22.2	36.7	27.7	41.6
ATV320D15N4B	5B	15.0	20.0	47.3	33.3	28.8	36.7	33.0	49.5
ATV320U04N4C	2C	0.37	0.5	2.1	1.6	1.4	10.0	1.5	2.3
ATV320U06N4C	2C	0.55	0.75	2.8	2.2	1.9	10.0	1.9	2.9
ATV320U07N4C	2C	0.75	1.0	3.6	2.8	2.4	10.0	2.3	3.5
ATV320U11N4C	2C	1.1	1.5	5.0	3.8	3.3	10.0	3.0	4.5
ATV320U15N4C	2C	1.5	2.0	6.4	4.9	4.2	10.0	4.1	6.2
ATV320U22N4C	3C	2.2	3.0	8.7	6.6	5.7	10.0	5.5	8.3
ATV320U30N4C	3C	3.0	–	11.1	8.4	7.3	10.0	7.1	10.7
ATV320U40N4C	3C	4.0	5.0	13.7	10.6	9.2	10.0	9.5	14.3

- (1) The switching frequency is adjustable from 2...16 kHz, rated value: 4 kHz:  
For operation at switching frequencies higher than the rated value. Derating must be applied to the drive (output) current (see page 40). In this case, switching frequency can be reduced if an excessive temperature rise occurs.
- (2) Peak current when power is switched On, for the maximum supply mains voltage.
- (3) The drive is designed to run up to 60 s at 150% of nominal current.

### 3-phase supply voltage: 525...600 Vac 50/60 Hz

#### Power and Current Ratings

Catalog Number and Frame Size		Nominal Power (1)		Power Part Supply				Drive (output)	
				Max. Input Current		Apparent Power	Max. Inrush Current (2)	Nominal Current (1)	Max. Transient current (1) (3)
				At 525 Vac	At 600 Vac				
kW	HP	A	A	kVA	A	A	A		
ATV320U07S6C	2C	0.75	1.0	1.5	1.4	1.5	12.0	1.7	2.6
ATV320U15S6C	2C	1.5	2.0	2.6	2.4	2.5	12.0	2.7	4.1
ATV320U22S6C	3C	2.2	3.0	3.7	3.2	3.4	12.0	3.9	5.9
ATV320U40S6C	3C	4.0	5.0	6.5	5.8	6.0	12.0	6.1	9.2
ATV320U55S6C	4C	5.5	7.5	8.4	7.5	7.8	33.1	9.0	13.5
ATV320U75S6C	4C	7.5	10.0	11.6	10.5	10.9	33.1	11.0	16.5
ATV320D11S6C	5C	11.0	15.0	15.8	14.1	14.7	44.0	17.0	25.5
ATV320D15S6C	5C	15.0	20.0	22.1	20.1	20.9	44.0	22.0	33.0

- (1) The switching frequency is adjustable from 2...16 kHz, rated value: 4 kHz:  
For operation at switching frequencies higher than the rated value. Derating must be applied to the drive (output) current (see page 40). In this case, switching frequency can be reduced if an excessive temperature rise occurs.
- (2) Peak current when power is switched On, for the maximum supply mains voltage.
- (3) The drive is designed to run up to 60 s at 150% of nominal current.





---

# Chapter 3

## Drive Mounting

---

### What Is in This Chapter?

This chapter contains the following topics:

Topic	Page
Green Premium™	34
Steps for setting up the drive	35
Initial Steps	36
Mounting Conditions	37
Derating Curves	40
Mounting	47

---

## Green Premium™

### Description

Information on the environmental impact of products, their resource efficiency, and end-of-life instructions.

### Easy access to information: "Check Your Product"

Certificates and relevant product information available at the address:

[www.schneider-electric.com/green-premium](http://www.schneider-electric.com/green-premium)

You can download RoHS and REACH compliance declarations, Product Environmental Profiles (PEP) and End-of-Life instructions (EoLi).



## Steps for setting up the drive

### Procedure

## **INSTALLATION**

### ① Receive and inspect the drive controller

- Check that the catalog number printed on the label is the same as that on the purchase order
- Remove the drive from its packaging and check that it has not been damaged

### ② Verify the supply mains

- Verify that the supply mains is compatible with the power part supply range of the drive.

### ③ Mount the drive

- Mount the drive in accordance with the instructions in this document
- Install the transformer(s), if any
- Install any internal and external options

### ④ Wire the drive

- Connect the motor, ensuring that its connections correspond to the voltage
- Connect the supply mains, after making sure that the power is off
- Connect the control

*Steps 1 to 4 must be performed with the power off.*



## ⑤ **PROGRAMMING**

Refer to the Programming Manual

---

## Initial Steps

### Handling and Storage

#### **WARNING**

##### **DANGEROUS HANDLING**

- Do not handle a damaged packaging.
- Open and handle the packaging with care.

**Failure to follow these instructions can result in death, serious injury, or equipment damage.**

To help protect the drive before installation, handle and store the device in its packaging. Ensure that the ambient conditions are acceptable.

### Check the Delivery of the Drive

Damaged products or accessories may cause electric shock or unanticipated equipment operation.

#### **DANGER**

##### **ELECTRIC SHOCK OR UNANTICIPATED EQUIPMENT OPERATION**

Do not use damaged products or accessories.

**Failure to follow these instructions will result in death or serious injury.**

Contact your local Schneider Electric sales office if you detect any damage whatsoever.

Step	Action
1	Remove the drive from the packaging and verify that it has not been damaged
2	Verify that the catalog number printed on the nameplate corresponds to the purchase order.

## Mounting Conditions

### Before You Begin

Conductive foreign objects, dust or liquids or damaged parts may cause parasitic voltage.

 <b>DANGER</b>
<b>ELECTRIC SHOCK CAUSED BY FOREIGN OBJECTS OR DAMAGE</b> <ul style="list-style-type: none"><li>• Do not use damaged products.</li><li>• Keep foreign objects such as chips, screws or wire clippings from getting into the product.</li><li>• Verify correct seat of seals and cable entries in order to avoid deposits and humidity.</li></ul> <b>Failure to follow these instructions will result in death or serious injury.</b>

The temperature of the products described in this manual may exceed 80 °C (176 °F) during operation.

 <b>WARNING</b>
<b>HOT SURFACES</b> <ul style="list-style-type: none"><li>• Ensure that any contact with hot surfaces is avoided.</li><li>• Do not allow flammable or heat-sensitive parts in the immediate vicinity of hot surfaces.</li><li>• Verify that the product has sufficiently cooled down before handling it.</li><li>• Verify that the heat dissipation is sufficient by performing a test run under maximum load conditions.</li></ul> <b>Failure to follow these instructions can result in death, serious injury, or equipment damage.</b>

Power Drive Systems (PDS) can generate strong local electrical and magnetic fields. This can cause interference in electromagnetically sensitive devices.

 <b>WARNING</b>
<b>ELECTROMAGNETIC FIELDS</b> <ul style="list-style-type: none"><li>• Keep persons with electronic medical implants, such as pacemakers, away from the equipment.</li><li>• Do not place electromagnetically sensitive devices in the vicinity of the equipment.</li></ul> <b>Failure to follow these instructions can result in death, serious injury, or equipment damage.</b>

### Attaching A Label With Safety Instructions

A label kit is provided with the drive.

Step	Action
1	Observe the safety regulations in the targeted country
2	Select the label suitable for the targeted country
3	Attach the label to the front of the device so that it is clearly visible. Below is the English version 

**Mounting Types for ATV320...B Drives**

Drive operation is suitable at surrounding air temperature less or equal to 50°C (122°F), for a switching frequency of 4 kHz, for use in continuous operation.

Above this temperature, up to 60°C (140°F), or if operation above 4 kHz needs to be continuous, the nominal drive current should be derated according to the derating curves.

Above 4 kHz, the drive will reduce the switching frequency automatically in the event of an excessive temperature rise.

On optional GV2 circuit-breaker (1) can be mounted on size 1B and 2B

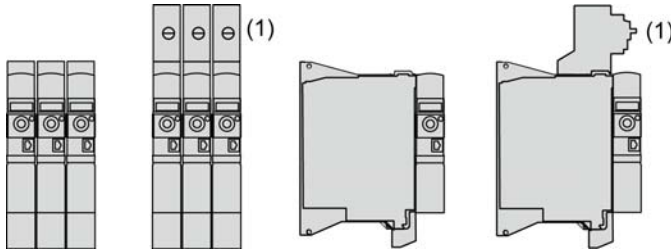

**Mounting Type A for ATV320...C Drives**

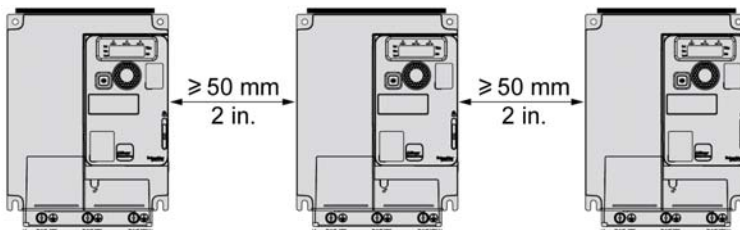

Free space  $\geq 50$  mm (2 in.) on each side, with vent cover fitted. Mounting type A is suitable for drive operation at surrounding air temperature less or equal to 50 °C (122 °F)

**Mounting Type B for ATV320...C Drives**

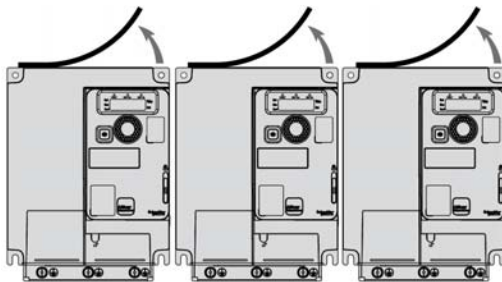

Drives mounted side-by-side, vent cover should be removed. The degree of protection becomes IP20.

**Mounting Type C for ATV320...C Drives**

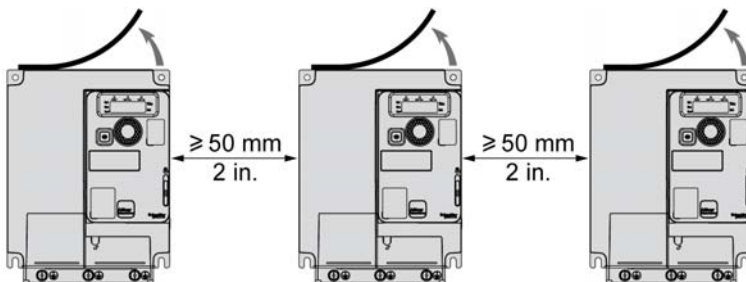

Free space  $\geq 50$  mm (2 in.) on each side. Vent cover should be removed for operation at surrounding air temperature above 50 °C (122 °F). The degree of protection becomes IP20.

## Clearances and Mounting Position

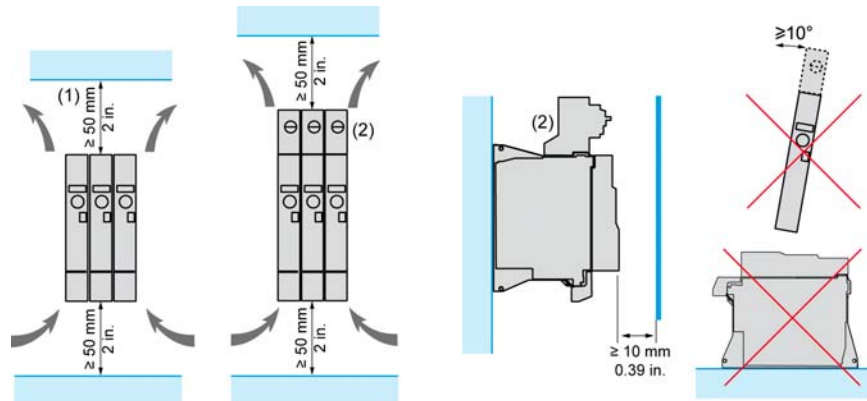

- (1) Minimum value corresponding to thermal constraint. On sizes 1B and 2B, a 150 mm (5.9 in.) clearance may help to connect the ground.  
(2) Optional GV2 circuit-breaker

## General Mounting Instructions

- Mount the device in a vertical position at  $\pm 10^\circ$ . This is required for cooling the device.
- Attach it on the mounting surface in compliance with standards, using screws according to the table given in the Mounting section (*see page 47*).
- The use of washers is required with all mounting screws.
- Tighten the fixation screws.
- Do not mount the device close to heat sources.
- Avoid environmental effects like high temperatures and high humidity as well as dust, dirt and conductive gases.
- Adhere to the minimum installation distances for required cooling.
- Do not mount the device on flammable materials.
- Install the drive on a solid, vibration-free support.
- Frame size 1B and 2B can be installed horizontally without derating, except side by side mounting, and provided that:
  - the upper side is the one with the air inlets,
  - clearances around the drive are the same than for vertical mounting.

## Derating Curves

### Description

Derating curves for the nominal drive current ( $I_n$ ) as a function of temperature and switching frequency.

#### ATV320...M2B

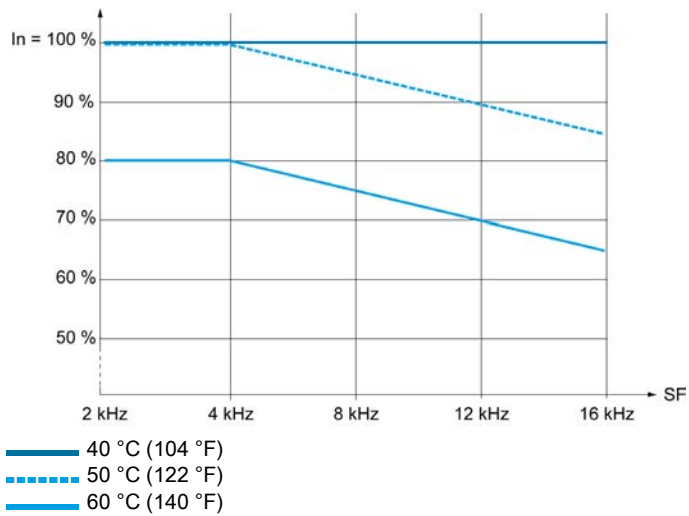

#### ATV320...N4B

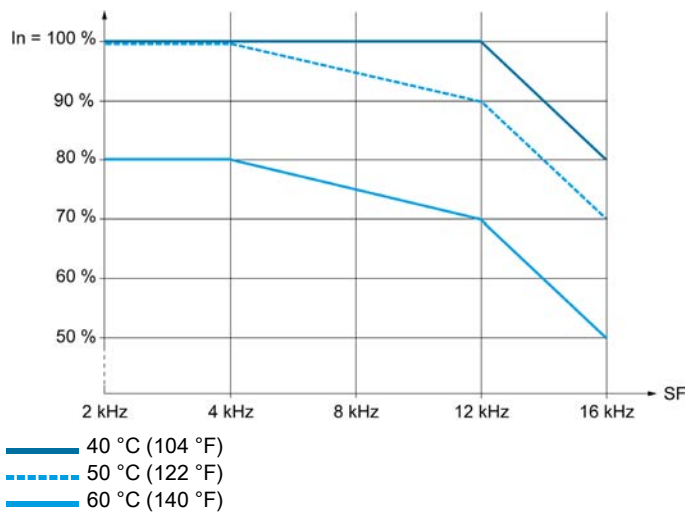

#### ATV320U02M2C...ATV320U7M2C

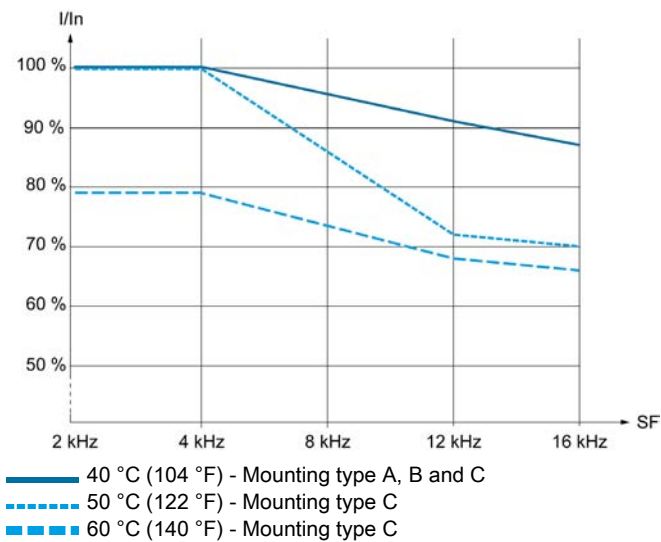



**ATV320U11M2C...ATV320U22M2C**

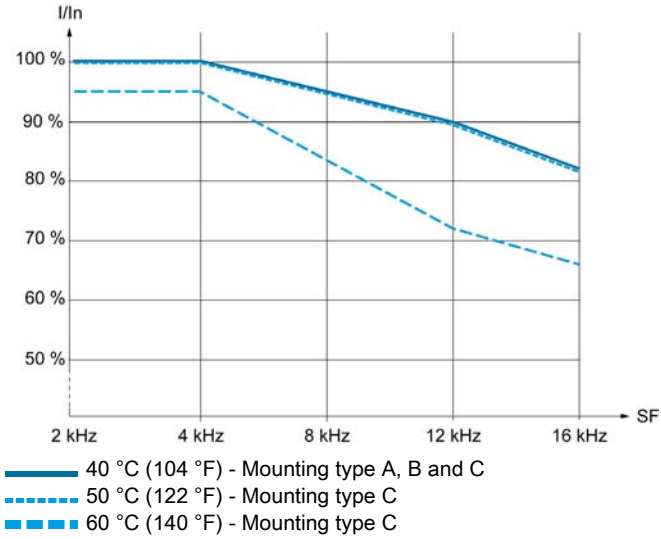

**ATV320U04N4C...ATV320U15N4C**

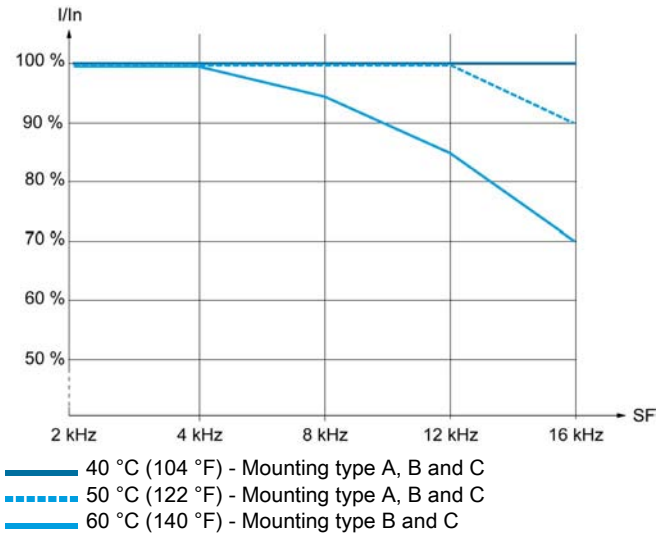

**ATV320U22N4C...ATV320U40N4C**

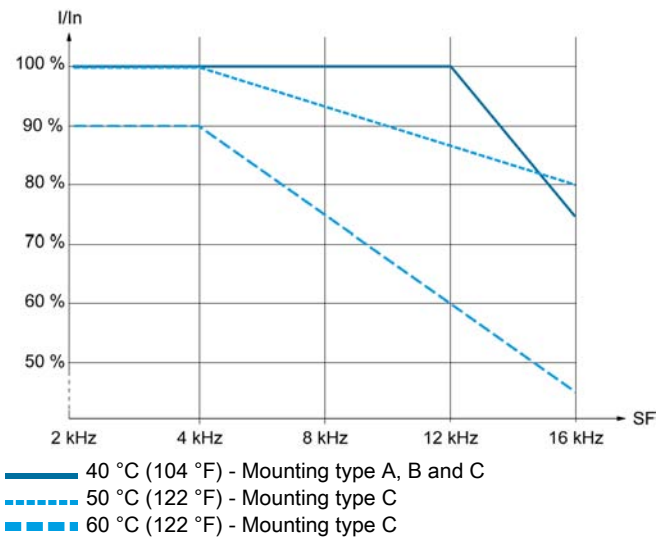

### ATV320U02M3C...ATV320U07M3C

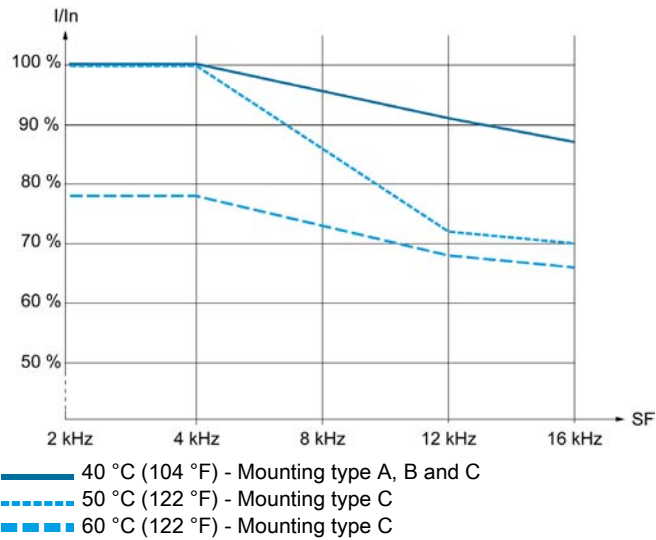

### ATV320U11M3C...ATV320U22M3C

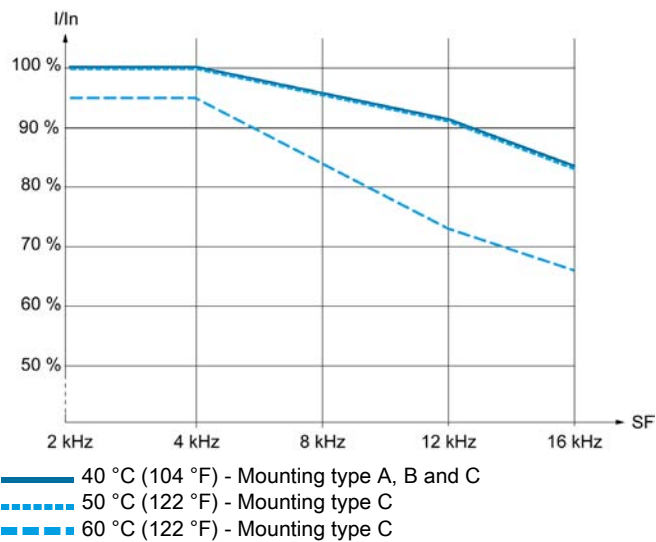

### ATV320U30M3C...ATV320U40M3C

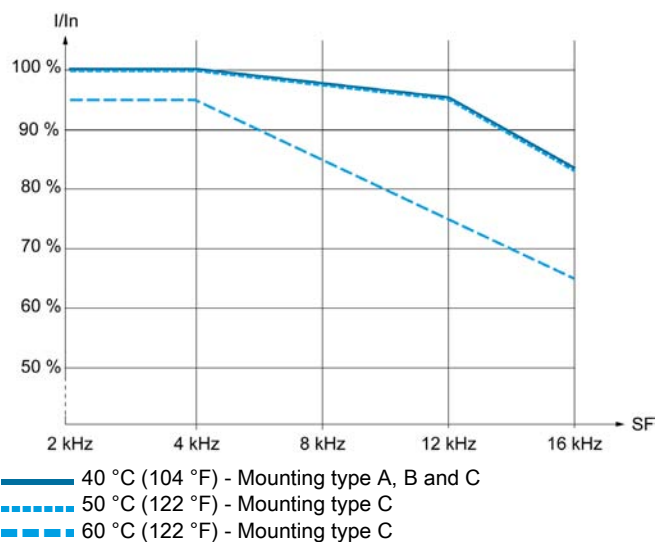

**ATV320U55M3C and ATV320U75M3C**

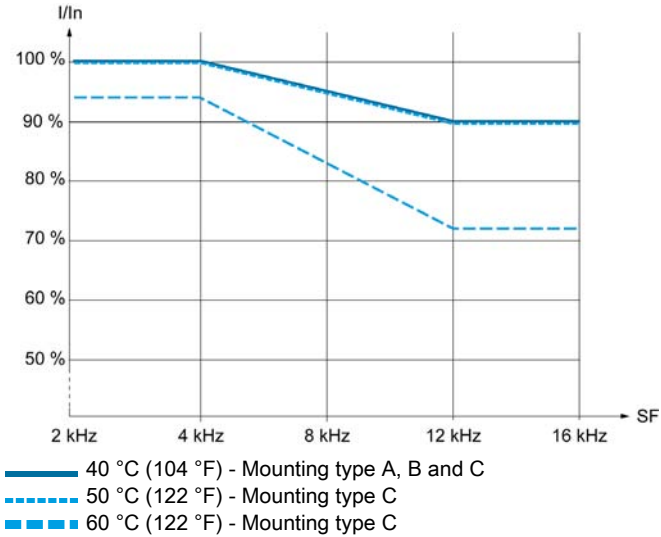

**ATV320D11M3C and ATV320D15M3C**

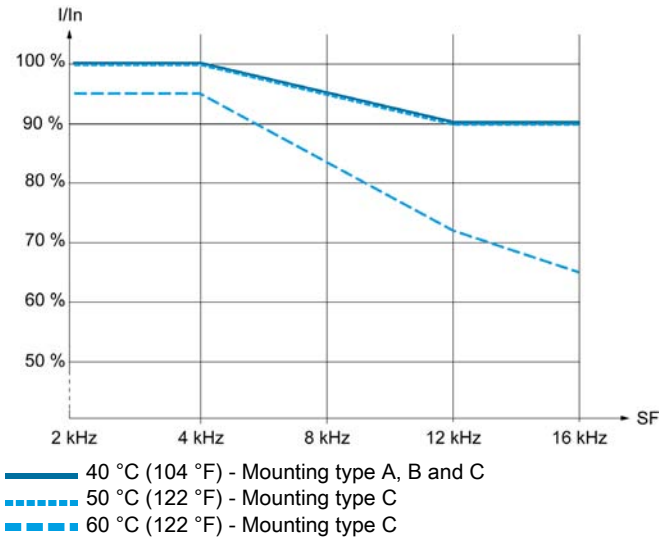

**ATV320U07S6C and ATV320U15S6C**

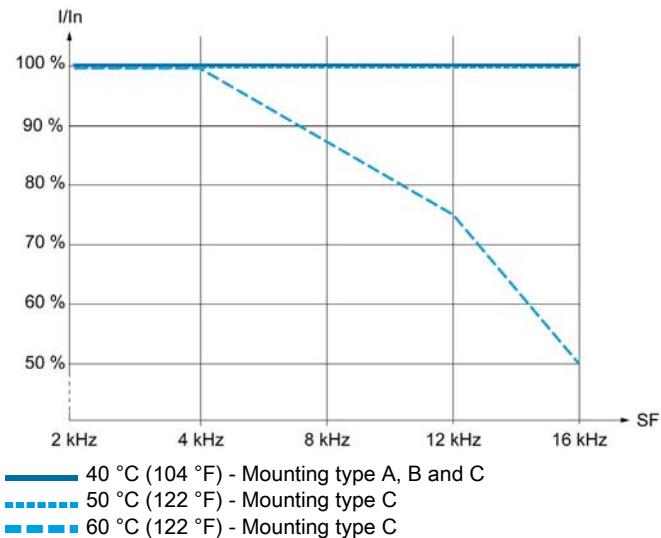

### ATV320U22S6C and ATV320U40S6C

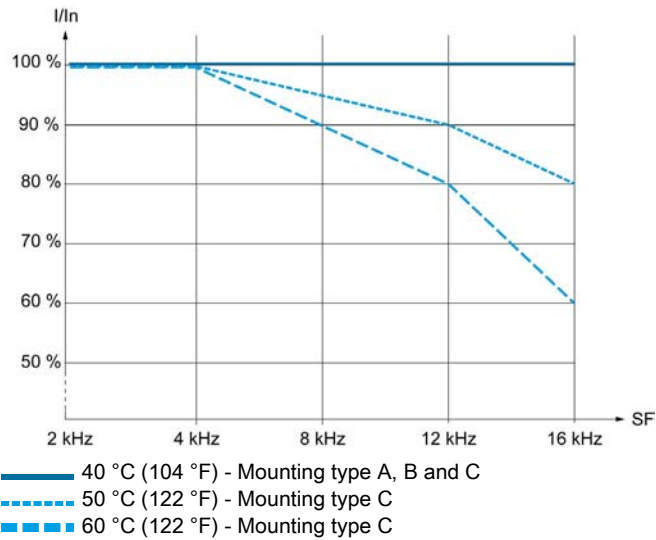

### ATV320U55S6C and ATV320U75S6C

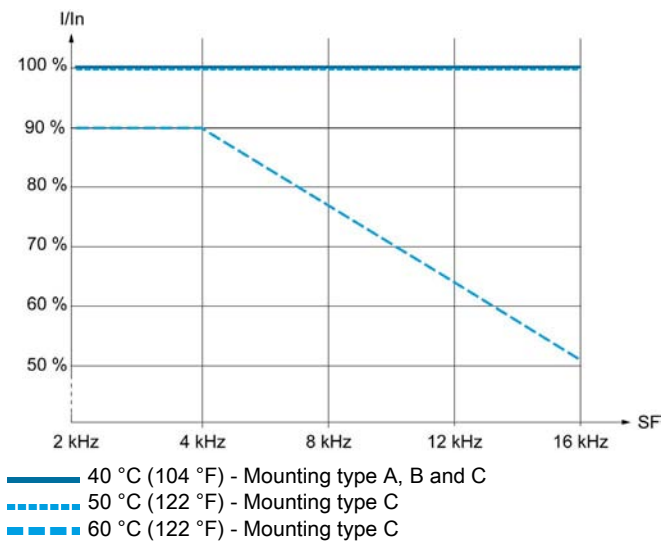

### ATV320D11S6C and ATV320D15S6C

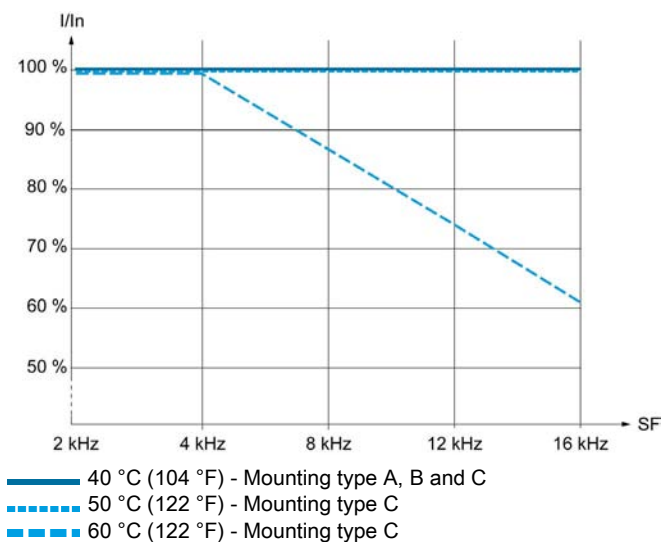

## Power Dissipated For Enclosed Drives and Required Air Flow

Catalog Number	Frame Size	Cooling type	Power Dissipated (1)	Air flow (2)	
			(W)	(m <sup>3</sup> )	(yd <sup>3</sup> )
ATV320U02M2B	1B	Forced cooling	25	9.4	12.3
ATV320U04M2B	1B	Forced cooling	38	9.4	12.3
ATV320U06M2B	1B	Forced cooling	42	9.4	12.3
ATV320U07M2B	1B	Forced cooling	51	9.4	12.3
ATV320U11M2B	2B	Forced cooling	64	11.3	14.8
ATV320U15M2B	2B	Forced cooling	81	11.3	14.8
ATV320U22M2B	2B	Forced cooling	102	11.3	14.8
ATV320U02M2C	1C	Fanless	22	–	–
ATV320U04M2C	1C	Fanless	32	–	–
ATV320U06M2C	1C	Fanless	42	–	–
ATV320U07M2C	1C	Fanless	48	–	–
ATV320U11M2C	2C	Forced cooling	66	16	21
ATV320U15M2C	2C	Forced cooling	82	16	21
ATV320U22M2C	2C	Forced cooling	110	16	21
ATV320U02M3C	1C	Fanless	21	–	–
ATV320U04M3C	1C	Fanless	34	–	–
ATV320U06M3C	1C	Fanless	40	–	–
ATV320U07M3C	1C	Fanless	49	–	–
ATV320U11M3C	2C	Forced cooling	66	15	20
ATV320U15M3C	2C	Forced cooling	69	15	20
ATV320U22M3C	2C	Forced cooling	92	15	20
ATV320U30M3C	3C	Forced cooling	109	16.4	21.5
ATV320U40M3C	3C	Forced cooling	141	16.4	21.5
ATV320U55M3C	4C	Forced cooling	261	60	78.5
ATV320U75M3C	4C	Forced cooling	324	60	78.5
ATV320D11M3C	5C	Forced cooling	528	156	204
ATV320D15M3C	5C	Forced cooling	545	156	204
ATV320U04N4B	1B	Forced cooling	27	18	23.5
ATV320U06N4B	1B	Forced cooling	31	18	23.5
ATV320U07N4B	1B	Forced cooling	37	18	23.5
ATV320U11N4B	1B	Forced cooling	50	18	23.5
ATV320U15N4B	1B	Forced cooling	63	18	23.5
ATV320U22N4B	2B	Forced cooling	78	37.7	49.3
ATV320U30N4B	2B	Forced cooling	100	37.7	49.3
ATV320U40N4B	2B	Forced cooling	125	37.7	49.3
ATV320U04N4C	2C	Forced cooling	28	18	23.5
ATV320U06N4C	2C	Forced cooling	33	18	23.5
ATV320U07N4C	2C	Forced cooling	39	18	23.5
ATV320U11N4C	2C	Forced cooling	47	18	23.5
ATV320U15N4C	2C	Forced cooling	61	18	23.5
ATV320U22N4C	3C	Forced cooling	76	37.7	49.3
ATV320U30N4C	3C	Forced cooling	94	37.7	49.3
ATV320U40N4C	3C	Forced cooling	112	37.7	49.3
ATV320U55N4B	4B	Forced cooling	233	60	78.5
ATV320U75N4B	4B	Forced cooling	263	60	78.5

**(1)** Power dissipated at nominal current  
**(2)** Minimum air flow rate required

Catalog Number	Frame Size	Cooling type	Power Dissipated (1)	Air flow (2)	
			(W)	(m <sup>3</sup> )	(yd <sup>3</sup> )
ATV320D11N4B	5B	Forced cooling	403	156	204
ATV320D15N4B	5B	Forced cooling	480	156	204
ATV320U07S6C	2C	Forced cooling	31	18	23.5
ATV320U15S6C	2C	Forced cooling	40	18	23.5
ATV320U22S6C	3C	Forced cooling	50	37.7	49.3
ATV320U40S6C	3C	Forced cooling	72	37.7	49.3
ATV320U55S6C	4C	Forced cooling	114	60	78.5
ATV320U75S6C	4C	Forced cooling	136	60	78.5
ATV320D11S6C	5C	Forced cooling	197	156	204
ATV320D15S6C	5C	Forced cooling	228	156	20.4
<b>(1)</b> Power dissipated at nominal current					
<b>(2)</b> Minimum air flow rate required					

---

## Mounting

### Mounting Holes and Screws

Fixation by screws is required for all drives ratings:

- Number of holes: Use the 4 mounting holes.
- Use of only 2 holes is possible (left top and right bottom) on frame sizes 1B, 2B, 1C, and 2C.

Top hole



Frame Size	Top Holes a mm (in.)	Top Holes b (if any) mm (in.)	Bottom holes mm (in.)	Recommended Screws
1B	5 (0.2)	–	–	M4
2B	5 (0.2)	–	–	M4
1C	5 (0.2)	–	5 (0.2)	M4
2C	5 (0.2)	–	5 (0.2)	M4
4B	5 (0.2)	11 (0.43)	5 (0.2)	M4
5B	6 (0.24)	14 (0.55)	6 (0.24)	M5
3C	5 (0.2)	–	5 (0.2)	M4
4C	5 (0.2)	11 (0.43)	5 (0.2)	M4
5C	6 (0.24)	14 (0.55)	6 (0.24)	M5

**NOTE:** Screws are not delivered with the product.





---

# Chapter 4

## Drive wiring

---

### What Is in This Chapter?

This chapter contains the following topics:

Topic	Page
Wiring Instructions	50
Cable Length Instructions	53
Wiring Diagrams	54
Operation on an IT System	58
Disconnecting the Built-in EMC Filter	58
Sink / Source Switch Configuration	62
Characteristics of the Power Part Terminals	64
Wiring the Power Part	67
EMC plate assembly fitting	82
Electromagnetic Compatibility	85
Control Terminals Electrical Data	87
Arrangement and Characteristics of Control Block Terminals and Communication and I/O Ports	89
Wiring The Control Part	90

## Wiring Instructions

### General Instructions

Drive systems may perform unexpected movements because of incorrect wiring, incorrect settings, incorrect data or other errors.

### **⚠ WARNING**

#### UNANTICIPATED EQUIPMENT OPERATION

- Carefully install the wiring in accordance with the EMC requirements.
- Do not operate the product with unknown or unsuitable settings or data.
- Perform a comprehensive commissioning test.

**Failure to follow these instructions can result in death, serious injury, or equipment damage.**

### **⚡ ⚠ DANGER**

#### HAZARD OF FIRE OR ELECTRIC SHOCK

- Wire cross sections and tightening torques must comply with the specifications provided in this document
- Do not use multi-conductor cables without cable lugs for any connection with a voltage higher than 25 Vac.

**Failure to follow these instructions will result in death or serious injury.**

The product has a leakage current greater than 3.5 mA. If the protective ground connection is interrupted, a hazardous touch current may flow if the product is touched.

### **⚡ ⚠ DANGER**

#### ELECTRIC SHOCK CAUSED BY HIGH LEAKAGE CURRENT

- Verify compliance with all local and national electrical code requirements as well as all other applicable regulations with respect to grounding of the entire drive system.

**Failure to follow these instructions will result in death or serious injury.**

### **⚠ WARNING**

#### INSUFFICIENT PROTECTION AGAINST OVERCURRENTS

- Properly rated overcurrent protective devices must be used.
- Use the fuses specified in the annex provided with the drive.
- Do not connect the product to a supply mains whose short-circuit current rating (SCCR) exceeds the permissible value specified in the annex provided with the drive.

**Failure to follow these instructions can result in death, serious injury, or equipment damage.**

- Ensure that the resistance to ground is 1 Ohm or less.
- When grounding several drives, you must connect each one directly, as shown in the above figure.
- Do not loop ground cables or connect them in series.

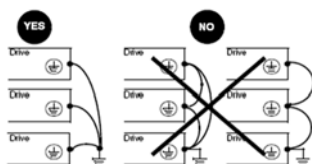

## Cable Characteristics

If you are using cables longer than 50 m (164 ft) between the drive and the motor, add output filters (for more details refer to the catalog).

Use a shielded cable to meet the requirements of Category C2 or C3 according to the standard IEC 61800-3, except when using a sinus filter. In this case, the use of a non-shielded motor cable is possible.

To limit the currents in common mode, use common mode output filters (ferrite) in order to reduce the circulating currents in the motor windings.

Standard linear capacity cables can be used with Altivar Machine. Use of cables with lower linear capacity could increase cable length performances.

The overvoltage limitation function [**Motor surge limit.**]  $5 \leq L$  enables you to increase the cable length while decreasing the torque performances (refer to Programming manual (*see page 9*)).

## Residual Current Device

Direct current can be introduced in the protective ground conductor of this drive. If a residual current device (RCD / GFCI) or a residual current monitor (RCM) is used for additional protection against direct or indirect contact, the following specific types must be used.

### WARNING

#### **DIRECT CURRENT CAN BE INTRODUCED INTO THE PROTECTIVE GROUND CONDUCTOR**

- Use a Type A Residual Current Device (RCD / GFCI) or a Residual Current Monitor (RCM) for single-phase drives connected to a phase and to the neutral conductor.
- Use a Type B Residual Current Device (RCD / GFCI) or a Residual Current Monitor (RCM) that has approval for use with frequency inverters and is sensitive to all types of current for three-phase devices and for single-phase devices not connected to a phase and the neutral conductor.

**Failure to follow these instructions can result in death, serious injury, or equipment damage.**

Further conditions for use of a residual current device:

- The drive has an increased leakage current at the moment power is applied. Use a residual current device (RCD / GFCI) or a residual current monitor (RCM) with a response delay.
- High-frequency currents must be filtered.

Choose a suitable model integrating:

- High frequency current filtering,
- A time delay that helps to prevent a triggering of the upstream device caused by the load from stray capacitance on power-on. The time delay is not available for 30 mA device; in this case, choose devices with immunity against nuisance triggering.

Due to high leakage current in standard operation, we recommend choosing at least a 300 mA device.

If the installation requires a residual current device less than 300 mA, it can be possible to use a device lower than 300 mA by removing the screws according to the instructions given in the **Operation on an IT or Corner Grounded System** section (*see page 58*).

If the installation includes several drives, provide one residual current device per drive.

**NOTICE**

**DESTRUCTION DUE TO INCORRECT WIRING**

- Before switching on and configuring the product, verify that it is properly wired.

**Failure to follow these instructions can result in equipment damage.**

**  DANGER**

**ELECTRIC SHOCK CAUSED BY INSUFFICIENT GROUNDING**

- Verify compliance with all local and national electrical code requirements as well as all other applicable regulations with respect to grounding of the entire drive system.
- Ground the drive system before applying voltage.
- The cross section of the protective ground conductor must comply with the applicable standards.
- Do not use conduits as protective ground conductors; use a protective ground conductor inside the conduit.
- Do not consider cable shields to be protective ground conductors.

**Failure to follow these instructions will result in death or serious injury.**

Tighten the grounding screws according to the instructions given in the Ground Cables section ([see page 64](#)).

---

## Cable Length Instructions

### Long Cable Lengths Consequences

When drives are used with motors, a combination of fast switching transistors and long motor cables can even cause peak voltages up to twice the DC link voltage. This high peak voltage can cause premature aging of motor winding insulation which leads to motor breakdown.

The overvoltage limitation function will enable to increase the cable length while decreasing the torque performances.

### Length Of Motor Cables

Because of the permitted mains disturbances, the allowed overvoltages at the motor, the occurring bearing currents and the permitted heat losses the distance between inverter and motor(s) is limited.

The maximum distance heavily depends on the used motors (insulation material), the type of motor cable used (shielded/unshielded), the cable laying (cable channel, underground installation...) as well as from the used options.

### Dynamic Voltage Load Of The Motor

Overvoltages at the motor terminals result from reflection in the motor cable. Basically the motors are stressed with measurable higher voltage peaks from a motor cable length of 10 m. With the length of the motor cable also the value of overvoltage increases.

The steep edges of the switching impulses at the output side of the frequency inverter lead to a further load of the motors. The slew rate of the voltage is typically over 5 kV/μs but it decreases with the length of the motor cable

Load of the motor with overvoltage and slew rate when using conventional drive

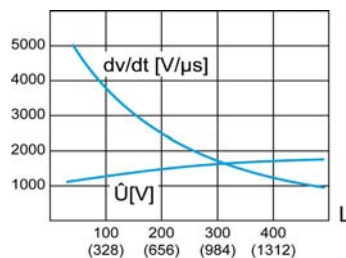

L Length of motor cables in meters (feet)

### Corrective Actions Overview

A number of simple measures can be taken to help enhance the motor life time:

- Specification of a motor designed for speed drive applications (IEC60034-25 B or NEMA 400 should be prescribed).
- Reduce to a minimum the distance between motor and drive.
- Use unshielded cables.
- Reduce the drive switching frequency (a reduction to 2.5 kHz is recommended.)

### Additional Information

Further detailed technical information is available in the following white paper *An Improved Approach for Connecting VSD and Electric Motors* available on [www.schneider-electric.com](http://www.schneider-electric.com).

## Wiring Diagrams

### Control Block Wiring Diagram

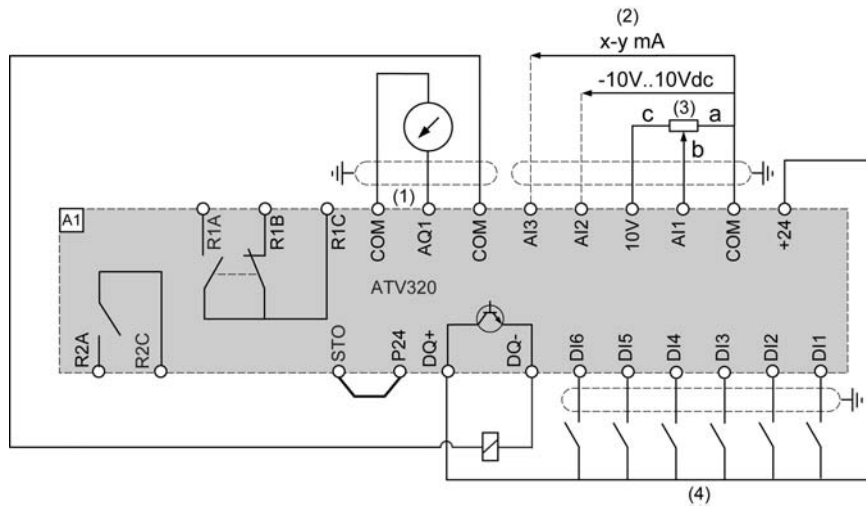

- (1) Analog output
- (2) Analog inputs
- (3) Potentiometer SZ1RV1202 (2.2 kΩ) or similar (10 kΩ maximum)
- (4) Digital Inputs - Shielding instructions are given in the Electromagnetic Compatibility section

### Single or Three-phase Power Supply - Diagram With Line Contactor

Connection diagrams conforming to standards ISO13849 category 1 and IEC/EN 61508 capacity SIL1, stopping category 0 in accordance with standard IEC/EN 60204-1.

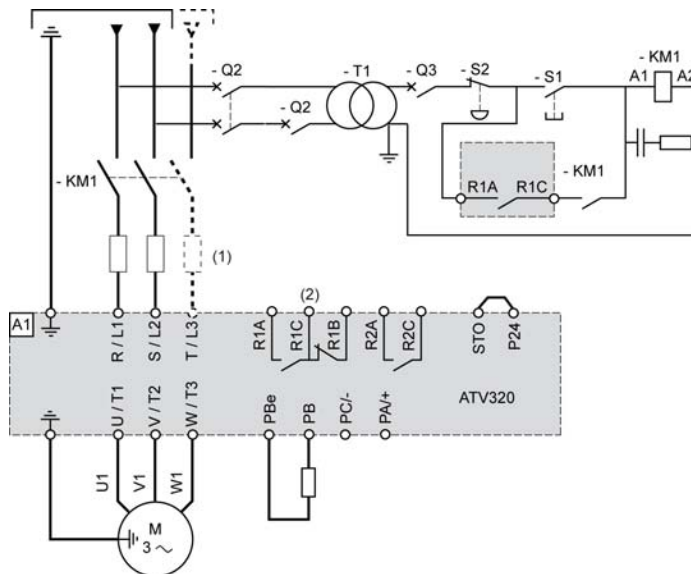

- (1) Line choke (if used).
- (2) Use relay output R1 set to operating state Fault to switch Off the product once an error is detected.

## Single or Three-phase Power Supply - Diagram With Downstream Contactor

If a Run command is executed while the downstream contactor between the drive and the motor is still open, there may be residual voltage at the output of the drive. This can cause an incorrect estimation of the motor speed when the contacts of the downstream contactor are closed. This incorrect estimation of the motor speed can lead to unanticipated equipment operation or to equipment damage.

In addition, there may be overvoltage at the output of the drive if the power stage is still enabled when the downstream contactor between the drive and the motor opens.

### **⚠ WARNING**

#### **UNANTICIPATED EQUIPMENT OPERATION OR EQUIPMENT DAMAGE**

If a downstream contactor is used between the drive and the motor, verify the following:

- The contacts between the motor and the drive must be closed before a Run command is executed.
- The power stage must not be enabled when the contacts between the motor and the drive open.

**Failure to follow these instructions can result in death, serious injury, or equipment damage.**

Connection diagrams conforming to standards EN 954-1 category 1 and IEC/EN 61508 capacity SIL1, stopping category 0 in accordance with standard IEC/EN 60204-1.

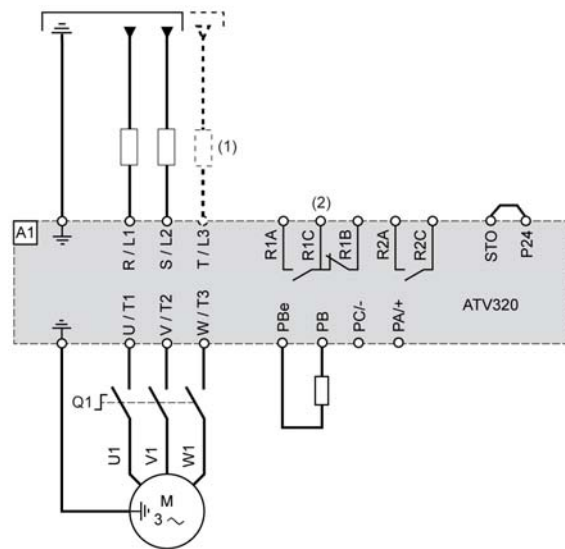

(1) Line choke (if used)

(2) Use relay output R1 set to operating state Fault to switch Off the product once an error is detected.

## Diagram with Preventa Safety Module

Connection diagrams conforming to standards EN 954-1 category 3 and IEC/EN 61508 capacity SIL2, stopping category 0 in accordance with standard IEC/EN 60204-1.

The connection diagram below is suitable for use with machines with a short freewheel stop time (machines with low inertia or high resistive torque).

When the emergency stop is activated, the drive power supply is cut immediately and the motor stops in freewheel, according to category 0 of standard IEC/EN 60204-1.

A contact on the Preventa XPS AC module must be inserted in the brake control circuit to engage it safely when the STO (Safe Torque Off) safety function is activated.

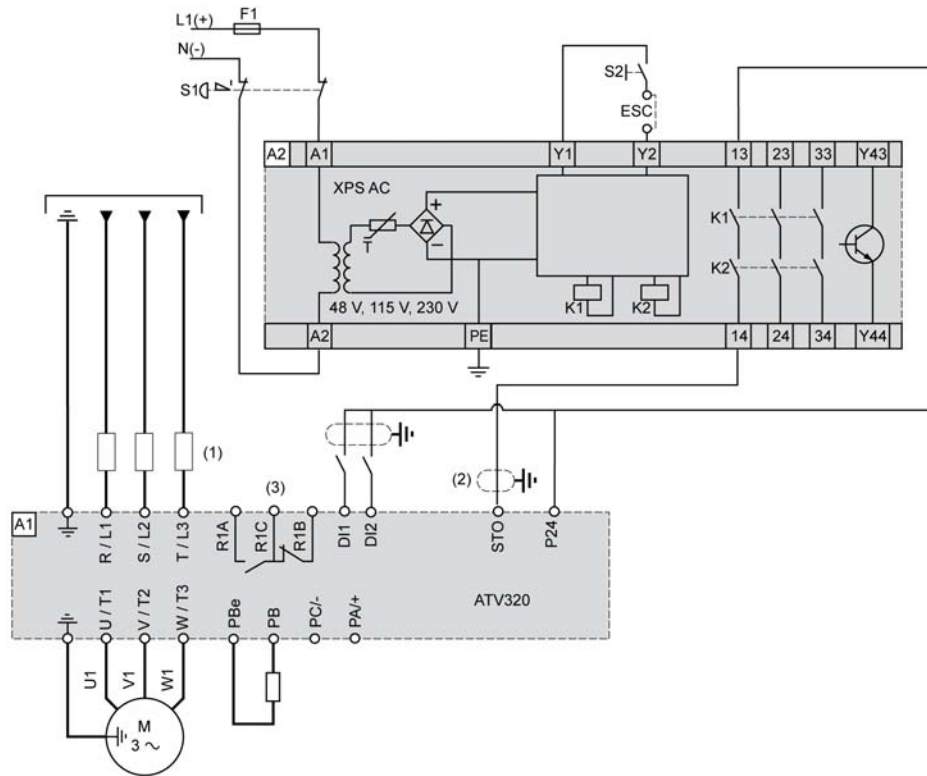

- (1) Line choke (if used)
- (2) It is essential to connect the shielding to the ground.
- (3) Operating state fault relay contacts, for remote signaling of drive status

The STO safety function integrated into the product can be used to implement an "EMERGENCY STOP" (IEC 60204-1) for category 0 stops.

With an additional, approved EMERGENCY STOP module, it is also possible to implement category 1 stops.

### Reset of STO function

The power stage is disabled and an error message is generated. The motor can no longer generate torque and coasts down without braking. A restart is possible after clearing manually the error with the **[Fault Reset]** function or after a power reset.



## Diagram without Preventa Safety Module

Connection diagrams conforming to standards EN 954-1 category 2 and IEC/EN 61508 capacity SIL1, stopping category 0 in accordance with standard IEC/EN 60204-1.

The connection diagram below is suitable for use with machines with a short freewheel stop time (machines with low inertia or high resistive torque).

When the emergency stop is activated, the drive power supply is cut immediately and the motor stops in freewheel, according to category 0 of standard IEC/EN 60204-1.

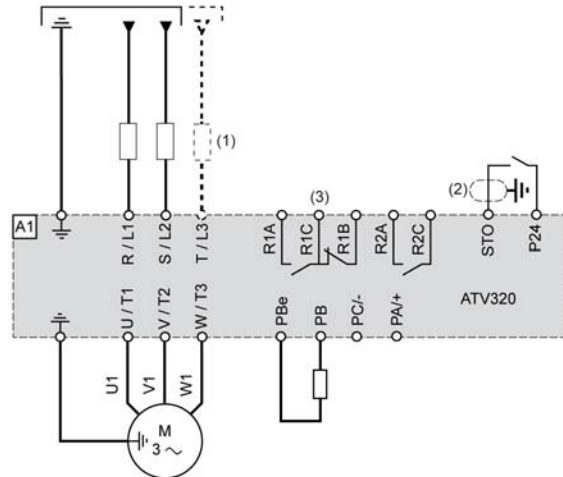

- (1) Line choke (if used)
- (2) It is essential to connect the shielding to the ground.
- (3) Operating state fault relay contacts, for remote signaling of drive status

The STO safety function integrated into the product can be used to implement an "EMERGENCY STOP" (IEC 60204-1) for category 0 stops.

## Operation on an IT System

### Definition

**IT system:** Isolated or impedance grounded neutral. Use a permanent insulation monitoring device compatible with nonlinear loads, such as an XM200 type or equivalent.

**Corner grounded system:** System with one phase grounded.

### Operation

<b><i>NOTICE</i></b>
<b>RISK OF DAMAGE TO THE DRIVE</b>
If the drive is used on an IT system, the built-in EMC filter must be disconnected as described in this manual.
<b>Failure to follow these instructions can result in equipment damage.</b>

## Disconnecting the Built-in EMC Filter

### Filter Disconnection

 <b>DANGER</b>
<b>HAZARD OF ELECTRIC SHOCK, EXPLOSION OR ARC FLASH</b>
Read and understand the instructions in <b>Safety Information</b> chapter before performing any procedure in this chapter.
<b>Failure to follow these instructions will result in death or serious injury.</b>

The drives have a built-in EMC filter (\*). As a result they exhibit leakage current to ground. If the leakage current creates compatibility problems with your installation (residual current device or other), then you can reduce the leakage current by deactivating the Y capacitors as shown below. In this configuration the product does not meet the EMC requirements according to the standard IEC 61800-3.

(\*): Except ATV320...M3C drives (for 3-phase 200...240 V supply mains) and ATV320...S6C drives (for 3-phase 525...600 V supply mains).

### Setting

This table shows the setting according to the drives

Drive type	Ratings	Setting
ATV320...B	All	IT jumper
ATV320...C	1-phase 200 V up to 2.2 kW	IT jumper
	3-phase 400 V up to 4 kW	Screw
	3-phase 200 V (1)	–
	3-phase 600 V (1)	–
<b>(1)</b> These drives do not include an EMC filter.		

### Setting on ATV320U02M2B...U22M2B, ATV320U04N4B...U40N4B drives

On frame sizes 1B and 2B the IT jumper is located on top of the product, behind the GV2 circuit-breaker adapter mounting screws.

Apply the following instructions to set the drive to operate or not on an IT or Corner grounded system

Step	Action
1	The switch is <b>factory set</b> to the  position shown on detail ①
2	To disconnect the built-in EMC filter position the switch as shown on detail ②

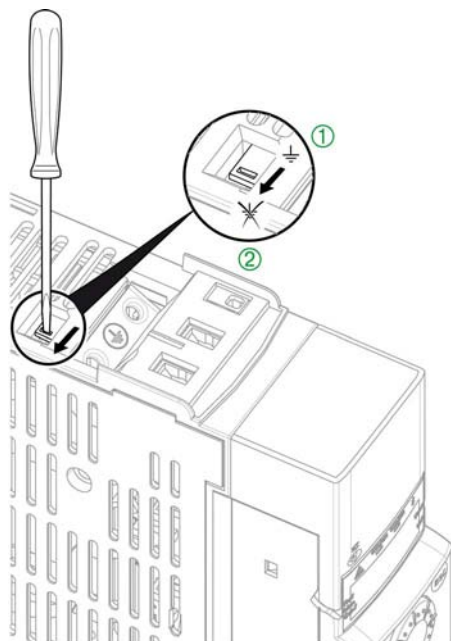

### Setting on ATV320U55N4B...D15N4B drives

On frame sizes 4B4, 5B5 the IT jumper is located on front side, behind the power terminals protective cover, on the left-hand side of the power input terminals.

Apply the following instructions to set the drive to operate or not on an IT or Corner grounded system

Step	Action
1	Remove the terminal cover ( <i>see page 70</i> )
2	The switch is <b>factory set</b> to the  position shown on detail ①
3	To disconnect the built-in EMC filter position the switch as shown on detail ②
4	Refit the terminal cover

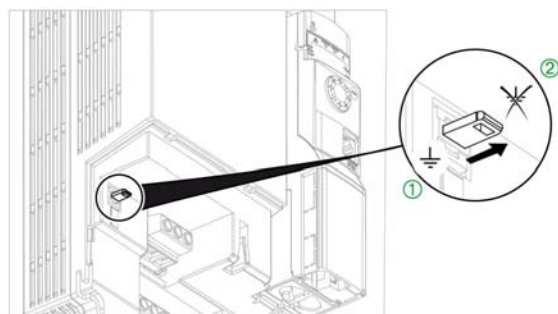

### Setting on ATV320U02M2C...U07M2C drives

Apply the following instructions to set the drive to operate or not on an IT or Corner grounded system

Step	Action
1	Remove the power terminal cover (see page 72)
2	The switch is <b>factory set</b> to the  position shown on detail ①
3	To disconnect the built-in EMC filter position the switch as shown on detail ②
4	Refit the front cover

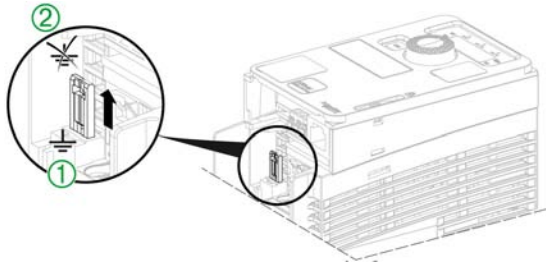

### Setting on ATV320U11M2C...U22M2C drives

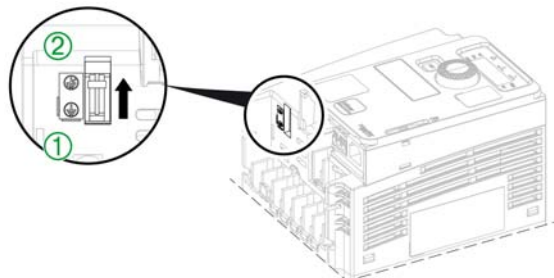

Apply the following instructions to set the drive to operate or not on an IT or Corner grounded system

Step	Action
1	Remove the power terminal cover (see page 74)
2	The switch is <b>factory set</b> to the  position shown on detail ①
3	To disconnect the built-in EMC filter position the switch as shown on detail ②
4	Refit the front cover



### Setting on ATV320U04N4C...U15N4C drives

Apply the following instructions to set the drive to operate or not on an IT or Corner grounded system

Step	Action
1	Remove the power terminal cover (see page 74)
2	The screw is <b>factory set</b> to the  position the screws as shown on detail ①
3	To disconnect the built-in EMC filter, remove the screw from its location and set it to the  position as shown on detail ②
4	Refit the front cover

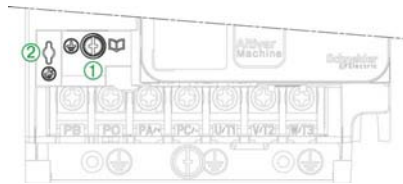

#### NOTE:

- Use only the screws supplied.
- Do not operate the drive with setting screws removed.



### Setting on ATV32U22N4C...U40N4C drives

Apply the following instructions to set the drive to operate or not on an IT or Corner grounded system

Step	Action
1	Remove the power terminal cover (see page 76)
2	The screw is <b>factory set</b> to the  position the screws as shown on detail ①
3	To disconnect the built-in EMC filter, remove the screw from its location and set it to the  position as shown on detail ②
4	Refit the front cover

#### NOTE:

- Use only the screws supplied.
- Do not operate the drive with setting screws removed.

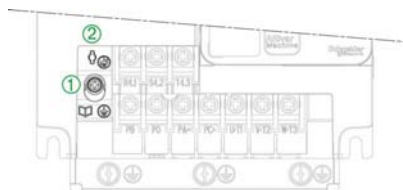

## Sink / Source Switch Configuration

### ⚠ WARNING

#### UNANTICIPATED EQUIPMENT OPERATION

- If the drive is set to **Sink Int** or **Sink Ext**, do not connect the **0 V** terminal to ground or to protective ground.
- Verify that accidental grounding of digital inputs configured for sink logic, caused, for example, by damage to the signal cables, cannot occur.
- Follow all applicable standards and directives such as NFPA 79 and EN 60204 for proper control circuit grounding practices.

**Failure to follow these instructions can result in death, serious injury, or equipment damage.**

The switch is used to adapt the operation of the digital inputs to the technology of the programmable controller outputs. To access the switch, follow the Access to control Terminals procedure. The switch is located below the control terminals (*see page 89*).

- Set the switch to **Source** (factory setting) if using PLC outputs with PNP transistors.
- Set the switch to **Ext** if using PLC outputs with NPN transistors.

### Switch Set to SRC (Source) Position Using the Output Power Supply for the Digital Inputs

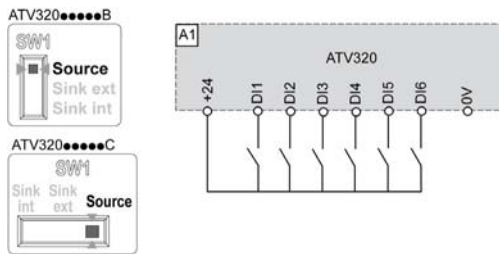

### Switch Set to SRC (Source) Position and Use of an External Power Supply for the DIs

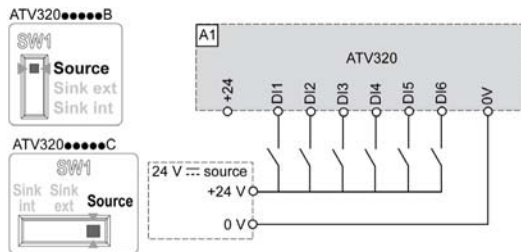

### Switch Set to SK (Sink) Position Using the Output Power Supply for the Digital Inputs

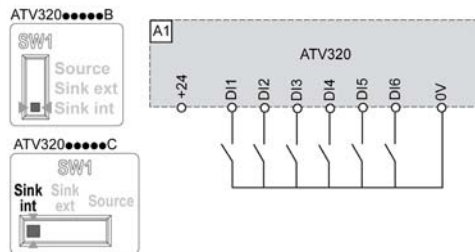

## Switch Set to EXT Position Using an External Power Supply for the DIs

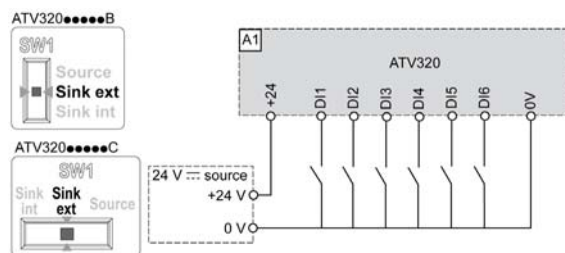

### NOTE:

- STO input is also connected by default on a 24 Vdc terminal. If the external power supply is switched off, the function STO will be triggered.
- To avoid triggering the STO function when switching-on the product, the external power supply must be previously switched on.

## Characteristics of the Power Part Terminals

### Ground Cables

Ground cable cross sections of input and output ground cables are the same as those given for the input and output cables.

Minimum cross section of protective ground cable is 10 mm<sup>2</sup> (AWG 8) for CU cable and 16 mm<sup>2</sup> (AWG 6) for AL cable.

Due to high leakage currents an additional PE connection must be wired.

### Ground Terminals Screws Tightening Torques

Tightening torques according to frame size

- Frame sizes B: 0.7...0.8 N·m (6.2...7.1 lb.in)
- Frame size 1C, 2C:
  - Main grounding screw (M5): 2.4 N·m (21.1 lb.in)
  - Input/Output grounding screws (M4): 1.4 N·m (12.4 lb.in)
- Frame size 3C, 4C, 5C: 2.4 N·m (21.1 lb.in)

### Frame Size 1

#### Supply and Output Terminals

ATV320	Supply Terminals (L1, L2, L3)			Output Terminals (U, V, W)		
	Wire Cross Section		Tightening Torque	Wire Cross Section		Tightening Torque
	Minimum	Maximum (*)	Rated	Minimum	Maximum (*)	Rated
	mm <sup>2</sup> (AWG)	mm <sup>2</sup> (AWG)	N·m (lb.in)	mm <sup>2</sup> (AWG)	mm <sup>2</sup> (AWG)	N·m (lb.in)
U02M2B, U04M2B, U06M2B, U07M2B, U02M3C, U04M3C, U06M3C, U07M3C	1.5 (14)	4 (10)	0.6 (5.3)	1.5 (14)	1.5 (14)	0.7...0.8 (6.2...7.1)
U02M2C, U04M2C, U06M2C, U07M2C	2.5 (14)	4 (12)	1 (8.9)	2.5 (14)	4 (12)	1 (8.9)
U04N4B, U06N4B, U07N4B, U11N4B, U15N4B	1.5 (14)	4 (10)	0.6 (5.3)	1.5 (14)	2.5 (12)	0.7...0.8 (6.2...7.1)

(\*) maximum permissible cross section of the terminal



## Frame Size 2

### Supply and Output Terminals

ATV320	Supply Terminals (L1, L2, L3)			Output Terminals (U, V, W)		
	Wire Cross Section		Tightening Torque	Wire Cross Section		Tightening Torque
	Minimum	Maximum (*)	Rated	Minimum	Maximum (*)	Rated
	mm <sup>2</sup> (AWG)	mm <sup>2</sup> (AWG)	N·m (lb.in)	mm <sup>2</sup> (AWG)	mm <sup>2</sup> (AWG)	N·m (lb.in)
U11M2B	2.5 (12)	4 (10)	0.6 (5.3)	1.5 (14)	1.5 (14)	0.7...0.8 (6.2...7.1)
U15M2B	2.5 (10)	4 (10)	0.6 (5.3)	1.5 (14)	1.5 (14)	0.7...0.8 (6.2...7.1)
U22M2B	4 (10)	4 (10)	0.6 (5.3)	1.5 (14)	1.5 (14)	0.7...0.8 (6.2...7.1)
U04N4C, U06N4C, U07N4C, U07S6C, U11N4C, U15N4C, U15S6C, U11M3C, U15M3C	2.5 (14)	6 (10)	1.4 (12.4)	2.5 (14)	6 (10)	1.4 (12.4)
U11M2C, U15M2C	4 (12)	6 (10)	1.4 (12.4)	4 (12)	6 (10)	1.4 (12.4)
U22M3C	4 (12)	6 (10)	1.4 (12.4)	2.5 (14)	6 (10)	1.4 (12.4)
U22M2C	6 (10)	6 (10)	1.4 (12.4)	6 (10)	6 (10)	1.4 (12.4)
U22N4B, U30N4B	1.5 (14)	4 (10)	0.6 (5.3)	1.5 (14)	2.5 (12)	0.8 (7.1)
U40N4B	2.5 (12)	4 (10)	0.6 (5.3)	1.5 (14)	2.5 (12)	0.8 (7.1)
(*) maximum permissible cross section of the terminal						

## Frame Size 3

### Supply and Output Terminals

ATV320	Supply Terminals (L1, L2, L3)			Output Terminals (U, V, W)		
	Wire Cross Section		Tightening Torque	Wire Cross Section		Tightening Torque
	Minimum	Maximum (*)	Rated	Minimum	Maximum (*)	Rated
	mm <sup>2</sup> (AWG)	mm <sup>2</sup> (AWG)	N·m (lb.in)	mm <sup>2</sup> (AWG)	mm <sup>2</sup> (AWG)	N·m (lb.in)
U22N4C, U30N4C, U22S6C, U40S6C	2.5 (14)	6 (10)	1.4 (12.4)	2.5 (14)	6 (10)	1.4 (12.4)
U40N4C	4 (12)	6 (10)	1.4 (12.4)	4 (14)	6 (10)	1.4 (12.4)
U30M3C	6 (10)	6 (10)	1.4 (12.4)	4 (12)	6 (10)	1.4 (12.4)
U40M3C	6 (10)	6 (10)	1.4 (12.4)	6 (10)	6 (10)	1.4 (12.4)
(*) maximum permissible cross section of the terminal						

## Frame Size 4

### Supply and Output Terminals

ATV320	Supply Terminals (L1, L2, L3)			Output Terminals (U, V, W)		
	Wire Cross Section		Tightening Torque	Wire Cross Section		Tightening Torque
	Minimum	Maximum (*)	Rated	Minimum	Maximum (*)	Rated
	mm <sup>2</sup> (AWG)	mm <sup>2</sup> (AWG)	N·m (lb.in)	mm <sup>2</sup> (AWG)	mm <sup>2</sup> (AWG)	N·m (lb.in)
U55S6C	2.5 (14)	16 (6)	2.4 (20.8)	2.5 (14)	16 (6)	2.4 (20.8)
U55N4B	4 (10)	16 (6)	1.2...1.5 (10.6...13.3)	2.5 (12)	16 (6)	1.2...1.5 (10.6...13.3)
U55M3C	4 (10)	16 (6)	1.2...1.5 (10.6...13.3)	2.5 (12)	2.5 (12)	1.2...1.5 (10.6...13.3)
U75S6C	4 (12)	16 (6)	2.4 (20.8)	4 (12)	16 (6)	2.4 (20.8)
U75N4B	6 (8)	16 (6)	1.2...1.5 (10.6...13.3)	2.5 (10)	16 (6)	1.2...1.5 (10.6...13.3)
U75M3C	6 (8)	16 (6)	1.2...1.5 (10.6...13.3)	2.5 (10)	2.5 (10)	1.2...1.5 (10.6...13.3)

(\*) maximum permissible cross section of the terminal

## Frame Size 5

### Supply and Output Terminals

ATV320	Supply Terminals (L1, L2, L3)			Output Terminals (U, V, W)		
	Wire Cross Section		Tightening Torque	Wire Cross Section		Tightening Torque
	Minimum	Maximum (*)	Rated	Minimum	Maximum (*)	Rated
	mm <sup>2</sup> (AWG)	mm <sup>2</sup> (AWG)	N·m (lb.in)	mm <sup>2</sup> (AWG)	mm <sup>2</sup> (AWG)	N·m (lb.in)
D11S6C	6 (10)	16 (6)	2.4 (20.8)	6 (10)	16 (6)	2.4 (20.8)
D15S6C	6 (10)	16 (6)	2.4 (20.8)	6 (10)	16 (6)	2.4 (20.8)
D11N4B	10 (8)	16 (6)	1.2...1.5 (10.6...13.3)	6 (8)	16 (6)	1.2...1.5 (10.6...13.3)
D11M3C	10 (8)	16 (6)	1.2...1.5 (10.6...13.3)	6 (8)	16 (6)	1.2...1.5 (10.6...13.3)
D15N4B	16 (6)	16 (6)	1.2...1.5 (10.6...13.3)	6 (8)	16 (6)	1.2...1.5 (10.6...13.3)
D15M3C	16 (6)	16 (6)	1.2...1.5 (10.6...13.3)	10 (8)	10 (8)	1.2...1.5 (10.6...13.3)

(\*) maximum permissible cross section of the terminal

## Wiring the Power Part



### HAZARD OF ELECTRIC SHOCK, EXPLOSION OR ARC FLASH

Verify that the cables are properly installed as specified in the Characteristics of the Power Part Terminals section.

**Failure to follow these instructions will result in death or serious injury.**

## Functions of the Power Terminals

Terminal	Function	For Altivar 320
⏚	Ground terminal	All ratings and Frame sizes
R/L1 - S/L2/N	Power supply	ATV320••••M2•
R/L1 - S/L2 - T/L3		ATV320••••N4•, ATV320••••M3C
P0	Output to braking resistor (+ polarity) (1)	ATV320•••••C
PB	Output to braking resistor (1)	All ratings and Frame sizes
PBe	Output to braking resistor (+ polarity) (1)	ATV320•••••B
PA/+	DC bus + polarity	Frame sizes 1C, 2C, 3C, 4 and 5
PC/-	DC bus - polarity	Frame sizes 1C, 2C, 3C, 4 and 5
U/T1 - V/T2 - W/T3	Outputs to the motor	All ratings and Frame sizes
(1) For further information about the braking resistor option, please refer to <a href="http://www.schneider-electric.com">www.schneider-electric.com</a> .		

## Braking Resistors

Braking resistors allow the drives to operate while braking to a standstill or during slowdown braking, by dissipating the braking energy. They enable maximum transient braking torque. For a detailed description and catalog numbers, refer to the Catalog and Braking resistors instruction sheet [NHA87388](#) on [www.schneider-electric.com](http://www.schneider-electric.com).

Minimum value of the resistor to be connected

Catalog Number	Minimum Value in $\Omega$	Catalog Number	Minimum Value in $\Omega$	Catalog Number	Minimum Value in $\Omega$
ATV320U02M••	40	ATV320D11M3C	5	ATV320U07N4•	80
ATV320U04M••	40	ATV320D15M3C	5	ATV320D11N4B	16
ATV320U06M••	40	ATV320U11N4•	54	ATV320D15N4B	16
ATV320U07M••	40	ATV320U15N4•	54	ATV320U07S6C	96
ATV320U11M••	27	ATV320U22N4•	54	ATV320U15S6C	64
ATV320U15M••	27	ATV320U30N4•	54	ATV320U22S6C	64
ATV320U22M••	25	ATV320U40N4•	36	ATV320U40S6C	44
ATV320U30M3C	16	ATV320U55N4B	27	ATV320U55S6C	34
ATV320U40M3C	16	ATV320U75N4B	27	ATV320U75S6C	23
ATV320U55M3C	8	ATV320U04N4•	80	ATV320D11S6C	24
ATV320U75M3C	8	ATV320U06N4•	80	ATV320D15S6C	24

## Access To The Terminals For Frame Size 1B and 2B

### DANGER

#### HAZARD OF ELECTRIC SHOCK, EXPLOSION OR ARC FLASH

Read and understand the instructions in **Safety Information** chapter before performing any procedure in this chapter.

**Failure to follow these instructions will result in death or serious injury.**

### DANGER

#### HAZARD OF ELECTRIC SHOCK, EXPLOSION, OR ARC FLASH

After wiring the power terminals, close the terminal cover.

**Failure to follow these instructions will result in death or serious injury.**

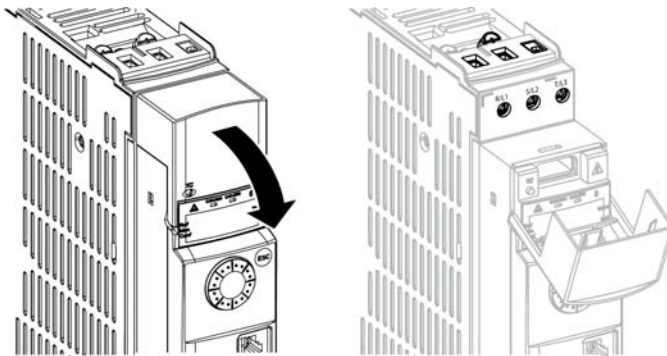

Apply the following instructions to access the power terminals on **frame sizes 1B and 2B** drives

Step	Action
1	Manually pull and tip up the wiring cover.
2	Motor and braking resistor terminals are located on the bottom of the drive.

## Access to the Braking Resistor Terminals on 1B and 2B Frame Sizes

Access to the braking resistor terminals is protected by breakable plastic parts. Use a screwdriver to remove these protective parts.

## Power Terminals Arrangement For Frame Size 1B

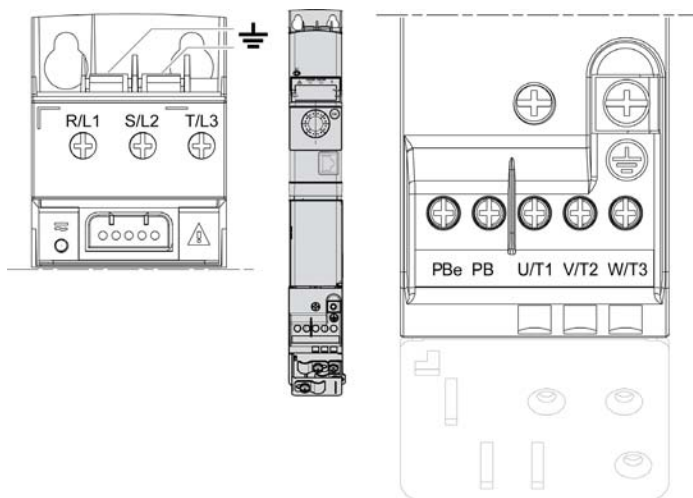

### Power Terminals Arrangement For Frame Size 2B

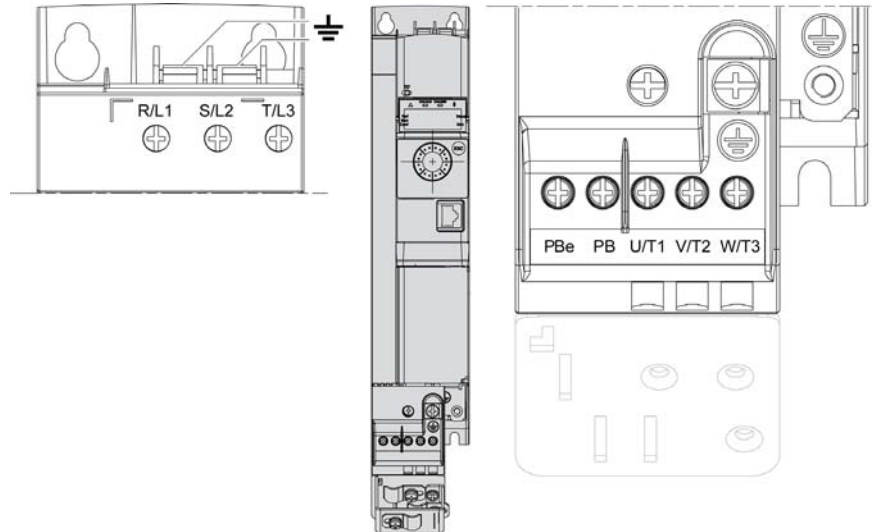

### Access To The DC Bus terminals For Frame Sizes 1B and 2B

**DANGER**

**HAZARD OF ELECTRIC SHOCK OR ARC FLASH**

- Use a screwdriver to remove the DC connector protective covers, instead of precision knife or scissors.
- If the DC bus terminals are not used, refit the DC bus protective plastic caps provided with the drive.

**Failure to follow these instructions will result in death or serious injury.**

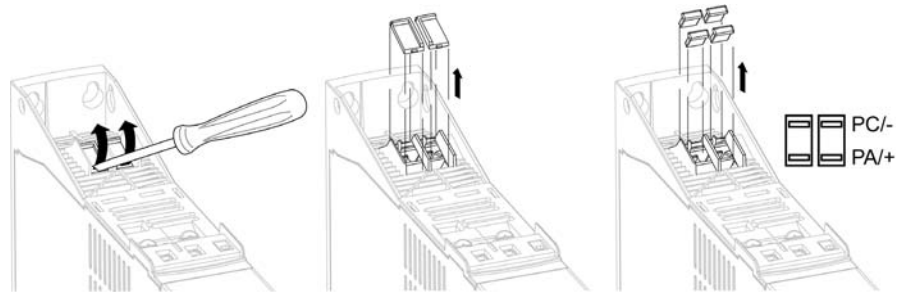

Perform the following operations to access the DC bus terminals

Step	Action
1	Break the protective covers, using a screwdriver.
2	Remove the protective covers
3	Remove the plastic protective caps from the terminals <b>NOTE:</b> When not connected, the DC bus terminals should be covered using the plastic caps. Once this is done the drive becomes IP20 again. If lost, the plastic caps are also available as spare parts.

## Access To The Terminals For Frame Size 4B and 5B

### **⚡ ⚠ DANGER**

#### HAZARD OF ELECTRIC SHOCK, EXPLOSION OR ARC FLASH

Read and understand the instructions in **Safety Information** chapter before performing any procedure in this chapter.

**Failure to follow these instructions will result in death or serious injury.**

### **⚡ ⚠ DANGER**

#### HAZARD OF ELECTRIC SHOCK, EXPLOSION, OR ARC FLASH

After wiring the power terminals, refit properly the terminal cover and the wiring cover to meet the required degree of protection.

**Failure to follow these instructions will result in death or serious injury.**

Power supply terminals, motor terminals and braking resistor terminals are located on the bottom of the drive.

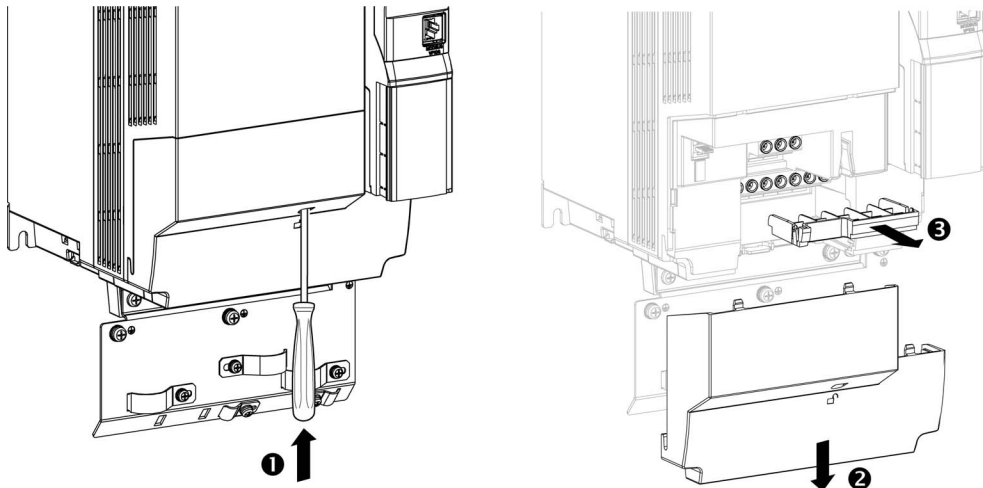

Apply the following instructions to access the power terminals on **frame sizes 4B and 5B** drives

Step	Action
1	Push the locking tab using a screwdriver.
2	Remove the wiring cover.
3	Remove the terminal cover

## Power Terminals Arrangement For Frame Size 4B

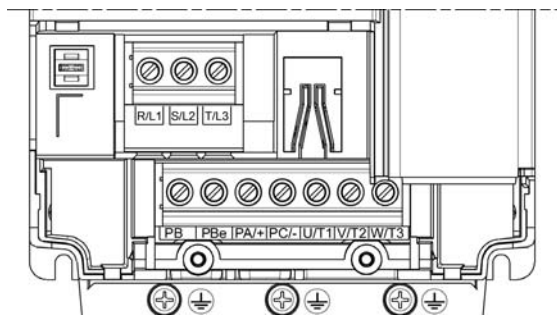

---

## Power Terminals Arrangement For Frame Size 5B

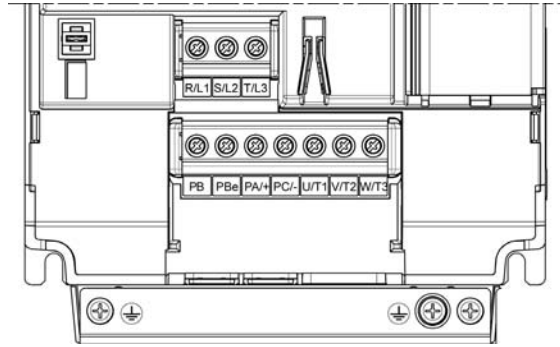

## Access To The Terminals For Frame Size 1C

### **DANGER**

#### HAZARD OF ELECTRIC SHOCK, EXPLOSION OR ARC FLASH

Read and understand the instructions in **Safety Information** chapter before performing any procedure in this chapter.

**Failure to follow these instructions will result in death or serious injury.**

### **DANGER**

#### HAZARD OF ELECTRIC SHOCK, EXPLOSION, OR ARC FLASH

After wiring the power terminals, refit properly the terminal cover and the wiring cover to meet the required degree of protection.

**Failure to follow these instructions will result in death or serious injury.**

Power supply terminals, motor terminals and braking resistor terminals are located on the bottom of the drive.

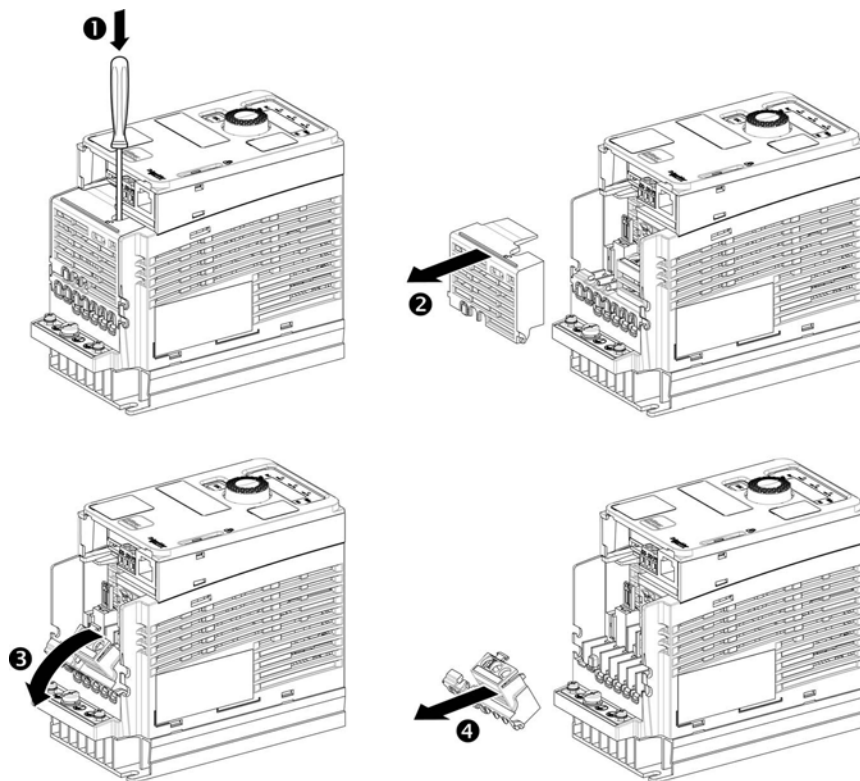

Apply the following instructions to access the power terminals on **frame sizes 1C** drives

Step	Action
1	Push the locking tab using a screwdriver.
2	Remove the wiring cover.
3	Incline the terminal cover
4	Remove the terminal cover



---

## Power Terminals Arrangement For Frame Size 1C

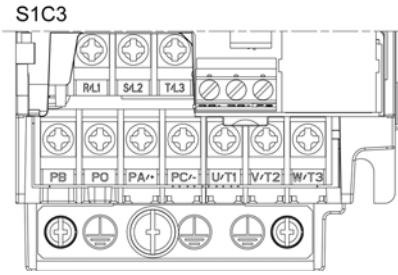
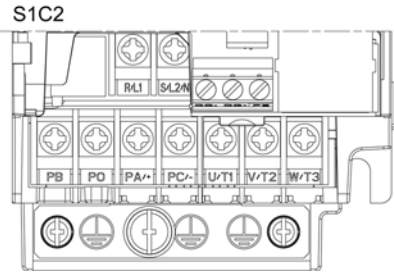

## Access To The Terminals For Frame Size 2C

### **DANGER**

#### HAZARD OF ELECTRIC SHOCK, EXPLOSION OR ARC FLASH

Read and understand the instructions in **Safety Information** chapter before performing any procedure in this chapter.

**Failure to follow these instructions will result in death or serious injury.**

### **DANGER**

#### HAZARD OF ELECTRIC SHOCK, EXPLOSION, OR ARC FLASH

After wiring the power terminals, refit properly the terminal cover and the wiring cover to meet the required degree of protection.

**Failure to follow these instructions will result in death or serious injury.**

Power supply terminals, motor terminals and braking resistor terminals are located on the bottom of the drive.

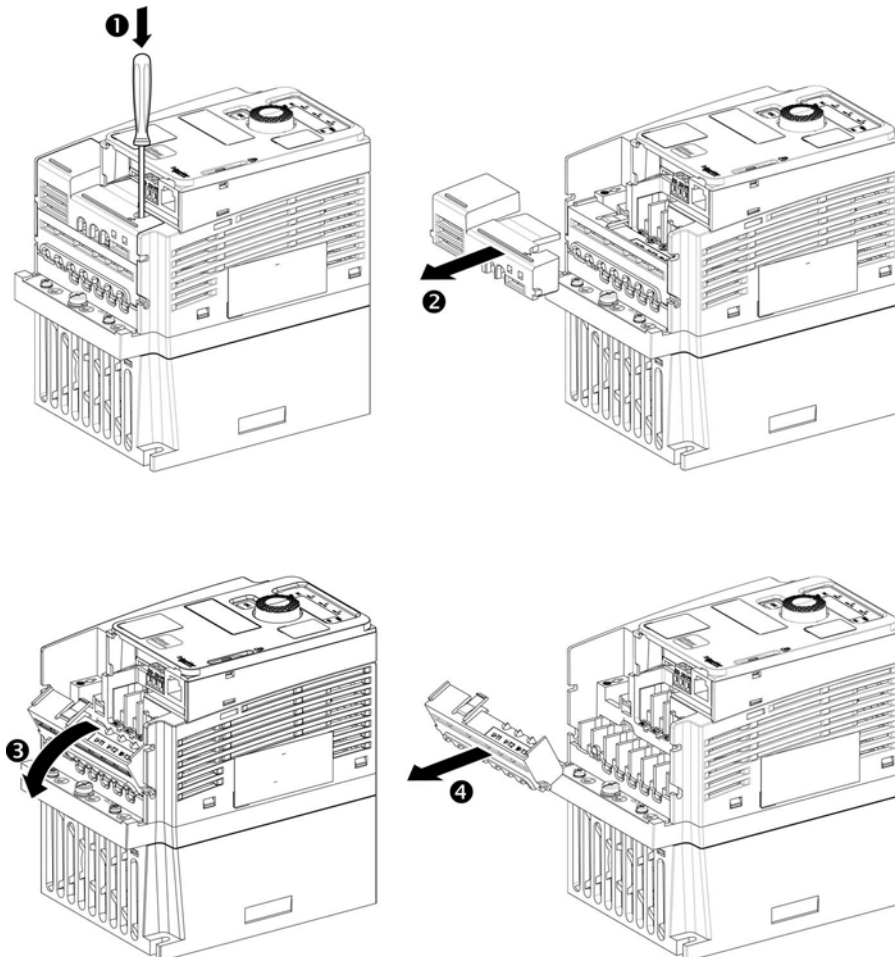

Apply the following instructions to access the power terminals on **frame sizes 2C** drives

Step	Action
1	Push the locking tab using a screwdriver.
2	Remove the wiring cover.
3	Incline the terminal cover
4	Remove the terminal cover

## Power Terminals Arrangement For Frame Size 2C

Single-phase

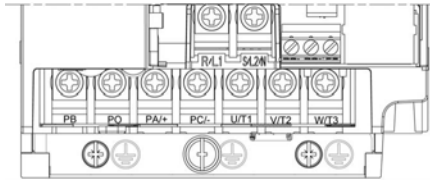

3-phase

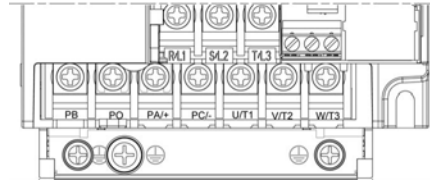

## Access To The Terminals For Frame Size 3C

### DANGER

#### HAZARD OF ELECTRIC SHOCK, EXPLOSION OR ARC FLASH

Read and understand the instructions in **Safety Information** chapter before performing any procedure in this chapter.

**Failure to follow these instructions will result in death or serious injury.**

### DANGER

#### HAZARD OF ELECTRIC SHOCK, EXPLOSION, OR ARC FLASH

After wiring the power terminals, refit properly the terminal cover and the wiring cover to meet the required degree of protection.

**Failure to follow these instructions will result in death or serious injury.**

Power supply terminals, motor terminals and braking resistor terminals are located on the bottom of the drive.

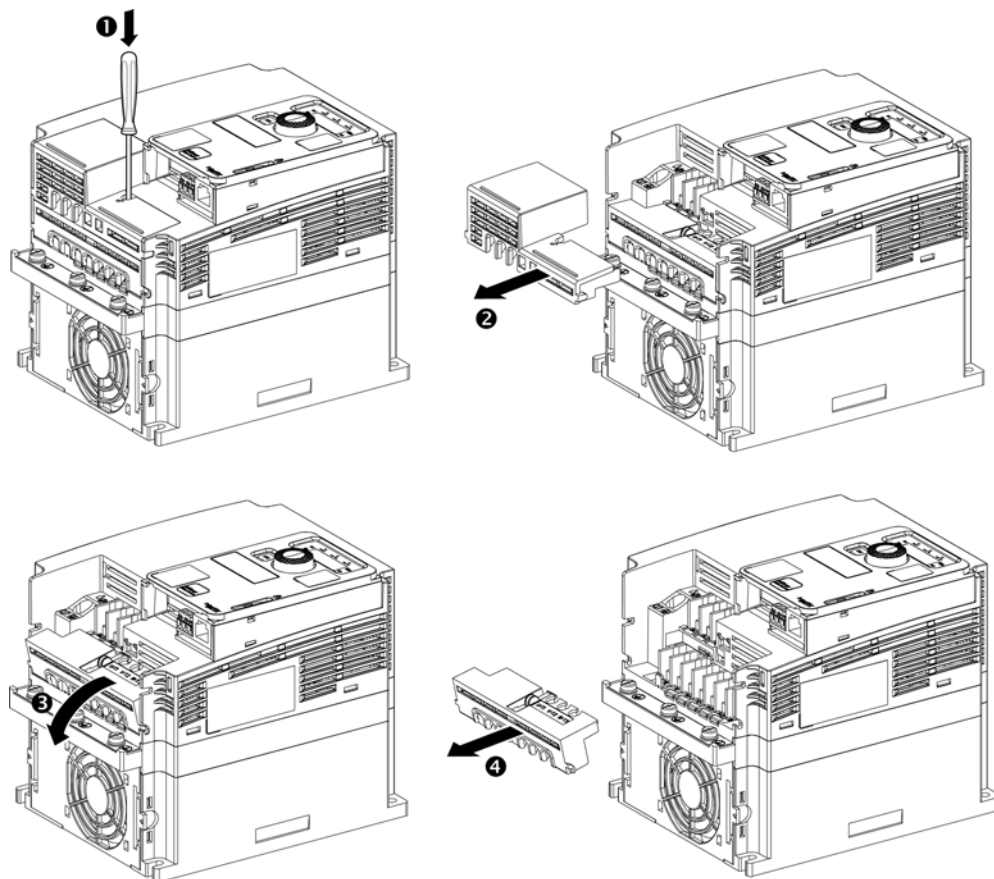

Apply the following instructions to access the power terminals on **frame sizes 3C** drives

Step	Action
1	Push the locking tab using a screwdriver.
2	Remove the wiring cover.
3	Incline the terminal cover
4	Remove the terminal cover

Power Terminals Arrangement For Frame Size 3C

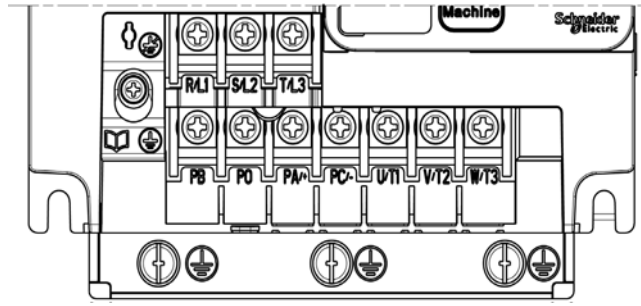

## Access To The Terminals For Frame Size 4C

### **⚡ ⚠ DANGER**

#### HAZARD OF ELECTRIC SHOCK, EXPLOSION OR ARC FLASH

Read and understand the instructions in **Safety Information** chapter before performing any procedure in this chapter.

**Failure to follow these instructions will result in death or serious injury.**

### **⚡ ⚠ DANGER**

#### HAZARD OF ELECTRIC SHOCK, EXPLOSION, OR ARC FLASH

After wiring the power terminals, refit properly the terminal cover and the wiring cover to meet the required degree of protection.

**Failure to follow these instructions will result in death or serious injury.**

Power supply terminals, motor terminals and braking resistor terminals are located on the bottom of the drive.

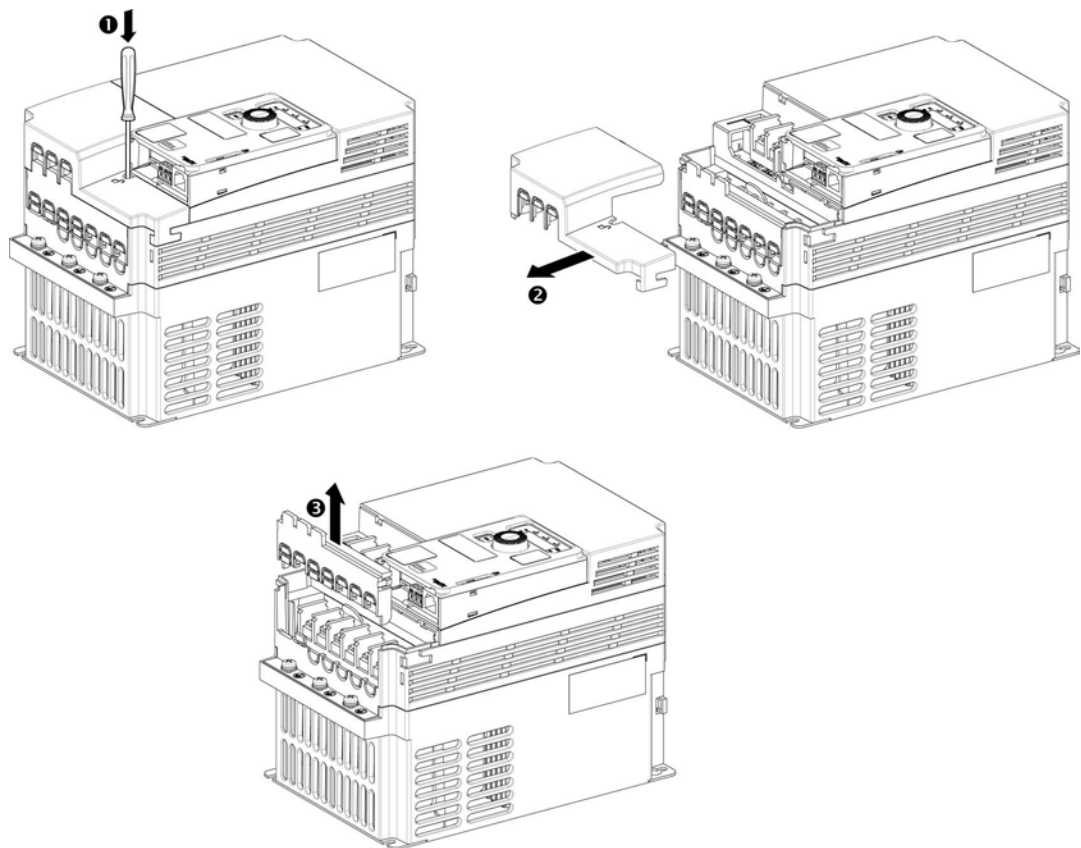

Apply the following instructions to access the power terminals on **frame sizes 4C** drives

Step	Action
1	Push the locking tab using a screwdriver.
2	Remove the wiring cover.
3	Incline the terminal cover
4	Remove the terminal cover

## Power Terminals Arrangement For Frame Size 4C

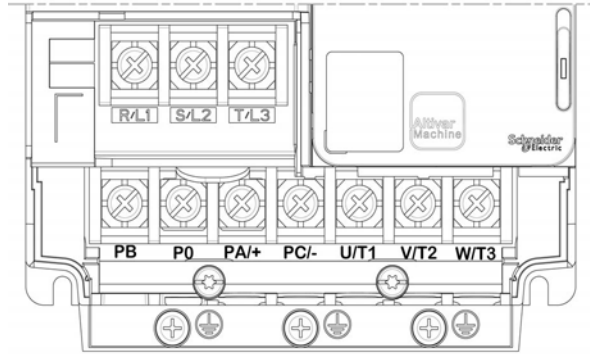

## Access To The Terminals For Frame Size 5C

### DANGER

#### HAZARD OF ELECTRIC SHOCK, EXPLOSION OR ARC FLASH

Read and understand the instructions in **Safety Information** chapter before performing any procedure in this chapter.

**Failure to follow these instructions will result in death or serious injury.**

### DANGER

#### HAZARD OF ELECTRIC SHOCK, EXPLOSION, OR ARC FLASH

After wiring the power terminals, refit properly the terminal cover and the wiring cover to meet the required degree of protection.

**Failure to follow these instructions will result in death or serious injury.**

Power supply terminals, motor terminals and braking resistor terminals are located on the bottom of the drive.

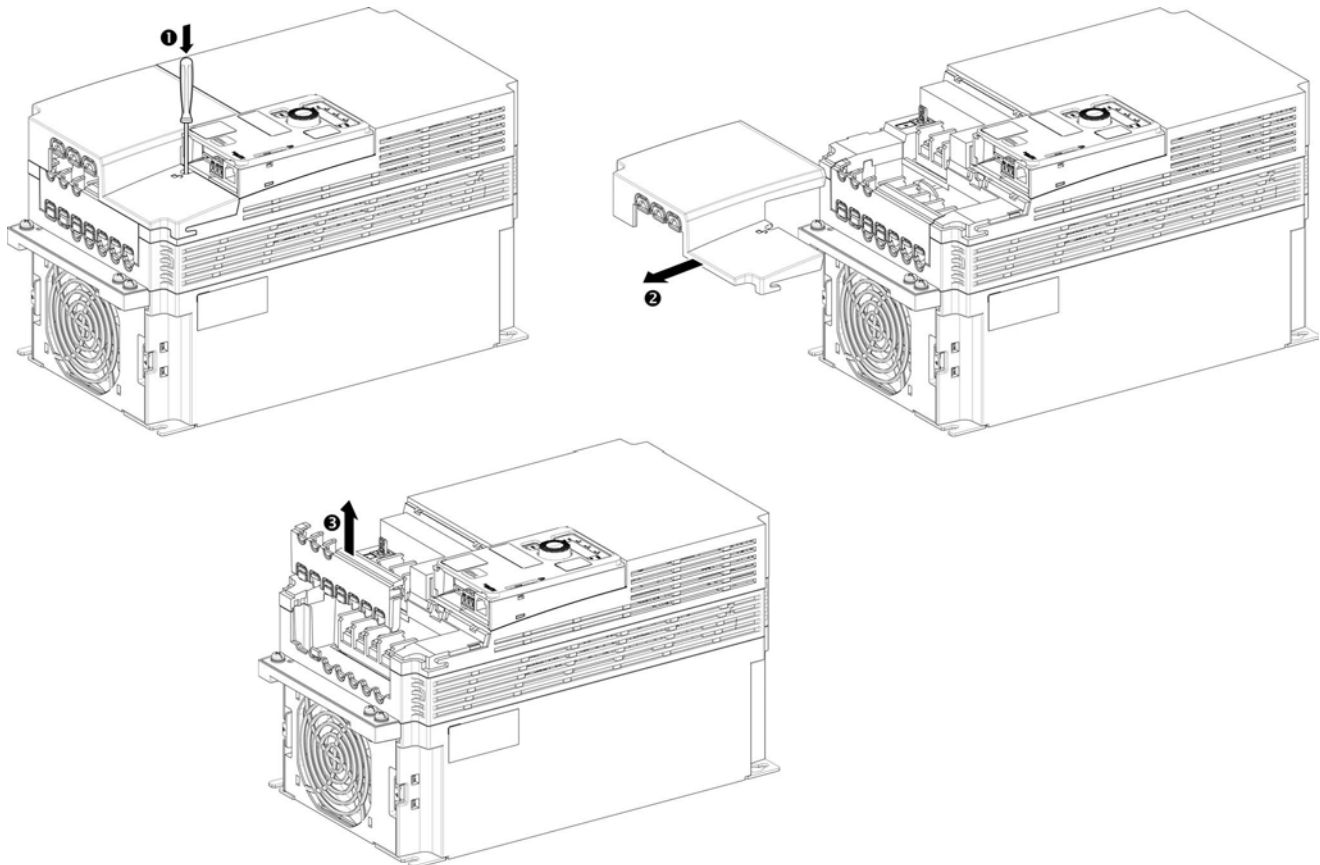

Apply the following instructions to access the power terminals on **frame sizes 5C** drives

Step	Action
1	Push the locking tab using a screwdriver.
2	Remove the wiring cover.
3	Incline the terminal cover
4	Remove the terminal cover



---

Power Terminals Arrangement For Frame Size 5C

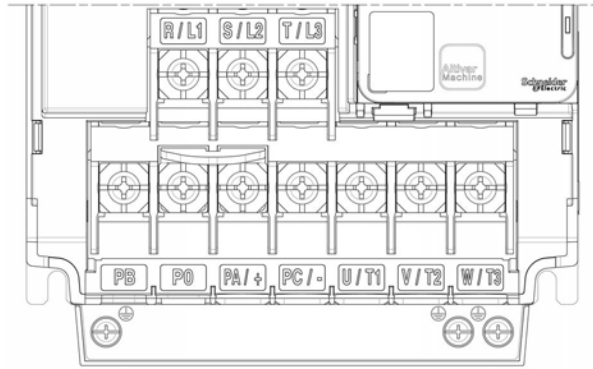

## EMC plate assembly fitting

### Output Connector and EMC Plate Assembly Fitting on Frame Sizes 1B, 2B

The EMC plate and the plug-in output power and braking unit terminal are fitted inseparably together. Input terminals are located on the top of the drive.

**NOTE:** Wiring can be carried out with the connector mounted on the drive or not.

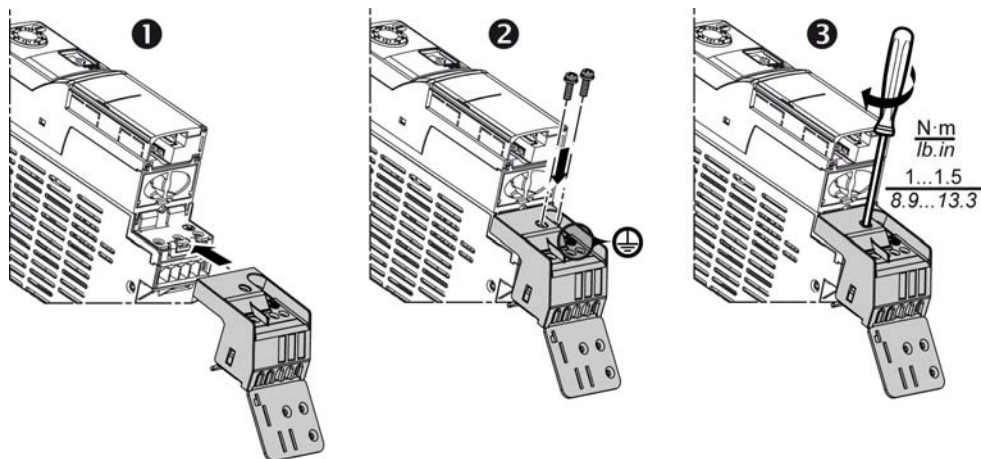

Perform the following instructions to install the plug-in connector

Step	Action
1	Plug the output power terminal.
2	Insert the mounting and the grounding screws (print: plus minus HS type 2).
3	Connect the brake (if any)
4	Connect the motor and ground cables

### EMC Plate Assembly Fitting on Frame Size 1C

Attach the EMC plate using 2 x M5 HS screws (1)

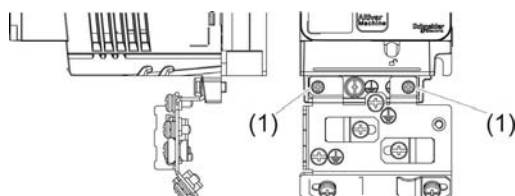

### EMC Plate Assembly Fitting on Frame Size 2

Attach the EMC plate using 2 x M5 HS screws (1)

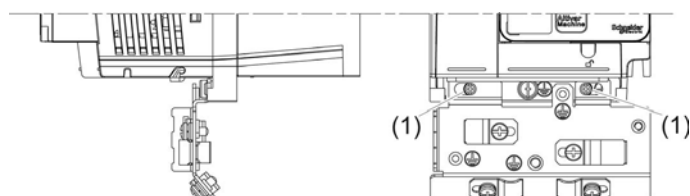

### EMC Plate Assembly Fitting on Frame Size 3

Attach the EMC plate using 2 x M5 HS screws (1)

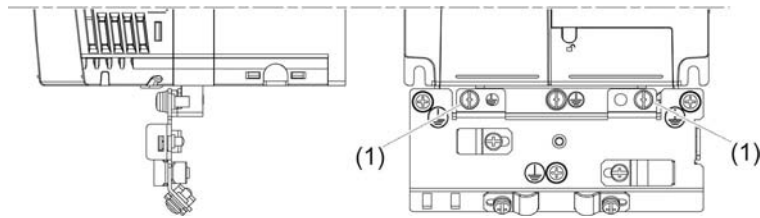

### EMC Plate Assembly Fitting on Frame Size 4B and 4C

Attach the EMC plate using 3 x M5 HS screws (1)

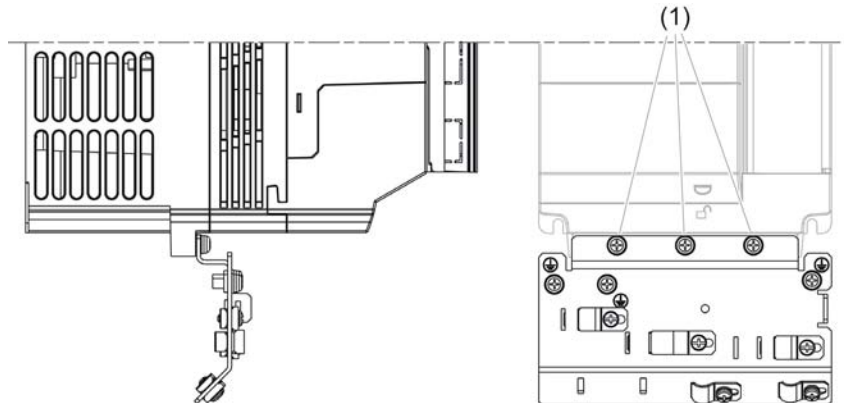

### EMC Plate Assembly Fitting on Frame Size 5B and 5C

Attach the EMC plate using 2 x M5 HS screws (1)

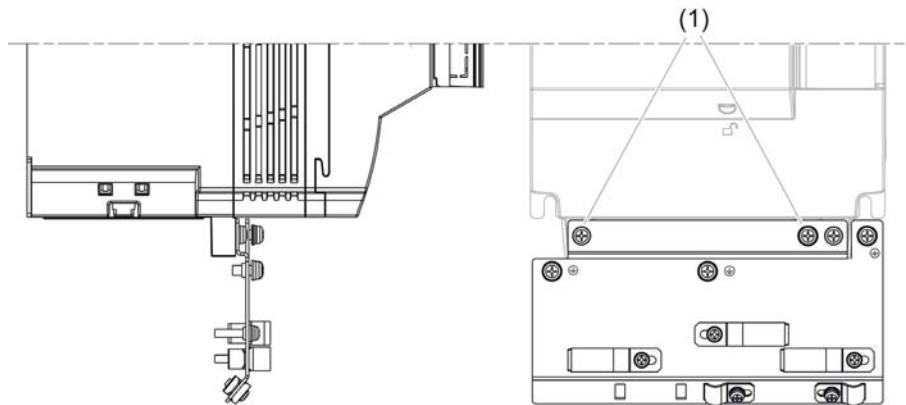

## EMC Plates Cable Routing

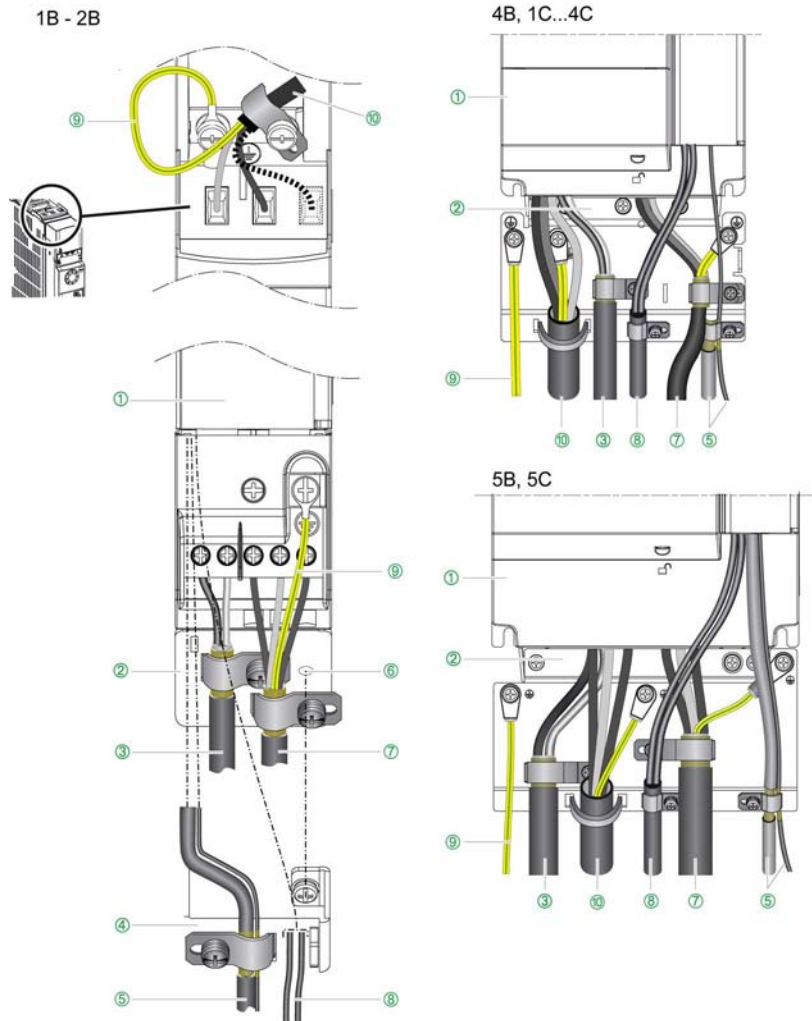

- ① Altivar 320. ② Sheet steel grounded EMC plate. ③ Shielded cable for braking resistor connection (if used). The shielding must be continuous and intermediate terminals must be installed on EMC plate. ④ Control EMC plate. ⑤ Shielded cable for control-signal section and STO safety function input connection. ⑥ Installation holes for the control EMC plate. ⑦ Shielded cable for motor connection, with shielding connected to ground at both ends. The shielding must be continuous and intermediate terminals must be installed on EMC plate. ⑧ Non-shielded wires for relay contact output. ⑨ Protective ground connection. ⑩ Non-shielded cable or wires for drive power supply.

## Electromagnetic Compatibility

Signal interference can cause unexpected responses of the drive and of other equipment in the vicinity of the drive.

 <b>WARNING</b>
<p><b>SIGNAL AND EQUIPMENT INTERFERENCE</b></p> <ul style="list-style-type: none"> <li>• Install the wiring in accordance with the EMC requirements described in this document.</li> <li>• Verify compliance with the EMC requirements described in this document.</li> <li>• Verify compliance with all EMC regulations and requirements applicable in the country in which the product is to be operated and with all EMC regulations and requirements applicable at the installation site.</li> </ul> <p><b>Failure to follow these instructions can result in death, serious injury, or equipment damage.</b></p>

### Limit Values

This product (\*) meets the EMC requirements according to the standard IEC 61800-3 if the measures described in this manual are implemented during installation. If the selected composition (product itself, mains filter, other accessories and measures) does not meet the requirements of category C1, the following information applies as it appears in IEC 61800-3:

(\*): Except ATV320•••M3C drives (for 3-phase 200...240 Vac supply mains) and ATV320•••S6C drives (for 3-phase 525...600 Vac supply mains). These drives do not include an EMC filter.

 <b>WARNING</b>
<p><b>RADIO INTERFERENCE</b></p> <p>In a domestic environment this product may cause radio interference in which case supplementary mitigation measures may be required.</p> <p><b>Failure to follow these instructions can result in death, serious injury, or equipment damage.</b></p>

### EMC requirements for the control cabinet

EMC measures	Objective
Use mounting plates with good electrical conductivity, connect large surface areas of metal parts, remove paint from contact areas.	Good conductivity due to large surface contact.
Ground the control cabinet, the control cabinet door and the mounting plate with ground straps or ground wires. The conductor cross section must be at least 10 mm <sup>2</sup> (AWG 8).	Reduces emissions.
Fit switching devices such as power contactors, relays or solenoid valves with interference suppression units or arc suppressors (for example, diodes, varistors, RC circuits).	Reduces mutual interference.
Install power components and control components separately.	

### Shielded cables

EMC measures	Objective
Connect large surface areas of cable shields, use cable clamps and ground straps.	Reduces emissions.
Use cable clamps to connect a large surface area of the shields of all shielded cables to the mounting plate at the control cabinet entry.	
Ground shields of digital signal wires ( <i>see page 54</i> ) at both ends by connecting them to a large surface area or via conductive connector housings	Reduces interference affecting the signal wires, reduces emissions
Ground the shields of analog signal wires directly at the device (signal input); insulate the shield at the other cable end or ground it via a capacitor (for example, 10 nF, 100 V or higher).	Reduces ground loops due to low-frequency interference.
Use only shielded motor cables with copper braid and a coverage of at least 85%, ground a large surface area of the shield at both ends.	Diverts interference currents in a controlled way, reduces emissions.

## Cable Installation

EMC measures	Objective
Do not route fieldbus cables and signal wires in a single cable duct together with lines with DC and AC voltages of more than 60 V. (Fieldbus cables, signal lines and analog lines may be in the same cable duct) Recommendation: Use separate cable ducts at least 20 cm apart.	Reduces mutual interference.
Keep cables as short as possible. Do not install unnecessary cable loops, use short cables from the central grounding point in the control cabinet to the external ground connection.	Reduces capacitive and inductive interference.
Use equipotential bonding conductors in the following cases: wide-area installations, different voltage supplies and installation across several buildings.	Reduces current in the cable shield, reduces emissions.
Use fine stranded equipotential bonding conductors.	Diverts high-frequency interference currents
If motor and machine are not conductively connected, for example by an insulated flange or a connection without surface contact, you must ground the motor with a ground strap or a ground wire. The conductor cross section must be at least 10 mm <sup>2</sup> (AWG 6).	Reduces emissions, increases immunity.
Use twisted pair for the DC supply. For digital and analog inputs use shielded twisted cables with a pitch of between 25...50 mm (1...2 in).	Reduces interference affecting the signal cables, reduces emissions.

## Power Supply

EMC measures	Objective
Operate product on mains with grounded neutral point.	Enables effectiveness of mains filter.
Surge arrester if there is a risk of overvoltage.	Reduces the risk of damage caused by overvoltage.

## Additional measures for EMC improvement

Depending on the application, the following measures can improve the EMC-dependent values:

EMC measures	Objective
Use mains reactors	Reduces mains harmonics, prolongs product service life.
Use external mains filters	Improves the EMC limit values.
Additional EMC measures, for example mounting in a closed control cabinet with 15 dB shielding attenuation of radiated interference	

**NOTE:** If using an additional input filter, it should be mounted as close as possible to the drive and connected directly to the supply mains via an unshielded cable.

## Control Terminals Electrical Data

### Characteristics of Terminals

**NOTE:**

- For a description of the terminal arrangement, refer to Arrangement and Characteristics of Control Terminals and Communication And I/O Ports (*see page 89*)
- For factory setting I/O assignment, refer to the Programming Manual.

Terminal	Description	I/O Type	Electrical characteristics
R1A	NO contact of relay R1	O	<b>Output Relay 1</b> <ul style="list-style-type: none"> <li>• Minimum switching capacity: 5 mA for 24 Vdc</li> <li>• Maximum switching current on resistive load: (cos <math>\phi</math> = 1): 3 A for 250 Vac (OVC II) and 4 A for 30 Vdc</li> <li>• Maximum switching current on inductive load: (cos <math>\phi</math> = 0.4 and L/R = 7 ms): 2 A for 250 Vac (OVC II) and 30 Vdc</li> <li>• Refresh time: 2 ms</li> <li>• Service life: 100,000 operations at maximum switching current</li> </ul>
R1B	NC contact of relay R1	O	
R1C	Common point contact of relay R1	O	
COM	Analog I/O common	I/O	0 V
AQ1	Analog output	O	AQ: Analog output software-configurable for voltage or current <ul style="list-style-type: none"> <li>• Voltage analog output 0...10 Vdc. Minimum load impedance 470 <math>\Omega</math>,</li> <li>• Current analog output X-Y mA by programming X and Y from 0...20 mA, maximum load impedance 800 <math>\Omega</math></li> <li>• Sampling time: 2 ms</li> <li>• Resolution 10 bits</li> <li>• Accuracy:               <ul style="list-style-type: none"> <li>○ <math>\pm 1\%</math> at 25 °C <math>\pm 10</math> °C (77 °F)</li> <li>○ <math>\pm 2\%</math> for a temperature variation of 60 °C (108 °F)</li> </ul> </li> <li>• Linearity <math>\pm 0.3\%</math></li> </ul>
COM	Analog I/O common	I/O	0 V
AI3	Current analog input	I	Analog input 0-20 mA (or 4-20 mA, X-20 mA, 20-Y mA). X and Y can be programmed from 0 to 20 mA <ul style="list-style-type: none"> <li>• Impedance: 250 <math>\Omega</math></li> <li>• Resolution: 10 bits</li> <li>• Accuracy:               <ul style="list-style-type: none"> <li>○ <math>\pm 0.5\%</math> at 25 °C (77 °F)</li> <li>○ <math>\pm 0.7\%</math> for a temperature variation of 60 °C (108 °F)</li> </ul> </li> <li>• Linearity <math>\pm 0.2\%</math> (maximum <math>\pm 0.5\%</math>) of full scale</li> <li>• Sampling time: 2 ms</li> </ul>
AI2	Voltage analog input	I	Bipolar analog input 0 $\pm$ 10 Vdc (maximum voltage $\pm 30$ Vdc) <p><b>The + or – polarity of the voltage on AI2 affects the direction of the setpoint and therefore the direction of operation.</b></p> <ul style="list-style-type: none"> <li>• Impedance: 30 k<math>\Omega</math></li> <li>• Resolution: 10 bits</li> <li>• Accuracy:               <ul style="list-style-type: none"> <li>○ <math>\pm 0.5\%</math> at 25 °C (77 °F)</li> <li>○ <math>\pm 0.7\%</math> for a temperature variation of 60 °C (108 °F)</li> </ul> </li> <li>• Linearity <math>\pm 0.2\%</math> (maximum <math>\pm 0.5\%</math>) of full scale</li> <li>• Sampling time: 2 ms</li> </ul>
10V	Power supply for reference potentiometer	O	Internal supply for the analog inputs <ul style="list-style-type: none"> <li>• + 10 Vdc</li> <li>• Tolerance: 0...10%</li> <li>• Current: maximum 10 mA</li> </ul>
AI1	Voltage analog input	I	Analog input 0 + 10 Vdc <ul style="list-style-type: none"> <li>• Impedance: 30 k<math>\Omega</math></li> <li>• Resolution: 10 bit converter</li> <li>• Accuracy:               <ul style="list-style-type: none"> <li>○ <math>\pm 0.5\%</math> at 25 °C (77 °F)</li> <li>○ <math>\pm 0.7\%</math> for a temperature variation of 60 °C (108 °F)</li> </ul> </li> <li>• Linearity <math>\pm 0.2\%</math> (maximum <math>\pm 0.5\%</math>) of full scale</li> <li>• Sampling time: 2 ms</li> </ul>

Terminal	Description	I/O Type	Electrical characteristics
COM	Analog I/O common	I/O	0 V
+24	Digital input power supply	I	<ul style="list-style-type: none"> <li>• +24 Vdc input supply</li> <li>• Tolerance: -15...+20%</li> <li>• Current: 100 mA</li> </ul>
R2A R2C	NO contact of programmable relay R2	O	<b>Output Relay 2</b> <ul style="list-style-type: none"> <li>• Minimum switching capacity: 5 mA for 24 Vdc</li> <li>• Maximum switching current on resistive load: (cos <math>\phi</math> = 1): 5 A for 250 Vac (OVC II) and 30 Vdc</li> <li>• Maximum switching current on inductive load: (cos <math>\phi</math> = 0.4 and L/R = 7 ms): 2 A for 250 Vac (OVC II) and 30 Vdc</li> <li>• Refresh time: 2 ms</li> <li>• Service life: <ul style="list-style-type: none"> <li>○ 100,000 operations at maximum switching power</li> <li>○ 1,000,000 operations with 500 mA current to inductive load 58 Vac or 30 Vdc</li> </ul> </li> </ul>
STO	STO (Safe Torque Off) input	I	<ul style="list-style-type: none"> <li>• Input: +24 Vdc</li> <li>• Impedance: 1.5 k<math>\Omega</math></li> <li>• Refer to the Wiring Diagrams section (<a href="#">see page 54</a>) and the ATV320 Safety Functions Manual (<a href="#">NVE50467</a>) available on <a href="http://www.schneider-electric.com">www.schneider-electric.com</a></li> </ul>
P24	Output power supply for digital inputs and STO	O	<ul style="list-style-type: none"> <li>• +24 Vdc</li> <li>• Tolerance: -15...+20%</li> <li>• Current: maximum 1.1 A</li> </ul>
DQ+ DQ-	Digital output	O	Open collector output configurable as sink or source using SW1 switch <ul style="list-style-type: none"> <li>• Refresh time: 2 ms</li> <li>• Maximum voltage: 30 Vdc</li> <li>• Maximum current: 100 mA</li> </ul>
DI6 DI5	Digital inputs	I	If programmed as digital inputs, same characteristics as DI1 to DI4 <ul style="list-style-type: none"> <li>• DI5 can be programmed as pulse input 20 kpps (pulse per second).</li> <li>• DI6 can be used as PTC (Positive Temperature Coefficient) using SW2 switch (<a href="#">see page 89</a>).</li> <li>• Trip threshold: 3 k<math>\Omega</math>, reset threshold: 1.8 k<math>\Omega</math></li> <li>• Short-circuit detection threshold &lt; 50 <math>\Omega</math></li> </ul>
DI4 DI3 DI2 DI1	Digital inputs	I	4 programmable digital inputs configurable as sink or source using SW1 switch ( <a href="#">see page 89</a> ) <ul style="list-style-type: none"> <li>• + 24 Vdc power supply (maximum 30 Vdc)</li> <li>• State 0 if &lt; 5 Vdc, state 1 if &gt; 11 Vdc (in source mode)</li> <li>• State 0 if &gt; 16 Vdc, state 1 if &lt; 10 Vdc (in sink mode)</li> <li>• Response time 8 ms at Stop</li> </ul>
PE	Protective earth	-	ATV320••••C protective earth for fast communication. Wiring is detailed in the Control Block Wiring section ( <a href="#">see page 91</a> )



## Arrangement and Characteristics of Control Block Terminals and Communication and I/O Ports

### Wiring Characteristics

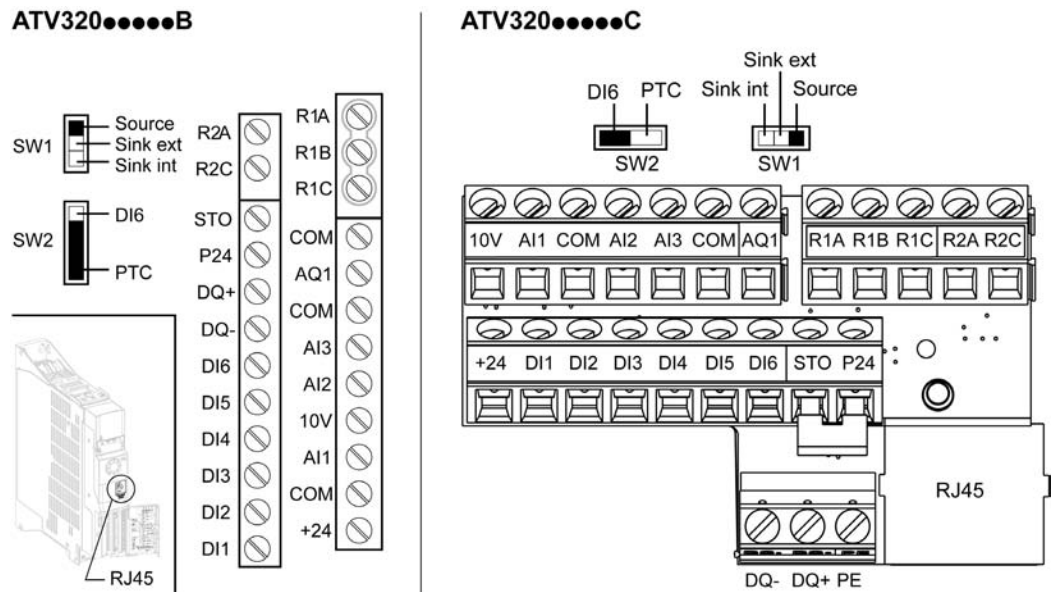

Wire cross sections and tightening torques

Control Terminals	Relay Output Wire Cross Section		Other Wire Cross Section		Tightening Torque
	Minimum (1)	Maximum	Minimum (1)	Maximum	
	mm <sup>2</sup> (AWG)	mm <sup>2</sup> (AWG)	mm <sup>2</sup> (AWG)	mm <sup>2</sup> (AWG)	
All terminals	0.75 (18)	1.5 (16)	0.5 (20)	1.5 (16)	0.5 (4.4)

(1) The value corresponds to the minimum permissible cross section of the terminal.

**NOTE:** Control Terminal Electrical data. ([see page 87](#))

### RJ45 Communication port

It is used to connect a:

- PC using SoMove software
- Remote graphic display terminal, using a Modbus serial line
- Modbus or CANopen network
- Configuration loader tool...

**NOTE:** Check that RJ45 cable is not damaged prior to connect it to the product otherwise the power supply of the control could be lost.

## Wiring The Control Part

### PELV Requirements of connected devices

#### DANGER

##### HAZARD OF ELECTRIC SHOCK, EXPLOSION OR ARC FLASH

- Verify that the temperature sensors in the motor meet the PELV requirements.
- Verify that the motor encoder meets the PELV requirements.
- Verify that any other equipment connected via signal cables meets the PELV requirements.

**Failure to follow these instructions will result in death or serious injury.**

#### WARNING

##### UNEXPECTED EQUIPMENT OPERATION

- Use shielded cables for all digital and analog I/O and communication signals.
- Ground cable shields at a single point.
- Route communication and I/O cables separately from power cables.

**Failure to follow these instructions can result in death, serious injury, or equipment damage.**

- Keep the control circuits away from the power cables. For digital and analog inputs/outputs, use shielded twisted cables with a pitch of 25...50 mm (1 in. and 2 in.)
- It is recommended to use cable ends, available on [www.schneider-electric.com](http://www.schneider-electric.com).

### Access to the Terminals

#### DANGER

##### HAZARD OF ELECTRIC SHOCK, EXPLOSION OR ARC FLASH

Read and understand the instructions in **Safety Information** chapter before performing any procedure in this chapter.

**Failure to follow these instructions will result in death or serious injury.**

Open the cover as shown in the examples below to access the terminals. All screws are M3 slotted type, 3.8 mm (0.15 in.) diameter.

ATV320●●●●●B

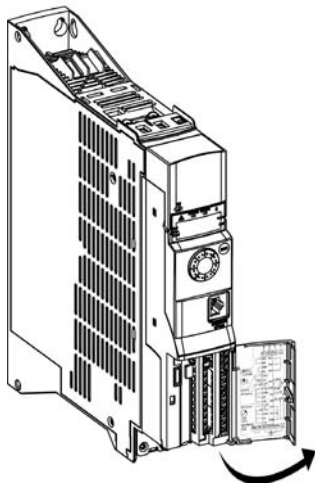

ATV320●●●●●C

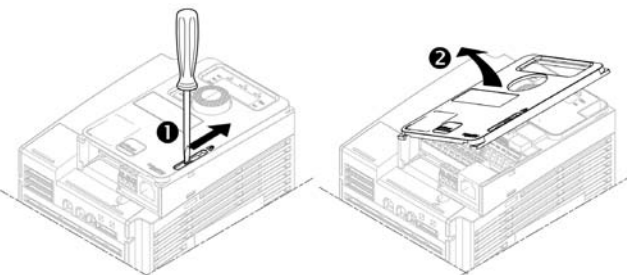

ATV320•••••C control block can be removed to facilitate the wiring.

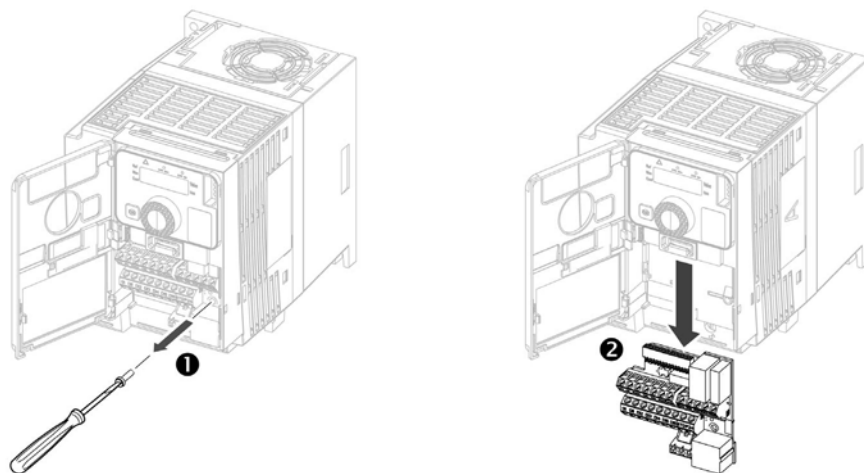

### Control Block Wiring

Apply the following instructions to wire the control block terminals

Step	Action
1	Wire the P24, the STO, the digital inputs (DI1...DI6), the +24, DQ-, DQ+ and PE terminals
2	Wire the 10V, the analog inputs (AI1...AI3), the COM, The digital input AQ1 and the COM terminals
3	Wire the Relay outputs
4	On ATV320•••••C, wire the PE terminal as shown below - example of frame size 3C



# Chapter 5

## Checking Installation

### Before Switching On

The safety function STO (Safe Torque Off) does not remove power from the DC bus. The safety function STO only removes power to the motor. The DC bus voltage and the mains voltage to the drive are still present.

 <b>DANGER</b>
<b>HAZARD OF ELECTRIC SHOCK</b> <ul style="list-style-type: none"><li>• Do not use the safety function STO for any other purposes than its intended function.</li><li>• Use an appropriate switch, that is not part of the circuit of the safety function STO, to disconnect the drive from the mains power.</li></ul> <b>Failure to follow these instructions will result in death or serious injury.</b>

Unsuitable settings or unsuitable data or unsuitable wiring may trigger unintended movements, trigger signals, damage parts and disable monitoring functions.

 <b>WARNING</b>
<b>UNANTICIPATED EQUIPMENT OPERATION</b> <ul style="list-style-type: none"><li>• Only start the system if there are no persons or obstructions in the zone of operation.</li><li>• Verify that a functioning emergency stop push-button is within reach of all persons involved in the operation.</li><li>• Do not operate the drive system with unknown settings or data.</li><li>• Verify that the wiring is appropriate for the settings.</li><li>• Never modify a parameter unless you fully understand the parameter and all effects of the modification.</li><li>• When commissioning, carefully run tests for all operating states, operating conditions and potential error situations.</li><li>• Anticipate movements in unintended directions or oscillation of the motor.</li></ul> <b>Failure to follow these instructions can result in death, serious injury, or equipment damage.</b>

If the power stage is disabled unintentionally, for example as a result of power outage, errors or functions, there is a possibility that the motor is no longer decelerated in a controlled way.

 <b>WARNING</b>
<b>UNANTICIPATED EQUIPMENT OPERATION</b> <p>Verify that movements without braking effect cannot cause injuries or equipment damage.</p> <b>Failure to follow these instructions can result in death, serious injury, or equipment damage.</b>

### Mechanical Installation

Verify the mechanical installation of the entire drive system:

Step	Action	<input checked="" type="checkbox"/>
1	Does the installation meet the specified distance requirements?	<input type="checkbox"/>
2	Did you tighten all fastening screws with the specified tightening torque?	<input type="checkbox"/>

---

## Electrical installation

Verify the electrical connections and the cabling:

Step	Action	✓
1	Did you connect all protective ground conductors?	
2	Do all fuses and circuit breaker have the correct rating; are the fuses of the specified type? (refer to the information provided in the ATV320 Getting Started Annex (SCCR) reference: <a href="#">NVE21777</a> ).	
3	Did you connect or insulate all wires at the cable ends?	
4	Did you properly connect and install all cables and connectors?	
5	Did you properly connect the signal wires?	
6	Are the required shield connections EMC-compliant?	
7	Did you take all measures for EMC compliance?	

## Covers And Seals

Verify that all devices, doors and covers of cabinet are properly installed to meet the required degree of protection.

# Chapter 6

## Maintenance

### Scheduled servicing

#### Servicing

** DANGER**

**HAZARD OF ELECTRIC SHOCK, EXPLOSION OR ARC FLASH**

Read and understand the instructions in **Safety Information** chapter before performing any procedure in this chapter.

**Failure to follow these instructions will result in death or serious injury.**

The temperature of the products described in this manual may exceed 80 °C (176 °F) during operation.

** WARNING**

**HOT SURFACES**

- Ensure that any contact with hot surfaces is avoided.
- Do not allow flammable or heat-sensitive parts in the immediate vicinity of hot surfaces.
- Verify that the product has sufficiently cooled down before handling it.
- Verify that the heat dissipation is sufficient by performing a test run under maximum load conditions.

**Failure to follow these instructions can result in death, serious injury, or equipment damage.**

***NOTICE***

**RISK OF DAMAGE TO THE DRIVE**

Perform the following activities.

**Failure to follow these instructions can result in equipment damage.**

Environment	Part concerned	Action	Periodicity (1)
Knock on the product	Housing - control block (led - display, if any)	Verify the drive visual aspect	At least each year
Corrosion	Terminals - connector - screws - EMC plate	Inspect and clean if required	
Dust	Terminals - fans - blowholes - enclosures air inlets and outlets - cabinets air filters	Inspect and clean if required	
Temperature	Around the product	Verify and correct if required	
Cooling	Fan	Verify the fan operation	At least each year
		Replace the fan, see catalog and the instructions sheets on <a href="http://www.schneider-electric.com">www.schneider-electric.com</a> .	After 3 to 5 years, depending on the operating conditions
Vibration		Verify tightening torques	At least each year

**(1)** As from the date of commissioning. The maintenance intervals really necessary depend on the ambient conditions.

Fans may continue to run for a certain period of time even after power to the product has been disconnected.

## CAUTION

### **RUNNING FANS**

Verify that fans have come to a complete standstill before handling them.

**Failure to follow these instructions can result in injury or equipment damage.**

### Diagnostic And Troubleshooting

Refer to the Programming Manual available on [www.schneider-electric.com](http://www.schneider-electric.com).

### Spares and repairs

Serviceable product. Please refer to your Customer Care Center.

**Fan replacement:** It is possible to order a new fan for the ATV320 maintenance, see the commercial references on [www.schneider-electric.com](http://www.schneider-electric.com).

### Long time storage

If the drive was not connected to mains for an extended period of time, the capacitors must be restored to their full performance before the motor is started.

## **NOTICE**

### **REDUCED CAPACITOR PERFORMANCE**

- Apply mains voltage to the drive for one hour before starting the motor if the drive has not been connected to mains for the following periods of time:
  - 12 months at a maximum storage temperature of +50°C (+122°F)
  - 24 months at a maximum storage temperature of +45°C (+113°F)
  - 36 months at a maximum storage temperature of +40°C (+104°F)
- Verify that no Run command can be applied before the period of one hour has elapsed.
- Verify the date of manufacture if the drive is commissioned for the first time and run the specified procedure if the date of manufacture is more than 12 months in the past.

**Failure to follow these instructions can result in equipment damage.**

If the specified procedure cannot be performed without a Run command because of internal mains contactor control, perform this procedure with the power stage enabled, but the motor being at standstill so that there is no appreciable mains current in the capacitors.





## E

### Error

Discrepancy between a detected (computed, measured, or signaled) value or condition and the specified or theoretically correct value or condition.

## F

### Factory setting

Factory settings when the product is shipped

### Fault

Fault is an operating state. If the monitoring functions detect an error, a transition to this operating state is triggered, depending on the error class. A "Fault reset" is required to exit this operating state after the cause of the detected error has been removed. Further information can be found in the pertinent standards such as IEC 61800-7, ODVA Common Industrial Protocol (CIP).

### Fault reset

A function used to restore the drive to an operational state after a detected error is cleared by removing the cause of the error so that the error is no longer active.

## L

### L/R

Time constant equal to the quotient of inductance value (L) over the resistance value (R).

## N

### NC contact

Normally Closed contact.

### NO contact

Normally Open contact.

## P

### PELV

Protective Extra Low Voltage, low voltage with isolation. For more information: IEC 60364-4-41

### PLC

Programmable logic controller

### Power stage

The power stage controls the motor. The power stage generates current for controlling the motor.

### PTC

Positive Temperature Coefficient. PTC thermistor probes integrated in the motor to measure its temperature

## R

### REACH

Registration, Evaluation, Authorisation and restriction of Chemicals regulation

### RoHS

Restriction of Hazardous Substances

## S

### STO

Safe Torque Off: No power that could cause torque or force is supplied to the motor

## W

### Warning

If the term is used outside the context of safety instructions, a warning alerts to a potential problem that was detected by a monitoring function. A warning does not cause a transition of the operating state.



