

**Pro-face**

by **Schneider** Electric

# SP5000X Series Hardware Manual

---

The information provided in this documentation contains general descriptions and/or technical characteristics of the performance of the products contained herein. This documentation is not intended as a substitute for and is not to be used for determining suitability or reliability of these products for specific user applications. It is the duty of any such user or integrator to perform the appropriate and complete risk analysis, evaluation and testing of the products with respect to the relevant specific application or use thereof. Neither Schneider Electric nor any of its affiliates or subsidiaries (hereinafter, referred to as Schneider Electric) shall be responsible or liable for misuse of the information that is contained herein. If you have any suggestions for improvements or amendments or have found errors in this publication, please notify us.

You agree not to reproduce, other than for your own personal, noncommercial use, all or part of this document on any medium whatsoever without permission of Schneider Electric, given in writing. You also agree not to establish any hypertext links to this document or its content. Schneider Electric does not grant any right or license for the personal and noncommercial use of the document or its content, except for a non-exclusive license to consult it on an "as is" basis, at your own risk. All other rights are reserved.

All pertinent state, regional, and local safety regulations must be observed when installing and using this product. For reasons of safety and to help ensure compliance with documented system data, only the manufacturer should perform repairs to components.

When devices are used for applications with technical safety requirements, the relevant instructions must be followed.

Failure to use Schneider Electric software or approved software with our hardware products may result in injury, harm, or improper operating results.

Failure to observe this information can result in injury or equipment damage.

Copyright © 2019 Schneider Electric Japan Holdings Ltd. All rights reserved.

# Table of Contents



	<b>Safety Information</b> .....	<b>5</b>
	<b>About the Book</b> .....	<b>7</b>
<b>Chapter 1</b>	<b>Overview</b> .....	<b>11</b>
	Model Numbers .....	<b>12</b>
	Package Contents .....	<b>13</b>
	Certifications and Standards .....	<b>15</b>
	Federal Communication Commission Radio Frequency Interference Statement - For USA .....	<b>17</b>
	Hazardous Location Installation - For USA and Canada .....	<b>18</b>
<b>Chapter 2</b>	<b>Device Connectivity</b> .....	<b>21</b>
	System Design .....	<b>22</b>
	Accessories .....	<b>24</b>
<b>Chapter 3</b>	<b>Parts Identification and Functions</b> .....	<b>27</b>
3.1	Parts Identification .....	<b>28</b>
	SP-5B90 .....	<b>29</b>
	SP-5490WA .....	<b>31</b>
	SP-5690WA/5790WA .....	<b>32</b>
3.2	LED Indications .....	<b>33</b>
	LED Indications .....	<b>33</b>
<b>Chapter 4</b>	<b>Specifications</b> .....	<b>35</b>
4.1	General Specifications .....	<b>36</b>
	Electrical Specifications .....	<b>37</b>
	Environmental Specifications .....	<b>38</b>
	Structural Specifications .....	<b>40</b>
4.2	Functional Specifications .....	<b>42</b>
	Display Specifications .....	<b>43</b>
	Touch Panel .....	<b>44</b>
	Memory, Clock .....	<b>45</b>
4.3	Interface Specifications .....	<b>46</b>
	Interface Specifications .....	<b>47</b>
	Interface Connection .....	<b>48</b>
	Serial Interface (RS-232C and RS-422/RS-485) for COM1/COM2 .....	<b>49</b>
	Auxiliary Output/Speaker Output Interface (AUX) .....	<b>52</b>
<b>Chapter 5</b>	<b>Dimensions</b> .....	<b>53</b>
	SP-5B90 .....	<b>54</b>
	SP-5490WA .....	<b>55</b>
	SP-5690WA .....	<b>58</b>
	SP-5790WA .....	<b>61</b>
<b>Chapter 6</b>	<b>Installation and Wiring</b> .....	<b>65</b>
6.1	Installation .....	<b>66</b>
	Introduction .....	<b>67</b>
	Installation Requirements .....	<b>68</b>
	Panel Cut Dimensions .....	<b>70</b>

---

Installing onto Display Module . . . . .	71
Attaching Fixing Bracket (SP-5490WA) . . . . .	73
Attaching Fixing Bracket (SP-5690WA/5790WA) . . . . .	74
Removing from Display Module . . . . .	75
Installing to the Panel . . . . .	77
Removing from the Panel . . . . .	80
6.2 Wiring Principles . . . . .	82
Connecting the DC Power Cord . . . . .	83
Connecting the Power Supply . . . . .	86
Grounding . . . . .	88
6.3 USB Cable Clamp . . . . .	89
USB Clamp Type A (1 port) . . . . .	90
USB Clamp mini-B (1 port) . . . . .	92
6.4 AUX Connector . . . . .	94
Introduction . . . . .	94
6.5 SD Card Insertion/Removal . . . . .	95
Introduction . . . . .	96
Inserting the SD Card . . . . .	97
Removing the SD Card . . . . .	98
6.6 Isolation Unit and USB/RS-422/485 Conversion Adapter . . . . .	99
Introduction . . . . .	100
Installing to the Box Module . . . . .	101
<b>Chapter 7 Maintenance . . . . .</b>	<b>103</b>
Regular Cleaning . . . . .	104
Periodic Check Points . . . . .	105
Replacing the Installation Gasket . . . . .	106
Replacing the Primary Battery . . . . .	107
Replacing the System Card (SD Card) . . . . .	110
Replacing the Backlight . . . . .	112
After-sales Service . . . . .	113

# Safety Information



## Important Information

### NOTICE

Read these instructions carefully, and look at the equipment to become familiar with the device before trying to install, operate, service, or maintain it. The following special messages may appear throughout this documentation or on the equipment to warn of potential hazards or to call attention to information that clarifies or simplifies a procedure.



The addition of this symbol to a “Danger” or “Warning” safety label indicates that an electrical hazard exists which will result in personal injury if the instructions are not followed.



This is the safety alert symbol. It is used to alert you to potential personal injury hazards. Obey all safety messages that follow this symbol to avoid possible injury or death.

## **DANGER**

**DANGER** indicates a hazardous situation which, if not avoided, **will result in** death or serious injury.

## **WARNING**

**WARNING** indicates a hazardous situation which, if not avoided, **could result in** death or serious injury.

## **CAUTION**

**CAUTION** indicates a hazardous situation which, if not avoided, **could result in** minor or moderate injury.

## **NOTICE**

**NOTICE** is used to address practices not related to physical injury.

### PLEASE NOTE

Electrical equipment should be installed, operated, serviced, and maintained only by qualified personnel. No responsibility is assumed by Schneider Electric for any consequences arising out of the use of this material.

A qualified person is one who has skills and knowledge related to the construction and operation of electrical equipment and its installation, and has received safety training to recognize and avoid the hazards involved.



---

# About the Book

---



## At a Glance

### Document Scope

This manual describes how to use this product.

### Validity Note

This documentation is valid for this product.

The technical characteristics of the device(s) described in this manual also appear online at <http://www.pro-face.com>.

The characteristics presented in the present document should be the same as those that appear online. In line with our policy of constant improvement we may revise content over time to improve clarity and accuracy. In the event that you see a difference between the document and online information, use the online information as your reference.

### Registered Trademarks

Microsoft and Windows are registered trademarks of Microsoft Corporation in the United States and/or other countries.

Product names used in this manual may be the registered trademarks owned by the respective proprietors.

### Related Documents

You can download the manuals related to this product, such as the software manual, from our support site at <http://www.pro-face.com/trans/en/manual/1001.html>.

### Product Related Information

If the equipment is used in a manner not specified by the manufacturer, the protection provided by the equipment may be impaired.

## DANGER

### HAZARD OF ELECTRIC SHOCK, EXPLOSION, OR ARC FLASH

- Remove all power from the device before removing any covers or elements of the system, and prior to installing or removing any accessories, hardware, or cables.
- Unplug the power cable from both this product and the power supply prior to installing or removing the product.
- Always use a properly rated voltage sensing device to confirm power is off where and when indicated.
- Replace and secure all covers or elements of the system before applying power to this product.
- Use only the specified voltage when operating this product. This product is designed to use 12 to 24 Vdc. Always check whether your device is DC powered before applying power.

**Failure to follow these instructions will result in death or serious injury.**

Critical alarm indicators and system functions require independent and redundant protection hardware and/or mechanical interlocks.

When you cycle power, wait at least 10 seconds after it has been turned off. If this product is restarted too quickly, it may not operate correctly.

In the event the screen cannot be properly read, for example, if the backlight is not functioning, it may be difficult or impossible to identify a function. Functions that may present a hazard if not immediately executed, such as a fuel shut-off, must be provided independently of this product. The machine's control system design must take into account the possibility of the backlight no longer functioning and the operator being unable to control the machine or making mistakes in the control of the machine.

## WARNING

### LOSS OF CONTROL

- The designer of any control scheme must consider the potential failure modes of control paths and, for certain critical control functions, provide a means to achieve a safe state during and after a path failure. Examples of critical control functions are emergency stop and overtravel stop, power outage and restart.
- Separate or redundant control paths must be provided for critical control functions.
- System control paths may include communication links. Consideration must be given to the implications of unanticipated transmission delays or failures of the link.
- Observe all accident prevention regulations and local safety guidelines.
- Each implementation of this product must be individually and thoroughly tested for proper operation before being placed into service.
- The machine control system design must take into account the possibility of the backlight no longer functioning and the operator being unable to control the machine, or making errors in the control of the machine.

**Failure to follow these instructions can result in death, serious injury, or equipment damage.**

For additional information, refer to NEMA ICS 1.1 (latest edition), "Safety Guidelines for the Application, Installation, and Maintenance of Solid State Control" and to NEMA ICS 7.1 (latest edition), "Safety Standards for Construction and Guide for Selection, Installation and Operation of Adjustable-Speed Drive Systems" or their equivalent governing your particular location.

## WARNING

### UNINTENDED EQUIPMENT OPERATION

- The application of this product requires expertise in the design and programming of control systems. Only persons with such expertise should be allowed to program, install, alter, and apply this product.
- Follow all local and national safety standards.

**Failure to follow these instructions can result in death, serious injury, or equipment damage.**

## WARNING

### UNINTENDED EQUIPMENT OPERATION

- Do not use this product as the only means of control for critical system functions such as motor start/stop or power control.
- Do not use this equipment as the only notification device for critical alarms, such as device overheating or overcurrent.
- Use only the software provided with this product. If you use another software, please confirm the operation and safety before use.

**Failure to follow these instructions can result in death, serious injury, or equipment damage.**



The following characteristics are specific to the LCD panel and are considered normal behavior:

- LCD screen may show unevenness in the brightness of certain images or may appear different when seen from outside the specified viewing angle. Extended shadows, or crosstalk may also appear on the sides of screen images.
- LCD screen pixels may contain black and white colored spots and color display may seem to have changed.
- When experiencing vibrations within a certain frequency range in a low temperature environment and vibration acceleration is above what is acceptable, the LCD screen may partially turn white. Once this condition ends, the issue is resolved.
- When the same image is displayed on the screen for a long period, an afterimage may appear when the image is changed.
- The panel brightness may decrease when used for a long time in an environment continuously filled with inert gas. To prevent deterioration of panel brightness, regularly ventilate the panel. For more information, please contact customer support.  
<http://www.pro-face.com/trans/en/manual/1015.htm/>

**NOTE:** Change the screen image periodically and try not to display the same image for a long period of time.

## **WARNING**

### **SERIOUS EYE AND SKIN INJURY**

The liquid in the LCD panel contains an irritant:

- Avoid direct skin contact with the liquid.
- Wear gloves when you handle a broken or leaking unit.
- Do not use sharp objects or tools in the vicinity of the LCD panel.
- Handle the LCD panel carefully to prevent puncture, bursting, or cracking of the panel material.
- If the panel is damaged and any liquid comes in contact with your skin, immediately rinse the area with running water for at least 15 minutes. If the liquid gets in your eyes, immediately rinse your eyes with running water for at least 15 minutes and consult a doctor.

**Failure to follow these instructions can result in death, serious injury, or equipment damage.**

**NOTE:** When there is water, oil, and so on, on the unit, exposing it to direct sunlight for long periods could cause discoloration of the display face. If the display face is wet, wipe off the moisture with a soft cloth.

## **CAUTION**

### **RISK OF BURNING INJURY**

- Do not touch the bezel or rear chassis during operation.
- Wear appropriate gloves for touch operation when operating in ambient temperatures less than 0 °C (32 °F) or greater than 60 °C (140 °F).

**Failure to follow these instructions can result in injury or equipment damage.**



---

# Chapter 1

## Overview

---

### What Is in This Chapter?

This chapter contains the following topics:

Topic	Page
Model Numbers	12
Package Contents	13
Certifications and Standards	15
Federal Communication Commission Radio Frequency Interference Statement - For USA	17
Hazardous Location Installation - For USA and Canada	18

## Model Numbers

### Model Number Configuration

The following describes the configuration of model numbers.

#### Box Module

Digit Position									
1	2	3	4	5	6	7	8	9	10
P	F	X	(model)		(series)	(-)	(class)		(other)
			SP		5	B: BOX	90: eXtreme		F0H: Harsh environment model

#### Display Module

Digit Position												
1	2	3	4	5	6	7	8	9	10	11	12	13
P	F	X	(model)		(series)	(size)	(type)		(LCD)	(touch panel)	(power supply)	(other)
			SP		5	4: 7" 6: 12" 7: 15"	90: eXtreme		W: Wide TFT	A: Analog	D: DC	F0H: Harsh environment model

### Model List

Series		Model names	Model numbers
SP5000X Series	eXtreme Box	SP-5B90	PFXSP5B90 PFXSP5B90F0H
	eXtreme Display	SP-5490WA	PFXSP5490WAD PFXSP5490WADF0H
		SP-5690WA	PFXSP5690WAD PFXSP5690WADF0H
		SP-5790WA	PFXSP5790WAD PFXSP5790WADF0H

**NOTE:** You can connect any eXtreme Display to eXtreme Box.

### Global Code

A global code is assigned to every Pro-face product as a universal model number. For more information on product models and their matching global codes, please refer to the following URL.

<http://www.pro-face.com/trans/en/manual/1003.html>

## Package Contents

**NOTE:** This product has been carefully packed with special attention to quality. However, should you find anything damaged or missing, please contact customer support immediately.

### Box Module

Verify all items listed here are present in your package:

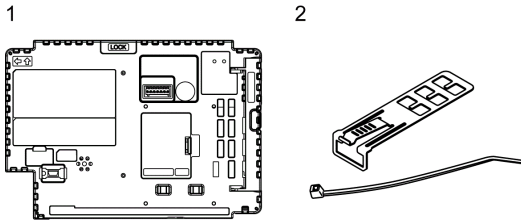

- 1 SP5000X Series eXtreme Box: 1
- 2 USB Clamp Type A (1 port): 2 sets (1 set = 1 clip and 1 tie)
- 3 Installation Guide: 1
- 4 Warning/Caution Information: 1

### Display Module

Verify all items listed here are present in your package:

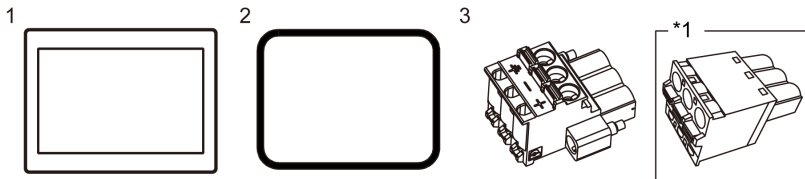

- 1 SP5000X Series eXtreme Display: 1
  - 2 Installation Gasket: 1 (attached to this product)
  - 3 DC Power Supply Connector (Right-angle<sup>\*1</sup>): 1
  - 4 Installation Guide: 1
  - 5 Warning/Caution Information: 1
- \*1 Straight type for SP-5490WA.

### Revision

You can identify the product version (PV), revision level (RL), and the software version (SV) from the product label.

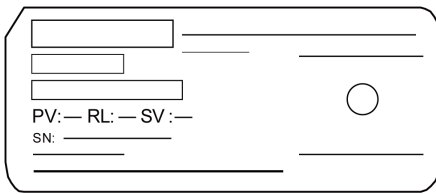
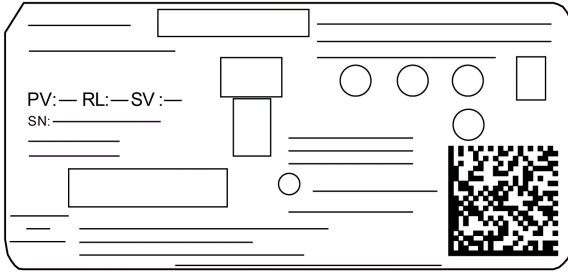

## Certifications and Standards

Some products are not subject to certification and standards. And some products have not received their certification and standards but are scheduled for assessment.

The certifications and standards listed below may include those that are not yet acquired for this product. For the latest certifications and standards that this product has acquired, please check the product marking or the following URL.

<http://www.pro-face.com/trans/en/manual/1002.html>

### Agency Certifications

- Underwriters Laboratories Inc., UL 61010-2-201 and CSA C22.2 N°61010-2-201, Industrial Control Equipment
- Underwriters Laboratories Inc., UL 121201 and CSA C22.2 N°213, Electrical Equipment for Use in Class I, Division 2 Hazardous (Classified) Locations
- IECEx / ATEX for use in zones 2/22
- EAC certification (Russia, Belarus, Kazakhstan)

### Compliance Standards

Europe:

CE

- Directive 2014/30/EU (EMC)
  - Programmable Controllers: EN 61131-2
  - EN61000-6-4
  - EN61000-6-2
- Directive 2014/34/EU (ATEX)
  - EN60079-0
  - EN60079-15
  - EN60079-31

Australia

- RCM
  - AS/NZS CISPR11 (EN55011)

Korea

- KC
  - KN11
  - KN61000-6-2

### Qualifications Standards

Schneider Electric voluntarily tested this product to additional standards. The additional tests performed, and the standards under which the tests were conducted, are specifically identified in Structural Specifications (*see page 40*).

### Hazardous Substances

This product is designed to be compliant with the following environmental regulations, even if the product may not fall directly in the scope of the regulation:

- WEEE, Directive 2012/19/EU
- RoHS, Directive 2011/65/EU and 2015/863/EU
- RoHS China, Standard GB/T 26572
- REACH regulation EC 1907/2006

### End of Life (WEEE)

The product contains electronic boards. It must be disposed of in specific treatment channels. The product contains cells and/or storage batteries which must be collected and processed separately when they have run out and at the end of product life (Directive 2012/19/EU).

Refer to Maintenance (*see page 103*) when extracting cells and batteries from the product. These batteries do not contain a weight percentage of heavy metals over the threshold notified by European Directive 2006/66/EC.

### European (CE) Compliance

The product described in this manual comply with the European Directives concerning Electromagnetic Compatibility and Low Voltage (CE marking) when used as specified in the relevant documentation, in application for which they are specifically intended, and in connection with approved third-party products.

### KC Markings

#### 사용자안내문

기종별	사용자안내문
A급 기기 (업무용 방송통신기자재)	이 기기는 업무용(A급) 전자파적합기기로서 판매자 또는 사용자는 이 점을 주의하시기 바라며, 가정외의 지역에서 사용하는 것을 목적으로 합니다.



## Federal Communication Commission Radio Frequency Interference Statement - For USA

### FCC Radio Interference Information

This product has been tested and found to comply with the Federal Communications Commission (FCC) limits for a Class A digital device, pursuant to Part 15 of the FCC Rules. These limits are designed to provide reasonable protection against harmful interference in a commercial, industrial or business environment. This product generates, uses, and can radiate radio frequency energy and, if not installed and used in accordance with the instructions, may cause or be subject to interference with radio communications. To minimize the possibility of electromagnetic interference in your application, observe the following two rules:

- Install and operate this product in such a manner that it does not radiate sufficient electromagnetic energy to cause interference in nearby devices.
- Install and test this product to ensure that the electromagnetic energy generated by nearby devices does not interfere with the operation of this product.
- Changes or modifications not expressly approved by the party responsible for compliance could void the user's authority to operate this product.

### **WARNING**

#### **ELECTROMAGNETIC / RADIO INTERFERENCE**

Electromagnetic radiation may disrupt the operation of this product leading to unintended equipment operation. If electromagnetic interference is detected:

- Increase the distance between this product and the interfering equipment.
- Reorient this product and the interfering equipment.
- Reroute power and communication lines to this product and the interfering equipment.
- Connect this product and the interfering equipment to different power supplies.
- Always use shielded cables when connecting this product to a peripheral device or another computer.

**Failure to follow these instructions can result in death, serious injury, or equipment damage.**

## Hazardous Location Installation - For USA and Canada

### General

This product has been designed with the intention of meeting the requirements of Class I, Division 2 hazardous location application. Division 2 locations are those locations where ignitable concentrations of flammable substances are normally confined, prevented by ventilation, or present in an adjacent Class I, Division 1 location, but where an abnormal situation might result in intermittent exposure to such ignitable concentrations.

While this product is a non-incendive device under UL 121201 and CSA C22.2 N°213, it is not designed for, and should never be used within a Division 1 (normally hazardous) location.

This product is suitable for use in Class I, Division 2, Groups A, B, C, and D hazardous locations or in non-hazardous locations. Before installing or using this product, confirm that the UL 121201 or CSA22.2 N°213 certification appears on the product labeling.

**NOTE:** Some products are not yet rated as suitable for use in hazardous locations. Always use your product in conformance with the product labeling and this manual.

### DANGER

#### POTENTIAL FOR EXPLOSION

- Do not use this product in hazardous environments or locations other than Class I, Division 2, Groups A, B, C, and D.
- Substitution of any component may impair suitability for Class I, Division 2.
- Do not connect or disconnect this product unless power has been switched off or the area is known to be non-hazardous.
- Always confirm that this product is suitable for use in hazardous locations by checking the UL 121201 or CSA C22.2 N°213 certification appears on the product labeling.
- Do not install any Schneider Electric or OEM components, equipment, or accessories unless these have also been qualified as suitable for use in Class I, Division 2, Groups A, B, C, and D locations.
- Do not attempt to install, operate, modify, maintain, service, or otherwise alter this product except as permitted in this manual. Unpermitted actions may impair the suitability of this product for Class I, Division 2 operation.

**Failure to follow these instructions will result in death or serious injury.**

 **DANGER****POTENTIAL FOR EXPLOSION**

- Always confirm the UL 121201 or CSA C22.2 N°213 hazardous location rating of your device before installing or using it in a hazardous location.
- To apply or remove the supply power from this product installed in a Class I, Division 2 hazardous location, you must either:
  - Use a switch located outside the hazardous environment, or;
  - Use a switch certified for Class I, Division 1 operation inside the hazardous area.
- Do not connect or disconnect equipment unless power has been switched off or the area is known to be non-hazardous. This applies to all connections including power, ground, serial, parallel, and network connections.
- Never use unshielded / ungrounded cables in hazardous locations.
- Use only non-incendive USB devices.
- When enclosed, keep enclosure doors and openings closed at all times to avoid the accumulation of foreign matter inside the workstation.

**Failure to follow these instructions will result in death or serious injury.**

 **DANGER****HAZARD OF ELECTRIC SHOCK, EXPLOSION, OR ARC FLASH**

- Remove all power from the device before removing any covers or elements of the system, and prior to installing or removing any accessories, hardware, or cables.
- Unplug the power cable from both this product and the power supply prior to installing or removing the product.
- Always use a properly rated voltage sensing device to confirm power is off where and when indicated.
- Replace and secure all covers or elements of the system before applying power to this product.
- Use only the specified voltage when operating this product. This product is designed to use 12 to 24 Vdc. Always check whether your device is DC powered before applying power.

**Failure to follow these instructions will result in death or serious injury.**

Make sure that this product is properly rated for the location. If the intended location does not presently have a Class, Division and Group rating, then users should consult the appropriate authorities having jurisdiction in order to determine the correct rating for that hazardous location.

## Operation and Maintenance

The systems have been designed for compliance with relevant spark ignition tests.

### DANGER

#### POTENTIAL FOR EXPLOSION

In addition to the other instructions in this manual, observe the following rules when installing this product in a hazardous location:

- Wire the equipment in accordance with the National Electrical Code article 501.10 (B) for Class I, Division 2 hazardous locations.
- Install this product in an enclosure suitable for the specific application. IP66F, IP67F, Type 4X (indoor and outdoor use), Type 12 and Type 13 enclosures are recommended even when not required by regulations.

**Failure to follow these instructions will result in death or serious injury.**

**NOTE:** IP66F and IP67F are not part of UL certification.

---

# Chapter 2

## Device Connectivity

---

### What Is in This Chapter?

This chapter contains the following topics:

Topic	Page
System Design	22
Accessories	24

## System Design

### Box Module

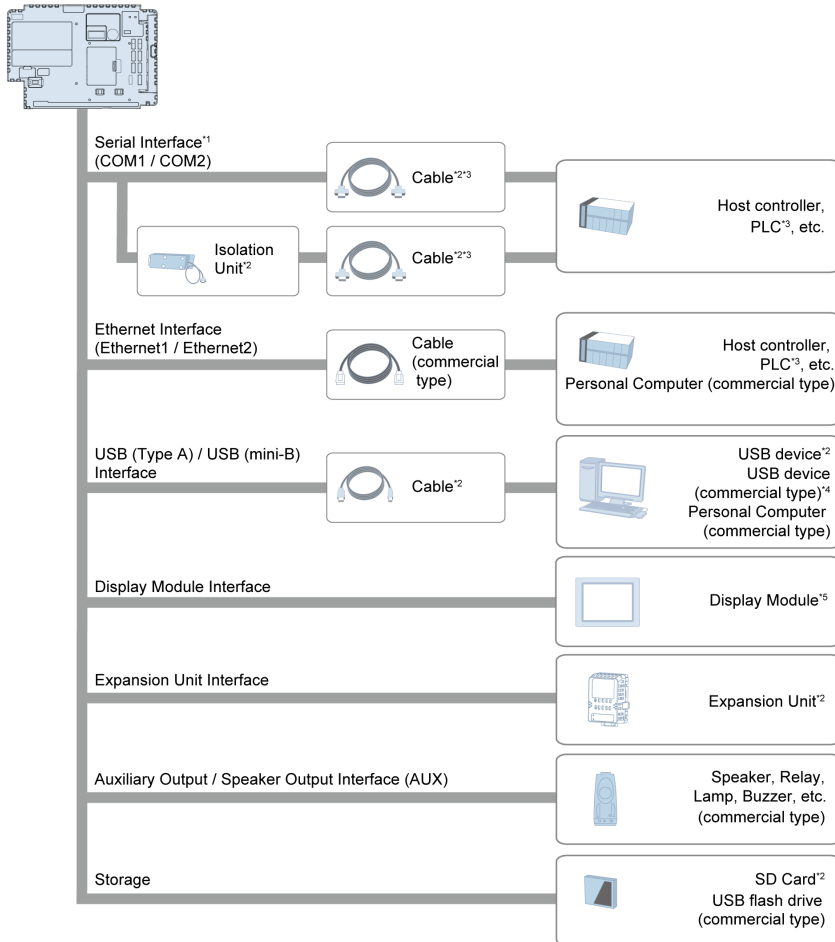

\*1 In order to use this as an isolation port, Isolation Unit is required. To use RS-232C isolation unit, set the #9 pin of the COM port to VCC.

\*2 Refer to Accessories (*see page 24*).

\*3 For information on how to connect controllers and other types of equipment, refer to the corresponding device driver manual of your screen editing software.

\*4 For supported models, refer to our support site at <http://www.pro-face.com/trans/en/manual/1001.html>.

\*5 Connects only to eXtreme Display. Refer to the Model Numbers (*see page 12*).

## Display Module



\*1 Connects only to eXtreme Box.

## Accessories

For host controllers and connection cables, refer to the corresponding device driver manual of your screen editing software.

Product name	Product number	Supported product	Description
<b>Serial interface</b>			
9-pin-to-25-pin RS-232C Conversion Cable (0.2 m)	CA3-CBLCBT232-01	Box Module	Cable for converting a D-Sub 9-pin plug to a D-Sub 25-pin socket (RS-232C).
RS-422 9/25-pin Conversion Cable (0.2 m)	PFXZCBCBCVR41	Box Module	Cable for converting a D-Sub 9-pin plug to a D-Sub 25-pin socket (RS-422).
COM Port Conversion Adapter	CA3-ADPCOM-01	Box Module	Connects optional RS-422 communication items to serial interface.
RS-422 Terminal Block Conversion Adapter	PFXZCBADTM1	Box Module	Connects output from a serial interface (D-sub 9 pin plug) directly to an RS-422 terminal block.
RS-232C Isolation Unit	CA3-ISO232-01	Box Module	Connects a host controller to this product and provides isolation. (RS-232C and RS-422 are switchable).
<b>USB (Type A) interface</b>			
USB Transfer Cable (2 m) <sup>*1 *3</sup>	CA3-USBCB-01	Box Module	Downloads project data via USB Interface.
USB Cable (5 m) <sup>*3</sup>	FP-US00	Box Module	Connects a USB printer (Type B).
USB Front Cable (1 m)	CA5-USBEXT-01	Box Module	Extension cable that attaches USB interface to front panel.
USB-Serial (RS-232C) Conversion Cable (0.5 m) <sup>*3</sup>	CA6-USB232-01	Box Module	Cable for converting a USB interface into a serial interface (RS-232C). Allows connection to modems <sup>*2</sup> or bar code readers <sup>*2</sup> that support RS-232C.
USB/RS-422/485 Conversion Adapter <sup>*3</sup>	PFXZCBCBCVUSR41	Box Module	Adapter for connecting this product (USB Type A) to an external device (RS-422/RS-485).
EZ Illuminated Switch <sup>*3</sup>	PFXZCCEUSG1	Box Module	A unit of 5 illuminated switches with multiple color LED connected to this product via USB.
EZ Fingerprint Recognition Unit <sup>*3</sup>	PFXZCCEUSS1	Box Module	Fingerprint recognition unit connected to this product via USB.
EZ Numpad <sup>*3</sup>	PFXZCCEUKB1	Box Module	Numpad connected to this product via USB.
EZ Tower Light tube mounting with fixing plate <sup>*3</sup>	PFXZCETWHA1	Box Module	USB Connection Type Monolithic EZ Tower Light tube mounting with fixing plate 3 tiers, Ø60, lighting and flashing with a buzzer



Product name	Product number	Supported product	Description
EZ Tower Light with base mounting <sup>*3</sup>	PFXZCETWW1	Box Module	USB Connection Type Monolithic EZ Tower with base mounting 3 tiers, Ø60, lighting and flashing with a buzzer
<b>USB (mini-B) interface</b>			
USB Transfer Cable (USB Type A/mini-B) (1.8 m) <sup>*1</sup>	ZC9USCBMB1	Box Module	Cable for transferring screen data from a PC (USB Type A) to this product (USB mini-B).
USB Panel-mount Extension Cable (USB mini-B) (1 m)	ZC9USEXMB1	Box Module	Extension cable that attaches to the USB (mini-B) interface on the front side of the operation panel.
USB Clamp mini-B (1 port)	ZC9USCLMB1	Box Module	Clamp to prevent disconnection of USB cable (USB/mini-B, 1 port, 5 clamps/set).
<b>Expansion unit interface</b>			
PROFIBUS DP Slave/MPI Unit <sup>*3</sup>	PFXZCDEUPF1	Box Module	Expansion unit that enables participation of this product in the PROFIBUS network and communication with the PROFIBUS DP master or in the MPI network (communication speed: 12 Mbps).
Flex Network Master Unit <sup>*3</sup>	PFXZCHEUFN1	Box Module	Expansion unit that enables participation of this product in the Flex network.
CANopen Master Unit <sup>*3</sup>	PFXZCHEUCAM1	Box Module	Expansion unit that enables participation of this product in the CANopen network and communication with the CANopen slave.
J1939 Unit <sup>*3</sup>	PFXZCHEUJ1	Box Module	Expansion unit that enables participation in the J1939 communication network.
<b>Auxiliary output/Speaker output interface</b>			
AUX Connector	PFXZCDCNAUX1	Box Module	AUX connector required in case an external output is used (5 pcs/set).
<b>Storage</b>			
SD Memory Card (4 GB) for Storage <sup>*4 *5</sup>	PFXZCBSD4GC41	Box Module	SD Memory Card (4 GB, MLC) (Storage)
<b>Others</b>			
Battery for Memory Backup	PFXZCBBT1	Box Module	Primary battery for time data backup (1 piece)
Box Module Fixing Bracket	PFXZCHBMFBS1	7-inch Wide Display Module	Bracket for fixing Box Module to Display Module (1 piece)
	PFXZCHBMFBL1	12-inch Wide Display Module/15-inch Wide Display Module	

Product name	Product number	Supported product	Description
DC Power Supply Connector with fixable screws	CA7-ACCNL-01	Display Module (except 7-inch Wide Display Module)	Connector to connect DC power supply cables (5 pcs/set)

\*1 You can connect using just one of the available USB (Type A/mini-B) interfaces.

\*2 For supported models, refer our support site at <http://www.pro-face.com/trans/en/manual/1001.html>.

\*3 Make sure your screen editing software supports the product.

\*4 You can also use a commercial type.

\*5 SD/SDHC card of up to 32 GB.

### Maintenance Accessories

Product name	Product number	Supported product	Description
Installation Gasket	PFXZCDWG72	7-inch Wide Display Module	Provides dust and moisture resistance when this product is installed into a solid panel (1 piece)
	PFXZCDWG122	12-inch Wide Display Module	
	PFXZCHWG154	15-inch Wide Display Module	
DC Power Supply Connector	PFXZCBCNDC1	Display Module	Connector to connect DC power supply cables (5 pcs/set)
DC Power Supply Connector with fixable screws (Angle type)	PFXZCHCNDC3	Display Module (except 7-inch Wide Display Module)	Connector with fixable screws to connect DC power supply cables (Angle type, 5 pcs/set)
USB Clamp Type A (1 port)	PFXZCBCLUSA1	Box Module	Clamp to prevent disconnection of USB cable (USB Type A, 1 port, 5 clamps/set)
SD Memory Card (1 GB) for System Card	PFXZCDS1GC61	Box Module	SD memory card (1 GB, SLC) for System Card

---

# Chapter 3

## Parts Identification and Functions

---

### What Is in This Chapter?

This chapter contains the following sections:

Section	Topic	Page
3.1	Parts Identification	28
3.2	LED Indications	33

# Section 3.1

## Parts Identification

---

### What Is in This Section?

This section contains the following topics:

Topic	Page
SP-5B90	29
SP-5490WA	31
SP-5690WA/5790WA	32

SP-5B90

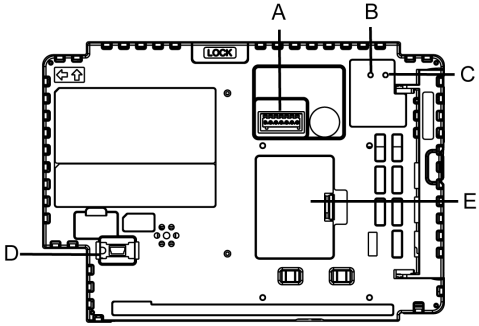
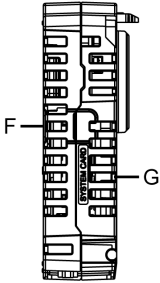
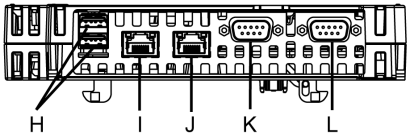
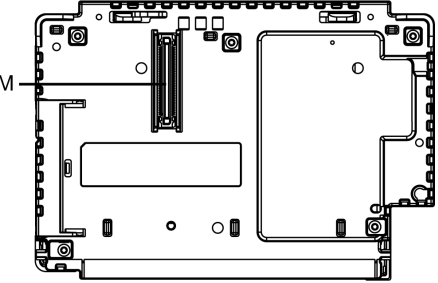
Side	SP-5B90
Front	 <p>A: Auxiliary output/ Speaker output interface (AUX)          B: Status LED*<sup>1</sup>          C: Card access LED*<sup>1</sup>          D: Lock mechanism          E: Internal connector</p>
Right	 <p>F: Edge connector          G: Edge connector</p>
Bottom	 <p>H: USB port          I: Ethernet port          J: Ethernet port          K: Serial port          L: Serial port</p>
Rear	 <p>M: Rear panel connector</p>

- A: Auxiliary output/ Speaker output interface (AUX)  
 This interface is alarm output or buzzer output, and sound output.
- B: Status LED\*<sup>1</sup>
- C: Card access LED\*<sup>1</sup>

D: USB (mini-B) interface<sup>\*2</sup>

E: Expansion unit interface cover (EXT)<sup>\*3</sup>

The expansion unit can be embedded in the expansion unit interface cover opening, and battery for memory backup can be connected or replaced.

F: Storage card cover

G: System card cover

You cannot open this cover when the Box Module is in operation.

H: USB (Type A) interface<sup>\*2</sup>

I: Ethernet interface (Ethernet1)<sup>\*2</sup>

J: Ethernet interface (Ethernet2)<sup>\*2</sup>

K: Serial interface (COM1)<sup>\*2</sup>

L: Serial interface (COM2)<sup>\*2</sup>

M: Display Module interface

\*1 Refer to LED Indications (*see page 33*)

\*2 Refer to Interface Specifications (*see page 46*)

\*3 Refer to Replacing the Primary Battery (*see page 107*)

## SP-5490WA

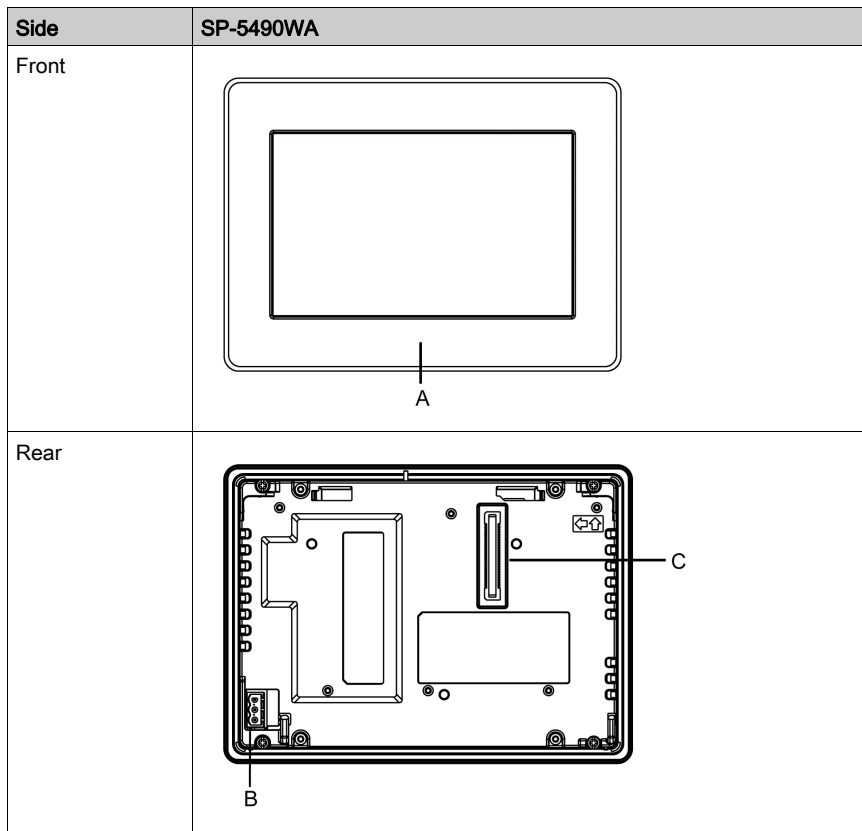

A: Bezel (stainless steel)

B: Power plug connector

C: Box Module interface

## SP-5690WA/5790WA

**NOTE:** The figures below show SP-5690WA.

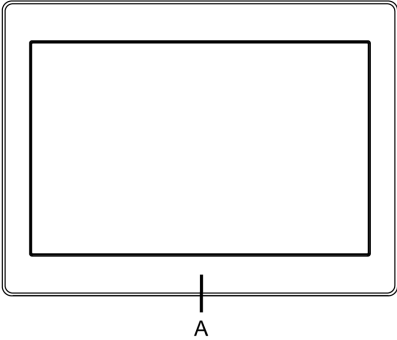
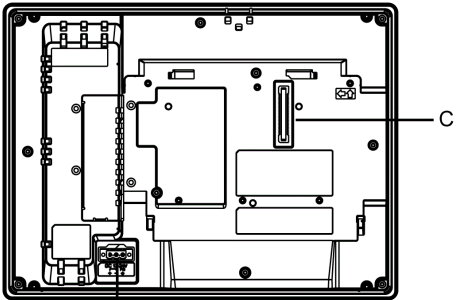
Side	SP-5690WA/5790WA
Front	 <p>A</p>
Rear	 <p>B</p> <p>C</p>

A: Bezel (stainless steel)

B: Power plug connector

C: Box Module interface



## Section 3.2

### LED Indications

#### LED Indications

##### Status LED

Color	Indicator	SP-5B90	
		HMI operation	Logic program operation <sup>*1</sup>
Green	ON	Offline	-
		In operation	RUN
	Flashing <sup>*1</sup>	In operation	STOP
Orange	Flashing	Software starting up	
Red	ON	Power is ON.	
	Flashing <sup>*1</sup>	In operation	Major error
Red/Green	Alternating	Display Module connection error	
Orange/Red	Alternating	SD card boot error	
-	OFF	Power is OFF.	

\*1 Only when your screen editing software supports the Logic Program.

##### Card Access LED

Color	Indicator	SP-5B90
Green	ON	Storage card is inserted.
-	OFF	Storage card is not inserted or is not detected.



---

# Chapter 4

## Specifications

---

### What Is in This Chapter?

This chapter contains the following sections:

Section	Topic	Page
4.1	General Specifications	36
4.2	Functional Specifications	42
4.3	Interface Specifications	46

# Section 4.1

## General Specifications

---

### What Is in This Section?

This section contains the following topics:

Topic	Page
Electrical Specifications	37
Environmental Specifications	38
Structural Specifications	40

## Electrical Specifications

### Box Module

Specification		SP-5B90
Rated Input Voltage		12 Vdc (Supply from Display Module)
Power consumption (primary power supply including power loss)	Max	20 W

### Display Module

Specification		SP-5490WA	SP-5690WA	SP-5790WA
Rated input voltage		12...24 Vdc		
Input voltage limits		10.8...28.8 Vdc		
Voltage drop		12 Vdc: 1.25 ms or less 24 Vdc: 5 ms or less		
Power consumption	Max*1	29 W	37 W	48 W
	When power is not supplied to external devices*1	17.5 W or less	23 W or less	34 W or less
	When screen turns off the backlight (standby mode)*1 (Power is not supplied to external devices)	12.5 W or less	12.5 W or less	12.5 W or less
	When screen backlight 20%*1 (Power is not supplied to external devices)	15 W or less	16 W or less	19 W or less
In-rush current		30 A or less		
Noise immunity		Noise voltage: 1,000 Vp-p Pulse duration: 1 μs Rise time: 1 ns (via noise simulator)		
Dielectric Strength		1,000 Vac for 1 minute (between power terminal and FG terminal), leakage current: 20 mA or less		
Insulation resistance		500 Vdc, 10 MΩ or more (between power terminal and FG terminal)		

\*1 The power consumption is the sum of the power consumption of Box Module and Display Module.

## Environmental Specifications

**NOTE:**

- Box Module environmental specifications follow those of the connected Display Module.
- When using any of the options for this product, check the specifications for special conditions or cautions that may apply to this product.

### Display Module

Specification	SP-5490WA	SP-5690WA	SP-5790WA
<b>Physical environment</b>			
Ambient air temperature* <sup>1</sup>	-30...65 °C (-22...149 °F) (T4) When installing and wiring: -5...65 °C (23...149 °F)	-30...70 °C (-22...158 °F) (T4) When installing and wiring: -5...70 °C (23...158 °F)	-20...60 °C (-4...140 °F) (T4) When installing and wiring: -5...60 °C (23...140 °F)
Storage temperature* <sup>1</sup>	-30...70 °C (-22...158 °F)	-30...70 °C (-22...158 °F)	-20...60 °C (-4...140 °F)
Ambient air and storage humidity	10%...90% RH (Non condensing, wet bulb temperature 39 °C [102.2 °F] or less)		
Dust	0.1 mg/m <sup>3</sup> (10 <sup>-7</sup> oz/ft <sup>3</sup> ) or less (free of conductive dust particles on all surfaces other than the front face)		
Pollution degree	3 for front face, 2 for other sides.		
Corrosive gases	Free of corrosive gases Model numbers ending in "F0H": IEC/EN 60721-3-3 Class 3C3* <sup>2</sup>		
Atmospheric pressure (operating altitude)	800...1,114 hPa (2,000 m [6,561 ft] or lower)		
UV resistance (front side)	Cutoff: 99% or more (380 nm)		
<b>Mechanical environment</b>			
Vibration resistance* <sup>1</sup>	IEC 60068-2-6 compliant 5...9 Hz Single amplitude 7 mm (0.28 in) 9...150 Hz Fixed acceleration: 19.6 m/s <sup>2</sup> X, Y, Z directions for 10 cycles (approximately 100 minutes) IEC 61373: 1999 (Category 1, Class B) 5≤f≤150 Hz (weight < 500 kg: f1=5 Hz, f2=150 Hz) acceleration: Up and down: 7.90 m/s <sup>2</sup> , Right and left: 3.50 m/s <sup>2</sup> , Back and forward: 5.50 m/s <sup>2</sup>		IEC 60068-2-6 compliant 5...9 Hz Single amplitude 3.5 mm (0.14 in) 9...150 Hz Fixed acceleration: 9.8 m/s <sup>2</sup> X, Y, Z directions for 10 cycles (approximately 100 minutes) IEC 61373: 1999 (Category 1, Class B) 5≤f≤150 Hz (weight < 500 kg: f1=5 Hz, f2=150 Hz) acceleration: Up and down: 7.90 m/s <sup>2</sup> , Right and left: 3.50 m/s <sup>2</sup> , Back and forward: 5.50 m/s <sup>2</sup>
Shock resistance* <sup>1</sup>	IEC 60068-2-27 compliant 392 m/s <sup>2</sup> , 11 ms, X, Y, Z directions for 3 times		IEC 60068-2-27 compliant 147 m/s <sup>2</sup> , X, Y, Z directions for 3 times

Specification	SP-5490WA	SP-5690WA	SP-5790WA
<b>Electrical environment</b>			
Electronic fast transient/burst immunity	IEC 61000-4-4 2 kV: Power port 1 kV: Signal ports		
Electrostatic discharge immunity	Contact discharge method: 6 kV Air discharge method: 8 kV (IEC/EN 61000-4-2 Level 3)		

\*1 When using a Fieldbus unit, use this product within the specifications of the Fieldbus unit.

\*2 For use in more severe environments, products with model numbers that end in "F0H" have conformal coating of electronic boards. Test levels are as follows.

Model	Standard	Levels
Products with model numbers that end in "F0H"	IEC/EN 60721-3-3	Flowing mixed gas; class 3C3, 25 °C (77 °F), 75% relative humidity, t = 7 days Concentrations (ppm): H <sub>2</sub> S: 2.5 / Cl <sub>2</sub> : 0.1 / SO <sub>2</sub> : 2.0

Apply grease (Nyogel 760G) for corrosion prevention to the following interface points.

Box Module	Display module interface, expansion unit interface, Ethernet interface x 2, USB (Type A) interface x 2, USB (mini-B) interface, system card interface, storage card interface
Display Module	Box module interface

**Air quality requirements**

Do not operate or store the panel where chemicals evaporate, or where chemicals are present in the air:

- Corrosive chemicals: Acids, alkalines, liquids containing salt.
- Flammable chemicals: Organic solvents.

 <b>CAUTION</b>
<b>INOPERATIVE EQUIPMENT</b>
Do not allow water, liquids, metal, and wiring fragments to enter the panel case.
<b>Failure to follow these instructions can result in injury or equipment damage.</b>

## Structural Specifications

### Box Module

	SP-5B90
Cooling method	Natural air circulation
External dimensions (W x H x D)	188 x 131 x 35 mm (7.4 x 5.16 x 1.38 in)
Weight	0.9 kg (1.98 lb) or less

### Display Module

	SP-5490WA	SP-5690WA	SP-5790WA
Grounding	Functional grounding: Grounding resistance of 100 Ω or less, 2 mm <sup>2</sup> (AWG 14) or thicker wire, or your country's applicable standard (same for FG and SG terminals).		
Cooling method	Natural air circulation		
Structure *1	IP66F, IP67F, Type 4X (indoor and outdoor use), Type 12, Type 13* <sup>2</sup> * on the front panel when properly installed in an enclosure.		
External dimensions (W x H x D)	203.6 x 148.6 x 37 mm (8.02 x 5.85 x 1.45 in)	308 x 230.5 x 68 mm (12.15 x 9.07 x 2.68 in)	408 x 264 x 68 mm (16.06 x 10.39 x 2.68 in)
Panel cut dimensions (W x H)	190 x 135 mm (7.48 x 5.31 in)* <sup>3</sup> Panel thickness area: 1.6...5 mm (0.06...0.2 in)* <sup>4</sup>	295 x 217 mm (11.61 x 8.54 in)* <sup>3</sup> Panel thickness area: 1.6...5 mm (0.06...0.2 in)* <sup>4</sup>	394 x 250 mm (15.51 x 9.84 in)* <sup>3</sup> Panel thickness area: 1.6...5 mm (0.06...0.2 in)* <sup>4</sup>
Weight	1.3 kg (2.9 lb) or less	3.2 kg (7.1 lb) or less	4.8 kg (10.6 lb) or less
Front bezel materials	Aluminum die-cast Stainless steel		

\*1 The front face of this product, installed in a solid panel, has been tested using conditions equivalent to the standards shown in the specification. Even though this product's level of resistance is equivalent to these standards, oils that should have no effect on this product can possibly harm this product. This can occur in areas where either vaporized oils are present, or where low viscosity cutting oils are allowed to adhere to this product for long periods of time. If this product's front face protection sheet or cover glass peels off, these conditions can lead to the ingress of oil into this product and separate protection measures are suggested.

Also, if non-approved oils are present, they may cause deformation or corrosion of the front panel's cover. Therefore, prior to installing this product, be sure to confirm the type of conditions that will be present in this product's operating environment. If the installation gasket is used for a long period of time, or if this product and its gasket are removed from the panel, the original level of protection cannot be kept. To maintain the original protection level, be sure to replace the installation gasket regularly.

\*2 Check the model number and product version (PV) on the product label. If the product version is "PV: 01" and only with one of the following model numbers, the protection level is IP66F.

Model number: PFXSP5490WAD, PFXSP5690WAD

\*3 For dimensional tolerance, everything +1/-0 mm (+0.04/-0 in) and R in angle are below R3 (R0.12 in).



\*4 Even if the installation wall thickness is within the recommended range for the Panel Cut Dimensions (*see page 70*), depending on wall's material, size, and installation location of this product and other devices, the installation wall could warp. To prevent warping, the installation surface may need to be strengthened.

## ***NOTICE***

### **EQUIPMENT DAMAGE**

- Ensure this product is not in permanent and direct contact with oils.
- Do not press on the display of this product with excessive force or with a hard object.
- Do not press on the touch panel with a pointed object, such as the tip of a mechanical pencil or a screwdriver.

**Failure to follow these instructions can result in equipment damage.**

## ***NOTICE***

### **STORAGE AND OPERATION OUTSIDE OF SPECIFICATIONS**

- Store the panel in areas where temperatures are within the product's specifications.
- Do not restrict or block this panel's ventilation slots.

**Failure to follow these instructions can result in equipment damage.**

## ***NOTICE***

### **GASKET AGING**

- Inspect the gasket periodically as required by your operating environment.
- Change the gasket at least once a year, or as soon as scratches or dirt become visible.

**Failure to follow these instructions can result in equipment damage.**

# Section 4.2

## Functional Specifications

---

### What Is in This Section?

This section contains the following topics:

Topic	Page
Display Specifications	43
Touch Panel	44
Memory, Clock	45

## Display Specifications

	SP-5490WA	SP-5690WA	SP-5790WA
Display type	TFT Color LCD (High brightness)		
Display size	7"	12.1"	15.6"
Resolution	800 x 480 pixels (WVGA)	1,280 x 800 pixels (WXGA)	1,366 x 768 pixels (FWXGA)
Effective display area (W x H)	152.4 x 91.4 mm (6.00 x 3.60 in)	261.1 x 163.2 mm (10.28 x 6.43 in)	344.2 x 193.5 mm (13.55 x 7.62 in)
Display colors	262,144 colors		
Backlight	White LED (Not user replaceable. When replacement is required, contact customer support.)		
Backlight service life	50,000 hours or more (continuous operation at 25 °C [77 °F] before backlight brightness decreases to 50%)		
Brightness control	0...100 (Adjusted with touch panel or software)		
Brightness (LCD panel)	1000 cd/m <sup>2</sup> (Typ.)		

## Touch Panel

	<b>SP-5490WA/5690WA/5790WA</b>
Touch panel type	Analog resistive
Touch panel resolution	1,024 x 1,024
Touch panel service life	1 million times or more

The touch panel does not support multi-touch (two point touch / multiple point touch). If you touch multiple points on the touch panel, it may operate as if you touched the center-point of the multiple touches. For example, if you touch two or more points on the touch panel and at the center of the touches is a switch for a drive system, even though you did not directly touch that switch, it may function as if you did.

 <b>WARNING</b>
--

<b>UNINTENDED EQUIPMENT OPERATION</b>
---------------------------------------

Do not touch two or more points on the touch panel.
---

<b>Failure to follow these instructions can result in death, serious injury, or equipment damage.</b>
---

## Memory, Clock

### Memory

	SP-5B90
System card	SD Card 1 GB (operating system, project data <sup>*1</sup> , and other data)
Backup memory	NVRAM 512 KB <sup>*1</sup>

\*1 Amount of memory you can use depends on your screen editing software. For information refer to the manual of your screen editing software.

### Clock

±60 seconds per month (deviation at room temperature and power is OFF). Variations in operating conditions and battery life can cause clock deviations from -380 to +90 seconds per month.

For systems where this level of precision is insufficient, the user should monitor and make adjustments when required.

Backup clock data uses a supercapacitor (electric double-layer capacitor) for power. When the voltage from the supercapacitor is low, clock data is lost<sup>\*1</sup> when this product is turned OFF.

The average period for backup is as follows:

Initial: Approximately 100 days

After 5 years: Approximately 30 days (when used with an ambient temperature of 25 °C [77 °F])

\*1 If clock data is lost, a clock data error message appears when starting up this product. When this happens, leave this product ON for at least 5 minutes, and then set the clock again. Refer to your screen editing software manual on how to set up the clock.

By connecting the optional backup battery (model number: PFXACBBT1) for clock data backup, you can maintain a backup period of 5 years or more (when used with an ambient temperature of 25 °C [77 °F]). However, as the battery expires after 5 years, we recommend regularly changing the battery every 5 years.

# Section 4.3

## Interface Specifications

---

### What Is in This Section?

This section contains the following topics:

Topic	Page
Interface Specifications	47
Interface Connection	48
Serial Interface (RS-232C and RS-422/RS-485) for COM1/COM2	49
Auxiliary Output/Speaker Output Interface (AUX)	52

## Interface Specifications

### Box Module

SP-5B90	
<b>Serial interface COM1</b>	
Asynchronous transmission	RS-232C/422/485
Data length	7 or 8 bits
Stop bit	1 or 2 bits
Parity	None, odd, or even
Data transmission speed	2,400...115,200 bps
Connector	D-Sub 9 pin (plug)
<b>Serial interface COM2</b>	
Asynchronous transmission	RS-232C/422/485
Data length	7 or 8 bits
Stop bit	1 or 2 bits
Parity	None, odd, or even
Data transmission speed	2,400...115,200 bps, 187,500 bps (MPI)
Connector	D-Sub 9 pin (plug)
<b>USB (Type A) interface</b>	
Connector	USB 2.0 (Type A) x 2
Power supply voltage	5 Vdc $\pm$ 5%
Maximum current supplied	500 mA/port
Maximum transmission distance	5 m (16.4 ft)
<b>USB (mini-B) interface</b>	
Connector	USB 2.0 (mini-B) x 1
Maximum transmission distance	5 m (16.4 ft)
<b>Ethernet interface</b>	
Standard	IEEE802.3i/IEEE802.3u/IEEE802.3ab, 10BASE-T/ 100BASE-TX/ 1000BASE-T*1
Connector	Modular jack (RJ-45) x 2
<b>SD Card interface</b>	
SD Card	SD Card slot (System) x 1 SD Card slot (Storage) x 1
<b>Expansion unit interface</b>	
Expansion unit	Fieldbus unit x 1
<b>Sound output interface</b>	
Speaker output	300 mW or more (Rated Load: 8 $\Omega$ , Frequency: 1 kHz)
LINE output	1.4 Vp-p (Rated load: 10 k $\Omega$ )
Connector	2-piece terminal block (AUX) x 1
<b>AUX output interface</b>	
AUX output	Alarm output/Buzzer output
Rated voltage	24 Vdc
Rated current	50 mA
Connector	2-piece terminal block (AUX) x 1

\*1 For 1000BASE-T communication, use twisted pair Ethernet cables with a rating of category 5e or higher.

## Interface Connection

### Introduction

Use only the SELV (Safety Extra-Low Voltage) circuit to connect all interfaces on this product.

### Cable Connections

## DANGER

### POTENTIAL FOR EXPLOSION

- Always confirm the UL 121201 or CSA C22.2 N°213 hazardous location rating of your device before installing or using it in a hazardous location.
- To apply or remove the supply power from this product installed in a Class I, Division 2 hazardous location, you must either:
  - Use a switch located outside the hazardous environment, or;
  - Use a switch certified for Class I, Division 1 operation inside the hazardous area.
- Do not connect or disconnect equipment unless power has been switched off or the area is known to be non-hazardous. This applies to all connections including power, ground, serial, parallel, and network connections.
- Never use unshielded / ungrounded cables in hazardous locations.
- Use only non-incendive USB devices.
- Use the USB (mini-B) interface for temporary connection only during maintenance and setup of the device.
- Do not use the USB (mini-B) interface in hazardous locations.
- When enclosed, keep enclosure doors and openings closed at all times to avoid the accumulation of foreign matter inside the workstation.

**Failure to follow these instructions will result in death or serious injury.**

Division 2 hazardous location regulations require that all cable connections be provided with adequate strain relief and positive interlock. As this product does not provide adequate strain relief for the USB connection (USB mini-B interface) on this product, use only non-incendive USB devices. Never connect or disconnect a cable while power is applied at either end of the cable. All communication cables should include a chassis ground shield. This shield should include both copper braid and aluminum foil. The D-sub style connector housing must be a metal conductive type (for example, molded zinc) and the ground shield braid must be terminated directly to the connector housing. Do not use a shield drain wire.

The outer diameter of the cable must be suited to the inner diameter of the cable connector strain relief so that a reliable degree of strain relief is maintained. Always secure the D-sub connectors to the workstation-mating connectors via the two screws located on both sides.



## Serial Interface (RS-232C and RS-422/RS-485) for COM1/COM2

### Introduction

**NOTE:** For information on how to connect controllers and other types of equipment, refer to the corresponding device driver manual of your screen editing software.

You can switch the communication method between RS-232C and RS-422/RS-485 via the software.

The serial interface is not isolated. The SG (signal ground) and FG (functional ground) terminals are connected inside this product. When the serial interface connector is D-Sub, connect the FG wire to the shell.

### DANGER

#### ELECTRIC SHOCK AND FIRE

When using the SG terminal to connect an external device to this product:

- Verify that a ground loop is not created when you set up the system.
- Connect the SG terminal to remote equipment when the external device is not isolated.
- Connect the SG terminal to a known reliable ground connection to reduce the risk of damaging the circuit.

**Failure to follow these instructions will result in death or serious injury.**

### CAUTION

#### LOSS OF COMMUNICATION

- Do not put excessive stress on the communication ports of all connections.
- Securely attach communication cables to the panel wall or cabinet.
- Use a D-Sub 9 pin connector that has jack screws.

**Failure to follow these instructions can result in injury or equipment damage.**

**NOTE:** Use within the rated current.

**RS-232C**

D-Sub 9 pin plug connector

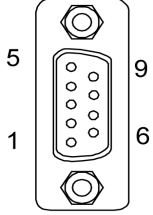
Product side	Pin No.	RS-232C		
		Signal name	Direction	Meaning
	1	CD	Input	Carrier Detect
	2	RD (RXD)	Input	Receive Data
	3	SD (TXD)	Output	Send Data
	4	ER (DTR)	Output	Data Terminal Ready
	5	SG	-	Signal Ground
	6	DR (DSR)	Input	Data Set Ready
	7	RS (RTS)	Output	Request to Send
	8	CS (CTS)	Input	Send possible
	9	CI (RI)/VCC	Input/-	Called Status Display +5 Vdc ±5% Output 0.25 A*1
	Shell	FG	-	Functional Ground (Common with SG)

\*1 You can switch pin #9 between CI (RI) and VCC via the software. The VCC output is not protected against overcurrent. To prevent damage or malfunction, use only within the rated current.

Interfit bracket is #4-40 (UNC).

Recommendations:

- Cable Connector: XM3D-0921 manufactured by OMRON Corporation.
- Cable Cover: XM2S-0913 manufactured by OMRON Corporation.
- Jack Screw (#4-40 UNC): XM2Z-0073 manufactured by OMRON Corporation.

**RS-422/485**

D-Sub 9 pin plug connector

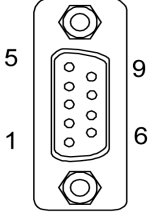
Product side	Pin No.	RS-422/RS-485		
		Signal name	Direction	Meaning
	1	RDA	Input	Receive Data A (+)
	2	RDB	Input	Receive Data B (-)
	3	SDA	Output	Send Data A (+)
	4	ERA	Output	Data Terminal Ready A (+)
	5	SG	-	Signal Ground
	6	CSB	Input	Send Possible B (-)
	7	SDB	Output	Send Data B (-)
	8	CSA	Input	Send possible A (+)
	9	ERB	Output	Data Terminal Ready B (-)
	Shell	FG	-	Functional Ground (Common with SG)

Interfit bracket is #4-40 (UNC).

Recommendations:

- Cable Connector: XM3D-0921 manufactured by OMRON Corporation.
- Cable Cover: XM2S-0913 manufactured by OMRON Corporation.
- Jack Screw (#4-40 UNC): XM2Z-0073 manufactured by OMRON Corporation.

## Auxiliary Output/Speaker Output Interface (AUX)



DANGER

**ELECTRIC SHOCK AND FIRE**

When using the SG terminal to connect an external device to this product:

- Verify that a ground loop is not created when you set up the system.
- Connect the SG terminal to remote equipment when the external device is not isolated.
- Connect the SG terminal to a known reliable ground connection to reduce the risk of damaging the circuit.

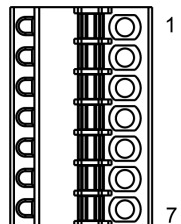
**Failure to follow these instructions will result in death or serious injury.**

Cable connection side	Pin No.	Signal name	Direction	Meaning
	1	LineOut	Output	Line Out
	2	LineOut_GND	Output	Line Out Ground
	3	SP+	Output	Speaker +
	4	SP-	Output	Speaker -
	5	NC	–	No Connection
	6	ALARM+/BUZZER+	Output	(Can be changed via software)
	7	ALARM-/BUZZER-	Output	

AUX Connector: PFXZCDCNAUX1 by Pro-face

Output Circuit

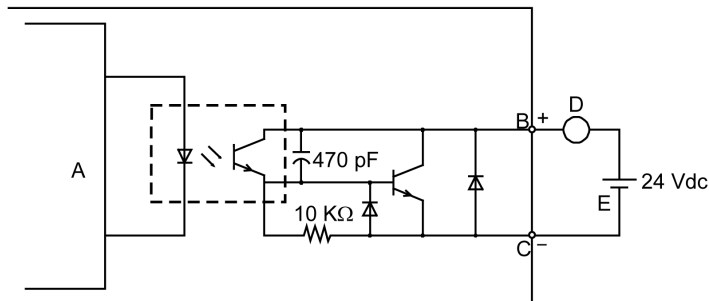

A Internal Circuit

B Pin Number 6: ALARM+/BUZZER+

C Pin Number 7: ALARM-/BUZZER-

D Load

E External Power

---

# Chapter 5

## Dimensions

---

### What Is in This Chapter?

This chapter contains the following topics:

Topic	Page
SP-5B90	54
SP-5490WA	55
SP-5690WA	58
SP-5790WA	61

# SP-5B90

## External Dimensions

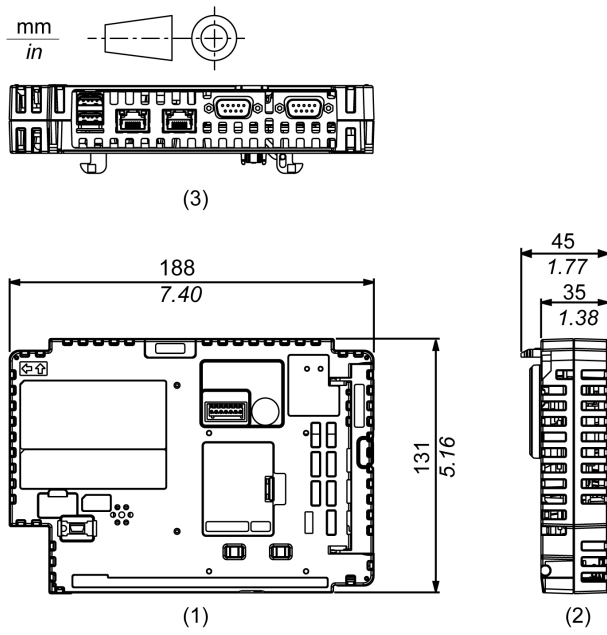

- 1 Front
- 2 Left
- 3 Bottom

# SP-5490WA

## External Dimensions

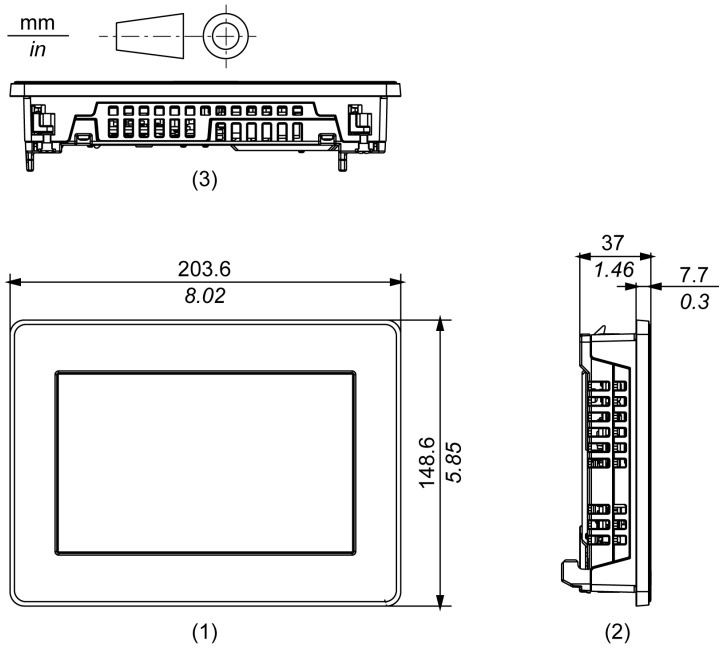

- 1 Front
- 2 Left
- 3 Bottom

Dimensions with Box Module

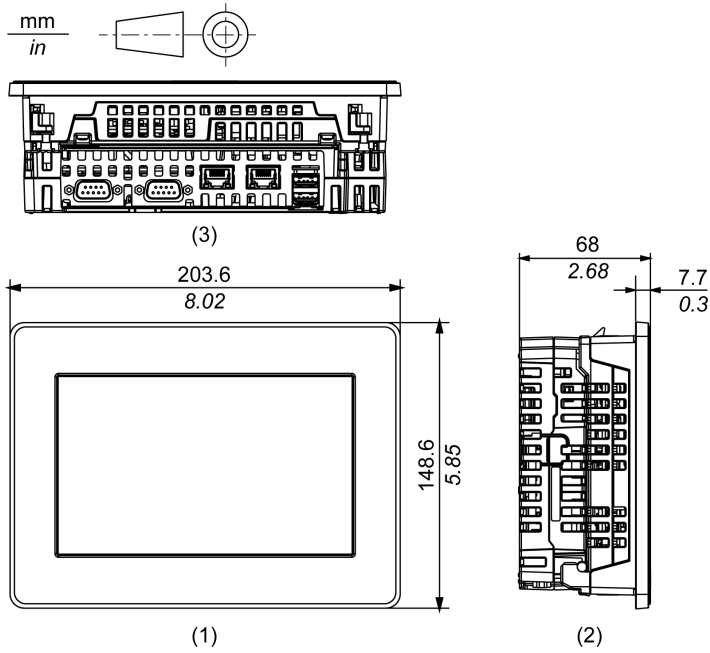

- 1 Front
- 2 Left
- 3 Bottom



Dimensions with Cables

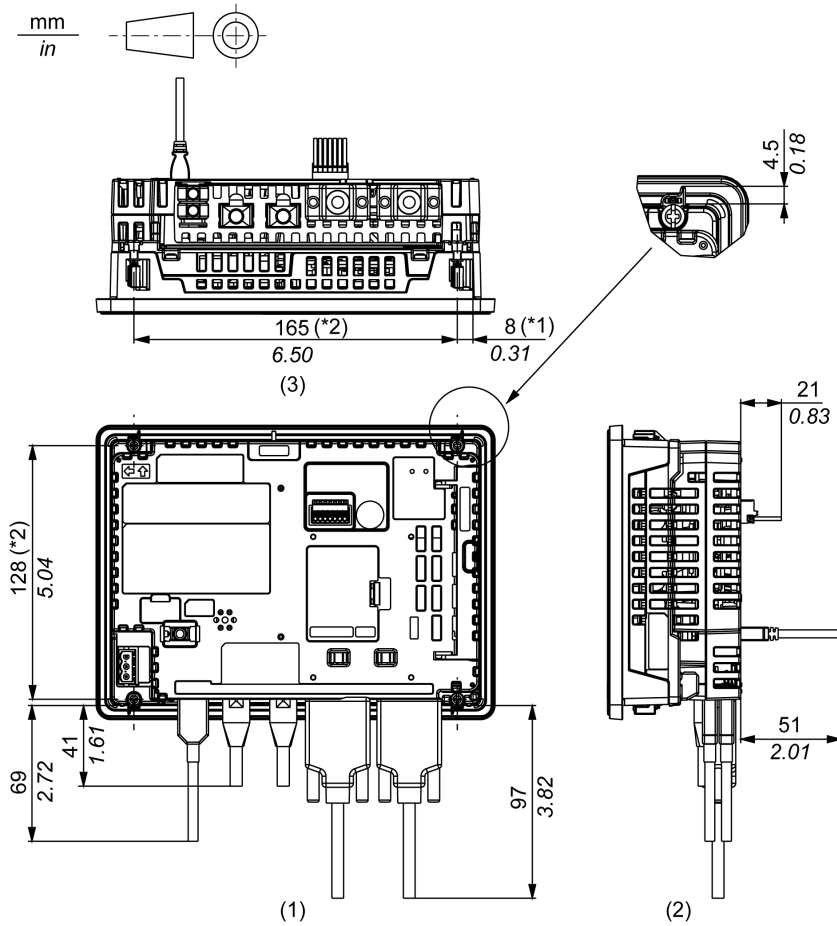

\*1 Rotation area of the fastener

\*2 Pitch of the enter of installation fastener screws

1 Rear

2 Right

3 Bottom

**NOTE:** All the above values are designed with cable bending in mind. The dimensions given here are representative values depending on the type of connection cable in use. Therefore, these values are intended for reference only.

# SP-5690WA

## External Dimensions

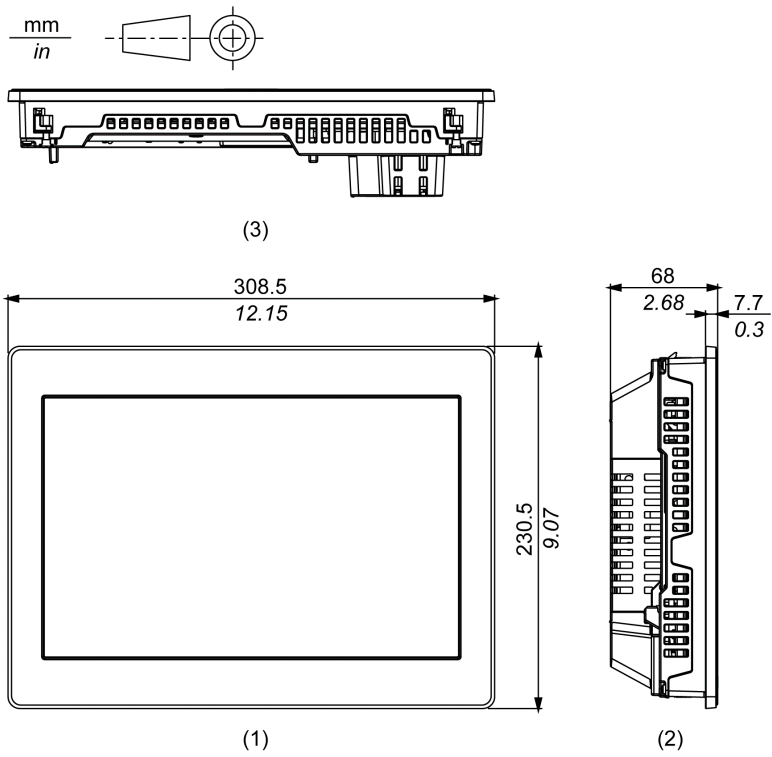

- 1 Front
- 2 Left
- 3 Bottom

**Dimensions with Box Module**

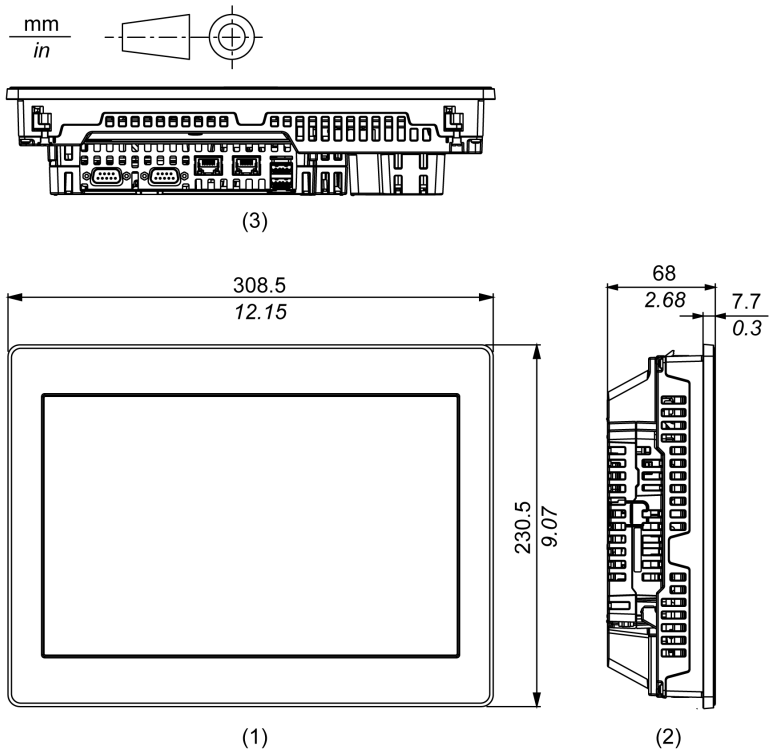

- 1 Front
- 2 Left
- 3 Bottom

Dimensions with Cables

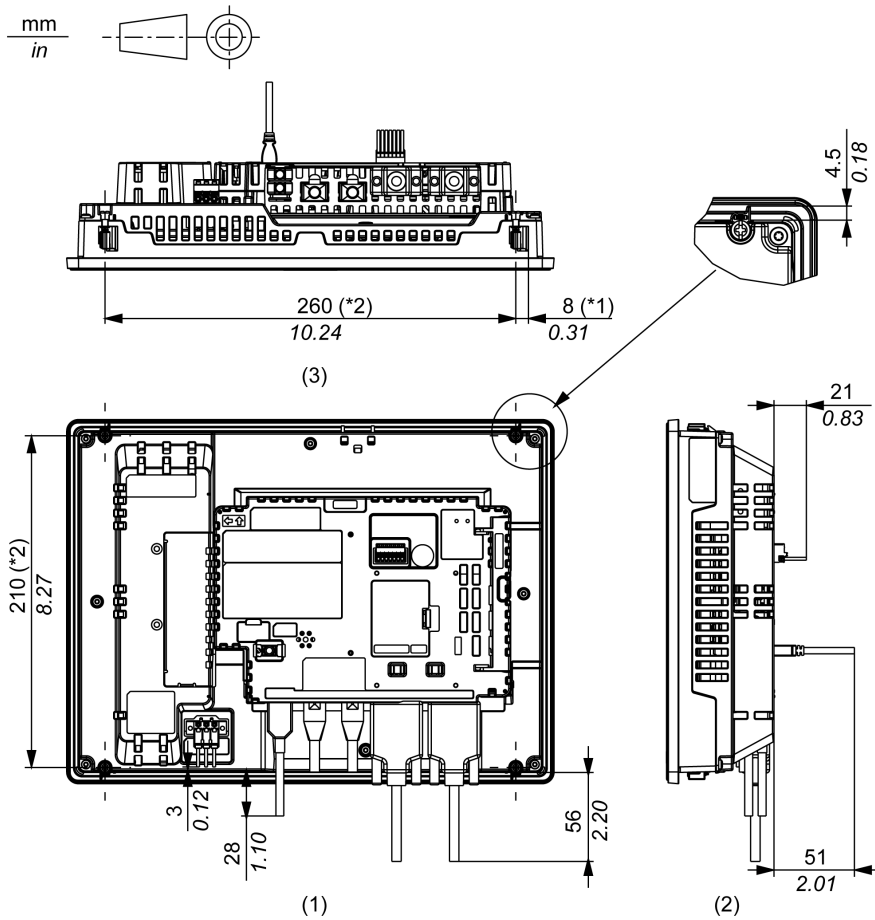

\*1 Rotation area of the fastener

\*2 Pitch of the enter of installation fastener screws

- 1 Rear
- 2 Right
- 3 Bottom

**NOTE:** All the above values are designed with cable bending in mind. The dimensions given here are representative values depending on the type of connection cable in use. Therefore, these values are intended for reference only.

# SP-5790WA

## External Dimensions

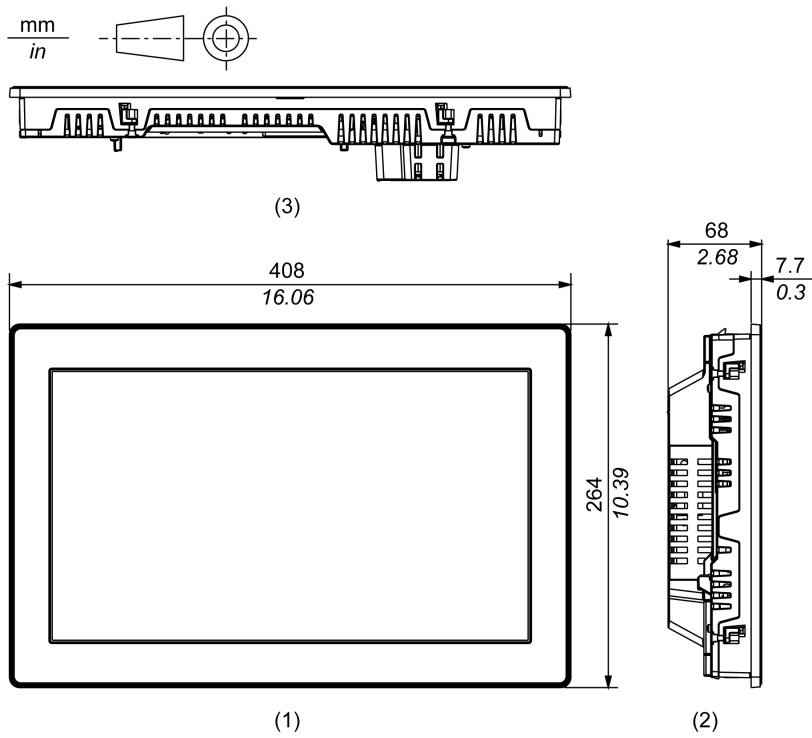

- 1 Front
- 2 Left
- 3 Bottom

Dimensions with Box Module

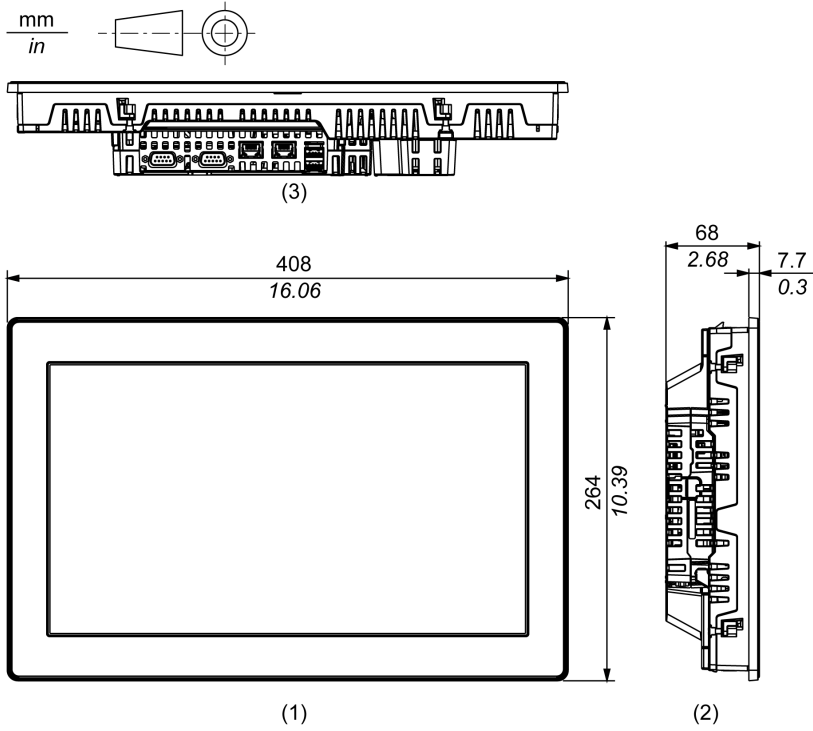

- 1 Front
- 2 Left
- 3 Bottom







---

# Chapter 6

## Installation and Wiring

---

### What Is in This Chapter?

This chapter contains the following sections:

Section	Topic	Page
6.1	Installation	66
6.2	Wiring Principles	82
6.3	USB Cable Clamp	89
6.4	AUX Connector	94
6.5	SD Card Insertion/Removal	95
6.6	Isolation Unit and USB/RS-422/485 Conversion Adapter	99

# Section 6.1

## Installation

---

### What Is in This Section?

This section contains the following topics:

Topic	Page
Introduction	67
Installation Requirements	68
Panel Cut Dimensions	70
Installing onto Display Module	71
Attaching Fixing Bracket (SP-5490WA)	73
Attaching Fixing Bracket (SP-5690WA/5790WA)	74
Removing from Display Module	75
Installing to the Panel	77
Removing from the Panel	80

## Introduction

This product is designed for use on flat surfaces of IP66F, IP67F, Type 4X (indoor and outdoor use), Type 12 and Type 13 enclosures.

Mount this product in an enclosure that provides a clean, dry, robust and controlled environment.

Be aware of the following when building this product into an end-use product:

- The rear face of eXtreme Display and all faces of eXtreme Box are not approved as an enclosure. When building this product into an end-use product, be sure to use an enclosure that satisfies standards as the end-use product's overall enclosure.
- Install this product in an enclosure with mechanical rigidity.
- The front face of eXtreme Display is designed for indoor and outdoor use, and for use in a wet location. UL certification obtained is for indoor and outdoor use for the front side, and indoor use only for other sides.
- eXtreme Box is not designed for outdoor use. UL certification obtained is for indoor use only.
- Install and operate this product with its front panel facing outward.

**NOTE:** IP66F and IP67F are not part of the UL certification.

## Installation Requirements

Check that the installation wall or cabinet surface is flat, in good condition and has no jagged edges. Metal reinforcing strips may be attached to the inside of the wall, near the panel-cut, to increase its rigidity.

Decide on the thickness of the enclosure wall, based on the level of strength required. Even if the installation wall thickness is within the recommended range for the Panel Cut Dimensions (see page 70), depending on wall's material, size, and installation location of this product and other devices, the installation wall could warp. To prevent warping, the installation surface may need to be strengthened.

Check that the ambient air temperature and the ambient humidity are within their specified ranges in Environmental Specifications (see page 38). When installing this product in a cabinet or enclosure, the ambient air temperature is the cabinet's or enclosure's internal and external temperature.

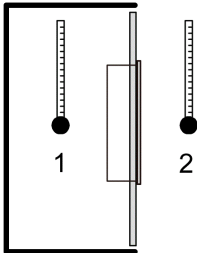

1 Internal temperature

2 External temperature

Be sure that heat from surrounding equipment does not cause this product to exceed its standard operating temperature.

When mounting this product vertically, ensure that the right side of this product faces up. In other words, the DC power connector should be at the top.

**NOTE:** For vertical mounting, make sure your screen editing software supports the function.

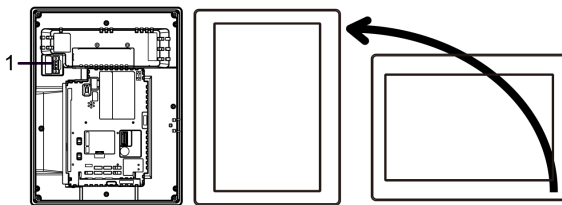

1 Power connector

When installing this product in a slanted position, the product face should not incline more than 30°.

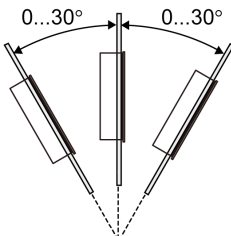

For easier maintenance, operation and improved ventilation, install this product at least 100 mm (3.94 in) away from adjacent structures and other equipment as shown in the following illustration:

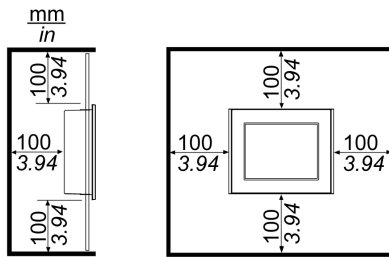

Please ensure you have enough space to insert and remove the storage card.

## Panel Cut Dimensions

Based on the panel cut dimensions, open a mount hole on the panel.

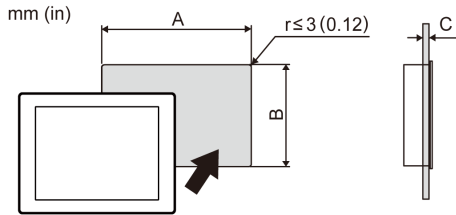

Model Name		
A	B	C
SP-5490WA		
190 mm (+1/-0 mm) (7.48 in [+0.04/-0 in])	135 mm (+1/-0 mm) (5.31 in [+0.04/-0 in])	1.6...5 mm (0.06...0.2 in)
SP-5690WA		
295 mm (+1/-0 mm) (11.61 in [+0.04/-0 in])	217 mm (+1/-0 mm) (8.54 in [+0.04/-0 in])	1.6...5 mm (0.06...0.2 in)
SP-5790WA		
394 mm (+1/-0 mm) (15.51 in [+0.04/-0 in])	250 mm (+1/-0 mm) (9.84 in [+0.04/-0 in])	1.6...5 mm (0.06...0.2 in)

## Installing onto Display Module

### **DANGER**

#### HAZARD OF ELECTRIC SHOCK, EXPLOSION, OR ARC FLASH

- Remove all power from the device before removing any covers or elements of the system, and prior to installing or removing any accessories, hardware, or cables.
- Unplug the power cable from both this product and the power supply prior to installing or removing the product.
- Always use a properly rated voltage sensing device to confirm power is off where and when indicated.
- Replace and secure all covers or elements of the system before applying power to this product.

**Failure to follow these instructions will result in death or serious injury.**

### *NOTICE*

#### EQUIPMENT DAMAGE

- When mounting this product vertically, before attaching to the panel, install the Box Module onto the Display Module.
- When installing the Box Module onto the Display Module, place the Display Module on a clean and level surface with the screen facing downward.

**Failure to follow these instructions can result in equipment damage.**

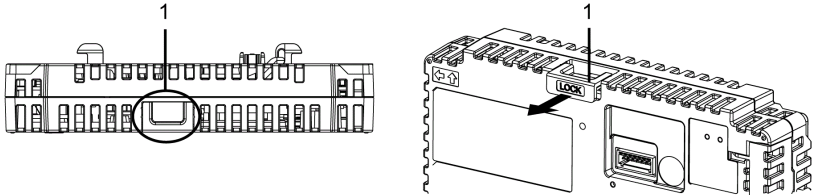
Step	Action
1	<p>Pull the LOCK forward on the top of the Box Module to release the lock as illustrated.</p>  <p>1 LOCK</p>

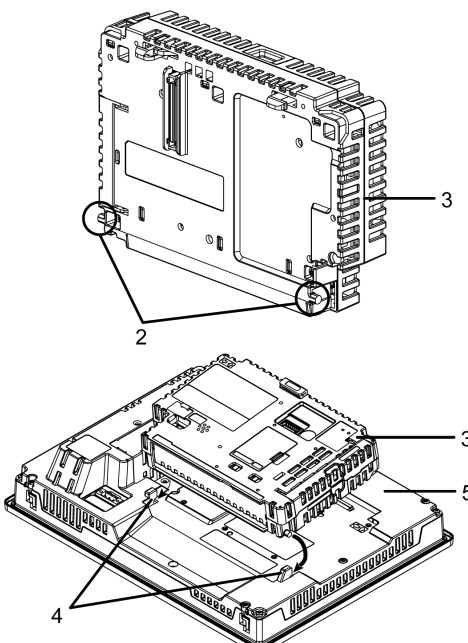
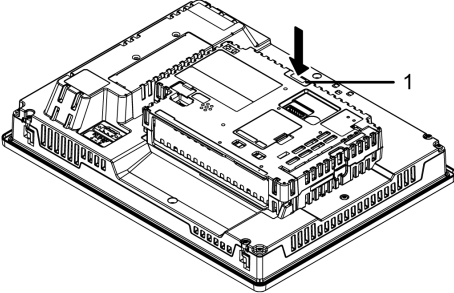
Step	Action
2	<p>Insert the protruding points on the bottom left and right of the Box Module into the two holes on the back of the Display Module to attach the Box Module.</p>  <p>2 Protruding points 3 Box Module 4 Holes for insertion 5 Display Module</p>
3	<p>Fully push on the LOCK on the top of the Box Module to mount the Box Module on the Display Module.</p>  <p>1 LOCK</p>

**NOTE:** For instructions on how to mount the Display Module to the panel, refer to Installing to the Panel (see page 77).



## Attaching Fixing Bracket (SP-5490WA)

By using the fixing bracket optional part (model number: PFXZCHBMFBS1), you can secure the Box Module to the Display Module.

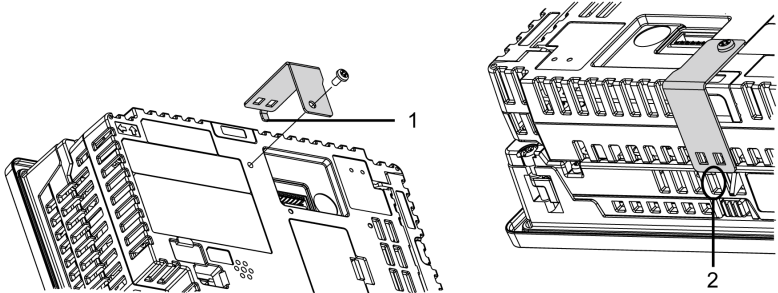
Step	Action
1	<p>Hook the end of the fixing bracket in the ventilation hole at the top of the Display Module, and use a screw (1 piece) to secure the fixing bracket to the back of the Box Module. The necessary torque is 0.5 N•m (4.4 lb-in).</p>  <p>1 Fixing bracket 2 Ventilation hole</p>

### ***NOTICE***

#### **BROKEN ENCLOSURE**

Do not exert more than 0.5 N•m (4.4 lb-in) of torque when tightening the screw.

**Failure to follow these instructions can result in equipment damage.**

**NOTE:** When the fixing bracket is attached, you cannot attach the isolation unit nor the USB/RS-422/485 conversion adapter.

## Attaching Fixing Bracket (SP-5690WA/5790WA)

By using the fixing bracket optional part (model number: PFXZCHBMFBL1), you can secure the Box Module to the Display Module.

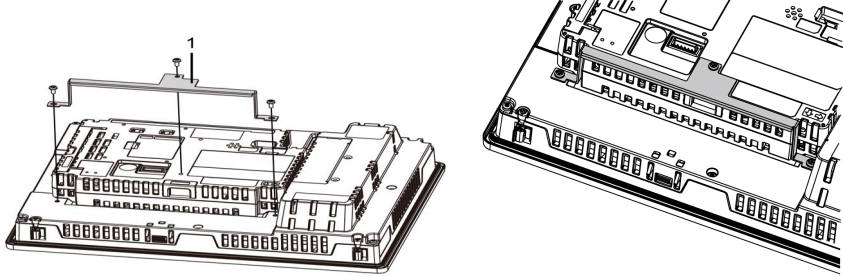
Step	Action
1	<p>Line up the fixing bracket to the back of the Box Module and secure with a screw (1 piece). Also fasten screws to the Display Module in 2 places. The necessary torque is 0.5 N•m (4.4 lb-in).</p>  <p>1 Fixing bracket</p>

### ***NOTICE***

#### **BROKEN ENCLOSURE**

Do not exert more than 0.5 N•m (4.4 lb-in) of torque when tightening the screw.

**Failure to follow these instructions can result in equipment damage.**

**NOTE:** When the fixing bracket is attached, you cannot attach the isolation unit nor the USB/RS-422/485 conversion adapter.

## Removing from Display Module

### DANGER

#### HAZARD OF ELECTRIC SHOCK, EXPLOSION, OR ARC FLASH

- Remove all power from the device before removing any covers or elements of the system, and prior to installing or removing any accessories, hardware, or cables.
- Unplug the power cable from both this product and the power supply prior to installing or removing the product.
- Always use a properly rated voltage sensing device to confirm power is off where and when indicated.
- Replace and secure all covers or elements of the system before applying power to this product.

**Failure to follow these instructions will result in death or serious injury.**

### NOTICE

#### EQUIPMENT DAMAGE

When this product is mounted vertically, first remove the Display Module from the panel, then remove the Box Module from the Display Module.

**Failure to follow these instructions can result in equipment damage.**

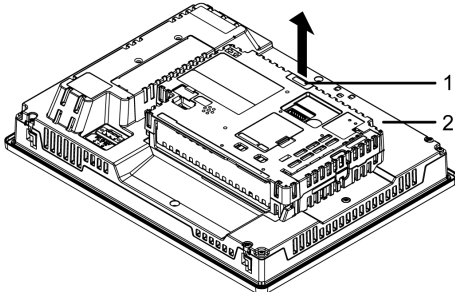
Step	Action
1	When mounting this product vertically, remove the Display Module from the panel and place the Display Module on a clean and level surface with the screen facing down. Refer to Removing from the Panel ( <i>see page 80</i> ).
2	Release the LOCK on the top of the Box Module as illustrated. <div style="text-align: center;">  </div> <p>1 LOCK 2 Display Module</p>

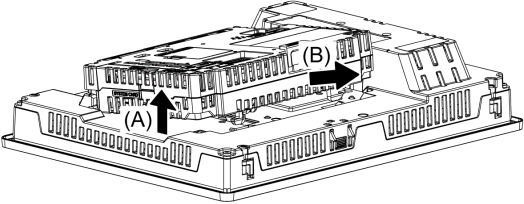
Step	Action
3	<p>Lift the Box Module in the direction indicated by arrow (A) in the diagram and remove it by sliding in the direction indicated by arrow (B).</p> 

**⚠ CAUTION**

**RISK OF INJURY**

- When removing the Box Module from the Display Module, hold the unit in place so it does not drop.
- Use both hands.

**Failure to follow these instructions can result in injury or equipment damage.**

## Installing to the Panel

### **DANGER**

#### HAZARD OF ELECTRIC SHOCK, EXPLOSION, OR ARC FLASH

- Remove all power from the device before removing any covers or elements of the system, and prior to installing or removing any accessories, hardware, or cables.
- Unplug the power cable from both this product and the power supply prior to installing or removing the product.
- Always use a properly rated voltage sensing device to confirm power is off where and when indicated.
- Replace and secure all covers or elements of the system before applying power to this product.

**Failure to follow these instructions will result in death or serious injury.**

### ***NOTICE***

#### EQUIPMENT DAMAGE

- When mounting this product vertically, first install the Box Module onto the Display Module before attaching the Display Module to the panel.
- Keep this product stabilized in the panel-cut while you are installing or removing the screw fasteners.

**Failure to follow these instructions can result in equipment damage.**

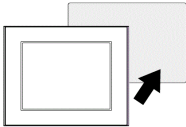
Step	Action
1	When mounting this product vertically, place the Display Module on a clean and level surface with the screen facing down and mount the Box Module to the Display Module. Refer to Installing onto Display Module ( <i>see page 71</i> ).
2	Check that the Display Module's gasket is seated securely into the bezel's groove, which runs around the perimeter of the display panel frame. <b>NOTE:</b> Always use the installation gasket, since it absorbs vibration in addition to repelling water. For the procedure on replacing the installation gasket, refer to Replacing the Installation Gasket ( <i>see page 106</i> ).
3	Based on the Display Module's Panel Cut Dimensions ( <i>see page 70</i> ), open a mount-hole on the panel and attach the Display Module to the panel from the front side. 

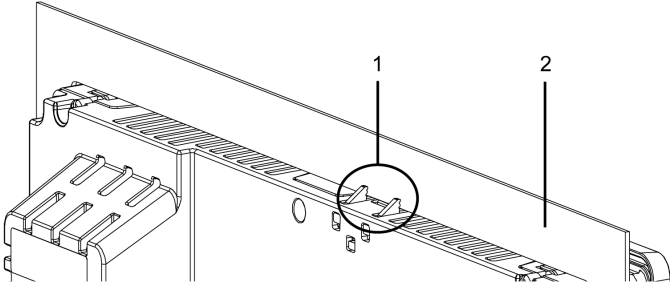
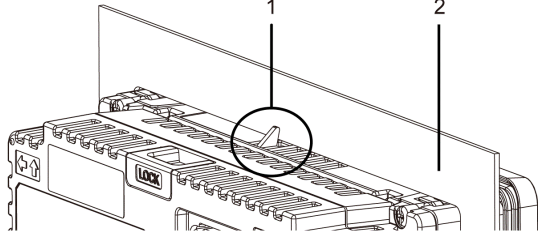
Step	Action
4	<p data-bbox="294 202 1125 231">Confirm that the anti-drop lock on the top of the Display Module is attached to the panel.</p> <p data-bbox="294 255 514 284">Except for SP-5490WA</p>  <p data-bbox="294 637 411 666">SP-5490WA</p>  <p data-bbox="294 938 445 991"><b>1</b> Anti-drop lock <b>2</b> Panel</p>

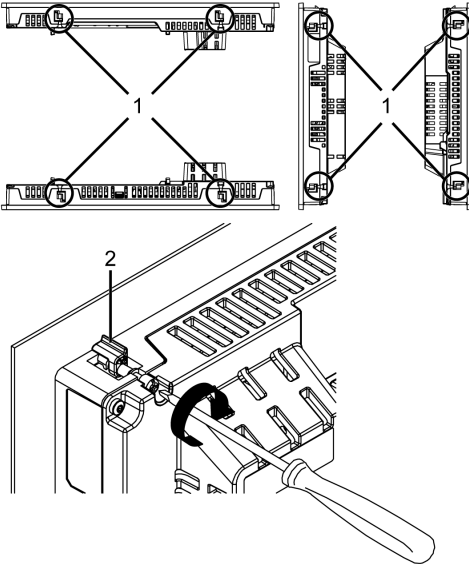
Step	Action
5	<p>Using a Phillips screwdriver, gradually tighten (turn clockwise) the screws for the fasteners (top, bottom, left, and right), alternating diagonally between screws until all are secure. Be sure that the L-shaped part of the installation fastener (2 in figure below) is completely vertical. The necessary torque is 0.7 N•m (6.2 lb-in).</p> <p><b>NOTE:</b></p> <ul style="list-style-type: none"> <li>● If the Display Module is not mounted properly, it may fall.</li> <li>● If the panel is thick (approximately 5 mm [0.2 in]), you may have trouble straightening the L-shaped part of the installation fastener. If this happens, push the display module from the front as you tighten the screws.</li> </ul>  <p>1 Installation fastener 2 L-shaped part of the installation fastener</p> <p><b>Number of Installation Fasteners</b></p> <p>15-inch or larger models:</p> <ul style="list-style-type: none"> <li>● Top - 2, Bottom - 2, Right - 2, Left - 2</li> </ul> <p>Models less than 12-inch:</p> <ul style="list-style-type: none"> <li>● Top - 2, Bottom - 2, Right - None, Left - None</li> </ul>

## ***NOTICE***

### **BROKEN ENCLOSURE**

Do not exert more than 0.7 N•m (6.2 lb-in) of torque when tightening the fastener's screws.

**Failure to follow these instructions can result in equipment damage.**

## Removing from the Panel

### DANGER

#### HAZARD OF ELECTRIC SHOCK, EXPLOSION, OR ARC FLASH

- Remove all power from the device before removing any covers or elements of the system, and prior to installing or removing any accessories, hardware, or cables.
- Unplug the power cable from both this product and the power supply prior to installing or removing the product.
- Always use a properly rated voltage sensing device to confirm power is off where and when indicated.
- Replace and secure all covers or elements of the system before applying power to this product.

**Failure to follow these instructions will result in death or serious injury.**

### NOTICE

#### EQUIPMENT DAMAGE

- When this product is mounted vertically, first remove the Display Module from the panel, then remove the Box Module from the Display Module.
- Keep this product stabilized in the panel cutout while you are installing or removing the screw fasteners.

**Failure to follow these instructions can result in equipment damage.**

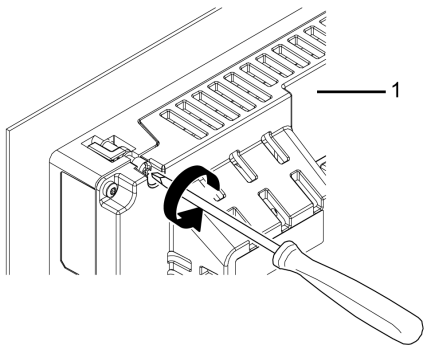
Step	Action
1	<p>Using a Phillips screwdriver, gradually loosen (turn counterclockwise) the screws for the fasteners (top, bottom, left, and right), alternating diagonally between screws until all screws are loose.</p>  <p>1 Rear side</p> <p><b>NOTE:</b></p> <ul style="list-style-type: none"> <li>• For the number of installation fasteners on your model, see Number of Installation Fasteners in Step 5 of Installing to the Panel (<i>see page 77</i>).</li> <li>• If the panel is thick (approximately 5 mm [0.2 in]), you may have trouble straightening the L-shaped part of the installation fastener. If this happens, push the display module from the front as you loosen the screws.</li> </ul>

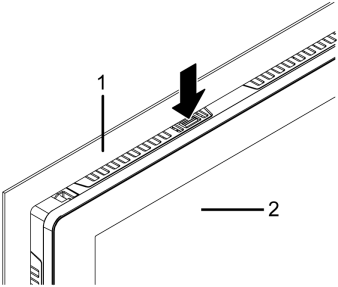

Step	Action
2	<p>While pushing on the anti-drop lock on the top of the Display Module with a tool such as a screwdriver, slowly remove the Display Module from the panel.</p>  <p>1 Panel 2 Front side</p>

## ⚠ CAUTION

### RISK OF INJURY

Do not drop this product when you remove it from the panel.

- Hold this product in place after removing the fasteners.
- Use both hands.
- While pushing on the anti-drop lock, be careful not to hurt your fingers.

**Failure to follow these instructions can result in injury or equipment damage.**

## *NOTICE*

### EQUIPMENT DAMAGE

To avoid damage, remove this product while pushing the anti-drop lock or by making sure the lock does not touch the panel.

**Failure to follow these instructions can result in equipment damage.**

# Section 6.2

## Wiring Principles

---

### What Is in This Section?

This section contains the following topics:

Topic	Page
Connecting the DC Power Cord	83
Connecting the Power Supply	86
Grounding	88

## Connecting the DC Power Cord

### **DANGER**

#### **HAZARD OF ELECTRIC SHOCK, EXPLOSION, OR ARC FLASH**

- Remove all power from the device before removing any covers or elements of the system, and prior to installing or removing any accessories, hardware, or cables.
- Remove power before wiring this product's power terminals.
- Always use a properly rated voltage sensing device to confirm power is off where and when indicated.
- Replace and secure all covers or elements of the system before applying power to this product.
- Use only the specified voltage when operating this product. This product is designed to use 12 to 24 Vdc power. Always check whether your device is DC powered before applying power.
- Since this product is not equipped with a power switch, be sure to connect a power switch to the power supply.
- Be sure to ground this product's FG terminal.

**Failure to follow these instructions will result in death or serious injury.**

#### **NOTE:**

- The SG (signal ground) and FG (functional ground) terminals are connected internally in this product.
- When the FG terminal is connected, be sure the wire is grounded. Not grounding this product can result in excessive electromagnetic interference (EMI).

### DC Power Cord Preparation

- Make sure the ground wire is either the same or heavier gauge than the power wires.
- Do not use aluminum wires in the power supply's power cord.
- To prevent the possibility of a terminal short, use a pin terminal that has an insulating sleeve.
- If the ends of the individual wires are not twisted correctly, the wires may create a short circuit.
- The conductor type is solid or stranded wire.
- Use copper wire rated for 75 °C (167 °F) or higher.

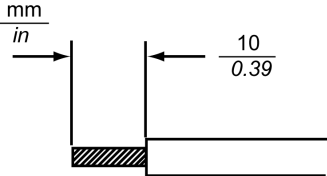
Power Cord Diameter	0.75...2.5 mm <sup>2</sup> (18...13 AWG) <sup>*1</sup>
Conductor type	Solid or stranded wire
Conductor length	
Recommended Driver <sup>*2</sup>	SZS 0.6x3.5 (1205053)
Recommended Pin Terminals <sup>*2</sup>	3201288 AI 0,75-10 GY 3200182 AI 1 -10 RD 3200195 AI 1,5 -10 BK 3202533 AI 2,5 -10 BU
Recommended Pin Terminal Crimp Tool <sup>*2</sup>	CRIMPFOX 6

\*1 For UL compatibility, use AWG 14 or AWG 13.

\*2 Items are manufactured by Phoenix Contact.

### DC Power Supply Connector Specifications: Spring Clamp Terminal Blocks

Models except for SP-5490WA come with the right-angle-type power connector, and the SP-5490WA comes with the straight-type power connector.

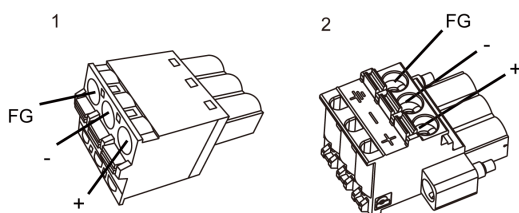

1 Straight type: PFXZCBCNDC1 by Pro-face

2 Right-angle type: PFXZCHCND3 by Pro-face

**NOTE:** You cannot connect the right-angle type to the SP-5490WA.

Connection	Wire
+	12...24 Vdc
-	0 Vdc
FG	Grounded terminal connected to the panel chassis.

### How to connect the DC Power Cord

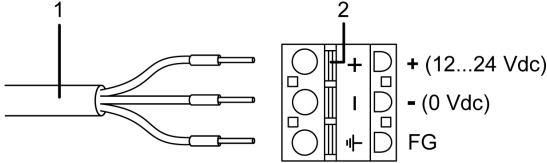
Step	Action
1	Confirm the power cord is not connected to the power supply.
2	Check the rated voltage and remove the “DC24V” sticker on the DC power supply connector.
3	Connect each wire from the power cable to a pin terminal.
4	Push the Opening button with a small and flat screwdriver to open the desired pin hole.
5	<p>Insert each power cord wire into its corresponding hole. Release the Opening button to clamp the wire in place.</p>  <p>1 Power cord 2 Opening button When using stranded wire, do not short with neighboring wires.</p>
6	After inserting all three power cord wires, insert the DC power supply connector into the power connector on this product.
7	When using the DC power connector with fixable screws, use a slot-head screwdriver to affix the screws on both sides of the connector. The necessary torque is 0.5 N•m (4.4 lb-in).

**NOTE:**

- Do not solder the wire directly to the power crimp pin.
- If the wire is not inserted into the FG terminal properly, touch may not respond normally.

## Connecting the Power Supply

### Precautions

DANGER

**SHORT CIRCUIT, FIRE, OR UNINTENDED EQUIPMENT OPERATION**

Avoid excessive force on the power cable to prevent accidental disconnection

- Securely attach power cables to an installation panel or cabinet.
- Install and fasten this product on installation panel or cabinet prior to connecting power supply and communication lines.

**Failure to follow these instructions will result in death or serious injury.**

### Improving Noise/Surge Resistance

- This product's power supply cord should not be bundled with or kept close to main circuit lines (high voltage, high current), power lines, or input/output lines, and their various systems should be kept separate. When power lines cannot be wired via a separate system, use shielded cables for input/output lines.
- Make the power cord as short as possible, and be sure to twist the ends of the wires together (i.e. twisted pair cabling) from close to the power supply unit.
- If there is an excess amount of noise on the power supply line, reduce the noise with a noise filter before turning on the power.
- Connect a surge protection device to handle power surges.
- To increase noise resistance, attach a ferrite core to the power cable.

### Power Supply Connections

- When supplying power to this product, connect the power as shown below.

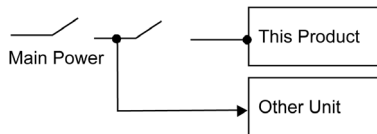

- Use SELV (Safety Extra-Low Voltage) circuit and LIM (Limited Energy) circuit for DC input.
- The following shows a surge protection device connection:

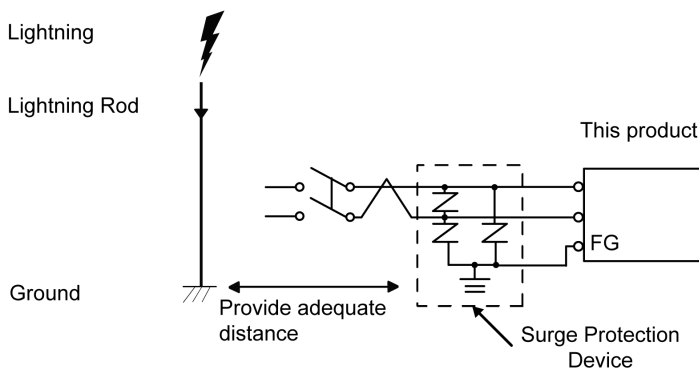

- Attach a surge protection device to prevent damage to this product as a result of a lightning-induced power surge from a large electromagnetic field generated from a direct lightning strike. We also strongly recommend to connect the crossover grounding wire of this product to a position close to the ground terminal of the surge protection device. It is expected that there will be an effect on this product due to fluctuations in grounding potential when there is a large surge flow of electrical energy to the lightning rod ground at the time of a lightning strike. Provide adequate distance between the lightning rod grounding point and the surge protection device grounding point.
- If the voltage variation is outside the prescribed range, connect a regulated power supply.

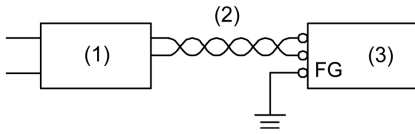

- 1 Regulated power supply
- 2 Twisted-pair cord
- 3 This product

## Grounding

### Exclusive Grounding

Always ground the FG (functional ground) terminal. Be sure to separate this product from the FG of other devices as shown below.

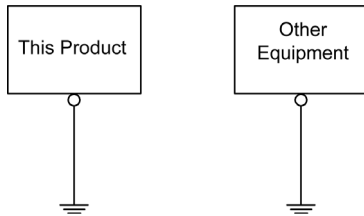

### Precautions

- Check that the grounding resistance is 100  $\Omega$  or less.\*1
- The FG wire should have a cross sectional area greater than 2 mm<sup>2</sup> (AWG14)\*1. Create the connection point as close to this product as possible, and make the wire as short as possible. When using a long grounding wire, replace the thin wire with a thicker wire, and place it in a duct.
- The SG (signal ground) and FG (functional ground) terminals are connected internally in this product. When connecting the SG line to another device, be sure that no ground loop is formed.

\*1 Observe local codes and standards.

### Common Grounding

Electromagnetic Interference (EMI) can be created if devices are improperly grounded. EMI can cause loss of communication. If exclusive grounding is not possible, use a common grounding point as shown in the configuration below. Do not use any other configuration for common grounding.

Correct grounding

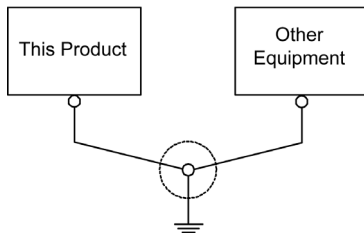

Incorrect grounding

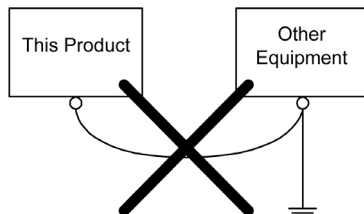



---

## Section 6.3

### USB Cable Clamp

---

#### What Is in This Section?

This section contains the following topics:

Topic	Page
USB Clamp Type A (1 port)	90
USB Clamp mini-B (1 port)	92

## USB Clamp Type A (1 port)

### Introduction

When using a USB device, attach a USB cable clamp to the USB interface to prevent the USB cable from being disconnected.

DANGER

**POTENTIAL FOR EXPLOSION**

- Verify the power, input, and output (I/O) wiring are in accordance with Class I, Division 2 wiring methods.
- Substitution of any components may impair suitability for Class I, Division 2.
- Do not disconnect equipment while the circuit is live or unless the area is known to be free of ignitable concentrations.
- Remove power before attaching or detaching any connectors to or from this product.
- Ensure that power, communication, and accessory connections do not place excessive stress on the ports. Consider the vibration in the environment when making this determination.
- Securely attach power, communication, and external accessory cables to the panel or cabinet.
- Use only commercially available USB cables.
- Use only non-incendive USB configurations.
- Suitable for use in Class I, Division 2, Groups A, B, C, D Hazardous Locations.
- Confirm that the USB cable has been attached with the USB cable clamp before using the USB interface.

**Failure to follow these instructions will result in death or serious injury.**

### Attaching USB Clamp Type A (1 port)

**NOTE:** Watch your fingers. The edge of the clip is sharp.

Step	Action
1	<p>Mount the clip to the USB mark  connector shell so that it overlaps. The clip matches the 27 to 43.5 mm (1.06 to 1.71 in) length of the USB connector.</p> <div style="text-align: center;"> </div> <p><b>NOTE:</b> When installing clamps to reduce cable stress onto both USB1 and USB2, at USB1 overlay the clip on the side with the USB mark, and on USB2 the side without the USB mark. Make sure the ties do not interfere with the other.</p>

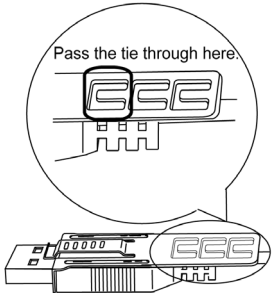
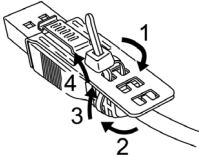
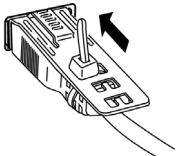
Step	Action
2	<p>Align the clip and the USB cable connector shell. Adjust the position of the holes where the clip is attached. To ensure stability, select the clip-hole position that is closest to the base of the connector shell.</p> 
3	<p>As shown, pass the tie through the clip hole. Next, turn the tie and pass it through the head so that the USB cable can pass through the center of the tie loop. The clip is now attached to the USB cable.</p>  <p><b>NOTE:</b></p> <ul style="list-style-type: none"> <li>• Check the direction of the head beforehand. Make sure the USB cable is through the center of the tie loop and that the tie can pass through the head.</li> <li>• You can substitute the tie provided with PFXZCBCLUSA1 (by Schneider Electric), or other commercially available ties with a width of 4.8 mm (0.19 in) and thickness of 1.3 mm (0.05 in).</li> </ul>
4	<p>While pressing the grip on the clip, insert the cable from step 3 all the way into the USB host interface. Make sure that the clip tab is secured to the USB cable attached to this product.</p> 

### Removing USB Cable Clamp Type A (1 port)

Remove the USB cable while pushing the grip section of the clip.

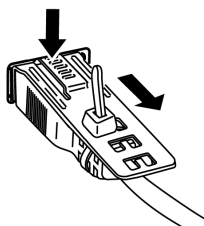

## USB Clamp mini-B (1 port)

### Introduction

When using a USB device, you can attach the Pro-face USB Clamp mini-B (model number: ZC9USCLMB1), a USB cable clamp to prevent disconnection from the USB port.

# ⚠ DANGER

**POTENTIAL FOR EXPLOSION**

- Verify the power, input, and output (I/O) wiring are in accordance with Class I, Division 2 wiring methods.
- Substitution of any components may impair suitability for Class I, Division 2.
- Confirm that the USB cable has been fixed with the USB clamp before using the USB interface.
- Remove power before attaching or detaching any connectors to or from this product.
- Use the USB (mini-B) interface for temporary connection only during maintenance and setup of the device.
- Do not use the USB (mini-B) interface in hazardous locations.

**Failure to follow these instructions will result in death or serious injury.**

### Attaching the USB Clamp

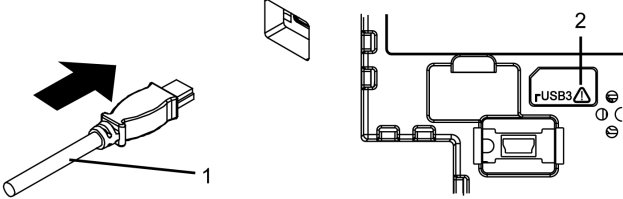
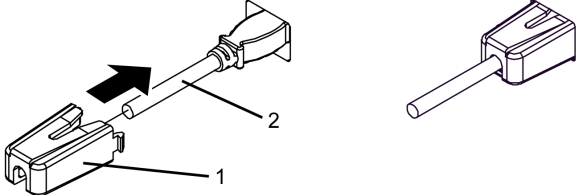
Step	Action
1	<p>Insert the USB cable into the USB (mini-B) interface.</p>  <p>1 USB cable 2 This mark identifies safety messages about the USB Clamp mini-B (1 port)</p>
2	<p>Attach the USB clamp to fix the USB cable in place. Insert the USB holder into the USB (mini-B) interface.</p>  <p>1 USB clamp 2 USB cable</p>

### Removing the USB Clamp

Remove the USB clamp by pressing the tabs from the sides.

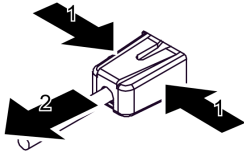

# Section 6.4

## AUX Connector

### Introduction

DANGER

**HAZARD OF ELECTRIC SHOCK, EXPLOSION, OR ARC FLASH**

- Remove the AUX connector from this product prior to wiring.
- Strip wires only to the required length.
- Do not solder the wire itself.

**Failure to follow these instructions will result in death or serious injury.**

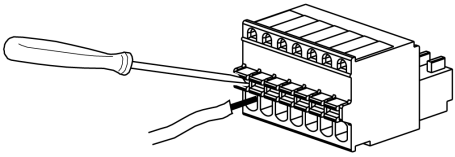
Step	Action
1	Align the flat-head screwdriver with the groove of the orange spring release button, and while depressing the button insert the electric wire into the wire insertion slot (round-shaped hole).
2	<p>Pull out the screwdriver from the release button. The wire insertion slot is then closed and the wire is held securely in place. To remove the wire, align the flat-head screwdriver with the groove of the release button, and while depressing the button pull the wire out.</p> <div style="text-align: center;">  </div>
3	Insert the wired AUX connector into the Auxiliary Output/Speaker Output Interface (AUX) of this product.

**Recommendations:**

- AUX Connector: PFXZCDCNAUX1 by Schneider Electric
  - Screwdriver: SZS 0.4 X 2.0 (Product No. 1205202) by Phoenix Contact
- If you use another manufacturer, be sure the part has the following dimensions:
- Blade thickness: 0.4 mm (0.02 in)
  - Blade width: 2.0 mm (0.08 in)
- Point shape should have isolation properties meeting DIN 5264 and EN60900.

**NOTE:**

- Wire should be AWG 28 to AWG 20 thick and twisted.
- Applicable wire sizes are Style 1015 and Style 1007.
- Be sure to strip 8.0 mm (0.31 in) of cover from the wire.
- Use copper wire rated for 75 °C (167 °F) or higher.

---

## Section 6.5

### SD Card Insertion/Removal

---

#### What Is in This Section?

This section contains the following topics:

Topic	Page
Introduction	96
Inserting the SD Card	97
Removing the SD Card	98

## Introduction

### ***NOTICE***

#### **LOSS OF DATA**

When using a SD Card:

- Make sure you regularly back up the SD Card data.
- While a SD Card is accessed, do not turn OFF or reset this product, and do not remove the SD Card.
- Before removing the SD Card from this product, stop all operations on the SD Card.
- Make sure of the SD Card's orientation before inserting it into the SD Card slot.

**Failure to follow these instructions can result in equipment damage.**

### ***NOTICE***

#### **LOSS OF DATA**

When handling the SD Card:

- Avoid storing the SD Card where there is static electricity or electromagnetic waves.
- Avoid storing the SD Card in direct sunlight, near a heater, or other locations where high temperatures can occur.
- Do not bend the SD Card.
- Do not drop or strike the SD Card against another object.
- Keep the SD Card dry.
- Do not touch the SD Card connectors.
- Do not disassemble or modify the SD Card.
- Use the SD Card initialized by this product. You may not be able to use the SD Card initialized by other devices.

**Failure to follow these instructions can result in equipment damage.**

**NOTE:** To make your backups, you can either insert the SD Card directly into the SD Card Slot on your computer, or use a commercially available SD Card reader.



## Inserting the SD Card

**NOTE:** As shown in the image below (example on the left-hand side), you can set the Write-Control Tab to prevent write operations to the SD Card. Push the tab up, as shown in the example on the right-hand side, to release the lock and enable writing to the SD Card. Before using a commercial-type SD Card, read the manufacturer's instructions.

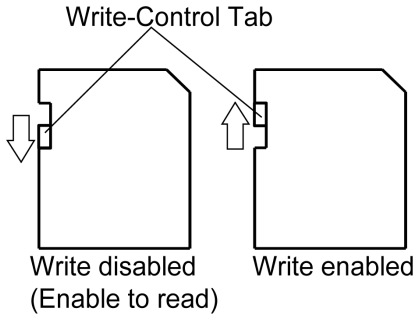

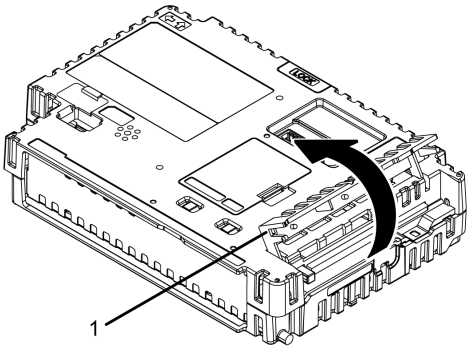
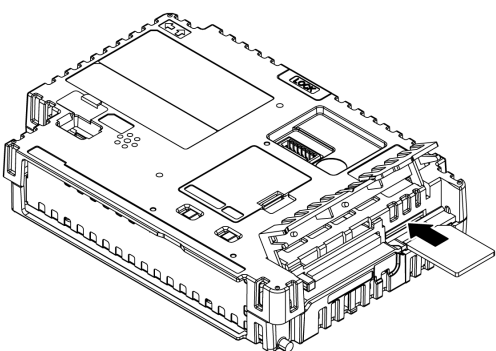
Step	Action
1	<p>Open the Storage Card Cover.</p>  <p>1 Storage card cover</p>
2	<p>Insert the SD Card into the SD Card Slot with the front face of the SD Card facing up and push until you hear it "click".</p> 
3	<p>Close the Storage Card Cover.</p>

## Removing the SD Card

If you remove the SD Card while it is in use, you risk corrupting your data. Before removing the SD Card from this product, stop all operations on the SD Card.

For instructions on removing the SD Card safely, refer to the corresponding topic in the manual of your screen editing software.

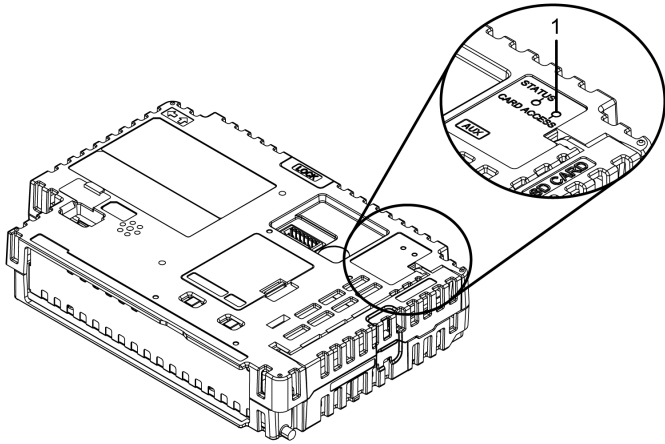
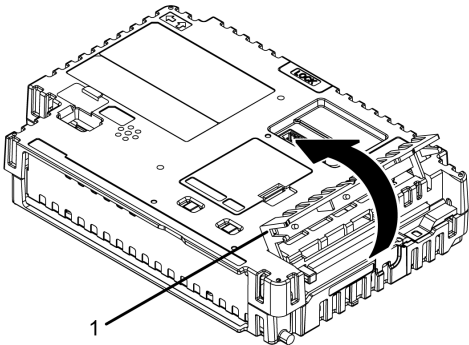
Step	Action
1	<p>Make sure the Card Access LED is off.</p>  <p>1 Card access LED</p>
2	<p>Open the Storage Card Cover.</p>  <p>1 Storage card cover</p>
3	<p>Push the SD Card once to release, and pull out the card.</p> <p><b>NOTE:</b> After using the SD Card, store the SD Card in its case or other safe location.</p>
4	<p>Close the Storage Card Cover.</p>

---

# Section 6.6

## Isolation Unit and USB/RS-422/485 Conversion Adapter

---

### What Is in This Section?

This section contains the following topics:

Topic	Page
Introduction	100
Installing to the Box Module	101

## Introduction

**NOTE:** For details such as settings when using the Isolation Unit or USB/RS-422/485 Conversion Adapter, refer to the product manual.

  **DANGER**

**HAZARD OF ELECTRIC SHOCK OR EXPLOSION**

To avoid an electric shock, prior to connecting the Isolation Unit or USB/RS-422/485 Conversion Adapter to this product, confirm that this product's power supply is completely turned OFF.



**Failure to follow these instructions will result in death or serious injury.**

## Installing to the Box Module

You can install the Isolation Unit or USB/RS-422/485 Conversion Adapter to the back of the Box Module or to the installation panel. For more information on how to attach the Isolation Unit or USB/RS-422/485 Conversion Adapter to the installation panel, please refer to the product installation guide.

**NOTE:**

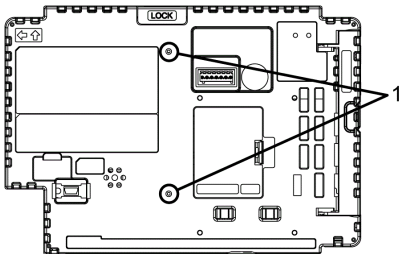
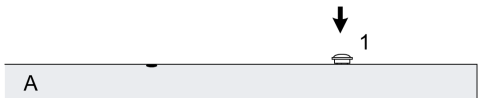
- Installing the USB/RS-422/485 Conversion Adapter to the Box Module is the same as the following procedures.
- When the fixing bracket is attached, you cannot attach the isolation unit nor the USB/RS-422/485 conversion adapter.

Step	Action
1	<p>Check the locations of two screw holes on the front of the Box Module.</p>  <p>1 Screw hole</p>
2	<p>Install one of the two attachment screws included in the Isolation Unit to the Box Module. Use a torque of 0.5 N•m (4.4 lb-in).</p>  <p>1 Attachment screw A Box Module</p>
3	<p>Attach the Isolation Unit to the Box Module.</p>  <p>2 Isolation Unit A Box Module</p>

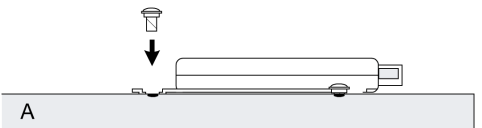
Step	Action
4	<p>Slide the Isolation Unit in the direction of the arrow so the Isolation Unit is hooked by the screw from Step 2.</p>  <p>A Box Module</p>
5	<p>Secure the Isolation Unit in place with another attachment screw. Use a torque of 0.5 N•m (4.4 lb-in).</p>  <p>A Box Module</p>

**NOTE:**

- Attach the Isolation Unit to a stable surface. Do not leave the Isolation Unit or USB/RS-422/485 Conversion Adapter hanging by its cord.
- Be careful with wire placement. Overlapping cords may cause noise.
- When attaching the Isolation Unit or USB/RS-422/485 Conversion Adapter to the Box Module, be careful with the attachment position.
- See the illustration below for recommended installation.

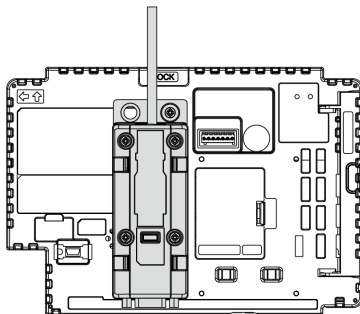

---

# Chapter 7

## Maintenance

---

### What Is in This Chapter?

This chapter contains the following topics:

Topic	Page
Regular Cleaning	104
Periodic Check Points	105
Replacing the Installation Gasket	106
Replacing the Primary Battery	107
Replacing the System Card (SD Card)	110
Replacing the Backlight	112
After-sales Service	113

## Regular Cleaning

### Cleaning this product

<b><i>NOTICE</i></b>
----------------------

<b>EQUIPMENT DAMAGE</b>
-------------------------

- |  |
|--|
| <ul style="list-style-type: none"><li>● Power off this product before cleaning it.</li><li>● Do not use hard or pointed objects to operate the touch panel.</li><li>● Do not use paint thinner, organic solvents, or a strong acid compound to clean the unit.</li></ul> |
|--|

<b>Failure to follow these instructions can result in equipment damage.</b>
---

When this product gets dirty, soak a soft cloth in water with a neutral detergent, wring the cloth tightly and wipe this product.



## Periodic Check Points

### Operation Environment

- Is the ambient air temperature within the allowable range? Refer to Environmental Specifications (*see page 38*).
- Is the ambient air humidity within the specified range? Refer to Environmental Specifications (*see page 38*).

When this product is inside a panel, the ambient environment refers to the interior of the panel.

### Electrical Specifications

- Is the input voltage appropriate? Refer to Electrical Specifications (*see page 37*).
- Are all power cords and cables connected properly? Are there any loose cables?
- Are all mounting brackets holding the unit securely?
- Are there scratches or traces of dirt on the installation gasket?

### Unit Disposal

When disposing this product, dispose it in a manner appropriate to, and in accordance with, your country's industrial machinery disposal/recycling standards.

## Replacing the Installation Gasket

### Introduction

The installation gasket provides protection against dust and moisture.

### ***NOTICE***

#### **GASKET AGING**

- Inspect the gasket periodically as required by your operating environment.
- Change the gasket at least once a year, or as soon as scratches or dirt become visible.

**Failure to follow these instructions can result in equipment damage.**

### Installing the Installation Gasket

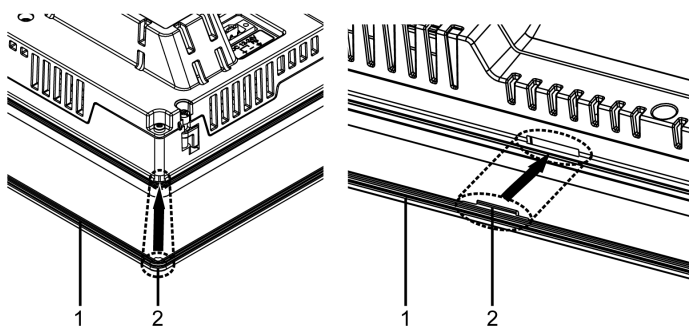
Stage	Description
1	Place the Display Module on a flat, level surface, with the display face pointing down.
2	Remove the gasket from the Display Module.
3	<p>Attach the new gasket to the Display Module. Insert the protrusions from the four corners of the gasket into the corresponding holes in the corners of the Display Module. Depending on your model, there may be additional protrusions. In the following, refer to the figure on the right and insert the protrusions accordingly.</p> <p><b>NOTE:</b> When using a tool to insert the gasket, make sure the tool does not catch the rubber gasket and cause a tear.</p> <div style="text-align: center;">  </div> <p>1 Installation gasket 2 Protruding point</p>

The gasket must be inserted correctly into the groove for moisture resistance for the Display Module.

### ***NOTICE***

#### **EQUIPMENT DAMAGE**

Be careful not to stretch the gasket unnecessarily.

**Failure to follow these instructions can result in equipment damage.**

## Replacing the Primary Battery

### Introduction

Backup clock data uses a Supercapacitor (electric double-layer capacitor) for power. When the voltage from the Supercapacitor is low, clock data is lost\*<sup>1</sup> when this product is turned OFF. The average period for backup is as follows:

Initial: approximately 100 days

After 5 years: approximately 30 days (when used with an ambient temperature of 25 °C [77 °F])

\*1 If clock data is lost, a clock data error message appears when starting up this product. When this happens, please set up the clock again. Refer to your screen editing software manual on how to set up the clock.

By connecting the optional backup battery (model number: PFXZCBBT1) for clock data backup, you can maintain a backup period of up to 5 years or more (when used with an ambient temperature of 25 °C [77 °F]). However, as the battery expires after 5 years, we recommend regularly changing the battery every 5 years.

#### NOTE:

- Because the battery for clock data backup is a lithium battery, its performance degrades based on the temperature. As a result, when the battery's ambient temperature is higher, the backup period is shorter.

When the voltage of the Supercapacitor drops at the same time as the voltage in the battery, clock data is lost when power is disconnected. If the clock data error message appears while the battery is connected, the battery is low and requires replacement.

### DANGER

#### HAZARD OF ELECTRIC SHOCK, EXPLOSION, OR ARC FLASH

- Remove all power from the device before removing any covers or elements of the system, and prior to installing or removing any accessories, hardware, or cables.
- Unplug the power cable from both this product and the power supply prior to installing or removing the product.
- Always use a properly rated voltage sensing device to confirm power is off where and when indicated.
- Replace and secure all covers or elements of the system before applying power to this product.
- Use only the specified voltage when operating this product. This product is designed to use 12 to 24 Vdc. Always check whether your device is DC powered before applying power.

**Failure to follow these instructions will result in death or serious injury.**

### DANGER

#### EXPLOSION, FIRE, OR CHEMICAL HAZARD

- Use only the identical replacement battery for this product.
- Do not cause a short circuit.
- Recycle or properly dispose of used batteries.

**Failure to follow these instructions will result in death or serious injury.**

## ***NOTICE***

### **LOSS OF DATA**

- Before replacing the battery, supply power to this product for 5 minutes or more.
- Replace the battery regularly every five years after you purchase this product.
- Allow only qualified personnel to change the battery.

**Failure to follow these instructions can result in equipment damage.**

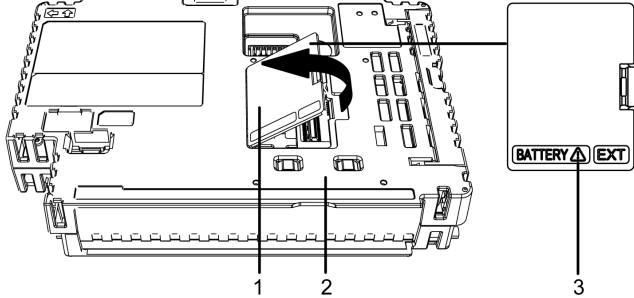
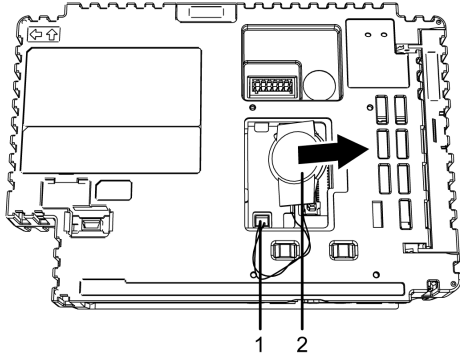
Step	Action
1	Disconnect the power supply from this product.
2	Touch the housing or ground connection to discharge any electrostatic charge from your body.
3	Place the Box Module on a flat, level surface, with the front side pointing up.
4	<p>Open the Expansion Unit Interface Cover on the Box Module.</p>  <p>1 Expansion Unit Interface Cover                  2 Box Module                  3 Safety alert symbol (see the safety messages stated in this topic)</p>
5	<p>If the battery is already installed, slide the battery in the direction of the arrow as illustrated. Unplug the cable from the connector.</p>  <p>1 Connector                  2 Battery</p>

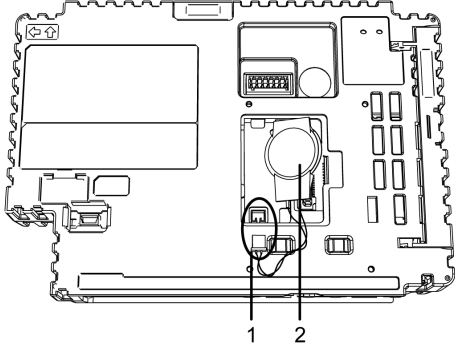
Step	Action
6	<p data-bbox="351 204 1215 253">Insert a new battery and the connector all the way. Either side of the battery can face top or bottom.</p>  <p data-bbox="351 649 467 697">1 Connector 2 Battery</p>
7	<p data-bbox="351 712 749 736">Close the Expansion Unit Interface Cover.</p> <p data-bbox="351 751 1222 799"><b>NOTE:</b> Make sure the cable is inserted completely inside the enclosure. Otherwise, you can damage the cable when you close the cover.</p>
8	<p data-bbox="351 817 762 840">Reconnect the power supply to this product.</p> <p data-bbox="351 855 1195 904"><b>NOTE:</b> After reconnecting the power supply, set up the clock again. Refer to your screen editing software manual on how to set up the clock.</p>

## Replacing the System Card (SD Card)

The System Card is an SD Card with the operating system installed on it.

To replace the System Card, use a SD Card by Pro-face. Refer to Accessories (*see page 24*).

### ***NOTICE***

#### **LOSS OF DATA**

When using a SD Card:

- Make sure you regularly back up the SD Card data.
- While a SD Card is accessed, do not turn OFF or reset this product, and do not remove the SD Card.
- Before removing the SD Card from this product, stop all operations on the SD Card.
- Make sure of the SD Card's orientation before inserting it into the SD Card slot.

**Failure to follow these instructions can result in equipment damage.**

**NOTE:** For information on backing up your SD card, used as a system card, refer to our support site at <http://www.pro-face.com/trans/en/manual/1001.html>.

### ***NOTICE***

#### **LOSS OF DATA**

When handling the SD Card:

- Avoid storing the SD Card where there is static electricity or electromagnetic waves.
- Avoid storing the SD Card in direct sunlight, near a heater, or other locations where high temperatures can occur.
- Do not bend the SD Card.
- Do not drop or strike the SD Card against another object.
- Keep the SD Card dry.
- Do not touch the SD Card connectors.
- Do not disassemble or modify the SD Card.

**Failure to follow these instructions can result in equipment damage.**

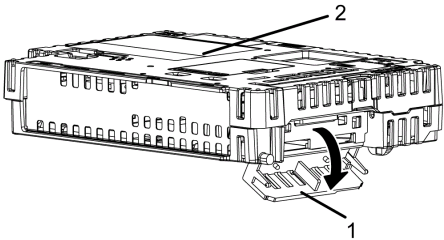
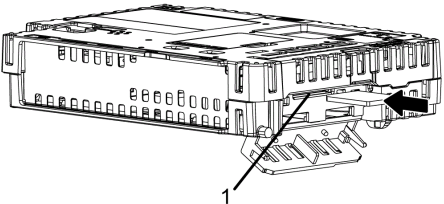
Step	Action
1	Turn OFF this product.
2	Remove the Box Module from the Display Module. <b>NOTE:</b> Refer to Installation ( <i>see page 66</i> ).
3	As illustrated, open the System Card Cover in the direction of the arrow.  <b>1</b> System Card Cover <b>2</b> Box Module
4	Push the SD Card once to release, and pull out the card. <b>NOTE:</b> After using the SD Card, store the SD Card in its case or other safe location.
5	Insert the SD Card into the System Card Slot with the front face of the SD Card facing down, and push until you hear it “click”.  <b>1</b> System Card Slot
6	Close the System Card Cover.
7	Mount the Box Module on the Display Module.

**NOTE:** As shown in the image below (example on the left-hand side), you can set the Write-Control Tab to prevent write operations to the SD Card. Push the tab up, as shown in the example on the right-hand side, to release the lock and enable writing to the SD Card.

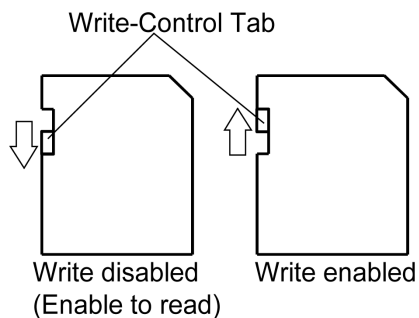

## Replacing the Backlight

Not user replaceable. When replacement is required, contact customer support.



## After-sales Service

### Information

For details on after-sales service, refer to our website at

<http://www.pro-face.com/trans/en/manual/1001.html>