

# Modicon M172 Logic Controller Hardware Guide

(Original Document)

09/2018



---

The information provided in this documentation contains general descriptions and/or technical characteristics of the performance of the products contained herein. This documentation is not intended as a substitute for and is not to be used for determining suitability or reliability of these products for specific user applications. It is the duty of any such user or integrator to perform the appropriate and complete risk analysis, evaluation and testing of the products with respect to the relevant specific application or use thereof. Neither Schneider Electric nor any of its affiliates or subsidiaries shall be responsible or liable for misuse of the information contained herein. If you have any suggestions for improvements or amendments or have found errors in this publication, please notify us.

You agree not to reproduce, other than for your own personal, noncommercial use, all or part of this document on any medium whatsoever without permission of Schneider Electric, given in writing. You also agree not to establish any hypertext links to this document or its content. Schneider Electric does not grant any right or license for the personal and noncommercial use of the document or its content, except for a non-exclusive license to consult it on an "as is" basis, at your own risk. All other rights are reserved.

All pertinent state, regional, and local safety regulations must be observed when installing and using this product. For reasons of safety and to help ensure compliance with documented system data, only the manufacturer should perform repairs to components.

When devices are used for applications with technical safety requirements, the relevant instructions must be followed.

Failure to use Schneider Electric software or approved software with our hardware products may result in injury, harm, or improper operating results.

Failure to observe this information can result in injury or equipment damage.

© 2018 Schneider Electric. All Rights Reserved.

# Table of Contents



	<b>Safety Information</b> .....	7
	<b>About the Book</b> .....	9
<b>Part I</b>	<b>Overview</b> .....	13
<b>Chapter 1</b>	<b>M172 Range Overview</b> .....	15
	Modicon M172 Logic Controller Offer Overview .....	16
	Controller Range Overview .....	17
	Expansion Modules Range Overview .....	19
	Communication Modules Range Overview .....	20
	Remote Display Range Overview .....	21
	Accessories .....	23
<b>Part II</b>	<b>Global Features</b> .....	25
<b>Chapter 2</b>	<b>Before Starting</b> .....	27
	Before Starting .....	27
<b>Chapter 3</b>	<b>Wiring Best Practices</b> .....	29
	Wiring Best Practices .....	29
<b>Chapter 4</b>	<b>Installation</b> .....	35
	TM172•••07• / TM172•••18• Controllers Mounting Positions .....	36
	TM172•••28•• / TM172•••42•• Controllers Mounting Positions .....	37
	TM172E••R Expansion Modules Mounting Positions .....	38
	Controllers and Expansion Modules Clearances .....	39
	Top Hat Section Rail (DIN Rail) .....	40
	Controllers and Expansion Modules Installation .....	43
	TM172DCLWT•• Remote Display Installation .....	45
	TM172DCLF• Remote Display Installation .....	46
<b>Part III</b>	<b>Controllers and Expansion Modules</b> .....	49
<b>Chapter 5</b>	<b>Environmental Characteristics</b> .....	51
	Environmental Characteristics .....	51
<b>Chapter 6</b>	<b>TM172P•••••• / TM172O•••••• Controllers Description</b> .....	53
	TM172P•G07R .....	54
	TM172P••18• / TM172O••18• .....	56
	TM172P••28•• / TM172O••28R .....	59
	TM172P••42•• / TM172O••42R .....	62
<b>Chapter 7</b>	<b>TM172E••R Expansion Modules Description</b> .....	65
	TM172E12R .....	66
	TM172E28R .....	68
<b>Chapter 8</b>	<b>Electrical Characteristics and Wiring Diagrams</b> .....	71
8.1	Power Supply .....	73
	Power Supply .....	73
8.2	Digital Input .....	76
	Fast Digital Inputs .....	77
	Regular Digital Inputs .....	78
8.3	Digital Output .....	80
	High voltage Relay SPST Digital Output .....	81
	High Voltage Solid-State Relay Digital Output .....	83
	High voltage Relay SPDT Digital Output .....	84

8.4	Analog Inputs . . . . .	86
	Analog Inputs . . . . .	87
	NTC Analog Input . . . . .	91
	Resistive Analog Input . . . . .	92
	Current Analog Input . . . . .	94
	Voltage Analog Input . . . . .	95
	Analog Input Used as Digital Input . . . . .	96
8.5	Analog Outputs . . . . .	97
	Analog Outputs . . . . .	98
	PWM Open Collector Outputs . . . . .	99
	Low Voltage (SELV) Analog Outputs . . . . .	100
	Analog Current Output . . . . .	101
	Current ON/OFF Current Output . . . . .	102
8.6	Communication . . . . .	103
	CAN Expansion Bus Port . . . . .	104
	RS-485 Serial Ports . . . . .	107
	USB Serial Ports . . . . .	109
	Ethernet Port . . . . .	110
8.7	Memory . . . . .	113
	Memory . . . . .	113
8.8	RTC (Real-Time Clock) . . . . .	115
	RTC (Real-Time Clock) . . . . .	115
<b>Chapter 9</b>	<b>User Interface . . . . .</b>	<b>117</b>
	TM172PD**** / TM172OD**** User Interface . . . . .	117
<b>Part IV</b>	<b>Remote Display . . . . .</b>	<b>119</b>
<b>Chapter 10</b>	<b>Environmental Characteristics . . . . .</b>	<b>121</b>
	Environmental Characteristics . . . . .	121
<b>Chapter 11</b>	<b>TM172DCL**** Remote Display Description . . . . .</b>	<b>123</b>
	TM172DCLWT** . . . . .	124
	TM172DCLF* . . . . .	125
<b>Chapter 12</b>	<b>Electrical Characteristics and Wiring Diagrams . . . . .</b>	<b>127</b>
	Power Supply . . . . .	128
	Embedded Sensors . . . . .	129
	RS-485 Modbus Serial Port . . . . .	130
<b>Part V</b>	<b>Parameters . . . . .</b>	<b>131</b>
<b>Chapter 13</b>	<b>Parameters . . . . .</b>	<b>133</b>
	Overview . . . . .	134
	Controller Parameter Table . . . . .	136
	Expansion Module Parameters Table . . . . .	150
	Display Color Touchscreen Parameters Table . . . . .	158
<b>Part VI</b>	<b>Commissioning . . . . .</b>	<b>161</b>
<b>Chapter 14</b>	<b>EcoStruxure Machine Expert - HVAC software (TM171SW) . . . . .</b>	<b>163</b>
	General Description . . . . .	163
<b>Chapter 15</b>	<b>Connection Types . . . . .</b>	<b>165</b>
	Connection with a PC Through USB . . . . .	166
	Connection with a USB Memory Key . . . . .	167
	Connection with a PC Through Ethernet . . . . .	168
<b>Chapter 16</b>	<b>BIOS Update . . . . .</b>	<b>169</b>
	Controller Update BIOS . . . . .	169
<b>Appendices</b>	<b>. . . . .</b>	<b>171</b>

---

<b>Appendix A Appendices</b> .....	<b>173</b>
NTC 10k beta 3435 Resistance Temperature Table .....	<b>174</b>
NTC 10k-2 beta (25/50) 3977 Resistance Temperature Table .....	<b>176</b>
Pt1000 Resistance Temperature Table .....	<b>178</b>
<b>Glossary</b> .....	<b>183</b>
<b>Index</b> .....	<b>187</b>

---



## Important Information

### NOTICE

Read these instructions carefully, and look at the equipment to become familiar with the device before trying to install, operate, service, or maintain it. The following special messages may appear throughout this documentation or on the equipment to warn of potential hazards or to call attention to information that clarifies or simplifies a procedure.



The addition of this symbol to a “Danger” or “Warning” safety label indicates that an electrical hazard exists which will result in personal injury if the instructions are not followed.



This is the safety alert symbol. It is used to alert you to potential personal injury hazards. Obey all safety messages that follow this symbol to avoid possible injury or death.

### **DANGER**

**DANGER** indicates a hazardous situation which, if not avoided, **will result in** death or serious injury.

### **WARNING**

**WARNING** indicates a hazardous situation which, if not avoided, **could result in** death or serious injury.

### **CAUTION**

**CAUTION** indicates a hazardous situation which, if not avoided, **could result in** minor or moderate injury.

### **NOTICE**

**NOTICE** is used to address practices not related to physical injury.

### PLEASE NOTE

Electrical equipment should be installed, operated, serviced, and maintained only by qualified personnel. No responsibility is assumed by Schneider Electric for any consequences arising out of the use of this material.

A qualified person is one who has skills and knowledge related to the construction and operation of electrical equipment and its installation, and has received safety training to recognize and avoid the hazards involved.

### Qualification of Personnel

Only appropriately trained persons who are familiar with and understand the contents of this manual and all other pertinent product documentation are authorized to work on and with this product.

The qualified person must be able to detect possible hazards that may arise from parameterization, modifying parameter values and generally from mechanical, electrical, or electronic equipment. The qualified person must be familiar with the standards, provisions, and regulations for the prevention of industrial accidents, which they must observe when designing and implementing the system.

---

## Intended Use

The products described or affected by this document, together with software, accessories, and options, are controllers, intended for commercial HVAC machines according to the instructions, directions, examples, and safety information contained in the present document and other supporting documentation.

The product may only be used in compliance with all applicable safety regulations and directives, the specified requirements, and the technical data.

Prior to using the product, you must perform a risk assessment in view of the planned application. Based on the results, the appropriate safety-related measures must be implemented.

Since the product is used as a component in an overall machine or process, you must ensure the safety of persons by means of the design of this overall system.

Operate the product only with the specified cables and accessories. Use only genuine accessories and spare parts.

Any use other than the use explicitly permitted is prohibited and can result in unanticipated hazards.

## Prohibited Use

Any use other than that expressed above under Permitted use is strictly prohibited.

The relay contacts supplied are of an electromechanical type and subject to wear. Functional safety protection devices, specified in international or local standards, must be installed externally to this device.

## Liability and Residual Risks

The liability of Schneider Electric is limited to the proper and professional use of this product under the guidelines contained in the present and other supporting documents, and does not extend to damages caused by (but not limited to):

- Unspecified installation/use and, in particular, in contravention of the safety requirements of established legislation or specified in this document;
- Use on equipment which does not provide adequate protection against electrocution, water and dust in the actual installation conditions;
- Use on equipment in which dangerous components can be accessed without the use of specific tools;
- Installation/use on equipment which does not comply with established legislation and standards.

## Disposal

The appliance (or the product) must be disposed of separately in compliance with the local standards in force on waste disposal.



# About the Book



## At a Glance

### Document Scope

This document describes the Modicon M172 Logic controllers, expansion modules, remote displays, and accessories, including installation and wiring information.

**NOTE:** Read and understand this document and all related documents (*see page 9*) before installing, operating, or maintaining your controller.

### Validity Note

This document has been updated for the release of EcoStruxure Machine Expert - HVAC V1.0.

For product compliance and environmental information (RoHS, REACH, PEP, EOL, etc.), go to [www.schneider-electric.com/green-premium](http://www.schneider-electric.com/green-premium).

The technical characteristics of the devices described in the present document also appear online. To access the information online:

Step	Action
1	Go to the Schneider Electric home page <a href="http://www.schneider-electric.com">www.schneider-electric.com</a> .
2	In the <b>Search</b> box type the reference of a product or the name of a product range. <ul style="list-style-type: none"><li>• Do not include blank spaces in the reference or product range.</li><li>• To get information on grouping similar modules, use asterisks (*).</li></ul>
3	If you entered a reference, go to the <b>Product Datasheets</b> search results and click on the reference that interests you. If you entered the name of a product range, go to the <b>Product Ranges</b> search results and click on the product range that interests you.
4	If more than one reference appears in the <b>Products</b> search results, click on the reference that interests you.
5	Depending on the size of your screen, you may need to scroll down to see the data sheet.
6	To save or print a data sheet as a .pdf file, click <b>Download XXX product datasheet</b> .

The characteristics that are presented in the present document should be the same as those characteristics that appear online. In line with our policy of constant improvement, we may revise content over time to improve clarity and accuracy. If you see a difference between the document and online information, use the online information as your reference.

### Related Documents

Title of documentation	Reference number
EcoStruxure Machine Expert - HVAC software - Operating Guide	<a href="#">EIO000003412 (ENG)</a>
TM172 Optimized & Performance 7/18 IO Instruction Sheet	<a href="#">QGH90428</a>
TM172 Performance 28/42 IO Instruction Sheet	<a href="#">NHA87740</a>
TM172 Optimized & Performance Isolated 28/42 IO Instruction Sheet	<a href="#">PHA83703</a>
TM172 Optimized & Performance Expansion 12/28 IO Instruction Sheet	<a href="#">QGH26895</a>
TM172DCLW••• Display Color Touchscreen Instruction Sheet	<a href="#">QGH26896</a>
TM172DCLF• Display Color Touchscreen Flush Mounting Instruction Sheet	<a href="#">PHA38669</a>

You can download these technical publications and other technical information from our website at [www.schneider-electric.com/en/download](http://www.schneider-electric.com/en/download).

** DANGER**

**HAZARD OF ELECTRIC SHOCK, EXPLOSION OR ARC FLASH**

- Disconnect all power from all equipment including connected devices prior to removing any covers or doors, or installing or removing any accessories, hardware, cables, or wires except under the specific conditions specified in the appropriate hardware guide for this equipment.
- Always use a properly rated voltage sensing device to confirm the power is off where and when indicated.
- Replace and secure all covers, accessories, hardware, cables, and wires and confirm that a proper ground connection exists before applying power to the unit.
- Use only the specified voltage when operating this equipment and any associated products.

**Failure to follow these instructions will result in death or serious injury.**

This equipment has been designed to operate outside of any hazardous location, and exclusive of applications that generate, or have the potential to generate, hazardous atmospheres. Only install this equipment in zones known to be free, at all times, of hazardous atmospheres.

** DANGER**

**POTENTIAL FOR EXPLOSION**

- Install and use this equipment in non-hazardous locations only.
- Do not install and use this equipment in applications capable of generating hazardous atmospheres, such as those applications employing flammable refrigerants.

**Failure to follow these instructions will result in death or serious injury.**

For information concerning the use of control equipment in applications capable of generating hazardous materials, consult your local, regional, or national standards bureau or certification agency.

** WARNING**

**LOSS OF CONTROL**

- The designer of any control scheme must consider the potential failure modes of control paths and, for certain critical control functions, provide a means to achieve a safe state during and after a path failure. Examples of critical control functions are emergency stop and overtravel stop, power outage and restart.
- Separate or redundant control paths must be provided for critical control functions.
- System control paths may include communication links. Consideration must be given to the implications of unanticipated transmission delays or failures of the link.
- Observe all accident prevention regulations and local safety guidelines.<sup>1</sup>
- Each implementation of this equipment must be individually and thoroughly tested for proper operation before being placed into service.

**Failure to follow these instructions can result in death, serious injury, or equipment damage.**

<sup>1</sup> For additional information, refer to NEMA ICS 1.1 (latest edition), "Safety Guidelines for the Application, Installation, and Maintenance of Solid State Control" and to NEMA ICS 7.1 (latest edition), "Safety Standards for Construction and Guide for Selection, Installation and Operation of Adjustable-Speed Drive Systems" or their equivalent governing your particular location.

** WARNING**

**UNINTENDED EQUIPMENT OPERATION**

- Only use software approved by Schneider Electric for use with this equipment.
- Update your application program every time you change the physical hardware configuration.

**Failure to follow these instructions can result in death, serious injury, or equipment damage.**

## Terminology Derived from Standards

The technical terms, terminology, symbols and the corresponding descriptions in this manual, or that appear in or on the products themselves, are generally derived from the terms or definitions of international standards.

In the area of functional safety systems, drives and general automation, this may include, but is not limited to, terms such as *safety*, *safety function*, *safe state*, *fault*, *fault reset*, *malfunction*, *failure*, *error*, *error message*, *dangerous*, etc.

Among others, these standards include:

Standard	Description
EN 61131-2:2007	Programmable controllers, part 2: Equipment requirements and tests.
ISO 13849-1:2008	Safety of machinery: Safety related parts of control systems. General principles for design.
EN 61496-1:2013	Safety of machinery: Electro-sensitive protective equipment. Part 1: General requirements and tests.
ISO 12100:2010	Safety of machinery - General principles for design - Risk assessment and risk reduction
EN 60204-1:2006	Safety of machinery - Electrical equipment of machines - Part 1: General requirements
EN 1088:2008 ISO 14119:2013	Safety of machinery - Interlocking devices associated with guards - Principles for design and selection
ISO 13850:2006	Safety of machinery - Emergency stop - Principles for design
EN/IEC 62061:2005	Safety of machinery - Functional safety of safety-related electrical, electronic, and electronic programmable control systems
IEC 61508-1:2010	Functional safety of electrical/electronic/programmable electronic safety-related systems: General requirements.
IEC 61508-2:2010	Functional safety of electrical/electronic/programmable electronic safety-related systems: Requirements for electrical/electronic/programmable electronic safety-related systems.
IEC 61508-3:2010	Functional safety of electrical/electronic/programmable electronic safety-related systems: Software requirements.
IEC 61784-3:2008	Digital data communication for measurement and control: Functional safety field buses.
2006/42/EC	Machinery Directive
2014/30/EU	Electromagnetic Compatibility Directive
2014/35/EU	Low Voltage Directive

In addition, terms used in the present document may tangentially be used as they are derived from other standards such as:

Standard	Description
IEC 60034 series	Rotating electrical machines
IEC 61800 series	Adjustable speed electrical power drive systems
IEC 61158 series	Digital data communications for measurement and control – Fieldbus for use in industrial control systems

Finally, the term *zone of operation* may be used in conjunction with the description of specific hazards, and is defined as it is for a *hazard zone* or *danger zone* in the *Machinery Directive (2006/42/EC)* and *ISO 12100:2010*.

**NOTE:** The aforementioned standards may or may not apply to the specific products cited in the present documentation. For more information concerning the individual standards applicable to the products described herein, see the characteristics tables for those product references.



---

# Part I

## Overview

---



---

# Chapter 1

## M172 Range Overview

---

### What Is in This Chapter?

This chapter contains the following topics:

Topic	Page
Modicon M172 Logic Controller Offer Overview	16
Controller Range Overview	17
Expansion Modules Range Overview	19
Communication Modules Range Overview	20
Remote Display Range Overview	21
Accessories	23

## Modicon M172 Logic Controller Offer Overview

### General Description

Modicon M172 Logic Controller are suitable for customized applications designed to control simple or complex machines:

- Air/water-cooled chiller
- Rooftop unit
- Heat pump
- Compressor rack
- Ventilation unit

The M172 offer is made of:

- Controllers (*see page 17*)
- Expansion modules (*see page 19*)
- Communication modules (*see page 20*)
- Remote displays (*see page 21*)
- Accessories (*see page 23*)

### Programming Software

In association with the controllers hardware, the EcoStruxure Machine Expert - HVAC (TM171SW) development tool is available to program and customize applications.

You can download EcoStruxure Machine Expert - HVAC - Programming Software for Modicon M171-M172 Logic Controllers from [Schneider-electric web site download center](#).

The use of several programming languages in accordance with IEC 61131-3 regulations (programming standard for industrial control), makes it possible to develop new algorithms or entire programs easily, which can then be uploaded to the M172 controllers via a PC and a Programming cable, helping to provide confidentiality with appropriate security.

For more information, refer to Connection Types (*see page 165*).



## Controller Range Overview

### Type Code

Controller type code:

Type code description							
TM172PDG42R	TM172	P	D	G	42	R	I
Product family	TM172						
Complementary product family	P = Performance O = Optimized						
Physical feature	B = Blind D = Built-in Display						
Embedded Communication	G = RS-485 and Ethernet based communication protocols M = RS-485 based communication protocols						
Number of I/O						7 18 28 42	
Digital output type						R = Relays S = Solid State Relays (SSR) and Relays	
Power supply isolation <sup>(1)</sup>							I = Power Supply Isolated
<b>(1)</b> Only for 28 and 42 I/O							

### Controllers References

Reference	Complementary product family	Display	Inputs/Outputs				Micro SD card	USB		Communication		
			DI	DO	AI	AO		USB A	USB Mini-B	2 RS-485	1 Ethernet	1 CAN Exp. bus
<b>7 Inputs/Outputs</b> ( <i>see page 54</i> )												
TM172PBG07R	Performance	-	2	3	2	0	✓	✓	✓	✓	✓	✓
TM172PDG07R		✓										
<b>18 Inputs/Outputs</b> ( <i>see page 56</i> )												
TM172PBG18R	Performance	-	2	6	8	2	✓	✓	✓	✓	✓	✓
TM172PDG18R		✓										
TM172PDG18S					4 + 2 SSR							
TM172OBM18R	Optimized	-	2	6	8	2	-	-	✓	✓	-	✓
TM172ODM18R		✓										
<b>28 Inputs/Outputs</b> ( <i>see page 59</i> )												
TM172PBG28R	Performance	-	8	8	8	4	✓	✓	✓	✓	✓	✓
TM172PBG28RI												
TM172PDG28R		✓										
TM172PDG28RI												
TM172PDG28S					6 + 2 SSR							
TM172PDG28SI												
TM172OBM28R	Optimized	-	8	8	8	4	-	-	✓	✓	-	✓
TM172ODM28R		✓										

Reference	Complementary product family	Display	Inputs/Outputs				Micro SD card	USB		Communication		
			DI	DO	AI	AO		USB A	USB Mini-B	2 RS-485	1 Ethernet	1 CAN Exp. bus
<b>42 Inputs/Outputs</b> (see page 62)												
TM172PBG42R	Performance	-	12	12	12	6	✓	✓	✓	✓	✓	
TM172PBG42RI		✓										
TM172PDG42R												
TM172PDG42RI												
TM172PDG42S												10 + 2 SSR
TM172PDG42SI												
TM172OBM42R	Optimized	-	12	12	12	6	-	-	✓	✓	-	✓
TM172ODM42R		✓										

The controller runs on 24 Vac/dc power supply.

**TM172P..... / TM172O..... Delivery Content**

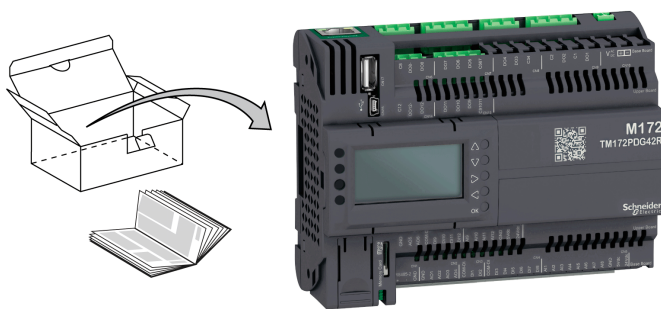

**NOTE:** Terminal blocks are not provided with the logic controllers and must be ordered separately (see page 23)

## Expansion Modules Range Overview

### Type Code

Expansion module type code:

Type code description			
TM172E28R	TM172E	28	R
Product family	TM172E		
Number of I/O		12 28	
Digital output type			R = Relays

### Expansion Modules References

Reference	Inputs/Outputs				1 CAN Exp. bus	1 TTL <sup>(1)</sup>	Compatible controllers
	DI	DO	AI	AO			
<b>12 Inputs/Outputs</b> (see page 66)							
TM172E12R	2	6	4	-	✓	✓	TM172P..... <sup>(2)</sup> TM172O..... <sup>(2)</sup>
<b>28 Inputs/Outputs</b> (see page 68)							
TM172E28R	6	10	10	2	✓	✓	TM172P..... <sup>(2)</sup> TM172O..... <sup>(2)</sup>
<b>(1)</b> For service only.							
<b>(2)</b> Also compatible with TM171P controller range.							

The expansion modules run on 24 Vac/dc power supply.

### TM172E•R Delivery Content

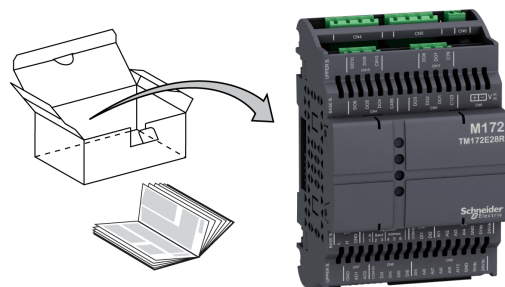

**NOTE:** Terminal blocks are not provided with the expansion modules and must be ordered separately (see page 23)

## Communication Modules Range Overview

### Overview

This section presents communication modules.

### Communication Modules References

Reference	Description	Terminal type	Compatible controllers
TM171ACAN	CAN	2 screw terminal blocks	TM172P..... TM172O..... <sup>(1)</sup>
TM171ALON	LonWorks	1 screw terminal block	
TM171AMB	Modbus SL (RS-485)	2 screw terminal blocks	
TM171ARS232	RS-232 serial link, Relay output	1 SUB-D 9 1 screw terminal block	
TM171ARS485	Modbus SL, and BACnet MS/TP	2 screw terminal blocks	
TM171AETH	Ethernet, Modbus TCP, and BACnet/IP	1 RJ45	TM172O..... <sup>(1)</sup>
TM171AETHRS485	Ethernet, Modbus TCP, BACnet/IP, Modbus SL, and BACnet MS/TP	1 RJ45 2 screw terminal blocks	
<b>(1)</b> Also compatible with TM171P controller range.			

For further information about communication modules, refer to the Modicon M171A Communication Modules Instruction Sheet [EAV96007](#).

## Remote Display Range Overview

### Type Code

Remote display type code:

Type code description					
TM172DCLWTHP	TM172DCL	W	T	H	P
Product family	TM172DCL				
Mounting type		W = Vertical mounting F = Flush mounting			
Characteristics		G = Gray color W = White color T = Temperature sensor			
		None H = Relative humidity sensor			
		None P = Presence sensor (PIR)			

### Remote Displays References

Reference	Embedded sensors			1 RS-485	1 USB Micro-B	Compatible controllers
	Temperature	Humidity	Presence			
TM172DCLWT <i>(see page 124)</i>	✓	-	-	✓	✓	TM172P.....
TM172DCLWTH <i>(see page 124)</i>	✓	✓	-	✓	✓	TM172O.....
TM172DCLWTHP <i>(see page 124)</i>	✓	✓	✓	✓	✓	TM171P.....
TM172DCLFG <i>(see page 125)</i>	-	-	-	✓	✓	TM171O.....
TM172DCLFW <i>(see page 125)</i>	-	-	-	✓	✓	Third-party Modbus SL devices

The remote displays runs on 24 Vac/dc power supply.

### TM172DCLWT•• Delivery Content

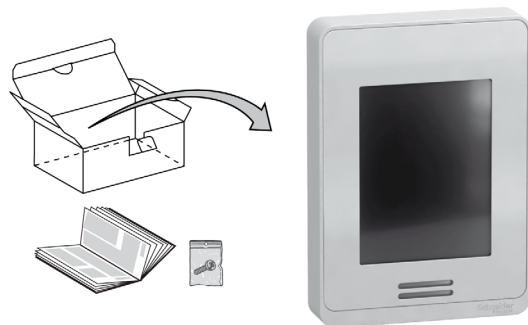

**TM172DCLF • Delivery Content**

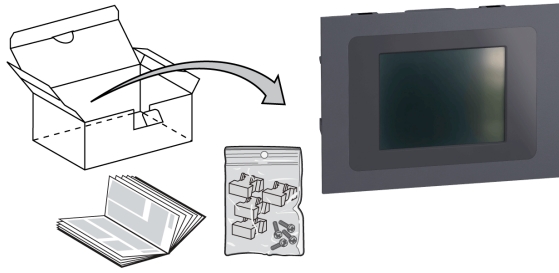

## Accessories

### Overview

This section describes the accessories and sensors.

### Mounting and Wiring Accessories References

Description		Use	Reference
TM172DCLF• vertical surface support for display	Gray	To install a TM172DCLF• on a vertical surface	TM172ABKPG
	White		TM172ABKPW
12 clips-on lock		To install the TM172••••• controllers and the expansion modules on a panel surface ( <i>see page 43</i> )	TM172AP12PM
Screw terminal blocks for wiring of controllers and expansion modules ( <i>see page 30</i> )		For TM172P•G07R ( <i>see page 54</i> )	TM172ASCTB07
		For TM172•••18• ( <i>see page 56</i> )	TM172ASCTB18
		For TM172•••28•• ( <i>see page 59</i> )	TM172ASCTB28
		For TM172•••42•• ( <i>see page 62</i> )	TM172ASCTB42
		For TM172E12R ( <i>see page 66</i> )	TM172ASCTB12E
		For TM172E28R ( <i>see page 68</i> )	TM172ASCTB28E
USB cable type A / Mini-B	1.8 m (5.9 ft)	To connect a PC to a TM172••••• controller ( <i>see page 166</i> )	BMXXCAUSBH018
	3 m (9.84 ft)		TCSXCNAMUM3P
DIN adapter for current transducer	3240202000	To install the current transducer on a DIN Rail Top Hat	3240301000

### Sensors References

Description	Cable length	Reference
NTC IP68 5x20 mm (0.79 in.) -50+110°C (-122...+230°F) Gray	8 pieces	1.5 m (4.9 ft)
	100 pieces	
	5 pieces	3 m (9.8 ft)
	50 pieces	
	4 pieces	5 m (16.4 ft)
	25 pieces	
NTC IP67 6x15 mm (0.591 in.) -50...+110°C (-122...+230°F) Gray	1.5 m (4.9 ft)	TM1STNTCRN61515
	3 m (9.8 ft)	TM1STNTCRN61530
	5 m (16.4 ft)	TM1STNTCRN61550
NTC FAST IP67 4x40 mm (1.57 in.) -50+110°C (-122...+230°F) Gray	1.5 m (4.9 ft)	TM1STNTCSF44015
	3 m (9.8 ft)	TM1STNTCSF44030
NTC IP68 6x20 mm (0.79 in.) -50+110°C (-122...+230°F) Gray	1.5 m (4.9 ft)	TM1STNTCSN62015
	3 m (9.8 ft)	TM1STNTCSN62030
	5 m (16.4 ft)	TM1STNTCSN62050
NTC IP68 6x20 mm (0.79 in.) TPE with strap Gray	1.5 m (4.9 ft)	TM1STNTCTN62015
	3 m (9.8 ft)	TM1STNTCTN62030
NTC for inside air -40...+60°C (-40...+140°F)	Wall mounting	-
Pt1000 IP68 6x20 mm (0.79 in.) -50...+110°C (-122...+230°F) Green	1.5 m (4.9 ft)	TM1STPTTSN52015
	3 m (9.8 ft)	TM1STPTTSN52030
	5 m (16.4 ft)	TM1STPTTSN52050
Pt1000 IP68 5x20 mm (0.79 in.) -50...+110°C (-122...+230°F) Green	1.5 m (4.9 ft)	TM1STPTTSN62015
	3 m (9.8 ft)	TM1STPTTSN62030
Humidity Probe Outdoor Wall mounting 4...20 mA (%RH)	-	TM1SHC4
Humidity and Temperature Probe Outdoor Wall mounting 4...20 mA (%RH) + NTC (Temp)	-	TM1SHTCN4

---

Description	Cable length	Reference
Humidity and Temperature Probe Outdoor Wall mounting 4...20 mA (%RH) + 4...20 mA (Temp)	-	TM1SHTCC4
Humidity and Temperature Probe Outdoor Wall mounting, Dewpoint Calculation Modbus SL RS485		TM1SHTM4
NTC Temperature Probe Outdoor Wall mounting	-	TM1STNTCW69755



---

# Part II

## Global Features

---

### What Is in This Part?

This part contains the following chapters:

Chapter	Chapter Name	Page
2	Before Starting	27
3	Wiring Best Practices	29
4	Installation	35



---

## Chapter 2

### Before Starting

---

#### Before Starting

##### Before Starting

Read and understand this chapter before beginning the installation of your system.

Pay particular attention in conforming to any safety information, different electrical requirements, and normative standards that would apply to your machine or process in the use of this equipment.

The use and application of the information contained herein require expertise in the design and programming of automated control systems. Only you, the user, machine builder or integrator, can be aware of all the conditions and factors present during installation and setup, operation, and maintenance of the machine or process, and can therefore determine the automation and associated equipment and the related safeties and interlocks which can be effectively and properly used. When selecting automation and control equipment, and any other related equipment or software, for a particular application, you must also consider any applicable local, regional or national standards and/or regulations.

#### **WARNING**

##### **REGULATORY INCOMPATIBILITY**

Ensure that all equipment applied and systems designed comply with all applicable local, regional, and national regulations and standards.

**Failure to follow these instructions can result in death, serious injury, or equipment damage.**

#### Disconnecting Power

All options and modules should be assembled and installed before installing the control system on a mounting rail, onto a mounting plate or in a panel. Remove the control system from its mounting rail, mounting plate or panel before disassembling the equipment.

#### **DANGER**

##### **HAZARD OF ELECTRIC SHOCK, EXPLOSION OR ARC FLASH**

- Disconnect all power from all equipment including connected devices prior to removing any covers or doors, or installing or removing any accessories, hardware, cables, or wires except under the specific conditions specified in the appropriate hardware guide for this equipment.
- Always use a properly rated voltage sensing device to confirm the power is off where and when indicated.
- Replace and secure all covers, accessories, hardware, cables, and wires and confirm that a proper ground connection exists before applying power to the unit.
- Use only the specified voltage when operating this equipment and any associated products.

**Failure to follow these instructions will result in death or serious injury.**

#### Programming Considerations

The products described in this manual have been designed and tested using Schneider Electric programming, configuration, and maintenance software products.

#### **WARNING**

##### **UNINTENDED EQUIPMENT OPERATION**

- Only use software approved by Schneider Electric for use with this equipment.
- Update your application program every time you change the physical hardware configuration.

**Failure to follow these instructions can result in death, serious injury, or equipment damage.**

### Operating Environment

This equipment has been designed to operate outside of any hazardous location. Only install this equipment in zones known to be free of a hazardous atmosphere.

<b>⚠ DANGER</b>
<b>POTENTIAL FOR EXPLOSION</b>
Install and use this equipment in non-hazardous locations only.
<b>Failure to follow these instructions will result in death or serious injury.</b>

<b>⚠ WARNING</b>
<b>UNINTENDED EQUIPMENT OPERATION</b>
Install and operate this equipment according to the conditions described in the Environmental Characteristics.
<b>Failure to follow these instructions can result in death, serious injury, or equipment damage.</b>

### Installation Considerations

<b>⚠ WARNING</b>
<b>UNINTENDED EQUIPMENT OPERATION</b>
<ul style="list-style-type: none"><li>● Use appropriate safety interlocks where personnel and/or equipment hazards exist.</li><li>● Install and operate this equipment in an enclosure appropriately rated for its intended environment and secured by a keyed or tooled locking mechanism.</li><li>● Use the sensor and actuator power supplies only for supplying power to the sensors or actuators connected to the module.</li><li>● Power line and output circuits must be wired and fused in compliance with local and national regulatory requirements for the rated current and voltage of the particular equipment.</li><li>● Do not use this equipment in safety-critical machine functions unless the equipment is otherwise designated as functional safety equipment and conforming to applicable regulations and standards.</li><li>● Do not disassemble, repair, or modify this equipment.</li><li>● Do not connect any wiring to unused connections, or to connections designated as No Connection (N.C.).</li></ul>
<b>Failure to follow these instructions can result in death, serious injury, or equipment damage.</b>

**NOTE:** JDYX2 or JDYX8 fuse types are UL-recognized and CSA approved.

The M172 controllers are intended for Top Hat Section Rail (DIN rail) mounting, panel mounting, or wall mounting.

Care must be taken to avoid damage from electrostatic sources when handling this equipment. In particular exposed connectors and, in some cases, exposed printed circuit boards are exceptionally vulnerable to electrostatic discharge.

<b>⚠ WARNING</b>
<b>UNINTENDED EQUIPMENT OPERATION DUE TO ELECTROSTATIC DISCHARGE DAMAGE</b>
<ul style="list-style-type: none"><li>● Keep equipment in the protective conductive packaging until you are ready to install the equipment.</li><li>● Only install equipment in approved enclosures and / or locations that prevent casual access and provide electrostatic discharge protection.</li><li>● Use a conductive wrist strap or equivalent field force protective device attached to an earth ground when handling sensitive equipment.</li><li>● Always discharge yourself by touching a grounded surface or approved antistatic mat before handling the equipment.</li></ul>
<b>Failure to follow these instructions can result in death, serious injury, or equipment damage.</b>

For more information about enclosures, refer to the definition found in IEC 1000-4-2.

---

# Chapter 3

## Wiring Best Practices

---

### Wiring Best Practices

#### Wiring Best Practices

The following information describes the wiring guidelines and associated best practices to be respected when using a Modicon M172 Logic Controller.

 <b>DANGER</b>
<b>HAZARD OF ELECTRIC SHOCK, EXPLOSION OR ARC FLASH</b> <ul style="list-style-type: none"><li>• Disconnect all power from all equipment including connected devices prior to removing any covers or doors, or installing or removing any accessories, hardware, cables, or wires except under the specific conditions specified in the appropriate hardware guide for this equipment.</li><li>• Always use a properly rated voltage sensing device to confirm the power is off where and when indicated.</li><li>• Replace and secure all covers, accessories, hardware, cables, and wires and confirm that a proper ground connection exists before applying power to the unit.</li><li>• Use only the specified voltage when operating this equipment and any associated products.</li></ul> <b>Failure to follow these instructions will result in death or serious injury.</b>

 <b>WARNING</b>
<b>LOSS OF CONTROL</b> <ul style="list-style-type: none"><li>• The designer of any control scheme must consider the potential failure modes of control paths and, for certain critical control functions, provide a means to achieve a safe state during and after a path failure. Examples of critical control functions are emergency stop and overtravel stop, power outage and restart.</li><li>• Separate or redundant control paths must be provided for critical control functions.</li><li>• System control paths may include communication links. Consideration must be given to the implications of unanticipated transmission delays or failures of the link.</li><li>• Observe all accident prevention regulations and local safety guidelines.<sup>1</sup></li><li>• Each implementation of this equipment must be individually and thoroughly tested for proper operation before being placed into service.</li></ul> <b>Failure to follow these instructions can result in death, serious injury, or equipment damage.</b>

<sup>1</sup> For additional information, refer to NEMA ICS 1.1 (latest edition), "Safety Guidelines for the Application, Installation, and Maintenance of Solid State Control" and to NEMA ICS 7.1 (latest edition), "Safety Standards for Construction and Guide for Selection, Installation and Operation of Adjustable-Speed Drive Systems" or their equivalent governing your particular location.

#### Wiring Guidelines

The following rules must be applied when wiring M172 offer product range:

- I/O and communication wiring must be kept separate from the power wiring. Route these two types of wiring in separate cable ducting.
- Verify that the operating conditions and environment are within the specification values.
- Use proper wire sizes to meet voltage and current requirements.
- Use copper conductors (required).
- Use twisted pair, shielded cables for analog, and/or fast I/O.
- Use twisted pair, shielded cables for networks, and fieldbus.

Use shielded, properly grounded cables for all analog and high-speed inputs or outputs and communication connections. If you do not use shielded cable for these connections, electromagnetic interference can cause signal degradation. Degraded signals can cause the controller or attached modules and equipment to perform in an unintended manner.

**⚠ WARNING**

**UNINTENDED EQUIPMENT OPERATION**

- Use shielded cables for all fast I/O, analog I/O and communication signals.
- Ground cable shields for all analog I/O, fast I/O and communication signals at a single point<sup>1</sup>.
- Route communication and I/O cables separately from power cables.









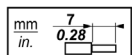

**Failure to follow these instructions can result in death, serious injury, or equipment damage.**



<sup>1</sup>Multipoint grounding is permissible if connections are made to an equipotential ground plane dimensioned to help avoid cable shield damage in the event of power system short-circuit currents.

**NOTE:** Surface temperatures may exceed 60 °C (140 °F). Route primary wiring (wires connected to power mains) separately and apart from secondary wiring (extra low voltage wiring coming from intervening power sources). If that is not possible, double insulation is required such as conduit or cable gains.





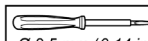



**Rules for Screw Terminal Block**

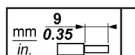

The following table presents the cable types and wire sizes for a 5.08 mm (0.20 in.) or 5.00 mm (0.197 in.) pitch screw terminal block:

									
mm <sup>2</sup>	0.2...2.5	0.2...2.5	0.25...2.5	0.25...2.5	2 x 0.2...1	2 x 0.2...1.5	2 x 0.25...1	2 x 0.5...1.5	2 x 0.5...1.5
AWG	24...14	24...14	22...14	22...14	2 x 24...18	2 x 24...16	2 x 22...18	2 x 20...16	2 x 20...16

	
Ø 3,5 mm (0.14 in.)	
N•m	0.5...0.6
lb-in	4.42...5.31

The following table presents the cable types and wire sizes for a 3.81 mm (0.15 in.) or 3.50 mm (0.14 in.) pitch screw terminal block:

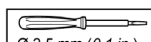
								
mm <sup>2</sup>	0.14...1.5	0.14...1.5	0.25...1.5	0.25...0.5	2 x 0.08...0.5	2 x 0.08...0.75	2 x 0.25...0.34	2 x 0.5
AWG	26...16	26...16	22...16	22...20	2 x 28...20	2 x 28...20	2 x 24...22	2 x 20

		N•m	0.22...0.25
Ø 2,5 mm (0.1 in.)		lb-in	1.95...2.21

The use of copper conductors is required.

**⚡ ⚠ DANGER**

**LOOSE WIRING CAUSES ELECTRIC SHOCK**

Tighten connections in conformance with the torque specifications.

**Failure to follow these instructions will result in death or serious injury.**

**⚠ WARNING****FIRE HAZARD**

- Use only the recommended wire sizes for the current capacity of the I/O channels and power supplies.
- For relay output wiring up to 2 A, use conductors of at least 0.5 mm<sup>2</sup> (AWG 20) with a temperature rating of at least 80 °C (176 °F).
- For relay output wiring of 3 A, use conductors of at least 1.5 mm<sup>2</sup> (AWG 16) with a temperature rating of at least 80 °C (176 °F).
- For common conductors of relay output wiring of 9 A, or relay output wiring greater than 3 A, use conductors of at least 2.0 mm<sup>2</sup> (AWG 12) with a temperature rating of at least 80 °C (176 °F).

**Failure to follow these instructions can result in death, serious injury, or equipment damage.**

**Protecting Outputs from Inductive Load Damage**

Depending on the load, a protection circuit may be needed for the relay outputs. Inductive loads using DC voltages may create voltage reflections resulting in overshoot that will damage or shorten the life of output devices.

**⚠ CAUTION****OUTPUT CIRCUIT DAMAGE DUE TO INDUCTIVE LOADS**

Use an appropriate external protective circuit or device to reduce the risk of inductive direct current load damage.

**Failure to follow these instructions can result in injury or equipment damage.**

Choose a protection circuit from the following diagrams according to the power supply used. Connect the protection circuit to the outside of the controller or relay output module.

If your controller or module contains relay outputs, these types of outputs can support up to 240 Vac. Inductive damage to these types of outputs can result in welded contacts and loss of control. Each inductive load must include a protection device such as a peak limiter, RC circuit or flyback diode. Capacitive loads are not supported by these relays.

**⚠ WARNING****RELAY OUTPUTS WELDED CLOSED**

- Always protect relay outputs from inductive alternating current load damage using an appropriate external protective circuit or device.
- Do not connect relay outputs to capacitive loads.

**Failure to follow these instructions can result in death, serious injury, or equipment damage.**

Protective circuit A: this protection circuit can be used for both AC and DC load power circuits.

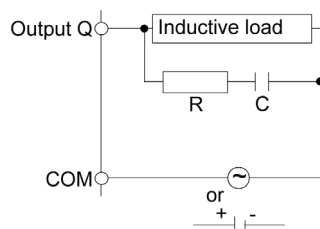

C Value from 0.1 to 1 μF

R Resistor of approximately the same resistance value as the load

Protective circuit B: this protection circuit can be used for DC load power circuits.

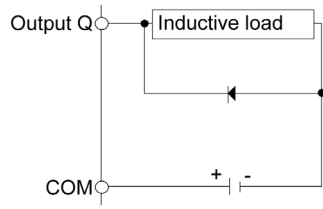

Use a diode with the following ratings:

- Reverse withstand voltage: power voltage of the load circuit x 10.
- Forward current: more than the load current.

Protective circuit C: this protection circuit can be used for both AC and DC load power circuits.

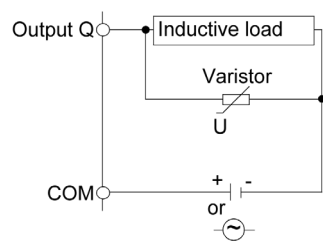

In applications where the inductive load is switched on and off frequently and/or rapidly, verify that the continuous energy rating (J) of the varistor exceeds the peak load energy by 20 % or more.

**NOTE:** Place protection devices as close to the load as possible.

**Special Handling Considerations**

Care must be taken to avoid damage from electrostatic sources when handling this equipment. In particular exposed connectors and, in some cases, exposed printed circuit boards are exceptionally vulnerable to electrostatic discharge.

<b>⚠ WARNING</b>
<p><b>UNINTENDED EQUIPMENT OPERATION DUE TO ELECTROSTATIC DISCHARGE DAMAGE</b></p> <ul style="list-style-type: none"> <li>● Keep equipment in the protective conductive packaging until you are ready to install the equipment.</li> <li>● Only install equipment in approved enclosures and / or locations that prevent casual access and provide electrostatic discharge protection.</li> <li>● Use a conductive wrist strap or equivalent field force protective device attached to an earth ground when handling sensitive equipment.</li> <li>● Always discharge yourself by touching a grounded surface or approved antistatic mat before handling the equipment.</li> </ul> <p><b>Failure to follow these instructions can result in death, serious injury, or equipment damage.</b></p>

**Analog Inputs-Probes**

Temperature probes have no connection polarity and can be extended using a normal bipolar cable. The extension of the probes wiring influences the electromagnetic compatibility (EMC) of the instrument. Check the polarity for probes which have a specific connection polarity.

<b>NOTICE</b>
<p><b>INOPERABLE EQUIPMENT</b></p> <p>Verify all wiring connections before applying power.</p> <p><b>Failure to follow these instructions can result in equipment damage.</b></p>



Do not power any connected devices that are externally powered without also applying power to the M172.

## ***NOTICE***

### **INOPERABLE EQUIPMENT**

Ensure that the controller has power applied when applying power to other connected and externally powered devices.

**Failure to follow these instructions can result in equipment damage.**

Signal leads (probes, digital inputs, communication, and the electronic supply) must be routed separately from power cables.



---

# Chapter 4

## Installation

---

### What Is in This Chapter?

This chapter contains the following topics:

Topic	Page
TM172•••07• / TM172•••18• Controllers Mounting Positions	36
TM172•••28•• / TM172•••42•• Controllers Mounting Positions	37
TM172E••R Expansion Modules Mounting Positions	38
Controllers and Expansion Modules Clearances	39
Top Hat Section Rail (DIN Rail)	40
Controllers and Expansion Modules Installation	43
TM172DCLWT•• Remote Display Installation	45
TM172DCLF• Remote Display Installation	46

## TM172...07 / TM172...18 Controllers Mounting Positions

### Correct Mounting Position

TM172...07 / TM172...18 controllers must be mounted horizontally on a vertical plane as shown in the figure below:

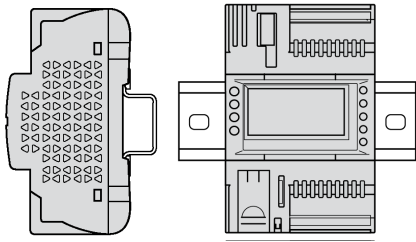

### Incorrect Mounting Position

TM172...07 / TM172...18 controllers cannot be mounted neither vertically, nor horizontally backward:

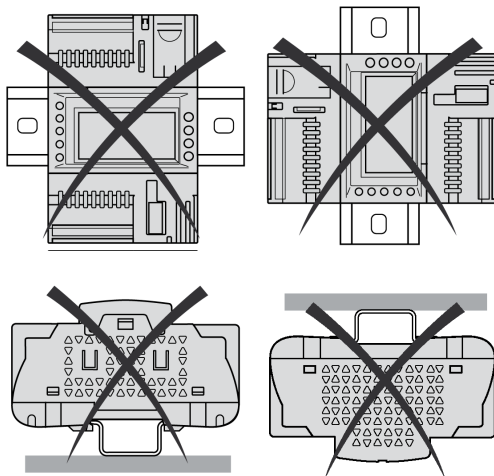

## TM172...28... / TM172...42... Controllers Mounting Positions

### Correct Mounting Position

TM172...28... / TM172...42... controllers should be mounted horizontally on a vertical plane as shown in the figure below:

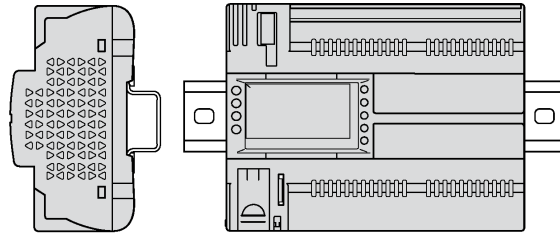

### Acceptable Mounting Position

TM172...28R... / TM172...42R... controllers can be mounted horizontally upward with a temperature derating (maximum ambient temperature: 60 °C (140 °F)).

TM172PDG28SI / TM172PDG42SI controllers can be mounted horizontally upward with a temperature derating (maximum ambient temperature: 55 °C (131 °F)).

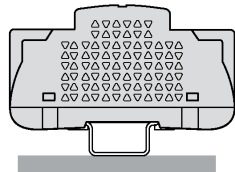

### Incorrect Mounting Position

TM172...28... / TM172...42... controllers cannot be mounted neither vertically, nor horizontally backward:

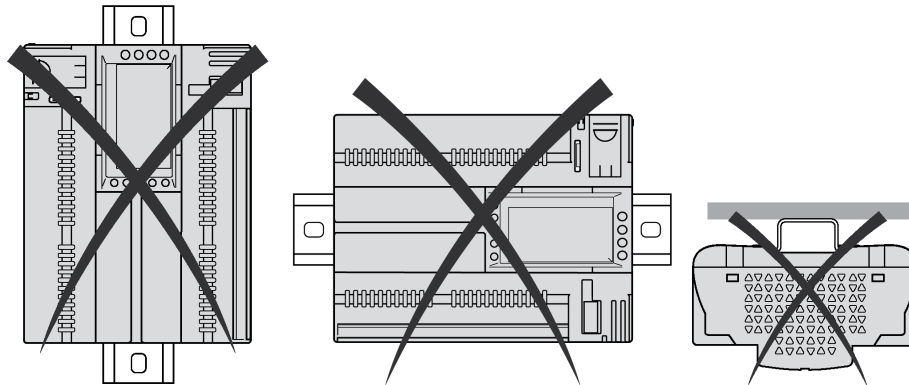

TM172PDG28S / TM172PDG42S controllers cannot be mounted horizontally upward:

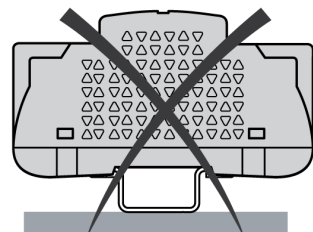

## TM172E••R Expansion Modules Mounting Positions

### Correct Mounting Position

TM172E••R expansion modules must be mounted horizontally on a vertical plane or horizontally upward as shown in the figure below:

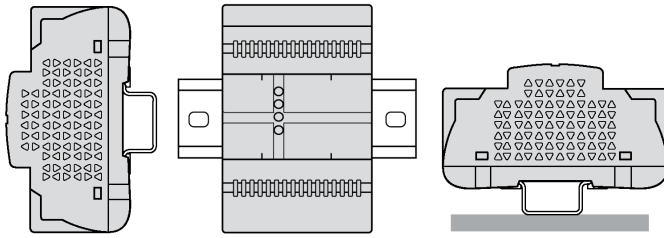

### Incorrect Mounting Position

TM172E••R expansion modules cannot be mounted neither vertically, nor horizontally backward:

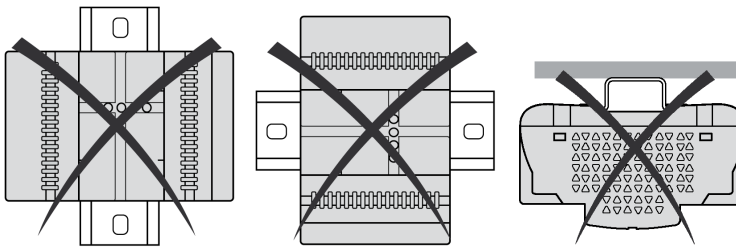

## Controllers and Expansion Modules Clearances

### Minimum Clearances

#### **⚠ WARNING**

##### **UNINTENDED EQUIPMENT OPERATION**

- Place devices dissipating the most heat at the top of the cabinet and ensure adequate ventilation.
- Avoid placing this equipment next to or above devices that might cause overheating.
- Install the equipment in a location providing the minimum clearances from all adjacent structures and equipment as directed in this document.
- Install all equipment in accordance with the specifications in the related documentation.

**Failure to follow these instructions can result in death, serious injury, or equipment damage.**

TM172••••• controllers and expansion modules have been designed as IP20 products and must be installed in an enclosure appropriately rated for its intended environment and secured by a keyed or tooled locking mechanism .

There are 3 types of clearances between:

- The M172 device and the sides of the cabinet (including the panel door).
- The M172 device terminal blocks and the wiring ducts. This distance reduces electromagnetic interference between the controller and the wiring ducts.
- The M172 device and other heat generating devices installed in the same cabinet.

The following figure shows the minimum clearances that apply to TM172••••• references:

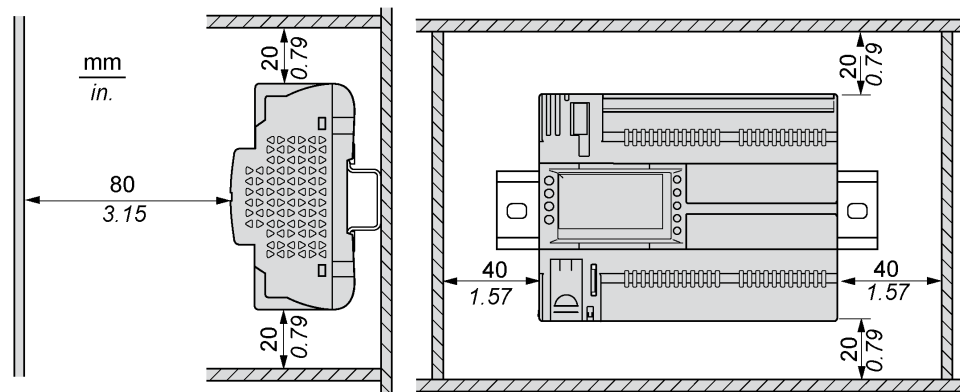

## Top Hat Section Rail (DIN Rail)

### Dimensions of Top Hat Section Rail (DIN Rail)

You can mount the controller and expansion module on a 35 mm (1.38 in.) top hat section rail (DIN rail). It can be attached to a smooth mounting surface or suspended from a EIA rack or mounted in a NEMA cabinet.

### Symmetric Top Hat Section Rails (DIN Rail)

The following illustration and table show the references of the top hat section rails (DIN rail) for the wall-mounting range:

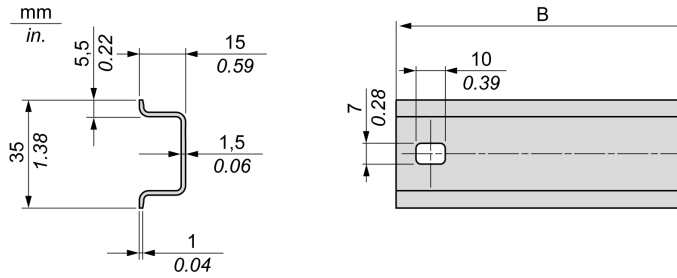

Reference	Type	Rail length (B)
NSYSDR50A	A	450 mm (17.71 in.)
NSYSDR60A	A	550 mm (21.65 in.)
NSYSDR80A	A	750 mm (29.52 in.)
NSYSDR100A	A	950 mm (37.40 in.)

The following illustration and table show the references of the symmetric top hat section rails (DIN rail) for the metal enclosure range:

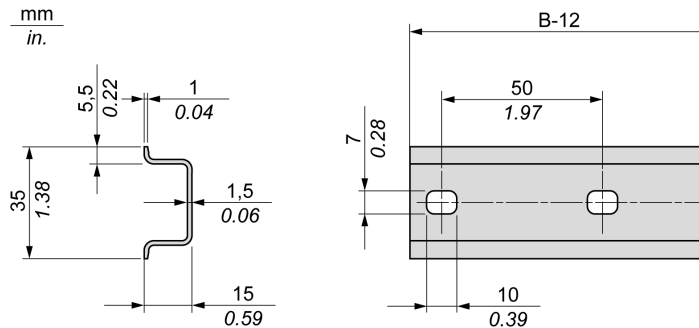

Reference	Type	Rail length (B-12 mm)
NSYSDR60	A	588 mm (23.15 in.)
NSYSDR80	A	788 mm (31.02 in.)
NSYSDR100	A	988 mm (38.89 in.)
NSYSDR120	A	1188 mm (46.77 in.)



The following illustration and table shows the references of the symmetric top hat section rails (DIN rail) of 2000 mm (78.74 in.):

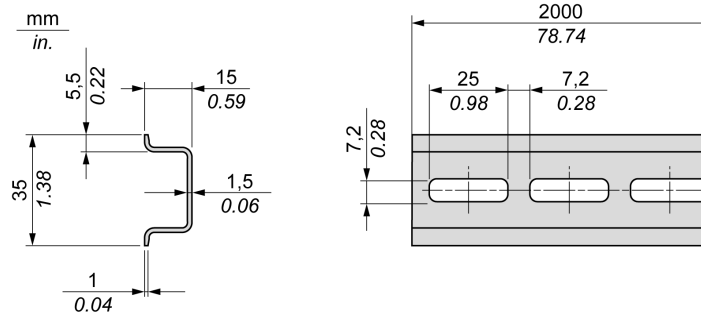

Reference	Type	Rail length
NSYSDR200 <sup>1</sup>	A	2000 mm (78.74 in.)
NSYSDR200D <sup>2</sup>	A	
<sup>1</sup> Unperforated galvanized steel <sup>2</sup> Perforated galvanized steel		

### Double-Profile Top Hat Section Rails (DIN Rail)

The following illustration and table show the references of the double-profile top hat section rails (DIN rails) for the wall-mounting range:

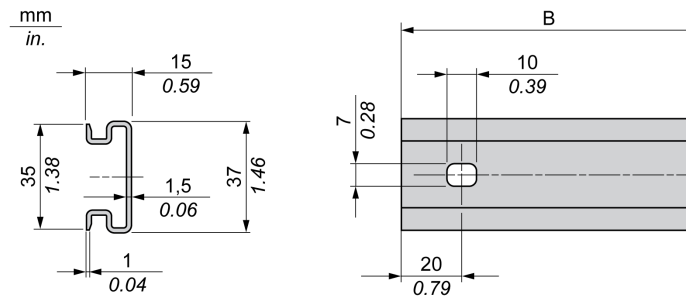

Reference	Type	Rail length (B)
NSYDPR25	W	250 mm (9.84 in.)
NSYDPR35	W	350 mm (13.77 in.)
NSYDPR45	W	450 mm (17.71 in.)
NSYDPR55	W	550 mm (21.65 in.)
NSYDPR65	W	650 mm (25.60 in.)
NSYDPR75	W	750 mm (29.52 in.)

The following illustration and table show the references of the double-profile top hat section rails (DIN rail) for the floor-standing range:

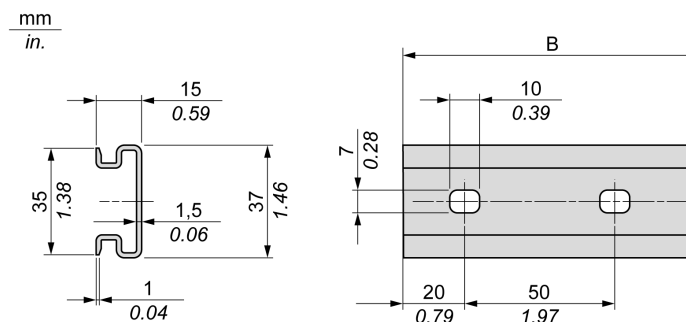

<b>Reference</b>	<b>Type</b>	<b>Rail length (B)</b>
NSYDPR60	F	588 mm (23.15 in.)
NSYDPR80	F	788 mm (31.02 in.)
NSYDPR100	F	988 mm (38.89 in.)
NSYDPR120	F	1188 mm (46.77 in.)

## Controllers and Expansion Modules Installation

### Overview

This section describes how to install and remove a TM172••••• controller or expansion module from a top hat section rail (DIN rail).

### Installing on a Top Hat Section Rail (DIN Rail)

The following procedure describes how to install a controller or an expansion module on a top hat section rail (DIN rail):

Step	Action
1	Move the two spring docking devices to their standby position (use a screwdriver to press against the relative compartments).
2	Position the top groove of the controller or the expansion modules on the top edge of the Top Hat Section Rail (DIN rail).
3	Press the assembly against the Top Hat Section Rail (DIN rail).
4	Press the spring docking devices to put them into the locked position.

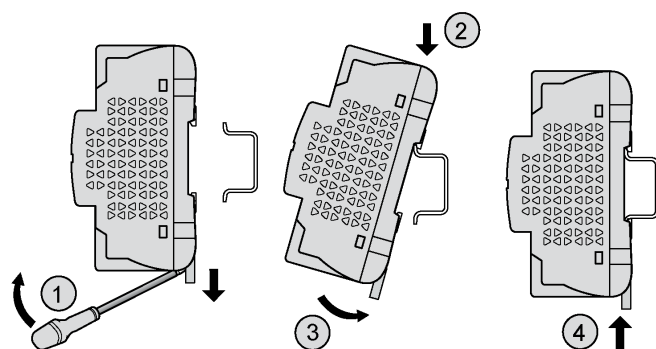

### Removing from a Top Hat Section Rail (DIN Rail)

The following procedure describes how to remove a controller or an expansion module from a top hat section rail (DIN rail):

Step	Action
1	Remove the power from the controller or the expansion module.
2	Insert a flat screwdriver into the spring docking devices.
3	Pull down the spring docking device to move it to its standby position.
4	Pull the controller or the expansion module from the top hat section rail (DIN rail) from the bottom.

### Panel Installation

To install the controllers and expansion modules on a panel you must use clip-on locks.

**NOTE:** Upper clip-on locks are not provided with the logic controllers and must be ordered separately (*see page 23*). Only one additional upper clip-on lock is necessary for TM172P•G07R, TM172•••18•, and TM172E••R.

The following procedure shows how to install a TM172...28... or a TM172...42... controller on a panel using the clip-on locks. The same procedure shall be followed for the TM172P... / TM172O... / TM172E...R:

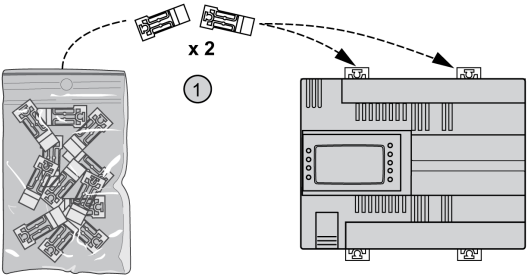
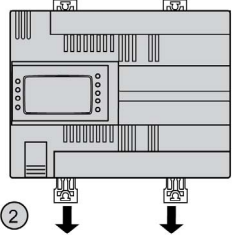
Step	Action
1	Install the 2 upper clip-on locks 
2	Move the 2 lower clip-on locks to their standby position 
3	Secure the device in position with 4 screws. Refer to the mounting holes layout ( <a href="#">see page 44</a> ).

Mounting Holes Layout

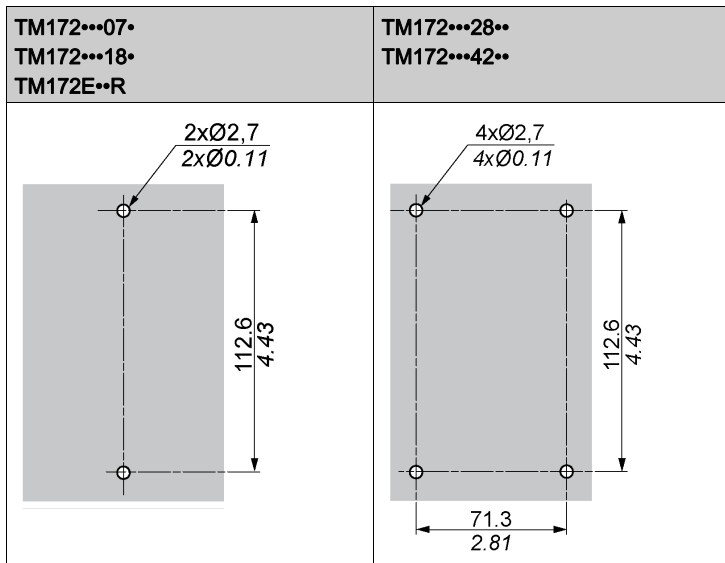

## TM172DCLWT•• Remote Display Installation

### TM172DCLWT•• Panel installation

The TM172DCLWT•• remote display can be mounted horizontally or vertically on a vertical wall.

TM172DCLWT•• display incorporates a temperature sensor. To function correctly, air must circulate through the product to accurately determine the temperature.

### NOTICE

#### INACCURATE TEMPERATURE MEASUREMENT

Mount the TM172DCLWT•• in an upright, vertical (portrait) position when using the temperature sensor.

**Failure to follow these instructions can result in equipment damage.**

The following graphic and procedure explain how to install TM172DCLWT•• remote display on a wall:

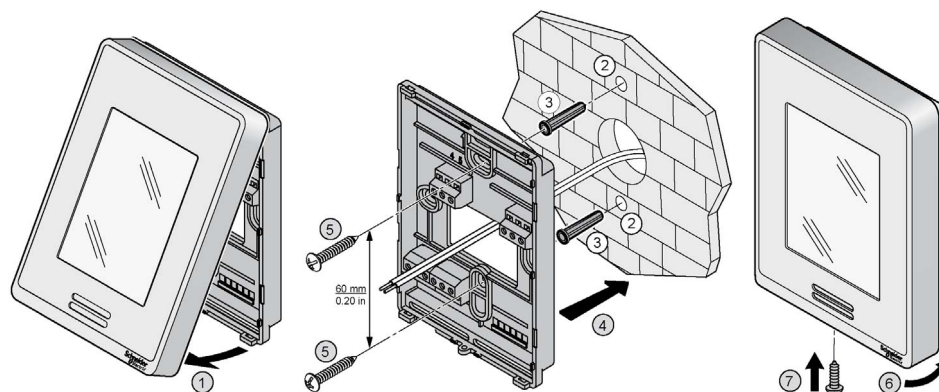

Step	Action
1	Open unit by pulling on bottom side of the display(1)
2	Ensure correct side of base faces up
3	Pull cables 150 mm (5.90 in.) out from wall
4	Align base and mark location of two mounting holes on wall or panel (2)
5	Install anchors in wall (3)
6	Insert cable in central hole of base
7	Place rear cover on the wall and align it with mounting holes (4)
8	Insert screws in mounting holes on each side of base (5)
9	Strip each wire 6 mm (0.24 in.) from end
10	Insert each wire according to wiring chart ( <a href="#">see page 29</a> )
11	Gently push excess wiring back into hole
12	Gently align cover to top of base and snap in place from bottom (6)
13	Install the isolated screw connection for securing the plastic housing (7)

### Mounting Holes Layout

Mounting holes layout for TM172DCLWT••:

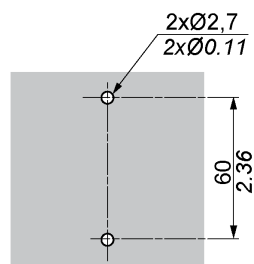

## TM172DCLF• Remote Display Installation

### TM172DCLF• Wiring

The TM172DCLF• remote display must be wired prior to the mounting phase.

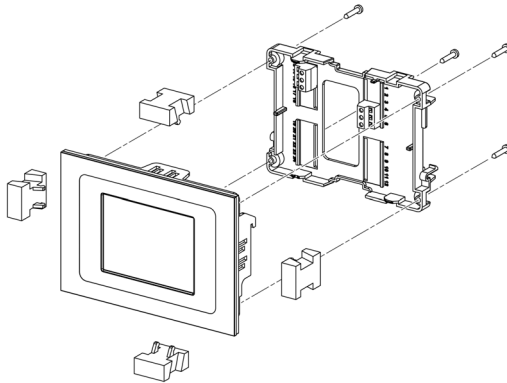

The following procedure explain how to wire a TM172DCLF• remote display:

Step	Action
1	Open unit by pulling on bottom side of the display
2	Insert cable in central hole of base
3	Strip each wire 6 mm (0.24 in.) from end
4	Insert each wire according to wiring chart ( <i>see page 29</i> )
5	Gently align cover to top of base and snap in place.
6	Install the 4 isolated screws connection for securing the plastic housing

### TM172DCLF• Panel Installation

The TM172DCLF• remote display can be mounted horizontally or vertically on a vertical panel.

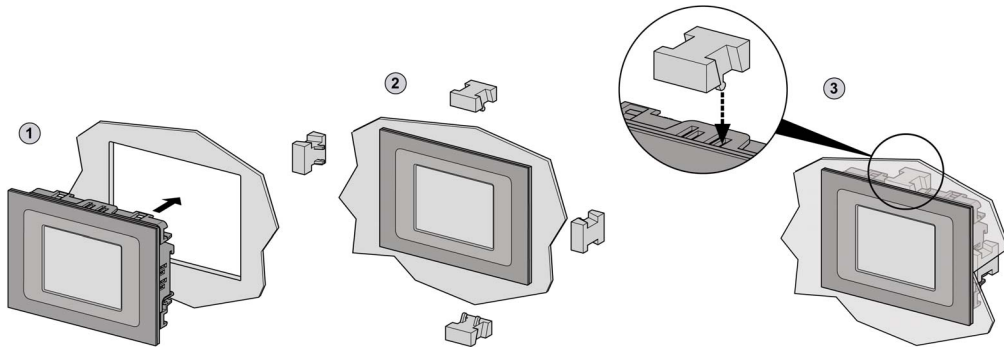

The following procedure explain how to install a TM172DCLF• remote display on a panel:

Step	Action
1	Make a hole using the mounting hole layout.
2	Pull cables 150 mm (5.90 in.) out from hole.
3	Wire the unit according to the wiring procedure.
4	Insert the unit in the hole (1).
5	Secure it with 4 panel mounting locks provided (2)(3).

### TM172DCLF• Vertical Surface Installation

The TM172DCLF• remote display can be mounted horizontally or vertically on a vertical surface using TM172ABKPG or TM172ABKPW accessory.

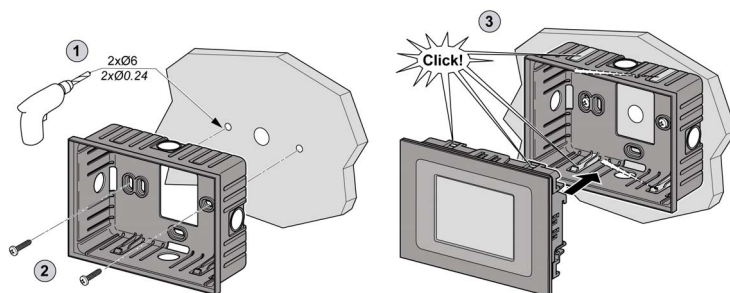

The following procedure explain how to install TM172DCLF• remote display on a vertical surface:

Step	Action
1	Place the TM172ABKP• accessory.
2	Ensure correct side of TM172ABKP• faces up.
3	Pull cables 150 mm (5.90 in.) out from vertical surface if necessary.
4	Align TM172ABKP• and mark location of two mounting holes on the vertical surface.
5	Drill holes in the vertical surface (1).
6	Pull cables 150 mm (5.90 in.) out from a hole of TM172ABKP•.
7	Place TM172ABKP• on the vertical surface and align it with mounting holes.
8	Insert screws in mounting holes on each side of TM172ABKP• (2).
9	Wire the unit according to the wiring procedure.
10	Gently push excess wiring back into hole.
11	Gently snap in place TM172DCLF• into TM172ABKP• (3).

### TM172DCLF• Top Hat Section Rail (DIN Rail) Installation

The TM172DCLF• remote display can be mounted horizontally on a top hat section rail (DIN rail).

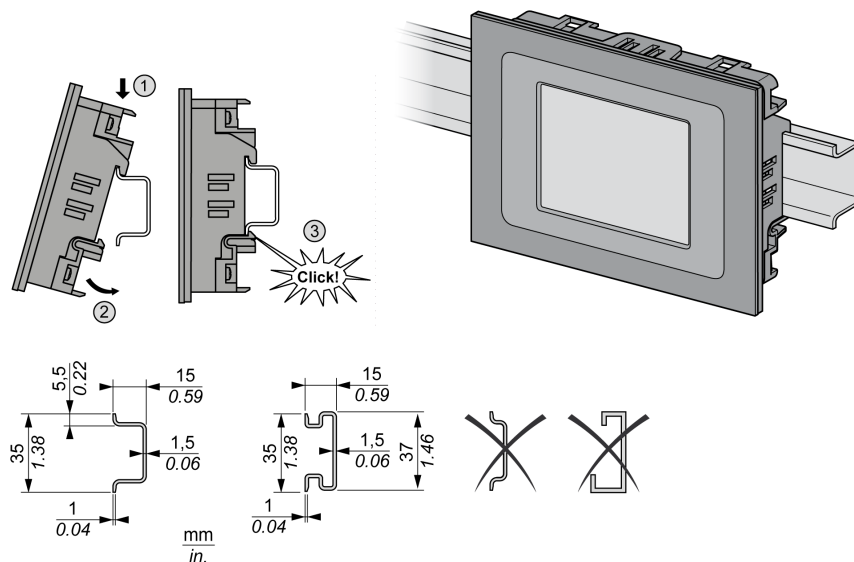

The following procedure describes how to install a TM172DCLF• remote display on a top hat section rail (DIN rail):

Step	Action
1	Wire the unit according to the wiring procedure.
2	Position the top groove of the remote display on the top edge of the Top Hat Section Rail (DIN rail) (1).
3	Press the assembly against the Top Hat Section Rail (DIN rail) (2) up to the locked position (3).

### Mounting Holes Layout

Mounting hole layout for TM172DCLF•:

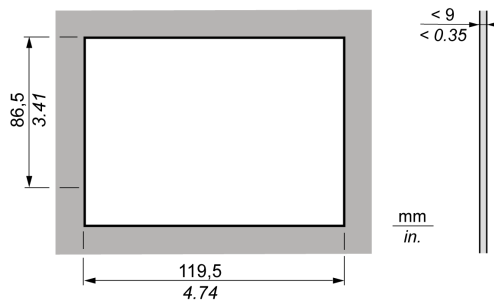

Mounting holes layout for TM172ABKPG or TM172ABKPW:

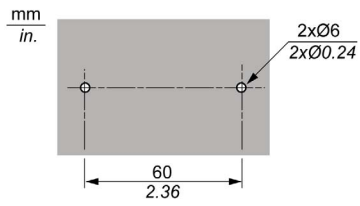



---

# Part III

## Controllers and Expansion Modules

---

### What Is in This Part?

This part contains the following chapters:

Chapter	Chapter Name	Page
5	Environmental Characteristics	51
6	TM172P..... / TM172O..... Controllers Description	53
7	TM172E••R Expansion Modules Description	65
8	Electrical Characteristics and Wiring Diagrams	71
9	User Interface	117



# Chapter 5

## Environmental Characteristics

### Environmental Characteristics

#### Technical Data

The Modicon M172 Logic Controller offer components meet European Community (CE) requirements for open equipment. You must install them in an enclosure or other location designed for the specific environmental conditions and to minimize the possibility of unintended contact with hazardous voltages. Use metal enclosures to improve the electromagnetic immunity of your M172 system. This equipment meets CE requirements as indicated in the following tables.

<b>⚠ WARNING</b>
<b>UNINTENDED EQUIPMENT OPERATION</b>
Do not exceed any of the rated values specified within this chapter.
<b>Failure to follow these instructions can result in death, serious injury, or equipment damage.</b>

#### Controller and Expansion Modules Specifications

Characteristics	Specification											
		TM172P•G07R	TM172P•G18R / TM172O•M18R	TM172PDG18S	TM172O••28R	TM172PBG28RI / TM172PDG28RI	TM172PDG28SI	TM172O••42R	TM172PBG42RI / TM172PDG42RI	TM172PDG42SI	TM172P•G28R / TM172P•G42R	TM172PDG28S / TM172PDG42S
The product complies with the following harmonized Standards	EN 60730-1 / EN 60730-2-9	✓										
Construction of control	Electronic automatic Incorporated Control	✓										
Purpose of control	Operating control (non-safety-related)	✓										
Mounting	Top Hat Section Rail (DIN rail)	✓										
	Optional panel mounting (with accessories)	✓										
Type of action	1.B	✓										
	1.Y	-	✓	-	✓	-	✓	-	✓	-		
Type of disconnection or suspension for each circuit	Micro disconnection	✓										
Pollution degree	2 (normal)	✓										
Over-voltage category	II	✓										
Rated impulse voltage	2500 V	✓										
Period of electric stress on the insulating parts	Long period, EN 60730	✓										

Characteristics	Specification															
		TM172P-G07R	TM172P-G18R / TM172O-M18R	TM172PDG18S	TM172O-28R	TM172PBG28RI / TM172PDG28RI	TM172PDG28SI	TM172O-42R	TM172PBG42RI / TM172PDG42RI	TM172PDG42SI	TM172P-G28R / TM172P-G42R	TM172PDG28S / TM172PDG42S	TM172E12R	TM172E28R		
Power supply	24 Vac (+/- 10 %) 50 Hz / 60 Hz 20...38 Vdc (non-isolated)	-										✓				
	24 Vac (+/- 10 %) 50 Hz / 60 Hz 20...38 Vdc (isolated)	✓										-				
Power Consumption	20 VA / 10 W	✓	-										✓	-		
	21 VA / 11 W	-	✓	-												
	23 VA / 12 W	-		✓	-											
	24 VA / 15 W	-										✓				
	25 VA / 14 W	-										✓	-			
	35 VA / 15 W	-										✓	-			
Insulation class	II	✓														
Ambient operating temperature	-20...55 °C (-4...131 °F)	-	✓	-										✓	-	
	-20...60 °C (-4...140 °F)	✓			✓ (1)	-	✓ (1)	-								
	-20...65 °C (-4...149 °F)	-		✓ (2)	-	✓ (2)	-	✓ (3)	-	✓						
Ambient operating humidity (non-condensing)	5...95 %	✓														
Ambient storage temperature	-30...70 °C (-22...158 °F)	✓														
Ambient storage humidity (non-condensing)	5...95 %	✓														
Temperature for ball pressure test	125 °C (257 °F)	✓										-	✓			
Insulation material group	IIIa	✓														
Fire-resistance category	D	✓														
Software class and structure	A	✓														
Digital outputs	Refer to the label on the device	✓														
Degree of protection by enclosure	IP20	✓														
<p>(1) Limited to 55°C (131°F), if mounted other than horizontally on vertical plane.                  (2) Limited to 60°C (140°F), if mounted other than horizontally on vertical plane.                  (3) Limited to 60°C (140°F), if DO8 is active or if mounted other than horizontally on vertical plane.</p>																

---

# Chapter 6

## TM172P..... / TM172O..... Controllers Description

---

### What Is in This Chapter?

This chapter contains the following topics:

Topic	Page
TM172P•G07R	54
TM172P••18• / TM172O••18•	56
TM172P••28•• / TM172O••28R	59
TM172P••42•• / TM172O••42R	62

## TM172P•G07R

### Overview

Reference	Description
TM172PBG07R	M172 Performance Blind 7 I/Os Isolated
TM172PDG07R	M172 Performance Display 7 I/Os Isolated

### Physical Description

The following illustration presents the TM172P•G07R controller:

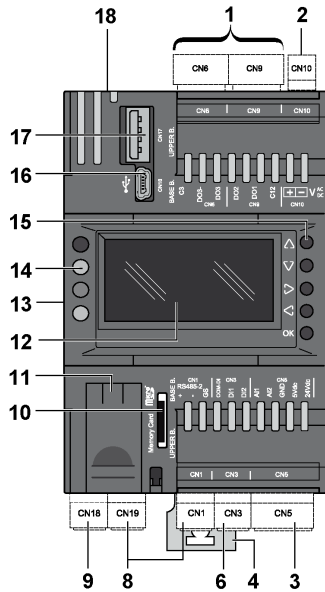

Number	Name	Description
1	CN6	DO3 High voltage relay digital output 250 Vac 3 A SPDT <i>(see page 84)</i>
	CN9	DO1...DO2 High voltage relay digital output 250 Vac 3 A SPST <i>(see page 81)</i>
2	CN10	24 Vac/dc isolated power supply <i>(see page 73)</i>
3	CN5	Power out +24 Vdc power out for analog inputs, max current 100 mA +5 Vdc power out for ratiometric analog inputs, max current 40 mA <sup>(2)</sup>
		AI1...AI2 Analog inputs are configurable as <i>(see page 87)</i> : <ul style="list-style-type: none"> <li>• NTC resistive input or digital input</li> <li>• Current analog input</li> <li>• Voltage analog input</li> <li>• PTC resistive input</li> </ul>
4	-	Clip-on lock <i>(see page 35)</i>
6	CN3	DI1...DI2 Fast digital input, pulse/frequency counter up 2 kHz, opto-isolated <i>(see page 77)</i>
8	CN1	RS-485 serial port-2 <i>(see page 107)</i>
	CN19	RS-485 serial port-1 <i>(see page 107)</i>
9	CN18	CAN expansion bus master <i>(see page 104)</i>
10	-	Micro SD memory card slot <i>(see page 113)</i>
11	-	Service battery door <i>(see page 115)</i>
12	-	User interface - Display <i>(see page 117)</i> <sup>(1)</sup>
13	-	Communication module connector <i>(see page 20)</i>
14	-	User interface - LEDs <i>(see page 117)</i> <sup>(1)</sup>
15	-	User interface - Keys <i>(see page 117)</i> <sup>(1)</sup>
16	CN16	USB type Mini-B female for PC connection <i>(see page 109)</i>

**(1)** Only for TM172•D.....  
**(2)** 0-5 V Ratiometric: ratiometric range is 0.5 V to 4.5 V. Maximum current at +5 Vdc is 40 mA.

Number	Name	Description
17	CN17	USB type A female for a mass storage device (FAT32) <i>(see page 109)</i>
18	CN20	Ethernet Modbus TCP/IP or BACnet IP <i>(see page 110)</i>

(1) Only for TM172-D.....  
 (2) 0-5 V Ratiometric: ratiometric range is 0.5 V to 4.5 V. Maximum current at +5 Vdc is 40 mA.

**NOTE:** The controller is delivered without removable screw terminal blocks *(see page 23)*.

## NOTICE

### INOPERABLE EQUIPMENT

Configure the analog inputs and outputs, and related parameters, according to the physical types of resources connected.

**Failure to follow these instructions can result in equipment damage.**

For more details, refer to analog inputs configuration *(see page 87)* and analog outputs configuration *(see page 98)*.

For more information about the wiring, refer to wiring best practices *(see page 29)*.

### Dimension

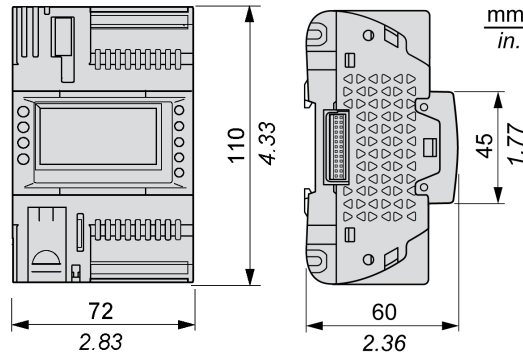

### Mounting Holes Layout

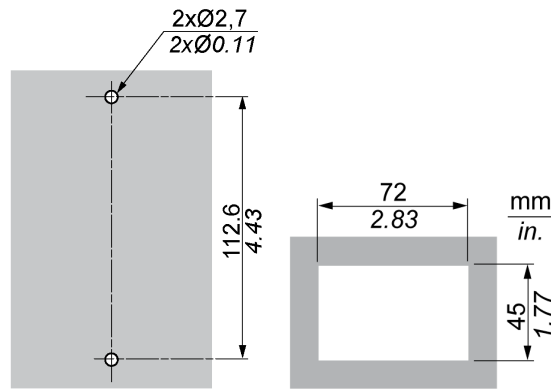

## TM172P..18. / TM172O..18.

### Overview

Reference	Description
TM172PBG18R	M172 Performance Blind 18 I/Os Isolated
TM172PDG18R	M172 Performance Display 18 I/Os Isolated
TM172PDG18S	M172 Performance Display 18 I/Os 2 SSR Isolated
TM172OBM18R	M172 Optimized Blind 18 I/Os Isolated
TM172ODM18R	M172 Optimized Display 18 I/Os Isolated

### Physical Description

The following illustration presents the TM172...18. controller:

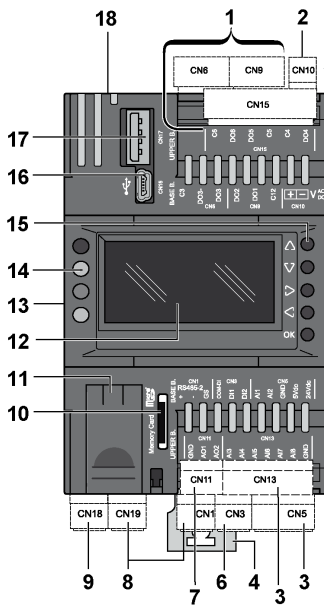

Number	Name	Description
1	CN6	DO3 High voltage relay digital output 250 Vac 3 A SPDT ( <i>see page 84</i> )
	CN9	DO1...DO2 High voltage relay digital output 250 Vac 3 A SPST ( <i>see page 81</i> )
	CN15	DO4...DO5 <ul style="list-style-type: none"> <li>TM172.....R.: High voltage relay digital output 250 Vac 3 A SPST (<i>see page 81</i>)</li> <li>TM172PDG18S: High voltage SSR digital output 240 Vac 0.2 A (<i>see page 83</i>)</li> </ul>
	DO6	High voltage relay digital output 250 Vac 3 A SPST ( <i>see page 81</i> )
2	CN10	24 Vac/dc isolated power supply ( <i>see page 73</i> )
3	CN5	Power out <ul style="list-style-type: none"> <li>+24 Vdc power out for analog inputs, max current 100 mA</li> <li>+5 Vdc power out for ratiometric analog inputs, max current 40 mA <sup>(2)</sup></li> </ul>
	CN13	AI1...AI2 <ul style="list-style-type: none"> <li>Analog inputs are configurable as (<i>see page 87</i>):                             <ul style="list-style-type: none"> <li>NTC resistive input or digital input</li> <li>Current analog input</li> <li>Voltage analog input</li> <li>PTC resistive input</li> </ul> </li> </ul>
4	-	Clip-on lock ( <i>see page 35</i> )
6	CN3	DI1...DI2 Fast digital input, pulse/frequency counter up 2 kHz, opto-isolated ( <i>see page 77</i> )
<p>(1) Only for TM172-D......</p> <p>(2) 0-5 V Ratiometric: ratiometric range is 0.5 V to 4.5 V. Maximum current at +5 Vdc is 40 mA.</p> <p>(3) Only for TM172P......</p>		



Number	Name	Description
7	CN11	AO1...AO2 Low voltage SELV analog outputs, configurable as <i>(see page 98)</i> : <ul style="list-style-type: none"> <li>● Current modulation analog output</li> <li>● Current ON/OFF analog output</li> <li>● Voltage modulation analog output</li> <li>● PWM open collector</li> </ul>
8	CN1	RS-485 serial port-2 <i>(see page 107)</i>
	CN19	RS-485 serial port-1 <i>(see page 107)</i>
9	CN18	CAN expansion bus master <i>(see page 104)</i>
10	-	Micro SD memory card slot <i>(see page 113)</i> <sup>(3)</sup>
11	-	Service battery door <i>(see page 115)</i>
12	-	User interface - Display <i>(see page 117)</i> <sup>(1)</sup>
13	-	Communication module connector <i>(see page 20)</i>
14	-	User interface - LEDs <i>(see page 117)</i> <sup>(1)</sup>
15	-	User interface - Keys <i>(see page 117)</i> <sup>(1)</sup>
16	CN16	USB type Mini-B female for PC connection <i>(see page 109)</i>
17	CN17	USB type A female for a mass storage device (FAT32) <i>(see page 109)</i> <sup>(3)</sup>
18	CN20	Ethernet Modbus TCP/IP or BACnet IP <i>(see page 110)</i> <sup>(3)</sup>

(1) Only for TM172-D.....  
 (2) 0-5 V Ratiometric: ratiometric range is 0.5 V to 4.5 V. Maximum current at +5 Vdc is 40 mA.  
 (3) Only for TM172P.....

**NOTE:** The controller is delivered without removable screw terminal blocks *(see page 23)*.

*NOTICE*

**INOPERABLE EQUIPMENT**

Configure the analog inputs and outputs, and related parameters, according to the physical types of resources connected.

**Failure to follow these instructions can result in equipment damage.**

For more details, refer to analog inputs configuration *(see page 87)* and analog outputs configuration *(see page 98)*.

For more information about the wiring, refer to wiring best practices *(see page 29)*.

**Dimension**

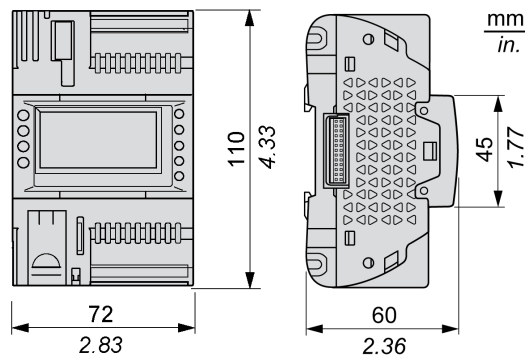

### Mounting Holes Layout

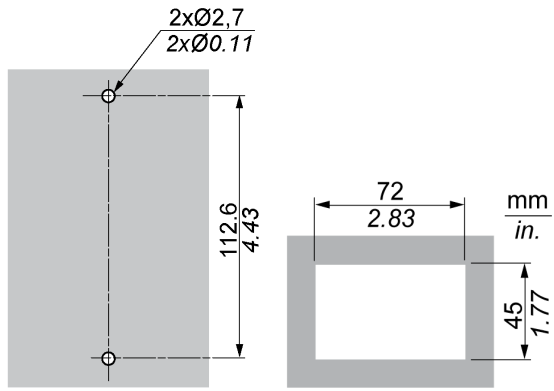

## TM172P••28•• / TM172O••28R

### Overview

Reference	Description
TM172PBG28R	M172 Performance Blind 28 I/Os
TM172PBG28RI	M172 Performance Blind 28 I/Os Isolated
TM172PDG28R	M172 Performance Display 28 I/Os
TM172PDG28RI	M172 Performance Display 28 I/Os Isolated
TM172PDG28S	M172 Performance Display 28 I/Os 2 SSR
TM172PDG28SI	M172 Performance Display 28 I/Os 2 SSR Isolated
TM172OBM28R	M172 Optimized Blind 28 I/Os Isolated
TM172ODM28R	M172 Optimized Display 28 I/Os Isolated

### Physical Description

The following illustration presents the TM172P••28•• controller:

TM172P••28•• controller:

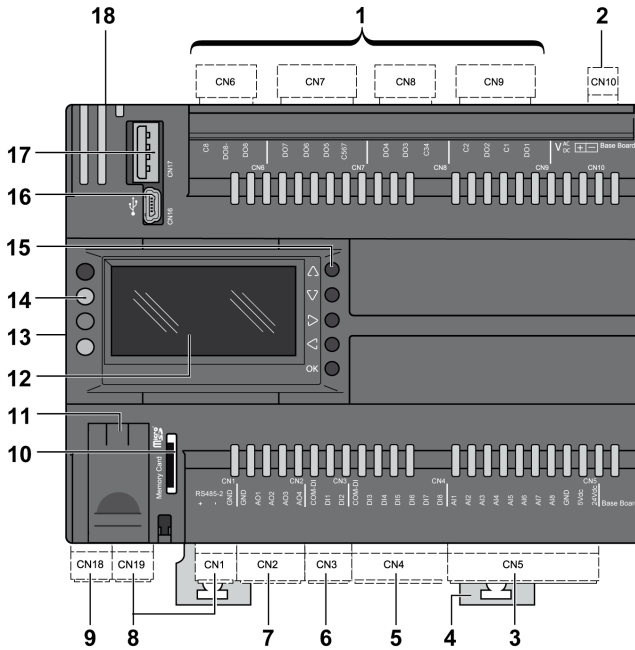

TM172P••28••I / TM172O••28R controller:

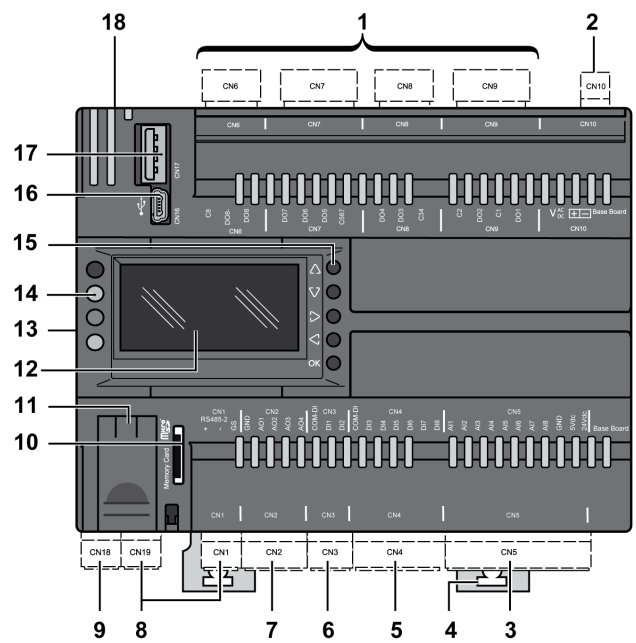

Number	Name	Description	
1	CN6	DO8 <ul style="list-style-type: none"> <li>TM172P••28••: High voltage relay digital output 250 Vac 1 A SPDT (<i>see page 84</i>)</li> <li>TM172P••28••I / TM172O••28R: High voltage relay digital output 250 Vac 3 A SPDT (<i>see page 84</i>)</li> </ul>	
	CN7	DO5...DO7	High voltage relay digital output 250 Vac 3 A SPST ( <i>see page 81</i> )
	CN8	DO3...DO4	
	CN9	DO1...DO2	<ul style="list-style-type: none"> <li>TM172•••••R•: High voltage relay digital output 250 Vac 3 A SPST (<i>see page 81</i>)</li> <li>TM172•••••S•: High voltage SSR digital output 240 Vac 0.5 A (<i>see page 83</i>)</li> </ul>
2	CN10	24 Vac/dc power supply ( <i>see page 73</i> )	

(1) Only for TM172•D•••••.  
 (2) 0-5 V Ratiometric: ratiometric range is 0.5 V to 4.5 V. Maximum current at +5 Vdc is 50 mA.  
 (3) Only for TM172P••••••.

Number	Name	Description	
3	CN5	Power out	+24 Vdc power out for analog inputs, max current 150 mA +5 Vdc power out for ratiometric analog inputs, max current 50 mA <sup>(2)</sup>
		AI1...AI8	Analog inputs are configurable as <a href="#">(see page 87)</a> : <ul style="list-style-type: none"> <li>● NTC resistive input or digital input</li> <li>● Current analog input</li> <li>● Voltage analog input</li> <li>● PTC resistive input</li> </ul>
4	-	Clip-on lock <a href="#">(see page 35)</a>	
5	CN4	DI3...DI8	Regular digital input opto-isolated <a href="#">(see page 78)</a>
6	CN3	DI1...DI2	Fast digital input, pulse/frequency counter up 2 kHz, opto-isolated <a href="#">(see page 77)</a>
7	CN2	AO1...AO2	Low voltage (SELV) analog outputs 0...10 Vdc <a href="#">(see page 100)</a>
		AO3...AO4	Low voltage SELV analog outputs, configurable as <a href="#">(see page 98)</a> : <ul style="list-style-type: none"> <li>● Current modulation analog output</li> <li>● Current ON/OFF analog output</li> <li>● Voltage modulation analog output</li> <li>● PWM open collector</li> </ul>
8	CN1	RS-485 serial port-2 <a href="#">(see page 107)</a>	
	CN19	RS-485 serial port-1 <a href="#">(see page 107)</a>	
9	CN18	CAN expansion bus master <a href="#">(see page 104)</a>	
10	-	Micro SD memory card slot <a href="#">(see page 113)</a> <sup>(3)</sup>	
11	-	Service battery door <a href="#">(see page 115)</a>	
12	-	User interface - Display <a href="#">(see page 117)</a> <sup>(1)</sup>	
13	-	Communication module connector <a href="#">(see page 20)</a>	
14	-	User interface - LEDs <a href="#">(see page 117)</a> <sup>(1)</sup>	
15	-	User interface - Keys <a href="#">(see page 117)</a> <sup>(1)</sup>	
16	CN16	USB type Mini-B female for PC connection <a href="#">(see page 109)</a>	
17	CN17	USB type A female for a mass storage device (FAT32) <a href="#">(see page 109)</a> <sup>(3)</sup>	
18	CN20	Ethernet Modbus TCP/IP or BACnet IP <a href="#">(see page 110)</a> <sup>(3)</sup>	

**(1)** Only for TM172•D.....  
**(2)** 0-5 V Ratiometric: ratiometric range is 0.5 V to 4.5 V. Maximum current at +5 Vdc is 50 mA.  
**(3)** Only for TM172P.....

**NOTE:** The controller is delivered without removable screw terminal blocks [\(see page 23\)](#).

## **NOTICE**

### **INOPERABLE EQUIPMENT**

Configure the analog inputs and outputs, and related parameters, according to the physical types of resources connected.

**Failure to follow these instructions can result in equipment damage.**

For more details, refer to analog inputs configuration [\(see page 87\)](#) and analog outputs configuration [\(see page 98\)](#).

For more information about the wiring, refer to wiring best practices [\(see page 29\)](#).

Dimension

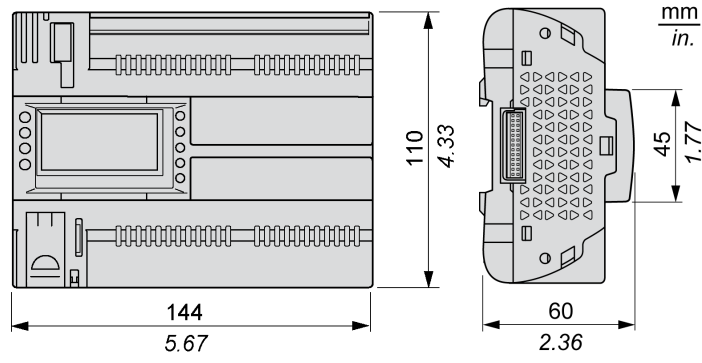

Mounting Holes Layout

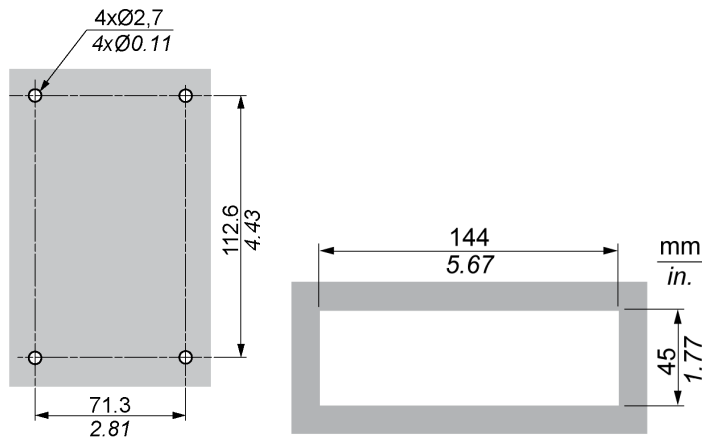

## TM172P••42•• / TM172O••42R

### Overview

Reference	Description
TM172PBG42R	M172 Performance Blind 42 I/Os
TM172PBG42RI	M172 Performance Blind 42 I/Os Isolated
TM172PDG42R	M172 Performance Display 42 I/Os
TM172PDG42RI	M172 Performance Display 42 I/Os Isolated
TM172PDG42S	M172 Performance Display 42 I/Os 2 SSR
TM172PDG42SI	M172 Performance Display 42 I/Os 2 SSR Isolated
TM172OBM42R	M172 Optimized Blind 42 I/Os Isolated
TM172ODM42R	M172 Optimized Display 42 I/Os Isolated

### Physical Description

The following illustration presents the TM172••42•• controller:

TM172P••42• controller:

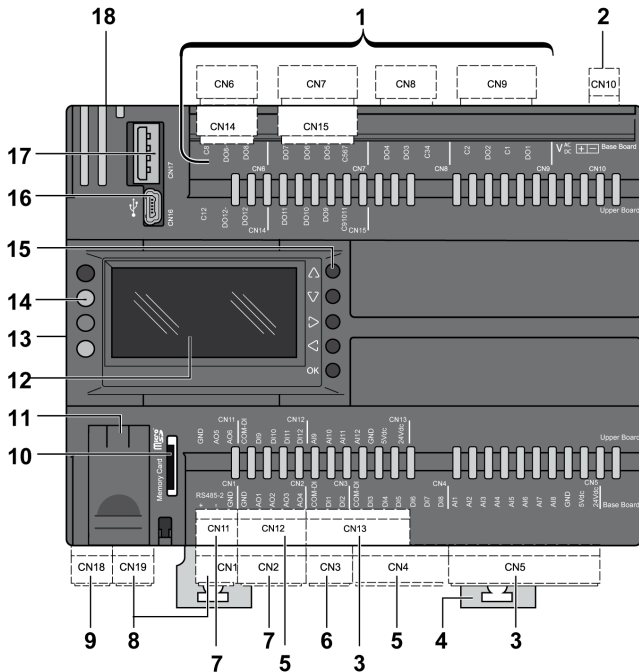

TM172P••42•I / TM172O••42R controller:

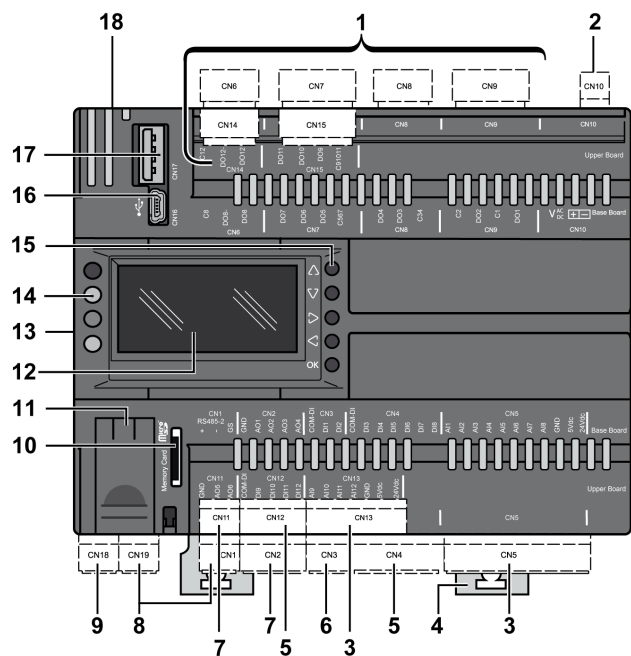

Number	Name	Description
1	CN6	DO8 <ul style="list-style-type: none"> <li>● TM172P**42*: High voltage relay digital output 250 Vac 1 A SPDT (<i>see page 84</i>)</li> <li>● TM172P**42*I / TM172O**42R: High voltage relay digital output 250 Vac 3 A SPDT (<i>see page 84</i>)</li> </ul>
	CN7	DO5...DO7 High voltage relay digital output 250 Vac 3 A SPST ( <i>see page 81</i> )
	CN8	DO3...DO4
	CN9	DO1...DO2 <ul style="list-style-type: none"> <li>● TM172*****R*: High voltage relay digital output 250 Vac 3 A SPST (<i>see page 81</i>)</li> <li>● TM172*****S*: High voltage SSR digital output 240 Vac 0.5 A (<i>see page 83</i>)</li> </ul>
	CN14	DO12 <ul style="list-style-type: none"> <li>● TM172P**42*: High voltage relay digital output 250 Vac 1 A SPDT (<i>see page 84</i>)</li> <li>● TM172P**42*I / TM172O**42R: High voltage relay digital output 250 Vac 3 A SPDT (<i>see page 84</i>)</li> </ul>
	CN15	DO9...DO11 High voltage relay digital output 250 Vac 3 A SPST ( <i>see page 81</i> )
2	CN10	24 Vac/dc power supply ( <i>see page 73</i> )
3	CN5	Power out +24 Vdc power out for analog inputs, max current 150 mA <sup>(3)</sup> +5 Vdc power out for ratiometric analog inputs, max current 50 mA <sup>(2)(3)</sup>
		A11...A18 Analog inputs are configurable as ( <i>see page 87</i> ): <ul style="list-style-type: none"> <li>● NTC resistive input or digital input</li> <li>● Current analog input</li> <li>● Voltage analog input</li> <li>● PTC resistive input</li> </ul>
	CN13	A19...A12 Identical to CN5. Power out
4	-	Clip-on lock ( <i>see page 35</i> )
5	CN4	DI3...DI8 Regular digital input opto-isolated ( <i>see page 78</i> )
	CN12	DI9...DI12
6	CN3	DI1...DI2 Fast digital input, pulse/frequency counter up 2 kHz, opto-isolated ( <i>see page 77</i> )
7	CN2	AO1...AO2 Low voltage (SELV) analog outputs 0...10 Vdc ( <i>see page 100</i> )
		AO3...AO4 Low voltage SELV analog outputs, configurable as ( <i>see page 98</i> ): <ul style="list-style-type: none"> <li>● Current modulation analog output</li> <li>● Current ON/OFF analog output</li> <li>● Voltage modulation analog output</li> <li>● PWM open collector</li> </ul>
	CN11	AO5...AO6 Low voltage (SELV) analog outputs 0...10 Vdc ( <i>see page 100</i> )
8	CN1	RS-485 serial port-2 ( <i>see page 107</i> )
	CN19	RS-485 serial port-1 ( <i>see page 107</i> )
9	CN18	CAN expansion bus master ( <i>see page 104</i> )
10	-	Micro SD memory card slot ( <i>see page 113</i> ) <sup>(4)</sup>
11	-	Service battery door ( <i>see page 115</i> )
12	-	User interface - Display ( <i>see page 117</i> ) <sup>(1)</sup>
13	-	Communication module connector ( <i>see page 20</i> )
14	-	User interface - LEDs ( <i>see page 117</i> ) <sup>(1)</sup>
15	-	User interface - Keys ( <i>see page 117</i> ) <sup>(1)</sup>
16	CN16	USB type Mini-B female for PC connection ( <i>see page 109</i> )
17	CN17	USB type A female for a mass storage device (FAT32) ( <i>see page 109</i> ) <sup>(4)</sup>
18	CN20	Ethernet Modbus TCP/IP or BACnet IP ( <i>see page 110</i> ) <sup>(4)</sup>
<p>(1) Only for TM172-D.....                      (2) 0-5 V Ratiometric: ratiometric range is 0.5 V to 4.5 V. Maximum current at +5 Vdc is 50 mA.                      (3) The maximum current value is the sum between the maximum currents supplied by the corresponding terminals in the CN5 connector and in the CN13 connector.                      (4) Only for TM172P.....</p>		

**NOTE:** The controller is delivered without removable screw terminal blocks (*see page 23*).

## **NOTICE**

### **INOPERABLE EQUIPMENT**

Configure the analog inputs and outputs, and related parameters, according to the physical types of resources connected.

**Failure to follow these instructions can result in equipment damage.**

For more details, refer to analog inputs configuration (*see page 87*) and analog outputs configuration (*see page 98*).

For more information about the wiring, refer to wiring best practices (*see page 29*).

### Dimension

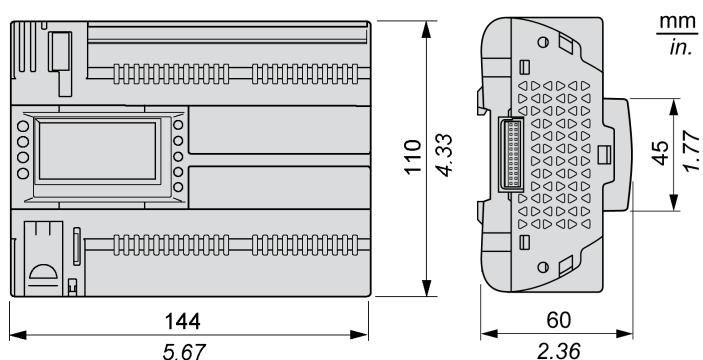

### Mounting Holes Layout

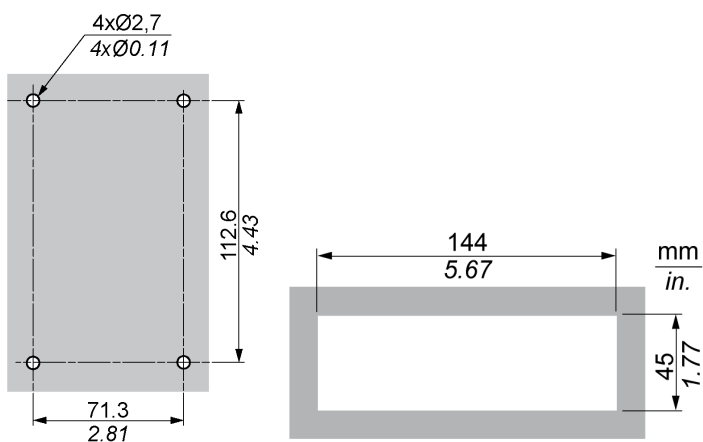



---

# Chapter 7

## TM172E••R Expansion Modules Description

---

### What Is in This Chapter?

This chapter contains the following topics:

Topic	Page
TM172E12R	66
TM172E28R	68

## TM172E12R

### Physical Description

The following illustration presents the TM172E12R expansion module:

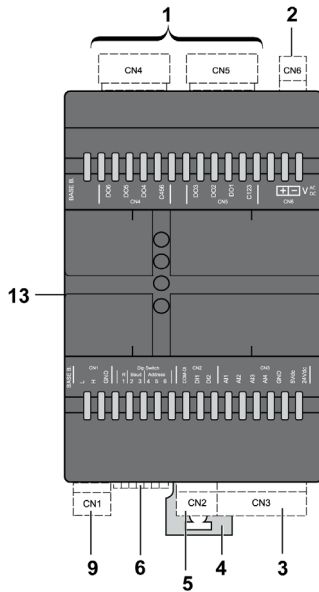

Number	Name	Description	
1	CN4	DO4...DO6	High voltage relay digital output 250 Vac 3 A SPST ( <i>see page 81</i> )
	CN5	DO1...DO3	
2	CN6	24 Vac/dc non-isolated power supply ( <i>see page 73</i> )	
3	CN3	Power out	+24 Vdc power out for analog inputs, max current 125 mA +5 Vdc power out for ratiometric analog inputs, max current 50 mA <sup>(1)</sup>
		AI1...AI4	Analog inputs are configurable as ( <i>see page 87</i> ): <ul style="list-style-type: none"> <li>● NTC resistive input or digital input</li> <li>● Current analog input</li> <li>● Voltage analog input</li> <li>● PTC resistive input</li> </ul>
4	-	Clip-on lock ( <i>see page 35</i> )	
5	CN2	DI1...DI2	Fast digital input, pulse/frequency counter up 2 kHz, opto-isolated ( <i>see page 77</i> )
6	-	CAN configuration 6-position DIP switches ( <i>see page 104</i> )	
9	CN1	CAN expansion bus slave ( <i>see page 104</i> )	
13	-	TTL Port (Service only)	

**(1)** 0-5 V Ratiometric: ratiometric range is 0.5 V to 4.5 V. Maximum current at +5 Vdc is 50 mA.

**NOTE:** The expansion module is delivered without removable screw terminal blocks (*see page 23*).

## **NOTICE**

### **INOPERABLE EQUIPMENT**

Configure the analog inputs and outputs, and related parameters, according to the physical types of resources connected.

**Failure to follow these instructions can result in equipment damage.**

For more details, refer to analog inputs configuration (*see page 87*) and analog outputs configuration (*see page 98*).

For more information about the wiring, refer to wiring best practices (*see page 29*).

Dimension

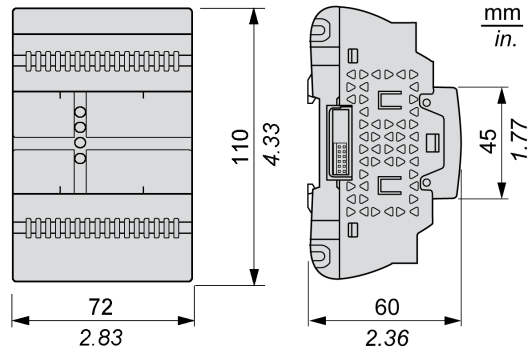

Mounting Holes Layout

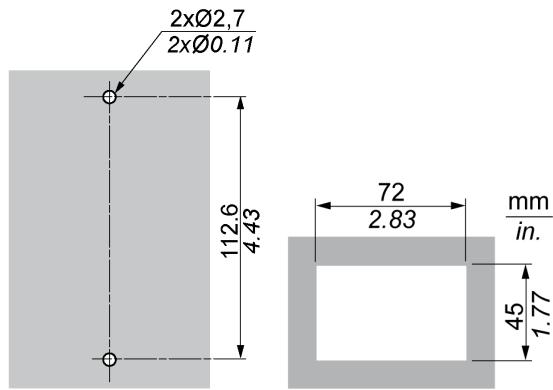

## TM172E28R

### Physical Description

The following illustration presents the TM172E28R expansion module:

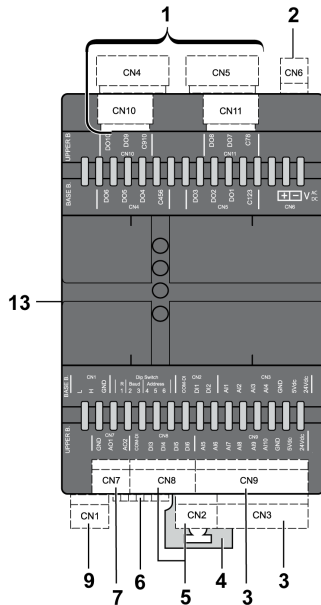

Number	Name	Description	
1	CN4	DO4...DO6	High voltage relay digital output 250 Vac 3 A SPST ( <i>see page 81</i> )
	CN5	DO1...DO3	
	CN10	DO9...DO10	
	CN11	DO7...DO8	
2	CN6	24 Vac/dc non-isolated power supply ( <i>see page 73</i> )	
3	CN3	Power out	+24 Vdc power out for analog inputs, max current 125 mA <sup>(2)</sup> +5 Vdc power out for ratiometric analog inputs, max current 50 mA <sup>(1)(2)</sup>
		AI1...AI4	Analog inputs are configurable as ( <i>see page 87</i> ): <ul style="list-style-type: none"> <li>● NTC resistive input or digital input</li> <li>● Current analog input</li> <li>● Voltage analog input</li> <li>● PTC resistive input</li> </ul>
	CN9	AI5...AI10	Identical to CN3.
4	-	Clip-on lock ( <i>see page 35</i> )	
5	CN2	DI1...DI2	Fast digital input, pulse/frequency counter up 2 kHz, opto-isolated ( <i>see page 77</i> )
	CN8	DI3...DI6	Regular digital input opto-isolated ( <i>see page 78</i> )
6	-	CAN configuration 6-position DIP switches ( <i>see page 104</i> )	
7	CN7	AO1...AO2	Low voltage SELV analog outputs, configurable as ( <i>see page 98</i> ): <ul style="list-style-type: none"> <li>● Current modulation analog output</li> <li>● Current ON/OFF analog output</li> <li>● Voltage modulation analog output</li> <li>● PWM open collector</li> </ul>
9	CN1	CAN expansion bus slave ( <i>see page 104</i> )	
13	-	TTL Port (Service only)	

(1) 0-5 V Ratiometric: ratiometric range is 0.5 V to 4.5 V. Maximum current at +5 Vdc is 50 mA.  
(2) The maximum current value is the sum between the maximum currents supplied by the corresponding terminals in the CN3 connector and in the CN9 connector.

**NOTE:** The expansion module is delivered without removable screw terminal blocks (*see page 23*).

<b><i>NOTICE</i></b>
<p><b>INOPERABLE EQUIPMENT</b></p> <p>Configure the analog inputs and outputs, and related parameters, according to the physical types of resources connected.</p> <p><b>Failure to follow these instructions can result in equipment damage.</b></p>

For more details, refer to analog inputs configuration (*see page 87*) and analog outputs configuration (*see page 98*).

For more information about the wiring, refer to wiring best practices (*see page 29*).

**Dimension**

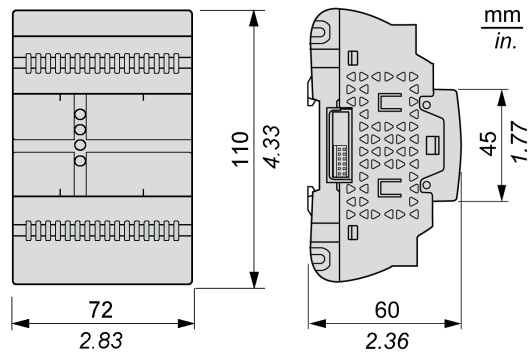

**Mounting Holes Layout**

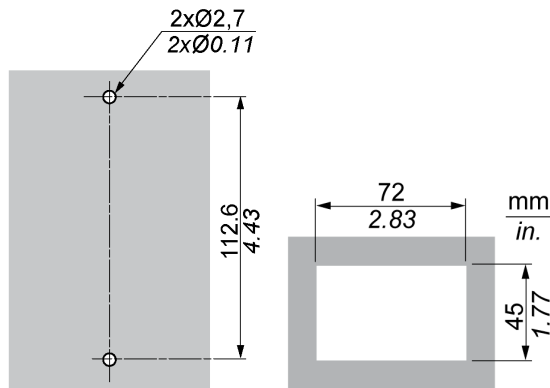



# Chapter 8

## Electrical Characteristics and Wiring Diagrams

From time to time, new input modules, output modules, or other devices are made available that are not documented in the present documentation. For information on new devices, contact your local Schneider Electric representative.

### ***NOTICE***

#### **INOPERABLE EQUIPMENT**

Update the controller firmware to the latest version every time you install a newly released Input/Output expansion module or other device to this equipment.

**Failure to follow these instructions can result in equipment damage.**

**NOTE:** For more information on how to update the controller firmware, contact your local Schneider Electric representative.

Applying incorrect current or voltage levels on TM172P••07• / TM172P••18• / TM172O••18• / TM172P••28•I / TM172O••28R / TM172P••42•I / TM172O••42R controllers and TM172E••R expansion modules inputs and outputs could damage the electronic circuitry. Further, connecting a current input device to an analog input configured for voltage, and vice versa, could damage the electronic circuitry.

### ***NOTICE***

#### **INOPERABLE EQUIPMENT**

- Do not apply current above 30 mA to the analog inputs of the expansion module.
- Do not apply voltages above 24 Vdc and less than -7 Vdc to the analog inputs of the expansion module.
- Do not mismatch the applied signal with the analog input configuration.

**Failure to follow these instructions can result in equipment damage.**

Applying incorrect current or voltage levels on TM172P••28•• / TM172P••42•• controllers analog inputs and outputs could damage the electronic circuitry. Further, connecting a current input device to an analog input configured for voltage, and vice versa, could damage the electronic circuitry.

### ***NOTICE***

#### **INOPERABLE EQUIPMENT**

- Do not apply current above 25 mA to the analog inputs of the controller or Input/Output expansion module.
- Do not apply voltages above 11 Vdc to the analog inputs of the controller or Input/Output expansion module.
- Do not mismatch the applied signal with the analog input configuration.

**Failure to follow these instructions can result in equipment damage.**

### What Is in This Chapter?

This chapter contains the following sections:

Section	Topic	Page
8.1	Power Supply	73
8.2	Digital Input	76
8.3	Digital Output	80
8.4	Analog Inputs	86
8.5	Analog Outputs	97
8.6	Communication	103

<b>Section</b>	<b>Topic</b>	<b>Page</b>
8.7	Memory	113
8.8	RTC (Real-Time Clock)	115



## Section 8.1

### Power Supply

#### Power Supply

#### Controllers and Expansion Modules Power Supply

References	Power supply characteristics		Maximum power consumption
TM172P•G07R controller	Isolated	24 Vac (+/- 10 %) - 50/60 Hz	20 VA
		20...38 Vdc	10 W
TM172P•G18• / TM172O•M18R controllers		24 Vac (+/- 10 %) - 50/60 Hz	21 VA
		20...38 Vdc	11 W
TM172P••28•I / TM172O••28R controllers	Non-isolated	24 Vac (+/- 10 %) - 50/60 Hz	23 VA
		20...38 Vdc	12 W
TM172P••42•I / TM172O••42R controllers		24 Vac (+/- 10 %) - 50/60 Hz	25 VA
		20...38 Vdc	14 W
TM172P••28• / TM172P••42• controllers	Non-isolated	24 Vac (+/- 10 %) - 50/60 Hz	35 VA
		20...38 Vdc	15 W
TM172E12R expansion module		24 Vac (+/- 10 %) - 50/60 Hz	20 VA
		20...38 Vdc	10 W
TM172E28R expansion module	Non-isolated	24 Vac (+/- 10 %) - 50/60 Hz	24 VA
		20...38 Vdc	15 W

Power supply wiring diagram:

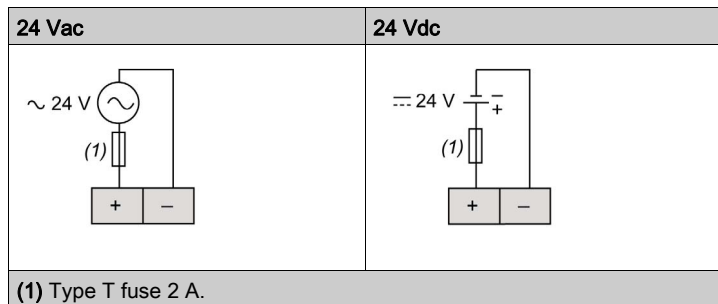

Pitch of the terminal block	Cabling length
3.50 mm (0.14 in.)	10 m (32.8 ft)

### ***NOTICE***

#### **INOPERABLE EQUIPMENT**

Do not connect a power cable longer than 10 m (32.8 ft).

**Failure to follow these instructions can result in equipment damage.**

For more information about the wiring, refer to Best wiring practices ([see page 29](#)).

The power supplies for the TM172P....., TM172O....., and TM172E..R must be rated Safety Extra Low Voltage (SELV) according to IEC 61140. These sources of power are isolated between the electrical input and output circuits of the power supply as well as simple separation from ground (earth), PELV, and other SELV systems.

**⚠ DANGER**

**GROUND LOOP CAUSING ELECTRIC SHOCK AND/OR INOPERABLE EQUIPMENT**

- Do not connect the 0 V power supply/transformer connection supplying this equipment to any external ground (earth) connection.
- Do not connect any 0 V or ground (earth) of the sensors and actuators connected to this equipment to any external ground connection.
- If necessary, use separate power supplies/transformers to power sensors or actuators isolated from this equipment.

**Failure to follow these instructions will result in death or serious injury.**

In all cases, if the specified voltage range is not maintained, the products may not function as intended. Use appropriate safety interlocks and voltage monitoring circuits.

**⚠ WARNING**

**POTENTIAL OF OVERHEATING AND FIRE**

- Do not connect the equipment directly to line voltage.
- Use only isolating SELV, Class 2 power supplies / transformers to supply power to this equipment.

**Failure to follow these instructions can result in death, serious injury, or equipment damage.**

**Power Supply and Field bus Wiring Restriction For Non Isolated Controllers and Expansion Modules**

TM172P..28• / TM172P..42• / TM172E..R power supply inputs are not isolated. If you connect the GND connection of the RS-485 network or the CAN expansion bus across multiple controllers, you must use separate, isolated power supplies. Alternatively, if you are interconnecting the equipment to a single power supply, do not connect the RS-485 or CAN GND signal. Pay special attention when connecting serial lines. Miswiring may lead to inoperable equipment.

CAN network example with separate power lines:

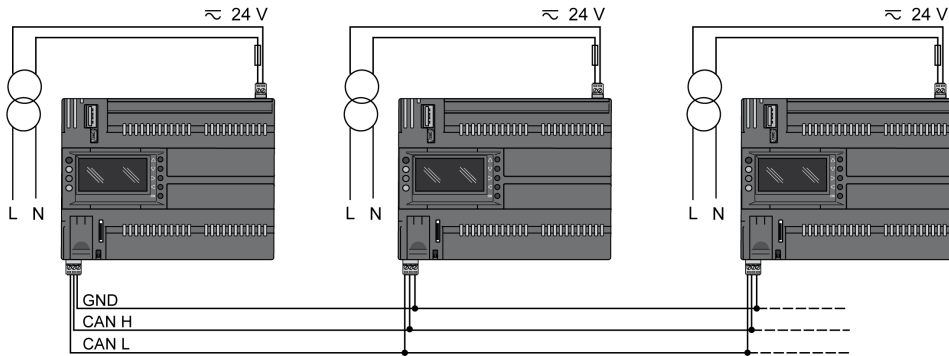

CAN network example with common power line and GND signal not connected:

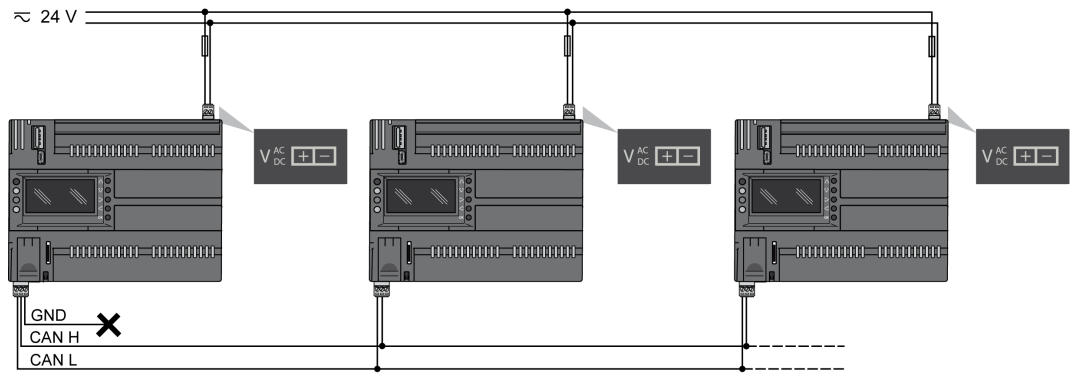

**NOTE:** TM172P•G07R / TM172•••18• / TM172O••28R / TM172O••42R / TM172P••28•I / TM172P••42•I power supply inputs are isolated. GS connection of the RS-485 network or the GND connection of the CAN expansion bus across multiple controllers must be connected regardless of the power supply type and wiring.

## Section 8.2

### Digital Input

#### Digital Inputs

This table presents the digital inputs of controllers and expansion modules:

Description	TM172P-G07R	TM172...18R	TM172...18S	TM172...28R•	TM172...28S•	TM172...42R•	TM172...42S•	TM172E12R	TM172E28R
Fast digital inputs <i>(see page 77)</i>	2	2	2	2	2	2	2	2	2
Regular digital inputs <i>(see page 78)</i>	-	-	-	6	6	10	10	-	4

These devices have analog inputs that can be configured as dry contact digital inputs. For more details, refer to the configuration of analog inputs *(see page 87)*.

**NOTE:** The commons COM\_DI are not internally connected together.

#### What Is in This Section?

This section contains the following topics:

Topic	Page
Fast Digital Inputs	77
Regular Digital Inputs	78

## Fast Digital Inputs

### Overview

If fast digital inputs are used as regular digital inputs, refer to regular digital inputs wiring diagram (*see page 78*).

### Characteristics

The table indicates the digital inputs characteristics:

Characteristic	Value	
	Used as fast input	Used as regular input
Type	Digital input	
Power draw (maximum)	5 mA	
Working voltage	+0...38 Vdc	+0...38 Vdc 0...24 Vac +/-10 % 50/60 Hz
Pulse detection minimum length	Positive pulse 0.15 ms	Positive or negative pulse: <ul style="list-style-type: none"> <li>● TM172P**07* / TM172***18*: 40 ms</li> <li>● TM172***28** / TM172***42** : 20 ms</li> <li>● TM172E28R: 40 ms</li> </ul>
Maximum frequency measurement	2 kHz	-
Logic type	Digital inputs work in positive logic	Digital inputs work in positive or negative logic
Level 1	+20...38 Vdc	+20...38 Vdc 24 Vac +/-10 % 50/60 Hz
Level 0	+0...4 Vdc	+0...4 Vdc 0...3 Vac 50/60 Hz

Logic type description

Logic type	Active state
Positive logic	Output supplies current (source output) Current flows to the input (sink input)
Negative logic	Output draws current (sink output) Current flows from the input (source input)

### Wiring Diagram Example

TM172\*\*\*07\* / TM172\*\*\*18\* / TM172\*\*\*28\*\* / TM172\*\*\*42\*\* (CN3) fast digital input:

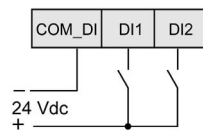

Pitch of the terminal block	Cabling length
3.50 mm (0.14 in)	10 m (32.808 ft)

For more information about the wiring, refer to Best wiring practices (*see page 29*).

### Related Devices and Connectors

The table indicates the related devices and connectors

Related Device	Connector	Label	Description
TM172***07* TM172***18* TM172***28** TM172***42**	CN3	COM-DI	Common for digital inputs 1...2
		DI1...DI2	Regular digital inputs 1...2
TM172E**R	CN2		

## Regular Digital Inputs

### Characteristics

The table indicates the digital inputs characteristics:

Characteristic	Value
Type	Digital input
Power draw (maximum)	5 mA
Working voltage	+0...38 Vdc 0...24 Vac +/-10 % 50/60 Hz
Pulse detection minimum length	<ul style="list-style-type: none"> <li>● TM172...28**/TM172...42** positive or negative pulse                             <ul style="list-style-type: none"> <li>○ DI3...DI4: 20 ms</li> <li>○ DI5...DI8: 40 ms</li> </ul> </li> <li>● TM172...42** positive or negative pulse                             <ul style="list-style-type: none"> <li>○ DI9...DI12: 40 ms</li> </ul> </li> <li>● TM172E28R positive pulse                             <ul style="list-style-type: none"> <li>○ DI3...DI6: 40 ms</li> </ul> </li> </ul>
Logic type	Digital inputs work in positive logic <ul style="list-style-type: none"> <li>● TM172...28**/TM172...42**: Digital inputs work in positive or negative logic</li> <li>● TM172E28R: Digital inputs work in positive logic</li> </ul>
Level 1	+20...38 Vdc 24 Vac +/-10 % 50/60 Hz
Level 0	+0...4 Vdc 0...3 Vac 50/60 Hz

Logic type description

Logic type	Active state
Positive logic	Output supplies current (source output) Current flows to the input (sink input)
Negative logic	Output draws current (sink output) Current flows from the input (source input)

### Wiring Diagram Example

TM172...28\*\* / TM172...42\*\* (CN4) regular digital input:

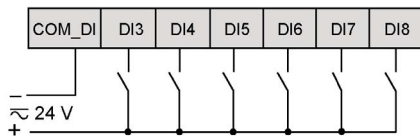

Pitch of the terminal block	Cabling length
3.50 mm (0.14 in)	10 m (32.808 ft)

For more information about the wiring, refer to Best wiring practices ([see page 29](#)).

## Related Devices and Connectors

The table indicates the related devices and connectors

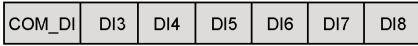
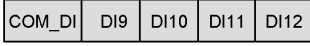
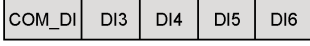
Related Device	Connector	Label	Description
TM172...28... TM172...42...	CN4 	COM-DI	Common for digital inputs 3...8
		DI3...DI8	Regular digital inputs 3...8
TM172...42...	CN12 	COM-DI	Common for digital inputs 9...12
		DI9...DI12	Regular digital inputs 9...12
TM172E28R	CN8 	COM-DI	Common for digital inputs 3...6
		DI3...DI6	Regular digital inputs 3...6

## Section 8.3

### Digital Output

#### Digital Output

This table presents the digital outputs of controllers and expansion modules:

Description	TM172P•G07R	TM172•••18R	TM172•••18S	TM172•••28R•	TM172•••28S•	TM172•••42R•	TM172•••42S•	TM172E12R	TM172E28R
High voltage relay SPST digital output <i>(see page 81)</i>	2	5	3	7	5	10	8	6	10
High voltage Solid-state relay digital output <i>(see page 83)</i>	-	-	2	-	2	-	2	-	-
High voltage relay SPDT digital output <i>(see page 84)</i>	1	1	1	1	1	2	2	-	-

These devices have analog outputs that can be configured as low voltage (SELV), open collector outputs. For more details, refer to the configuration of analog outputs *(see page 87)*.

**NOTE:** The commons C<sub>x</sub> are not internally connected together.

#### What Is in This Section?

This section contains the following topics:

Topic	Page
High voltage Relay SPST Digital Output	81
High Voltage Solid-State Relay Digital Output	83
High voltage Relay SPDT Digital Output	84



## High voltage Relay SPST Digital Output

### Characteristics

The table indicates the digital outputs characteristics:

Characteristic	Value
Maximum voltage	250 Vac
Maximum current	3 A resistive load, 2 FLA / 12 LRA
Minimum switching capacity	100 mA / 5 Vdc
Electrical durability conforming to UL60730	100 000 cycles, 3 A at 250 Vac

### Wiring Diagram Example

TM172•••28•• (CN7) SPST relay output:

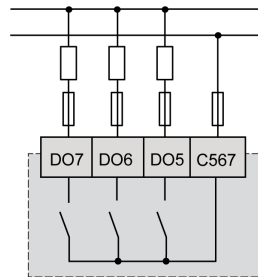

Pitch of the terminal block
5.00 mm (0.197 in)

For more information about the wiring, refer to Best wiring practices ([see page 29](#)).

### Related Devices and Connectors

The table indicates the related devices and connectors

Related Device	Connector		Label	Description
TM172•••07• TM172•••18•	CN9		C12	Common for output relays 1...2 Maximum current: 6 A
			DO1...DO2	Output relays 1...2
TM172•••18R	CN15		C4	Common for output relay 4 Maximum current: 3 A
			C5	Common for output relay 5 Maximum current: 3 A
			C6	Common for output relay 6 Maximum current: 3 A
			DO4...DO6	Output relays 4...6
TM172•••18S	CN15		C6	Common for output relay 6 Maximum current: 3 A
			DO6	Output relay 6 <b>NOTE:</b> DO4 and DO5 are SSR outputs ( <a href="#">see page 83</a> ).

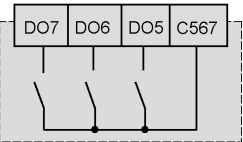
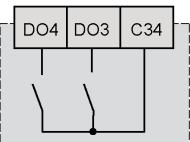
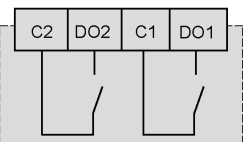
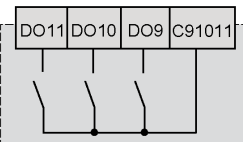
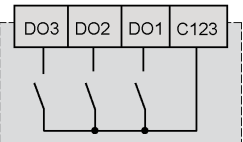
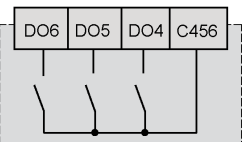
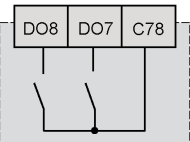
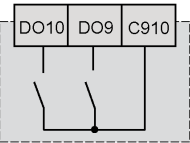
Related Device	Connector		Label	Description
TM172•••28•• TM172•••42••	CN7		C567	Common for output relays 5...7 Maximum current: 9 A
			DO5...DO7	Output relays 5...7
	CN8		C34	Common for output relays 3...4 Maximum current: 6 A
			DO3...DO4	Output relays 3...4
TM172•••28R• TM172•••42R•	CN9		C1	Common for output relay 1 Maximum current: 3 A
			C2	Common for output relay 2 Maximum current: 3 A
			DO1...DO2	Output relays 1...2
TM172•••42••	CN15		C91011	Common for output relays 9...11 Maximum current: 9 A
			DO9...DO11	Output relays 9...11
TM172E••R	CN5		C123	Common for output relays 1...3 Maximum current: 9 A
			DO1...DO3	Output relays 1...3
	CN4		C456	Common for output relays 4...6 Maximum current: 9 A
			DO4...DO6	Output relays 4...6
TM172E28R	CN11		C78	Common for output relays 7...8 Maximum current: 6 A
			DO7...DO8	Output relays 7...8
	CN10		C910	Common for output relays 9...10 Maximum current: 6 A
			DO9...DO10	Output relays 9...10

## High Voltage Solid-State Relay Digital Output

### Characteristics

The table indicates the SSR output characteristics:

Characteristic	Value	
	TM172...18S	TM172...28S• TM172...42S•
Nominal voltage	75...240 Vac	
Maximum current	0.2 A	0.5 A
Switching rate range	45...65 Hz	
Minimum switching capacity	20 mA	

### Wiring Diagram Example

TM172...28S• (CN9) SSR output:

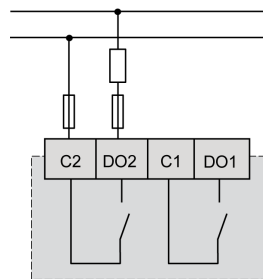

Pitch of the terminal block
5.00 mm (0.197 in)

For more information about the wiring, refer to Best wiring practices ([see page 29](#)).

### Related Devices and Connectors

The table indicates the related devices and connectors

Related Device	Connector	Label	Description
TM172...18S		C4	Common for SSR output 4 Maximum current: 0.2 A
		C5	Common for SSR output 5 Maximum current: 0.2 A
		DO4...DO5	SSR Outputs 4...5 <b>NOTE:</b> DO6 is not an SSR output. ( <a href="#">see page 81</a> )
TM172...28S• TM172...42S•		C1	Common for SSR output 1 Maximum current: 0.5 A
		C2	Common for SSR output 2 Maximum current: 0.5 A
		DO1...DO2	SSR Outputs 1...2

## High voltage Relay SPDT Digital Output

### Characteristics

The table indicates the digital outputs characteristics:

Characteristic	Value	
	TM172...07• TM172...18• TM172P...28•I TM172P...42•I TM172O...28R TM172O...42R	TM172P...28• TM172P...42•
Maximum voltage	250 Vac	240 Vac
Maximum current	3 A resistive load, NO contact: 2.2 FLA / 13.2 LRA	-20...55 °C (-4...131 °F): 3 A resistive load -20...60 °C (-4...140 °F): 1 A resistive load -20...65 °C (-4...149 °F): 1 A resistive load if DO8 is inactive
Minimum switching capacity	300 mA, resistive load	300 mA, resistive load
Electrical durability conforming to UL60730	100 000 cycles	100 000 cycles

### Wiring Diagram Example

TM172...28• / TM172...42• (CN6) SPDT relay output:

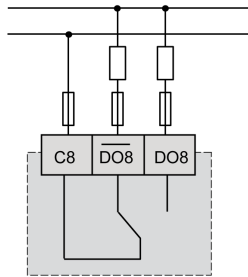

Pitch of the terminal block
5.00 mm (0.197 in)

For more information about the wiring, refer to Best wiring practices ([see page 29](#)).

### Related Devices and Connectors

The table indicates the related devices and connectors

Related Device	Connector		Label	Description
TM172...07• TM172...18•	CN6		C3	Common for output relay 3 Maximum current: 3 A
			DO3	Output relay3 - Normally open
			DO3-	Output relay 3 - Normally closed
TM172...28• TM172...42•	CN6		C8	Common for output relay 8 Maximum current: 3 A <sup>(1)(2)</sup>
			DO8	Output relay 8 - Normally open
			DO8-	Output relay 8 - Normally closed

(1) TM172P...28• / TM172P...42•: The maximum current is limited to 1 A if the ambient temperature exceeds 55 °C (131 °F).  
 (2) TM172P...28• / TM172P...42•: The ambient temperature must not exceed 60 °C (140 °F) if DO8 is active.

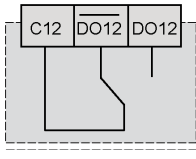
Related Device	Connector		Label	Description
TM172•••42••	CN14		C12	Common for output relay 12 Maximum current: 3 A <sup>(1)</sup>
			DO12	Output relay 12 - Normally open
			DO12-	Output relay 12 - Normally closed
<p><b>(1)</b> TM172P••28• / TM172P••42•: The maximum current is limited to 1 A if the ambient temperature exceeds 55 °C (131 °F).</p> <p><b>(2)</b> TM172P••28• / TM172P••42•: The ambient temperature must not exceed 60 °C (140 °F) if DO8 is active.</p>				

## Section 8.4

### Analog Inputs

#### Analog Inputs

This table presents the analog inputs of controllers and expansion modules:

Description	TM172P•G07R	TM172...18R	TM172...18S	TM172...28R•	TM172...28S•	TM172...42R•	TM172...42S•	TM172E12R	TM172E28R
Configurable analog inputs or digital input.	2	8	8	8	8	12	12	4	10

#### What Is in This Section?

This section contains the following topics:

Topic	Page
Analog Inputs	87
NTC Analog Input	91
Resistive Analog Input	92
Current Analog Input	94
Voltage Analog Input	95
Analog Input Used as Digital Input	96

## Analog Inputs

### Overview

Controllers analog inputs are identified as AI1...AIx.

The inputs are configurable in pairs, AI1- AI2 is the first pair, AI3-AI4 is the second pair, and so on, up to the last pair. Both AIs of a pair must be configured in order to belong to the same type group.

Using the parameter *Cfg\_Aix*, an analog input AIx can be configured to acquire a signal by a physical resource (probe, digital input, voltage/current signal) as specified in the following table:

Type group	Cfg_Aix	Description
NTC resistive input ( <i>see page 91</i> ) or Digital input ( <i>see page 96</i> )	0	NTC (NK103), 10 kΩ at 25 °C, BETA value 3977
	1	Digital input
	2	NTC (103AT-2), 10 kΩ at 25 °C, BETA value 3435
	7	hΩ (NTC) <sup>(1)</sup>
Current input ( <i>see page 94</i> )	3	4...20 mA
	11	0...20 mA
Voltage input 0...10 Vdc ( <i>see page 95</i> )	4	0...10 Vdc
Voltage input 0...5 Vdc ( <i>see page 95</i> )	5	0...5 Vdc Ratiometric
	10	0...5 Vdc
Resistive input ( <i>see page 92</i> )	6	Pt1000
	8	daΩ (Pt1000) <sup>(2)</sup>
	9	PTC (KTY81)
<p>(1) Resistance value read, expressed in 0.1 kΩ, for a resistance applied to the input using the controller in NTC configuration, for example creating a divider with pull-up resistance of 10 kΩ. The resistance range for the hΩ(NTC) configuration is up to 150 kΩ.</p> <p>(2) Resistance value read, expressed in 0.01 kΩ, for a resistance applied to the input using the controller in Pt1000 configuration, that is, creating a divider with pull-up resistance (1.5 kΩ for TM172P•G07R / TM172•••18•, 2 kΩ for other device references). The resistance range for the daΩ (Pt1000) configuration is up to 3 kΩ.</p>		

The analog inputs configured as digital inputs are not isolated.

## **NOTICE**

### INOPERABLE EQUIPMENT

Only use voltage free type inputs on analog inputs configured as digital inputs.

**Failure to follow these instructions can result in equipment damage.**

### Compatibility in Pairs

Parameters by pair

Pairs	Parameter Set	
Pair #1	Cfg_Ai1	Cfg_Ai2
Pair #2	Cfg_Ai3	Cfg_Ai4
Pair #3	Cfg_Ai5	Cfg_Ai6
Pair #4	Cfg_Ai7	Cfg_Ai8
Pair #5	Cfg_Ai9	Cfg_Ai10
Pair #6	Cfg_Ai11	Cfg_Ai12

**NOTE:** The all pairs are available for TM172•••42••. Depending on the analog inputs of the device, not all pairs are available, refer to the Related Devices and Connectors (*see page 89*).

Compatibility table for a pair of AIs:

Example for pair #1		Cfg_Ai1											
		0	1	2	3	4	5	6	7	8	9	10	11
		NTC (NK103)	Digital input	NTC (103AT-2)	4...20 mA	0...10 Vdc	0...5 Vdc Ratiometric	Pt1000	hΩ (NTC)	daΩ (Pt1000)	PTC (KTY81)	0...5 Vdc	0...20 mA
Cfg_Ai2	0	NTC (NK103)	✓	✓	✓	-	-	-	-	✓	-	-	-
	1	Digital input	✓	✓	✓	-	-	-	-	✓	-	-	-
	2	NTC (103AT-2)	✓	✓	✓	-	-	-	-	✓	-	-	-
	3	4...20 mA	-	-	-	✓	-	-	-	-	-	-	✓
	4	0...10 Vdc	-	-	-	-	✓	-	-	-	-	-	-
	5	0...5 Vdc Ratiometric	-	-	-	-	-	✓	-	-	-	✓	-
	6	Pt1000	-	-	-	-	-	-	✓	-	✓	✓	-
	7	hΩ (NTC)	✓	✓	✓	-	-	-	-	✓	-	-	-
	8	daΩ (Pt1000)	-	-	-	-	-	-	✓	-	✓	✓	-
	9	PTC (KTY81)	-	-	-	-	-	-	✓	-	✓	✓	-
	10	0...5 Vdc	-	-	-	-	-	✓	-	-	-	-	✓
	11	0...20 mA	-	-	-	✓	-	-	-	-	-	-	✓

Applying not allowed configuration produces the error number 8003<sub>h</sub> on the field value of both probes (unsigned decimal: 32771 / signed decimal: -32765).

**Voltage Analog Inputs or Current Analog Inputs Configuration**

According to the physical resources wired (voltage signal or current signal), inputs must be configured using the related parameters.

Analog inputs type can be configured as specified in the following table:

Parameter	Description	Range	Default value
FullScaleMin_AIx	Analog input AIx start of scale value	-9999...+9999	0
FullScaleMax_AIx	Analog input AIx full scale value	-9999...+9999	1000
Calibration_AIx	Analog input AIx differential	-1000...+1000	0

Note:

Type of probe configured	Minimum full scale AIx	Maximum full scale AIx
0/4...20 mA current probe	0/4 mA	20 mA
0...10 Vdc voltage probe	0 Vdc	10 Vdc
0...5 Vdc ratiometric probe	10 % (0.5 Vdc)	90 % (4.5 Vdc)
0...5 Vdc probe	0 Vdc	5 Vdc

For details on the values and characteristics of parameters, refer to the Parameters ([see page 133](#)).



## Related Devices and Connectors

The table indicates the related devices and connectors

Related Device	Connector	Label	Description
TM172***07• TM172***18•	CN5	AI1 AI2 GND 5 V out 24 V out	
		24 Vdc	+24 Vdc power out for analog inputs, max current 100 mA
		5 Vdc	+5 Vdc power out for ratiometric analog inputs, max current 40 mA
		GND	0 V signal ground
		AI1...AI2	Analog inputs 1... 2 or dry contact digital inputs
TM172***18•	CN13	AI3 AI4 AI5 AI6 AI7 AI8 GND	
		GND	0 V signal ground
		AI3...AI8	Analog inputs 3... 8 or dry contact digital inputs
TM172***28•• TM172***42••	CN5	AI1 AI2 AI3 AI4 AI5 AI6 AI7 AI8 GND 5 V out 24 V out	
		24 Vdc	+24 Vdc power out for analog inputs, max current 150 mA <sup>(1)</sup>
		5 Vdc	+5 Vdc power out for ratiometric analog inputs, max current 50 mA <sup>(1)</sup>
		GND	0 V signal ground
		AI1...AI8	Analog inputs 1... 8 or dry contact digital inputs
TM172***42••	CN13	AI9 AI10 AI11 AI12 GND 5 V out 24 V out	
		24 Vdc	+24 Vdc power out for analog inputs, max current 150 mA <sup>(1)</sup>
		5 Vdc	+5 Vdc power out for ratiometric analog inputs, max current 50 mA <sup>(1)</sup>
		GND	0 V signal ground
		AI9...AI12	Analog inputs 9...12 for dry contact digital inputs
TM172E••R	CN3	AI1 AI2 AI3 AI4 GND 5 V out 24 V out	
		24 Vdc	+24 Vdc power out for analog inputs, max current 125 mA <sup>(1)</sup>
		5 Vdc	+5 Vdc power out for ratiometric analog inputs, max current 50 mA <sup>(1)</sup>
		GND	0 V signal ground
		AI1...AI4	Analog inputs 1...4 or dry contact digital inputs
TM172E28R	CN9	AI5 AI6 AI7 AI8 AI9 AI10 GND 5 V out 24 V out	
		24 Vdc	+24 Vdc power out for analog inputs, max current 125mA <sup>(1)</sup>
		5 Vdc	+5 Vdc power out for ratiometric analog inputs, max current 50 mA <sup>(1)</sup>
		GND	0 V signal ground
		AI5...AI10	Analog inputs 5...10 or dry contact digital inputs
<b>(1)</b> The maximum current value is the sum between the maximum currents supplied by the corresponding terminals in the base board connector and in the upper board connector.			

**TM172DCLWT•• Display Embedded Analog Inputs Parameters**

The temperature and humidity sensors analog input are embedded in the display.

The parameters related to the analog inputs are listed in the following table:

Parameter	Description	Range
Temp_UM	Unit of temperature measurement	Value 0: °C Value 1: °F
Calibration_NTC	NTC differential	-18.0...+18.0 Unit: 0.1 °C or °F
Calibration_RH	RH percentage differential	-1000...+1000 Unit: 0.1 %RH

For details on the values and characteristics of parameters, refer to the Parameters ([see page 158](#)).

## NTC Analog Input

### Characteristics

Using the parameter `Cfg_Aix`, an analog input `AIx` can be configured to acquire a signal by a physical resource (probe, digital input, voltage/current signal) as specified in the following table:

Cfg_Aix	Description	Accuracy Range	Accuracy	Resolution	Input Impedance	
0	NTC (NK103) 10 kΩ at 25 °C BETA value 3977	-40...+137 °C (-40...+278.6 °F)				
		-40...+110 °C (-40...+230 °F)	+/-1 °C (+/-1.8 °F)	0.1 °C (0.18 °F)	10 kΩ	
		+110...+137 °C (+230...+278.6 °F)	+/-1.9 °C (+/-3.42 °F)			
2	NTC (103AT-2) 10 kΩ at 25 °C BETA value 3435	-50...+110 °C (-58...+230 °F)	+/-1 °C (+/-1.8 °F)	0.1 °C (0.18 °F)		10 kΩ
7	hΩ (NTC)	0...150 kΩ				
	TM172P••07• TM172•••18•	0...75 kΩ	+/-0.85 kΩ	0.1 kΩ	10 kΩ	
		75...150 kΩ	+/-2.4 kΩ			
	TM172•••28•• TM172•••42••	0...150 kΩ				+/-0.85 kΩ
		TM172E••R	0...70 kΩ			+/-1 kΩ
	70...120 kΩ		+/-2.5 kΩ			
120...150 kΩ	+/-6 kΩ					

### Wiring Diagram Example

TM172•••28•• / TM172•••42•• CN5 NTC input connection:

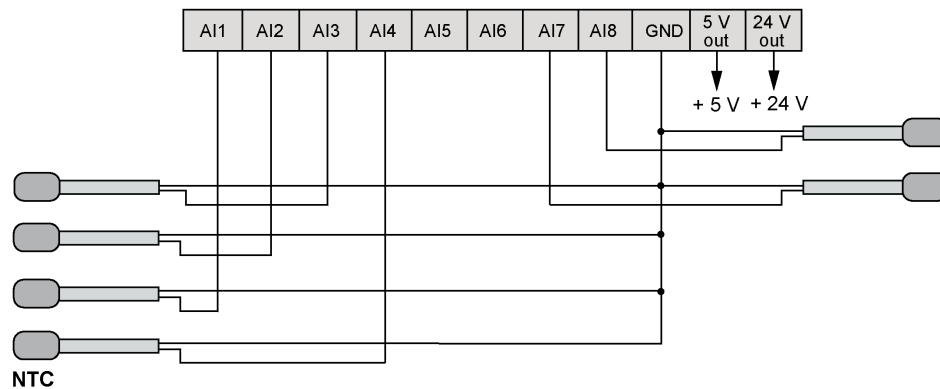

Pitch of the terminal block	Cabling length
3.50 mm (0.14 in)	10 m (32.808 ft)

For more information about the wiring, refer to wiring best practices ([see page 29](#)).

## Resistive Analog Input

### Characteristics

Using the parameter `Cfg_Aix`, an analog input `AIx` can be configured to acquire a signal by a physical resource (probe, digital input, voltage/current signal) as specified in the following table:

Cfg_Aix	Description	Accuracy Range	Accuracy	Resolution	Input Impedance	
6	Pt1000	-200...+850 °C (-328...+1562 °F)				
	TM172P**07• TM172***18• TM172***28** TM172***42**	-200...-100 °C (-328...-148 °F)	+/-10 °C (+/-18 °F)	0.1 °C (+/-0.18 °F)	1.5 kΩ	
		-100...-51 °C (-148...-59.8 °F)	+/-2.5 °C (+/-4.5 °F)			TM172P**07• TM172***18•
		-50...+100 °C (-58...+212 °F)	+/-1.5 °C (+/-2.7 °F)			2 kΩ
		+101...+400 °C (+213.8...+752 °F)	+/-2.4 °C (+/-4.32 °F)			TM172***28** TM172***42**
		+400...+850 °C (+753.8...+1562 °F)	+/-10 °C (+/-18 °F)			
	TM172E**R	-200...-100 °C (-328...-148 °F)	+/-5 °C (+/-9 °F)	0.1 °C (+/-0.18 °F)	2 kΩ	
		-100...-50 °C (-148...-58 °F)	+/-3 °C (+/-5.4 °F)			
		-50...+200 °C (-58...+392 °F)	+/-1.5 °C (+/-2.7 °F)			
		+200...+600 °C (+392...+1112 °F)	+/-15 °C (+/-27 °F)			
+600...+850 °C (+1112...+1562 °F)		+/-30 °C (+/-54 °F)				
8	daΩ (Pt1000)	0...3 kΩ	+/-25 Ω	10 Ω	1.5 kΩ	
					TM172P**07• TM172***18•	
					2 kΩ	
					TM172***28** TM172***42** TM172E**R	
9	PTC (KTY81)	-55...+150 °C (-67...+302 °F)				
	TM172P**07• TM172***18• TM172***28** TM172***42**	-55...+150 °C (-67...+302 °F)	+/-1.1 °C (+/-1.98 °F)	0.1 °C (0.18 °F)	1.5 kΩ	
					TM172P**07• TM172***18•	
					2 kΩ	
	TM172E**R	-55...+135 °C (-67...+275 °F)	+/-1.1 °C (+/-1.98 °F)	0.1 °C (0.18 °F)	2 kΩ	
+135...+150 °C (+275...+302 °F)		+/-3.1 °C (+/-5.58 °F)				

### Wiring Diagram Example

TM172...28... / TM172...42... CN5 Pt1000 (AI5 and AI6) inputs connection:

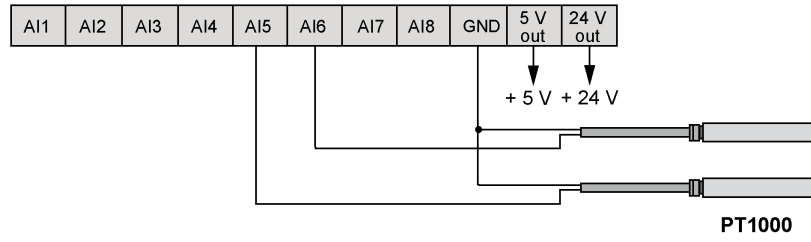

Pitch of the terminal block	Cabling length
3.50 mm (0.14 in)	10 m (32.808 ft)

For more information about the wiring, refer to wiring best practices ([see page 29](#)).

## Current Analog Input

### Characteristics

Using the parameter `Cfg_Aix`, an analog input  $AI_x$  can be configured to acquire a signal by a physical resource (probe, digital input, voltage/current signal) as specified in the following table:

Cfg_Aix	Description	Range	Accuracy Range	Resolution	Input Impedance
3	4...20 mA	-9999...9999 Default: 0...1000	4...20 mA +/-1 % full range + 1 digit	1 digit	<150 Ω
11	0...20 mA		0...4 mA +/-2 % full range + 1 digit		
			4...20 mA +/-1 % full range + 1 digit		

### Wiring Diagram Example

TM172...28... / TM172...42... (CN5) current input connection:

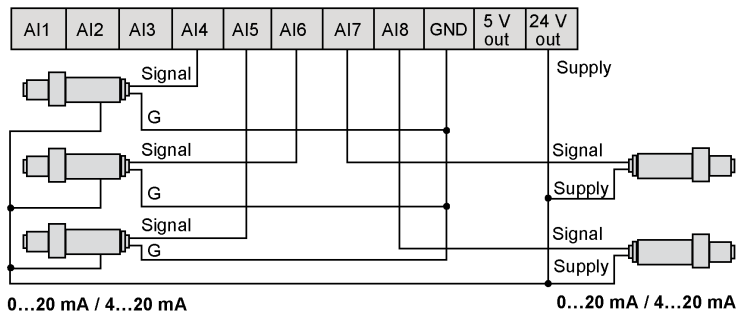

You can power the transducer from the M172 (5 Vdc or 24 Vdc) or with an external supply. For more information, refer to transducer technical data sheet.

Pitch of the terminal block	Cabling length
3.50 mm (0.14 in)	10 m (32.808 ft)

For more information about the wiring, refer to wiring best practices ([see page 29](#)).

## Voltage Analog Input

### Characteristics

Using the parameter `Cfg_Aix`, an analog input  $AI_x$  can be configured to acquire a signal by a physical resource (probe, digital input, voltage/current signal) as specified in the following table:

Cfg_Aix	Description	Range	Accuracy Range	Resolution	Input Impedance
4	0...10 Vdc	-9999...9999 Default: 0...1000	0...10 Vdc +/-1 % full range + 1 digit	1 digit	>10 kΩ
					TM172...07• TM172...18• TM172...28•• TM172...42••
					>20 kΩ
					TM172E••R
10	0...5 Vdc	-9999...9999 Default: 0...1000	0...5 Vdc +/-1 % full range + 1 digit	1 digit	>20 kΩ
					TM172...07• TM172...18• TM172...28•• TM172...42••
					>60 kΩ
					TM172E••R
5	0...5 Vdc Ratiometric	-9999...9999 Default: 0...1000	10 % 5 Vdc...90 % 5 Vdc +/-1 % full range + 1 digit	1 digit	>20 kΩ
					TM172...07• TM172...18• TM172...28•• TM172...42••
					>60 kΩ
					TM172E••R

### Wiring Diagram Example

TM172...28•• / TM172...42•• (CN5) voltage input connection:

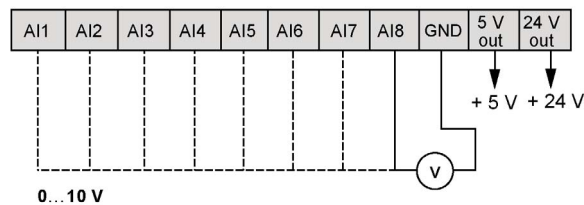

TM172...28•• / TM172...42•• (CN5) 0-5V ratiometric voltage input connection:

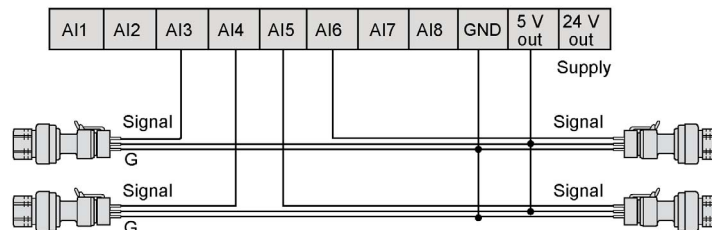

Pitch of the terminal block	Cabling length
3.50 mm (0.14 in)	10 m (32.808 ft)

For more information about the wiring, refer to wiring best practices ([see page 29](#)).

## Analog Input Used as Digital Input

### Characteristics

Using the parameter `Cfg_Aix`, an analog input AI<sub>x</sub> can be configured to acquire a signal by a physical resource (probe, digital input, voltage/current signal) as specified in the following table:

Cfg_Aix	Description	Range	Accuracy Range	Accuracy	Resolution	Input Impedance
1	Digital input <sup>(1)</sup>	-	-	-	-	10 kΩ

(1) The analog inputs configured as digital inputs are not isolated.

The use of an external power supply with the dry contact digital inputs can result in equipment damage.

<i>NOTICE</i>
<b>INOPERABLE EQUIPMENT</b>
Do not apply external power supply to the dry contact digital inputs of the device.
<b>Failure to follow these instructions can result in equipment damage.</b>

### Wiring Diagram Example

TM172...28... / TM172...42... (CN5) analog input used as digital input connection:

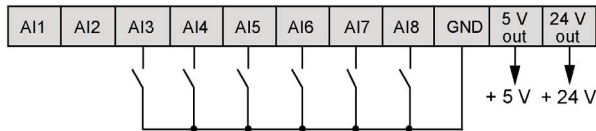

Pitch of the terminal block	Cabling length
3.50 mm (0.14 in)	10 m (32.808 ft)

For more information about the wiring, refer to wiring best practices ([see page 29](#)).



## Section 8.5

### Analog Outputs

#### Analog Outputs

This table presents the analog outputs of controllers and expansion modules:

Description	TM172P-G07R	TM172...18R	TM172...18S	TM172...28R	TM172...28S	TM172...42R	TM172...42S	TM172E12R	TM172E28R
Low voltage (SELV) analog outputs, or Open Collector PWM outputs	-	2	2	2	2	2	2	-	2
Low voltage (SELV) analog outputs	-	-	-	2	2	4	4	-	-

#### What Is in This Section?

This section contains the following topics:

Topic	Page
Analog Outputs	98
PWM Open Collector Outputs	99
Low Voltage (SELV) Analog Outputs	100
Analog Current Output	101
Current ON/OFF Current Output	102

## Analog Outputs

### Overview

Analog outputs are identified as AO1...AO<sub>x</sub>.

Analog outputs by device reference:

Device references	Non-configurable analog outputs	Configurable analog outputs
TM172...18•	-	AO1, AO2
TM172...28••	AO1, AO2	AO3, AO4
TM172...42••	AO1, AO2, AO5, and AO6	
TM172E28R	-	AO1, AO2

Devices are equipped with low voltage analog output (SELV) 0...10 Vdc (*see page 100*)

Using the parameter `Cfg_AOx`, configurable analog outputs AO<sub>x</sub> can be configured to provide a signal to a physical resource as specified in the following table:

Cfg_AO <sub>x</sub>	Description
0	Current modulation 4...20 mA ( <i>see page 101</i> )
1	Current ON/OFF ( <i>see page 102</i> )
2	Voltage modulation 0...10 Vdc ( <i>see page 100</i> )
3	PWM open collector ( <i>see page 99</i> )

### Related Devices and Connectors

The table indicates the related devices and connectors

Related Device	Connector	Label	Description
TM172...18•	CN11	GND	0 V signal ground
		AO1 AO2	Analog outputs 1...2
TM172...28•• TM172...42••	CN2	GND	0 V signal ground
		AO1 AO2 AO3 AO4	Analog outputs 1...4
TM172...42••	CN11	GND	0 V signal ground
		AO5 AO6	Analog outputs 5...6
TM172E28R	CN7	GND	0 V signal ground
		AO1 AO2	Analog outputs 1...2

## PWM Open Collector Outputs

### Characteristics

PWM open collector (configurable polarity) configurable analog output characteristics:

Analog output	<ul style="list-style-type: none"> <li>Frequency</li> <li>Duty cycle</li> </ul>			Maximum Sink Current	Maximum Supplies Voltage
	Range	Accuracy	Resolution		
AO1, AO2	<ul style="list-style-type: none"> <li>0...2000 Hz</li> <li>0.0...100.0 %</li> </ul>	<ul style="list-style-type: none"> <li>1 Hz</li> <li>0.1 %</li> </ul>	<ul style="list-style-type: none"> <li>1 Hz</li> <li>0.1 %</li> </ul>	50 mA	24 Vdc
TM172...18• TM172E28R					
AO3, AO4				30 mA	
TM172P...28•I TM172P...42•I TM172O...28R TM172O...42R					
AO3, AO4				30 mA	
TM172P...28• TM172P...42•					

Analog outputs in PWM mode can be configured as specified in the following table:

Parameter	Description	Range
PWM_frequency_AO1_AO2	PWM Frequency	0...2000 Hz
PWM_frequency_AO3_AO4		
PWM_polarity_AO1_AO2	PWM Polarity	0...1
PWM_polarity_AO3_AO4		

**NOTE:** The polarity and the frequency are common for the 2 configurable analog outputs of each device. For details on the values and characteristics of the parameters, refer to Parameters ([see page 133](#)).

### Wiring Diagram Example

TM172...28• / TM172...42• (CN2) open collector PWM analog input (AO3) connection:

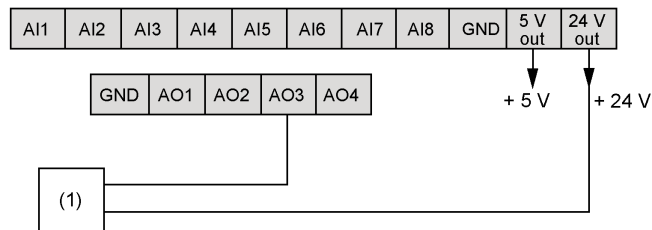

(1) Third-party actuator (for example: fan module) or external relay

Pitch of the terminal block	Cabling length
3.50 mm (0.14 in)	10 m (32.808 ft)

For more information about the wiring, refer to wiring best practices ([see page 29](#)).

## Low Voltage (SELV) Analog Outputs

### Characteristics

Voltage modulation 0...10 Vdc non-configurable analog output characteristics:

Analog output	Range	Accuracy	Resolution	Load Impedance
AO1, AO2	0...1000	+/-2 % full scale	1 digit	> 700 Ω
TM172...28**				
AO1, AO2, AO5, and AO6	0...1000	+/-2 % full scale	1 digit	> 700 Ω
TM172...42**				

Voltage modulation 0...10 Vdc configurable analog output characteristics:

Analog output	Range	Accuracy	Resolution	Load Impedance
AO1, AO2	0...1000	+/-2 % full scale	1 digit	≥700 Ω
TM172...18* TM172E28R				
AO3, AO4	0...1000	+/-2 % full scale	1 digit	≥700 Ω
TM172...28** TM172...42**				

### Wiring Diagram Example

TM172...28\*\* / TM172...42\*\* (CN2) Low voltage (SELV) analog outputs (AO2, AO3, and AO4) connection:

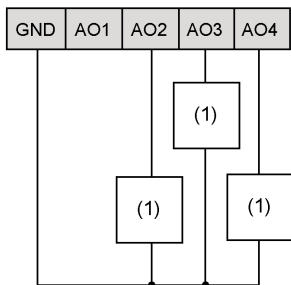

(1) Third-party actuator (for example: fan module)

Pitch of the terminal block	Cabling length
3.50 mm (0.14 in)	10 m (32.808 ft)

For more information about the wiring, refer to wiring best practices ([see page 29](#)).

## Analog Current Output

### Characteristics

Current modulation 4...20 mA (*see page 101*) configurable analog output characteristics:

Analog output	Range	Accuracy	Resolution	Load Impedance
AO1, AO2	0...1000	+/-2 % full scale	1 digit	≤450 Ω
TM172...18• TM172E28R				
AO3, AO4				
TM172...28•• TM172...42••				

### Wiring Diagram Example

TM172...28•• / TM172...42•• (CN2) low voltage (SELV) analog outputs (AO3, and AO4) connection:

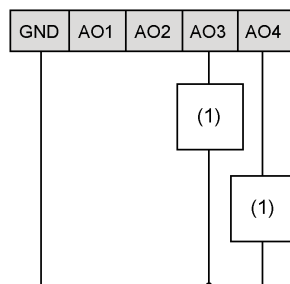

(1) Third-party actuator (for example: fan module)

Pitch of the terminal block	Cabling length
3.50 mm (0.14 in)	10 m (32.808 ft)

For more information about the wiring, refer to wiring best practices (*see page 29*).

## Current ON/OFF Current Output

### Characteristics

Current ON-OFF configurable analog output characteristics:

Analog output	Current ON	Current OFF
AO1, AO2		
TM172...18•	23 mA	0 mA
TM172E28R	20 mA	
AO3, AO4		
TM172...28•• TM172...42••	23 mA	0 mA

### Wiring Diagram Example

TM172...28•• / TM172...42•• (CN2) current ON/OFF analog output (AO3, and AO4) connection:

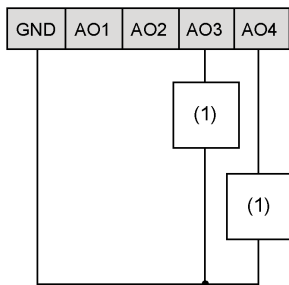

(1) Third-party actuator (for example: fan module)

Pitch of the terminal block	Cabling length
3.50 mm (0.14 in)	10 m (32.808 ft)

For more information about the wiring, refer to wiring best practices ([see page 29](#)).

---

## Section 8.6

### Communication

---

#### What Is in This Section?

This section contains the following topics:

Topic	Page
CAN Expansion Bus Port	104
RS-485 Serial Ports	107
USB Serial Ports	109
Ethernet Port	110

## CAN Expansion Bus Port

### Overview

The TM172P..... / TM172O..... controllers and TM172E..R expansion modules can be connected through the CAN expansion bus.

### Connector

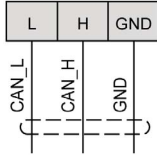

Pitch of the terminal block
3.50 mm (0.14 in)

### Wiring

Use a twisted pair shielded cable with two conductors with section 0.5 mm<sup>2</sup> (AWG 20), plus a sheath (characteristic impedance 120 Ω) with PVC sleeve, nominal capacity between conductors 36 pF/m, nominal capacity between conductor and shield 68 pF/m.

For laying wires, comply with the indications given in standard EN 50174 on information technology wiring. Extra care must be taken in separating data transmission circuits from power lines.

The network must have a bus daisy chain topology and must have 120 Ω 1/4 W termination resistances between the CAN\_H and CAN\_L terminals on each of the two ends of the bus or enable those embedded on the expansion modules.

The maximum cable length depends on the communication speed set in baud:

Baud rate	Maximum network length using:	
	Embedded CAN	TM171ACAN module
50 kBd	1000 m (3280.83 ft)	1000 m (3280.83 ft)
125 kBd	500 m (1640.41 ft)	500 m (1640.41 ft)
250 kBd	200 m (656.17 ft)	250 m (820.21 ft)
500 kBd	30 m (98.42 ft)	60 m (196.85 ft)

## ***NOTICE***

### INOPERABLE EQUIPMENT

- Do not connect equipment that communicate using RS-485 serial to CAN Expansion Bus terminals.
- Do not connect equipment that communicate using CAN Expansion Bus to RS-485 terminals.

**Failure to follow these instructions can result in equipment damage.**

### TM172E..R Port Configuration Using DIP Switch

The 6-position DIP switches on expansion modules is used to:

- Assert the 120 Ω termination (1)
- Set the CAN baud rate (2)
- Set the CAN address (3)

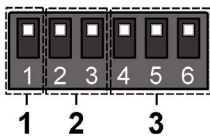

**NOTE:** The addressing comprises the sum of parameter `Addr_CAN_OB` (Default value: 1) plus the composite value of the 6-position DIP switches DIP4...DIP6 (8 addresses).



DIP number	1	2	3	4	5	6
	120 Ω	Baud		Address		
Disabled Default value		-		-		
Enabled						
500 kBd Default value	-			-		
250 kBd	-					
125 kBd	-					
50 kBd	-					
Address Addr_CAN_OB Default value	-	-				
Address Addr_CAN_OB + 1	-	-				
Address Addr_CAN_OB + 2	-	-				
Address Addr_CAN_OB + 3	-	-				
Address Addr_CAN_OB + 4	-	-				
Address Addr_CAN_OB + 5	-	-				
Address Addr_CAN_OB + 6	-	-				
Address Addr_CAN_OB + 7	-	-				

### CAN Expansion Bus (Field) Network Connection Example

A CAN Expansion Bus (Field) network connection can be constituted by:

- Maximum 1 TM172P..... / TM172O..... functioning as master
- Maximum 12 TM172E••R functioning as slaves. This number can be reduced, depending on the number of inputs and outputs that the master can control.

Non isolated power supply connection master example using a TM172PDG42R:

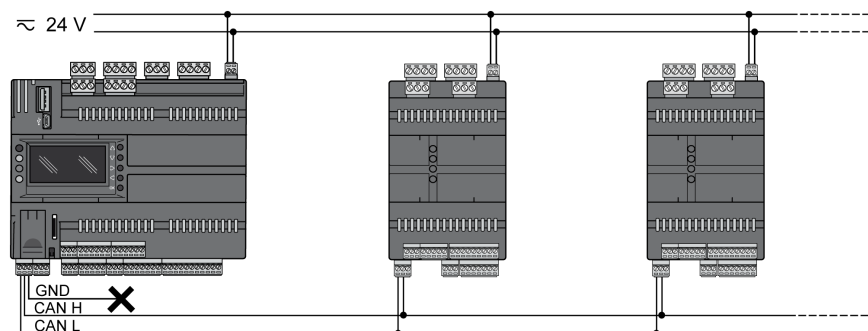

Isolated power supply connection example using a TM172PDG42RI:

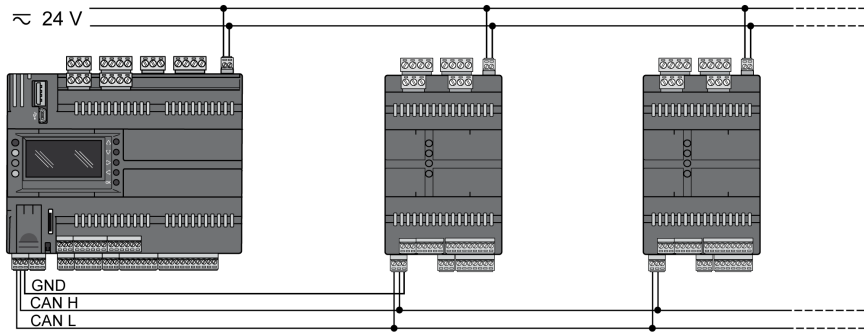

**CAN Expansion Bus Connection (Network) Example**

A CAN Expansion Bus (network) connection can be constituted by:

- Maximum 10 TM172P••••• / TM172O••••• connected in CAN binding. For more details on binding functionalities, refer to EcoStruxure Machine Expert - HVAC software - Operating Guide (see page 9).

Non isolated power supply connection example using TM172PDG42R:

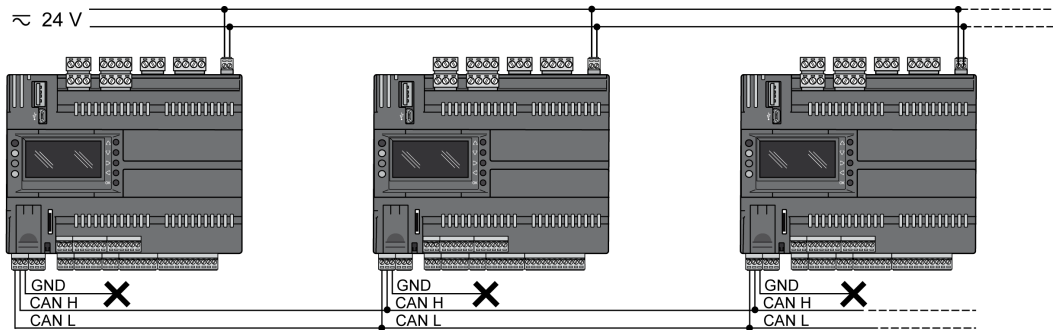

Isolated power supply connection example using TM172PDG42RI:

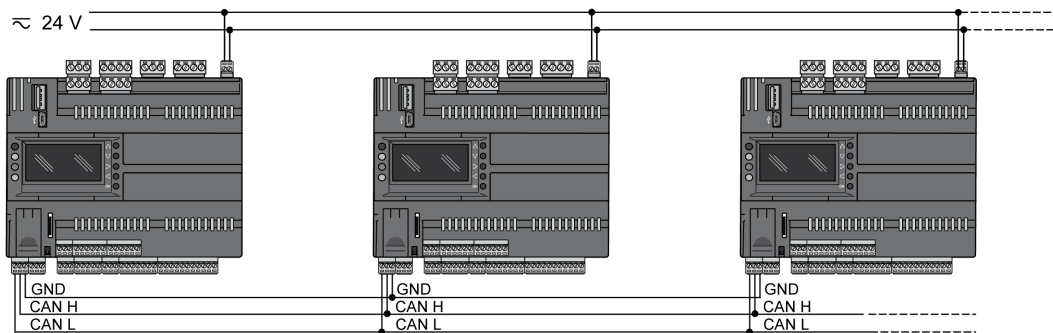

**Power Supply Restriction**

If you connect the GND connection of the network across multiple devices with power supply inputs that are non-isolated (TM172P••28•, TM172P••42•, or TM172E••R), use separate, isolated power supplies. Alternatively, if you are interconnecting the equipment to a single power supply, do not connect the GND signal. Pay special attention when connecting serial lines. Miswiring may lead to inoperable equipment.

For more details, refer to Power Supply description (see page 74).

## RS-485 Serial Ports

### Overview

Each TM172P..... / TM172O..... controller is equipped with 2 RS-485 serial ports.

These ports permit user to communicate between the controller and a device via:

- A Modbus RTU connection when using **RS485-1**(slave) or **RS485-2** (master or slave) communication port
- A BACnet MS/TP (B-AAC profile certified BTL) connection

### Connector of TM172P..... / TM172O..... Controllers

The TM172...07• / TM172...18• / TM172O...28R / TM172O...42R / TM172P...28•I / TM172P...42•I controllers are equipped with 2 RS-485 terminals:

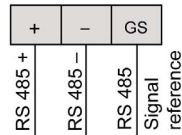

**NOTE:** GS of the **RS485-1** and **RS485-2** terminals are internally connected and are not connected to the GND of the device.

The TM172P...28• / TM172P...42• controllers are equipped with 2 RS-485 terminals:

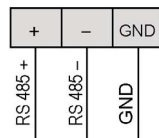

**NOTE:** GND of the **RS485-1** and **RS485-2** terminals are internally connected to the GND of the device.

### Cables

Use a shielded and "twisted pair" cable with two 0.5 mm<sup>2</sup> section conductors (AWG 20), plus braid (characteristic impedance 120 Ω) with PVC sleeve, nominal capacity between conductors 36 pF/m, nominal capacity between conductor and shielding 68 pF/m.

Alternatively use a shielded and "twisted pair" cable with two 0.5 mm<sup>2</sup> section conductors (AWG 20), plus braid with PVC sleeve, nominal capacity between conductors 89 pF/m, nominal capacity between conductor and shielding 161 pF/m. See EN 50174 standard on IT cabling for indications on how cables must be routed.

Always follow regulations applicable to the routing and connection of cables. Separate data transmission circuits from power lines.

RS-485 network up to 1200 m in length with a maximum of 32 devices can be connected directly to the controller. This length can be extended and the number of devices for each channel increased using appropriate repeater modules.

Single terminal strip with 3 conductors: use the 3 conductors ("+", "-" for the signal and "GND" for the braid).

Attach the 120 Ω 1/4 W resistors between the "+" and "-" terminals of the interface and the last controller in each branch of the network.

Maximum settable speed 115200 baud.

RS-485 physical layer can be used for Modbus SL, as well as for BACnet MS/TP communication. Concurrent communication of different protocols on the same serial port is not allowed.

## **NOTICE**

### **INOPERABLE EQUIPMENT**

Do not communicate through Modbus SL and BACnet MS/TP concurrently on the same serial port.

**Failure to follow these instructions can result in equipment damage.**

## NOTICE

**INOPERABLE EQUIPMENT**

- Do not connect equipment that communicate using RS-485 serial to CAN Expansion Bus terminals.
- Do not connect equipment that communicate using CAN Expansion Bus to RS-485 terminals.

**Failure to follow these instructions can result in equipment damage.**

**Power Supply Restriction**

If you connect the GND connection of the RS-485 network across multiple devices with power supply inputs that are non-isolated (TM172P••28•, or TM172P••42•), use separate, isolated power supplies. Alternatively, if you are interconnecting the equipment to a single power supply, do not connect the RS-485 GND signal. Pay special attention when connecting serial lines. Miswiring may lead to inoperable equipment.

For more details, refer to Power Supply description (see page 74).

**Wiring Examples**

The following diagram shows an RS-485 (field) architecture wiring example with non isolated controllers:

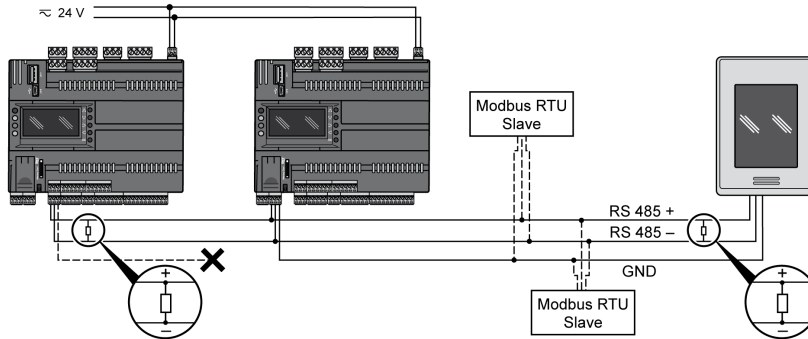

The following diagram shows an RS-485 (field) architecture wiring example with isolated controllers:

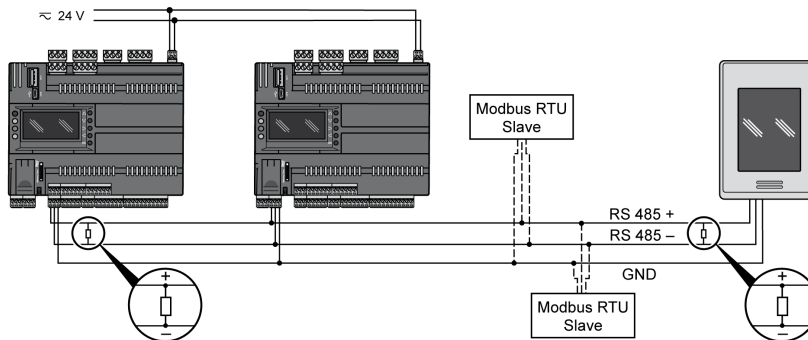

Characteristic	Definition
Type of trunk cable	Shielded cable with one twisted pair and at least a third conductor
Maximum length of bus	1000 m (3280.83 ft) at 19200 bps with a shielded and twisted cable (for example: TSXCSA•••)
Maximum number of devices (without repeater)	32 devices that are 31 slaves
Line terminators	120 Ω 1/4 W resistors

Pitch of the terminal block	Cabling length
3.50 mm (0.14 in)	1000 m (3280.83 ft)

## USB Serial Ports

### Overview

An USB type Mini-B (DEVICE) connector placed on the top-left side of the front view of the controller is used to connect the controller to a PC via Mini-B/A USB cable for debugging, commissioning, downloading, uploading with TM171SW (EcoStruxure Machine Expert - HVAC software).

For TM172P•••••, an additional USB type A (HOST) connector is used to connect a USB memory key when downloading the application.

For further information, refer to the commissioning part (*see page 163*).

### Connector of TM172••••• Controllers

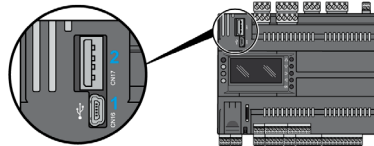

- 1 USB type Mini-B
- 2 USB type A (TM172P••••• only)

Cabling length
30 cm (11.8 in)

### Connection

The cables required for TM172P••••• / TM172O••••• controllers USB Mini-B are TCSXCNAMUM3P or BMXXCAUSBH018.

The TM172P••••• / TM172O••••• controllers can also be supplied through the Mini-B USB cable with limited functionalities related to debugging, commissioning, downloading and uploading with TM171SW (EcoStruxure Machine Expert - HVAC software). For more information, see the EcoStruxure Machine Expert - HVAC software, Programming Guide.

**NOTE:** Do not apply voltage via 24 Vac/dc while the equipment is already connected to a PC via Mini-B USB cable.

Before applying power via 24 Vac/dc power supply connection:

Step	Action
1	Disconnect the Mini-B USB cable.
2	Supply the M172 controller via its 24 Vac/dc supply.
3	Reconnect the Mini-B USB cable.

### Compatibility

TM172P••••• / TM172O••••• controller is seen as a virtual COM. Serial communication is performed with a CDC profile (USB standard).

Following operating systems are compatible:

- Windows 7 Home Premium 32 bit & 64 bit
- Windows 7 Professional 32 bit & 64 bit
- Windows 7 Ultimate 32 bit & 64 bit
- Windows 8 / 8.1 64 bit
- Windows 10 64 bit

The driver is supplied with the TM171SW (EcoStruxure Machine Expert - HVAC software) software.

## Ethernet Port

### Overview

Each TM172P••••• controller is equipped by an RJ45 Ethernet port.

The RJ45 Ethernet port is available as an option for TM172O••••• controller, by adding a Ethernet, Modbus TCP, and BACnet/IP or a Ethernet, Modbus TCP, BACnet/IP, Modbus SL, and BACnet MS/TP communication module (*see page 20*)

### Description

The Ethernet port permits user to connect the device to:

- Different controllers and/or applications exchanging variables and/or parameters (network).
- A supervision system using Modbus TCP/IP protocol.
- An IEC 61131-3 TM171SW (EcoStruxure Machine Expert - HVAC software) development system.
- A BACnet/IP network, with B-AAC profile.

Concurrent communication of different protocols using the same Ethernet port is allowed (use of a web browser in addition to another Ethernet Fieldbus connection for example).

### Web Functionalities

The M172P also features Web functionalities, offering makers of machinery and systems integrators remote access. Having a web-based connection in machines reduces support and maintenance by minimizing call-out charges. End users also benefit, as they can monitor their own systems both locally and from distance, using the graphics interface of any browser.

Main Web functionalities:

- Web-based access.
- Remote reading and support.
- Local and remote system control, including alarms management.
- Preventive and predictive maintenance.
- Email alarm alerts.

Care must be taken and provisions made for use of this product as a control device to avoid inadvertent consequences of commanded machine operation, controller state changes, or alteration of data memory or machine operating parameters.

## WARNING

### UNINTENDED EQUIPMENT OPERATION

- Configure and install the mechanism that enables the remote HMI local to the machine, so that local control over the machine can be maintained regardless of the remote commands sent to the application.
- You must have a complete understanding of the application and the machine before attempting to control the application remotely.
- Take the precautions necessary to assure that you are operating remotely on the intended machine by having clear, identifying documentation within the application and its remote connection.

**Failure to follow these instructions can result in death, serious injury, or equipment damage.**

### Bridge

TM171SW (EcoStruxure Machine Expert - HVAC software) allows monitoring of Modbus/RTU slaves, where M172P controller is the master Modbus/RTU.

In a TM171SW (EcoStruxure Machine Expert - HVAC software) project, M172P controller is used as a Modbus TCP to Modbus/RTU protocol conversion element for Modbus 03<sub>h</sub> and 10<sub>h</sub> commands.

From TM171SW (EcoStruxure Machine Expert - HVAC software), set the connection with the device as Modbus TCP, inserting the M172P controller IP address and the Modbus/RTU address of the device slave.

## Connector

### RJ45 Ethernet pin assignment

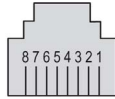

Pin number	Signal
1	TD+
2	TD-
3	RD+
4	-
5	-
6	RD-
7	-
8	-

**NOTE:** The controller supports the MDI/MDIX auto-crossover cable function. It is not necessary to use special Ethernet crossover cables to connect devices directly to this port (connections without an Ethernet hub or switch).

Cabling length
100 m (328 ft)

## Status LED

### RJ45 Ethernet status LED

Ethernet control

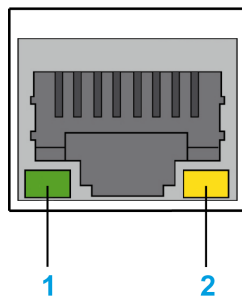

Label	Signal	LED		
		Color	Status	Description
1	Ethernet link	Green/Yellow	Off	No link
			Yellow On	Link at 10 Mb
			Green On	Link at 100 Mb
2	Ethernet activity	Green	Off	No activity
			Flashing	Activity

Architecture Wiring Examples

The following diagram shows an Ethernet architecture wiring example:

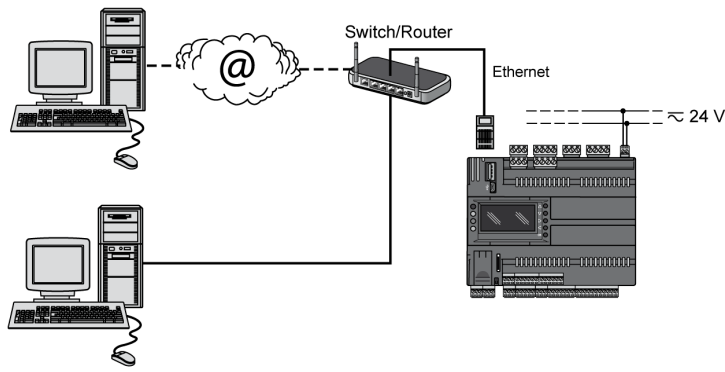

The following diagram shows a BACnet/IP architecture wiring example:

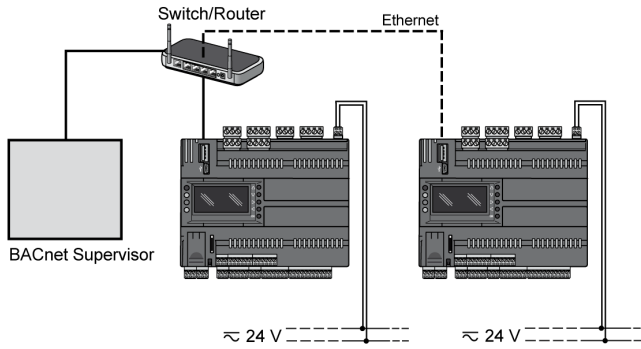



## Section 8.7

### Memory

#### Memory

##### Overview

The Modicon M172 Logic Controller has two different ways for data storing:

- Internal memory
- External memory (through a slot to insert external memory card, TM172P••••• only)

##### Internal Memory

The Modicon M172 Logic Controller has the following memory capacities:

Capacity	Type	Description
512 Kb	Flash	BIOS
96 Kb	RAM	BIOS and retain variables
8 Mb	NOR Flash	File System and BIOS
TM172P••07• / TM172P••18•: 16 Mb TM172P••28•• / TM172P••28••: 32 Mb	SDRAM	Application, HMI, and BIOS

**NOTE:** A RAM datablock (32 bit DWORD), referred to as retain memory can be addressed through EcoStruxure Machine Expert - HVAC software (TM171SW) at address %MD102.0, and allows data to be permanently stored, as it is with the Flash memory, as long as the RTC battery is active (*see page 115*). There is no limitation in the amount of read and write operations on this block.

##### External Memory

The Modicon M172 Logic Controller (TM172P•••••) has a Memory Card slot for micro SD cards to, in certain cases, extend internal memory for the File System (*see page 148*).

- Ultra High-Speed Class 1 (UHS-I) compatibility has been tested and validated with a 16 GB memory card.
- Ultra High-Speed Class 2 (UHS-II) memory cards are not supported.

Micro SD card slot characteristics:

Topic	Characteristics	Description
Supported type	Standard Capacity	Micro SD
	High Capacity	Micro SDHC
Global memory	Maximum capacity	32 GB
Speed	Supported classes	4, 6, and 10 Ultra high-speed class 1
Memory organization	Maximum size for files	4 GB
	Maximum number of files	512

When handling the micro SD card, follow the instructions below to help prevent internal data on the micro SD card from being corrupted or lost or a micro SD card malfunction from occurring:

<b><i>NOTICE</i></b>
<b>INOPERABLE EQUIPMENT</b> <ul style="list-style-type: none"><li>● Do not store the micro SD card where there is static electricity or probable electromagnetic fields.</li><li>● Do not store the micro SD card in direct sunlight, near a heater, or other locations where high temperatures can occur.</li><li>● Do not bend the micro SD card.</li><li>● Do not drop or strike the micro SD card against another object.</li><li>● Keep the micro SD card dry.</li><li>● Do not touch the micro SD card connectors.</li><li>● Do not disassemble or modify the micro SD card.</li><li>● Use only micro SD card formatted using FAT32.</li></ul> <b>Failure to follow these instructions can result in equipment damage.</b>

The TM172P\*\*\*\*\* controller does not recognize NTFS formatted micro SD cards. Format the micro SD card on your computer using FAT32.

When using the TM172P\*\*\*\*\* controller and a micro SD card, observe the following to avoid losing valuable data:

- Accidental data loss can occur at any time. Once data is lost, it cannot be recovered.
- If you forcibly extract the micro SD card, data on the micro SD card may become corrupted.
- Removing a micro SD card that is being accessed could damage the micro SD card, or corrupt its data.
- If the micro SD card is not positioned correctly when inserted into the controller, the data on the card and the controller could become damaged.

<b><i>NOTICE</i></b>
<b>LOSS OF APPLICATION DATA</b> <ul style="list-style-type: none"><li>● Backup micro SD card data regularly.</li><li>● Do not remove power or reset the controller, and do not insert or remove the micro SD card while it is being accessed.</li><li>● Become familiar with the proper orientation of the micro SD card when inserting it into the controller.</li></ul> <b>Failure to follow these instructions can result in equipment damage.</b>

## Section 8.8

### RTC (Real-Time Clock)

#### RTC (Real-Time Clock)

##### RTC Description

The table indicates the functions of the RTC:

Function	Description
RTC data retention time in the event of a power outage	10 years
Drift value	$\leq 30$ s/month at 25 °C

##### Battery

The Modicon M172 Logic Controller has a removable flap placed in the lower-left side of the front view. Behind the service door, there is a battery compartment and a 5-pole male connector (reserved). However, to replace the internal battery, contact your local Schneider Electric representative.

#### **WARNING**

##### **NON USER SERVICABLE COMPONENT**

Do not attempt to replace the battery.

**Failure to follow these instructions can result in death, serious injury, or equipment damage.**



# Chapter 9

## User Interface

### TM172PD..... / TM172OD..... User Interface

#### Overview

The user interface of the TM172PD..... / TM172OD..... controllers has 5 keys and 4 LEDs. The TM172PB..... / TM172OB..... logic controllers have no display. A TM172DCL..... remote display can be used.

#### Keys

The following indications refer to the TM172PD..... / TM172OD..... user interface.

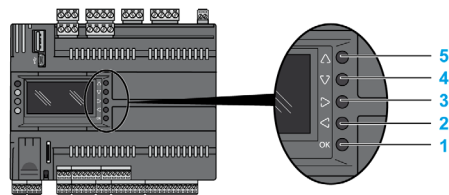

The keys can be programmed from the controller application. The following table describes the keys default setting in Edit Mode (keys are programmable from the controller application).

Description of keys actions:

Number	Key	Press once (press and release)	Press and hold
1	OK	<ul style="list-style-type: none"> <li>● Enter/exit Edit mode</li> <li>● Confirm operation in Edit Mode</li> </ul>	-
2	LEFT	<ul style="list-style-type: none"> <li>● Move cursor to left in Edit Mode</li> </ul>	<ul style="list-style-type: none"> <li>● Exit Edit Mode without saving</li> </ul>
3	RIGHT	<ul style="list-style-type: none"> <li>● Move cursor to right in Edit Mode</li> </ul>	-
4	DOWN	<ul style="list-style-type: none"> <li>● Decrease a value in Edit Mode</li> </ul>	-
5	UP	<ul style="list-style-type: none"> <li>● Increase a value in Edit Mode</li> </ul>	-

#### LEDs and Display

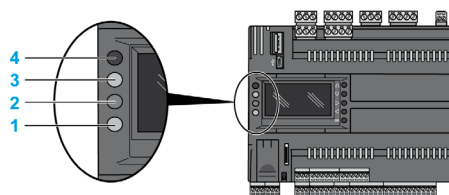

Number	LED	Color	Function
1	C	Green	Programmable from the controller application
2	B	Yellow	
3	A	Red	
4	P	Green	ON when the controller is powered

**NOTE:** By default, A, B, C LEDs are used for USB management.



---

# Part IV

## Remote Display

---

### What Is in This Part?

This part contains the following chapters:

Chapter	Chapter Name	Page
10	Environmental Characteristics	121
11	TM172DCL•••• Remote Display Description	123
12	Electrical Characteristics and Wiring Diagrams	127





# Chapter 10

## Environmental Characteristics

### Environmental Characteristics

#### Environmental Characteristics

Characteristics	Specification	TM172DCLWT**	TM172DCLF•
The product complies with the following harmonized regulations	EN60950-1:2006+A2:2013 EN55024:2010 EN55022:2010/AC2011	✓	-
	EN60730-1 EN60730-2-9	-	✓
Temperature for ball pressure test	125 °C (257 °F)	-	✓
Product certifications	CAN/CSA C22.2 No. 24-1993-06 UL 873:2007-11	✓	-
Environmental front panel rating	Type 1 enclosure	-	✓
Degree of protection by enclosure	IP20	✓	✓
	IP65 on front panel	-	✓
Construction of control	Electronic automatic Incorporated Control	-	✓
Purpose of control	Operating control (not safety)	✓	✓
Mounting	Vertical surface	✓	✓
	Flush	-	✓
	Top Hat (DIN rail)	-	✓
Type of action	1	-	✓
Pollution degree	2 (normal)	-	✓
Insulation material group	IIIa	-	✓
Over-voltage category	II	-	✓
Rated impulse voltage	330 V	-	✓
Period of electric stress on the insulating parts	N/A	-	-
Ambient operating temperature	0...50 °C (32...122 °F)	✓	-
	-20...60 °C (-4...140 °F)	-	✓
Ambient operating humidity (non-condensing)	0...75 %	✓	✓
Ambient storage temperature	-30...50 °C (-22...122 °F)	✓	-
	-30...60 °C (-22...140 °F)	-	✓
Ambient storage humidity (non-condensing)	0...75 %	✓	✓
Power supply	24 Vac +/-15 % 50/60 Hz	✓	✓
	24 Vdc +/-10 %		
Power consumption	3.2 VA 1.3 W max	✓	✓
Insulation class	III	-	✓
Fire-resistance category	D	-	✓
Software class and structure	A	-	✓
Type of disconnection or suspension for each circuit	N/A	-	-



---

# Chapter 11

## TM172DCL\*\*\*\* Remote Display Description

---

### What Is in This Chapter?

This chapter contains the following topics:

Topic	Page
TM172DCLWT**	124
TM172DCLF•	125

## TM172DCLWT

### Overview

Reference	Description
TM172DCLWT	M172 Color Touchscreen remote display vertical mounting with built-in temperature sensor
TM172DCLWTH	M172 Color Touchscreen remote display vertical mounting with built-in temperature and humidity sensors
TM172DCLWTHP	M172 Color Touchscreen remote display vertical mounting with built-in temperature, humidity, and presence (PIR) sensors

### Physical Description

The following illustrations present a TM172DCLWT remote display:

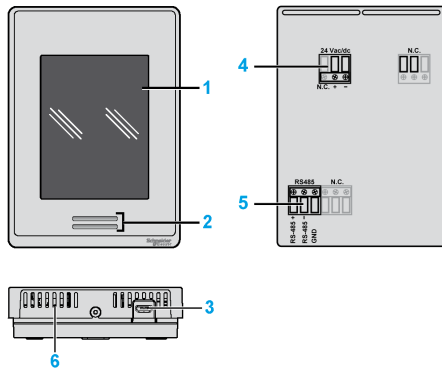

Number	Description
1	Touchscreen
2	Holes for PIR detection
3	USB Micro-B port
4	Power supply connector
5	RS-485 Modbus SL connector
6	Holes for temperature measurement

### Dimension

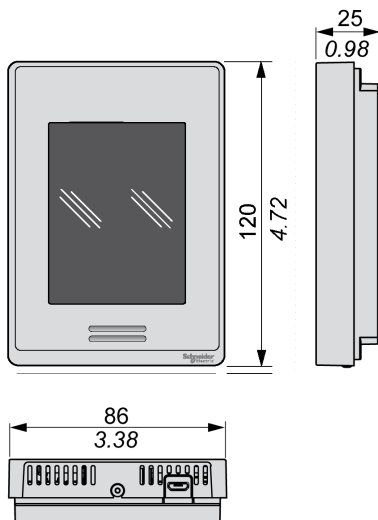

## TM172DCLF•

### Overview

Reference	Description
TM172DCLFW	M172 Color Touchscreen remote display flush mounting gray
TM172DCLFG	M172 Color Touchscreen remote display flush mounting white

### Physical Description

The following illustrations present a TM172DCLF• remote display:

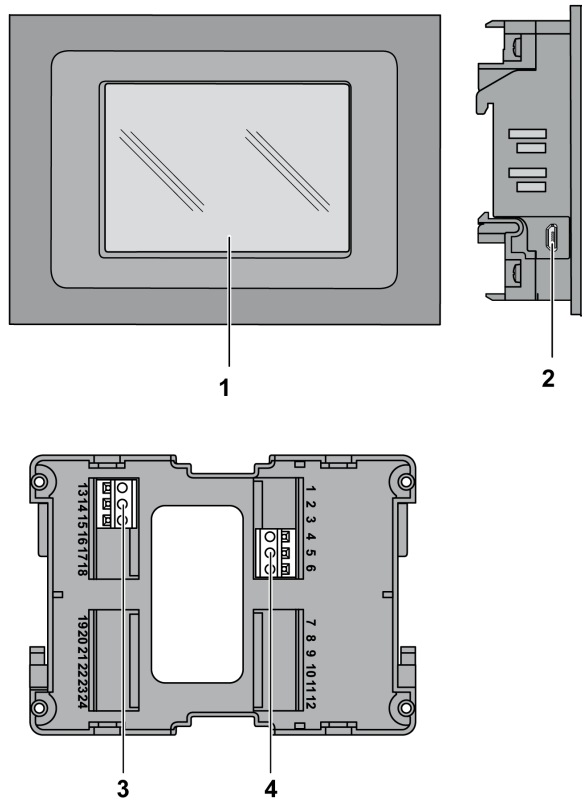

Number	Description
1	Touchscreen
2	USB Micro-B port
3	Power supply connector
4	RS-485 Modbus SL connector

Dimension

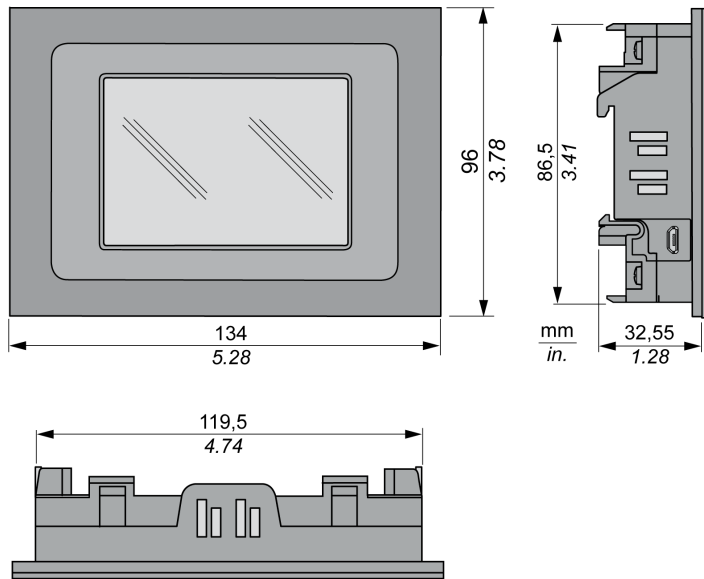

---

# Chapter 12

## Electrical Characteristics and Wiring Diagrams

---

### What Is in This Chapter?

This chapter contains the following topics:

Topic	Page
Power Supply	128
Embedded Sensors	129
RS-485 Modbus Serial Port	130

## Power Supply

### TM172DCL\*\*\*\* Power Supply

References	Power supply characteristics
TM172DCLWT TM172DCLWTH TM172DCLWTHP TM172DCLFW TM172DCLFG	24 Vac (+/- 15 %) non-isolated - 50/60 Hz 24 Vdc (+/- 10 %) non-isolated 3.2 VA / 1.3 W maximum power consumption

Power supply wiring diagram:

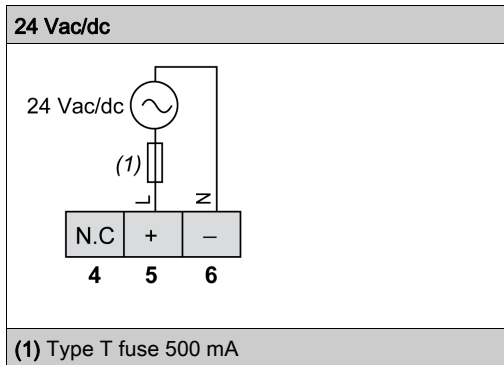

Pitch of the terminal block	Cabling length
5.00 mm (0.197 in.)	10 m (32.808 ft)

## NOTICE

### INOPERABLE EQUIPMENT

Do not connect a power cable longer than 10 m (32.8 ft).

**Failure to follow these instructions can result in equipment damage.**

For more information about the wiring, refer to Best wiring practices ([see page 29](#)).

The power supplies for the TM172DCL\*\*\*\* must be rated Safety Extra Low Voltage (SELV) according to IEC 61140. These sources of power are isolated between the electrical input and output circuits of the power supply as well as simple separation from ground (earth), PELV, and other SELV systems.

## ⚠ DANGER

### GROUND LOOP CAUSING ELECTRIC SHOCK AND/OR INOPERABLE EQUIPMENT

Do not connect the 0 V power supply/transformer connection supplying this equipment to any external ground (earth) connection.

**Failure to follow these instructions will result in death or serious injury.**

In all cases, if the specified voltage range is not maintained, the products may not function as intended. Use appropriate safety interlocks and voltage monitoring circuits.

## ⚠ WARNING

### POTENTIAL OF OVERHEATING AND FIRE

- Do not connect the equipment directly to line voltage.
- Use only isolating SELV, Class 2 power supplies / transformers to supply power to this equipment.

**Failure to follow these instructions can result in death, serious injury, or equipment damage.**



## Embedded Sensors

### TM172DCLWT•• Embedded Temperature Sensor Characteristics

Characteristic	Value
Type	10 k NTC type 2 thermistor
Resolution	+/- 0.1 °C (+/- 0.2 °F)
Measurement range	-40...+50 °C (-40...+122 °F)
Accuracy	+/- 0.5 °C (+/- 0.9 °F) at 21 °C (70 °F) typical calibration

### TM172DCLWTH• Embedded Humidity Sensors Characteristics

Characteristic	Value
Type and calibration	Single point calibrated bulk polymer
Precision	Reading range from 10...90 % R.H. non-condensing 10...20 % precision: 10 % 20...80 % precision: 5 % 80...90 % precision: 10 %
Stability	Less than 1.0 % yearly (typical drift)

## RS-485 Modbus Serial Port

### Overview

The TM172DCL\*\*\*\* can be connected to the controller through the RS-485 Modbus.  
For details, refer to RS-485 Serial port description of the controller (*see page 107*).

### Connector

RS-485 connector (CN3):

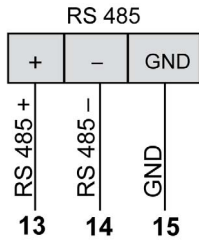

**NOTE:** GND of the RS-485 terminal is not internally connected to the “-” of the power supply terminal of the device.

### Architecture Wiring Examples

The following diagram shows an RS-485 (field) architecture wiring example:

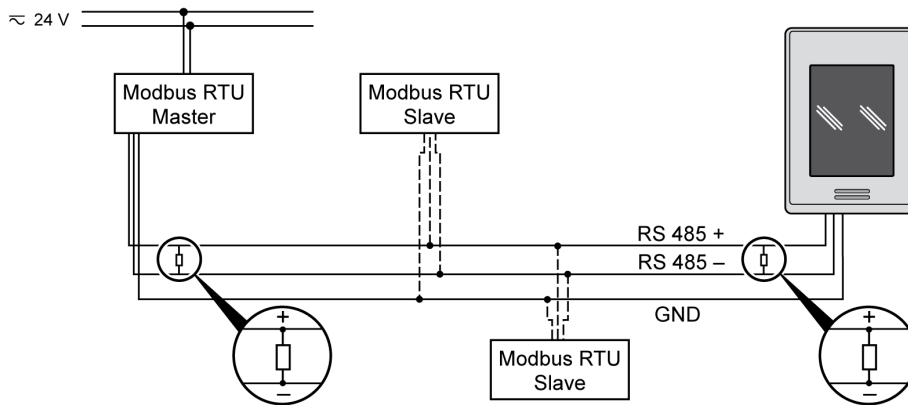

---

## Part V

### Parameters

---



---

# Chapter 13

## Parameters

---

### What Is in This Chapter?

This chapter contains the following topics:

Topic	Page
Overview	134
Controller Parameter Table	136
Expansion Module Parameters Table	150
Display Color Touchscreen Parameters Table	158

## Overview

### Overview

Parameters are used to configure a Modicon M172 Logic Controller.

They can be modified with:

- Keys on:
  - TM172•D••••• front panel
  - TM172DCL••••• remote displays
- PC with EcoStruxure Machine Expert - HVAC software (TM171SW)
- Modbus SL communication

 **WARNING**

**UNINTENDED EQUIPMENT OPERATION**

After any BIOS parameter modification, power cycle the device.

**Failure to follow these instructions can result in death, serious injury, or equipment damage.**

### Modbus Commands and Data Areas

The following commands are implemented:

Modbus command	Description
3 (3 <sub>h</sub> )	Read multiple registers on Client side
6 (6 <sub>h</sub> )	Write single register on Client side
16 (10 <sub>h</sub> )	Write multiple registers on Client side
43 (2B <sub>h</sub> )	Read Device Identification: <ul style="list-style-type: none"> <li>● Vendor name</li> <li>● Product code</li> <li>● Major/minor revision</li> </ul>

### Parameters Tables

The three following tables list all information required to read, write, and decode all accessible resources in the device.

- Controller Parameter table *(see page 136)*
- Expansion Module Parameters table *(see page 150)*
- Display Parameter table *(see page 158)*

Description of columns:

Column	Description
LABEL	Indicates the label used to display the parameters in the device menu.
ADDRESS	Indicates the address of the Modbus register containing the resource to access.
DATA TYPE	Indicates the size of the data in bits.
CPL	When the field indicates "-1", the value read by the register requires conversion because the value represents a number with a sign. In the other cases, the value is always positive or null. To carry out the conversion, proceed as follows: <ul style="list-style-type: none"> <li>● If the value in the register is from 0 to 32767, the result is the value itself (zero and positive values).</li> <li>● If the value in the register is from 32768 to 65535, the result is the value of the register - 65536 (negative values).</li> </ul>
RESET	Indicates whether the controller must be rebooted after the parameter has been modified. <ul style="list-style-type: none"> <li>● Y = the controller must be rebooted to modify the parameter.</li> <li>● Empty "-" = the controller does not need to be rebooted to modify the parameter.</li> </ul>
DESCRIPTION	Description of the parameter usage.
RANGE	Describes the interval of values that can be assigned to the parameter. It can be correlated with other equipment parameters (indicated in the parameter label).

---

Column	Description
DEFAULT	Indicates the factory setting for the reference of the device.
U.M.	Indicates the unit of measurement for values converted according to the rules indicated in the CPL column. The unit of measurement shown is for example purposes only, as it may change depending on the application (for example, parameters with a U.M. in °C/bar could also have %RH.)

## Controller Parameter Table

### Folders

**NOTE:** Not all parameters listed are available depending on the accessible resources in the device.  
The following tables present the controller parameters, divided into categories (folders):

Folder label
Acknowledgment ( <i>see page 136</i> )
AI Calibration ( <i>see page 136</i> )
AO Calibration ( <i>see page 136</i> )
Analog Inputs - Base Board ( <i>see page 141</i> )
Analog Inputs - Upper Board ( <i>see page 143</i> )
ON Board <b>RS485-1</b> ( <i>see page 144</i> )
ON Board <b>RS485-2</b> ( <i>see page 144</i> )
ON Board CAN Expansion bus ( <i>see page 145</i> )
RS-485 Passive Communication Module ( <i>see page 145</i> )
CAN Expansion bus Passive Communication Module ( <i>see page 146</i> )
RS-232 Passive Communication Module ( <i>see page 146</i> )
Ethernet ( <i>see page 147</i> )
Display ( <i>see page 148</i> )
BACnet ( <i>see page 148</i> )
FileSystem ( <i>see page 148</i> )
Miscellaneous ( <i>see page 149</i> )

### Acknowledgment Folder

LABEL	ADDRESS	DATA TYPE	CPL	RESET	DESCRIPTION	RANGE	DEFAULT	U.M.
Par_TAB	15716	WORD	-	Y	Map code <b>NOTE:</b> RW parameter	0...65535	0	Num
Par_POLI	15717	WORD	-	Y	Model code <b>NOTE:</b> RW parameter	0...65535	2049	Num
Par_PARMOD	15719	BOOL	-	-	Parameter modified Flag indicating change to default setting: <ul style="list-style-type: none"> <li>0 (false): map not modified</li> <li>1 (true): at least one parameter has been modified with respect to the original configuration</li> </ul>	0...1	0	Num

### AI Calibration Folder

LABEL	ADDRESS	DATA TYPE	CPL	RESET	DESCRIPTION	RANGE	DEFAULT	U.M.
Gain_10V_AI1	15527	WORD	-	-	0...10 V Calibration gain AI1	0...65535	32768	Num
Gain_10V_AI10	15590	WORD	-	-	0...10 V Calibration gain AI10	0...65535	32768	Num
Gain_10V_AI11	15597	WORD	-	-	0...10 V Calibration gain AI11	0...65535	32768	Num
Gain_10V_AI12	15604	WORD	-	-	0...10 V Calibration gain AI12	0...65535	32768	Num
Gain_10V_AI2	15534	WORD	-	-	0...10 V Calibration gain AI2	0...65535	32768	Num



LABEL	ADDRESS	DATA TYPE	CPL	RESET	DESCRIPTION	RANGE	DEFAULT	U.M.
Gain_10V_AI3	15541	WORD	-	-	0...10 V Calibration gain AI3	0...65535	32768	Num
Gain_10V_AI4	15548	WORD	-	-	0...10 V Calibration gain AI4	0...65535	32768	Num
Gain_10V_AI5	15555	WORD	-	-	0...10 V Calibration gain AI5	0...65535	32768	Num
Gain_10V_AI6	15562	WORD	-	-	0...10 V Calibration gain AI6	0...65535	32768	Num
Gain_10V_AI7	15569	WORD	-	-	0...10 V Calibration gain AI7	0...65535	32768	Num
Gain_10V_AI8	15576	WORD	-	-	0...10 V Calibration gain AI8	0...65535	32768	Num
Gain_10V_AI9	15583	WORD	-	-	0...10 V Calibration gain AI9	0...65535	32768	Num
Gain_5V_AI1	15526	WORD	-	-	0...5 V Calibration gain AI1	0...65535	32768	Num
Gain_5Vr_AI1	15529	WORD	-	-	0...5 V <sub>ratiometric</sub> Calibration gain AI1	0...65535	32768	Num
Gain_5V_AI10	15589	WORD	-	-	0...5 V Calibration gain AI10	0...65535	32768	Num
Gain_5Vr_AI10	15592	WORD	-	-	0...5 V <sub>ratiometric</sub> Calibration gain AI10	0...65535	32768	Num
Gain_5V_AI11	15596	WORD	-	-	0...5 V Calibration gain AI11	0...65535	32768	Num
Gain_5Vr_AI11	15599	WORD	-	-	0...5 V <sub>ratiometric</sub> Calibration gain AI11	0...65535	32768	Num
Gain_5V_AI12	15603	WORD	-	-	0...5 V Calibration gain AI12	0...65535	32768	Num
Gain_5Vr_AI12	15606	WORD	-	-	0...5 V <sub>ratiometric</sub> Calibration gain AI12	0...65535	32768	Num
Gain_5V_AI2	15533	WORD	-	-	0...5 V Calibration gain AI2	0...65535	32768	Num
Gain_5Vr_AI2	15536	WORD	-	-	0...5 V <sub>ratiometric</sub> Calibration gain AI2	0...65535	32768	Num
Gain_5V_AI3	15540	WORD	-	-	0...5 V Calibration gain AI3	0...65535	32768	Num
Gain_5Vr_AI3	15543	WORD	-	-	0...5 V <sub>ratiometric</sub> Calibration gain AI3	0...65535	32768	Num
Gain_5V_AI4	15547	WORD	-	-	0...5 V Calibration gain AI4	0...65535	32768	Num
Gain_5Vr_AI4	15550	WORD	-	-	0...5 V <sub>ratiometric</sub> Calibration gain AI4	0...65535	32768	Num
Gain_5V_AI5	15554	WORD	-	-	0...5 V Calibration gain AI5	0...65535	32768	Num
Gain_5Vr_AI5	15557	WORD	-	-	0...5 V <sub>ratiometric</sub> Calibration gain AI5	0...65535	32768	Num
Gain_5V_AI6	15561	WORD	-	-	0...5 V Calibration gain AI6	0...65535	32768	Num
Gain_5Vr_AI6	15564	WORD	-	-	0...5 V <sub>ratiometric</sub> Calibration gain AI6	0...65535	32768	Num
Gain_5V_AI7	15568	WORD	-	-	0...5 V Calibration gain AI7	0...65535	32768	Num
Gain_5Vr_AI7	15571	WORD	-	-	0...5 V <sub>ratiometric</sub> Calibration gain AI7	0...65535	32768	Num
Gain_5V_AI8	15575	WORD	-	-	0...5 V Calibration gain AI8	0...65535	32768	Num
Gain_5Vr_AI8	15578	WORD	-	-	0...5 V <sub>ratiometric</sub> Calibration gain AI8	0...65535	32768	Num
Gain_5V_AI9	15582	WORD	-	-	0...5 V Calibration gain AI9	0...65535	32768	Num
Gain_5Vr_AI9	15585	WORD	-	-	0...5 V <sub>ratiometric</sub> Calibration gain AI9	0...65535	32768	Num
Gain_mA_AI1	15528	WORD	-	-	0/4...20 mA Calibration gain AI1	0...65535	32768	Num
Gain_mA_AI10	15591	WORD	-	-	0/4...20 mA Calibration gain AI10	0...65535	32768	Num
Gain_mA_AI11	15598	WORD	-	-	0/4...20 mA Calibration gain AI11	0...65535	32768	Num
Gain_mA_AI12	15605	WORD	-	-	0/4...20 mA Calibration gain AI12	0...65535	32768	Num
Gain_mA_AI2	15535	WORD	-	-	0/4...20 mA Calibration gain AI2	0...65535	32768	Num
Gain_mA_AI3	15542	WORD	-	-	0/4...20 mA Calibration gain AI3	0...65535	32768	Num
Gain_mA_AI4	15549	WORD	-	-	0/4...20 mA Calibration gain AI4	0...65535	32768	Num
Gain_mA_AI5	15556	WORD	-	-	0/4...20 mA Calibration gain AI5	0...65535	32768	Num
Gain_mA_AI6	15563	WORD	-	-	0/4...20 mA Calibration gain AI6	0...65535	32768	Num
Gain_mA_AI7	15570	WORD	-	-	0/4...20 mA Calibration gain AI7	0...65535	32768	Num
Gain_mA_AI8	15577	WORD	-	-	0/4...20 mA Calibration gain AI8	0...65535	32768	Num
Gain_mA_AI9	15584	WORD	-	-	0/4...20 mA Calibration gain AI9	0...65535	32768	Num
Gain_Ntc_AI1	15524	WORD	-	-	NTC Calibration gain AI1	0...65535	32768	Num
Gain_Ntc_AI10	15587	WORD	-	-	NTC Calibration gain AI10	0...65535	32768	Num

LABEL	ADDRESS	DATA TYPE	CPL	RESET	DESCRIPTION	RANGE	DEFAULT	U.M.
Gain_Ntc_AI11	15594	WORD	-	-	NTC Calibration gain AI11	0...65535	32768	Num
Gain_Ntc_AI12	15601	WORD	-	-	NTC Calibration gain AI12	0...65535	32768	Num
Gain_Ntc_AI2	15531	WORD	-	-	NTC Calibration gain AI2	0...65535	32768	Num
Gain_Ntc_AI3	15538	WORD	-	-	NTC Calibration gain AI3	0...65535	32768	Num
Gain_Ntc_AI4	15545	WORD	-	-	NTC Calibration gain AI4	0...65535	32768	Num
Gain_Ntc_AI5	15552	WORD	-	-	NTC Calibration gain AI5	0...65535	32768	Num
Gain_Ntc_AI6	15559	WORD	-	-	NTC Calibration gain AI6	0...65535	32768	Num
Gain_Ntc_AI7	15566	WORD	-	-	NTC Calibration gain AI7	0...65535	32768	Num
Gain_Ntc_AI8	15573	WORD	-	-	NTC Calibration gain AI8	0...65535	32768	Num
Gain_Ntc_AI9	15580	WORD	-	-	NTC Calibration gain AI9	0...65535	32768	Num
Gain_Pt1000_AI1	15525	WORD	-	-	Pt1000 Calibration gain AI1	0...65535	32768	Num
Gain_Pt1000_AI10	15588	WORD	-	-	Pt1000 Calibration gain AI10	0...65535	32768	Num
Gain_Pt1000_AI11	15595	WORD	-	-	Pt1000 Calibration gain AI11	0...65535	32768	Num
Gain_Pt1000_AI12	15602	WORD	-	-	Pt1000 Calibration gain AI12	0...65535	32768	Num
Gain_Pt1000_AI2	15532	WORD	-	-	Pt1000 Calibration gain AI2	0...65535	32768	Num
Gain_Pt1000_AI3	15539	WORD	-	-	Pt1000 Calibration gain AI3	0...65535	32768	Num
Gain_Pt1000_AI4	15546	WORD	-	-	Pt1000 Calibration gain AI4	0...65535	32768	Num
Gain_Pt1000_AI5	15553	WORD	-	-	Pt1000 Calibration gain AI5	0...65535	32768	Num
Gain_Pt1000_AI6	15560	WORD	-	-	Pt1000 Calibration gain AI6	0...65535	32768	Num
Gain_Pt1000_AI7	15567	WORD	-	-	Pt1000 Calibration gain AI7	0...65535	32768	Num
Gain_Pt1000_AI8	15574	WORD	-	-	Pt1000 Calibration gain AI8	0...65535	32768	Num
Gain_Pt1000_AI9	15581	WORD	-	-	Pt1000 Calibration gain AI9	0...65535	32768	Num
Gain_PTC_AI1	15530	WORD	-	-	PTC Calibration gain AI1	0...65535	32768	Num
Gain_PTC_AI10	15593	WORD	-	-	PTC Calibration gain AI10	0...65535	32768	Num
Gain_PTC_AI11	15600	WORD	-	-	PTC Calibration gain AI11	0...65535	32768	Num
Gain_PTC_AI12	15607	WORD	-	-	PTC Calibration gain AI12	0...65535	32768	Num
Gain_PTC_AI2	15537	WORD	-	-	PTC Calibration gain AI2	0...65535	32768	Num
Gain_PTC_AI3	15544	WORD	-	-	PTC Calibration gain AI3	0...65535	32768	Num
Gain_PTC_AI4	15551	WORD	-	-	PTC Calibration gain AI4	0...65535	32768	Num
Gain_PTC_AI5	15558	WORD	-	-	PTC Calibration gain AI5	0...65535	32768	Num
Gain_PTC_AI6	15565	WORD	-	-	PTC Calibration gain AI6	0...65535	32768	Num
Gain_PTC_AI7	15572	WORD	-	-	PTC Calibration gain AI7	0...65535	32768	Num
Gain_PTC_AI8	15579	WORD	-	-	PTC Calibration gain AI8	0...65535	32768	Num
Gain_PTC_AI9	15586	WORD	-	-	PTC Calibration gain AI9	0...65535	32768	Num
Offs_Ntc_AI1	15608	WORD	-1	-	NTC Calibration offset AI1	-32768...32767	0	Num
Offs_Pt1000_AI1	15609	WORD	-1	-	Pt1000 Calibration offset AI1	-32768...32767	0	Num
Offs_5V_AI1	15610	WORD	-1	-	0...5 V Calibration offset AI1	-32768...32767	0	Num
Offs_10V_AI1	15611	WORD	-1	-	0...10 V Calibration offset AI1	-32768...32767	0	Num
Offs_mA_AI1	15612	WORD	-1	-	0/4...20 mA Calibration offset AI1	-32768...32767	0	Num
Offs_5Vr_AI1	15613	WORD	-1	-	0...5 V <sub>ratiometric</sub> Calibration offset AI1	-32768...32767	0	Num
Offs_PTC_AI1	15614	WORD	-1	-	PTC Calibration offset AI1	-32768...32767	0	Num
Offs_Ntc_AI2	15615	WORD	-1	-	NTC Calibration offset AI2	-32768...32767	0	Num
Offs_Pt1000_AI2	15616	WORD	-1	-	Pt1000 Calibration offset AI2	-32768...32767	0	Num
Offs_5V_AI2	15617	WORD	-1	-	0...5 V Calibration offset AI2	-32768...32767	0	Num
Offs_10V_AI2	15618	WORD	-1	-	0...10 V Calibration offset AI2	-32768...32767	0	Num
Offs_mA_AI2	15619	WORD	-1	-	0/4...20 mA Calibration offset AI2	-32768...32767	0	Num

LABEL	ADDRESS	DATA TYPE	CPL	RESET	DESCRIPTION	RANGE	DEFAULT	U.M.
Offs_5Vr_AI2	15620	WORD	-1	-	0...5 V <sub>ratiometric</sub> Calibration offset AI2	-32768...32767	0	Num
Offs_PTC_AI2	15621	WORD	-1	-	PTC Calibration offset AI2	-32768...32767	0	Num
Offs_Ntc_AI3	15622	WORD	-1	-	NTC Calibration offset AI3	-32768...32767	0	Num
Offs_Pt1000_AI3	15623	WORD	-1	-	Pt1000 Calibration offset AI3	-32768...32767	0	Num
Offs_5V_AI3	15624	WORD	-1	-	0...5 V Calibration offset AI3	-32768...32767	0	Num
Offs_10V_AI3	15625	WORD	-1	-	0...10 V Calibration offset AI3	-32768...32767	0	Num
Offs_mA_AI3	15626	WORD	-1	-	0/4...20 mA Calibration offset AI3	-32768...32767	0	Num
Offs_5Vr_AI3	15627	WORD	-1	-	0...5 V <sub>ratiometric</sub> Calibration offset AI3	-32768...32767	0	Num
Offs_PTC_AI3	15628	WORD	-1	-	PTC Calibration offset AI3	-32768...32767	0	Num
Offs_Ntc_AI4	15629	WORD	-1	-	NTC Calibration offset AI4	-32768...32767	0	Num
Offs_Pt1000_AI4	15630	WORD	-1	-	Pt1000 Calibration offset AI4	-32768...32767	0	Num
Offs_5V_AI4	15631	WORD	-1	-	0...5 V Calibration offset AI4	-32768...32767	0	Num
Offs_10V_AI4	15632	WORD	-1	-	0...10 V Calibration offset AI4	-32768...32767	0	Num
Offs_mA_AI4	15633	WORD	-1	-	0/4...20 mA Calibration offset AI4	-32768...32767	0	Num
Offs_5Vr_AI4	15634	WORD	-1	-	0...5 V <sub>ratiometric</sub> Calibration offset AI4	-32768...32767	0	Num
Offs_PTC_AI4	15635	WORD	-1	-	PTC Calibration offset AI4	-32768...32767	0	Num
Offs_Ntc_AI5	15636	WORD	-1	-	NTC Calibration offset AI5	-32768...32767	0	Num
Offs_Pt1000_AI5	15637	WORD	-1	-	Pt1000 Calibration offset AI5	-32768...32767	0	Num
Offs_5V_AI5	15638	WORD	-1	-	0...5 V Calibration offset AI5	-32768...32767	0	Num
Offs_10V_AI5	15639	WORD	-1	-	0...10 V Calibration offset AI5	-32768...32767	0	Num
Offs_mA_AI5	15640	WORD	-1	-	0/4...20 mA Calibration offset AI5	-32768...32767	0	Num
Offs_5Vr_AI5	15641	WORD	-1	-	0...5 V <sub>ratiometric</sub> Calibration offset AI5	-32768...32767	0	Num
Offs_PTC_AI5	15642	WORD	-1	-	PTC Calibration offset AI5	-32768...32767	0	Num
Offs_Ntc_AI6	15643	WORD	-1	-	NTC Calibration offset AI6	-32768...32767	0	Num
Offs_Pt1000_AI6	15644	WORD	-1	-	Pt1000 Calibration offset AI6	-32768...32767	0	Num
Offs_5V_AI6	15645	WORD	-1	-	0...5 V Calibration offset AI6	-32768...32767	0	Num
Offs_10V_AI6	15646	WORD	-1	-	0...10 V Calibration offset AI6	-32768...32767	0	Num
Offs_mA_AI6	15647	WORD	-1	-	0/4...20 mA Calibration offset AI6	-32768...32767	0	Num
Offs_5Vr_AI6	15648	WORD	-1	-	0...5 V <sub>ratiometric</sub> Calibration offset AI6	-32768...32767	0	Num
Offs_PTC_AI6	15649	WORD	-1	-	PTC Calibration offset AI6	-32768...32767	0	Num
Offs_Ntc_AI7	15650	WORD	-1	-	NTC Calibration offset AI7	-32768...32767	0	Num
Offs_Pt1000_AI7	15651	WORD	-1	-	Pt1000 Calibration offset AI7	-32768...32767	0	Num
Offs_5V_AI7	15652	WORD	-1	-	0...5 V Calibration offset AI7	-32768...32767	0	Num
Offs_10V_AI7	15653	WORD	-1	-	0...10 V Calibration offset AI7	-32768...32767	0	Num
Offs_mA_AI7	15654	WORD	-1	-	0/4...20 mA Calibration offset AI7	-32768...32767	0	Num
Offs_5Vr_AI7	15655	WORD	-1	-	0...5 V <sub>ratiometric</sub> Calibration offset AI7	-32768...32767	0	Num
Offs_PTC_AI7	15656	WORD	-1	-	PTC Calibration offset AI7	-32768...32767	0	Num
Offs_Ntc_AI8	15657	WORD	-1	-	NTC Calibration offset AI8	-32768...32767	0	Num
Offs_Pt1000_AI8	15658	WORD	-1	-	Pt1000 Calibration offset AI8	-32768...32767	0	Num
Offs_5V_AI8	15659	WORD	-1	-	0...5 V Calibration offset AI8	-32768...32767	0	Num
Offs_10V_AI8	15660	WORD	-1	-	0...10 V Calibration offset AI8	-32768...32767	0	Num
Offs_mA_AI8	15661	WORD	-1	-	0/4...20 mA Calibration offset AI8	-32768...32767	0	Num
Offs_5Vr_AI8	15662	WORD	-1	-	0...5 V <sub>ratiometric</sub> Calibration offset AI8	-32768...32767	0	Num
Offs_PTC_AI8	15663	WORD	-1	-	PTC Calibration offset AI8	-32768...32767	0	Num
Offs_Ntc_AI9	15664	WORD	-1	-	NTC Calibration offset AI9	-32768...32767	0	Num
Offs_Pt1000_AI9	15665	WORD	-1	-	Pt1000 Calibration offset AI9	-32768...32767	0	Num

LABEL	ADDRESS	DATA TYPE	CPL	RESET	DESCRIPTION	RANGE	DEFAULT	U.M.
Offs_5V_AI9	15666	WORD	-1	-	0...5 V Calibration offset AI9	-32768...32767	0	Num
Offs_10V_AI9	15667	WORD	-1	-	0...10 V Calibration offset AI9	-32768...32767	0	Num
Offs_mA_AI9	15668	WORD	-1	-	0/4...20 mA Calibration offset AI9	-32768...32767	0	Num
Offs_5Vr_AI9	15669	WORD	-1	-	0...5 V <sub>ratiometric</sub> Calibration offset AI9	-32768...32767	0	Num
Offs_PTC_AI9	15670	WORD	-1	-	PTC Calibration offset AI9	-32768...32767	0	Num
Offs_Ntc_AI10	15671	WORD	-1	-	NTC Calibration offset AI10	-32768...32767	0	Num
Offs_Pt1000_AI10	15672	WORD	-1	-	Pt1000 Calibration offset AI10	-32768...32767	0	Num
Offs_5V_AI10	15673	WORD	-1	-	0...5 V Calibration offset AI10	-32768...32767	0	Num
Offs_10V_AI10	15674	WORD	-1	-	0...10 V Calibration offset AI10	-32768...32767	0	Num
Offs_mA_AI10	15675	WORD	-1	-	0/4...20 mA Calibration offset AI10	-32768...32767	0	Num
Offs_5Vr_AI10	15676	WORD	-1	-	0...5 V <sub>ratiometric</sub> Calibration offset AI10	-32768...32767	0	Num
Offs_PTC_AI10	15677	WORD	-1	-	PTC Calibration offset AI10	-32768...32767	0	Num
Offs_Ntc_AI11	15678	WORD	-1	-	NTC Calibration offset AI11	-32768...32767	0	Num
Offs_Pt1000_AI11	15679	WORD	-1	-	Pt1000 Calibration offset AI11	-32768...32767	0	Num
Offs_5V_AI11	15680	WORD	-1	-	0...5 V Calibration offset AI11	-32768...32767	0	Num
Offs_10V_AI11	15681	WORD	-1	-	0...10 V Calibration offset AI11	-32768...32767	0	Num
Offs_mA_AI11	15682	WORD	-1	-	0/4...20 mA Calibration offset AI11	-32768...32767	0	Num
Offs_5Vr_AI11	15683	WORD	-1	-	0...5 V <sub>ratiometric</sub> Calibration offset AI11	-32768...32767	0	Num
Offs_PTC_AI11	15684	WORD	-1	-	PTC Calibration offset AI11	-32768...32767	0	Num
Offs_Ntc_AI12	15685	WORD	-1	-	NTC Calibration offset AI12	-32768...32767	0	Num
Offs_Pt1000_AI12	15686	WORD	-1	-	Pt1000 Calibration offset AI12	-32768...32767	0	Num
Offs_5V_AI12	15687	WORD	-1	-	0...5 V Calibration offset AI12	-32768...32767	0	Num
Offs_10V_AI12	15688	WORD	-1	-	0...10 V Calibration offset AI12	-32768...32767	0	Num
Offs_mA_AI12	15689	WORD	-1	-	0/4...20 mA Calibration offset AI12	-32768...32767	0	Num
Offs_5Vr_AI12	15690	WORD	-1	-	0...5 V <sub>ratiometric</sub> Calibration offset AI12	-32768...32767	0	Num
Offs_PTC_AI12	15691	WORD	-1	-	PTC Calibration offset AI12	-32768...32767	0	Num

AO Calibration Folder

LABEL	ADDRESS	DATA TYPE	CPL	RESET	DESCRIPTION	RANGE	DEFAULT	U.M.
Gain_10V_AO1	15692	WORD	-	-	0...10 V Calibration gain AO1	0...65535	32768	Num
Gain_10V_AO2	15694	WORD	-	-	0...10 V Calibration gain AO2	0...65535	32768	Num
Gain_10V_AO3	15696	WORD	-	-	0...10 V Calibration gain AO3	0...65535	32768	Num
Gain_10V_AO4	15698	WORD	-	-	0...10 V Calibration gain AO4	0...65535	32768	Num
Gain_10V_AO5	15700	WORD	-	-	0...10 V Calibration gain AO5	0...65535	32768	Num
Gain_10V_AO6	15702	WORD	-	-	0...10 V Calibration gain AO6	0...65535	32768	Num
Gain_mA_AO1	-	-	-	-	Not used	-	-	-
Gain_mA_AO2	-	-	-	-	Not used	-	-	-
Gain_mA_AO3	15697	WORD	-	-	0/4...20 mA Calibration gain AO3	0...65535	32768	Num
Gain_mA_AO4	15699	WORD	-	-	0/4...20 mA Calibration gain AO4	0...65535	32768	Num
Gain_mA_AO5	-	-	-	-	Not used	-	-	-
Gain_mA_AO6	-	-	-	-	Not used	-	-	-
Offs_10V_AO1	15704	WORD	-1	-	0...10 V Calibration offset AO1	-32768...32767	0	Num

LABEL	ADDRESS	DATA TYPE	CPL	RESET	DESCRIPTION	RANGE	DEFAULT	U.M.
Offs_mA_AO1	15705	WORD	-1	-	0/4...20 mA Calibration offset AO1	-32768...32767	0	Num
Offs_10V_AO2	15706	WORD	-1	-	0...10 V Calibration offset AO2	-32768...32767	0	Num
Offs_mA_AO2	15707	WORD	-1	-	0/4...20 mA Calibration offset AO2	-32768...32767	0	Num
Offs_10V_AO3	15708	WORD	-1	-	0...10 V Calibration offset AO3	-32768...32767	0	Num
Offs_mA_AO3	15709	WORD	-1	-	0/4...20 mA Calibration offset AO3	-32768...32767	0	Num
Offs_10V_AO4	15710	WORD	-1	-	0...10 V Calibration offset AO4	-32768...32767	0	Num
Offs_mA_AO4	15711	WORD	-1	-	0/4...20 mA Calibration offset AO4	-32768...32767	0	Num
Offs_10V_AO5	15712	WORD	-1	-	0...10 V Calibration offset AO5	-32768...32767	0	Num
Offs_mA_AO5	15713	WORD	-1	-	0/4...20mA Calibration offset AO5	-32768...32767	0	Num
Offs_10V_AO6	15714	WORD	-1	-	0...10V Calibration offset AO6	-32768...32767	0	Num
Offs_mA_AO6	15715	WORD	-1	-	0/4...20mA Calibration offset AO6	-32768...32767	0	Num

### Analog Inputs - Base Board Folder

LABEL	ADDRESS	DATA TYPE	CPL	RESET	DESCRIPTION	RANGE	DEFAULT	U.M.
Temp_UM	15725	WORD	-	-	Temperature unit of measurement <ul style="list-style-type: none"> <li>● 0 = °C</li> <li>● 1 = °F</li> </ul>	0, 1	0	Num
Cfg_Ai1	15726	WORD	-	-	Type of analog input Ai1 <ul style="list-style-type: none"> <li>● 0 = NTC (NK103)</li> <li>● 1 = DI Input</li> <li>● 2 = NTC (103AT)</li> <li>● 3 = 4...20 mA</li> <li>● 4 = 0...10 V</li> <li>● 5 = 0...5 V (Ratiometric)</li> <li>● 6 = Pt1000</li> <li>● 7 = hΩ(NTC)</li> <li>● 8 = daΩ(Pt1000)</li> <li>● 9 = PTC</li> <li>● 10 = 0...5 V</li> <li>● 11 = 0...20 mA</li> </ul>	0...11	2	Num
Cfg_Ai2	15727	WORD	-	-	Type of analog input Ai2 See Cfg_Ai1	0...11	2	Num
Cfg_Ai3	15728	WORD	-	-	Type of analog input Ai3 See Cfg_Ai1	0...11	2	Num
Cfg_Ai4	15729	WORD	-	-	Type of analog input Ai4 See Cfg_Ai1	0...11	2	Num
Cfg_Ai5	15730	WORD	-	-	Type of analog input Ai5 See Cfg_Ai1	0...11	2	Num
Cfg_Ai6	15731	WORD	-	-	Type of analog input Ai6 See Cfg_Ai1	0...11	2	Num
Cfg_Ai7	16100	WORD	-	-	Type of analog input Ai7 See Cfg_Ai1	0...11	2	Num
Cfg_Ai8	16101	WORD	-	-	Type of analog input Ai8 See Cfg_Ai1	0...11	2	Num

LABEL	ADDRESS	DATA TYPE	CPL	RESET	DESCRIPTION	RANGE	DEFAULT	U.M.
FullScaleMin_Ai1	15736	WORD	-1	-	Analog input Ai1 start of scale value <b>NOTE:</b> Minimum full scale: for current probes, value at 4 mA, for 0...10 V voltage probes, value at 0 V, for ratiometric probes (0...5 V), value at 10% (corresponding to 0.5 V).	-9999...+9999	0	Num
FullScaleMax_Ai1	15737	WORD	-1	-	Analog input Ai1 full scale value <b>NOTE:</b> Maximum full scale for current probes, value at 20 mA, for 0...10 V voltage probes, value at 10 V, for ratiometric probes (0...5 V), value at 90% (corresponding to 4.5 V).	-9999...+9999	1000	Num
FullScaleMin_Ai2	15738	WORD	-1	-	Analog input Ai2 start of scale value See FullScaleMin_Ai1	-9999...+9999	0	Num
FullScaleMax_Ai2	15739	WORD	-1	-	Analog input Ai2 full scale value See FullScaleMax_Ai1	-9999...+9999	1000	Num
FullScaleMin_Ai3	15740	WORD	-1	-	Analog input Ai3 start of scale value See FullScaleMin_Ai1	-9999...+9999	0	Num
FullScaleMax_Ai3	15741	WORD	-1	-	Analog input Ai3 full scale value See FullScaleMax_Ai1	-9999...+9999	1000	Num
FullScaleMin_Ai4	15742	WORD	-1	-	Analog input Ai4 start of scale value See FullScaleMin_Ai1	-9999...+9999	0	Num
FullScaleMax_Ai4	15743	WORD	-1	-	Analog input Ai4 full scale value See FullScaleMax_Ai1	-9999...+9999	1000	Num
FullScaleMin_Ai5	15744	WORD	-1	-	Analog input Ai5 start of scale value See FullScaleMin_Ai1	-9999...+9999	0	Num
FullScaleMax_Ai5	15745	WORD	-1	-	Analog input Ai5 full scale value See FullScaleMax_Ai1	-9999...+9999	1000	Num
FullScaleMin_Ai6	15746	WORD	-1	-	Analog input Ai6 start of scale value See FullScaleMin_Ai1	-9999...+9999	0	Num
FullScaleMaxAi6	15747	WORD	-1	-	Analog input Ai6 full scale value See FullScaleMax_Ai1	-9999...+9999	1000	Num
FullScaleMin_Ai7	16106	WORD	-1	-	Analog input Ai7 start of scale value See FullScaleMin_Ai1	-9999...+9999	0	Num
FullScaleMax_Ai7	16107	WORD	-1	-	Analog input Ai7 full scale value See FullScaleMax_Ai1	-9999...+9999	1000	Num
FullScaleMin_Ai8	16108	WORD	-1	-	Analog input Ai8 start of scale value See FullScaleMin_Ai1	-9999...+9999	0	Num
FullScaleMaxAi8	16109	WORD	-1	-	Analog input Ai8 full scale value See FullScaleMax_Ai1	-9999...+9999	1000	Num
Calibration_Ai1	15748	WORD	-1	-	Analog input Ai1 differential	-1000...1000	0	Digit
Calibration_Ai2	15749	WORD	-1	-	Analog input Ai2 differential	-1000...1000	0	Digit
Calibration_Ai3	15750	WORD	-1	-	Analog input Ai3 differential	-1000...1000	0	Digit
Calibration_Ai4	15751	WORD	-1	-	Analog input Ai4 differential	-1000...1000	0	Digit
Calibration_Ai5	15752	WORD	-1	-	Analog input Ai5 differential	-1000...1000	0	Digit
Calibration_Ai6	15753	WORD	-1	-	Analog input Ai6 differential	-1000...1000	0	Digit
Calibration_Ai7	16118	WORD	-1	-	Analog input Ai7 differential	-1000...1000	0	Digit
Calibration_Ai8	16119	WORD	-1	-	Analog input Ai8 differential	-1000...1000	0	Digit
Cfg_AO3	15758	WORD	-	-	Type of analog output AO3 <ul style="list-style-type: none"> <li>● 0 = current modulation</li> <li>● 1 = current ON/OFF</li> <li>● 2 = voltage modulation</li> <li>● 3 = PWM mode</li> </ul>	0...3	0	Num

LABEL	ADDRESS	DATA TYPE	CPL	RESET	DESCRIPTION	RANGE	DEFAULT	U.M.
Cfg_AO4	15759	WORD	-	-	Type of analog output AO4 See Cfg_AO3	0...3	0	Num
PWM_frequency_AO3_AO4	15769	WORD	-	Y	PWM Frequency for AO3 and AO4 in PWM mode	0...2000	1000	Hz
PWM_polarity_AO3_AO4	15770	WORD	-	-	PWM Polarity for AO3 and AO4 in PWM mode: 1 = direct,0 = reversed	0, 1	1	Num

### Analog Inputs - Upper Board Folder

LABEL	ADDRESS	DATA TYPE	CPL	RESET	DESCRIPTION	RANGE	DEFAULT	U.M.
Cfg_Ai9	16102	WORD	-	-	Type of analog input Ai9 <ul style="list-style-type: none"> <li>● 0 = NTC (NK103)</li> <li>● 1 = DI Input</li> <li>● 2 = NTC (103AT)</li> <li>● 3 = 4...20 mA</li> <li>● 4 = 0...10 V</li> <li>● 5 = 0...5 V (Ratiometric)</li> <li>● 6 = Pt1000</li> <li>● 7 = hΩ(NTC)</li> <li>● 8 = daΩ(Pt1000)</li> <li>● 9 = PTC</li> <li>● 10 = 0...5 V</li> <li>● 11 = 0...20 mA</li> </ul>	0...11	3	Num
Cfg_Ai10	16103	WORD	-	-	Type of analog input Ai10 See Cfg_Ai1	0...11	3	Num
Cfg_Ai11	16104	WORD	-	-	Type of analog input Ai11 See Cfg_Ai1	0...11	3	Num
Cfg_Ai12	16105	WORD	-	-	Type of analog input Ai12 See Cfg_Ai1	0...11	3	Num
FullScaleMin_Ai9	16110	WORD	-1	-	Analog input Ai9 start of scale value <b>NOTE:</b> Minimum full scale: for current probes, value at 4 mA, for 0...10 V voltage probes, value at 0 V, for ratiometric probes (0...5 V), value at 10% (corresponding to 0.5 V).	-9999...+9999	0	Num
FullScaleMax_Ai9	16111	WORD	-1	-	Analog input Ai9 full scale value <b>NOTE:</b> Maximum full scale for current probes, value at 20 mA, for 0...10 V voltage probes, value at 10 V, for ratiometric probes (0...5 V), value at 90% (corresponding to 4.5 V).	-9999...+9999	1000	Num
FullScaleMin_Ai10	16112	WORD	-1	-	Analog input Ai10 start of scale value See FullScaleMin_Ai1	-9999...+9999	0	Num
FullScaleMax_Ai10	16113	WORD	-1	-	Analog input Ai10 full scale value See FullScaleMax_Ai1	-9999...+9999	1000	Num
FullScaleMin_Ai11	16114	WORD	-1	-	Analog input Ai11 start of scale value See FullScaleMin_Ai1	-9999...+9999	0	Num
FullScaleMax_Ai11	16115	WORD	-1	-	Analog input Ai11 full scale value See FullScaleMax_Ai1	-9999...+9999	1000	Num
FullScaleMin_Ai12	16116	WORD	-1	-	Analog input Ai12 start of scale value See FullScaleMin_Ai1	-9999...+9999	0	Num

LABEL	ADDRESS	DATA TYPE	CPL	RESET	DESCRIPTION	RANGE	DEFAULT	U.M.
FullScaleMax_Ai12	16117	WORD	-1	-	Analog input Ai12 full scale value See FullScaleMax_Ai1	-9999...+9999	1000	Num
Calibration_Ai9	16120	WORD	-1	-	Analog input Ai9 differential	-1000...1000	0	Digit
Calibration_Ai10	16121	WORD	-1	-	Analog input Ai10 differential	-1000...1000	0	Digit
Calibration_Ai11	16122	WORD	-1	-	Analog input Ai11 differential	-1000...1000	0	Digit
Calibration_Ai12	16123	WORD	-1	-	Analog input Ai12 differential	-1000...1000	0	Digit

### ON Board RS485-1 Folder

LABEL	ADDRESS	DATA TYPE	CPL	RESET	DESCRIPTION	RANGE	DEFAULT	U.M.
Addr_RS485_OB1	16124	WORD	-	Y	On-board RS-485 serial address	0... 255	1	Num
Proto_RS485_OB1	16125	WORD	-	Y	On-board RS-485 protocol selection <ul style="list-style-type: none"> <li>● 2 = uNET</li> <li>● 3 = Modbus/RTU</li> </ul>	2, 3	3	Num
Databit_RS485_OB1	16126	WORD	-	Y	On-board RS-485 data bit number Fixed setting 8	8	8	Num
Stopbit_RS485_OB1	16127	WORD	-	Y	On-board RS-485 stop bit number <ul style="list-style-type: none"> <li>● 1 = 1 stop bit</li> <li>● 2 = 2 stop bit</li> </ul>	1, 2	1	Num
Parity_RS485_OB1	16128	WORD	-	Y	On-board RS-485 protocol parity <ul style="list-style-type: none"> <li>● 0 = NULL</li> <li>● 1 = ODD</li> <li>● 2 = EVEN</li> </ul>	0...2	2	Num
Baud_RS485_OB1	16129	WORD	-	Y	On-board RS-485 protocol baudrate <ul style="list-style-type: none"> <li>● 0 = 9600 baud</li> <li>● 1 = 19200 baud</li> <li>● 2 = 38400 baud</li> <li>● 3 = 57600 baud</li> <li>● 4 = 76800 baud</li> <li>● 5 = 115200 baud</li> </ul>	0...5	2	Num

### ON Board RS485-2 Folder

LABEL	ADDRESS	DATA TYPE	CPL	RESET	DESCRIPTION	RANGE	DEFAULT	U.M.
Addr_RS485_OB	15774	WORD	-	Y	On-board RS-485 serial address	0...255	1	Num
Proto_RS485_OB	15775	WORD	-	Y	On-board RS-485 protocol selection <ul style="list-style-type: none"> <li>● 2 = uNET</li> <li>● 3 = Modbus/RTU</li> </ul>	2, 3	3	Num
Databit_RS485_OB	15776	WORD	-	Y	On-board RS-485 data bit number Fixed setting 8	8	8	Num
Stopbit_RS485_OB	15777	WORD	-	Y	On-board RS-485 stop bit number <ul style="list-style-type: none"> <li>● 1 = 1 stop bit</li> <li>● 2 = 2 stop bit</li> </ul>	1, 2	1	Num



LABEL	ADDRESS	DATA TYPE	CPL	RESET	DESCRIPTION	RANGE	DEFAULT	U.M.
Parity_RS485_OB	15778	WORD	-	Y	On-board RS-485 protocol parity <ul style="list-style-type: none"> <li>● 0 = NULL</li> <li>● 1 = ODD</li> <li>● 2 = EVEN</li> </ul>	0...2	2	Num
Baud_RS485_OB	15779	WORD	-	Y	On-board RS-485 protocol baudrate <ul style="list-style-type: none"> <li>● 0 = 9600 baud</li> <li>● 1 = 19200 baud</li> <li>● 2 = 38400 baud</li> <li>● 3 = 57600 baud</li> <li>● 4 = 76800 baud</li> <li>● 5 = 115200 baud</li> </ul>			

### ON Board CAN Expansion Bus Folder

LABEL	ADDRESS	DATA TYPE	CPL	RESET	DESCRIPTION	RANGE	DEFAULT	U.M.
Addr_CAN_OB	15780	WORD	-	Y	On-board CAN Expansion bus serial address	1...127	1	Num
Baud_CAN_OB	15781	WORD	-	Y	On-board CAN Expansion protocol baudrate <ul style="list-style-type: none"> <li>● 2 = 500 kBd</li> <li>● 3 = 250 kBd</li> <li>● 4 = 125 kBd</li> <li>● 5 = 125 kBd</li> <li>● 6 = 50 kBd</li> </ul>	2...6	2	Num

### RS-485 Passive Communication Module Folder

LABEL	ADDRESS	DATA TYPE	CPL	RESET	DESCRIPTION	RANGE	DEFAULT	U.M.
Addr_RS485_PI	15782	WORD	-	Y	RS-485 Passive Communication Module serial address	0...255	1	Num
Proto_RS485_PI	15783	WORD	-	Y	RS-485 Passive Communication Module protocol selection <ul style="list-style-type: none"> <li>● 2 = uNET</li> <li>● 3 = Modbus/RTU</li> </ul>	2, 3	3	Num
Databit_RS485_PI	15784	WORD	-	Y	RS-485 Passive Communication Module data bit number Fixed setting 8	8	8	Num
Stopbit_RS485_PI	15785	WORD	-	Y	RS-485 Passive Communication Module stop bit number <ul style="list-style-type: none"> <li>● 1 = 1 stop bit</li> <li>● 2 = 2 stop bit</li> </ul>	1, 2	1	Num
Parity_RS485_PI	15786	WORD	-	Y	RS-485 Passive Communication Module protocol parity <ul style="list-style-type: none"> <li>● 0 = NULL</li> <li>● 1 = ODD</li> <li>● 2 = EVEN</li> </ul>	0...2	2	Num

LABEL	ADDRESS	DATA TYPE	CPL	RESET	DESCRIPTION	RANGE	DEFAULT	U.M.
Baud_RS485_PI	15787	WORD	-	Y	RS-485 Passive Communication Module protocol baudrate <ul style="list-style-type: none"> <li>● 0 = 9600 baud</li> <li>● 1 = 19200 baud</li> <li>● 2 = 38400 baud</li> <li>● 3 = 57600 baud</li> <li>● 4 = 76800 baud</li> <li>● 5 = 115200 baud</li> </ul>	0...5	2	Num

### CAN Expansion Bus Passive Communication Module Folder

LABEL	ADDRESS	DATA TYPE	CPL	RESET	DESCRIPTION	RANGE	DEFAULT	U.M.
Addr_CAN_PI	15788	WORD	-	Y	CAN Expansion bus Passive Communication Module serial address	1...127	1	Num
Baud_CAN_PI	15789	WORD	-	Y	CAN Expansion bus Passive Communication Module protocol baudrate <ul style="list-style-type: none"> <li>● 2 = 500 kBd</li> <li>● 3 = 250 kBd</li> <li>● 4 = 125 kBd</li> <li>● 5 = 125 kBd</li> <li>● 6 = 50 kBd</li> </ul>	2...6	2	Num

### RS-232 Passive Communication Module Folder

LABEL	ADDRESS	DATA TYPE	CPL	RESET	DESCRIPTION	RANGE	DEFAULT	U.M.
Addr_RS232_PI	15790	WORD	-	Y	RS-232 passive Communication Module serial address	0...255	1	Num
Proto_RS232_PI	15791	WORD	-	Y	RS-232 Passive Communication Module protocol selection <ul style="list-style-type: none"> <li>● 2 = uNET</li> <li>● 3 = Modbus/RTU</li> </ul>	2...3	3	Num
Databit_RS232_PI	15792	WORD	-	Y	RS-232 Passive Communication Module data bit number <ul style="list-style-type: none"> <li>● 7 = 7 bit</li> <li>● 8 = 8 bit</li> </ul>	7...8	8	Num
Stopbit_RS232_PI	15793	WORD	-	Y	RS-232 Passive Communication Module stop bit number <ul style="list-style-type: none"> <li>● 1 = 1 stop bit</li> <li>● 2 = 2 stop bit</li> </ul>	1...2	1	Num
Parity_RS232_PI	15784	WORD	-	Y	RS-232 Passive Communication Module protocol parity <ul style="list-style-type: none"> <li>● 0 = NULL</li> <li>● 1 = ODD</li> <li>● 2 = EVEN</li> </ul>	0...2	2	Num

LABEL	ADDRESS	DATA TYPE	CPL	RESET	DESCRIPTION	RANGE	DEFAULT	U.M.
Baud_RS232_PI	15795	WORD	-	Y	RS-232 Passive Communication Module protocol baudrate <ul style="list-style-type: none"> <li>● 0 = 9600 baud</li> <li>● 1 = 19200 baud</li> <li>● 2 = 38400 baud</li> <li>● 3 = 57600 baud</li> <li>● 4 = 76800 baud</li> <li>● 5 = 115200 baud</li> </ul>	0...5	2	Num

### Ethernet Folder

LABEL	ADDRESS	DATA TYPE	CPL	RESET	DESCRIPTION	RANGE	DEFAULT	U.M.
Port_FTP_PI	15772	WORD	-	Y	FTP Port number Default 0 corresponds to port 21	0...65535	0	Num
Port_HTTP_PI	15796	WORD	-	Y	HTTP port HTTP communication Port number Default 0 corresponds to port 80	0...65535	0	Num
Port_ETH_PI	15797	WORD	-	Y	Port TCP/IP Modbus communication port.	0...65535	502	Num
Ip_1_ETH_PI	15798	WORD	-	Y	Ethernet passive Plug-in IP address (part 1)	0...255	10	Num
Ip_2_ETH_PI	15799	WORD	-	Y	Ethernet passive Plug-in IP address (part 2)	0...255	0	Num
Ip_3_ETH_PI	15800	WORD	-	Y	Ethernet passive Plug-in IP address (part 3)	0...255	0	Num
Ip_4_ETH_PI	15801	WORD	-	Y	Ethernet passive Plug-in IP address (part 4)	0...255	100	Num
DefGtwy_1_ETH_PI	15802	WORD	-	Y	Default gateway (part 1)	0...255	10	Num
DefGtwy_2_ETH_PI	15803	WORD	-	Y	Default gateway (part 2)	0...255	0	Num
DefGtwy_3_ETH_PI	15804	WORD	-	Y	Default gateway (part 3)	0...255	0	Num
DefGtwy_4_ETH_PI	15805	WORD	-	Y	Default gateway (part 4)	0...255	1	Num
NetMsk_1_ETH_PI	15806	WORD	-	Y	Net mask (part 1)	0...255	255	Num
NetMsk_2_ETH_PI	15807	WORD	-	Y	Net mask (part 2)	0...255	255	Num
NetMsk_3_ETH_PI	15808	WORD	-	Y	Net mask (part 3)	0...255	255	Num
NetMsk_4_ETH_PI	15809	WORD	-	Y	Net mask (part 4)	0...255	0	Num
PriDNS_1_ETH_PI	15810	WORD	-	Y	Primary DNS server (part 1)	0...255	8	Num
PriDNS_2_ETH_PI	15811	WORD	-	Y	Primary DNS server (part 2)	0...255	8	Num
PriDNS_3_ETH_PI	15812	WORD	-	Y	Primary DNS server (part 3)	0...255	8	Num
PriDNS_4_ETH_PI	15813	WORD	-	Y	Primary DNS server (part 4)	0...255	8	Num
SecDNS_1_ETH_PI	15814	WORD	-	Y	Secondary DNS server (part 1)	0...255	8	Num
SecDNS_2_ETH_PI	15815	WORD	-	Y	Secondary DNS server (part 2)	0...255	8	Num
SecDNS_3_ETH_PI	15816	WORD	-	Y	Secondary DNS server (part 3)	0...255	4	Num
SecDNS_4_ETH_PI	15817	WORD	-	Y	Secondary DNS server (part 4)	0...255	4	Num
EnableDHCP_ETH_PI	15818	WORD	-	Y	Enable DHCP 0 = False, 1 = True	0, 1	0	Flag
MAC_1_ETH_PI	16130	WORD	-	Y	MAC address (first part)	0	0	Num
MAC_2_ETH_PI	16131	WORD	-	Y	MAC address (second part)	0...24	24	Num
MAC_3_ETH_PI	16132	WORD	-	Y	MAC address (third part)	0...187	187	Num

LABEL	ADDRESS	DATA TYPE	CPL	RESET	DESCRIPTION	RANGE	DEFAULT	U.M.
MAC_4_ETH_PI	16133	WORD	-	Y	MAC address (fourth part)	0...255	255	Num
MAC_5_ETH_PI	16134	WORD	-	Y	MAC address (fifth part)	0...255	255	Num

### Display Folder

LABEL	ADDRESS	DATA TYPE	CPL	RESET	DESCRIPTION	RANGE	DEFAULT	U.M.
Hmi_Language	15819	WORD	-	Y	Language	0...65535	0	Num
Par_ContrLCD	15723	WORD	-	Y	LCD contrast	0...63	30	Num
Par_BackLightTime	15724	WORD	-	Y	Backlight time	0...3600	10	Sec

### BACnet Folder

LABEL	ADDRESS	DATA TYPE	CPL	RESET	DESCRIPTION	RANGE	DEFAULT	U.M.
Load_BACnet_E2_Defaults	15766	WORD	-	Y	Load default values for BACnet parameters in EEPROM at next boot	0...1	1	Flag
Port_BACnet_IP	15768	WORD	-	Y	BACnet/IP Port number. 0 = default port 47808, 65535 = BACnet stack running only on PLC side	0...65535	0	Num

### FileSystem Volumes

LABEL	ADDRESS	DATA TYPE	CPL	RESET	DESCRIPTION	RANGE	DEFAULT	U.M.
HTTP_volume	16136	WORD	-	Y	Volume of HTTP files 0 = NOR Flash 1 = micro SD card	0, 1	0	Num
DAT_volume	16137	WORD	-	Y	Volume of *.DAT and *.RAW files 0 = NOR Flash 1 = micro SD card	0, 1	0	Num
PLC_volume	16139	WORD	-	Y	Volume of PLC file 0 = NOR Flash 1 = micro SD card	0, 1	0	Num
HMI_volume	16140	WORD	-	Y	Volume of HMI file 0 = NOR Flash 1 = micro SD card	0, 1	0	Num
REM_volume	16141	WORD	-	Y	Volume of HMI Remote file 0 = NOR Flash 1 = micro SD card	0, 1	0	Num
PAR_volume	16142	WORD	-	Y	Volume of CONNEC.PAR file 0 = NOR Flash 1 = micro SD card	0, 1	0	Num

## Miscellaneous

LABEL	ADDRESS	DATA TYPE	CPL	RESET	DESCRIPTION	RANGE	DEFAULT	U.M.
virtualDipSwitch	16143	WORD	-	Y	Numeric prefix for system files name	0...7	0	Num

## Expansion Module Parameters Table

### Folders

**NOTE:** Not all parameters listed are available depending on the accessible resources in the device.

The following tables present the Expansion module parameters, divided into categories (folders):

Folder label
Acknowledgment ( <i>see page 150</i> )
AI Calibration ( <i>see page 150</i> )
AO Calibration ( <i>see page 153</i> )
Analog Inputs - Base Board ( <i>see page 154</i> )
Analog Inputs - Upper Board ( <i>see page 155</i> )
Analog Outputs Upper Board Folder ( <i>see page 156</i> )
ON Board CAN Expansion bus ( <i>see page 157</i> )

### Acknowledgment Folder

LABEL	ADDRESS	DATA TYPE	CPL	RESET	DESCRIPTION	RANGE	DEFAULT	U.M.
Par_TAB	15716	WORD	-	Y	Map code <b>NOTE:</b> read/write parameter	0...65535	0	Num
Par_POLI	15717	WORD	-	Y	Model Code <b>NOTE:</b> read/write parameter	0...65535	2049	Num
Par_PCH	15719	BOOL	-	-	Device model <b>NOTE:</b> read/write parameter	0...65535	324	Num

### AI Calibration Folder

LABEL	ADDRESS	DATA TYPE	CPL	RESET	DESCRIPTION	RANGE	DEFAULT	U.M.
Gain_10V_AI1	15527	WORD	-	-	0...10 V calibration gain AI1	0...65535	32768	Num
Gain_10V_AI10	15590	WORD	-	-	0...10 V calibration gain AI10	0...65535	32768	Num
Gain_10V_AI2	15534	WORD	-	-	0...10 V calibration gain AI2	0...65535	32768	Num
Gain_10V_AI3	15541	WORD	-	-	0...10 V calibration gain AI3	0...65535	32768	Num
Gain_10V_AI4	15548	WORD	-	-	0...10 V calibration gain AI4	0...65535	32768	Num
Gain_10V_AI5	15555	WORD	-	-	0...10 V calibration gain AI5	0...65535	32768	Num
Gain_10V_AI6	15562	WORD	-	-	0...10 V calibration gain AI6	0...65535	32768	Num
Gain_10V_AI7	15569	WORD	-	-	0...10 V calibration gain AI7	0...65535	32768	Num
Gain_10V_AI8	15576	WORD	-	-	0...10 V calibration gain AI8	0...65535	32768	Num
Gain_10V_AI9	15583	WORD	-	-	0...10 V calibration gain AI9	0...65535	32768	Num
Gain_5Vr_AI1	15526	WORD	-	-	0...5 V <sub>ratiometric</sub> calibration gain AI1	0...65535	32768	Num
Gain_5V_AI1	15529	WORD	-	-	0...5 V calibration gain AI1	0...65535	32768	Num
Gain_5Vr_AI10	15589	WORD	-	-	0...5 V <sub>ratiometric</sub> calibration gain AI10	0...65535	32768	Num
Gain_5V_AI10	15592	WORD	-	-	0...5 V calibration gain AI10	0...65535	32768	Num
Gain_5Vr_AI2	15533	WORD	-	-	0...5 V <sub>ratiometric</sub> calibration gain AI2	0...65535	32768	Num
Gain_5V_AI2	15536	WORD	-	-	0...5 V calibration gain AI2	0...65535	32768	Num
Gain_5Vr_AI3	15540	WORD	-	-	0...5 V <sub>ratiometric</sub> calibration gain AI3	0...65535	32768	Num

LABEL	ADDRESS	DATA TYPE	CPL	RESET	DESCRIPTION	RANGE	DEFAULT	U.M.
Gain_5V_AI3	15543	WORD	-	-	0...5 V calibration gain AI3	0...65535	32768	Num
Gain_5Vr_AI4	15547	WORD	-	-	0...5 V <sub>ratiometric</sub> calibration gain AI4	0...65535	32768	Num
Gain_5V_AI4	15550	WORD	-	-	0...5 V calibration gain AI4	0...65535	32768	Num
Gain_5Vr_AI5	15554	WORD	-	-	0...5 V <sub>ratiometric</sub> calibration gain AI5	0...65535	32768	Num
Gain_5V_AI5	15557	WORD	-	-	0...5 V calibration gain AI5	0...65535	32768	Num
Gain_5Vr_AI6	15561	WORD	-	-	0...5 V <sub>ratiometric</sub> calibration gain AI6	0...65535	32768	Num
Gain_5V_AI6	15564	WORD	-	-	0...5 V calibration gain AI6	0...65535	32768	Num
Gain_5Vr_AI7	15568	WORD	-	-	0...5 V <sub>ratiometric</sub> calibration gain AI7	0...65535	32768	Num
Gain_5V_AI7	15571	WORD	-	-	0...5 V calibration gain AI7	0...65535	32768	Num
Gain_5Vr_AI8	15575	WORD	-	-	0...5 V <sub>ratiometric</sub> calibration gain AI8	0...65535	32768	Num
Gain_5V_AI8	15578	WORD	-	-	0...5 V calibration gain AI8	0...65535	32768	Num
Gain_5Vr_AI9	15582	WORD	-	-	0...5 V <sub>ratiometric</sub> calibration gain AI9	0...65535	32768	Num
Gain_5V_AI9	15585	WORD	-	-	0...5 V calibration gain AI9	0...65535	32768	Num
Gain_mA_AI1	15528	WORD	-	-	0/4...20 mA calibration gain AI1	0...65535	32768	Num
Gain_mA_AI10	15591	WORD	-	-	0/4...20 mA calibration gain AI10	0...65535	32768	Num
Gain_mA_AI2	15535	WORD	-	-	0/4...20 mA calibration gain AI2	0...65535	32768	Num
Gain_mA_AI3	15542	WORD	-	-	0/4...20 mA calibration gain AI3	0...65535	32768	Num
Gain_mA_AI4	15549	WORD	-	-	0/4...20 mA calibration gain AI4	0...65535	32768	Num
Gain_mA_AI5	15556	WORD	-	-	0/4...20 mA calibration gain AI5	0...65535	32768	Num
Gain_mA_AI6	15563	WORD	-	-	0/4...20 mA calibration gain AI6	0...65535	32768	Num
Gain_mA_AI7	15570	WORD	-	-	0/4...20 mA calibration gain AI7	0...65535	32768	Num
Gain_mA_AI8	15577	WORD	-	-	0/4...20 mA calibration gain AI8	0...65535	32768	Num
Gain_mA_AI9	15584	WORD	-	-	0/4...20 mA calibration gain AI9	0...65535	32768	Num
Gain_Ntc_AI1	15524	WORD	-	-	NTC calibration gain AI1	0...65535	32768	Num
Gain_Ntc_AI10	15587	WORD	-	-	NTC calibration gain AI10	0...65535	32768	Num
Gain_Ntc_AI2	15531	WORD	-	-	NTC calibration gain AI2	0...65535	32768	Num
Gain_Ntc_AI3	15538	WORD	-	-	NTC calibration gain AI3	0...65535	32768	Num
Gain_Ntc_AI4	15545	WORD	-	-	NTC calibration gain AI4	0...65535	32768	Num
Gain_Ntc_AI5	15552	WORD	-	-	NTC calibration gain AI5	0...65535	32768	Num
Gain_Ntc_AI6	15559	WORD	-	-	NTC calibration gain AI6	0...65535	32768	Num
Gain_Ntc_AI7	15566	WORD	-	-	NTC calibration gain AI7	0...65535	32768	Num
Gain_Ntc_AI8	15573	WORD	-	-	NTC calibration gain AI8	0...65535	32768	Num
Gain_Ntc_AI9	15580	WORD	-	-	NTC calibration gain AI9	0...65535	32768	Num
Gain_Pt1000_AI1	15525	WORD	-	-	Pt1000 calibration gain AI1	0...65535	32768	Num
Gain_Pt1000_AI10	15588	WORD	-	-	Pt1000 calibration gain AI10	0...65535	32768	Num
Gain_Pt1000_AI2	15532	WORD	-	-	Pt1000 calibration gain AI2	0...65535	32768	Num
Gain_Pt1000_AI3	15539	WORD	-	-	Pt1000 calibration gain AI3	0...65535	32768	Num
Gain_Pt1000_AI4	15546	WORD	-	-	Pt1000 calibration gain AI4	0...65535	32768	Num
Gain_Pt1000_AI5	15553	WORD	-	-	Pt1000 calibration gain AI5	0...65535	32768	Num
Gain_Pt1000_AI6	15560	WORD	-	-	Pt1000 calibration gain AI6	0...65535	32768	Num
Gain_Pt1000_AI7	15567	WORD	-	-	Pt1000 calibration gain AI7	0...65535	32768	Num
Gain_Pt1000_AI8	15574	WORD	-	-	Pt1000 calibration gain AI8	0...65535	32768	Num
Gain_Pt1000_AI9	15581	WORD	-	-	Pt1000 calibration gain AI9	0...65535	32768	Num
Gain_PTC_AI1	15530	WORD	-	-	PTC calibration gain AI1	0...65535	32768	Num
Gain_PTC_AI10	15593	WORD	-	-	PTC calibration gain AI10	0...65535	32768	Num
Gain_PTC_AI2	15537	WORD	-	-	PTC calibration gain AI2	0...65535	32768	Num

LABEL	ADDRESS	DATA TYPE	CPL	RESET	DESCRIPTION	RANGE	DEFAULT	U.M.
Gain_PTC_AI3	15544	WORD	-	-	PTC calibration gain AI3	0...65535	32768	Num
Gain_PTC_AI4	15551	WORD	-	-	PTC calibration gain AI4	0...65535	32768	Num
Gain_PTC_AI5	15558	WORD	-	-	PTC calibration gain AI5	0...65535	32768	Num
Gain_PTC_AI6	15565	WORD	-	-	PTC calibration gain AI6	0...65535	32768	Num
Gain_PTC_AI7	15572	WORD	-	-	PTC calibration gain AI7	0...65535	32768	Num
Gain_PTC_AI8	15579	WORD	-	-	PTC calibration gain AI8	0...65535	32768	Num
Gain_PTC_AI9	15586	WORD	-	-	PTC calibration gain AI9	0...65535	32768	Num
Offs_Ntc_AI1	15608	WORD	-1	-	NTC calibration offset AI1	-32768...32767	0	Num
Offs_Pt1000_AI1	15609	WORD	-1	-	Pt1000 calibration offset AI1	-32768...32767	0	Num
Offs_5V_AI1	15610	WORD	-1	-	0...5 V calibration offset AI1	-32768...32767	0	Num
Offs_10V_AI1	15611	WORD	-1	-	0...10 V calibration offset AI1	-32768...32767	0	Num
Offs_mA_AI1	15612	WORD	-1	-	0/4...20 mA calibration offset AI1	-32768...32767	0	Num
Offs_5V_AI1	15613	WORD	-1	-	0...5 V calibration offset AI1	-32768...32767	0	Num
Offs_PTC_AI1	15614	WORD	-1	-	PTC calibration offset AI1	-32768...32767	0	Num
Offs_Ntc_AI2	15615	WORD	-1	-	NTC calibration offset AI2	-32768...32767	0	Num
Offs_Pt1000_AI2	15616	WORD	-1	-	Pt1000 calibration offset AI2	-32768...32767	0	Num
Offs_5V_AI2	15617	WORD	-1	-	0...5 V calibration offset AI2	-32768...32767	0	Num
Offs_10V_AI2	15618	WORD	-1	-	0...10 V calibration offset AI2	-32768...32767	0	Num
Offs_mA_AI2	15619	WORD	-1	-	0/4...20 mA calibration offset AI2	-32768...32767	0	Num
Offs_5V_AI2	15620	WORD	-1	-	0...5 V calibration offset AI2	-32768...32767	0	Num
Offs_PTC_AI2	15621	WORD	-1	-	PTC calibration offset AI2	-32768...32767	0	Num
Offs_Ntc_AI3	15622	WORD	-1	-	NTC calibration offset AI3	-32768...32767	0	Num
Offs_5V_AI3	15624	WORD	-1	-	0...5 V calibration offset AI3	-32768...32767	0	Num
Offs_10V_AI3	15625	WORD	-1	-	0...10 V calibration offset AI3	-32768...32767	0	Num
Offs_mA_AI3	15626	WORD	-1	-	0/4...20 mA calibration offset AI3	-32768...32767	0	Num
Offs_5V_AI3	15627	WORD	-1	-	0...5 V calibration offset AI3	-32768...32767	0	Num
Offs_PTC_AI3	15628	WORD	-1	-	PTC calibration offset AI3	-32768...32767	0	Num
Offs_Ntc_AI4	15629	WORD	-1	-	NTC calibration offset AI4	-32768...32767	0	Num
Offs_Pt1000_AI4	15630	WORD	-1	-	Pt1000 calibration offset AI4	-32768...32767	0	Num
Offs_5V_AI4	15631	WORD	-1	-	0...5 V calibration offset AI4	-32768...32767	0	Num
Offs_10V_AI4	15632	WORD	-1	-	0...10 V calibration offset AI4	-32768...32767	0	Num
Offs_5V_AI4	15634	WORD	-1	-	0...5 V calibration offset AI4	-32768...32767	0	Num
Offs_PTC_AI4	15635	WORD	-1	-	PTC calibration offset AI4	-32768...32767	0	Num
Offs_Ntc_AI5	15636	WORD	-1	-	NTC calibration offset AI5	-32768...32767	0	Num
Offs_Pt1000_AI5	15637	WORD	-1	-	Pt1000 calibration offset AI5	-32768...32767	0	Num
Offs_5V_AI5	15638	WORD	-1	-	0...5 V calibration offset AI5	-32768...32767	0	Num
Offs_10V_AI5	15639	WORD	-1	-	0...10 V calibration offset AI5	-32768...32767	0	Num
Offs_mA_AI5	15640	WORD	-1	-	0/4...20 mA calibration offset AI5	-32768...32767	0	Num
Offs_5V_AI5	15641	WORD	-1	-	0...5 V calibration offset AI5	-32768...32767	0	Num
Offs_PTC_AI5	15642	WORD	-1	-	PTC calibration offset AI5	-32768...32767	0	Num
Offs_Ntc_AI6	15643	WORD	-1	-	NTC calibration offset AI6	-32768...32767	0	Num
Offs_5V_AI6	15645	WORD	-1	-	0...5 V calibration offset AI6	-32768...32767	0	Num
Offs_10V_AI6	15646	WORD	-1	-	0...10 V calibration offset AI6	-32768...32767	0	Num
Offs_mA_AI6	15647	WORD	-1	-	0/4...20 mA calibration offset AI6	-32768...32767	0	Num
Offs_5V_AI6	15648	WORD	-1	-	0...5 V calibration offset AI6	-32768...32767	0	Num
Offs_PTC_AI6	15649	WORD	-1	-	PTC calibration offset AI6	-32768...32767	0	Num
Offs_Ntc_AI7	15650	WORD	-1	-	NTC calibration offset AI7	-32768...32767	0	Num



LABEL	ADDRESS	DATA TYPE	CPL	RESET	DESCRIPTION	RANGE	DEFAULT	U.M.
Offs_Pt1000_AI7	15651	WORD	-1	-	Pt1000 calibration offset AI7	-32768...32767	0	Num
Offs_5V_AI7	15652	WORD	-1	-	0...5 V calibration offset AI7	-32768...32767	0	Num
Offs_10V_AI7	15653	WORD	-1	-	0...10 V calibration offset AI7	-32768...32767	0	Num
Offs_mA_AI7	15654	WORD	-1	-	0/4...20 mA calibration offset AI7	-32768...32767	0	Num
Offs_5V_AI7	15655	WORD	-1	-	0...5 V calibration offset AI7	-32768...32767	0	Num
Offs_PTC_AI7	15656	WORD	-1	-	PTC calibration offset AI7	-32768...32767	0	Num
Offs_Ntc_AI8	15657	WORD	-1	-	NTC calibration offset AI8	-32768...32767	0	Num
Offs_Pt1000_AI8	15658	WORD	-1	-	Pt1000 calibration offset AI8	-32768...32767	0	Num
Offs_5V_AI8	15659	WORD	-1	-	0...5 V calibration offset AI8	-32768...32767	0	Num
Offs_10V_AI8	15660	WORD	-1	-	0...10 V calibration offset AI8	-32768...32767	0	Num
Offs_mA_AI8	15661	WORD	-1	-	0/4...20 mA calibration offset AI8	-32768...32767	0	Num
Offs_5V_AI8	15662	WORD	-1	-	0...5 V calibration offset AI8	-32768...32767	0	Num
Offs_Ntc_AI9	15664	WORD	-1	-	NTC calibration offset AI9	-32768...32767	0	Num
Offs_Pt1000_AI9	15665	WORD	-1	-	Pt1000 calibration offset AI9	-32768...32767	0	Num
Offs_5V_AI9	15666	WORD	-1	-	0...5 V calibration offset AI9	-32768...32767	0	Num
Offs_10V_AI9	15667	WORD	-1	-	0...10 V calibration offset AI9	-32768...32767	0	Num
Offs_mA_AI9	15668	WORD	-1	-	0/4...20 mA calibration offset AI9	-32768...32767	0	Num
Offs_5V_AI9	15669	WORD	-1	-	0...5 V calibration offset AI9	-32768...32767	0	Num
Offs_PTC_AI9	15670	WORD	-1	-	PTC calibration offset AI9	-32768...32767	0	Num
Offs_Ntc_AI10	15671	WORD	-1	-	NTC calibration offset AI10	-32768...32767	0	Num
Offs_Pt1000_AI10	15672	WORD	-1	-	Pt1000 calibration offset AI10	-32768...32767	0	Num
Offs_5V_AI10	15673	WORD	-1	-	0...5 V calibration offset AI10	-32768...32767	0	Num
Offs_10V_AI10	15674	WORD	-1	-	0...10 V calibration offset AI10	-32768...32767	0	Num
Offs_mA_AI10	15675	WORD	-1	-	0/4...20 mA calibration offset AI10	-32768...32767	0	Num
Offs_5V_AI10	15676	WORD	-1	-	0...5 V calibration offset AI10	-32768...32767	0	Num
Offs_PTC_AI10	15677	WORD	-1	-	PTC calibration offset AI10	-32768...32767	0	Num

### AO Calibration Folder

LABEL	ADDRESS	DATA TYPE	CPL	RESET	DESCRIPTION	RANGE	DEFAULT	U.M.
Gain_10V_AO1	15692	WORD	-	-	0...10 V calibration gain AO1	0...65535	32768	Num
Gain_10V_AO2	15694	WORD	-	-	0...10 V calibration gain AO2	0...65535	32768	Num
Gain_mA_AO1	15693	WORD	-	-	0/4...20 mA calibration gain AO1	0...65535	32768	Num
Gain_mA_AO2	15695	WORD	-	-	0/4...20 mA calibration gain AO2	0...65535	32768	Num
Offs_mA_AO1	15705	WORD	-1	-	0/4...20 mA calibration offset AO1	-32768...32767	0	Num
Offs_10V_AO2	15706	WORD	-1	-	0...10 V calibration offset AO2	-32768...32767	0	Num
Offs_mA_AO2	15707	WORD	-1	-	0/4...20 mA calibration offset AO2	-32768...32767	0	Num

## Analog Inputs - Base Board Folder

LABEL	ADDRESS	DATA TYPE	CPL	RESET	DESCRIPTION	RANGE	DEFAULT	U.M.
Temp_UM	15725	WORD	-	-	Temperature unit of measurement <ul style="list-style-type: none"> <li>● 0 = °C</li> <li>● 1 = °F</li> </ul>	0, 1	0	Num
Cfg_Ai1	15726	WORD	-	-	Type of analog input Ai1 <ul style="list-style-type: none"> <li>● 0= NTC (NK103)</li> <li>● 1 = DI Input</li> <li>● 2 = NTC (103AT)</li> <li>● 3 = 4...20 mA</li> <li>● 4 = 0...10 V</li> <li>● 5 = 0...5 V (Ratiometric)</li> <li>● 6 = Pt1000</li> <li>● 7 = hΩ(NTC)</li> <li>● 8 = daΩ(Pt1000)</li> <li>● 9 = PTC</li> <li>● 10 = 0...5 V</li> <li>● 11 = 0...20 mA</li> </ul>	0...11	2	Num
Cfg_Ai2	15727	WORD	-	-	Type of analog input Ai2 See Cfg_Ai1	0...11	2	Num
Cfg_Ai3	15728	WORD	-	-	Type of analog input Ai3 See Cfg_Ai1	0...11	2	Num
Cfg_Ai4	15729	WORD	-	-	Type of analog input Ai4 See Cfg_Ai1	0...11	2	Num
FullScaleMin_Ai1	15736	WORD	-	-	Analog input Ai1 start of scale value <b>NOTE:</b> Minimum full scale: for current probes, value at 4 mA, for 0...10 V voltage probes, value at 0 V, for ratiometric probes (0...5 V), value at 10% (corresponding to 0.5 V).	-9999...+9999	0	Digit
FullScaleMax_Ai1	15737	WORD	-1	-	Analog input Ai1 full scale value <b>NOTE:</b> Maximum full scale for current probes, value at 20 mA, for 0...10 V voltage probes, value at 10 V, for ratiometric probes (0...5 V), value at 90% (corresponding to 4.5 V).	-9999...+9999	1000	Digit
FullScaleMin_Ai2	15738	WORD	-1	-	Analog input Ai2 start of scale value See FullScaleMin_Ai1	-9999...+9999	0	Digit
FullScaleMax_Ai2	15739	WORD	-1	-	Analog input Ai2 full scale value See FullScaleMax_Ai1	-9999...+9999	1000	Digit
FullScaleMin_Ai3	15740	WORD	-1	-	Analog input Ai3 start of scale value See FullScaleMin_Ai1	-9999...+9999	0	Digit
FullScaleMax_Ai3	15741	WORD	-1	-	Analog input Ai3 full scale value See FullScaleMax_Ai1	-9999...+9999	1000	Digit
FullScaleMin_Ai4	15742	WORD	-1	-	Analog input Ai4 start of scale value See FullScaleMin_Ai1	-9999...+9999	0	Digit
FullScaleMax_Ai4	15743	WORD	-1	-	Analog input Ai4 full scale value See FullScaleMax_Ai1	-9999...+9999	1000	Digit
Calibration_Ai1	15748	WORD	-1	-	Analog input Ai1 differential	-1000...1000	0	Digit
Calibration_Ai2	15749	WORD	-1	-	Analog input Ai2 differential	-1000...1000	0	Digit
Calibration_Ai3	15750	WORD	-1	-	Analog input Ai3 differential	-1000...1000	0	Digit
Calibration_Ai4	15751	WORD	-1	-	Analog input Ai4 differential	-1000...1000	0	Digit

LABEL	ADDRESS	DATA TYPE	CPL	RESET	DESCRIPTION	RANGE	DEFAULT	U.M.
SubCfg_AI1	16010	WORD	-	-	Sub configuration of analog input AI1 <ul style="list-style-type: none"> <li>0= Low Pass filter disabled, analog value in raw points;</li> <li>1= Low Pass filter disabled, analog value converted;</li> <li>2= Low Pass filter enabled, analog value in raw points;</li> <li>3 = Low Pass filter enabled, analog value converted.</li> </ul>	0...3	3	Num
SubCfg_AI2	16011	WORD	-	-	Sub configuration of analog input AI2 See SubCfg_AI1	0...3	3	Num
SubCfg_AI3	16012	WORD	-	-	Sub configuration of analog input AI3 See SubCfg_AI1	0...3	3	Num
SubCfg_AI4	16013	WORD	-	-	Sub configuration of analog input AI4 See SubCfg_AI1	0...3	3	Num

### Analog Inputs - Upper Board Folder

LABEL	ADDRESS	DATA TYPE	CPL	RESET	DESCRIPTION	RANGE	DEFAULT	U.M.
Cfg_Ai5	15730	WORD	-	-	Type of analog input Ai5 See Cfg_AI1	0...11	2	Num
Cfg_Ai6	15731	WORD	-	-	Type of analog input Ai6 See Cfg_AI1	0...11	2	Num
Cfg_Ai7	16100	WORD	-	-	Type of analog input Ai7 See Cfg_AI1	0...11	2	Num
Cfg_Ai8	16101	WORD	-	-	Type of analog input Ai8 See Cfg_AI1	0...11	2	Num
Cfg_Ai9	16102	WORD	-	-	Type of analog input Ai9 See Cfg_AI1	0...11	3	Num
Cfg_Ai10	16103	WORD	-	-	Type of analog input Ai10 See Cfg_AI1	0...11	3	Num
FullScaleMin_Ai5	15744	WORD	-1	-	Analog input Ai5 start of scale value See FullScaleMin_AI1	-9999...+9999	0	Digit
FullScaleMax_Ai5	15745	WORD	-1	-	Analog input Ai5 full scale value See FullScaleMax_AI1	-9999...+9999	1000	Digit
FullScaleMin_Ai6	15746	WORD	-1	-	Analog input Ai6 start of scale value See FullScaleMin_AI1	-9999...+9999	0	Digit
FullScaleMaxAi6	15747	WORD	-1	-	Analog input Ai6 full scale value See FullScaleMax_AI1	-9999...+9999	1000	Digit
FullScaleMin_Ai7	16106	WORD	-1	-	Analog input Ai7 start of scale value See FullScaleMin_AI1	-9999...+9999	0	Digit
FullScaleMax_Ai7	16107		-1	-	Analog input Ai7 full scale value See FullScaleMax_AI1	-9999...+9999	1000	Digit
FullScaleMin_Ai8	16108		-1	-	Analog input Ai8 start of scale value See FullScaleMin_AI1	-9999...+9999	0	Digit
FullScaleMaxAi8	16109		-1	-	Analog input Ai8 full scale value See FullScaleMax_AI1	-9999...+9999	1000	Digit

LABEL	ADDRESS	DATA TYPE	CPL	RESET	DESCRIPTION	RANGE	DEFAULT	U.M.
FullScaleMin_Ai9	16110		-1	-	Analog input Ai9 start of scale value <b>NOTE:</b> Minimum full scale: current probes, value at 4 mA, for 0...10 V voltage probes, value at 0 V, for ratiometric probes (0...5 V), value at 10% (corresponding to 0.5 V).	-9999...+9999	0	Digit
FullScaleMax_Ai9	16111		-1	-	Analog input Ai9 full scale value <b>NOTE:</b> Maximum full scale current probes, value at 20 mA, for 0...10 V voltage probes, value at 10 V, for ratiometric probes (0...5 V), value at 90% (corresponding to 4.5 V).	-9999...+9999	1000	Digit
FullScaleMin_Ai10	16112		-1	-	Analog input Ai10 start of scale value See FullScaleMin_Ai1	-9999...+9999	0	Digit
FullScaleMax_Ai10	16113		-1	-	Analog input Ai10 full scale value See FullScaleMax_Ai1	-9999...+9999	1000	Digit
Calibration_Ai5	15752		-1	-	Analog input Ai5 differential	-1000...1000	0	Digit
Calibration_Ai6	15753		-1	-	Analog input Ai6 differential	-1000...1000	0	Digit
Calibration_Ai7	16118		-1	-	Analog input Ai7 differential	-1000...1000	0	Digit
Calibration_Ai8	16119		-1	-	Analog input Ai8 differential	-1000...1000	0	Digit
Calibration_Ai9	16120		-1	-	Analog input Ai9 differential	-1000...1000	0	Digit
Calibration_Ai10	16121		-1	-	Analog input Ai10 differential	-1000...1000	0	Digit
SubCfg_AI5	16014		-	-	Sub configuration of analog input AI5 See SubCfg_Ai1	0...3	3	Num
SubCfg_AI6	16015		-	-	Sub configuration of analog input AI6 See SubCfg_Ai1	0...3	3	Num
SubCfg_AI7	16016		-	-	Sub configuration of analog input AI7 See SubCfg_Ai1	0...3	3	Num
SubCfg_AI8	16017		-	-	Sub configuration of analog input AI8 See SubCfg_Ai1	0...3	3	Num
SubCfg_AI9	16018		-	-	Sub configuration of analog input AI9 See SubCfg_Ai1	0...3	3	Num
SubCfg_AI10	16019		-	-	Sub configuration of analog input AI10 See SubCfg_Ai1	0...3	3	Num

### Analog Outputs Upper Board Folder

LABEL	ADDRESS	DATA TYPE	CPL	RESET	DESCRIPTION	RANGE	DEFAULT	U.M.
Cfg_AO1	15758		-	-	Type of analog output AO1 <ul style="list-style-type: none"> <li>● 0= Current modulation</li> <li>● 1 = Current ON/OFF</li> <li>● 2 = Voltage modulation</li> <li>● 3 = PWM mode</li> </ul>	0...3	0	Num
Cfg_AO2	15759		-	-	Type of analog output AO2 See Cfg_AO1	0...3	0	Num
PWM_frequency_AO1_AO2	15769		-	Y	PWM Frequency for AO1 and AO2 in PWM mode	0...2000	1000	Hz
PWM_polarity_AO1_AO2	15770		-	-	PWM Polarity for AO1 and AO2 in PWM mode <ul style="list-style-type: none"> <li>● 0= Reversed</li> <li>● 1 = Direct</li> </ul>	0, 1	1	Num

## ON Board CAN Expansion Bus Folder

LABEL	ADDRESS	DATA TYPE	CPL	RESET	DESCRIPTION	RANGE	DEFAULT	U.M.
Addr_CAN_OB	15780		-	Y	On-board CAN Expansion Bus serial address	1...127	1	Num
SendPeriodFDI1	17000		-	-	Min period of FDI1 transmission: 0 = max frequency	0...65535	65535	ms
SendPeriodFDI2	17001		-	-	Min period of FDI2 transmission: 0 = max frequency	0...65535	65535	ms

## Display Color Touchscreen Parameters Table

### Folders

**NOTE:** Not all parameters listed are available depending on the accessible resources in the device.

The following tables present the Display Color Touchscreen parameters, divided into categories (folders):

Folder label
Acknowledgment ( <i>see page 158</i> )
AI Calibration ( <i>see page 158</i> )
Analog Inputs ( <i>see page 158</i> )
ON Board RS-485 ( <i>see page 159</i> )
Display ( <i>see page 160</i> )
Remote Slave ( <i>see page 159</i> )

### Acknowledgment Folder

LABEL	ADDRESS	DATA TYPE	CPL	RESET	DESCRIPTION	RANGE	DEFAULT	U.M.
Par_TAB	8192	WORD	-	Y	Map code <b>NOTE:</b> read/write parameter	0...65535	0	Num
Par_POLI	8193	WORD	-	Y	Model Code <b>NOTE:</b> read/write parameter	0...65535	0	Num
Par_PARMOD	8194	WORD	-	-	Parameter modified <ul style="list-style-type: none"> <li>● 0 = False</li> <li>● 1 = True</li> </ul>	0, 1	0	Flag

### AI Calibration Folder

LABEL	ADDRESS	DATA TYPE	CPL	RESET	DESCRIPTION	RANGE	DEFAULT	U.M.
CAL_RH_interne	8195		-	-	Calibration value for RH	-	-	-

### Analog Inputs Folder

LABEL	ADDRESS	DATA TYPE	CPL	RESET	DESCRIPTION	RANGE	DEFAULT	U.M.
Temp_UM	8196	WORD	-	-	Unit of temperature measurement <ul style="list-style-type: none"> <li>● 0 = °C</li> <li>● 1 = °F</li> </ul>	0, 1	0	Num
Calibration_NTC	8197	WORD	-	-	NTC differential	-180...180	0	°C/10 (°F/10)
Calibration_RH	8206	WORD	-	-	RH percentage differential	-1000...1000	0	%/10

## ON Board RS-485 Folder

LABEL	ADDRESS	DATA TYPE	CPL	RESET	DESCRIPTION	RANGE	DEFAULT	U.M.
Addr_RS485_OB	8198	WORD	-	Y	RS-485 On-board address	0...247	1	Num
Proto_RS485_OB	8199	WORD	-	-	Modbus working mode ● 0 = Slave ● 1 = Master	0, 1	(1)	Num
DataBit_RS485_OB	8200	WORD	-	Y	RS-485 On-board Data bit number	8	8	Num
StopBit_RS485_OB	8201	WORD	-	Y	RS-485 On-board stop bit number	1, 2	1	Num
Parity_RS485_OB	8202	WORD	-	Y	RS-485 On-board parity protocol ● 0 = Null ● 1 = Odd ● 2 = Even	0...2	2	Num
Baud_RS485_OB	8203	WORD	-	Y	RS-485 On-board baud rate protocol ● 0 = 9600 ● 1 = 19200 ● 2 = 38400 ● 3 = 57600 ● 4 = 115200	0...4	2	Num

(1) TM172DCLWT•: 0, TM172DCLF•: 1

## Remote Slave Folder

LABEL	ADDRESS	DATA TYPE	CPL	RESET	DESCRIPTION	RANGE	DEFAULT	U.M.
RemoteSlave1_addr	8254	WORD	-	Y	Remote slave 1 address	0...247	0	Num
RemoteSlave1_32bit_order	8262	WORD	-	Y	Remote slave 1 MSB and LSB order ● 0 = DWORD register not swapped and REAL register not swapped ● 1 = DWORD register swapped and REAL register not swapped ● 2 = DWORD register not swapped and REAL register swapped ● 3 = DWORD register swapped and REAL register swapped	0...3	0 <sup>(1)</sup>	Num
RemoteSlave2_addr	8255	WORD	-	Y	Remote slave 2 address	0...247	0	Num
RemoteSlave2_32bit_order	8263	WORD	-	Y	Remote slave 2 MSB and LSB order See RemoteSlave1_32bit_order	0...3	0 <sup>(1)</sup>	Num
RemoteSlave3_addr	8256	WORD	-	Y	Remote slave 3 address	0...247	0	Num
RemoteSlave3_32bit_order	8264	WORD	-	Y	Remote slave 3 MSB and LSB order See RemoteSlave1_32bit_order	0...3	0 <sup>(1)</sup>	Num
RemoteSlave4_addr	8257	WORD	-	Y	Remote slave 4 address	0...247	0	Num
RemoteSlave4_32bit_order	8265	WORD	-	Y	Remote slave 4 MSB and LSB order See RemoteSlave1_32bit_order	0...3	0 <sup>(1)</sup>	Num
RemoteSlave5_addr	8258	WORD	-	Y	Remote slave 5 address	0...247	0	Num
RemoteSlave5_32bit_order	8266	WORD	-	Y	Remote slave 5 MSB and LSB order See RemoteSlave1_32bit_order	0...3	0 <sup>(1)</sup>	Num
RemoteSlave6_addr	8259	WORD	-	Y	Remote slave 6 address	0...247	0	Num
RemoteSlave6_32bit_order	8267	WORD	-	Y	Remote slave 6 MSB and LSB order See RemoteSlave1_32bit_order	0...3	0 <sup>(1)</sup>	Num
RemoteSlave7_addr	8260	WORD	-	Y	Remote slave 7 address	0...247	0	Num

(1) 0=Word NOT swapped, 1= Word swapped for WORD, 2= Word swapped for REAL, 3= Word swapped

Parameters

LABEL	ADDRESS	DATA TYPE	CPL	RESET	DESCRIPTION	RANGE	DEFAULT	U.M.
RemoteSlave7_32bit_order	8268	WORD	-	Y	Remote slave 7 MSB and LSB order See RemoteSlave1_32bit_order	0...3	0 <sup>(1)</sup>	Num
RemoteSlave8_addr	8261	WORD	-	Y	Remote slave 8 address	0...247	0	Num
RemoteSlave8_32bit_order	8269	WORD	-	Y	Remote slave 8 MSB and LSB order See RemoteSlave1_32bit_order	0...3	0 <sup>(1)</sup>	Num

(1) 0=Word NOT swapped, 1= Word swapped for WORD, 2= Word swapped for REAL, 3= Word swapped

Display Folder

LABEL	ADDRESS	DATA TYPE	CPL	RESET	DESCRIPTION	RANGE	DEFAULT	U.M.
Par_Orientation	8204	WORD	-	Y	Display orientation <ul style="list-style-type: none"> <li>● 0 = Landscape</li> <li>● 1 = Portrait</li> </ul>	0, 1	0	-
Par_Language	8205	WORD	-	-	System Language	0...65535	1	Num
Par_BackLightTime	8207	WORD	-	-	Backlight time	0...3600	10	Sec
Par_BackLightMinValue	8250	WORD	-	-	Backlight minimum value	0...100	5%	%



---

# Part VI

## Commissioning

---

### What Is in This Part?

This part contains the following chapters:

Chapter	Chapter Name	Page
14	EcoStruxure Machine Expert - HVAC software (TM171SW)	163
15	Connection Types	165
16	BIOS Update	169



---

# Chapter 14

## EcoStruxure Machine Expert - HVAC software (TM171SW)

---

### General Description

#### Overview

The EcoStruxure Machine Expert - HVAC software (TM171SW) development tool makes it possible to create and customize IEC 61131-3 programs for various types of application. You can download EcoStruxure Machine Expert - HVAC software (TM171SW) from [Schneider-electric web site download center](#). It is intended for applications in HVAC&R.

#### EcoStruxure Machine Expert - HVAC software (TM171SW) Software Component

EcoStruxure Machine Expert - HVAC software (TM171SW) permits to:

- Create and manage libraries, applications, and diagnostics.
- Manage previously developed applications, upload/download applications, and modify device parameters from a serial port.

#### PC Connection

M172 can be connected to a PC through the USB port and a USB cable:

- Type A USB (HOST). Used to connect a USB memory key drive when downloading the application.
- Type Mini-B USB (DEVICE). Used to connect TM172P••••• / TM172O••••• to a PC via Mini-B/A USB cable for debugging, commissioning, downloading, and uploading with TM171SW (EcoStruxure Machine Expert - HVAC software).
- Type micro-B USB (DEVICE). Used to connect TM172DCL••••• to a PC via micro-B/A USB cable for debugging, commissioning, downloading, and uploading with TM171SW (EcoStruxure Machine Expert - HVAC software).

The TM172P••••• / TM172O••••• can also be supplied through the USB cable with limited functionalities related to debugging, commissioning, downloading and uploading with TM171SW (EcoStruxure Machine Expert - HVAC software). For more information, refer to the EcoStruxure Machine Expert - HVAC software, Operating Guide.

**NOTE:** Do not apply voltage via 24 Vac/dc while the equipment is already connected to a PC via Mini-B USB cable (TM172P••••• only).

Before applying power via 24 Vac/dc power supply connection:

- Disconnect the Mini-B USB cable.
- Supply the M172 controller via its 24 Vac/dc power supply connector.
- Reconnect the Mini-B USB cable.

**NOTE:** Inactive connections are not closed automatically. If all connections are open and the cable is disconnected, a reconnect is not possible and the controller must be power cycled.

### ***NOTICE***

#### **LOSS OF COMMUNICATION**

- Close all open TCP connections between PC and the controller before disconnecting the Ethernet cable.
- Close all open TCP connections before replacing an Ethernet cable.

**Failure to follow these instructions can result in equipment damage.**



---

# Chapter 15

## Connection Types

---

### What Is in This Chapter?

This chapter contains the following topics:

Topic	Page
Connection with a PC Through USB	166
Connection with a USB Memory Key	167
Connection with a PC Through Ethernet	168

## Connection with a PC Through USB

### Connecting The PC to The Controller

Direct connection between the PC and the controller:

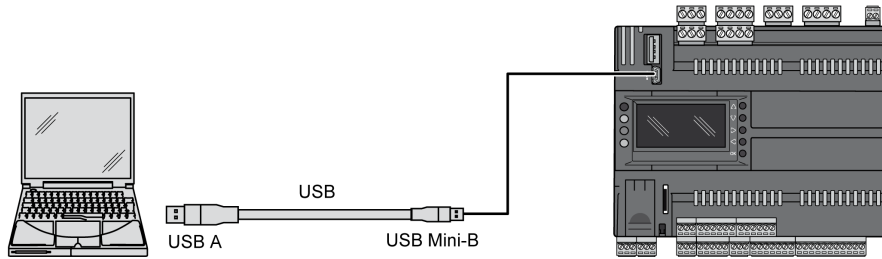

To connect the PC to the controller, use a type A / type Mini-B USB cable.

Following operations are possible between the PC and the controller in direct USB connection:

Data type	PC → Controller	Controller →PC
Parameters	✓	✓
Controller application	✓	✓
HMI application	✓	✓
Data file	✓	✓
BIOS	✓	-

### Connecting The PC to The Remote Display

Direct connection between the PC and the remote display:

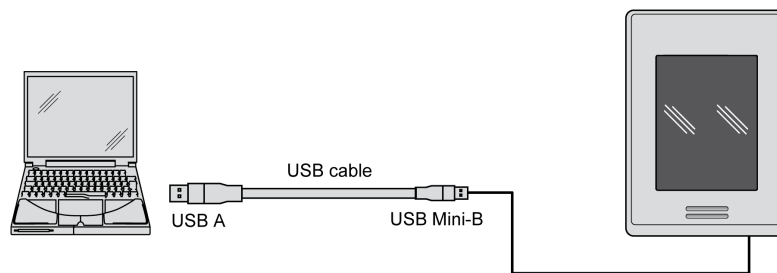

To connect the PC to the remote display, use a type A / type micro-B USB cable.

Following operations are possible between the PC and the controller in direct USB connection:

Data type	PC → Remote display	Remote display →PC
Parameters	✓	✓
Controller application	✓	-
HMI application	✓	-
Data file	-	-
BIOS	✓	-

## Connection with a USB Memory Key

### Connecting a USB Memory Key to The Controller

Connection of the USB memory key to the TM172P..... controller:

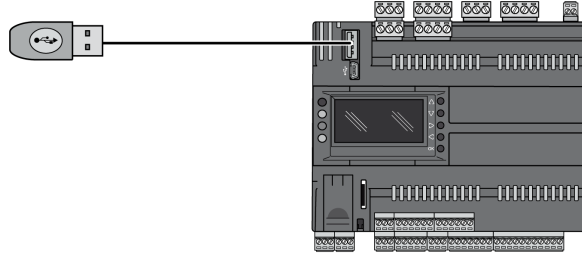

The USB memory key is connected on the type A USB port of the controller.

Following operations are possible between the USB memory key and the controller in direct USB connection:

Data type	Memory key → Controller	Controller → Memory key
Parameters	✓	✓
Controller application	✓	✓
HMI application	✓	✓
Data file	✓	✓
BIOS	-	-

## Connection with a PC Through Ethernet

### Connecting The PC to The Controller

Direct connection between the PC and the TM172P..... controller:

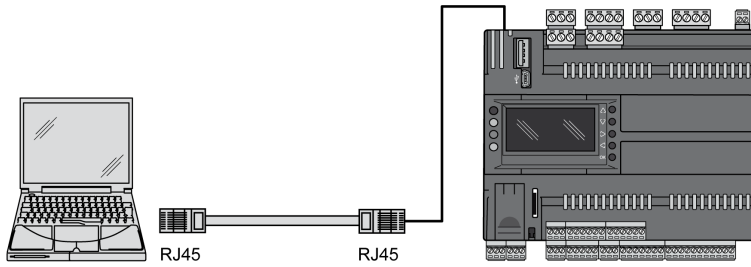

To connect the PC to the controller, use a RJ45 Ethernet cable.

Following operations are possible between the PC and the controller in direct Ethernet connection:

Data type	PC → Controller	Controller → PC
Parameters	✓	✓
Controller application	✓	✓
HMI application	✓	✓
Data file	✓	✓
BIOS	✓	-

### Connecting The PC to The Remote Display

Connection between the PC and the remote display through the controller:

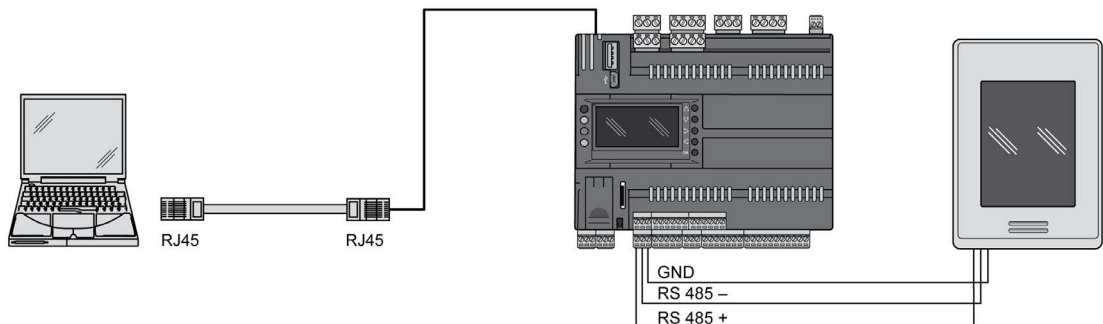

To connect the PC to the remote display through the controller, use:

- A RJ45 Ethernet cable between the PC and the controller.
- An RS-485 connection between the controller and the remote display

**NOTE:** Bridge function must be enabled in the TM172P..... / TM172O..... controller, TM172DCL..... run as Slave Modbus/RTU.

Following operations are possible between the PC and the remote display connected through the controller:

Data type	PC → Remote display	Remote display → PC
Parameters	✓	✓
Controller application	✓	-
HMI application	✓	-
Data file	-	-
BIOS	✓	-



---

# Chapter 16

## BIOS Update

---

### Controller Update BIOS

#### Overview

There are several ways to update the M172 Performance, M172 Expansion and M172 Display Color Touchscreen BIOS:

- Downloading into the Modicon M172 Logic Controller from USB memory key
- Downloading into the Modicon M172 Logic Controller from PC with EcoStruxure Machine Expert - HVAC
- downloading into the Modicon M172 Expansion Module from PC with EcoStruxure Machine Expert - HVAC
- downloading into the Modicon M172 Display Color Touchscreen from PC with EcoStruxure Machine Expert - HVAC

#### Download BIOS from USB Memory Key

Steps to download BIOS from USB memory key:

Step	Action
1	Trace the BIOS file (it has the file extension .bin) in one of the following ways alternatively: <ul style="list-style-type: none"><li>• If you have EcoStruxure Machine Expert - HVAC installed on your PC, BIOS is available in the following: &lt;C:\Programs&gt;\Schneider Electric\EcoStruxureHVAC\Catalog\FreeAdvance&lt;firmware&gt; Where &lt;firmware&gt; = firmwarexxx</li><li>• Download .bin file from website - Firmware Update section.</li></ul>
2	Copy this file into a USB memory key (for example, mskxxx_yy.bin)
3	Connect USB memory key to Modicon M172 Logic Controller. <ul style="list-style-type: none"><li>• BIOS is downloaded into Modicon M172 Logic Controller: yellow LED flashes during download.</li><li>• When the download is completed, green LED flashes twice and switch ON to confirm successful download.</li></ul>
4	Remove USB memory key. <ul style="list-style-type: none"><li>• Modicon M172 Logic Controller automatically resets and restarts.</li><li>• If a SYSTEM FAULT message appears, it is related to a watchdog time-out that occurred while updating the BIOS and, in this case, can be ignored</li></ul> BIOS update has been completed successfully.

Modicon M172 Logic Controller does not download a non-compliant BIOS (for example you cannot download BIOS for Modicon M171 Optimized Logic Controller into an Modicon M172 Logic Controller and vice versa).

#### Download BIOS from PC

Steps to download BIOS from PC:

Step	Action
1	Connect the Modicon M172 Logic Controller, Modicon M172 Expansion Module, or Modicon M172 Display Color Touchscreen via USB or RS 485 to the PC.
2	Open EcoStruxure Machine Expert - HVAC software.
3	Add, for instance, an Modicon M172 Logic Controller target to the project. <ul style="list-style-type: none"><li>• Select the correct target device.</li><li>• The BIOS files links are: &lt;C:\Programs&gt;\Schneider Electric\EcoStruxureHVAC\Catalog\FreeAdvance&lt;firmware&gt; Where &lt;firmware&gt; = firmwarexxx</li></ul>
4	Select the name of the target and right-click it.
5	Select BIOS download.
6	Open the .bin file you want to download.

Step	Action
7	Click Download button. The operation may take a few minutes. If the download terminates successfully, a confirmation is displayed.
8	Disconnect the Modicon M172 Logic Controller from the PC.

---

# Appendices

---





---

# Appendix A

## Appendices

---

### What Is in This Chapter?

This chapter contains the following topics:

Topic	Page
NTC 10k beta 3435 Resistance Temperature Table	174
NTC 10k-2 beta (25/50) 3977 Resistance Temperature Table	176
Pt1000 Resistance Temperature Table	178

## NTC 10k beta 3435 Resistance Temperature Table

### Celsius

T (°C)	R (Ω)	T (°C)	R (Ω)	T (°C)	R (Ω)	T (°C)	R (Ω)	T (°C)	R (Ω)	T (°C)	R (Ω)
-40	187 400	-13	48 590	14	15 270	41	5 630	68	2 366	95	1 108
-39	177 500	-12	46 410	15	14 680	42	5 440	69	2 296	96	1 080
-38	168 200	-11	44 350	16	14 110	43	5 257	70	2 229	97	1 052
-37	159 400	-10	42 390	17	13 570	44	5 081	71	2 164	98	1 025
-36	151 100	-9	40 500	18	13 050	45	4 912	72	2 101	99	999.0
-35	143 400	-8	38 700	19	12 560	46	4 750	73	2 040	100	973.7
-34	136 100	-7	37 000	20	12 090	47	4 594	74	1 981	101	949.0
-33	129 200	-6	35 380	21	11 630	48	4 444	75	1 925	102	925.0
-32	122 800	-5	33 850	22	11 200	49	4 300	76	1 870	103	901.8
-31	116 700	-4	32 390	23	10 780	50	4 162	77	1 817	104	879.3
-30	110 900	-3	31 000	24	10 380	51	4 027	78	1 766	105	857.4
-29	105 400	-2	29 690	25	10 000	52	3 897	79	1 716	106	836.3
-28	100 100	-1	28 440	26	9 633	53	3 773	80	1 669	107	815.7
-27	95 220	0	27 250	27	9 281	54	3 653	81	1 622	108	795.8
-26	90 570	1	26 100	28	8 945	55	3 537	82	1 577	109	776.4
-25	86 180	2	25 000	29	8 623	56	3 426	83	1 534	110	757.6
-24	82 040	3	23 960	30	8 314	57	3 319	84	1 492	111	739.2
-23	78 130	4	22 970	31	8 016	58	3 216	85	1 451	112	721.4
-22	74 440	5	22 030	32	7 730	59	3 117	86	1 412	113	704.1
-21	70 940	6	21 130	33	7 456	60	3 022	87	1 374	114	687.3
-20	67 640	7	20 280	34	7 193	61	2 929	88	1 337	115	671.0
-19	64 440	8	19 460	35	6 941	62	2 839	89	1 301	116	655.2
-18	61 420	9	18 690	36	6 700	63	2 753	90	1 266	117	639.8
-17	58 570	10	17 950	37	6 468	64	2 670	91	1 233	118	624.8
-16	55 870	11	17 230	38	6 246	65	2 589	92	1 200	119	610.3
-15	53 310	12	16 550	39	6 033	66	2 512	93	1 169	120	596.1
-14	50 880	13	15 900	40	5 829	67	2 438	94	1 138		

Fahrenheit

T (°F)	R (Ω)	T (°F)	R (Ω)	T (°F)	R (Ω)	T (°F)	R (Ω)	T (°F)	R (Ω)	T (°F)	R (Ω)
-40.0	187 400	8.6	48 590	57.2	15 270	105.8	5 630	154.4	2 366	203.0	1 108
-38.2	177 500	10.4	46 410	59.0	14 680	107.6	5 440	156.2	2 296	204.8	1 080
-36.4	168 200	12.2	44 350	60.8	14 110	109.4	5 257	158.0	2 229	206.6	1 052
-34.6	159 400	14.0	42 390	62.6	13 570	111.2	5 081	159.8	2 164	208.4	1 025
-32.8	151 100	15.8	40 500	64.4	13 050	113.0	4 912	161.6	2 101	210.2	999.0
-31.0	143 400	17.6	38 700	66.2	12 560	114.8	4 750	163.4	2 040	212.0	973.7
-29.2	136 100	19.4	37 000	68.0	12 090	116.6	4 594	165.2	1 981	213.8	949.0
-27.4	129 200	21.2	35 380	69.8	11 630	118.4	4 444	167.0	1 925	215.6	925.0
-25.6	122 800	23.0	33 850	71.6	11 200	120.2	4 300	168.8	1 870	217.4	901.8
-23.8	116 700	24.8	32 390	73.4	10 780	122.0	4 162	170.6	1 817	219.2	879.3
-22.0	110 900	26.6	31 000	75.2	10 380	123.8	4 027	172.4	1 766	221.0	857.4
-20.2	105 400	28.4	29 690	77.0	10 000	125.6	3 897	174.2	1 716	222.8	836.3
-18.4	100 100	30.2	28 440	78.8	9 633	127.4	3 773	176.0	1 669	224.6	815.7
-16.6	95 220	32.0	27 250	80.6	9 281	129.2	3 653	177.8	1 622	226.4	795.8
-14.8	90 570	33.8	26 100	82.4	8 945	131.0	3 537	179.6	1 577	228.2	776.4
-13.0	86 180	35.6	25 000	84.2	8 623	132.8	3 426	181.4	1 534	230.0	757.6
-11.2	82 040	37.4	23 960	86.0	8 314	134.6	3 319	183.2	1 492	231.8	739.2
-9.4	78 130	39.2	22 970	87.8	8 016	136.4	3 216	185.0	1 451	233.6	721.4
-7.6	74 440	41.0	22 030	89.6	7 730	138.2	3 117	186.8	1 412	235.4	704.1
-5.8	70 940	42.8	21 130	91.4	7 456	140.0	3 022	188.6	1 374	237.2	687.3
-4.0	67 640	44.6	20 280	93.2	7 193	141.8	2 929	190.4	1 337	239.0	671.0
-2.2	64 440	46.4	19 460	95.0	6 941	143.6	2 839	192.2	1 301	240.8	655.2
-0.4	61 420	48.2	18 690	96.8	6 700	145.4	2 753	194.0	1 266	242.6	639.8
1.4	58 570	50.0	17 950	98.6	6 468	147.2	2 670	195.8	1 233	244.4	624.8
3.2	55 870	51.8	17 230	100.4	6 246	149.0	2 589	197.6	1 200	246.2	610.3
5.0	53 310	53.6	16 550	102.2	6 033	150.8	2 512	199.4	1 169	248.0	596.1
6.8	50 880	55.4	15 900	104.0	5 829	152.6	2 438	201.2	1 138		

**NTC 10k-2 beta (25/50) 3977 Resistance Temperature Table**

**Celsius**

T (°C)	R (Ω)	T (°C)	R (Ω)	T (°C)	R (Ω)	T (°C)	R (Ω)	T (°C)	R (Ω)
-39.44	323 839	13.89	68 518	11.67	18 378	37.22	5 960	62.78	2 252
-38.33	300 974	12.78	64 419	12.78	17 437	38.33	5 697	63.89	2 165
-37.22	279 880	11.67	60 592	13.89	16 550	39.44	5 447	65.00	2 082
-36.11	260 410	10.56	57 017	15.00	15 714	40.56	5 207	66.11	2 003
-35.00	242 427	9.44	53 647	16.11	14 925	41.67	4 981	67.22	1 927
-33.89	225 809	8.33	50 526	17.22	14 180	42.78	4 766	68.33	1 855
-32.78	210 443	7.22	47 606	18.33	13 478	43.89	4 561	69.44	1 785
-31.67	196 227	6.11	44 874	19.44	12 814	45.00	4 367	70.56	1 718
-30.56	183 068	5.00	42 317	20.56	12 182	46.11	4 182	71.67	1 655
-29.44	170 775	3.89	39 921	21.67	11 590	47.22	4 006	72.78	1 594
-28.33	159 488	2.78	37 676	22.78	11 030	48.33	3 838	73.89	1 536
-27.22	149 024	1.67	35 573	23.89	10 501	49.44	3 679	75.00	1 480
-26.11	139 316	0.56	33 599	25.00	10 000	50.56	3 525	76.11	1 427
-25.00	130 306	0.56	31 732	26.11	9 526	51.67	3 380	77.22	1 375
-23.89	121 939	1.67	29 996	27.22	9 078	52.78	3 242	78.33	1 326
-22.78	114 165	2.78	28 365	28.33	8 653	53.89	3 111	79.44	1 279
-21.67	106 939	3.89	26 834	29.44	8 251	55.00	2 985	80.56	1 234
-20.56	100 218	5.00	25 395	30.56	7 866	56.11	2 865	81.67	1 190
-19.44	93 909	6.11	24 042	31.67	7 505	57.22	2 751	82.78	1 149
-18.33	88 090	7.22	22 770	32.78	7 163	58.33	2 642	83.89	1 109
-17.22	82 670	8.33	21 573	33.89	6 838	59.44	2 538	85.00	1 070
-16.11	77 620	9.44	20 446	35.00	6 530	60.56	2 438	86.11	1 034
-15.00	72 911	10.56	19 376	36.11	6 238	61.67	2 343		



Fahrenheit

T (°F)	R (Ω)	T (°F)	R (Ω)	T (°F)	R (Ω)	T (°F)	R (Ω)	T (°F)	R (Ω)
-39	323 839	57	68 518	53	18 378	99	5 960	145	2 252
-37	300 974	55	64 419	55	17 437	101	5 697	147	2 165
-35	279 880	53	60 592	57	16 550	103	5 447	149	2 082
-33	260 410	51	57 017	59	15 714	105	5 207	151	2 003
-31	242 427	49	53 647	61	14 925	107	4 981	153	1 927
-29	225 809	47	50 526	63	14 180	109	4 766	155	1 855
-27	210 443	45	47 606	65	13 478	111	4 561	157	1 785
-25	196 227	43	44 874	67	12 814	113	4 367	159	1 718
-23	183 068	41	42 317	69	12 182	115	4 182	161	1 655
-21	170 775	39	39 921	71	11 590	117	4 006	163	1 594
-19	159 488	37	37 676	73	11 030	119	3 838	165	1 536
-17	149 024	35	35 573	75	10 501	121	3 679	167	1 480
-15	139 316	33	33 599	77	10 000	123	3 525	169	1 427
-13	130 306	33	31 732	79	9 526	125	3 380	171	1 375
-11	121 939	35	29 996	81	9 078	127	3 242	173	1 326
-9	114 165	37	28 365	83	8 653	129	3 111	175	1 279
-7	106 939	39	26 834	85	8 251	131	2 985	177	1 234
-5	100 218	41	25 395	87	7 866	133	2 865	179	1 190
-3	93 909	43	24 042	89	7 505	135	2 751	181	1 149
-1	88 090	45	22 770	91	7 163	137	2 642	183	1 109
1	82 670	47	21 573	93	6 838	139	2 538	185	1 070
3	77 620	49	20 446	95	6 530	141	2 438	187	1 034
5	72 911	51	19 376	97	6 238	143	2 343		

## Pt1000 Resistance Temperature Table

### Celsius

T (°C)	R (Ω)	T (°C)	R (Ω)	T (°C)	R (Ω)	T (°C)	R (Ω)	T (°C)	R (Ω)	T (°C)	R (Ω)
-100	602.56	-73	711.34	-46	818.94	-19	925.53	8	1 031.23	35	1 136.08
-99	606.61	-72	715.34	-45	822.90	-18	929.46	9	1 035.13	36	1 139.95
-98	610.66	-71	719.34	-44	826.87	-17	933.39	10	1 039.03	37	1 143.82
-97	614.71	-70	723.35	-43	830.83	-16	937.32	11	1 042.92	38	1 147.68
-96	618.76	-69	727.35	-42	834.79	-15	941.24	12	1 046.82	39	1 151.55
-95	622.80	-68	731.34	-41	838.75	-14	945.17	13	1 050.71	40	1 155.41
-94	626.84	-67	735.34	-40	842.71	-13	949.09	14	1 054.60	41	1 159.27
-93	630.88	-66	739.34	-39	846.66	-12	953.02	15	1 058.49	42	1 163.13
-92	634.92	-65	743.33	-38	850.62	-11	956.94	16	1 062.38	43	1 166.99
-91	638.96	-64	747.32	-37	854.57	-10	960.86	17	1 066.27	44	1 170.85
-90	643.00	-63	751.31	-36	858.53	-9	964.78	18	1 070.16	45	1 174.70
-89	647.03	-62	755.30	-35	862.48	-8	968.70	19	1 074.05	46	1 178.56
-88	651.06	-61	759.29	-34	866.43	-7	972.61	20	1 077.94	47	1 182.41
-87	655.09	-60	763.28	-33	870.38	-6	976.53	21	1 081.82	48	1 186.27
-86	659.12	-59	767.26	-32	874.32	-5	980.44	22	1 085.70	49	1 190.12
-85	663.15	-58	771.25	-31	878.27	-4	984.36	23	1 089.59	50	1 193.97
-84	667.17	-57	775.23	-30	882.22	-3	988.27	24	1 093.47	51	1 197.82
-83	671.20	-56	779.21	-29	886.16	-2	992.18	25	1 097.35	52	1 201.67
-82	675.22	-55	783.19	-28	890.10	-1	996.09	26	1 101.23	53	1 205.52
-81	679.24	-54	787.17	-27	894.04	0	1 000.00	27	1 105.10	54	1 209.36
-80	683.25	-53	791.14	-26	897.98	1	1 003.91	28	1 108.98	55	1 213.21
-79	687.27	-52	795.12	-25	901.92	2	1 007.81	29	1 112.86	56	1 217.05
-78	691.29	-51	799.09	-24	905.86	3	1 011.72	30	1 116.73	57	1 220.90
-77	695.30	-50	803.06	-23	909.80	4	1 015.62	31	1 120.60	58	1 224.74
-76	699.31	-49	807.03	-22	913.73	5	1 019.53	32	1 124.47	59	1 228.58
-75	703.32	-48	811.00	-21	917.67	6	1 023.43	33	1 128.35	60	1 232.42
-74	707.33	-47	814.97	-20	921.60	7	1 027.33	34	1 132.21	61	1 236.26

T (°C)	R (Ω)	T (°C)	R (Ω)	T (°C)	R (Ω)	T (°C)	R (Ω)	T (°C)	R (Ω)	T (°C)	R (Ω)
62	1 240.09	86	1 331.84	110	1 422.93	134	1 513.34	158	1 603.09	182	1 692.18
63	1 243.93	87	1 335.65	111	1 426.71	135	1 517.10	159	1 606.82	183	1 695.88
64	1 247.77	88	1 339.46	112	1 430.49	136	1 520.85	160	1 610.54	184	1 699.58
65	1 251.60	89	1 343.26	113	1 434.26	137	1 524.60	161	1 614.27	185	1 703.27
66	1 255.43	90	1 347.07	114	1 438.04	138	1 528.35	162	1 617.99	186	1 706.96
67	1 259.26	91	1 350.87	115	1 441.82	139	1 532.10	163	1 621.71	187	1 710.66
68	1 263.09	92	1 354.68	116	1 445.59	140	1 535.84	164	1 625.43	188	1 714.35
69	1 266.92	93	1 358.48	117	1 449.37	141	1 539.59	165	1 629.15	189	1 718.04
70	1 270.75	94	1 362.28	118	1 453.14	142	1 543.33	166	1 632.86	190	1 721.73
71	1 274.58	95	1 366.08	119	1 456.91	143	1 547.08	167	1 636.58	191	1 725.42
72	1 278.40	96	1 369.87	120	1 460.68	144	1 550.82	168	1 640.30	192	1 729.10
73	1 282.23	97	1 373.67	121	1 464.45	145	1 554.56	169	1 644.01	193	1 732.79
74	1 286.05	98	1 377.47	122	1 468.22	146	1 558.30	170	1 647.72	194	1 736.48
75	1 289.87	99	1 381.26	123	1 471.98	147	1 562.04	171	1 651.43	195	1 740.16
76	1 293.70	100	1 385.06	124	1 475.75	148	1 565.78	172	1 655.14	196	1 743.84
77	1 297.52	101	1 388.85	125	1 479.51	149	1 569.52	173	1 658.85	197	1 747.52
78	1 301.33	102	1 392.64	126	1 483.28	150	1 573.25	174	1 662.56	198	1 751.20
79	1 305.15	103	1 396.43	127	1 487.04	151	1 576.99	175	1 666.27	199	1 754.88
80	1 308.97	104	1 400.22	128	1 490.80	152	1 580.72	176	1 669.97	200	1 758.56
81	1 312.78	105	1 404.00	129	1 494.56	153	1 584.45	177	1 673.68		
82	1 316.60	106	1 407.79	130	1 498.32	154	1 588.18	178	1 677.38		
83	1 320.41	107	1 411.58	131	1 502.08	155	1 591.91	179	1 681.08		
84	1 324.22	108	1 415.36	132	1 505.83	156	1 595.64	180	1 684.78		
85	1 328.03	109	1 419.14	133	1 509.59	157	1 599.37	181	1 688.48		

Fahrenheit

T (°F)	R (Ω)	T (°F)	R (Ω)	T (°F)	R (Ω)	T (°F)	R (Ω)	T (°F)	R (Ω)	T (°F)	R (Ω)
-148.0	602.56	-99.4	711.34	-50.8	818.94	-2.2	925.53	46.4	1 031.23	95.0	1 136.08
-146.2	606.61	-97.6	715.34	-49.0	822.90	-0.4	929.46	48.2	1 035.13	96.8	1 139.95
-144.4	610.66	-95.8	719.34	-47.2	826.87	1.4	933.39	50.0	1 039.03	98.6	1 143.82
-142.6	614.71	-94.0	723.35	-45.4	830.83	3.2	937.32	51.8	1 042.92	100.4	1 147.68
-140.8	618.76	-92.2	727.35	-43.6	834.79	5.0	941.24	53.6	1 046.82	102.2	1 151.55
-139.0	622.80	-90.4	731.34	-41.8	838.75	6.8	945.17	55.4	1 050.71	104.0	1 155.41
-137.2	626.84	-88.6	735.34	-40.0	842.71	8.6	949.09	57.2	1 054.60	105.8	1 159.27
-135.4	630.88	-86.8	739.34	-38.2	846.66	10.4	953.02	59.0	1 058.49	107.6	1 163.13
-133.6	634.92	-85.0	743.33	-36.4	850.62	12.2	956.94	60.8	1 062.38	109.4	1 166.99
-131.8	638.96	-83.2	747.32	-34.6	854.57	14.0	960.86	62.6	1 066.27	111.2	1 170.85
-130.0	643.00	-81.4	751.31	-32.8	858.53	15.8	964.78	64.4	1 070.16	113.0	1 174.70
-128.2	647.03	-79.6	755.30	-31.0	862.48	17.6	968.70	66.2	1 074.05	114.8	1 178.56
-126.4	651.06	-77.8	759.29	-29.2	866.43	19.4	972.61	68.0	1 077.94	116.6	1 182.41
-124.6	655.09	-76.0	763.28	-27.4	870.38	21.2	976.53	69.8	1 081.82	118.4	1 186.27
-122.8	659.12	-74.2	767.26	-25.6	874.32	23.0	980.44	71.6	1 085.70	120.2	1 190.12
-121.0	663.15	-72.4	771.25	-23.8	878.27	24.8	984.36	73.4	1 089.59	122.0	1 193.97
-119.2	667.17	-70.6	775.23	-22.0	882.22	26.6	988.27	75.2	1 093.47	123.8	1 197.82
-117.4	671.20	-68.8	779.21	-20.2	886.16	28.4	992.18	77.0	1 097.35	125.6	1 201.67
-115.6	675.22	-67.0	783.19	-18.4	890.10	30.2	996.09	78.8	1 101.23	127.4	1 205.52
-113.8	679.24	-65.2	787.17	-16.6	894.04	32.0	1 000.00	80.6	1 105.10	129.2	1 209.36
-112.0	683.25	-63.4	791.14	-14.8	897.98	33.8	1 003.91	82.4	1 108.98	131.0	1 213.21
-110.2	687.27	-61.6	795.12	-13.0	901.92	35.6	1 007.81	84.2	1 112.86	132.8	1 217.05
-108.4	691.29	-59.8	799.09	-11.2	905.86	37.4	1 011.72	86.0	1 116.73	134.6	1 220.90
-106.6	695.30	-58.0	803.06	-9.4	909.80	39.2	1 015.62	87.8	1 120.60	136.4	1 224.74
-104.8	699.31	-56.2	807.03	-7.6	913.73	41.0	1 019.53	89.6	1 124.47	138.2	1 228.58
-103.0	703.32	-54.4	811.00	-5.8	917.67	42.8	1 023.43	91.4	1 128.35	140.0	1 232.42
-101.2	707.33	-52.6	814.97	-4.0	921.60	44.6	1 027.33	93.2	1 132.21	141.8	1 236.26

T (°F)	R (Ω)	T (°F)	R (Ω)	T (°F)	R (Ω)	T (°F)	R (Ω)	T (°F)	R (Ω)	T (°F)	R (Ω)
143.6	1 240.09	186.8	1 331.84	230.0	1 422.93	273.2	1 513.34	316.4	1 603.09	359.6	1 692.18
145.4	1 243.93	188.6	1 335.65	231.8	1 426.71	275.0	1 517.10	318.2	1 606.82	361.4	1 695.88
147.2	1 247.77	190.4	1 339.46	233.6	1 430.49	276.8	1 520.85	320.0	1 610.54	363.2	1 699.58
149.0	1 251.60	192.2	1 343.26	235.4	1 434.26	278.6	1 524.60	321.8	1 614.27	365.0	1 703.27
150.8	1 255.43	194.0	1 347.07	237.2	1 438.04	280.4	1 528.35	323.6	1 617.99	366.8	1 706.96
152.6	1 259.26	195.8	1 350.87	239.0	1 441.82	282.2	1 532.10	325.4	1 621.71	368.6	1 710.66
154.4	1 263.09	197.6	1 354.68	240.8	1 445.59	284.0	1 535.84	327.2	1 625.43	370.4	1 714.35
156.2	1 266.92	199.4	1 358.48	242.6	1 449.37	285.8	1 539.59	329.0	1 629.15	372.2	1 718.04
158.0	1 270.75	201.2	1 362.28	244.4	1 453.14	287.6	1 543.33	330.8	1 632.86	374.0	1 721.73
159.8	1 274.58	203.0	1 366.08	246.2	1 456.91	289.4	1 547.08	332.6	1 636.58	375.8	1 725.42
161.6	1 278.40	204.8	1 369.87	248.0	1 460.68	291.2	1 550.82	334.4	1 640.30	377.6	1 729.10
163.4	1 282.23	206.6	1 373.67	249.8	1 464.45	293.0	1 554.56	336.2	1 644.01	379.4	1 732.79
165.2	1 286.05	208.4	1 377.47	251.6	1 468.22	294.8	1 558.30	338.0	1 647.72	381.2	1 736.48
167.0	1 289.87	210.2	1 381.26	253.4	1 471.98	296.6	1 562.04	339.8	1 651.43	383.0	1 740.16
168.8	1 293.70	212.0	1 385.06	255.2	1 475.75	298.4	1 565.78	341.6	1 655.14	384.8	1 743.84
170.6	1 297.52	213.8	1 388.85	257.0	1 479.51	300.2	1 569.52	343.4	1 658.85	386.6	1 747.52
172.4	1 301.33	215.6	1 392.64	258.8	1 483.28	302.0	1 573.25	345.2	1 662.56	388.4	1 751.20
174.2	1 305.15	217.4	1 396.43	260.6	1 487.04	303.8	1 576.99	347.0	1 666.27	390.2	1 754.88
176.0	1 308.97	219.2	1 400.22	262.4	1 490.80	305.6	1 580.72	348.8	1 669.97	392.0	1 758.56
177.8	1 312.78	221.0	1 404.00	264.2	1 494.56	307.4	1 584.45	350.6	1 673.68		
179.6	1 316.60	222.8	1 407.79	266.0	1 498.32	309.2	1 588.18	352.4	1 677.38		
181.4	1 320.41	224.6	1 411.58	267.8	1 502.08	311.0	1 591.91	354.2	1 681.08		
183.2	1 324.22	226.4	1 415.36	269.6	1 505.83	312.8	1 595.64	356.0	1 684.78		
185.0	1 328.03	228.2	1 419.14	271.4	1 509.59	314.6	1 599.37	357.8	1 688.48		





## A

### analog input

Converts received voltage or current levels into numerical values. You can store and process these values within the logic controller.

### analog output

Converts numerical values within the logic controller and sends out proportional voltage or current levels.

### application

A program including configuration data, symbols, and documentation.

### AWG

(*American wire gauge*) The standard that specifies wire section sizes in North America.

## B

### BIOS

(*basic input output system*) Part of the firmware used during the booting process.

### BOOL

(*boolean*) A basic data type in computing. A `BOOL` variable can have one of these values: 0 (`FALSE`), 1 (`TRUE`). A bit that is extracted from a word is of type `BOOL`.

## C

### controller

Automates industrial processes (also known as programmable logic controller or programmable controller).

### CSA

(*Canadian standards association*) The Canadian standard for industrial electronic equipment in hazardous environments.

## D

### digital I/O

(*digital input/output*) An individual circuit connection at the electronic module that corresponds directly to a data table bit. The data table bit holds the value of the signal at the I/O circuit. It gives the control logic digital access to I/O values.

## E

### EEPROM

(*electrically erasable programmable read-only memory*) A type of non-volatile memory to store required data even when power is removed.

### EIA

(*electronic industries alliance*) The trade organization for establishing electrical/electronic and data communication standards (including RS-232 and RS-485) in the United States.

### EMC

(*electromagnetic compatibility*)

### EN

EN identifies one of many European standards maintained by CEN (*European Committee for Standardization*), CENELEC (*European Committee for Electrotechnical Standardization*), or ETSI (*European Telecommunications Standards Institute*).

### expansion bus

An electronic communication bus between expansion I/O modules and a controller.

**F****firmware**

Represents the BIOS, data parameters, and programming instructions that constitute the operating system on a controller. The firmware is stored in non-volatile memory within the controller.

**FLA**

*(Full-Load Amperes)* Amount of current drawn by the motor at rated load and rated voltage.

**flash memory**

A non-volatile memory that can be overwritten. It is stored on a special EEPROM that can be erased and reprogrammed.

**H****HVAC&R**

*(heating, ventilation, and air conditioning and refrigeration)*

**I****I/O**

*(input/output)*

**ID**

*(identifier/identification)*

**IEC 61131-3**

Part 3 of a 3-part IEC standard for industrial automation equipment. IEC 61131-3 is concerned with controller programming languages and defines 2 graphical and 2 textual programming language standards. The graphical programming languages are ladder diagram and function block diagram. The textual programming languages include structured text and instruction list.

**IP20**

*(ingress protection)* The protection classification according to IEC 60529 offered by an enclosure, shown by the letter IP and 2 digits. The first digit indicates 2 factors: helping protect persons and for equipment. The second digit indicates helping protect against water. IP20 devices help protect against electric contact of objects larger than 12.5 mm, but not against water.

**L****LAN**

*(local area network)* A short-distance communications network that is implemented in a home, office, or institutional environment.

**LCD**

*(liquid crystal display)* Used in many HMI devices to display menus and messages to machine operators.

**LED**

*(light emitting diode)* An indicator that illuminates under a low-level electrical charge.

**LRA**

*(Locked-Rotor Amperes)* Amount of current drawn by the motor at rated voltage while its rotor is locked. This provides an indication of the inrush current during start-up.

**M****Modbus**

The protocol that allows communications between many devices connected to the same network.

**Modbus SL**

*(Modbus serial line)* Implementation of the protocol over a RS-232 or RS-485 serial connection.

**ms**

*(millisecond)*



**N****NC**

(*normally closed*) A contact pair that closes when the actuator is de-energized (no power is applied) and opens when the actuator is energized (power is applied).

**network**

A system of interconnected devices that share a common data path and protocol for communications.

**NO**

(*normally open*) A contact pair that opens when the actuator is de-energized (no power is applied) and closes when the actuator is energized (power is applied).

**NTC**

(*Negative Temperature Coefficient*)

**P****PLC**

(*programmable logic controller*) An industrial computer used to automate manufacturing, industrial, and other electromechanical processes. PLCs are different from common computers in that they are designed to have multiple input and output arrays and adhere to more robust specifications for shock, vibration, temperature, and electrical interference among other things.

**power supply terminals**

The power supply is connected to these terminals to provide power to the controller.

**protocol**

A convention or standard definition that controls or enables the connection, communication, and data transfer between 2 computing system and devices.

**Pt100/Pt1000**

(*platinum 100/1000*) Resistance thermometers, also referred to as resistance temperature detectors, are sensors used to measure temperature by correlating electrical resistance with temperature. As the temperature changes, the resistance to an electrical current passing through them predictably changes likewise. They are characterized by their nominal resistance  $R_0$  at a temperature of 0 °C.

- Pt100 ( $R_0 = 100 \Omega$ )
- Pt1000 ( $R_0 = 1 \text{ k}\Omega$ )

**PWM**

(*pulse width modulation*) A fast output that oscillates between off and on in an adjustable duty cycle, producing a rectangular wave form (though you can adjust it to produce a square wave). The PWM is well adapted to simulate or approximate an analog output in that it regulates the voltage of the output over its period making it useful in light dimming or speed control applications, among others.

**R****RS-485**

A standard type of serial communication bus, based on 2 wires (also known as EIA RS-485).

**RTC**

(*real-time clock*) A battery-backed time-of-day and calendar clock that operates continuously, even when the controller is not powered for the life of the battery.

**S****SELV**

(*safety extra low voltage*) A system that follows IEC 61140 guidelines for power supplies is protected in such a way that voltage between any 2 accessible parts (or between 1 accessible part and the PE terminal for class 1 equipment) does not exceed a specified value under normal conditions or under inoperable conditions.

**sink input**

A wiring arrangement in which the device provides current to the input electronic module. A sink input is referenced to 0 Vdc.

**SL**

(*serial line*)

**SPDT**

*(single-pole, double-throw)*

**SPST**

*(single-pole, single-throw)*

**SSR**

*(solid-state relay)*

## T

**terminal block**

*(terminal block)* The component that mounts in an electronic module and provides electrical connections between the controller and the field devices.

## U

**UL**

*(underwriters laboratories)* A US organization for product testing and safety certification.

## W

**WORD**

A type encoded in a 16-bit format.



## C

CAN expansion bus, *104*  
Communication, *103*

## P

Power Supply, *73*

## R

RTC, *115*

## S

Specifications  
    Controller and Expansion Modules, *51*  
    Displays, *121*

## T

TM172DCLF•, *125*  
TM172DCLWT••, *124*  
TM172E12R, *66*  
TM172E28R, *68*  
TM172P••18• / TM172O••18•, *56*  
TM172P••28•• / TM172O••28R, *59*  
TM172P••42•• / TM172O••42R, *62*  
TM172P•G07R, *54*

