

Modicon M171

Electronic Expansion Valve drivers

User Guide

10/2018



The information provided in this documentation contains general descriptions and/or technical characteristics of the performance of the products contained herein. This documentation is not intended as a substitute for and is not to be used for determining suitability or reliability of these products for specific user applications. It is the duty of any such user or integrator to perform the appropriate and complete risk analysis, evaluation and testing of the products with respect to the relevant specific application or use thereof. Neither Schneider Electric nor any of its affiliates or subsidiaries shall be responsible or liable for misuse of the information contained herein. If you have any suggestions for improvements or amendments or have found errors in this publication, please notify us.

You agree not to reproduce, other than for your own personal, noncommercial use, all or part of this document on any medium whatsoever without permission of Schneider Electric, given in writing. You also agree not to establish any hypertext links to this document or its content. Schneider Electric does not grant any right or license for the personal and noncommercial use of the document or its content, except for a non-exclusive license to consult it on an “as is” basis, at your own risk. All other rights are reserved.

All pertinent state, regional, and local safety regulations must be observed when installing and using this product. For reasons of safety and to help ensure compliance with documented system data, only the manufacturer should perform repairs to components.

When devices are used for applications with technical safety requirements, the relevant instructions must be followed.

Failure to use Schneider Electric software or approved software with our hardware products may result in injury, harm, or improper operating results.

Failure to observe this information can result in injury or equipment damage.

© 2018 Schneider Electric - All Rights Reserved.

TABLE OF CONTENTS



	SAFETY INFORMATION	6
	ABOUT THE BOOK	8
CHAPTER	1. RANGE OVERVIEW.....	10
	INTRODUCTION	10
	RANGE	11
	ACCESSORIES.....	12
	CONTENTS OF PACK.....	12
CHAPTER	2. MECHANICAL INSTALLATION	13
	BEFORE STARTING	13
	TM171VEV•• INSTALLATION.....	15
	ACCESS TO DIP-SWITCHES.....	18
CHAPTER	3. ELECTRICAL CONNECTIONS.....	19
	WIRING BEST PRACTICES.....	19
	WIRING DIAGRAMS	24
	TM171VEV•• - TM171DLED CONNECTION.....	30
	VALVE CONNECTION.....	31
CHAPTER	4. ENVIRONMENTAL CHARACTERISTICS.....	32
	GENERAL SPECIFICATIONS	32
	MECHANICAL CHARACTERISTICS	33
	CHARACTERISTICS.....	34
	SERIALS.....	35
	POWER SUPPLY	35
CHAPTER	5. USER INTERFACE.....	36
	TM171VEV••	36
	TM171DLED	37
	ACCESS TO FOLDERS - MENU STRUCTURE	38
	MAIN DISPLAY	39
	STATUS MENU.....	40

	PROGRAMMING MENU	43
	MULTI FUNCTION KEY (PAR/FNC).....	45
	SETTING THE PASSWORD (PAR/PASS).....	45
CHAPTER	6. PHYSICAL I/O CONFIGURATION	46
	OVERVIEW.....	46
	ANALOG INPUTS.....	46
	DIGITAL INPUTS	48
	DIGITAL OUTPUTS	48
	DIP-SWITCH TABLE	49
CHAPTER	7. REGULATIONS	50
	INTRODUCTION.....	50
	PID CONTROL ALGORITHM	50
	THRESHOLD CONTROL ALGORITHM	51
	SUPERHEAT SETPOINT FROM REMOTE	52
	PLANT TYPE (DE21).....	52
	MOP (MAXIMUM OPERATING PRESSURE)	53
	MOP SETPOINT FROM REMOTE.....	53
	TM171VEV•• AS ACTUATOR FROM REMOTE	53
	VALVE ACTIVATION WITH FIXED PERCENTAGE.....	53
CHAPTER	8. PRACTICAL EXAMPLES.....	54
	SINGLE ACTUATOR	54
	STAND-ALONE.....	55
CHAPTER	9. M171 OPTIMIZED PROGRAMMING STICK (TM171AMFK). 57	
	OVERVIEW.....	57
	DIP-SWITCH LEADS	58
	UPLOAD/DOWNLOAD VIA DIP-SWITCH.....	58
	UPLOAD/DOWNLOAD VIA TM171DLED.....	59
	DOWNLOAD FROM M171 OPTIMIZED PROGRAMMING STICK (TM171AMFK). 60	
CHAPTER	10. SUPERVISION.....	62
	CONFIGURATION WITH MODBUS RTU.....	62
	DATA FORMAT (RTU)	62
	DEVICE ADDRESS CONFIGURATION	63
	PARAMETER ADDRESS CONFIGURATION.....	63
	CONFIGURATION OF VARIABLE ADDRESSES/STATES	63

CHAPTER	11. ALARMS.....	64
	ALARMS TABLE	64
CHAPTER	12. PARAMETERS (PAr).....	66
	PARAMETERS/ VISIBILITY.....	68
	VALVE CONFIGURATION PARAMETERS	75
	VALVE CONFIGURATION PARAMETERS WITH DE00 = 0	75
	VALVE CONFIGURATION PARAMETERS WITH DE00 ≠ 0	77
	FOLDER VISIBILITY TABLE	84
	RESOURCE TABLE	85

SAFETY INFORMATION



IMPORTANT INFORMATION

Notice

Read these instructions carefully, and look at the equipment to become familiar with the device before trying to install, operate, service, or maintain it. The following special messages may appear throughout this documentation or on the equipment to warn of potential hazards or to call attention to information that clarifies or simplifies a procedure.



The addition of this symbol to a "Danger" or "Warning" safety label indicates that an electrical hazard exists which will result in personal injury if the instructions are not followed.



This is the safety alert symbol. It is used to alert you to potential personal injury hazard. Obey all safety messages that follow this symbol to avoid possible injury or death.

DANGER

DANGER indicates a hazardous situation which, if not avoided, **will result in** death or serious injury.

WARNING

WARNING indicates a hazardous situation which, if not avoided, **could result in** death or serious injury.

CAUTION

CAUTION indicates a dangerous situation which, if not avoided, **could result in** minor or moderate injury.

NOTICE

NOTICE is used to address practices not related to physical injury.

Please Note

Electrical equipment should be installed, operated, serviced, and maintained only by qualified personnel. No responsibility is assumed by Schneider Electric for any consequences arising out of the use of this material.

A qualified person is one who has skills and knowledge related to the construction and operation of electrical equipment and its installation, and has received safety training to recognize and avoid the hazards involved.

Qualification of Personnel

Only appropriately trained persons who are familiar with and understand the contents of this manual and all other pertinent product documentation are authorized to work on and with this product.

The qualified person must be able to detect possible hazards that may arise from parameterization, modifying parameter values and generally from mechanical, electrical, or electronic equipment. The qualified person must be familiar with the standards, provisions, and regulations for the prevention of industrial accidents, which they must observe when designing and implementing the system.

Intended Use

The products described or affected by this document, together with software, accessories, and options, are controllers for bipolar stepper electronic expansion valves.

The products may only be used in compliance in accordance with all applicable safety regulations and directives, the specified requirements, and the technical data.

Prior to using the product, you must perform a risk assessment in view of the planned application. Based on the results, the appropriate safety-related measures must be implemented.

Since the product is used as a component in an overall machine or process, you must ensure the safety of persons by means of the design of this overall system.

It must be adequately protected from water and dust with regard to the application, and must only be accessible using a keyed or tooled locking mechanism (with the exception of the front panel).

The product is suitable for use in household refrigeration appliances and/or similar equipment and has been tested in accordance with the harmonized European reference standards.

Operate the product only with the specified cables and accessories. Use only genuine accessories and spare parts.

Any use other than the use explicitly permitted is prohibited and can result in unanticipated hazards.

Prohibited use

Any use other than that expressed above under Permitted use is strictly prohibited.

The relay contacts supplied are of an electromechanical type and subject to wear. Functional safety protection devices, specified in international or local standards, must be installed externally to this device.

Liability and Residual Risks

The liability of Schneider Electric is limited to the proper and professional use of this product under the guidelines contained in the present and other supporting documents, and does not extend to damages caused by (but not limited to):

- Unspecified installation/use and, in particular, in contravention of the safety requirements of established legislation or specified in this document
- Use on equipment which does not provide adequate protection against electrocution, water and dust in the actual installation conditions
- Use on equipment in which dangerous components can be accessed without the use of specific tools
- Installation/use on equipment which does not comply with established legislation and standards

Disposal



The appliance (or the product) must be disposed of separately in compliance with the local standards in force on waste disposal.

ABOUT THE BOOK



AT A GLANCE

Document scope

This document describes the **Modicon M171 Electronic Expansion Valve (TM171VEV••)** devices with bipolar electronic expansion valve (EEV), including information on installation and wiring.

Use the document to:

- Install and use your **TM171VEV••** device
- Become familiar with the functions of the **TM171VEV••** device

NOTE: Read this document and all related documents before installing, operating, or maintaining your controller.

Validity Note

This document is valid for **TM171VEV••** devices.

For product compliance and environmental information (RoHS, REACH, PEP, EOLI, etc.), go to www.schneider-electric.com/green-premium.

The technical characteristics of the devices described in this document are also available online. To access the information online:

Step	Action
1	Go to the Schneider Electric home page www.schneider-electric.com .
2	In the Search box type the reference of a product or the name of a product range. <ul style="list-style-type: none">• Do not include blank spaces in the reference or product range.• To get information on grouping similar modules, use asterisks (*).
3	If you entered a reference, go to the Product Datasheets search results and click on the reference that interests you. If you entered the name of a product range, go to the Product Ranges search results and click on the product range that interests you.
4	If more than one reference appears in the Products search results, click on the reference that interests you.
5	Depending on the size of your screen, you may need to scroll down to see the data sheet.
6	To save or print a data sheet as a .pdf file, click Download XXX product datasheet .

The characteristics that are presented in the present document should be the same as those characteristics that appear online. In line with our policy of constant improvement, we may revise content over time to improve clarity and accuracy. If you see a difference between the document and online information, use the online information as your reference.

Related documents

Title of documentation	Reference number
EcoStruxure Machine Expert - HVAC Software Quick Start	EIO0000002035 (ENG)
EcoStruxure Machine Expert - HVAC Software Programming Guide	EIO0000002036 (ENG)
EcoStruxure Machine Expert - HVAC HVAC&R Function Library User Guide	EIO0000002057 (ENG)
TM171 EEV driver Instruction Sheet	EAV96021
Modicon M171 Performance logic controllers Hardware User Manual	EIO0000002030 (ENG)
Modicon M171 Optimized logic controllers Hardware User Manual	EIO0000002032 (ENG)

You can download these technical publications and other technical information from our website at www.schneider-electric.com/en/download

Product related information

DANGER

HAZARD OF ELECTRIC SHOCK, EXPLOSION, ARC FLASH OR FIRE

- Disconnect all power from all equipment including connected devices, prior to removing any covers or doors, or installing or removing any accessories, hardware, cables, or wires except under the specific conditions specified in the appropriate hardware guide for this equipment.
- Always use the correctly rated voltage sensing device to confirm the power is off where and when indicated.
- Replace and secure all covers, accessories, hardware, cables and wires.
- Verify the earthing connections on all earthed devices.
- Use only the specified voltage when operating this equipment and any associated products.

Failure to follow these instructions will result in death or serious injury.

This equipment has been designed to operate outside of any hazardous location and exclusive of application that generate, or have the potential to generate, hazardous atmospheres. Only install this equipment in zones and applications known to be free, at all times, of hazardous atmospheres.

DANGER

POTENTIAL FOR EXPLOSION

- Install and use this equipment in non-hazardous locations only.
- Do not install and use this equipment in applications capable of generating hazardous atmospheres, such as those applications employing flammable refrigerants.

Failure to follow these instructions will result in death or serious injury.

For information concerning the use of control equipment in applications capable of generating hazardous materials, consult your local, regional or national standards bureau or certification agency.

WARNING

LOSS OF CONTROL

- The designer of any control scheme must consider the potential failure modes of control paths and for certain critical control functions, provide a means to achieve a safe state during and after a path failure. Examples of critical control functions are emergency stop and overtravel stop, power outage and restart.
- Separate or redundant control paths must be provided for critical control functions.
- System control paths may include communication links. Consideration must be given to the implications of unanticipated transmission delays or failures of the link.
- Observe all accident prevention regulations and local safety guidelines ⁽¹⁾.
- Each implementation of this equipment must be individually and thoroughly tested for proper operation before being placed into service.

Failure to follow these instructions can result in death, serious injury, or equipment damage.

⁽¹⁾ For additional information, refer to the standards NEMA ICS 1.1 (latest edition), "Safety Guidelines for the Application, Installation and Maintenance of Solid State Control" and NEMA ICS 7.1 (latest edition) "Safety Standards for Construction and Guide for Selection, Installation and Operation of Adjustable-Speed Drive Systems" or to equivalent standards that regulate your particular location.

WARNING

UNINTENDED EQUIPMENT OPERATION

- Only use software and hardware components approved by Schneider Electric for use with this equipment.
- Update your application program every time you change the physical hardware configuration.

Failure to follow these instructions can result in death, serious injury, or equipment damage.

Chapter 1

RANGE OVERVIEW

INTRODUCTION

GENERAL DESCRIPTION

Modicon M171 Electronic Expansion Valve (**TM171VEV**) is the compact solution of the Schneider Electric platform of drivers managing bipolar stepper electronic expansion valves suited for a range of needs in the HVAC/R market and other similar applications.

TM171VEV is available in various models, which can be used as single actuators or in “stand-alone” mode (via Digital inputs or RS-485 serial port). The models are available for DIN Rail or Panel mounting.

An M171 Optimized Display LED 32x74 terminal (**TM171DLED**) terminal is used to configure the parameters and operations performed on the device, connected to the Keyb serial port inside the door.

TM171VEV is provided with a serial port for the Modbus RTU serial communication standard interface and the option of downloading parameter maps and applications via the M171 Optimized Programming stick (**TM171AMFK**).

All digital inputs and digital outputs are independent and configurable.
The power supply rating is 24 Vac/dc.

PROGRAMMING SOFTWARE

In association with the controllers hardware, the EcoStruxure Machine Expert - HVAC V1.0 (**TM171SW**) development tool is available to Read/Write parameters and resources.

You can download EcoStruxure Machine Expert - HVAC - Programming Software for Modicon **M171 Electronic Expansion Valve** from [Schneider-electric web site download center](#).

The use of several programming languages in accordance with IEC 61131-3 regulations (programming standard for industrial control), makes it possible to develop new algorithms or entire programs, which can then be uploaded to the M172 model controllers via a PC and a Programming cable.

MAIN FUNCTIONS

The main functions of the **TM171VEV** are as follows:

- Regulates the superheating value at the evaporator output
- Refrigerant type selected via selectors (dip-switches) under the door
- Backup probes control saturation and evaporator output (superheat)
- Valve state shown via LEDs
- Parameter settings via **TM171DLED**, **TM171AMFK** or **TM171SW**
- Firmware update via **TM171AMFK**
- **TM171DLED** terminal (up to 10 m - 32.8 ft) that can be connected directly
- Configurable inputs NTC, Pt1000, 4...20 mA, 0...10 V, 0...5 V ratiometric
- 2 Digital Outputs for control valve and/or alarms

In this manual, the photographs and drawings help to demonstrate the **TM171VEV** device (and other Schneider-electric devices) and are purely illustrative. The relative dimensions and proportions may not correspond to the actual dimensions, nor are actual size or in scale. Moreover, all wiring and electrical diagrams are to be considered as simplified representations which may not correspond to the actual situation.





ACCESSORIES

OVERVIEW

This section describes the accessories and sensors.

ACCESSORIES REFERENCES

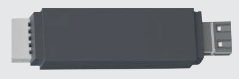
Depending on your application requirements, the following accessories may be purchased separately:

	References	Description
	TM171DLED	M171 Optimized Display LED. 32x74 terminal
	TM171AMFK	M171 Optimized Programming stick
	TM1STNTCSF44015 TM1STNTCSF44030 TM1STNTCTN62015 TM1STNTCTN62030	NTC 1,5 m FAST IP67 4x40 -50+110°C Grey NTC 3 m FAST IP67 4x40 -50+110°C Grey NTC 1,5 m IP68 6x20 TPE w/ strap Grey NTC 3 m FAST IP67 4x40 -50+110°C Grey
	TM171ADMI	M171 Optimized Programming cable
	TM171ASCTBVEV	M171 Electronic Expansion Valve driver Screw Terminal Blocks

CONTENTS OF PACK

Delivery Content

The image below shows the contents of the package of an **TM171VEV** device.

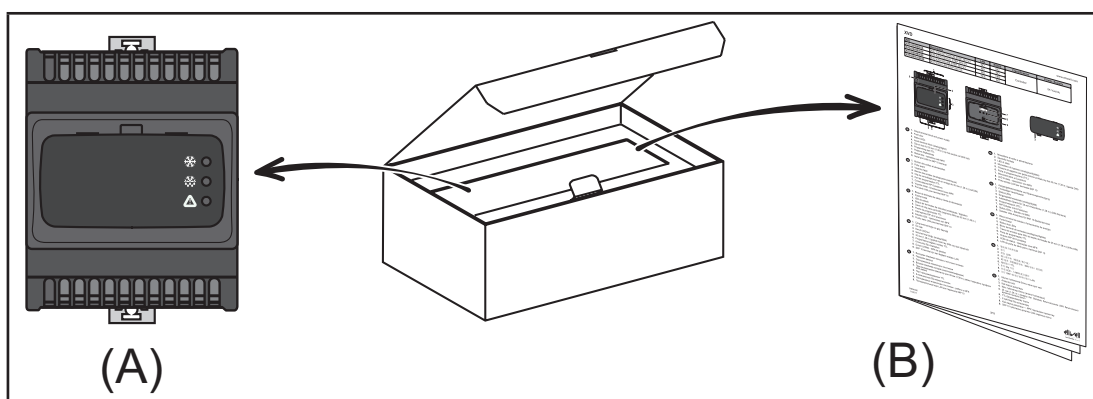

The following can be found in the package:

Label	Description
A	TM171VEV device
B	Instruction Sheet TM171VEV

Chapter 2

MECHANICAL INSTALLATION

BEFORE STARTING

BEFORE STARTING

Read this chapter before beginning the installation of your system.

Pay particular attention in conforming to any safety information, different electrical requirements and normative standards that would apply to your machine or process in the use of this equipment.

The use and application of the information contained herein require expertise in the design and programming of automated control systems. Only you, the user, machine builder or integrator, can be aware of all the conditions and factors present during installation and setup, operation and maintenance of the machine or process and can therefore determine the automation and associated equipment and the related safeties and interlocks which can be effectively and properly used. When selecting automation and control equipment and any other related equipment or software, for a particular application, you must also consider any applicable local, regional or national standards and/or regulations.

WARNING

REGULATORY INCOMPATIBILITY

Ensure that all equipment used and the systems designed comply with all applicable local, regional and national laws.

Failure to follow these instructions can result in death, serious injury, or equipment damage.

DISCONNECTING POWER

All options and modules should be assembled and installed before installing the control system on a mounting rail, onto a mounting plate or in a panel. Remove the control system from its mounting rail, mounting plate or panel before disassembling the equipment.

DANGER

HAZARD OF ELECTRIC SHOCK, EXPLOSION, ARC FLASH OR FIRE

- Disconnect all power from all equipment including connected devices, prior to removing any covers or doors, or installing or removing any accessories, hardware, cables, or wires except under the specific conditions specified in the appropriate hardware guide for this equipment.
- Always use the correctly rated voltage sensing device to confirm the power is off where and when indicated.
- Replace and secure all covers, accessories, hardware, cables and wires.
- Verify the earthing connections on all earthed devices.
- Use only the specified voltage when operating this equipment and any associated products.

Failure to follow these instructions will result in death or serious injury.

PROGRAMMING CONSIDERATIONS

The products described in this manual have been designed and tested using Schneider Electric programming, configuration and maintenance software products.

WARNING

UNINTENDED EQUIPMENT OPERATION

- Only use software and hardware components approved by Schneider Electric for use with this equipment.
- Update your application program every time you change the physical hardware configuration.

Failure to follow these instructions can result in death, serious injury, or equipment damage.

OPERATING ENVIRONMENT

This equipment has been designed to operate outside of any hazardous location and exclusive of application that generate, or have the potential to generate, hazardous atmospheres. Only install this equipment in zones and applications known to be free, at all times, of hazardous atmospheres.

DANGER

POTENTIAL FOR EXPLOSION

- Install and use this equipment in non-hazardous locations only.
- Do not install and use this equipment in applications capable of generating hazardous atmospheres, such as those applications employing flammable refrigerants.

Failure to follow these instructions will result in death or serious injury.

For information concerning the use of control equipment in applications capable of generating hazardous materials, consult your local, regional or national standards bureau or certification agency.

WARNING

UNINTENDED EQUIPMENT OPERATION

Install and operate this equipment according to the conditions described in the Environmental Characteristics.

Failure to follow these instructions can result in death, serious injury, or equipment damage.

INSTALLATION CONSIDERATIONS

WARNING

UNINTENDED EQUIPMENT OPERATION

- Use appropriate safety interlocks where personnel and/or equipment hazards exist.
- Install and operate this equipment in an enclosure appropriately rated for its intended environment and secured by a keyed or tooled locking mechanism.
- Power line and output circuits must be wired and fused in compliance with local and national regulatory requirements for the rated current and voltage of the particular equipment.
- Do not use this equipment in safety-critical machine functions unless the equipment is otherwise designated as functional safety equipment and conforming to applicable regulations and standards.
- Do not disassemble, repair, or modify this equipment, unless otherwise expressly indicated.
- Do not connect any wiring to unused connections, or to connections designated as No Connection (NC).

Failure to follow these instructions can result in death, serious injury, or equipment damage.

For mechanical dimensions, see '**MECHANICAL CHARACTERISTICS**' on page 33.

TM171VEV devices are intended for Top Hat Section Rail (DIN rail) mounting.

Care must be taken to avoid damage from electrostatic sources when handling this equipment. In particular exposed connectors and, in some cases, exposed printed circuit boards are exceptionally vulnerable to electrostatic discharge.

WARNING

INCORRECT OPERATION OF EQUIPMENT DUE TO ELECTROSTATIC DISCHARGE

- Store the equipment in the protective packaging until ready for installation.
- The device must only be installed in type-approved cabinets and/or in points that prevent unauthorized access and provide protection from electrostatic discharge.
- When handling sensitive equipment, use an earthed protective device against electrostatic discharge
- Before handling the device, always discharge the static electricity from the body by touching an earthed surface or type-approved antistatic mat.

Failure to follow these instructions can result in death, serious injury, or equipment damage.

TM171VEV•• INSTALLATION

DIN RAIL MOUNTING

For installation proceed as follows:

1. Move the lower locking clip at the bottom outwards as shown in the diagram below (lever with a screwdriver or similar tool). Be sure to keep the upper locking clip located on top fully inserted
2. Mount the device on the DIN rail
3. Press the clips inwards to lock

NOTE: Once assembled on the DIN RAIL, verify that the spring hocking devices are turned downwards.

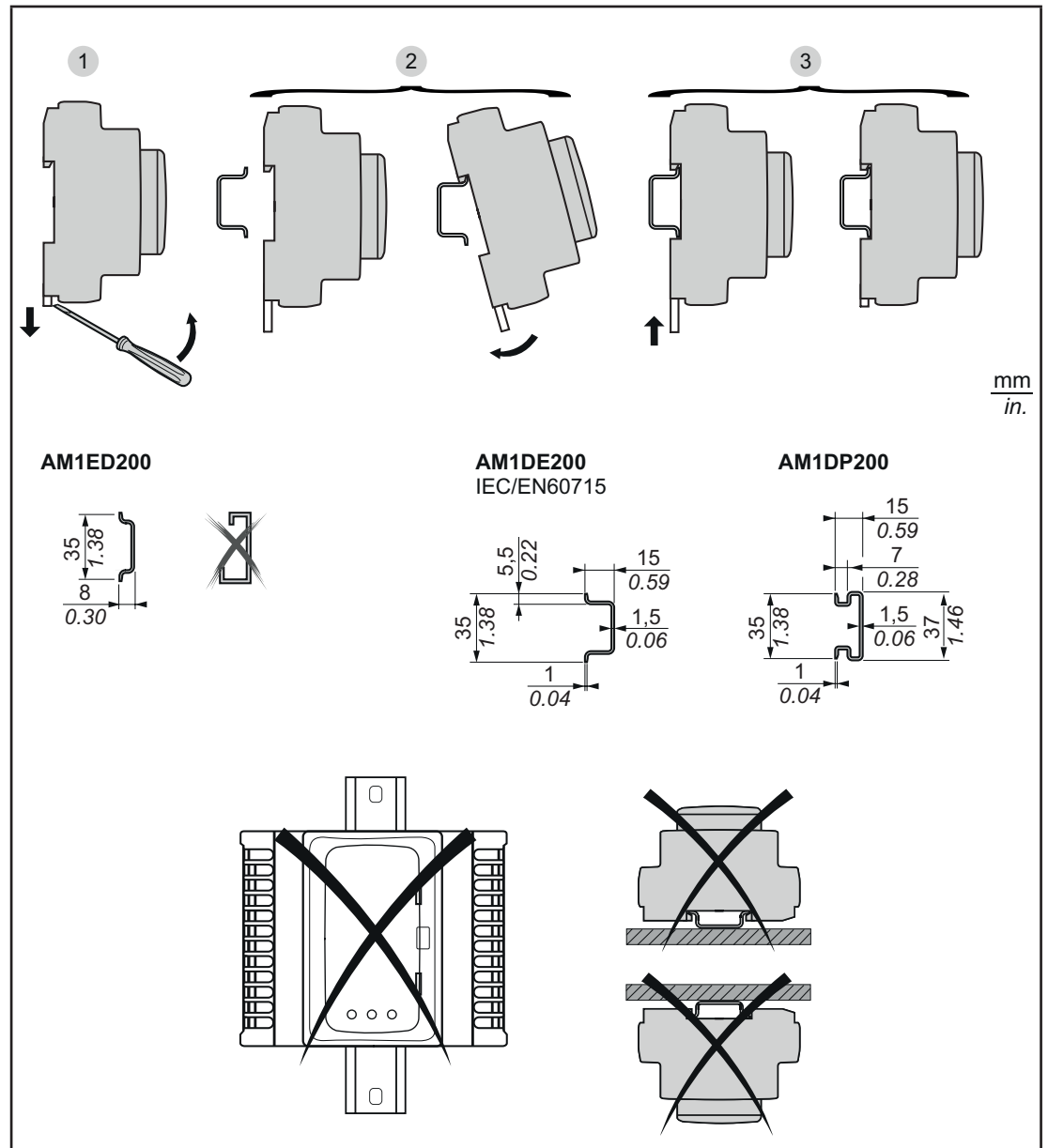

Fig. 1. DIN Rail installation

PANEL MOUNTING

For installation proceed as follows:

1. Move the two locking clips outwards as shown in the diagram below (lever with a screwdriver or similar tool)
2. Mount the device on the Panel
3. Secure the device with two screws (not provided)

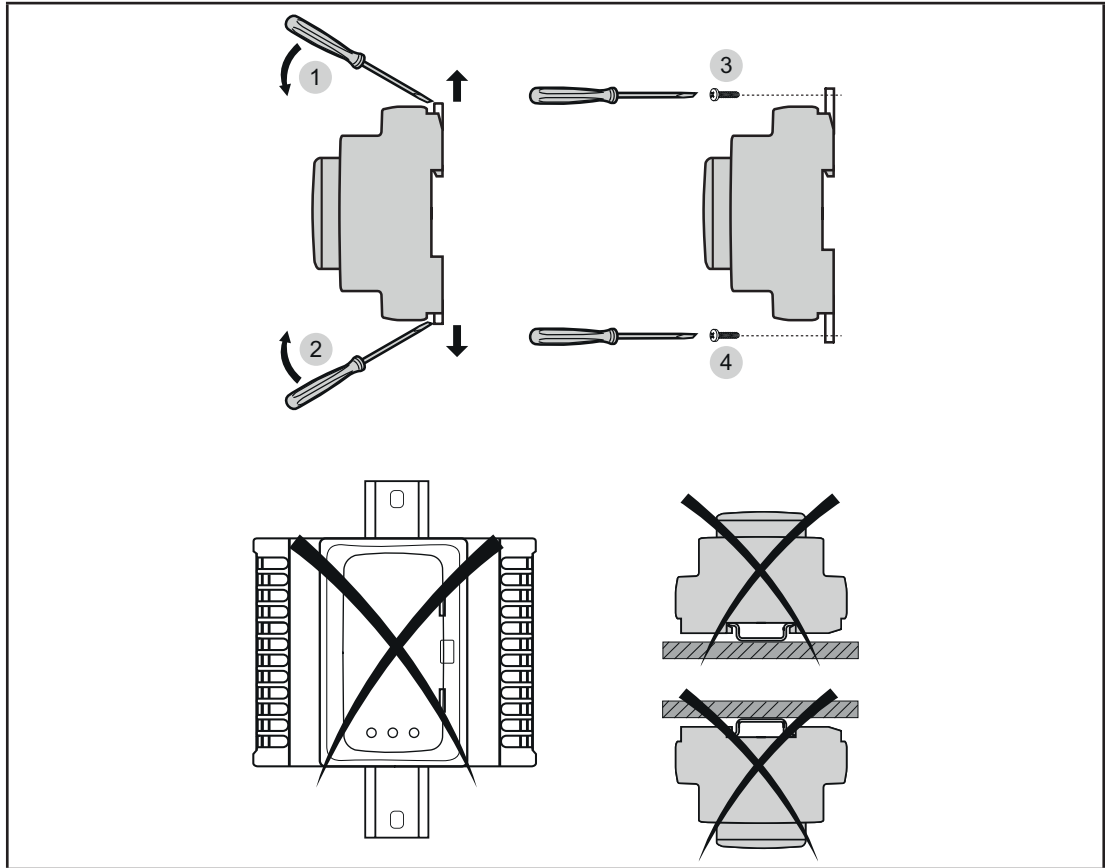

Fig. 2. Panel installation

MOUNTING

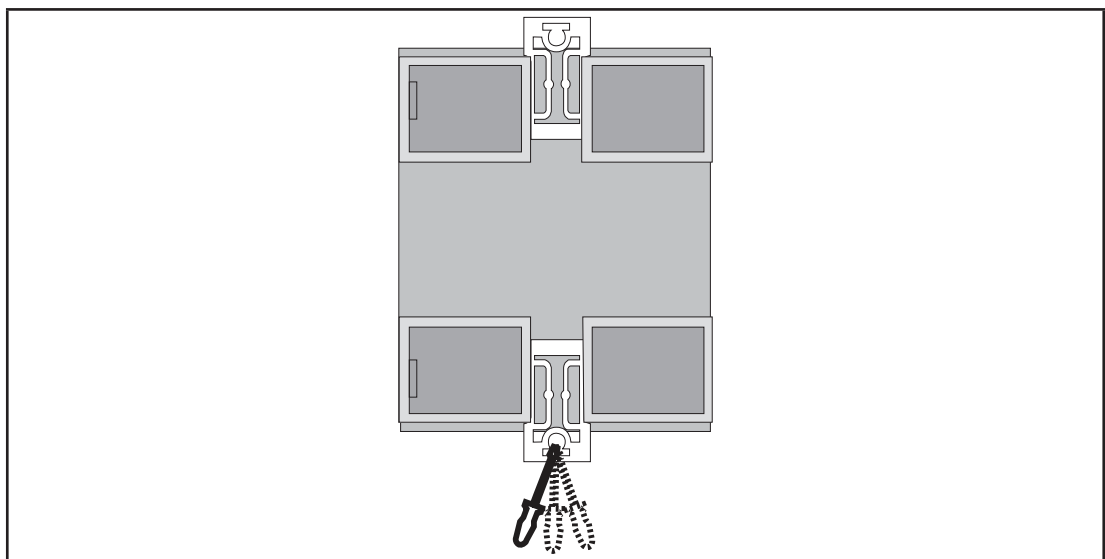

Fig. 3. Detail of spring hooking devices

The **TM171VEV••** device was designed as an IP20 product installed only in type-approved cabinets and/or in points that block access to unauthorized persons.

When installing the device, comply with these distances:

- Between **TM171VEV••** and all sides of the cabinet (including the panel door).
- The terminal boards on the **TM171VEV••** and the wiring cable trays. These distances reduce the electromagnetic interference between the device and the wiring cable trays.
- The **TM171VEV••** and the other heat-generating devices installed in the same cabinet.

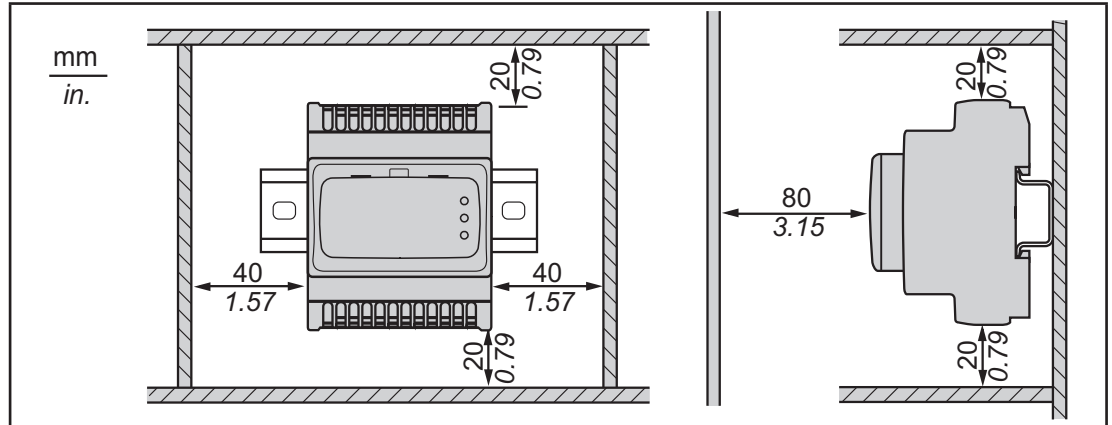

Fig. 4. Distances

⚠ WARNING

UNINTENDED EQUIPMENT OPERATION

- Place the devices dissipating the most heat in the top of the cabinet and ensure suitable ventilation.
- Do not place this equipment near or above any devices which could cause superheat.
- Install the device in a point that guarantees the minimum distances from all structures and adjacent equipment as indicated in this document.
- Install all equipment in conformity with the technical specifications given in the respective documentation.

Failure to follow these instructions can result in death, serious injury, or equipment damage.

ACCESS TO DIP-SWITCHES

When handling the equipment, use caution to avoid damage caused by electrostatic discharge. In particular, the unshielded connectors and in certain cases the open circuit boards are vulnerable to electrostatic discharge.

⚠ WARNING
UNINTENDED EQUIPMENT OPERATION DUE TO ELECTROSTATIC DISCHARGE
<ul style="list-style-type: none">• Store the equipment in the packaging until ready for installation.• The device must only be installed in type-approved cabinets and/or in points that prevent unauthorized access and provide protection from electrostatic discharge.• When handling sensitive equipment, use an earthed protective device against electrostatic discharge.• Before handling the device, always discharge the static electricity from the body by touching an earthed surface or type-approved antistatic mat.
Failure to follow these instructions can result in death, serious injury, or equipment damage.

For access to the dip-switches proceed as follows:

1. Use a straight-edge screwdriver to remove the panel
2. Carefully configure the selectors (dip-switches)
3. Close the front of the keyboard by pressing with your fingers

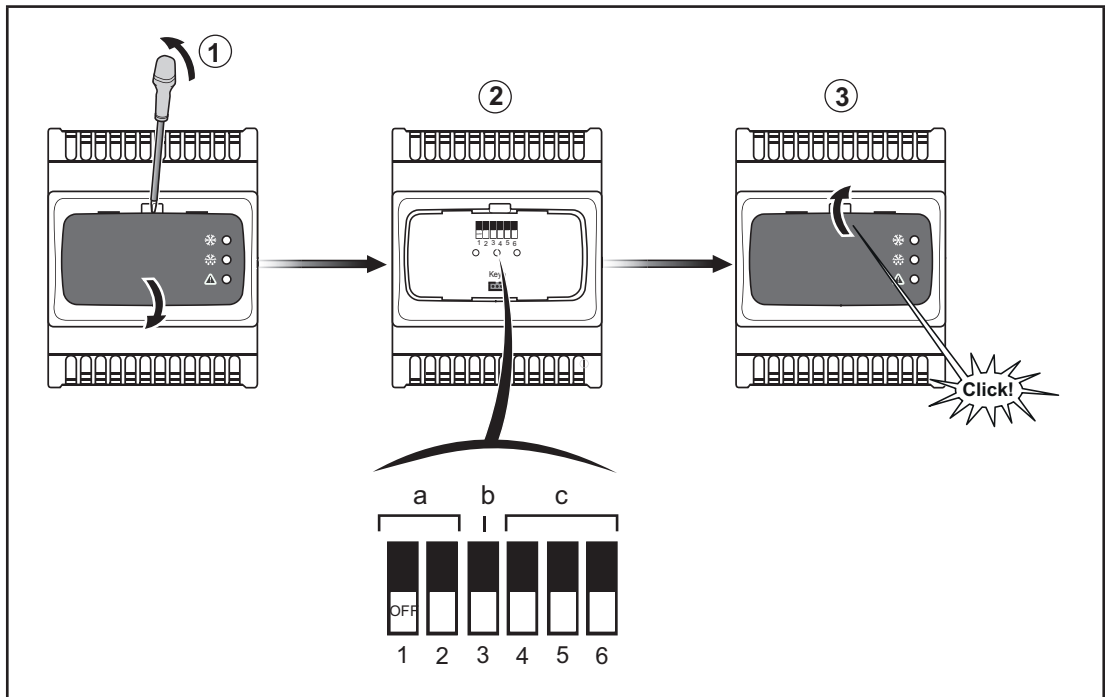

Fig. 5. dip-switches

The dip-switches are used to set the following:

- **a.** (DIP 1-2) Used to activate the upload or download of parameters from the M171 Optimized Programming stick (**TM171AMFK**)
- **b.** (DIP 3) Used to select the network address
- **c.** (DIP 4-5-6) Used to choose the refrigerant

To set dip-switches, see '**DIP-SWITCH TABLE**' on page 49.

Chapter 3

ELECTRICAL CONNECTIONS

WIRING BEST PRACTICES

The following information describes the wiring guidelines and associated best practices to be respected when using a **TM171VEV** driver.

DANGER

HAZARD OF ELECTRIC SHOCK, EXPLOSION, ARC FLASH OR FIRE

- Disconnect all power from all equipment including connected devices, prior to removing any covers or doors, or installing or removing any accessories, hardware, cables, or wires except under the specific conditions specified in the appropriate hardware guide for this equipment.
- Always use the correctly rated voltage sensing device to confirm the power is off where and when indicated.
- Replace and secure all covers, accessories, hardware, cables and wires.
- Verify the earthing connections on all earthed devices.
- Use this equipment and all connected products only at the specified voltage.

Failure to follow these instructions will result in death or serious injury.

WARNING

LOSS OF CONTROL

- The installation designer must consider the potential failure modes of the control circuit and for some critical control functions, provide a means for reaching a safe condition during and after a circuit failure. Examples of critical control functions are the emergency stop and end of travel stop, power supply cut-off and restarting.
- Separate or redundant control circuits must be provided for critical control functions.
- The system control circuits can include communication connections. Keep in mind the implications of transmission delays or sudden connection failures.
- Comply with all the standards regarding accident protection and the local applicable safety directives ⁽¹⁾.
- Every implementation of this device must be tested individually and completely in order to verify its proper operation before putting it in service.

Failure to follow these instructions can result in death, serious injury, or equipment damage.

⁽¹⁾ For additional information, refer to the standards NEMA ICS 1.1 (latest edition), “Safety Guidelines for the Application, Installation and Maintenance of Solid State Control” and NEMA ICS 7.1 (latest edition) “Safety Standards for Construction and Guide for Selection, Installation and Operation of Adjustable-Speed Drive Systems” or to equivalent standards that regulate your particular location.

WIRING GUIDELINES

The following rules must be applied when wiring **TM171VEV** device:

- Verify that the operating conditions and surroundings environment are within the specification values
- I/O and communication wiring must be kept separate from the power wiring. Route these 2 types of wiring in separate cable ducting
- Use correct wire sizes to meet voltage and current requirements
- Use copper conductors
- Use twisted-pair, shielded cables for networks, and field bus
- Use twisted pair, shielded cables for probes

⚠ WARNING

UNINTENDED EQUIPMENT OPERATION

- Use shielded cables for networks and fieldbus.
- Ground cable shields for analog I/O and communication signals at a single point ⁽¹⁾.
- The signal cables (probes, digital inputs, communication and relative power supplies) of the device must be routed separately from the power cables.
- Reduce the length of the wires and cables as much as possible and avoid winding them around electrically connected parts.

Failure to follow these instructions can result in death, serious injury, or equipment damage.

⁽¹⁾ Multipoint grounding is permissible if connections are made to an equipotential ground plane dimensioned to help avoid cable shield damage in the event of power system short-circuit currents.

NOTE: Surface temperatures may exceed 60 °C (140 °F).

RULES FOR REMOVABLE SCREW TERMINAL BLOCKS

The following table presents the cable types and wire sizes for a **5.00 mm (0.197 in.)** pitch screw terminal block (see accessory **TM171ASCTBVEV**).

mm in.	7 0.28							
mm ²	0.2...2.5	0.2...2.5	0.25...2.5	0.25...2.5	2 x 0.2...1	2 x 0.2...1.5	2 x 0.25...1	2 x 0.5...1.5
AWG	24...14	24...14	22...14	22...14	2 x 24...18	2 x 24...16	2 x 22...18	2 x 20...16

		N•m	0.5...0.6
Ø 3,5 mm (0.14 in.)		lb-in	4.42...5.31

The use of copper conductors is required.

⚠ ⚠ DANGER

LOOSE WIRING CAN RESULT IN ELECTRIC SHOCK

- Tighten connections in conformance with the torque specifications.
- Do not insert more than one wire per connector of the terminal block unless using the cable ends (ferrules) specified above.

Failure to follow these instructions will result in death or serious injury.

⚠ DANGER

FIRE HAZARD

- Use only the recommended wire sizes for the current capacity of the I/O channels and power supplies.
- For common conductors of relay output wiring use conductors of at least 2.0 mm² (AWG 12) with a temperature rating of at least 80 °C (176 °F).

Failure to follow these instructions will result in death or serious injury.

PROTECTION OF OUTPUTS FROM DAMAGE FROM INDUCTIVE LOADS

The device relay output can support up to 240 Vac.

Damage from inductive loads to this type of output can cause the contacts to weld and lead to the loss of control. Each inductive load must include a protective device such as a peak limiter or snubber. This relay do not support capacitive loads.

⚠ WARNING

RELAY OUTPUTS WELDED TO CLOSED POSITION

- Use a suitable external protective device or circuit on all relay outputs connected to alternate current inductive loads.
- Do not connect the relay outputs to capacitive loads.

Failure to follow these instructions can result in death, serious injury, or equipment damage.

Depending on the load, a protection circuit may be needed for the relay output.

⚠ CAUTION

OUTPUT CIRCUIT DAMAGE DUE TO INDUCTIVE LOADS

Use an appropriate external protective circuit or device to reduce the risks of voltage impulses in the switching of inductive loads.

Failure to follow these instructions can result in injury or equipment damage.

Protection circuit A: this protection circuit uses a snubber and can be used for alternating current circuits. The snubber must be compatible with the type of load and the RMS voltage of the snubber must be +10% greater than the load voltage (for example: with a load working at 250 Vac, the snubber must have a minimum voltage of 275 Vac).

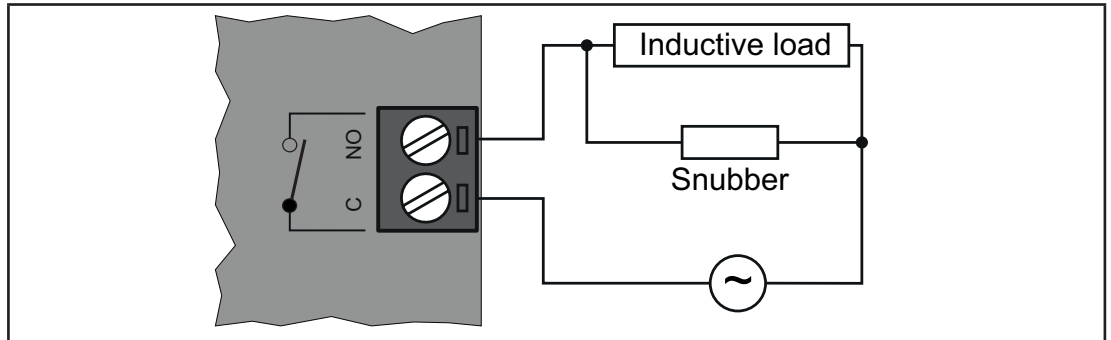

Fig. 6. Protection circuit A

Protection circuit B: this protection circuit uses a varistor and can be used for alternating current circuits. In applications in which the inductive load is frequently and/or rapidly energized and de-energized, verify that the maximum continuous energy (U) of the varistor is 20% or greater than the peak load energy and the clamping voltage on the varistor is not less than 1.6 times the load voltage.

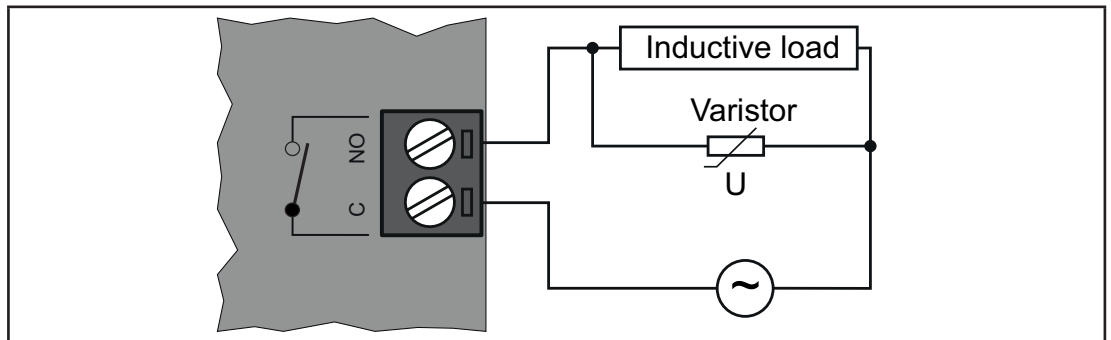

Fig. 7. Protection circuit B

NOTE: Place the protection devices as close as possible to the load.

SPECIFIC CONSIDERATIONS ON HANDLING

Care must be taken to avoid damage from electrostatic sources when handling this equipment. In particular exposed connectors and, in some cases, exposed printed circuit boards are exceptionally vulnerable to electrostatic discharge.

⚠ WARNING
INCORRECT OPERATION OF EQUIPMENT DUE TO ELECTROSTATIC DISCHARGE
<ul style="list-style-type: none">• Keep equipment in the packaging until you are ready to install the equipment.• The device must only be installed in type-approved cabinets and/or in points that prevent unauthorized access and provide protection from electrostatic discharge.• Use a conductive wrist strap or equivalent field force protective device attached to an earth ground when handling sensitive equipment.• Always discharge yourself by touching a grounded surface or approved antistatic mat before handling the equipment.
Failure to follow these instructions can result in death, serious injury, or equipment damage.

Before operating, verify that the device is connected to a suitable external power supply (see '**POWER SUPPLY**' on page 35).

ELECTRONIC EXPANSION VALVE

Before connecting the valve, carefully configure the **TM171VEV** driver by selecting the type of valve from the valves list (refer to '**RANGE**' on page 11).

⚠ WARNING
UNINTENDED EQUIPMENT OPERATION
<ul style="list-style-type: none">• Verify the correct selection of valve model (see dE00 parameter).• Verify the valve parameters and data provided by the valve manufacturer before using the valve.
Failure to follow these instructions can result in death, serious injury, or equipment damage.

Always disconnect the equipment's power supply before carrying out any maintenance on the electrical connections.

For a correct connection, adhere to the following:

- Separate the cables of probes and digital inputs from inductive loads and dangerous voltage connections to prevent any electromagnetic interference. Do not place the probe cables near other electrical equipment (switches, meters, etc.)
- Make connections as short as possible and do not wind them around electrically connected parts

ANALOG INPUTS - PROBES

Temperature probes have no connection polarity and can be extended using a normal twisted-pair cable. The extension of the probes wiring influences the electromagnetic compatibility (EMC) of the instrument. Verify the polarity for probes which have a specific connection polarity.

WARNING

INCORRECT OPERATION OF EQUIPMENT DUE TO CONNECTIONS

- Ensure that the controller has power applied when applying power to other connected and externally powered devices.
- Signal leads (probes, digital inputs, communication and relative power supplies) must be routed separately from power cables.

Failure to follow these instructions can result in death, serious injury, or equipment damage.

NOTICE

INOPERABLE DEVICE

Verify all wiring connections before applying power.

Failure to follow these instructions can result in equipment damage.

SERIAL CONNECTIONS

Verify wiring when connecting the serial line. A connection error could cause unintended operation or inoperable equipment.

Label	Description
TTL	TTL serial port present on the upper part of the device for connection to M171 Optimized Programming cable (TM171ADMI) or M171 Optimized Programming stick (TM171AMFK). Use the yellow 5-wire TTL cable up to 300 mm (11.81 in.) in length supplied. Contact Schneider Electric Sales Office for item availability.
Keyb	3-wire voltage serial port inside the door for connection to the M171 Optimized Display LED 32x74 terminal (TM171DLED) terminal. Maximum distance 10 m (32.8 ft).

DANGER

HAZARD OF ELECTRIC SHOCK

- The Keyb connection must only be used to configure the device and to view the resources.
- Close the front panel of the driver at the end of the configuration.

Failure to follow these instructions will result in death or serious injury.

WIRING DIAGRAMS

Refer to the following color codes in the following wiring diagrams:

Code (DIN IEC 757)	Color
BK	Black
BU	Blue
BN	Brown
RD	Red
WH	White
YE	Yellow

NOTICE

INOPERABLE DEVICE

Verify all wiring connections before applying power.

Failure to follow these instructions can result in equipment damage.

TM171VEVM4

	Label	Terminal	Description	
OPEN COLLECTOR	DO2	2	Open Collector output for connection to an external relay (for example SSR relay).	
	12 Vdc	3	12 Vdc power supply output. Maximum current: 100 mA.	
STEPPER VALVE OUTPUT	W2-	4	W2 terminals for connection to valve second coil winding.	
	W2+	5		
	W1-	6	W1 terminals for connection to valve first coil winding.	
	W1+	7		
POWER SUPPLY	\sim / +	8	Power supply V_{\sim} (+). In case of Vdc power supply respect the polarity.	
	\sim / -	9	Power supply V_{\sim} (-). In case of Vdc power supply respect the polarity.	
NC	---	10	Terminal not connected.	
DIGITAL OUTPUT	DO1	NO	11	DO1 relay Normally Open. For solenoid valve or alarm.
		C	12	DO1 relay Common terminal.
KEYB CONNECTION	GND	25	0 V signal reference.	
	DATA	26	Keyboard data terminal.	
	12 V	27	12 Vdc power output for keyboard.	
RS-485	-	14	"-" signal for RS-485 serial port.	
	+	15	"+" signal for RS-485 serial port.	
	G	16	0 V signal reference RS-485.	
DIGITAL INPUTS	DI1	17	Digital input 1.	
	DI2	18	Digital input 2.	
GROUND	GND	19	0 V common connection for: digital inputs (DI1, DI2). analog inputs (AI1, AI2, AI3, AI4).	
5 Vdc	5 V	20	5 Vdc power supply for ratiometric transducer.	
ANALOG INPUTS	AI1	21	Analog input 1.	
	AI2	22	Analog input 2.	
	AI3	23	Analog input 3.	
	AI4	24	Analog input 4.	

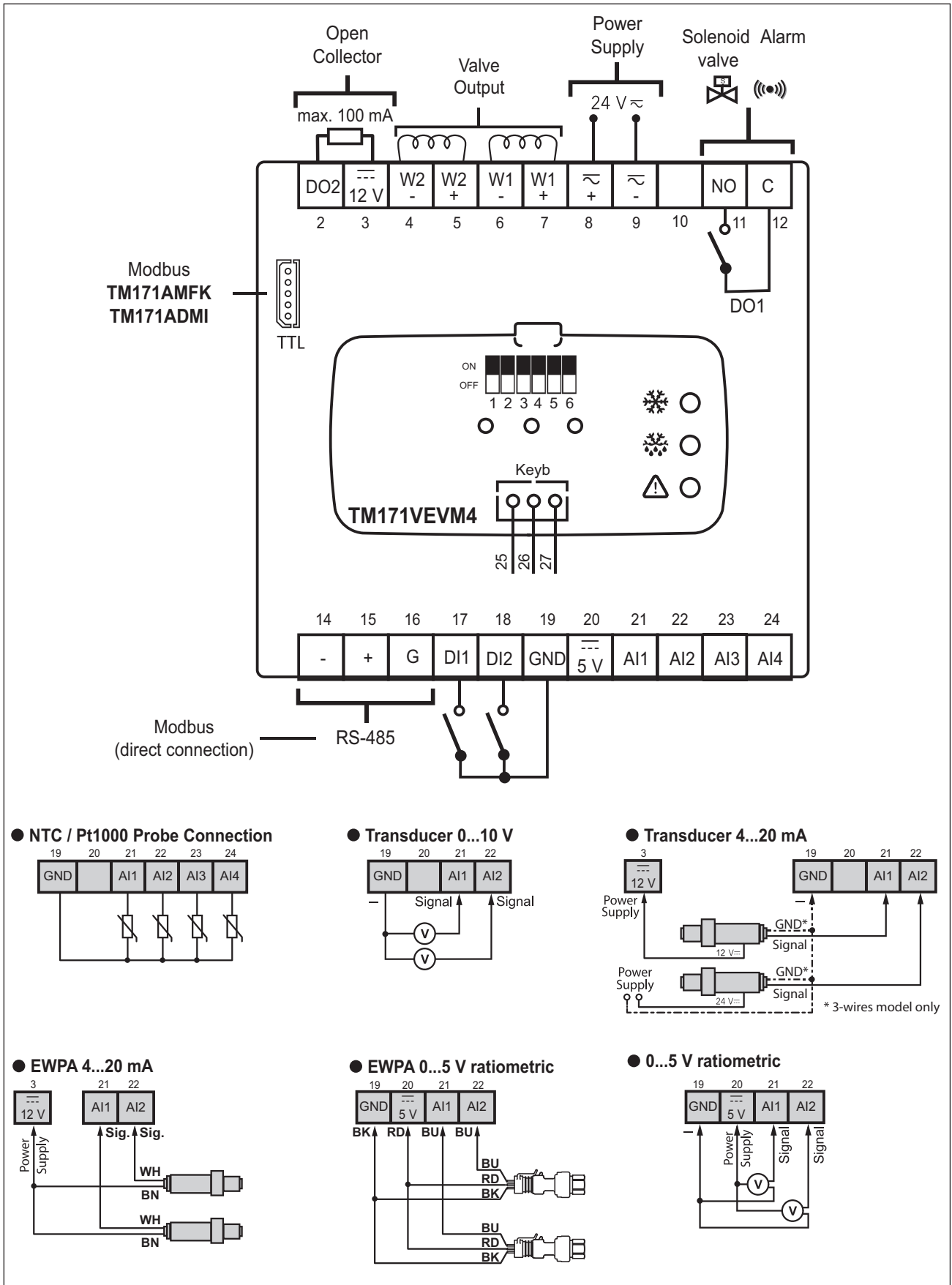
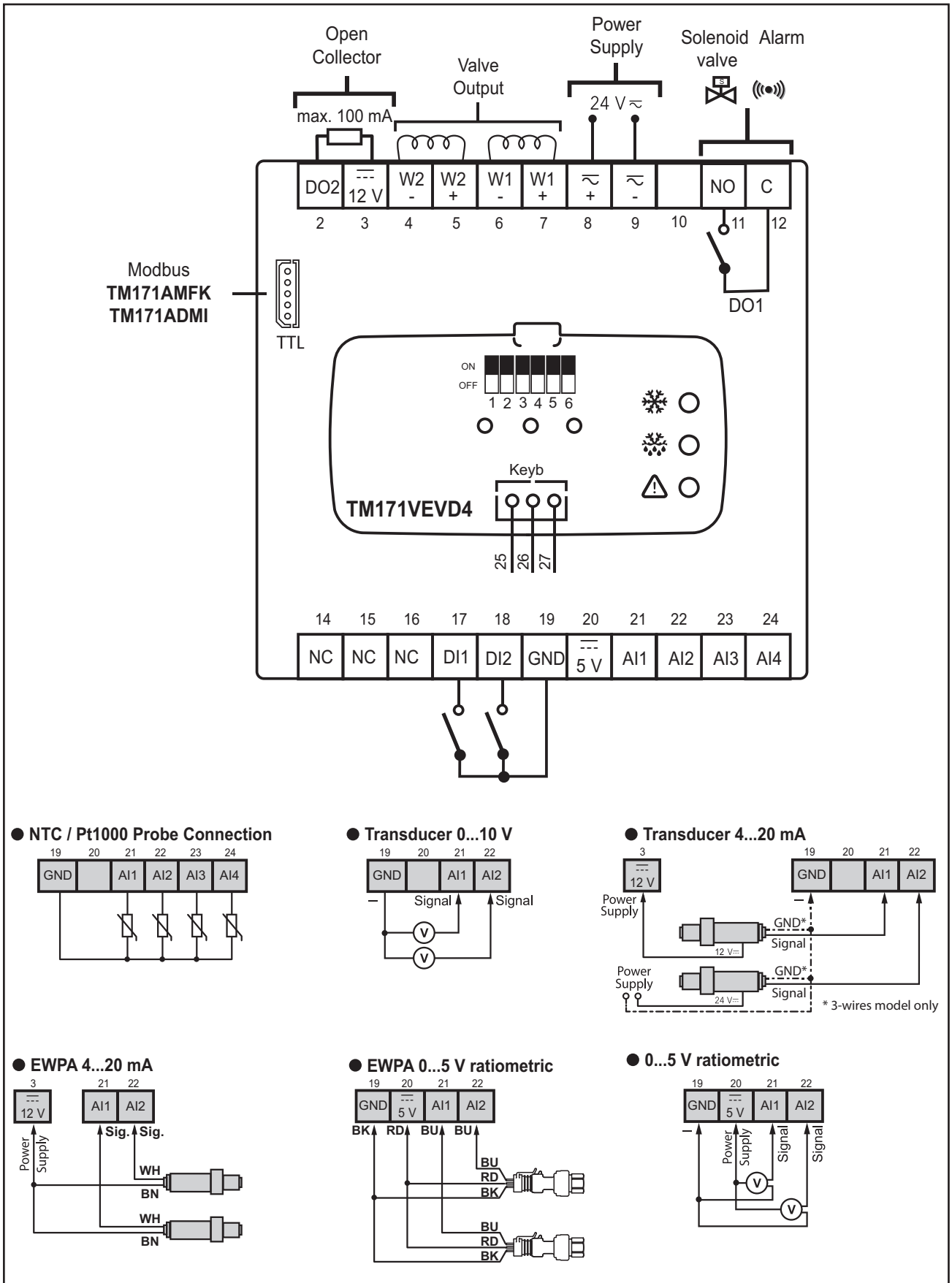

Fig. 8. TM171VEVM4 wiring diagram

TM171VEVD4

	Label	Terminal	Description	
OPEN COLLECTOR	DO2	2	Open Collector output for connection to an external relay (for example SSR relay).	
	12 Vdc	3	12 Vdc power supply output. Maximum current: 100 mA.	
STEPPER VALVE OUTPUT	W2-	4	W2 terminals for connection to valve second coil winding.	
	W2+	5		
	W1-	6	W1 terminals for connection to valve first coil winding.	
	W1+	7		
POWER SUPPLY	\sim / +	8	Power supply V_{\sim} (+). In case of Vdc power supply respect the polarity.	
	\sim / -	9	Power supply V_{\sim} (-). In case of Vdc power supply respect the polarity.	
NC	---	10	Terminal not connected.	
DIGITAL OUTPUT	DO1	NO	11	DO1 relay Normally Open. For solenoid valve or alarm.
		C	12	DO1 relay Common terminal.
KEYB CONNECTION	GND	25	0 V signal reference.	
	DATA	26	Keyboard data terminal.	
	12 V	27	12 Vdc power output for keyboard.	
NC	NC	14	Terminal not connected.	
NC	NC	15	Terminal not connected.	
NC	NC	16	Terminal not connected.	
DIGITAL INPUTS	DI1	17	Digital input 1.	
	DI2	18	Digital input 2.	
GROUND	GND	19	0 V common connection for: digital inputs (DI1, DI2). analog inputs (AI1, AI2, AI3, AI4).	
5 Vdc	5 V	20	5 Vdc power supply for ratiometric transducer.	
ANALOG INPUTS	AI1	21	Analog input 1.	
	AI2	22	Analog input 2.	
	AI3	23	Analog input 3.	
	AI4	24	Analog input 4.	



● NTC / Pt1000 Probe Connection

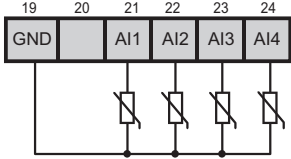

● Transducer 0...10 V

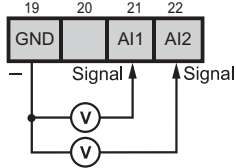

● Transducer 4...20 mA

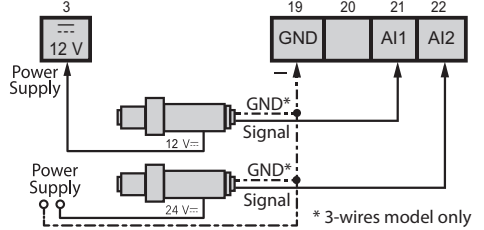

● EWPA 4...20 mA

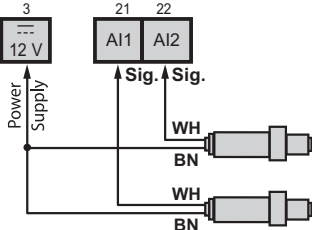

● EWPA 0...5 V ratiometric

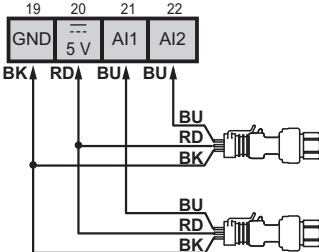

● 0...5 V ratiometric

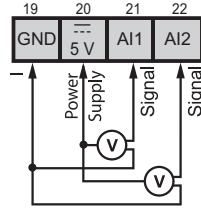
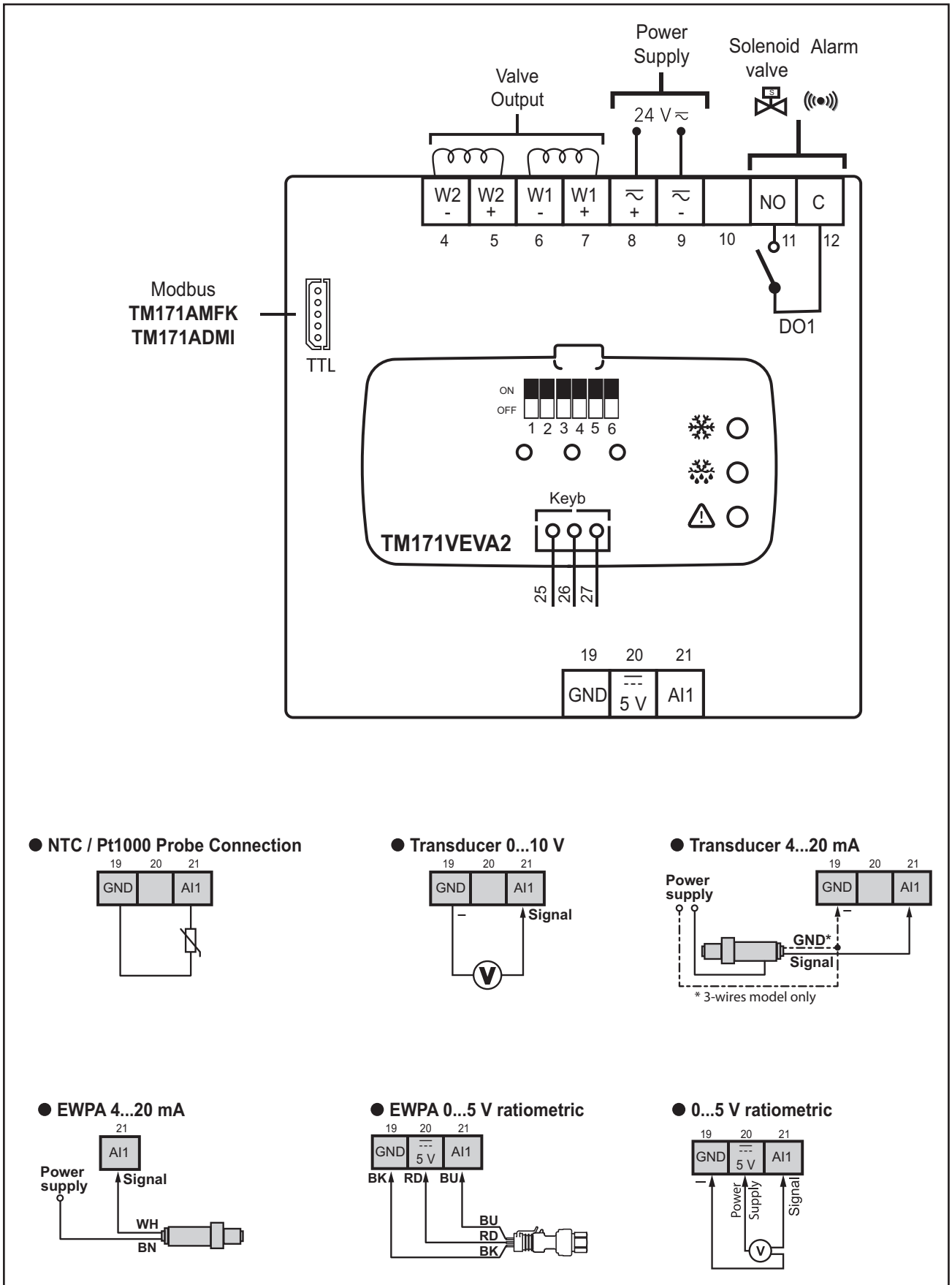

Fig. 9. TM171VEVD4 Wiring diagram

TM171VEVA2

	Label	Terminal	Description	
STEPPER VALVE OUTPUT	W2-	4	W2 terminals for connection to valve second coil winding.	
	W2+	5		
	W1-	6	W1 terminals for connection to valve first coil winding.	
	W1+	7		
POWER SUPPLY	$\sim / +$	8	Power supply V_{\sim} (+). In case of Vdc power supply respect the polarity.	
	$\sim / -$	9	Power supply V_{\sim} (-). In case of Vdc power supply respect the polarity.	
NC	---	10	Terminal not connected.	
DIGITAL OUTPUT	DO1	NO	11	DO1 relay Normally Open. For solenoid valve or alarm.
		C	12	DO1 relay Common terminal.
KEYB CONNECTION	GND	25	0 V signal reference.	
	DATA	26	Keyboard data terminal.	
	12 V	27	12 Vdc power output for keyboard.	
GROUND	GND	19	0 V common connection for analog input AI1.	
5 Vdc	5 V	20	5 Vdc power supply for ratiometric transducer.	
ANALOG INPUT	AI1	21	Analog input 1.	



● NTC / Pt1000 Probe Connection

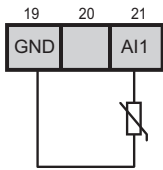

● Transducer 0...10 V

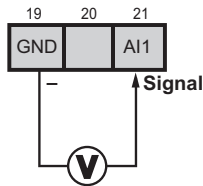

● Transducer 4...20 mA

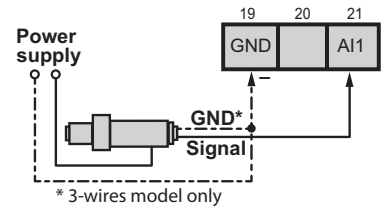

● EWPA 4...20 mA

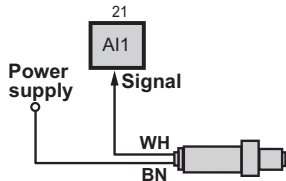

● EWPA 0...5 V ratiometric

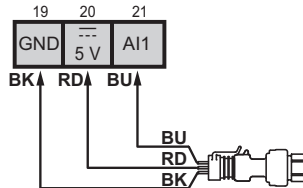

● 0...5 V ratiometric

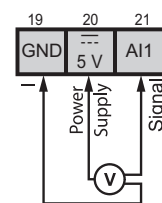

Fig. 10. TM171VEVA2 wiring diagram

TM171VEV•• - TM171DLED CONNECTION

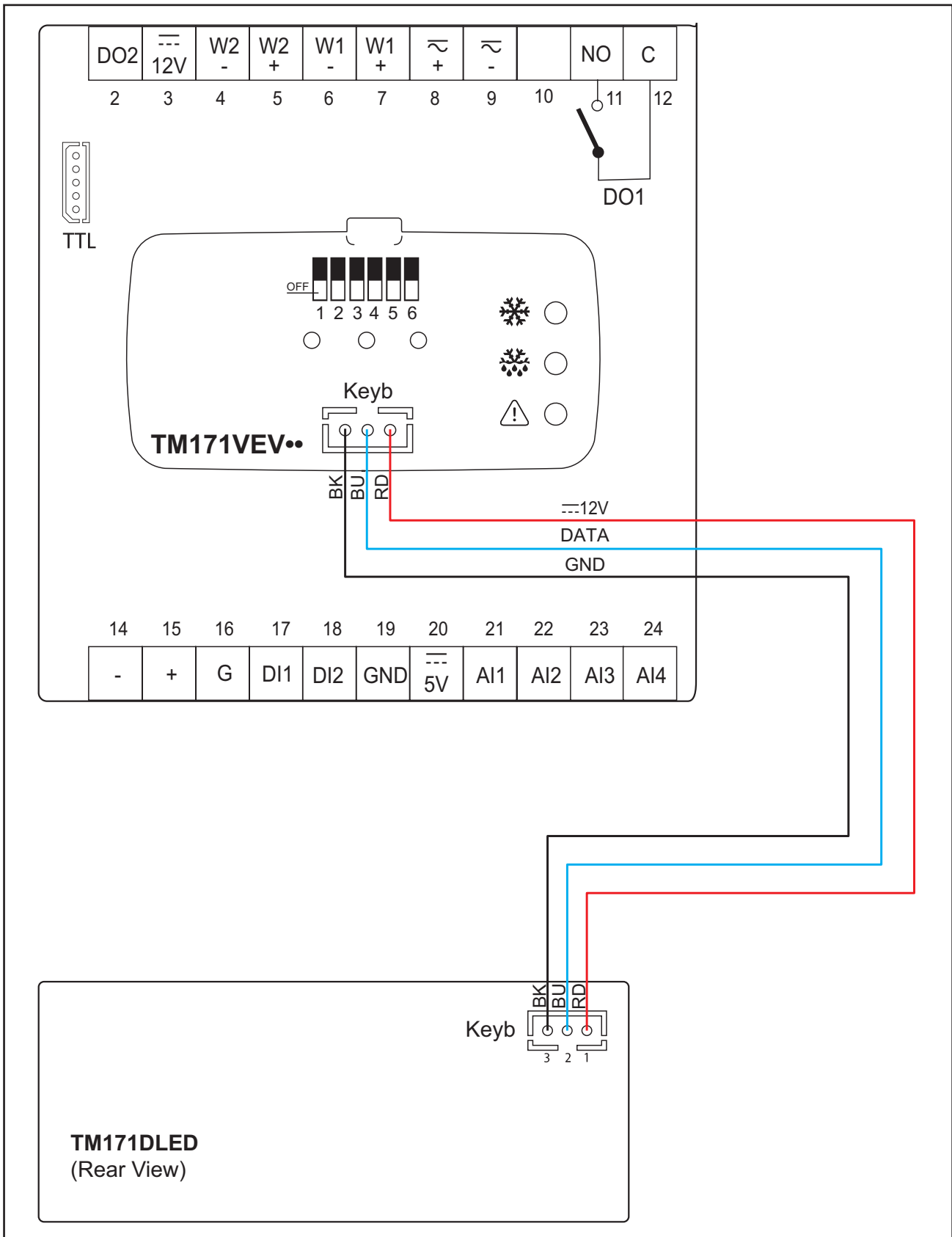
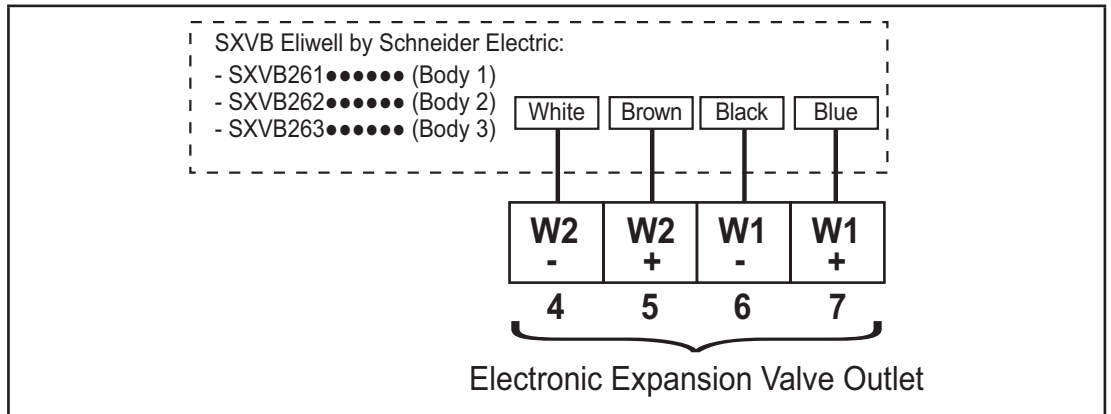

Fig. 11. TM171VEV•• - TM171DLED connection diagram

VALVE CONNECTION

Below is the connection diagram of **COMPATIBLE** valves (refer to 'RANGE' on page 11):



Connection diagram of compatible valves

NOTE: The connection diagram depicted below are presented in accordance with the technical documentation of the respective manufacturers listed in the boxes. The manufacturers specifications may change without notice.

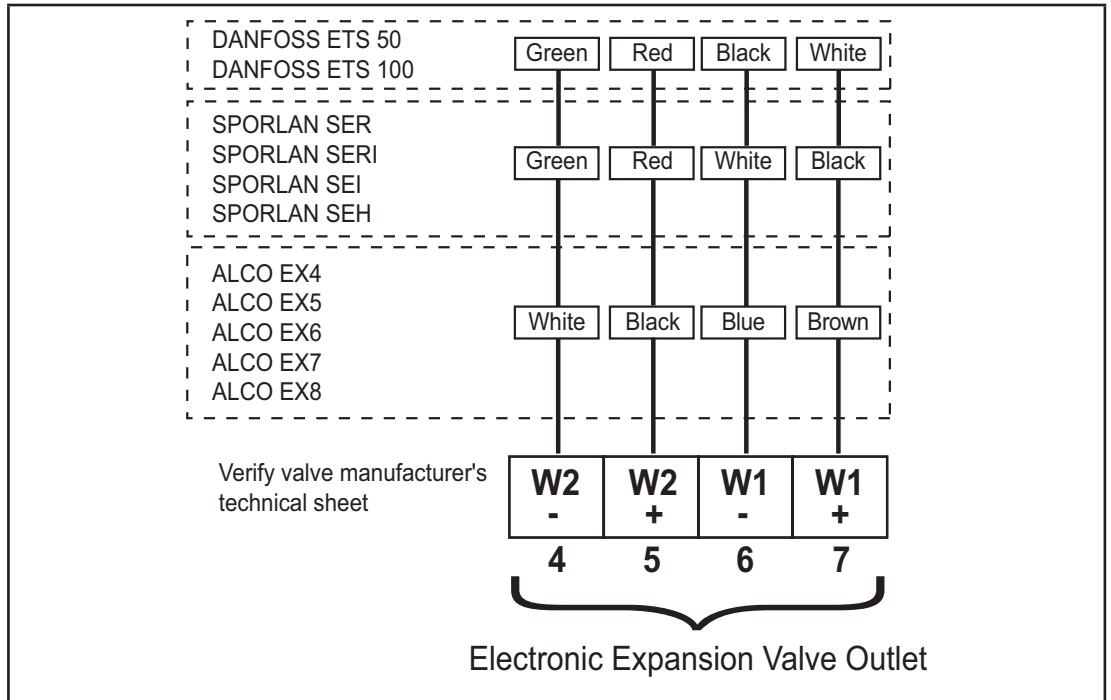

Producer	Valve	Reference document
DANFOSS	models ETS 50 / ETS 100	RK0YG302 dated 04/2007
SPORLAN	models SER / SERI / SEI / SEH	Bulletin 100-20-1 dated 05/2004
ALCO	models EX4 / EX5 / EX6 / EX7 / EX8	A3,5,008,5 dated 07/2004

Chapter 4

ENVIRONMENTAL CHARACTERISTICS

All components in the **TM171VEV••** devices meet the European Community (CE) requirements for open devices.

They must be installed in a cabinet or other designated place to suit the environmental conditions and minimise the risk of involuntary contact with high voltages. Use metal cabinets to improve the immunity of the **TM171VEV••** device to electromagnetic fields.

This device meets the CE requirements indicated in the table below.

WARNING

UNINTENDED EQUIPMENT OPERATION

Do not exceed any of the nominal values specified in the "General specifications" tables.

Failure to follow these instructions can result in death, serious injury, or equipment damage.

The application of incorrect current and voltage values to the analog inputs and outputs may damage the electronic circuits. Moreover, connecting a current input of a device to an analog input configured for voltage and vice-versa will also damage the electronic circuits.

NOTICE

INOPERABLE DEVICE

- Do not apply voltages over 11 V to the controllers analog inputs when the analog input is configured as a 0...5 V or 0...10 V input.
- Do not apply currents over 30 mA to the controller analog inputs when the analog input is configured as a 4...20 mA input.
- Ensure that the signal applied corresponds to the analog input configuration.

Failure to follow these instructions can result in equipment damage.

GENERAL SPECIFICATIONS

Feature	Description
The product complies with the following harmonised regulations:	EN 60730-1 / EN 60730-2-9
Construction of control:	Incorporated Control
Purpose of control:	Operating Control. Driver for expansion valve (non-safety related)
Method of mounting control:	DIN Rail or Panel mounting
Action type:	1.C
Pollution degré:	2
Insulating material class:	IIIa
Overvoltage category:	2
Rated impulse voltage:	2500 V
Software class:	A
Degree of protection provided by enclosure:	IP20 (Open type)
Environmental front panel rating	Open Type
Loads:	Refer to the section "Input/Output characteristics"

Feature	Description
Power supply:	24 Vac/dc ($\pm 10\%$), Class 2 Source
Power supply frequency:	50/60 Hz
Power draw (maximum):	35 VA / 25 W maximum
Ambient operating conditions:	Temperature: -10...65 °C (14...149 °F) Humidity: 10...90% RH (non-condensing)
Transportation and storage conditions:	Temperature: -20...85 °C (-4...185 °F) Humidity: 10...90% RH (non-condensing)
Maximum terminal temperature for internal conductors:	105 °C (221 °F)
Classification of control according to protection against electric shock:	Class II control intended for use in Class I equipment
Operating time:	Long period (IEC EN 60730 / UL 60730)
Power supply fuse	Fuse type T 3.15 A

MECHANICAL CHARACTERISTICS

The mechanical characteristics of the **TM171VEV** are:

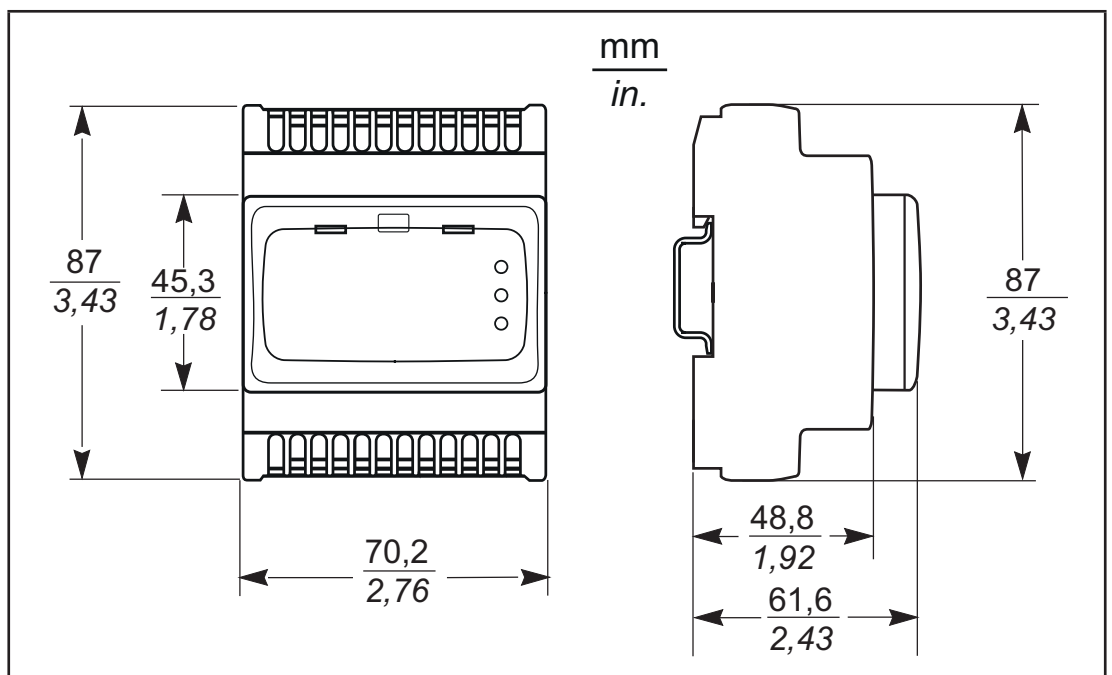

CHARACTERISTICS

The characteristics of the inputs on the **TM171VEV** are as follows:

Feature	Description	TM171VEM4	TM171VED4	TM171VEA2
Display:	3 digits + sign			
Measurement range:	NTC: -50.0...99.9 °C (-58.0...211.8 °F)	-	-	-
	NTC extended: -40.0...150 °C (-40.0...302 °F)			
	Pt1000: -50.0...99.9 °C (-58.0...211.8 °F)			
Full scale precision:	1%			
Resolution:	Temperature: 0.1 °C (0.1°F) Current-Voltage: 0.1 bar (1.45 psi)			
Analog Inputs:	AI1: 1 configurable analog input (*)	YES	YES	YES
	AI2: 1 configurable analog input (*)	YES	YES	NO
	AI3: 1 configurable analog input (*)	YES	YES	NO
	AI4: 1 configurable analog input (*) (*) See "Features of analog inputs" table.	YES	YES	NO
Digital inputs:	DI1: 1 voltage-free digital input; closure current for ground: 0.5 mA	YES	YES	NO
	DI2: 1 voltage-free digital input; closure current for ground: 0.5 mA	YES	YES	NO
Digital output:	DO1: 1 high voltage digital output (SPST relay): NO 3 A resistive 120/250 Vac (1.4 FLA - 7.5 LRA) 240 Vac	YES	YES	YES
OC (Open Collector) Output:	DO2: 1 multifunctional output: Maximum current = 100 mA Maximum voltage = 12 Vdc	YES	YES	NO
Electronic Expansion Valve output	W1+W1- / W2+W2- : 24 Vdc , 0.8 A	YES	YES	YES

ANALOG INPUTS CHARACTERISTICS

	NTC*	NTC extended*	Pt1000*	4...20 mA	0...10 V	0...5 V
AI1	YES	YES	YES	YES	YES	YES
AI2	YES	YES	YES	YES	YES	YES
AI3	YES	YES	YES	NO	NO	NO
AI4	YES	YES	YES	NO	NO	NO
Impedance	-	-	-	100 Ω	21 kΩ	110 kΩ
NTC: NTC 103AT-2 (10 kΩ at 25 °C / 77 °F), BETA value 3435 NTC extended: NTC 103AP-2 (10 kΩ at 25 °C / 77 °F), BETA value 3435 (*) probes not included - contact your local Schneider Electric representative.						

NOTICE

INOPERABLE EQUIPMENT

Do not apply external power supply to the dry contact digital inputs.

Failure to follow these instructions can result in equipment damage.

SERIALS



Serial	Description	Notes
TTL	1 TTL serial	Connection between the controller and the accessory for rapid programming M171 Optimized Programming stick (TM171AMFK). Connection to the Personal Computer via M171 Optimized Programming cable (TM171ADMI).
RS-485	1 opto-isolated RS-485 serial port	(TM171VEVM4 only) If the controller is connected at the end of the RS-485 communication line, apply a 120 Ω terminal resistor between the "+" and "-" line on the RS-485.
KEYB	1 serial for connection to terminal	3-way JST connector for connection to M171 Optimized Display LED 32x74 terminal (TM171DLED).

For more information refer to '**SERIAL CONNECTIONS**' on page 23.

Extreme care must be taken when connecting the serial lines. Incorrect wiring may cause the equipment to become inoperable.

POWER SUPPLY

The device can be powered at a voltage of 24 Vac (±10%) 50/60 Hz or 24 Vdc.

  DANGER
AN EARTH LOOP CAUSES ELECTRICAL SHOCK AND/OR DAMAGE TO THE EQUIPMENT
<ul style="list-style-type: none"> Do not connect the 0 V power supply/transformer connection supplying this equipment to any external ground (earth) connection. Do not connect any 0 V or ground (earth) of the sensors and actuators connected to this equipment to any external ground connection. If necessary, use separate power supplies/transformers to power sensors or actuators isolated from this equipment.
Failure to follow these instructions will result in death or serious injury.

If the specified voltage field is not maintained, or if the actual separation of the SELV circuit connected to the equipment in question is compromised, the equipment may operate unintentionally or become inoperable.

 WARNING
POTENTIAL OF SUPERHEAT AND FIRE
<ul style="list-style-type: none"> Do not connect the equipment directly to line voltage. Use only isolating SELV, Class 2 power supplies/transformers to supply power to the equipment.
Failure to follow these instructions can result in death, serious injury, or equipment damage.

The device must be connected to an appropriate power supply/transformer with the following characteristics:

Primary voltage	Depending on requirements of the individual device and/or country of installation
Secondary voltage	24 Vac/dc (±10 %), Class 2 Source
Power supply frequency	50/60 Hz
Power supply	35 VA

Chapter 5

USER INTERFACE



INTRODUCTION

The interface, comprising the front cover of the controller, allows you to perform the operations needed to use the device.



TM171VEV••

On the front of the **TM171VEV••** Valve driver there are 3 LEDs which indicate the valve state. Inside the door there are 3 more LEDs used to upload/download parameters and/or applications ('Chapter 9' on page 57)

	LED	Colour	On	Flashing	Off
	EEV	Green	<ul style="list-style-type: none"> Valve regulation (TM171VEV•4) Valve opened (TM171VEVA2) 	Valve closed (no control in progress) Setpoint reached	Power outage
	Defrost	Yellow	<ul style="list-style-type: none"> Defrosting on Valve closed (no control in progress) (TM171VEV•4) Reserved (TM171VEVA2) 	No serial connection	No Defrost
	Alarm	Red	-	<ul style="list-style-type: none"> Alarm present No serial connection 	No Alarm

TM171DLED

You can configure the **TM171VEV** Valve driver using the **TM171DLED** terminal.
The values shown on the **TM171DLED** terminal can have at most 4 digits or 3 digits plus a sign.

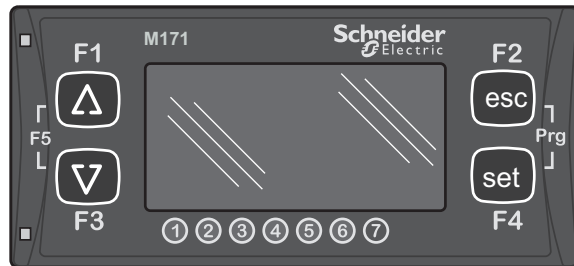

KEYS





	Key	Press and release	Press and hold
	UP	<ul style="list-style-type: none"> Rapid superheat setpoint modification* Increase value / Move to next label 	F1 : NOT USED
	DOWN	<ul style="list-style-type: none"> Rapid superheat setpoint modification* Decrease value / Move to previous label 	F3 : NOT USED
	esc	<ul style="list-style-type: none"> Exit without saving new settings Go back to previous level 	F2 : NOT USED
	set	<ul style="list-style-type: none"> Confirm value / exit and save new settings Move to next level Go to the Status Menu (open folder, subfolder, parameter, value) 	F4 see 'MAIN DISPLAY' on page 39
	esc+set	Opens the Programming Menu	Prg see 'MAIN DISPLAY' on page 39
	UP+DOWN	Alarm acknowledgement	F5 : NOT USED

* Also modifiable from parameter dE31 and dE32.

ICONS

The display shows the value/resource set for the “main display”.

If there are multiple alarms, they will be displayed successively in rotation on the display.

No.	Colour	Description	Notes
	Red	Menu (ABC)	-
	Red	Display pressure (bar)	Values are in relative bars. If the value is in psi, the icon does not appear.
	Red	Display temperature (°C)	If the value is in °F the icon does not appear.
	Red	Alarm	-

ACCESS TO FOLDERS - MENU STRUCTURE

Menus provide access to folders. Access to the menus is defined by the keys on the front cover as shown in '**TM171DLED**' on page 37.

There are 2 menus:

- “Status” menu: see '**STATUS MENU**' on page 40
- “Programming” menu: see '**PROGRAMMING MENU**' on page 43

In the “Programming” menu there are 3 folders:

- “Parameters” menu (PAr folder): see '**Chapter 12**' on page 66
- “**TM171AMFK**” menu (FnC folder): see '**Chapter 9**' on page 57
- “PASS” password: see '**Chapter 12**' on page 66

MAIN DISPLAY

The Main Display is what the display presents by default.

The **TM171VEV** Main Display can be customized to suit personal requirements.

Choose the required display from the “disp” menu.

To access the “disp” menu press and hold down the **set** key for more than 3 seconds.

The Main Display can be selected from the following:

Label	Description*	Display value	Display value if probe is inoperable (backup)
drE1	Superheat temperature	dAi3 Probe superheat	dAi4 Backup probe superheat
drE2	Saturation temperature of refrigerant	dAi1 Saturation probe	dAi2 Backup saturation probe
drE3	Superheat temperature Backup probe	dAi4	--- (three dashes)
drE4	Saturation temperature of the back-up Probe refrigerant	dAi2	--- (three dashes)
drE5*	Superheat	Difference of drE1-drE2	NA
drE6	Refrigerant Pressure	dAi1 For configuring the probe as a saturation 4..20 mA or ratiometric probe	dAi2 : For configuring the probe as a backup saturation 4..20 mA or ratiometric probe Otherwise : --- (three dashes)
drE7	Valve opening percentage	value opening percentage value (0...100%)	--- (three dashes)

(*) Default.

- NOTES:**
- The analog inputs are factory-set.
 - Display shows temperature values rather than pressure. (see **INPUT/OUTPUT DISPLAY** on page 42).

A step by step illustration of how to proceed is provided below.

Display settings

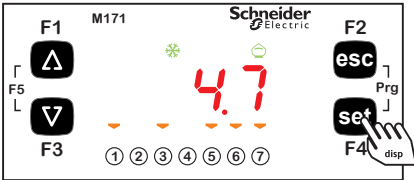

To open the “disp” menu to modify the main display setup, press and hold the **set** key for at least 3 seconds.

↓

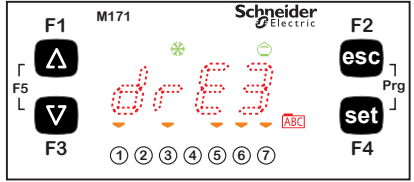

This will open the flashing menu on the previous display (in this case **drE3**).

↓

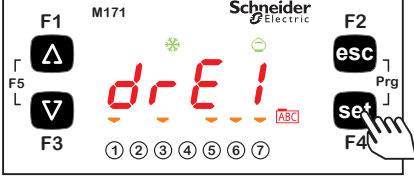

To modify the display, scroll the menu using the **▲** and **▼** keys and press the **set** key to confirm. When you have decided the type of display (e.g. **drE1**), press **set** to confirm. You will be automatically returned to the main display set.

STATUS MENU



The resources value can be viewed in the status menu.

The setpoint can be viewed and modified.

Resources can be present / not present depending on the model (for example **DO2** is not present on **TM171VEVA2**).

Label	Setpoint				Description	Edit
rE	rE1	rE2	...	rE7	Main Display	NO For the programming see: 'SETPOINT PROGRAMMING' on page 40
Ai	AI1	AI2	AI3	AI4	Analog inputs	No
of	DI1	DI2	-	-	Digital inputs	No
dO	DO1	DO2	-	-	Digital outputs	No
AL	Er01	Er02	...	Er15	Alarms	No
SP	SP1	SP2	SP3	SP4	Setpoint	Yes (not SP4)

SETPOINT PROGRAMMING

Setpoint	Description	Settable by parameter	Notes
SP1	minimum superheat setpoint	dE32	Rapid modify of SP1 using  and  keys.
SP2	maximum superheat setpoint	dE31	-
SP3	MOP setpoint	dE52	Expressed in temperature units.
SP4	dynamic superheat setpoint	Display only. Cannot be edited. Calculated dynamically.	<ul style="list-style-type: none"> If dE30=0: SP4 = dE32; If dE30=1: dE32 ≤ SP4 ≤ dE31. When the dynamic setpoint is active, the SP4 setpoint starts with dE31 value (after a black-out or at the end of defrost for the time set by dE51). Afterwards, the device will decrease the SP4 value attempting to reach the dE32 value.

A step by step illustration of how to proceed is provided below.

Setpoint Programming

To access the Status Menu, press and release the **set** key
Label rE appears on the display.
(Use the **▲** and **▼** keys to scroll the other labels until you find the SP label)

Press the **set** key to view the first setpoint SP1.

Press the **set** key again to view the value of SP1
(press the **▲** and **▼** keys to view the other setpoints).
To modify the display use the **▲** and **▼** keys and press the **set** key to confirm.
Press **set** to confirm. You will be automatically returned to the main display.

Rapid programming of setpoint SP1

To modify the setpoint use the **▲** and **▼** keys.

The current setpoint value will appear on the display.
To modify the value use the **▲** and **▼** keys and press the **set** key to confirm.

Press **set** to confirm.
You will be automatically returned to the main display.

INPUT/OUTPUT DISPLAY

The procedure to display the analog inputs is given below.
The procedure is the same for other Inputs/Outputs*.

Input/output display

To access the Status Menu, press and release the **set** key. Label rE appears on the display.
(Use the **▲** and **▼** keys to scroll the other labels until you reach **dAi**).

Press the **set** key to view the first analog value (**dAi1** in this case).

Press the **set** key again to view the value of **dAi1**. The °C icon flashes to indicate that the value shown is in degrees centigrade.
Press the **esc** key repeatedly to go back to the main display.

* for Digital inputs the value is:
0 = input not active (input circuit opened)
1 = input active (input circuit closed).

ALARM DISPLAY (AL)

A step by step illustration of how to proceed is provided below.

Alarm Display

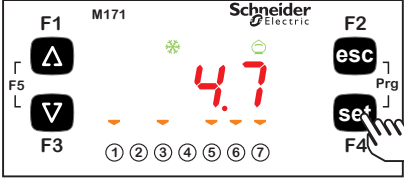

↓

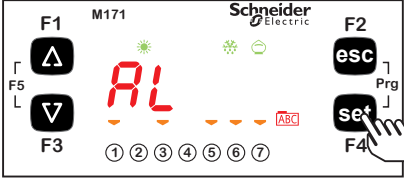

↓

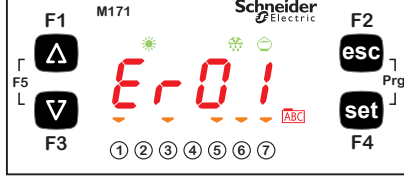

To access the Status Menu, press and release the **set** key
Label rE appears on the display.
(Use the **▲** and **▼** keys to browse the other labels until you find the AL label).

Press the **set** key to view the label of the first active alarm (if active).

In this case, the first alarm is Er01.
Scroll using the **▲** and **▼** keys to find other active alarms.

NOTE: The menu is not cyclical.

For example, if the active alarms are Er01 and Er02, the display will show: **Er01 ->Er02<Er01**

NOTE: -> UP, <- DOWN

Press the **esc** key repeatedly to go back to the main display.

PROGRAMMING MENU

Programming menu	Label			
Parameter folder	PAr			
Parameters sub-folders	dL	dF	dE	Ui
Functions Folder	FnC	-		
Password folder	PASS			

PARAMETERS (PAR)

A step by step illustration of how to proceed is provided below.

Modifying a parameter

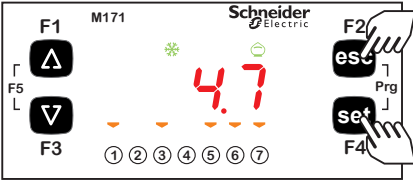

To view the Parameters Menu (PAR), press **esc** and **set** simultaneously.



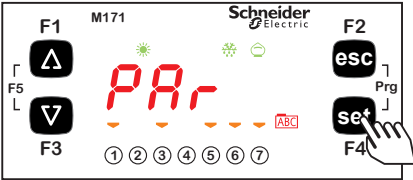

The Parameters Menu PAR contains all controller folders. Press the **set** key to view the folders.



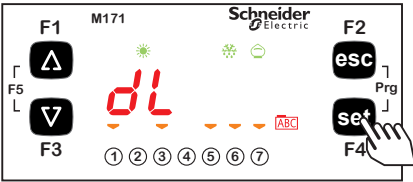

The first folder, the controller shows is the dL configuration folder. Press the **set** key again to modify the dL parameters.



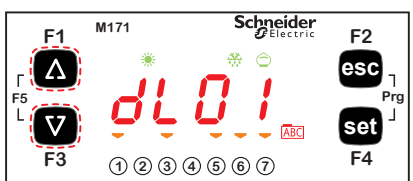

The controller will show parameter **dL00**. Press the **▲** key to scroll through the various parameters or move to the next parameter (**dL01** in this example) or the **▼** key to go back to the previous parameter (**dL91** in this case)

dL00 -> dL01 -> dL02 -> ... -> dL91 -> dL00
dL91 <- dL00 <- dL01 <- ... <- dL90 <- dL91

NOTE: -> UP, <- DOWN



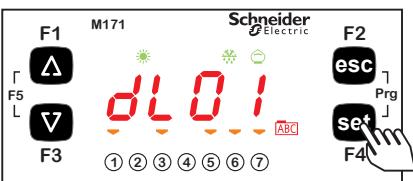

To view the parameter value (**dL01** in the example), press the **set** key.



For parameter **dL01**, the value shown will be 2.
To modify the parameter value, press the **▲** and **▼** keys.

Having selected a value, press the **set** key.**
To exit this display and return to the previous level, press the **esc** key.

** Press the **set** key to confirm the modified value; press the **esc** key to returns to the previous level without saving the new value entered.

MULTI FUNCTION KEY (PAr/FnC)

See 'Chapter 9' on page 57.

SETTING THE PASSWORD (PAr/PASS)

Access the PASS folder (basic view by pressing **esc** and **set** and search the folder using the **▲** and **▼** keys); set the PASS value to have access to the parameters visible for that password.

Setting the password

To view the PASS folder in the main display, press **esc** and **set** simultaneously.

The menu showing the list of folders will be displayed. Use the **▲** and **▼** keys to find the PASS folder.

Press the **set** key to enter the PASS folder. Set the password (installer or manufacturer), press **set** and exit. Enter to modify a value (see 'Chapter 12' on page 66).

Chapter 6

PHYSICAL I/O CONFIGURATION

OVERVIEW

Applying incorrect current or voltage levels on analog inputs and outputs could damage the electronic circuitry. Further, connecting a current input device to an analog input configured for voltage, and vice-versa, will likewise damage the electronic circuitry.

NOTICE

INOPERABLE DEVICE

- Do not apply voltages over 11 Vdc to the analog inputs of the controller or Input/Output expansion module when analog input is configured as 0...10 Vdc input.
- Do not apply currents above 30 mA to the analog inputs of the controller or Input/Output expansion module when analog input is configured as 4...20 mA input.
- Do not mismatch applied signal with analog input configuration.

Failure to follow these instructions can result in equipment damage.

ANALOG INPUTS

There are a total of 4 Analog Inputs, referred to below as AI1...AI4.

Using the parameters, a resource (probe, digital input, voltage/current signal) can be configured for each type of input. See the following table.

PAR.	Description	0	1	2	3*	4*	5*	6
dL00	Type of analog input AI1	Probe not configured	NTC	Pt1000	4...20 mA	Ratiometric 0...5 V	0...10 V	NTC extended
dL01	Type of analog input AI2	Probe not configured	NTC	Pt1000	4...20 mA	Ratiometric 0...5 V	0...10 V	NTC extended
dL02	Type of analog input AI3	Probe not configured	NTC	Pt1000	-	-	-	NTC extended
dL03	Type of analog input AI4	Probe not configured	NTC	Pt1000	-	-	-	NTC extended

* If dL00/dL01 = 3, 4 or 5, the value read by the probe is automatically converted into drE2 value.

Analog input	Parameter	Range	Description
AI1	dL10	dL11...999.9	Analog input AI1 fullscale value
AI1	dL11	-14.5...dL10	Analog input AI1 start of scale value
AI2	dL12	dL13...999.9	Analog input AI2 fullscale value
AI2	dL13	-14.5...dL12	Analog input AI2 start of scale value

The values read by analog inputs can be modified using the parameters dL20...dL23

PAR.	Description	Unit of measure	Range
dL20	Analog input differential AI1	bar/psi -°C/°F	-12.0...12.0
dL21	Analog input differential AI2	bar/psi -°C/°F	-12.0...12.0
dL22	Analog input differential AI3	°C/°F	-12.0...12.0
dL23	Analog input differential AI4	°C/°F	-12.0...12.0

The analog inputs can be configured according to the following table.

PAR.	Function	Value	Description
dL30	Configuration of analog input AI1	0...5	<ul style="list-style-type: none"> • 0= disabled • 1= evaporator output (superheat) • 2= saturation
dL31	Configuration of analog input AI2	0...5	<ul style="list-style-type: none"> • 3= backup evaporator output (superheat) • 4= backup saturation • 5= valve opening direct control
dL32	Configuration of analog input AI3	0...4	<ul style="list-style-type: none"> • 0= disabled • 1= evaporator output (superheat) • 2= saturation
dL33	Configuration of analog input AI4	0...4	<ul style="list-style-type: none"> • 3= backup evaporator output (superheat) • 4= backup saturation

VALVE OPENING DIRECT CONTROL

If inputs **AI1** and **AI2** are configured in voltage or current, they are configurable for valve opening direct control as shown in the following table.

PAR.	Function	Value
dL00	Analog input type AI1	3-4-5
dL01	Analog input type AI2	3-4-5
dL30	Analog input configuration AI1	5
dL31	Analog input configuration AI2	5

In this case the input is converted linearly as a percentage, again using the parameters:

PAR.	Function	Range
dL10	Analog input full scale value AI1	dL11...999.9
dL11	Analog input start of scale value AI1	-14.5...dL10
dL12	Analog input full scale value AI2	dL13...999.9
dL13	Analog input start of scale value AI2	-14.5...dL12

Set the the following values:

AI1:

- **dL10** to a value corresponding to a signal of 10 V or 20 mA.
- **dL11** to a value corresponding to a signal of 0 V or 4 mA.

AI2:

- **dL12** to a value corresponding to a signal of 10 V or 20 mA.
- **dL13** to a value corresponding to a signal of 0 V or 4 mA.

Valve opening percentage

- **AI1(AI2) < -5.0:** a valve opening percentage of 0% is controlled with override (reset, repeated until the signal is less than -5.0).
- **-5.0 < AI1 < 0.0:** valve opening percentage of 0% is controlled.
- **AI1(AI2) > 0.0:** valve opening percentage is equal to the AI1 value (AI2).

DIGITAL INPUTS

The Digital inputs DI1/DI2 can be configured as shown in the following table.

PAR.	Function	Value	Description	Notes
dL40	Configuration digital input DI1	-7...7	<ul style="list-style-type: none"> • 0 = digital input not configured • ±1 = ON/OFF adjustment • ±2 = defrost • ±3 = alarm • ±4 = system operating mode (only modes 0 and 1) 	<ul style="list-style-type: none"> • The positive values (+) indicate active for closed contact, the negative values (-) indicate active for open contact. • If configured (values ≠ 0) the digital inputs always have priority over any serial commands • dL40 = dL41 digital input DI1 has priority.
dL41	Configuration digital input DI2	-7...7	<ul style="list-style-type: none"> • ±5 = main serial communication protocol • ±6 = ON/OFF adjustment with delay (in OFF, TM171VEV forces the opening to 50% for 40 seconds) • ±7 = complete valve opening 	

DIGITAL OUTPUTS

The Digital outputs DO1/DO2 can be configured as shown in the following table.

- DO1: High voltage relay SPST digital output.
- DO2: Open collector output.

PAR.	Function	Value	Description	Notes
dL90	Configuration digital output DO1 (on relay)	-2...2	<ul style="list-style-type: none"> • 0 = output controlled from serial • ±1 = solenoid valve control • ±2 = alarm output 	<ul style="list-style-type: none"> • The positive values (+) indicate active for closed contact. • The negative values (-) indicate active for open contact.
dL91	Configuration digital output DO2 (Open Collector)	-2...2	<ul style="list-style-type: none"> • 0 = output controlled from serial • ±1 = solenoid valve control • ±2 = alarm output 	

DIP-SWITCH TABLE

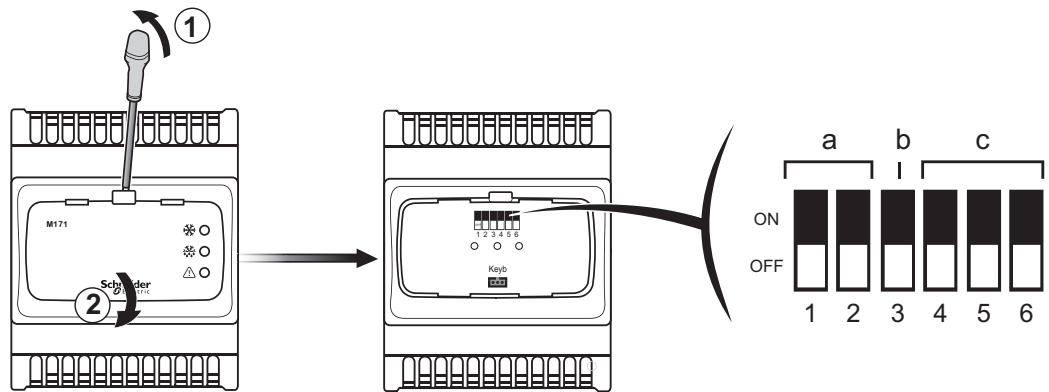

The 6 dip-switches are used for quick selection of refrigerant, network address and use of M171 Optimized Programming stick (**TM171AMFK**).

In this case set the dip-switches to configuration 7 according to the table below.

Function	Refrigerant	Selectors (dip-switches)					
		1	2	3	4	5	6
Refrigerant selection	R404A	-	-	-	OFF	OFF	OFF
	R448A	-	-	-	ON	OFF	OFF
	R410A	-	-	-	OFF	ON	OFF
	R134a	-	-	-	ON	ON	OFF
	R744 (CO ₂)	-	-	-	OFF	OFF	ON
	R407C	-	-	-	ON	OFF	ON
	R427A	-	-	-	OFF	ON	ON
	Set by parameter dE20 Default: R290	-	-	-	ON	ON	ON
Action		1	2	3	4	5	6
Upload/Download parameters from TM171AMFK	Upload TM171VEV** → TM171AMFK	ON	OFF	-	-	-	-
	Download: TM171AMFK → TM171VEV**	OFF	ON	-	-	-	-
TM171VEV** address		1	2	3	4	5	6
Select network address	0	-	-	OFF	-	-	-
	1	-	-	ON	-	-	-

NOTE: This operations can also be done from the M171 Optimized Display LED 32x74 terminal (**TM171DLED**) terminal by appropriately configuring the **dF** folder parameters. The refrigerant can be selected using parameter **dE20**.

Chapter 7

REGULATIONS

INTRODUCTION

TM171VEV regulates the superheat value at the evaporator output.

The control value is the percentage of valve opening according to the following parameters:

- **dE10**: Maximum valve opening percentage
- **dE13**: Operating time at maximum opening for alarm signal
- **dE14**: Minimum useful valve opening percentage
- **dE15**: Maximum useful valve opening percentage

If the regulator controls an output greater than or equal to **dE15**, the output is the value of **dE10**; ignored if **dE15** > **dE10**.

If the regulator controls an output less than or equal to **dE14**, the output is equal to 0.

If the regulator controls an output greater than or equal to **dE10**, for more than the time set in **dE13**, a maximum opening alarm **drE7** is generated to indicate an important system situation such as insufficient load, undersizing, etc.

To disable the signal, set **dE13** = 0.

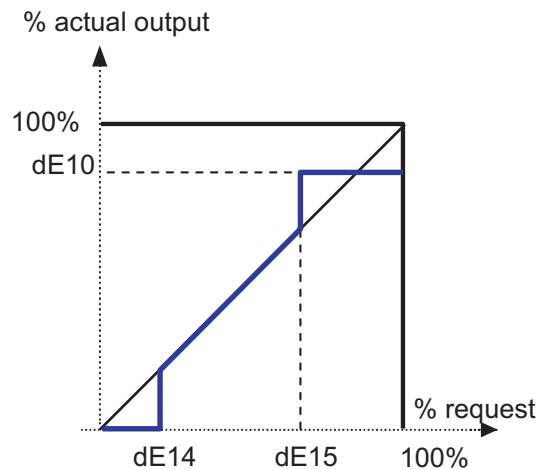

PID CONTROL ALGORITHM

TM171VEV calculates the process superheat value using the two analog inputs AI1 (Saturation probe) and AI3 (Superheat probe).

A PID regulator modulates the valve opening to make the superheat reach the setpoint **dE32**.

The algorithm is dynamic: the effective superheat value may not reach the setpoint or may temporarily fall below this value (Valid for **dE30** = 1 - Superheat recalculation enabled).

If liquefied refrigerant exits the evaporator, the setpoint **dE32** value must be increased.

THRESHOLD CONTROL ALGORITHM

To activate the dead zone for proportional part control algorithms set **dE25** = 1.

This algorithm is managed by the following dedicated parameters:

PAR.	Description	UM	Range	Default
dE26	Proportional control coefficient	°C/°F	0.1...999.9	50.0
dE27	Integral regulator gain	num	0...1999	10
dE28	Valve activation recalculation period	s x 0.2	1...1999	4
dE29	Dead zone for proportional part	°C/°F	0.1...999.9	1.0
dE66	Maximum valve opening variation compared to previous calculation period	%	0.1...100.0	3.0

Within the cut-in thresholds, **TM171VEV** acts only on the integral part.

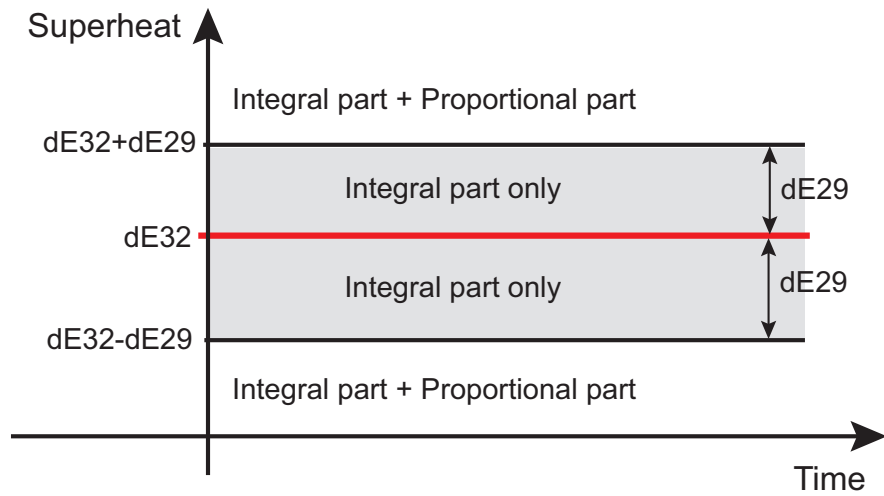

The proportional component is equal to 0% within the thresholds while it cuts in outside of these.

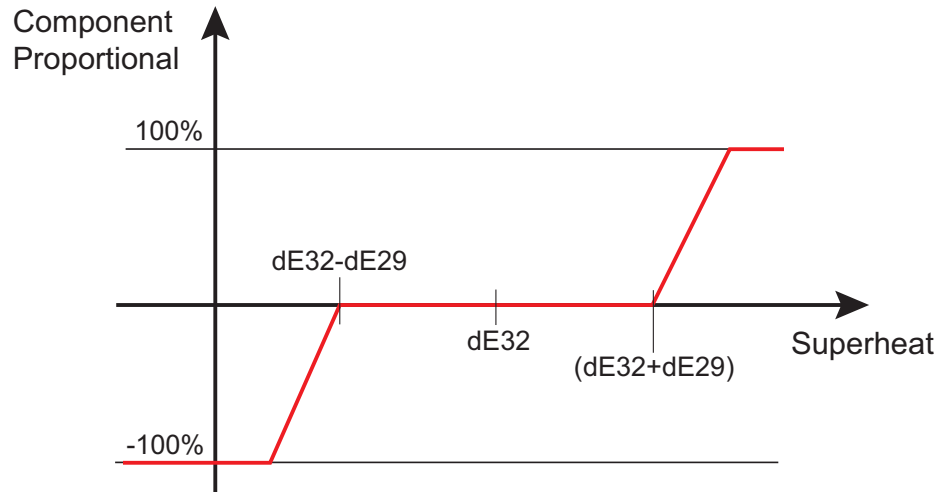

The list below defines the type and operational logic for the driver PID control. Verify and modify these parameters, if necessary, to customize the system operation.

The PID output value is recalculated according to the value established in **dE28**.

This algorithm is used to synchronize (and therefore limit) the speed by which the PID varies synchronizing it with the valve opening and closing speed. It is possible to limit the maximum valve opening/closing speed between two subsequent recalculations using parameter **dE66**.

Below a PID control tuning method is given as an example only, to be performed with a constant load:

1. Set a sufficiently high proportional band value;
2. Energize the device and verify the superheat progress:
 - a. If it approaches the setpoint **dE32** very slowly, increase the integral regulator gain value (**dE27**) and repeat the step;
 - b. If it goes far below the setpoint (**dE32**) and stays there for a significantly long time, reduce the integral regulator gain value (**dE27**) and repeat the step.
3. When the result of the previous step is sufficiently accurate, you can increase the system reactivity, reducing the proportional band via the proportional control coefficient (**dE26**).

NOTE: the weight of the integral component of the algorithm increases as the value of **dE27** increases. (This function is opposite to what happens with the standard PID algorithm, where the integral time increased reduces the weight of the integral part).

SUPERHEAT SETPOINT FROM REMOTE

This function is used to modify the superheat setpoint via Modbus by managing a temporary setpoint register. This setpoint value will be valid for the entire time in which the corresponding timeout is not equal to 0.

The management logic is as follows:

1. Enter a timeout value (in seconds) in the Modbus address of the:
TimeOut_Remote_Setp_Overheating.
2. Enter the superheat setpoint value in the Modbus address of the:
Remote_Setp_Overheating.
3. Periodically update the value set in point 2.

When the timeout has expired, the **TM171VEV••** driver will upload the new setpoint value (**dE32**).

PLANT TYPE (dE21)

The PID configuration parameters are loaded automatically by the device selecting the type of system defined by the parameter **dE21**.

MOP (Maximum Operating Pressure)

MOP control has a threshold set by the pressure setpoint **dE52**.

Above this threshold for more than the time defined by **dE53**, a MOP alarm is triggered (see '**Chapter 11**' on page 64):

- MOP control can be enabled using parameter **dE50**.
- MOP control can be disabled when the device is powered on or after a defrost condition for an amount of time equal to **dE51**. This allows the pressure to drop below a given level when the system is powered on.

MOP SETPOINT FROM REMOTE

This function is used to modify the MOP setpoint via Modbus by managing a temporary setpoint register. This setpoint value will be valid for the entire time in which the corresponding timeout is not equal to 0.

The management logic is as follows:

1. Enter a timeout value (in seconds) in the Modbus address of the:
TimeOut_Remote_Setp_MOP.
2. Enter the MOP setpoint value in the Modbus address of the:
Remote_Setp_MOP.
3. Periodically update the value set in point 2.

When the timeout has expired, the **TM171VEV**** driver will upload the new setpoint value.

TM171VEV** AS ACTUATOR FROM REMOTE

This function is used remotely; it is possible to use the driver as an actuator, sending the required opening percentage.

The management procedure is:

1. Enable the actuator mode flag by entering in the Modbus address
EEV_STTS_FORCE_OPEN_SET.
2. Set the required percentage, entering it in the Modbus address
Remote_Percentage.
3. Periodically update the timer value set in point 2.

The actuator management mode from remote can only be activated if:

- No digital input is configured as "100% open" (**DL40** ≠ ±7 and **DL41** ≠ ±7);
- Parameter **dF02** is not equal to 0.

The actuator management mode from remote is disabled automatically if:

- The actuator mode flag is disabled, setting value 0 in the Modbus address
EEV_STTS_FORCE_OPEN_SET.
- More than 60 seconds have passed since the receipt of the last Modbus command.

VALVE ACTIVATION WITH FIXED PERCENTAGE

When the device enables the superheat control, it is possible to force the value for a limited period of time to a fixed percentage value.

To set the period of time in which the valve runs with a fixed percentage, set parameter **dE49** (in seconds). The fixed percentage is defined by **dE11** parameter.

If **dE11** equals 0%, the device will force the valve to open to the previous percentage value.

STAND-ALONE

The **TM171VEV••** driver regulates autonomously using the analogue inputs connected.

The **TM171VEV••** driver status can be controlled via:

1. digital inputs (using models, **TM171VEVM4**, **TM171VEVD4**).
2. RS-485 serial connection (using model **TM171VEVM4**).

The **TM171VEV••** driver controls the electronic expansion valve and receives commands. For example “defrost” and “EEV ON-OFF” from:

1. digital inputs (see '**DIGITAL INPUTS**' on page 48).
2. RS-485 serial.

depending on the **df02** parameter.

The type of operation depends on the setting of parameter **df02**:

- if **df02 = 0**: digital input.
- if **df02 ≠ 0**: RS-485 serial.

If the Digital inputs are configured not equal to 0 they always have priority over the serial command independently of **df02** (see '**Chapter 6**' on page 46).

The Modbus protocol is selected using parameter **df00**.

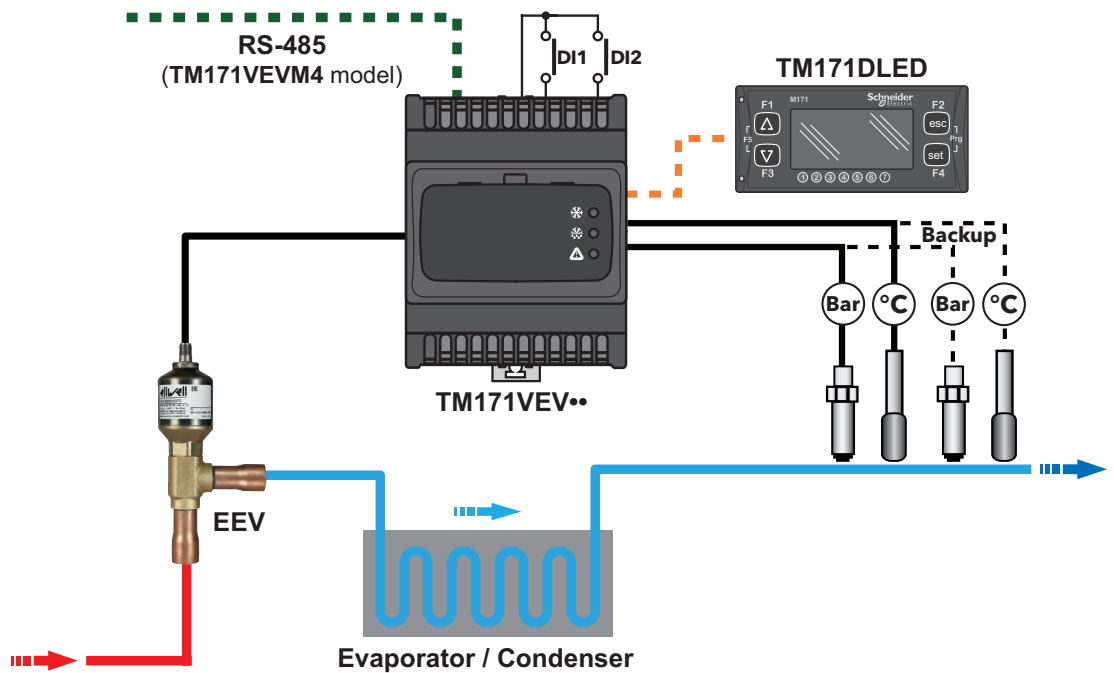

DIGITAL INPUT CONFIGURATION

Value dL40/dL41			Notes
±1	ON	Enable adjustment	<ul style="list-style-type: none"> if dE11 = 0: Forces the valve opening to the value used before the last OFF if dE11 ≠ 0: Forces the valve opening to value dE11 for a time period set in dE35
	OFF	Disable adjustment	Valve closing. (save the percentage in dE11).
±2	ON	Defrost in progress	Valve closing The configured digital input ±1 is ignored until the end of defrost. At the end of defrost: <ul style="list-style-type: none"> If dE12 ≠ 0: the valve is forced open to the defined value (dE12). Otherwise it will run according to dE11
	OFF	No defrost	-
±3	ON	Alarm active	Valve closing.
	OFF	Alarm not active	-
±4	ON	Enable adjustment	Control enabled with profile defined by: dE22 - Type of system operating mode 1.
	OFF	preset factory regulation	Control enabled with profile defined by: dE21 - Type of system operating mode 0.
±5	ON	Protocol setting for main serial communication	Modbus protocol with data parameters from: dF30, dF31, dF32.
	OFF		The communication protocol is set by dF00
±6	ON	Enable regulation	<ul style="list-style-type: none"> if dE11 = 0: Forces the valve opening to the value used before the last OFF if dE11 ≠ 0: Forces the valve opening to value dE11 for a period of time set in dE35
	OFF	Deactivate regulation	Forces the valve opening to value dE70 for a time period set in dE71 . Once delay dE71 has elapsed, the driver: <ul style="list-style-type: none"> closes the valve closes the solenoid valve (if the driver is so configured) deactivates the valve regulator
±7	ON	Valve opening to 100%	The valve opening is forced at 100% whatever the opening of the other regulators, unless the alarms force the valve to close.
	OFF	The valve control returns to the current regulator	The manual/automatic (bumpless) passage starts from a 100% valve opening.

RS-485 SERIAL CONTROL

To remotely control the driver, refer to '**RESOURCE TABLE**' on page 85.

It is also possible to enable operating modes 2 and 3 (parameters **dE23** and **dE24**) which are not available for Digital inputs.

Chapter 9

M171 OPTIMIZED PROGRAMMING STICK (TM171AMFK)

OVERVIEW

When connected to the TTL serial port, the M171 Optimized Programming stick (**TM171AMFK**) allows you to rapidly configure the device parameters (upload/download parameter map to or from one or more devices of the same type).

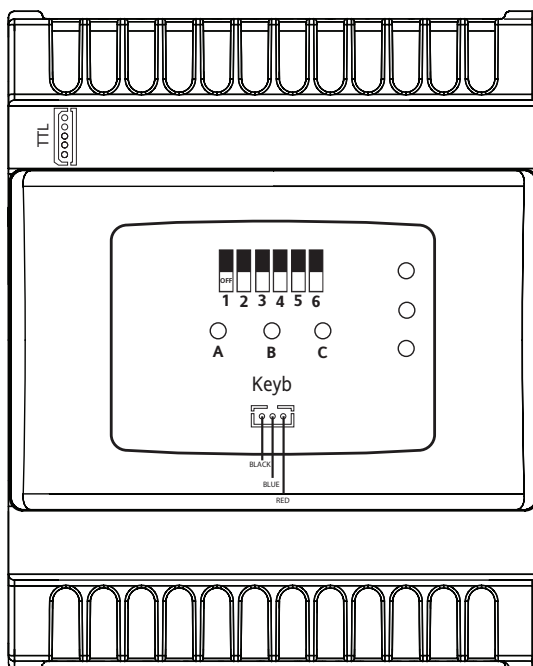

NOTE: To connect the **TM171AMFK** to the TTL serial port, use the yellow cable supplied.

The upload (label UL), download (label dL) and copy card formatting (label Fr) operations are performed as explained below:

UPLOAD (UL): Copy from the DEVICE to the **TM171AMFK**. By doing this, the programming parameters will be loaded from controller to the **TM171AMFK**.

DOWNLOAD (dL): Copy from the **TM171AMFK** to the DEVICE. By doing this, the programming parameters will be loaded from the **TM171AMFK** to the controller.

FORMAT* (Fr): Formatting the **TM171AMFK** consists of deleting its contents.
**This should be done prior to Uploading when used for the first time.*

There are two ways of using the **TM171AMFK**.

- Using the dip-switches (only Upload/Download)
- Via the **TM171DLED** terminal

DIP-SWITCH LEDS

The LEDS A/B/C located under the cover indicate the operating state.

LED	Colour	UPLOAD		
		Underway	Completed correctly	Not completed
A	Green	Flashing	On	On
B	Yellow	-	-	-
C	Green	-	-	Flashing
LED	Colour	DOWNLOAD:		
		Underway	Completed correctly	Not completed
A	Green	-	-	-
B	Yellow	Flashing	On	On
C	Green	-	-	Flashing

UPLOAD/DOWNLOAD VIA DIP-SWITCH

Proceed as follows:

1. insert the M171 Optimized Programming stick (**TM171AMFK**) in the appropriate connector with the instrument switched on
2. place the dip-switches 1 or 2 inside the door to "ON", as described in the following table
3. when the operation has been completed, remove the M171 Optimized Programming stick (**TM171AMFK**)
4. return the dip-switch to "OFF"

DIP ->		1	2	3	4	5	6
Upload/Download parameters from TM171AMFK	Upload	ON	OFF	-	-	-	-
	Download	OFF	ON	-	-	-	-

UPLOAD/DOWNLOAD VIA TM171DLED

A step by step illustration of how to proceed is provided below:

Upload/Download/Format

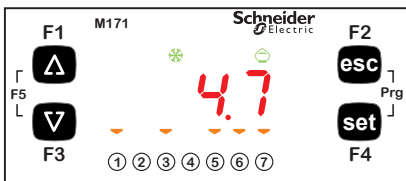

↓

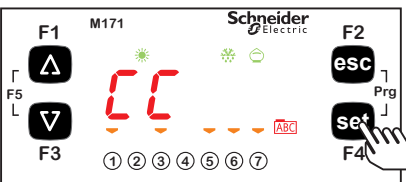

↓

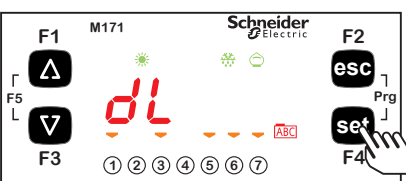

↓

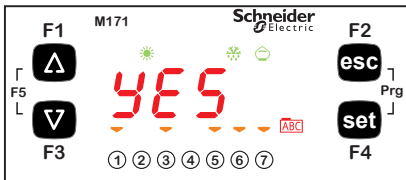

↓

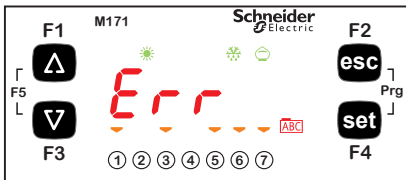

From the main display press **esc** and **set** simultaneously. The label 'PAr' will appear. Use **▲** and **▼** to view the label "FnC". Press **set**. The CC label will appear.

Press **set** to access the functions.

Scroll **▲** and **▼** to search for the function you want:

- UL for upload;
- dL for download;
- Fr for format.

Press **set** to select the upload or download operation. (dL- download in the example). Wait until the operation is performed.

If the operation is successful, the display shows "YES".

If the operation is NOT successful, the display shows "Err".

DOWNLOAD FROM M171 OPTIMIZED PROGRAMMING STICK (TM171AMFK)

FIRMWARE DOWNLOAD

Ensure the device is not powered before connecting the key. At start up, if a compatible firmware is loaded into the **TM171AMFK**, the new firmware is downloaded into the device.

This happens as follows:

- firmware verification/update (**TM171AMFK** LED flashing)
- termination with successful programming (**TM171AMFK** LED on fixed)
- device de-energized





NOTE: if there is no compatible firmware in the **TM171AMFK** no firmware can be downloaded and the LED stays OFF.

If the procedure is not completed successfully, the **TM171AMFK** LED is flashing.

DOWNLOAD FROM RESET

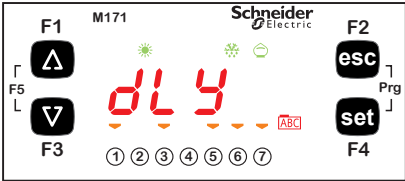
Connect the **TM171AMFK** with the device de-energized. At start up, if there is a compatible parameter map is loaded into the **TM171AMFK**, the programming parameters are loaded into the device.

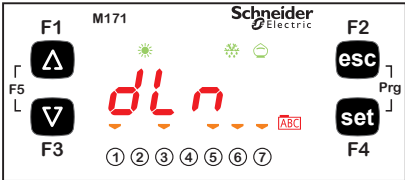
Download from reset

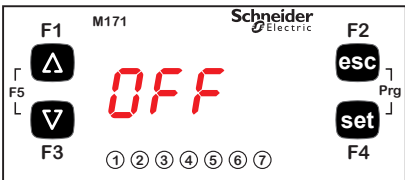
	<p>Example A after the lamp test, the display shows dLY. If the procedure was completed successfully.</p>
	
	<p>Example B after the lamp test, the display shows dLn Completion of the procedure was unsuccessful (°).</p>
	
	<p>In both cases, the instrument will be de-energized locally (OFF appears on the display). Press ▼ (see 'DIGITAL INPUTS' on page 48) and the controller will operate:</p> <ul style="list-style-type: none">• with the new map Example A;• with the previous map Example B. <p>Remove the TM171AMFK on completion.</p>

NOTES:

- If the **TM171AMFK** is loaded with both a compatible firmware and a compatible parameter map, the firmware is downloaded first and then (after the device has been power cycled manually) the parameter map.
- The formatting function is ONLY REQUIRED FOR UPLOADING.
 - to use the **TM171AMFK** for the first time
 - to use the **TM171AMFK** with models that are not compatible

Formatting **CANNOT** be undone.

- After the download operation, the valve driver will work with the newly loaded parameters map/firmware
- Remove the key on completion of the operation

(°) If the string Err / dLn (download from reset) appears:

- verify that the key is connected to the device
- verify the **TM171AMFK** - **TM171VEV** connection (TTL cable)
- verify that the **TM171AMFK** is compatible with the device
- contact the Schneider Electric Technical Support

Chapter 10

SUPERVISION

TTL and RS-485 serial ports can be used to configure the device, parameters, states and variables with Modbus via the Modbus protocol.

CONFIGURATION WITH MODBUS RTU

Modbus is a master/slave protocol for communication between devices connected in a network.

Modbus devices communicate using a master-slave technique in which only one device (master) can send messages. The other devices in the network (slave) respond, returning the data requested by the master or executing the action contained in the message sent. A slave is a device connected to a network that processes information and sends the results to the master using the Modbus protocol.

The master device can send messages to individual slaves or to the entire network (broadcast) whilst slaves can only respond individually to the master.

The Modbus standard used by Schneider Electric employs the RTU code for data transmission.

DATA FORMAT (RTU)

The coding model used defines the structure of messages transmitted on the network and the way in which this information is deciphered. The coding type is usually chosen according to specific parameters (baud rate, parity, etc.)*.

Some devices also support only certain coding models. However this must be the same for all devices connected to a modbus network.

The protocol uses the RTU binary method with bytes configured as follows:

- **8 bit** for data
- **1 bit** for parity
- **1 or 2 bit** for stop (non configurable).

* *The values can be set in parameters **dF30**, **dF31** and **dF32**.*

Parameter setting allows the configuration of the device.

The parameters can be modified via:

- M171 Optimized Display LED 32x74 terminal (**TM171DLED**)
- M171 Optimized Programming stick (**TM171AMFK**)
- M171 Optimized Programming cable (**TM171ADMI**): Sending data via Modbus protocol directly to an individual controller or broadcasting it to all network devices using the address 0

Refer to the following connection diagram when using Modbus.

Modbus commands available and data areas

Modbus command	Command description	
3	Read multiple registers	
16	Write multiple registers	
43	0	Manufacturer ID
	1	Model ID
	2	Instrument ID

DEVICE ADDRESS CONFIGURATION

The address of a device (Device Number) in a ModBus message is defined in parameter **dF30**. See '**PARAMETERS (PAr)**' on page 66.

The address 0 is used for broadcast messages that all slaves recognize. Slaves do not respond to broadcast messages.

PARAMETER ADDRESS CONFIGURATION

For the list of addresses, refer to '**PARAMETERS/ VISIBILITY**' on page 68.

CONFIGURATION OF VARIABLE ADDRESSES/STATES

For the list of addresses, refer to '**RESOURCE TABLE**' on page 85.

Chapter 11

ALARMS

TM171VEV** is able to perform diagnostics of the system and report any operating issues with specific alarms and displaying the error code.

The alarm condition is always reported by the LED near the alarm icon and the enabling of the output on the relay, if appropriately configured.

The probe error is shown directly on the M171 Optimized Display LED 32x74 terminal (**TM171DLED**).

ALARMS TABLE

Label	Description/Cause*	Effect	Reset	Solution
Er01	Probe Ai1 in error • Measured values are outside operating range. • Probe inoperable/shortcircuited/ open.	If dL30 = 0...4: • Only reported if it does not involve an alarm Er05 or Er06 (see below) • Otherwise as described for Er05 or Er06 (see below). If dL30 = 5: • Valve closed.	A	• Verify the probe wiring. • Replace probe. • When error has been removed, regulation continues as normal.
Er02	Probe Ai2 in error • Measured values are outside operating range. • Probe inoperable/shortcircuited/ open.	If dL31 = 0...4: • Only reported if it does not involve an alarm Er05 or Er06 (see below) • Otherwise as described for Er05 or Er06 (see below). If dL31 = 5: • Valve closed.	A	Same as Er01 .
Er03	Probe Ai3 in error • Measured values are outside operating range. • Probe inoperable/shortcircuited/ open.	• Only reported if it does not involve an alarm Er05 or Er06 (see below) • Otherwise as described for Er05 or Er06 (see below).	A	Same as Er01 .
Er04	Probe Ai4 in error • Measured values are outside operating range. • Probe inoperable/shortcircuited/ open.	• Only reported if it does not involve an alarm Er05 or Er06 (see below) • Otherwise as described for Er05 or Er06 (see below).	A	Same as Er01 .
Er05	Evaporator output probe error. The probes AI3 and AI4 are inoperable.	% valve opening (dE16).	A	Same as Er01 .
Er06	Saturation output error. The probes AI1 and AI2 are inoperable.	• Example dE50=0 % valve opening (dE16). • Example dE50=1 Valve closed.	A	Same as Er01 .
Er07	MOP alarm. Saturation temperature > MOP setpoint (dE52) for longer than dE53 .	Valid only if dE50 = 1. Valve closed.	A	Wait for saturation temperature to return < dE52 .
Er08	% maximum valve opening drE7 ≥ dE10 for longer than dE13 .	Report only.	A	Wait for return % of maximum valve opening drE7 < dE10 .

Label	Description/Cause*	Effect	Reset	Solution
Er09	External alarm. Activation of digital input configured as external alarm. See parameters dL40/dL41=±3.	Valve closed.	A	Deactivation of digital input configured as external alarm.
Er10	NO link alarm. Serial communication inoperable. (dF02=1, 2)	Valve closed.	A	Restore communication.
Er11	Motor protection alarm. Excessive current absorption.	Valve closed.	A	<ul style="list-style-type: none"> • Verify motor phases. • Verify motor connection.
Er12	Motor protection alarm. Coil winding 1 disconnected.	Valve closed.	A	<ul style="list-style-type: none"> • Verify winding 1 connection (terminals 6-7). • Verify correct parameter settings dE01...dE09, dE80.
Er13	Motor protection alarm. Coil winding 1 short circuit.	Valve closed.	A	<ul style="list-style-type: none"> • Verify winding 1 connection (terminals 6-7). • Verify correct parameter settings dE01...dE09, dE80.
Er14	Motor protection alarm. Coil winding 2 disconnected.	Valve closed.	A	<ul style="list-style-type: none"> • Verify winding 2 connection (terminals 4-5). • Verify correct parameter settings dE01...dE09, dE80.
Er15	Motor protection alarm. Coil winding 2 short-circuited.	Valve closed.	A	<ul style="list-style-type: none"> • Verify winding 2 connection (terminals 4-5). • Verify correct parameter settings dE01...dE09, dE80.

Reset: A = automatic reset. If the cause of the error is removed, the device deletes the error message.

(*) factory settings.

Chapter 12

PARAMETERS (PAr)

The parameters can be set to fully configure the **TM171VEV••** driver:

The parameters can be modified via:

- M171 Optimized Programming stick (**TM171AMFK**)
- keys on the M171 Optimized Display LED 32x74 terminal (**TM171DLED**)
- Personal Computer via M171 Optimized Programming cable (**TM171ADMI**)

⚠ WARNING
UNINTENDED EQUIPMENT OPERATION
The TM171VEV•• Valve driver must be power cycled after editing the BIOS parameters..
Failure to follow these instructions can result in death, serious injury, or equipment damage.

TABLES

Table	Description	Page
Parameters table	Contains the configuration parameters for the device saved in the device's non-volatile memory, including visibility information.	68
Valve Configuration Table	It contains a summary of the valve configuration parameter values.	75
Valve Configuration Table (dE00 = 0)	Contains the "Customizable" valve configuration parameters (dE00 = 0)	75
Valve Configuration Table (dE00 ≠ 0)	Contains the "Pre-set" valve configuration parameters (dE00 ≠ 0)	77
Folder visibility table	Lists the visibility of the parameter folders.	84
Client Table	Includes the I/O and alarm state resources available in the volatile memory of the device.	85

COLUMN DESCRIPTION

Column	Description
FOLDER	Indicates the label of the folder containing the parameter in question.
LABEL	Indicates the label used to display the parameters in the menu of the device.
PAR VAL ADDRESS	Indicates the address of the Modbus register containing the resource to be accessed.
PAR VIS ADDRESS	Indicates the address of the Modbus register containing the parameter visibility. By default all parameters have: Data size = 2 bit Range = 0...3 (see ' VISIBILITY OF PARAMETERS ' on page 68) UM = num
R/W	Indicates whether the resources are read/write, read only or write only: R = Read only resource W = Write only resource RW = Read/write resource
RESET	Indicates if the parameter modification requires the device to be reset. Y = YES, reset required N = NO, reset not required
DESCRIPTION	Description of the parameter function
DATA SIZE	Indicates the size of the parameter data: BYTE = 8 bit WORD = 16 bit "n" bit = 0...15 bit based on value of "n"
CPL	When the field indicates "Y" the value read by the register needs to be converted because the value represents a number with a sign. In the other cases the value is positive or null. To perform the conversion (two's complement), proceed as follows: If the value in the register is between 0 and 32,767, the result is the value itself (zero and positive values). If the value in the register is between 32,768 and 65,535, the result is the value of the register – 65,536 (negative values).
EXP	If the field shows -1 the value read by the register is divided by 10 (value/10) to convert it to the values indicated in the RANGE and DEFAULT columns using the unit of measurement in the UM column. Example: parameter CL04 = 50.0. Column EXP = -1: The value read by the device is 50.0 The value read by the register is 500 → 500/10 = 50.0
RANGE	Describes the interval of values that can be assigned to the parameter. It can be correlated with other parameters in the device (indicated with the parameter label). NOTE: If the value is beyond the specified limits for the parameter, instead of the effective value, the non-respected limit value is shown.
MODEL (DEFAULT)	Indicates the (default) setting for the reference code of the device. For parameters, the column is divided into the number of models issued as the defaults change.
UM	Unit of measurement for values converted according to the rules indicated in the CPL and EXP columns.

VISIBILITY OF PARAMETERS

According to the reference code, some configuration parameters may not be visible and/or many have no meaning as the associated resource is not present.

It is possible to configure four levels of visibility, assigning appropriate values to parameters and folders:

Value	Visibility level	Password
3	Visible parameters or folders.	No password required.
2	Manufacturer level. It is possible to view these parameters or folders only by entering the password defined in parameter UI28 . All parameters specified as visible and parameters visible at the installer level will be visible.	The password-protected objects are visible only if the correct password is entered (installer or manufacturer) using the password entry procedure. (see "SETTING THE PASSWORD (PAR/PASS)" page 45).
1	Manufacturer level. It is possible to view these parameters or folders only by entering the password defined in parameter UI27 . All parameters specified as always visible and parameters visible at the installer level will be visible.	
0	Parameter or folders <u>NOT</u> visible.	-

Unless otherwise indicated, the parameter is visible and can be modified, unless custom settings are configured via the serial port.

It is possible to verify the visibility of parameters and folders. Consult the folders table (see **"FOLDER VISIBILITY TABLE"** on page 84).

When modifying the visibility of the folder, the new setting applies to all parameters in the folder.

PARAMETERS/ VISIBILITY

The following sections analyse each parameter, divided into categories (folders):

Folder label	Meaning of acronym (label)	Parameters
dF	driver protocol configuration	Protocol Configuration
dL	driver Locator configuration	I/O configuration
dE	driver valve configuration	Valve configuration
Ui	User interface	User interface

FOLDER	LABEL	ADDRESS PAR VAL	ADDRESS PAR VIS	R/W	RESET	DESCRIPTION	DATA SIZE	CPL	EXP	RANGE	MODEL			UM
											TM171VEVM4	TM171VEVD4	TM171VEVA2	
Protocol configuration (folder "dF")														
dF	dF00	49159	49435.6	RW	N	Select protocol: <ul style="list-style-type: none"> • 0 = Reserved • 1 = Modbus • 2 = Reserved. • 3 = Reserved. 	BYTE	-	-	0...3	1	1	1	num
dF	dF02	49201	49436.2	RW	N	Control from digital inputs or serial port: <ul style="list-style-type: none"> • 0 = digital input • 1 = RS-485 (model TM171VEVM4) • 2* = RS-485 + shared probe (model TM171VEVM4) • 3* = digital input + shared probe (*) shared probe refers to a value written via serial to dedicated addresses, for the temperature/pressure probes configured but not connected. NOTE: If dL40 ≠0 and/or dL41 ≠0 the control comes from the serial. The Digital inputs DI1, DI2 (if configured ≠0) will ALWAYS have priority over commands received from the serial.	BYTE	-	-	0...3	1	0		num
dF	dF20	49173	49438.0	RW	N	Controller address. NOTE: The pair of values dF20 and dF21 represent the network address of the device and is indicated in the following format "FF.DD". (where FF=dF21 and DD=dF20).	BYTE	-	-	0...14	0	0	0	num
dF	dF21	49174	49438.2	RW	N	Controller family. See dF20 note.	BYTE	-	-	0...14	0	0	0	num
dF	dF30	49176	49438.6	RW	Y	Modbus protocol controller address	BYTE	-	-	0...255	1	1	1	num
dF	dF31	49177	49439.0	RW	Y	Modbus baud rate protocol: <ul style="list-style-type: none"> • 0 = 1200 baud • 1 = 2400 baud • 2 = 4800 baud • 3 = 9600 baud • 4 = 19200 baud • 5 = 38400 baud • 6 = 57600 baud • 7 = 115200 baud 	BYTE	-	-	0...7	3	3	3	num
dF	dF32	49178	49439.2	RW	Y	Modbus parity protocol: <ul style="list-style-type: none"> • 0 = NONE • 1 = EVEN • 2 = ODD 	BYTE	-	-	0...2	1	1	1	num
dF	dF60	16427	49441.0	RW	N	Customer code 1.	WORD	-	-	0...999	0	0	0	num
dF	dF61	16429	49441.2	RW	N	Customer code 2.	WORD	-	-	0...999	0	0	0	num
I/O configuration (Folder "dL")														
dL	dL00	50895	49430.2	RW	Y	Analog input AI1 type: <ul style="list-style-type: none"> • 0 = Probe not configured • 1 = NTC • 2 = Pt1000 • 3 = 4...20 mA • 4 = Ratiometric 0...5 V • 5 = 0...10 V • 6 = NTC extended 	BYTE	-	-	0...6	3	3	3	num

FOLDER	LABEL	ADDRESS PAR VAL	ADDRESS PAR VIS	R/W	RESET	DESCRIPTION	DATA SIZE	CPL	EXP	RANGE	MODEL			UM
											TM171VEVM4	TM171VEVD4	TM171VEVA2	
dL	dL01	50896	49430.4	RW	Y	Analog input AI2 type. Same as dL00 .	BYTE	-	-	0...6	3	3		num
dL	dL02	50897	49430.6	RW	Y	Analog input AI3 type: • 0 = Probe not configured • 1 = NTC • 2 = Pt1000 • 3, 4, 5 = Reserved; • 6 = NTC extended	BYTE	-	-	0...6	1	1		num
dL	dL03	50898	49431.0	RW	Y	Analog input AI4 type. Same as dL02 .	BYTE	-	-	0...6	1	1		num
dL	dL08	50924	49431.2	RW	N	°C/°F selection. 0 = °C; 1 = °F.	BYTE	-	-	0...1	0	0	0	flag
dL	dL09	50925	49431.4	RW	N	Pressure unit of measure. 0 = bar; 1 = psi.	BYTE	-	-	0...1	0	0	0	flag
dL	dL10	18131	49431.6	RW	N	Analog input AI1 fullscale value.	WORD	Y	-1	dL11...9999	7.0	7.0	7.0	bar/psi
dL	dL11	18141	49432.0	RW	N	Analog input AI1 start of scale value.	WORD	Y	-1	-145...dL10	-0.5	-0.5	-0.5	bar/psi
dL	dL12	18133	49432.2	RW	N	Analog input AI2 fullscale value.	WORD	Y	-1	dL13...9999	7.0	7.0		bar/psi
dL	dL13	18143	49432.4	RW	N	Analog input AI2 start of scale value.	WORD	Y	-1	-145...dL12	-0.5	-0.5		bar/psi
dL	dL20	50919	49432.6	RW	Y	Analog input AI1 differential.	BYTE	Y	-1	-120...120	0	0	0	bar/psi °C/°F
dL	dL21	50920	49433.0	RW	Y	Analog input AI2 differential.	BYTE	Y	-1	-120...120	0	0		bar/psi °C/°F
dL	dL22	50921	49433.2	RW	Y	Analog input AI3 differential.	BYTE	Y	-1	-120...120	0	0		°C/°F
dL	dL23	50922	49433.4	RW	Y	Analog input AI4 differential.	BYTE	Y	-1	-120...120	0	0		°C/°F
dL	dL30	50935	49433.6	RW	N	Analog input AI1 configuration. • 0 = disabled • 1 = evaporator output (superheat) • 2 = saturation • 3 = backup evaporator output (superheat) • 4 = backup saturation • 5 = valve opening direct control	BYTE	-	-	0...5	2	2	2	num
dL	dL31	50936	49434.0	RW	N	Analog input AI2 configuration. Same as dL30 .	BYTE	-	-	0...5	4	4		num
dL	dL32	50937	49434.2	RW	N	Analog input AI3 configuration. • 0 = disabled • 1 = evaporator output (superheat) • 2 = saturation • 3 = backup evaporator output (superheat) • 4 = backup saturation	BYTE	-	-	0...4	1	1		num
dL	dL33	50938	49434.4	RW	N	Analog input AI4 configuration. Same as dL32 .	BYTE	-	-	0...4	3	3		num
dL	dL40	50927	49434.6	RW	Y	Digital input DI1 configuration. • 0 = digital input not configured • ±1 = ON/OFF adjustment • ±2 = defrost • ±3 = alarm • ±4 = system operating mode (only mode 0 and 1) • ±5 = main serial communication protocol • ±6 = ON/OFF regulation with delay (OFF=50 % valve opening for 40 s) • ±7 = complete valve opening (see ' DIGITAL INPUTS ' on page 48)	BYTE	Y	-	-7...7	0	1		num
dL	dL41	50928	49435.0	RW	Y	Digital input DI2 configuration. Same as dL40 .	BYTE	Y	-	-7...7	0	2		num

FOLDER	LABEL	ADDRESS PAR VAL	ADDRESS PAR VIS	R/W	RESET	DESCRIPTION	DATA SIZE	CPL	EXP	RANGE	MODEL			UM
											TM171VEVM4	TM171VEVD4	TM171VEVA2	
dL	dL90	50941	49435.2	RW	Y	Digital output DO1 configuration. • 0 = output controlled from serial • ±1 = solenoid valve control • ±2 = alarm output (see ' DIGITAL OUTPUTS ' on page 48)	BYTE	Y	-	-2...2	0	0	0	num
dL	dL91	50942	49435.4	RW	Y	Digital output DO2 configuration (OC). Same as dL90 .	BYTE	Y	-	-2...2	0	0		num
Valve configuration (folder "dE")														
dE	dE00	49202	49443.0	RW	Y	Select valve. • 0 = Customizable • 1 = DANFOSS ETS-50 • 2 = DANFOSS ETS-100 • 3 = ALCO EX5/EX6 • 4 = RESERVED • 5 = ALCO EX7 • 6 = ALCO EX8 • 7 = RESERVED • 8 = SPORLAN SER • 9 = SPORLAN SEI-30 • 10 = SPORLAN SEI-50, SEH • 11 = RESERVED • 12 = SPORLAN SER (I) B/ C/ D/ G/ J/ K. • 13 = ELIWELL by Schneider Electric SXVB261●●●●●● (body 1) • 14 = RESERVED • 15 = ELIWELL by Schneider Electric SXVB262●●●●●● (body 2)/ SXVB263●●●●●● (body 3)	BYTE	-	-	0...15	1	1	1	num
Parameters dE01...dE09/dE80...dE82 are visible and settable from the keyboard only if dE00 = 0 . For the description of parameters dE01...dE09, dE80...dE82, see: <ul style="list-style-type: none"> • 'VALVE CONFIGURATION PARAMETERS' on page 75. • 'VALVE CONFIGURATION PARAMETERS WITH dE00 = 0' on page 75. • 'VALVE CONFIGURATION PARAMETERS WITH dE00 ≠ 0' on page 77. 														
dE	dE10	49209	49443.2	RW	N	Maximum valve opening percentage. Defines the maximum valve opening value, meaning the actuation limits in percentages. dE10 = 0 indicates that the valve is completely closed.	BYTE	-	-	0...100	100	100	100	%
dE	dE11	49210	49443.4	RW	N	Valve actuation percentage after blackout. Value calculated automatically but settable using this parameter for first start-up.	BYTE	-	-	0...100	0	0	0	%
dE	dE12	49211	49443.6	RW	N	Valve actuation percentage after defrost. Value calculated automatically but settable using this parameter for first start-up. If dE12=0 the percentage is defined by dE11 .	BYTE	-	-	0...100	0	0	0	%
dE	dE13	49212	49444.0	RW	N	Operating time at maximum opening for alarm signal. If the valve opening remains at a value of greater than dE10 for the time set by dE13 a maximum opening alarm will be given by drE7 (see ' Chapter 11 ' on page 64). If dE13=0 signal disabled.	BYTE	-	-	0...255	60	60	60	min

FOLDER	LABEL	ADDRESS PAR VAL	ADDRESS PAR VIS	R/W	RESET	DESCRIPTION	DATA SIZE	CPL	EXP	RANGE	MODEL			UM
											TM171VEVM4	TM171VEVD4	TM171VEVA2	
dE	dE14	49213	49444.2	RW	N	Minimum useful valve opening percentage. If the regulator commands an output with value \leq a dE14 , the actual output = 0.	BYTE	-	-	0...dE15	0	0	0	%
dE	dE15	49214	49444.4	RW	N	Maximum valve useful opening percentage. If the regulator commands an output with value \geq a dE15 , the actual output will be dE10 (with dE15 < dE10). Ignored if dE15 > dE10 .	BYTE	-	-	dL14...dL10	100	100	100	%
dE	dE16	49215	49444.6	RW	N	Valve opening percentage during evaporator output probe error. If a evaporator output probe error sets the valve opening, in percentage.	BYTE	-	-	0...100	0	0	0	%
dE	dE19	49223	49445.0	RW	N	Tolerance on stepper motor winding resistance.	BYTE	-	-	0...255	65	65	65	%
dE	dE93	49232	49445.2	RW	N	Motor activation/disabling time Sets the enabling/disabling cycles (Duty cycle) of the stepper motor. See dE08	BYTE	-	-	0...255	10	10	10	s*10
dE	dE20	49216	49445.4	RW	N	Select type of gas Use only if dip-switch is set to 7. Otherwise it will be ignored. <ul style="list-style-type: none"> • 0 = R404A • 1 = R448A • 2 = R410A • 3 = R134a • 4 = R744 (CO₂) • 5 = R407C • 6 = R427A • 7 = customizable 	BYTE	-	-	0...7	2	2	2	num
dE	dE21	49217	49445.6	RW	N	Type of system operating mode 0 <ul style="list-style-type: none"> • 0 = User Setting • 1 = ducted refrigeration unit and evaporation pressure quickly modifiable (for example step control) • 2 = ducted refrigeration unit and evaporation pressure controlled (for example INVERTER control) • 3 = refrigeration unit with on-board compressor • 4 = refrigeration unit with on-board compressor and renewing exchanger • 5 = Reserved • 6 = Reserved • 7 = conditioning unit with plate exchanger • 8 = conditioning unit with shell and tube exchanger • 9 = conditioning unit with ribbed battery exchanger • 10 = conditioning unit with variable refrigerating capacity • 11 = perturbed conditioning unit • 12...16 = Reserved 	BYTE	-	-	0...16	0	0	0	num

FOLDER	LABEL	ADDRESS PAR VAL	ADDRESS PAR VIS	R/W	RESET	DESCRIPTION	DATA SIZE	CPL	EXP	RANGE	MODEL			UM
											TM171VEVM4	TM171VEVD4	TM171VEVA2	
dE	dE22	49226	49446.0	RW	N	Type of system operating mode 1. Same as dE02 .	BYTE	-	-	0...16	0	0	0	num
dE	dE23	49227	49446.2	RW	N	Type of system operating mode 2. Same as dE02 .	BYTE	-	-	0...16	0	0	0	num
dE	dE24	49228	49446.4	RW	N	Type of system operating mode 3. Same as dE02 .	BYTE	-	-	0...16	0	0	0	num
dE	dE25	16493	49449.0	RW	N	Type of setting. 0 = PID linear regulation 1 = non linear threshold regulation	WORD	-	-	0...1	0	0	0	num
dE	dE26	16525	49449.2	RW	N	Proportional control coefficient (if dE25 = 1). 0.1 = maximum gain 999.9 = minimum gain	WORD	-	-	0.1...999.9	50.0	50.0	50.0	°C/°F
dE	dE27	16549	49449.4	RW	N	Integral regulator gain (if dE25 = 1).	WORD	-	-	0...1999	2	2	2	num
dE	dE28	16551	49449.6	RW	N	Valve activation recalculation period. (if dE25 = 1).	WORD	-	-	1...1999	2	2	2	s/10
dE	dE29	16553	49450.0	RW	N	Dead zone for proportional part (if dE25 = 1): - Err * > dE29 : proportional + integral regulation. - Err * < dE29 : integral regulation only. (* Err understood as absolute value	WORD	-	-	0.1...999.9	0.5	0.5	0.5	°C/°F
dE	dE30	49309	49446.6	RW	N	Enable superheat recalculation reference. Used to enable the automatic recalculation of the referred setpoint in order to regulate the superheat. 0 = recalculation disabled and setpoint equal to dE32 ; 1 = automatic recalculation enabled.	BYTE	-	-	0...1	0	0	0	flag
dE	dE31	16513	49447.0	RW	N	Superheat upper threshold Used to set the setpoint SP4 at dE31 to regulate the superheat following a black-out or at the end of defrost. Active for the time set by dE51 (or when the MOP function is disabled).	WORD	-	-1	0...1000	5.0	5.0	5.0	°C/°F
dE	dE32	16511	49447.2	RW	N	Superheat lower threshold Used to set the setpoint SP2 to regulate the superheat. If dE30 =0 the setpoint is forced to dE32 ; If dE30 =1 this is the minimum superheat setpoint value (the real setpoint value is calculate automatically between the dE32 and dE31 values).	WORD	-	-1	0...1000	5.0	5.0	5.0	°C/°F
dE	dE33	16515	49447.4	RW	N	Superheat reference recalculation period (if dE30 = 1) Defines the recalculation period of the dynamic setpoint (every dE33 seconds).	WORD	-	-	0...999	20	20	20	s
dE	dE34	16517	49447.6	RW	N	Superheat recalculation step Dynamic setpoint varies by dE34 degrees according to the superheat value compared to dE32 .	WORD	-	-1	0 ... 1000	0.1	0.1	0.1	°C/°F
dE	dE35	16471	49448.0	RW	N	Valve opening freezing timer after OFF → ON.	WORD	-	-	0 ... 1999	0	0	0	s
dE	dE36	16519	49448.2	RW	N	Superheat proportional band. (if dE25 = 0).	WORD	Y	-1	-9999 ... -1	-100	-100	-100	K
dE	dE37	16521	49448.4	RW	N	Superheat integral time (if dE25 = 0).	WORD	-	-	0 ... 1999	40	40	40	s

FOLDER	LABEL	ADDRESS PAR VAL	ADDRESS PAR VIS	R/W	RESET	DESCRIPTION	DATA SIZE	CPL	EXP	RANGE	MODEL			UM
											TM171VEVM4	TM171VEVD4	TM171VEVA2	
dE	dE38	16523	49448.6	RW	N	Superheat derivative time (if dE25 = 0).	WORD	-	-	0 ... 1999	0	0	0	s
dE	dE47	49330	49451.0	RW	N	Enable valve manual opening 0 = automatic valve opening 1 = manual valve opening	BYTE	-	-	0...1	0	0	0	flag
dE	dE48	16547	49451.2	RW	N	Manual valve opening (if dE47 =1) Valve opening switched from automatic to manual (dE47 =1), the opening percentage is not 0% as per default parameter but the percentage indicated by dE48 .	WORD	-	-1	0...1000	0	0	0	%
dE	dE49	49313	49450.2	RW	N	Superheat minimum percentage activation time.	BYTE	-	-	0...255	0	0	0	s
dE	dE50	49271	49451.4	RW	N	Enable MOP 0 = MOP disabled; 1 = MOP enabled.	BYTE	-	-	0...1	0	0	0	flag
dE	dE51	16479	49451.6	RW	N	MOP disable time at start-up. MOP activation delay on switching on or after defrost.	WORD	-	-	0...999	0	0	0	s
dE	dE52	16473	49452.0	RW	N	MOP setpoint. Evaporator temperature upper threshold	WORD	Y	-1	-600...1000	0.0	0.0	0.0	°C/°F
dE	dE53	49272	49452.2	RW	N	Min time that temperature upper threshold is exceeded for alarm activation. If the dE52 threshold is exceeded for more than the time set in dE53 the MOP alarm is given.	BYTE	-	-	0...255	180	180	180	s
dE	dE66	16495	49455.0	RW	N	Maximum valve opening variation compared to previous period. (if dE25 =1)	WORD	-	-1	1...1000	2.0	2.0	2.0	%/s
User Interface (folder "Ui")														
Ui	Ui27	17989	49459.6	RW	N	Installation engineer password	WORD	-	-	0...255	1	1	1	num
Ui	Ui28	17991	49460.0	RW	N	Manufacturer password	WORD	-	-	0...255	2	2	2	num

VALVE CONFIGURATION PARAMETERS

NOTE: The parametrizations listed below are presented in accordance with the technical documentation of the respective manufacturers but are subject to change without notice. Always consult the latest technical documentation of the manufacturer.

dE00	Type of VALVE	dE01 (steps/s)	dE02 (steps)	dE03 (steps)	dE04 (mA)	dE05 (Ohm)	dE06 (mA)	dE07 (num)	dE08 (%)	dE09 (10*ms/step)	dE80 (steps/s)	dE81 (ms)	dE82 (steps/10)
0	Customisable	35	415	100	-200	35	50	0	100	50	10	125	0
1	DANFOSS ETS 50	160	2625	160	100	52	75	0	100	50	15	0	0
2	DANFOSS ETS 100	300	3530	160	100	52	75	0	100	50	10	0	0
3	ALCO EX4/EX5/EX6	500	750	100	500	13	100	0	100	50	10	0	0
4	RESERVED	-	-	-	-	-	-	-	-	-	-	-	-
5	ALCO EX7	210	1600	100	750	8	250	0	100	50	10	0	0
6	ALCO EX8	500	2600	100	800	6	500	0	100	50	10	0	0
7	RESERVED	-	-	-	-	-	-	-	-	-	-	-	-
8	SPORLAN SER	200	1596	0	120	100	0	0	100	0	10	25	15
9	SPORLAN SEI-30	200	3193	0	160	75	0	0	100	0	10	25	30
10	SPORLAN SEI-50, SEH	200	6386	0	160	75	0	0	100	0	10	25	60
11	RESERVED	-	-	-	-	-	-	-	-	-	-	-	-
12	SPORLAN SER(I) B/ C/ D/ G/ J/ K/	200	2500	0	120	100	0	0	100	0	12	25	25
13	ELIWELL by Schneider Electric SXVB261●●●●●● (body 1)	35	415	100	-200	35	50	0	100	50	10	125	0
14	RESERVED	-	-	-	-	-	-	-	-	-	-	-	-
15	ELIWELL by Schneider Electric SXVB262●●●●●● (body 2) SXVB263●●●●●● (body 3)	20	195	60	-200	54	50	0	100	50	10	125	0

VALVE CONFIGURATION PARAMETERS WITH dE00 = 0

NOTE: The parameter visibility cannot be set via the serial. Verify the data given in the valve manufacturer's manual for the correct configuration.

dE00	LABEL	ADDRESS PAR. VALUE	R/W	DESCRIPTION	DATA SIZE	CPL	EXP	RANGE	DEFAULT	UM
0	dE01	16723	RW	Stepper motor maximum speed. Defines the maximum valve motor speed to allow step precision and integrity	WORD	-	-	0...9999	35	steps/s
0	dE02	16755	RW	Stepper motor complete opening. Defines the maximum number of valve steps. The total travel refers to the FULL STEP mode (dE07=0). The valve opening is complete when this value is reached.	WORD	-	-	0...9999	415	steps
0	dE03	49554	RW	Stepper motor extra movement in total closure. Defines the number of extra valve steps beyond the limit switch to allow a correct total closure. A total closure command implies the valve positioned to zero and a further number of steps dE03.	BYTE	-	-	0...255	100	steps

dE00	LABEL	ADDRESS PAR. VALUE	R/W	DESCRIPTION	DATA SIZE	CPL	EXP	RANGE	DEFAULT	UM
0	dE04	16803	RW	Stepper motor winding maximum current. Defines the maximum current per phase utilised by the valve (maximum torque). <u>Negative</u> current value: the maximum current will be set to the value with no sign (absolute) dE04 with an extra 50% with the valve movement command (starting or end point) within 5% of total opening, to a value equal to the absolute value of dE04 for the other movements.	WORD	-	-	-1999...9999	-200	mA
0	dE05	49602	RW	Stepper motor winding resistance. Defines the electrical resistance of the single phase winding (verify fault on connections).	BYTE	-	-	0...255	35	Ohm
0	dE06	16851	RW	Stepper motor winding rated current. Defines the phase circulating current in the valve stop condition (minimum torque).	WORD	-	-	0 ... 9999	50	mA
0	dE07	49650	RW	Type of stepper motor control. Defines the driving modes. • 0 = FULL STEP • 1 = HALF STEP • 2 = MICRO STEP • 3 = Reserved • 4 = Reserved • 5 = Reserved Refer to the technical documentation concerning the particular electronic valve for more detail.	BYTE	-	-	0 ... 5	0	num
0	dE08	50962	RW	Stepper motor enabling/disabling duty cycle. If the case of valve superheat, reduce the enabling duty cycle to allow it to cool down.	BYTE	-	-	0 ... 100	100	%
0	dE09	50978	RW	Stepper motor acceleration/deceleration. Defines the acceleration/deceleration in motor start/stop. The time between one step and the next is reduced by dE09 at each step until dE01 is reached. If dE09 = 0 acceleration is not applied.	BYTE	-	-	0 ... 255	50	ms*10/ step
0	dE80	50994	RW	Minimum stepper motor speed in acceleration/ deceleration. Defines the minimum motor acceleration/deceleration speed.	BYTE	-	-	0 ... 255	10	steps/s
0	dE81	51009	RW	Valve activation delay. Represents the waiting time that the valve requires before inverting the running direction, stopping regulation or starting regulation. If dE81 = 0 , it means that the parameter is not programmed.	BYTE	-	-	0...254	50	ms
0	dE82	49473	RW	Extra steps in total closing. Forces an extra number of steps beyond the closing limit switch every 24 hours of valve running to ensure total closing. If dE82 = 0 , it means that the parameter is not programmed.	BYTE	-	-	0...254	0	steps/10

VALVE CONFIGURATION PARAMETERS WITH dE00 ≠ 0

dE00	VALVE	LABEL	ADDRESS PAR. VALUE	R/W	DESCRIPTION	DATA SIZE	CPL	EXP	RANGE	DEFAULT	UM
1	DANFOSS ETS 50	dE01	16739	RW	Stepper motor maximum speed	WORD	-	-	0...9999	160	steps/s
1	DANFOSS ETS 50	dE02	16771	RW	Stepper motor complete opening	WORD	-	-	0...9999	2625	steps
1	DANFOSS ETS 50	dE03	49562	RW	Stepper motor extra movement in total closure	BYTE	-	-	0...255	160	steps
1	DANFOSS ETS 50	dE04	16819	RW	Maximum current stepper motor winding	WORD	-	-	-1999...9999	100	mA
1	DANFOSS ETS 50	dE05	49610	RW	Stepper motor winding resistance	BYTE	-	-	0...255	52	Ohm
1	DANFOSS ETS 50	dE06	16867	RW	Idle current stepper motor winding	WORD	-	-	0...9999	75	mA
1	DANFOSS ETS 50	dE07	49658	RW	Type of stepper motor control	BYTE	-	-	0...5	0	num
1	DANFOSS ETS 50	dE08	50970	RW	Stepper motor enabling/disabling duty cycle	BYTE	-	-	0...100	100	%
1	DANFOSS ETS 50	dE09	50986	RW	Stepper motor acceleration/ deceleration	BYTE	-	-	0...255	50	ms*10/ step
1	DANFOSS ETS 50	dE80	51002	RW	Minimum stepper motor speed in acceleration/deceleration	BYTE	-	-	0...255	15	steps/s
1	DANFOSS ETS 50	dE81	51018	RW	Valve pause time before reverse running, stop or start.	BYTE	-	-	0...254	0	ms
1	DANFOSS ETS 50	dE82	49482	RW	Stepper motor extra steps in total closure every 24 hours	BYTE	-	-	0...254	0	steps/10
2	DANFOSS ETS 100	dE01	16741	RW	Stepper motor maximum speed	WORD	-	-	0...9999	300	steps/s
2	DANFOSS ETS 100	dE02	16773	RW	Stepper motor complete opening	WORD	-	-	0...9999	3530	steps
2	DANFOSS ETS 100	dE03	49563	RW	Stepper motor extra movement in total closure	BYTE	-	-	0...255	160	steps
2	DANFOSS ETS 100	dE04	16821	RW	Maximum current stepper motor winding	WORD	-	-	-1999...9999	100	mA
2	DANFOSS ETS 100	dE05	49611	RW	Stepper motor winding resistance	BYTE	-	-	0...255	52	Ohm
2	DANFOSS ETS 100	dE06	16869	RW	Idle current stepper motor winding	WORD	-	-	0...9999	75	mA
2	DANFOSS ETS 100	dE07	49659	RW	Type of stepper motor control	BYTE	-	-	0...5	0	num
2	DANFOSS ETS 100	dE08	50971	RW	Stepper motor enabling/disabling duty cycle	BYTE	-	-	0...100	100	%
2	DANFOSS ETS 100	dE09	50987	RW	Stepper motor acceleration/ deceleration	BYTE	-	-	0...255	50	ms*10/ step
2	DANFOSS ETS 100	dE80	51003	RW	Minimum stepper motor speed in acceleration/deceleration	BYTE	-	-	0...255	10	steps/s
2	DANFOSS ETS 100	dE81	51019	RW	Valve pause time before reverse running, stop or start.	BYTE	-	-	0...254	0	ms
2	DANFOSS ETS 100	dE82	49483	RW	Stepper motor extra steps in total closure every 24 hours	BYTE	-	-	0...254	0	steps/10
3	ALCO EX4/EX5/EX6	dE01	16743	RW	Stepper motor maximum speed	WORD	-	-	0...9999	500	steps/s
3	ALCO EX4/EX5/EX6	dE02	16775	RW	Stepper motor complete opening	WORD	-	-	0...9999	750	steps

dE00	VALVE	LABEL	ADDRESS PAR. VALUE	R/W	DESCRIPTION	DATA SIZE	CPL	EXP	RANGE	DEFAULT	UM
3	ALCO EX4/EX5/EX6	dE03	49564	RW	Stepper motor extra movement in total closure	BYTE	-	-	0...255	100	steps
3	ALCO EX4/EX5/EX6	dE04	16823	RW	Stepper motor winding maximum current	WORD	-	-	-1999...9999	500	mA
3	ALCO EX4/EX5/EX6	dE05	49612	RW	Stepper motor winding resistance	BYTE	-	-	0...255	13	Ohm
3	ALCO EX4/EX5/EX6	dE06	16871	RW	Stepper motor winding rated current	WORD	-	-	0...9999	100	mA
3	ALCO EX4/EX5/EX6	dE07	49660	RW	Type of stepper motor control	BYTE	-	-	0..5	0	num
3	ALCO EX4/EX5/EX6	dE08	50972	RW	Stepper motor enabling/disabling duty cycle	BYTE	-	-	0...100	100	%
3	ALCO EX4/EX5/EX6	dE09	50988	RW	Stepper motor acceleration/ deceleration	BYTE	-	-	0...255	50	ms*10/ step
3	ALCO EX4/EX5/EX6	dE80	51004	RW	Minimum stepper motor speed in acceleration/deceleration	BYTE	-	-	0...255	10	steps/s
3	ALCO EX4/EX5/EX6	dE81	51020	RW	Valve pause time before reverse running, stop or start.	BYTE	-	-	0...254	0	ms
3	ALCO EX4/EX5/EX6	dE82	49484	RW	Stepper motor extra steps in total closure every 24 hours	BYTE	-	-	0...254	0	steps/10
4	RESERVED	dE01	16751	RW	Stepper motor maximum speed	WORD	-	-	0...9999	-	steps/s
4	RESERVED	dE02	16783	RW	Stepper motor complete opening	WORD	-	-	0...9999	-	steps
4	RESERVED	dE03	49568	RW	Stepper motor extra movement in total closure	BYTE	-	-	0...255	-	steps
4	RESERVED	dE04	16831	RW	Maximum current stepper motor winding	WORD	-	-	-1999...9999	-	mA
4	RESERVED	dE05	49616	RW	Stepper motor winding resistance	BYTE	-	-	0...255	-	Ohm
4	RESERVED	dE06	16879	RW	Idle current stepper motor winding	WORD	-	-	0...9999	-	mA
4	RESERVED	dE07	49664	RW	Type of stepper motor control	BYTE	-	-	0..5	-	num
4	RESERVED	dE08	50976	RW	Stepper motor enabling/disabling duty cycle	BYTE	-	-	0...100	-	%
4	RESERVED	dE09	50992	RW	Stepper motor acceleration/ deceleration	BYTE	-	-	0...255	-	ms*10/ step
4	RESERVED	dE80	51008	RW	Minimum stepper motor speed in acceleration/deceleration	BYTE	-	-	0...255	-	steps/s
4	RESERVED	dE81	51024	RW	Valve pause time before reverse running, stop or start.	BYTE	-	-	0...254	-	ms
4	RESERVED	dE82	49488	RW	Stepper motor extra steps in total closure every 24 hours	BYTE	-	-	0...254	-	steps/10
5	ALCO EX7	dE01	16745	RW	Stepper motor maximum speed	WORD	-	-	0...9999	210	steps/s
5	ALCO EX7	dE02	16777	RW	Stepper motor complete opening	WORD	-	-	0...9999	1600	steps
5	ALCO EX7	dE03	49565	RW	Stepper motor extra movement in total closure	BYTE	-	-	0...255	100	steps
5	ALCO EX7	dE04	16825	RW	Maximum current stepper motor winding	WORD	-	-	-1999...9999	750	mA

dE00	VALVE	LABEL	ADDRESS PAR. VALUE	R/W	DESCRIPTION	DATA SIZE	CPL	EXP	RANGE	DEFAULT	UM
5	ALCO EX7	dE05	49613	RW	Stepper motor winding resistance	BYTE	-	-	0...255	8	Ohm
5	ALCO EX7	dE06	16873	RW	Idle current stepper motor winding	WORD	-	-	0...9999	250	mA
5	ALCO EX7	dE07	49661	RW	Type of stepper motor control	BYTE	-	-	0...5	0	num
5	ALCO EX7	dE08	50973	RW	Stepper motor enabling/disabling duty cycle	BYTE	-	-	0...100	100	%
5	ALCO EX7	dE09	50989	RW	Stepper motor acceleration/ deceleration	BYTE	-	-	0...255	50	ms*10/ step
5	ALCO EX7	dE80	51005	RW	Minimum stepper motor speed in acceleration/deceleration	BYTE	-	-	0...255	10	steps/s
5	ALCO EX7	dE81	51021	RW	Valve pause time before reverse running, stop or start.	BYTE	-	-	0...254	0	ms
5	ALCO EX7	dE82	49485	RW	Stepper motor extra steps in total closure every 24 hours	BYTE	-	-	0...254	0	steps/10
6	ALCO EX8	dE01	16747	RW	Stepper motor maximum speed	WORD	-	-	0...9999	500	steps/s
6	ALCO EX8	dE02	16779	RW	Stepper motor complete opening	WORD	-	-	0...9999	2600	steps
6	ALCO EX8	dE03	49566	RW	Stepper motor extra movement in total closure	BYTE	-	-	0...255	100	steps
6	ALCO EX8	dE04	16827	RW	Maximum current stepper motor winding	WORD	-	-	-1999...9999	800	mA
6	ALCO EX8	dE05	49614	RW	Stepper motor winding resistance	BYTE	-	-	0...255	6	Ohm
6	ALCO EX8	dE06	16875	RW	Idle current stepper motor winding	WORD	-	-	0...9999	500	mA
6	ALCO EX8	dE07	49662	RW	Type of stepper motor control	BYTE	-	-	0...5	0	num
6	ALCO EX8	dE08	50974	RW	Stepper motor enabling/disabling duty cycle	BYTE	-	-	0...100	100	%
6	ALCO EX8	dE09	50990	RW	Stepper motor acceleration/ deceleration	BYTE	-	-	0...255	50	ms*10/ step
6	ALCO EX8	dE80	51006	RW	Minimum stepper motor speed in acceleration/deceleration	BYTE	-	-	0...255	10	steps/s
6	ALCO EX8	dE81	51022	RW	Valve pause time before reverse running, stop or start.	BYTE	-	-	0...254	0	ms
6	ALCO EX8	dE82	49486	RW	Stepper motor extra steps in total closure every 24 hours	BYTE	-	-	0...254	0	steps/10
7	RESERVED	dE01	16727	RW	Stepper motor maximum speed	WORD	-	-	0...9999	-	steps/s
7	RESERVED	dE02	16759	RW	Stepper motor complete opening	WORD	-	-	0...9999	-	steps
7	RESERVED	dE03	49556	RW	Stepper motor extra movement in total closure	BYTE	-	-	0...255	-	steps
7	RESERVED	dE04	16807	RW	Maximum current stepper motor winding	WORD	-	-	-1999...9999	-	mA
7	RESERVED	dE05	49604	RW	Stepper motor winding resistance	BYTE	-	-	0...255	-	Ohm
7	RESERVED	dE06	16855	RW	Idle current stepper motor winding	WORD	-	-	0...9999	-	mA
7	RESERVED	dE07	49652	RW	Type of stepper motor control	BYTE	-	-	0...5	-	num

dE00	VALVE	LABEL	ADDRESS PAR. VALUE	R/W	DESCRIPTION	DATA SIZE	CPL	EXP	RANGE	DEFAULT	UM
7	RESERVED	dE08	50964	RW	Stepper motor enabling/disabling duty cycle	BYTE	-	-	0...100	-	%
7	RESERVED	dE09	50980	RW	Stepper motor acceleration/ deceleration	BYTE	-	-	0...255	-	ms*10/ step
7	RESERVED	dE80	50996	RW	Minimum stepper motor speed in acceleration/deceleration	BYTE	-	-	0...255	-	steps/s
7	RESERVED	dE81	51012	RW	Valve pause time before reverse running, stop or start.	BYTE	-	-	0...254	-	ms
7	RESERVED	dE82	49476	RW	Stepper motor extra steps in total closure every 24 hours	BYTE	-	-	0...254	-	steps/10
8	Sporlan SER	dE01	16733	RW	Stepper motor maximum speed	WORD	-	-	0...9999	200	steps/s
8	Sporlan SER	dE02	16765	RW	Stepper motor complete opening	WORD	-	-	0...9999	1596	steps
8	Sporlan SER	dE03	49559	RW	Stepper motor extra movement in total closure	BYTE	-	-	0...255	0	steps
8	Sporlan SER	dE04	16813	RW	Maximum current stepper motor winding	WORD	-	-	-1999...9999	120	mA
8	Sporlan SER	dE05	49607	RW	Stepper motor winding resistance	BYTE	-	-	0...255	100	Ohm
8	Sporlan SER	dE06	16861	RW	Idle current stepper motor winding	WORD	-	-	0...9999	0	mA
8	Sporlan SER	dE07	49655	RW	Type of stepper motor control	BYTE	-	-	0..5	0	num
8	Sporlan SER	dE08	50967	RW	Stepper motor enabling/disabling duty cycle	BYTE	-	-	0...100	100	%
8	Sporlan SER	dE09	50983	RW	Stepper motor acceleration/ deceleration	BYTE	-	-	0...255	0	ms*10/ step
8	Sporlan SER	dE80	50999	RW	Minimum stepper motor speed in acceleration/deceleration	BYTE	-	-	0...255	10	steps/s
8	Sporlan SER	dE81	51015	RW	Valve pause time before reverse running, stop or start.	BYTE	-	-	0...254	25	ms
8	Sporlan SER	dE82	49479	RW	Stepper motor extra steps in total closure every 24 hours	BYTE	-	-	0...254	15	steps/10
9	Sporlan SEI-30	dE01	16735	RW	Stepper motor maximum speed	WORD	-	-	0...9999	200	steps/s
9	Sporlan SEI-30	dE02	16767	RW	Stepper motor complete opening	WORD	-	-	0...9999	3193	steps
9	Sporlan SEI-30	dE03	49560	RW	Stepper motor extra movement in total closure	BYTE	-	-	0...255	0	steps
9	Sporlan SEI-30	dE04	16815	RW	Stepper motor winding maximum current	WORD	-	-	-1999...9999	160	mA
9	Sporlan SEI-30	dE05	49608	RW	Stepper motor winding resistance	BYTE	-	-	0...255	75	Ohm
9	Sporlan SEI-30	dE06	16863	RW	Stepper motor winding rated current	WORD	-	-	0...9999	0	mA
9	Sporlan SEI-30	dE07	49656	RW	Type of stepper motor control	BYTE	-	-	0..5	0	num
9	Sporlan SEI-30	dE08	50968	RW	Stepper motor enabling/disabling duty cycle	BYTE	-	-	0...100	100	%
9	Sporlan SEI-30	dE09	50984	RW	Stepper motor acceleration/ deceleration	BYTE	-	-	0...255	0	ms*10/ step

dE00	VALVE	LABEL	ADDRESS PAR. VALUE	R/W	DESCRIPTION	DATA SIZE	CPL	EXP	RANGE	DEFAULT	UM
9	Sporlan SEI-30	dE80	51000	RW	Minimum stepper motor speed in acceleration/deceleration	BYTE	-	-	0...255	10	steps/s
9	Sporlan SEI-30	dE81	51016	RW	Valve pause time before reverse running, stop or start.	BYTE	-	-	0...254	25	ms
9	Sporlan SEI-30	dE82	49480	RW	Stepper motor extra steps in total closure every 24 hours	BYTE	-	-	0...254	30	steps/10
10	Sporlan SEI-50, SEH	dE01	16737	RW	Stepper motor maximum speed	WORD	-	-	0...9999	200	steps/s
10	Sporlan SEI-50, SEH	dE02	16769	RW	Stepper motor complete opening	WORD	-	-	0...9999	6386	steps
10	Sporlan SEI-50, SEH	dE03	49561	RW	Stepper motor extra movement in total closure	BYTE	-	-	0...255	0	steps
10	Sporlan SEI-50, SEH	dE04	16817	RW	Maximum current stepper motor winding	WORD	-	-	-1999...9999	160	mA
10	Sporlan SEI-50, SEH	dE05	49609	RW	Stepper motor winding resistance	BYTE	-	-	0...255	75	Ohm
10	Sporlan SEI-50, SEH	dE06	16865	RW	Idle current stepper motor winding	WORD	-	-	0...9999	0	mA
10	Sporlan SEI-50, SEH	dE07	49657	RW	Type of stepper motor control	BYTE	-	-	0...5	0	num
10	Sporlan SEI-50, SEH	dE08	50969	RW	Stepper motor enabling/disabling duty cycle	BYTE	-	-	0...100	100	%
10	Sporlan SEI-50, SEH	dE09	50985	RW	Stepper motor acceleration/ deceleration	BYTE	-	-	0...255	0	ms*10/step
10	Sporlan SEI-50, SEH	dE80	51001	RW	Minimum stepper motor speed in acceleration/deceleration	BYTE	-	-	0...255	10	steps/s
10	Sporlan SEI-50, SEH	dE81	51017	RW	Valve pause time before reverse running, stop or start.	BYTE	-	-	0...254	25	ms
10	Sporlan SEI-50, SEH	dE82	49481	RW	Stepper motor extra steps in total closure every 24 hours	BYTE	-	-	0...254	60	steps/10
11	RESERVED	dE01	16751	RW	Stepper motor maximum speed	WORD	-	-	0...9999	-	steps/s
11	RESERVED	dE02	16783	RW	Stepper motor complete opening	WORD	-	-	0...9999	-	steps
11	RESERVED	dE03	49568	RW	Stepper motor extra movement in total closure	BYTE	-	-	0...255	-	steps
11	RESERVED	dE04	16831	RW	Maximum current stepper motor winding	WORD	-	-	-1999...9999	-	mA
11	RESERVED	dE05	49616	RW	Stepper motor winding resistance	BYTE	-	-	0...255	-	Ohm
11	RESERVED	dE06	16879	RW	Idle current stepper motor winding	WORD	-	-	0...9999	-	mA
11	RESERVED	dE07	49664	RW	Type of stepper motor control	BYTE	-	-	0...5	-	num
11	RESERVED	dE08	50976	RW	Stepper motor enabling/disabling duty cycle	BYTE	-	-	0...100	-	%
11	RESERVED	dE09	50992	RW	Stepper motor acceleration/ deceleration	BYTE	-	-	0...255	-	ms*10/step
11	RESERVED	dE80	51008	RW	Minimum stepper motor speed in acceleration/deceleration	BYTE	-	-	0...255	-	steps/s
11	RESERVED	dE81	51024	RW	Valve pause time before reverse running, stop or start.	BYTE	-	-	0...254	-	ms
11	RESERVED	dE82	49488	RW	Stepper motor extra steps in total closure every 24 hours	BYTE	-	-	0...254	-	steps/10

dE00	VALVE	LABEL	ADDRESS PAR. VALUE	R/W	DESCRIPTION	DATA SIZE	CPL	EXP	RANGE	DEFAULT	UM
12	Sporlan SER (I) B/ C/ D/ G/ J/ K/	dE01	16731	RW	Stepper motor maximum speed	WORD	-	-	0...9999	200	steps/s
12	Sporlan SER (I) B/ C/ D/ G/ J/ K/	dE02	16763	RW	Stepper motor complete opening	WORD	-	-	0...9999	2500	steps
12	Sporlan SER (I) B/ C/ D/ G/ J/ K/	dE03	49558	RW	Stepper motor extra movement in total closure	BYTE	-	-	0...255	0	steps
12	Sporlan SER (I) B/ C/ D/ G/ J/ K/	dE04	16811	RW	Maximum current stepper motor winding	WORD	-	-	-1999...9999	120	mA
12	Sporlan SER (I) B/ C/ D/ G/ J/ K/	dE05	49606	RW	Stepper motor winding resistance	BYTE	-	-	0...255	100	Ohm
12	Sporlan SER (I) B/ C/ D/ G/ J/ K/	dE06	16859	RW	Idle current stepper motor winding	WORD	-	-	0...9999	0	mA
12	Sporlan SER (I) B/ C/ D/ G/ J/ K/	dE07	49654	RW	Type of stepper motor control	BYTE	-	-	0...5	0	num
12	Sporlan SER (I) B/ C/ D/ G/ J/ K/	dE08	50966	RW	Stepper motor enabling/disabling duty cycle	BYTE	-	-	0...100	100	%
12	Sporlan SER (I) B/ C/ D/ G/ J/ K/	dE09	50982	RW	Stepper motor acceleration/ deceleration	BYTE	-	-	0...255	0	ms*10/ step
12	Sporlan SER (I) B/ C/ D/ G/ J/ K/	dE80	50998	RW	Minimum stepper motor speed in acceleration/deceleration	BYTE	-	-	0...255	12	steps/s
12	Sporlan SER (I) B/ C/ D/ G/ J/ K/	dE81	51014	RW	Valve pause time before reverse running, stop or start.	BYTE	-	-	0...254	25	ms
12	Sporlan SER (I) B/ C/ D/ G/ J/ K/	dE82	49478	RW	Stepper motor extra steps in total closure every 24 hours	BYTE	-	-	0...254	25	steps/10
13	ELIWELL by Schneider Electric SXVB261●●●●●●	dE01	16723	RW	Stepper motor maximum speed	WORD	-	-	0...9999	35	steps/s
13	ELIWELL by Schneider Electric SXVB261●●●●●●	dE02	16755	RW	Stepper motor complete opening	WORD	-	-	0...9999	415	steps
13	ELIWELL by Schneider Electric SXVB261●●●●●●	dE03	49554	RW	Stepper motor extra movement in total closure	BYTE	-	-	0...255	100	steps
13	ELIWELL by Schneider Electric SXVB261●●●●●●	dE04	16803	RW	Stepper motor winding maximum current	WORD	-	-	-1999...9999	-200	mA
13	ELIWELL by Schneider Electric SXVB261●●●●●●	dE05	49602	RW	Stepper motor winding resistance	BYTE	-	-	0...255	35	Ohm
13	ELIWELL by Schneider Electric SXVB261●●●●●●	dE06	16851	RW	Stepper motor winding rated current	WORD	-	-	0...9999	50	mA
13	ELIWELL by Schneider Electric SXVB261●●●●●●	dE07	49650	RW	Type of stepper motor control	BYTE	-	-	0..5	0	num
13	ELIWELL by Schneider Electric SXVB261●●●●●●	dE08	50962	RW	Stepper motor enabling/disabling duty cycle	BYTE	-	-	0...100	100	%
13	ELIWELL by Schneider Electric SXVB261●●●●●●	dE09	50978	RW	Stepper motor acceleration/ deceleration	BYTE	-	-	0...255	50	ms*10/ step
13	ELIWELL by Schneider Electric SXVB261●●●●●●	dE80	50994	RW	Minimum stepper motor speed in acceleration/deceleration	BYTE	-	-	0...255	10	steps/s
13	ELIWELL by Schneider Electric SXVB261●●●●●●	dE81	51010	RW	Valve pause time before reverse running, stop or start.	BYTE	-	-	0...254	125	ms

dE00	VALVE	LABEL	ADDRESS PAR. VALUE	R/W	DESCRIPTION	DATA SIZE	CPL	EXP	RANGE	DEFAULT	UM
13	ELIWELL by Schneider Electric SXVB261●●●●●●	dE82	49474	RW	Stepper motor extra steps in total closure every 24 hours	BYTE	-	-	0...254	0	steps/10
14	RESERVED	dE01	16729	RW	Stepper motor maximum speed	WORD	-	-	0...9999	-	steps/s
14	RESERVED	dE02	16761	RW	Stepper motor complete opening	WORD	-	-	0...9999	-	steps
14	RESERVED	dE03	49557	RW	Stepper motor extra movement in total closure	BYTE	-	-	0...255	-	steps
14	RESERVED	dE04	16809	RW	Stepper motor winding maximum current	WORD	-	-	-1999...9999	-	mA
14	RESERVED	dE05	49605	RW	Stepper motor winding resistance	BYTE	-	-	0...255	-	Ohm
14	RESERVED	dE06	16857	RW	Stepper motor winding rated current	WORD	-	-	0...9999	-	mA
14	RESERVED	dE07	49653	RW	Type of stepper motor control	BYTE	-	-	0...5	-	num
14	RESERVED	dE08	50965	RW	Stepper motor enabling/disabling duty cycle	BYTE	-	-	0...100	-	%
14	RESERVED	dE09	50981	RW	Stepper motor acceleration/ deceleration	BYTE	-	-	0...255	-	ms*10/ step
14	RESERVED	dE80	50997	RW	Minimum stepper motor speed in acceleration/deceleration	BYTE	-	-	0...255	-	steps/s
14	RESERVED	dE81	51013	RW	Valve pause time before reverse running, stop or start.	BYTE	-	-	0...254	-	ms
14	RESERVED	dE82	49477	RW	Stepper motor extra steps in total closure every 24 hours	BYTE	-	-	0...254	-	steps/10
15	ELIWELL by Schneider Electric SXVB262●●●●●●/ SXVB263●●●●●●	dE01	16725	RW	Stepper motor maximum speed	WORD	-	-	0...9999	20	steps/s
15	ELIWELL by Schneider Electric SXVB262●●●●●●/ SXVB263●●●●●●	dE02	16757	RW	Stepper motor complete opening	WORD	-	-	0...9999	195	steps
15	ELIWELL by Schneider Electric SXVB262●●●●●●/ SXVB263●●●●●●	dE03	49555	RW	Stepper motor extra movement in total closure	BYTE	-	-	0...255	60	steps
15	ELIWELL by Schneider Electric SXVB262●●●●●●/ SXVB263●●●●●●	dE04	16805	RW	Maximum current stepper motor winding	WORD	-	-	-1999...9999	-200	mA
15	ELIWELL by Schneider Electric SXVB262●●●●●●/ SXVB263●●●●●●	dE05	49603	RW	Stepper motor winding resistance	BYTE	-	-	0...255	54	Ohm
15	ELIWELL by Schneider Electric SXVB262●●●●●●/ SXVB263●●●●●●	dE06	16853	RW	Idle current stepper motor winding	WORD	-	-	0...9999	50	mA
15	ELIWELL by Schneider Electric SXVB262●●●●●●/ SXVB263●●●●●●	dE07	49651	RW	Type of stepper motor control	BYTE	-	-	0...5	0	num

dE00	VALVE	LABEL	ADDRESS PAR. VALUE	R/W	DESCRIPTION	DATA SIZE	CPL	EXP	RANGE	DEFAULT	UM
15	ELIWELL by Schneider Electric SXVB262●●●●●●/ SXVB263●●●●●●	dE08	50963	RW	Stepper motor enabling/disabling duty cycle	BYTE	-	-	0...100	100	%
15	ELIWELL by Schneider Electric SXVB262●●●●●●/ SXVB263●●●●●●	dE09	50979	RW	Stepper motor acceleration/ deceleration	BYTE	-	-	0...255	50	ms*10/ step
15	ELIWELL by Schneider Electric SXVB262●●●●●●/ SXVB263●●●●●●	dE80	50995	RW	Minimum stepper motor speed in acceleration/deceleration	BYTE	-	-	0...255	10	steps/s
15	ELIWELL by Schneider Electric SXVB262●●●●●●/ SXVB263●●●●●●	dE81	51011	RW	Valve pause time before reverse running, stop or start.	BYTE	-	-	0...254	125	ms
15	ELIWELL by Schneider Electric SXVB262●●●●●●/ SXVB263●●●●●●	dE82	49475	RW	Stepper motor extra steps in total closure every 24 hours	BYTE	-	-	0...254	0	steps/10

FOLDER VISIBILITY TABLE

FOLDER	ADDRESS PAR VAL	R/W	DESCRIPTION	DATA SIZE	CPL	EXP	RANGE	MODEL			UM
								TM171VEVM4	TM171VEVD4	TM171VEVA2	
rE	49425.0	RW	Folder visibility	2 bit	-	-	0...3	3	3	3	num
Ai	49425.2	RW	Folder visibility	2 bit	-	-	0...3	3	3	3	num
of	49425.4	RW	Folder visibility	2 bit	-	-	0...3	3	3	3	num
dO	49425.6	RW	Folder visibility	2 bit	-	-	0...3	3	3	3	num
SP	49426.0	RW	Folder visibility	2 bit	-	-	0...3	3	3	3	num
PAr	49426.2	RW	Folder visibility	2 bit	-	-	0...3	3	3	3	num
FnC	49426.4	RW	Folder visibility	2 bit	-	-	0...3	3	3	3	num
PASS	49426.6	RW	Folder visibility	2 bit	-	-	0...3	3	3	3	num
SP1	49427.2	RW	Folder visibility	2 bit	-	-	0...3	3	3	3	num
SP2	49427.4	RW	Folder visibility	2 bit	-	-	0...3	3	3	3	num
SP3	49427.6	RW	Folder visibility	2 bit	-	-	0...3	3	3	3	num
SP4	49428.0	RW	Folder visibility	2 bit	-	-	0...3	3	3	3	num
dF	49428.4	RW	Folder visibility	2 bit	-	-	0...3	3	3	3	num
dL	49428.2	RW	Folder visibility	2 bit	-	-	0...3	3	3	3	num
dE	49428.6	RW	Folder visibility	2 bit	-	-	0...3	3	3	3	num
UI	49429.0	RW	Folder visibility	2 bit	-	-	0...3	3	3	3	num
CC	49429.2	RW	Folder visibility	2 bit	-	-	0...3	3	3	3	num
UL	49460.2	RW	Folder visibility	2 bit	-	-	0...3	3	3	3	num
DL	49460.4	RW	Folder visibility	2 bit	-	-	0...3	3	3	3	num
FR	49460.6	RW	Folder visibility	2 bit	-	-	0...3	3	3	3	num
dF43	49450.0	RW	Folder visibility	2 bit	-	-	0...3	3	3	3	num
dF44	49450.2	RW	Folder visibility	2 bit	-	-	0...3	3	3	3	num

RESOURCE TABLE

FOLDER	LABEL	ADDRESS PAR. VALUE	R/W	DESCRIPTION	DATA SIZE	CPL	EXP	RANGE	UM
Ai	dAi1	564	R	Analog input (display) 1	WORD	Y	-1	-500...9999	°C/°F/ bar/psi
Ai	dAi2	566	R	Analog Input (display) 2	WORD	Y	-1	-500...9999	°C/°F/ bar/psi
Ai	dAi3	568	R	Analog Input (display) 3	WORD	Y	-1	-500...9999	°C/°F
Ai	dAi4	570	R	Analog Input (display) 4	WORD	Y	-1	-500...9999	°C/°F
Ai	drE1	433	R	Valve superheat temperature EEVD	WORD	Y	-1	-500...9999	°C/°F
Ai	drE2	435	R	Valve saturation temperature EEVD	WORD	Y	-1	-500...9999	°C/°F
Ai	drE3	437	R	Valve superheat temperature EEVD (backup)	WORD	Y	-1	-500...9999	°C/°F
Ai	drE4	439	R	Valve saturation temperature EEVD (backup)	WORD	Y	-1	-500...9999	°C/°F
Ai	drE5	447	R	Valve superheat EEVD	WORD	Y	-1	-500...9999	K/°R
Ai	drE6	449	R	Valve evaporator pressure EEVD	WORD	Y	-1	-500...9999	bar/psi
Ai	drE7	451	R	Valve opening percentage EEVD	WORD	-	-1	-500...9999	%
Ai	SP4	520	R	Valve superheat setpoint EEVD	WORD	Y	-1	-500...9999	K/°R
Ai	evaporatorPress	526	R/W	Remote valve evaporator pressure*	WORD	Y	-1	-500...9999	psi
Ai	evaporatorTemp	528	R/W	Valve saturation temperature from remote*	WORD	Y	-1	-500...9999	°F
Di	ddi1	33063.0	R	Digital input 1	1 bit	-	-	0...1	flag
Di	ddi2	33063.1	R	Digital input 2	1 bit	-	-	0...1	flag
Di	Dip1	33059.1	R	dip-switch 1 status	1 bit	-	-	0...1	flag
Di	Dip2	33059.2	R	dip-switch 2 status	1 bit	-	-	0...1	flag
Di	Dip3	33059.3	R	dip-switch 3 status	1 bit	-	-	0...1	flag
Di	Dip4	33059.4	R	dip-switch 4 status	1 bit	-	-	0...1	flag
Di	Dip5	33059.5	R	dip-switch 5 status	1 bit	-	-	0...1	flag
Di	Dip6	33059.6	R	dip-switch 6 status	1 bit	-	-	0...1	flag
dO	ddO1	33064.6	R	Digital output dO1	1 bit	-	-	0...1	flag
dO	ddO2	33064.5	R	Digital output dO2	1 bit	-	-	0...1	flag
Alarm	Er01	33053.1	R	Probe error Ai1	1 bit	-	-	0...1	flag
Alarm	Er02	33053.2	R	Probe error Ai2	1 bit	-	-	0...1	flag
Alarm	Er03	33053.3	R	Probe error Ai3	1 bit	-	-	0...1	flag
Alarm	Er04	33053.4	R	Probe error Ai4	1 bit	-	-	0...1	flag
Alarm	Er05	33053.5	R	Valve superheat probe alarm EEVD	1 bit	-	-	0...1	flag
Alarm	Er06	33053.6	R	Valve saturation probe alarm EEVD	1 bit	-	-	0...1	flag
Alarm	Er07	33053.7	R	Valve MOP alarm EEVD	1 bit	-	-	0...1	flag
Alarm	Er08	33054.0	R	Valve output max alarm EEVD	1 bit	-	-	0...1	flag
Alarm	Er09	33054.1	R	Valve external alarm EEVD	1 bit	-	-	0...1	flag
Alarm	Er10	33054.2	R	Valve no-link alarm EEVD	1 bit	-	-	0...1	flag
Alarm	Er11	33054.3	R	Valve motor alarm EEVD: high current absorption	1 bit	-	-	0...1	flag
Alarm	Er12	33054.4	R	Valve motor alarm EEVD: Coil winding 1 not connected.	1 bit	-	-	0...1	flag

FOLDER	LABEL	ADDRESS PAR. VALUE	R/W	DESCRIPTION	DATA SIZE	CPL	EXP	RANGE	UM
Alarm	Er13	33054.5	R	Valve motor alarm EEVD: Coil winding 1 in short circuit	1 bit	-	-	0...1	flag
Alarm	Er14	33054.6	R	Valve motor alarm EEVD: Coil winding 2 not connected	1 bit	-	-	0...1	flag
Alarm	Er15	33054.7	R	Valve motor alarm EEVD: Coil winding 2 in short circuit	1 bit	-	-	0...1	flag
State	EEV_STTS_ON	33258.0	R	Enable EEVD valve control	1 bit	-	-	0...1	flag
State	EEV_STTS_ALM	33258.1	R	EEVD alarm	1 bit	-	-	0...1	flag
State	EEV_STTS_DEFR	33258.2	R	EEVD defrost	1 bit	-	-	0...1	flag
State	EEV_STTS_NOLINK	33258.3	R	control status in no-link	1 bit	-	-	0...1	flag
State	EEV_STTS_MOD	33258.4	R	Select operating mode	2 bit	-	-	0...3	num
State	EEV_STTS_SPECIAL_ON	33258.6	R	Opening state of fixed valve before EEVD closure	1 bit	-	-	0...1	num
State	EEV_STTS_FORCE_OPEN	33258.7	R	Forced complete EEVC valve opening state	1 bit	-	-	0...1	num
Net Command	EEV_STTS_ON_SET	33260.0	W	Valve control ON	1 bit	-	-	0...1	flag
Net Command	EEV_STTS_ALM_SET	33260.1	W	Alarm status ON	1 bit	-	-	0...1	flag
Net Command	EEV_STTS_DEFR_SET	33260.2	W	Defrost status ON	1 bit	-	-	0...1	flag
Net Command	EEV_STTS_SPECIAL_ON_SET	33260.6	W	Valve opening command FIX ON	1 bit	-	-	0...1	flag
Net Command	EEV_STTS_FORCE_OPEN_SET	33260.7	W	Valve opening command 100% ON	1 bit	-	-	0...1	flag
Net Command	EEV_STTS_MOD_SET	33260.4	W	Selection command operating mode 0: 00 → Control 1 1: 01 → Control 2 2: 10 → Control 3 3: 11 → Control 4	2 bit	-	-	0...3	num
Net Command	EEV_STTS_ON_RESET	33260.0	W	Valve control OFF	1 bit	-	-	0...1	flag
Net Command	EEV_STTS_ALM_RESET	33260.1	W	Alarm status OFF	1 bit	-	-	0...1	flag
Net Command	EEV_STTS_DEFR_RESET	33260.2	W	Defrost status OFF	1 bit	-	-	0...1	flag
Net Command	EEV_STTS_SPECIAL_ON_RESET	33260.6	W	Valve opening command FIX OFF	1 bit	-	-	0...1	flag
Net Command	EEV_STTS_FORCE_OPEN_RESET	33260.7	W	Valve opening command 100% OFF	1 bit	-	-	0...1	flag
Ai	Remote_Setp_Overheating	577	R/W	Auxiliary regulator 1	WORD	Y	-1	-500...9999	K/R
Ai	Remote_Setp_MOP	579	R/W	Auxiliary regulator 2	WORD	Y	-1	-500...9999	K/R
Ai	TimeOut_Remote_Setp_Overheating	573	R/W	Auxiliary regulator 3	WORD	-	-	0...65535	s
Ai	TimeOut_Remote_Setp_MOP	575	R/W	Auxiliary regulator 4	WORD	-	-	0...65535	s
Ai	Remote_Percentage	494	R/W	Valve EEVD opening percentage	WORD	-	-1	0...1000	%

(*) shared probe

Eliwell Controls s.r.l.

Via dell'Industria, 15 • Zona Industriale Paludi •

32016 Alpago (BL) ITALY

T: +39 0437 986 111

www.eliwell.com

Sales:

T: +39 0437 986 100 (Italy)

T: +39 0437 986 200 (other countries)

E: saleseliwell@schneider-electric.com

Technical Customer Support

T: +39 0437 986 300

E: techsuppeliwell@schneider-electric.com

MADE IN ITALY

cod. EIO0000002034.01 • TM171VEV • rel.10/18 • EN
© 2018 Schneider Electric • All rights reserved