

Modicon M171 Performance Logic Controller

Hardware Guide

09/2015



The information provided in this documentation contains general descriptions and/or technical characteristics of the performance of the products contained herein. This documentation is not intended as a substitute for and is not to be used for determining suitability or reliability of these products for specific user applications. It is the duty of any such user or integrator to perform the appropriate and complete risk analysis, evaluation and testing of the products with respect to the relevant specific application or use thereof. Neither Schneider Electric nor any of its affiliates or subsidiaries shall be responsible or liable for misuse of the information contained herein.

If you have any suggestions for improvements or amendments or have found errors in this publication, please notify us.

No part of this document may be reproduced in any form or by any means, electronic or mechanical, including photocopying, without express written permission of Schneider Electric.

All pertinent state, regional, and local safety regulations must be observed when installing and using this product. For reasons of safety and to help ensure compliance with documented system data, only the manufacturer should perform repairs to components.

When devices are used for applications with technical safety requirements, the relevant instructions must be followed.

Failure to use Schneider Electric software or approved software with our hardware products may result in injury, harm, or improper operating results.

Failure to observe this information can result in injury or equipment damage.

© 2015 Schneider Electric. All rights reserved.

TABLE OF CONTENTS



CHAPTER	1. Introduction	12
	1.1. General description of Modicon M171 Performance	12
	1.1.1. Modicon M171 Performance offer	12
CHAPTER	2. Mechanical installation	15
	2.1. Before Starting	15
	2.2. Disconnecting Power	15
	2.3. Programming Considerations	16
	2.4. Operating Environment	16
	2.5. Installation Considerations	16
	2.6. TM171PDM27● / TM171PBM27R / TM171EP●●R installation	18
	2.7. Assembling the TM171A●●●● Communication Modules	20
	2.8. Assembling the M171 Performance Flush or TM171DGRP	21
	2.8.1. Panel mounting	21
	2.8.2. Accessories for Wall mounting	22
CHAPTER	3. Electrical connections	23
	3.1. Wiring Best Practices	23
	3.1.1. Wiring Guidelines	23
	3.1.2. Rules for Removable Screw Terminal Block	24
	3.1.3. Protecting Outputs from Inductive Load Damage	25
	3.1.4. Special handling considerations	27
	3.1.5. Analog Inputs-Probes	27
	3.1.6. Serial connections	27
	3.2. Wiring diagrams	30
	3.2.1. Modicon M171P wiring diagram	30
	3.2.2. Modicon M171EP14R wiring diagram	32
	3.2.3. Examples of analog input connection (M171 Performance only)	33
	3.2.4. M171 Performance / M171 Display Graphic connection	37
	3.2.5. M171 Performance Flush TM171PFE03 and TM171PFE03HR connection	38
	3.3. M171 Performance protocol connectivity	40
	3.3.1. Example: CAN (Field) network connection	40

3.3.2. Example: CAN connection (Network).....	41
3.3.3. Example: RS485 connection (Field).....	42
3.3.4. Example: RS485 connection with the Modicon M171O network.....	43
3.4. M171 Performance Flush protocol connectivity	44
3.4.1. Example: RS485 connection (Field).....	44
3.4.2. Example: CAN connection	44
3.4.3. Example: RS485 connection with the Modicon M171O network.....	45
3.4.4. Example: CAN network connection.....	46
3.5. TM171A●●●● Communication Modules	47
3.5.1. Communication Modules compatible with M171 and M172	47
3.5.2. Communication Modules exclusively compatible with M171.....	48
3.5.3. TM171ARS232.....	51
3.5.4. TM171AETH / TM171AETHRS485.....	53
3.5.5. Example: BACnet / IP.....	54
3.5.6. TM171AMB.....	57
3.5.7. TM171ARS485 / TM171AETHRS485	58
3.5.8. TM171ACAN	59
3.5.9. TM171APBUS	60
3.5.10. TM171ALON.....	61
3.6. Ethernet connection (for M171 Performance Flush)	62

CHAPTER 4. Technical data 64

4.1. General specifications.....	64
4.2. I/O features	66
4.2.1. M171 Performance I/O features	66
4.2.2. M171EP14R Performance I/O features.....	68
4.2.3. M171 Performance Flush I/O features	69
4.3. Display	70
4.3.1. M171 Performance Display Graphic / M171 Performance Flush display.....	70
4.4. Serials	70
4.4.1. TM171A●●●● Communication Module	71
4.5. Power supply.....	72
4.6. Mechanical dimensions.....	72

CHAPTER 5. M171 Performance User Interface	74
5.1. Keys and LEDs	74
5.2. First power on	75
5.3. Menu	75
5.3.1. System Menu	75
5.3.2. BIOS Configuration	76
5.3.3. BIOS I/O Values	76
5.3.4. BIOS RTC Values.....	77
5.3.5. USB-Host Handling	77
CHAPTER 6. M171 Performance Display Graphic user interface.....	82
6.1. Keys and LEDs	82
6.2. First power on	83
6.3. DIAGNOSTICS menu	84
6.3.1. BIOS parameters.....	84
6.3.2. HMI Management.....	84
6.4. Remote interface.....	84
6.4.1. Language	84
6.4.2. ⬆⬇	84
6.4.3. HMI Management.....	85
CHAPTER 7. M171 Performance Flush user interface.....	86
7.1. Keys and LEDs	86
7.2. First power on	87
7.3. DIAGNOSTIC menu	88
7.3.1. BIOS parameters.....	88
7.3.2. HMI management.....	88
7.3.3. Probe values	88
7.3.4. Date and time	89
7.4. Remote interface.....	90
7.4.1. Language	90
7.4.2. ⬆⬇	90
7.4.3. HMI sel	90
7.4.4. COM Setting.....	91
7.4.5. HMI Management.....	91

CHAPTER	8. Physical I/O and ports configuration	92
	8.1. Analog inputs.....	93
	8.1.1. Analog inputs configuration for M171 Performance	93
	8.1.2. Analog inputs configuration for M171EP14R.....	94
	8.1.3. Analog inputs configuration for M171 Performance Flush.....	96
	8.2. Analog outputs configuration for M171 Performance	97
	8.3. Digital inputs configuration for M171 Performance	97
	8.4. Digital outputs configuration for M171 Performance	97
	8.5. Ports configuration for M171 Performance using DipSwitch.....	98
	8.5.1. TM171PDM27• DipSwitch	99
	8.5.2. TM171PBM27R DipSwitch.....	100
	8.5.3. TM171EP27R expansion DipSwitch	104
	8.5.4. TM171EP14R expansion DipSwitch	106
CHAPTER	9. Parameters	107
	9.1. M171 Performance parameter table	107
	9.1.1. TM171PDM27• / TM171PBM27R / TM171EP27R parameters.....	108
	9.1.2. M171EP14R parameters.....	119
	9.1.3. M171 Performance Flush parameters.....	123
CHAPTER	10. Programming of the TM171EP14R	132

SAFETY INFORMATION



Important Information

Read these instructions carefully, and look at the equipment to become familiar with the device before trying to install, operate, service, or maintain it. The following special messages may appear throughout this documentation or on the equipment to inform of potential hazards or to call attention to information that clarifies or simplifies a procedure.



The addition of this symbol to a Danger safety label indicates that an electrical hazard exists, which will result in personal injury if the instructions are not followed.



This is the safety alert symbol. It is used to alert you to potential personal injury hazards. Obey all safety messages that follow this symbol to avoid possible injury or death.

DANGER

DANGER indicates a hazardous situation which, if not avoided, **will result** in death or serious injury.

WARNING

WARNING indicates a hazardous situation which, if not avoided, **could result** in death or serious injury.

CAUTION

CAUTION indicates a hazardous situation which, if not avoided, **could result** in minor or moderate injury.

NOTICE

NOTICE is used to address practices not related to physical injury.

PLEASE NOTE

Electrical equipment should be installed, operated, serviced, and maintained only by qualified personnel.

No responsibility is assumed by Schneider Electric for any consequences arising out of the use of this material.

A qualified person is one who has skills and knowledge related to the construction and operation of electrical equipment and its installation, and has received safety training to recognize and avoid the hazards involved.

Permitted use

This product is used to control HVAC-related and pumping applications.

For safety reasons, the device must be installed and used in accordance with the instructions provided. In particular, parts carrying dangerous voltages must not be accessible under normal conditions.

The device must be adequately protected from water and dust with regard to the application, and must only be accessible using tools (with the exception of the front panel).

The device is also suitable for use in household and commercial refrigeration appliances and/or similar equipment and has been tested for safety aspects in accordance with the harmonized European reference standards.

Prohibited use

Any use other than that expressed above under Permitted use is strictly prohibited.

The relay contacts supplied are of an electromechanical type and subject to wear. Functional safety protection devices, specified in international or local standards, must be installed externally to this device.

Liability and residual risks

Schneider Electric liability is limited to the proper and professional use of this product under the guidelines contained in the present and other supporting documents, and does not extend to damages caused by (but not limited to):

- Unspecified installation/use and, in particular, in contravention of the safety requirements of established legislation or specified in this document;
- Use on equipment which does not provide adequate protection against electrocution, water and dust in the actual installation conditions;
- Use on equipment in which dangerous components can be accessed without the use of specific tools;
- Installation/use on equipment which does not comply with established legislation and standards.

Disposal



The appliance (or the product) must be disposed of separately in compliance with the local standards in force on waste disposal.

Product Related Information

DANGER

HAZARD OF ELECTRIC SHOCK, EXPLOSION OR ARC FLASH

- Disconnect all power from all equipment including connected devices prior to removing any covers or doors, or installing or removing any accessories, hardware, cables, or wires.
- Always use a properly rated voltage sensing device to confirm the power is removed.
- Replace and secure all covers, accessories, hardware, cables, and wires and confirm that a proper ground connection exists before applying power to the unit.
- Use only the specified voltage when operating this equipment and any associated products.

Failure to follow these instructions will result in death or serious injury.

This equipment has been designed to operate outside of any hazardous location.
Only install this equipment in zones known to be free of hazardous atmosphere.

DANGER

POTENTIAL FOR EXPLOSION

Install and use this equipment in non-hazardous locations only.

Failure to follow these instructions will result in death or serious injury.

WARNING

LOSS OF CONTROL

- The designer of any control scheme must consider the potential failure modes of control paths and, for certain critical control functions, provide a means to achieve a safe state during and after a path failure. Examples of critical control functions are emergency stop and overtravel stop, power outage and restart.
- Separate or redundant control paths must be provided for critical control functions.
- System control paths may include communication links. Consideration must be given to the implications of unanticipated transmission delays or failures of the link.
- Observe all accident prevention regulations and local safety guidelines.⁽¹⁾
- Each implementation of this equipment must be individually and thoroughly tested for proper operation before being placed into service.

Failure to follow these instructions can result in death, serious injury, or equipment damage.

(1) For additional information, refer to NEMA ICS 1.1 (latest edition), "Safety Guidelines for the Application, Installation, and Maintenance of Solid State Control" and to NEMA ICS 7.1 (latest edition), "Safety Standards for Construction and Guide for Selection, Installation and Operation of Adjustable-Speed Drive Systems" or their equivalent governing your particular location.

WARNING

UNINTENDED EQUIPMENT OPERATION

- Only use software approved by Schneider Electric for use with this equipment.
- Update your application program every time you change the physical hardware configuration.

Failure to follow these instructions can result in death, serious injury, or equipment damage.

ABOUT THE BOOK



Document Scope

This document describes the **Modicon M171 performance logic controllers** and accessories including installation and wiring information.

Use this document to:

- Install and operate your **Modicon M171 Performance logic controller**.
- Connect the **Modicon M171 Performance logic controller** to a programming device equipped with **SoMachine HVAC** software.
- Interface the **Modicon M171 Performance logic controller** with I/O expansion modules, HMI and other devices.
- Familiarize yourself with the **Modicon M171 Performance logic controller** features.

NOTE: Read and understand this document and the related documents before installing, operating, or maintaining your controller.

Validity Note

This document is valid for **SoMachine HVAC (v.2.0 or greater)**.

The technical characteristics of the devices described in this manual also appear online.

The characteristics that are presented in this manual should be the same as those characteristics that appear online. In line with our policy of constant improvement, we may revise content over time to improve clarity and accuracy. If you see a difference between the manual and online information, use the online information as your reference.

Related Documents

Title of Documentation	Reference Document Code
Modicon M172 Performance Logic Controller, Hardware User Guide	EIO0000002015 (ENG) EIO0000002017 (GER)
Modicon M171 Optimized Logic Controller, Hardware User Guide	EIO0000002032 (ENG) EIO0000002033 (GER)
Modicon M171 Electronic Expansion Valve Drivers, User Guide	EIO0000002034 (ENG) EIO0000002037 (GER)
SoMachine HVAC Software, Programming Guide	EIO0000002036 (ENG)
SoMachine HVAC HVAC&R Function Library, User Guide	EIO0000002057 (ENG)
TM172 Performance 28/42 IO Instruction Sheet	NH87740
TM171 Performance 27 IO Instruction Sheet	EAV96004
TM171 Performance Flush 3 IO Instruction Sheet	EAV96006
TM171 Performance Communication Instruction Sheet	EAV960007
TM171 Performance Display Instruction Sheet	EAV96014

You can download these technical publications and other technical information from our website at:

www.schneider-electric.com

CHAPTER 1

Introduction

1.1. General description of Modicon M171 Performance

The **Modicon M171P** is a **Schneider Electric** range of programmable controller, suitable for managing a wide range of HVAC/R and many other applications, from the simplest to the most complex.

In this manual, the photos and drawings are intended to show the **Modicon M171 Performance** programmable controller (and other Modicon devices) and are for illustrative purposes only. The relative sizes and proportions may not be indicative of actual dimensions nor to scale. In addition, any wiring diagrams or electrical schematics are to be considered as simplified renditions and not literal representations thereof.

1.1.1. Modicon M171 Performance offer

The **Modicon M171P** offer is made of:

- **M171 Performance**
- **M171 Performance Display Graphic**
- **M171 Performance Flush**

References	Description
TM171PDM27R	M171 Performance Display 27 I/Os, Modbus
TM171PDM27S	M171 Performance Display 27 I/Os Modbus, 2 SSR
TM171PBM27R	M171 Performance Blind 27 I/Os, Modbus
TM171EP27R	M171 Performance expansion 27 I/Os
TM171EP14R	M171 Performance expansion 14 I/Os
TM171DGRP	M171 Performance Display Graphic
TM171PFE03	M171 Performance Flush 3 I/Os, MB & BACnet
TM171PFE03	M171 Performance Flush 3 I/Os, MB & BACnet
TM171PFE03HR	M171 Performance Flush 3 I/Os RH, MB & BACnet

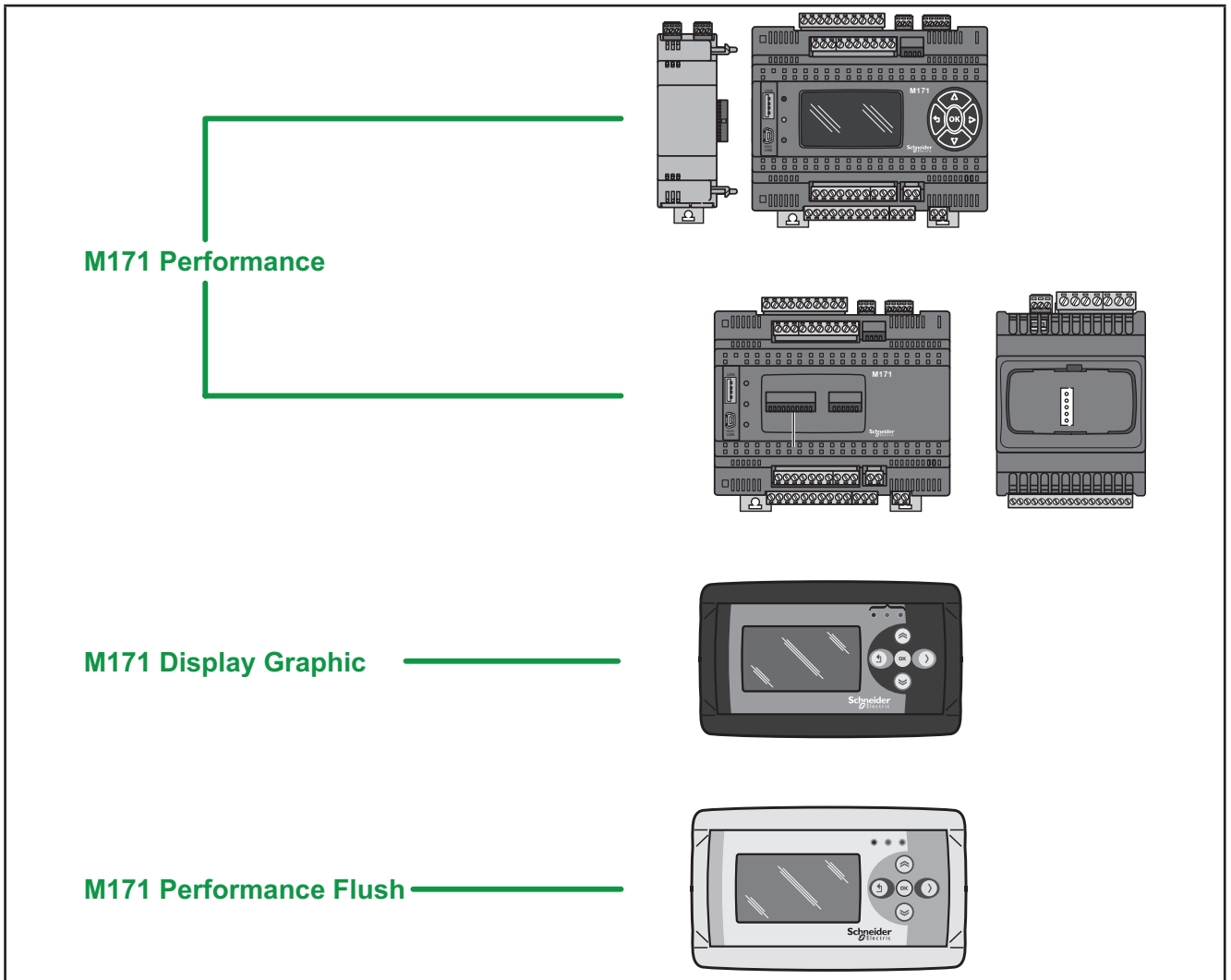

Fig. 1. Modicon M171P

M171 Performance delivers performance in terms of memory, connectivity and user interface as well as straightforward programming, maintenance and servicing.

The references are available as 8DIN rail-mounted versions, which saves time in terms of wiring. The 8DIN format provides extra flexibility and easy installation.

A wide range of 2DIN rail mounted Communication Modules allow integration with industrial systems, BMS and Ethernet networks.

Lastly, ratiometric pressure sensors and displays can also be connected with no need for further serial interfaces.

M171 Performance Flush can be used as a system controller, with gateway functions; used in combination with the **M171 Performance** and the **Modicon M171O** or third-party controllers, it delivers performance in terms of memory, connectivity and user interface as well as straightforward programming, maintenance and servicing.

M171 Performance Flush is designed for panel mounting, and can also be wall-mounted using a special backplate, available as an accessory.

M171 Performance Flush can be used to:

- manage a local menu created with the **TM171SW (SoMachineHVAC)** User Interface;
- manage up to 10 remote menus, created with the **TM171SW (SoMachineHVAC)** User Interface and uploaded from the respective **M171 Performance** devices connected to the network;
- share network variables (binding).

In association with the **Modicon M171P** hardware, there is also the **TM171SW (SoMachineHVAC)** development tool to program and customize new programs for many HVAC- and pumping-related applications.

The use of several different programming languages in accordance with IEC61131-3 regulations makes it possible to develop new algorithms or programs, which can then be uploaded to the **Modicon M171P** modules via PC or (only for DIN rail mounted Performance controllers) USB memory key.

Web functionalities

The **Modicon M171 Performance** also features web functionalities, offering makers of machinery and systems integrators remote access. Having a web-based connection in machines reduces support and maintenance by minimizing call-out charges. End users also benefit, as they can monitor their own systems both locally and from distance, using the graphics interface of any browser.

Main web functionalities

- Web-based access.
- Remote reading and support.
- Local and remote system control, including alarms management.
- Preventive and predictive maintenance.
- Email alarm alerts.

Care must be taken and provisions made for use of this product as a control device to avoid inadvertent consequences of commanded machine operation, controller state changes, or alteration of data memory or machine operating parameters.

WARNING

UNINTENDED EQUIPMENT OPERATION

- Configure and install the mechanism that enables the remote HMI local to the machine, so that local control over the machine can be maintained regardless of the remote commands sent to the application.
- You must have a complete understanding of the application and the machine before attempting to control the application remotely.
- Take the precautions necessary to assure that you are operating remotely on the intended machine by having clear, identifying documentation within the application and its remote connection.

Failure to follow these instructions can result in death, serious injury, or equipment damage.

CHAPTER 2

Mechanical installation

2.1. Before Starting

Read and understand this chapter before beginning the installation of your system. The use and application of the information contained herein require expertise in the design and programming of automated control systems. Only you, the user, machine builder or integrator, can be aware of all the conditions and factors present during installation and setup, operation, and maintenance of the machine or process, and can therefore determine the automation and associated equipment and the related safeties and interlocks which can be effectively and properly used. When selecting automation and control equipment, and any other related equipment or software, for a particular application, you must also consider any applicable local, regional or national standards and/or regulations. Pay particular attention in conforming to any safety information, different electrical requirements, and normative standards that would apply to your machine or process in the use of this equipment.

WARNING

REGULATORY INCOMPATIBILITY

Be sure that all equipment applied and systems designed comply with all applicable local, regional and national regulations and standards.

Failure to follow these instructions can result in death, serious injury, or equipment damage.

2.2. Disconnecting Power

All options and modules should be assembled and installed before installing the control system on a mounting rail, into a panel door or onto a mounting surface. Remove the control system from its mounting rail, mounting plate or panel before disassembling the equipment.

DANGER

HAZARD OF ELECTRIC SHOCK, EXPLOSION OR ARC FLASH

- Disconnect all power from all equipment including connected devices prior to removing any covers or doors, or installing or removing any accessories, hardware, cables, or wires.
- Always use a properly rated voltage sensing device to confirm the power is removed.
- Replace and secure all covers, accessories, hardware, cables, and wires and confirm that a proper ground connection exists before applying power to the unit.
- Use only the specified voltage when operating this equipment and any associated products.

Failure to follow these instructions will result in death or serious injury.

2.3. Programming Considerations

The products described in this manual have been designed and tested using Schneider Electric programming, configuration and maintenance software products.

WARNING

UNINTENDED EQUIPMENT OPERATION

- Only use software approved by Schneider Electric for use with this equipment.
- Update your application program every time you change the physical hardware configuration.

Failure to follow these instructions can result in death, serious injury, or equipment damage.

2.4. Operating Environment

This equipment has been designed to operate outside of any hazardous location. Only install this equipment in zones known to be free of a hazardous atmosphere.

DANGER

POTENTIAL FOR EXPLOSION

Install and use this equipment in non-hazardous locations only.

Failure to follow these instructions will result in death or serious injury.

WARNING

UNINTENDED EQUIPMENT OPERATION

Install and operate this equipment according to the conditions described in the General Specifications.

Failure to follow these instructions can result in death, serious injury, or equipment damage.

2.5. Installation Considerations

WARNING

UNINTENDED EQUIPMENT OPERATION

- Use appropriate safety interlocks where personnel and/or equipment hazards exist.
- Install and operate this equipment in an enclosure appropriately rated for its intended environment.
- Power line and output circuits must be wired and fused in compliance with local and national regulatory requirements for the rated current and voltage of the particular equipment.
- Do not use this equipment in safety-critical machine functions.
- Do not disassemble, repair, or modify this equipment.
- Do not connect any wiring to reserved, unused connections, or to connections designated as No Connection (N.C.).
- Do not mount devices in extremely damp and/or dirt-laden areas.

Failure to follow these instructions can result in death, serious injury, or equipment damage.

NOTE: JDYX2 or JDYX8 fuse types are UL-recognized and CSA approved.

For mechanical dimensions, see [4.6. Mechanical dimensions on page 72](#).

The **Modicon M171P** logic controllers are intended for DIN rail mounting, panel mounting or wall mounting.

Care must be taken to avoid damage from electrostatic sources when handling this equipment. In particular exposed connectors and, in some cases, exposed printed circuit boards are vulnerable to electrostatic discharge.

⚠ WARNING

UNINTENDED EQUIPMENT OPERATION DUE TO ELECTROSTATIC DISCHARGE DAMAGE

- Keep equipment in the protective conductive packaging until you are ready to install the equipment.
- Only install equipment in approved enclosures and / or locations that prevent casual access and provide electrostatic discharge protection as defined by IEC 1000-4-2.
- Use a conductive wrist strap or equivalent field force protective device attached to an earth ground when handling sensitive equipment.
- Always discharge yourself by touching a grounded surface or approved antistatic mat before handling the equipment.

Failure to follow these instructions can result in death, serious injury, or equipment damage.

2.6. TM171PDM27● / TM171PBM27R / TM171EP●●R installation

The equipment is intended for 8DIN rail mounting (refer to **Fig. 2 on page 18** and **Fig. 3 on page 19**).
For DIN rail installation, follow the steps described below:

1. Move the two clip-on locks to their standby position (use a screwdriver to press against the relative compartments).
2. Install the device on the DIN rail.
3. Press on the clip-on locks to put them into the locked position.
4. Once assembled on the DIN rail, the clip-on locks must be turned downwards.

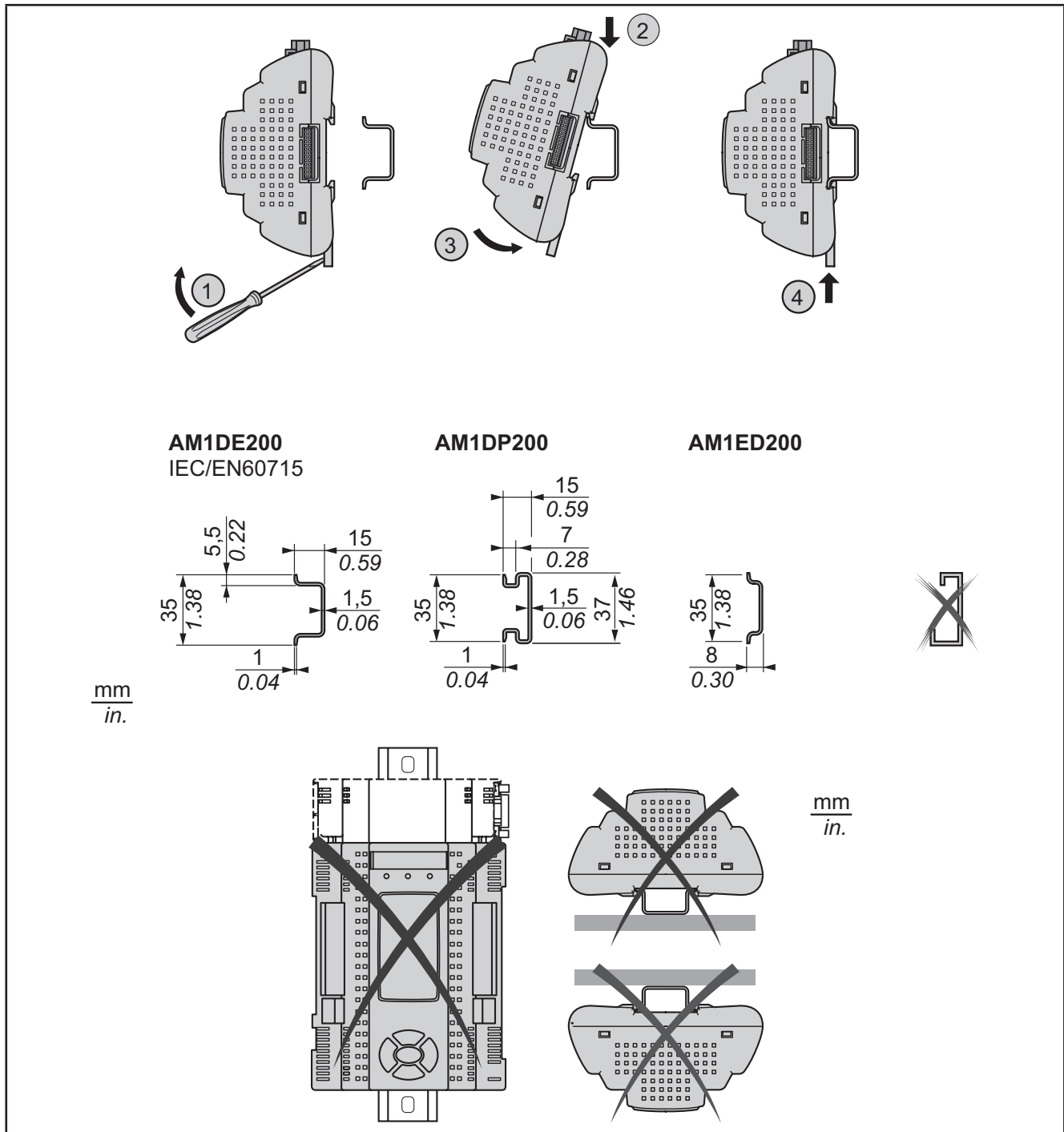

Fig. 2. Mounting

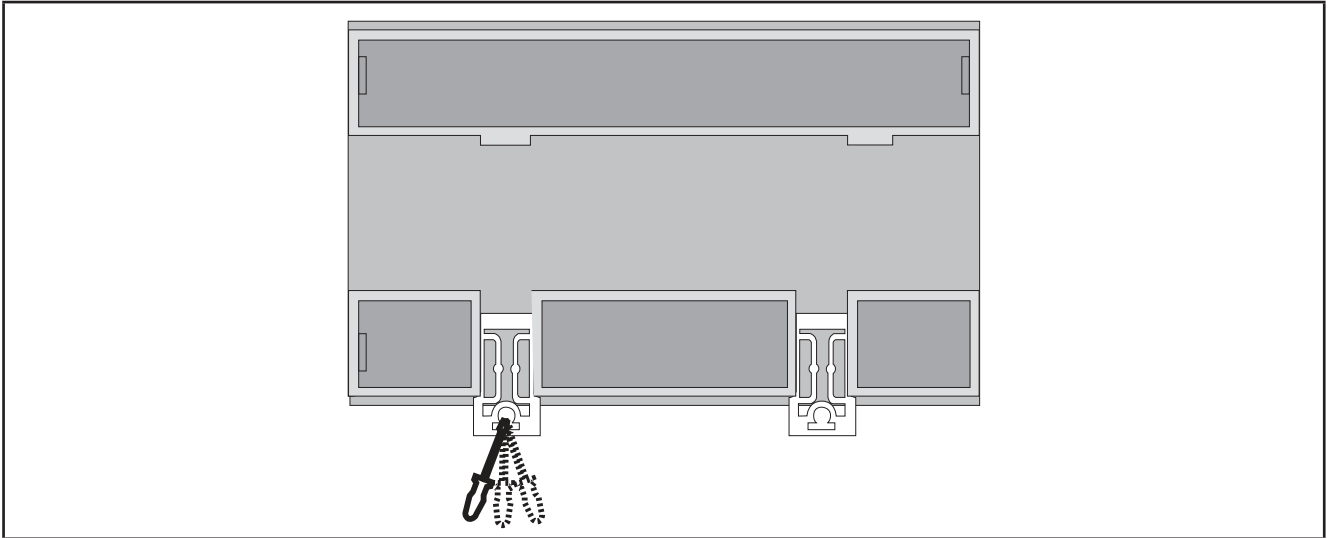

Fig. 3. Details of clip-on locks

The **M171 Performance logic controller** has been designed as an IP20 product and must be installed in an enclosure. Clearances must be respected when installing the product.

There are 3 types of clearances between:

- The **M171P** and all sides of the cabinet (including the panel door).
- The **M171P** terminal blocks and the wiring ducts. This distance reduces electromagnetic interference between the controller and the wiring ducts.
- The **M171P** and other heat generating devices installed in the same cabinet.

⚠ WARNING

UNINTENDED EQUIPMENT OPERATION

- Place devices dissipating the most heat at the top of the cabinet and ensure adequate ventilation.
- Avoid placing this equipment next to or above devices that might cause overheating.
- Install the equipment in a location providing the minimum clearances from all adjacent structures and equipment as directed in this document.
- Install all equipment in accordance with the specifications in the related documentation.

Failure to follow these instructions can result in death, serious injury, or equipment damage.

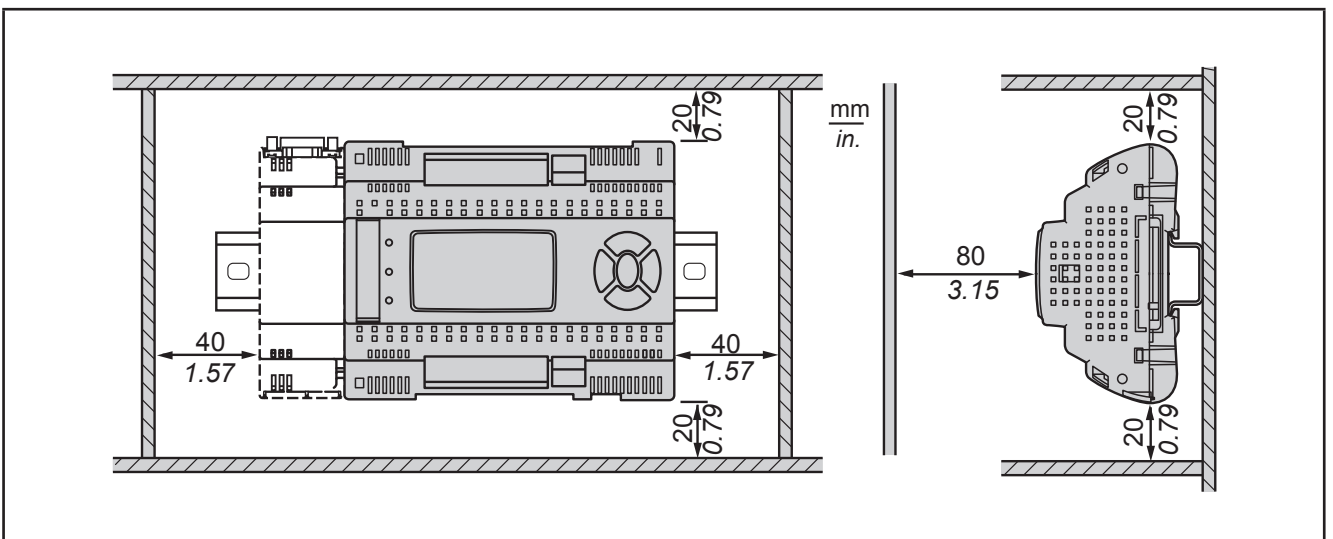

Fig. 4. Clearances

2.7. Assembling the TM171A●●●● Communication Modules

Communication Modules are 2DIN modules that connect to an **M171 Performance TM171PDM27● / TM171PBM27R** controller (refer to **Fig. 5 on page 20** and **Fig. 6 on page 20**).

To assemble **TM171A●●●●** to **TM171PDM27● / TM171PBM27R**, follow the steps described below:

1. Remove the door (if present) on the left side of the **TM171PDM27● / TM171PBM27R** controller by using fingers or a screw-driver.
2. Anchor **TM171A●●●●** to the **TM171PDM27● / TM171PBM27R** controller.
 - via the plug-in connector, behind the removable door.
 - with the fixing screws to which the Communication Module is anchored to.

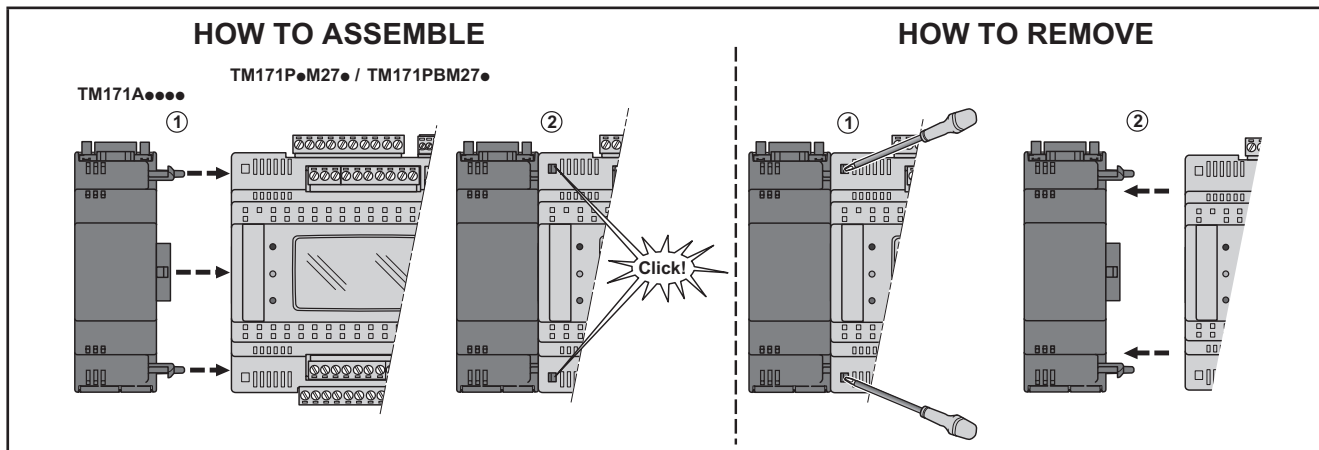

Fig. 5. Assembling the TM171A●●●● Communication Modules

Follow the instructions below to install it on DIN rail:

1. Move the clip-on locks (two for **TM171PDM27● / TM171PBM27R**, one for **TM171A●●●●**) to its standby position (use a screwdriver).
2. Install **TM171PDM27● / TM171PBM27R + TM171A●●●●** on the DIN rail.
3. Press the clip-on locks which will go to the closing position.
4. Once the "BASE" is mounted on the DIN rail, the clip-on locks must be turned downwards.

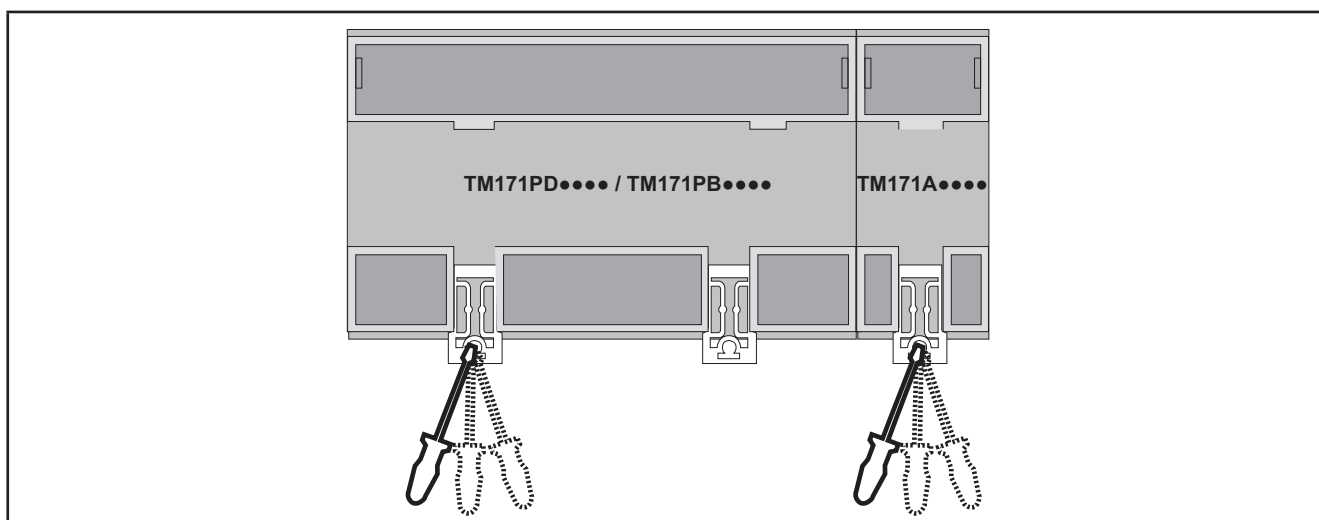

Fig. 6. Details of clip-on locks

2.8. Assembling the M171 Performance Flush or TM171DGRP

2.8.1. Panel mounting

The equipment is intended for panel mounting (refer to [Fig. 7 on page 21](#)).

The following figures show **M171 Performance Flush** mounting; same steps are required for **M171 Performance Display Graphic (TM171DGRP)** mounting.

For panel mounting, follow the steps described below:

1. Cut from the panel a 138 x 68 mm rectangular opening.
2. Drill, at the specified spacing, 4 holes in the panel that the controller is to be mounted on or two holes, of diameter 2.7 mm.
3. Insert the device, fixing it with the screws.
4. Press the front of the **M171 Performance Flush** to close.

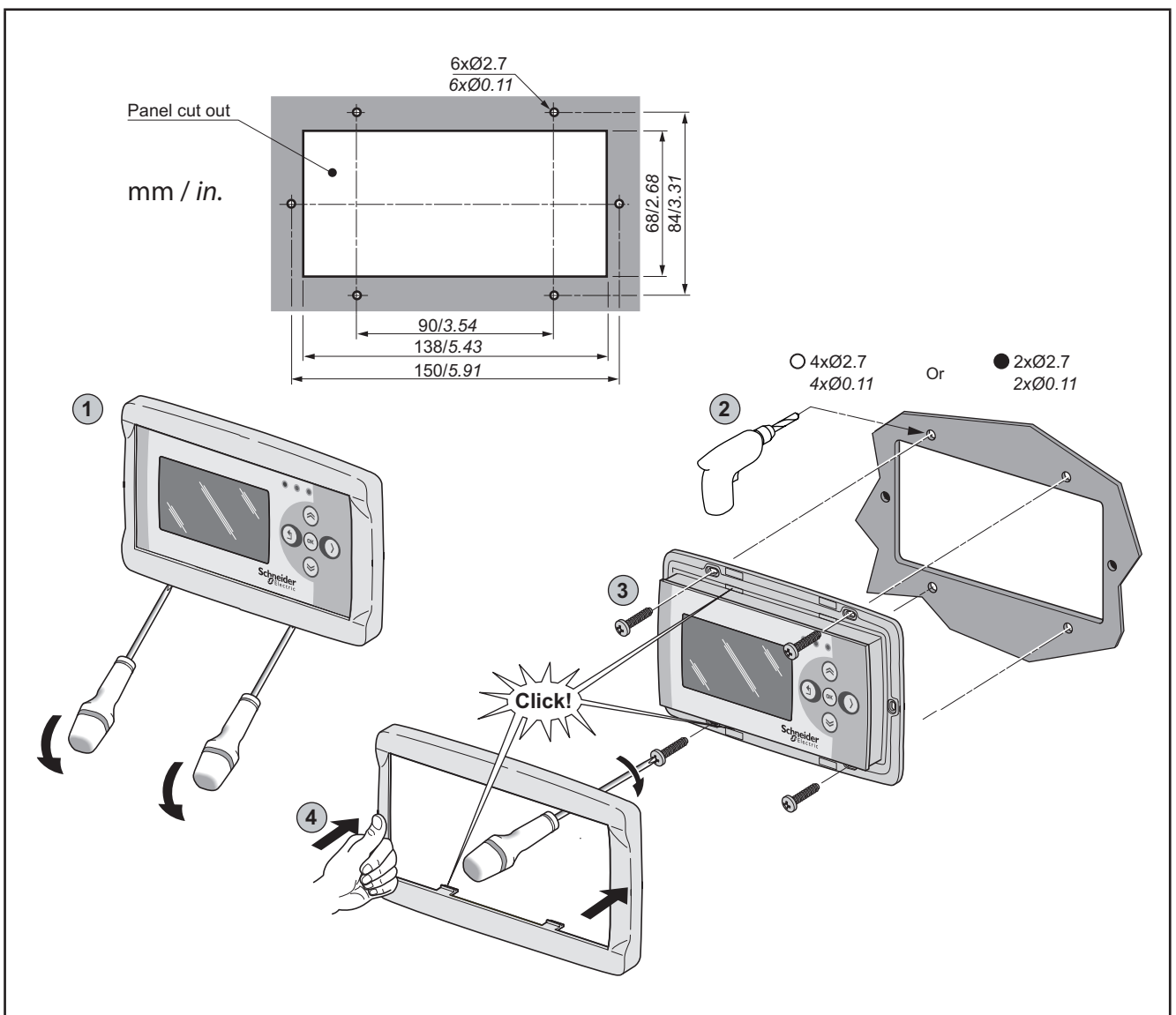

Fig. 7. Assembling the M171 Performance Display Graphic (TM171DGRP) or M171 Performance Flush display

2.8.2. Accessories for Wall mounting

The equipment is also intended for wall mounting (refer to **Fig. 8 on page 22**).
Contact the **Schneider Electric Sales Department** for wall-mounting accessories.

1. Drill 4 holes of diameter 4.2 mm in the wall at the specified spacing to fix the backplate.
2. Use the two side slots, one at the bottom and one at the top, under the pre-formatted removable doors, preventing the opening of holes in the wall.
3. Insert the backplate, fixing it with the screws.
4. Insert the device, fixing it with the screws.
5. Press the front of the **M171 Performance Flush** to close.

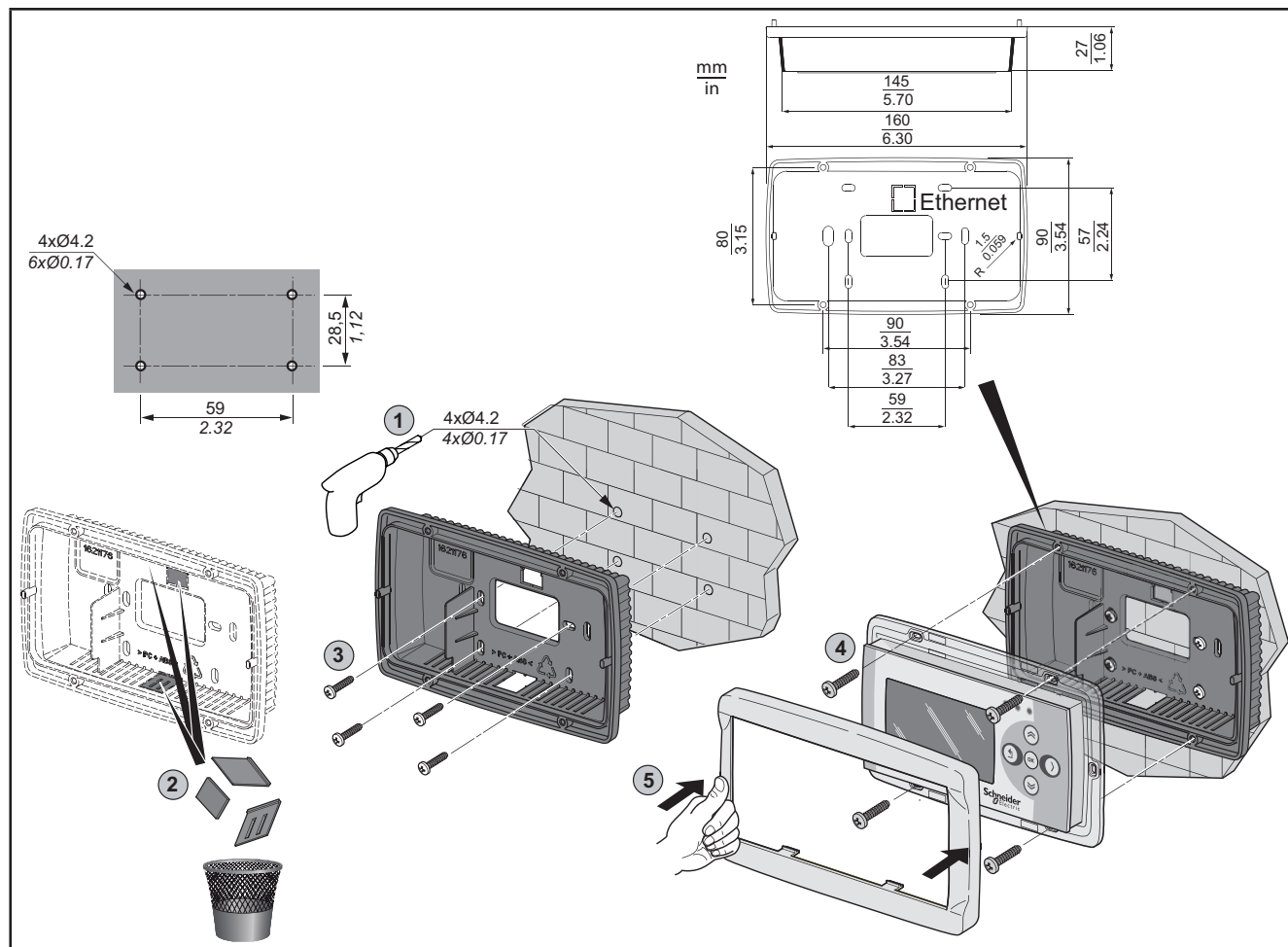

Fig. 8. Accessories for Wall mounting

Reference	Description
TM171ABKPB	White backplate kit for wall mounting
TM171ABKPG	Black backplate kit for wall mounting

4 backplates per package.

CHAPTER 3

Electrical connections

3.1. Wiring Best Practices

The following information describes the wiring guidelines and associated best practices to be respected when using the **M171 Performance Logic Controller**.

DANGER

HAZARD OF ELECTRIC SHOCK, EXPLOSION OR ARC FLASH

- Disconnect all power from all equipment including connected devices prior to removing any covers or doors, or installing or removing any accessories, hardware, cables, or wires.
- Always use a properly rated voltage sensing device to confirm the power is removed.
- Replace and secure all covers, accessories, hardware, cables, and wires and confirm that a proper ground connection exists before applying power to the unit.
- Use only the specified voltage when operating this equipment and any associated products.

Failure to follow these instructions will result in death or serious injury.

WARNING

LOSS OF CONTROL

- The designer of any control scheme must consider the potential failure modes of control paths and, for certain critical control functions, provide a means to achieve a safe state during and after a path failure. Examples of critical control functions are emergency stop and overtravel stop, power outage and restart.
- Separate or redundant control paths must be provided for critical control functions.
- System control paths may include communication links. Consideration must be given to the implications of unanticipated transmission delays or failures of the link.
- Observe all accident prevention regulations and local safety guidelines.⁽¹⁾
- Each implementation of this equipment must be individually and thoroughly tested for proper operation before being placed into service.

Failure to follow these instructions can result in death, serious injury, or equipment damage.

⁽¹⁾ For additional information, refer to NEMA ICS 1.1 (latest edition), “Safety Guidelines for the Application, Installation, and Maintenance of Solid State Control” and to NEMA ICS 7.1 (latest edition), “Safety Standards for Construction and Guide for Selection, Installation and Operation of Adjustable-Speed Drive Systems” or their equivalent governing your particular location.

3.1.1. Wiring Guidelines

The following rules must be applied when wiring a **M171 Performance logic controllers**:

- I/O and communication wiring must be kept separate from the power wiring. Route these two types of wiring in separate cable ducting.
- Verify that the operating conditions and environment are within the specification values.
- Use proper wire sizes to meet voltage and current requirements.
- Use copper conductors (required).
- Use twisted pair, shielded cables for analog, and/or fast I/O.
- Use twisted pair, shielded cables for networks, and fieldbus.

Use shielded, properly grounded cables for all analog and high-speed inputs or outputs and communication connections. If you do not use shielded cable for these connections, electromagnetic interference can cause signal degradation. Degraded signals can cause the controller or attached modules and equipment to perform in an unintended manner.

⚠ WARNING

UNINTENDED EQUIPMENT OPERATION

- Use shielded cables for all fast I/O, analog I/O and communication signals.
- Ground cable shields for all analog I/O, fast I/O and communication signals at a single point ⁽¹⁾.
- Route communication and I/O cables separately from power cables.
- Make connections as short as possible and do not wind them around electrically connected parts.







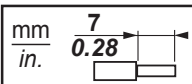

Failure to follow these instructions can result in death, serious injury, or equipment damage.

⁽¹⁾ Multipoint grounding is permissible if connections are made to an equipotential ground plane dimensioned to help avoid cable shield damage in the event of power system short-circuit currents.

NOTE: Surface temperatures may exceed 60 °C. Route primary wiring (wires connected to power mains) separately and apart from secondary wiring (extra low voltage wiring coming from intervening power sources). If that is not possible, double insulation is required such as conduit or cable gains.

3.1.2. Rules for Removable Screw Terminal Block

The following table presents the cable types and wire sizes for a **5.08** or **5.00** pitch removable screw terminal block:

								
mm ²	0.2...2.5	0.2...2.5	0.25...2.5	0.25...2.5	2 x 0.2...1	2 x 0.2...1.5	2 x 0.25...1	2 x 0.5...1.5
AWG	24...14	24...14	22...14	22...14	2 x 24...18	2 x 24...16	2 x 22...18	2 x 20...16









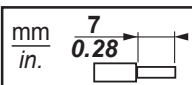

 Ø 3,5 mm (0.14 in.)		N•m lb-in	0.5...0.6 4.42...5.31
--	---	--------------	--------------------------

Fig. 9. Pitch 5.08 mm (0.20 in.) or 5.00 mm (0.197 in.)

The following table presents the cable types and wire sizes for a **3.81** or **3.50** pitch removable screw terminal block:

								
mm ²	0.2...2.5	0.2...2.5	0.25...2.5	0.25...2.5	2 x 0.2...1	2 x 0.2...1.5	2 x 0.25...1	2 x 0.5...1.5
AWG	24...14	24...14	22...14	22...14	2 x 24...18	2 x 24...16	2 x 22...18	2 x 20...16



 Ø 3,5 mm (0.14 in.)		N•m lb-in	0.5...0.6 4.42...5.31
--	---	--------------	--------------------------

Fig. 10. Pitch 3.81 mm (0.15 in.) or 3.50 mm (0.14 in.)

⚡ ⚠ DANGER

LOOSE WIRING CAUSES ELECTRIC SHOCK

Tighten connections in conformance with the torque specifications.

Failure to follow these instructions will result in death or serious injury.

⚠ DANGER

FIRE HAZARD

- Use only the correct wire sizes for the current capacity of the I/O channels and power supplies.
- For 2 A - relay output wiring, use conductors with a cross section at least equal to 0.5 mm² (AWG 20) and a temperature rating at least equal to 80 °C (176 °F).
- For 3 A - relay output wiring, use conductors with a cross section at least equal to 1.5 mm² (AWG 16) and a temperature rating at least equal to 80 °C (176 °F).
- For common conductors of 8 A - relay output wiring, or greater than 3 A - relay output wiring, use conductors with a cross section at least equal to 2.0 mm² (AWG 12) and a temperature rating at least equal to 80 °C (176 °F).

Failure to follow these instructions will result in death or serious injury.

3.1.3. Protecting Outputs from Inductive Load Damage

If your controller or module contains relay outputs, these types of outputs can support up to 250 Vac (240 Vac if SSR). Inductive damage to these types of outputs can result in welded contacts and loss of control. Each inductive load must include a protection device such as a peak limiter, RC circuit or flyback diode. Capacitive loads are not supported by these relays.

⚠ WARNING

RELAY OUTPUTS WELDED CLOSED

- Always protect relay outputs from inductive alternating current load damage using an appropriate external protective circuit or device.
- Do not connect relay outputs to capacitive loads.

Failure to follow these instructions can result in death, serious injury, or equipment damage.

Depending on the load, a protection circuit may be needed for the outputs on the controllers and certain modules. Inductive loads using DC voltages may create voltage reflections resulting in overshoot that will damage or shorten the life of output devices.

⚠ CAUTION

OUTPUT CIRCUIT DAMAGE DUE TO INDUCTIVE LOADS

Use an appropriate external protective circuit or device to reduce the risk of inductive direct current load damage

Failure to follow these instructions can result in injury or equipment damage.

Choose a protection circuit from the following diagrams according to the power supply used. Connect the protection circuit to the outside of the controller or relay output module.

Protective circuit A: this protection circuit can be used for both AC and DC load power circuits.

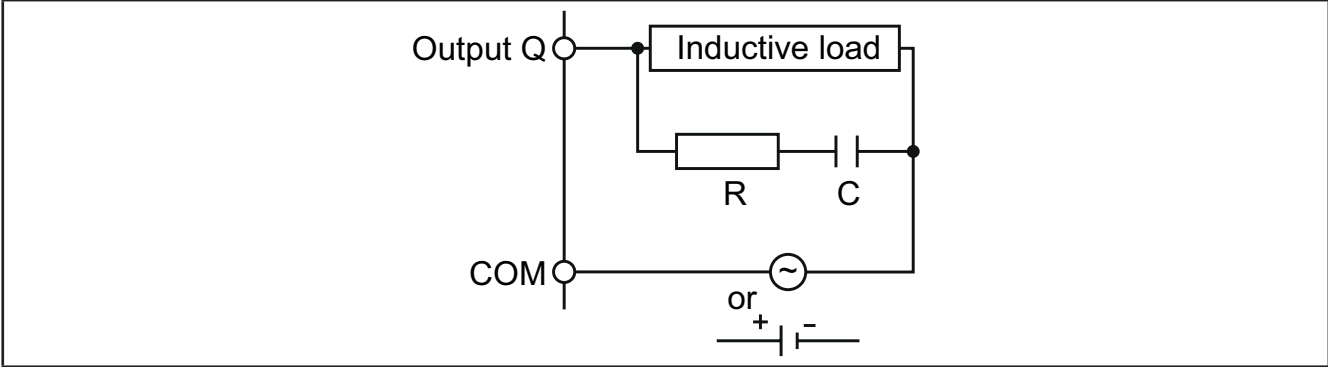

Fig. 11. Protective circuit A

C Value from 0.1 to 1 μ F

R Resistor of approximately the same resistance value as the load

Protective circuit B: this protection circuit can be used for DC load power circuits.

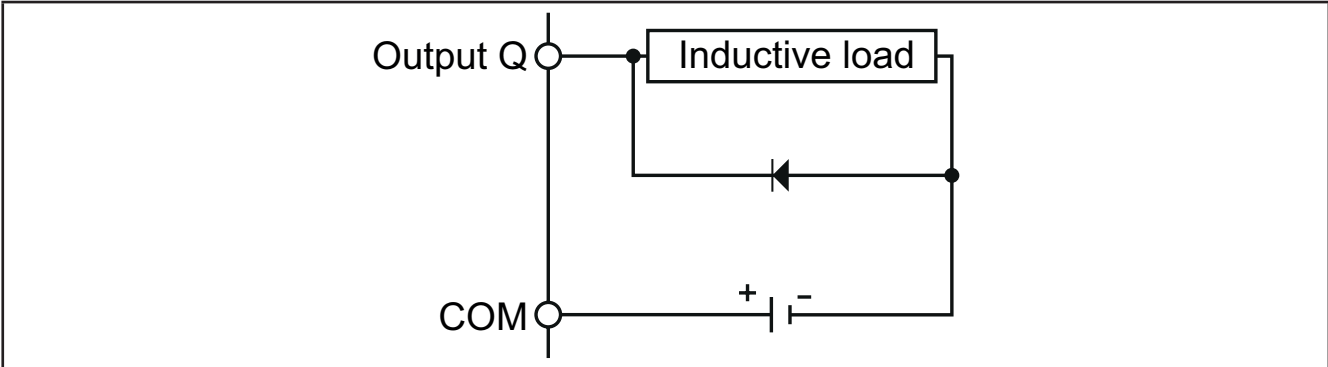

Fig. 12. Protective circuit B

Use a diode with the following ratings:

- Reverse withstand voltage: power voltage of the load circuit x 10.
- Forward current: more than the load current.

Protective circuit C: this protection circuit can be used for both AC and DC load power circuits.

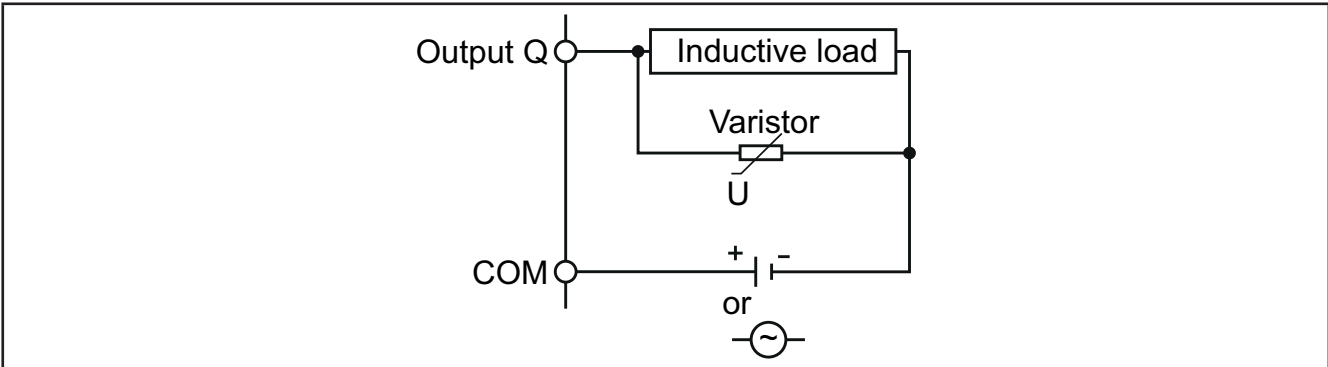

Fig. 13. Protective circuit C

In applications where the inductive load is switched on and off frequently and/or rapidly, ensure that the continuous energy rating (J) of the varistor exceeds the peak load energy by 20 % or more.

NOTE: Place protection devices as close to the load as possible.

3.1.4. Special handling considerations

Care must be taken to avoid damage from electrostatic sources when handling this equipment. In particular exposed connectors and, in some cases, exposed printed circuit boards are vulnerable to electrostatic discharge.

⚠ WARNING
<p>UNINTENDED EQUIPMENT OPERATION DUE TO ELECTROSTATIC DISCHARGE DAMAGE</p> <ul style="list-style-type: none"> • Keep equipment in the protective conductive packaging until you are ready to install the equipment. • Only install equipment in approved enclosures and / or locations that prevent unauthorized access and provide electrostatic discharge protection as defined by IEC 1000-4-2. • Use a conductive wrist strap or equivalent field force protective device attached to an earth ground when handling sensitive equipment. • Always discharge yourself by touching a grounded surface or approved antistatic mat before handling the equipment. <p>Failure to follow these instructions can result in death, serious injury, or equipment damage.</p>

3.1.5. Analog Inputs-Probes

Temperature probes have no connection polarity and can be extended using a normal bipolar cable.

⚠ WARNING
<p>UNINTENDED EQUIPMENT OPERATION DUE TO CONNECTION</p> <ul style="list-style-type: none"> • Apply power to all externally powered devices after applying power to the M171 Performance logic controllers. • Signal leads (probes, digital inputs, communication and the electronic supply) must be routed separately from power cables. <p>Failure to follow these instructions can result in death, serious injury, or equipment damage.</p>

NOTICE
<p>INOPERABLE EQUIPMENT</p> <p>Verify all wiring connections before applying power.</p> <p>Failure to follow these instructions can result in equipment damage.</p>

NOTE: The extension of the probes influences the electromagnetic compatibility (EMC) of the equipment.

NOTE: Connection polarity must be correctly respected for probes which need a specific polarity.

3.1.6. Serial connections

	The reference has on-board serial
M171 Performance	CAN, RS485, USB
M171 Performance Flush	CAN, RS485, ETHERNET

Pay special attention when connecting serial lines. Miswiring may lead to inoperable equipment.

NOTICE
<p>INOPERABLE EQUIPMENT</p> <ul style="list-style-type: none"> • Do not connect equipment that communicate using RS485 serial to CAN terminals. • Do not connect CAN equipment to RS485 terminals. <p>Failure to follow these instructions can result in equipment damage.</p>

Communication Modules **TM171A●●●●** provide additional serial ports for integration with industrial systems, BMS and Ethernet.

Controller serials are defined as "on-board" (OB) whereas serials on **TM171A●●●●** are referred to as Communication Modules (PI, stands for "Plug In").

CAN Expansion Bus

- Use a shielded and **"twisted pair"** cable with two 0.5 mm² section conductors (AWG 22), plus braid such as Belden cable reference 3105A (characteristic impedance 120 Ω) with PVC sleeve, nominal capacity between conductors 36 pF/m, nominal capacity between conductor and shielding 68 pF/m.
- Always follow regulations applicable to the routing and connection of cables. Make certain that data transmission circuits are properly separated from power lines.
- For connections over longer distances, it is better to end the line with resistors on both ends, inserting the two **R TERM** jumpers (available on the terminal strip next to the CAN Expansion Bus as the default configuration).
- The maximum distance depends on the baud setting (see the following table).

kb/s (kbaud)	On-board CAN (m) - M171 Performance	CAN Communication Module (m)
50	1000	1000
125	500	500
250	200	250
500	30	60

- CAN Expansion Bus is used to communicate with **M171 Performance Display Graphic (TM171DGRP)** terminal and **M171 Performance Expansion** terminal.

RS 485

- Use a shielded and **"twisted pair"** cable with two 0.5 mm² section conductors (AWG 22), plus braid such as Belden cable reference 3105A (characteristic impedance 120 Ω) with PVC sleeve, nominal capacity between conductors 36 pF/m, nominal capacity between conductor and shielding 68 pF/m. Alternatively use a shielded and **"twisted pair"** cable with two 0.5 mm² section conductors (AWG 20), plus braid such as Belden cable reference 8762 with PVC sleeve, nominal capacity between conductors 89 pF/m, nominal capacity between conductor and shielding 161 pF/m. See EN 50174 standard on IT cabling for indications on how cables should be routed.
- Always follow regulations applicable to the routing and connection of cables. Make certain that data transmission circuits are properly separated from power lines.
- RS 485 network up to 1200 m in length with a maximum of 32⁽¹⁾ devices can be connected directly to the controller.
 - ⁽¹⁾ Example of **M171 Performance** Modbus Slave with single Master supervisor.
This length can be extended and the number of devices for each channel increased using appropriate repeater modules.
- Single terminal strip with 3 conductors: use all 3 conductors ("+", "-", "GND" for the braid).
- Attach the 120 Ω 1/4 W resistors between the "+" and "-" terminals of the interface and the last controller in each branch of the network.
- Maximum settable speed 115200 baud.
- RS 485 physical layer can be used for Modbus SL, as well as for BACnet MS/TP communication. Concurrent communication of different protocols on the same serial port is **NOT** allowed.

Pay special attention when connecting serial lines. Miswiring may lead to inoperable equipment.

NOTICE

INOPERABLE EQUIPMENT

Do not communicate through Modbus SL and BACnet MS/TP simultaneously on the same line.

Failure to follow these instructions can result in equipment damage.

Ethernet

The Ethernet connection of the Communication Module **TM171AETH / TM171AETHRS485** allows the **M171 Performance** logic controller to communicate on an Ethernet network using TCP/IP protocol, whereas **M171 Performance Flush**, with its embedded Ethernet, does **NOT** require an Ethernet Communication Module.

The connection allows:

- connection of different controllers and/or applications exchanging variables and/or parameters (network).
- connection of a supervision system using Modbus TCP/IP protocol.
- connection of an IEC 61131-3 **TM171SW (SoMachineHVAC)** development system.
- connection on device on a BACnet/TCP network, with B-AAC profile

Concurrent communication on different protocols using the same Ethernet port is allowed.

The Ethernet connector shield is internally connected to the earth of the equipment and therefore to the reference of the input and output channels.

USB

There are 2 USB connectors placed on the upper-left side of the **M171 Performance** controller (in the front view) (see **Fig. 14 on page 29**).

- USB Type A is a connector for USB memory key.
- USB Type mini-B is used for programming purposes.
The components required for **M171 Performance** USB mini-B are: **TCSXCNAMUM3P** or **BMXXCAUSBH018**.

USB	PURPOSE	NOTE
Type A (HOST)	Used to connect a USB memory key when downloading the application. This should be done from the controller keypad (TM171PDM27 references) or from the M171 Performance Display Graphic (TM171DGRP) (TM171PBM27R reference).	See "USB-Host Handling" on 5.3.3. BIOS I/O Values on page 76 for information on how to manage files on USB memory key.
Type mini-B (DEVICE)	Used to connect M171 Performance to a PC via mini-B USB cable for debugging, commissioning, downloading, uploading with TM171SW (SoMachineHVAC v2.0 or greater) . The operations can be done from PC or another device.	Compatible with the following operating systems: <ul style="list-style-type: none"> • Windows Vista Business x86 + x64 (Service Pack 2) • Windows 7 x86 + x64 (Service Pack 1) • Windows 8 / 8.1 x86 + x64 • Windows Server 2008, SP2, and R2 • Windows Server 2012 and R2 <p>The driver is supplied with the TM171SW (SoMachineHVAC v2.0 or greater) software.</p>

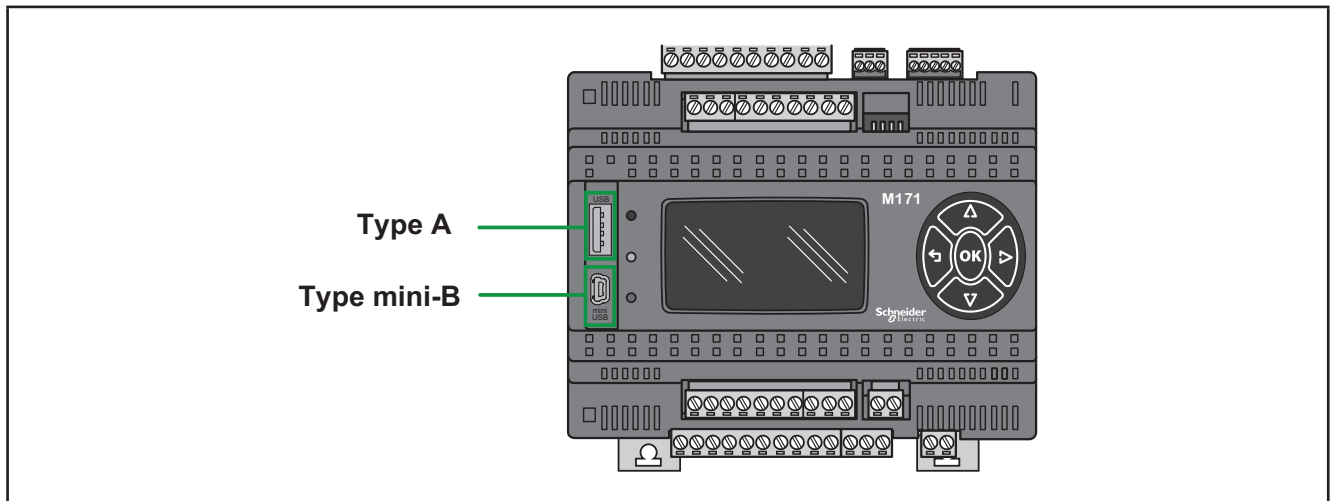

Fig. 14. M171 Performance: type A USB and type mini-B USB

3.2. Wiring diagrams

Miswiring irreversibly damages the **Modicon M171P**.

NOTICE

INOPERABLE EQUIPMENT

Verify all wiring connections before applying power.

Failure to follow these instructions can result in equipment damage.

3.2.1. Modicon M171P wiring diagram

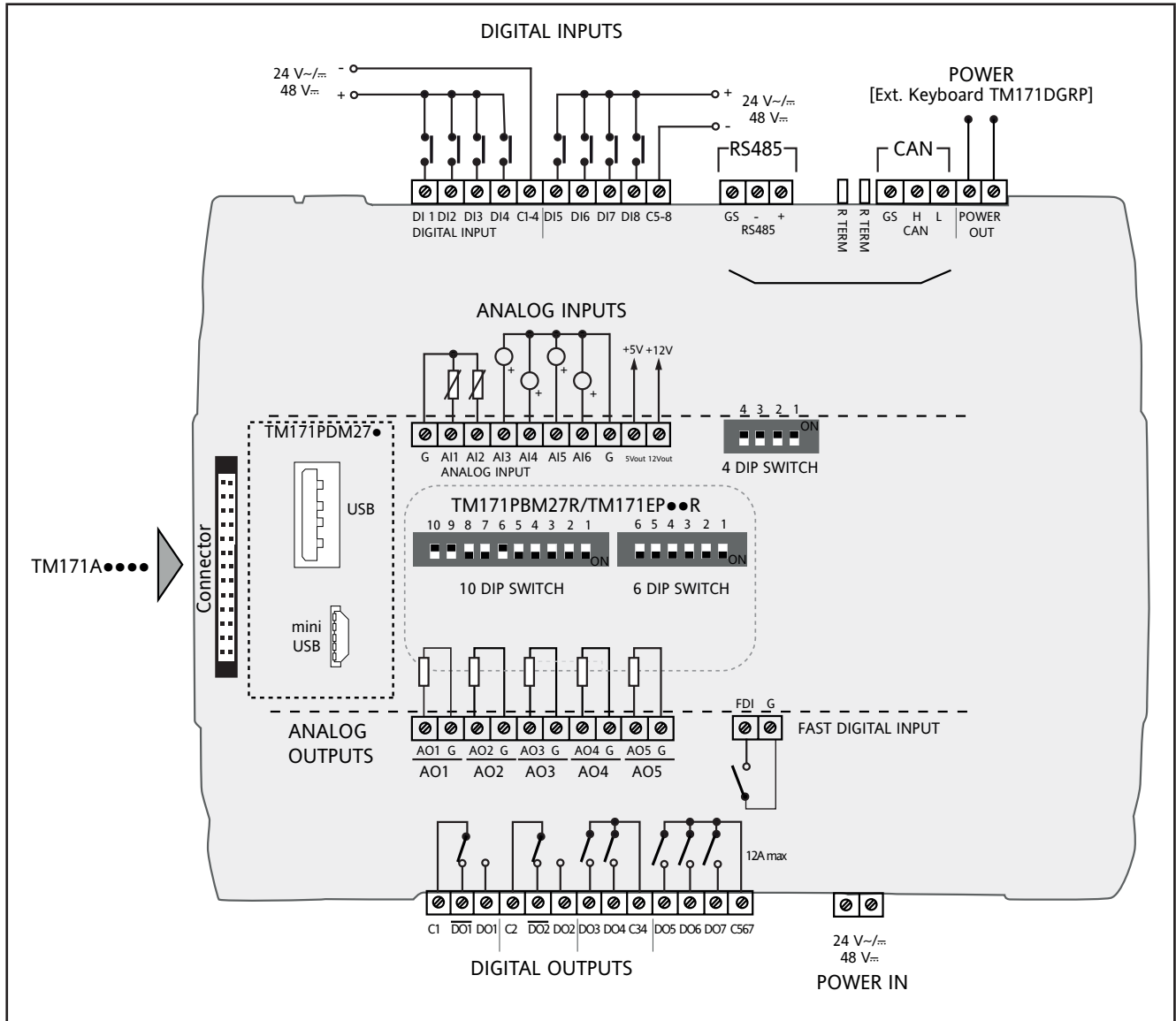

Fig. 15. Modicon M171P wiring diagram

Connector Labels Related To M171 Performance

	LABEL	DESCRIPTION	NOTES
DIP SWITCH	4 DIP SWITCH	4-position selectors (Dip Switches)	Dip Switches default OFF
	6 DIP SWITCH	6-position selectors (Dip Switches)	Dip Switches default OFF TM171PBM27R /TM171EP27R reference Dip Switches located behind the panel
	10 DIP SWITCH	10-position selectors (Dip Switches)	
POWER SUPPLY	POWER IN	+24 Vac/dc or +48 Vdc power supply	-
	POWER OUT	+24 Vac/dc or +48 Vdc power supply	POWER [Ext. Keyboard M171 Performance Display Graphic (TM171DGRP)] output for display
ANALOG OUTPUTS	AO1...AO5	Analog outputs 1...5	See CHAPTER 4 Technical data on page 64 for further details
	G	0 V signal ground	
DIGITAL OUTPUTS	C1 DO1 $\overline{\text{DO1}}$	SPDT Relay 1	DO1 is the normally open side, $\overline{\text{DO1}}$ is the normally closed side
	C2 DO2 $\overline{\text{DO2}}$	SPDT Relay 2	DO2 is the normally open side, $\overline{\text{DO2}}$ is the normally closed side
	DO3 DO4	Relay output 3-4 also available as SSR outputs	-
	C34	Common for digital outputs 3-4	
	DO5 DO6 DO7	Relay output 5-6-7	
	C567	Common for digital outputs 5-6-7	12 A max
CAN	GS H L	Isolated CAN serial GS ground serial isolated from G	R TERM termination resistors for CAN
RS485	GS - +	Isolated RS485 serial GS ground serial isolated from G	Apply 120 Ω termination resistors
DIGITAL INPUTS	DI1...DI4	Digital inputs 1..4	-
	C1-4	Common for digital inputs 1..4	
	DI5...DI8	Digital inputs 5..8	
	C5-8	Common for digital inputs 5..8	
FAST D.I.	FDI	Fast digital input	Pulse/frequency counter up to 1 kHz
	G	0 V signal ground	
ANALOG INPUTS	AI1...AI6	Analog inputs	-
	G	0 V signal ground	
SENSOR POWER SUPPLY	12Vout	12V output for analog inputs	-
	5Vout	5V output for ratiometric analog inputs	

3.2.2. Modicon M171EP14R wiring diagram

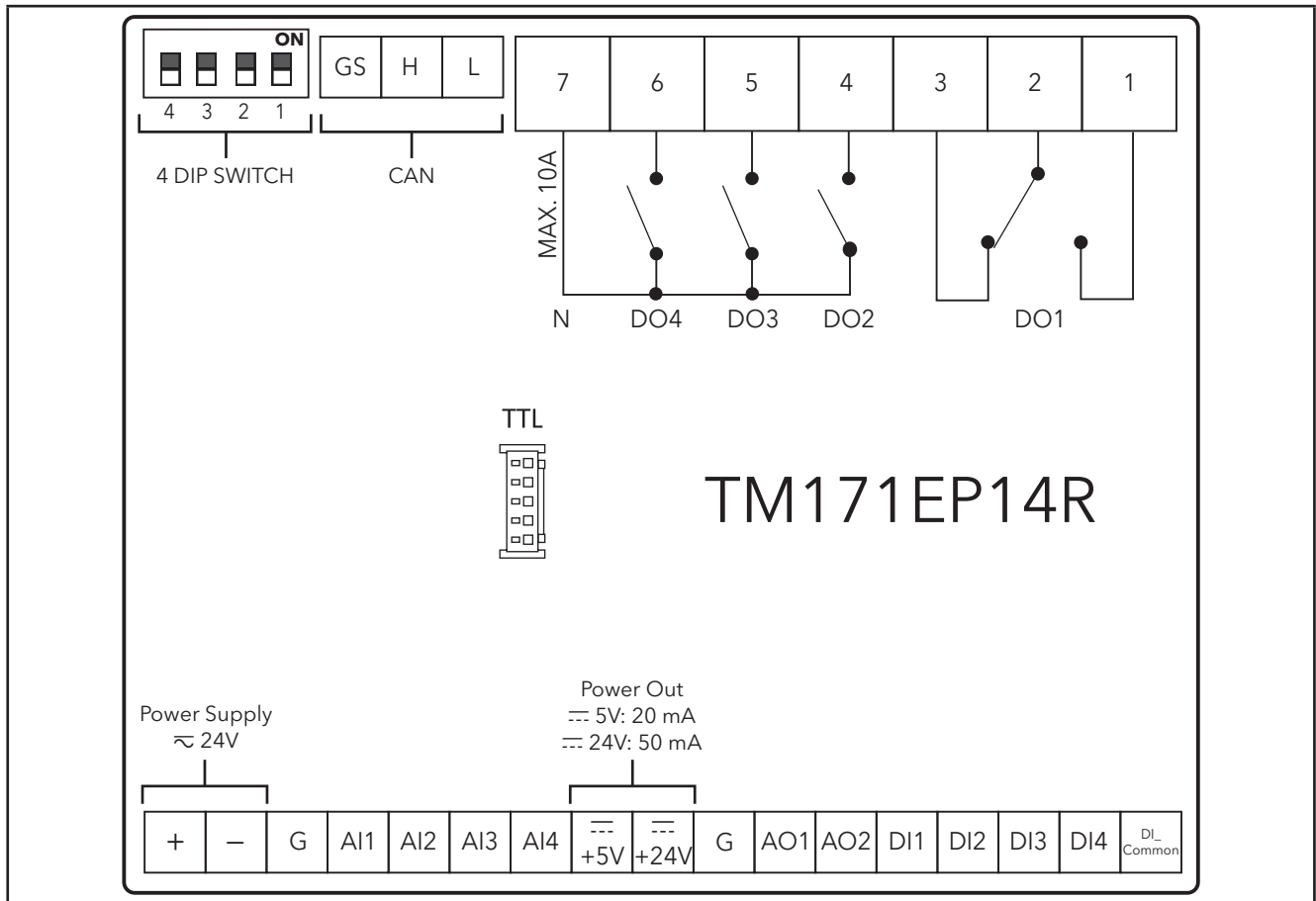

Fig. 16. Modicon M171EP14R wiring diagram

Connector Labels Related To M171EP14R

	LABEL	DESCRIPTION	NOTES
DIP SWITCH	4 DIP SWITCH	4-position selectors (Dip Switches)	Dip Switches default OFF
POWER SUPPLY	+ / -	+24 Vac/dc power supply	-
ANALOG OUTPUTS	AO1, AO2	Analog outputs 1 and 2	See CHAPTER 4 Technical data on page 64 for further details
	G	0 V signal ground	
	+24V	Power Out +24 Vdc output	
	+5V	Power Out +5 Vdc output	
DIGITAL OUTPUTS	1-2-3	SPDT Relay output DO1	1 is the normally open side, 3 is the normally closed side
	4-5-6	SPST Relay output 2-3-4 DO2 DO3 DO4	-
	7	Common for relay outputs 2-3-4 N	10 A max
CAN	GS H L	Isolated CAN serial GS ground serial isolated from G	Dip Switches 3-4 termination resistors for CAN
DIGITAL INPUTS	DI1...DI4	Digital inputs 1...4	-
	DI_Common	Common for digital inputs 1...4	-
ANALOG INPUTS	AI1...AI4	Analog inputs	-
	G	0 V signal ground	-

3.2.3. Examples of analog input connection (M171 Performance only)

Example: NTC/PT1000 probe connection

- Analog inputs AI1...AI6 are available for NTC
- Analog inputs AI3...AI6 are available for NTC/PT1000

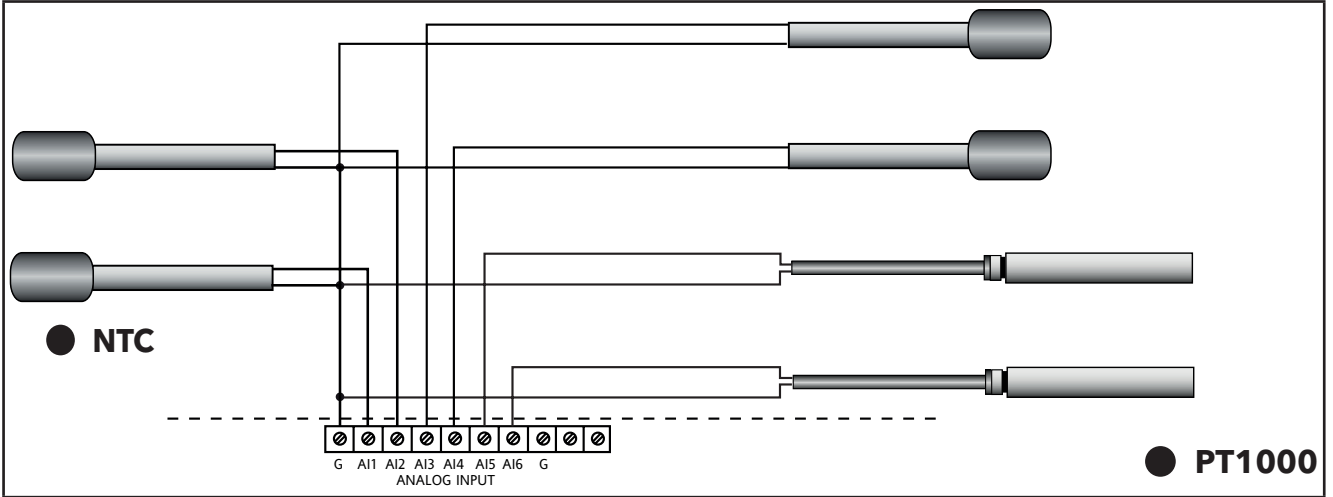

Fig. 17. NTC/PT1000 probe connection

Example: 0-10 V transducer connection

Analog Inputs AI3...AI6 are available for 0-10 V transducer connection

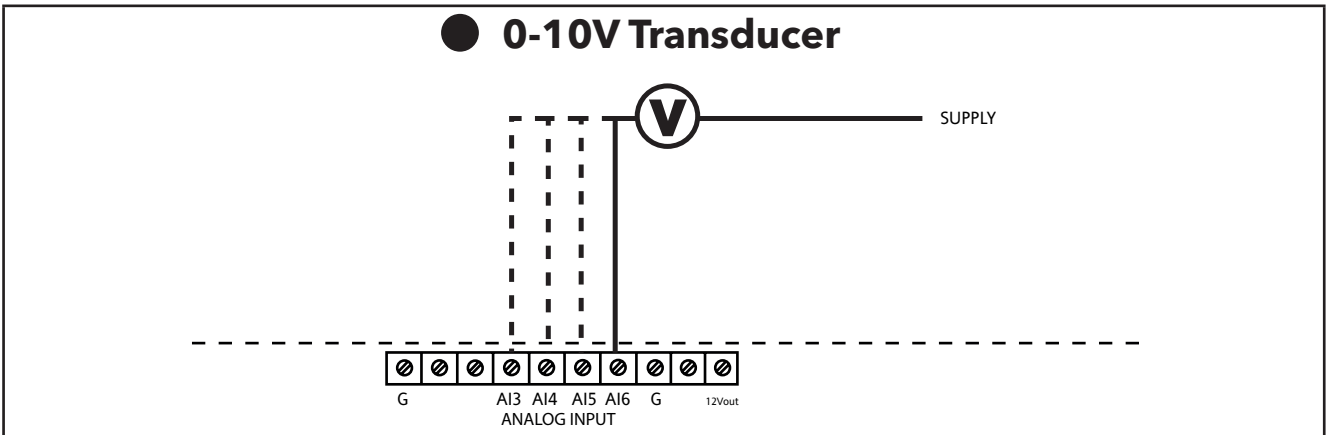

Fig. 18. 0-10 V transducer connection

Example: Digital Input Connection (through analog input terminal)

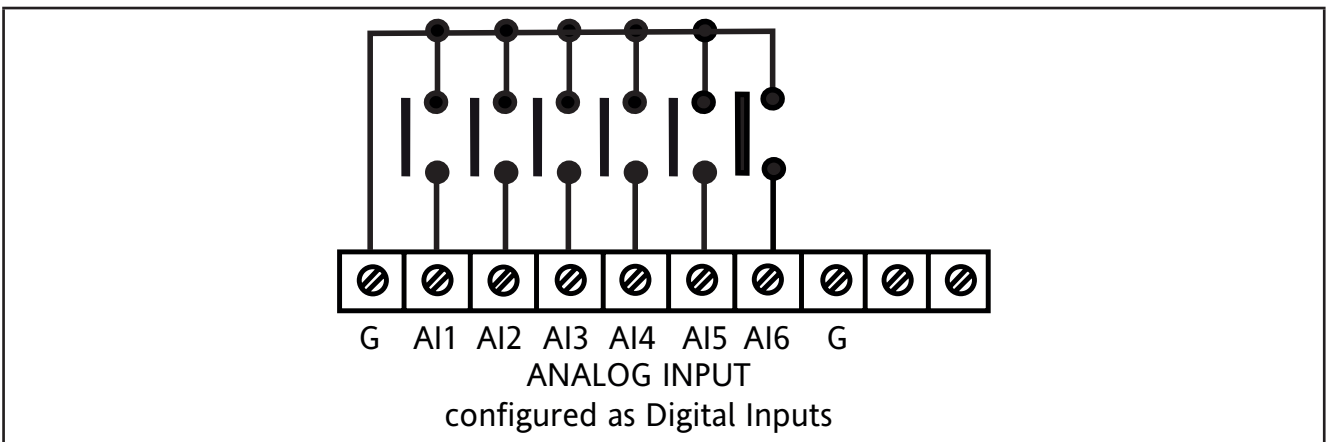

Fig. 19. Analog Inputs configured as Digital Inputs

Example: 4...20 mA pressure transducer connection

Analog Inputs AI3...AI6 are available as 4...20 mA pressure transducer connection.

In the case of a generic 3-wire transducer, connect the 0 V reference wire (ground if so indicated by the transducer manufacturer) to terminal GND and the transducer power supply to **12 Vdc** screw terminal.

NOTICE

INOPERABLE EQUIPMENT

Verify all wiring connections before applying power.

Failure to follow these instructions can result in equipment damage.

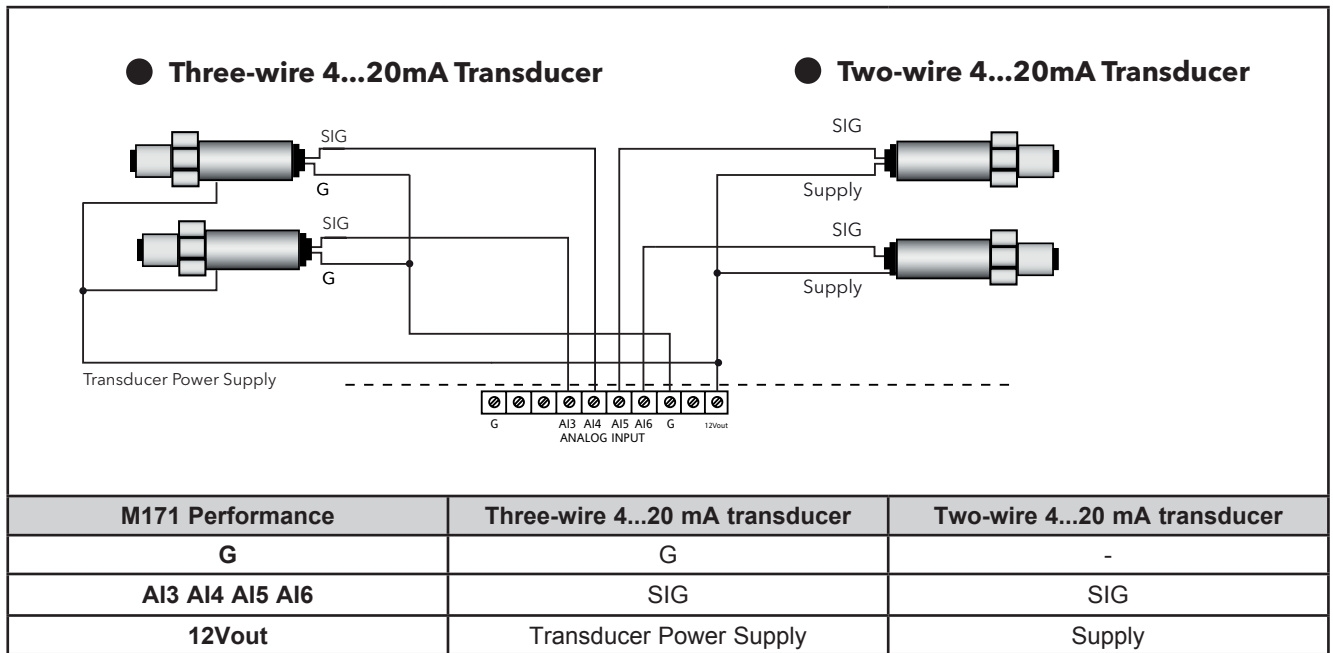

Fig. 20. 4...20 mA pressure transducer connection

Example: ratiometric transducer connection

Analog Inputs AI3...AI6 are available as ratiometric transducer connection

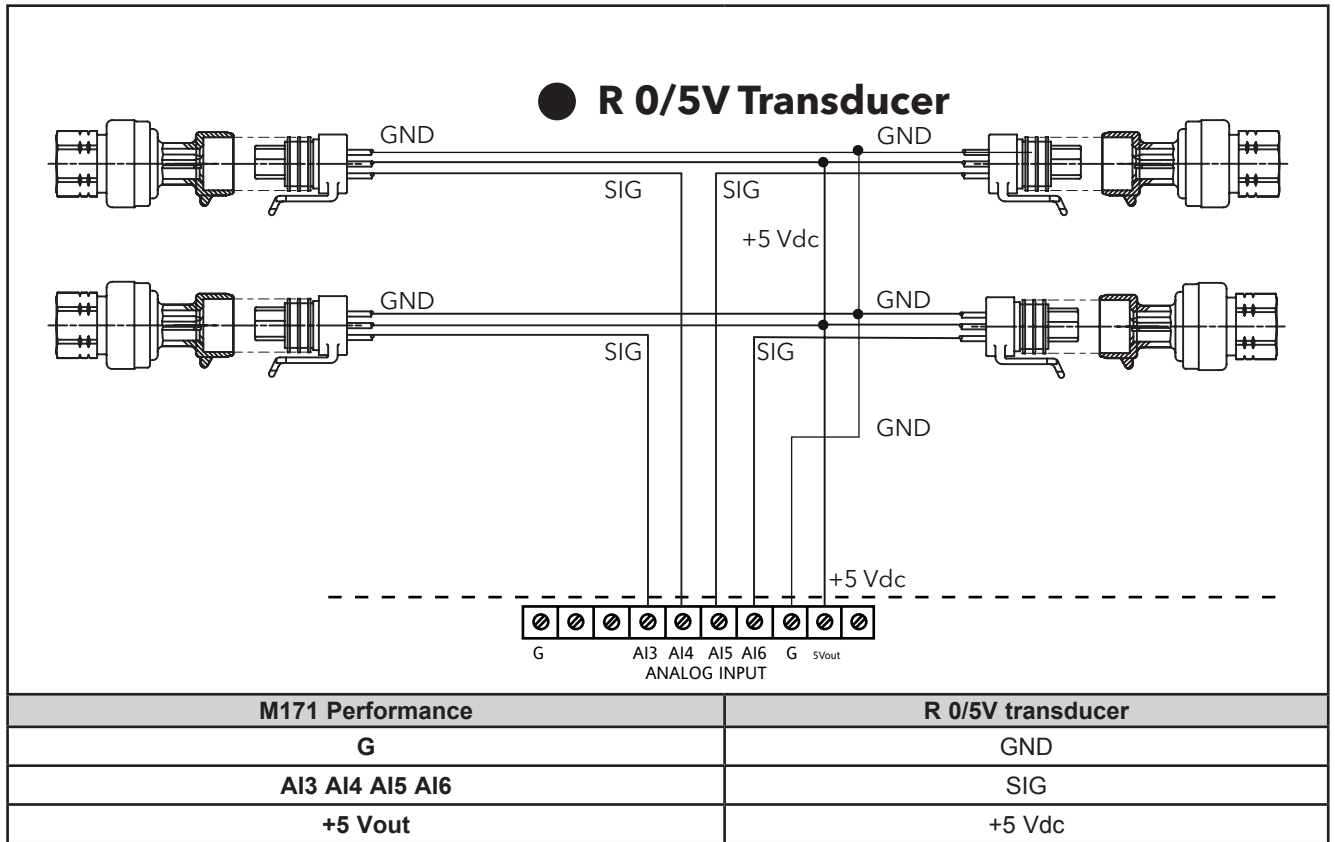

Fig. 21. Ratiometric transducer connection

Example: fan module connection

- 5 available analog outputs: AO1...AO5
- Example diagram with 4 ...20mA or 0-10V fan module

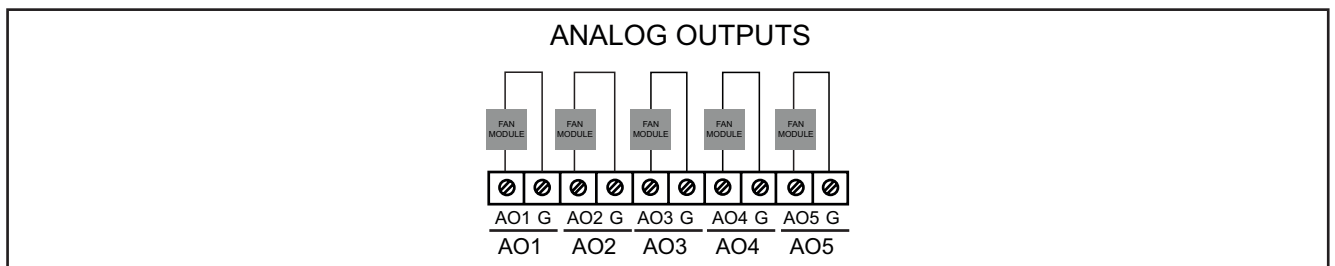

Fig. 22. Fan module connection

Example: Open Collector connection

- 2 Open Collector outputs available as Open Collector connection: AO4/AO5
- Example with an external relay

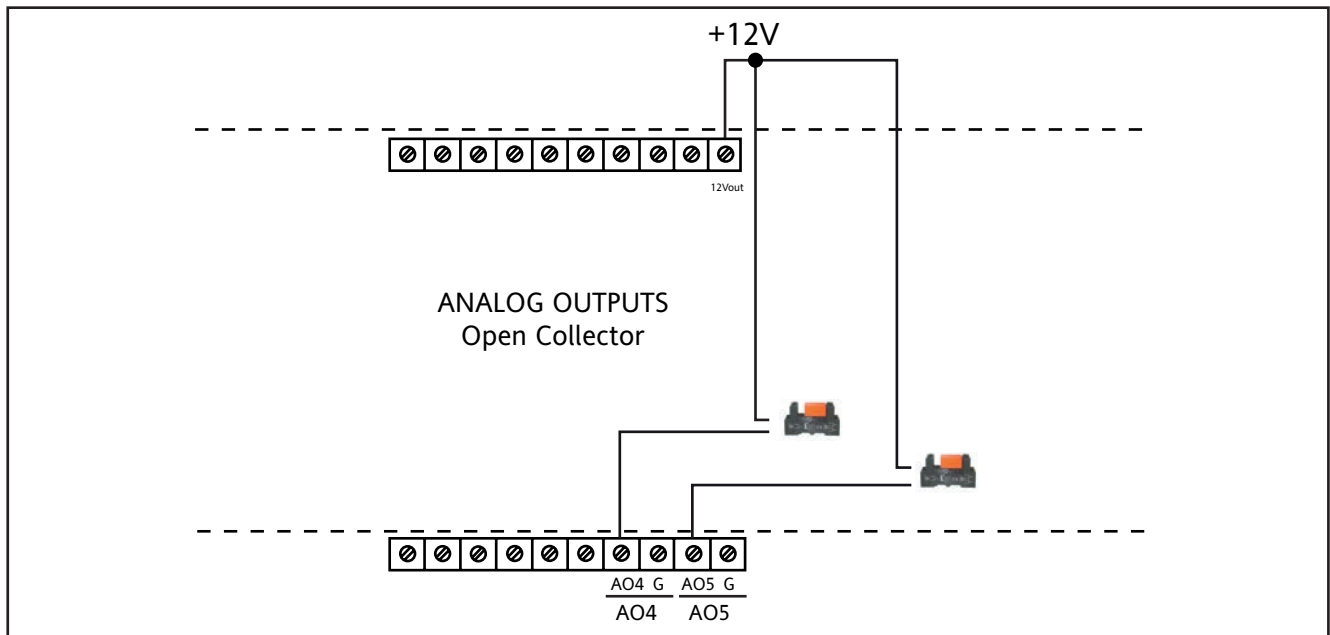

Fig. 23. Open Collector connection

3.2.4. M171 Performance / M171 Display Graphic connection

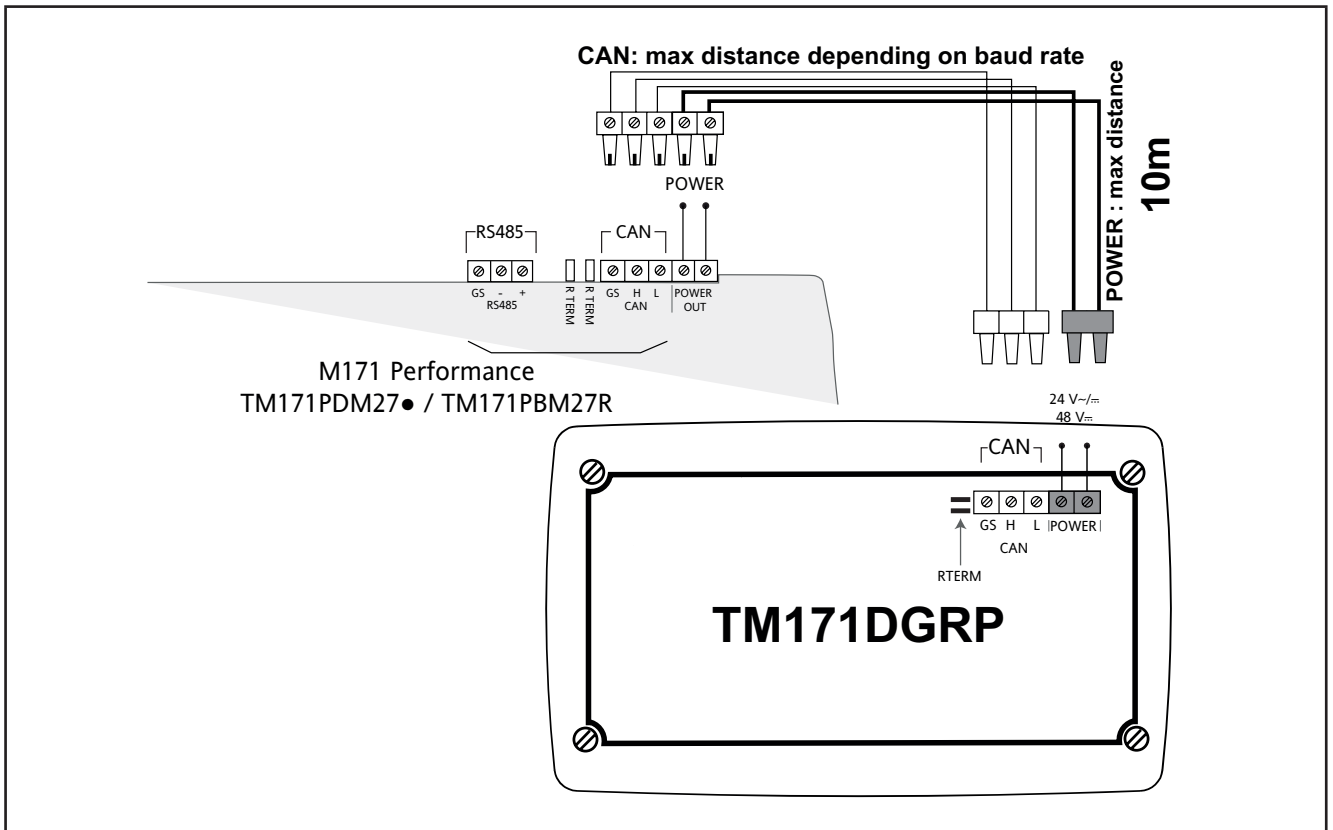

Fig. 24. M171 Performance / M171 Performance Display Graphic (TM171DGRP) terminal connection

NOTE: When supplying power from the **M171 Performance logic controllers**, make the power connection cable as short as possible.

NOTICE

INOPERABLE EQUIPMENT

Do not connect a power cable longer than 10m.

Failure to follow these instructions can result in equipment damage.

	LABEL	DESCRIPTION	NOTES
POWER	POWER IN	+24 Vac/dc or +48 Vdc power supply	Maximum cable length 10m
			from TM171P•M27• or separate power supply
CAN	GS H L	Isolated CAN serial GS ground serial insulated from G	R TERM termination resistors for CAN
			Maximum cable length See 3.1.6. Serial connections on page 27

3.2.5. M171 Performance Flush TM171PFE03 and TM171PFE03HR connection

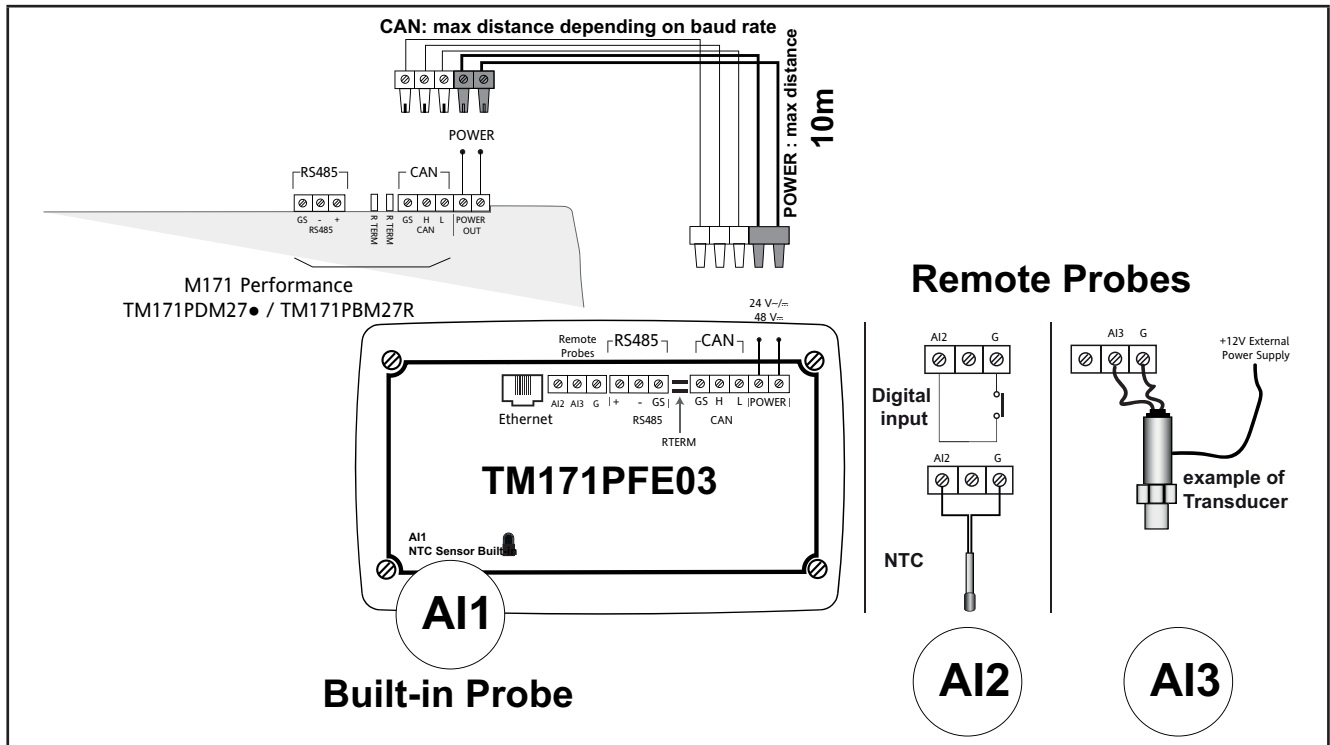

Fig. 25. TM171PFE03 connection

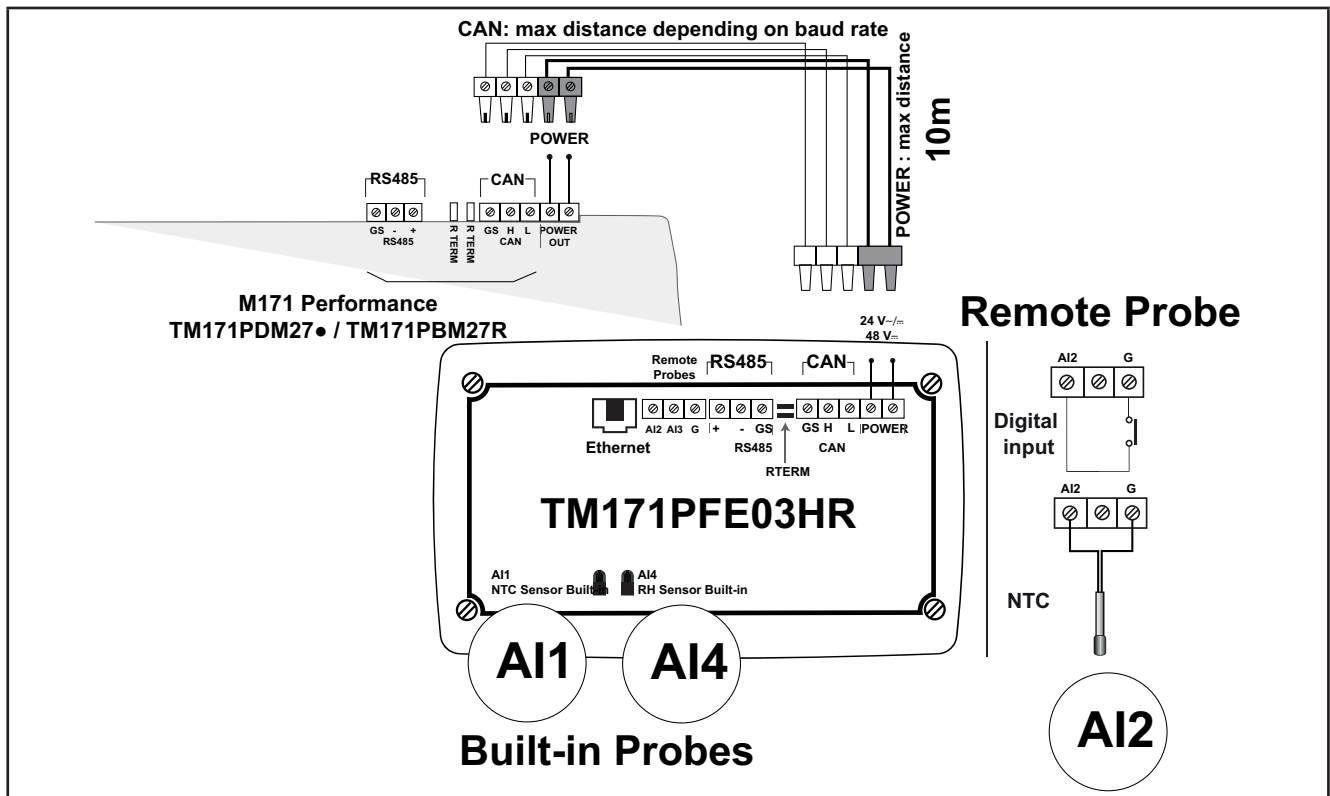

Fig. 26. TM171PFE03HR connection

NOTE: When supplying power from the **M171 Performance logic controllers**, make the power connection cable as short as possible.

NOTICE

INOPERABLE EQUIPMENT

Do not connect a power cable longer than 10m.

Failure to follow these instructions can result in equipment damage.

Label	Description	Notes
POWER	+24 Vac/dc or +48 Vdc power supply	Pin POWER Vout on TM171PDM27● / TM171PBM27R Max. distance 10m M171 Performance Flush / TM171PDM27● / TM171PBM27R
CAN GS H L	Isolated CAN serial GS ground serial isolated from G	R TERM termination resistors for CAN
RS485 GS - +	Isolated RS485 serial GS ground serial isolated from G	Apply 120 Ω terminal resistors
Ethernet	ETHERNET serial	-
Built-in AI1 NTC Sensor	On-board NTC sensor	-
AI2 Remote Probes G	NTC, D.I. remote Ground GND	Probe not included
AI3 Remote Probes G	4...20 mA / 0-10 V +/- 0-5 V Ground GND	TM171PFE03 Probe not included 12 V External power supply
Built-in AI4 RH Sensor	On-board RH% sensor	TM171PFE03HR

3.3. M171 Performance protocol connectivity

3.3.1. Example: CAN (Field) network connection

A CAN (Field) network connection can be constituted by:

- Max 1 **M171 Performance TM171PDM27●** functioning as MASTER
- Max 12 **M171 Performance TM171EP●●R** functioning as SLAVES

NOTE: No more than two **M171 Performance Display Graphic (TM171DGRP)** can be added to the network connected to **M171 Performance TM171PDM27●**

The **M171 Performance Display Graphic (TM171DGRP)** is supplied by **TM171PDM27●** via the POWER OUT output.

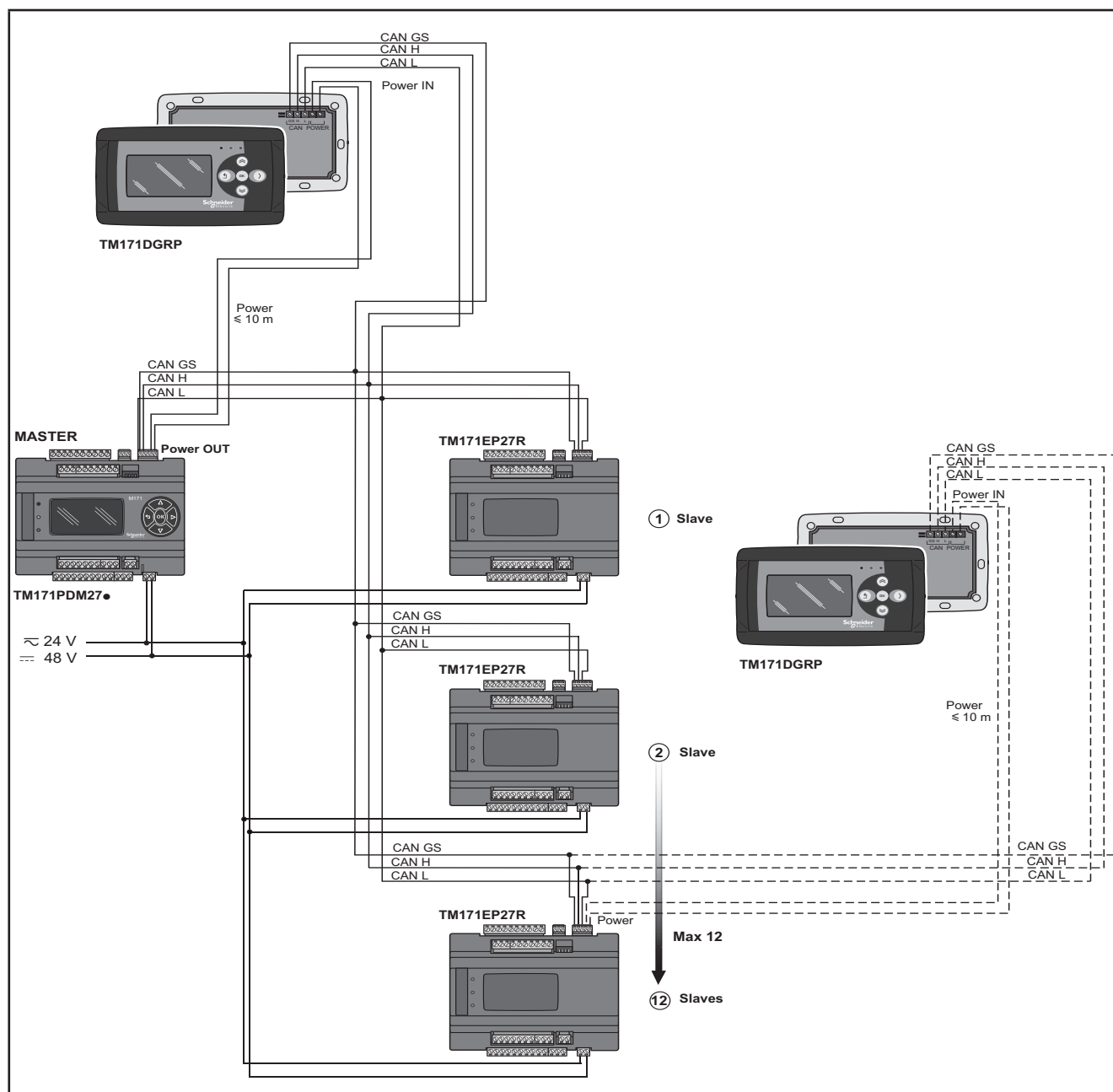

Fig. 27. CAN (Field) network connection using M171 Performance

3.3.2. Example: CAN connection (Network)

A CAN connection (Network) can be constituted by:

- 1 M171 Performance TM171PDM27●
- 1 M171 Performance Display Graphic (TM171DGRP) connected in CAN to M171 Performance TM171PDM27● or alternatively, to TM171PBM27R.

NOTE: Max 10 M171 Performance TM171PBM27R connected in CAN (binding).

The M171 Performance Display Graphic (TM171DGRP) is supplied by TM171PDM27● via the POWER OUT output.

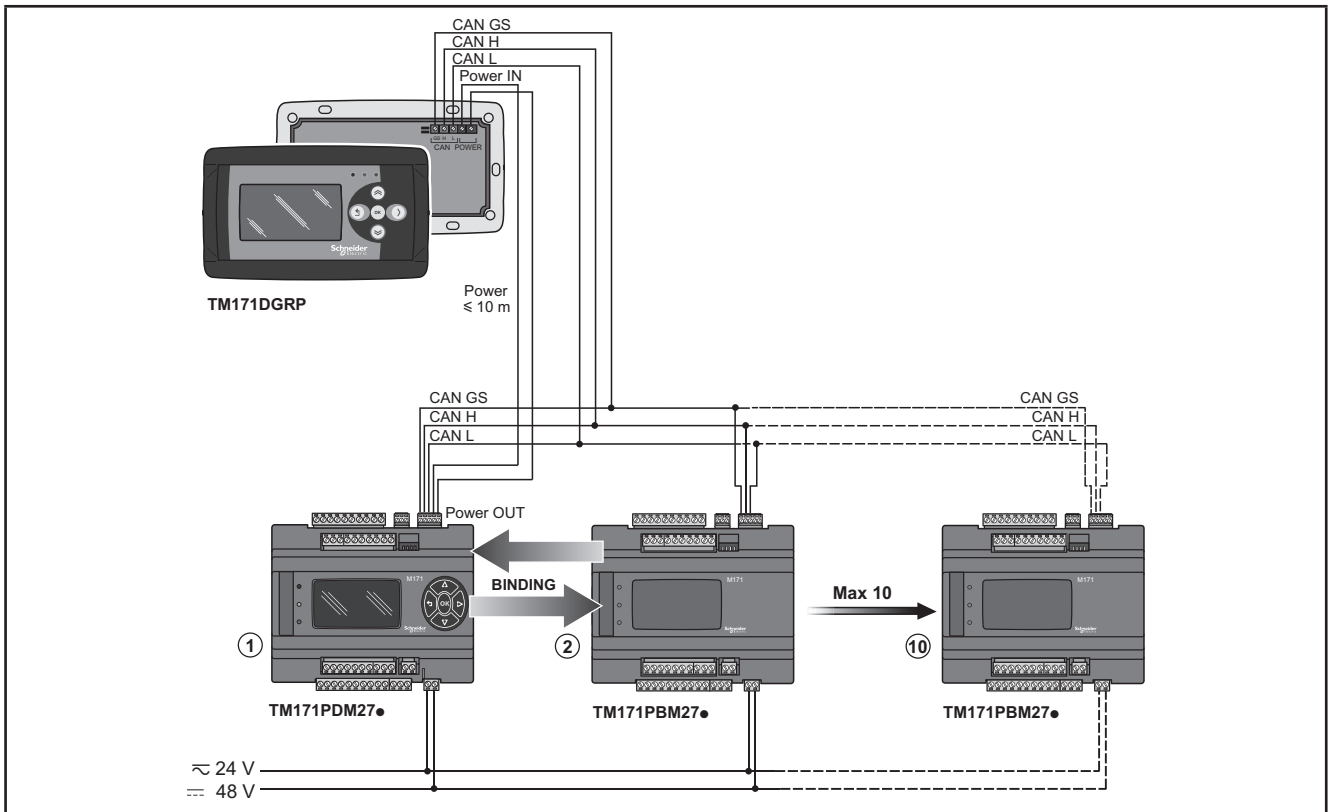

Fig. 28. CAN connection (Network) using M171 Performance

3.3.3. Example: RS485 connection (Field)

A RS485 connection (Field) can be constituted by:

Description	Notes
1 M171 Performance TM171PDM27●	TM171PDM27● is in Modbus RTU Master mode
Max 127 M171 Performance TM171EP27R expansion modules connected in RS485	TM171EP27R are in Modbus RTU Slave mode
1 M171 Performance Display Graphic (TM171DGRP) connected in CAN to M171 Performance TM171PDM27●	-

The M171 Performance Display Graphic (TM171DGRP) is supplied by TM171PDM27● via the POWER OUT output.

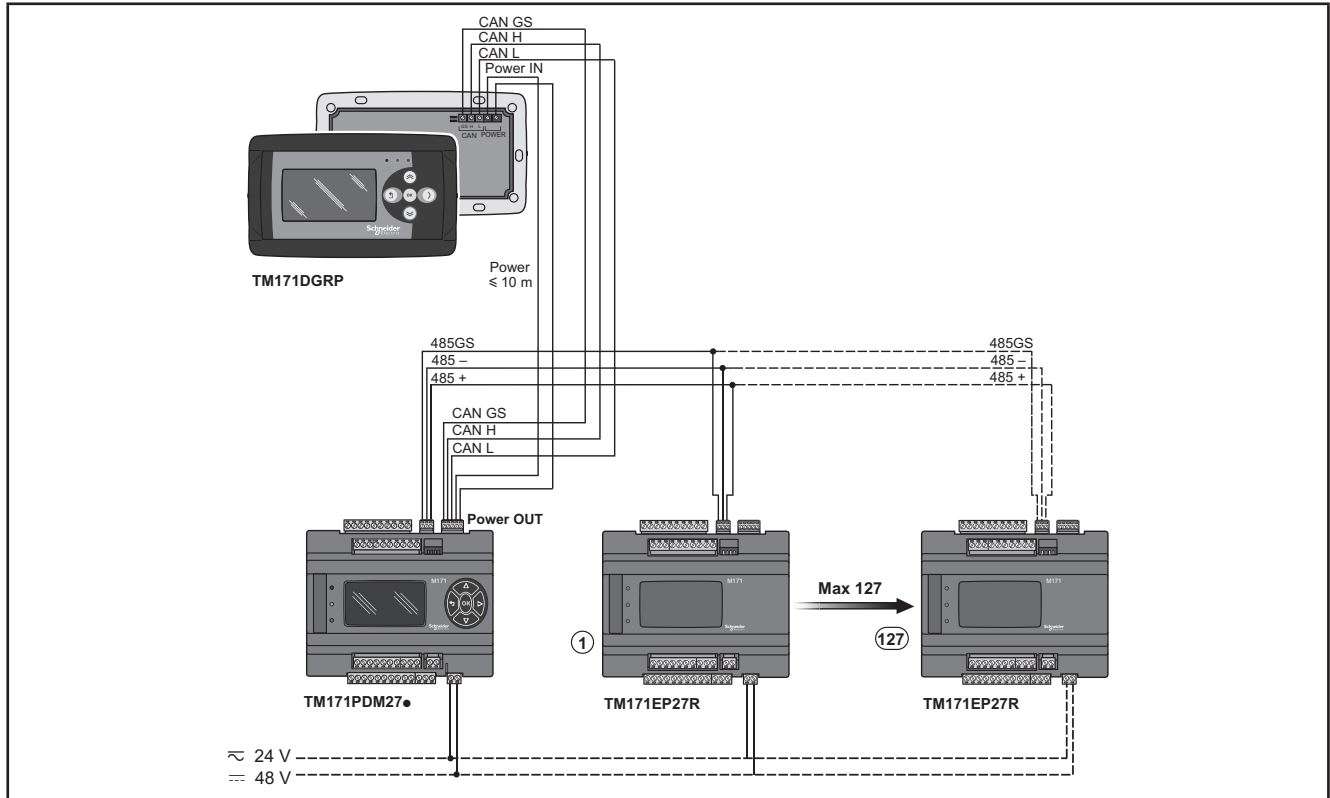

Fig. 29. RS485 connection (Field) using M171 Performance

3.3.4. Example: RS485 connection with the Modicon M171O network

A RS485 connection with the **Modicon M171O** network can be constituted by:

Description	Notes
M171 Performance TM171PDM27●	TM171PDM27● is in Modbus RTU Master mode
Max 127 M171 Performance TM171PDM27● / TM171PBM27R or Modicon M171O (TM171O●M●●R / TM171ODM22S) (Modbus Slave) or Schneider Electric and/or third-party devices equipped with RS485 serial	All devices equipped with RS485 are in Modbus RTU Slave mode (including the M171 Performance logic controllers) See also the Modicon M171O manual for further details.
CAN network – see 3.3.1. Example: CAN (Field) network connection on page 40.	The CAN connection can be <ul style="list-style-type: none"> • Field, as illustrated • Network, if one or more M171 Performance TM171PDM27● / TM171PBM27Rs are connected
1 M171 Performance Display Graphic (TM171DGRP) connected in CAN to M171 Performance TM171PDM27●	-

The **M171 Performance Display Graphic (TM171DGRP)** is supplied by **TM171PDM27●** via the POWER OUT output.

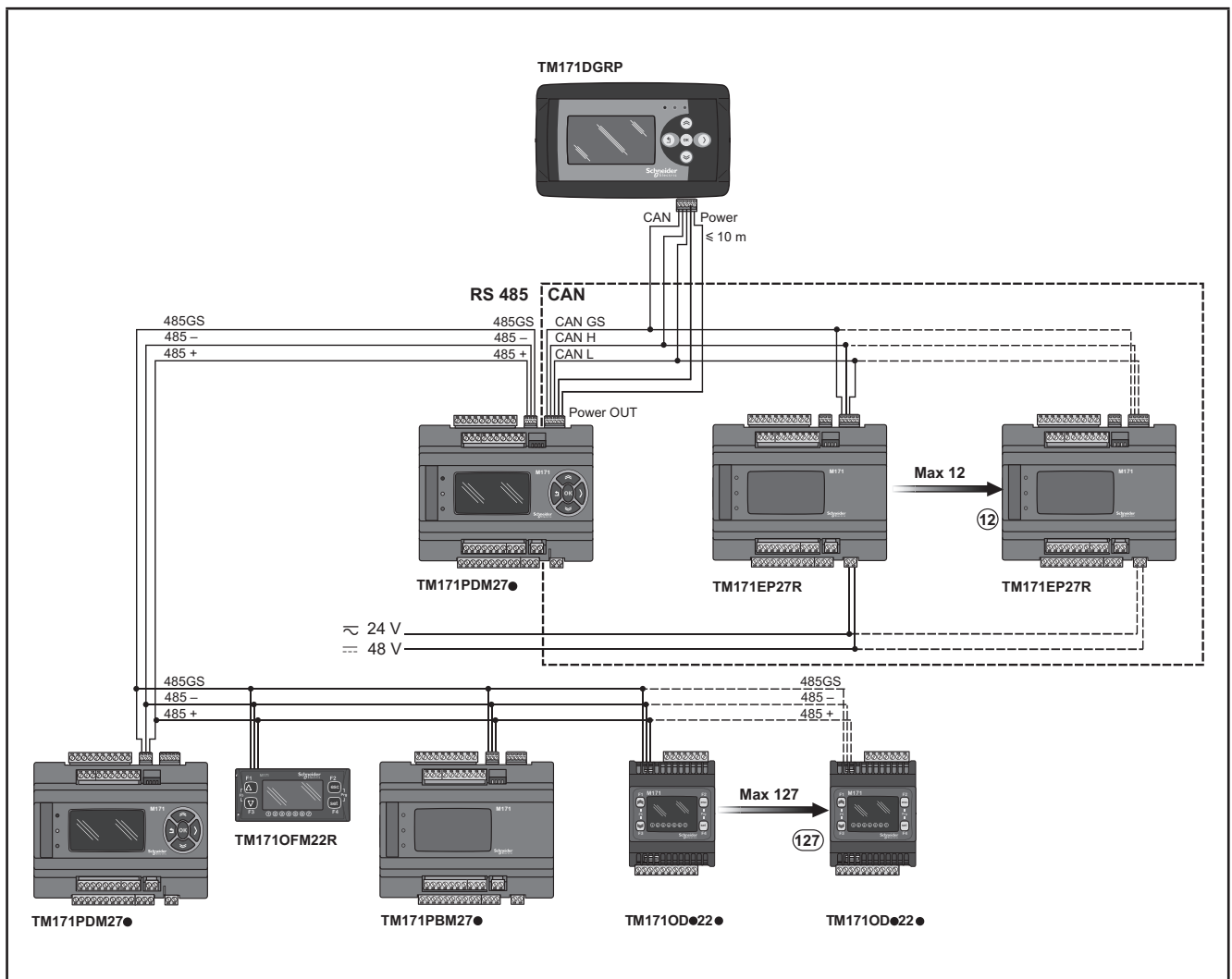

Fig. 30. RS485 connection with the Modicon M171O network using M171 Performance

3.4. M171 Performance Flush protocol connectivity

3.4.1. Example: RS485 connection (Field)

A RS485 connection (Field) can be constituted by:

Description	Notes
1 M171 Performance Flush	M171 Performance Flush is in Modbus RTU Master mode
Max 127 M171 Performance TM171EP27R expansion modules connected in RS485	TM171EP27R are in Modbus RTU Slave mode

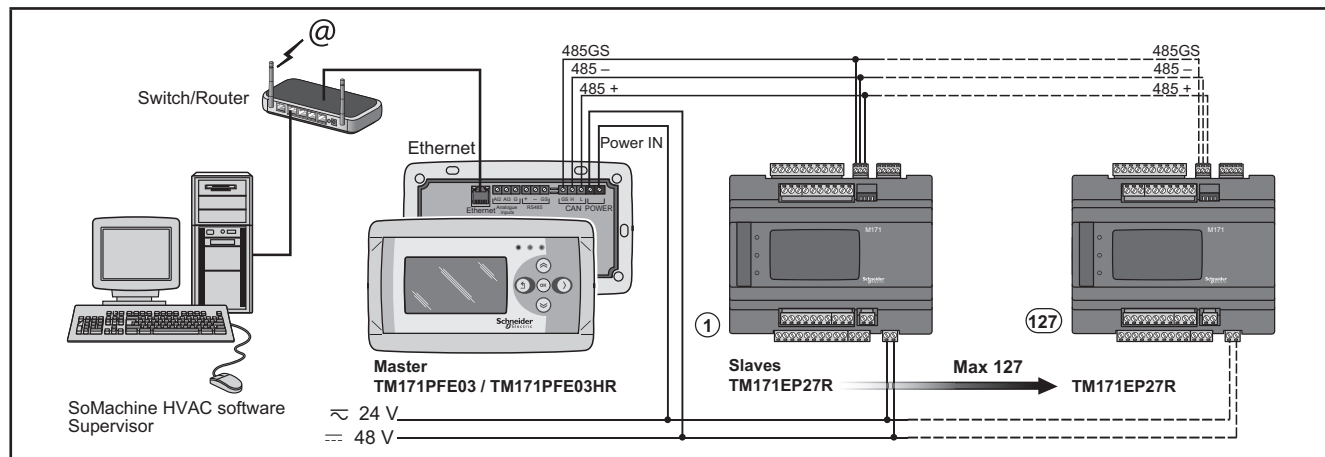

Fig. 31. RS485 connection (Field) using M171 Performance Flush

3.4.2. Example: CAN connection

A CAN connection can be constituted by 1 M171 Performance Flush.

NOTE: Max 12 M171 Performance TM171EP●●R expansion modules connected in CAN.

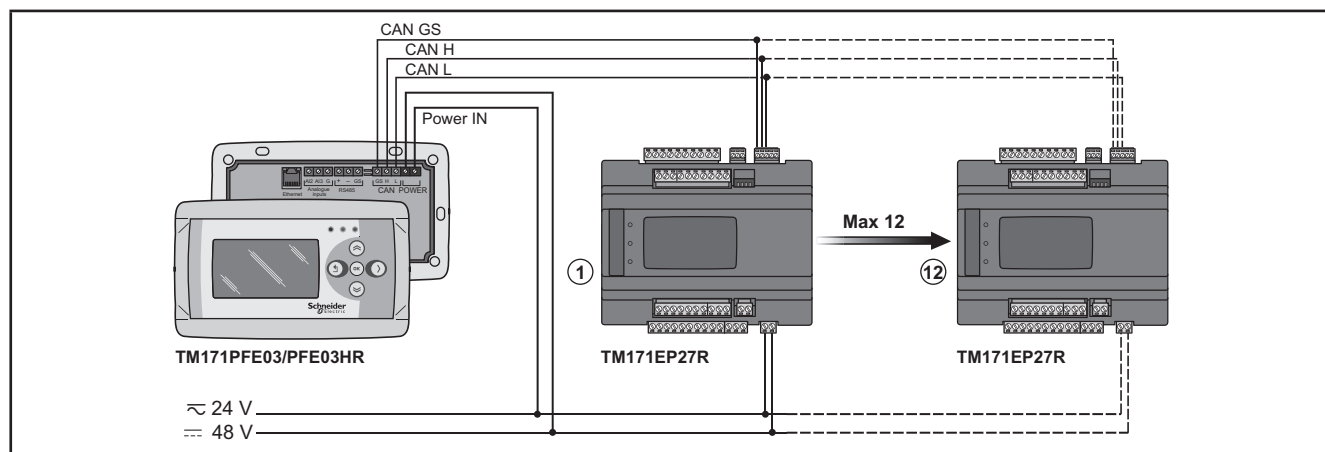

Fig. 32. CAN connection using M171 Performance Flush

3.4.3. Example: RS485 connection with the Modicon M171O network

A RS485 connection with the **Modicon M171O** network can be constituted by:

Description	Notes
1 M171 Performance Flush	M171 Performance Flush is in Modbus RTU Master mode
Max 127 M171 Performance TM171PDM27● /TM171PBM27R or Modicon M171O or Schneider Electric and/or third-party equipment equipped with RS485 serial	All devices equipped with RS485 are in Modbus RTU Slave mode (including the M171 Performance logic controllers) See also the Modicon M171O manual for further details.
CAN network	see 3.4.2. Example: CAN connection on page 44

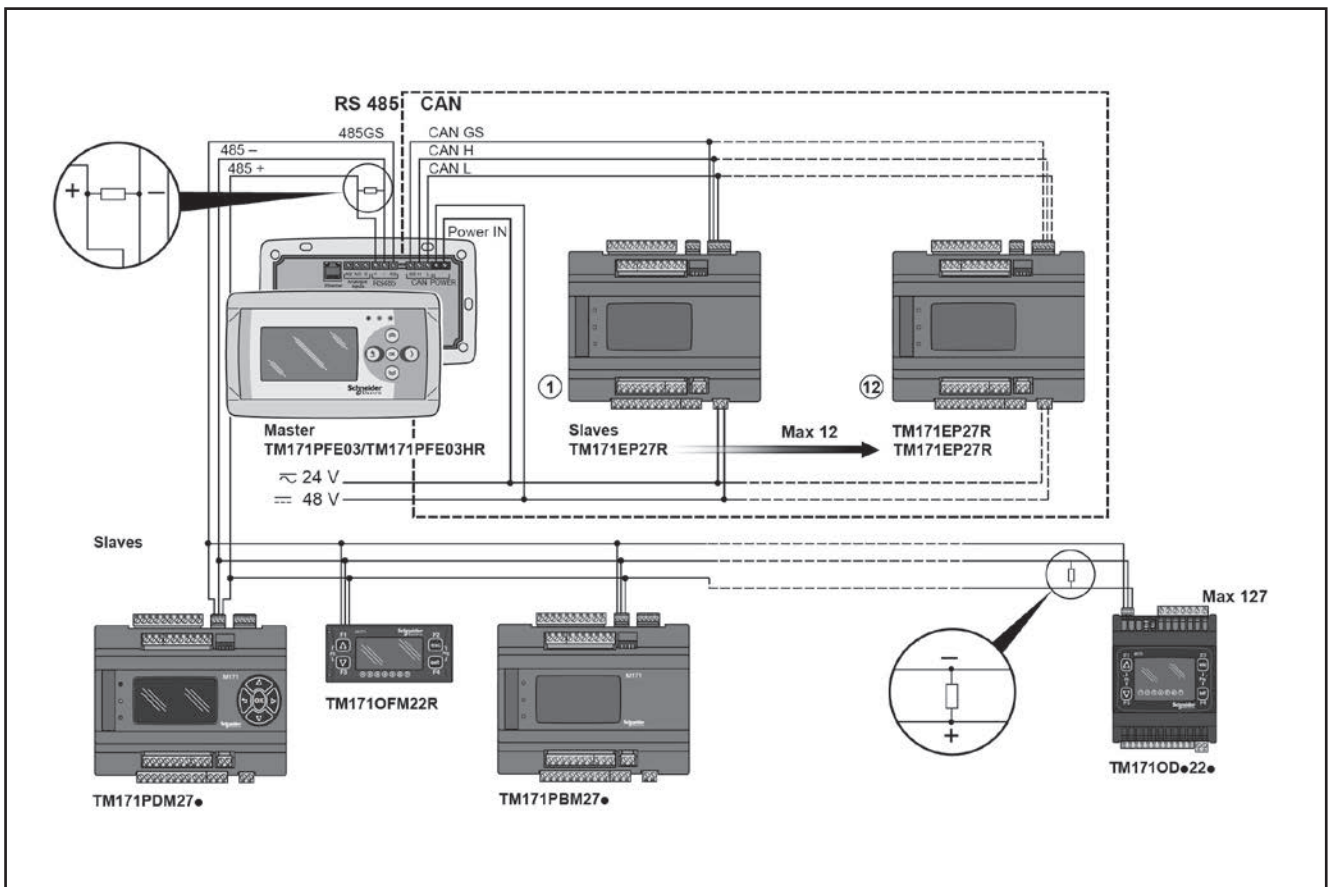

Fig. 33. RS485 connection with the Modicon M171O network using M171 Performance Flush

3.4.4. Example: CAN network connection

A CAN network connection can be constituted by 1 **M171 Performance Flush**.

NOTE: Max 10 **M171 Performance TM171PDM27● / TM171PBM27R**.

NOTE: CAN network: see **3.4.2. Example: CAN connection on page 44**

HMI menu

M171 Performance Flush can be equipped with its own menu (named Network menu).

In this case **M171 Performance Flush logic controller** is programmed with the network menu, which can read variables present in the **M171 Performance logic controller** network.

M171 Performance Flush logic controller can operate from the individual controllers and download up to 10 remote menus from the respective **M171 Performance logic controllers**.

In this case the remote menu allows 'local' navigation of the individual **M171 Performance logic controller**.

Controller application

The variables of the various controllers are shared (bound together).

An application present on **M171 Performance Flush** logic controller can use variables present in the network and share its own variables with other applications present on the respective **M171 Performance logic controllers**.

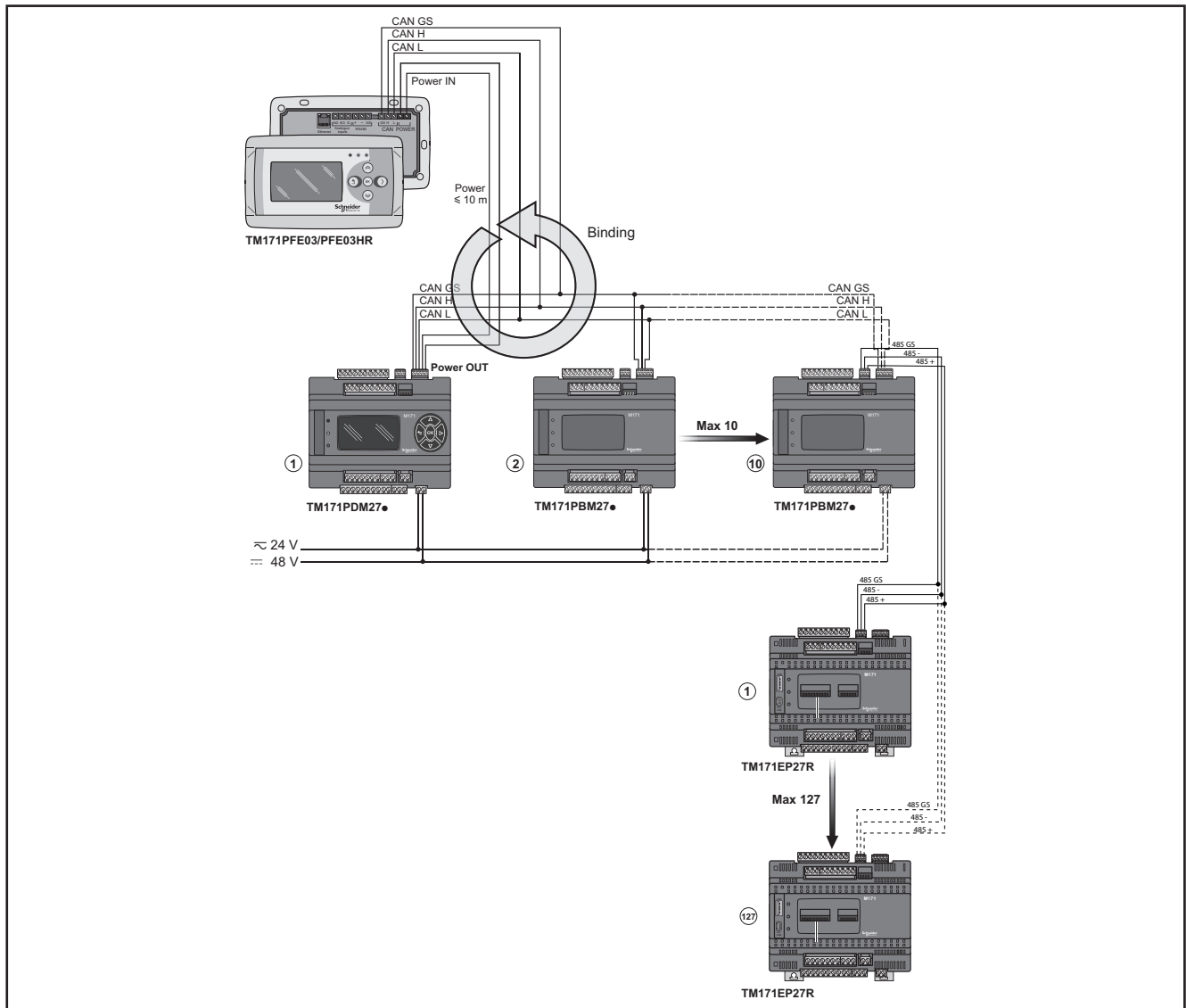

Fig. 34. CAN network connection using M171 Performance Flush

3.5. TM171A●●●● Communication Modules

Communication Modules are 2DIN modules that can be connected to an **M171 Performance** controller or an M172 Performance controller (with restrictions, refer to the M172 Performance controller Hardware Guide) via the Communication Module connector on the left side, behind the removable door. The Communication Module is anchored to the controller with the two fixing hooks.

It mounts to the DIN rail in the same way as the controller.

3.5.1. Communication Modules compatible with M171 and M172

Interface for	Communication Module	
RS 232	TM171ARS232	5A SPDT relay available
RS 485	TM171AMB TM171ARS485	RS 485 in Daisy Chain(1)
CAN Expansion Bus	TM171ACAN	CAN Expansion Bus in Daisy Chain(1)
LON	TM171ALON	LonWorks Communication Module

(1) Use a shielded cable. See **3.1.6. Serial connections on page 27**.

NOTE: The LonWorks communication module supports up to 63 nodes. Exceeding this specification may result in an electrical overload condition in the M171ALON Communication Module and consequently in the controller.

WARNING

UNINTENDED EQUIPMENT OPERATION

Do not exceed the maximum of 63 nodes on the TM171ALON Communication Module.

Failure to follow these instructions can result in death, serious injury, or equipment damage.

For more information on the LonWorks network, visit www.echelon.com/technology/lonwork/

3.5.2. Communication Modules exclusively compatible with M171

Interface for	Communication Module	
ETHERNET	TM171AETH TM171AETHRS485	The MACADDRESS is supplied in the box, Expressed as barcode and 12-digit alphanumeric code. The Ethernet connector shield is connected internally to the equipment ground, and therefore to the reference of the input and output channels
		WebVisu: WEB functionalities of M171 Performance TM171PDM27● or TM171PBM27R + TM171AETH/ TM171AETHRS485 Communication Module
PROFIBUS	TM171APBUS Profibus DP Slave-V0	Contact your local Schneider Electric representative for more information concerning the .GSD Profibus configuration file
		See official Profibus documentation for more detailed information

Communication Module **TM171A●●●●** are shown below:

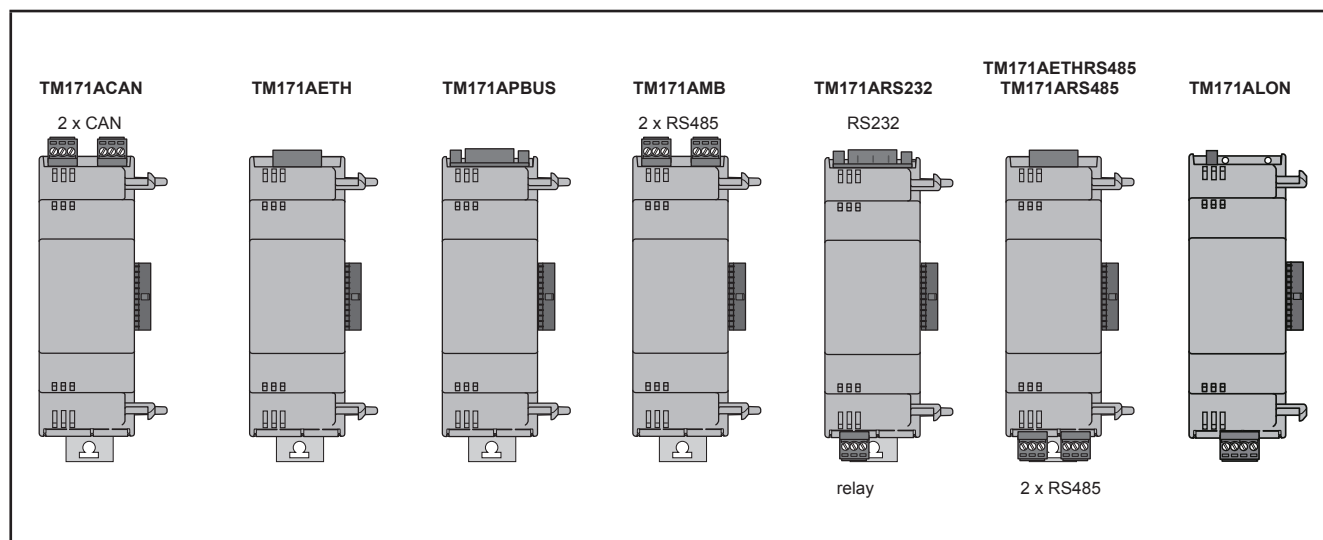

Fig. 35. TM171A●●●● Communication Modules

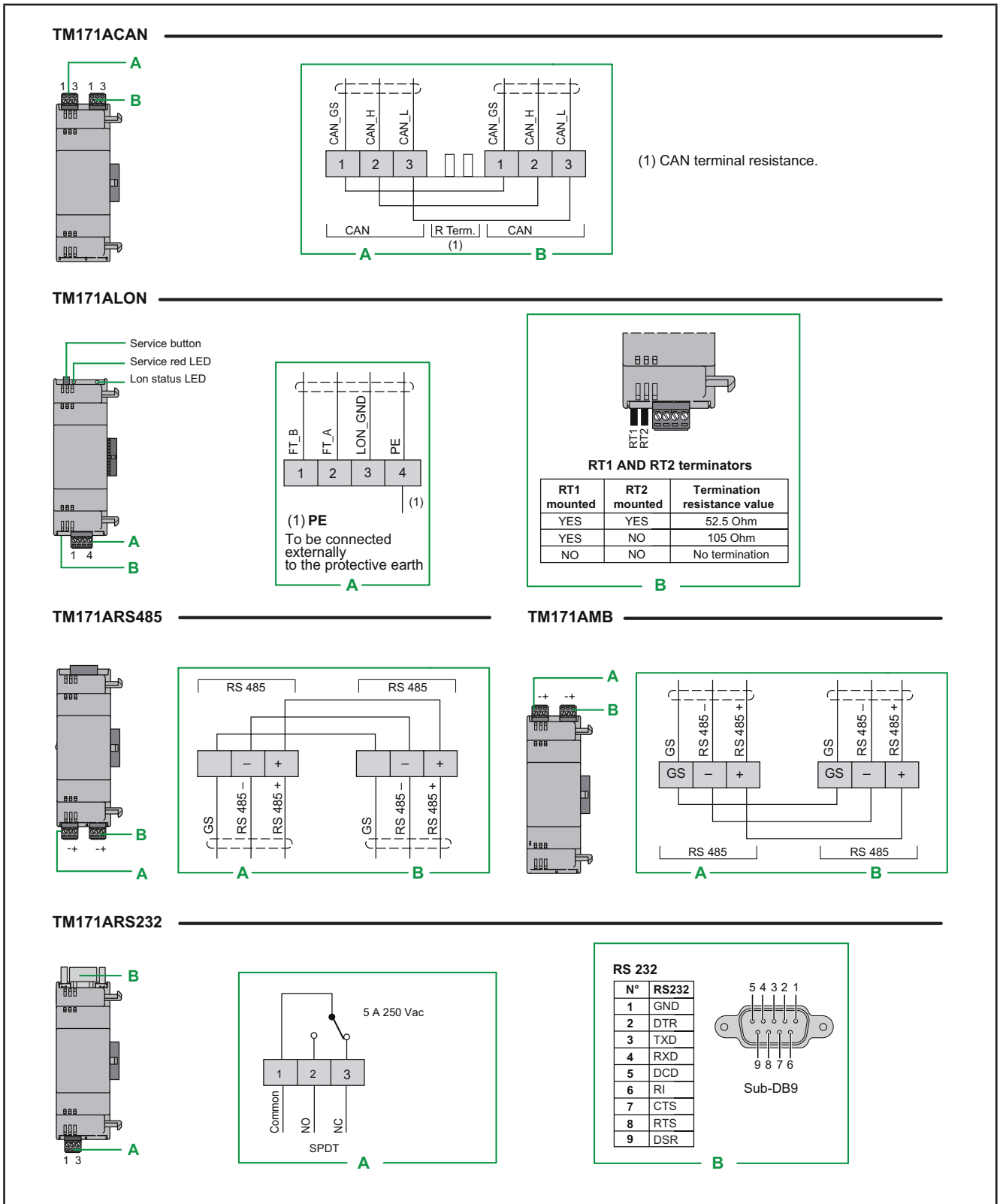

Fig. 36. Communication Modules compatible with M171/M172

TM171AETHRS485 / TM171ARS485



Fig. 37. ETHERNET, ETHERNET+RS485 Communication Modules

TM171APBUS

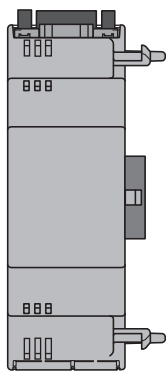

Profibus

N°	Profibus
1	Shield
2	Output ground 24 V
3	RXD-TXD +
4	Repeater Control Signal TRS
5	Ground 0 V
6	5 V
7	24 V
8	RXD-TXD-
9	Control Signal direction

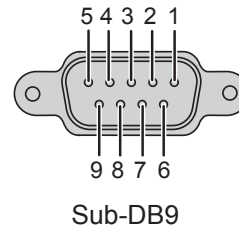

Pin	Required signals - pins 3-5-6-8
1	Shield To be connected externally to the protective earth
2	24V output ground
3	RXD-TXD +
4	RTS repeater control signal direction
5	Digital ground
6	5V
7	24V
8	RXD-TXD -
9	Direction control signal ground

Fig. 38. PROFIBUS Communication Module

NOTE: In a network with Profibus Communication Modules, the first and last element in the network must terminate with Profibus resistors.

3.5.3. TM171ARS232

The RS232 Communication Module allows **M171/M172** DIN rail mounted Performance controllers to communicate via an RS232 serial.

Modbus RTU communication protocol

The connection allows:

- connection to a supervision system using the Modbus RTU protocol
- connection of an IEC 61131-3 **TM171SW (SoMachineHVAC)** development system

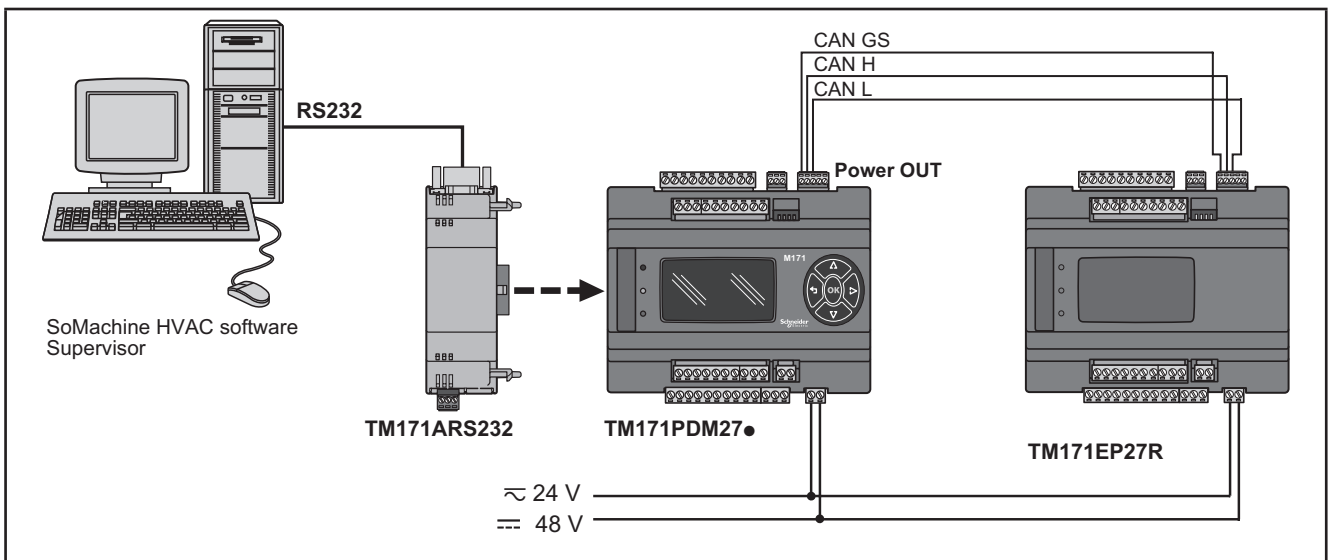

Fig. 39. Modbus RTU communication protocol using TM171ARS232

Modbus ASCII communication protocol send/receive AT commands for modem⁽¹⁾

This protocol activates when there is a modem connected to the Communication Module.
The connection allows:

- connection to a monitoring system using the Modbus ASCII protocol;
- connection of an IEC 61131-3 **TM171SW (SoMachineHVAC)** development system;
- send/receive TXT messages via a modem connected to the RS232⁽²⁾ port.

NOTE: The Communication Module has a relay that can be piloted from the controller application to allow the modem to be activated/reset or as an additional digital output.

⁽¹⁾ Refer to the **Modem_IEC.pll** software library in
C:\<Programs>\Schneider Electric\SoMachineHVAC\Catalog\FreeEvolution\PLC

⁽²⁾ Refer to the **SMS_IEC.pll** software library in
C:\<Programs>\Schneider Electric\SoMachineHVAC\Catalog\FreeEvolution\PLC

See **TM171SW (SoMachineHVAC)** Manual for details.

NOTE:

Refer to the section on Parameters / RS232 PASSIVE PLUG-IN folder (see **CHAPTER 9 Parameters on page 107**).

Refer to the section on Parameters / MODEM folder (see **CHAPTER 9 Parameters on page 107**).

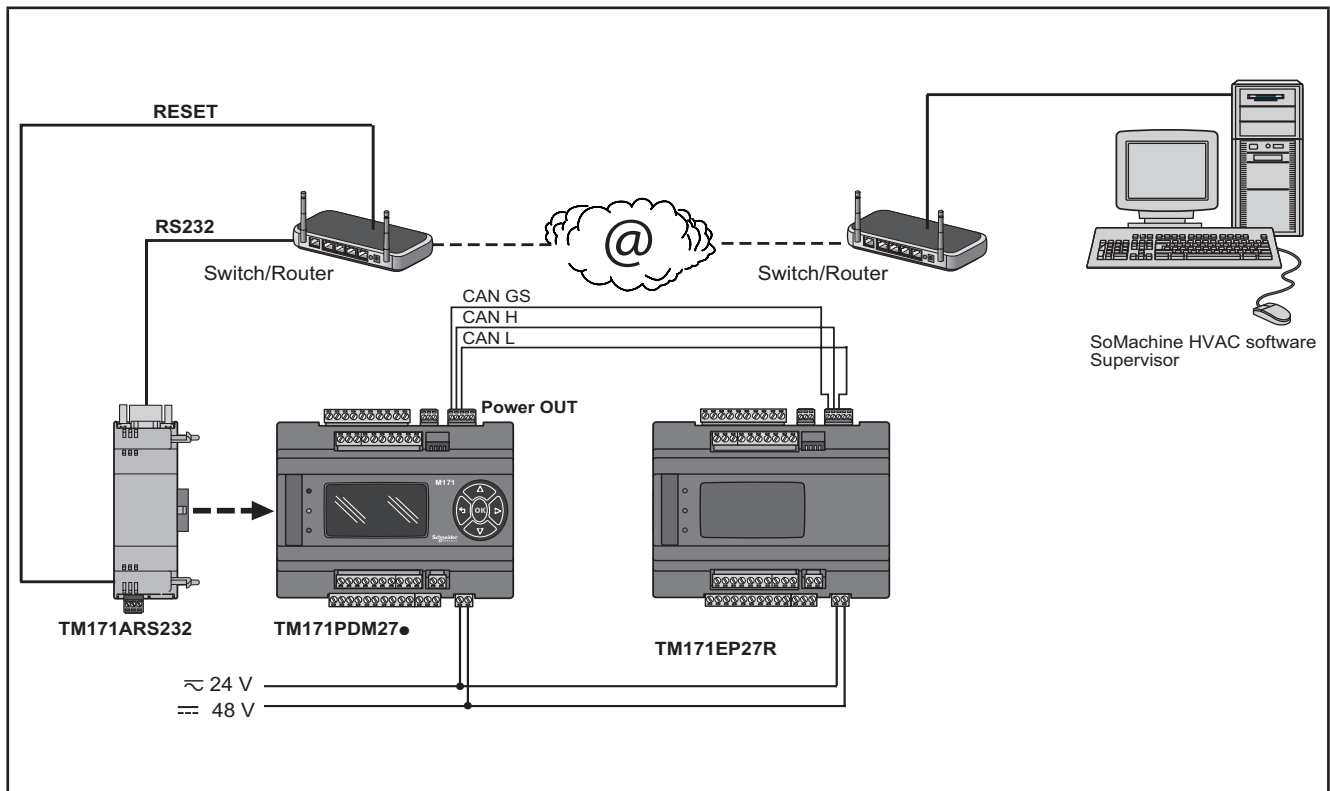

Fig. 40. Modbus ASCII communication protocol using TM171ARS232

3.5.4. TM171AETH / TM171AETHRS485

The Ethernet Communication Module enables communication of the **M171 Performance TM171PDM27● / TM171PBM27R** on an Ethernet network using the Modbus TCP protocol.

The connection allows:

- network connection of different controllers and/or applications exchanging variables and/or parameters (**network**)
- connection to a supervision system using the Modbus TCP protocol
- connection of an IEC 61131-3 **TM171SW (SoMachineHVAC)** development system

NOTE:

The MAC ADDRESS (barcode and 12-digit alphanumeric code) is supplied in the box containing the Ethernet Communication Module.

Refer to the section on Parameters / ETHERNET PASSIVE PLUG-IN folder (see **CHAPTER 9 Parameters on page 107**).

NOTE: The Ethernet connector shield is connected internally to the functional ground, and therefore to the reference of the input and output channels. Care must be taken to the fact there may be within the Ethernet communications system other grounding points. Interconnection of multiple protective earth grounding points in the same installation can cause current loops and voltage shifts across conductive parts of the equipment.

⚠ WARNING

UNINTENDED EQUIPMENT OPERATION

Do not connect the connector shield to protective earth (PE) or to functional earth (FE) of your installation.

Failure to follow these instructions can result in death, serious injury, or equipment damage.

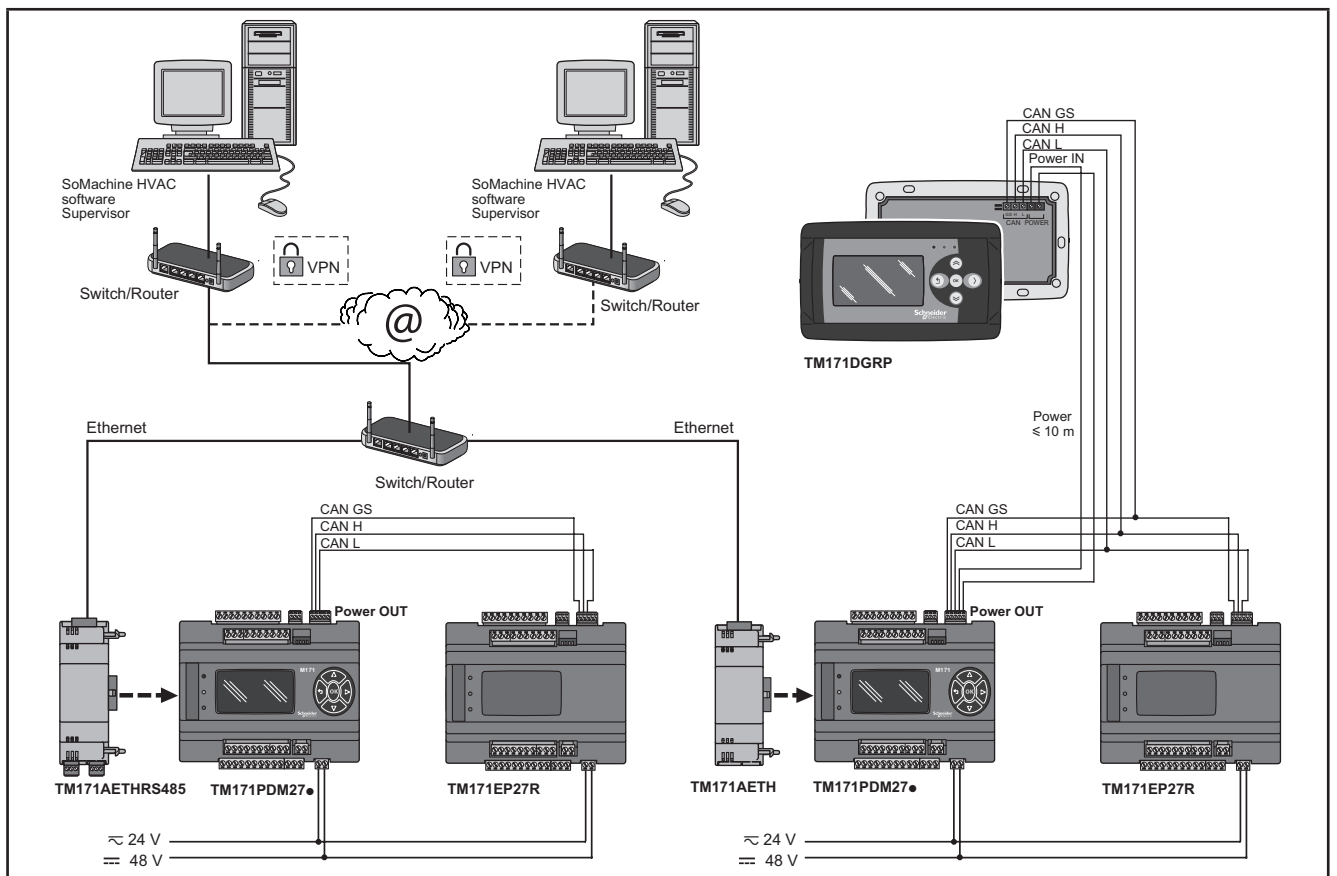

Fig. 41. Modbus TCP protocol using TM171AETH

VPN is not necessary when using DynDNS connection.

Protocol	Field	Network
Modbus TCP	-	Max 10 M171 Performance + 2 M171 Performance Display Graphic (TM171DGRP) Max Modbus Messages = 128 / number of M171 Performance connected

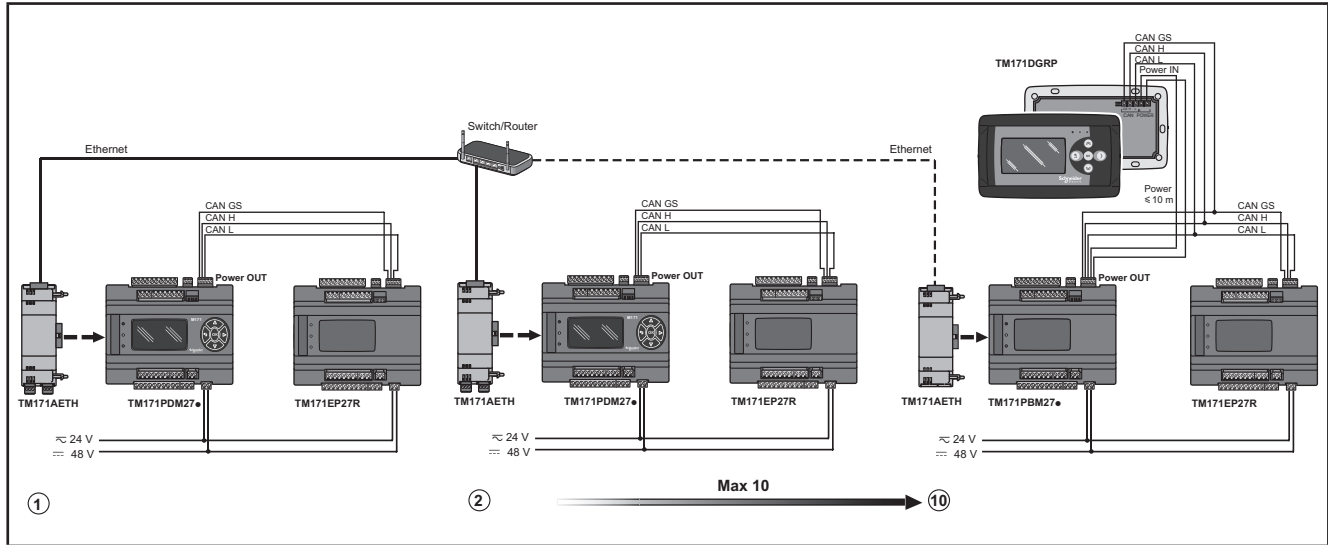

Fig. 42. Modbus TCP protocol using TM171AETH - limits

3.5.5. Example: BACnet / IP

Protocol	Field	Network
BACnet IP	-	Max 4 M171 Performance

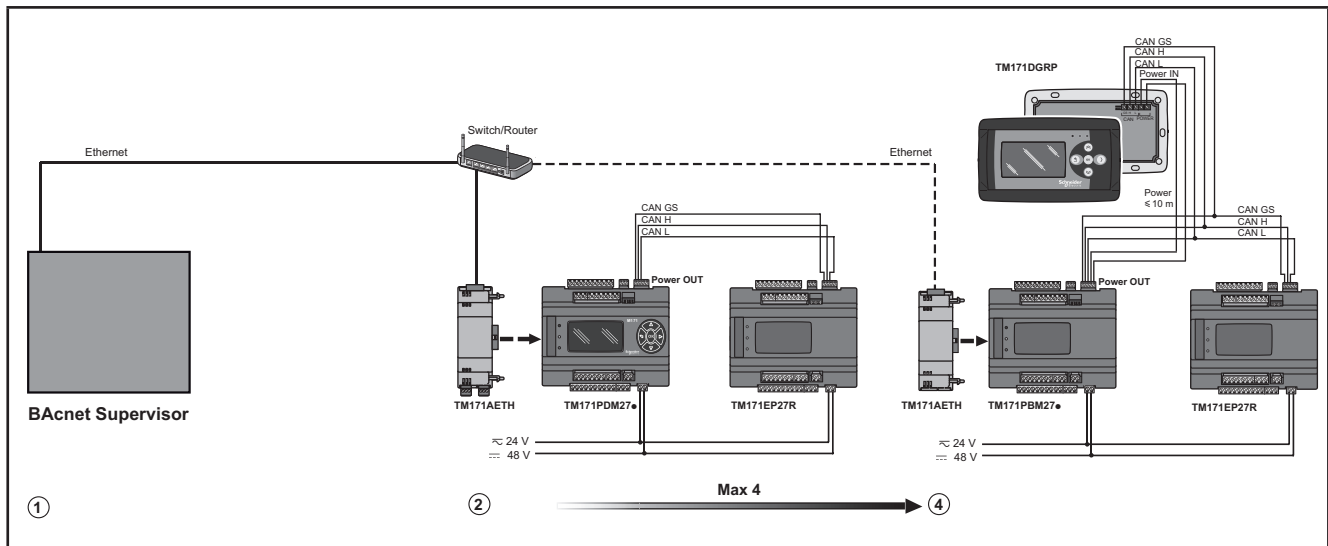

Fig. 43. BACnet IP protocol using Ethernet port of the M171 Performance

WebVisu (WEB SERVER HTTP)

WebVisu is an **M171 Performance TM171PDM27●**, **TM171PBM27R** with the **TM171AETH Communication Module**. The Ethernet Communication Module also uses HTTP protocol, i.e. allowing access to a Web Server contained in **M171 Performance**.

TM171SW (SoMachineHVAC v2.0 or greater) allows the creation and management of web pages internally of **WebVisu (WEB SERVER HTTP)**, i.e. a website in miniature.

WEB functionalities allow local and remote access by way of an ordinary browser. Thanks to the web connection, the system provides reading, support and diagnostics services, as well as e-mail alarm alerts.

Main web functionalities:

- Web-based access.
- Remote reading and support.
- Local and remote system control, including alarms management.
- Preventive and predictive maintenance.
- Email alarm alerts.

Care must be taken and provisions made for use of this product as a control device to avoid inadvertent consequences of commanded machine operation, controller state changes, or alteration of data memory or machine operating parameters.

⚠ WARNING

UNINTENDED EQUIPMENT OPERATION

- Configure and install the mechanism that enables the remote HMI local to the machine, so that local control over the machine can be maintained regardless of the remote commands sent to the application.
- You must have a complete understanding of the application and the machine before attempting to control the application remotely.
- Take the precautions necessary to assure that you are operating remotely on the intended machine by having clear, identifying documentation within the application and its remote connection.

Failure to follow these instructions can result in death, serious injury, or equipment damage.

Refer to the section on Parameters / ETHERNET PASSIVE PLUG-IN folder (see [CHAPTER 9 Parameters on page 107](#)).

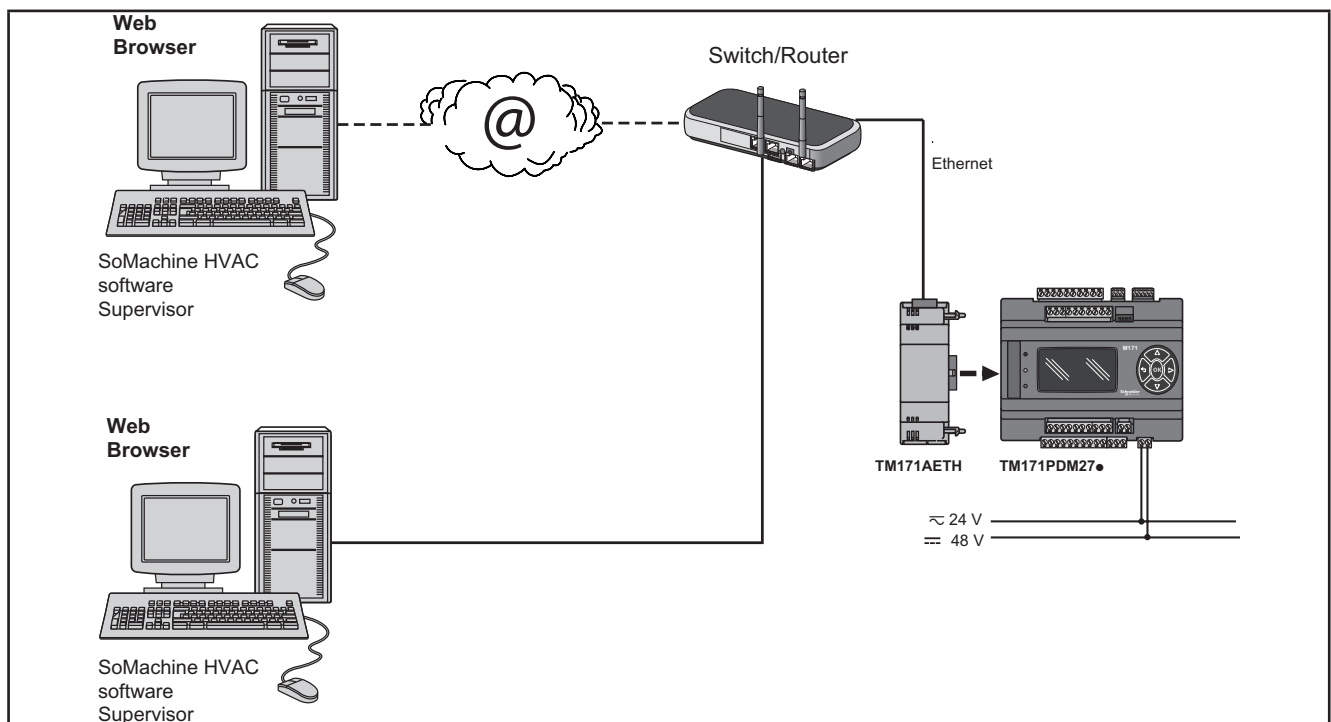

Fig. 44. WebVisu (WEB SERVER HTTP) using M171 Performance and TM171AETH

BRIDGE

TM171SW (SoMachineHVAC) allows monitoring of the **Modicon M171O** or M171P controller or third party devices, typically Modbus/RTU slaves, where **WebVisu** (or **M171 Performance** with **TM171AETH** Communication Module) is the Master Modbus/RTU.

In a **TM171SW (SoMachineHVAC)** project, more exactly, **WebVisu** is used as a Modbus/TCP to Modbus/RTU protocol conversion element for Modbus 0x03 and 0x10 commands.

For example from **TM171SW (SoMachineHVAC)**, set the connection with the **Modicon M171O** as Modbus/TCP, inserting the **WebVisu** IP address and the Modbus/RTU address of the **Modicon M171O** slave.

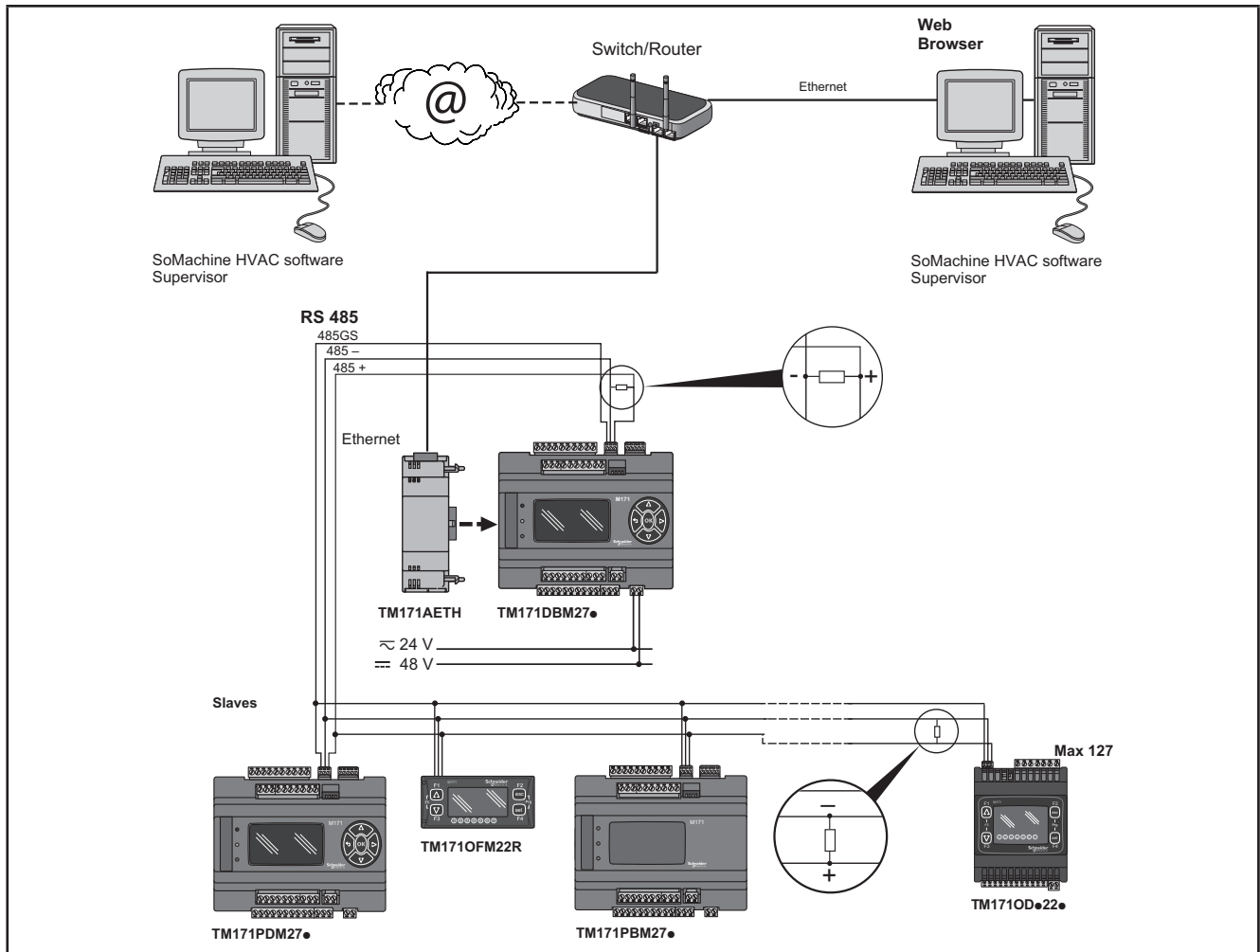

Fig. 45. BRIDGE using TM171AETH

TFTP (Trivial File Transfer Protocol)

TFTP can also be enabled for file transfer between PC and controller on an Ethernet network.

3.5.6. TM171AMB

The RS485 Communication Module allows **M171/M172** DIN rail mounted Performance controllers to communicate via an RS485 serial using a Modbus RTU Master/Slave communication protocol, in addition to the RS485 serial.

The connection allows:

- connection to a supervision system using the Modbus RTU protocol
- connection of an IEC 61131-3 **TM171SW (SoMachineHVAC)** development system
- connection to peripheral Modbus devices (for example **TM171EP●●R**)

The two CAN serials ports (integrated and communication module) offer the same level of services.

M171 Performance manages only one of the two as Modbus Master. Both can operate as a Modbus Slave.

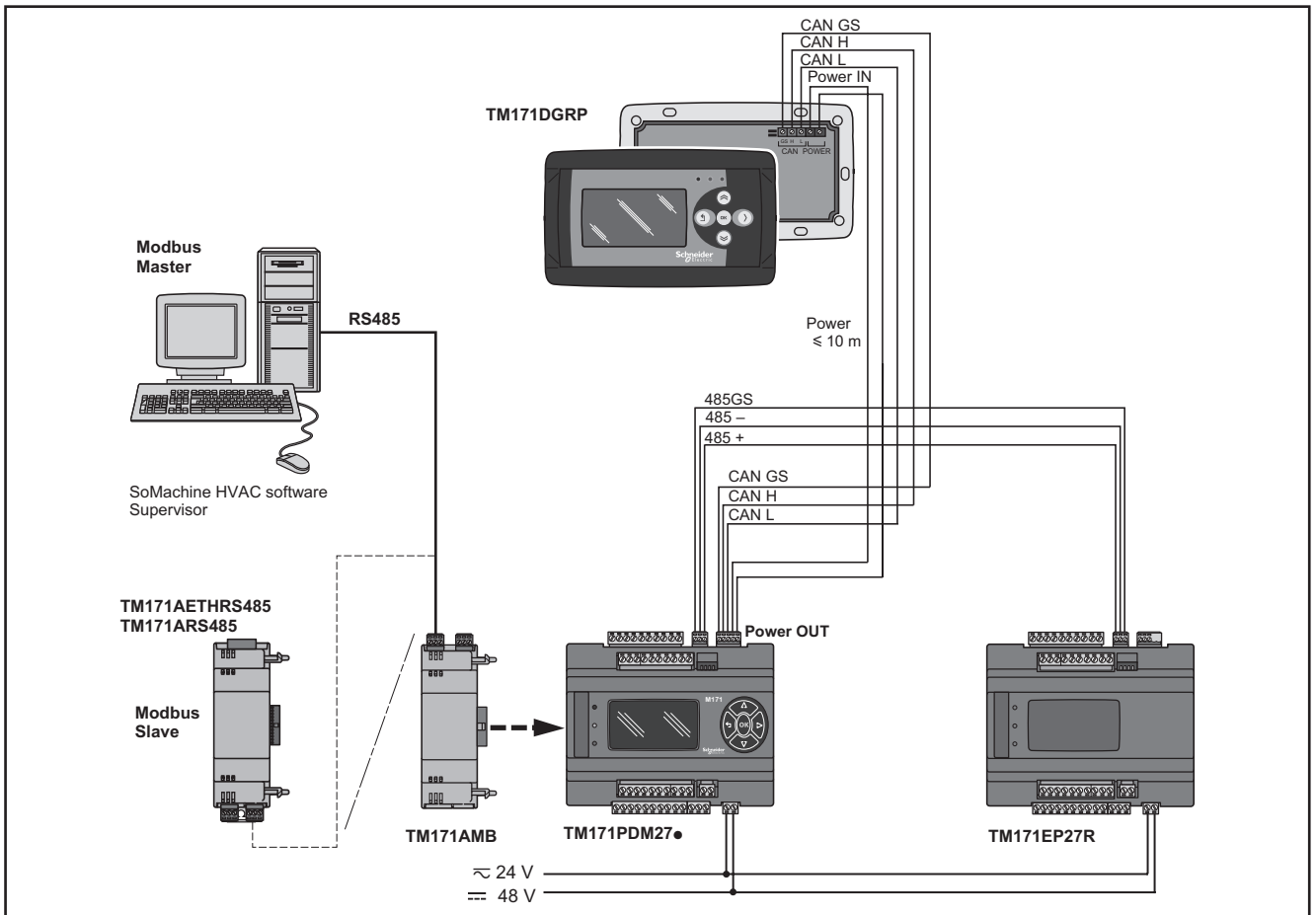

Fig. 46. Modbus RTU protocol using TM171AMB

3.5.7. TM171ARS485 / TM171AETHRS485

The connection allows **M171 Performance** controllers to connect to a BACnet supervision system using the BACnet MS/TP communication protocol.

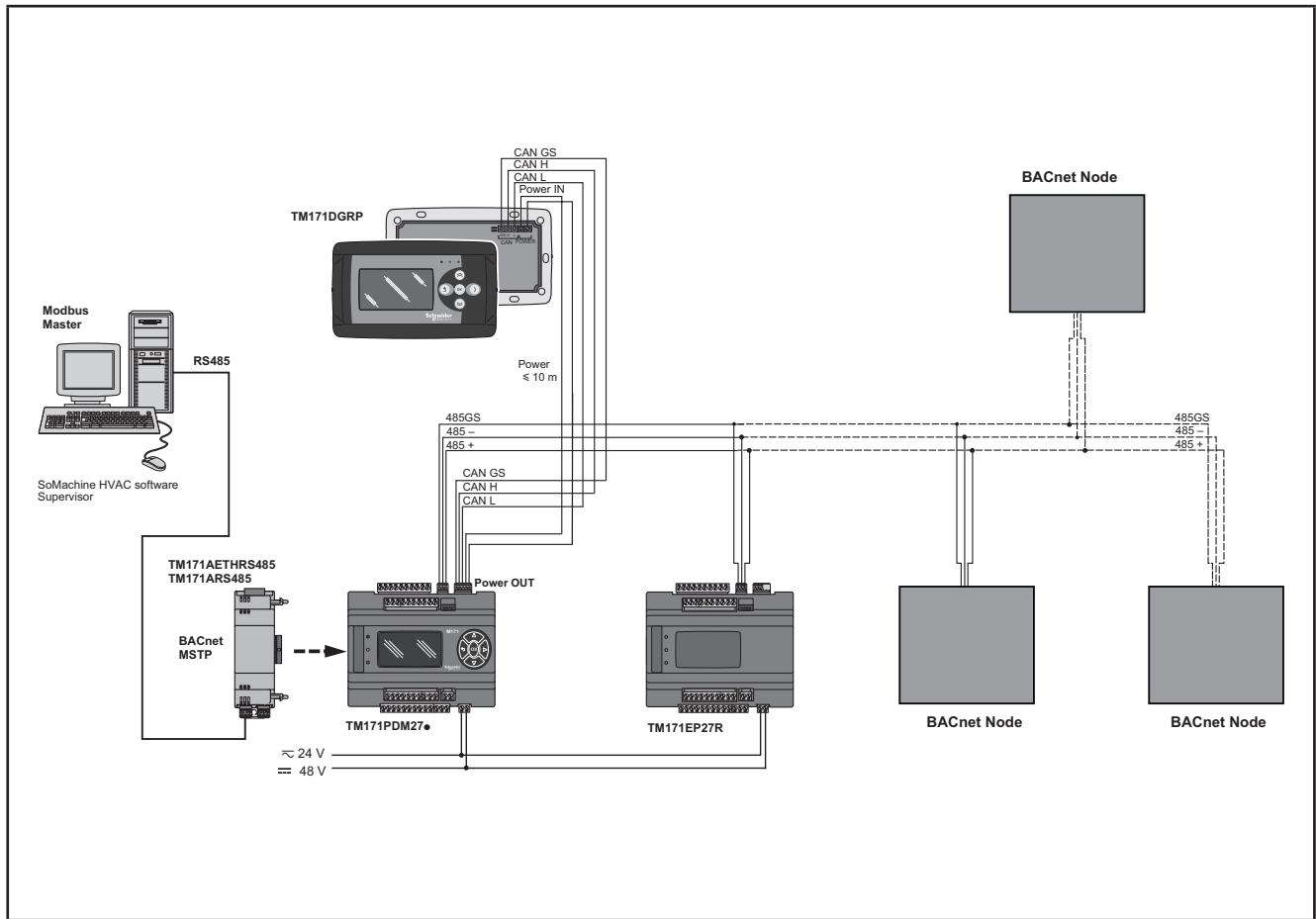

Fig. 47. BACnet MS/TP on RS 485 network using TM171ARS485 / TM171AETHRS485

3.5.8. TM171ACAN

The CAN Communication Module allows **M171/M172** DIN rail mounted Performance controllers to communicate via a CAN serial using a CAN protocol in addition to the existing CAN serial.

It allows:

- connection to a supervision system using the CAN protocol.
- connection of an IEC 61131-3 **TM171SW (SoMachineHVAC)** development system.
- connection to **TM171EP●●R** expansions.
- connection to **M171 Performance Display Graphic (TM171DGRP)** devices.

The two CAN serials ports (integrated and communication module) offer the same level of services.

M171 Performance manages only one of the two to pilot expansions.

Refer to the section on Parameters / CAN PASSIVE PLUG-IN folder (see **CHAPTER 9 Parameters on page 107**).

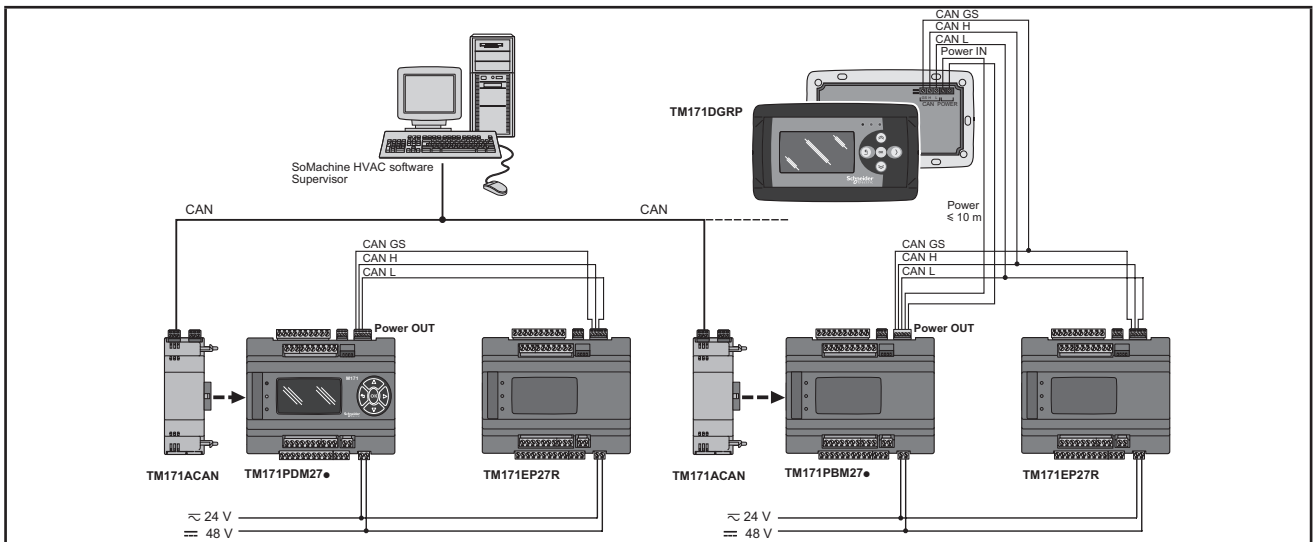

Fig. 48. CAN protocol using TM171ACAN

3.5.9. TM171APBUS

The PROFIBUS Communication Module allows **M171 Performance TM171PDM27●** and **TM171PBM27R** to communicate via a Profibus serial using the Profibus DP Slave V-0 communication profile. The connection allows interface with a supervision system or master controller using the Profibus protocol.

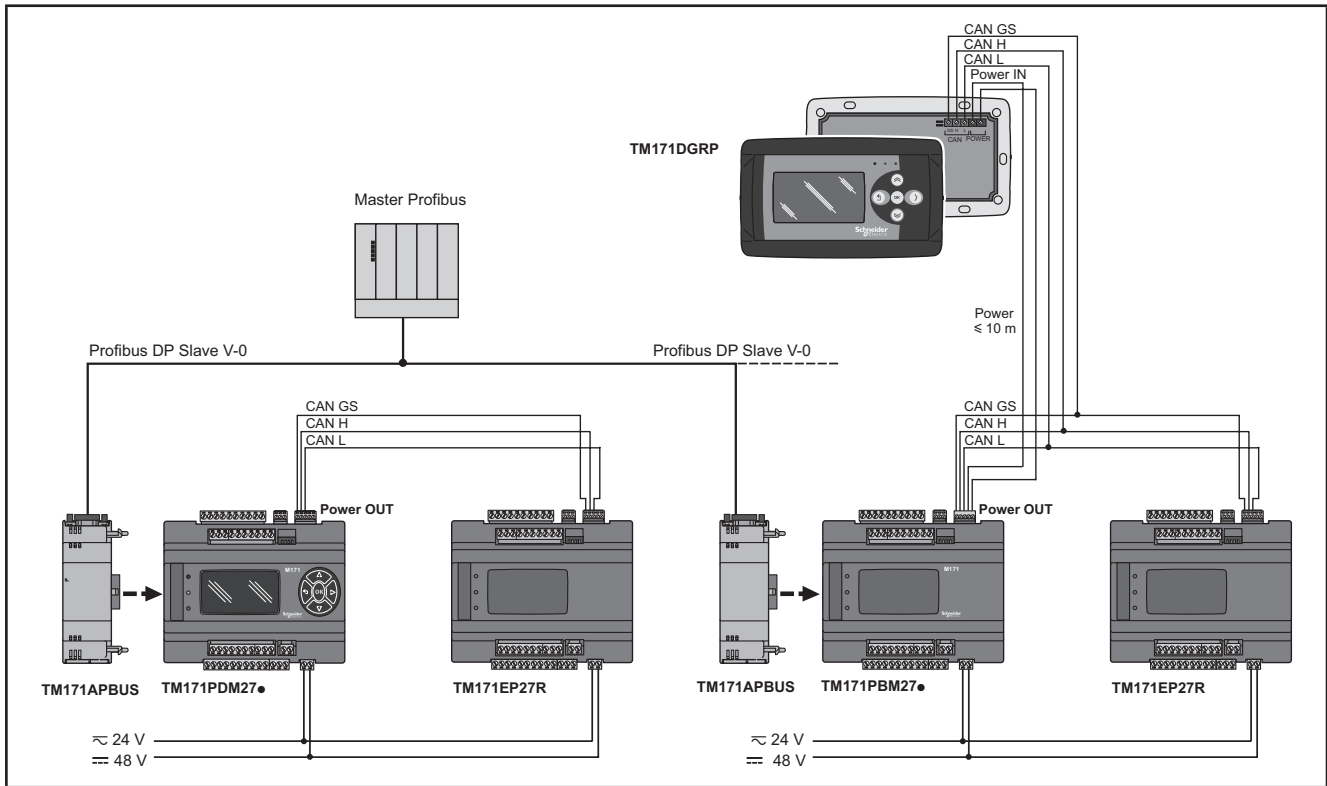

Fig. 49. Profibus protocol using TM171APBUS

3.5.10. TM171ALON

The LON Communication Module allows **M171/M172** DIN rail mounted Performance controllers to communicate via a LON serial using the LonWorks (FFT-10) communication profile.

The connection allows interface with a supervision system or master controller using the LON protocol.

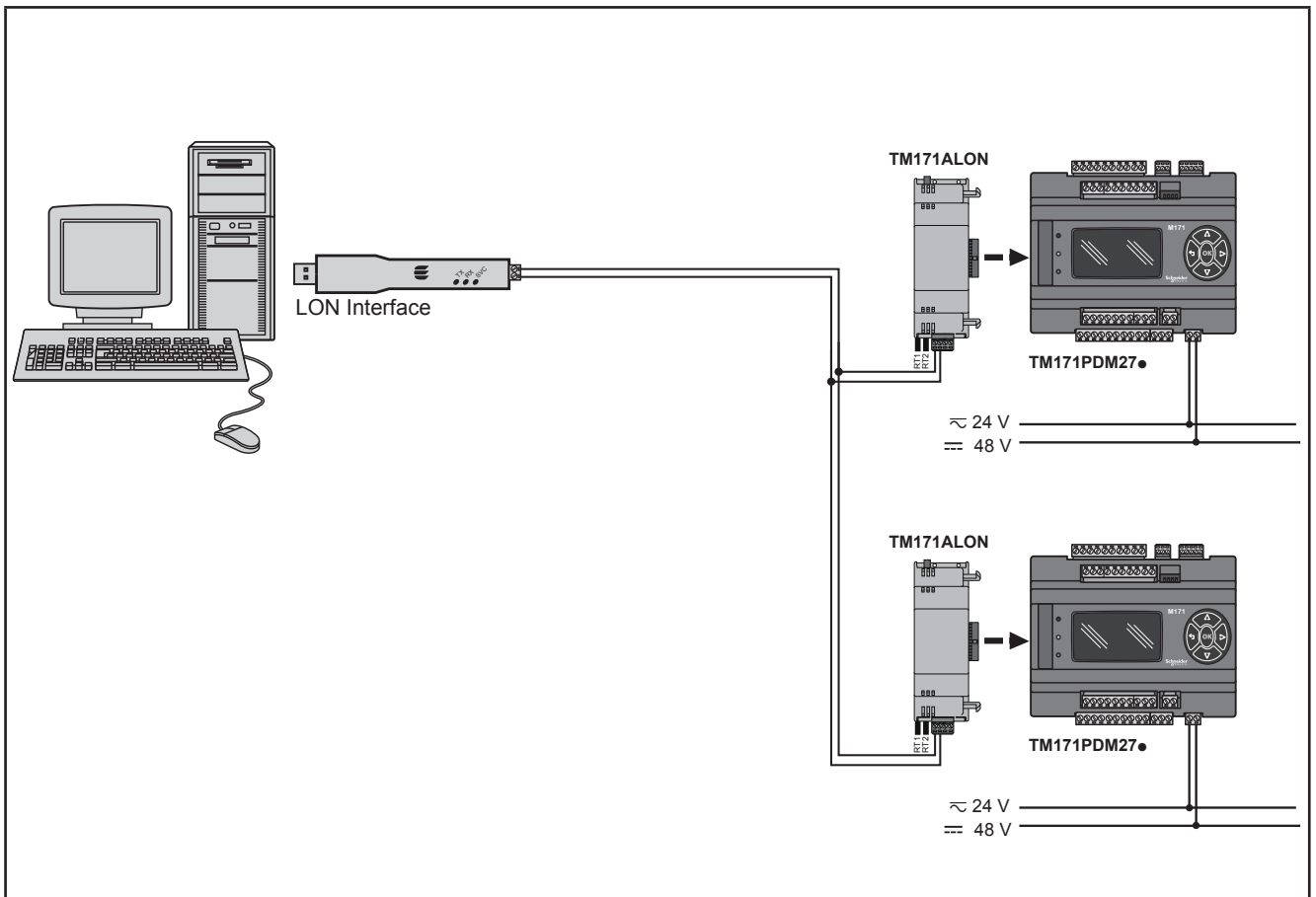

Fig. 50. LON protocol using TM171ALON

NOTE: The LonWorks communication module supports up to 63 nodes. Exceeding this specification may result in an electrical overload condition in the M171ALON Communication Module and consequently in the controller.

⚠ WARNING

UNINTENDED EQUIPMENT OPERATION

Do not exceed the maximum of 63 nodes on the TM171ALON Communication Module.

Failure to follow these instructions can result in death, serious injury, or equipment damage.

For more information on the LonWorks network, visit www.echelon.com/technology/lonwork/

3.6. Ethernet connection (for M171 Performance Flush)

The **M171 Performance Flush** product is also designated for **WebVisu**

The Ethernet connection also allows communication using HTTP protocol, i.e. access to a Web Server contained in **M171 Performance**.

TM171SW (SoMachineHVAC v2.0 or greater) allows the creation and management of web pages internally of **WebVisu (WEB SERVER HTTP)**, i.e. a website in miniature.

WEB functionalities allow local and remote access by way of an ordinary browser. Thanks to the web connection, the system provides reading, support and diagnostics services, as well as e-mail alarm alerts.

Main web functionalities:

- Web-based access.
- Remote reading and support.
- Local and remote system control, including alarms management.
- Preventive and predictive maintenance.
- Email alarm alerts.

Care must be taken and provisions made for use of this product as a control device to avoid inadvertent consequences of commanded machine operation, controller state changes, or alteration of data memory or machine operating parameters.

⚠ WARNING

UNINTENDED EQUIPMENT OPERATION

- Configure and install the mechanism that enables the remote HMI local to the machine, so that local control over the machine can be maintained regardless of the remote commands sent to the application.
- You must have a complete understanding of the application and the machine before attempting to control the application remotely.
- Take the precautions necessary to assure that you are operating remotely on the intended machine by having clear, identifying documentation within the application and its remote connection.

Failure to follow these instructions can result in death, serious injury, or equipment damage.

Refer to the section on Parameters / ETHERNET PASSIVE PLUG-IN folder (see **CHAPTER 9 Parameters on page 107**).

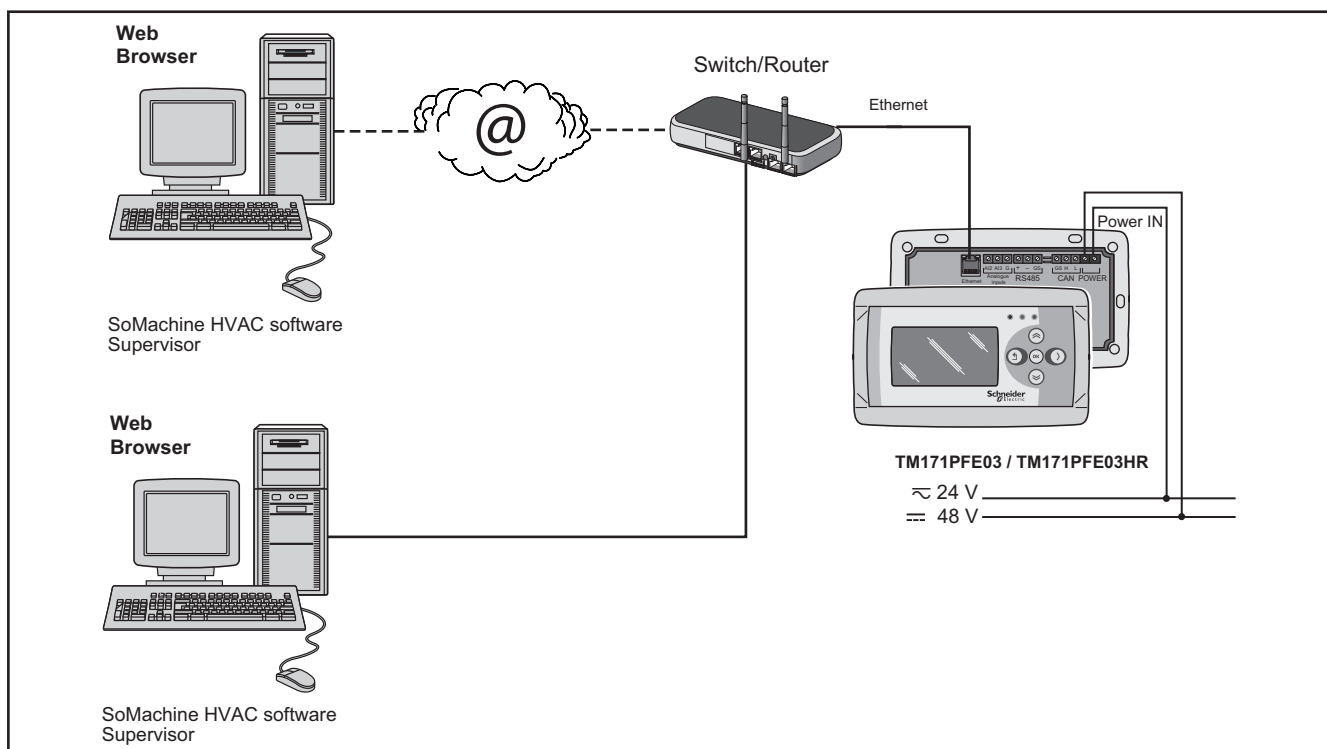

Fig. 51. WebVisu using M171 Performance Flush

BRIDGE

TM171SW (SoMachineHVAC) allows monitoring of the **Modicon M171O** or M171P controller or third party devices, typically Modbus/RTU slaves, where **WebVisu** (or **M171 Performance Flush** logic controller with Communication Module **TM171AETH**) is the Master Modbus/RTU.

In a **TM171SW (SoMachineHVAC)** project, more exactly, **WebVisu** is used as a Modbus/TCP to Modbus/RTU protocol conversion element for Modbus 0x03 and 0x10 commands.

For example from **TM171SW (SoMachineHVAC)**, set the connection with the **Modicon M171O** as Modbus/TCP, inserting the **WebVisu** IP address and the Modbus/RTU address of the **Modicon M171O** slave.

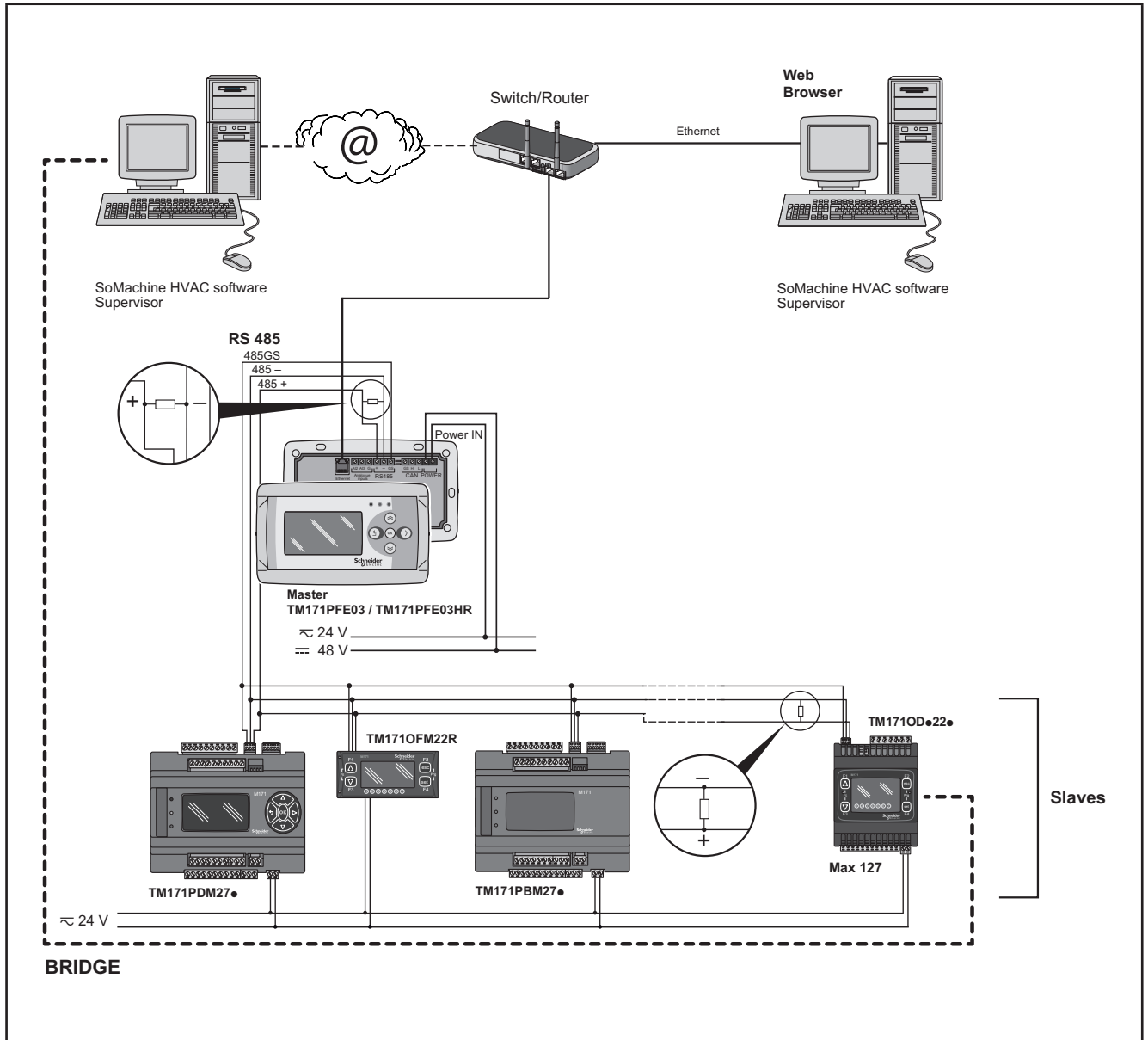

Fig. 52. WebVisu using M171 Performance Flush

TFTP (Trivial File Transfer Protocol)

TFTP (Trivial File Transfer Protocol) can also be enabled for file transfer between PC and controller on an Ethernet network.

CHAPTER 4

Technical data

All **M171 Performance logic controllers** system components meet European Community (CE) requirements for open equipment. You must install them in an enclosure or other location designed for the specific environmental conditions and to minimize the possibility of unintended contact with hazardous voltages. Use metal enclosures to improve the electromagnetic immunity of your **M171 Performance logic controllers** system. This equipment meets CE requirements as indicated in the table below.

⚠ WARNING

UNINTENDED EQUIPMENT OPERATION

Do not exceed any of the rated values specified within this chapter.

Failure to follow these instructions can result in death, serious injury, or equipment damage.

Applying incorrect current or voltage levels on analog inputs and outputs could damage the electronic circuitry. Further, connecting a current input device to an analog input configure for voltage, and vice-versa, will likewise damage the electronic circuitry.

NOTICE

INOPERABLE EQUIPMENT

- Do not apply voltages above 11 Vdc to the analog inputs of the controller or Input/Output expansion module when analog input is configured as 0-10 V input.
- Do not apply current above 30 mA to the analog inputs of the controller or Input/Output expansion module when analog input is configured as 0-20 mA or 4-20 mA input.
- Do not mismatch applied signal with analog input configuration.

Failure to follow these instructions can result in equipment damage.

4.1. General specifications

	Standard	Min	Max
Supply voltage ¹	+24 Vac/dc ±20% or +48 Vdc ±20%	21 V	60 V
Supply voltage TM171EP14R	+24 Vac/dc ±10% NOT ISOLATED	20 V	38 V
Supply frequency	50 Hz / 60 Hz	---	---
Power draw	22 VA / 18 W (M171 Performance) 16 VA / 7 W max (M171EP14R) 5 W (M171 Performance Flush and M171 Display Graphic)	---	---
Insulation class	2	---	---
Ambient operating temperature	25 °C / 77 °F	-10 °C / 14 °F	+55°C/ +131 °F
Ambient operating temperature of M171 Performance Display Graphic (TM171DGRP)	25 °C / 77 °F	-5°C / 23 °F	+55°C/ +131 °F
Ambient operating humidity (non-condensing)	30%	10%	90%
Ambient storage temperature	25 °C / 77 °F	-20 °C / -4 °F	+85°C / +185 °F
Ambient storage humidity (non-condensing)	30%	10%	90%

¹ For **M171 Performance Flush / M171 Performance Display Graphic** (TM171DGRP): powered by **M171 Performance TM171PDM27• / TM171PBM27R** or directly from an independent, properly rated power supply.

NOTE: When supplying power from the **M171 Performance logic controllers**, make the power connection cable as short as possible.

NOTICE

INOPERABLE EQUIPMENT

Do not connect a power cable longer than 10m.

Failure to follow these instructions can result in equipment damage.

Classification	
The product complies with the following harmonized regulations:	EN 60730-2-6 / EN 60730-2-9 / EN 60730-1
Use	In terms of construction, as an independently mounted temperature-sensitive automatic electronic controller
Mounting	Panel, wall or on DIN Omega bar support
Type of action	1.B – 1.Y
Pollution class	2 (normal)
Over voltage category	II
Nominal pulse voltage	2500V
Digital outputs	refer to the label on the device
Fire resistance category	D
Software class and structure	A
Type of disconnection or suspension for each circuit	Microswitch disconnection
PTI of materials used for insulation	PTI 250V
Period of electrical stress on the insulating parts	Long period

4.2. I/O features

4.2.1. M171 Performance I/O features

M171 Performance features for inputs and outputs.

Type and Label	No.	Description	TM171PDM27R TM171PBM27R TM171EP27R	TM171PDM27S
Digital input DI1...DI8	8	8 opto-isolated digital inputs Working voltage +24 Vac/dc $\pm 20\%$ or +48 Vdc $\pm 20\%$ Power draw max. 5 mA Digital inputs can be used as pulse counters. The length of the pulse (positive or negative) must be greater than 12 ms. See CHAPTER 8 Physical I/O and ports configuration on page 92.	✓	✓
Digital input FAST DI	1	1 no-voltage digital input (Pulse count + Read frequency) Note: measure a signal with a maximum frequency of 1 kHz See CHAPTER 8 Physical I/O and ports configuration on page 92.	✓	✓
Relay digital outputs High voltage DO1, DO2	7	2 x 8 A 250 Vac relays	✓	-
Relay digital outputs High voltage DO3...DO7		5 x 5 A 250 Vac relays	✓	-
Relay digital outputs High voltage DO1, DO2	5	2 x 8 A 250 Vac relays	-	✓
Relay digital outputs High voltage DO5, DO6, DO7		3 x 5 A 250 Vac relays	-	✓
SSR digital outputs High voltage DO3, DO4	2	2 x 1 A 250 Vac SSR	-	✓
Analog outputs AO1...AO5	5	5 x 0-10 V / 4..20mA / ON-OFF configurable outputs: <ul style="list-style-type: none"> • 0..10V 2% full scale Min.load 500 Ω; 1% full scale with load greater than 5 kΩ • 4...20mA 2% full scale max. 400 Ω • ON-OFF Max.load 400 Ω Note: AO4 and AO5 can be configured as Open Collector. See CHAPTER 8 Physical I/O and ports configuration on page 92.	✓	✓
Analog inputs AI1 AI2 AI3 AI4 AI5 AI6	6	See the following table	✓	✓

	NTC (NK103) 10 kΩ at 25 °C (77 °F) BETA value 3435	DI (1)	NTC (103AT-2) 10 kΩ at 25 °C (77 °F) BETA value 3435	4-20 mA	0-10 V
AI1	✓	✓	✓	-	-
AI2	✓	✓	✓	-	-
AI3	✓	✓	✓	✓	✓
AI4	✓	✓	✓	✓	✓
AI5	✓	✓	✓	✓	✓
AI6	✓	✓	✓	✓	✓
Range	-40...+150 °C (-40...+302 °F)	-	-50...+110 °C (-58...+230 °F)	0...1000	0...1000
Accuracy	0.5% full scale + 1 digit	-	0.5% full scale + 1 digit	1% full scale + 1 digit	1% full scale + 1 digit
Resolution	0.1 °C	-	0.1 °C	1 digit	1 digit
Input impedance	10 kΩ	20 kΩ	10 kΩ	100 Ω	21 kΩ

(1) DI Digital Input: voltage free digital input.

	0-5 V Ratiometric (1)	PT1000	hΩ (NTC)	daΩ (PT1000)
AI1	-	-	-	-
AI2	-	-	-	-
AI3	✓	✓	✓	✓
AI4	✓	✓	✓	✓
AI5	✓	✓	✓	✓
AI6	✓	✓	✓	✓
Range	0...1000	-200...+800 °C (-328...+1472 °F)	0...150 kΩ	0...30 kΩ
Accuracy	1% full scale + 1 digit	0.5% full scale + 1 digit	1% full scale + 1 digit	1% full scale + 1 digit
Resolution	1 digit	0.1 °C	1 hΩ	1 daΩ
Input impedance	21 kΩ	2 kΩ	10 kΩ	2 kΩ

(1) 0-5 V Ratiometric. 50 mA maximum current at 5 V

Also see [8.1.1. Analog inputs configuration for M171 Performance on page 93](#) for instructions on offsets and calibrations.

4.2.2. M171EP14R Performance I/O features

M171EP14R Performance features for inputs and outputs.

Type and Label	No.	Description	TM171EP14R
Digital input DI1...DI4	4	4 digital inputs NOT ISOLATED Working voltage 24 Vac/dc $\pm 10\%$ (Vac: max 38Vac) Power draw max. 5mA	✓
Relay digital outputs High voltage DO1...DO4	4	1 x 5A 250 Vac SPDT relay 3 x 3A 250 Vac SPST relays (common max 10A)	✓
Analog outputs AO1...AO2	2	2 x 0-10 V outputs: 4% full scale Min.load 5K Ω ; 2% full scale with load greater than 5K Ω	✓
Analog inputs AI1 AI2 AI3 AI4	4	See the following table	✓

	NTC (NK103) 10 k Ω at 25 °C (77 °F) BETA value 3435	DI (1)	NTC (103AT-2) 10 k Ω at 25 °C (77 °F) BETA value 3435	4-20 mA	0-10 V
AI1	✓	✓	✓	-	-
AI2	✓	✓	✓	-	-
AI3	✓	✓	✓	✓	✓
AI4	✓	✓	✓	✓	✓
Range	-40...+137 °C (-40...+278.6 °F)	-	-50...+110 °C (-58...+230 °F)	0...1000	0...1000
Accuracy	0.5% full scale + 1 digit	-	0.5% full scale + 1 digit	1% full scale + 1 digit	1% full scale + 1 digit
Resolution	0.1 °C	-	0.1 °C	1 digit	1 digit
Input impedance	10 k Ω	10 k Ω	10 k Ω	<200 Ω	>10 k Ω

(1) DI Input: voltage free digital input.

	0-5 V (1)	PT1000	h Ω (NTC)	da Ω (PT1000)	PTC (KTY81)
AI1	-	-	-	-	✓
AI2	-	-	-	-	✓
AI3	✓	✓	✓	✓	✓
AI4	✓	✓	✓	✓	✓
Range	0...1000	-200...+295 °C (-328...+563 °F)	0..150 k Ω	0...30 k Ω	-50°C ..+150 °C (-58...+302 °F)
Accuracy	1% full scale + 1 digit	0.5% full scale + 1 digit	1% full scale + 1 digit	1% full scale + 1 digit	0.5% full scale + 1 digit
Resolution	1 digit	0.1 °C	1 h Ω	1 da Ω	0.1 °C
Input impedance	>20 k Ω	2 k Ω	10 k Ω	2 k Ω	2 k Ω

(1) Ratiometric. 50 mA maximum current at 5 V

Also see [8.1.1. Analog inputs configuration for M171 Performance on page 93](#) for instructions on offsets and calibrations.

4.2.3. M171 Performance Flush I/O features

M171 Performance Flush features for inputs.

Type and Label	Probe	Description	Resolution	Accuracy	Measurement range	Impedance	TM171PFE03	TM171PFE03HR
Analog inputs								
AI1	On-board	NTC	0.1 °C / °F	0.5% full scale + 1 digit	-	10 kΩ	✓	✓
AI2 configurable	Remote	NTC 103AT	0.1 °C / °F	0.5% full scale + 1 digit	-50...+110 °C (-58...230 °F)	10 kΩ		
	NOT included	NTC NK103	0.1 °C / °F	0.5% full scale + 1 digit	-40...+150 °C (-40...302 °F)	10 kΩ	✓	✓
		D.I.(1)	-	-	-	20 kΩ		
AI3 configurable	Remote	4...20 mA	1 digit	1% full scale + 1 digit	0...1000	100 Ω	✓	-
	NOT included	0-5 V (2)	1 digit	1% full scale + 1 digit	0...1000	21 kΩ	-	-
		0..10 V	1 digit	1% full scale + 1 digit	0...1000	21 kΩ	-	-
AI4	On-board	On-board %RH input	0.01 %RH (0%=0pt, 100% = 1000pt)	±3% [20...80%] ±5% ...elsewhere	0-100 %RH	-	-	✓

(1) D.I. Digital Input voltage-free.

(2) 50 mA maximum current at 5 V.

Also see [8.1.2. Analog inputs configuration for M171EP14R on page 94](#) for instructions on offsets and calibrations.

4.3. Display

M171 Performance TM171PDM27 references, remote display and **M171 Performance Flush**:

- backlit with LEDs
- 3 LEDs

LEDs and backlighting can be controlled from application.

4.3.1. M171 Performance Display Graphic / M171 Performance Flush display

Display	Monochromatic LCD graphic display 128x64px backlit with LEDs
Container	Backplate + frame in PC+ABS UL94 V-0 plastic resin, transparent polycarbonate front cover, polyester membrane keypad

4.4. Serials

Serial	Description	Notes	References
CAN	CAN Expansion Bus	max 50 m at 500 kpbs; 200 m at 125 kpbs.	TM171P●●●● TM171EP●●R M171 Performance Display Graphic (TM171DGRP)
		If necessary, apply a 120 Ω termination resistor to both the ends.	
RS 485	2 x RS 485 serial	If the controller is connected at the end of the RS 485 communication line, apply a 120 Ω termination resistor between line + and line - of the RS 485	TM171P●●●● TM171EP27R
		Only one RS 485 serial port can be configured as Modbus master at the same time.	
USB	1 Type A USB female connector (Host)	'Mass Storage' profile External memory, FAT32 formatting.	TM171P●●●●
	1 Type mini-B USB female connector (Device)	Connection between PC and device through USB standard CDC profile.	
ETHERNET	Modbus TCP ETHERNET port	Equipment includes MACADDRESS, in barcode and 12-digit alphanumeric format.	M171 Performance Flush

Pay special attention when connecting serial lines. Miswiring may lead to inoperable equipment.

NOTICE

INOPERABLE EQUIPMENT

- Do not connect equipments that communicate using RS 485 serial to CAN Expansion Bus terminals.
- Do not connect equipments that communicate using CAN Expansion Bus to RS 485 terminals.

Failure to follow these instructions can result in equipment damage.

4.4.1. TM171A●●●● Communication Module

	Serial	Notes	Terminals
TM171ARS232	RS232 Nullmodem	Digital outputs 1 x SPDT 5 A 250 Vac relay	terminals 1...3 screw type removable, spacing 5, 90° insertion for cables with 2.5 mm ² cross-section. + DB9 connector
TM171ACAN	Double serial port	Opto-isolated CAN serial	removable screw type , spacing 3.81, 90° insertion for cables with 2.5 mm ² cross-section.
TM171AMB TM171ARS485	Double serial port	Opto-isolated RS485 serial	removable screw type , spacing 3.81, 90° insertion for cables with 2.5 mm ² cross-section.
TM171AETH	Modbus TCP ETHERNET port	-	RJ45 connector
TM171AETHRS485	Modbus TCP ETHERNET port Double serial port	Opto-isolated RS485 serial	RJ45 connector removable screw type , spacing 3.81, 90° insertion for cables with 2.5 mm ² cross-section.
TM171ALON	LON	-	-
TM171APBUS	Profibus DP Slave-V0	-	-

4.5. Power supply

The **M171 Performance logic controllers** and associated devices require power supplies with a nominal voltage of 24 Vac / 24 Vdc or 48 Vdc. The power supplies/transformers must be rated Safety Extra Low Voltage (SELV) according to IEC 61140. These sources of power are isolated between the electrical input and output circuits of the power supply as well as simple separation from ground (earth), PELV and other SELV systems.

DANGER

GROUND LOOP CAUSING ELECTRIC SHOCK AND/OR INOPERABLE EQUIPMENT

- Do not connect the 0 V power supply/transformer connection supplying this equipment to any external ground (earth) connection.
- Do not connect any 0 V or ground (earth) of the sensors and actuators connected to this equipment to any external ground connection.
- If necessary, use separate power supplies/transformers to power sensors or actuators isolated from this equipment.

Failure to follow these instructions will result in death or serious injury.

If the specified voltage range is not maintained, or the effective separation of the SELV circuit connected to the concerned equipment is compromised, the products may not function as intended or may become damaged and inoperable.

WARNING

POTENTIAL OF OVERHEATING AND FIRE

- Do not connect the equipment directly to line voltage.
- Use only isolating SELV power supplies/transformers to supply power to this equipment.

Failure to follow these instructions can result in death, serious injury, or equipment damage.

The equipment must be connected to a suitable power supply/transformers with the following features:

Primary voltage	Depending on requirements of the individual device and/or country of installation.
Secondary voltage	+24 Vac/dc $\pm 20\%$ or +48 Vdc $\pm 20\%$
Power supply frequency Vac	50/60 Hz
Power	minimum 18 W (M171 Performance) minimum 5 W (M171 Performance Flush)

4.6. Mechanical dimensions

	Length (L) <u>mm</u> in	Depth (d) <u>mm</u> in	Height (H) <u>mm</u> in	Notes
M171 Performance TM171PDM27● / TM171PBM27R / TM171EP27R	<u>140</u> 5.51	<u>61.6</u> 2.42	<u>110</u> 4.33	-
M171 Performance TM171EP14R	<u>70</u> 2.75	<u>61.6</u> 2.42	<u>87</u> 3.42	-
TM171A●●●● Communication Module	<u>35</u> 1.38	<u>61.6</u> 2.42	<u>110</u> 4.33	-
M171 Performance Display Graphic (TM171DGRP) M171 Performance Flush	<u>160</u> 6.3	<u>10</u> 0.39	<u>96</u> 3.8	-
Opening for panel-mounting of M171 Performance Display Graphic (TM171DGRP) or M171 Performance Flush	<u>138</u> 5.43	-	<u>68</u> 2.68	(+0.2mm / -0.1mm)

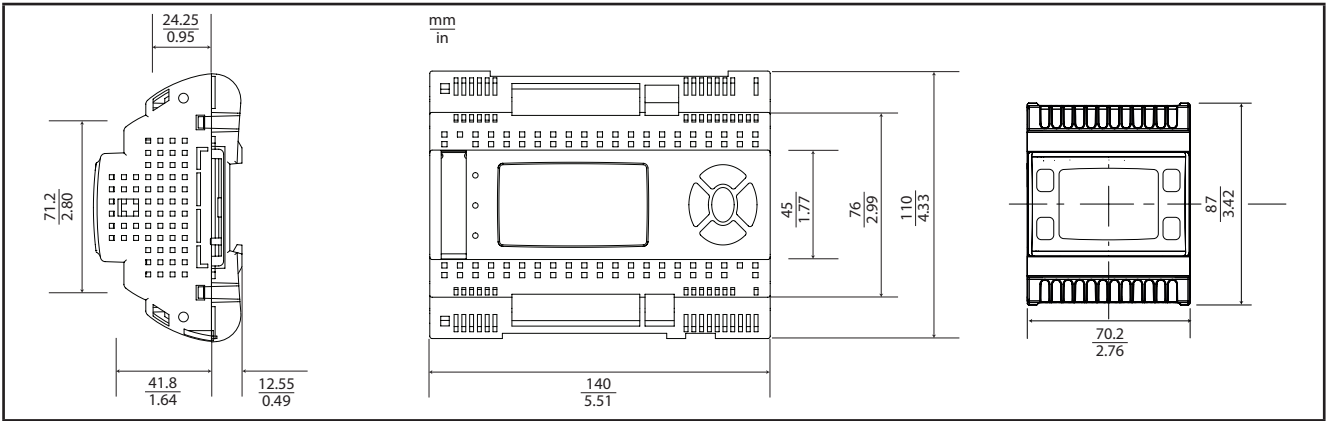

Fig. 53. TM171PDM27● / TM171PBM27R / TM171EP27R / TM171EP14R

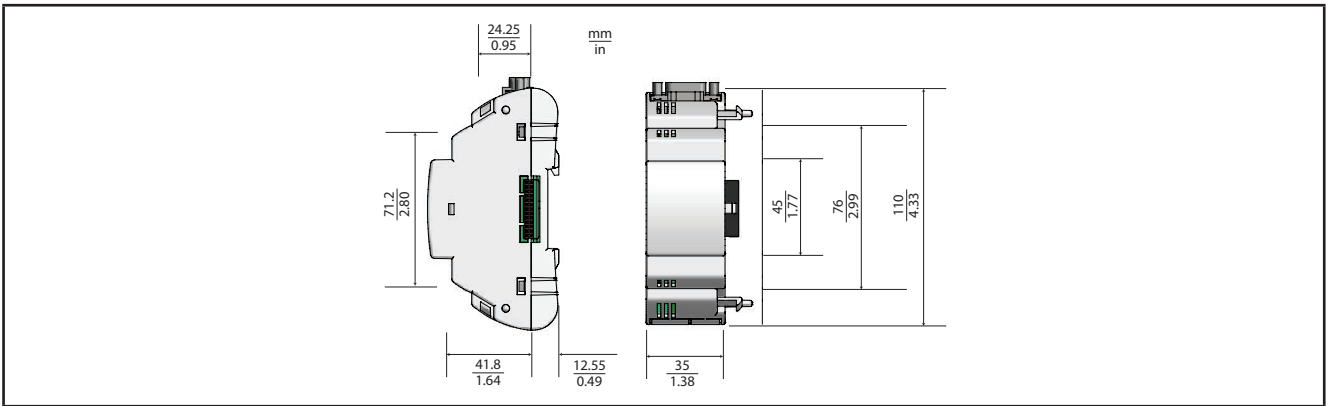

Fig. 54. TM171A●●●

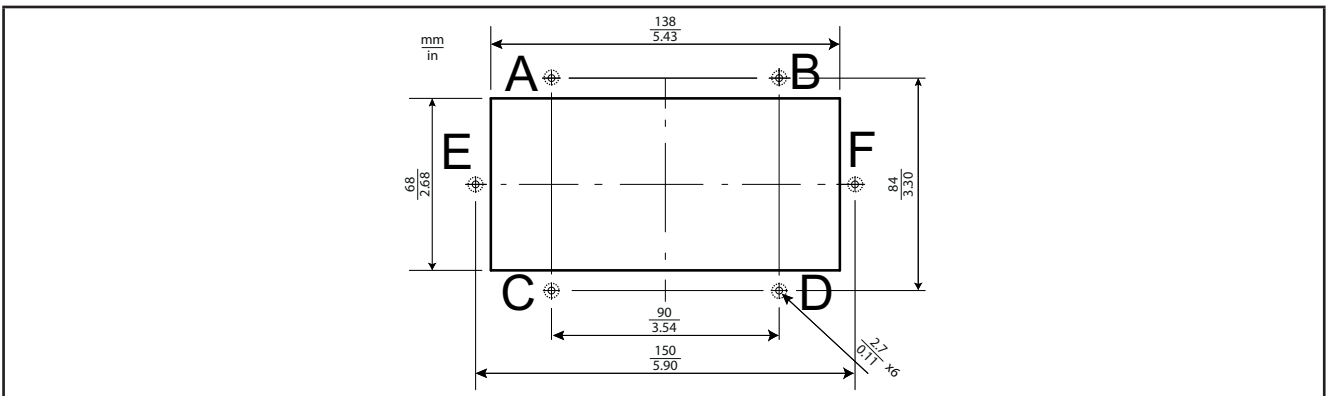

Fig. 55. Panel opening dimensions for M171 Performance Display Graphic (TM171DGRP) or M171 Performance Flush

CHAPTER 5

M171 Performance User Interface

The interface, comprising the front cover of the controller, allows you to perform operations to use the device.

5.1. Keys and LEDs

The data provided for keys refers to **TM171PDM27●** references.

The **TM171PBM27R** module has no display. Use the **M171 Performance Display Graphic (TM171DGRP)** to work on this controller.

The **TM171EP●●R** expansion module has no display.

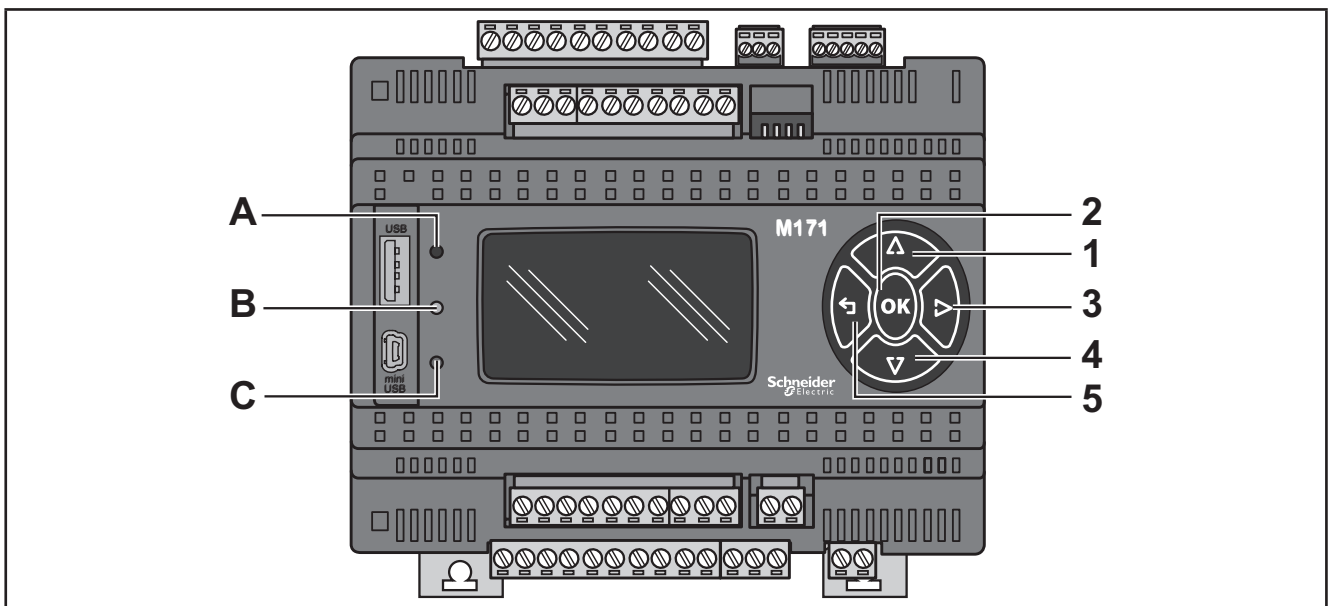

Fig. 56. TM171PDM27●

The keys can be programmed from the controller application. By default, the device displays a short menu containing the following default settings.

No.	Key	Press once (press and release)
1	△ UP	<ul style="list-style-type: none"> • Scroll up • Increase/modify a value • Go to next label
2	OK	<ul style="list-style-type: none"> • Scroll down • Move to next level/menu (open folder, subfolder, parameter, value) • Enter/exit Edit mode • Confirm operation
3	RIGHT ▷	<ul style="list-style-type: none"> • Move cursor to right in Edit Mode
4	DOWN ▽	<ul style="list-style-type: none"> • Scroll down • Decrease/modify a value • Go to previous label
5	↶ Exit	<ul style="list-style-type: none"> • Exit menu page / go back to previous menu • Move cursor to left in Edit Mode • (press and hold) Exit Edit Mode without saving

The LEDs can be programmed from the application.

By default, they are used for USB management - see the relative section on USB-Handling (see [3.1.6. Serial connections on page 27](#)).

LEDs	Description
A B C	A, B and C LEDs are programmable via controller application

5.2. First power on

When the equipment is powered on for the first time, a few summary pages are displayed showing system status (**SYSTEM INFO**).

SYSTEM INFO
HW
BIOS
DATE
BOOT
EEPROM

NOR FLASH	OK
NAND FLASH	OK
SDRAM	OK
BATRAM	OK
RTC	OK
Plug-in	None
USB-H	OK
USB-D	Service area

5.3. Menu

M171 Performance has a minimal system menu to configure inputs/outputs, display I/O values and USB operations where present (**TM171PDM27** references).

The User interface is available in English only.

5.3.1. System Menu

System Menu
BIOS Configuration
BIOS I/O Values
BIOS RTC Values
USB-Host Handling

5.3.2. BIOS Configuration

Parameter configuration menu. See **CHAPTER 9 Parameters on page 107**.

BIOS Configuration
Analog Input
Analog Output
On-board RS485
On-board CAN

The table below lists the parameters that can be configured from the LCD display (**TM171PDM27•** reference) and/or **M171 Performance Display Graphic** (TM171DGRP).

The menu for parameter configuration is **System Menu > BIOS Configuration**.

BIOS Configuration	Parameter Folder
Analog Input	ANALOG INPUTS
Analog Output	ANALOG OUTPUTS V/I
On-board RS485	On-board RS485
On-board CAN	On-board CAN

5.3.3. BIOS I/O Values

Shows input (read only) and output values (modifiable).

BIOS I/O Values
Analog Input
Analog Output
Digital Output
Digital Input

Inputs are read only. Digital input example:

Digital Input	
DI1 Off	DI5 Off
DI2 Off	DI6 Off
DI3 Off	DI7 Off
DI4 Off	DI8 Off

The analog and digital outputs are modifiable.

Move the cursor to the resource required.

Press the **OK** key to enter Edit Mode. Use the **UP** and **DOWN** keys to modify value. Confirm with the **OK** key.

Analog output example.

Analog Output 1/2	
AO1 0.2 %	
AO2 0.0 %	
AO3 0.0 %	
V Prev	Next ^

Digital Output example.

Digital Output	
DO1 On	DO5 Off
DO2 Off	DO6 Off
DO3 Off	DO7 Off
DO4 Off	

5.3.4. BIOS RTC Values

Shows time (HH : MM : SS) and date (DD / MM / YY) internal clock.

BIOS RTC Values
16 : 50 : 56
30 / 10 / 10
RTC set

Press **OK**.

Select the value that you want to modify.

Press the **OK** key to enter Edit Mode. Use the **UP** and **DOWN** keys to modify value. Confirm with the **OK** key.

Go to RTC "Update" and press **OK** to update the clock.

BIOS RTC Values
17 : 50 : 56
31 / 10 / 10
RTC update

5.3.5. USB-Host Handling

This menu provides options to work on project files.

Type A USB (HOST) - USB memory key.

USB-Host Handling
USB--> M171 PERFORMANCE
M171 PERFORMANCE--> USB

NOTE: Only use one USB connection at a time.

Menu description

M171 PERFORMANCE --> USB

Menu that allows you to download parameters to the USB memory key.

This should only be done for BIOS parameters:

- **Parameters**

USB -> M171 PERFORMANCE

Menu that allows you to upload parameters, applications and menus from a USB memory key to **M171 PERFORMANCE**. The operation should be done individually for each **TM171SW (SoMachineHVAC)** development file and for BIOS parameters:

- **Application**
- **User Interface**
- **Connection**
- **Parameters**

Preliminary operations

1. Check USB memory key

- Connect the USB to the PC.
- Check that it has been FAT32 formatted
- Select Computer.
- Right click the external drive.
- Select Properties and check System File type: FAT32.

2. Create PARAM.DAT file

Use this menu:

M171 PERFORMANCE --> USB

- Connect the USB memory key.
- Select M171 PERFORMANCE --> USB.
Parameters is the only available option.

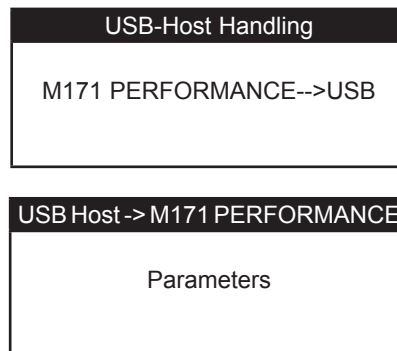

On completion, the USB memory key will contain the **PARAM.DAT** file.

3. Copy file from M171 PERFORMANCE to PC

Type mini-B USB (DEVICE)

Connect **M171 Performance** to a PC or third party device using a suitable USB mini-B cable.

This can be done from a PC or other device.

M171 Performance supplies the following files to be copied to PC and then transferred to a USB memory key:

File	Development environment	Description	Note
HMIIEC.COD	User Interface	Menu	Available after M171 Performance has been rebo- oted
PLCIEC.COD	Application	Controller application	
CONNEC.PAR	Connection	Network configuration file	

4. UPLOAD.TXT file creation

The UPLOAD.txt file can be created by any text editor with the following contents:

Example: files in UPLOAD.txt

Example UPLOAD.txt	Example 03UPLOAD.txt
<code>; Application PLCIEC.COD</code>	<code>; Application 03PLCIEC.COD</code>
<code>; User Interface HMIIEC.COD</code>	<code>; User Interface 03HMIIEC.COD</code>
<code>; Connection CONNEC.PAR</code>	<code>; Connection 03CONNEC.PAR</code>
<code>; Parameters PARAM.DAT</code>	<code>; Parameters 03PARAM.DAT</code>
<code>; User Interface Remote HMIREM.KBD</code>	<code>; User Interface Remote 03HMIREM.KBD</code>

The remote interface, if available, can also be added to each file.

When more than one **M171 Performance** is being used, use dipswitches for updating.

File names will be preceded by 00, 01, 02, 03 etc and **M171 Performance** will only load the relative file if it matches the dipswitch setting.

Example: 4 files on USB memory key

The file **HMIIEC.COD** and **00HMIIEC.COD** are identical.

Files on USB	Dipswitch M171 Performance	Description	Note
HMIIEC.COD	00	Parameter file downloaded to M171 Performance	See previous example
00HMIIEC.COD	01	Parameter file NOT downloaded to M171 Performance	
01HMIIEC.COD	01	Parameter file downloaded to M171 Performance	
02HMIIEC.COD	01	Parameter file NOT downloaded to M171 Performance	
02HMIIEC.COD	02	Parameter file downloaded to M171 Performance	

Example: 1 file on USB memory key

Files on USB	Dipswitch M171 Performance	Description	Note
02HMIIEC.COD	01	Parameter file NOT downloaded to M171 Performance	Message "file not present" displayed.

5. Transfer file to USB memory key

The following files will be saved to the USB memory key:

File	Development environment	Description	Note
HMIIEC.COD	User Interface	Menu	The remote interface, if available, can also be added. Available after M171 Performance has been rebooted
PLCIEC.COD	Application	Controller application	Available after M171 Performance has been rebooted
CONNEX.PAR	Connection	Network configuration file	
PARAM.DAT	Parameters	Parameters	Type A USB (HOST) Instant update without having to reboot
UPLOAD.TXT	/	"boot" file needed to upload parameters.	The UPLOAD.TXT file must be on the USB memory key

You can now use the following menu:

USB --> M171 PERFORMANCE

- Connect the USB memory key.
- Select USB -> M171 PERFORMANCE
- Select the required option.

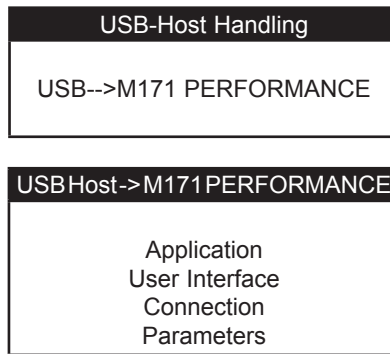

If the action completes successfully, the following screens are shown:

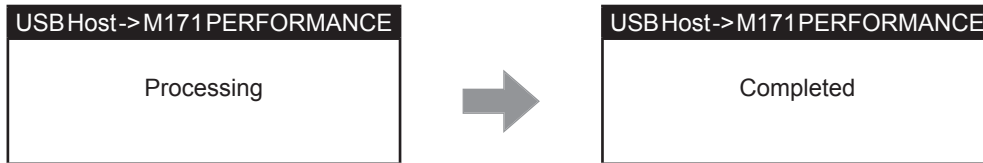

If the file is not found, the following message will be displayed:

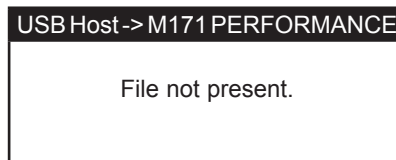

If there is no USB memory key, the following message will be displayed:

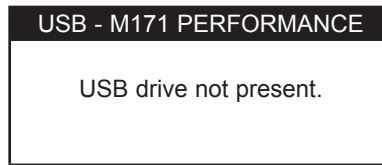

File management not using the menu

Alternatively, files can be downloaded automatically without using the menu or display (**TM171PBM27R** reference).

NOTE: The UPLOAD.TXT file must be on the USB memory key (USB drive).

Connect the USB memory key.

The files on the USB memory key will be transferred automatically to **M171 Performance**.

At the user interface level, the LEDs will behave as follows:

LED		Upload
Red	Flashing 2 seconds	Operation unsuccessful
Yellow	On	Underway
Green	Flashing 2 seconds	Completed successfully

When the LEDs have gone off, the USB memory key can be removed.
Switch off or restart the controller and make the data download effective.

CHAPTER 6

M171 Performance Display Graphic user interface

The interface, comprising the front cover of the controller, allows you to perform operations to use the device.

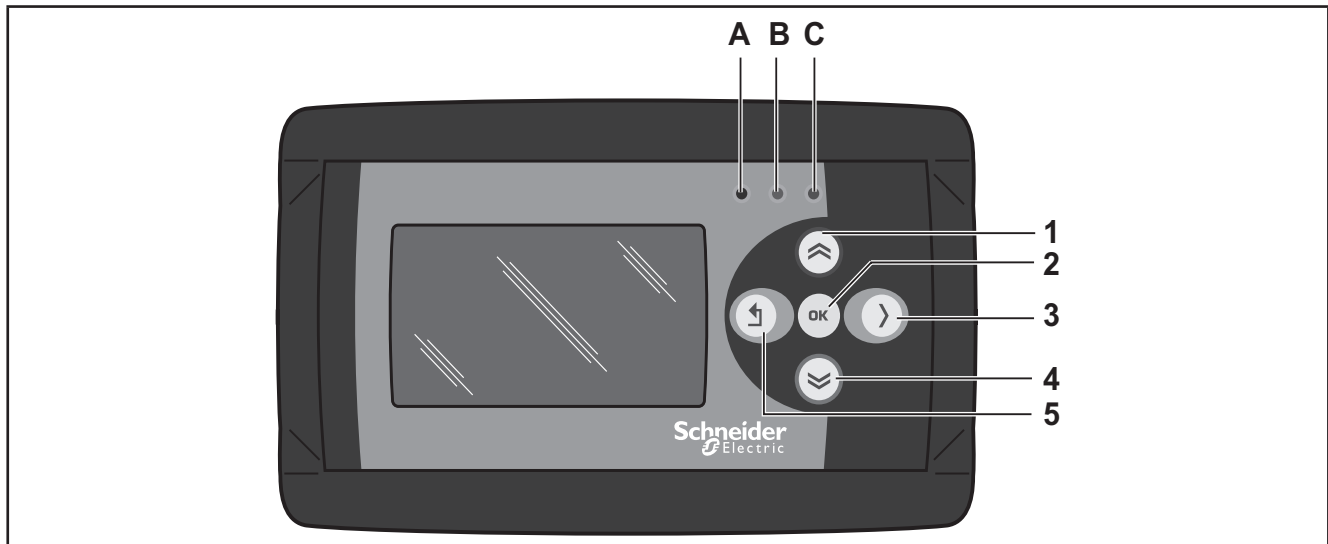





Fig. 57. M171 Performance Display Graphic (TM171DGRP)

6.1. Keys and LEDs

The keys can be programmed from the controller application. By default, the device displays a short menu containing the following default settings.

No.	Key	Press once (press and release)
1	 UP	<ul style="list-style-type: none"> • Scroll up • Return to previous page (for example 1/3 ←2/3) • Increase / modify a value • Go to next label
2	OK	<ul style="list-style-type: none"> • Scroll down • Move to next level/menu (open folder, subfolder, parameter, value) • Enter/exit Edit mode • Confirm operation
3	RIGHT 	<ul style="list-style-type: none"> • Move cursor to right in Edit Mode
4	DOWN 	<ul style="list-style-type: none"> • Scroll down • Move to the next page (for example 1/3→2/3) • Decrease / modify a value • Go to previous label
5	 Exit	<ul style="list-style-type: none"> • Exit menu page / go back to previous menu • Move cursor to left in Edit Mode • (press and hold) Exit Edit Mode without saving

DIAGNOSTICS Menu

M171 Performance Display Graphic (TM171DGRP) is factory-configured with a default DIAGNOSTICS (DIA) menu that appears when the equipment is powered on.

After uploading a controller application and/or a HMI menu from **TM171SW (SoMachineHVAC)**, the main display consists of the application menu created with **TM171SW (SoMachineHVAC)** Interface.

In which case, to open the DIAGNOSTICS menu proceed as follows:

No.	Key combination	Press and hold for about 3 seconds
4+5	DOWN	Open DIAGNOSTICS menu
	↵ Exit	

To return to the controller application menu, open the “HMI Management” page, select ↵ and press the **OK** key.

See [6.4. Remote interface on page 84](#).

The LEDs can be programmed from the controller application.

LEDs	Description
A B C	A, B and C LEDs are programmable via controller application

6.2. First power on

When the equipment is powered on for the first time, a few summary pages are displayed showing system status (**SYSTEM INFO**).

SYSTEM INFO
HW
BIOS
DATE
BOOT
EEPROM

NOR FLASH	OK
SDRAM	OK

The system will also search for the controller application and the local menu...

If present, the menu will appear on the display.

HMI searching	...
DIA	

6.3. DIAGNOSTICS menu

The default DIAGNOSTICS menu of the **M171 Performance Display Graphic** (TM171DGRP) allows you to manage system parameters (BIOS parameters) and the interface (HMI).

The DIAGNOSTICS menu can be displayed in 5 languages: English, Italian, German, Spanish and French.

To change the default language, open BIOS Parameters > Display.

M171 Display Graphic
BIOS parameters
HMI Management

6.3.1. BIOS parameters

Parameter configuration menu. See **CHAPTER 9 Parameters on page 107**.

This menu is depopulated with respect to the parameters table contained in the corresponding chapter and in the **TM171SW (SoMachineHVAC)** device.

A language change example:

BIOS parameters → < **OK** key > Display 1/3 → < **OK** key > Edit Mode < **UP/DOWN** key > select language < **OK** key > < ← key >



See parameter Display/Hmi_Language.

6.3.2. HMI Management

See **6.4. Remote interface on page 84**.

6.4. Remote interface

M171 Display Graphic
Language: 0 ⬆⬇
HMI Management

6.4.1. Language

This section is for setting the language of the remote menu, defined from the **TM171SW (SoMachineHVAC)** User Interface. The number of languages and the order are established by the corresponding application/menu.

See parameter HMI Management/Hmi_Language (see **CHAPTER 9 Parameters on page 107**).

6.4.2. ⬆⬇

To return to the menu of the controller application, move the cursor onto the ⬆⬇ symbol and press the **OK** key.

6.4.3. HMI Management

This page shows the configuration of the remote page.

M171 Display Graphic	
File: HMIREM.KBD	↑↓
Id: 0	☐↑
Com: CAN	
Addr: 124	

From these pages it is possible to “launch” (run) the corresponding menu – if present.

Move the cursor to ↑↓ and press the **OK** key.

To “upload” a remote page use ☐↑

After selecting the desired menu move the cursor to ↑↓ to view the menu.

Upload remote page	
Upload page?	
The process cannot be interrupted	
Cancel	OK

Press **OK** to upload or any other key to cancel:

Upload remote page	
Uploading...	
■ ■ ■ ■ ■ ■ ■ ■ □ □	
80%	

The upload may take up to a minute.

If there are no data to upload, the following screen displays:

Upload remote page	
There are no remote pages on the card.	
Press OK	

CHAPTER 7

M171 Performance Flush user interface

The interface, comprising the front cover of the controller, allows you to perform operations to use the device.

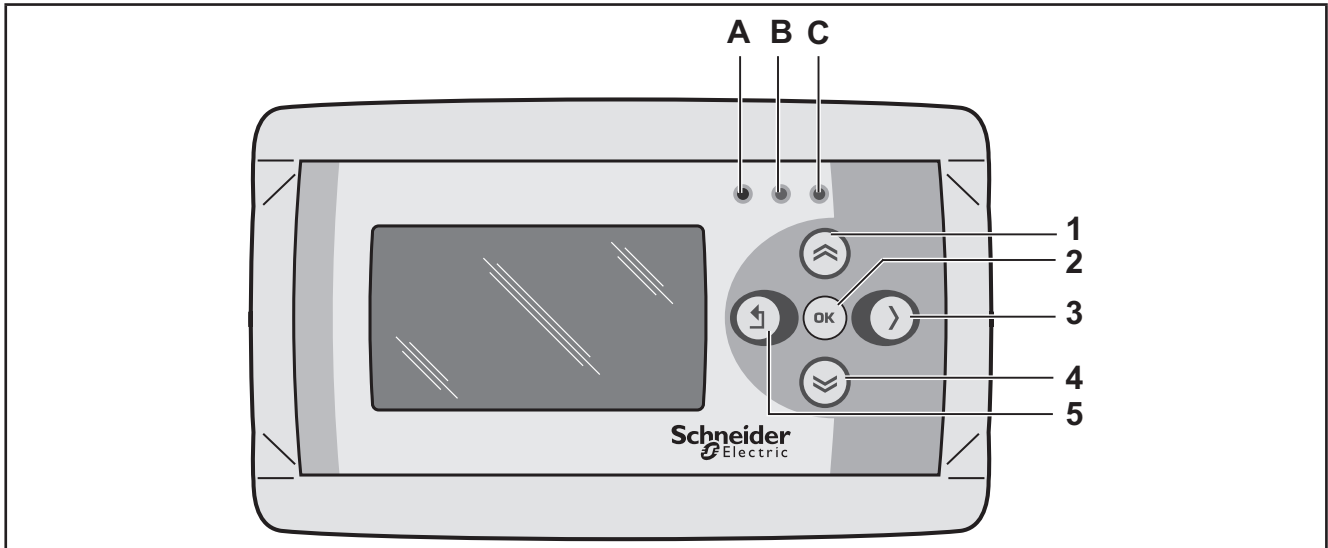

Fig. 58. M171 Performance Flush

The keys can be programmed from the controller application. By default, the device displays a short menu containing the following default settings.

7.1. Keys and LEDs

No.	Key	Press once (press and release)
1	 UP	<ul style="list-style-type: none">• Scroll up• Return to previous page (for example 2/10 ← 3/10)• Increase / modify a value• Go to the next label
2	OK	<ul style="list-style-type: none">• Scroll down• Move to next level/menu (open folder, subfolder, parameter value)• Enter/exit Edit mode• Confirm operation
3	RIGHT >	<ul style="list-style-type: none">• Moves cursor to right in Edit Mode
4	DOWN 	<ul style="list-style-type: none">• Scroll down• Move to the next page (for example 1/10 → 2/10)• Decrease / modify a value• Go to previous label
5	 Exit	<ul style="list-style-type: none">• Exit menu page / go back to previous menu• Move cursor to left in Edit Mode• (press and hold) Exit Edit Mode without saving any changes

The **M171 Performance Flush** is factory-configured with a default DIAGNOSTICS (DIA) menu that appears when the equipment is powered on.

After uploading of a controller application and/or a HMI menu from **TM171SW (SoMachineHVAC)**, the main display consists of the application menu created with **TM171SW (SoMachineHVAC)** Interface.

In which case, to open the DIAGNOSTICS menu proceed as follows:

Key combination		Press and hold for about 3 seconds
4+5	DOWN	Open DIAGNOSTICS menu
	↵ Exit	

The LEDs can be programmed from the controller application.

LEDs	Description
A B C	A, B and C LEDs are programmable via controller application

To return to the controller application menu open the 'HMI Management' page ([7.3.2. HMI management on page 88](#)), select ↵ and press the **OK** key.

See [7.4. Remote interface on page 90](#).

7.2. First power on

When the equipment is powered up for the first time, a few summary pages are displayed showing system status (**SYSTEM INFO**).

SYSTEM INFO
HW
BIOS
DATE
BOOT
EEPROM

NOR FLASH	OK
NAND FLASH	OK
SDRAM	OK
BATRAM	OK
RTC	OK

The system will also search for the controller application and the local menu...
If present, the menu will appear on the display

PLC searching	...
HMI searching	...
CON	loaded

7.3. DIAGNOSTIC menu

The DIAGNOSTICS menu of the **M171 Performance Flush** is used to manage system parameters (BIOS parameters), remote interfaces (HMI) and to display I/O values and clock.

The DIAGNOSTICS menu can be displayed in 5 languages: English, Italian, German, Spanish and French.

To change the language, open BIOS Parameters > Display

M171 Performance Flush
BIOS parameters
HMI Management
Probe values
Date and time

7.3.1. BIOS parameters

For Parameter configuration menu, see **CHAPTER 9 Parameters on page 107**.

This menu is depopulated with respect to the parameters table contained in the corresponding chapter and in the **TM171SW (SoMachineHVAC)** device.

A language change example:

BIOS parameters → < **OK** key > Display 1/3 → < **OK** key > Edit Mode < **UP/DOWN** key > select language < **OK** key > < ← key >



See parameter Display/Hmi_Language.

7.3.2. HMI management

See **7.4. Remote interface on page 90**.

7.3.3. Probe values

Shows input values (read only).

M171 Performance Flush has 3 inputs.

A **TM171PFE03HR** example:

Probes values 1/3
Internal NTC
27.3
°C, °F

Probes values 2/3
External NTC

°C, °F

Probes values 3/3
Humidity sensor
43.38
RH%

For offset programming see **8.1.2. Analog inputs configuration for M171EP14R on page 94**.

7.3.4. Date and time

Shows time (HH : MM : SS) and date (DD / MM / YY) of the internal clock.

Date and time
14 : 45 : 45 20 / 07 / 11
Update

To edit the value press **OK**. Select the value that you want to modify. Press the **OK** key to enter Edit Mode. Use the **UP** and **DOWN** keys to modify value. Confirm with the **OK** key. Select 'Update' and press **OK** to update the clock.

Date and time
16 : 50 : 56 20 / 07 / 11
Update

7.4. Remote interface

M171 Performance Flush	
Language: 0	↑↓
HMI sel: Network	
COM setting	
HMI Management	

7.4.1. Language

This section is for setting the language of the remote menu, defined from the **TM171SW (SoMachineHVAC)** User Interface. The number of languages and the order are established by the corresponding application/menu. See parameter HMI Management/**Hmi_Language**.

7.4.2. ↑↓

To return to the menu of the controller application, move the cursor onto the ↑↓ symbol and press the **OK** key. See **7.4.3. HMI sel on page 90**.

7.4.3. HMI sel

This section is for setting the menu to be shown on the display. By default HMI menus are NOT present (only the DIAGNOSTICS menu is available).

Network: this is the **M171 Performance Flush** 'local' menu (local HMI).

rem1...rem10: menus located on max 10 **M171 Performance** devices connected to the network that can be 'uploaded' to **M171 Performance Flush**.

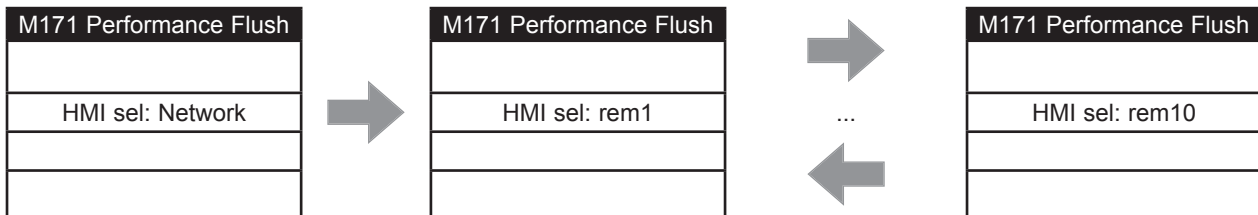

To move from one page to the next press the **UP** and **DOWN** keys. After selecting the desired menu move the cursor onto ↑↓ to view the menu

Launch remote page
Please Wait

If OK the display will show the selected menu (controller application). If the menu is not present, the following screen appears

Warning
Upload failed
Press OK

7.4.4. COM Setting

This **read-only** page shows the configuration of the **M171 Performance Flush** serial ports.

M171 Performance Flush
CAN : 1 . 500000
485s : 1 . 38400.P81
ETH : 010.000.000.100

7.4.5. HMI Management

This page shows the configuration of the 10 remote pages.

M171 Performance Flush 1/10	M171 Performance Flush 1/10	...	M171 Performance Flush 10/10
File: HMIREM.KBD			
Id: 0	Id: 0		Id: 0
Com: CAN	Com: CAN		Com: CAN
Addr: 125	Addr: 000		Addr: 000

From these pages it is possible to 'launch' (run) the corresponding menu – if present
Move the cursor onto $\uparrow\downarrow$ and press the **OK** key.

It will not be possible to launch the local (network) menu from this section.
In the example only one remote page is present.

To 'upload' a remote page use $\square\uparrow$.

After selecting the desired menu move the cursor onto $\uparrow\downarrow$ to view the menu.

Upload remote page
Upload page?
The process cannot be interrupted
Cancel OK

Press **OK** to upload or any other key to cancel

Upload remote page
Uploading...
■■■■■■■■■■□□
80%

The upload may take up to a minute.

If there are no data to upload, the following screen displays

Warning
There are no remote pages on the card
Press OK

CHAPTER 8

Physical I/O and ports configuration

From time to time, new input modules, output modules or other devices are made available that are not documented in the following information. For information on new devices, contact your local Schneider Electric representative.

NOTICE

INOPERABLE EQUIPMENT

Update the controller firmware to the latest version every time you install a newly released Input/Output expansion module or other device to this equipment.

Failure to follow these instructions can result in equipment damage.

NOTE: For more information on how to update the controller firmware, contact your local Schneider Electric representative.

	M171 Performance	M171 Performance Flush
Analog inputs	Configurable by parameter (see 8.1.1. Analog inputs configuration for M171 Performance on page 93)	Configurable by parameter (see 8.1.2. Analog inputs configuration for M171EP14R on page 94)
Analog outputs	Configurable by parameter (see "8.2. Analog outputs configuration for M171 Performance")	-
Digital inputs	Configurable by parameter (see 8.3. Digital inputs configuration for M171 Performance on page 97)	-
Digital outputs	Configurable by parameter (see 8.4. Digital outputs configuration for M171 Performance on page 97)	-
Serials	Configurable by parameter (see 9.1.1. TM171PDM27• / TM171PBM27R / TM171EP27R parameters on page 108) or dip-switch (see on page 97)	Configurable by parameter (see 9.1.2. M171EP14R parameters on page 119)

Applying incorrect current or voltage levels on analog inputs and outputs could damage the electronic circuitry. Further, connecting a current input device to an analog input configure for voltage, and vice-versa, will likewise damage the electronic circuitry.

NOTICE

INOPERABLE EQUIPMENT

- Do not apply voltages above 11 Vdc to the analog inputs of the controller or Input/Output expansion module when analog input is configured as 0-10V input.
- Do not apply current above 30 mA to the analog inputs of the controller or Input/Output expansion module when analog input is configured as 0-20 mA or 4-20 mA input.
- Do not mismatch applied signal with analog input configuration.

Failure to follow these instructions can result in equipment damage.

8.1. Analog inputs

M171 Performance and M171 Performance Flush have analog inputs.

8.1.1. Analog inputs configuration for M171 Performance

There are a total of 6 analog inputs, referred to below as AI1...AI6.

Using the parameters, a physical resource (probe, digital input, voltage/current signal) can be configured for each type of input:

- 2 inputs can be configured as temperature probes (NTC type probe) or as digital inputs.
- 4 inputs (AI3...AI6) can be configured as temperature probes (NTC or Pt1000), as digital inputs or as a current/voltage input (4-20mA signal/ 0-10V, 0-5V ratiometric).

Inputs can be configured as specified in the table below.

Parameter	Description	Value								
		0	1	2	3	4	5	6	7	8
Cfg_AI1	Type of analog input AI1	NTC probe (NK103)	Probe configured as voltage-free digital input	NTC probe (103AT)	-	-	-	-	-	-
Cfg_AI2	Type of analog input AI2	NTC probe (NK103)	Probe configured as voltage-free digital input	NTC probe (103AT)	-	-	-	-	-	-
Cfg_AI3	Type of analog input AI3	NTC probe (NK103)	Probe configured as voltage-free digital input	NTC probe (103AT)	4-20 mA (1)	0-10 V (1)	0-5 V Ratiometric (1)	PT1000	hΩ (NTC) (2)	daΩ (PT1000) (3)
Cfg_AI4	Type of analog input AI4	NTC probe (NK103)	Probe configured as voltage-free digital input	NTC probe (103AT)	4-20 mA	0-10 V	0-5 V Ratiometric	PT1000	hΩ (NTC)	daΩ (PT1000)
Cfg_AI5	Type of analog input AI5	NTC probe (NK103)	Probe configured as voltage-free digital input	NTC probe (103AT)	4-20 mA	0-10 V	0-5 V Ratiometric	PT1000	hΩ (NTC)	daΩ (PT1000)
Cfg_AI6	Type of analog input AI6	NTC probe (NK103)	Probe configured as voltage-free digital input	NTC probe (103AT)	4-20 mA	0-10 V	0-5 V Ratiometric	PT1000	hΩ (NTC)	daΩ (PT1000)

(1) 4-20 mA / 0-10V / 0-5 V ratiometric

Minimum full scale AIx

- for current probe, value = 4 mA,
- for 0-10 V voltage probe, value = 0 V,
- for ratiometric probe (0÷5V), value = 10% (corresponding to 0.5 V)

Maximum full scale AIx

- for current probe, value = 20 mA,
- for 0-10V voltage probe, value = 10 V,
- for ratiometric probe (0÷5 V), value = 90% (corresponding to 4.5 V)

(2) Cfg_AIx = 7 Resistance value read, expressed in hΩ, for a resistance applied to the input using the controller in NTC configuration, i.e. **creating a divider with pull-up resistance of 10 kΩ.**

(3) Cfg_AIx = 8 Resistance value read, expressed in daΩ, for a resistance applied to the input using the controller in PT1000 configuration, i.e. **creating a divider with pull-up resistance of 2 kΩ.**

Note: Typically used with potentiometer at input.

The resistance range for the hΩ (NTC) configuration is up to 150 K, and up to 30 K for the daΩ (PT1000) configuration.

Parameter	Range	Description
FullScaleMin_AI3	-9999...+9999	Analog input AI3 start of scale value
FullScaleMax_AI3	-9999...+9999	Analog input AI3 full scale value
FullScaleMin_AI4	-9999...+9999	Analog input AI4 start of scale value
FullScaleMax_AI4	-9999...+9999	Analog input AI4 full scale value
FullScaleMin_AI5	-9999...+9999	Analog input AI5 start of scale value
FullScaleMax_AI5	-9999...+9999	Analog input AI5 full scale value
FullScaleMin_AI6	-9999...+9999	Analog input AI6 start of scale value
FullScaleMax_AI6	-9999...+9999	Analog input AI6 full scale value

The values read by analog inputs can be configured via the following parameters:

Parameter	Description	Measurement Unit	Range
Calibration_AI1	Analog input AI1 differential	°C/10 or °F/10	-180 ... 180
Calibration_AI2	Analog input AI2 differential	°C/10 or °F/10	-180 ... 180
Calibration_AI3	Analog input AI3 differential	-	-1000 ... 1000
Calibration_AI4	Analog input AI4 differential	-	-1000 ... 1000
Calibration_AI5	Analog input AI5 differential	-	-1000 ... 1000
Calibration_AI6	Analog input AI6 differential	-	-1000 ... 1000

8.1.2. Analog inputs configuration for M171EP14R

There are a total of 4 analog inputs, referred to below as AI1...AI4.

Using the parameters, a physical resource (probe, digital input, voltage/current signal) can be "physically" configured for each type of input

The inputs are configurable in pairs AI1, AI2 and AI3, AI4

Inputs can be "physically" configured as specified in the table below.

Par	Description	Value										
		0	1	2	3	4	5	6	7	8	9	10
Cfg_AIx x=1...4	Type of analog input AIx	NTC probe (NK103)	DI (1)	NTC probe (103AT)	4-20 mA (2)	0-10 V (2)	0-5 V Ratiometric (2)	PT1000	hΩ (NTC) (3)	daΩ (PT1000) (4)	PTC (KTY81)	0-5 V

(1) DI Input configured as voltage-free digital input

(2) **4-20 mA / 0-10 V / 0-5 V ratiometric**

Minimum full scale AIx

- for current probe, value = 4 mA,
- for 0-10V voltage probe, value = 0 V,
- for ratiometric probe (0÷5 V), value = 10% (corresponding to 0.5 V)

Maximum full scale AIx

- for current probe, value = 20 mA,
- for 0-10 V voltage probe, value = 10 V,
- for ratiometric probe (0÷5V), value = 90% (corresponding to 4.5 V)

(3) Cfg_AIx = 7 Resistance value read, expressed in hΩ, for a resistance applied to the input using the controller in NTC configuration, i.e. **creating a divider with pull-up resistance of 10 kΩ.**

(4) Cfg_AIx = 8 Resistance value read, expressed in daΩ, for a resistance applied to the input using the controller in PT1000 configuration, i.e. **creating a divider with pull-up resistance of 2 kΩ.**

Note: Typically used with potentiometer at input.

The resistance range for the hΩ (NTC) configuration is up to 150 K, and up to 30 K for the daΩ(PT1000) configuration.

Allowed configurations for analog inputs

The pairs (AI1, AI2) and (AI3, AI4) shall be configured as specified in the table below.

Cells compiled show correct combinations. Empty cells indicate incorrect combinations.
Applying incorrect configuration will produce 0x8003 error on probes range configuration

		Cfg_AI1 / Cfg_AI3										
		0	1	2	3	4	5	6	7	8	9	10
Cfg_AI2 / Cfg_AI4	0	NTC probe (NK103)	DI	NTC probe (103AT)	-	-	-	-	hΩ (NTC)	-	-	-
	1	NTC probe (NK103)	DI	NTC probe (103AT)	-	-	-	-	hΩ (NTC)	-	-	-
	2	NTC probe (NK103)	DI	NTC probe (103AT)	-	-	-	-	hΩ (NTC)	-	-	-
	3	-	-	-	4-20 mA	-	-	-	-	-	-	-
	4	-	-	-	-	0-10 V	-	-	-	-	-	-
	5	-	-	-	-	-	0-5 V Ratiometric	-	-	(PT1000)	-	0-5 V
	6	-	-	-	-	-	-	PT1000	-	daΩ (PT1000)	-	-
	7	NTC probe (NK103)	DI	NTC probe (103AT)	-	-	-	-	hΩ (NTC)	-	PTC (KTY81)	-
	8	-	-	-	-	-	-	PT1000	-	daΩ (PT1000)	PTC (KTY81)	-
	9	-	-	-	-	-	-	PT1000	-	daΩ (PT1000)	PTC (KTY81)	-
	10	-	-	-	-	-	0-5 V Ratiometric	-	-	-	-	0-5 V

8.1.3. Analog inputs configuration for M171 Performance Flush

Inputs can be configured as specified in the table below.

Parameter	Description	Values					
		0	1	2	3	4	5
Cfg_AI1	Type of input analog AI1	NTC probe (NK103)	Probe configured as voltage-free digital input	NTC probe (103AT-2)	-	-	-
Cfg_AI2	Type of input analog AI2	NTC probe (NK103)	Probe configured as voltage-free digital input	NTC probe (103AT-2)	-	-	-
Cfg_AI3	Type of input analog AI3	-	-	-	4-20 mA	0-10 V	0-5 V

Parameter	Range	Description
FullScaleMin_AI3	-9999...+9999	Analog input AI3 start of scale value
FullScaleMax_AI3	-9999...+9999	Analog input AI3 full scale value

The temperature and humidity measurement, as well as the corresponding precisions and tolerances, refer to the application point of the probes inside the equipment.

If these same measurements are to be referred to air conditions outside of the equipment, for example ambient measurements, account must be taken of offset (differential) parameters that depend on the installation and usage conditions of the equipment itself. The differentials for example **Calibration** parameters that can be set are:

Parameter	Description	Unit of measure	Range
Calibration_AI1	Analog input AI1 differential	°C/10 or °F/10	-180 ... 180
Calibration_AI2	Analog input AI2 differential	°C/10 or °F/10	-180 ... 180
Calibration_AI3	Analog input AI3 differential	-	-1000 ... 1000
Calibration_AI4	Analog input AI4 differential	-	-1000 ... 1000

For on-board (built-in) sensors, **Compensation** parameters are also available

Parameter	Description	Unit of measure	Range
Compensation_AI1	Internal compensation AI1 difference between external air temperature and measurement read by NTC sensor AI1	°C/10 or °F/10	-1000 ... 1000
Compensation_AI4	Internal compensation AI4 difference between external temperature and T measurement read by RH sensor AI4 (this temperature is used to calculate the relative humidity based on psychrometric charts)	°C/10 or °F/10	-1000 ... 1000

Default values for these offsets assume a typical installation with wall mounted backplate in a non-ventilated environment and with the display backlighting mainly OFF. In these conditions the following calibration values are obtained:

Compensation_AI1 = -12.0 °C (10.4 °F)

Compensation_AI4 = -10.5 °C (13.1 °F)

If the usage conditions require the backlight to be mainly ON, the values must be modified as follows:

Compensation_AI1 = -15.0 °C (5.0 °F)

Compensation_AI4 = -13.0 °C (8.6 °F)

NOTE: For other mounting conditions carry out **calibration** during installation, checking the temperature and relative humidity differences between the external air and the internal probes and if necessary correcting the parameters **Compensation_AI1** / **Compensation_AI4**.

In any case it is possible to achieve a precision of ± 1°C on the temperature measurement and ± 3%RH on the relative humidity measurement.

8.2. Analog outputs configuration for M171 Performance

See **CHAPTER 3 Electrical connections on page 23** for the number and type of analog outputs used and for information on the symbols used on labels supplied with the controller.

There are 5 analog outputs with the following characteristics:

Configuration of analog output

AO1/AO5	AO2	AO3	AO4
Current/voltage output AO1 and AO5 are configured in pairs.	Current/voltage output	Current/voltage output	Current/voltage output
Sub-mode configuration AO5 Only if AO1/AO5 have not been configured as voltage outputs (value ≠2)	-	-	-

Outputs AO1, AO2, AO3, AO4, AO5 are configurable as:

- 0 = 4-20mA current analog output
- 1 = output configured as 0...20mA switch (ON= max 20mA, OFF=0mA) for piloting switch loads such as ON/OFF.
- 2 = 0-10V voltage analog output.

Outputs AO4, AO5 can be configured as Open Collector output. Set:

- **Cfg_AO4** = 1 (ON/OFF type switching)
- **Cfg_AO1_AO5** = 0 or 1 (pair of outputs configured as current outputs)
- **SubCfg_AO5** = 1 (ON/OFF type switching)
- Analog value piloted for both outputs = 0.

For developers using TM171SW (SoMachineHVAC): see the sysAOasOC function (target block) in the **TM171SW (SoMachineHVAC)** Application Library

8.3. Digital inputs configuration for M171 Performance

There are 8 digital inputs, identified below as DI1...DI8. They are grouped as:

- DI1...DI4
- DI5...DI8

Each one has its own common contact.

Digital inputs can be used as pulse counters.

The length of the pulse (positive or negative) must be greater than 12ms.

There is also a fast, voltage-free digital input that also works as a pulse counter:

- It reads the number of times the contact applied to the input closes.
- It reads frequencies from 0.1 Hz to 1 kHz.

8.4. Digital outputs configuration for M171 Performance

See **CHAPTER 3 Electrical connections on page 23** for the number and capacity of relays and/or SSR depending on the reference, and for information on the symbols used on labels supplied with the controller.

- There are 7 high voltage outputs (relays) identified as DO1...DO7.
- In references **TM171PDM27S** there are 5 high voltage outputs (relays) identified as DO1...DO3, DO6, DO7 whereas there are 2 SSR outputs identified as DO3...DO4.

8.5. Ports configuration for M171 Performance using DipSwitch

Dipswitches are used for the configuration of serial ports, which can be On-Board (OB) or available via Communication Module **TM171A●●●●** modules (PI).

4-position lateral DipSwitch

There is a 4-position lateral DipSwitch (microswitch) in all **TM171PDM27●**, **TM171PBM27R** and **TM171EP●●R** expansion references.

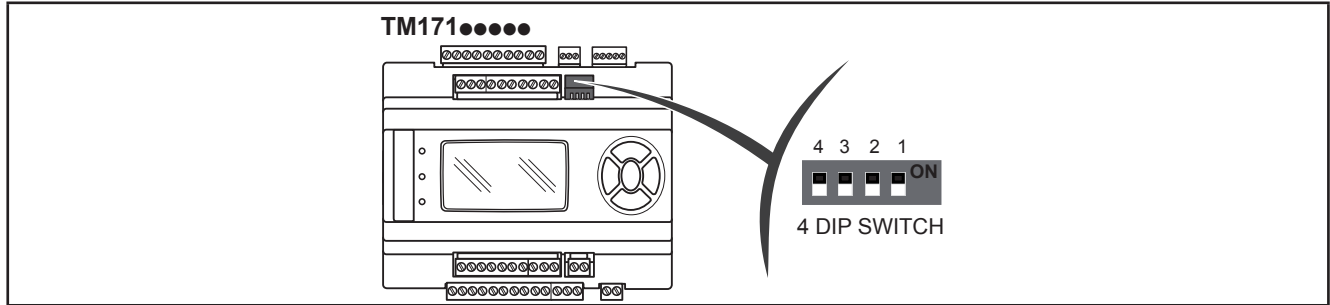

6 and 10-position DipSwitch

Under the front panel, **TM171PBM27R** and **TM171EP●●R** expansion references have:

- A 6-position DipSwitch (microswitch) (SW2)
- A 10-position DipSwitch (microswitch) (SW1)

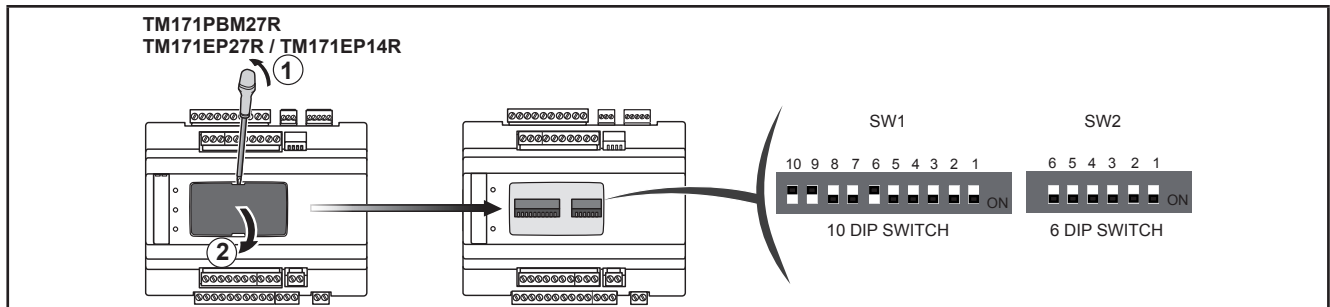

Remove the front panel with a fingernail, or the tip of a slot head screwdriver. Configure as necessary then replace the front panel by pressing lightly back into place.

4-position DipSwitch compared to 6 and 10-position DipSwitch

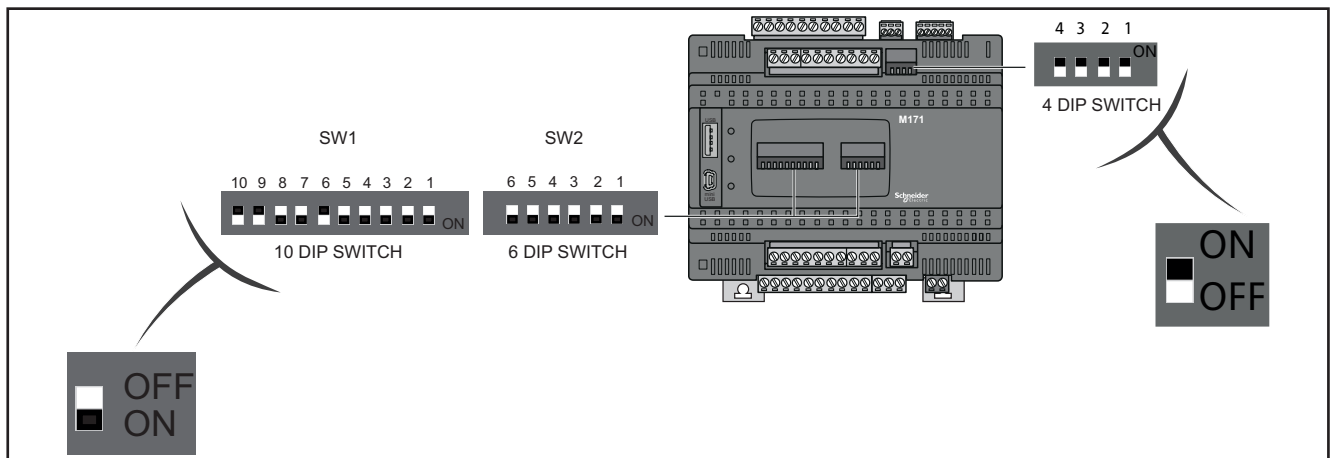

NOTE. OFF=0 / ON=1

8.5.1. TM171PDM27• DipSwitch

4-position lateral DipSwitch

Used for serial addressing only.

The address is given by the sum of the value of a parameter (1) plus the value defined by the dipswitch (16 addresses).

Serial Addressing Default=0	Dip value	4-position dip			
		Dip4	3	2	1
<div style="text-align: center;"> <p>4 3 2 1</p>  <p>LOW Address</p> </div>	0	0	0	0	0
	1	0	0	0	1
	2	0	0	1	0
	3	0	0	1	1

	15	1	1	1	1

Address			
Parameter (1)	Default Parameter	+	LOW address Default=0
Addr_RS485_OB	1		+
Addr_CAN_OB	1		
Addr_RS485_PI	1		
Addr_CAN_PI	1		
Addr_RS232_PI	1		
Ip_4_ETH_PI	100		

8.5.2. TM171PBM27R DipSwitch

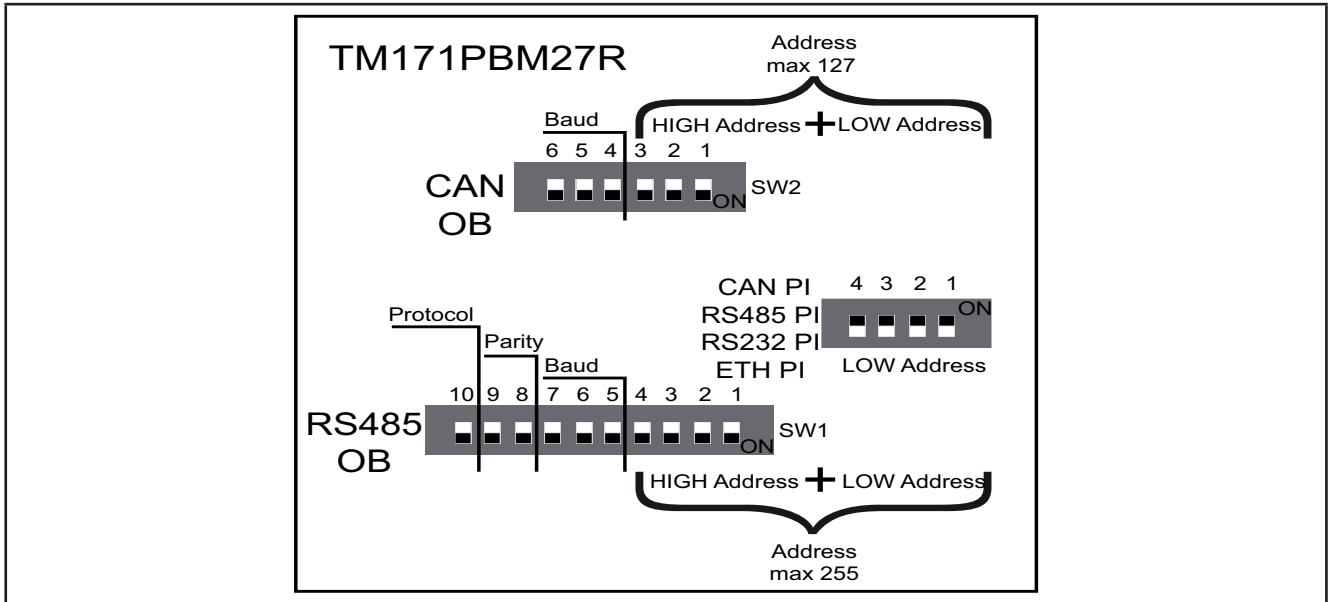

Fig. 59. TM171PBM27R Dipswitch

Serial addressing

4-position DipSwitch

Used for the serial addressing of the plug-in port (PI) only.

In the serial addressing of On-Board (OB) serial ports, the 4-position dip is not used for TM171PBM27R.

The address is given by the sum of the value of a parameter (1) plus the value defined by the dipswitch (16 addresses).

Serial Addressing Default=0	Dip value	4-position dip			
		Dip4	3	2	1
<p>LOW Address</p>	0	0	0	0	0
	1	0	0	0	1
	2	0	0	1	0
	3	0	0	1	1

	15	1	1	1	1

Address			
Parameter (1)	Default Parameter	+	LOW address Default=0
Addr_RS485_PI	1		
Addr_CAN_PI	1		
Addr_RS232_PI	1		
Ip_4_ETH_PI	100		

Baud

6-position TM171PBM27R DipSwitch

The actual CAN Baud rate comprises the sum of parameter **Baud_CAN_OB** plus the composite value of the 3-position dip-switches (8 values).

CAN baud selection OB Default = 500 baud	Dip value	Dip6	5	4	3	2	1
	0	0	0	0	-	-	-

Actual CAN Baud Value Default = 500 baud		Parameter Baud_CAN_OB		CAN baud selection Default = 0
2=500	=	Parameter Baud_CAN_OB	+	
3=250				
4=125				
5=125				
6=50				
default example		2	+	0

CAN OB serial addressing

6-position dipswitch + 4-position dipswitch

The addressing comprises the sum of parameter **Addr_CAN_OB** plus the composite value of the 6 and 4-position dipswitches (127 addresses).

CAN OB serial addressing Default = 1	Dip value	6-position dip HIGH address						4-position dip LOW address			
		Dip6	5	4	3	2	1	Dip4	3	2	1
	0	-	-	-	0	0	0	0	0	0	0
	1	-	-	-	0	0	0	0	0	0	1
	2	-	-	-	0	0	0	0	0	1	0
	3	-	-	-	0	0	0	0	0	1	1

	126	-	-	-	1	1	1	1	1	1	0

Address		
Parameter		HIGH+LOW address - Default = 0
Addr_CAN_OB	+	
1	+	0

RS485 OB serial configuration

10-position dipswitch

		Dip value	Dip10	9	8	7	6	5	4	3	2	1	
Protocol selection RS485 OB Default = 1		0	0	-	-	-	-	-	-	-	-	-	
		1	1	-	-	-	-	-	-	-	-	-	-
Parity selection RS485 OB Default = EVEN		0	-	0	0	-	-	-	-	-	-	-	
		1	-	0	1	-	-	-	-	-	-	-	-
		2	-	1	0	-	-	-	-	-	-	-	-
Baud selection RS485 OB Default = 38400 baud		0	-	-	-	0	0	0	-	-	-	-	
		1	-	-	-	0	0	1	-	-	-	-	
		2	-	-	-	0	1	0	-	-	-	-	-
		3	-	-	-	0	1	1	-	-	-	-	-
		4	-	-	-	1	0	0	-	-	-	-	-
		5	-	-	-	1	0	1	-	-	-	-	-

Parameter	Default Parameter		LOW address Default = 0
Proto_RS485_OB	2=Reserved	+	
	3= Modbus RTU		
Parity_RS485_OB	0= NULL	+	
	1= ODD		
	2= EVEN		
Baud_RS485_OB	0=9600	+	
	1=19200		
	2=38400		
	3=57600		
	4=76800		
	5=115200		

RS485 OB serial addressing

10-position dipswitch + 4-position dipswitch

The address is given by the sum of the value of the two 6 and 4-position dipswitches (255 addresses).

Serial addressing RS485 OB Default = 1	Dip value	10-position dip HIGH address					4-position dip LOW address			
		Dip10...5	4	3	2	1	Dip4	3	2	1
	0	-	0	0	0	0	0	0	0	0
	1	-	0	0	0	0	0	0	0	1
	2	-	0	0	0	0	0	0	1	0
	3	-	0	0	0	0	0	0	1	1

254	-	1	1	1	1	1	1	1	0	

Address		
Parameter		LOW address Default = 0
Addr_RS485_OB	+	
1	+	0

NOTE: Any other combination of the dipswitches not listed here is not permitted.

To summarize, in the case of **TM171PBM27R**, the default configuration for all dipswitches is as follows:

TM171PBM27R DipSwitch default configuration

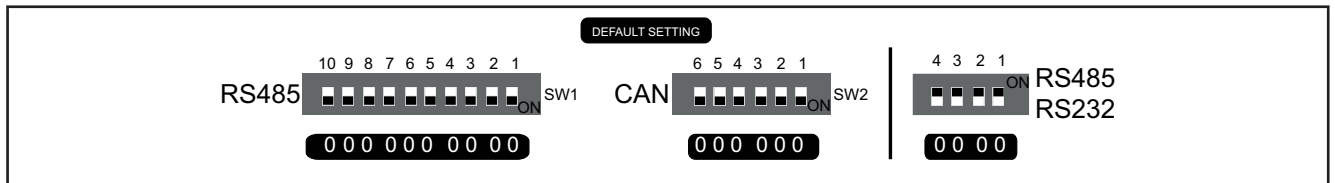

Fig. 60. Default setting

RS232 OB configuration and serial addressing

6 and 10-position dipswitches are not used.

See [CHAPTER 9 Parameters on page 107](#).

8.5.3. TM171EP27R expansion DipSwitch

TM171EP27R expansion serials are configured by configuring dipswitches, without using the "internal" parameters visible in the **CHAPTER 9 Parameters on page 107**.

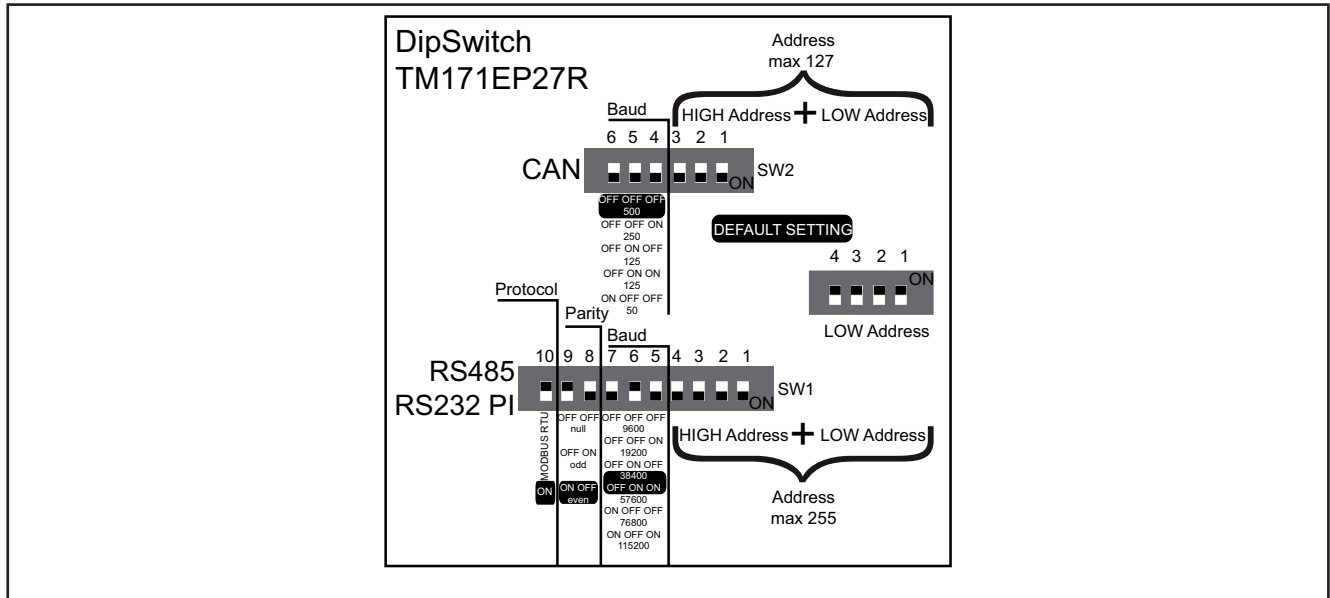

Fig. 61. Dipswitch TM171EP27R

Baud

6-position TM171EP27R dipswitch

CAN baud selection OB and PI Default = 500 baud	Baud	Dip value	Dip6	5	4	3	2	1
	500	0	0	0	0	-	-	-
	250	1	0	0	1	-	-	-
	125	2	0	1	0	-	-	-
	125	3	0	1	1	-	-	-
	50	4	1	0	0	-	-	-

CAN OB and PI serial addressing

6-position dipswitch + 4-position TM171EP27R dipswitch

The address is given by the value of the 6 and 4-position dipswitches (127 addresses).

CAN serial addressing OB and PI Default = 1	Address	Dip value	6-position dip HIGH address						4-position dip LOW address			
			Dip6	5	4	3	2	1	Dip4	3	2	1
	1	0	-	-	-	0	0	0	0	0	0	0
	2	1	-	-	-	0	0	0	0	0	0	1
	3	2	-	-	-	0	0	0	0	0	1	0
	4	3	-	-	-	0	0	0	0	0	1	1

	127	126	-	-	-	1	1	1	1	1	1	0

RS232 PI and RS485 OB serial configuration

10-position dipswitch

		Protocol	Dip value	Dip10	9	8	7	6	5	4	3	2	1	
Protocol selection RS232 PI / RS485 OB Default = 1		Reserved for Schneider Electric use	0	0	-	-	-	-	-	-	-	-	-	
		ModBus RTU	1	1	-	-	-	-	-	-	-	-	-	-
Parity selection RS232 PI / RS485 OB Default = EVEN		Null	0	-	0	0	-	-	-	-	-	-	-	
		Odd	1	-	0	1	-	-	-	-	-	-	-	-
		Even Even	2	-	1	0	-	-	-	-	-	-	-	-
Baud selection RS232 PI / RS485 OB Default = 38400 baud		9600	0	-	-	-	0	0	0	-	-	-	-	
		19200	1	-	-	-	0	0	1	-	-	-	-	-
		38400	2	-	-	-	0	1	0	-	-	-	-	-
		57600	3	-	-	-	0	1	1	-	-	-	-	-
		76800	4	-	-	-	1	0	0	-	-	-	-	-
		115200	5	-	-	-	1	0	1	-	-	-	-	-

RS485 OB and PI serial addressing

10-position dipswitch + 4-position dipswitch

The address is given by the sum of the value of the two 6 and 4-position dipswitches (255 addresses).

CAN serial addressing OB and PI Default = 1	Address	Dip value	10-position dip HIGH address				4-position dip LOW address						
			Dip10...5	4	3	2	1	Dip4	3	2	1		
	1	0	-	0	0	0	0	0	0	0	0	0	0
	2	1	-	0	0	0	0	0	0	0	0	0	1
	3	2	-	0	0	0	0	0	0	0	0	1	0
	4	3	-	0	0	0	0	0	0	0	0	1	1

	255	254	-	1	1	1	1	1	1	1	1	1	0

NOTE: Any other combination of the dipswitches not listed here is not permitted.

To summarize, in the case of **TM171EP27R**, the default configuration for the dipswitches is as follows:

TM171EP27R DipSwitch default configuration

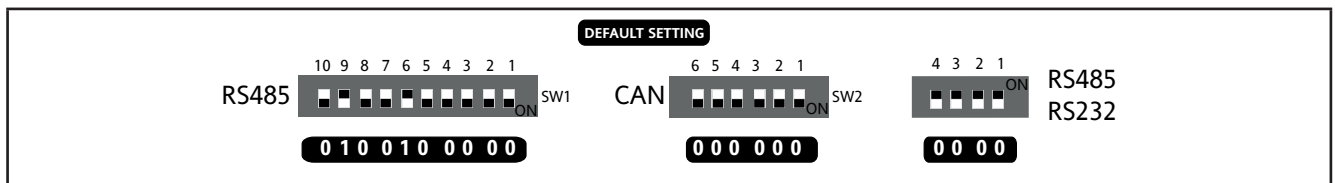

Fig. 62. Default setting

8.5.4. TM171EP14R expansion DipSwitch

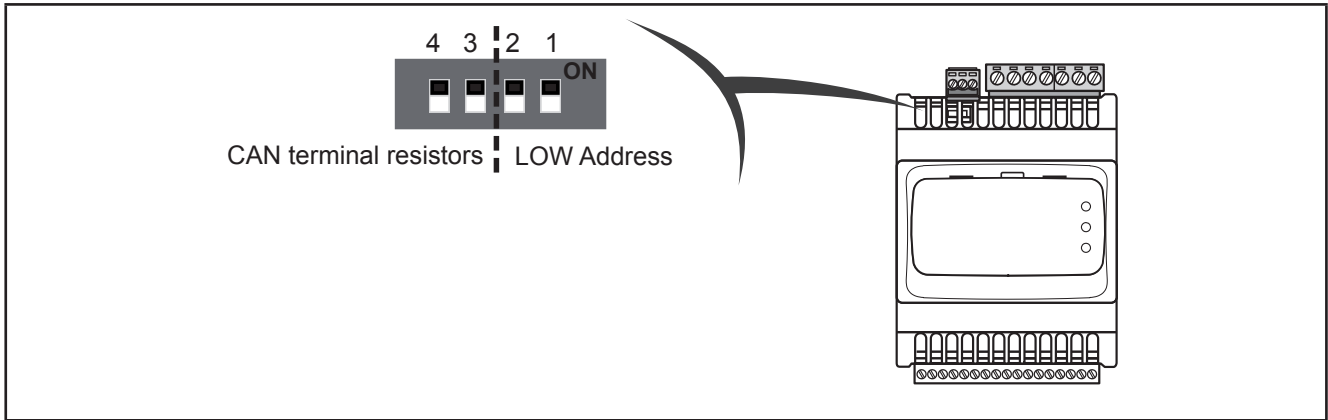

Fig. 63. 4-position lateral DipSwitch

Used for:

- serial addressing (dip 1 and 2)
- line termination (dip 3 and 4)

Serial Addressing	Address = DipValue+1	Dip value	4-position dip			
			Dip4	3	2	1
	1	0	-	-	0	0
	2	1	-	-	0	1
	3	2	-	-	1	0
	4	3	-	-	1	1
	Dip value (Address)	Dip value (Address)	Dip4	3	2	1
	120 Ω termination	120 Ω termination	1	1	-	-

CAN OB serial addressing

The addressing comprises the sum of parameter **Addr_CAN_OB** plus the composite value of the 4-position dipswitches (only dip 1 and 2).

Actual CAN Address Default = 1		Parameter Addr_CAN_OB Default = 1		CAN address selection Default = 0
1	=	Parameter Baud_CAN_OB	+	
2				
...				
...				
127 max				
default example		1	+	0

Baud

Baud rate is set by **Baud_CAN_OB** parameter

Line Termination resistors

Dip4 and Dip3 both = 1 connects L/H CAN lines to 120 Ω termination

CHAPTER 9

Parameters

User-parameterization renders the **Modicon M171P** configurable.

Parameters can be changed using:

- Keys on the **TM171PDM27** / **M171 Performance Flush** front panel or remote **M171 Performance Display Graphic** (TM171DGRP) panel.
- PC and **TM171SW (SoMachineHVAC)** software.

The following sections provide a detailed analysis of each parameter, divided into categories (folders).

For **M171 Performance**, the parameter table shows the configuration parameters for the controller saved in the non-volatile memory.

For **M171 Performance Flush**, the parameter table contains the device configuration parameters available in **TM171SW (SoMachineHVAC)** Device and in the DIAGNOSTICS (DIA) / BIOS Parameters menu.

Modbus commands available and data areas

The following commands are implemented:

Modbus command	Description of command
3 (3 hex)	Read multiple registers on Client side
16 (10 hex)	Write multiple registers on Client side
43 (2B hex)	Read device ID: Manufacturer ID Model ID Version ID

9.1. M171 Performance parameter table

This table presents the column headers of the parameter table that follows.

Column	Description
LABEL	Indicates the label used to display the parameters in the menu of the controller.
PAR. VALUE ADDRESS	Indicates the address of the modbus register containing the resource to be accessed.
DATA SIZE	Indicates the size of the data in bits.
CPL	Indicates the register value conversion. To carry out the conversion, proceed as follows: <ul style="list-style-type: none">• If the value in the register is between 0 and 32767, the result is the value itself (zero and positive values)• If the value in the register is between 32768 and 65535, the result is the value of the register minus 65536 (negative values)• When the field indicates "-1", the value read by the register requires conversion, because the value represents a number with a sign.
RESET	Indicates whether the controller MUST be rebooted after the parameter has been modified. <ul style="list-style-type: none">• Y = YES the controller MUST be rebooted to modify the parameter.• Empty " " = NO the controller does not need to be rebooted to modify the parameter
RANGE	Describes the interval of values that can be assigned to the parameter. It can be correlated with other equipment parameters (indicated in the parameter label).
DEFAULT	Indicates the factory setting for the reference.
U.M.	Indicates the unit of measurement for values converted according to the rules indicated in the CPL column The unit of measurement shown is for example purposes only, as it may change depending on the application (for example parameters with a U.M. in °C/bar could also have %RH)

9.1.1. TM171PDM27• / TM171PBM27R / TM171EP27R parameters

LABEL	PAR. VALUE ADDRESS	DATA SIZE	CPL	RESET	DESCRIPTION	RANGE	DEFAULT	U.M.
ACKNOWLEDGEMENT folder								
Par_TAB	15716	WORD	-	Y	Map code Note: read/write parameter	0 ... 65535	0	num
Par_POLI	15717	WORD	-	Y	Model Code Note: read/write parameter	0 ... 65535	2049	num
Par_PARMOD	15719	BOOL	-	-	Parameter modified Flag indicating change to default settings. • 0= map not modified. • 1= at least one parameter has been modified with respect to the original configuration.	0 ... 1	0	num
AI CALIBRATION folder								
Gain_Ntc_AI1	15616	WORD	-	-	Ai1 NTC calibration gain	0 ... 65535	32768	num
Gain_Ntc_AI2	15617	WORD	-	-	Ai2 NTC calibration gain	0 ... 65535	32768	num
Gain_Ntc_AI3	15618	WORD	-	-	Ai3 NTC calibration gain	0 ... 65535	32768	num
Gain_PT1000_AI3	15619	WORD	-	-	Ai3 PT1000 calibration gain	0 ... 65535	32768	num
Gain_5V_AI3	15620	WORD	-	-	Ai3 0-5V calibration gain	0 ... 65535	32768	num
Gain_10V_AI3	15621	WORD	-	-	Ai3 0-10V calibration gain	0 ... 65535	32768	num
Gain_mA_AI3	15622	WORD	-	-	Ai3 4-20mA calibration gain	0 ... 65535	32768	num
Gain_Ntc_AI4	15623	WORD	-	-	Ai4 NTC calibration gain	0 ... 65535	32768	num
Gain_PT1000_AI4	15624	WORD	-	-	Ai4 PT1000 calibration gain	0 ... 65535	32768	num
Gain_5V_AI4	15625	WORD	-	-	Ai4 0-5V calibration gain	0 ... 65535	32768	num
Gain_10V_AI4	15626	WORD	-	-	Ai4 0-10V calibration gain	0 ... 65535	32768	num
Gain_mA_AI4	15627	WORD	-	-	Ai4 4-20mA calibration gain	0 ... 65535	32768	num
Gain_Ntc_AI5	15628	WORD	-	-	Ai5 NTC calibration gain	0 ... 65535	32768	num
Gain_PT1000_AI5	15629	WORD	-	-	Ai5 PT1000 calibration gain	0 ... 65535	32768	num
Gain_5V_AI5	15630	WORD	-	-	Ai5 0-5V calibration gain	0 ... 65535	32768	num
Gain_10V_AI5	15631	WORD	-	-	Ai5 0-10V calibration gain	0 ... 65535	32768	num
Gain_mA_AI5	15632	WORD	-	-	Ai5 4-20mA calibration gain	0 ... 65535	32768	num
Gain_Ntc_AI6	15633	WORD	-	-	Ai6 NTC calibration gain	0 ... 65535	32768	num
Gain_PT1000_AI6	15634	WORD	-	-	Ai6 PT1000 calibration gain	0 ... 65535	32768	num
Gain_5V_AI6	15635	WORD	-	-	Ai6 0-5V calibration gain	0 ... 65535	32768	num
Gain_10V_AI6	15636	WORD	-	-	Ai6 0-10V calibration gain	0 ... 65535	32768	num
Gain_mA_AI6	15637	WORD	-	-	Ai6 0-10mA calibration gain	0 ... 65535	32768	num
Offs_Ntc_AI1	15650	WORD	-1	-	Ai1 NTC calibration offset	-32768 ... 32767	0	num
Offs_Ntc_AI2	15651	WORD	-1	-	Ai2 NTC calibration offset	-32768 ... 32767	0	num
Offs_Ntc_AI3	15652	WORD	-1	-	Ai3 NTC calibration offset	-32768 ... 32767	0	num
Offs_PT1000_AI3	15653	WORD	-1	-	Ai3 PT1000 calibration offset	-32768 ... 32767	0	num

LABEL	PAR. VALUE ADDRESS	DATA SIZE	CPL	RESET	DESCRIPTION	RANGE	DEFAULT	U.M.
Offs_5V_AI3	15654	WORD	-1	-	Ai3 0-5V calibration offset	-32768 ... 32767	0	num
Offs_10V_AI3	15655	WORD	-1	-	Ai3 0-10V calibration offset	-32768 ... 32767	0	num
Offs_mA_AI3	15656	WORD	-1	-	Ai3 4-20mA calibration offset	-32768 ... 32767	0	num
Offs_Ntc_AI4	15657	WORD	-1	-	Ai4 NTC calibration offset	-32768 ... 32767	0	num
Offs_PT1000_AI4	15658	WORD	-1	-	Ai4 PT1000 calibration offset	-32768 ... 32767	0	num
Offs_5V_AI4	15659	WORD	-1	-	Ai4 0-5V calibration offset	-32768 ... 32767	0	num
Offs_10V_AI4	15660	WORD	-1	-	Ai4 0-10V calibration offset	-32768 ... 32767	0	num
Offs_mA_AI4	15661	WORD	-1	-	Ai4 4-20mA calibration offset	-32768 ... 32767	0	num
Offs_Ntc_AI5	15662	WORD	-1	-	Ai5 NTC calibration offset	-32768 ... 32767	0	num
Offs_PT1000_AI5	15663	WORD	-1	-	Ai5 PT1000 calibration offset	-32768 ... 32767	0	num
Offs_5V_AI5	15664	WORD	-1	-	Ai5 0-5V calibration offset	-32768 ... 32767	0	num
Offs_10V_AI5	15665	WORD	-1	-	Ai5 0-10V calibration offset	-32768 ... 32767	0	num
Offs_mA_AI5	15666	WORD	-1	-	Ai5 4-20mA calibration offset	-32768 ... 32767	0	num
Offs_Ntc_AI6	15667	WORD	-1	-	Ai6 NTC calibration offset	-32768 ... 32767	0	num
Offs_PT1000_AI6	15668	WORD	-1	-	Ai6 PT1000 calibration offset	-32768 ... 32767	0	num
Offs_5V_AI6	15669	WORD	-1	-	Ai6 0-5V calibration offset	-32768 ... 32767	0	num
Offs_10V_AI6	15670	WORD	-1	-	Ai6 0-10V calibration offset	-32768 ... 32767	0	num
Offs_mA_AI6	15671	WORD	-1	-	Ai6 4-20mA calibration offset	-32768 ... 32767	0	num
AO CALIBRATION folder								
Gain_10V_AO1	15684	WORD	-	-	AO1 0-10V calibration gain	0 ... 65535	32768	num
Gain_mA_AO1	15685	WORD	-	-	AO1 4-20mA calibration gain	0 ... 65535	32768	num
Gain_10V_AO2	15686	WORD	-	-	AO2 0-10V calibration gain	0 ... 65535	32768	num
Gain_mA_AO2	15687	WORD	-	-	AO2 4-20mA calibration gain	0 ... 65535	32768	num
Gain_10V_AO3	15688	WORD	-	-	AO3 0-10V calibration gain	0 ... 65535	32768	num
Gain_mA_AO3	15689	WORD	-	-	AO3 4-20mA calibration gain	0 ... 65535	32768	num
Gain_10V_AO4	15690	WORD	-	-	AO4 0-10V calibration gain	0 ... 65535	32768	num
Gain_mA_AO4	15691	WORD	-	-	AO4 4-20mA calibration gain	0 ... 65535	32768	num
Gain_10V_AO5	15692	WORD	-	-	AO5 0-10V calibration gain	0 ... 65535	32768	num
Gain_mA_AO5	15693	WORD	-	-	AO5 4-20mA calibration gain	0 ... 65535	32768	num
Offs_10V_AO1	15700	WORD	-1	-	AO1 0-10V calibration offset	-32768 ... 32767	0	num
Offs_mA_AO1	15701	WORD	-1	-	AO1 4-20mA calibration offset	-32768 ... 32767	0	num
Offs_10V_AO2	15702	WORD	-1	-	AO2 0-10V calibration offset	-32768 ... 32767	0	num
Offs_mA_AO2	15703	WORD	-1	-	AO2 4-20mA calibration offset	-32768 ... 32767	0	num
Offs_10V_AO3	15704	WORD	-1	-	AO3 0-10V calibration offset	-32768 ... 32767	0	num
Offs_mA_AO3	15705	WORD	-1	-	AO3 4-20mA calibration offset	-32768 ... 32767	0	num
Offs_10V_AO4	15706	WORD	-1	-	AO4 0-10V calibration offset	-32768 ... 32767	0	num

LABEL	PAR. VALUE ADDRESS	DATA SIZE	CPL	RESET	DESCRIPTION	RANGE	DEFAULT	U.M.
Offs_mA_AO4	15707	WORD	-1	-	AO4 4-20mA calibration offset	-32768 ... 32767	0	num
Offs_10V_AO5	15708	WORD	-1	-	AO5 0-10V calibration offset	-32768 ... 32767	0	num
Offs_mA_AO5	15709	WORD	-1	-	AO5 4-20mA calibration offset	-32768 ... 32767	0	num
ANALOG INPUTS folder								
Temp_UM	15725	WORD	-	Y	Temperature unit of measurement • 0 = °C; • 1 = °F	0, 1	0	num
Cfg_Ai1	15726	WORD	-	-	Type of analog input Ai1 • 0= NTC (NK103) • 1= DI • 2= NTC (103AT)	0 ... 2	2	num
Cfg_Ai2	15727	WORD	-	-	Type of analog input Ai2 See Cfg_Ai1	0 ... 2	2	num
Cfg_Ai3	15728	WORD	-	-	Type of analog input Ai3 • 0= NTC (NK103) • 1= DI • 2= NTC (103AT) • 3 = 4...20mA • 4=0-10V • 5=0-5V • 6=Pt1000 • 7=hΩ(NTC) • 8=daΩ(PT1000)	0 ... 8	3	num
Cfg_Ai4	15729	WORD	-	-	Type of analog input Ai4 See Cfg_Ai3	0 ... 8	3	num
Cfg_Ai5	15730	WORD	-	-	Type of analog input Ai5 See Cfg_Ai3	0 ... 8	3	num
Cfg_Ai6	15731	WORD	-	-	Type of analog input Ai6 See Cfg_Ai3	0 ... 8	3	num
FullScaleMin_Ai3	15736	WORD	-1	-	Analog input Ai3 start of scale value Note: Minimum full scale: for current probes, value at 4mA, for 0-10V voltage probes, value at 0V, for ratiometric probes (0-5V), value at 10% (corresponding to 0.5V).	-9999...+9999	0	

LABEL	PAR. VALUE ADDRESS	DATA SIZE	CPL	RESET	DESCRIPTION	RANGE	DEFAULT	U.M.
FullScaleMax_Ai3	15737	WORD	-	-	Analog input Ai3 full scale value Note: Maximum full scale for current probes, value at 20mA, for 0-10V voltage probes, value at 10V, for ratiometric probes (0-5V), value at 90% (corresponding to 4.5V).	-9999...+9999	1000	
FullScaleMin_Ai4	15738	WORD	-1	-	Analog input Ai4 start of scale value See FullScaleMin_Ai3	-9999...+9999	0	
FullScaleMax_Ai4	15739	WORD	-	-	Analog input Ai4 full scale value See FullScaleMax_Ai3	-9999...+9999	1000	
FullScaleMin_Ai5	15740	WORD	-1	-	Analog input Ai5 start of scale value See FullScaleMin_Ai3	-9999...+9999	0	
FullScaleMax_Ai5	15741	WORD	-	-	Analog input Ai5 full scale value See FullScaleMax_Ai3	-9999...+9999	1000	
FullScaleMin_Ai6	15742	WORD	-1	-	Analog input Ai6 start of scale value See FullScaleMin_Ai3	-9999...+9999	0	
FullScaleMaxAi6	15743	WORD	-	-	Analog input Ai6 full scale value See FullScaleMax_Ai3	-9999...+9999	1000	
Calibration_Ai1	15748	WORD	-1	-	Analog input Ai1 differential	-180 ... 180	0	°C/10 or °F/10
Calibration_Ai2	15749	WORD	-1	-	Analog input Ai2 differential	-180 ... 180	0	°C/10 or °F/10
Calibration_Ai3	15750	WORD	-1	-	Analog input Ai3 differential	-1000 ... 1000	0	
Calibration_Ai4	15751	WORD	-1	-	Analog input Ai4 differential	-1000 ... 1000	0	
Calibration_Ai5	15752	WORD	-1	-	Analog input Ai5 differential	-1000 ... 1000	0	
Calibration_Ai6	15753	WORD	-1	-	Analog input Ai6 differential	-1000 ... 1000	0	

LABEL	PAR. VALUE ADDRESS	DATA SIZE	CPL	RESET	DESCRIPTION	RANGE	DEFAULT	U.M.
ANALOG OUTPUTS VII folder								
Cfg_AO1_AO5	15758	WORD	-	Y	<p>Type of analog output AO1/AO5 AO1 and AO5 are configured in pairs. See SubCfg_AO5</p> <ul style="list-style-type: none"> • 0 = 4-20mA current analog output • 1 = ON/OFF output configured as 0/4...20mA switch (ON= max 20mA, OFF=0mA) for piloting switch loads such as ON/OFF. • 2=0-10V analog output - voltage <p>Note. AO4 and AO5 can be configured as Open Collector → A04=1, A01/A05=0 or 1, SubCfg_AO5=1</p>	0 ... 2	0	num
Cfg_AO2	15759	WORD	-	Y	<p>Type of analog output AO2 See Cfg_AO1_AO5</p>	0 ... 2	0	num
Cfg_AO3	15760	WORD	-	Y	<p>Type of analog output AO3 See Cfg_AO1_AO5</p>	0 ... 2	0	num
Cfg_AO4	15761	WORD	-	Y	<p>Type of analog output AO4</p>	0 ... 2	0	num
SubCfg_AO5	15762	WORD	-	Y	<p>Analog output AO5 sub-mode function Only applies if Cfg_AO1_AO5≠2</p> <ul style="list-style-type: none"> • 0 = 4-20mA current analog output • 1 = ON/OFF output configured as 0/4...20mA switch (ON= max 20mA, OFF=0mA) for piloting switch loads such as ON/OFF. <p>Note. AO4 and AO5 can be configured as Open Collector → A04=1, A01/A05=0 or 1, SubCfg_AO5=1</p>	0, 1	0	num

TM171PDM27● / TM171PBM27R parameters

LABEL	PAR. VALUE ADDRESS	DATA SIZE	CPL	RESET (Y/N)	DESCRIPTION	RANGE	DEFAULT	U.M.
ON BOARD RS485 folder								
Addr_RS485_OB	15774	WORD	-	Y	On-board RS485 serial address The actual address is determined by the sum of this value + the value of the dip switch.	0 ... 255	1	num
Proto_RS485_OB	15775	WORD	-	Y	On-board RS485 protocol selection <ul style="list-style-type: none"> • 2 = uNET • 3 = Modbus/RTU 	2 ... 3	3	num
Databit_RS485_OB	15776	WORD	-	Y	On-board RS485 data bit number Fixed setting 8	8 ... 8	8	num
Stopbit_RS485_OB	15777	WORD	-	Y	On-board RS485 stop bit number 1= 1 stop bit 2= 2 stop bit	1... 2	1	num
Parity_RS485_OB	15778	WORD	-	Y	On-board RS485 protocol parity 0= NULL <ul style="list-style-type: none"> • 1= ODD • 2= EVEN 	0 ... 2	2	num
Baud_RS485_OB	15779	WORD	-	Y	On-board RS485 protocol baudrate <ul style="list-style-type: none"> • 0=9600 baud • 1=19200 baud • 2=38400 baud • 3=57600 baud • 4=76800 baud • 5=115200 baud 	0 ... 5	2	num
ON BOARD CAN folder								
Addr_CAN_OB	15780	WORD	-	Y	On-board CAN serial address The actual address is determined by the sum of this value + the value of the dip switch.	1 ... 127	1	num
Baud_CAN_OB	15781	WORD	-	Y	On-board CAN protocol baudrate <ul style="list-style-type: none"> • 2=500 kbaud • 3=250 kbaud • 4=125 kbaud • 5=125 kbaud • 6=50 kbaud 	2 ... 6	2	num
CAN PLUGIN PASSIVE folder								
Addr_RS485_PI	15782	WORD	-	Y	RS485 passive plug-in serial address The actual address is determined by the sum of this value + the value of the dip switch.	0 ... 255	1	num

LABEL	PAR. VALUE ADDRESS	DATA SIZE	CPL	RESET (Y/N)	DESCRIPTION	RANGE	DEFAULT	U.M.
Proto_RS485_PI	15783	WORD	-	Y	RS485 passive plug-in protocol selection 2 = uNET 3 = Modbus/RTU	2 ... 3	3	num
Databit_RS485_PI	15784	WORD	-	Y	RS485 passive plug-in data bit number Fixed setting 8	8 ... 8	8	num
Stopbit_RS485_PI	15785	WORD	-	Y	RS485 passive plug-in stop bit number • 1= 1 stop bit • 2= 2 stop bit	1... 2	1	num
Parity_RS485_PI	15786	WORD	-	Y	RS485 passive plug-in protocol parity 0= NULL 1= ODD 2= EVEN	0 ... 2	2	num
Baud_RS485_PI	15787	WORD	-	Y	RS485 passive plug-in protocol baudrate • 0=9600 baud • 1=19200 baud • 2=38400 baud • 3=57600 baud • 4=76800 baud • 5=115200 baud	0 ... 5	2	num
Addr_CAN_PI	15788	WORD	-	Y	CAN passive plug-in serial address The actual address is determined by the sum of this value + the value of the dip switch.	1 ... 127	1	num
Baud_CAN_PI	15789	WORD	-	Y	CAN passive plug-in protocol baudrate • 2=500 kbaud • 3=250 kbaud • 4=125 kbaud • 5=125 kbaud • 6=50 kbaud	2 ... 6	2	num
RS232 PASSIVE PLUG-IN folder								
Addr_RS232_PI	15790	WORD	-	Y	RS232 passive plug-in serial address The actual address is determined by the sum of this value + the value of the dip switch.	0 ... 255	1	num
Proto_RS232_PI	15791	WORD	-	Y	RS232 passive plug-in protocol selection • 2 = uNET • 3 = Modbus/RTU	2 ... 3	3	num

LABEL	PAR. VALUE ADDRESS	DATA SIZE	CPL	RESET (Y/N)	DESCRIPTION	RANGE	DEFAULT	U.M.
Databit_RS232_PI	15792	WORD	-	Y	RS232 passive plug-in data bit number <ul style="list-style-type: none"> • 7= 7 bit • 8= 8 bit 	7 ... 8	8	num
Stopbit_RS232_PI	15793	WORD	-	Y	RS232 passive plug-in stop bit number <ul style="list-style-type: none"> • 1= 1 stop bit • 2= 2 stop bit 	1... 2	1	num
Parity_RS232_PI	15784	WORD	-	Y	RS232 passive plug-in protocol parity <ul style="list-style-type: none"> • 0= NULL • 1= ODD • 2= EVEN 	0 ... 2	2	num
Baud_RS232_PI	15795	WORD	-	Y	RS232 passive plug-in protocol baudrate <ul style="list-style-type: none"> • 0=9600 baud • 1=19200 baud • 2=38400 baud • 3=57600 baud • 4=76800 baud • 5=115200 baud 	0 ... 5	2	num

PASSIVE ETHERNET COMMUNICATION MODULE

ETHERNET configuration parameters for passive plug-in require configuration of the TCP/IP communication port (for example 502), the IP address, the gateway and the subnet mask

The 'Default Gateway' and 'Net mask' parameters are of no significance in the local point-to-point network.

For connections via a router the 'Default Gateway' parameters must match the IP address, as in the following example:

		Value			Value
Ip_1_ETH_PI	Ethernet Passive Plug-In IP address (part 1)	192	DefGtwy_1_ETH_PI	Default Gateway (part 1)	192
Ip_2_ETH_PI	Ethernet Passive Plug-In IP address (part 2)	168	DefGtwy_2_ETH_PI	Default Gateway (part 2)	168
Ip_3_ETH_PI	Ethernet Passive Plug-In IP address (part 3)	0	DefGtwy_3_ETH_PI	Default Gateway (part 3)	0
Ip_4_ETH_PI	Ethernet Passive Plug-In IP address (part 4)	100	DefGtwy_4_ETH_PI	Default Gateway (part 4)	1

The parameters necessary for the configuration of ports and protocols are these:

WebVisu allows the use of HTTP and TFTP servers.

Parameter	Description	Label
HTTP ports	HTTP HyperText Transfer Protocol. An HTTP server generally monitors port 80 using TCP protocol.	Port_HTTP_PI
TFTP ports	TFTP Trivial File Transfer Protocol. Protocol using basic FTP functionalities. Typical use: transfer of small files between hosts on a network. TFTP USES PORT 69	Port_TFTP_PI
DHCP protocol	DHCP Dynamic Host Configuration Protocol	EnableDHCP_ETH_PI
DNS system	DNS Domain Name System System for the conversion of host names, or network nodes, to IP addresses Used by TM171SW (SoMachineHVAC) to send text e-mails (strings)	PriDNS_1_ETH_PI
		PriDNS_2_ETH_PI
		PriDNS_3_ETH_PI
		PriDNS_4_ETH_PI
		SecDNS_1_ETH_PI
		SecDNS_2_ETH_PI
		SecDNS_3_ETH_PI
		SecDNS_4_ETH_PI

LABEL	PAR VALUE ADDRESS	DATA SIZE	CPL	RESET (Y/N)	DESCRIPTION	RANGE	DEFAULT	U.M.
ETHERNET PASSIVE PLUG-IN folder								
Port_TFTP_PI	15772	WORD	-	Y	TFTP port TFTP communication Port number Default 0 corresponds to port 69	0 ... 65535	0	num
Port_HTTP_PI	15796	WORD	-	Y	HTTP port HTTP communication Port number Default 0 corresponds to port 80	0 ... 65535	0	num
Port_ETH_PI	15797	WORD	-	Y	Port TCP/IP Modbus communication port. Port 502 for example	0 ... 65535	502	num
Ip_1_ETH_PI	15798	WORD	-	Y	Ethernet passive Plug-in IP address (part 1)	0 ... 255	10	num
Ip_2_ETH_PI	15799	WORD	-	Y	Ethernet passive Plug-in IP address (part 2)	0 ... 255	0	num
Ip_3_ETH_PI	15800	WORD	-	Y	Ethernet passive Plug-in IP address (part 3)	0 ... 255	0	num
Ip_4_ETH_PI	15801	WORD	-	Y	Ethernet passive Plug-in IP address (part 4)	0 ... 255	100	num
DefGtwy_1_ETH_PI	15802	WORD	-	Y	Default Gateway (part 1)	0 ... 255	192	num
DefGtwy_2_ETH_PI	15803	WORD	-	Y	Default Gateway (part 2)	0 ... 255	168	num
DefGtwy_3_ETH_PI	15804	WORD	-	Y	Default Gateway (part 3)	0 ... 255	0	num
DefGtwy_4_ETH_PI	15805	WORD	-	Y	Default Gateway (part 4)	0 ... 255	1	num
NetMsk_1_ETH_PI	15806	WORD	-	Y	Net mask (part 1)	0 ... 255	255	num
NetMsk_2_ETH_PI	15807	WORD	-	Y	Net mask (part 2)	0 ... 255	255	num
NetMsk_3_ETH_PI	15808	WORD	-	Y	Net mask (part 3)	0 ... 255	255	num
NetMsk_4_ETH_PI	15809	WORD	-	Y	Net mask (part 4)	0 ... 255	0	num
PriDNS_1_ETH_PI	15810	WORD	-	Y	Primary DNS server (part 1)	0 ... 255	194	num
PriDNS_2_ETH_PI	15811	WORD	-	Y	Primary DNS server (part 2)	0 ... 255	25	num
PriDNS_3_ETH_PI	15812	WORD	-	Y	Primary DNS server (part 3)	0 ... 255	2	num
PriDNS_4_ETH_PI	15813	WORD	-	Y	Primary DNS server (part 4)	0 ... 255	129	num
SecDNS_1_ETH_PI	15814	WORD	-	Y	Secondary DNS server (part 1)	0 ... 255	194	num

LABEL	PAR VALUE ADDRESS	DATA SIZE	CPL	RESET (Y/N)	DESCRIPTION	RANGE	DEFAULT	U.M.
SecDNS_2_ETH_PI	15815	WORD	-	Y	Secondary DNS server (part 2)	0 ... 255	25	num
SecDNS_3_ETH_PI	15816	WORD	-	Y	Secondary DNS server (part 3)	0 ... 255	2	num
SecDNS_4_ETH_PI	15817	WORD	-	Y	Secondary DNS server (part 4)	0 ... 255	130	num
EnableDHCP_ETH_PI	15819	WORD	-	Y	Enable DHCP	0 ... 1 (False, True)	False	flag
Modems folder								
Modem_RS232_PI	15820	BOOL	-	Y	Presence of Modem	0 ... 1	0	num
Modem_InitStr1	15821	19 BYTES	-	Y	Modem initialization string (part I)	*****	(1)	string
Modem_InitStr2	15831	19 BYTES	-	Y	Modem initialization string (part II)	*****		string
Modem_Hangup	15851	19 BYTES	-	Y	Hangup String	*****	ATH0	string
Display folder								
Hmi_Language	15819	WORD	-	Y	Display language	0 ... 65535	0	num
Par_ContrLCD	15723	WORD	-	Y	LCD Contrast Allows adjustment of the LCD display contrast.	0 ... 64	30	num
Par_BackLightTime	15724	WORD	-	Y	Backlight switch-on time Allows adjustment of LCD display switch-on time.	0 ... 3600	10	num
(1) AT&F&C&D2E0X1S0=0								

9.1.2. M171EP14R parameters

LABEL	PAR. VALUE ADDRESS	DATA SIZE	CPL	RESET (Y/N)	DESCRIPTION	RANGE	DEFAULT	U.M.
ACKNOWLEDGEMENT folder								
Par_TAB	15716	WORD	-	Y	Map code Note: read/write parameter	0 ... 65535	0	num
Par_POLI	15717	WORD	-	Y	Model Code Note: read/write parameter	0 ... 65535	2049	num
Par_PCH	15718	WORD	-	-	Model ID Code	0 ... 65535	262	num
AI CALIBRATION folder								
Gain_Ntc_AI1	15616	WORD	-	-	Ai1 NTC calibration gain	0 ... 65535	32768	num
Gain_Ntc_AI2	15617	WORD	-	-	Ai2 NTC calibration gain	0 ... 65535	32768	num
Gain_Ntc_AI3	15618	WORD	-	-	Ai3 NTC calibration gain	0 ... 65535	32768	num
Gain_Ntc_AI4	15619	WORD	-	-	Ai4 NTC calibration gain	0 ... 65535	32768	num
Offs_Ntc_AI1	15621	WORD	-1	-	Ai1 NTC calibration offset	-32768 ... 32767	0	num
Offs_Ntc_AI2	15622	WORD	-1	-	Ai2 NTC calibration offset	-32768 ... 32767	0	num
Offs_Ntc_AI3	15623	WORD	-1	-	Ai3 NTC calibration offset	-32768 ... 32767	0	num
Offs_Ntc_AI4	15624	WORD	-1	-	Ai4 NTC calibration offset	-32768 ... 32767	0	num
Gain_PTC_AI1	15626	WORD	-	-	Ai1 PTC calibration gain	0 ... 65535	32768	num
Gain_PTC_AI2	15627	WORD	-	-	Ai2 PTC calibration gain	0 ... 65535	32768	num
Gain_PTC_AI3	15628	WORD	-	-	Ai3 PTC calibration gain	0 ... 65535	32768	num
Gain_PTC_AI4	15629	WORD	-	-	Ai4 PTC calibration gain	0 ... 65535	32768	num
Offs_PTC_AI1	15631	WORD	-1	-	Ai1 PTC calibration offset	-32768 ... 32767	0	num
Offs_PTC_AI2	15632	WORD	-1	-	Ai2 PTC calibration offset	-32768 ... 32767	0	num
Offs_PTC_AI3	15633	WORD	-1	-	Ai3 PTC calibration offset	-32768 ... 32767	0	num
Offs_PTC_AI4	15634	WORD	-1	-	Ai4 PTC calibration offset	-32768 ... 32767	0	num
Gain_daOhm_AI1	15636	WORD	-	-	Ai1 daOhm calibration gain	0 ... 65535	32768	num
Gain_daOhm_AI2	15637	WORD	-	-	Ai2 daOhm calibration gain	0 ... 65535	32768	num
Gain_daOhm_AI3	15638	WORD	-	-	Ai3 daOhm calibration gain	0 ... 65535	32768	num
Gain_daOhm_AI4	15639	WORD	-	-	Ai4 daOhm calibration gain	0 ... 65535	32768	num
Offs_daOhm_AI1	15641	WORD	-1	-	Ai1 daOhm calibration offset	-32768 ... 32767	0	num
Offs_daOhm_AI2	15642	WORD	-1	-	Ai2 daOhm calibration offset	-32768 ... 32767	0	num
Offs_daOhm_AI3	15643	WORD	-1	-	Ai3 daOhm calibration offset	-32768 ... 32767	0	num
Offs_daOhm_AI4	15644	WORD	-1	-	Ai4 daOhm calibration offset	-32768 ... 32767	0	num
Gain_mA_AI1	15646	WORD	-	-	Ai1 4-20mA calibration gain	0 ... 65535	32768	num
Gain_mA_AI2	15647	WORD	-	-	Ai2 4-20mA calibration gain	0 ... 65535	32768	num

LABEL	PAR. VALUE ADDRESS	DATA SIZE	CPL	RESET (Y/N)	DESCRIPTION	RANGE	DEFAULT	U.M.
Gain_mA_AI3	15648	WORD	-	-	Ai3 4-20mA calibration gain	0 ... 65535	32768	num
Gain_mA_AI4	15649	WORD	-	-	Ai4 4-20mA calibration gain	0 ... 65535	32768	num
Offs_mA_AI1	15651	WORD	-1	-	Ai1 4-20mA calibration offset	-32768 ... 32767	0	num
Offs_mA_AI2	15652	WORD	-1	-	Ai2 4-20mA calibration offset	-32768 ... 32767	0	num
Offs_mA_AI3	15653	WORD	-1	-	Ai3 4-20mA calibration offset	-32768 ... 32767	0	num
Offs_mA_AI4	15654	WORD	-1	-	Ai4 4-20mA calibration offset	-32768 ... 32767	0	num
Gain_5V_Ratio_AI1	15656	WORD	-	-	Ai1 5V Ratiometric calibration gain	0 ... 65535	32768	num
Gain_5V_Ratio_AI2	15657	WORD	-	-	Ai2 5V Ratiometric calibration gain	0 ... 65535	32768	num
Gain_5V_Ratio_AI3	15658	WORD	-	-	Ai3 5V Ratiometric calibration gain	0 ... 65535	32768	num
Gain_5V_Ratio_AI4	15659	WORD	-	-	Ai4 5V Ratiometric calibration gain	0 ... 65535	32768	num
Offs_5V_Ratio_AI1	15661	WORD	-1	-	Ai1 5V Ratiometric calibration offset	-32768 ... 32767	0	num
Offs_5V_Ratio_AI2	15662	WORD	-1	-	Ai2 5V Ratiometric calibration offset	-32768 ... 32767	0	num
Offs_5V_Ratio_AI3	15663	WORD	-1	-	Ai3 5V Ratiometric calibration offset	-32768 ... 32767	0	num
Offs_5V_Ratio_AI4	15664	WORD	-1	-	Ai4 5V Ratiometric calibration offset	-32768 ... 32767	0	num
Gain_10V_AI1	15666	WORD	-	-	Ai1 0-10V calibration gain	0 ... 65535	32768	num
Gain_10V_AI2	15667	WORD	-	-	Ai2 0-10V calibration gain	0 ... 65535	32768	num
Gain_10V_AI3	15668	WORD	-	-	Ai3 0-10V calibration gain	0 ... 65535	32768	num
Gain_10V_AI4	15669	WORD	-	-	Ai4 0-10V calibration gain	0 ... 65535	32768	num
Offs_10V_AI1	15671	WORD	-1	-	Ai1 0-10V calibration offset	-32768 ... 32767	0	num
Offs_10V_AI2	15672	WORD	-1	-	Ai2 0-10V calibration offset	-32768 ... 32767	0	num
Offs_10V_AI3	15673	WORD	-1	-	Ai3 0-10V calibration offset	-32768 ... 32767	0	num
Offs_10V_AI4	15674	WORD	-1	-	Ai4 0-10V calibration offset	-32768 ... 32767	0	num
Gain_5V_AI1	15676	WORD	-	-	Ai1 0-5V calibration gain	0 ... 65535	32768	num
Gain_5V_AI2	15677	WORD	-	-	Ai2 0-5V calibration gain	0 ... 65535	32768	num
Gain_5V_AI3	15678	WORD	-	-	Ai3 0-5V calibration gain	0 ... 65535	32768	num
Gain_5V_AI4	15679	WORD	-	-	Ai4 0-5V calibration gain	0 ... 65535	32768	num
Offs_5V_AI1	15681	WORD	-1	-	Ai1 0-5V calibration offset	-32768 ... 32767	0	num
Offs_5V_AI2	15682	WORD	-1	-	Ai2 0-5V calibration offset	-32768 ... 32767	0	num
Offs_5V_AI3	15683	WORD	-1	-	Ai3 0-5V calibration offset	-32768 ... 32767	0	num
Offs_5V_AI4	15684	WORD	-1	-	Ai4 0-5V calibration offset	-32768 ... 32767	0	num
Gain_PT1000_AI1	15686	WORD	-	-	Ai1 PT1000 calibration gain	0 ... 65535	32768	num
Gain_PT1000_AI2	15687	WORD	-	-	Ai2 PT1000 calibration gain	0 ... 65535	32768	num
Gain_PT1000_AI3	15688	WORD	-	-	Ai3 PT1000 calibration gain	0 ... 65535	32768	num
Gain_PT1000_AI4	15689	WORD	-	-	Ai4 PT1000 calibration gain	0 ... 65535	32768	num

LABEL	PAR. VALUE ADDRESS	DATA SIZE	CPL	RESET (Y/N)	DESCRIPTION	RANGE	DEFAULT	U.M.
Offs_PT1000_AI1	15691	WORD	-1	-	Ai1 PT1000 calibration offset	-32768 ... 32767	0	num
Offs_PT1000_AI2	15692	WORD	-1	-	Ai2 PT1000 calibration offset	-32768 ... 32767	0	num
Offs_PT1000_AI3	15693	WORD	-1	-	Ai3 PT1000 calibration offset	-32768 ... 32767	0	num
Offs_PT1000_AI4	15694	WORD	-1	--	Ai4 PT1000 calibration offset	-32768 ... 32767	0	num
AO CALIBRATION folder								
Gain_10V_AO1	15696	WORD	-	-	AO1 0-10V calibration gain	0 ... 65535	32768	num
Gain_10V_AO2	15697	WORD	-	-	AO2 0-10V calibration gain	0 ... 65535	32768	num
Offs_10V_AO1	15698	WORD	-1	-	AO1 0-10V calibration offset	-32768 ... 32767	0	num
Offs_10V_AO2	15699	WORD	-1	-	AO2 0-10V calibration offset	-32768 ... 32767	0	num
ANALOG INPUTS folder								
Temp_UM	15725	WORD	-	Y	Temperature unit of measurement • 0 = °C; • 1 = °F	0, 1	0	num
Cfg_Ai1	15726	WORD	-	-	Type of analog input Ai1 • 0= NTC (NK103) • 1= DI • 2= NTC (103AT) • 3 = 4...20mA • 4=0-10V • 5=0-5V Ratiometric • 6=Pt1000 • 7=hΩ(NTC) • 8=daΩ(PT1000) • PTC • 10=0-5V	0 ... 10	3	num
Cfg_Ai2	15727	WORD	-	-	Type of analog input Ai2 See Cfg_Ai1	0 ... 10	3	num
Cfg_Ai3	15728	WORD	-	-	Type of analog input Ai3 See Cfg_Ai1	0 ... 10	2	num
Cfg_Ai4	15729	WORD	-	-	Type of analog input Ai4 See Cfg_Ai1	0 ... 10	2	num
FullScaleMin_Ai1	15736	WORD	-1	-	Analog input Ai1 start of scale value	-9999...+9999	0	
FullScaleMax_Ai1	15737	WORD	-	-	Analog input Ai1 full scale value	-9999...+9999	1000	
FullScaleMin_Ai2	15738	WORD	-1	-	Analog input Ai2 start of scale value See FullScaleMin_Ai1	-9999...+9999	0	

LABEL	PAR. VALUE ADDRESS	DATA SIZE	CPL	RESET (Y/N)	DESCRIPTION	RANGE	DEFAULT	U.M.
FullScaleMax_A2	15739	WORD	-	-	Analog input Ai2 full scale value See FullScaleMax_Ai1	-999...+999	1000	
FullScaleMin_Ai3	15740	WORD	-1	-	Analog input Ai3 start of scale value See FullScaleMin_Ai1	-9999...+9999	0	
FullScaleMax_Ai3	15741	WORD	-	-	Analog input Ai3 full scale value See FullScaleMax_Ai1	-999...+999	1000	
FullScaleMin_Ai4	15742	WORD	-1	-	Analog input Ai4 start of scale value See FullScaleMin_Ai1	-9999...+9999	0	
FullScaleMaxAi4	15743	WORD	-	-	Analog input Ai4 full scale value See FullScaleMax_Ai1	-999...+999	100	
Calibration_Ai1	15748	WORD	-1	-	Analog input Ai1 differential	-180 ... 180	0	°C/10 or °F/10
Calibration_Ai2	15749	WORD	-1	-	Analog input Ai2 differential	-180 ... 180	0	°C/10 or °F/10
Calibration_Ai3	15750	WORD	-1	-	Analog input Ai3 differential	-1000 ... 1000	0	
Calibration_Ai4	15751	WORD	-1	-	Analog input Ai4 differential	-1000 ... 1000	0	
SubCfg_AI1	16010	WORD	-	Y	Analog input Ai5 sub-mode function <ul style="list-style-type: none"> • 0 = Low Pass Filter disabled, analog value in raw points • 1 = Low Pass Filter disabled, analog value converted • 2 = Low Pass Filter enabled, analog value in raw points • 1 = Low Pass Filter enabled, analog value converted 	0 ... 3	3	num
SubCfg_AI2	16011	WORD	-	Y	See SubCfg_AI1	0 ... 3	3	num
SubCfg_AI3	16012	WORD	-	Y	See SubCfg_AI1	0 ... 3	3	num
SubCfg_AI4	16013	WORD	-	Y	See SubCfg_AI1	0 ... 3	3	num

9.1.3. M171 Performance Flush parameters

LABEL	PAR VALUE ADDRESS	DATA SIZE	CPL	RESET (Y/N)	DESCRIPTION	RANGE	DEFAULT	U.M.
ACKNOWLEDGEMENT folder								
Par_TAB	15716	WORD	-	Y	Map code Note: read/write parameter	0 ... 65535	0	num
Par_POLI	15717	WORD	-	Y	Model Code Note: read/write parameter	0 ... 65535	2049	num
Par_PARMOD	15719	BOOL	-	-	Parameter changed Flag indicating change to default settings. • 0= map not modified. • 1= at least one parameter has been changed from the original configuration.	0 ... 1	0	num
AI CALIBRATION folder								
Gain_Ntc_AI1	15616	WORD	-	-	Ai1 NTC calibration gain	0 ... 65535	32768	num
Gain_Ntc_AI2	15617	WORD	-	-	Ai2 NTC calibration gain	0 ... 65535	32768	num
Gain_5V_AI3	15620	WORD	-	-	Ai3 0-5V calibration gain	0 ... 65535	32768	num
Gain_10V_AI3	15621	WORD	-	-	Ai3 0-10V calibration gain	0 ... 65535	32768	num
Gain_mA_AI3	15622	WORD	-	-	Ai3 4-20mA calibration gain	0 ... 65535	32768	num
Offs_Ntc_AI1	15650	WORD	-1	-	Ai1 NTC calibration offset	-32768 ... 32767	0	num
Offs_Ntc_AI2	15651	WORD	-1	-	Ai2 NTC calibration offset	-32768 ... 32767	0	num
Offs_5V_AI3	15654	WORD	-1	-	Ai3 0-5V calibration offset	-32768 ... 32767	0	num
Offs_10V_AI3	15655	WORD	-1	-	Ai3 0-10V calibration offset	-32768 ... 32767	0	num
Offs_mA_AI3	15656	WORD	-1	-	Ai3 4-20mA calibration offset	-32768 ... 32767	0	num
ANALOG INPUTS folder								
Temp_UM	15725	WORD	-	Y	Temperature unit of measure • 0 = °C; • 1 = °F	0, 1	0	num
Cfg_AI1	15726	WORD	-	-	Type of analog input Ai1 • 0= NTC (NK103) • 1= DI • 2= NTC (103AT)	0 ... 2	2	num
Cfg_Ai2	15727	WORD	-	-	Type of analog input Ai2 See Cfg_AI1	0 ... 2	2	num
Cfg_Ai3	15728	WORD	-	-	Type of analog input Ai3 • 3 = 4...20mA • 4=0-10V • 5=0-5V	3 ... 5	3	num

LABEL	PAR VALUE ADDRESS	DATA SIZE	CPL	RESET (Y/N)	DESCRIPTION	RANGE	DEFAULT	U.M.
Cfg_Ai4	15729	WORD	-	-	Type of analog input Ai4 See Cfg_Ai3	3 ... 5	3	num
FullScaleMin_Ai3	15736	WORD	-1	-	Analog input Ai3 start of scale value N.B.: Minimum full scale: for current probes, value at 4mA, for 0-10V voltage probes, value at 0V, 10% for (0-5V) probes, value at 10% (corresponding to 0.5V).	-9999...+9999	0	
FullScaleMax_Ai3	15737	WORD	-1	-	Analog input Ai3 full scale value N.B.: Maximum full scale for current probes, value at 20mA, for 0-10V voltage probes, value at 10V, for (0-5V) probes, value at 90% (corresponding to 4.5V).	-9999...+9999	1000	
Calibration_Ai1	15748	WORD	-1	-	Analog input Ai1 differential	-180 ... 180	0	°C/10 or °F/10
Calibration_Ai2	15749	WORD	-1	-	Analog input Ai2 differential	-180 ... 180	0	°C/10 or °F/10
Calibration_Ai3	15750	WORD	-1	-	Analog input Ai3 differential	-1000 ... 1000	0	
Calibration_Ai4	15751	WORD	-1	-	Analog input Ai4 differential	-1000 ... 1000	0	
Compensation_AI1	15752	WORD	-1	-	Internal compensation AI1	-1000 ... 1000 °C/10	0	°C/10
Compensation_AI4	15753	WORD	-1	-	Internal compensation AI4	-1000 ... 1000 °C/10	0	°C/10
RS485 ON BOARD folder								
Addr_RS485_OB	15774	WORD	-	Y	On-board RS485 serial address The actual address is determined by the sum of this value + the value of the dip switch.	0 ... 255	1	num
Proto_RS485_OB	15775	WORD	-	Y	On-board RS485 protocol selection • 2 = uNET • 3 = Modbus/RTU	2 ... 3	2	num
Databit_RS485_OB	15776	WORD	-	Y	On-board RS485 data bit number Fixed setting 8	8 ... 8	8	num
Stopbit_RS485_OB	15777	WORD	-	Y	On-board RS485 stop bit number • 1= 1 stop bit • 2= 2 stop bits	1... 2	1	num
Parity_RS485_OB	15778	WORD	-	Y	On-board RS485 protocol parity • 0= NULL • 1= ODD • 2= EVEN	0 ... 2	2	num

LABEL	PAR VALUE ADDRESS	DATA SIZE	CPL	RESET (Y/N)	DESCRIPTION	RANGE	DEFAULT	U.M.
Baud_RS485_OB	15779	WORD	-	Y	On-board RS485 protocol baudrate <ul style="list-style-type: none"> • 0=9600 baud • 1=19200 baud • 2=38400 baud • 3=57600 baud • 4=76800 baud • 5=115200 baud 	0 ... 5	2	num
ON BOARD CAN folder								
Addr_CAN_OB	15780	WORD	-	Y	On-board CAN serial address The actual address is determined by the sum of this value + the value of the dip switch.	1 ... 127	1	num
Baud_CAN_OB	15781	WORD	-	Y	On-board CAN protocol baudrate <ul style="list-style-type: none"> 2=500 kbaud 3=250 kbaud 4=125 kbaud 5=125 kbaud 6=50 kbaud 	2 ... 6	2	num

ON BOARD ETHERNET

The parameters necessary for the configuration of ports and protocols are these:

WebVisu allows the use of HTTP and TFTP servers.

Parameter	Description	Label
HTTP ports	HTTP HyperText Transfer Protocol. An HTTP server generally monitors port 80 using TCP protocol.	Port_HTTP
TFTP ports	TFTP Trivial File Transfer Protocol. Protocol using basic FTP functionalities. Typical use: transfer of small files between hosts on a network. TFTP USES PORT 69	Port_TFTP
DHCP protocol	DHCP Dynamic Host Configuration Protocol	EnableDHCP_ETH
DNS system	DNS Domain Name System System for the conversion of host names, or network nodes, to IP addresses Used by TM171SW (SoMachineHVAC) to send text e-mails (strings)	PriDNS_1_ETH
		PriDNS_2_ETH
		PriDNS_3_ETH
		PriDNS_4_ETH
		SecDNS_1_ETH
		SecDNS_2_ETH
		SecDNS_3_ETH
		SecDNS_4_ETH

LABEL	PAR VALUE ADDRESS	DATA SIZE	CPL	RESET (Y/N)	DESCRIPTION	RANGE	DEFAULT	U.M.
ETHERNET ON BOARD folder								
Port_TFTP	15772	WORD	-	Y	TFTP port TFTP communication Port number Default 0 corresponds to port 69	0 ... 65535	0	num
Port_HTTP	15796	WORD	-	Y	HTTP port HTTP communication Port number Default 0 corresponds to port 80	0 ... 65535	0	num
Port_ETH	15797	WORD	-	Y	Port TCP/IP Modbus communication port. Port 502 for example	0 ... 65535	502	num
Ip_1_ETH	15798	WORD	-	Y	On-board Ethernet passive IP address (part 1)	0 ... 255	10	num
Ip_2_ETH	15799	WORD	-	Y	On-board Ethernet passive IP address (part 2)	0 ... 255	0	num
Ip_3_ETH	15800	WORD	-	Y	On-board Ethernet passive IP address (part 3)	0 ... 255	0	num
Ip_4_ETH	15801	WORD	-	Y	On-board Ethernet passive IP address (part 4)	0 ... 255	100	num
DefGtwy_1_ETH	15802	WORD	-	Y	Default Gateway (part 1)	0 ... 255	192	num
DefGtwy_2_ETH	15803	WORD	-	Y	Default Gateway (part 2)	0 ... 255	168	num
DefGtwy_3_ETH	15804	WORD	-	Y	Default Gateway (part 3)	0 ... 255	0	num
DefGtwy_4_ETH	15805	WORD	-	Y	Default Gateway (part 4)	0 ... 255	1	num
NetMsk_1_ETH	15806	WORD	-	Y	Net mask (part 1)	0 ... 255	255	num
NetMsk_2_ETH	15807	WORD	-	Y	Net mask (part 2)	0 ... 255	255	num
NetMsk_3_ETH	15808	WORD	-	Y	Net mask (part 3)	0 ... 255	255	num
NetMsk_4_ETH	15809	WORD	-	Y	Net mask (part 4)	0 ... 255	0	num
PriDNS_1_ETH	15810	WORD	-	Y	Primary DNS server (part 1)	0 ... 255	194	num
PriDNS_2_ETH	15811	WORD	-	Y	Primary DNS server (part 2)	0 ... 255	25	num
PriDNS_3_ETH	15812	WORD	-	Y	Primary DNS server (part 3)	0 ... 255	2	num
PriDNS_4_ETH	15813	WORD	-	Y	Primary DNS server (part 4)	0 ... 255	129	num
SecDNS_1_ETH	15814	WORD	-	Y	Secondary DNS server (part 1)	0 ... 255	194	num
SecDNS_2_ETH	15815	WORD	-	Y	Secondary DNS server (part 2)	0 ... 255	25	num
SecDNS_3_ETH	15816	WORD	-	Y	Secondary DNS server (part 3)	0 ... 255	2	num
SecDNS_4_ETH	15817	WORD	-	Y	Secondary DNS server (part 4)	0 ... 255	130	num
EnableDHCP_ETH	15819	WORD	-	Y	Enable DHCP	0 ... 1 (False, True)	False	flag
Display folder								
Hmi_Language	15819	WORD	-	-	Display language 0 = Italian 1 = English 2 = French 3 = German 4 = Spanish	0 ... 65535	0	num

LABEL	PAR VALUE ADDRESS	DATA SIZE	CPL	RESET (Y/N)	DESCRIPTION	RANGE	DEFAULT	U.M.
Par_ContrLCD	15723	WORD	-	Y	LCD Contrast Allows adjustment of the LCD display contrast.	0 ... 64	30	num
Par_BackLightTime	15724	WORD	-	-	Backlight switch-on time Allows adjustment of LCD display switch-on time.	0 ... 3600	10	sec
Buzzer folder								
Buzzer_Mode	15990	WORD	-	-	Buzzer mode 0= always off 1= beep per key	0 ... 1	0	num
HMI Management folder								
Hmi_Language	15989	WORD				0 ... 65535	0	num
HmiList_Current	15820	WORD	-	-	Current HMI 0= HMI remote 1 1= HMI remote 2 2= HMI remote 3 3= HMI remote 4 4= HMI remote 5 5= HMI remote 6 6= HMI remote 7 7= HMI remote 8 8= HMI remote 9 9= HMI remote 10 10 = not used 11= Local HMI	0 ... 11	11	num
If HmiList_Current=11 the following folders/parameters are NOT USED.								
HMI remote 1 folder								
HmiList_ID_1	15821	WORD	-	-	HMI remote 1 navigation ID list	0 ... 254	0	num
HmiList_Res_1	15833	WORD	-	-	HMI remote 1 navigation resource type HMI remote 1 navigation resource type 1=RTU (RS485 Modbus RTU) 2=TCP (Modbus TCP) 3=CAN (CAN)	1 ... 3	3	num
HmiList_Addr_1	15845	WORD	-	-	HMI remote 1 navigation resource address for CAN, RTU and TCP (IP part 1)	0 ... 255	0	num
HmiList_Addr_2	15846	WORD	-	-	HMI remote 1 navigation resource address for TCP (IP part 2)	0 ... 255	0	num
HmiList_Addr_3	15847	WORD	-	-	HMI remote 1 navigation resource address for TCP (IP part 3)	0 ... 255	0	num
HmiList_Addr_4	15848	WORD	-	-	HMI remote 1 navigation resource address for TCP (IP part 4)	0 ... 255	0	num
HmiList_File_1	15893	15 byte	-	-	HMI remote 1 navigation file (DOS 8.3 uppercase format)	*****		string
HMI remote 2 folder								
HmiList_ID_2	15822	WORD	-	-	HMI remote 2 navigation ID list	0 ... 254	0	num

LABEL	PAR VALUE ADDRESS	DATA SIZE	CPL	RESET (Y/N)	DESCRIPTION	RANGE	DEFAULT	U.M.
HmiList_Res_2	15834	WORD	-	-	HMI remote 2 navigation resource type 1=RTU (RS485 Modbus RTU) 2=TCP (Modbus TCP) 3=CAN (CAN)	1 ... 3	3	num
HmiList_Addr_1	15849	WORD	-	-	HMI remote 2 navigation resource address for CAN, RTU and TCP (IP part 1)	0 ... 255	0	num
HmiList_Addr_2	15850	WORD	-	-	HMI remote 2 navigation resource address for TCP (IP part 2)	0 ... 255	0	num
HmiList_Addr_3	15851	WORD	-	-	HMI remote 2 navigation resource address for TCP (IP part 3)	0 ... 255	0	num
HmiList_Addr_4	15852	WORD	-	-	HMI remote 2 navigation resource address for TCP (IP part 4)	0 ... 255	0	num
HmiList_File_2	15901	15 byte	-	-	HMI remote 2 navigation file (DOS 8.3 uppercase format)	*****		string
HMI remote 3 folder								
HmiList_Res_3	15835	WORD	-	-	HMI remote 3 navigation resource type 1=RTU (RS485 Modbus RTU) 2=TCP (Modbus TCP) 3=CAN (CAN)	1 ... 3	3	num
HmiList_Addr_1	15853	WORD	-	-	HMI remote 3 navigation resource address for CAN, RTU and TCP (IP part 1)	0 ... 255	0	num
HmiList_Addr_2	15854	WORD	-	-	HMI remote 3 navigation resource address for TCP (IP part 2)	0 ... 255	0	num
HmiList_Addr_3	15855	WORD	-	-	HMI remote 3 navigation resource address for TCP (IP part 3)	0 ... 255	0	num
HmiList_Addr_4	15856	WORD	-	-	HMI remote 3 navigation resource address for TCP (IP part 4)	0 ... 255	0	num
HmiList_File_3	15909	15 byte	-	-	HMI remote 3 navigation file (DOS 8.3 uppercase format)	*****		string
HMI remote 4 folder								
HmiList_ID_4	15822	WORD	-	-	HMI remote 4 navigation ID list	0 ... 254	0	num
HmiList_Res_4	15836	WORD	-	-	HMI remote 4 navigation resource type 1=RTU (RS485 Modbus RTU) 2=TCP (Modbus TCP) 3=CAN (CAN)	1 ... 3	3	num
HmiList_Addr_1	15857	WORD	-	-	HMI remote 4 navigation resource address for CAN, RTU and TCP (IP part 1)	0 ... 255	0	num
HmiList_Addr_2	15859	WORD	-	-	HMI remote 4 navigation resource address for TCP (IP part 2)	0 ... 255	0	num
HmiList_Addr_3	15859	WORD	-	-	HMI remote 4 navigation resource address for TCP (IP part 3)	0 ... 255	0	num

LABEL	PAR VALUE ADDRESS	DATA SIZE	CPL	RESET (Y/N)	DESCRIPTION	RANGE	DEFAULT	U.M.
HmiList_Addr_4	15860	WORD	-	-	HMI remote 4 navigation resource address for TCP (IP part 4)	0 ... 255	0	num
HmiList_File_4	15917	15 byte	-	-	HMI remote 4 navigation file (DOS 8.3 uppercase format)	*****		string
HMI remote 5 folder								
HmiList_ID_5	15825	WORD	-	-	HMI remote 5 navigation ID list	0 ... 254	0	num
HmiList_Res_5	15837	WORD	-	-	HMI remote 5 navigation resource type 1=RTU (RS485 Modbus RTU) 2=TCP (Modbus TCP) 3=CAN (CAN)	1 ... 3	3	num
HmiList_Addr_1	15861	WORD	-	-	HMI remote 5 navigation resource address for CAN, RTH and TCP (IP part 1)	0 ... 255	0	num
HmiList_Addr_2	15862	WORD	-	-	HMI remote 5 navigation resource address for TCP (IP part 2)	0 ... 255	0	num
HmiList_Addr_3	15863	WORD	-	-	HMI remote 5 navigation resource address for TCP (IP part 3)	0 ... 255	0	num
HmiList_Addr_4	15864	WORD	-	-	HMI remote 5 navigation resource address for TCP (IP part 4)	0 ... 255	0	num
HmiList_File_5	15925	15 byte	-	-	HMI remote 5 navigation file (DOS 8.3 uppercase format)	*****		string
HMI remote 6 folder								
HmiList_ID_6	15826	WORD	-	-	HMI remote 6 navigation ID list	0 ... 254	0	num
HmiList_Res_6	15838	WORD	-	-	HMI remote 6 navigation resource type 1=RTU (RS485 Modbus RTU) 2=TCP (Modbus TCP) 3=CAN (CAN)	1 ... 3	3	num
HmiList_Addr_1	15865	WORD	-	-	HMI remote 6 navigation resource address for CAN, RTH and TCP (IP part 1)	0 ... 255	0	num
HmiList_Addr_2	15866	WORD	-	-	HMI remote 6 navigation resource address for TCP (IP part 2)	0 ... 255	0	num
HmiList_Addr_3	15867	WORD	-	-	HMI remote 6 navigation resource address for TCP (IP part 3)	0 ... 255	0	num
HmiList_Addr_4	15868	WORD	-	-	HMI remote 6 navigation resource address for TCP (IP part 4)	0 ... 255	0	num
HmiList_File_6	15933	15 byte	-	-	HMI remote 6 navigation file (DOS 8.3 uppercase format)	*****		string
HMI remote 7 folder								
HmiList_ID_7	15827	WORD	-	-	HMI remote 7 navigation ID list	0 ... 254	0	num
HmiList_Res_7	15839	WORD	-	-	HMI remote 7 navigation resource type 1=RTU (RS485 Modbus RTU) 2=TCP (Modbus TCP) 3=CAN (CAN)	1 ... 3	3	num

LABEL	PAR VALUE ADDRESS	DATA SIZE	CPL	RESET (Y/N)	DESCRIPTION	RANGE	DEFAULT	U.M.
HmiList_Addr_1	15869	WORD	-	-	HMI remote 7 navigation resource address for CAN, RTU and TCP (IP part 1)	0 ... 255	0	num
HmiList_Addr_2	15870	WORD	-	-	HMI remote 7 navigation resource address for TCP (IP part 2)	0 ... 255	0	num
HmiList_Addr_3	15871	WORD	-	-	HMI remote 7 navigation resource address for TCP (IP part 3)	0 ... 255	0	num
HmiList_Addr_4	15872	WORD	-	-	HMI remote 7 navigation resource address for TCP (IP part 4)	0 ... 255	0	num
HmiList_File_7	15941	15 byte			HMI remote 7 navigation file (DOS 8.3 uppercase format)	*****		string
HMI remote 8 folder								
HmiList_ID_8	15828	WORD	-	-	HMI remote 8 navigation ID list	0 ... 254	0	num
HmiList_Res_8	15840	WORD	-	-	HMI remote 8 navigation resource type 1=RTU (RS485 Modbus RTU) 2=TCP (Modbus TCP) 3=CAN (CAN)	1 ... 3	3	num
HmiList_Addr_1	15873	WORD	-	-	HMI remote 8 navigation resource address for CAN, RTU and TCP (IP part 1)	0 ... 255	0	num
HmiList_Addr_2	15874	WORD	-	-	HMI remote 8 navigation resource address for TCP (IP part 2)	0 ... 255	0	num
HmiList_Addr_3	15875	WORD	-	-	HMI remote 8 navigation resource address for TCP (IP part 3)	0 ... 255	0	num
HmiList_Addr_4	15876	WORD	-	-	HMI remote 8 navigation resource address for TCP (IP part 4)	0 ... 255	0	num
HmiList_File_8	15949	15 byte	-	-	HMI remote 8 navigation file (DOS 8.3 uppercase format)	*****		string
HMI remote 9 folder								
HmiList_ID_9	15829	WORD	-	-	HMI remote 9 navigation ID list	0 ... 254	0	num
HmiList_Res_9	15841	WORD	-	-	HMI remote 9 navigation resource type 1=RTU (RS485 Modbus RTU) 2=TCP (Modbus TCP) 3=CAN (CAN)	1 ... 3	3	num
HmiList_Addr_1	15877	WORD	-	-	HMI remote 9 navigation resource address for CAN, RTU and TCP (IP part 1)	0 ... 255	0	num
HmiList_Addr_2	15878	WORD	-	-	HMI remote 9 navigation resource address for TCP (IP part 2)	0 ... 255	0	num
HmiList_Addr_3	15879	WORD	-	-	HMI remote 9 navigation resource address for TCP (IP part 3)	0 ... 255	0	num
HmiList_Addr_4	15880	WORD	-	-	HMI remote 9 navigation resource address for TCP (IP part 4)	0 ... 255	0	num
HmiList_File_9	15957	15 byte	-	-	HMI remote 9 navigation file (DOS 8.3 uppercase format)	*****		string

LABEL	PAR VALUE ADDRESS	DATA SIZE	CPL	RESET (Y/N)	DESCRIPTION	RANGE	DEFAULT	U.M.
HMI remote 10 folder								
HmiList_ID_10	15830	WORD	-	-	HMI remote 10 navigation ID list	0 ... 254	0	num
HmiList_Res_10	15842	WORD	-	-	HMI remote 10 navigation resource type 1=RTU (RS485 Modbus RTU) 2=TCP (Modbus TCP) 3=CAN (CAN)	1 ... 3	3	num
HmiList_Addr_1	15881	WORD	-	-	HMI remote 10 navigation resource address for CAN, RTU and TCP (IP part 1)	0 ... 255	0	num
HmiList_Addr_2	15882	WORD	-	-	HMI remote 10 navigation resource address for TCP (IP part 2)	0 ... 255	0	num
HmiList_Addr_3	15883	WORD	-	-	HMI remote 10 navigation resource address for TCP (IP part 3)	0 ... 255	0	num
HmiList_Addr_4	15884	WORD	-	-	HMI remote 10 navigation resource address for TCP (IP part 4)	0 ... 255	0	num
HmiList_File_10	15965	15 byte	-	-	HMI remote 10 navigation file (DOS 8.3 uppercase format)	*****		string

CHAPTER 10

Programming of the TM171EP14R

The **TM171ADMI** and **TM171AMFK** are accessories that can be connected to the **M171 Performance TM171EP14R expansion** (target) serial port to make a quick programming of :

- Targets parameters (upload and download of a parameter map to/from one or more targets of the same type)
- Targets BIOS

Connection of Programming Cable (TM171ADMI)

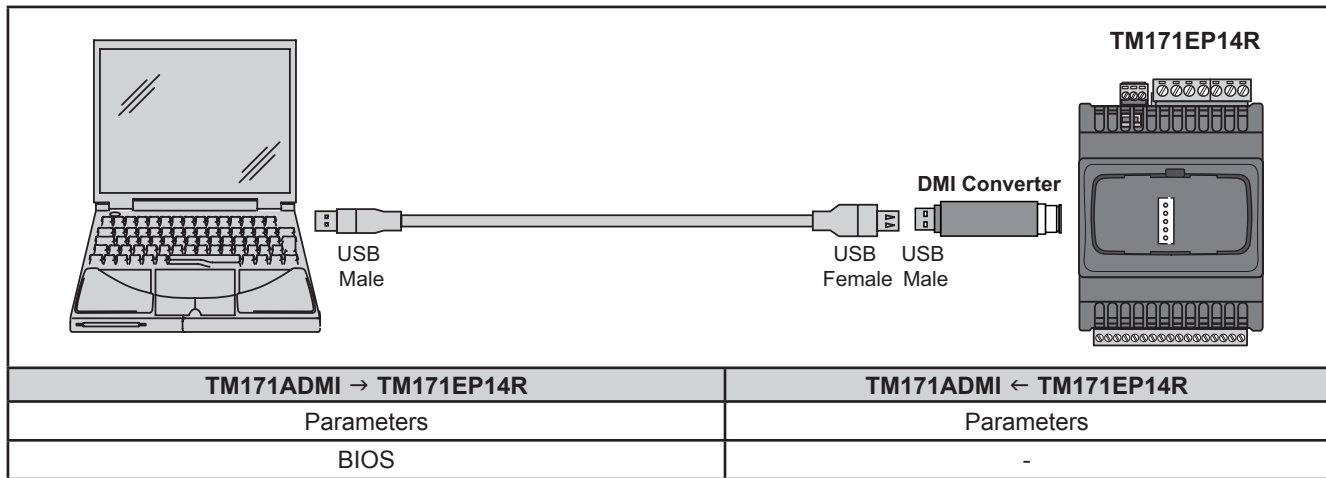

Fig. 64. Connections between TM171ADMI Converter and the Modicon TM171EP14R

NOTE: When supplying power to the expansion module from the PC, **TM171EP14R** must not be connected to earth. If a ground (earth) connection exists for the PC as well as the **TM171EP14R** a ground loop condition could develop and render either PC or the **TM171EP14R** inoperable.

NOTICE

INOPERABLE EQUIPMENT

If you are unsure whether the TM171EP14R is connected to an SELV power supply, disconnect the power supply connection to the TM171EP14R before connecting a PC.

Failure to follow these instructions can result in equipment damage.

Connection of Multi Function Key (TM171AMFK)

To connect **TM171AMFK** to **TM171ADMI** the **BLUE** cable is used.

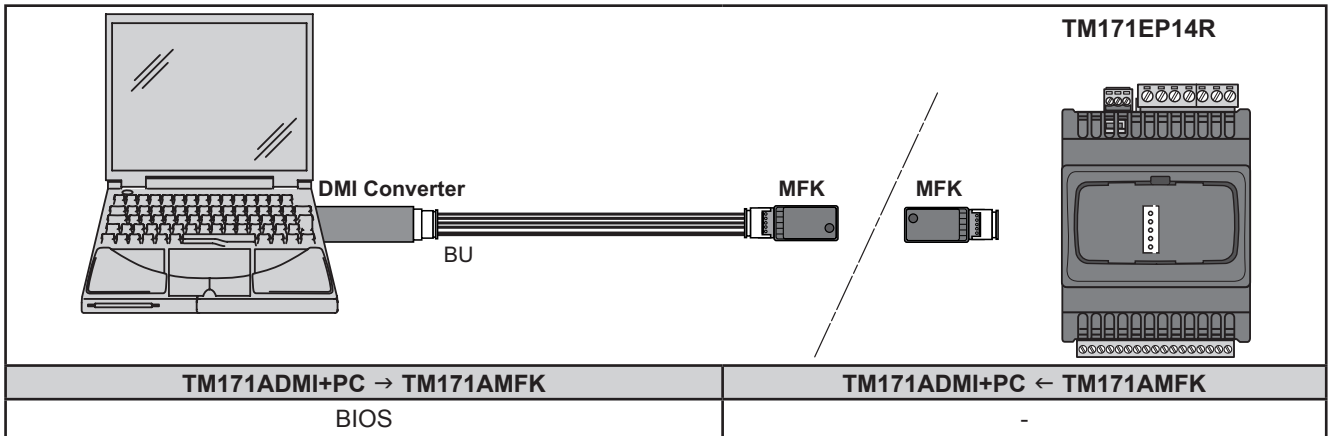

Fig. 65. Connections between TM171AMFK and TM171ADMI Converter + PC

⚠ WARNING

UNINTENDED EQUIPMENT OPERATION

- Connect the programming cable to the PC first, then to the programming port of the controller.
- Disconnect the programming cable from the controller before disconnecting it from the PC.

Failure to follow these instructions can result in death, serious injury, or equipment damage

