

SoMachine HVAC

Booster Pumping Application

Functions

Pumping Library Guide

09/2015

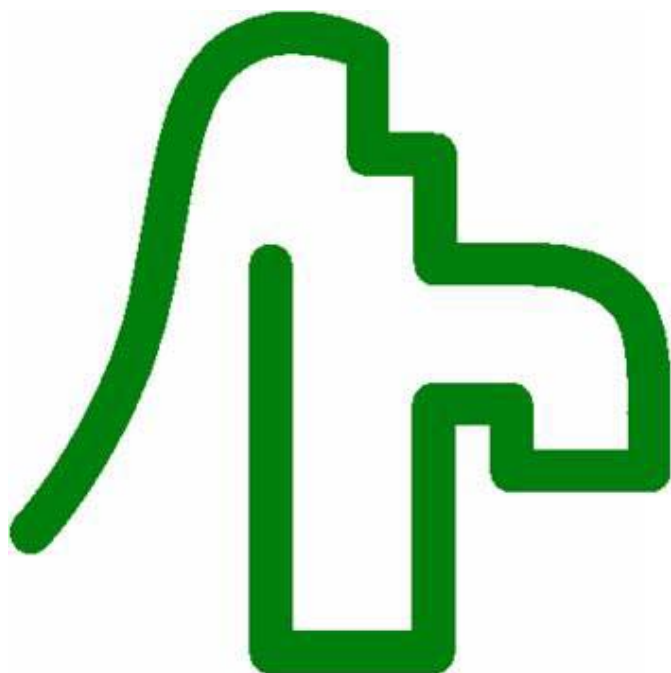

EIO000002171.00

www.schneider-electric.com

Schneider
Electric

The information provided in this documentation contains general descriptions and/or technical characteristics of the performance of the products contained herein. This documentation is not intended as a substitute for and is not to be used for determining suitability or reliability of these products for specific user applications. It is the duty of any such user or integrator to perform the appropriate and complete risk analysis, evaluation and testing of the products with respect to the relevant specific application or use thereof. Neither Schneider Electric nor any of its affiliates or subsidiaries shall be responsible or liable for misuse of the information contained herein. If you have any suggestions for improvements or amendments or have found errors in this publication, please notify us.

No part of this document may be reproduced in any form or by any means, electronic or mechanical, including photocopying, without express written permission of Schneider Electric.

All pertinent state, regional, and local safety regulations must be observed when installing and using this product. For reasons of safety and to help ensure compliance with documented system data, only the manufacturer should perform repairs to components.

When devices are used for applications with technical safety requirements, the relevant instructions must be followed.

Failure to use Schneider Electric software or approved software with our hardware products may result in injury, harm, or improper operating results.

Failure to observe this information can result in injury or equipment damage.

© 2015 Schneider Electric. All rights reserved.

Table of Contents



	Safety Information	5
	About the Book.	9
Chapter 1	Pumping Functions	13
1.1	PumpPidStag: Pump Stage / Destage	15
	Description - PumpPidStag	16
	Function Block Description - PumpPidStag	23
	Structured Data Type Definitions - PumpPidStag	28
1.2	DevSwcPumpCtrl: Device Switching Pump Control	35
	Description - DevSwcPumpCtrl	36
	Function Block Description - DevSwcPumpCtrl	44
	Structured Data Type Definitions - DevSwcPumpCtrl	48
	Configuration Examples - DevSwcPumpCtrl	50
1.3	VsdCtrl: VSD Control	60
	Description - VsdCtrl	61
	Function Block Description - VsdCtrl	62
1.4	VsPumpCtrl: Variable Speed Pump Control	64
	Description - VsPumpCtrl	65
	Function Block Description - VsPumpCtrl	66
1.5	FsPumpCtrl: Fixed Speed Pump Control	69
	Description - FsPumpCtrl	70
	Function Block Description - FsPumpCtrl	71
1.6	CompSp: Setpoint Adaptation (Friction Loss Compensation)	73
	Description - CompSp	74
	Function Block Description - CompSp	77
	Structured Data Type Definitions - CompSp	79
1.7	CompSpFlow: Setpoint Adaptation by Using Flow Value (Friction Loss Compensation)	80
	Description - CompSpFlow	81
	Function Block Description - CompSpFlow	83
	Structured Data Type Definitions - CompSpFlow	85
1.8	CavtProt: Cavitation Protection	87
	Description - CavtProt	88
	Function Block Description - CavtProt	93
	Structured Data Type Definitions - CavtProt	95

1.9	PumpAvai: Pump Availability Status	97
	Description - PumpAvai	98
	Function Block Description - PumpAvai	99
1.10	VsdAvai: VSD Available Status	101
	Description - VsdAvai	102
	Function Block Description - VsdAvai	103
1.11	OpPrty: Operation Priority Device	105
	Description - OpPrty	106
	Function Block Description - OpPrty	108
	Structured Data Type Definitions - OpPrty	110
1.12	AuxPumpCtrl: Auxiliary Pump Control	111
	Description - AuxPumpCtrl	112
	Function Block Description - AuxPumpCtrl	116
	Structured Data Type Definitions - AuxPumpCtrl	119
1.13	PipeFill: Pipe Fill Control	121
	Description - PipeFill	122
	Function Block Description - PipeFill	126
	Structured Data Type Definitions - PipeFill	128
1.14	OpIntPump: Operator Interface for Pump Handling	131
	Description - OpIntPump	132
	Function Block Description - OpIntPump	135
	Structured Data Type Definitions - OpIntPump	140
1.15	OpIntAuxPump: Auxiliary Pump Operator Interface Function	145
	Description - OpIntAuxPump	146
	Function Block Description - OpIntAuxPump	149
	Structured Data Type Definitions - OpIntAuxPump	151
1.16	Common Structured Data Type Definitions	154
	Common Structured Data Type Definitions	154
	Glossary	165
	Index	167

Safety Information



Important Information

NOTICE

Read these instructions carefully, and look at the equipment to become familiar with the device before trying to install, operate, service, or maintain it. The following special messages may appear throughout this documentation or on the equipment to warn of potential hazards or to call attention to information that clarifies or simplifies a procedure.



The addition of this symbol to a “Danger” or “Warning” safety label indicates that an electrical hazard exists which will result in personal injury if the instructions are not followed.



This is the safety alert symbol. It is used to alert you to potential personal injury hazards. Obey all safety messages that follow this symbol to avoid possible injury or death.

DANGER

DANGER indicates a hazardous situation which, if not avoided, **will result in** death or serious injury.

WARNING

WARNING indicates a hazardous situation which, if not avoided, **could result in** death or serious injury.

CAUTION

CAUTION indicates a hazardous situation which, if not avoided, **could result in** minor or moderate injury.

NOTICE

NOTICE is used to address practices not related to physical injury.

PLEASE NOTE

Electrical equipment should be installed, operated, serviced, and maintained only by qualified personnel. No responsibility is assumed by Schneider Electric for any consequences arising out of the use of this material.

A qualified person is one who has skills and knowledge related to the construction and operation of electrical equipment and its installation, and has received safety training to recognize and avoid the hazards involved.

BEFORE YOU BEGIN

Do not use this product on machinery lacking effective point-of-operation guarding. Lack of effective point-of-operation guarding on a machine can result in serious injury to the operator of that machine.

WARNING

UNGUARDED EQUIPMENT

- Do not use this software and related automation equipment on equipment which does not have point-of-operation protection.
- Do not reach into machinery during operation.

Failure to follow these instructions can result in death, serious injury, or equipment damage.

This automation equipment and related software is used to control a variety of industrial processes. The type or model of automation equipment suitable for each application will vary depending on factors such as the control function required, degree of protection required, production methods, unusual conditions, government regulations, etc. In some applications, more than one processor may be required, as when backup redundancy is needed.

Only you, the user, machine builder or system integrator can be aware of all the conditions and factors present during setup, operation, and maintenance of the machine and, therefore, can determine the automation equipment and the related safeties and interlocks which can be properly used. When selecting automation and control equipment and related software for a particular application, you should refer to the applicable local and national standards and regulations. The National Safety Council's Accident Prevention Manual (nationally recognized in the United States of America) also provides much useful information.

In some applications, such as packaging machinery, additional operator protection such as point-of-operation guarding must be provided. This is necessary if the operator's hands and other parts of the body are free to enter the pinch points or other hazardous areas and serious injury can occur. Software products alone cannot protect an operator from injury. For this reason the software cannot be substituted for or take the place of point-of-operation protection.

Ensure that appropriate safeties and mechanical/electrical interlocks related to point-of-operation protection have been installed and are operational before placing the equipment into service. All interlocks and safeties related to point-of-operation protection must be coordinated with the related automation equipment and software programming.

NOTE: Coordination of safeties and mechanical/electrical interlocks for point-of-operation protection is outside the scope of the Function Block Library, System User Guide, or other implementation referenced in this documentation.

START-UP AND TEST

Before using electrical control and automation equipment for regular operation after installation, the system should be given a start-up test by qualified personnel to verify correct operation of the equipment. It is important that arrangements for such a check be made and that enough time is allowed to perform complete and satisfactory testing.

CAUTION

EQUIPMENT OPERATION HAZARD

- Verify that all installation and set up procedures have been completed.
- Before operational tests are performed, remove all blocks or other temporary holding means used for shipment from all component devices.
- Remove tools, meters, and debris from equipment.

Failure to follow these instructions can result in injury or equipment damage.

Follow all start-up tests recommended in the equipment documentation. Store all equipment documentation for future references.

Software testing must be done in both simulated and real environments.

Verify that the completed system is free from all short circuits and temporary grounds that are not installed according to local regulations (according to the National Electrical Code in the U.S.A, for instance). If high-potential voltage testing is necessary, follow recommendations in equipment documentation to prevent accidental equipment damage.

Before energizing equipment:

- Remove tools, meters, and debris from equipment.
- Close the equipment enclosure door.
- Remove all temporary grounds from incoming power lines.
- Perform all start-up tests recommended by the manufacturer.

OPERATION AND ADJUSTMENTS

The following precautions are from the NEMA Standards Publication ICS 7.1-1995 (English version prevails):

- Regardless of the care exercised in the design and manufacture of equipment or in the selection and ratings of components, there are hazards that can be encountered if such equipment is improperly operated.
- It is sometimes possible to misadjust the equipment and thus produce unsatisfactory or unsafe operation. Always use the manufacturer's instructions as a guide for functional adjustments. Personnel who have access to these adjustments should be familiar with the equipment manufacturer's instructions and the machinery used with the electrical equipment.
- Only those operational adjustments actually required by the operator should be accessible to the operator. Access to other controls should be restricted to prevent unauthorized changes in operating characteristics.

About the Book



At a Glance

Document Scope

This document describes the implementation of the Pumping functionality in SoMachine HVAC 2.0 or greater.

The function blocks described in this document are compatible with the Modicon M171 Performance Logic Controller and the Modicon M172 Performance Logic Controller.

This document is adapted to those individuals knowledgeable and experienced in pumping technologies.

Validity Note

This document has been created with the release of SoMachine HVAC 2.0.

Related Documents

Title of Documentation	Reference Number
SoMachine HVAC Programming Guide	EIO0000002036 (Eng)
SoMachine HVAC Software Quick Start	EIO0000002035 (Eng)

You can download these technical publications and other technical information from our website at <http://download.schneider-electric.com>

Product Related Information

WARNING

LOSS OF CONTROL

- The designer of any control scheme must consider the potential failure modes of control paths and, for certain critical control functions, provide a means to achieve a safe state during and after a path failure. Examples of critical control functions are emergency stop and overtravel stop, power outage and restart.
- Separate or redundant control paths must be provided for critical control functions.
- System control paths may include communication links. Consideration must be given to the implications of unanticipated transmission delays or failures of the link.
- Observe all accident prevention regulations and local safety guidelines.¹
- Each implementation of this equipment must be individually and thoroughly tested for proper operation before being placed into service.

Failure to follow these instructions can result in death, serious injury, or equipment damage.

¹ For additional information, refer to NEMA ICS 1.1 (latest edition), "Safety Guidelines for the Application, Installation, and Maintenance of Solid State Control" and to NEMA ICS 7.1 (latest edition), "Safety Standards for Construction and Guide for Selection, Installation and Operation of Adjustable-Speed Drive Systems" or their equivalent governing your particular location.

WARNING

UNINTENDED EQUIPMENT OPERATION

- Only use software approved by Schneider Electric for use with this equipment.
- Update your application program every time you change the physical hardware configuration.

Failure to follow these instructions can result in death, serious injury, or equipment damage.

Terminology Derived from Standards

The products described in the present document are designed to specific standards and the technical terms, terminology, symbols and the corresponding descriptions in this manual are intended to use the terms or definitions of those pertinent standards.

In the area of functional safety systems, drives and general automation, this may include, but is not limited to, terms such as *safety*, *safety function*, *safe state*, *fault*, *fault reset*, *malfunction*, *failure*, *error*, *error message*, *dangerous*, etc.

Among others, these standards include:

Standard	Description
EN 61131-2:2007	Programmable controllers, part 2: Equipment requirements and tests.
ISO 13849-1:2008	Safety of machinery: Safety related parts of control systems. General principles for design.
EN 61496-1:2013	Safety of machinery: Electro-sensitive protective equipment. Part 1: General requirements and tests.
ISO 12100:2010	Safety of machinery - General principles for design - Risk assessment and risk reduction
EN 60204-1:2006	Safety of machinery - Electrical equipment of machines - Part 1: General requirements
EN 1088:2008 ISO 14119:2013	Safety of machinery - Interlocking devices associated with guards - Principles for design and selection
ISO 13850:2006	Safety of machinery - Emergency stop - Principles for design
EN/IEC 62061:2005	Safety of machinery - Functional safety of safety-related electrical, electronic, and electronic programmable control systems
IEC 61508-1:2010	Functional safety of electrical/electronic/programmable electronic safety-related systems: General requirements.
IEC 61508-2:2010	Functional safety of electrical/electronic/programmable electronic safety-related systems: Requirements for electrical/electronic/programmable electronic safety-related systems.
IEC 61508-3:2010	Functional safety of electrical/electronic/programmable electronic safety-related systems: Software requirements.
IEC 61784-3:2008	Digital data communication for measurement and control: Functional safety field buses.
2006/42/EC	Machinery Directive
2004/108/EC	Electromagnetic Compatibility Directive
2006/95/EC	Low Voltage Directive

In addition, terms used in the present document may tangentially be used as they are derived from other standards such as:

Standard	Description
IEC 60034 series	Rotating electrical machines
IEC 61800 series	Adjustable speed electrical power drive systems
IEC 61158 series	Digital data communications for measurement and control – Fieldbus for use in industrial control systems

Finally, the term *zone of operation* may be used in conjunction with the description of specific hazards, and is defined as it is for a *hazard zone* or *danger zone* in the *EC Machinery Directive (EC/2006/42)* and *ISO 12100:2010*.

Chapter 1

Pumping Functions

Overview

This chapter describes the functions included in the Pumping Library.

This library contains function blocks that allow you to execute the following tasks:

- pump PID stage control ([see page 15](#))
- device switching control ([see page 35](#))
- FS pump control ([see page 71](#)), VS pump control ([see page 66](#)), VSD control ([see page 62](#))
- friction loss compensation basic ([see page 73](#)) and friction loss compensation by using the flow value to calculate an adjusted setpoint ([see page 74](#))
- cavitation protection ([see page 87](#))
- pump availability status verification ([see page 97](#)) and VSD availability status verification ([see page 101](#))
- detection of the device priority ([see page 105](#))
- auxiliary pump control ([see page 111](#))
- pipe fill control ([see page 121](#))
- control by operator interface ([see page 131](#))
- auxiliary pump control by operator interface ([see page 149](#))

What Is in This Chapter?

This chapter contains the following sections:

Section	Topic	Page
1.1	PumpPidStag: Pump Stage / Destage	15
1.2	DevSwcPumpCtrl: Device Switching Pump Control	35
1.3	VsdCtrl: VSD Control	60
1.4	VsPumpCtrl: Variable Speed Pump Control	64
1.5	FsPumpCtrl: Fixed Speed Pump Control	69
1.6	CompSp: Setpoint Adaptation (Friction Loss Compensation)	73
1.7	CompSpFlow: Setpoint Adaptation by Using Flow Value (Friction Loss Compensation)	80
1.8	CavtProt: Cavitation Protection	87
1.9	PumpAvai: Pump Availability Status	97
1.10	VsdAvai: VSD Available Status	101
1.11	OpPrty: Operation Priority Device	105
1.12	AuxPumpCtrl: Auxiliary Pump Control	111
1.13	PipeFill: Pipe Fill Control	121

Section	Topic	Page
1.14	OpIntPump: Operator Interface for Pump Handling	131
1.15	OpIntAuxPump: Auxiliary Pump Operator Interface Function	145
1.16	Common Structured Data Type Definitions	154

Section 1.1

PumpPidStag: Pump Stage / Destage

Overview

This section describes the `PumpPidStag` function block that consists of a PID function and a stage / destage pumping management.

It executes two main tasks to help to maintain a constant pressure in a water distribution network:

- The PID function is used to generate a PID control value (called the control value throughout this document). This value is used for the speed reference for the VSDs.
- The stage function is used to generate a stage value for the pumps. This stage value indicates whether an additional pump has to be switched on or a running pump has to be switched off.

NOTE: This function block is designed to be used in conjunction with other function blocks of the Pumping Library.

What Is in This Section?

This section contains the following topics:

Topic	Page
Description - <code>PumpPidStag</code>	16
Function Block Description - <code>PumpPidStag</code>	23
Structured Data Type Definitions - <code>PumpPidStag</code>	28

Description - PumpPidStag

Overview

The PumpPidStag function block consists of a PID control function and a stage / destage function to execute the following main tasks:

- Generating a PID control value with the PID control function. This value is used for the speed reference for the VSDs.
- Generating a pump stage value with the stage function. The stage value indicates the demand of the number of pumps that is needed to maintain a constant pressure in a water distribution network. The stage value calculation is based either on pressure values (pressure, pressure setpoint influenced by other functions) or on the flow in the network. Both stage solutions use the control value as a speed reference for the VSDs.

PID Control Function

The PID control function of the PumpPidStag function block is used to generate a control value. This value is used for the speed reference for the VSDs and the stage function.

To achieve this, the PID control function of the PumpPidStag function block executes the following tasks:

- Generates a control PID control value in the range of 0...100% with the PID control function. This value is used for the speed reference for the VSDs.
- Limits the integral (I) part of the control as follows:
 $Imax = 100\% - P$ (proportional) part value if P = positive.
This limitation of the PID control value leads to a saturation and helps to avoid long reaction times.
- Limits the I-part incremental to maximal increment = `stPidInit.rMaxErrForInt`. If the calculated increment is greater than `stPidInit.rMaxErrForInt`, then the value configured for this parameter is used as the incremental value for the I-part calculation. This function helps to limit the gradient of the I curve.
- Defines a dead band value for the error value e to help to reduce the frequency of switching the VSDs and thus to help limit wear. The dead band value reduces oscillation of the control value that is caused by disturbances of the discharge pressure. Oscillation of the control value by reaching a limit leads to superfluous switching actions.
- Accepts a setpoint that has been entered manually (with the input variable `i_rManSp`) if the PID control function is running in manual operating mode (`stOpMode.xPidMan = TRUE (1)`). This allows you to run the system with a high pressure in an exceptional situation, for example, to extinguish a fire.
- Verifies specific initialization data.
- Switches off the derivative part (D) if the PID control function is running in manual operating mode (`stOpMode.xPidMan = TRUE (1)`).
- Reinitializes the output and process variables to the default values if a reset is executed.
- Reinitializes the I part of the PID if a stop command is executed.
- Generates status bits (reporting the status) for the different modes and status situations.

Stage Function (Based on Pressure)

The stage function based on the control value is enabled by setting the input pin `i_eStage` to the constant value `Stage`.

This function calculates the number of pumps that is needed to maintain a constant pressure in the water distribution network based on the PID control value and a two-level control function (hysteresis-function). When the PID control value exceeds a limit, the stage value is increased or decreased.

The number of pumps is increased or decreased sequentially by using delay timers to avoid a high switching frequency and to allow the requested operation to be executed before the next operation is requested.

The delay principle works if one or more pumps are running and the PID parameters are adjusted correctly. However, up to the starting point of the first pump, the system has a delay, which can cause a fall below the pressure value under the tolerance range. To help avoid that, the function starts the first pump (stage value = 1) with the help of a deviation limit in percent (%). If the pressure value falls below this limit, the first pump is started (the stage value is set to the value 1).

Increase / decrease demand limits:

Stage limits for the control value of the PID controller

Limit	Description
<code>stStagInit.rLimStagPlus</code>	plus stage limit (0...100%)
<code>stStagInit.rLimStagMnus</code>	minus stage limit (0...100%)

The detection of the limit undershooting of the PID control value which is used to switch-off the last running pump is done by a dedicated PID control limit. This value should be lower than the stage minus limit value.

Limit	Description
<code>stStagInitCl.rLimPump1SwcOff</code>	control value limit pump 1 switch-off

As soon as the control value is beyond outside of these limits, the respective delay time is started. This delay time has to elapse before a switching process is executed. No switching processes are executed if the control value is between the 2 limit values (principle of a two-level PID controller).

Increase / decrease demand limits:

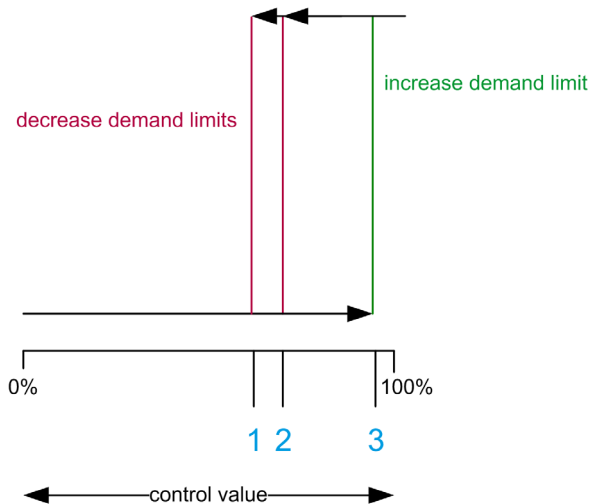

- 1 limit for decreasing stage value, if stage value = 1 (`stStagInit.rLimPump1SwcOff`)
- 2 limit for decreasing stage value, if stage value > 1 (`stStagInit.rLimStagMnus`)
- 3 limit for increasing stage value (`stStagInit.rLimStagPlus`)

This principle allows running the pumps in an energy efficient speed range (working range).

Exceeding the increase demand limit:

The switch-on delay timer (`stStagInit.tDlyStagPlus`) is started as soon as the control value exceeds the plus stage limit (`stStagInit.rLimStagPlus`).

After the switch-on delay time has elapsed, the stage value is increased by 1 until the `stStagInit.siStagPumpMax` value is reached. With this switching procedure, the switch-on delay timer (`stStagInit.tDlyStagPlus`) is re-started if the PID control value still exceeds the plus stage limit (`stStagInit.rLimStagPlus`).

As soon as the PID control value falls below the plus stage limit (`stStagInit.rLimStagPlus`), the switch-on delay timer (`stStagInit.tDlyStagPlus`) executes a reset.

Increase demand limit exceeded

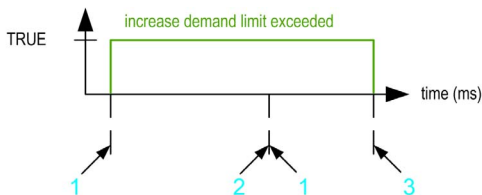

- 1 start switch-on delay timer (`stStagInit.tDlyStagPlus`)
- 2 switch-on delay time elapsed and stage value increased by 1
- 3 reset switch-on delay timer (`stStagInit.tDlyStagPlus`)

Falling below the decrease demand limit:

The switch-off delay timer (`stStagInit.tDlyStagMnus`) is started as soon as the PID control value falls below the minus stage limit (`stStagInit.rLimStagMnus`).

After the switch-off delay time has elapsed, the stage value is decreased by 1 until the value reaches zero. With this switching procedure, the switch-off delay timer (`stStagInit.tDlyStagMnus`) is re-started, if the PID control value is still inferior to the following minus stage limits:

- `stStagInit.rLimStagMnus` and the stage value is > 1 or
- `stStagInit.rLimPump1SwcOff` and the stage value is 1

As soon as the PID control value exceeds the minus stage limit (`stStagInit.rLimStagMnus`, respectively `stStagInit.rLimPump1SwcOff`), the switch-off delay timer executes a reset.

Decrease demand limit undershot

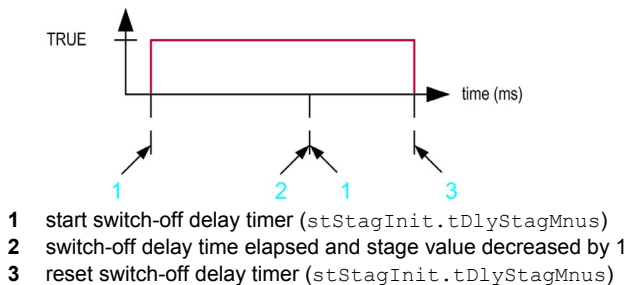

Extended Stage Function (Based on Flow and Pressure)

The extended stage function based on flow and pressure is enabled by setting the input pin `i_eStage` to the constant `Flow`.

NOTE: A flow meter is required in your system to use this function.

This function calculates the number of pumps that is needed to maintain a constant pressure in the water distribution network based on the PID control value and on the flow.

If the flow value becomes unavailable during operation, the application automatically activates the stage function using the calculated PID control value of the PID controller and the pressure value. In this case, the recording of the external value detects an error and the stage functions set a corresponding status flag (`stPidStagSta.xEmgyStagMode`), and the system continues operation.

Prerequisite

The flow value cannot be used to start the first pump. Due to this, the first pump is started if the PID control value exceeds the first pump switch-on limit (`stFlowStagInit.rCtrlValPump1OnLim`). After a delay time has elapsed (`stFlowStagInit.tDelTimeSwcOn`), the first pump is started. As soon as the first pump is running, the extended stage function, based on flow, is available.

Starting the first pump

If the PID control value exceeds the limit defined with the parameter `stFlowStagInit.rCtrlValPump1OnLim`, then the delay time (`stFlowStagInit.tDelTimeSwcOn`) is started. After the delay time has elapsed, the first pump is started. With the start of the first pump, the flow value is rising.

The figure shows the switch-on condition for the first pump:

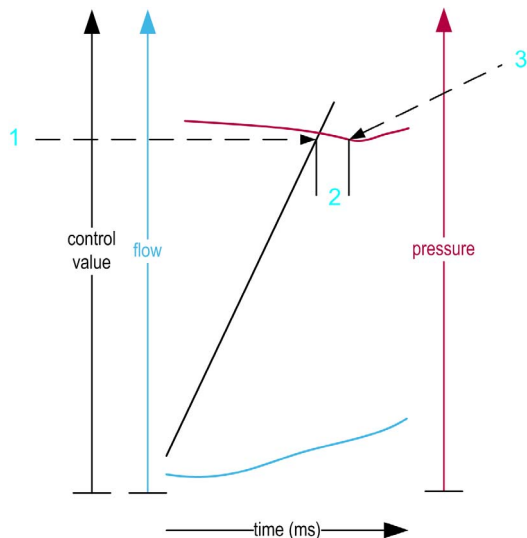

- 1 PID control limit (`stFlowStagInit.rCtrlValPump1OnLim`) to start the first pump
- 2 switch-on delay time (`stFlowStagInit.tDelTimeSwcOn`)
- 3 start of the first pump

Switching the pumps according to the flow

If the extended stage function is active, the pumps are switched according to the flow limits defined for a maximum of 8 pumps. Since there is no delay time used in this procedure, the reaction times are greater than for the stage function based on pressure. This kind of staging immediately stops the pumps in case of a pipe-burst, except the last pump.

Staging / destaging according to the flow value:

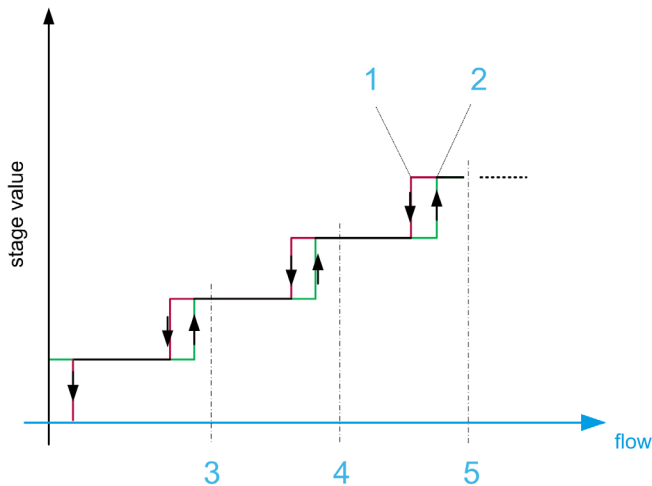

- 1 stage flow limit (stop) for a pump (here pump number 4)
- 2 stage flow limit (start) for a pump (here pump number 4)
- 3 maximum flow of one pump
- 4 maximum flow of two pumps
- 5 maximum flow of three pumps

Avoiding a deadlock by using the following principals

The speed of the running pump(s) must be reducible to a speed that is under the switch-off limit of the last pump to allow stopping the last fixed speed pump (FS pump), if FS pumps are used. Therefore, you must consider the minimum speed that is configured for the drive(s) to make sure that it is not greater than the switch-off limit.

Further, you need to have a minimum of 2 variable speed drives (VSDs) in the combination of variable speed pumps (VS pumps) and fixed speed pumps (FS pumps).

If the number of operational VSDs is reduced to under the 2 VSD minimum required by the stage flow method, the function `DevSwcPumpCtrl` sets the state of the output pin `q_xFlowStageEn` to FALSE. This pin is linked to the input pin `i_xFlowStageEn` of the `PumpPidStage` function. In this case, the stage function is switched to the method based on the pressure as opposed to the flow.

NOTE: Be sure that the stage function based upon pressure has been configured with the appropriate parameters to support this case.

Switching off the last pump:

Before switching off the last pump, there must be reserve pressure in the expansion tank to compensate for the delayed starting of the first pump when coming out of sleep mode. Therefore, it is not the simple matter of switching off the last pump when the flow value reaches a specific setpoint. When the flow reaches the lower limit, a new setpoint is calculated to create the required reserve pressure that is to be maintained by the auxiliary pump while in sleep mode. This new setpoint is the sum of the pressure reference value (i_rSp) plus a pressure increment that is configurable via `stFlowStagInit.rPresIncPump1SwcOff`. This new value is then used as the pressure lower limit for the purpose of switching off the last pump.

This incremental pressure value used to calculate the sleep mode pressure described above must be within the configured pressure limits of the auxiliary pump. A valid working value for the increment would correspond to the average of the limits of the auxiliary pump ($(rPresAuxLimOn + rPresAuxLimOff) / 2$).

In addition, once the sleep mode pressure has been reached, a switch off delay timer is started before the last running pump is switched off. The delay timer is used to maintain a minimum runtime of the pump and minimum time between sleep mode intervals.

Switching off the last pump:

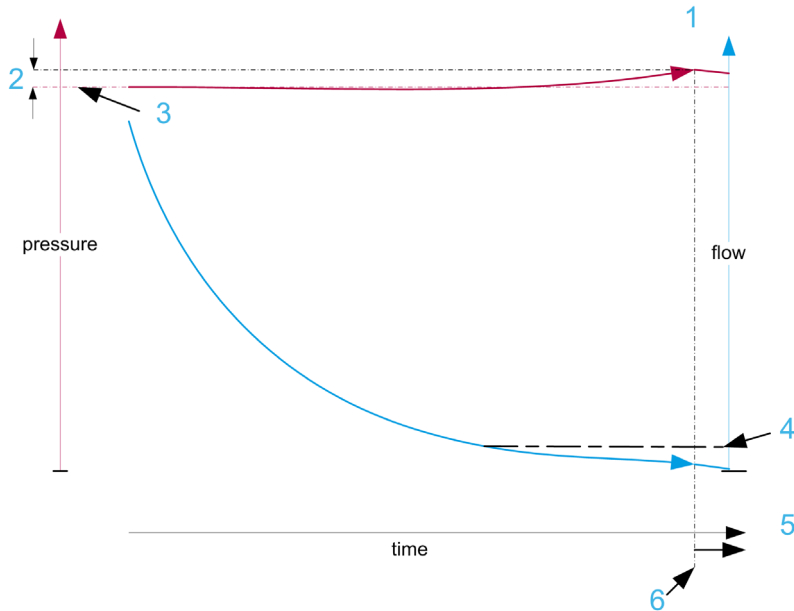

- 1 pressure for switching of the last pump (`stFlowStagInit.rPresIncPump1SwcOff (2) + i_rSp (3)`)
- 2 configured pressure increment (`stFlowStagInit.rPresIncPump1SwcOff (2)`)
- 3 pressure reference value (i_rSp)
- 4 switch-off demand based on flow for the last pump (`stFlowStagInit.rMinFlowLimPump1Off`)
- 5 sleep mode is executed
- 6 last pump is switched-off

Function Block Description - PumpPidStag

Pin Diagram

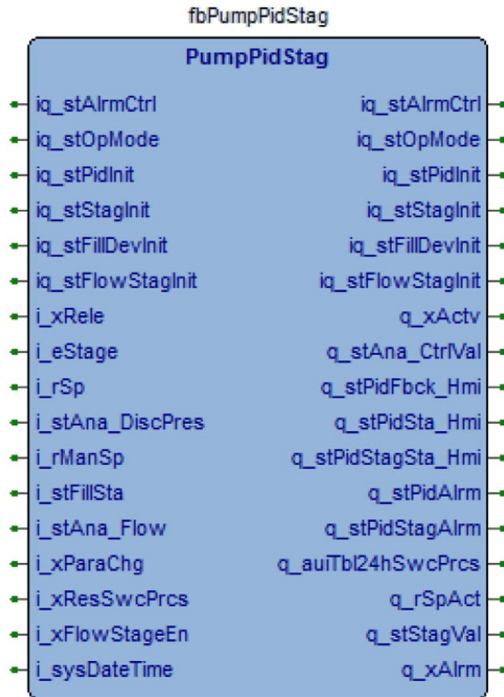

Brief Description

The PumpPidStag function block consists of a PID function and a stage / destage pumping management function to execute the following tasks:

- generating a PID control value. This value is used for the speed reference for the VSDs.
- generating a pump demand stage value

I/O Variables Description

The table describes the input/output variables of the function block:

Input/Output	Data Type	Description
iq_stAlarmCtrl	stAlarmCtrl	Structure used for alarm handling. Refer to the structured data type description (see page 154) .
iq_stOpMode	stOpMode	Determines the operating modes. If the element <code>xAuto</code> of the <code>stOpMode</code> structured data type is set to TRUE, the function block executes its tasks automatically. With another status of this element, the outputs of this function block are set to their defined fallback (default) states. If the element <code>xPidMan</code> of this structured data type is set to TRUE, it is allowed to enter a user-defined setpoint manually. If the element <code>xFill</code> of this structured data type is set to TRUE, the PID function is disabled if the pipe fill function is running in sequence 1. In this case the <code>iq_stFillDevInit</code> parameters are used to set the output pins <code>q_stAna_CtrlVal.stAnaVal</code> and <code>q_stStagVal.siStag</code> . Refer to the structured data type description (see page 155) .
iq_stPidInit	stPidInit	Structure used for initialization data of the PID control function. Refer to the structured data type description (see page 28) .
iq_stStagInit	stStagInit	Structure used for initialization data of the stage function based on pressure. Refer to the structured data type description (see page 29) .
iq_stFillDevInit	stFillDevInit	Structure used for initialization data if sequence 1 of the pipe fill mode is active. Refer to the structured data type description (see page 30) .
iq_stFlowStagInit	stFlowStagInit	Structure used for initialization data of the stage function based on flow. Refer to the structured data type description (see page 30) .

The table describes the input variables to the function block:

Input	Data Type	Description
i_xRele	BOOL	Activate (TRUE) or stops (FALSE) the execution of the function block.
i_eStage	eStage	Activates the stage function and which method is selected: <ul style="list-style-type: none"> ● i_eStage = Off: stage function deactivated (default value) ● i_eStage = Stage: stage method by using only the pressure to generate the stage value is activated ● i_eStage = Flow: stage method by using additionally the flow value is activated
i_rSp	REAL	Contains the user-defined pressure setpoint that can be adapted by other functions (compensation functions (see page 74) or the cavitation protection function (see page 88)).
i_stAna_DiscPres	stAna	Contains the discharge pressure value and its status. Refer to the stAna structured data type description (see page 156).
i_rManSp	REAL	Contains the pressure setpoint that has been entered manually by the operator. This parameter is only taken into account if the pumping application is operated in PID manual mode (stOpMode.xPidMan = TRUE).
i_stFillSta	stFillStat	Structure that indicates the states of the pipe fill function. The PID control and stage functions of the PumpPidStag function block are disabled if the pipe fill function is running in sequence 1 (xSequ1 = TRUE) because, in this case, a defined number of pumps is used at a fixed speed (see page 123). If the pipe fill function has set the flag in the stFillSta structure to xFillOK, or if it is running in sequence 2 (xSequ2 = TRUE), then the PID control, if released, enables the stage functions of the PumpPidStag function block. Otherwise the PID function including the stage function is disabled.
i_stAna_Flow	stAna	Contains the flow value and its status. This input is only considered if the stage function based on flow is activated (input i_eStage = Flow or i_eStage = 2). Refer to the structured data type description (see page 156).
i_xParaChg	BOOL	When TRUE, the new parameter values are used (mapping into internal variables after a valid verification).
i_xResSwcPrCs	BOOL	When TRUE, the counter of switching cycles (output q_auiTb124hSwcPrCs) is reset to 0.

Input	Data Type	Description
i_xFlowStageEn	BOOL	When TRUE, at least 2 VSDs and corresponding VS pumps are available. This means that the stage function based on flow is available. When FALSE, an insufficient number of VSDs / VS pumps is available. The stage function based on pressure is applied. The stage function based on flow is not allowed.
i_sysDateTime	DT	This input should be linked to the controller system variable TypeDateTime, if available.

The table describes the output variables from the function block:

Output	Data Type	Description
q_xActv	BOOL	When TRUE, indicates that the PID function is active.
q_stAna_CtrlVal	stAna	Structure that indicates the PID control value and the state of this value. Refer to the structured data type description (see page 163).
q_stPidFbck_Hmi	stPidFbck	Structure that is used to display the values of the different PID components on the HMI. Refer to the structured data type description (see page 32).
q_stPidSta_Hmi	stPidSta	Structure that is used to display the status of the PID function on the HMI. Refer to the structured data type description (see page 32).
q_stPidStagSta_Hmi	stPidStagSta	Structure that is used to display the status of the stage function on the HMI. Refer to the structured data type description (see page 33).
q_stPidAlrm	stPidAlrm	Structure that indicates the alarm states detected in the PID function of the PumpPidStag function block. Refer to the structured data type description of alarms (see page 33).
q_stPidStagAlrm	stStagAlrm	Structure that indicates the alarm states detected in the stage function of the PumpPidStag function block. Refer to the structured data type description of alarms (see page 34).

Output	Data Type	Description
q_auiTbl24hSwcPrs	ARRAY [0..23] of UINT	<p>Contains counters indicating the number of switching cycles (pump on/off) per hour. The hour value (24-hour value) of the controller is used as a pointer to this 24-hour array. The 24-hour array is used as a circular buffer.</p> <p>NOTE: For example, after 48 hours, one hour value contains the switching value of 2 days.</p> <p>You can use this value to optimize the configuration of your system to reduce the number of switching cycles while maintaining the user-defined pressure.</p> <p>NOTE: This function is reserved to controllers that maintain a system clock.</p>
q_rSpAct	REAL	Contains the present setpoint to display on the HMI.
q_stStagVal	stStagVal	Structure that indicates the number of pumps needed (demand) to maintain the user-defined pressure level. Refer to the structured data type description (see page 157).
q_xAlrm	BOOL	Alarm flag.

Structured Data Type Definitions - PumpPidStag

Overview

Structured data types serve as the major input and output data carriers between different function blocks, configuration, and parameterization data.

The following section lists the names of structures (data types) that are used in this function block, followed by a table that describes the elements of structure.

NOTE: For the structured data types that are used from this function block and others, refer to the Common Structured Data Type Definitions chapter ([see page 154](#)).

Structure: stPidInit

The stPidInit structured data type contains the initialization data for the PID function of the PumpPidStag function block.

Element of stPidInit	Data Type	Description
rKp	REAL	Defines the proportional gain constant (Kp) for the proportional part (P) of the PID function. Default value: 0.001
rTn	REAL	Defines the integral time (Tn) for the integral part (I) of the PID function. Default value: 1000 ms
rTv	REAL	Defines the derivative time (Tv) for the derivative part (D) of the PID function. Default value: 0.0 ms
rTd	REAL	Defines the derivative damping time (Td) for the derivative part (D) of the PID function. Default value: 0.0 ms
rDbnd	REAL	Defines the value of the dead band for the error value (e) to help to reduce the frequency of switching the VSDs, and thus to help limit wear. A switching process is only initiated if the deviation from the error value (e) exceeds the value defined with this parameter. Default value: 0.0001
rLowLim	REAL	Defines the minimum output limit for the PID control value (in percent). Default value: 0.0
rHighLim	REAL	Defines the maximum output limit for the PID control value (in percent). Default value: 100.0

Element of <code>stPidInit</code>	Data Type	Description
<code>rMaxErrForInt</code>	REAL	Defines the maximum incremental value for the calculation of the I part. If the incremental value is greater than the value defined with this parameter, then the value of this parameter is used as incremental value. This function helps to limit the gradient of the I curve. If the value for this parameter is ≤ 0 , a detected alarm is indicated with the parameter <code>stPidAlrm.xMaxErrForIntPara</code> . Default value: 50.0
<code>udiSwcOverDly</code>	UDINT	Defines the delay time in milliseconds for suppression of the D term in case it is switched from automatic setpoint to manual setpoint and vice versa. Default value: 100000.0

NOTE: The elements of the instance of the structured data type are set to the default values listed above if no other value is assigned.

Structure: `stStagInit`

The `stStagInit` structured data type contains the initialization data for the stage function of the `PumpPidStag` function block. The structured data type is embedded in the structured data type `stInitApp`.

Element of <code>stStagInit</code>	Data Type	Description
<code>siStagPumpMax</code>	SINT	Defines the total number of VS and FS pumps for the stage function.
<code>rPresIncPump1SwcOff</code>	REAL	Defines the increment that is added to the pressure setpoint value to calculate a pressure limit to switch off the last pump that is running (see page 19). The calculated value consists of the pressure reference value (<code>i_rSp</code>) plus this incremental value to reach a pressure level that corresponds to the average value of the working range of the auxiliary pump. The increase of the pressure increases the quantity of water in the expansion tank. This procedure helps prevent an early restart of the pumps.
<code>rLimStagPlus</code>	REAL	Defines the limit to increment the stage value (0...100%) that is the demand to switch a pump to the ON state.
<code>rLimStagMnus</code>	REAL	Defines the limit to decrease the stage value (0...100%) that is the demand to switch a pump to the OFF state.
<code>tDlyStagPlus</code>	UDINT	Defines the delay time in milliseconds that has to elapse after the <code>rLimStagPlus</code> has been reached before a pump is switched on.

Element of <code>stStagInit</code>	Data Type	Description
<code>tDlyStagMnus</code>	UDINT	Defines the delay time in milliseconds that has to elapse after the <code>rLimStagMnus</code> has been reached before a pump is switched off.
<code>rPercDeriv</code>	REAL	Percent deviation value of the discharge pressure from the setpoint to start the first pump.

NOTE: The elements of the instance of the structured data type are set to the default values (0 or FALSE) assigned by the controller on system startup.

Structure: `stFillDevInit`

The `stFillDevInit` structured data type contains the initialization data for the `PumpPidStag` function block when sequence 1 of the pipe fill mode is active (`stOpMode.xFill = TRUE` and `stFillStat.xSeq1 = TRUE`).

Element of <code>stFillDevInit</code>	Data Type	Description
<code>rCtrlVal</code>	REAL	Defines the output limit for the PID control value (in percent). Default value: 50.0%
<code>byNoPump</code>	BYTE	Defines the number of pumps that have to run if sequence 1 of the pipe fill mode is active. Default value: 2

NOTE: The elements of the structure are set to the default values listed above.

Structure: `stFlowStagInit`

The `stFlowStagInit` structured data type contains the initialization data for the stage function of the `PumpPidStag` function block considering the flow value ([see page 19](#)).

Element of <code>stFlowStagInit</code>	Data Type	Description
<code>siStagPumpMax</code>	SINT	Defines the total number of VS and FS pumps for the stage function based on flow.
<code>rMinFlowLimPump1Off</code>	REAL	Defines the minimum flow that has to be available to switch off the last pump (pump 1).
<code>rPresIncPump1SwcOff</code>	REAL	Defines the pressure that has to be available to switch off pump 1. This value consists of the pressure reference value (<code>i_rSp</code>) plus an additional incremental value to reach a pressure level that corresponds to the average value of the working range of the auxiliary pump.

Element of stFlowStagInit	Data Type	Description
rCtrlValPump1OnLim	REAL	Defines the minimum limit of the PID control value that has to be available to switch on pump 1. At least 1 pump has to run to generate a flow value. Only then you can use the stage function based on flow.
tDelTimeSwcOn	UDINT	Defines the delay time in milliseconds that has to expire before the first pump is switched on.
tDelTimeSwcOFF	UDINT	Defines a minimum time in milliseconds the first pump has to be running before it can be switched off again. It is the minimum runtime between 2 sleep mode intervals.
rFlowValPump2OnLim	REAL	Defines the flow value to increase the demand of number of pumps to 2.
rFlowValPump2OffLim	REAL	Defines the flow value to decrease the demand of number of pumps from 2 to 1.
rFlowValPump3OnLim	REAL	Defines the flow value to increase the demand of number of pumps to 3.
rFlowValPump3OffLim	REAL	Defines the flow value to decrease the demand of number of pumps from 3 to 2.
rFlowValPump4OnLim	REAL	Defines the flow value to increase the demand of number of pumps to 4.
rFlowValPump4OffLim	REAL	Defines the flow value to decrease the demand of number of pumps from 4 to 3.
rFlowValPump5OnLim	REAL	Defines the flow value to increase the demand of number of pumps to 5.
rFlowValPump5OffLim	REAL	Defines the flow value to decrease the demand of number of pumps from 5 to 4.
rFlowValPump6OnLim	REAL	Defines the flow value to increase the demand of number of pumps to 6.
rFlowValPump6OffLim	REAL	Defines the flow value to decrease the demand of number of pumps from 6 to 5.
rFlowValPump7OnLim	REAL	Defines the flow value to increase the demand of number of pumps to 7.
rFlowValPump7OffLim	REAL	Defines the flow value to decrease the demand of number of pumps from 7 to 6.
rFlowValPump8OnLim	REAL	Defines the flow value to increase the demand of number of pumps to 8.
rFlowValPump8OffLim	REAL	Defines the flow value to decrease the demand of number of pumps from 8 to 7.

NOTE: The elements of the instance of the structured data type are set to the default values (0 or FALSE) assigned by the controller on system startup.

Structure: stPidFbck

The `stPidFbck` structured data type is used to indicate the values of the different components of the PID function on the HMI:

Element of <code>stPidFbck</code>	Data Type	Description
<code>rP_Part</code>	REAL	Indicates the value of the proportional part (P).
<code>rI_Part</code>	REAL	Indicates the value of the integral part (I).
<code>rD_Part</code>	REAL	Indicates the value of the differential part (D).
<code>xI_Part_Actv</code>	BOOL	When TRUE, indicates that the integral part (I) is active.
<code>xD_Part_Actv</code>	BOOL	When TRUE, indicates that the differential part (D) is active.

Structure: stPidSta

The `stPidSta` structured data type is used to indicate the status of the PID function on the HMI:

Element of <code>stPidSta</code>	Data Type	Description
<code>xErrLimActv</code>	BOOL	When TRUE, indicates that the maximum increment value of the I part of the PID control value calculation is exceeded (defined with the parameter <code>stPidInit.rMaxErrForInt</code>) and that the limitation of the increment value from the I part of the PID control value is active.
<code>xAntiWndoActv</code>	BOOL	When TRUE, indicates that the anti-windup process of the I part is active. TRUE = I part – P part > 100%
<code>xLowLimActv</code>	BOOL	When TRUE, indicates that the calculation of the I part of the calculation of the PID control value is less than the minimum output limit for the PID control value (defined with the parameter <code>stPidInit.RLowLim</code>). Then the limitation of the calculation of the I part of the calculation of the PID control value is active.
<code>xCtrlValHighLimActv</code>	BOOL	When TRUE, indicates that the high limit for the PID control value (defined with the parameter <code>rHighLim</code>) is exceeded and the limitation of the PID control value is active.
<code>xCtrlValLowLimActv</code>	BOOL	When TRUE, indicates that the low limit for the PID control value (defined with the parameter <code>rLowLim</code>) is undershot and the limitation of the PID control value is active.
<code>xResActv</code>	BOOL	Indicates that the PID function has executed a reset.
<code>xHoldActv</code>	BOOL	Indicates that the PID function is in stopped mode.
<code>xStopActv</code>	BOOL	Indicates that the PID function has been stopped.

Element of <code>stPidSta</code>	Data Type	Description
<code>xManActv</code>	BOOL	Indicates that the PID function is operated in manual mode, allowing to enter a setpoint via the HMI.
<code>xAutoActv</code>	BOOL	Indicates that the PID function is operated in automatic mode.
<code>xDBndActv</code>	BOOL	Indicates that a deviation has been suppressed. The PID control value is unchanged.
<code>xErrActv</code>	BOOL	Indicates that an error has been detected in the PID function.
<code>xParaChg</code>	BOOL	Indicates that the parameter values will be mapped in an internal memory, if the verification of the parameter was successful (reaction of the input <code>i_xParaChg</code>).

Structure: `stPidStagSta`

The `stPidStagSta` structured data type is used to indicate the status of the stage function on the HMI:

Element of <code>stPidStagSta</code>	Data Type	Description
<code>eStage_Mode</code>	enumeration <code>eStage</code>	Indicates whether a stage function is active and which method is selected: <ul style="list-style-type: none"> <code>eStage_Mode = Off</code> or <code>0</code>: stage function is deactivated <code>eStage_Mode = Stage</code> or <code>1</code>: stage method by using only the pressure to generate the stage value is active <code>eStage_Mode = Flow</code> or <code>2</code>: stage method by using additionally the flow value is active
<code>xEmgyStagMode</code>	BOOL	Indicates that the stage method based on flow is not executable and the stage method based on pressure is used instead.
<code>xSlpMode</code>	BOOL	Indicates that the booster pumping application is in sleep mode.

Structure: `stPidAlrm`

The `stPidAlrm` structured data type is used to indicate an alarm detected in the PID function:

Element of <code>stPidAlrm</code>	Data Type	Description
<code>xInvdLimPara</code>	BOOL	When TRUE, an invalid limit parameter has been detected.
<code>xInvdDeadBandPara</code>	BOOL	When TRUE, an invalid dead band limit parameter has been detected.
<code>xKpPara</code>	BOOL	When TRUE, an invalid Kp parameter has been detected.

Element of <code>stPidAlrm</code>	Data Type	Description
<code>xTnPara</code>	BOOL	When TRUE, an invalid Tn parameter has been detected.
<code>xTvPara</code>	BOOL	When TRUE, an invalid Tv parameter has been detected.
<code>xMaxErrForIntPara</code>	BOOL	When TRUE, an invalid maximum limit for the calculation of the I part has been detected.

Structure: `stPidStagAlrm`

The `stPidStagAlrm` structured data type is used to indicate a detected alarm in the stage function:

Element of <code>stPidStagAlrm</code>	Data Type	Description
<code>xFlowDataCheckAlrm</code>	BOOL	When TRUE, the flow value is no longer valid.
<code>xDeltaPres</code>	BOOL	Delta pressure not available.
<code>xOpModeFault</code>	BOOL	Incorrect operation mode.
<code>xParFlt</code>	BOOL	Incorrect parameter.

Section 1.2

DevSwcPumpCtrl: Device Switching Pump Control

Overview

This section describes the `DevSwcPumpCtrl` function block for switching management of variable speed drives (VSD), variable speed pumps (VS pumps), and fixed speed pumps (FS pumps). The function supports up to 8 pumps. These 8 pumps can be any mix of VS pumps or FS pumps assuming at least one pump is a VS pump.

NOTE: This function block is designed to be used in conjunction with other function blocks of this library. The function block architecture helps simplify programming the booster pumping functionality.

What Is in This Section?

This section contains the following topics:

Topic	Page
Description - <code>DevSwcPumpCtrl</code>	36
Function Block Description - <code>DevSwcPumpCtrl</code>	44
Structured Data Type Definitions - <code>DevSwcPumpCtrl</code>	48
Configuration Examples - <code>DevSwcPumpCtrl</code>	50

Description - DevSwcPumpCtrl

Overview

The `DevSwcPumpCtrl` function block switches the variable speed drives (VSD), variable speed (VS) pumps and fixed speed (FS) pumps according to different criteria in order to maintain a constant pressure in a water distribution network.

It executes the following main tasks:

- Switching a maximum of 4 VSDs into run or stop state in flexible operational mode.
- Switching a maximum of 8 VSDs into run or stop state in fixed link operational mode (with or without bypass).
- Establishing a permanent or flexible link between VSDs and VS pumps.
- Starting or stopping a maximum of 8 VS pumps and having them bypass the VSD, in case the VSD is unavailable and no FS pump is available as an alternative.
- Starting or stopping a maximum of 7 FS pumps.
- Verifying the availability of VSDs and VS pumps. In case there are not enough VSD/VS pumps for the flow staging method; it initiates the `PumpPidStag` function block to stop using the flow value as a basis for stage value calculation ([see page 19](#)) and to use only the pressure value ([see page 17](#)).

The `DevSwcPumpCtrl` function block considers the following criteria for switching the VSDs, VS pumps, and FS pumps:

- availability of the devices (VSD ([see page 102](#)), VS pumps, FS pumps ([see page 98](#)))
- demand of the stage value ([see page 16](#))
- priority of the devices (VSD, VS pumps, FS pumps ([see page 106](#)))

Prerequisite

The `DevSwcPumpCtrl` function block executes its tasks only if the following conditions apply:

- The pumping application is running in automatic mode.
The automatic mode is established by the structured data type `stOpMode` being set to `xAuto` (for more information refer to the chapter Common Structured Data Type Definitions ([see page 155](#))).

With another setting of this variable, the `DevSwcPumpCtrl` function block is disabled and the function block outputs are set to the default value (0 and FALSE).

- The alarm release bit `xAlrmRele` of the structured data type `stAlrmCtrl` ([see page 154](#)) is set to TRUE, indicating that no alarm has been detected in the pump group.

If the alarm release bit `xAlrmRele` is set to FALSE, the `DevSwcPumpCtrl` function block is disabled and the function block outputs are set to the default value (0 and FALSE).

Error Detection

According to the type of error the `DevSwcPumpCtrl` function block detects, it either issues an alarm or an alert. The actions that are executed differ for detected alarms and alerts.

Actions when an alarm ([see page 49](#)) has been detected in the pump group:

If	Then
an alarm has been detected in the pump group	the <code>DevSwcPumpCtrl</code> function block sets the corresponding alarm bit (<code>q_stSwcAlrm</code>) to TRUE indicating which type of alarm has been detected.
	the variable <code>stOpMode</code> is set to manual mode (<code>xMan</code>).
	the <code>DevSwcPumpCtrl</code> function block stops processing variables.
	the outputs of the <code>DevSwcPumpCtrl</code> function block are set to the default value (0 and FALSE).
	the alarm release bit <code>iq_stAlrmCtrl.xAlrmRele</code> is set to FALSE to indicate the detected alarm state to the other function blocks.

Actions when an alert has been detected in the pump group:

If	Then
an alert has been detected in the pump group	the <code>DevSwcPumpCtrl</code> function block sets the corresponding alert bit (<code>q_xNoVsPlusFs</code>) to TRUE indicating that the stage value is greater than the number of usable pumps.
	the function block continues operation.

Switching VSDs or Pumps According to the Availability of the Devices

If the pumping application is running in automatic mode, the `DevSwcPumpCtrl` function block verifies the state of the running VSDs, VS pumps, and FS pumps.

If one of these devices becomes unavailable, the `DevSwcPumpCtrl` function block starts another device of the same type, if available, or of a different type according to the following general rules:

If	Then
a VSD becomes unavailable and there is no other VSD available for replacement	an FS pump is used alternatively. If no FS pump is available, the VS pump that had been linked to the VSD can bypass the VSD (if the bypass option is enabled). If more than 1 VS pump is available, the function runs the VS pump contingent on priority conditions (see page 106). The link between the VSD and the VS pump is maintained as long as the VSD and the VS pump are operational.
a VS pump becomes unavailable and there is no other VS pump for replacement	an FS pump is used alternatively and the VSD that had been linked to the VS pump is switched into stop state.

Switching VSDs or Pumps According to the Stage Value

If the pumping application is running in automatic mode, the `DevSwcPumpCtrl` function block continuously receives input from the `PumpPidStag` function block (see page 23) via the `i_stStagVal` input value (see page 16). This input can initiate a switching procedure. Depending on the stage value from the `PumpPidStag` function block, it may be required to switch VSDs, VS pumps or FS pumps on or off considering the general rule (switching on VSDs and VS pumps first, then FS pumps) as shown in the following flowcharts.

Actions when the stage value increases and the `xFlexStart` flag is set to FALSE:

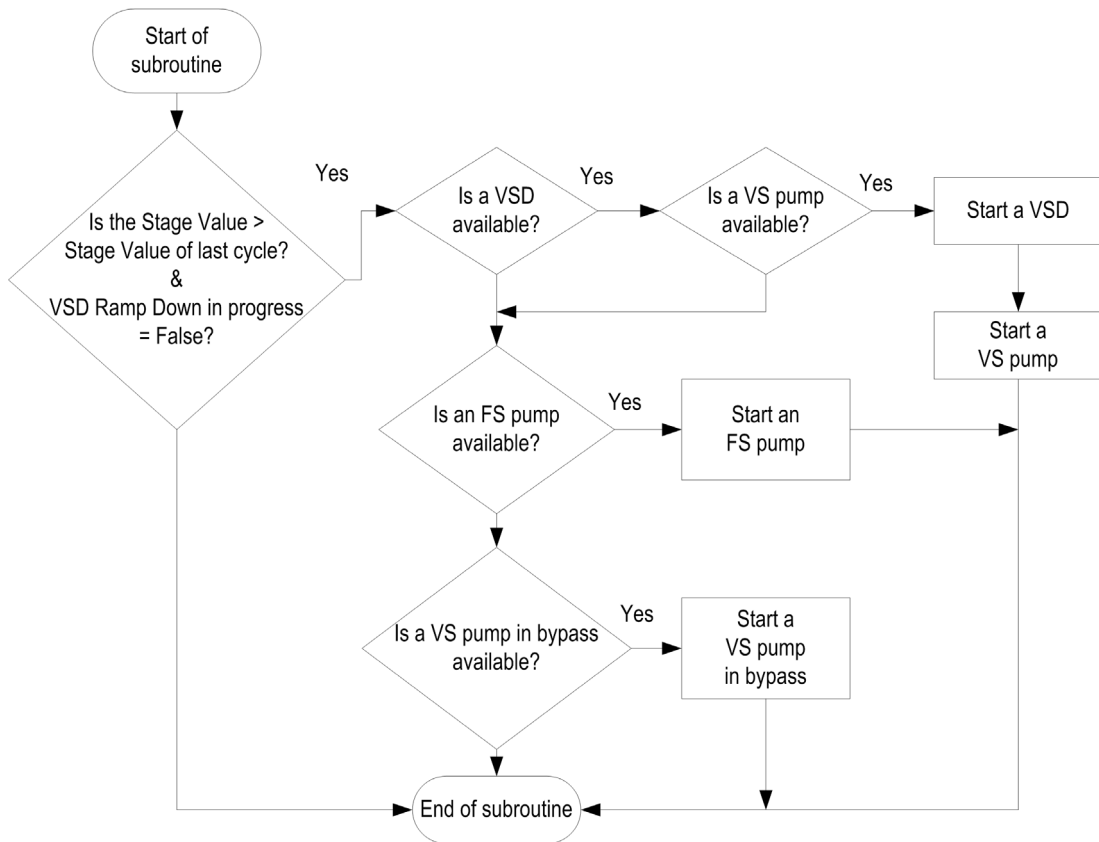

NOTE: The processes to start a VSD, a VS pump, or an FS pump, consider also the priority defined with the `OpPrty` function block ([see page 108](#)).

Actions when the stage value increases and the `xFlexStart` flag is set to TRUE:

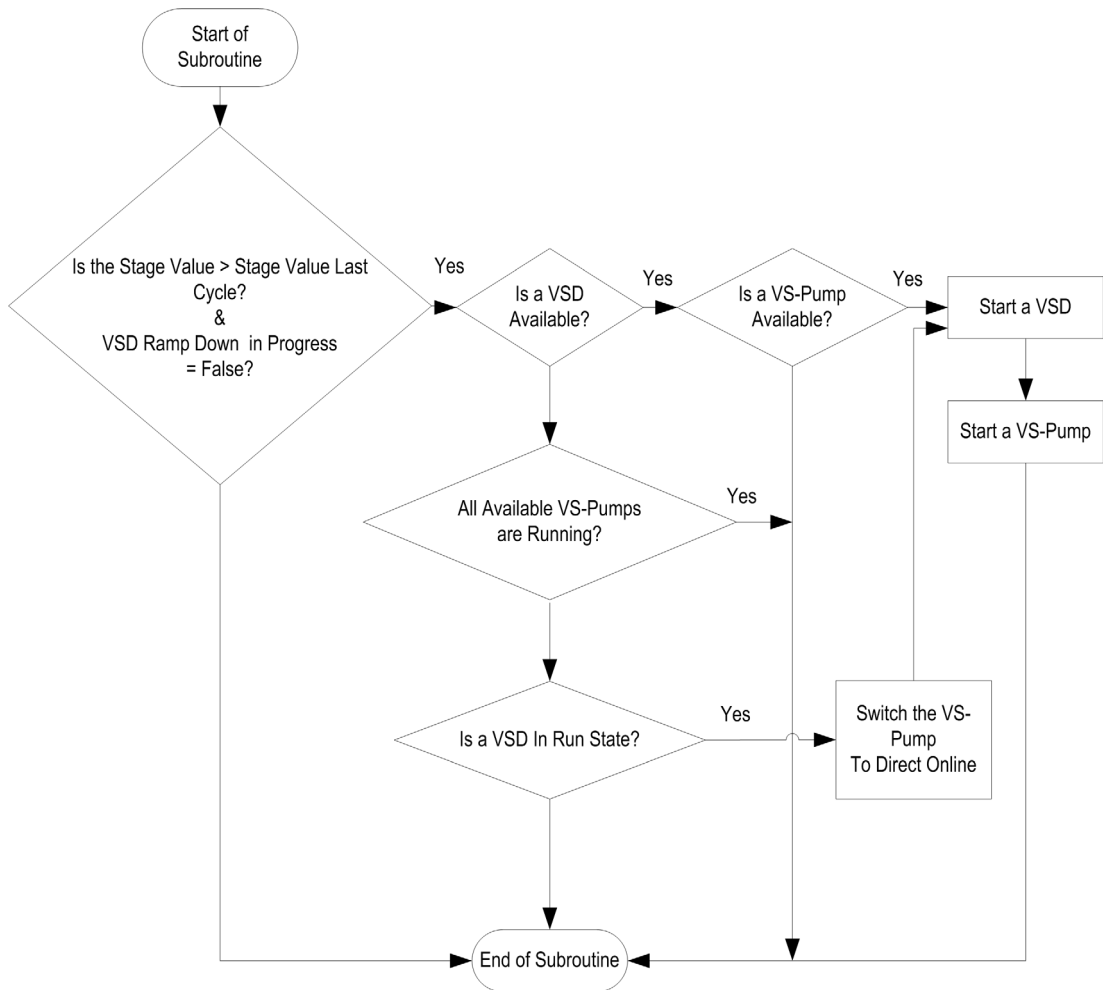

NOTE: The processes to start a VSD or a VS pump, consider also the priority defined with the `OpPrty` function block (see page 108).

Actions when the stage value decreases:

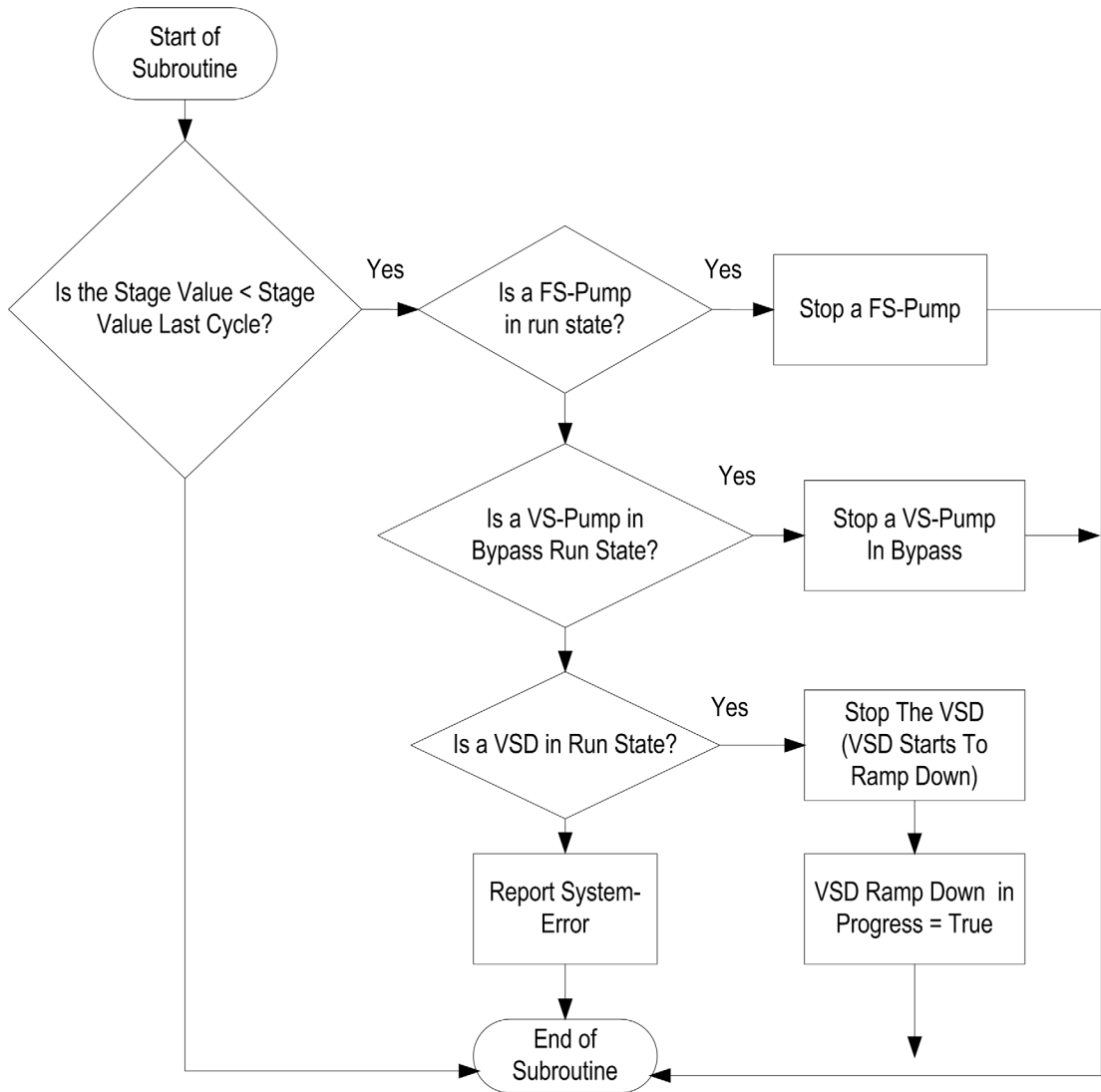

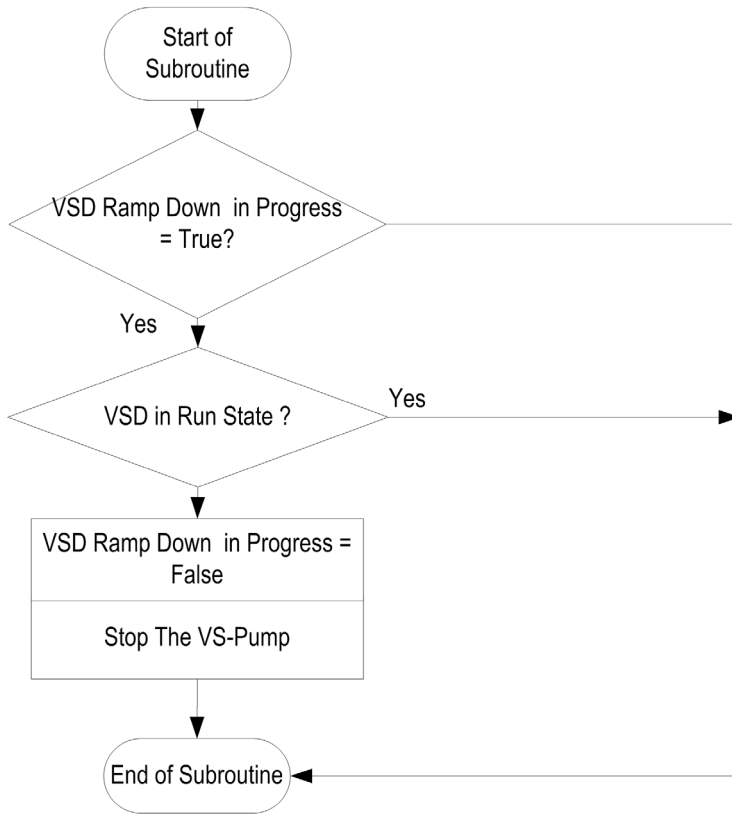

NOTE: The processes to stop a VSD, a VS pump, or an FS pump, consider also the priority defined with the `OpPrty` function block ([see page 108](#)).

NOTE: The stage value can only change sequentially (maximal one step up or down). However, if a VSD, a VS pump or an FS pump simultaneously is no longer available, more than one device can be switched at a time.

Switching VSDs or Pumps According to the Priority

In general, FS pumps are the last devices to be switched on and the first devices to be switched off. This means VSDs and the corresponding VS pumps are the last devices to be switched-off and the first devices to be switched-on. The priority is given to VS pumps over FS pumps. The priority in a device group (VSD, VS pump, FS pump) is flexible and generated by the `OpPrty` function block. This function block generates, with the help of the operating hours of the devices, a priority table for the `DevSwcPumpCtrl` function block. The priority table helps to keep the number of operating hours at an identical level for the different pumps.

The priority function of this library allows you to use another procedure of selecting the priority of the devices by using a user-specific defined priority table (*see page 106*). If the `xFlexStart` (element of initialization structure `stSwcPumpInit`) is set to `TRUE`, the VS pumps are started with a VSD. If the VSDs are in use, an active VS pump linked to a VSD bypasses the VSD (direct online) and the now available VSD is used to start the needed VS pump.

The `DevSwcPumpCtrl` function block considers this dynamically changing priority via the outputs from the `OpPrty` function blocks (*see page 108*) for each device (VSD, VS pumps and FS pumps). This means that the devices are switched according to their priority defined in the priority table. If a device of the same type is not available, an alternative device is switched on, if possible.

Function Block Description - DevSwcPumpCtrl

Pin Diagram

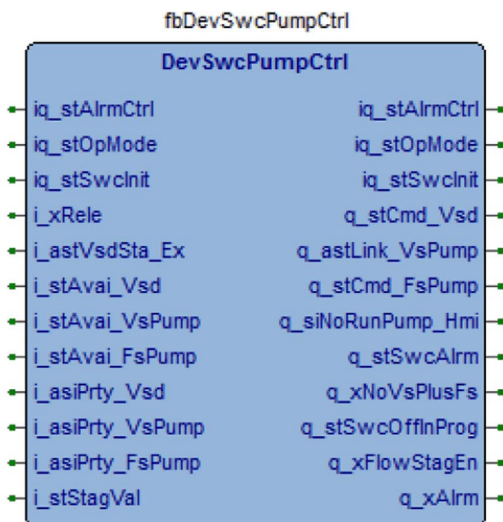

Brief Description

The DevSwcPumpCtrl function block has the following functions:

1.	<p>Verifying the operating mode.</p> <p>This function block only executes its tasks if the pumping application is running in automatic mode. In any other mode, the outputs are constantly set to their default values (0 / FALSE).</p>
2.	<p>Constantly verifying the availability of the used VSDs, VS pumps, and FS pumps. If one of these devices becomes unavailable, the function block switches on another device.</p>
3.	<p>Constantly verifying the stage value and switching VSDs, VS pumps, FS pumps if the stage value changes (see page 38).</p> <ul style="list-style-type: none"> • If the stage value increases, switching a VSD, VS pump, or FS pump to run state considering the general rules and the device priority defined and generated by the OpPrty function block (see page 108). If no alternative device is available, no device is switched. • If the stage value decreases, switching a pump to stop state considering the general rules and the device priority defined and generated by the OpPrty function block (see page 108).
4.	<p>In automatic mode, stopping if an error is detected and switching to manual mode.</p>

5.	Uses the available devices with the help of the general rules and the priority defined and generated by the <code>OpPrty</code> function block.
6.	<p>Verifying whether it is possible to switch to flexible operational mode (see page 53) by evaluating the following questions:</p> <ul style="list-style-type: none"> ● Is no FS pump installed? ● Is the number of VS pumps greater than the number of VSDs? ● Is the bypass option enabled (<code>xByPass = TRUE</code>)? ● Is the fixed link operational mode (see page 56) disabled (<code>xFixLink = FALSE</code>)? <p>The flexible operational mode is the mode with the greatest availability of pumps because the VS pumps can be used independently of VSDs.</p>

I/O Variables Description

The table describes the input/output variables of the function block:

Input/Output	Data Type	Description
<code>iq_stAlarmCtrl</code>	<code>stAlarmCtrl</code>	Structure used for alarm handling. Refer to the structured data type description (see page 154).
<code>iq_stOpMode</code>	<code>stOpMode</code>	Determines the operating modes. If the element <code>xAuto</code> of the structured data type <code>stOpMode</code> is set to TRUE, the function block executes its tasks automatically. With another status of this element, the outputs of this function block are set to their defined fallback (default) states. Refer to the structured data type description (see page 155).
<code>iq_stSwcInit</code>	<code>stSwcInit</code>	Structure used for initialization data. Refer to the structured data type description (see page 48).

The table describes the input variables to the function block:

Input	Data Type	Description
<code>i_xRele</code>	BOOL	Activates (TRUE) or stops (FALSE) the execution of the function block.
<code>i_astVsdSta_Ex</code>	<code>astVsdSta</code>	The array of <code>stVsdSta</code> indicates external VSDs status. Refer to the structured data type description (see page 159).
<code>i_stAvai_Vsd</code>	<code>stAvai</code>	Structure indicating 8 available states provided by the <code>VsdAvai</code> function block (see page 103) indicating whether the VSDs are available (maximum of 4). Refer to the structured data type description (see page 156).

Input	Data Type	Description
i_stAvai_VsPump	stAvai	Structure indicating 8 available states provided by the PumpAvai function block (see page 99) indicating whether the VS pumps are available (maximum of 8). Refer to the structured data type description (see page 156).
i_stAvai_FsPump	stAvai	Structure indicating 8 available states provided by the PumpAvai function block (see page 99) indicating whether the FS pumps are available (maximum of 8). Refer to the structured data type description (see page 156).
i_asiPrty_Vsd	ARRAY [0..7] of SINT	Priority value table for the VSDs provided by the OpPrty function block (see page 108).
i_asiPrty_VsPump	ARRAY [0..7] of SINT)	Priority value table for the VS pumps provided by the OpPrty function block (see page 108).
i_asiPrty_FsPump	ARRAY [0..7] of SINT	Priority value table for the FS pumps provided by the OpPrty function block (see page 108).
i_stStagVal	stStagVal	Structure of the stage value provided by the PumpPidStag function block (see page 23). It indicates the number of pumps that is needed to generate sufficient power to maintain the user-defined pressure level. Refer to the structured data Type description (see page 157).

The table describes the output variables from the function block:

Output	Data Type	Description
q_stCmd_Vsd	stCmd	Structure used for switching the VSDs (maximum of 8) into run state. Refer to the structured data Type description (see page 157).
q_astLink_VsPump	ARRAY [0..7] of stLink	Output array of stLink to link the VS pumps (maximum of 8) dynamically or constantly to one of the VSDs or directly to the power source (direct online) by using contactors. Refer to the structured data type description (see page 160).
q_stCmd_FsPump	stCmd	Structure used for switching the FS pumps (maximum of 8) into run state. Refer to the structured data type description (see page 157).
q_siNoRunPump_Hmi	SINT	Contains the number of pumps that are in run state.

Output	Data Type	Description
q_stSwcAlrm	stSwcAlrm	Structure used for states of detected alarms. Refer to the structured data type description for alarms (see page 154).
q_xNoVsPlusFs	BOOL	Contains the alert status eStage. The stage value is greater than number of pumps.
q_stSwcOffInProg	stSwcOffInProg	Structure to contain the switch-off-process (DCC) in progress message of up to 8 VSDs.
q_xFlowStagEn	BOOL	When TRUE, at least 2 VSD with a corresponding VS pump is available. If no VSD / VS pump is available, this output is set to FALSE. As a result, the PumpPidStag function block stops using the flow value as a basis for stage value calculation (see page 19). It uses the pressure value only (see page 17).
q_xAlrm	BOOL	Alarm flag.

Structured Data Type Definitions - DevSwcPumpCtrl

Overview

Structured data types serve as the major input and output data carriers between different function blocks, configuration, and parameterization data.

The following section lists the names of structures (data types) that are used in this function block, followed by a table that describes the elements of structure.

NOTE: For the structured data types that are used from this function block and others, refer to the Common Structured Data Type Definitions chapter ([see page 154](#)).

Structure: stSwcInit

The stSwcInit structured data type contains the initialization data for the DevSwcPumpCtrl function block (refer to the examples ([see page 50](#))).

Element of stSwcInit	Data Type	Description
siNuVsdMax	SINT	Number of VSDs installed. Range: 0..8
siNuVsPumpMax	SINT	Number of VS pumps installed. Range: 0..8
siNuFsPumpMax	SINT	Number of FS pumps installed. Range: 0..8
siNuVsd	SINT	Maximum number of VSDs that can be used simultaneously. Range: 0..8
siNuVsPump	SINT	Maximum number of VS pumps that can be used simultaneously. Range: 0..8
siNuFsPump	SINT	Maximum number of FS pumps that can be used simultaneously. Range: 0..8
xFlexStart	BOOL	When TRUE, flexible start is used.
xFixLink	BOOL	When TRUE, the links between the VSDs and the VS pumps are fixed.
xByPass	BOOL	When TRUE, the VS pumps can bypass the VSDs.

NOTE: The elements of the structured data type are set to the default values (0 or FALSE) assigned by the controller on system startup.

Structure: stSwcAlarm

The stSwcAlarm structured data type is used to indicate the detected alarm states.

Element of stSwcAlarm	Data Type	Description
xLinkErr	BOOL	When TRUE, it has been detected that the VSD and the VS pump are not in the same state of operation (run or stop).
xStagErr	BOOL	When TRUE, it has been detected that the stage value is not valid because it does not comply with the number of pumps.
xParaErr	BOOL	When TRUE, an error in the configuration has been detected.

Configuration Examples - DevSwcPumpCtrl

Overview

You can configure the `DevSwcPumpCtrl` function block to run in different operational modes.

The following modes are available:

Operational mode	Description
Normal mode	<p>The <code>DevSwcPumpCtrl</code> function block can switch variable speed drives (VSDs), variable speed pumps (VS pumps), and fixed speed pumps (FS pumps) by establishing flexible links between VSDs and VS pumps.</p> <p>During normal operation, each type of pump runs in the defined operational mode. This means that VS pumps are operated in conjunction with a VSD.</p> <p>This operational mode is available if the following conditions apply:</p> <ul style="list-style-type: none"> ● the flexible start <code>FlexStart</code> (see page 38) is disabled ● the fixed link operational mode is disabled ● the bypass option is enabled.
flexible mode	<p>The VS pumps can be used independently of VSDs. This improves the availability of the machine.</p> <p>This operational mode is available if the following conditions apply:</p> <ul style="list-style-type: none"> ● no FS pumps are configured ● the number of available VS pumps is greater than the number of VSDs ● the bypass option is enabled ● the fixed link operational mode is disabled <p>If the flexible operational mode is available, the flexible start <code>FlexStart</code> (see page 38) can be used.</p>
fixed link mode	<p>Each VSD is physically connected to 1 VS pump. In this operational mode, you can enable or disable the bypass option with the <code>xByPass</code> parameter (see page 48).</p> <p>This operational mode is available if the following conditions apply:</p> <ul style="list-style-type: none"> ● the flexible start <code>FlexStart</code> (see page 38) is disabled ● the fixed link operational mode is enabled.

Bypass Option

It is possible to disconnect the VS pumps from the VSD and operate the pump directly with an independent contactor. With this bypass option, the VS pumps are connected to the power source (direct online) for the case a VSD becomes unavailable.

NOTE: In flexible operational mode, the bypass option is enabled. In fixed link operational mode, you can enable or disable the bypass option with the `xByPass` parameter ([see page 48](#)).

Configuration Examples

This section provides configuration examples for each mode. These examples and their values only apply to one pump group for one pressure level.

- normal mode with redundant VS pump ([see page 52](#))
- flexible operational mode ([see page 53](#))
- fixed link operational mode
 - with bypass option enabled ([see page 56](#))
 - with bypass option disabled ([see page 58](#))

To configure the `DevSwcPumpCtrl` function block for one of these modes, set the initialization data with the structured data type `stSwcInit` as listed in the following examples.

NOTE: The following examples are for information only and do not reflect a specific installation.

Example 1: Normal Mode with Redundant VS Pump

This example demonstrates a pumping application in normal mode with 1 redundant VS pump. There are 3 VS pumps installed, however only 2 VS pumps can run simultaneously.

In this example:

- 3 VS pumps (1 of which is redundant)
- 3 FS pumps
- 2 VSDs

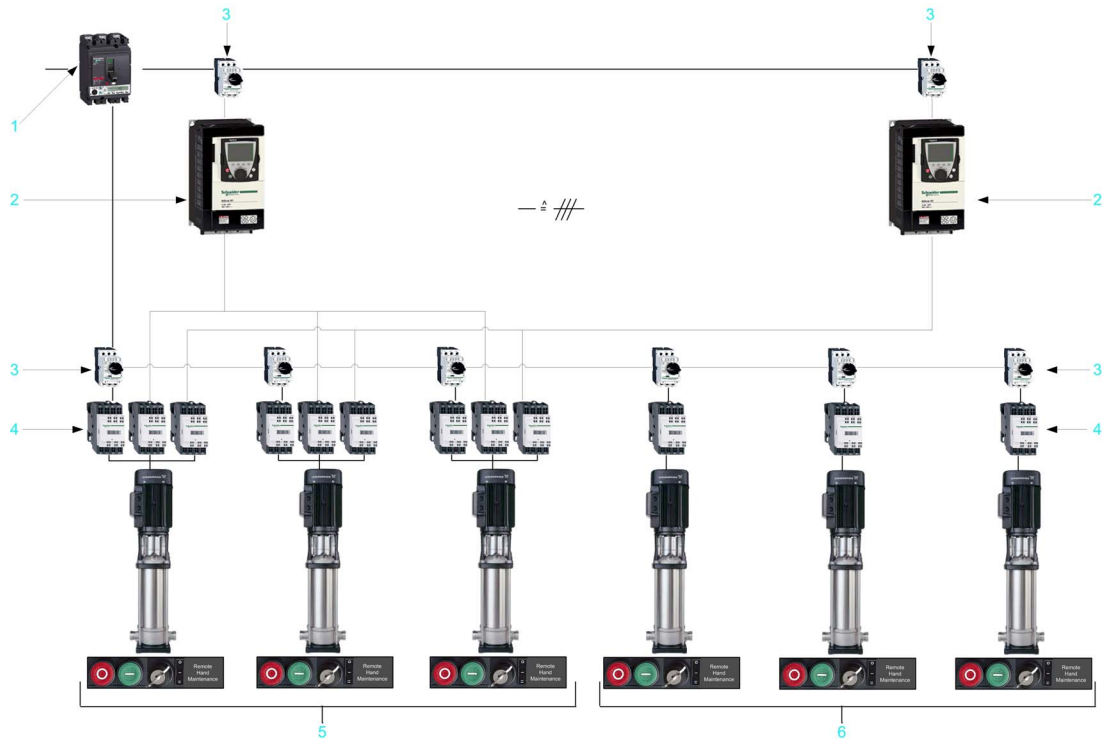

- 1 power switch
- 2 VSD (variable speed drives)
- 3 motor switches
- 4 contactors
- 5 VS (variable speed) pumps
- 6 FS (fixed speed) pumps

To configure the `DevSwcPumpCtrl` function block for normal mode, set the parameters of the instance of the `stSwcInit` structured data type as follows:

Parameter	Value	Description
<code>siNuVsdMax</code>	2	Number of VSDs installed.
<code>siNuVsPumpMax</code>	3	Number of VS pumps installed.
<code>siNuFsPumpMax</code>	3	Number of FS pumps installed.
<code>siNuVsd</code>	2	Maximum number of VSDs that can run simultaneously.
<code>siNuVsPump</code>	2	Maximum number of VS pumps that can run simultaneously.
<code>siNuFsPump</code>	3	Maximum number of FS pumps that can run simultaneously.
<code>xFlexStart</code>	FALSE (0)	Flexible start is disabled.
<code>xFixLink</code>	FALSE (0)	There are no fixed links between the VSDs and the VS pumps.
<code>xByPass</code>	TRUE (1)	It is allowed to operate the VS pumps bypassing the VSD.

Example 2: Flexible Operational Mode

This example shows a pumping application in flexible operational mode.

This mode is available if the following conditions apply:

- no FS pumps configured
- the number of available VS pumps is greater than the number of VSDs
- the bypass option is enabled
- the fixed link operational mode is disabled

The flexible operational mode is the mode with the greatest availability of pumps because the VS pumps can be used independently of VSDs.

This architecture is possible to run in flexible start. If the `xFlexStart` (element of initialization structure `stSwcPumpInit`) is set to TRUE the VS pumps are started with a VSD. If the VSDs are in use, an active VS pump linked to a VSD bypasses the VSD (direct online) and the now available VSD is used to start the needed VS pump.

In this example:

- 8 VS pumps
- 2 VSDs

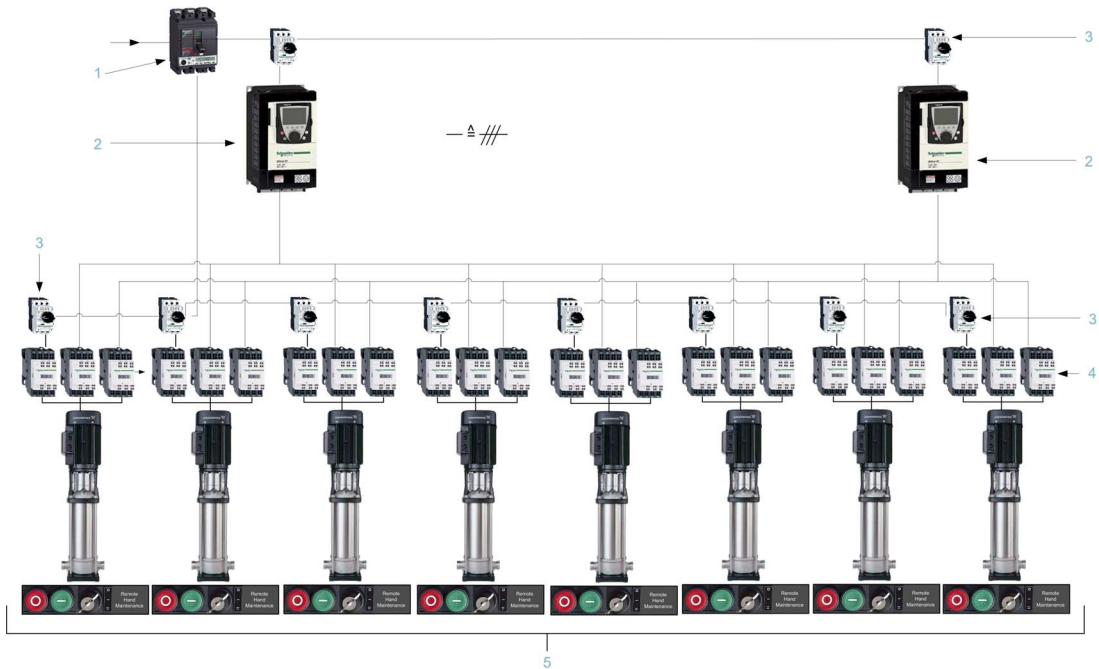

- 1 power switch
- 2 VSD (variable speed drives)
- 3 motor switches
- 4 contactors
- 5 VS (variable speed) pumps

To configure the `DevSwcPumpCtrl` function block for flexible operational mode, set the parameters of the instance of the `stSwcInit` structured data type as follows:

Parameter	Value	Description
<code>siNuVsdMax</code>	2	Number of VSDs installed.
<code>siNuVsPumpMax</code>	8	Number of VS pumps installed.
<code>siNuFsPumpMax</code>	0	Number of FS pumps installed.
<code>siNuVsd</code>	2	Maximum number of VSDs that can run simultaneously.
<code>siNuVsPump</code>	8	Maximum number of VS pumps that can run simultaneously.
<code>siNuFsPump</code>	0	Maximum number of FS pumps that can run simultaneously.

Parameter	Value	Description
xFlexStart	TRUE (1)	Flexible start is used.
xFixLink	FALSE (0)	There are no fixed links between the VSDs and the VS pumps.
xByPass	TRUE (1)	It is allowed to operate the VS pumps bypassing the VSD.

Example 3: Fixed Link Operational Mode With Bypass Option Enabled

This example shows a pumping application in fixed link operational mode with the bypass option enabled. This means that each VSD is constantly linked to 1 VS pump but if a VSD becomes unavailable, the VS pump can be directly connected to the power source (direct online).

In this example:

- 2 VS pumps
- 2 FS pumps
- 2 VSDs

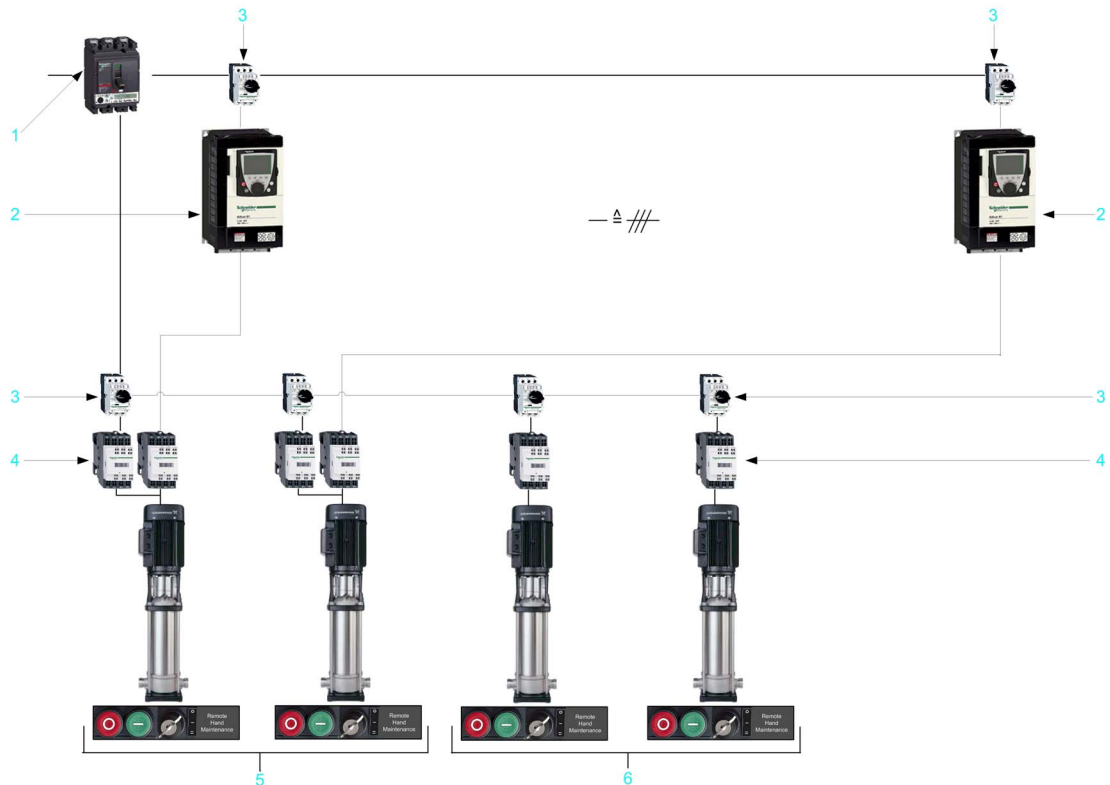

- 1 power switch
- 2 VSD (variable speed drives)
- 3 motor switches
- 4 contactors
- 5 VS (variable speed) pumps
- 6 FS (fixed speed) pumps

To configure the `DevSwcPumpCtrl` function block for fixed link operational mode with the bypass option enabled, set the parameters of the instance of the `stSwcInit` structured data type as follows:

Parameter	Value	Description
<code>siNuVsdMax</code>	2	Number of VSDs installed.
<code>siNuVsPumpMax</code>	2	Number of VS pumps installed.
<code>siNuFsPumpMax</code>	2	Number of FS pumps installed.
<code>siNuVsd</code>	2	Maximum number of VSDs that can run simultaneously.
<code>siNuVsPump</code>	2	Maximum number of VS pumps that can run simultaneously.
<code>siNuFsPump</code>	2	Maximum number of FS pumps that can run simultaneously.
<code>xFlexStart</code>	FALSE (0)	Flexible start is disabled.
<code>xFixLink</code>	TRUE (1)	The links between the VSDs and the VS pumps are fixed.
<code>xByPass</code>	TRUE (1)	It is allowed to operate the VS pumps bypassing the VSD.

Example 4: Fixed Link Operational Mode With Bypass Option Disabled

This example shows a pumping application in fixed link operational mode with the bypass option disabled. This means that each VSD is constantly linked to 1 VS pump. Since the bypass option is disabled, a VS pump becomes unavailable if the corresponding VSD becomes unavailable.

In this example:

- 2 VS pumps
- 2 FS pumps
- 2 VSD



- 1 power switch
- 2 VSD (variable speed drives)
- 3 motor switches
- 4 contactors

- 5 VS (variable speed) pumps
- 6 FS (fixed speed) pumps

To configure the `DevSwcPumpCtrl` function block for fixed link operational mode with the bypass option disabled, set the parameters of the instance of the `stSwcInit` structured data type as follows:

Parameter	Value	Description
<code>siNuVsdMax</code>	2	Number of VSDs installed.
<code>siNuVsPumpMax</code>	2	Number of VS pumps installed.
<code>siNuFsPumpMax</code>	2	Number of FS pumps installed.
<code>siNuVsd</code>	2	Maximum number of VSDs that can run simultaneously.
<code>siNuVsPump</code>	2	Maximum number of VS pumps that can run simultaneously.
<code>siNuFsPump</code>	2	Maximum number of FS pumps that can run simultaneously.
<code>xFlexStart</code>	FALSE (0)	Flexible start is disabled.
<code>xFixLink</code>	TRUE (1)	The links between the VSDs and the VS pumps are fixed.
<code>xByPass</code>	FALSE (0)	It is not allowed to operate the VS pumps bypassing the VSD.

Section 1.3

VsdCtrl: VSD Control

Overview

This section describes the `VsdCtrl` function block for controlling and switching a maximum of 8 variable speed drives (VSDs).

NOTE: This function block is designed to be used in conjunction with other function blocks of the Pumping Library.

What Is in This Section?

This section contains the following topics:

Topic	Page
Description - <code>VsdCtrl</code>	61
Function Block Description - <code>VsdCtrl</code>	62

Description - VsdCtrl

Overview

The `VsdCtrl` function block executes the following tasks:

- Providing an operating hour counter for the VSDs. This counter is realized by an input/output variable. This allows you to reset or adjust the variable even from HMI or SCADA (supervisory control and data acquisition) systems.
- Detecting alarm states of the VSDs by processing the inputs of external key switches, sensors, and contactors connected to the VSDs.
- Indicating a detected alarm for a VSD if a command has been sent to the VSD and the configured response time has expired without receiving a response.
- Before the switching commands for the VSDs are executed, this function block verifies whether the respective VSD is not in a detected alarm state and may be switched. If an error is detected, the VSD command is set to FALSE (0).

This function is independent of the type of connection to the VSD (fieldbus or hardwired).

The function does not consider inputs that are not used (unresolved inputs are declared inactive).

The inputs to this function block concerning the status of the VSD are only active if a variable is linked to them.

Function Block Description - VsdCtrl1

Pin Diagram

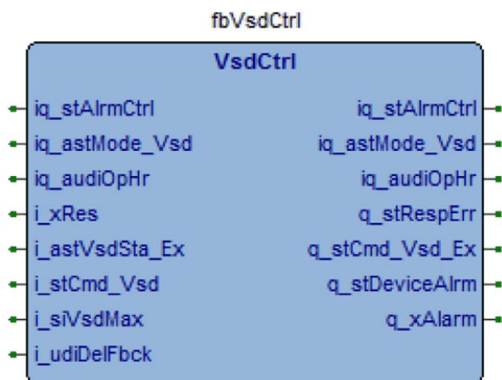

Brief Description

The `VsdCtrl` function block executes the following tasks:

- Providing operating hour counters for the VSDs.
- Indicating a detected alarm for a VSD if the configured response time has expired.
- Verifying whether the respective VSDs are available before the switch command is mapped from the input to the output. Otherwise, the output (command bit) of the unavailable VSD is set to FALSE (stop).
- Generating of an alarm flag for each VSD.

I/O Variables Description

The table describes the input/output variables of the function block:

Input/Output	Data Type	Description
<code>iq_stAlrmCtrl</code>	<code>stAlrmCtrl</code>	Structure used for alarm handling. Refer to the structured data type description (see page 154).
<code>iq_astMode_Vsd</code>	ARRAY [0..7] of <code>stMode</code>	Array of <code>stMode</code> to control and switch the operating mode of the VSDs (maximum of 8). Refer to the structured data type description (see page 157).
<code>iq_audiOpHr</code>	ARRAY [0..7] of UDINT	This array is a table listing the operating hours of the VSDs (maximum of 8). This input/output variable can be reset or adjusted, including from HMI or SCADA systems.

The table describes the input variables to the function block:

Input	Data Type	Description
i_xRes	BOOL	Resets alarms detected in the VSDs if the cause has been corrected.
i_astVsdSta_Ext	ARRAY [0..7] of stVsdSta	Array of stVsdSta. Contains the external status information from up to 8 VSDs. Refer to the structured data type description (see page 159).
i_stCmd_Vsd	stCmd	Structure for switching the VSDs into run state (maximum of 8). Refer to the structured data type description (see page 157).
i_siVsdMax	SINT	Contains the number of installed VSDs.
i_udiDelFbck	UDINT	Defines the maximum time (in milliseconds) allowed for the VSD to send a response. Default: i_udiDelFbck = 1000 As soon as the command is not equal to the response message received from the VSD, a timer is started. If the time defined with this parameter expires without receiving a response equal to the command, then the VsdCtrl function block sets the output q_stRespErr.xDev(n) for the respective VSD to TRUE to indicate that an error has been detected (see page 163).

The table describes the output variables from the function block:

Output	Data Type	Description
q_stRespErr	stRespErr	Structure that indicates detected errors in the pumps (maximum of 8). Refer to the structured data type description (see page 157).
q_stCmd_Vsd_Ext	ARRAY [0..7] of stCmd	Structure used for switching the VSDs into run state (maximum of 8). Refer to the structured data type description (see page 157).
q_stDeviceAlrm	stDeviceAlrm	Structure which contains the VSD alarm flags. Refer to the structured data type description (see page 163).
q_xAlarm	BOOL	When TRUE, indicates that an alarm state has been detected by the VSD(s).

Section 1.4

VsPumpCtrl: Variable Speed Pump Control

Overview

This section describes the VsPumpCtrl function block for controlling and switching a maximum of 8 VS pumps.

NOTE: This function block is designed to be used in conjunction with other function blocks of the Pumping Library.

What Is in This Section?

This section contains the following topics:

Topic	Page
Description - VsPumpCtrl	65
Function Block Description - VsPumpCtrl	66

Description - VsPumpCtrl

Overview

The `VsPumpCtrl` function block executes the following tasks:

- Providing an operating hour counter for the VS pumps. This counter is realized by an input/output variable. This allows you to reset or adjust the variable even from HMI or SCADA systems.
- Detecting alarm states of the VS pumps by processing the inputs of external key switches, sensors, and contactors connected to the VS pumps.
- Indicating a detected alarm for a VS pump if a command has been sent to the VS pump and the configured response time has expired without receiving a response.
- Before the switching commands for the VS pumps are executed, this function block verifies whether the respective VS pump is not in a detected alarm state and may be switched. If an error is detected, the pump command is set to FALSE (0).

This function is independent of the type of connection to the VS pump (fieldbus or hardwired).

The function does not consider inputs that are not used (unresolved inputs are declared inactive).

The inputs to this function block concerning the status of the VS pump are only active if a variable is linked to them.

Function Block Description - VsPumpCtrl

Pin Diagram

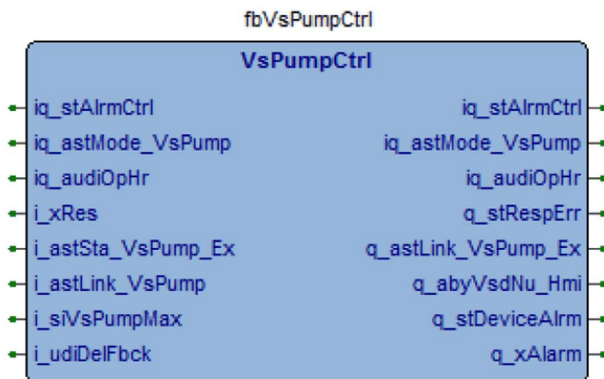

Brief Description

The VsPumpCtrl function block executes the following tasks:

- Providing an operating hour counter for the VS pumps.
- Indicating a detected alarm for a VS pump if the configured response time has expired.
- Verifying whether the respective VS pumps are available before the switch command is mapped from the input to the output. Otherwise the output (command bit) of the not available VS pump is set to FALSE (stop).
- Generating of an alarm flag for each VSD.

I/O Variables Description

The table describes the input/output variables of the function block:

Input/Output	Data Type	Description
iq_stAlrmCtrl	stAlrmCtrl	Structure used for alarm handling. Refer to the structured data type description (see page 154).
iq_astMode_VsPump	ARRAY [0..7] of stMode	Array of stMode to control and switch the operating mode of the VS pumps (maximum of 8). Refer to the structured data type description (see page 157).
iq_audiOpHr	ARRAY [0..7] of UDINT	This array is a table listing the operating hours of the VS pumps (maximum of 8). This input/output variable can be reset or adjusted, including from HMI or SCADA systems.

The table describes the input variables to the function block:

Input	Data Type	Description
i_xRes	BOOL	Resets detected VS pump alarm states, if the cause has been corrected.
i_astSta_VsPump_Ex	ARRAY [0..7] of stSta	Array of stSta. Contains the external status information from up to 8 VS pumps. Refer to the structured data type description (see page 158).
i_astLink_VsPump	ARRAY [0..7] of stLink	Array of stLink to link the VS pumps (maximum of 8) dynamically or constantly to one of the VSDs or directly to the power source (direct online) by using contactors. Refer to the structured data type description (see page 160).
i_siVsPumpMax	SINT	Contains the number of installed VS pumps.
i_udiDelFbck	UDINT	Defines the maximum time (in milliseconds) allowed for the VS pump to send a response. Default: i_udiDelFbck = 1000 As soon as the command is not equal to the response message received from the main contactor of the VS pump, a timer is started. If the time defined with this parameter expires without receiving a response equal to the command, then the VsPumpCtrl function block sets the output q_stRespErr.xDev(n) for the respective VS pump to TRUE to indicate that an error has been detected (see page 163).

The table describes the output variables from the function block:

Output	Data Type	Description
q_stRespErr	stRespErr	Structure that indicates detected response errors in the pumps (maximum of 8). Refer to the structured data type description (see page 163).
q_astLink_VsPump_Ex	ARRAY [0..7] of stLink	Array of stLink to link the VS pumps (maximum of 8) dynamically or constantly to one of the VSDs or directly to the power source (direct online) by using contactors. Refer to the structured data type description (see page 160).
q_abyVsdNu_Hmi	ARRAY [0..7] of Byte	Output array of the used VSD numbers. Refer to the structured data type description (see page 163).

Pumping Functions

Output	Data Type	Description
q_stDeviceAlrm	stDeviceAlrm	Structure which contains the VS pump alarm flags.
q_xAlarm	BOOL	When TRUE, indicates that one, or more, VS pump is in an alarm state.

Section 1.5

FsPumpCtrl: Fixed Speed Pump Control

Overview

This section describes the `FsPumpCtrl` function block for controlling and switching a maximum of 8 FS pumps.

NOTE: This function block is designed to be used in conjunction with other function blocks of the Pumping Library.

What Is in This Section?

This section contains the following topics:

Topic	Page
Description - <code>FsPumpCtrl</code>	70
Function Block Description - <code>FsPumpCtrl</code>	71

Description - FsPumpCtrl

Overview

The `FsPumpCtrl` function block executes the following tasks:

- Providing an operating hour counter for the FS pumps. This counter is realized by an input/output variable. This allows you to reset or adjust the variable even from HMI or SCADA systems.
- Detecting alarm states of the FS pumps by processing the inputs of external key switches, sensors, and contactors connected to the FS pumps.
- Indicating a detected alarm for an FS pump if a command has been sent to the FS pump and the configured response time has expired without receiving a response.
- Before the switching commands for the FS pumps are executed, this function block verifies whether the respective FS pump is not in a detected alarm state and may be switched. If an error is detected, the pump command is set to FALSE (0).

This function is independent of the type of connection to the FS pump (fieldbus or hardwired).

The function does not consider inputs that are not used (unresolved inputs are declared inactive).

The inputs to this function block concerning the status of the FS pump are only active if a variable is linked to them.

Function Block Description - FsPumpCtrl

Pin Diagram

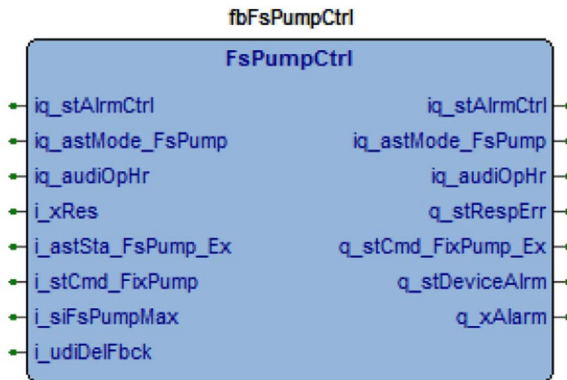

Brief Description

The `FsPumpCtrl` function block executes the following tasks:

- Providing an operating hour counter for the FS pumps.
- Indicating a detected alarm for an FS pump if the configured response time has expired.
- Verifying whether the respective FS pumps are available before the switch command is mapped from the input to the output. Otherwise, the output (command bit) of the not available FS pump is set to FALSE (stop).
- Generating of an alarm flag for each FS pump.

I/O Variables Description

The table describes the input/output variables of the function block:

Input/Output	Data Type	Description
iq_stAlarmCtrl	stAlarmCtrl	Structure used for alarm handling. Refer to the structured data type description (see page 154).
iq_astMode_FsPump	ARRAY [0..7] of stMode	Array of stMode to control and switch the operating mode of the FS pumps (maximum of 8). Refer to the structured data type description (see page 157).
iq_audiOpHr	ARRAY [0..7] of UDINT	This array is a table listing the operating hours of the FS pumps (maximum of 8). This input/output variable can be reset or adjusted, including from HMI or SCADA systems.

The table describes the input variables to the function block:

Input	Data Type	Description
i_xRes	BOOL	Resets detected FS pump alarm states, if the cause has been corrected.
i_astSta_FsPump_Ex	ARRAY [0..7] of stSta	Structure contains the external status information from 8 FS pumps. Refer to the structured data type description (see page 158).
i_stCmd_FixPump	stCmd	Structure for switching the FS pumps into run state (maximum of 8). Refer to the structured data type description (see page 157).
i_siFsPumpMax	SINT	Contains the number of installed FS pumps.
i_udiDelFbck	UDINT	Defines the maximum time (in milliseconds) allowed for the FS pump to send a response. Default: i_udiDelFbck = 1000 As soon as the command is not equal to the response message received from the main contactor of the FS pump, a timer is started. If the time defined with this parameter expires without receiving a response equal to the command, then the FsPumpCtrl function block sets the output q_stRespErr.xDev(n) for the respective FS pump to TRUE to indicate that an error has been detected (see page 163).

The table describes the output variables from the function block:

Output	Data Type	Description
q_stRespErr	stRespErr	Structure that indicates detected response errors from the pumps (maximum of 8). Refer to the structured data type description (see page 163).
q_stCmd_FixPump_Ex	stCmd	Structure used for switching the pumps into run state (maximum of 8). Refer to the structured data type description (see page 157).
q_stDeviceAlrm	stDeviceAlrm	Structure which contains the FS pumps alarm flags. Refer to the structured data type description (see page 163).
q_xAlarm	BOOL	When TRUE, indicates that one, or more, FS pump is in an alarm state.

Section 1.6

CompSp: Setpoint Adaptation (Friction Loss Compensation)

Overview

This section describes the CompSp function block for friction loss compensation by adapting the pressure setpoint according to the stage value.

The following criteria are considered for recalculation of the setpoint:

- the number of pumps that is requested by the stage value
- a ramp function for setpoint integration

NOTE: This function block is designed to be used in conjunction with other function blocks of the Pumping Library.

What Is in This Section?

This section contains the following topics:

Topic	Page
Description - CompSp	74
Function Block Description - CompSp	77
Structured Data Type Definitions - CompSp	79

Description - CompSp

Overview

In order to help to compensate for friction loss, the `CompSp` function block adapts the pressure setpoint (`i_rSp`) after a change of the stage value (`i_stStagVal`) provided by the `PumpPidStag` function block (see page 23) has been detected.

The following criteria are considered for recalculation of the pressure setpoint:

- the demand of the number of pumps (as indicated by the stage value) used as a pointer on a correction value (parameter) for the pressure setpoint
- a ramp function for the adaptation of the last used setpoint value to the newly adapted setpoint.

Increasing the Pressure Setpoint According to the Stage Value

The diagrams illustrate the relationship between the rising flow level (due to a rising stage value) and the increase of the pressure setpoint (i_rSp) to reduce friction loss:

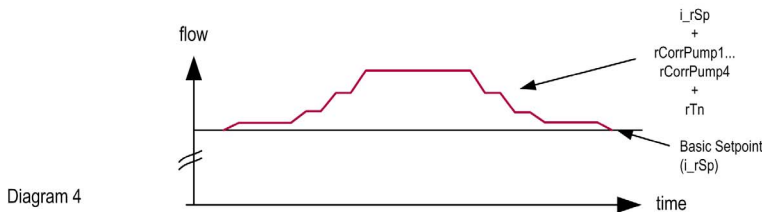
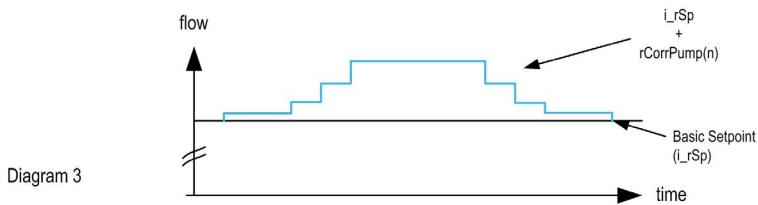
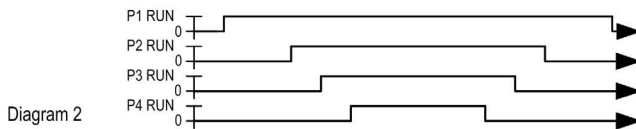
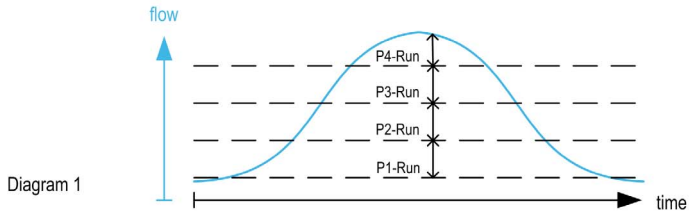

Diagram 1: The diagram shows the dependence of the total number of active pumps to the flow value and in dependence on the time.

Diagram 2: The diagram shows the active pumps in dependence on the time.

Diagram 3: The diagram shows the increase of the setpoint value by a fixed correction value depending on the number of pumps used in dependence of the time.

Diagram 4: This diagram shows the variation of the setpoint adjustment as shown in diagram 3, but with a change in the setpoint corrections with the help of a ramp function.

The flow is increased with every pump that is switched to the run state. To increase the pressure accordingly, a user-defined adjustment value is added to the pressure setpoint (i_rSp). For the stage value of each pump, a specific adjustment value can be configured with the parameters `iq_stCompInit.rCorrPump1` to `iq_stCompInit.rCorrPump8`.

To help avoid an abrupt rise of pressure by adding the adjustment value to the setpoint pressure, a ramp time is defined with the parameter `iq_stCompInit.rTn`.

Function Block Description - CompSp

Pin Diagram

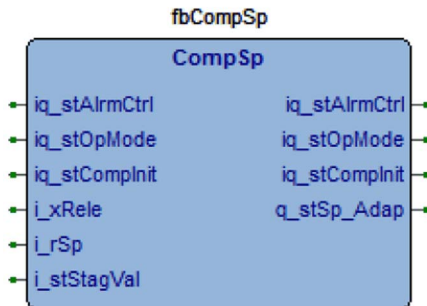

Brief Description

When the stage value changes, the `CompSp` function block helps to reduce friction loss by adapting the pressure setpoint considering the number of the pump demand. The steepness of the adaptation is limited by using a ramp function.

I/O Variables Description

The table describes the input/output variables of the function block:

Input/Output	Data Type	Description
iq_stAlrmCtrl	stAlrmCtrl	Structure used for alarm handling. Refer to the structured data type description (see page 154).
iq_stOpMode	stOpMode	Determines the operating modes. If the element <code>xAuto</code> of the structured data type <code>stOpMode</code> is set to <code>TRUE</code> , the function block executes its tasks automatically. With another status of this element, the outputs of this function block are set to their defined fallback (default) states. Refer to the structured data type description (see page 155).
iq_stCompInit	stCompInit	Structure used for initialization data for the compensation function. Refer to the structured data type description (see page 79).

The table describes the input variables to the function block:

Input	Data Type	Description
i_xRele	BOOL	Activates (TRUE) or stops (FALSE) the execution of the function block.
i_rSp	REAL	Contains the user-defined pressure setpoint and can be adapted by this function, or the pipe fill, or the cavitation protection function.
i_stStagVal	stStagVal	Structure of the stage value provided by the PumpPidStag function block (see page 23). It indicates the number of pumps that is needed to generate sufficient power to maintain the pressure level. The CompSp function block will increase the pressure setpoint (i_rSp) by the respective correction values (iq_stCompInit.rCorrPump(n)) for the number of pumps requested by the stage value. Refer to the structured data type description (see page 157).

The table describes the output variable from the function block:

Output	Data Type	Description
q_stSp_Adap	stSp	Structure for setpoints contains the adapted pressure setpoint and the state of this value. Refer to the structured data type description (see page 163).

Structured Data Type Definitions - CompSp

Overview

Structured data types serve as the major input and output data carriers between different function blocks, configuration, and parameterization data.

The following section lists the names of structures (data types) that are used in this function block, followed by a table that describes the elements of structure.

NOTE: For the structured data types that are used from this function block and others, refer to the Common Structured Data Type Definitions chapter ([see page 154](#)).

Structure: `stCompInit`

The `stCompInit` structured data type contains the initialization data for the `CompSp` function block.

Element of <code>stCompInit</code>	Data Type	Description
<code>rTn</code>	REAL	Defines the stage time (T_n , in milliseconds) for the reference ramp to reach the increased pressure setpoint ($i_rSp + iq_stCompInit.rCorrPump(n)$). Range: $rTn > 0.0$ ms Time required (T_n , in milliseconds) to increase the correction value by 1 unit.
<code>rCorrPump1</code>	REAL	Correction value that is added to the pressure setpoint (i_rSp) if the stage value requests 1 pump.
<code>rCorrPump2</code>	REAL	Correction value that is added to the pressure setpoint (i_rSp) if the stage value requests 2 pumps.
<code>rCorrPump3</code>	REAL	Correction value that is added to the pressure setpoint (i_rSp) if the stage value requests 3 pumps.
<code>rCorrPump4</code>	REAL	Correction value that is added to the pressure setpoint (i_rSp) if the stage value requests 4 pumps.
<code>rCorrPump5</code>	REAL	Correction value that is added to the pressure setpoint (i_rSp) if the stage value requests 5 pumps.
<code>rCorrPump6</code>	REAL	Correction value that is added to the pressure setpoint (i_rSp) if the stage value requests 6 pumps.
<code>rCorrPump7</code>	REAL	Correction value that is added to the pressure setpoint (i_rSp) if the stage value requests 7 pumps.
<code>rCorrPump8</code>	REAL	Correction value that is added to the pressure setpoint (i_rSp) if the stage value requests 8 pumps.

Section 1.7

CompSpFlow: Setpoint Adaptation by Using Flow Value (Friction Loss Compensation)

Overview

This section describes the `CompSpFlow` function block for friction loss compensation by adapting the pressure setpoint according to the flow value provided by the flow meter.

A flow meter is required in your system to use this function.

NOTE: This function block is designed to be used in conjunction with other function blocks of the Pumping Library.

What Is in This Section?

This section contains the following topics:

Topic	Page
Description - <code>CompSpFlow</code>	81
Function Block Description - <code>CompSpFlow</code>	83
Structured Data Type Definitions - <code>CompSpFlow</code>	85

Description - CompSpFlow

Overview

In order to help to compensate for friction loss, the `CompSpFlow` function block adapts the pressure setpoint (`i_rSp`) according to the flow value provided by the flow meter. This helps to maintain a constant pressure even at the highest and/or most distant points of the system.

At least 2 pressure setpoint values together with the respective flow values (the pressure setpoint at minimum flow and the pressure setpoint at maximum flow) have to be configured as measuring points. The pressure values can be defined as a relative increment value (in percent) or an absolute value. The `CompSpFlow` function block allows you to configure a maximum of 6 pressure setpoints with the respective flow values. With the Newton interpolation formula, the function block generates, with the help of the defined measured points, an adapted setpoint.

Increasing the Pressure Setpoint According to the Flow

The diagram illustrates the relationship between the flow and the pressure. 2 measuring points are used to increment the pressure setpoint (`i_rSp`) in order to maintain a constant pressure even at the highest and/or most distant points of the system:

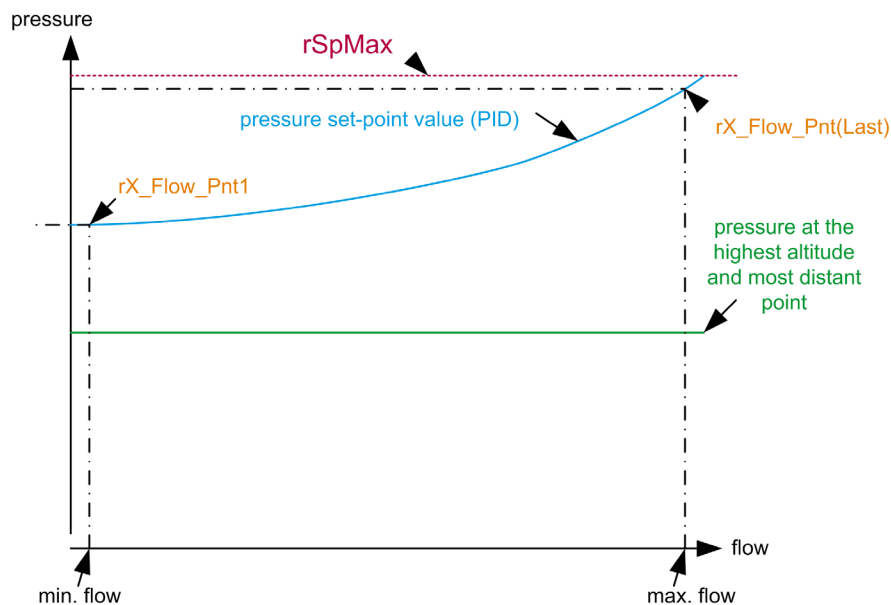

Last = Value from 2...6, here the value is 2

The 2 pressure setpoint values `iq_stCompFlowInit.X_Flow_Pnt1` and `iq_stCompFlowInit.X_Flow_Pnt (Last)` (the pressure setpoint at minimum flow and the pressure setpoint at maximum flow) are defined.

If relative values for the pressure values are used, the pressure value of the measuring point 1 (`iq_stCompFlowInit.X_Flow_Pnt1`) is typically zero. The value of succeeding measuring points (`iq_stCompFlowInit.X_Flow_Pnt(Last)` in this example) must be greater than the preceding measuring point.

If absolute values are used, the pressure value of the measuring point 1 (`iq_stCompFlowInit.X_Flow_Pnt1`) is equal to the user-defined pressure setpoint (`i_rSp`). The value of measuring point `iq_stCompFlowInit.X_Flow_Pnt(Last)` must be greater than the user-defined pressure setpoint (`i_rSp`) and must be less than the user-defined setpoint maximum limit (`iq_stCompFlowInit.rSpMax`). The minimum calculated setpoint is limited by the `i_rSp` value. The maximum calculated setpoint is limited by the `iq_stCompFlowInit.rSpMax` value.

NOTE: If the highest measuring point is not close to the maximum flow, it is possible (due to interpolation) that the setpoint is increased until the value of the parameter `iq_stCompFlowInit.rSpMax` is reached.

Function Block Description - CompSpFlow

Pin Diagram

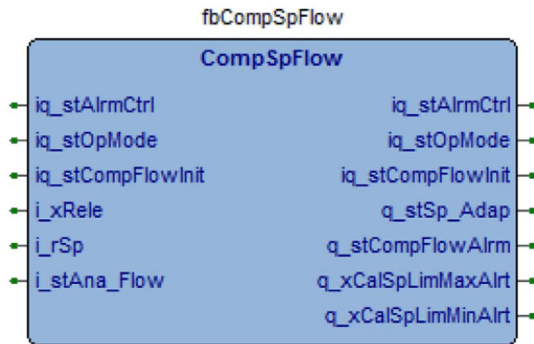

Brief Description

The `CompSpFlow` function block helps to maintain a constant pressure even at the highest and/or most distant points of the system. To achieve this, the pressure setpoint (`i_rSP`) is adapted according to the flow value provided by the flow meter to reduce friction loss.

I/O Variables Description

The table describes the input/output variables of the function block:

Input/Output	Data Type	Description
<code>iq_stAlarmCtrl</code>	<code>stAlarmCtrl</code>	Structure used for alarm handling. Refer to the structured data type description (see page 154).
<code>iq_stOpMode</code>	<code>stOpMode</code>	Determines the operating modes. If the element <code>xAuto</code> of the structured data type <code>stOpMode</code> is set to <code>TRUE</code> , the function block executes its tasks automatically. With another status of this element, the outputs of this function block are set to their defined fallback (default) states. Refer to the structured data type description (see page 155).
<code>iq_stCompFlowInit</code>	<code>stCompFlowInit</code>	Structure used for initialization data for the <code>CompSpFlow</code> function block. Refer to the structured data type description (see page 79).

The table describes the input variables to the function block:

Input	Data Type	Description
i_xRele	BOOL	Activates (TRUE) or stops (FALSE) the execution of the function block.
i_rSp	REAL	Contains the user-defined pressure setpoint. This constant setpoint is considered during startup (pipe fill function) of the pumping process. It is adjusted by this compensation function and by other functions of this library. Range: 0.0...n
i_stAna_Flow	stAna	Structure for analog values, contains the flow input value and the state of this value. Refer to the structured data type description (see page 156).

The table describes the output variables from the function block:

Output	Data Type	Description
q_stSp_Adap	stSp	Structure for setpoints, contains the adapted pressure setpoint and the state of this value. Refer to the structured data type description (see page 163).
q_stCompFlowAlrm	stCompFlowAlrm	Structure that indicates the alarm states detected by the <code>CompSpFlow</code> function block. Refer to the structured data type description of alarms (see page 86).
q_xCalSpLimMaxAlrt	BOOL	Alert: If TRUE, the calculated setpoint is greater than the maximum setpoint.
q_xCalSpLimMinAlrt	BOOL	Alert: If TRUE, the calculated setpoint is less than the setpoint.

Structured Data Type Definitions - CompSpFlow

Overview

Structured data types serve as the major input and output data carriers between different function blocks, configuration, and parameterization data.

The following section lists the names of structures (data types) that are used in this function block, followed by a table that describes the elements of structure.

NOTE: For the structured data types that are used from this function block and others, refer to the Common Structured Data Type Definitions chapter ([see page 154](#)).

Structure: stCompFlowInit

The stCompFlowInit structured data type contains the initialization data for the CompSpFlow function block.

Structure: stSwcAlrm

The stSwcAlrm structure is used to indicate the detected alarm states.

Element of stSwcAlrm	Data Type	Description
rSpMax	REAL	Defines the maximum value allowed for the calculated pressure setpoint.
siNbPnt	SINT	Defines the number of measuring points (stPntn) used (pressure setpoint values together with the respective flow values). At least 2 measuring points are required to use this function. Range: 2...6
eCompTyp	enumeration UDINT	Defines whether the pressure values are relative or absolute values. Range: <ul style="list-style-type: none"> ● relative (= 1) ● absolute (= 2)
rX_Flow_Pnt1	REAL	Flow value for point 1
rY_Pres_Pnt1	REAL	Pressure value for point 1
rX_Flow_Pnt2	REAL	Flow value for point 2
rY_Pres_Pnt2	REAL	Pressure value for point 2
rX_Flow_Pnt3	REAL	Flow value for point 3
rY_Pres_Pnt3	REAL	Pressure value for point 3
rX_Flow_Pnt4	REAL	Flow value for point 4
rY_Pres_Pnt4	REAL	Pressure value for point 4
rX_Flow_Pnt5	REAL	Flow value for point 5
rY_Pres_Pnt5	REAL	Pressure value for point 5

Element of <code>stSwcAlrm</code>	Data Type	Description
<code>rX_Flow_Pnt6</code>	REAL	Flow value for point 6
<code>rY_Pres_Pnt6</code>	REAL	Pressure value for point 6

Structure: `stCompFlowAlrm`

The `stCompFlowAlrm` structured data type is used to indicate a detected alarm:

Element of <code>stCompFlowAlrm</code>	Data Type	Description
<code>xNuAlrm</code>	BOOL	When TRUE, the value of the parameter defining the number of measuring points (<code>stCompFlowInit.siNbPnt</code>) is not within the allowed range (2..6).
<code>xPntXValAlrm</code>	BOOL	When TRUE, the same flow value has been detected more than once.
<code>xPntXSeqAlrm</code>	BOOL	When TRUE, it has been detected that the flow values in <code>stCompFlowInit.rX_Flow_Pnt(n)</code> structure are not monotonically increasing.
<code>xPntYSeqAlrm</code>	BOOL	When TRUE, it has been detected that the pressure values in <code>stCompFlowInit.rY_Pres_Pnt(n)</code> structure are not monotonically increasing.
<code>xPntYHighLimAlrm</code>	BOOL	When TRUE, it has been detected that the adjusted pressure setpoint has exceeded the maximum value. This parameter is available if relative values are used and if the Y value of the measuring point is greater than 100.0%. <code>stCompFlowInit.rY_Pres_Pnt(n) > 100.0%</code>
<code>xPntYLowLimAlrm</code>	BOOL	When TRUE, it has been detected that the adjusted pressure setpoint is below the minimum value. This parameter is available if absolute values are used and if the Y value of the measuring point is less than the pressure setpoint. <code>stCompFlowInit.rY_Pres_Pnt(n) > pressure setpoint(i_rSp)</code>

Section 1.8

CavtProt: Cavitation Protection

Overview

This section describes the CavtProt function block that helps to avoid operating the VS and FS pumps in a cavitation situation. To achieve this, it monitors the suction pressure and adapts the pressure setpoint, if necessary.

NOTE: A pressure sensor providing absolute pressure values is required to implement this function.

NOTICE

CAVITATION CAUSING INOPERABLE EQUIPMENT

Select a pressure sensor providing absolute values and make sure to configure the correct NPSH+ value defined by the manufacturer of the pump you are using.

Failure to follow these instructions can result in equipment damage.

NOTE: This function block is designed to be used in conjunction with other function blocks of the Pumping Library.

What Is in This Section?

This section contains the following topics:

Topic	Page
Description - CavtProt	88
Function Block Description - CavtProt	93
Structured Data Type Definitions - CavtProt	95

Description - CavtProt

Overview

The CavtProt function block helps to avoid operating the VS and FS pumps in a cavitation situation caused by a low-pressure situation on the suction side.

To achieve this, it constantly verifies the suction pressure in the pumping application. The CavtProt function block starts to adapt the pressure setpoint if the suction pressure value drops below a certain cavitation protection start limit. If this measure does not stop the decrease of the suction pressure, a second limit value, referred to as NPSH+, is used. This value is a value provided by the manufacturer of the pumps. It indicates the minimum pressure that has to be available at the entry point of the pump to prevent the liquid from boiling and thus to avoid a cavitation situation. If the suction pressure drops below the NPSH+ value, the CavtProt function block indicates an alarm. As a result, the pumps are stopped.

Cavitation Protection Procedure

The diagram illustrates the influence of the suction pressure on the pressure setpoint during cavitation protection:

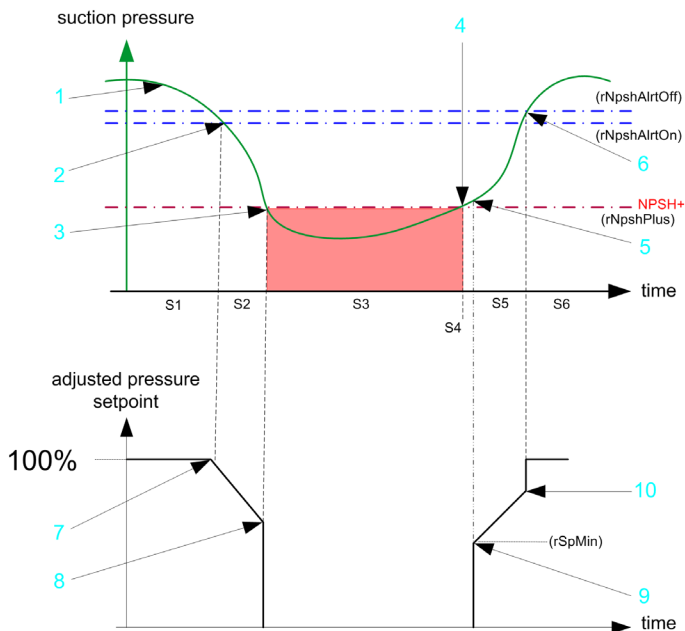

- 1 Suction pressure curve
- 2 The suction pressure becomes inferior to the suction pressure alert on-limit ($iq_stCavtInit.rNpshAlrtOn$), triggering the active cavitation protection.
- 3 The suction pressure reaches the NPSH+ threshold; alarm state = TRUE (1); pumps are stopped.
- 4 The suction pressure leaves the NPSH+ alarm area.

- 5 A user reset command and a user automatic command starts the machine.
- 6 The suction pressure exceeds the suction pressure alert off-limit (`iq_stCavtInit.rNpshAlrtOff`), terminating the active cavitation protection.
- 7 During the active phase of the cavitation protection, the setpoint is adjusted.
- 8 During an alarm state, the value of the setpoint is set to zero.
- 9 After a user reset command, the active cavitation protection starts to adjust the setpoint with the `iq_stCavtInit.rSpMin` as start value.
- 10 If the active cavitation protection ends, the setpoint is set to 100% (`q_stSp_Adap.rVal:=i_rSp`).

The cavitation protection process consists of the following stages:

Stage	Description
1	The suction pressure in the pumping application is constantly verified during normal operation.
2	<p>If the suction pressure drops under the lower suction pressure limit value (position 1: <code>q_stCavtSta_Hmi.rNpshAlrtOn</code>), the cavitation protection function starts and the <code>CavtProt</code> function block executes the following actions:</p> <ul style="list-style-type: none"> ● The operating mode is set to cavitation margin mode (<code>iq_stOpMode.xCavtMarg</code>). ● The output value <code>q_stCavtSta_Hmi.xProtActv</code> is set to TRUE (1) to indicate that the cavitation protection function is in progress. ● The output value <code>q_xSuctPresLim</code> is set to TRUE (1) to indicate that a cavitation alert has been detected. ● The pressure setpoint is adjusted according to the suction pressure value in order to reduce the flow and to increase the suction pressure.
3	<p>If the suction pressure drops to the NPSH+ limit (<code>iq_stCavtInit.rNpshPlus</code>) (position 2), the <code>CavtProt</code> function block stops the pumps by executing the following actions:</p> <ul style="list-style-type: none"> ● It indicates a detected cavitation alarm (by setting output <code>q_stCavtAlrm.xSuctPresNpsh</code> to TRUE (1)). ● It sets the outputs to the default values (0 and FALSE (0)). ● It sets the alarm release bit (<code>iq_stAlrmCtrl.xAlrmRele</code>) to FALSE (0). ● It sets the operating mode to manual mode.
4	Once the suction pressure is greater than the NPSH+ limit (<code>iq_stCavtInit.rNpshPlus</code>), a reset must be executed to restart the pumps.
5	<p>After the reset has been carried out, the cavitation logic resumes while the suction pressure is below the upper suction pressure alert on-limit (<code>iq_stCavtInit.rNpshAlrtOn</code>). The <code>CavtProt</code> function block executes the following actions:</p> <ul style="list-style-type: none"> ● The cavitation margin mode flag (<code>iq_stOpMode.xCavtMarg</code>) into the operating mode structure is set to TRUE. ● The output value <code>q_stCavtSta_Hmi.xProtActv</code> is set to TRUE (1) to indicate that the cavitation protection function is in progress. ● The output value <code>q_xSuctPresLim</code> is set to TRUE (1) to indicate that a cavitation alert has been detected. ● The value configured for the parameter <code>iq_stCavtInit.rSpMin</code> (position 9) is used as the first pressure setpoint during restart after a reset. In the course of time the pressure setpoint is adapted according to the sign of the measured suction pressure gradient. If the suction pressure is rising, the pressure setpoint is incremented, and vice versa. The adjustment is realized with the value of the time constants TN (<code>iq_stCavtInit.rTn</code>).

Stage	Description
6	<p>As soon as the suction pressure alert off-limit (<code>iq_stCavtInit.rNpshAlrtOff</code>) is reached, the cavitation protection action is stopped, and the <code>CavtProt</code> function block executes the following actions:</p> <ul style="list-style-type: none">● The cavitation margin mode flag (<code>iq_stOpMode.xCavtMarg</code>) of the operating mode is set to FALSE (0).● The output value <code>q_stCavtSta_Hmi.xProtActv</code> is set to FALSE (0).● The setpoint is set to 100% (<code>q_stSp_Adap.rVal:=i_rSp</code>).● The suction pressure in the pumping application is constantly verified.

Pressure Setpoint Adaptation

The diagram shows the pressure setpoint being adapted according to the suction pressure.

In this example, the reduction of the pressure setpoint and the flow is sufficient to prevent the suction pressure from dropping below the NPSH+ limit:

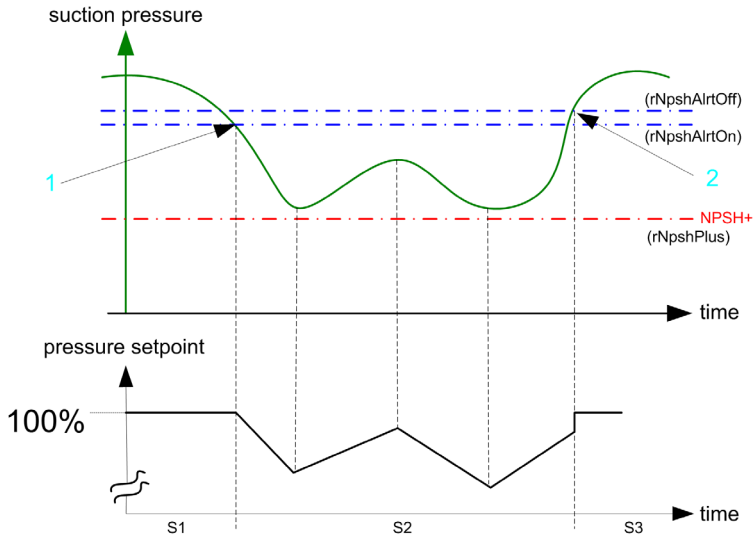

- 1 The suction pressure falls under the suction pressure alert on-limit (`iq_stCavtInit.rNpshAlrtOn`), triggering the starting of the active cavitation protection phase.
- 2 The suction pressure exceeds the suction pressure alert off-limit (`iq_stCavtInit.rNpshAlrtOff`), terminating the active cavitation protection phase.

The cavitation protection function adapts the pressure setpoint according to the suction pressure as follows:

Stage	Description
1	The suction pressure in the pumping application is constantly verified during normal operation.
2	<p>If the suction pressure drops below the suction pressure alert on-limit value (position 1: <code>iq_stCavtInit.rNpshAlrtOn</code>), the cavitation protection function starts and the <code>CavtProt</code> function block executes the following actions:</p> <ul style="list-style-type: none"> ● The cavitation margin mode flag (<code>iq_stOpMode.xCavtMarg</code>) into the operating mode structure is set to TRUE. ● The output value <code>q_stCavtSta_Hmi.xProtActv</code> is set to TRUE (1) to indicate that the cavitation protection function is in progress. ● The output value <code>q_xSuctPresLim</code> is set to TRUE (1) to indicate that a cavitation alert has been detected. ● The pressure setpoint is adjusted according to the sign of the measured suction pressure gradient. If the suction pressure is rising, the pressure setpoint is incremented, and vice versa. The adjustment is realized with the value of the time constants <code>TN</code> (<code>rTn</code>).
3	<p>As soon as the suction pressure value reaches the suction pressure alert off-limit position 2: <code>iq_stCavtInit.rNpshAlrtOff</code>, the cavitation protection adjustment is stopped and the <code>CavtProt</code> function block executes the following actions:</p> <ul style="list-style-type: none"> ● The cavitation margin mode flag (<code>iq_stOpMode.xCavtMarg</code>) of the operating mode is set to FALSE (0). ● The output value <code>q_stCavtSta_Hmi.xProtActv</code> is set to FALSE (0). ● The setpoint is set to 100% (<code>q_stSp_Adap.rVal:=i_rSp</code>). ● The suction pressure in the pumping application is constantly verified.

Function Block Description - CavtProt

Pin Diagram

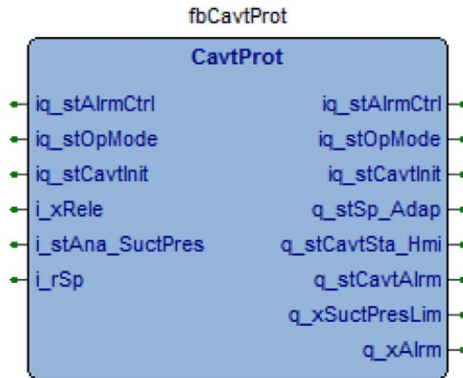

Brief Description

The `CavtProt` function block helps to avoid operating the VS and FS pumps in a cavitation situation. To achieve this, it constantly verifies the suction pressure in the pumping application and adapts the setpoint of the PID control function, if necessary. If in spite of this measure the suction pressure drops below the NPSH+ value, the `CavtProt` function block indicates a detected alarm, induces the stop of the pumping application, by setting the `iq_stAlrmCtrl.xAlrmRele` bit to FALSE (0) to help avoid pump damage.

I/O Variables Description

The table describes the input/output variables of the function block:

Input/Output	Data Type	Description
<code>iq_stAlrmCtrl</code>	<code>stAlrmCtrl</code>	Structure used for alarm handling. Refer to the structured data type description (see page 154).
<code>iq_stOpMode</code>	<code>stOpMode</code>	Determines the operating modes. If the element <code>xAuto</code> of the structured data type <code>stOpMode</code> is set to TRUE, the function block executes its tasks automatically. With another status of this element, the outputs of this function block are set to their defined fallback (default) states. Refer to the structured data type description (see page 155).
<code>iq_stCavtInit</code>	<code>stCavtInit</code>	Structure used for initialization data for the cavitation protection function. Refer to the structured data type description (see page 154).

The table describes the input variables to the function block:

Input	Data Type	Description
i_xRele	BOOL	Activates (TRUE) or stops (FALSE) the execution of the function block.
i_stAna_SuctPres	stAna	Structure used for the analog suction pressure input value and the state of this value. Refer to the structured data type description (see page 156).
i_rSp	REAL	Contains the user-defined pressure setpoint. This constant setpoint is considered during startup (pipe fill function (see page 122)) of the pumping process. It is adapted by this cavitation function and can be adapted by other functions of this library, if used (ComSp (see page 77) and CompSpFlow (see page 83)). To help to prevent a cavitation situation, this value is adjusted by the CavtProt function block. The adjusted setpoint is provided by the output parameter q_stSp_Adap.

The table describes the output variables from the function block:

Output	Data Type	Description
q_stSp_Adap	stSp	Structure for setpoints contains the adapted pressure setpoint and the state of this value. Refer to the structured data type description (see page 163).
q_stCavtSta_Hmi	stCavtSta	Structure that is used to display the status of the cavitation protection function on the HMI. Refer to the structured data type description (see page 162).
q_stCavtAlrm	stCavtAlrm	Structure used for states of alarms detected by the cavitation protection function. Refer to the structured data type description for detected cavitation protection alarms (see page 96).
q_xSuctPresLim	BOOL	If TRUE, the boolean output pin indicates that the suction pressure has fallen below the alert limit.
q_xAlrm	BOOL	If TRUE, the boolean output pin indicates the alarm state of the function.

Structured Data Type Definitions - CavtProt

Overview

Structured data types serve as the major input and output data carriers between different function blocks, configuration, and parameterization data.

The following section lists the names of structures (data types) that are used in this function block, followed by a table that describes the elements of structure.

NOTE: For the structured data types that are used from this function block and others, refer to the Common Structured Data Type Definitions chapter ([see page 154](#)).

Structure: stCavtInit

The stCavtInit structured data type contains the initialization data for the CavtProt function block.

Element of stCavtInit	Data Type	Description
rNpshPlus	REAL	Defines the NPSH+ value as defined by the manufacturer of the pumps. If the suction pressure drops below this value, the pumping application is stopped and an alarm is detected.
rNpshAlrtOn	REAL	Defines the lower suction pressure limit value. If the suction pressure drops below this value, the cavitation protection procedure starts and an alert is detected. Range: rNpshAlrtOn > rNpshPlus
rNpshAlrtOff	REAL	Defines the upper suction pressure limit value. If the suction pressure exceeds this value, the cavitation protection procedure stops and an alert is cleared. Range: rNpshAlrtOff > rNpshAlrtOn
rSpMin	REAL	Defines the minimal setpoint value for the pressure. The setpoint adaptation of the function uses this limit value for the minimum of the adapted pressure setpoint value. After a reset of a detected NPSH+ alarm, this is the first (minimum) pressure value that is used as a setpoint. In the course of time, the pressure setpoint is adjusted according to the measured suction pressure value. Range: rSpMin > 0

Element of <code>stCavtInit</code>	Data Type	Description
<code>rTn</code>	REAL	Defines the stage time (Tn , in milliseconds) for the reference ramp. Range: $rTn > 0.0$ ms The time required to increase the correction value by 1 unit.

Structure: `stCavtAlrm`

The `stCavtAlrm` structured data type is used to indicate the alarm states detected during cavitation protection.

Element of <code>stCavtAlrm</code>	Data Type	Description
<code>xSuctPresNpsh</code>	BOOL	When TRUE, the suction pressure has dropped below the NPSH+ value.
<code>xSuctPresSta</code>	BOOL	When TRUE, it has been detected that the suction pressure value is not valid.

Section 1.9

PumpAvai: Pump Availability Status

Overview

This section describes the PumpAvai function block for indicating the availability of a maximum of 8 pumps.

NOTE: This function block is designed to be used in conjunction with other function blocks of the Pumping Library.

What Is in This Section?

This section contains the following topics:

Topic	Page
Description - PumpAvai	98
Function Block Description - PumpAvai	99

Description - PumpAvai

Overview

The PumpAvai function block indicates the availability of a maximum of 8 pumps by processing the inputs of external key switches, sensors, and contactors.

NOTE: It indicates the availability of a functional homogenous set of pumps. You would need one instance of this function block for VS pumps and one instance of this function block for FS pumps, if any.

The inputs processed by the function block may include:

- the mode of the pump (hand mode or maintenance mode)
- a detected alarm (for example, dry run or temperature)
- a detected hardware error (for example, motor circuit breaker tripped)
- a detected connection loss between the controller and distributed I/O modules that may be involved in detecting the status of the pump

Function Block Description - PumpAvai

Pin Diagram

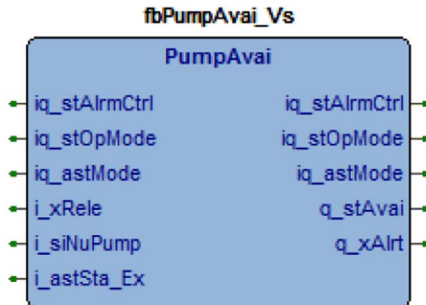

Brief Description

The PumpAvai function block verifies the status and the operating modes of a maximum of 8 pumps to indicate their availability to the other function blocks.

I/O Variables Description

The table describes the input/output variables of the function block:

Input/Output	Data Type	Description
iq_stAlrmCtrl	stAlrmCtrl	Structure used for alarm handling. Refer to the structured data type description (see page 154).
iq_stOpMode	stOpMode	Determines the operating modes. If the element <code>xAuto</code> of the structured data type <code>stOpMode</code> is set to TRUE, the function block executes its tasks automatically. With another status of this element, the outputs of this function block are set to their defined fallback (default) states. Refer to the structured data type description (see page 155).
iq_astMode	ARRAY [0..7] of stMode	Array of <code>stMode</code> to control and switch the operating mode of the 8 pumps. If the element <code>xAuto</code> of the structured data type <code>stMode</code> is set to TRUE, the pump is available for automatic mode. With another setting of this element, the respective pump is not available. Refer to the structured data type description (see page 157).

The table describes the input variables to the function block:

Input	Data Type	Description
i_xRele	BOOL	Activates (TRUE) or stops (FALSE) the execution of the function block.
i_siNuPump	SINT	Defines the number of installed pumps. Range: 1...8
i_astSta_Ex	ARRAY [0..7] of stSta	Array of stSta. Contains the external status information from 8 pumps. Refer to the structured data type description (see page 158).

The table describes the output variable from the function block:

Output	Data Type	Description
q_stAvai	stAvai	Structure that indicates the availability for a maximum of 8 pumps. Refer to the structured data type description (see page 156).
q_xAlrt	BOOL	If TRUE, the boolean output pin indicates that no pump with available state = TRUE is detected.

Section 1.10

VsdAvai: VSD Available Status

Overview

This section describes the `VsdAvai` function block for indicating the availability of a maximum of 8 VSDs.

NOTE: This function block is designed to be used in conjunction with other function blocks of the Pumping Library.

What Is in This Section?

This section contains the following topics:

Topic	Page
Description - <code>VsdAvai</code>	102
Function Block Description - <code>VsdAvai</code>	103

Description - VsdAvai

Overview

The `VsdAvai` function block indicates the availability of a maximum of 8 VSDs by processing the inputs of the individual VSDs.

The inputs processed by the function block may include:

- the physical state (power OK)
- the mode of the VSD (automatic or manual mode)
- a detected alarm state (for example, no response)
- a detected hardware error (for example, motor circuit breaker tripped)
- a detected connection loss between the controller and distributed I/O modules that may be involved in detecting the status of the VSD

Function Block Description - VsdAvai

Pin Diagram

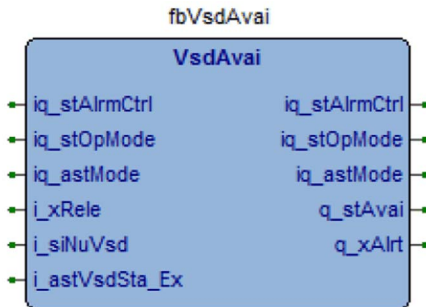

Brief Description

The `VsdAvai` function block verifies the status and the operating modes of a maximum of 8 VSDs to indicate their availability to the other function blocks.

I/O Variables Description

The table describes the input/output variables of the function block:

Input/Output	Data Type	Description
iq_stAlarmCtrl	stAlarmCtrl	Structure used for alarm handling. Refer to the structured data type description (see page 154).
iq_stOpMode	stOpMode	Determines the operating modes. If the element <code>xAuto</code> of the structured data type <code>stOpMode</code> is set to TRUE, the function block executes its tasks automatically. With another status of this element, the outputs of this function block are set to their defined fallback (default) states. Refer to the structured data type description (see page 155).
iq_astMode	ARRAY [0..7] of stMode	Array of <code>stMode</code> to control and switch the operating mode of the 8 VSDs. If the element <code>xAuto</code> of the structured data type <code>stMode</code> is set to TRUE, the VSD is available for automatic mode. With another setting of this element, the respective VSD is not available. Refer to the structured data type description (see page 157).

The table describes the input variables to the function block:

Input	Data Type	Description
i_xRele	BOOL	Activates (TRUE) or stops (FALSE) the execution of the function block.
i_siNuVsd	SINT	Defines the number of installed VSDs. Range: 1...8
i_astVsdSta_Ex	ARRAY [0..7] of stVsdSta	Array of stVsdSta. Contains the extern status information from 8 VSDs. Refer to the structured data type description (see page 159).

The table describes the output variable from the function block:

Output	Data Type	Description
q_stAvai	stAvai	Structure that indicates the availability for a maximum of 8 VSDs. Refer to the structured data type description (see page 156).
q_xAlrt	BOOL	If TRUE, the boolean output pin indicates that no VSD with available state = TRUE is detected.

Section 1.11

OpPrty: Operation Priority Device

Overview

This section describes the `OpPrty` function block for assigning a priority to the VSDs or pumps.

The function block can process 2 different types of priority:

- the operating hours of each VSD or pump in order to help to keep the number of operating hours at relatively the same level for the different VSDs / pumps,
- a user-defined priority table that allows you to define preferences for the different VSDs / pumps.

NOTE: This function block is designed to be used in conjunction with other function blocks of the Pumping Library.

What Is in This Section?

This section contains the following topics:

Topic	Page
Description - <code>OpPrty</code>	106
Function Block Description - <code>OpPrty</code>	108
Structured Data Type Definitions - <code>OpPrty</code>	110

Description - OpPrty

Overview

The `OpPrty` function block is used to assign a priority to the different VSDs or pumps available in your system.

NOTE: It sets the priority of a functional homogenous set of pumps and VSDs. You would need one instance of this function block for VS pumps / VSDs and one instance of this function block for FS pumps, if any.

The function block can process 2 different types of priority:

- The operating hours of each pump to help balance the operating hours between pumps / VSDs.
- A user-defined priority table that allows you to define your own preferences for the different pumps / VSDs.

Assigning a Priority According to the Operating Hours

The graphic shows an example of the priority assignment to devices (pumps or VSDs) according to their operating hours:

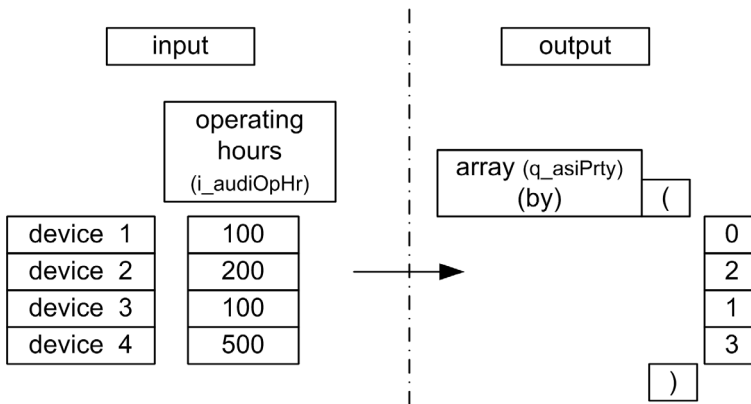

To activate this type of priority assignment, set the input parameter `i_ePrtyMode` to the value `Op`.

The `OpPrty` function block evaluates the operating hour values provided as input `i_audiOpHr` by the function blocks `FsPumpCtrl`, `VsPumpCtrl` and `VsdCtrl` to assign a priority to the pumps or VSDs.

The devices (pumps or VSDs) are arranged in their order of priority, with the highest priority being at the top of the output array table. The numbers of the output array `q_asiPrty` directly point to the respective pump or VSD (used as an index into an array of structures). This list starts with 0, which results in device 1 being assigned array index 0, and so on.

In case of identical operating hour values for 2 devices, the device that is on a higher place in the input table is also placed higher in the output table. This is illustrated in the graphic. Devices 1 and 3 both have a value of 100 operating hours. In the output table, they are on place 1 (device 1 --> array index 0) and place 2 (device 3 --> array index 1).

Assigning a Priority According to User-Defined Inputs

The graphic shows an example of the priority assignment to pumps according to a priority table that is configured by the operator:

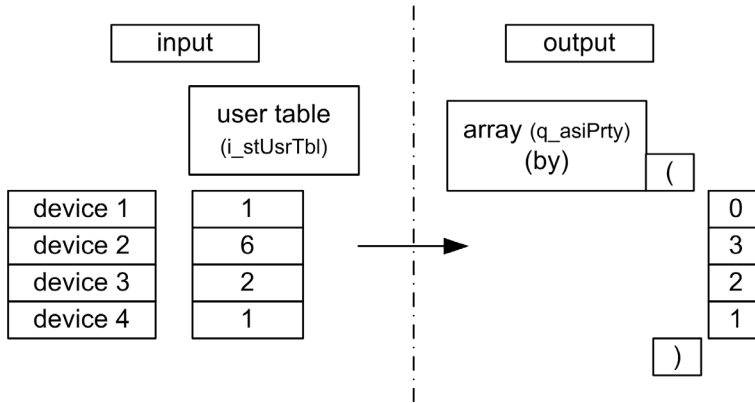

To activate this type of priority assignment, set the input parameter `i_ePrtyMode` to the value `User`.

The `OpPrty` function block assigns the priority to the VSDs and pumps according to the values provided as input `i_stUsrTbl` by the operator.

The devices (pumps or VSDs) are arranged in their order of priority, with the highest priority being at the top of the output array table. The numbers of the output array `q_asiPrty` directly point to the respective pump or VSD (used as an index into an array of structures). This list starts with 0, which results in device 1 being assigned array index 0, and so on.

In case of identical values for 2 devices, the device that is on a higher place in the input table is also placed higher in the output table. This is illustrated in the graphic. Devices 1 and 4 are both assigned priority 1 by the operator. In the output table, they are on places 1 (device 1 --> array index 0) and 2 (device 4 --> array index 1).

Function Block Description - OpPrty

Pin Diagram

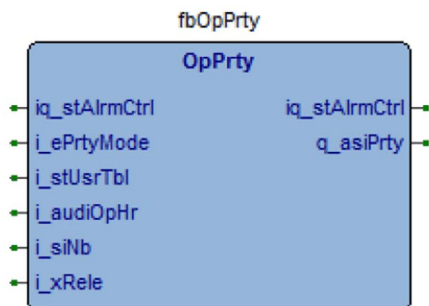

Brief Description

The OpPrty function block is used to assign a priority to the different pumps or VSDs available in a system.

The function block can process 2 different types of priority:

- the operating hours of each VSD or pump in order to help to keep the number of operating hours at relatively the same level for the different VSDs / pumps,
- a user-defined priority table that allows you to define preferences for the different VSDs / pumps.

I/O Variables Description

The table describes the input/output variable of the function block:

Input/Output	Data Type	Description
iq_stAlrmCtrl	stAlrmCtrl	Structure used for alarm handling. Refer to the structured data type description (see page 154).

The table describes the input variables to the function block:

Input	Data Type	Description
i_xRele	BOOL	Activates (TRUE) or stops (FALSE) the execution of the function block.
i_siNb	SINT	Defines the number of pumps or VSDs that are installed in the system. Range: 1...8

Input	Data Type	Description
i_audiOpHr	ARRAY [0..3] of UDINT	This array is a table listing the operating hours of the pumps or VSDs (maximum of 8). The operating hour values are provided by the following function blocks: <ul style="list-style-type: none"> ● FsPumpCtrl for FS pumps (see page 71) ● VsPumpCtrl for VS pumps (see page 66) ● VsdCtrl for VSDs (see page 62)
i_stUsrTbl	stUsrTbl	The user-defined priority table is defined as input. Refer to the structured data type description (see page 110).
i_ePrtyMode	ePrtyMode	Defines the type of priority that is used. Range: <ul style="list-style-type: none"> ● ePrtyMode.Op (=0) ● ePrtyMode.User (=1) Refer to the structured data type description (see page 154).

The table describes the output variable from the function block:

Output	Data Type	Description
q_asiPrty	ARRAY [0..8] of SINT	This array is a table listing the pumps or VSDs in the order according to the calculated priority. Refer to the structured data type description (see page 164).

Structured Data Type Definitions - OpPrty

Overview

Structured data types serve as the major input and output data carriers between different function blocks, configuration, and parameterization data.

The following section lists the names of structures (data types) that are used in this function block, followed by a table that describes the elements of structure.

NOTE: For the structured data types that are used from this function block and others, refer to the Common Structured Data Type Definitions chapter ([see page 154](#)).

Structure: stUsrTbl

The `stUsrTbl` structured data type contains the user-defined priority table. It allows you to assign a priority value to each of the 8 pumps or VSDs:

Element of <code>stUsrTbl</code>	Data Type	Description
<code>siDev1Prty</code>	SINT	Defines the priority value for VSD 1 or pump 1.
...
<code>siDev8Prty</code>	SINT	Defines the priority value for VSD 8 or pump 8.

Enumeration: ePrtyMode

The enumeration `ePrtyMode` data type is used to define the type of priority that is used.

Enumeration of <code>ePrtyMode</code>	Data Type	Description
Op	UDINT	<p>The priority is assigned to the pumps or VSDs according to the operating hours.</p> <p>The operating hour values are provided via the parameter <code>audiOpHr</code> by the following function blocks:</p> <ul style="list-style-type: none"> • <code>FsPumpCtrl</code> for FS pumps (see page 71) • <code>VsPumpCtrl</code> for VS pumps (see page 66) • <code>VsdCtrl</code> for VSDs (see page 62) <p>Value: 0</p>
User	UDINT	<p>The priority is assigned to the pumps or VSDs according to the user table.</p> <p>The priority values for the different pumps or VSDs are defined by the operator via the parameter <code>i_stUsrTbl</code>.</p> <p>Value: 1</p>

Section 1.12

AuxPumpCtrl: Auxiliary Pump Control

Overview

This section describes the `AuxPumpCtrl` function block for controlling and switching an auxiliary pump. The auxiliary pump is used in times of low demand (for example at night time) to maintain the pressure within a certain pressure range without using the main pumps.

NOTE: This function block is designed to be used in conjunction with other function blocks of the Pumping Library.

What Is in This Section?

This section contains the following topics:

Topic	Page
Description - <code>AuxPumpCtrl</code>	112
Function Block Description - <code>AuxPumpCtrl</code>	116
Structured Data Type Definitions - <code>AuxPumpCtrl</code>	119

Description - AuxPumpCtrl

Overview

The `AuxPumpCtrl` function block controls and switches the auxiliary pump in times of low demand (for example at night time).

If the demand of water is low and the last main pump is running, the `PumpPidStag` function block (see page 23) increases the pressure setpoint to a value that corresponds to the average of the working range of the auxiliary pump. When this pressure is reached, the `PumpPidStag` function changes the mode to sleep mode by setting the stage value to zero and the `iq_stOpMode.xSle` flag bit to TRUE (1). The result is that the main pumps are stopped. The auxiliary pump is working only in sleep mode to maintain the pressure within a certain pressure range avoiding to use the main pumps.

To maintain the pressure within the limits defined for sleep mode, the `AuxPumpCtrl` function block switches on or off the auxiliary pump. Additionally, the `AuxPumpCtrl` function block contains a flow limit and a pressure limit that allow to switch off the sleep mode and to return to operation of the main pumps if the demand rises.

Prerequisite

The `AuxPumpCtrl` function block executes its tasks only if the following conditions apply:

- The auxiliary pumping application is running on demand during the sleep mode.
The sleep mode is established by the `PumpPidStag` function block (see page 23) setting the element of the structured data type `iq_stOpMode.xSle` to TRUE (for more information refer to the chapter Common Structured Data Type Definitions (see page 155)).
With another setting of the `stOpMode` element `xSle` of the structured data type `iq_stOpMode`, the `AuxPumpCtrl` function block is disabled and the function block outputs are set to the default value (0 and FALSE).
- The alarm release bit `xAlrmRele` of the structured data type `stAlrmCtrl` (see page 154) is set to TRUE, indicating that no alarm has been detected in the pump group.
If the alarm release bit `xAlrmRele` is set to FALSE (0), the `AuxPumpCtrl` function block is disabled and the function block outputs are set to the default value (0 and FALSE).

Auxiliary Pump Control with Reset of Sleep Mode Using the Flow Value

The graphic shows the switch procedures of the `AuxPumpCtrl` function block during sleep mode and the reset of the sleep mode with the help of the flow value:

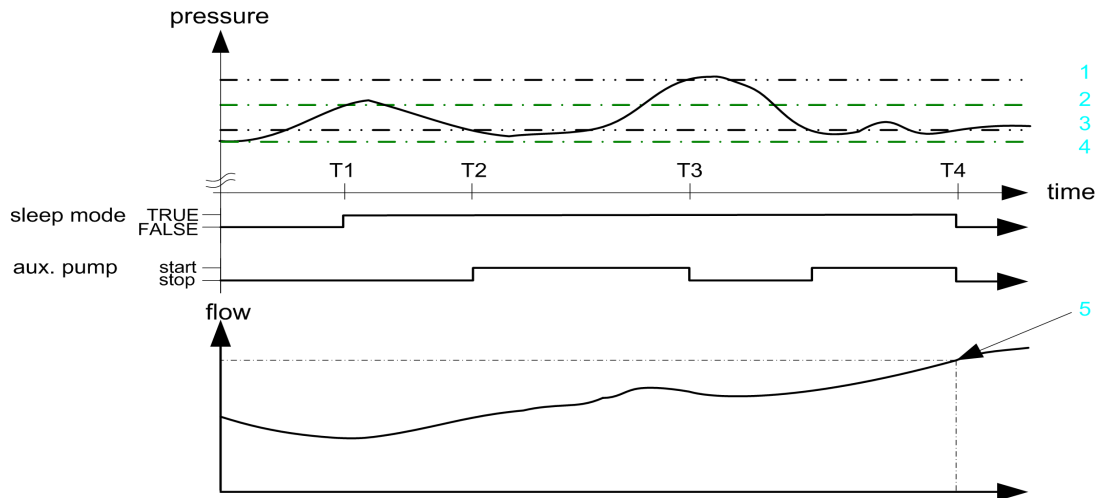

- 1 OFF limit for auxiliary pump (`rPresAuxLimOff`)
- 2 ON limit for sleep mode (defined in `PumpPidStag` function block (`irSP + stStagInit.rPresIncPump1SwcOff`))
- 3 ON limit for auxiliary pump (`rPresAuxLimOn`)
- 4 OFF limit by pressure for sleep mode (`rPresSleOff`) (not used in this graphic)
- 5 OFF limit by flow for sleep mode (`rFlowSleOff`)

The auxiliary pump control process consists of the following stages when the sleep mode is reset with the help of the flow value:

Stage (Time)	Description
1 (T1)	The <code>PumpPidStag</code> function block (see page 23) detects a low flow situation and sets the operating mode to sleep mode. Result: The <code>AuxPumpCtrl</code> function block is activated and monitors the pressure and the flow values.
2 (T2)	As soon as the pressure value drops below the user-defined ON limit for the auxiliary pump (<code>rPresAuxLimOn</code>), the auxiliary pump is set to the ON state.
3 (T3)	As soon as the pressure value rises above the OFF limit for the auxiliary pump (<code>rPresAuxLimOff</code>), the auxiliary pump is set to the OFF state.
4 (T4)	If the flow value rises above the user-defined OFF limit by flow for sleep mode (<code>rFlowSleOff</code>), the <code>AuxPumpCtrl</code> function block executes the following actions: <ul style="list-style-type: none"> ● setting the sleep mode <code>iq_stOpMode.xSle</code> to FALSE (0) ● setting the outputs to the default values (0 and FALSE)

Auxiliary Pump Control with Reset of Sleep Mode Using the Pressure Value

The graphic shows the switch procedures of the `AuxPumpCtrl` function block during sleep mode and the reset of the sleep mode with the help of the pressure value:

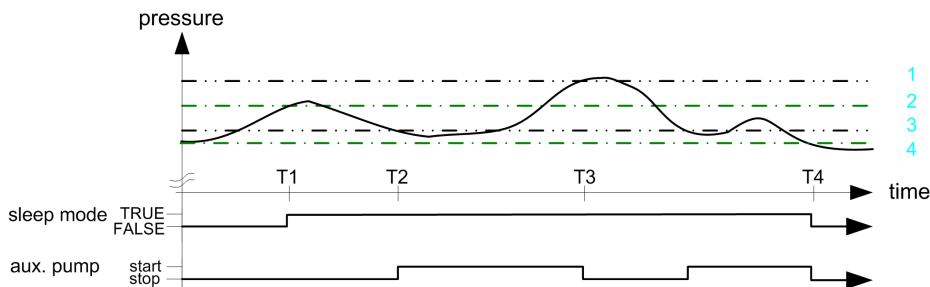

- 1 OFF limit for auxiliary pump (`iq_stAuxPumpCtrlInit.rPresAuxLimOff`)
- 2 ON limit for sleep mode (defined in `PumpPidStag` function block (`i_rSp + stStagInit.rPresIncPump1SwcOff`))
- 3 ON limit for auxiliary pump (`iq_stAuxPumpCtrlInit.rPresAuxLimOn`)
- 4 OFF limit by pressure for sleep mode (`iq_stAuxPumpCtrlInit.rPresSleOff`)

The auxiliary pump control process consists of the following stages when the sleep mode is reset with the help of the pressure value:

Stage (Time)	Description
1 (T1)	The <code>PumpPidStag</code> function block (see page 23) sets the operating mode to sleep mode. Result: The <code>AuxPumpCtrl</code> function block is activated and monitors the pressure value.
2 (T2)	As soon as the pressure value drops below the user-defined ON limit for the auxiliary pump (<code>iq_stAuxPumpCtrlInit.rPresAuxLimOn</code>), the auxiliary pump is set to the ON state.
3 (T3)	As soon as the pressure value rises above the OFF limit for the auxiliary pump (<code>iq_stAuxPumpCtrlInit.rPresAuxLimOff</code>), the auxiliary pump is set to the OFF state.
4 (T4)	If the pressure value falls below the user-defined OFF limit by pressure for sleep mode (<code>rPresSleOff</code>), the <code>AuxPumpCtrl</code> function block executes the following actions: <ul style="list-style-type: none"> ● setting the sleep mode to FALSE (<code>iq_stOpMode.xSle = FALSE (0)</code>) ● setting the outputs to the default values (0 and FALSE)

Reset of Sleep Mode by the PumpPidStag function block

The PumpPidStag function block ([see page 23](#)) can also stop the sleep mode.

If the PumpPidStag function block detects that the stage function switches a main pump into run state, the function block sets the element `xSle` of `iq_stopMode` to FALSE (0). This deactivation of the sleep mode is detected by the AuxPumpCtrl function block. It stops processing variables and sets the outputs to the default values (0 and FALSE).

Function Block Description - AuxPumpCtrl

Pin Diagram

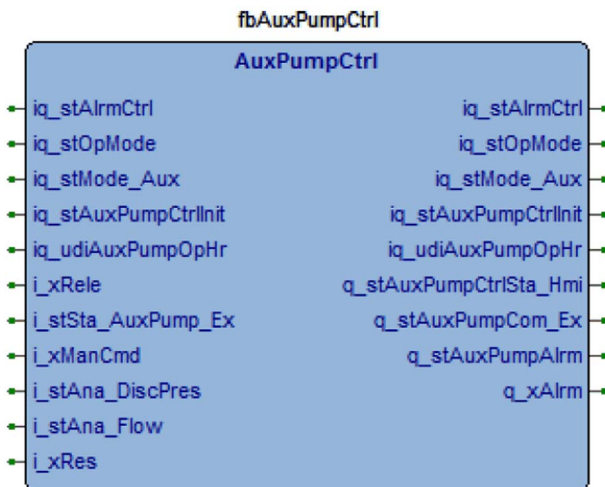

Brief Description

The `AuxPumpCtrl` function block is used for controlling and switching the auxiliary pump in times of low demand (during sleep mode) to avoid using the main pumps.

I/O Variables Description

Structure used for alarm handling. Refer to the structured data type description ([see page 154](#)).

The table describes the input/output variables of the function block:

Input/Output	Data Type	Description
<code>iq_stAlrmCtrl</code>	<code>stAlrmCtrl</code>	Structure used for alarm handling. Refer to the structured data type description (see page 154).
<code>iq_stOpMode</code>	<code>stOpMode</code>	Determines the operating modes. If the element <code>xSle</code> of the structured data type <code>stOpMode</code> is set to TRUE, the function block executes its tasks. With another setting of this element, the outputs of this function block are set to their defined fallback (default) states. Refer to the structured data type description (see page 155).

Input/Output	Data Type	Description
iq_stMode_Aux	stMode	Structure for the mode states to control and switch the operating mode of the auxiliary pump. Refer to the structured data type description (see page 157) .
iq_stAux_PumpCtrlInit	stAuxPumpCtrlInit	Structure used for initialization data for the auxiliary pump. Refer to the structured data type description (see page 119) .
iq_udiAuxPumpOpHr	UDINT	Lists the operating hours of the auxiliary pump. This input/output variable can be reset or adjusted even from HMI or SCADA systems.

The table describes the input variables to the function block:

Input	Data Type	Description
i_xRele	i.param	Activates (TRUE) or stops (FALSE) the execution of the function block.
i_stSta_AuxPump_Ex	stSta	Structure that contains the status of the auxiliary pump. Refer to the structured data type description (see page 158) .
i_xManCmd	BOOL	When TRUE, commands the start of the auxiliary pump.
i_stAna_DiscPres	stAna	Structure that contains the discharge pressure and its status. Refer to the structured data type description (see page 156) .
i_stAna_Flow	stAna	Structure that contains the flow input value and its status. Refer to the structured data Type description (see page 156) .
i_xRes	BOOL	Resets alarms detected in the auxiliary pump when the cause has been corrected.

The table describes the output variables from the function block:

Output	Data Type	Description
q_stAuxPumpCtrlSta_Hmi	stAuxPumpCtrlSta	Structure is used to display the status of the auxiliary pump on the HMI. Refer to the structured data Type description (see page 120).
q_stAuxPumpCom_Ex	stAuxPumpCom	Structure that is used to activate the auxiliary pump. Refer to the structured data Type description (see page 161).
q_stAuxPumpAlrm	stAuxPumpAlrm	Structure is used to indicate alarm states of the auxiliary pump. Refer to the structured data Type description (see page 120).
q_xAlrm	BOOL	Alarm flag.

Structured Data Type Definitions - AuxPumpCtrl

Overview

Structured data types serve as the major input and output data carriers between different function blocks, configuration, and parameterization data.

The following section lists the names of structures (data types) that are used in this function block, followed by a table that describes the elements of structure.

NOTE: For the structured data types that are used from this function block and others, refer to the Common Structured Data Type Definitions chapter ([see page 154](#)).

Structure: stAuxPumpCtrlInit

The stAuxPumpCtrlInit structured data type contains the initialization data for the AuxPumpCtrl function block.

Element of stAuxPumpCtrlInit	Data Type	Description
rFlowSleOff	REAL	Contains the OFF limit by flow for the sleep mode. If this flow value is reached, the sleep mode variable iq_stOpMode.xSle is set to FALSE by the AuxPumpCtrl function block.
rPresSleOff	REAL	Contains the OFF limit by pressure for the sleep mode. If this pressure value is reached, the sleep mode variable iq_stOpMode.xSle is set to FALSE by the AuxPumpCtrl function block.
rPresAuxLimOn	REAL	Contains the ON limit by pressure for the auxiliary pump. If this pressure value is reached, the AuxPumpCtrl function block starts the auxiliary pump to keep the pressure value within the pressure range allowed during sleep mode.
rPresAuxLimOff	REAL	Contains the OFF limit by pressure for the auxiliary pump. If this pressure value is reached, the AuxPumpCtrl function block stops the auxiliary pump.

Element of <code>stAuxPumpCtrlInit</code>	Data Type	Description
<code>tFbckDel</code>	TIME	Defines the time allowed for the auxiliary pump to send a response. Range: $tFbckDel > T > 0$ s As soon as the command is not equal to the response message received from the auxiliary pump, the delay timer of the feedback alarm is started. If the time elapses without receiving a response message equal to the command, an alarm is detected.
<code>tMinTime</code>	TIME	Defines the minimum time the auxiliary pump has to be running before it can be switched off again. This time span is also used as minimum stop time (time the auxiliary pump has to be in stop state before it can be switched on again).

NOTE: Thoroughly test all functions during verification and commissioning.

Structure: `stAuxPumpCtrlSta`

The `stAuxPumpCtrlSta` structured data type displays the status of the auxiliary pump on the HMI.

Element of <code>stAuxPumpCtrlSta</code>	Data Type	Description
<code>xAuxPumpAct</code>	BOOL	When TRUE, the auxiliary pump is active.
<code>xSleAct</code>	BOOL	When TRUE, the sleep mode is active.
<code>xSleInt</code>	BOOL	When TRUE, the <code>AuxPumpCtrl</code> function block has set the sleep mode to OFF because it has detected that the flow is above the allowed limit or the pressure is below the allowed limit.

Structure: `stAuxPumpAlrm`

The `stAuxPumpAlrm` output structured data type is used to indicate the detected alarm states.

Element of <code>stAuxPumpAlrm</code>	Data Type	Description
<code>xParaVal</code>	BOOL	When TRUE, a configuration error has been detected.
<code>xStaErr</code>	BOOL	When TRUE, a hardware error of the auxiliary pump has been detected.
<code>xFbck</code>	BOOL	When TRUE, a feedback error has been detected because no response has been received from the auxiliary pump within the defined feedback time.

Section 1.13

PipeFill: Pipe Fill Control

Overview

This section describes the `PipeFill` function block for verifying the pressure in the pipes.

After a start or a restart of the pumping application, it starts specific processes to reach the pressure working range as quickly as possible.

During operation, it constantly monitors whether the pressure level is within the working range. If the pressure level is higher or lower than the working range, the function block generates an alarm after a certain delay time.

NOTE: This function block is designed to be used in conjunction with other function blocks of the Pumping Library.

What Is in This Section?

This section contains the following topics:

Topic	Page
Description - <code>PipeFill</code>	122
Function Block Description - <code>PipeFill</code>	126
Structured Data Type Definitions - <code>PipeFill</code>	128

Description - PipeFill

Overview

The PipeFill function block verifies the pressure in the pipe of the discharge side.

After start or restart of the pumping application, it verifies the discharge pressure value. If the pressure is not within the working range (user-defined pressure setpoint $i_rSp \pm$ the setpoint tolerance range $iq_stFillInit.rTnce$), it starts the adequate procedure to reach the working range of the pressure by using a systematic process.

During normal operation, the PipeFill function block constantly monitors whether the pressure level is within the working range. If the pressure level is higher or lower than the working range for a certain delay time, the function block indicates the detected alarm.

Actions After Start / Restart of the Pumping Application

After a start / restart of the pumping application, the PipeFill function block verifies whether the pressure in the discharge pipe is within the working range.

Depending on the discharge pressure value, the function block reacts differently:

If...	Then the PipeFill function block
the discharge pressure is within the working range	<ul style="list-style-type: none"> ● indicates that the pressure is OK by setting the input/output value <code>iq_stOpMode.xFillOk</code> to TRUE. ● continues to verify the pressure value as described in the paragraph <i>Actions during Normal Operation</i> (see page 125).
the discharge pressure is below the working range	<ul style="list-style-type: none"> ● sets the input/output value <code>iq_stOpMode.xFill</code> to TRUE to indicate that the pipe fill function is in progress. ● starts the adequate sequence (sequence 1 (see page 123) or sequence 2 (see page 124)) of the pipe fill procedure to reach the working range of the pressure as quickly as possible.

The procedure to reach the working range of the pressure is divided in 2 different sequences. It depends on the discharge pressure value which sequence is started.

The diagram shows the pressure setpoint values for the 2 sequences and their influences on the pressure in the pumping application:

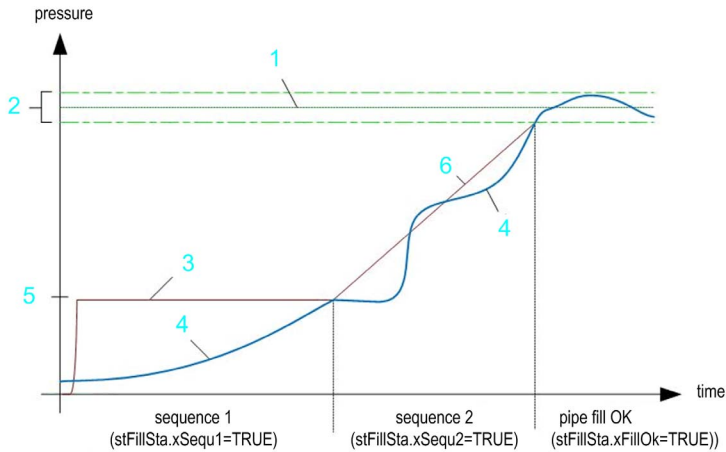

- 1 user-defined pressure setpoint value (i_rSp)
- 2 pressure working range (that is the allowed deviation ($iq_stFillInit.rTnce$) from the user-defined pressure setpoint value (i_rSp))
- 3 minimal startup discharge pressure limit ($stFillInit.rFillPres$)
- 4 present discharge pressure of this pressure zone
- 5 minimal startup discharge pressure limit ($iq_stFillInit.rFillPres$). If the pressure is below this limit, sequence 1 is started. If the pressure is above this limit and not in the working range (2), then sequence 2 of the pipe fill procedure is started.
- 6 The setpoint is constantly incremented and provided to the PID control unit. After the working range has been reached, the user-defined pressure setpoint value (1) is used by the PID control unit.

Sequence 1 of the Start / Restart Procedure

Sequence 1 of the pipe fill procedure is started, if the pressure value is between 0 and the pipe fill pressure ($iq_stFillInit.rFillPres$, item 5 in the diagram).

Actions executed during sequence 1

Step	Description
1	The operating mode is set to pipe fill mode ($iq_stOpMode.xFill$) to TRUE to indicate the mode to the other function blocks of the pumping application.
2	A timer (defined with the parameter $iq_stFillInit.tSeq1$) is started with the start of sequence 1.
3	The output value $iq_stOpMode.xFill$ is set to TRUE to indicate that the pipe fill function is in progress.

Step	Description
4	The output value <code>q_stFillStat.xSequ1</code> is set to TRUE to indicate that the pipe fill function is running in sequence 1. Result: The 2 outputs <code>iq_stOpMode.xFill</code> and <code>iq_stFillInit.xSequ1</code> are read by the <code>PumpPidStag</code> function block. If they are both set to TRUE, then the <code>PumpPidStag</code> function block detects that sequence 1 of the pipe fill function is running.
5	The <code>PumpPidStag</code> function block (<i>see page 23</i>) initiates the start of a fixed number of pumps with a fixed speed (configured for this sequence 1 of the pipe fill case with the parameter <code>iq_stFillDevInit.byNoPump</code>).
6	The <code>PumpPidStag</code> function block stops PID control by setting <code>q_stPidSta.xStopActv</code> to TRUE because it is not used in sequence 1.
7	If the discharge pressure reaches the pipe fill pressure limit (item 5 in the previous diagram) within the time allowed for sequence 1 (<code>iq_stFillInit.tSequ1</code>), then sequence 2 starts. If the timer expires and the pipe fill pressure is not reached, the <code>PipeFill</code> function block executes the following actions: <ul style="list-style-type: none"> ● It indicates a detected alarm (by setting the output <code>q_stFillAlrm.xSequTimeOut</code> to TRUE). ● It sets the outputs to the default values (0 and FALSE). ● It sets the operating mode to manual mode.

Sequence 2 of the Start / Restart Procedure

Sequence 2 of the pipe fill procedure is started if the discharge pressure value is higher than the pipe fill pressure limit (item 5 in the previous diagram) but lower than the working pressure range (item 2 in the diagram).

Actions executed during sequence 2

Step	Description
1	The operating mode is set to pipe fill mode (<code>iq_stOpMode.xFill</code>) to indicate the mode to the other function blocks of the pumping application.
2	A timer (defined with the parameter <code>iq_stFillInit.tSequ2</code>) is started with the start of sequence 2.
3	The <code>PipeFill</code> function block uses the pressure as the start up value for the setpoint value at the output <code>q_stSpAdap.rVal</code> .
4	The output value <code>q_stFillStat.xSequ2</code> is set to TRUE to indicate that the pipe fill function is running in sequence 2. Result: <code>iq_stOpMode.xFill</code> and <code>iq_stFillInit.xSequ2</code> are read by the <code>PumpPidStag</code> function block. If they are both set to TRUE, then the <code>PumpPidStag</code> function block detects that sequence 2 of the pipe fill function is running.
5	The <code>PumpPidStag</code> function block starts PID control by setting <code>q_stPidSta.xStopActv</code> to FALSE.

Step	Description
6	The <code>PipeFill</code> function block automatically increases the pressure setpoint in a ramp until the pressure reaches the working pressure range.
7	<p>If the working pressure range (item 2 in the previous diagram) is reached within the time allowed for sequence 2 (<code>iq_stFillInit.tSequ2</code>), the <code>PipeFill</code> function block indicates that the pressure is OK by setting the input/ output value <code>iq_stOpMode.xFillOk</code> to TRUE. It continues to verify the pressure value as described in the paragraph <i>Actions during Normal Operation</i>.</p> <p>If the pressure working range is not reached within the defined time, the <code>PipeFill</code> function block executes the following actions:</p> <ul style="list-style-type: none"> • It indicates a detected alarm (by setting the output <code>q_stFillAlrm.xSequ2TimeOut</code> to TRUE). • It sets the outputs to the default values (0 and FALSE). • It sets the operating mode to manual mode (<code>iq_stOpMode.xMan</code>).

Actions during Normal Operation

During normal operation, the `PipeFill` function block constantly monitors whether the discharge pressure value is within the working pressure range (setpoint influenced by other functions during operation $i_rSpAct \pm$ the setpoint tolerance range `iq_stFillInit.rTnce`).

If...	Then the <code>PipeFill</code> function block
the pressure level is higher than the working range for a certain delay time (<code>iq_stFillInit.tPresAlrmDel</code>)	indicates a detected alarm by setting the output <code>q_stFillAlrm.xHighPres</code> to TRUE
the pressure level is lower than the working range for a certain delay time (<code>iq_stFillInit.tPresAlrmDel</code>)	indicates a detected alarm by setting the output <code>q_stFillAlrm.xLowPres</code> to TRUE

If an alarm is detected, the `PipeFill` function block executes the following actions:

- It sets the outputs to the default values (0 and FALSE).
- It sets the operating mode to manual mode.

Function Block Description - PipeFill

Pin Diagram

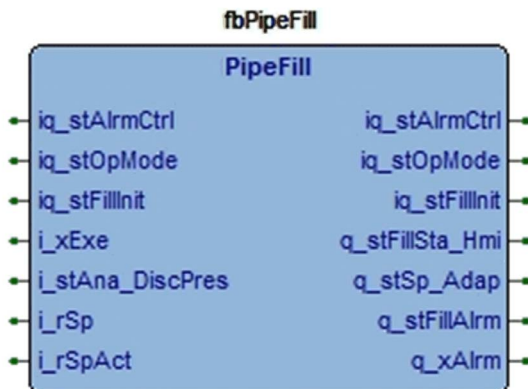

Brief Description

The `PipeFill` function block verifies the discharge pressure in the discharge pipe to help to reach the working pressure range of the pressure quickly after start or restart of the pumping application. During normal operation, it generates an alarm if it detects that the pressure level is higher or lower than the working range for a certain time.

I/O Variables Description

The table describes the input/output variables of the function block:

Input/Output	Data Type	Description
iq_stAlarmCtrl	stAlarmCtrl	Structure used for alarm handling. Refer to the structured data type description (see page 154).
iq_stOpMode	stOpMode	Determines the operating modes. If the element <code>xAuto</code> of the structured data type <code>stOpMode</code> is set to TRUE, the function block executes its tasks automatically. With another status of this element, the outputs of this function block are set to their defined fallback (default) states. Refer to the structured data type description (see page 155).
iq_stFillInit	stFillInit	Structure used for initialization data. Refer to the structured data type description (see page 128).

The table describes the input variables to the function block:

Input	Data Type	Description
i_xExe	BOOL	Input from the operator to start the pipe fill mode manually. When TRUE, the pipe fill mode is started.
i_stAna_DiscPres	stAna	Structure used for the analog input value containing the discharge pressure and the state of this value. Refer to the structured data type description (see page 156).
i_rSp	REAL	Contains the user-defined pressure setpoint which can be adapted by other functions, like compensation functions (see page 74) using the flow value from flow meter, if available (see page 81) or the cavitation protection function (see page 88).
i_rSpAct	REAL	Contains the adapted pressure setpoint that is influenced by other functions, like compensation functions (see page 74) (using the flow value from the flow meter, if available (see page 81)) or the cavitation protection function (see page 88). The value is constantly adjusted to the situation of the pumping application.

The table describes the output variables from the function block:

Output	Data Type	Description
q_stFillSta_Hmi	stFillStat	Structure that is used to display the status of the pipe fill function on the HMI. Refer to the structured data type description (see page 162).
q_stSp_Adap	stSp	Structure that contains the adjusted pressure value. This is the user-defined pressure setpoint that has been corrected by the pipe fill function. Refer to the structured data type description (see page 163).
q_stFillAlrm	stFillAlrm	Structure that indicates the alarm states detected in pipe fill mode. Refer to the structured data type description (see page 130).
q_xAlrm	BOOL	Alarm flag.

Structured Data Type Definitions - PipeFill

Overview

Structured data types serve as the major input and output data carriers between different function blocks, configuration, and parameterization data.

The following section lists the names of structures (data types) that are used in this function block, followed by a table that describes the elements of structure.

NOTE: For the structured data types that are used from this function block and others, refer to the Common Structured Data Type Definitions chapter ([see page 154](#)).

Structure: stFillInit

The stFillInit structured data type contains the initialization data for the PipeFill function block.

Element of stFillInit	Data Type	Description
rFillPres	REAL	This pipe fill pressure value (legend item 5 in the overview diagram of the start / restart procedure) (see page 122) is dedicated to the startup or restart procedure. It defines the pressure level that has to be reached to change from the first startup sequence to the second startup sequence. The second startup sequence uses the PumpPidStag function block (see page 23).
tSequ1	UDINT	Defines the time allowed for the first startup sequence. Range: tSequ1 > 0 ms A timer is started when the PipeFill function block starts sequence 1. If the time defined with this parameter expires without reaching the pressure level defined with the parameter rFillPres, then the PipeFill function block indicates that an alarm has been detected. This is achieved by setting the output q_stFillAlrm.xSequ1Timeout to TRUE (see page 130).

Element of <code>stFillInit</code>	Data Type	Description
<code>tSequ2</code>	UDINT	<p>Defines the time allowed for the second startup sequence.</p> <p>Range: <code>tSequ2 > 0 ms</code></p> <p>A timer is started when the <code>PipeFill</code> function block starts sequence 2.</p> <p>If the time defined with this parameter expires without reaching the pressure working range (defined with the parameter <code>i_rSP</code> and the tolerance <code>rTnce</code>), then the <code>PipeFill</code> function block indicates that an alarm has been detected. This is achieved by setting the output <code>q_stFillAlrm.xSequ2Timeout</code> to TRUE (see page 130).</p>
<code>rTn</code>	REAL	<p>Defines the stage time (T_n, in milliseconds) for the reference ramp during PID controlling in the second startup sequence.</p> <p>Range: <code>rTn > 0.0 ms</code></p> <p>The time required to increase the pressure value by 1 unit.</p>
<code>rTnce</code>	REAL	<p>Defines the tolerance range. The tolerance is a \pm value in %. It defines the range that the pressure may deviate from the user-defined pressure setpoint value (<code>i_rSP</code>). No detected alarm is indicated as long as the pressure is within this range.</p> <p>Range: <code>10 > rTnce \geq 0</code></p> <p>Default value: 5 (allowing a deviation of 5% from the pressure setpoint value (<code>i_rSP</code>))</p>
<code>tPresAlrmDel</code>	UDINT	<p>Defines the time the pressure value has to be continuously out of the tolerance range before a detected alarm is indicated on the alarm output.</p> <p>Range: <code>tPresAlrmDel > 3000ms</code></p> <p>Default value: 30000ms</p>

NOTE: The elements of the structure are set to the default values (0 or FALSE) assigned by the controller on system startup.

Structure: stFillAlrm

The stFillAlrm structured data type is used to indicate the alarm states detected in pipe fill mode.

Element of stFillAlrm	Data Type	Description
xSequ1TimeOut	BOOL	When TRUE, a timeout has been detected in sequence 1 of the pipe fill mode.
xSequ2TimeOut	BOOL	When TRUE, a timeout has been detected in sequence 2 of the pipe fill mode.
xDiscPresSta	BOOL	When TRUE, the discharge pressure value is not available.
xLowPres	BOOL	When TRUE, it has been detected that the pressure has been lower than the defined working range for the delay time defined with stFillInit.tPresAlrmDel.
xHighPres	BOOL	When TRUE, it has been detected that the pressure has been higher than the defined working range for the delay time defined with stFillInit.tPresAlrmDel.

Section 1.14

OpIntPump: Operator Interface for Pump Handling

Overview

This section describes the `OpIntPump` function block representing the operator interface to the functions of this library.

If the pumping application is running in manual mode, the operator can directly modify the configuration parameters.

NOTE: This function block is designed to be used in conjunction with other function blocks of the Pumping Library.

What Is in This Section?

This section contains the following topics:

Topic	Page
Description - <code>OpIntPump</code>	132
Function Block Description - <code>OpIntPump</code>	135
Structured Data Type Definitions - <code>OpIntPump</code>	140

Description - OpIntPump

Overview

The `OpIntPump` function block allows the operator to influence the pumping application via inputs on an HMI terminal. This application function block represents the interface from the pump application to the potential HMI. The handling and the architecture of the HMI application is not part of this document.

The figure illustrates the different inputs and outputs of the `OpIntPump` function block:

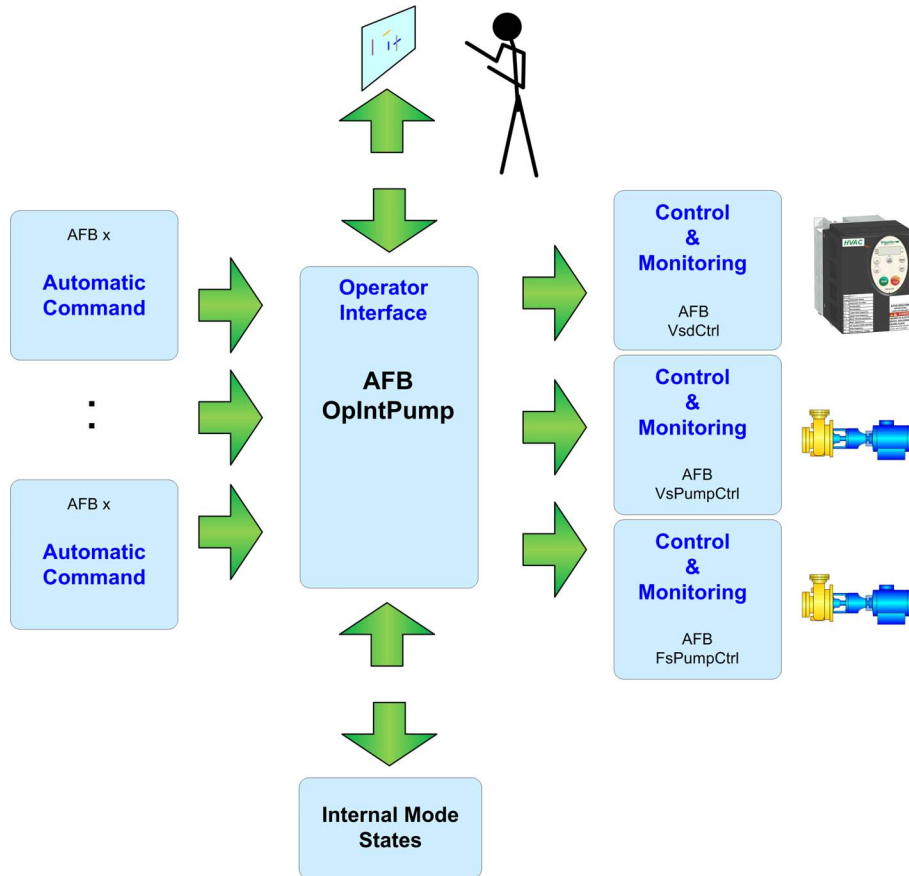

The `OpIntPump` function block executes the following tasks:

- It detects states and modes of the individual pumps, VSDs, and of the pumping application.
- It transforms states and modes of the individual pumps, VSDs, of the pump group, and of the pumping system into short integer values. This helps to save configuration times when assigning HMI symbols. During operation, it helps to optimize communication exchanges.
- It receives automatic commands for the VSDs, pumps, and for the auxiliary pump. If the pumping application is running in automatic mode, it forwards these commands consecutively to the outputs.
- It receives operator commands from the HMI and forwards them if the pumping application is running in automatic mode.
- It verifies the operating mode of the pumping application:
 - If it is running in manual mode, then it accepts only the commands from the HMI.
 - If it is running in automatic mode, then it accepts only the internal commands.
- When a pump or VSD is in hand or maintenance mode and is subsequently released, the `OpIntPump` function block reassigns the previous mode that was valid in the pumping application for this device.
- It allows the operator to assign the control of the application to a local or a remote HMI.

The graphic illustrates the relationship between the input and output pins of the `OpIntPump` function block and the information provided on the HMI.

HMI

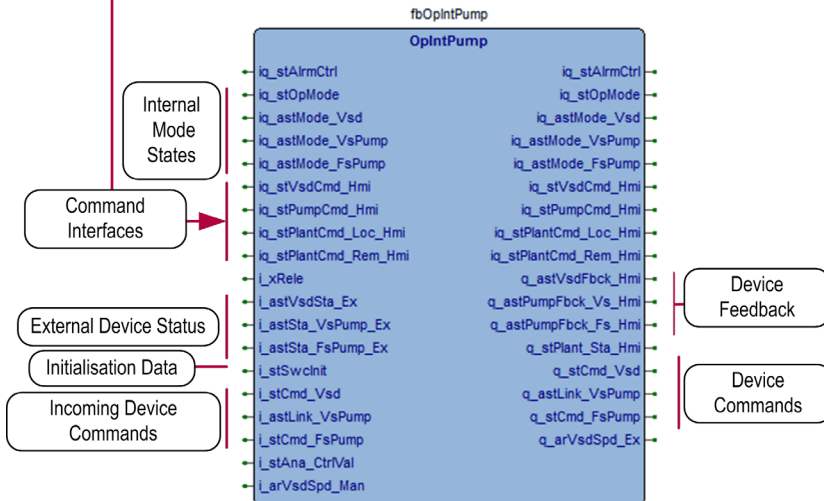
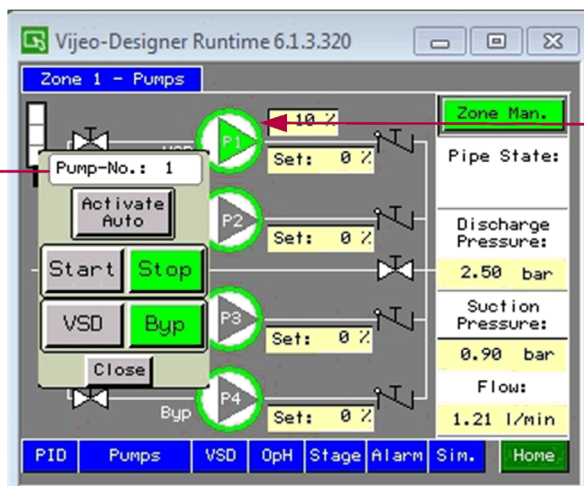

Function Block Description - OpIntPump

Pin Diagram

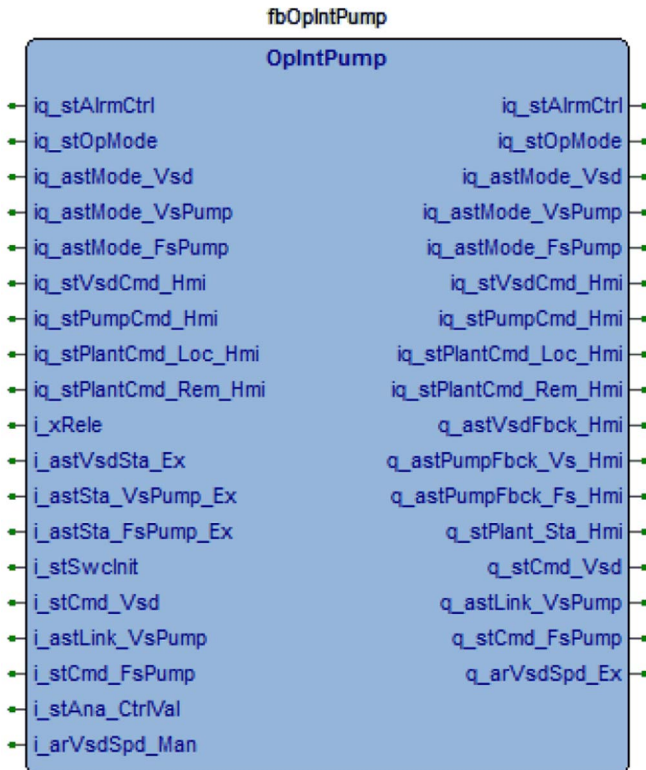

Brief Description

The OpIntPump function block allows the operator to influence the pumping application via inputs on an HMI terminal.

I/O Variables Description

The table describes the input/output variables of the function block:

Input/Output	Data Type	Description
iq_stAlrmCtrl	stAlrmCtrl	Structure used for alarm handling. Refer to the structured data type description (see page 154).
iq_stOpMode	stOpMode	<p>Determines the operating modes.</p> <p>If this structured data type is set to <code>xMan</code>, the function block accepts and executes commands entered by the operator. Automatic commands are rejected.</p> <p>If this structured data type is set to <code>xAuto</code>, the function block verifies whether an error has been detected. If not, it forwards the commands consecutively to the output pins.</p> <p>If an error has been detected, (<code>iq_stOpMode.xAlrm</code>) the outputs of this function block are set to their defined fallback (default) states. Refer to the structured data type description (see page 155).</p>
iq_astMode_Vsd	ARRAY [0..7] of stMode	Array of <code>stMode</code> to control and switch the operating mode of the VSDs (maximum of 8). Refer to the structured data type description (see page 157).
iq_astMode_VsPump	ARRAY [0..7] of stMode	Array of <code>stMode</code> to control and switch the operating mode of the VS pumps (maximum of 8). Refer to the structured data type description (see page 157).
iq_astMode_FsPump	ARRAY [0..7] of stMode	Array of <code>stMode</code> to control and switch the operating mode of the FS pumps (maximum of 8). Refer to the structured data type description (see page 157).
iq_stVsdCmd_Hmi	stVsdCmd	Structure used to control and switch the states of the VSDs. Refer to the structured data type description (see page 140).
iq_stPumpCmd_Hmi	stPumpCmd	Structure used to control and switch the states of the main pumps. Refer to the structured data type description (see page 140).

Input/Output	Data Type	Description
iq_stPlantCmd_Loc_Hmi	stPlantCmd	Structure used to control and switch the states of the machine application. This input/output variable is useful to control and switch the state of several pump groups from one local HMI. Refer to the structured data type description (see page 141) .
iq_stPlantCmd_Rem_Hmi	stPlantCmd	Structure used to control and switch the states of the machine application. This input/output variable is useful to control and switch the state of several pump groups from one remote HMI. Refer to the structured data type description (see page 141) .

The table describes the input variables to the function block:

Input	Data Type	Description
i_xRele	BOOL	Activates (TRUE) or stops (FALSE) the execution of the function block.
i_astVsdSta_Ex	ARRAY [0..7] of stVsdSta	Array of stVsdSta. Contains the external status information from 8 VSDs. Refer to the structured data type description (see page 159) .
i_astSta_VsPump_Ex	ARRAY [0..7] of stSta	Array of stSta. Contains the external status information from 8 VS pumps. Refer to the structured data type description (see page 158) .
i_astSta_FsPump_Ex	ARRAY [0..7] of stSta	Array of stSta. Contains the external status information from 8 FS pumps. Refer to the structured data type description (see page 158) .
i_stSwcInit	stSwcInit	The structure contains the number of pumps installed. Refer to the structured data type description (see page 48) .
i_stCmd_Vsd	stCmd	Structure used for switching the FS pumps into run state (maximum of 8). Refer to the structured data type description (see page 157) .
i_astLink_VsPump	ARRAY [0..7] of stLink	Array of stLink to link the VS pumps (maximum of 8) dynamically or constantly to one of the VSDs, or directly to the power source (direct online) by using contactors. Refer to the structured data Type description (see page 160) .

Input	Data Type	Description
i_stCmd_FsPump	stCmd	Array of stCmd for switching the FS pumps (maximum of 8) into run state. Refer to the structured data Type description (see page 157).
i_stAna_CtrlVal	stAna	Structure that indicates the PID control value and the state of this value. Refer to the structured data Type description (see page 161).
i_arVsdSpd_Man	ARRAY [0..7] of REAL	The array of REAL contains the manual speed values of the VSDs (0..7).

The table describes the output variables from the function block:

Output	Data Type	Description
q_astVsdFbck_Hmi	ARRAY [0..7] of stVsdFbck	Array that is used to display the status and the modes of the VSDs (maximum of 8) on the HMI. Refer to the structured data type description (see page 143).
q_astPumpFbck_Vs_Hmi	ARRAY [0..7] of stPumpFbck	Array that is used to display the status and the modes of the VS pumps (maximum of 8) on the HMI. Refer to the structured data type description (see page 143).
q_astPumpFbck_Fs_Hmi	ARRAY [0..7] of stPumpFbck	Array that is used to display the status and the modes of the FS pumps (maximum of 8) on the HMI. Refer to the structured data type description (see page 143).
q_stPlant_Sta_Hmi	stPlant	Structure that is used to display the status and the mode of the machine application on the HMI. Refer to the structured data type description (see page 144).
q_stCmd_Vsd	stCmd	Structure that is used for switching the VS pumps into run state (maximum of 8). Refer to the structured data type description (see page 143).
q_astLink_VsPump	ARRAY [0..7] of stLink	Array of stLink to link the VS pumps (maximum of 8) dynamically or constantly to one of the VSDs, or directly to the power source (direct online) by using contactors. Refer to the structured data type description (see page 160).

Output	Data Type	Description
q_stCmd_FsPump_Ex	stCmd	Structure used for switching the FS pumps into run state (maximum of 8). Refer to the structured data type description (see page 157).
q_arVsdSpd_Ex	ARRAY [0..7] of REAL	Contains the speed values for the VSDs (maximum of 8) in percent.

Structured Data Type Definitions - OpIntPump

Overview

Structured data types serve as the major input and output data carriers between different function blocks, configuration, and parameterization data.

The following section lists the names of structures (data types) that are used in this function block, followed by a table that describes the elements of structure.

NOTE: For the structured data types that are used from this function block and others, refer to the Common Structured Data Type Definitions chapter ([see page 154](#)).

Structure: stVsdCmd

The stVsdCmd structured data type is used to control and switch the states of the VSDs.

Element of stVsdCmd	Data Type	Description
siNb	SINT	Defines the number of VSDs that are available in the system. Range: 1..8
xAutoMode	BOOL	automatic mode When TRUE, the VSD is running in automatic mode without user intervention.
xManMode	BOOL	manual mode When TRUE, the VSD is running in manual mode, that means it is controlled by operator inputs.
xMainMode	BOOL	maintenance mode When TRUE, the VSD is running in maintenance mode and is not available for the application.

Structure: stPumpCmd

The stPumpCmd structured data type is used to control and switch the states of the pumps. It is available if the pumping application is running in manual mode (stOpMode.xMan = TRUE).

Element of stPumpCmd	Data Type	Description
siNb	SINT	Indicates the number of the pump on which the commands will be executed. Range: 1..8
eCmdType	UDINT / Enumeration	1 = FixSpeed 2 = VariSpeed
xAutoMode	BOOL	When TRUE, the pump is switched to automatic mode.
xManMode	BOOL	When TRUE, the pump is switched to manual mode.

Element of <code>stPumpCmd</code>	Data Type	Description
<code>xMainMode</code>	BOOL	When TRUE, the pump is switched to maintenance mode.
<code>xStrt</code>	BOOL	When TRUE, the pump is switched into run state.
<code>xStop</code>	BOOL	When TRUE, the pump is switched into stop state.
<code>xByps</code>	BOOL	Used if fixed link operational mode is selected. When TRUE, the bypass contactor of the corresponding pump is selected (direct online mode).
<code>xVsd</code>	BOOL	Used if fixed link operational mode is selected. When TRUE, the contactor of the corresponding pump to link the VSD is selected.

The following table provides an example of the settings that must be set at the HMI to switch pump 1 to run state:

Element of <code>stPumpCmd</code>	Value	Description	Type of Action
<code>siNb</code>	1	number of the pump	selection
<code>xAutoMode</code>	–	automatic mode	command
<code>xManMode</code>	–	manual mode	command
<code>xMainMode</code>	–	maintenance mode	command
<code>xStrt</code>	TRUE	start	command
<code>xStop</code>	–	stop	command
<code>xByps</code>	–	bypass	command
<code>xVsd</code>	–	VSD mode	command

Structure: `stPlantCmd`

The `OpIntPump` function block uses the `stPlantCmd` structured data type as an input/output variable. The structure is used to control and switch the states of the machine application. This variable is used if there is a local and a remote HMI configured for controlling the pumping application.

The remote HMI control allows you to remotely monitor the application, to perform various maintenance activities, including modifications to data and configuration parameters, and to change the state of the application and associated hardware. Strict care must be taken to be sure that the immediate physical environment of the machine is in a state that will not present safety risks to people or property before exercising control remotely.

NOTE: The documentation of the programming, in particular the parametrization of the HMI, is not part of this document.

WARNING

UNINTENDED EQUIPMENT OPERATION

- Configure and install the mechanism that enables the remote HMI local to the machine, so that local control over the machine can be maintained regardless of the remote commands sent to the application.
- Have a complete understanding of the application and the machine before attempting to control the application remotely.
- Take the precautions necessary to assure that you are operating remotely on the intended machine by having clear, identifying documentation within the application and its remote connection.

Failure to follow these instructions can result in death, serious injury, or equipment damage.

Element of <code>stPlantCmd</code>	Data Type	Description
<code>xRem</code>	BOOL	Command: switch to remote mode When TRUE, the <code>OpIntPump</code> function block switches the operating mode <code>stOpMode.xRem</code> to TRUE.
<code>xLoc</code>	BOOL	Command: switch to local mode When TRUE, the <code>OpIntPump</code> function block switches the operating mode <code>stOpMode.xAuto</code> to TRUE.
<code>xAuto</code>	BOOL	Command: switch to automatic mode When TRUE, the <code>OpIntPump</code> function block switches the operating mode <code>stOpMode.xLoc</code> to TRUE.
<code>xMan</code>	BOOL	Command: switch to manual mode When TRUE, the <code>OpIntPump</code> function block switches the operating mode <code>stOpMode.xMan</code> to TRUE.

See the related output variable `stPlant`.

Structure: stVsdFbck

The `OpIntPump` function block uses the `stVsdFbck` structured data type as an output variable. The `stVsdFbck` structured data type contains status bits designed to represent the status and mode of related VSDs on the HMI (for example, by using different colors to represent different states or modes).

Element of <code>stVsdFbck</code>	Data Type	Description
<code>siSta</code>	SINT	Indicates the status of a specific VSD. Range: Bit 0 = stop Bit 1 = run Bit 2 = alert detected Bit 3 = alarm detected Bit 4 = maintenance
<code>siMode</code>	SINT	Indicates the mode of a specific VSD. Range: Bit 0 = manual mode Bit 1 = automatic mode Bit 2 = maintenance mode

Structure: stPumpFbck

The `stPumpFbck` structured data type contains status bits designed to represent the status and mode of related pumps on the HMI (for example, by using different colors to represent different states or modes).

Element of <code>stPumpFbck</code>	Data Type	Description
<code>siSta</code>	SINT	Indicates the status of a specific pump. Range: Bit 0 = stop Bit 1 = run Bit 2 = alert detected Bit 3 = alarm detected Bit 4 = maintenance
<code>siMode</code>	SINT	Indicates the mode of a specific pump. Range: Bit 0 = manual mode Bit 1 = automatic mode Bit 2 = maintenance mode

Element of <code>stPumpFbck</code>	Data Type	Description
<code>siVsdNu</code>	SINT	Indicates which VSD is serving the VS pump. Range: Bit 0 = not used Bit 1 = VSD1 (with flexible operational mode enabled) Bit 2 = VSD2 (with flexible operational mode enabled) Bit 3 = VSD3 (with flexible operational mode enabled) Bit 4 = VSD4 (with flexible operational mode enabled) Bit 5 = bypass option is enabled Bit 6 = VSD is set to run state (with fixed link operational mode enabled)
<code>siType</code>	SINT	Indicates the type of a specific pump. Range: Bit 0 = VS pump bypassing the VSD or FS pump Bit 1 = VS pump

Structure: `stPlant`

The `stPlant` structured data type is used to indicate the status and the mode of the machine application on the HMI.

Element of <code>stPlant</code>	Data Type	Description
<code>siMode</code>	SINT	Indicates the mode of the machine application. Range: Bit 0 = controlled by remote HMI Bit 1 = controlled by local HMI
<code>siGrpMode</code>	SINT	Indicates the operating mode of the pump group. Range: Bit 0 = manual mode Bit 1 = automatic mode

Section 1.15

OpIntAuxPump: Auxiliary Pump Operator Interface Function

Overview

This section describes the OpIntAuxPump function block representing the operator interface to the functions of this library.

If the pumping application is running in manual mode, the operator can directly modify the run state.

NOTE: This function block is designed to be used in conjunction with other function blocks of the Pumping Library.

What Is in This Section?

This section contains the following topics:

Topic	Page
Description - OpIntAuxPump	146
Function Block Description - OpIntAuxPump	149
Structured Data Type Definitions - OpIntAuxPump	151

Description - OpIntAuxPump

Overview

The OpIntAuxPump function block allows the operator to influence the pumping application via inputs on an HMI terminal. This application function block represents the interface from the pump application to the potential HMI. The handling and the architecture of the HMI application is not part of this document.

The figure illustrates the different inputs and outputs of the OpIntAuxPump function block:

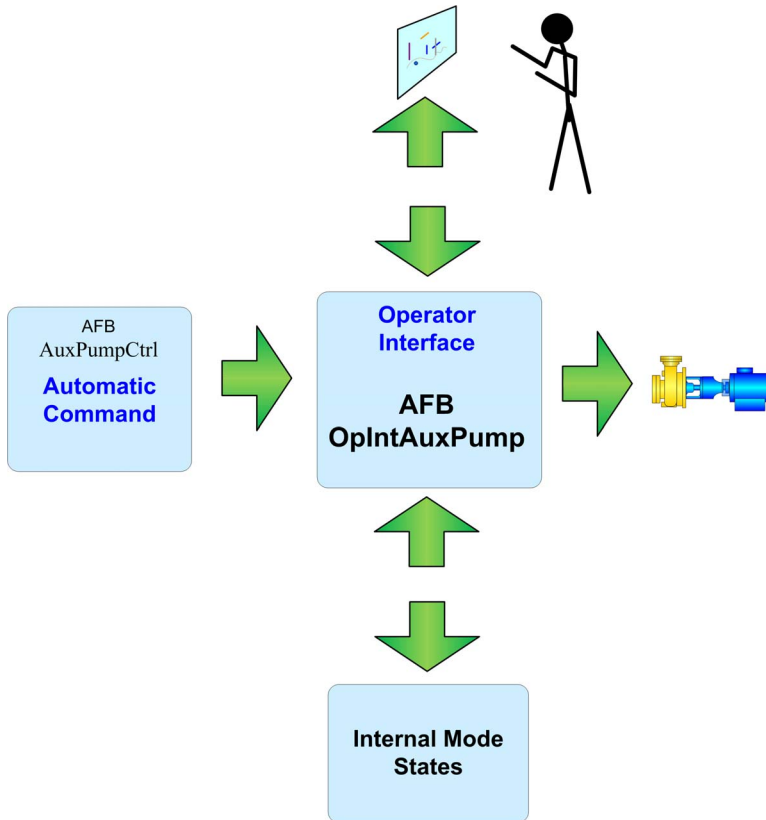

The `OpIntAuxPump` function block executes the following tasks:

- It detects states and modes of the auxiliary pump.
- It transforms the state and the mode of the auxiliary pump into short integer values. This helps to save configuration times when assigning HMI symbols. During operation, it helps to optimize communication exchanges.
- It receives automatic commands for the auxiliary pump. If the pumping application is running in automatic mode, it forwards these commands consecutively to the output.
- It receives operator commands from the HMI and forwards them if the pumping application is running in manual mode.
- It verifies the operating mode of the pumping application:
 - If it is running in manual mode, then it accepts only the commands from the HMI.
 - If it is running in automatic mode, then it accepts only the controller commands.
- When the auxiliary pump is in hand or maintenance mode and is subsequently released, the `OpIntAuxPump` function block reassigns the previous mode that was valid in the pumping application for this device.
- It allows the operator to assign the control of the application to a local or a remote HMI.

The graphic illustrates the relationship between the input and output pins of the `OpIntAuxPump` function block and the information provided on the HMI.

HMI

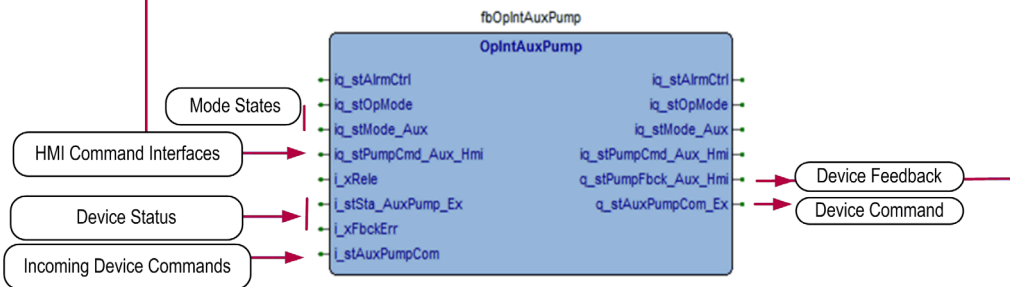
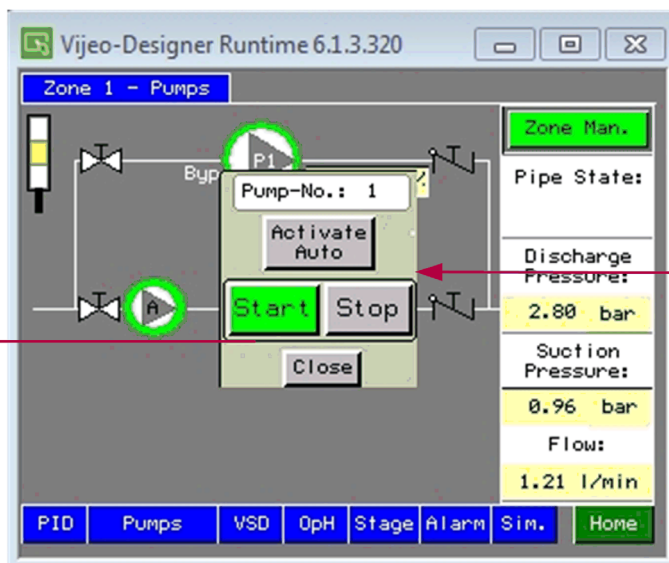

Function Block Description - OpIntAuxPump

Pin Diagram

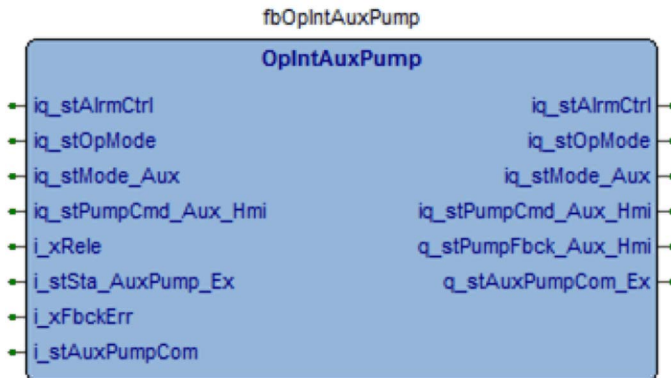

Brief Description

The `OpIntAuxPump` function block allows the operator to influence the auxiliary pump via inputs on an HMI terminal.

I/O Variables Description

The table describes the input/output variables of the function block:

Input/Output	Data Type	Description
iq_stAlarmCtrl	stAlarmCtrl	Structure used for alarm handling. Refer to the structured data type description (see page 154).
iq_stOpMode	stOpMode	Determines the operating modes. If this structured data type is set to <code>xMan</code> , the function block accepts and executes commands entered by the operator. Automatic commands are rejected. If this structured data type is set to <code>xAuto</code> , the function block verifies whether an error has been detected. If not, it forwards the commands consecutively to the output pins. If an error has been detected (<code>iq_stOpMode.xAlarm</code>), the outputs of this function block are set to their defined fallback (default) states. Refer to the structured data type description (see page 155).

Input/Output	Data Type	Description
iq_stMode_Aux	stMode	Structure to control and switch the operating mode of the auxiliary pump. Refer to the structured data type description (see page 157).
iq_stPumpCmd_Aux_Hmi	stPumpCmd	Structure used to control and switch the states of the auxiliary pump. Refer to the structured data type description (see page 140).

The table describes the input variables to the function block:

Input	Data Type	Description
i_xRele	BOOL	Activates (TRUE) or stops (FALSE) the execution of the function block.
i_stSta_AuxPumpEx	stSta	Structure that contains the status of the auxiliary pump. Refer to the structured data type description (see page 158).
i_xFbckErr	BOOL	This pin is linked to the feedback error, detected by the <code>AuxPumpCtrl</code> function block (see page 116).
i_stAuxPumpCom	stAuxPumpCom	The structure contains the command bit for the auxiliary pump inclusive of the state. If the state bit is set to TRUE the command bit is valid. Refer to the structured data type description (see page 153).

The table describes the output variables from the function block:

Output	Data Type	Description
q_stPumpFbck_Aux_Hmi	stPumpFbck	The structure <code>stPumpFbck</code> is used to display the status and the modes of the auxiliary pump. Refer to the structured data type description (see page 152).
q_stAuxPumpCom_Ex	stAuxPumpCom	The structure contains the command bit for the auxiliary pump inclusive of the state. If the state bit is set to TRUE the command bit is valid. Refer to the structured data type description (see page 153).

Structured Data Type Definitions - OpIntAuxPump

Overview

Structured data types serve as the major input and output data carriers between different function blocks, configuration, and parameterization data.

The following section lists the names of structures (data types) that are used in this function block, followed by a table that describes the elements of structure.

NOTE: For the structured data types that are used from this function block and others, refer to the Common Structured Data Type Definitions chapter ([see page 154](#)).

Structure: stPumpCmd

The stPumpCmd structured data type is used to control and switch the states of the pumps. This structure is used as a command interface from the OpIntAuxPump function block..

Element of stPumpCmd	Data Type	Description
siNb	SINT	Indicates the number of the pump on which the commands will be executed. Range: 1...4
ID	SINT	Constant = 1
xAutoMode	BOOL	When TRUE, the pump is switched to automatic mode.
xManMode	BOOL	When TRUE, the pump is switched to manual mode.
xMainMode	BOOL	When TRUE, the pump is switched to maintenance mode.
xStrt	BOOL	When TRUE, the pump is switched into run state.
xStop	BOOL	When TRUE, the pump is switched into stop state.
xByps	BOOL	Reserved.
xVsd	BOOL	Reserved.
rManSp	BOOL	Reserved.

The following table provides an example of the settings that must be set at the HMI to switch pump 1 to run state:

Element of stPumpCmd	Value	Description	Type of Action
siNb	1	number of the pump	selection
ID	1	constant	selection
xAutoMode	–	automatic mode	command
xManMode	–	manual mode	command
xMainMode	–	maintenance mode	command

Element of <code>stPumpCmd</code>	Value	Description	Type of Action
<code>xStrt</code>	TRUE	start	command
<code>xStop</code>	–	stop	command
<code>xByps</code>	–	bypass	command
<code>xVsd</code>	–	VSD mode	command

Structure: `stPumpFbck`

The `stPumpFbck` structured data type contains status bits designed to represent the status and mode of related pumps on the HMI (for example, by using different colors to represent different states or modes).

Element of <code>stPumpFbck</code>	Data Type	Description
<code>siSta</code>	SINT	Indicates the status of a specific pump. Range: Bit 0 = stop Bit 1 = run Bit 2 = alert detected Bit 3 = alarm detected Bit 4 = maintenance
<code>siMode</code>	SINT	Indicates the mode of a specific pump. Range: Bit 0 = manual mode Bit 1 = automatic mode Bit 2 = maintenance mode
<code>siVsdNu</code>	SINT	Indicates which VSD is serving the VS pump. Range: Bit 0 = not used Bit 1 = VSD1 (with flexible operational mode enabled) Bit 2 = VSD2 (with flexible operational mode enabled) Bit 3 = VSD3 (with flexible operational mode enabled) Bit 4 = VSD4 (with flexible operational mode enabled) Bit 5 = bypass option is enabled Bit 6 = VSD is set to run state (with fixed link operational mode enabled)
<code>siType</code>	SINT	Indicates the operating mode of the pump group. Range: Bit 0 = manual mode Bit 1 = automatic mode

Structure: stAuxPumpCom

The `stAuxPumpCom` structured data type contains the command bit to run the auxiliary pump and its state:

Element of <code>stAuxPumpCom</code>	Data Type	Description
<code>stAuxPumpCom</code>	BOOL	This element contains the command bit to run the auxiliary pump.
<code>xSta</code>	BOOL	If the state bit <code>xSta</code> is set to TRUE the command bit is valid.

Section 1.16

Common Structured Data Type Definitions

Common Structured Data Type Definitions

Overview

Structured data types serve as the major input and output data carriers between different function blocks, conveying input, configuration, and parameterization data.

The following sections list the names of the structured data types that are used in several function blocks of this library, followed by a table that describes the internal parameters that populate the structure.

Structure: `stAlarmCtrl`

The alarm control structured data type is used to indicate a detected alarm within the pump group and to reset detected alarms.

Element of <code>stAlarmCtrl</code>	Data Type	Description
<code>xAlarmRele</code>	BOOL	When FALSE, an alarm has been detected. The functions set the outputs to the default state. If a function detects a system level alarm, then the function sets this bit to FALSE. The pump group is stopped.
<code>xRstAlarm</code>	BOOL	Resets the detected alarms. When set to TRUE, the alarm values are set to zero, when the cause has been corrected.

NOTE: This alarm control structured data type needs to be defined only once per pump in the system.

Structure: stOpMode

The `stOpMode` structured data type controls / switches the operating mode of the pumping application.

If a function block detects an alarm state in the pump group, this function block automatically sets the operating mode to manual mode. This is achieved by setting the structured data type `stOpMode` to `xAuto = FALSE` and `xMan = TRUE`. At the same time, the function block indicates that an alarm has been detected by setting `xAlrm` to `TRUE`. Operator intervention is required to change from manual mode to another operating mode and to acknowledge the detected alarm.

Element of <code>stOpMode</code>	Data Type	Description
<code>xAlrm</code>	BOOL	alarm mode When TRUE, indicates that an alarm has been detected in the pump group during data processing.
<code>xAuto</code>	BOOL	automatic mode When TRUE, the pumping application is working in automatic mode without user intervention.
<code>xMan</code>	BOOL	manual mode When TRUE, the pumping application is working in manual mode, which means it is controlled by user inputs.
<code>xFill</code>	BOOL	pipe fill mode When TRUE, the pumping application is working in pipe fill mode. After start or restart of the pumping application the pipe fill function starts specific processes (as defined with the <code>PipeFill</code> function block (see page 126)) to reach the pressure working range as quickly as possible.
<code>xCavtMarg</code>	BOOL	cavitation margin mode When TRUE, the suction pressure is below the cavitation margin and the pumping application is running in cavitation margin mode as defined with the <code>CavtProt</code> function block (see page 93).
<code>xCaviFlow</code>	BOOL	Reserved.
<code>xPidMan</code>	BOOL	PID manual mode When TRUE, the pumping application is running with a PID (proportional integral derivative) manual setpoint. This mode is set by the operator using the operator interface. In this mode, the <code>PumpPidStag</code> function block (see page 23) uses an alternative pressure setpoint manually entered by the operator.
<code>xPIDStop</code>	BOOL	PID stopped mode When TRUE, the PID has been stopped.

Element of <code>stOpMode</code>	Data Type	Description
<code>xPIDAuto</code>	BOOL	PID automatic mode When TRUE, the PID is running in automatic mode.
<code>xPrim</code>	BOOL	Reserved.
<code>xSle</code>	BOOL	sleep mode When TRUE, the pumping application is working in sleep mode in times of low water demand in order to avoid using the main pumps (VS pumps or FS pumps). The sleep mode is started by the <code>PumpPidStag</code> function block (see page 23). It is stopped either by the <code>PumpPidStag</code> function block or by the <code>AuxPumpCtrl</code> function block (see page 116).
<code>xRem</code>	BOOL	remote mode When TRUE, disables the local HMI and enables the remote HMI to control the application.
<code>xLoc</code>	BOOL	local mode When TRUE, disables the remote HMI and enables the local HMI to control the application.

NOTE: This alarm control structured data type needs to be defined only once per pump in the system.

Structure: `stAna`

The `stAna` structured data type is used for the analog input value from the pressure sensor (measuring the pressure) or the flow meter (measuring the flow).

Element of <code>stAna</code>	Data Type	Description
<code>rAnaVal</code>	REAL	Scaled (physical units) analog value. The pressure / suction pressure value used as an input by the <code>PipeFill</code> function block (see page 126) and <code>CavtProt</code> function block (see page 93).
<code>xStat</code>	BOOL	When TRUE, indicates that the value of <code>rAnaVal</code> is valid.

Structure: `stAvai`

The `stAvai` structured data type is used to indicate the availability of 8 devices. This variable is used for VSDs, VS pumps, and FS pumps.

Element of <code>stAvai</code>	Data Type	Description
<code>xAvai1</code>	BOOL	When TRUE, indicates that device 1 is available.
...
<code>xAvai8</code>	BOOL	When TRUE, indicates that device 8 is available.

Structure: stStagVal

The `stStagVal` structured data type contains the stage value and its state. The stage value represents the demand for the number of pumps which are needed to maintain the required pressure level.

Element of <code>stStagVal</code>	Data Type	Description
<code>siStag</code>	SINT	Indicates the number of pumps which are needed to maintain the required pressure level.
<code>xSta</code>	BOOL	When TRUE, indicates that no error has been detected in the pump.

Structure: stCmd

The `stCmd` structured data type is used to switch the 8 devices (VSDs or FS pumps) into run or stop state.

Element of <code>stCmd</code>	Data Type	Description
<code>xDev1</code>	BOOL	When TRUE, switches device 1 into run state.
...
<code>xDev8</code>	BOOL	When TRUE, switches device 8 into run state.

Structure: stMode

The `stMode` structured data type controls / switches the modes of the individual pumps and VSDs.

Element of <code>stMode</code>	Data Type	Description
<code>xRem</code>	BOOL	remote mode When TRUE, the pump is locked for control by an HMI at a remote station.
<code>xLoc</code>	BOOL	local mode When TRUE, the pump is locked for control by the local HMI.
<code>xHand</code>	BOOL	hand mode When TRUE, the pump is locked for inputs that are made directly at the pump. Any commands from HMIs are blocked.
<code>xMain</code>	BOOL	maintenance mode When TRUE, the pump is in maintenance mode and is not available for the application.
<code>xAuto</code>	BOOL	automatic mode When TRUE, the pump is operated in automatic mode without user intervention.
<code>xManu</code>	BOOL	manual mode When TRUE, the pump is controlled by user inputs.

Element of <i>stMode</i>	Data Type	Description
xVsd	BOOL	VSD mode When TRUE, the VS pump is fixed linked to a VSD.
xByps	BOOL	bypass When TRUE, the VS pump bypasses the VSD because the VSD, to which the VS pump had been linked, is not available.
xAlrm	BOOL	alarm mode When TRUE, an alarm has been detected in the pump.
xAlrt	BOOL	Reserved.

Structure: *stSta*

The *stSta* structured data type indicates the status of the individual pumps as indicated by external devices (key switches, sensors, contactors).

Element of <i>stSta</i>	Data Type	Description
xHandMod	BOOL	hand mode When TRUE, the pump has been locked for operation in hand mode by a key switch. It is not available for the pumping application.
xMain	BOOL	maintenance mode When TRUE, the pump has been locked for operation in maintenance mode by a key switch. It is not available for the pumping application.
xDryRun	BOOL	dry run When TRUE, a sensor has indicated that the pump is running dry. It is not available for the pumping application.
xTempAlrm	BOOL	high temperature When TRUE, a sensor has indicated that the temperature in the pump is too high. It is not available for the pumping application.
xErr	BOOL	hardware error detected When TRUE, a hardware error has been detected in the pump. It is not available for the pumping application.

Element of <i>stSta</i>	Data Type	Description
xLinkOk	BOOL	bus link OK When TRUE, the data connection to the distributed I/O hardware module which provides status information on the pump is available. In contrast to the other parameters, this parameter is by default set to TRUE. No error is detected if no distributed I/O hardware module is used in the application.
xRun	BOOL	pump run When TRUE, a contactor has indicated that the pump has been switched in run status.
xStop	BOOL	pump stop When TRUE, a contactor has indicated that the pump has been switched in stop status.

Structure: *stVsdSta*

The *stVsdSta* structured data type indicates the status of the individual VSDs as indicated by the VSD and/or external devices (key switches, sensors, contactors).

Element of <i>stVsdSta</i>	Data Type	Description
xPowerOk	BOOL	VSD power OK When TRUE, the power supply for the VSD is available. In contrast to the other parameters, this parameter is by default set to TRUE. No error is detected if no power supply detection is used in the application.
xLinkOk	BOOL	bus link OK When TRUE, the data connection to the distributed I/O hardware module which provides status information on the VSD is available. In contrast to the other parameters, this parameter is by default set to TRUE. No error is detected if no distributed I/O hardware module is used in the application.
xAlarm	BOOL	detected alarm state When TRUE, an alarm has been detected for the VSD. It is not available for the pumping application.
xRun	BOOL	VSD run When TRUE, indicates that the VSD is in run state.

Structure: stLink

The stLink structured data type is used to link one VS pump dynamically to one of the up to 8 possible VSDs or constantly to one of the 4 VSDs or directly to the power source (direct online) by switching the respective contactors (see examples below).

Element of stLink	Data Type	Description
xVsd1	BOOL	When TRUE, the VS pump is linked to VSD 1.
xVsd2	BOOL	When TRUE, the VS pump is linked to VSD 2.
xVsd3	BOOL	When TRUE, the VS pump is linked to VSD 3.
xVsd4	BOOL	When TRUE, the VS pump is linked to VSD 4.
xByp5	BOOL	When TRUE, the VS pump bypasses the VSD. In this mode, the VS pump is directly linked to the power source (direct online).
xRun	BOOL	When TRUE, the VS pump is constantly linked to a VSD. This is only used in fixed link operational mode.

Example of using the stLink structured data type with variable links (fixed link operational mode disabled):



Example of using the `stLink` structured data type with fixed links (fixed link operational mode enabled):



Structure: `stAuxPumpCom`

The `stAuxPumpCom` structured data type is used to switch the auxiliary pump. The structure contains a binary element to switch the auxiliary pump into run state and a binary element to indicate the status of this procedure.

Element of <code>stAuxPumpCom</code>	Data Type	Description
<code>xAuxPumpRunCom</code>	BOOL	When TRUE, the auxiliary pump is switched into run state.
<code>xSta</code>	BOOL	When TRUE, the <code>xAuxPumpRunCom</code> command is valid.

Structure: stFillStat

The stFillStat structured data type is used to indicate the state of the pipe fill function.

Element of stFillStat	Data Type	Description
xFill	BOOL	When TRUE, indicates that the pipe fill function is in progress.
xFillOk	BOOL	When TRUE, indicates that the pressure value has reached the defined working range. NOTE: If the pipe fill function is not used, the parameter stFillStat.xFillOk has to be set to TRUE to enable the PID and stage functions of the PumpPidStag function block (see page 23).
xSequ1	BOOL	When TRUE, the pipe fill function is running in sequence 1.
xSequ2	BOOL	When TRUE, the pipe fill function is running in sequence 2.
xAlrm	BOOL	alarm mode When TRUE, indicates that an alarm has been detected in the pipe fill function.

Structure: stCavtSta

The stCavtSta structured data type is used to indicate the state of the cavitation protection function.

Element of stCavtSta	Data Type	Description
xProtActv	BOOL	When TRUE, indicates that the cavitation protection function is in progress.
xSpRedu	BOOL	When TRUE, indicates that the setpoint of the control pressure has been reduced because the suction pressure is dropping.
xRstPos	BOOL	When TRUE, indicates that a reset of the cavitation alarm can be executed because the suction pressure is above the minimal setpoint value (legend item 5 in the diagram representing the working principle of the cavitation protection procedure (see page 88)).
xGdntPlus	BOOL	When TRUE, indicates that the suction pressure is rising (suction pressure gradient is positive).
xGdntMnus	BOOL	When TRUE, indicates that the suction pressure is dropping (suction pressure gradient is negative).

Structure: stSp

The `stSp` structured data type is used to indicate a setpoint value.

Element of <code>stSp</code>	Data Type	Description
<code>rVal</code>	REAL	Indicates a reference value.
<code>xsta</code>	BOOL	When TRUE, indicates that the value of <code>rVal</code> is valid.

Structure: stDeviceAlrm

The `stDeviceAlrm` structured data type is used to indicate detected errors of the (maximum 8) FS or VS pumps or VSDs.

Element of <code>stDeviceAlrm</code>	Data Type	Description
<code>xDev1Alrm</code>	BOOL	When TRUE, an error has been detected for pump 1 / VSD 1.
...
<code>xDev8Alrm</code>	BOOL	When TRUE, an error has been detected for pump 8 / VSD 8.

Structure: stRespErr

The `stRespErr` structured data type is used to indicate a detected error in the FS or VS pumps or VSDs (maximum of 8) because the time defined with the parameter `i_tDelFbck` has expired without receiving a response from the pump / VSD.

Element of <code>stRespErr</code>	Data Type	Description
<code>xDev1</code>	BOOL	When TRUE, an error has been detected for pump 1 / VSD 1 because no response has been received within the defined time.
...
<code>xDev8</code>	BOOL	When TRUE, an error has been detected for pump 8 / VSD 8 because no response has been received within the defined time.

Structure: abyVsdNu

The array of BYTE `abyVsdNu` is used to contain the number of the VSD associated with a given pump. The index to the array indicates the VS pump number.

Element of <code>abyVsdNu</code>	Data Type	Description
<code>abyVsdNu</code>	ARRAY [0..7] of BYTE	Defines the VSD numbers. Range: <ul style="list-style-type: none"> ● 0 = unused ● 1...4 = VSD numbers ● 5 = bypass ● 6 = run (fixed link operational mode)

Structure: asiPrty

The `asiPrty` is used to contain the priority assignment:

Element of <code>asiPrty</code>	Data Type	Description
<code>asiPrty</code>	ARRAY [0..7] of SINT	The array of short integer is used to list in sequence the priority of the VSDs or pumps as defined by the operating hours or by operator inputs: The VSD / pump that is the first in the list is assigned the highest priority.

Glossary



B

bypass

If a variable speed (VS) pump is operated without a variable speed drive (VSD), because there is no VSD available, it can bypass the VSD. For this, the pump is directly connected to the power source and its speed cannot be changed.

C

cavitation

The process of cavities being produced in a liquid due to rapid changes of pressure. The implosion of these *bubbles* in pumps may cause significant wear or may even damage them. This is why cavitation situations should be avoided for pumps.

F

fixed link operational mode

In this mode, each variable speed drive is constantly linked to 1 variable speed pump.

flexible operational mode

This mode of the pumping application is only available if there are no FS pumps configured and if the number of VS pumps is greater than the number of VSDs. The bypass option is enabled and the fixed link operational mode is disabled by software parameters. The flexible operational mode is the mode with the greatest availability of pumps because the VS pumps can be used independently of VSDs.

FS pump

(fixed speed pump) A pump that is directly connected to the power source. The speed of this pump cannot be changed.

H

HMI

(human machine interface) An operator interface (usually graphical) for human control over industrial equipment.

N

NPSH

(*net positive suction head*) The minimum pressure energy that has to be available at the entry point of a pump to help prevent the liquid from boiling and thus to help prevent acavitation situation.]]

The NPSH value is provided by manufacturers of pumps throughout Europe.]

The NPSH+ value is provided by manufacturers of pumps throughout the USA.

P

PID

(*proportional, integral, derivative*) A generic control loop feedback mechanism (controller) widely used in industrial control systems.

V

VS pump

(*variable speed pump*) A pump that is linked to a variable speed drive. The variable speed drive controls the speed of the pump.

VSD

(*variable speed drive*) An equipment that makes a variable and regulates the speed and rotational force, or torque output, of an electric motor.



A

AuxPumpCtrl
function block, 112

C

cavitation protection, 88
CavtProt
function block, 88
CompSp
function block, 74
CompSpFlow
function block, 81

D

DevSwcPumpCtrl
function block, 36

F

FsPumpCtrl
function block, 70
function block
AuxPumpCtrl, 112
CavtProt, 88
CompSp, 74
CompSpFlow, 81
DevSwcPumpCtrl, 36
FsPumpCtrl, 70
OpIntAuxPump, 146
OpIntPump, 132
OpPrty, 106
PipeFill, 122
PumpAvai, 98
PumpPidStag, 16
VsdAvai, 102
VsdCtrl, 61
VsPumpCtrl, 65

O

OpIntAuxPump
function block, 146
OpIntPump
function block, 132
OpPrty
function block, 106

P

PipeFill
function block, 122
PumpAvai
function block, 98
pumping
AuxPumpCtrl, 112
CavtProt, 88
CompSp, 74
CompSpFlow, 81
DevSwcPumpCtrl, 36
FsPumpCtrl, 70
OpIntAuxPump, 146
OpIntPump, 132
OpPrty, 106
PipeFill, 122
PumpAvai, 98
PumpPidStag, 16
VsdAvai, 102
VsdCtrl, 61
VsPumpCtrl, 65
PumpPidStag
function block, 16

V

- VsdAvai
 - function block, 102
- VsdCtrl
 - function block, 61
- VsPumpCtrl
 - function block, 65