

Preface

Thank you for purchasing Digital's GP77R Series Multi Unit E, hereafter referred to as the "Multi Unit E" (Model: GP077-MLTE41).

This Multi Unit E is attached to the rear face of the Graphic Operator Interface <Pro-face> of a large type GP77R Series unit (hereafter referred to as "the GP") and enables data input/output to a CF Card, as well as sound production.

This manual describes how to use the Multi Unit E correctly and safely, while it is installed in a GP. Also, for information on the correct and safe use of the GP, please refer to the GP-477R/577R Series User Manual's "Chapter 1-1 Prior to Operating the GP" (sold separately).

<Note>

- 1) It is forbidden to copy the contents of this manual, in whole or in part, except for the user's personal use, without the express permission of the Digital Electronics Corporation of Japan.
- 2) The information provided in this manual is subject to change without notice.
- 3) This manual has been written with care and attention to detail; however, should you find any errors or omissions, please contact the Digital Electronics Corporation and inform us of your findings.
- 4) Please be aware that Digital Electronics Corporation shall not be held liable by the user for any damages, losses, or third party claims arising from the uses of this product.
- 5) This unit is UL/c-UL(CSA) approved and CE marked. However, installing this unit in a GP unit that is not UL/c-UL(CSA) approved and CE marked will cause the this unit to lose its UL/c-UL(CSA) approval and CE marking.

All Company/Manufacturer names used in this manual are the registered trademarks of those companies.

© Copyright 1999, Digital Electronics Corporation

Table of Contents

Preface	i
Table of Contents	ii
Essential Safety Precautions	iv
General Safety Precautions	v
UL/c-UL(CSA) Application Notes	vi
CE Marking Notes	vi
Package Contents	vii
Multi Unit E Model Name	vii
Separately Sold Options	vii
Compatible Units and Software	viii
Documentation Conventions	viii

CHAPTER 1 MULTI UNIT E OVERVIEW

1.1 Multi Unit E Features	1-1
1.2 System Configuration	1-2
1.3 Network Configuration	1-3
1.3.1 Screen Creation Software (GP-PRO/PBIII) Settings	1-3

CHAPTER 2 SPECIFICATIONS

2.1 Multi Unit E Specifications	2-1
2.1.1 General	2-1
2.1.2 Structural	2-1
2.1.3 Functional	2-2
2.2 Part Names and Functions	2-3

CHAPTER 3 INSTALLATION AND CONNECTION

3.1 Multi Unit E Installation	3-1
3.2 CF Card Insertion/Removal	3-3
3.2.1 Inserting the CF Card	3-4
3.2.2 Removing the CF Card	3-4
3.3 Attaching the Speaker	3-5

Preface

CHAPTER 4 CF CARD

4.1	CF Card Handling	4-1
4.2	CF Card Initialization	4-3
4.3	Screen Data Backup	4-5

CHAPTER 5 MAINTENANCE

5.1	Troubleshooting.....	5-1
5.1.1	Ethernet Troubleshooting	5-2
5.2	Self-Diagnosis	5-4

INDEX

Essential Safety Precautions

This manual includes procedures that must be followed to operate the Multi Unit E and the GP correctly and safely. Be sure to read this manual and any related materials thoroughly to understand the correct operation and functions of the Multi Unit E and the GP.

Meaning of Safety Icons

To allow you to use the Multi Unit E and the GP correctly, throughout this manual the following icons are provided next to operations requiring special attention. The operations described with these icons contain essential safety information. These icons are used to describe the following situations:



Where severe injury, death or major equipment damage can occur.



Where bodily injury or machine damage can occur.

WARNINGS

When using the Multi Unit E and the GP:

- Due to the possibility of an electric shock occurring during the installation and wiring of the Multi Unit E, be sure that the GP's power cord is unplugged from the main power prior to starting either of these procedures.
- Due to the possibility of fire or electric shock, do not disassemble or modify the Multi Unit E.

CAUTIONS

When using the Multi Unit E and the GP:

- Be sure not to touch the inner face of the Multi Unit E's circuit board.
- When inserting or removing the CF Card, be sure to turn the Multi Unit E's access switch OFF, and be sure the access lamp is not lit. This will prevent damage to the CF Card's internal data.



CAUTIONS

- **While accessing the CF card, NEVER turn OFF or reset the GP, and attach or remove the CF Card. If you wish to perform these operations, create an application screen that prevents access to the CF Card.**

Reference GP-PRO/PB III for Windows Tag Reference Manual (contained in the screen editor software package)

- **Please only use CF Cards manufactured by the Digital Electronics Corporation. If another manufacturer's CF card is used, the Multi Unit E's specification conditions will not be satisfied.**
- **Data accidentally deleted from the CF Card cannot be recovered. Due to the danger of unforeseen accidents, be sure to back up all screen and CF Card data regularly.**

General Safety Precautions

To Prevent the Multi Unit E From Being Damaged:

- DO NOT allow water, liquids, or metal particles to enter the Multi Unit E, since any of them may cause the unit to malfunction or give the user an electric shock.
- DO NOT store the unit in the following locations:
 - Where the unit will be exposed to direct sunlight.
 - Where temperature or dust levels are excessively high.
 - Where excessive vibration can occur.
- The Multi Unit E is a high precision piece of equipment. DO NOT subject it to excessive shocks.
- DO NOT store the unit in locations where chemicals and chemical vapors can attach to or enter the unit.
- DO NOT use thinner or organic solutions to clean the Multi Unit E. When the unit's external cover becomes dirty, soak a soft rag into diluted neutral detergent, wring it well and gently wipe the unit's cover. NEVER attempt to clean the Multi Unit E's internal circuit board.

UL/c-UL(CSA) Application Notes

The GP077-MLTE41 is a UL/c-UL(CSA) listed product. (UL file No.E182139)

This unit conforms as a product to the following standards:

UL1604 and UL508

Electrical Equipment for use in Class I and II, Division 2 and Class III Hazardous (Classified) Locations.

CAN/CSA-Nos. 142, and 213-M1987

Standard for Safety of Information Technology Equipment, including Electrical Business Equipment

GP077-MLTE41 (UL Registration Model: 2880015-01)

- Be sure that this unit is mounted at least 100 mm away from any adjacent structures or equipment. If these requirements are not met, the heat generated by the unit's internal components may cause the unit to fail to meet UL/c-UL(CSA) standard requirements.

UL1604 Compliance Conditions and Handling Cautions:

1. Power, input and output (I/O) wiring must be in accordance with Class I, Division 2 wiring methods - Article 501- 4(b) of the National Electrical Code, NFPA 70 within the United States, and in accordance with Section 18-152 of the Canadian Electrical Code for units installed within Canada and in accordance with the authority having jurisdiction.
2. Suitable for use in Class I, Division 2, Groups A, B, C and D hazardous or non-hazardous locations only.
3. WARNING: Explosion hazard - substitution of components may impair suitability for Class I, Division 2.
4. WARNING: Explosion hazard - when in hazardous locations, turn power OFF before replacing or wiring modules.
5. WARNING: Explosion hazard - do not disconnect equipment unless power has been switched OFF, or the area is known to be non-hazardous.

CE Marking Notes

The GP077-MLTE41 is a CE marked product that conforms to EMC directives EN55011 class A and EN50082-2.

For detailed CE marking information, contact the Digital Electronics Corporation.

Package Contents

The Multi Unit E's packing box contains the items listed below. Please check to confirm that all items shown below have been included.

■ **Multi Unit E**
(GP077-MLTE41)

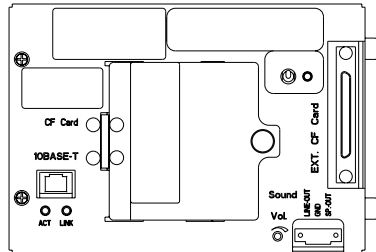

■ **GP77R Series**
Multi Unit
User Manual (1)

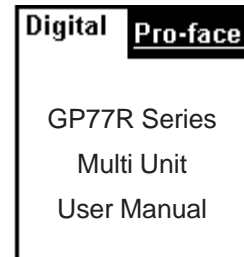

This unit has been carefully packed, with special attention to quality. However, should you find anything damaged or missing, please contact your local GP distributor immediately for prompt service.

Multi Unit E Model Name

The "Multi Unit E" is referred to by the following model number.

	Model Name	Model Type	Standard	I/F
Multi Unit	Multi Unit E	GP077-MLTE41	UL/c-UL (CSA) Approved & CE-Marked	10BASE-T

Separately Sold Options

The following optional items are available for the Multi Unit E.

- **CF Card (8MB)** **GP077-CF10**
- **CF Card (16MB)** **GP077-CF20**
- **CF Card adapter** **GP077-CFAD10**
- **CF Card front maintenance unit** **GP077-CFFM10**
- **Pin Jack Cable** **GP077-SDAD10**

Compatible Units and Software

The following hardware and software are compatible with the Multi Unit E

■ GP Units



GP-477R Series, GP-577R Series Units

■ GP Software

- GP-PRO/PBIII for Windows version 4.0 or later,
- Pro-Server with Pro-Studio for Windows version 2.0 or later.

Documentation Conventions

The list below describes the documentation conventions used in this manual.

Symbol	Meaning
	Indicates important information or procedures that <u>must</u> be followed for correct and risk-free software/device operation.
*1	Refers to useful or important supplemental information.
1) , 2)	Indicates steps in a procedure. Be sure to perform these steps in the order given.
	Refers to useful or important supplemental information.
	Indicates useful or important supplemental information.
GP Screen Editor Software	Indicates the GP-PRO/PBIII for Windows screen editor software, version 4.0 or later.
Multi Unit	Indicates GP77R Series Multi Unit.
GP	Indicates GP77R series large type units.

Chapter

1 Multi Unit E Overview

1. Multi Unit E Features
2. System Configuration
3. Network Configuration

1.1 Multi Unit E Features

Attaching the Multi Unit E allows you to read and write data to and from a CF card, as well as produce sound output from the GP.

Reference *For detailed information about CF Card usage, refer to the **GP-PRO/PBIII for Windows Operation Manual** (included with software)*

The Multi Unit E is also equipped with an Ethernet 10BASE-T interface, which allows you to connect the GP directly with a PLC or a Personal Computer (PC). In addition, the "2-Way" driver feature allows you to transmit and receive data between a host personal computer and a PLC connected to a GP, via an Ethernet network.

Reference *For detailed information about the 2-Way Driver feature, refer to the **Pro-Server with Pro-Studio for Windows Operation Manual** (included with Pro-Server with Pro-Studio for Windows software)*



- To use the Multi Unit E, GP-PRO/PB III for Windows Version 4.0 or later is required.
- To use the 2-Way driver, Pro-Server with Pro-Studio for Windows Version 2.0 or higher is required.

1.2 System Configuration

The following is an example of a system configuration when using the Multi Unit E.

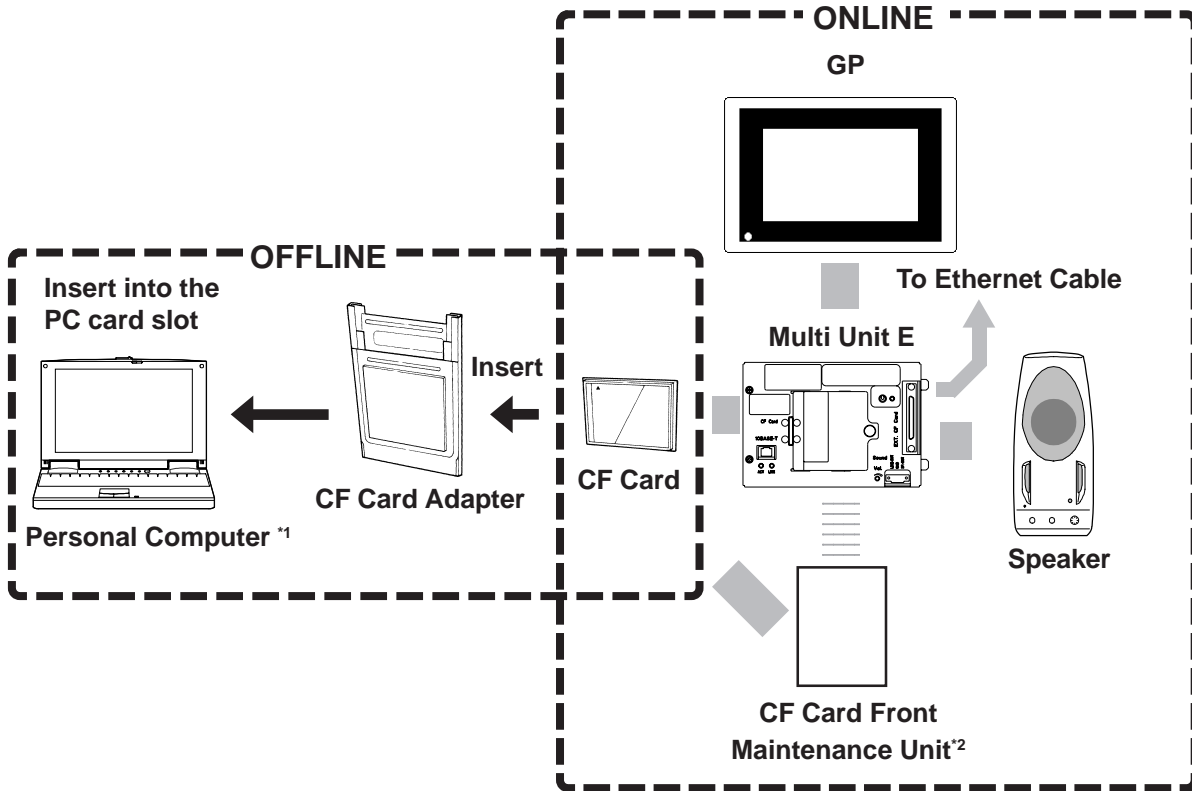

**1 A personal computer running Windows 95/98/NT 4.0 can operate is recommended.*

**2 When the CF Card Front Maintenance Unit is attached, the Multi Unit E's CF Card Interface cannot be used.*

1.3 Network Configuration

The Ethernet network should be created using 10BASE-T. The following is an example connection layout:

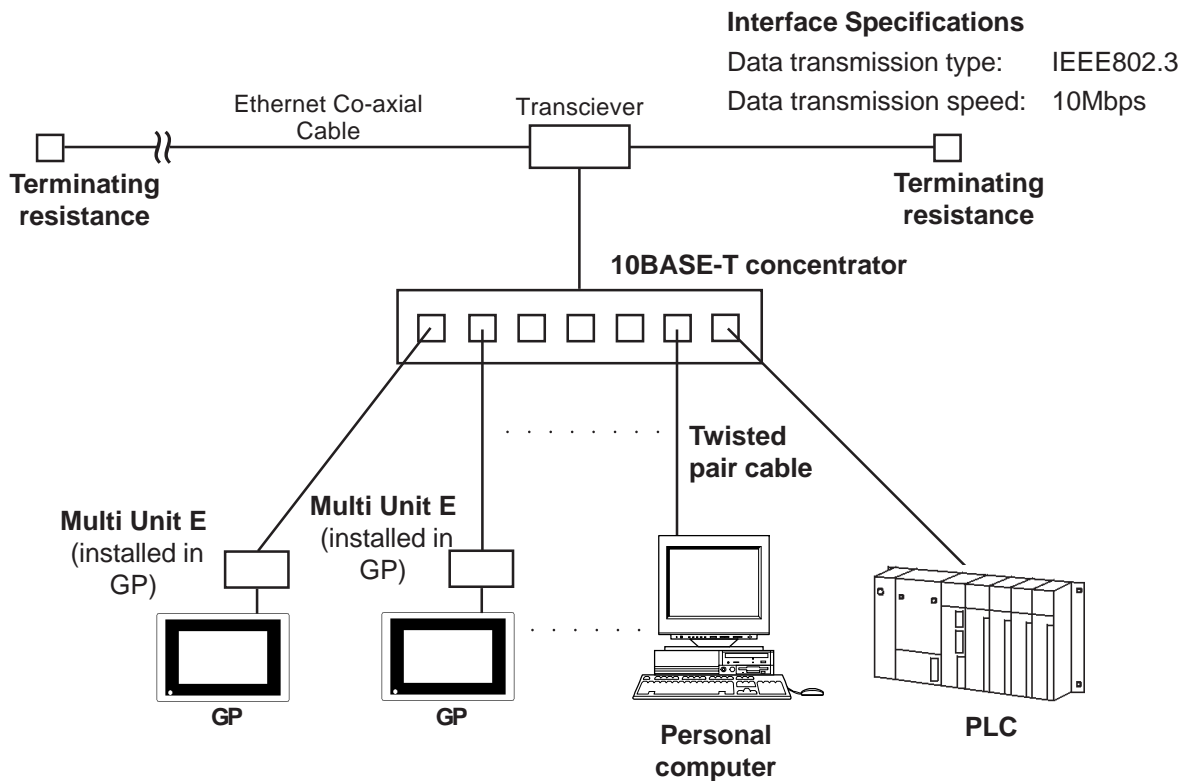

1.3.1 Screen Creation Software (GP-PRO/PBIII) Settings

When the Multi Unit E is being used to perform Ethernet network data communication, be sure to choose either the [Ethernet Compatible PLC], or [MultiLink Ethernet Type] for the screen creation software's [PLC Type] setting.

Also, when using the 2-Way Driver feature, after setting the [PLC type], be sure to also select the 2-Way Driver's [2-Way Ether] feature.

In both cases, be sure to also enter all necessary network information, such as IP addresses, etc.

For detailed information about these features refer to:

Reference *GP-PRO/PBIII for Windows Operation Manual, PLC Connection Manual (included with screen creation software), Pro-Server with Pro-Studio for Windows Operation Manual (included with software)*

Memo

Chapter

2 Specifications

1. Multi Unit E Specifications
2. Part Names and Functions

2.1 Multi Unit E Specifications

2.1.1 General

Rated Voltage	DC5V+/-5% (Supplied from GP)
Power Consumption	3.0W or less (When CF card I/F is in use)
Ambient Operating Temperature	0° to 50°C (cannot exceed temperature limits of GP)
Ambient Humidity	20%RH to 85%RH (cannot exceed humidity limits of GP)
Ambient Storage Temperature	-10°C to 60°C
Vibration Resistance	10Hz to 25Hz (19.6m/s ² in X, Y and Z directions for 30 min. each)
Atmosphere	Free of corrosive gasses
Grounding (GP-477R/577R Unit)	100Ω or your country's applicable standard

2.1.2 Structural

Installation Method	Installed in expansion slot of GP77R Series large type unit
External Dimensions (mm)	167mm (W) x 117mm (H) x 40mm (D) (main unit only, including projections from terminal block)
Weight	Approx. 400g
Cooling Method	Natural air circulation

2.1.3 Functional

CF Card I/F	CF Card slots: 1 Access Lamp Access Enable/Disable Switch
Sound I/F	External Speaker Connection (via connectors) Monaural 1CH Speaker Out: 70mW (Rated Load:8Ω, Frequency: 1kHz) Line-Out: 2.7Vp-p (Rated Load:10kΩ) Terminal Block: MC 1,5/3-STF-3,81 (Phoenix Contact Co.) Wire Rating: AWG#28 to 16
Expansion CF Card I/F	Front Maintenance CF Card Unit Connector
External Communication I/F (10BASE-T)	Connector: RJ-45 (8 pin modular jack) I/O Spec.: IEEE802.3 compliant Transfer Speed: 10Mbps Recommended Cable: IEE802.3 compliant

2.2 Part Names and Functions

(Unit: mm)

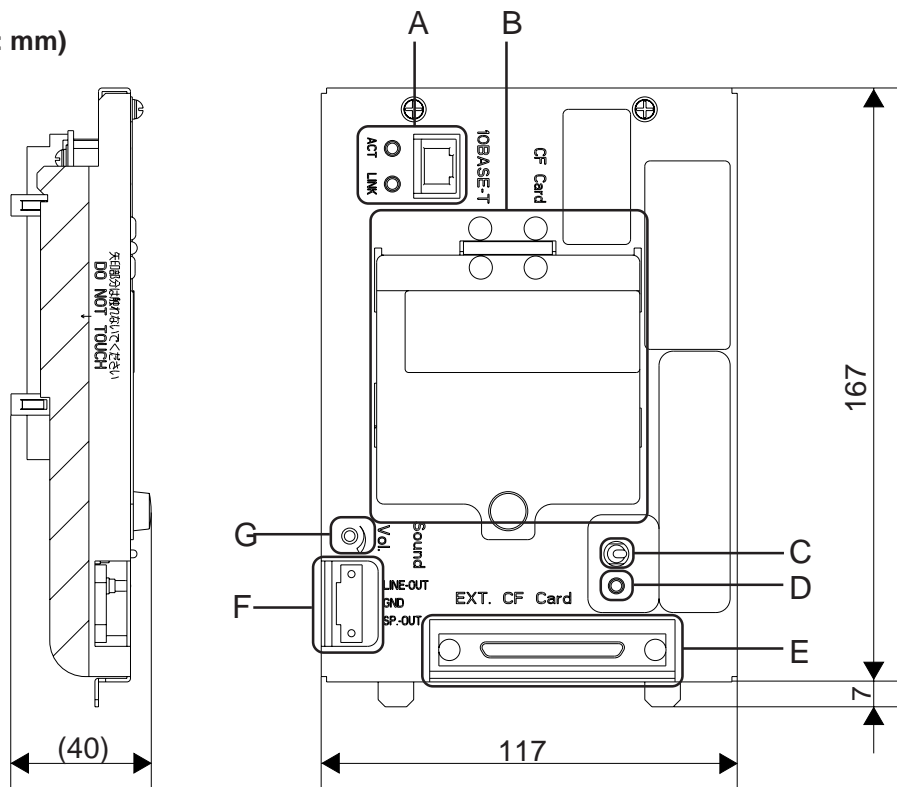

A: 10BASE-T

LED lamps have the following meaning:

ACT (Orange)	Lights when power is ON. Blinks when receiving data.
LINK (Green)	Blinks when LINK is used.

B: CF Card ^{*1}

Provides CF Card Interface.
Used for inserting and removing a CF Card.

C: CF Card Access Switch

When this switch is turned ON, access to the CF card is enabled.

D: CF Card Access LED

When the CF card access switch is turned ON, this LED lights. Although, when the CF card access switch is turned OFF, this LED goes out, it is always lit while the access to the CF card is being performed.

E: EXT. CF Card

CF Card Front Maintenance Unit
Interface Connector

F: Sound

Line Out	Line Output
GND	GND
SP-OUT	Speaker Output

G: Vol

Controls the sound output volume.

**1 When the CF Card Front Maintenance Unit is connected, the Multi Unit E's CF Card interface cannot be used.*

Memo

Chapter

3 Installation and Connection

1. Multi Unit E Installation
2. CF Card Insertion/Removal
3. Attaching the Speaker

3.1 Multi Unit E Installation



WARNING

Due to the possibility of an electric shock occurring during the installation and wiring of the Multi Unit E, be sure that the GP's power cord is unplugged from the main power prior to starting either of these procedures.



CAUTIONS

- Be sure not to touch the inner face of the Multi Unit E's circuit board.
- When installing the Multi Unit E in the GP, be sure to wear gloves.

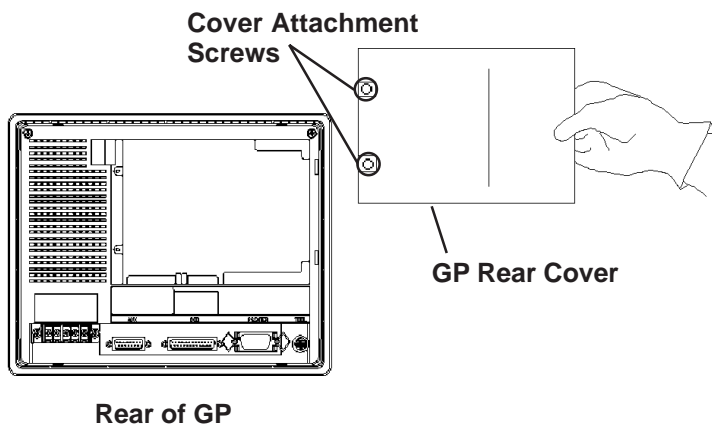

1. Unplug the GP's power cord
2. Unscrew the two cover attachment screws on the rear cover of the GP, and remove the Rear Cover.

*These drawings use the GP- 477R series unit

Chapter 3 - Installation and Connections

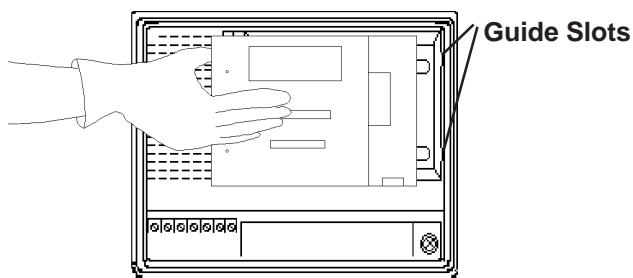
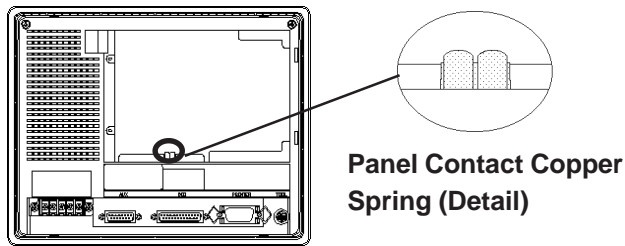
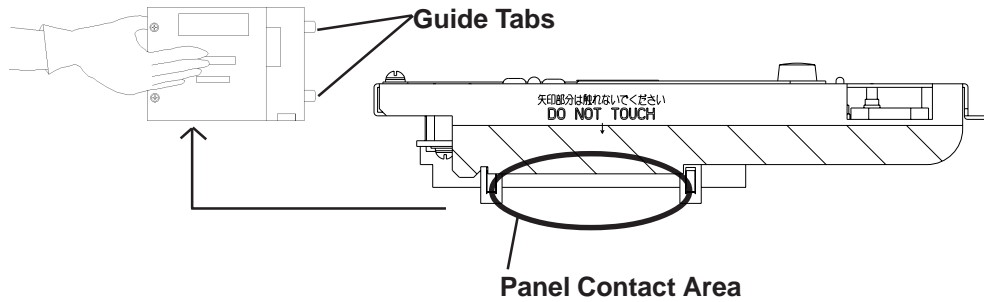

3. Insert the protruding tabs of the Multi Unit E into the Guide Slots.

Be sure to install the unit so that the smooth metal surface of the Multi Unit E faces outward.

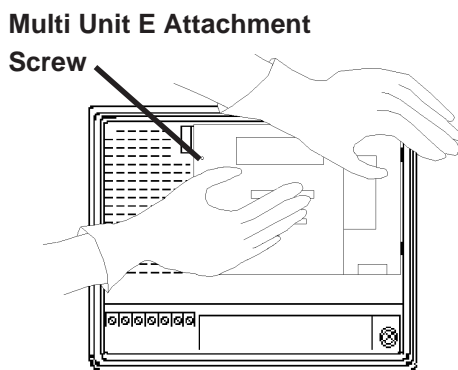

4. Hold the GP with your left hand and insert the Multi Unit E into its slot with your right hand.

Be sure that the unit is seated correctly in place, so that no gaps remain between the GP and the Multi Unit E.

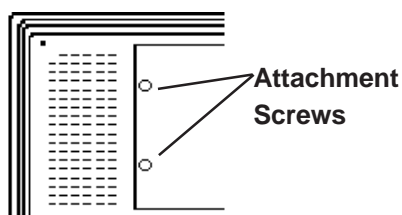

5. Reattach the attachment screws and secure the Multi Unit E to the GP.

3.2 CF Card Insertion/Removal



CAUTIONS

When using the Multi Unit E and CF Card, be sure to observe the following cautions:

- Prior to attachment or removal of the CF Card, be sure to turn the Multi Unit E's CF Card access switch OFF and confirm that the LED is not lit. Otherwise, the CF Card's internal data may be destroyed.
- While accessing the CF Card, NEVER turn OFF or reset the GP, and attach or remove the CF Card. If you wish to perform these operations, create an application screen that access to the CF Card is not available.

▼Reference▲ *GP-PRO/PB III for Windows Tag Reference Manual (included with screen editor software)*

- When attaching the CF Card, be sure to confirm the CF Card's front and back sides as well as CF Card connector position. If the CF Card is attached with its orientation incorrect, the CF Card, its internal data, and Multi Unit E may be destroyed.
- Be sure to use a CF Card made by the Digital Electronics Corporation. If another manufacturer's CF Card is used, the Multi Unit E's specifications will not be satisfied and performance cannot be guaranteed.
- Be sure to make backup data of the CF Card's internal data.

3.2.1 Inserting the CF Card

- 1) Turn the Multi Unit E's Access Switch OFF and confirm that the LED is not lit.
- 2) Unscrew the cover's stopper and open the cover (I, II)
- 3) Insert the CF Card. (III)
- 4) Push the card in until the ejector button is pushed out. (IV)
- 5) Close the cover and screw in the cover's stopper. (V, VI)
- 6) Turn the Multi Unit E's Access Switch ON.

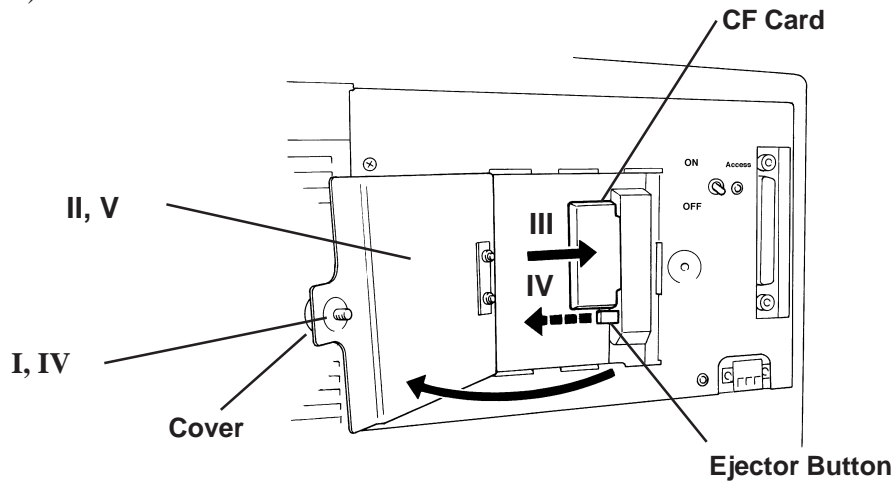

3.2.2 Removing the CF Card

- 1) Turn the Multi Unit E's Access Switch OFF and confirm that the LED is not lit.
- 2) Unscrew the cover's stopper and open the cover (I, II)
- 3) Push the ejector button. (III)
- 4) Pull the CF Card out directly from the Multi Unit E. (IV)
- 5) Close the cover and screw in the cover's stopper. (V, VI)

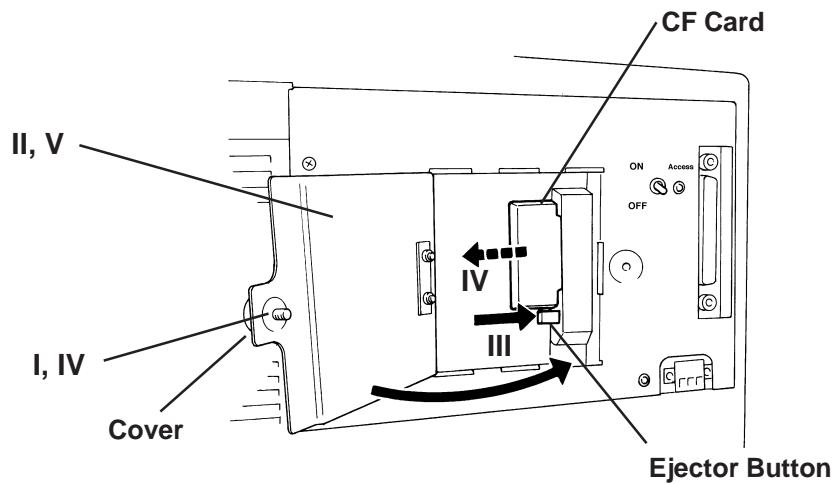

3.3 Attaching the Speaker

The following maker's speaker is used in the following example usage.

Maker Name	Model	Connector Name
Arrow Electrical Industries	NS-38	SP-OUT,GND
	NS-105	

In order to produce sound from the Multi Unit E, commercially available external speakers must be attached.

The following explanation connects a speaker by attaching Digital's Pin-Jack wires (GP077-SDAD10) to the Multi Unit E SP-OUT connector. When connecting to the LINE-OUT connector, a separate amplifier will be required.

■ Attaching the Speakers

- 1) Confirm that the GP's power cord is not connected to the power supply and the GP's power lamp is not lit.
- 2) Remove the Speaker Connector's two (2) attachment screws. (I)
- 3) Remove the Speaker Connector from the Multi Unit E's connector. (II)
- 4) Loosen the Speaker Connector's two (2) Wire Set screws. (III)
- 5) Insert both Pin-Jack wires completely into the connector. (IV)
(Brown wire is inserted in the SP-OUT hole, the black wire is inserted into the GND hole)
- 6) Tighten both Wire Set screws. (V)
- 7) Replace the Speaker Connector in the Multi Unit E's connector.
- 8) Reattach the Speaker Connector's two (2) attachment screws.(VI)
- 9) Connect the pin jack wires to the speaker's pin jack.

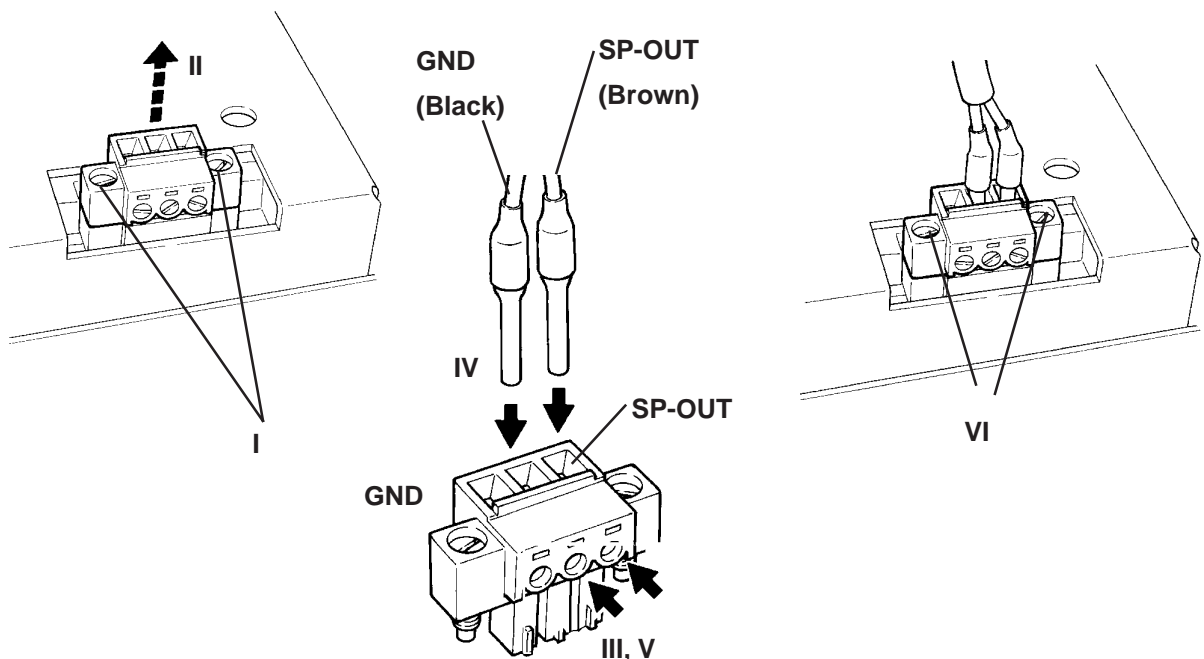

Memo

Chapter

4 CF Card

1. CF Card Handling
2. CF Card Initialization
3. Screen Data Backup

This chapter describes the precautions required when handling the CF Card, as well as the CF Card functions available when using the GP.

4.1 CF Card Handling



CAUTIONS

- **Be sure to use only CF Cards manufactured by the Digital Electronics Corporation. Multi Unit E performance cannot be guaranteed when using another manufacturer's CF Card.**
- **Be sure to follow the instructions given below to prevent the CF Card's internal data from being destroyed or a CF Card malfunction from occurring:**
 - **DO NOT bend the CF Card.**
 - **DO NOT drop or strike the CF Card against another object.**
 - **Keep the CF Card dry.**
 - **DO NOT touch the CF Card or Multi Unit E connectors.**
 - **DO NOT disassemble or modify the CF Card.**

The CF Card has a data overwrite limit of approximately 100,000 times. Therefore, be sure to back up all CF Card data regularly to another storage media. (100,000 times assumes the overwriting of 500KB of data in DOS format)

To view a CF Card's data on a personal computer, first, insert the CF Card into a CF Card Adapter. Then, insert the adapter into your personal computer's PC card slot. Depending on your model personal computer, the CF Card's data may not be able to be read correctly. Please contact your local GP distributor for a list of the latest CF Card and personal computer operation test results.

If your personal computer is not equipped with a PC card slot, please use a standard type PC Card or CF Card reader. All of Digital's CF Card operation testing has been performed using the following equipment.

Manufacturer Name	Model	Connection Type
I-O DATA DEVICE, INC.	CardDock-CF/P	Parallel port

The connection between a personal computer and CF Card reader has been tested using an IBM compatible machine. This does not mean, however, that all IBM compatible machine can be used. Please contact your PC or CF Card reader manufacturer directly for details.

4.2 CF Card Initialization

Here, the CF Card's initialization method is described. To perform initialization, however, the GP needs to have its system data downloaded from your PC via the screen editor software.

Be sure to use the following steps when initializing the CF Card.

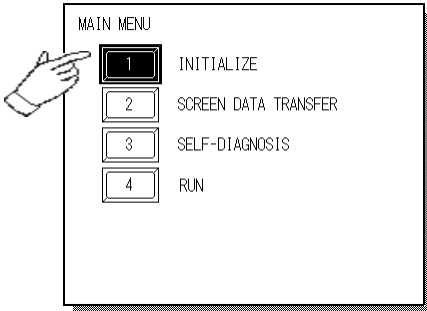
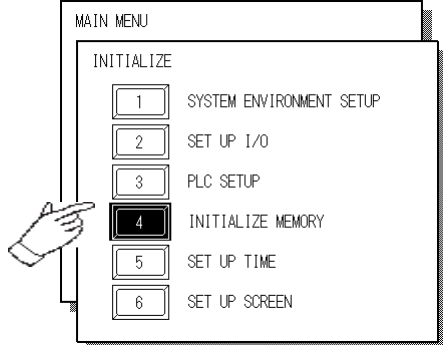
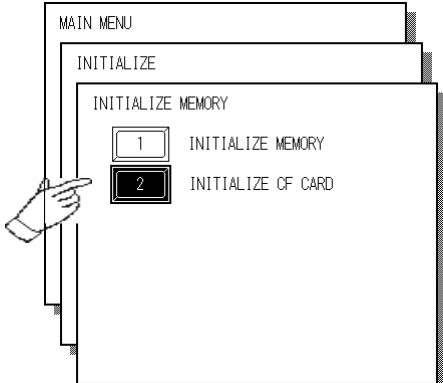
PROCEDURE	REMARKS
<p>① Select [INITIALIZE] from the GP OFFLINE mode's MAIN MENU.</p>  <p>The screenshot shows a 'MAIN MENU' with four options: 1 INITIALIZE, 2 SCREEN DATA TRANSFER, 3 SELF-DIAGNOSIS, and 4 RUN. A hand icon points to the '1 INITIALIZE' option, which is highlighted with a dark background.</p>	<p>Prior to starting operation, attach the Multi Unit E to the GP and insert the CF Card into the Multi Unit E.</p> <p>Reference <i>For instructions on how to enter OFFLINE mode, refer to the GP-477R/577R Series User Manual (sold separately).</i></p>
<p>② Select [INITIALIZE MEM]</p>  <p>The screenshot shows an 'INITIALIZE' menu with six options: 1 SYSTEM ENVIRONMENT SETUP, 2 SET UP I/O, 3 PLC SETUP, 4 INITIALIZE MEMORY, 5 SET UP TIME, and 6 SET UP SCREEN. A hand icon points to the '4 INITIALIZE MEMORY' option, which is highlighted with a dark background.</p>	
<p>③ Select [INITIALIZE CF-CARD].</p>  <p>The screenshot shows an 'INITIALIZE MEMORY' menu with two options: 1 INITIALIZE MEMORY and 2 INITIALIZE CF CARD. A hand icon points to the '2 INITIALIZE CF CARD' option, which is highlighted with a dark background.</p>	<p>If the Multi Unit E is not attached to the GP, this menu will not be displayed.</p>

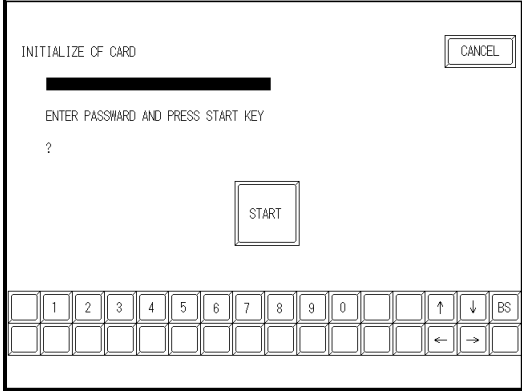
PROCEDURE	REMARKS
<p>④ Enter the password using the numeric keys provided on the screen.</p>  <p>⑤ Press the <input type="button" value="START"/> button, and the CF Card's initialization will start.</p> <p>⑥ When initialization is completed, the GP's display will return to the screen shown in step 3.</p>	<p>Enter the password registered in the screen editor software's [GP System Settings] screen, or in the GP's OFFLINE mode. If a password has not been registered yet, enter "1101".</p> <p>Reference Refer to <i>GP-PRO/PB III for Windows Operation Manual</i> (included in the screen editor software package) or each <i>GP's User Manual</i> (sold separately from the GP).</p>



Note: CF Card initialization erases all the data stored in the CF Card.

When the CF Card is initialized via the Mult Unit, a folder is created automatically. Data transferred to the CF Card is then stored in the following files.

Folder	Data Type	File Name
\file	Filing Data	ZF*****.BIN
\log	Logging data	ZL*****.CSV
\data	Image screen data	ZI*****.BIN
	Sound data	ZO*****.BIN
\mrm	GP backup data (MRM file)	ZC00001.MRM (fixed)
\trend	Trend graph data	ZT*****.CSV
	Sampling data	ZS*****.CSV
\alarm	Alarm data	
	- Active or Block 1 data	ZA*****.CSV
	- History or Block 2 data	ZH*****.CSV
	- Log or Block 3 data	ZG*****.CSV



- CF Card data file names must be 8 characters or less. These file names, however, are not compatible with the FAT32 file naming system.
- When storing new data in a CF Card that will require the overwriting of old data, the CF Card's available capacity (free space) must be larger than the size of data to be stored, since the new data is written before the old data is deleted.

4.3 Screen Data Backup

Screen data backup can be performed using a CF Card backup file (*.MRM). This backup data can also be copied to another GP unit and used there.

This section explains how to back up data to the CF Card and how to copy screen data to a GP that has been previously setup, i.e. has had all its required system data sent to it via the screen editor software.

Only one (1) data file can be backed up to the CF Card at a time.

■ Backing Up a File to a CF Card (GP internal memory → CF Card)

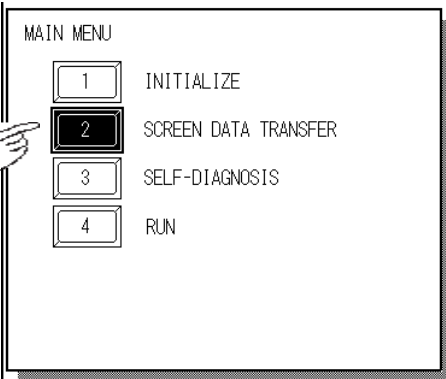
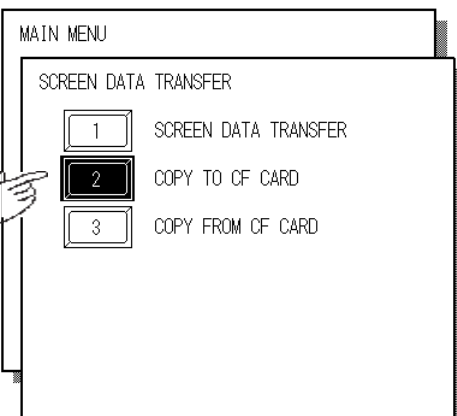
PROCEDURE	REMARKS
<p>① Select [TRANSFER SCREEN DATA] in the GP OFFLINE mode's MAIN MENU.</p>	<p>Before performing this procedure, be sure to attach the Multi Unit E to the GP and insert the CF Card into the Multi Unit E.</p> <p>Reference To enter the GP OFFLINE mode, refer to GP-477R/577R Series User Manual (sold separately).</p>
	
<p>② Select [COPY TO CF-CARD]</p>	<p>If the Multi Unit E has not been attached to the GP, this menu will not appear.</p>
	<p>If a backup file (*.MRM) already exists in the CF Card, that data will be overwritten by your new data.</p>

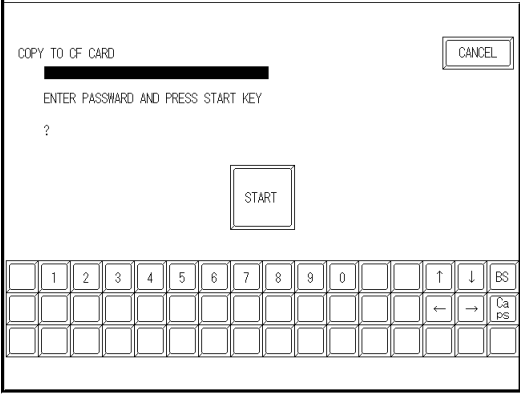
PROCEDURE	REMARKS
<p>③ Use the screen's numeric keys to enter the password.</p>	<p>Be sure to enter the password registered in the screen editor software's [Screen Transfer] area. If a password has not been registered yet, enter "1101".</p>
	<p>Reference Refer to <i>GP-PRO/PB III for Windows Operation Manual</i> (included in the screen editor software package)</p>
<p>④ Press the <input type="button" value="START"/> button to start copying data to the CF Card.</p>	<p>While data is being copied to the CF Card, DO NOT turn OFF or reset the GP.</p>
<p>⑤ When copying is completed, the GP's display will return to the screen shown in step 2.</p>	

■ Copying a Backup File from the CF Card to the GP (CF Card → GP internal memory)

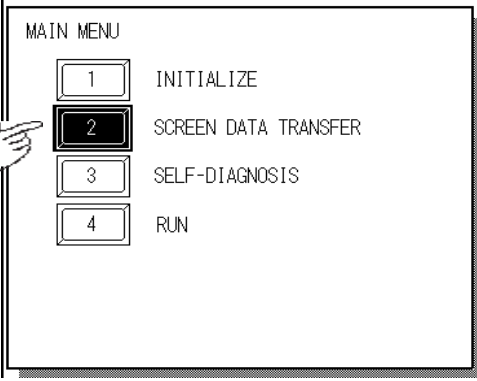
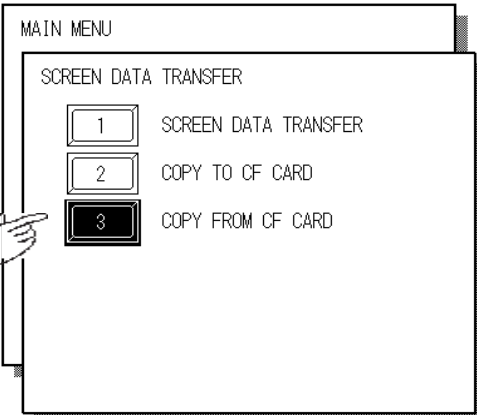
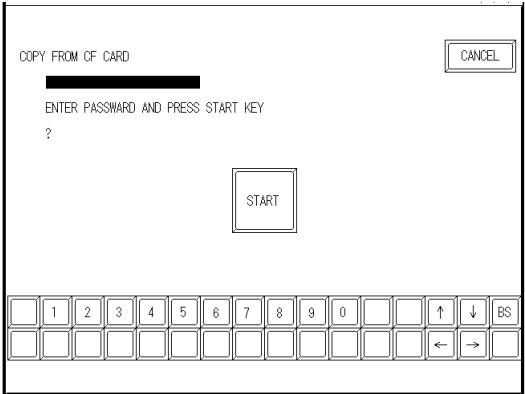
PROCEDURE	REMARKS
<p>① Select [TRANSFER SCREEN DATA] in the GP OFFLINE mode's MAIN MENU.</p>	<p>Prior to starting operation, install the Multi Unit E in the rear of the GP and insert a CF Card into the Multi Unit E.</p>
 <p>MAIN MENU</p> <ul style="list-style-type: none"> 1 INITIALIZE 2 SCREEN DATA TRANSFER 3 SELF-DIAGNOSIS 4 RUN 	<p>Reference To enter the GP's OFFLINE mode, refer to <i>GP-477R/577R Series User Manual</i> (sold separately).</p>
<p>② Select [COPY FROM CF-CARD].</p>	<p>When the [COPY FROM CF-CARD] is performed, data stored in the backup SRAM will be erased.</p> <p>If the protocol downloaded to the destination GP is different from the protocol for the file to be copied, an error message "Applicable PLC has not been set up" will appear. Be sure to only copy a backup file with the same protocol as the GP.</p>
 <p>MAIN MENU</p> <p>SCREEN DATA TRANSFER</p> <ul style="list-style-type: none"> 1 SCREEN DATA TRANSFER 2 COPY TO CF CARD 3 COPY FROM CF CARD 	<p>Enter the password registered in the screen editor software's [GP System Settings] screen, or in the GP's OFFLINE mode. If a password has not been registered yet, enter "1101".</p>
<p>③ Enter the password using the GP screen's numeric keys.</p>	<p>Reference Refer to <i>GP-PRO/PB III for Windows Operation Manual</i> (contained in the screen editor software package) or <i>GP-477R/577R Series User Manual</i> (sold separately).</p>
 <p>COPY FROM CF CARD</p> <p>ENTER PASSWORD AND PRESS START KEY</p> <p>?</p> <p>START</p> <p>1 2 3 4 5 6 7 8 9 0 ↑ ↓ BS</p> <p>← →</p>	<p>While data is being copied to the CF Card, DO NOT turn OFF or reset the GP.</p>
<p>④ Press the START button to start the copying of the data to the CF Card.</p>	

Memo

Chapter

5 Maintenance

1. Troubleshooting
2. Self-Diagnosis

This chapter describes the Multi Unit E's maintenance procedures.

5.1 Troubleshooting

Here, problems related to the Multi Unit E are explained.

Reference For the Ethernet-related troubleshooting, refer to **5.1.1 Ethernet Troubleshooting**.



WARNING

Prior to attaching or wiring the Multi Unit E, confirm that both the GP and the Multi Unit E power cords are disconnected from the main power supply. Otherwise, an electric shock may occur.

■ Multi Unit E Problems and Countermeasures

Problem	Countermeasures
Cannot access the CF Card	Check if the Multi Unit has been installed in the GP correctly.
	Check if the CF Card has been inserted into the Multi Unit correctly.
	Check if the CF Card ACCESS switch has been turned ON.
No Sound Output	Check if the Multi Unit has been installed in the GP correctly.
	Check if the speaker has been connected to the GP correctly.
	Check if the Multi Unit's volume (Vol) is turned up.

5.1.1 Ethernet Troubleshooting

If trouble occurs while data is being sent between the GP and the Host via the network, use the following flow chart to find the cause(s) of the problem.

Additionally, when an error message appears on the GP screen, be sure to make a note of the error code.

Reference *GP 477R/577R Series User Manual* (sold separately).

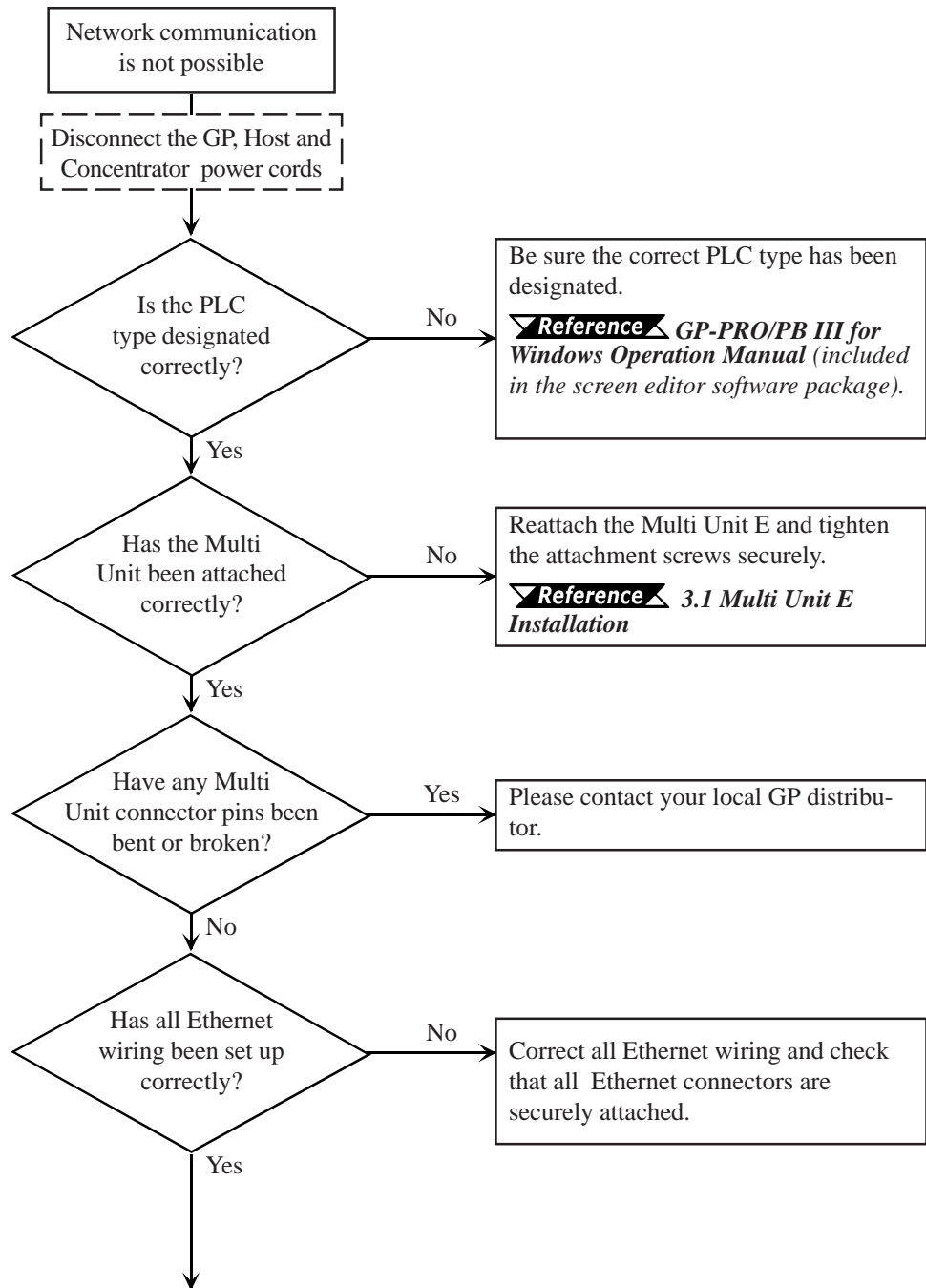

Chapter 5 - Maintenance

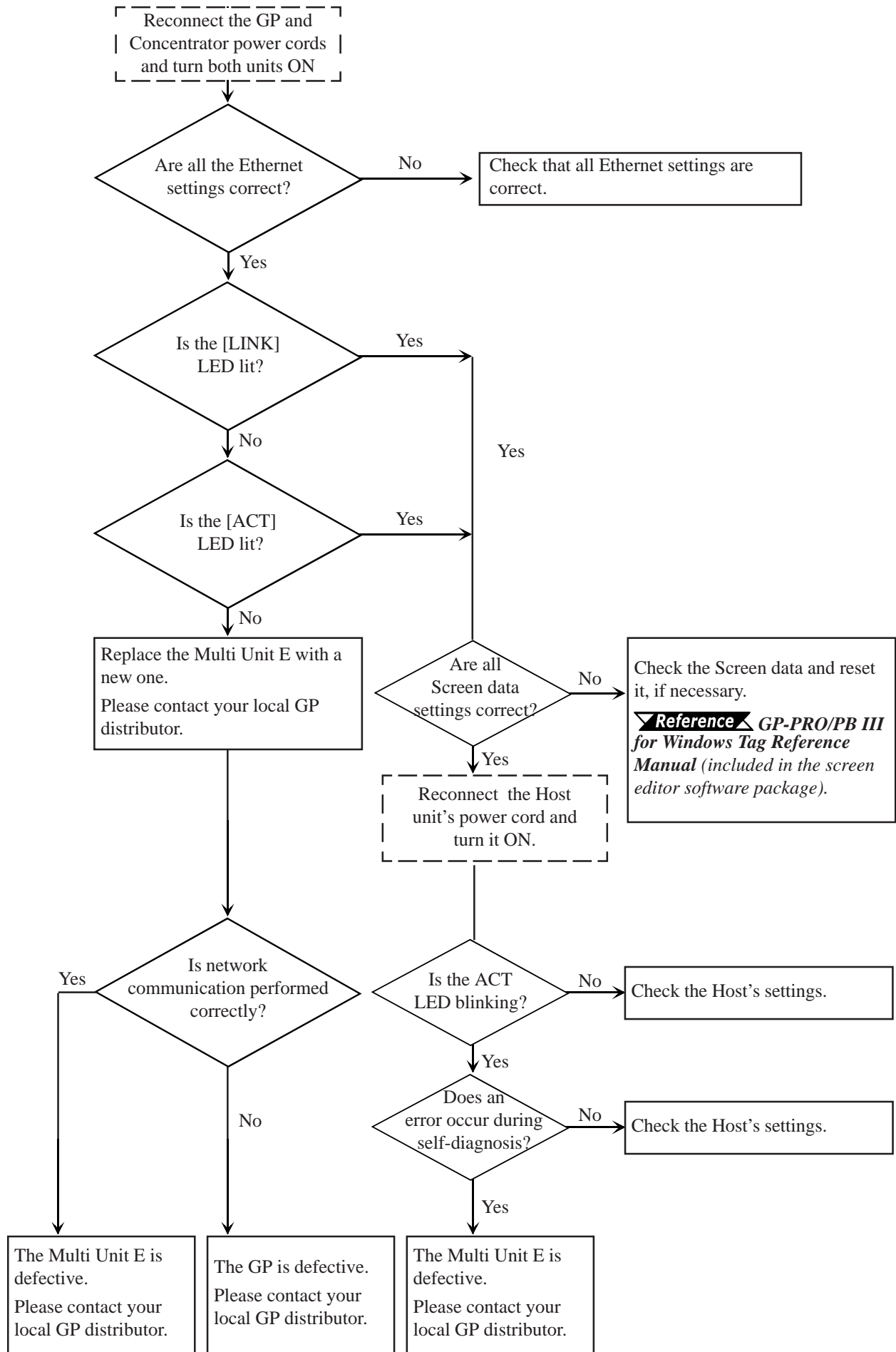

5.2 Self-Diagnosis

After the Multi Unit E is installed in the rear of the GP, the Multi Unit E self-diagnosis selection will be added to the GP OFFLINE mode's self-diagnosis menu. Here, self-diagnosis items related to the Multi Unit E are described.

*For the detailed information about the OFFLINE mode and the self-diagnosis feature, **Reference** GP 477R/577R Series User Manual (sold separately).*

The Multi Unit E's self-diagnosis features include the following items:

- CF Card Check (CF-CARD)
- CF Card Check Sum (CF-CARD CHECKSUM; inside CF-CARD)
- Sound Output Check (SOUND I/F)
- SIO Check (SIO CHECK)

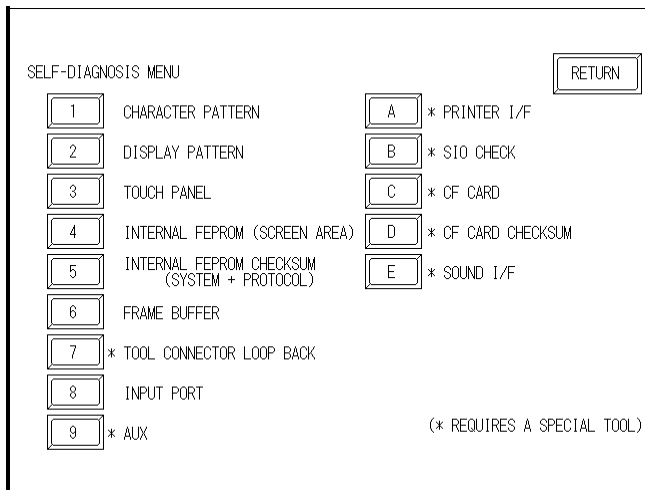

To display this screen, the GP needs to have system information sent to it via your PC's screen editor software. Items related to the Multi Unit E will be displayed only after the Multi Unit E is attached to the GP.

Chapter 5 - Maintenance

■ CF Card Check

This feature checks the data read/write to the CF card. To perform this check a CF card is required, with more than 1KB of free space.

- ① Press the “C” button in the [SELF-DIAGNOSIS MENU].
- ② After inserting the CF Card in the Multi Unit E, press the “START” button in the [CF CARD] menu.
- ③ If the CF card’s data read/write feature is normal, “OK” will display. If not, an error message will display.

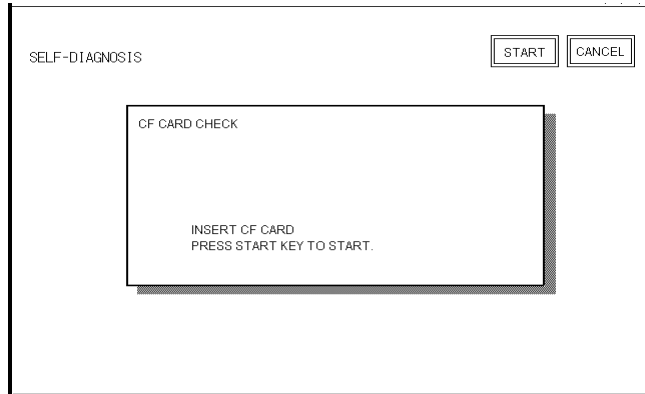

■ CF Card Check Sum

This uses the CF card file’s check sum feature to check the CF card. To perform this check, a CF card must be inserted into the Multi Unit E.

File types that can be checked are:

- Filing data
- CF card’s image screen data
- CF card’s sound data

- ① Press the “D” button in the [SELF-DIAGNOSIS MENU].
- ② After inserting the CF Card in the Multi Unit E, press the “START” button in the [CF CARD] menu.
- ③ After the check is completed, the number of checked files, number of error files, and the file name that last became an error will display.

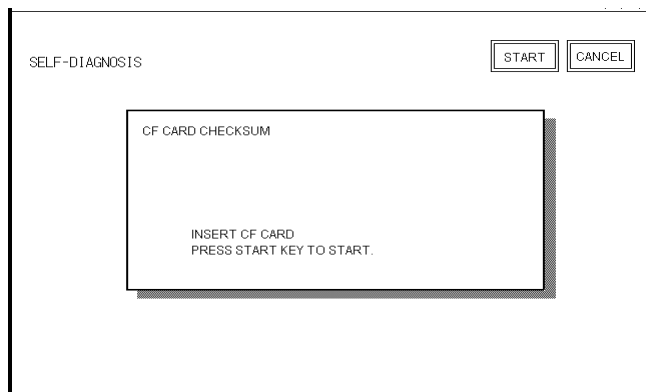

■ Sound Output Check

This checks the interface for producing sound. To perform this check, a speaker must be attached to the Multi Unit E.

- ① Press the “E” button in the [SELF-DIAGNOSIS MENU].
- ② Confirm that the speaker and Multi Unit E are all connected and press “START”.
- ③ If the tones for “Do”, “Re”, and “Mi” are played, the speaker is correctly connected.

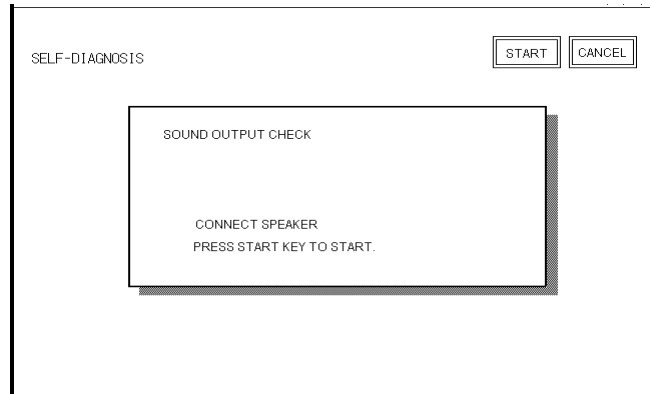

■ SIO Check

This feature checks if communication over the Ethernet network is being performed normally. To use this self-diagnosis feature, first connect a Concentrator and the Ethernet cable.

- ① Press the “B” button in the [SELF-DIAGNOSIS MENU].
- ② If all communication conditions are normal, both “OK” and the ethernet address will display. If not, an error message will display.

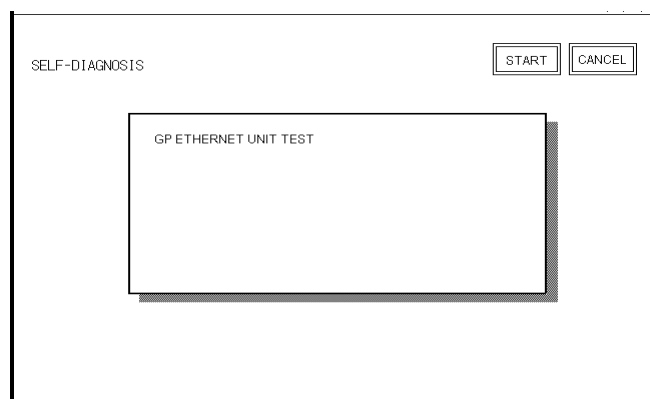

Index

Characters

10BASE-T	1-3, 2-3
10BASE-T concentrator	1-3
2-Way Driver	1-3
2-Way driver	1-1
2-Way Ether	1-3

A

Access switch	iv
amplifier	3-5
Attaching the Speaker	3-5
Attaching the Speakers	3-5
available capacity (free space)	4-4

B

Backing Up a File	4-5
backup data	3-3
Bodily injury	iv

C

CAUTIONS	3-1, 4-1
CE Marking Notes	vi
CF Card	v, 2-3, 4-4
CF Card Access LED	2-3
CF Card Access Switch	2-3
CF Card Adapter	1-2, 4-1
CF Card adapter	vii
CF Card Check	5-5
CF Card Check Sum	5-5
CF Card Front Maintenance Unit	1-2, 2-3
CF Card Front Maintenance Unit*2	1-2
CF Card Handling	4-1
CF card image screen data	5-5
CF Card Initialization	4-3
CF Card initialization	4-4
CF Card Insertion/Removal	3-3
CF Card malfunction	4-1
CF Card reader	4-2
CF card sound data	5-5
Communication Check	5-6
communication conditions	5-6
Compatible Units and Software	viii
COPY FROM CF-CARD	4-7

Copying	4-7
Cover Attachment Screws	3-1

D

data copying	4-6
data file names	4-4
data overwrite limit	4-1
Data transmission type	1-3
defective	5-3
Documentation Conventions	viii
dust levels	v

E

Ejector Button	3-4
electric shock	iv, 3-1, 5-1
error code	5-2
error message	4-7, 5-5
Essential Safety Precautions	iv
Ethernet Cable	1-2
Ethernet cable	5-6
Ethernet Co-axial Cable	1-3
Ethernet Compatible PLC	1-3
Ethernet network	1-3
Ethernet Troubleshooting	5-2
Ethernet-related troubleshooting	5-1
EXT. CF Card	2-3

F

FAT32	4-4
Features and Performance	2-3
Filing data	5-5
Functional	2-2

G

General Safety Precautions	v
GP Rear Cover	3-1
GP Software	viii
GP-477R Series, GP-577R Series Units	viii
GP077-MLTE41	i
Guide Slots	3-2

- H**
- Host settings 5-3
- I**
- IBM compatible machine 4-2
 - IEEE802.3 1-3
 - INITIALIZE 4-3
 - Inserting the CF Card 3-4
 - Installation 3-1
 - Interface Specifications 1-3
 - internal circuit board v
 - internal data 3-3
 - IP addresses 1-3
- L**
- local GP distributor 4-1
- M**
- Multi Unit connector 4-1
 - Multi Unit E Features 1-1
 - Multi Unit E Installation 3-1
 - Multi Unit E Model Name vii
 - Multi Unit E performance 3-3, 4-1
 - Multi Unit E Specifications 2-1
 - Multi Unit Problems 5-1
 - MultiLink Ethernet 1-3
 - MultiLink Ethernet Type 1-3
- N**
- network communication 5-3
 - Network Configuration 1-3
 - numeric keys 4-7
- O**
- OFFLINE 1-2
 - OFFLINE mode 4-3
 - ONLINE 1-2
 - organic solutions v
 - overwrite limit 4-1
- P**
- Package Contents vii
 - Panel Contact Area 3-2
 - Part Names and Functions 2-3
 - password 4-6
 - personal computer 4-1
 - Pin Jack Cable vii
 - Pin-Jack 3-5
 - PLC Type 1-3
 - power cord iv, 5-1
 - precision equipment v
 - Printer Interface Check 5-6
 - Pro-Server with Pro-Studio for Windows 1-1
 - Problems and Countermeasures 5-1
- R**
- Registered trademarks i
 - Removing the CF Card 3-4
- S**
- Safety Icons iv
 - Safety Precautions iv, vii
 - Screen Creation Software (GP-PRO/PBIII) Settings 1-3
 - Screen Data Backup 4-5
 - Self-Diagnosis 5-4
 - Separately Sold Options vii
 - SIO Check 5-6
 - Sound 2-3
 - sound output 1-1
 - Sound Output Check 5-6
 - speaker 5-6
 - Speaker Connector 3-5
 - storage media 4-1
 - Structural 2-1
 - Structural Specifications 2-1
 - System Configuration 1-2
 - system data download 4-3
- T**
- Terminating resistance 1-3
 - Transceiver 1-3
 - Troubleshooting 5-1, 5-2
 - Twisted pair cable 1-3
- U**
- UL/c-UL(CSA) i
 - UL/c-UL(CSA) Application Notes vi
 - UL1604 and UL508 vi
 - Users Manual vii

Index

V

Vol 2-3

W

WARNINGS 5-1

MEMO