

---

## Preface

---

Thank you for purchasing Digital Electronics Corporation's T-Link I/F unit for GP units. This unit is used as the interface between the Fuji Electric Corporation's T-Link cable and Digital's graphical operation panel <Pro-face®> GP series units.

This manual describes the procedures and settings used when setting up data communication between T-Link and GP units. Of course, before operating your GP unit, please review section "1-1 Prior to Operating the GP" in your GP's User's Manual.

Here, the term "GP Series" includes the following models.

GP-\*50 series:                      GP450-EG\*\*, GP550-TC\*\*, GP550-SC\*\*, GPB50-RC\*\*

GP70 series:                        GP-470, GP-570, GP-570VM, GP-571, GP-675, GP-870

GP-477R/577R series

GP-2500/2600/2501/2601 series

GLC2500/2600 series

<Note>

1. It is forbidden to copy the contents of this manual, either in whole or in part, except for the purpose of the user's personal use, without the express written permission of the Digital Electronics Corporation of Japan.
2. The information provided in this manual is subject to change without notice.
3. This manual has been written with care, however, should the user discover any errors or omissions, please contact the Digital Electronics Corporation and inform them of your findings.
4. Please be aware that the Digital Electronics Corporation is not responsible for any damages resulting from the use of its products, regardless of article 3 above.
5. Note that the T-Link I/F unit does not support either the CE mark or UL standard. Therefore, please be careful when using the T-Link I/F with GP Series units that do support the CE mark or UL standard.

All company or manufacturer names used in this manual are the registered trademarks of their respective companies.

© Copyright May 1999, Digital Electronics Corporation

# Table of Contents

## Preface

Table of Contents .....	2
General Usage Cautions .....	4
GP Compatibility .....	5
Package Contents .....	6
Information Symbols .....	7

## Chapter 1 Overview

<b>1-1 T-Link System Overview .....</b>	<b>1-1</b>
<b>1-2 T-Link Data Transfer Cautions .....</b>	<b>1-2</b>
<b>1-3 Multiple GP Connection Limitations .....</b>	<b>1-2</b>
<b>1-4 Screen Creation Software Cautions .....</b>	<b>1-3</b>

## Chapter 2 Specifications

<b>2-1 T-Link Specifications .....</b>	<b>2-1</b>
<b>2-2 T-Link Unit Part Names and Functions .....</b>	<b>2-1</b>
<b>2-3 External Dimensions .....</b>	<b>2-2</b>
2-3-1 GP-470 Series Unit Installation Dimensions .....	2-2
2-3-2 GP-570 Series Unit Installation Dimensions .....	2-3
2-3-3 GP-450 Series Unit Installation Dimensions .....	2-4
2-3-4 GP-550 Series Unit Installation Dimensions .....	2-5
2-3-5 GP-B50 Series Unit Installation Dimensions .....	2-6

## Chapter 3 Installation and Wiring

<b>3-1 T-Link Unit Installation .....</b>	<b>3-1</b>
<b>3-2 T-Link Unit Wiring .....</b>	<b>3-3</b>
<b>3-3 T-Link Address Settings .....</b>	<b>3-4</b>

## Chapter 4 PLC Connection Information

<b>4-1 System Structure and Supported Devices .....</b>	<b>4-1</b>
4-1-1 System Structure .....	4-1
4-1-2 Supported Devices .....	4-2
<b>4-2 Maximum Number of Consecutive Addresses .....</b>	<b>4-5</b>

**Chapter 5 Error Handling**

**5-1 Troubleshooting**..... 5-1

    5-1-1 Possible Problems ..... 5-1

    5-1-2 No Screen Display (All GPs except GP-B50) ..... 5-3

    5-1-3 No Screen Display (Only GP-B50)..... 5-6

    5-1-4 No GP/Host Communication ..... 5-9

    5-1-5 Touch Panel Does Not Respond ..... 5-12

**5-2 Self-Diagnosis (GP and T-Link) ..... 5-13**

**5-3 Error Messages**..... 5-14

    5-3-1 Error Message List ..... 5-14

    5-3-2 Error Message Details..... 5-15

**Index**



## General Usage Cautions

For the safe and correct use of the T-Link I/F and GP series, be sure to follow the guidelines stated below.

- Due to the possibility of an electrical shock, be sure that the power supply for the GP is not plugged in when installing the T-Link I/F unit.
- Do not attempt to modify or alter the T-Link I/F unit. Doing so may cause a fire or an electric shock.
- To prevent the danger of either personal injury or machinery/material damage, please design your machine's control system so it will not malfunction due to a communication problem between the GP and host controller (PLC).

### To Avoid Damaging the T-Link I/F Unit:

- Do not allow water, liquids, or metal particles to enter into the T-Link I/F unit's case, since it can cause a malfunction or electrical shock.
- Avoid storing or operating the T-Link I/F unit in locations where it will be exposed to direct sunlight, high temperature, excessive dust, or vibration.
- Because the T-Link I/F unit is a precision instrument, do not store or operate it in locations where something may strike or hit the unit.
- Do not store or operate the T-Link I/F unit where chemicals or acids are stored, or where high concentrations of fumes are present.
- Do not use paint thinner or organic solvents to clean the T-Link I/F unit. Instead, soak a soft cloth in a diluted neutral detergent, wring it tightly, and then wipe the unit.
- Due to the danger of unforeseen accidents, be sure to back up all screen data regularly.
- This unit is not compatible with Fuji Electric's PLC FLEX-PC series units.
- When using a GP-\*50 series unit, be sure to use GP-PRO II Ver. 3.21 or higher screen editor software to ensure compatibility with the T-Link unit.
- To transmit screen creation software data to the GP, use Digital's optional data transfer cable.

# GP Compatibility

---

### <When using GP-470/570 series units>

- Screen data created for GP-\*30/50 series units using the GP-PRO II software can also be used. Use the GP-PRO/PB III (Windows or DOS version) software to import and convert older GP-PRO files.

**Reference** *GP-PRO/PB III Operation Manual (DOS); 3-2-3 GP-PRO Import GP-PRO File*  
*GP-PRO/PB III for Windows Operation Manual; 15.1 File Conversion*

- Screen data created for GP-\*10 series units cannot be used.

### <When using GP-\*50 series units>

- Screen data created for GP-\*30 series units can also be read. First, use the "F7 Setup" command to change the GP-PRO II project file's GP type to GP-450 or GP-550, and then open the file.

**Reference** *GP-PRO II Operation Manual*

- Screen data created for GP-\*10 series units (i.e. GP-PRO software's screen data) can also be used. Use GP-PRO II to convert the GP-PRO screen data to GP-\*50 series data.

**Reference** *GP-PRO II Operation Manual/ 3.1 Converting GP-\*10 Data to GP\*30 or GP\*50 Data*

## Package Contents

The T-Link I/F unit's packing box should contain the items listed below. Please confirm that everything illustrated here has been included.

■ **T-Link I/F unit**

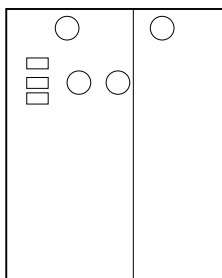

■ **T-Link connector (1)**

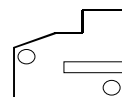

■ **GP-\*50/70 Series T-Link I/F Unit User's Manual (this manual)**

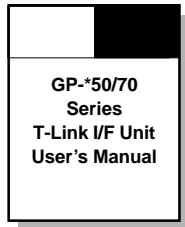

## Information Symbols

---

The list below describes the symbols and abbreviations used in this manual.



Indicates a potentially hazardous situation which could result in serious injury or even death, if the instructions are not followed.



Indicates a potentially hazardous situation which could result in minor injury or equipment damage if the instructions are not followed.



Explains a situation that requires a moderate amount of user caution.

**GP-PRO II**

Indicates the GP screen editing/creation software, GP-PROII.

**GP-PRO III**

Indicates the GP screen editing/creation software, GP-PRO III.

**GP-PRO/PB III**

Indicates the GP screen editing/creation software, GP-PRO/PBIII (DOS) and GP-PRO/PBIII for Windows.

**Screen Editor**

Refers to the GP-PROII, GP-PRO III and GP-PRO/PB III (DOS and Windows) software.

**PLC**

Programmable Logic Controller

\*1

Indicates supplemental explanatory information is located nearby, usually at the bottom of the page.



Indicates additional, relevant information.

**Reference**

Reference pages of related sections and topics.

**1) 2)**

Indicates step numbers. Operate the unit by following these numbers to perform the particular task.

---

# *MEMO*

This page intentionally left blank.



# Chapter 1

# Overview

- 1-1 T-Link System Overview
- 1-2 T-Link Data Transfer Cautions
- 1-3 Multiple GP Connection Limitations
- 1-4 Screen Creation Software Cautions

This chapter describes both the features of the T-Link I/F unit and how to set up communication between the T-Link unit and the GP.

## 1-1 T-Link System Overview

Using the T-Link I/F unit allows a GP unit to be connected directly to a Fuji Electric PLC via the T-Link cable.

Also, the creation of an “initial file” to designate the PLC's data transmission type and the entering of GP communication settings (via the "SET UP SIO" menu in the GP's SET UP I/O area) are not necessary.

Use the T-Link I/F unit's rotary switch to designate its address.

**Reference** 3-3 T-Link Address Settings

### <When using a T-Link I/F Unit>

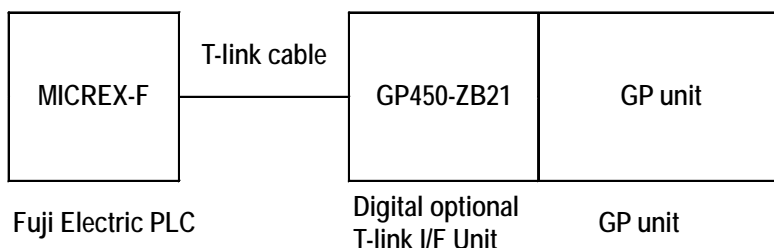

### <When not using a T-Link I/F Unit>

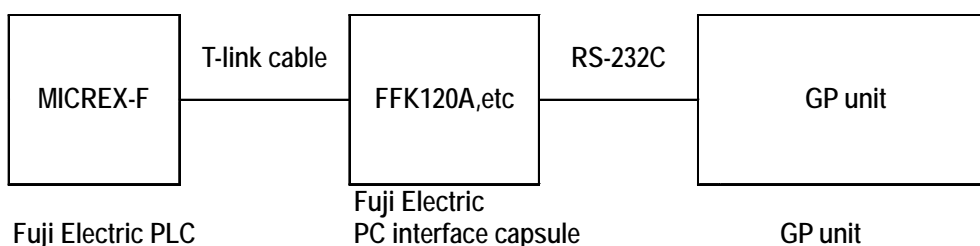

## 1-2 T-Link Data Transfer Cautions

With the GP connected to the PLC via the T-Link I/F unit, if the GP's power is turned OFF or it is reset (i.e. GP Reset is performed via a T-tag, auxiliary input/output's reset input, etc.), T-Link communication stops. When communication stops, a fatal error (ALM 1) occurs and the processor stops. To prevent this type of problem, use the PLC's Fault-Handler feature. This feature allows you to designate whether the PLC stops or continues to process data when T-Link communication stops for any reason. It allows you to treat an interruption as a Non-Fatal Error (ALM 2) and continue operation.

For detailed information about the Fault-Handler feature, refer to the appropriate Fuji Electric hardware manual.

## 1-3 Multiple GP Connection Limitations

Regardless of the T-Link unit specification's designated maximum number of GPs that can be connected, this number has a physical limit.

Considering the GP's screen display and operation response speeds, approximately 3 GP units should be the maximum connected.

The theoretical maximum number of the GPs that can be connected to the T-Link I/F unit, without connecting other equipment such as a program loader or POD (programmable operation display), are as shown below.

PLC Name	Maximum Number of Connectable GPs
F30, F50	3
F60, F80, F81, F100	3
F120	3
F80H	3
F120H	6
F120S, F140S, F150S	64
F200	5
F250	8
F70S	32



- **When a program loader or a Fuji Electric's POD UD series device is connected to the T-Link I/F unit, the Connectable GP numbers shown here will be reduced.**  
**For further information, please contact your local Fuji Electric distributor.**
- **As the number of connected GPs increases, the GP's screen display and operation response speeds will decrease.**

### 1-4 Screen Creation Software Cautions

When selecting a screen editor project's PLC Type, be sure to select "FUJI MICREX-F SERIES (T-Link)".

For PLC Type selection procedures, refer to each screen editor software's Operation Manual.

#### **Reference**

*GP-PRO II Operation Manual; 2.2.1 Host PLC*

*GP-PRO III Operation Manual; 1-5-2 Select GP Model and PLC Type*

*GP-PRO/PB III Operation Manual (DOS); 1-5-2 Select Project*

*GP-PRO/PB III for Windows Operation Manual; 1-7-2 Creating/Selecting/Saving a Project*

# *MEMO*

This page intentionally left blank.

This chapter describes the specifications, names, and figures for the T-Link I/F unit.

## 2-1 T-Link Specifications

Number of channels	Single T-link channel
Input/output type	MICREX-F T-link
Data transmission speed	500Kbps
Specified Connector	T-link connector

## 2-2 T-Link Unit Part Names and Functions

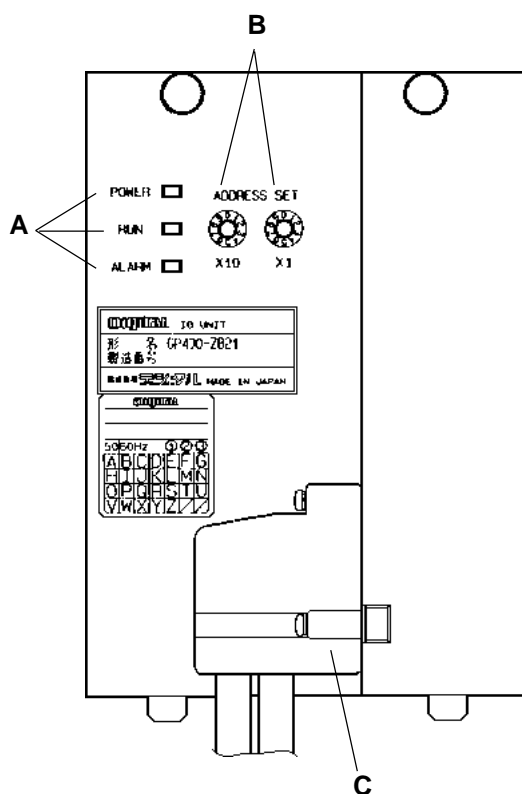

### A: Indicator LED

Indicates the T-Link I/F unit status.

Indicator	Color	Status
POWER	Green	Power is ON
RUN	Green	Connected to PLC (Data Transfer can be performed)
ALARM	Red	Memory error

### B: T-Link Address Setting Switches

Designates the MICREX-F T-Link channel number. Address can be from 00 to 99.

### C: T-Link Terminal Block

Connect the MICREX-F T-Link cable here.

## 2-3 External Dimensions

Outside drawings of the GP with the T-Link I/F unit attached are shown here.

The shaded part (■) in each drawing indicates the T-Link I/F unit.

### 1 GP-470 Series Unit Installation Dimensions

Unit: mm

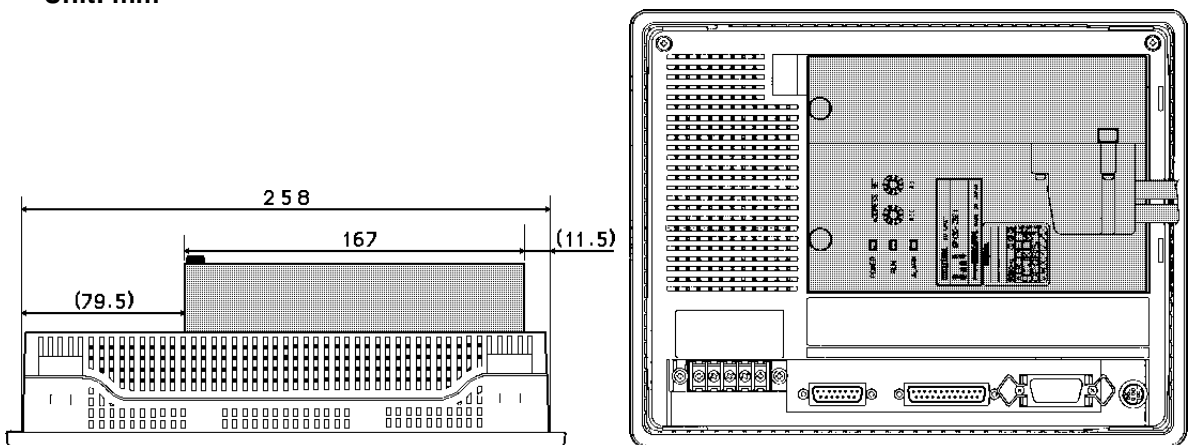

Top view

Rear view

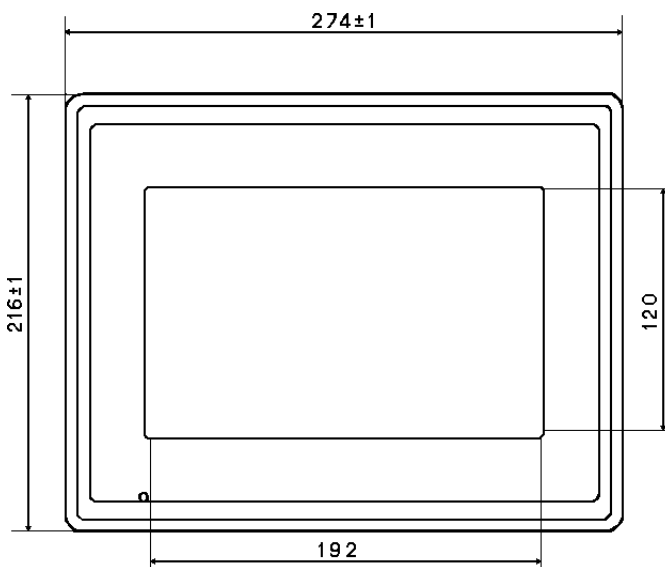

Front view

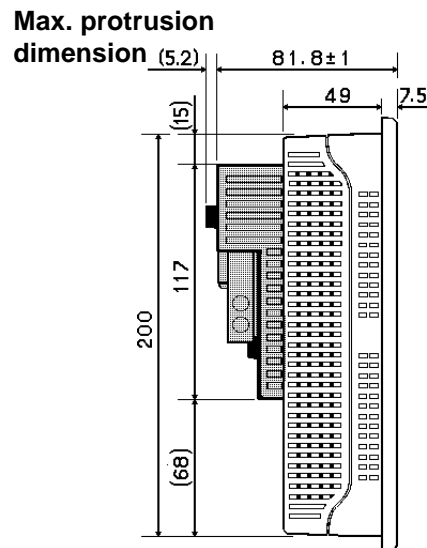

Side view

# Specifications

## 2 GP-570 Series Unit Installation Dimensions

Unit: mm

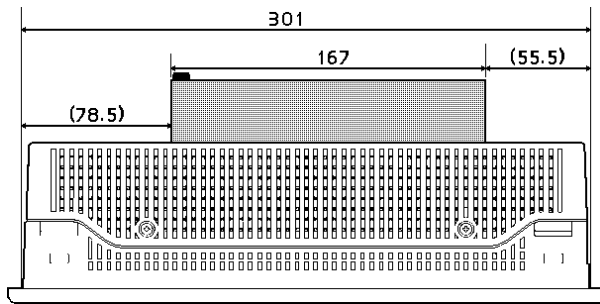

Top view

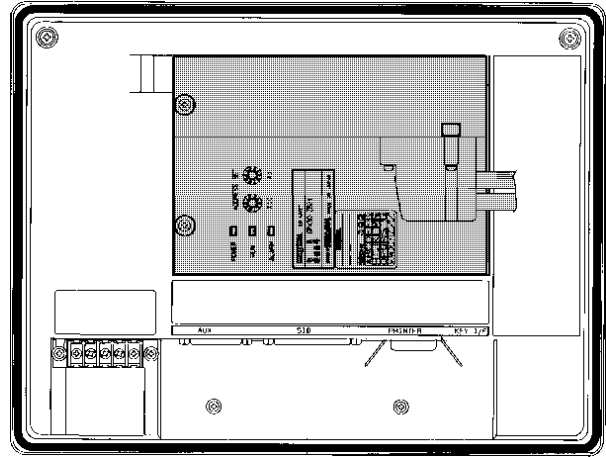

Rear view

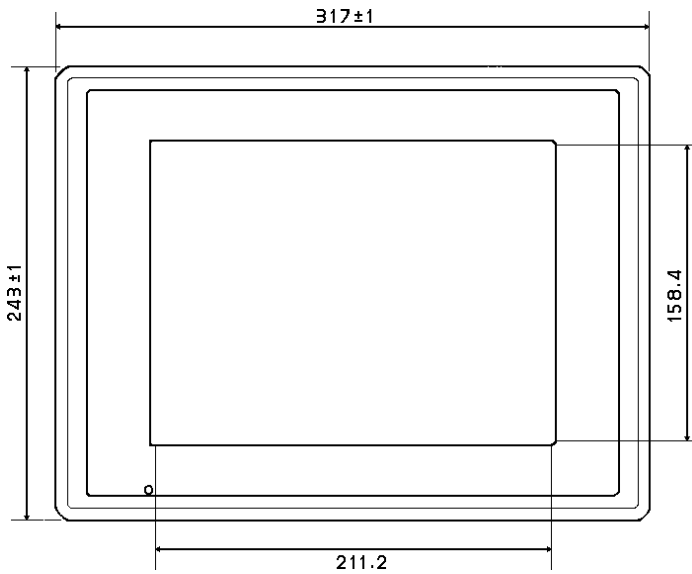

Front view

Max. protrusion dimension (5.2)

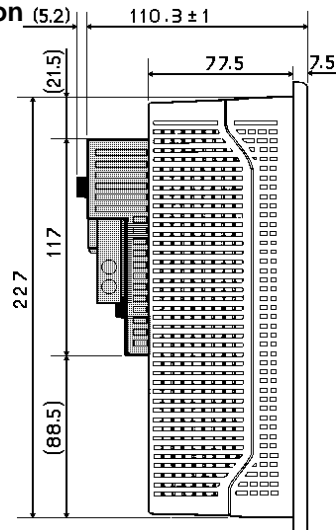

Side view

### 3 GP-450 Series Unit Installation Dimensions

Unit: mm

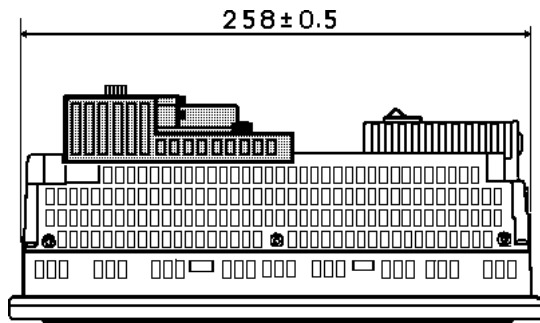

Top view

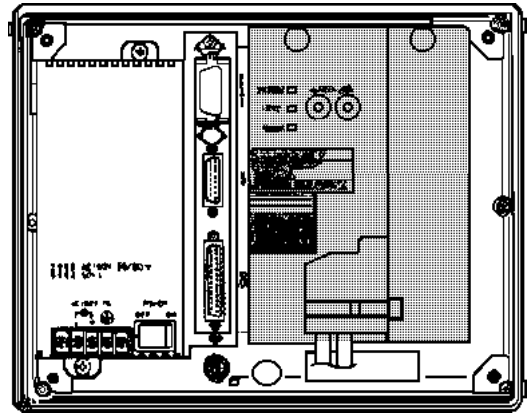

Rear view

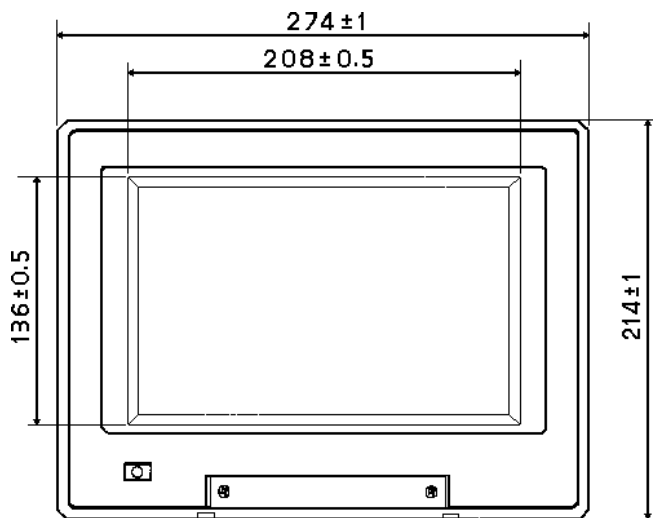

Front view

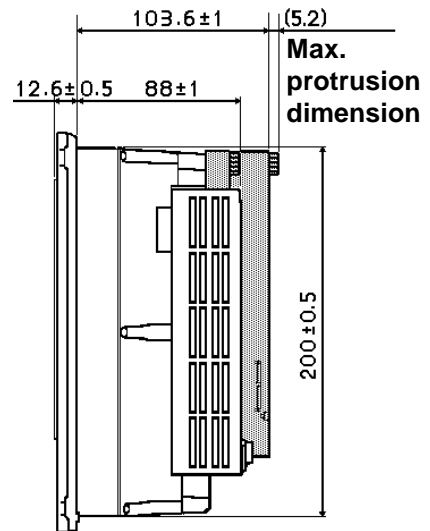

Side view

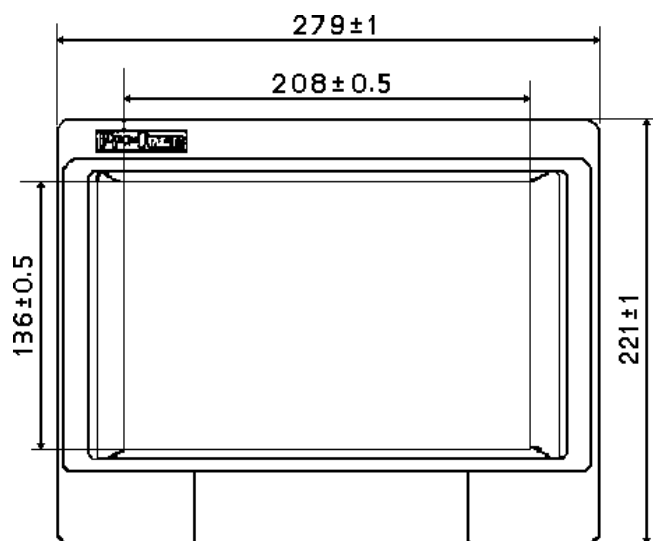

Front view (with cover panel)

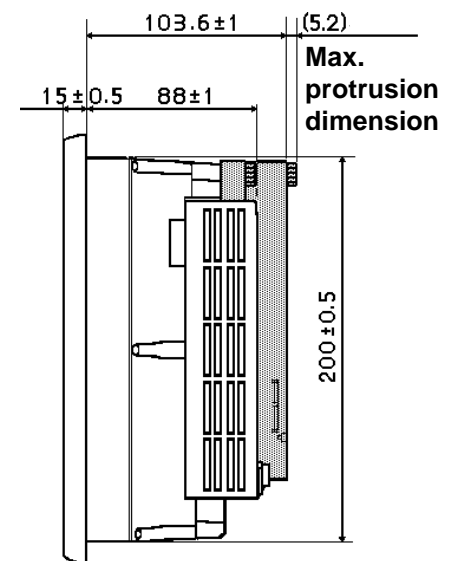

Side view (with cover panel)



## 4 GP-550 Series Unit Installation Dimensions

Unit: mm

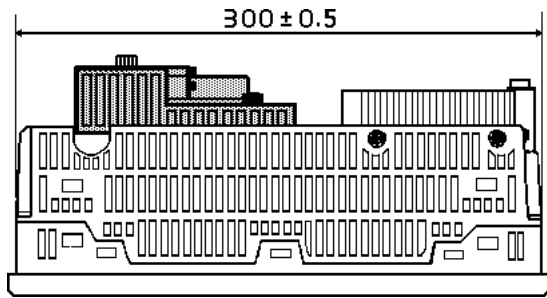

Top view

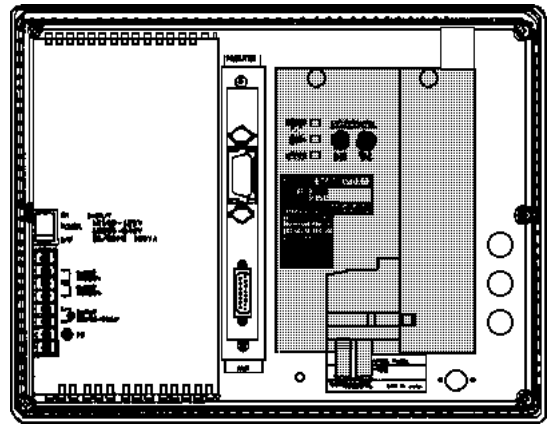

Rear view

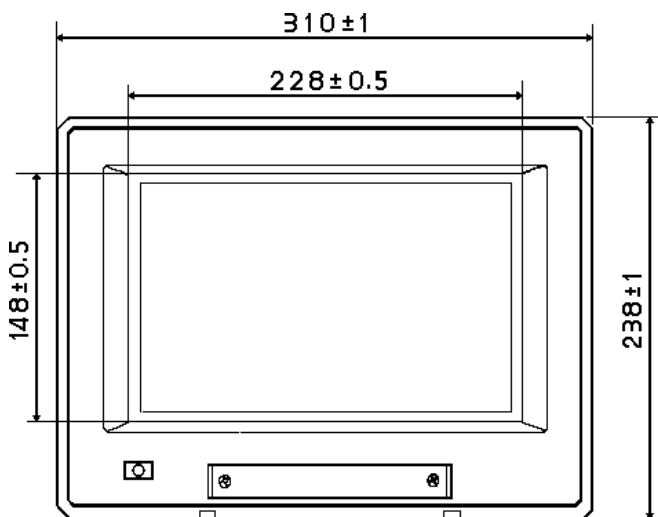

Front view

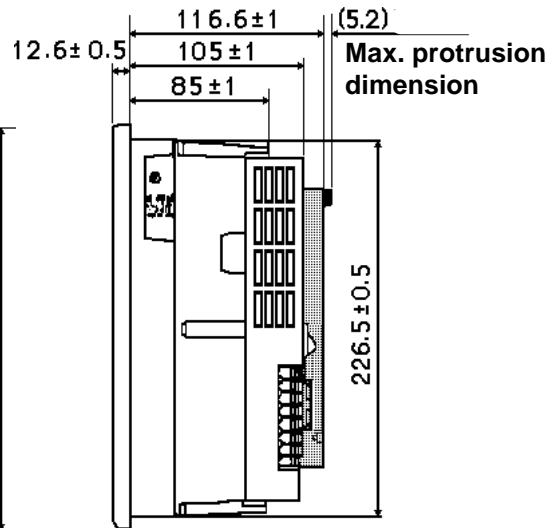

Side view

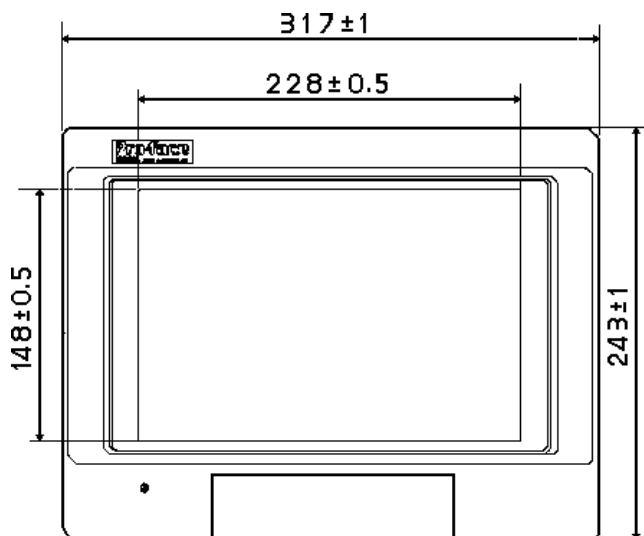

Front view (with cover panel)

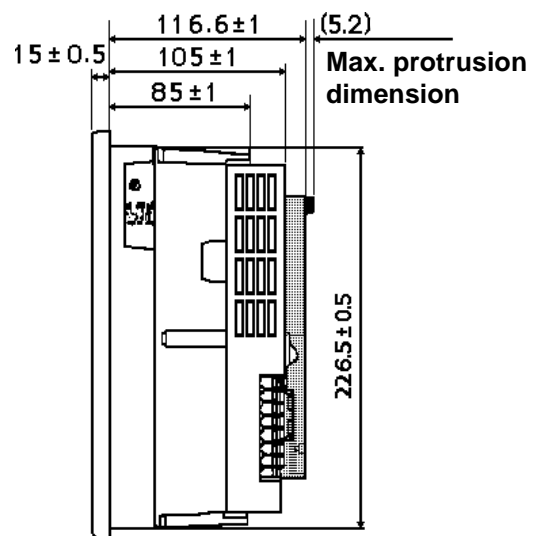

Side view (with cover panel)

## 5 GP-B50 Series Unit Installation Dimensions

Unit: mm

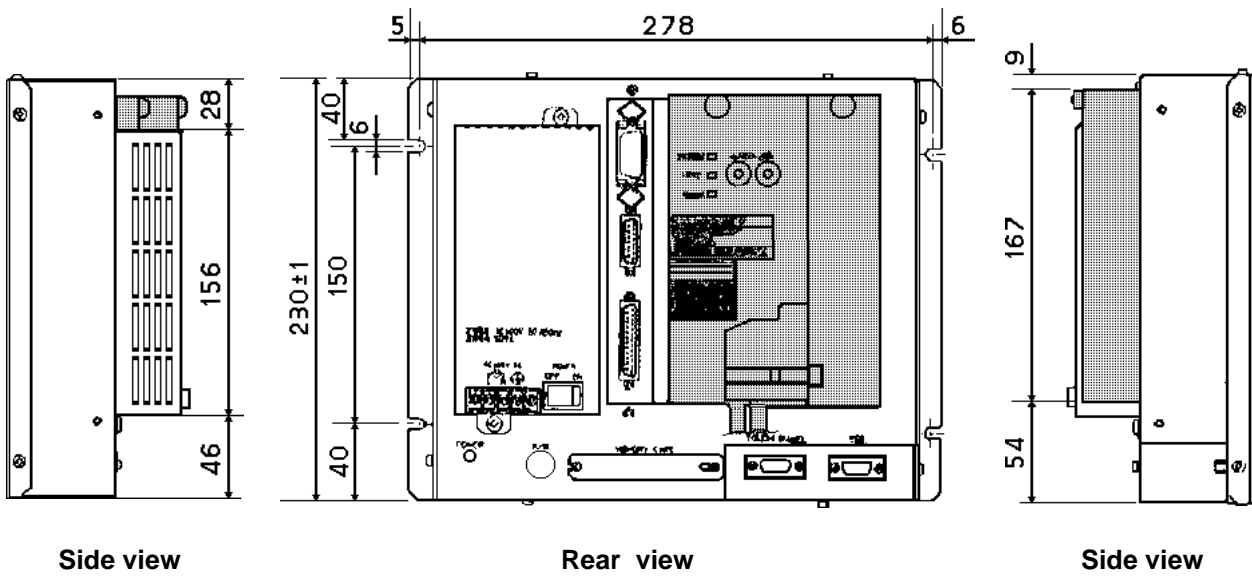
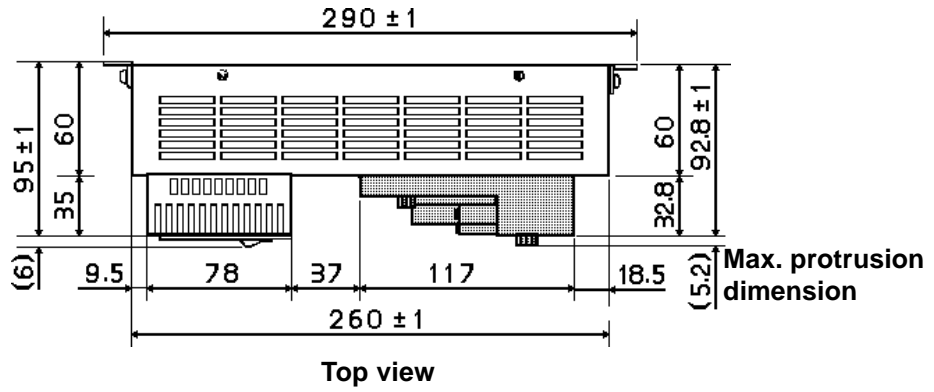

# Installation and Wiring

This chapter describes how to install and wire the T-Link I/F unit and how to set the T-Link I/F unit's address.

## 3-1 T-Link Unit Installation



### WARNING

- Due to the possibility of an electrical shock, be sure the GP's power cord is not plugged into the power supply when installing this unit.
- Be sure not to touch the interior surface of the printed circuit board.

1) When using a GP-\*70 unit, first, unplug the power cord from the power supply, and then unscrew the power cable terminals.

When using a GP-\*50 series unit, first, turn the power switch OFF and then unscrew the power cable terminals.

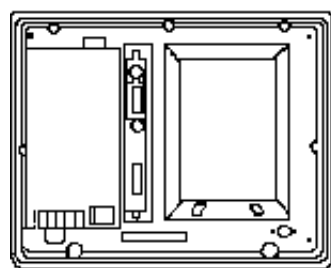

GP Rear Face



Rear Cover

2) Unscrew the Rear Cover's two (2) attachment screws, and remove the rear cover from the GP.

\* This example uses a GP-\*50 series unit.

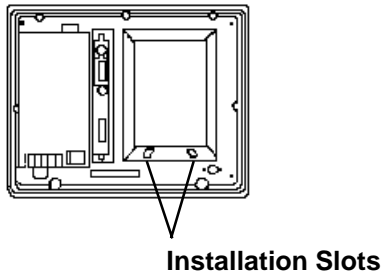
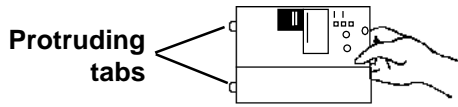

- 3) Insert the protruding tabs of the T-Link I/F unit into the installation slots. Be sure to install the unit so that the smooth metal surface faces outward.

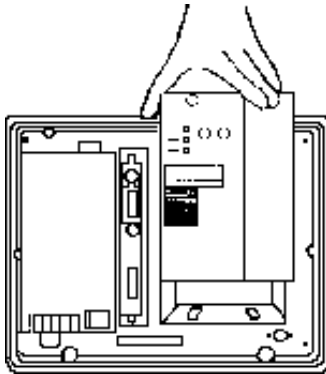

***Be careful not to touch the surface of the printed circuit board.***

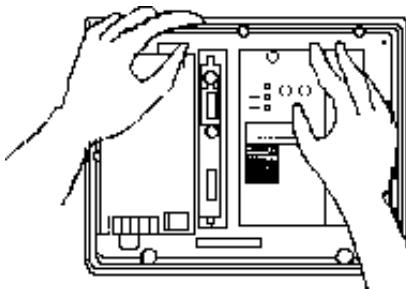

- 4) Hold the GP with your left hand and insert the T-Link I/F unit into its slot with your right hand. Insert the unit securely so that no gaps remain between the GP and the T-Link I/F unit.

Attachment Screws

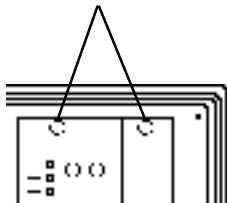

- 5) Secure the T-Link I/F unit in position with its attachment screws (included in package).

### 3-2 T-Link Unit Wiring

The following T-Link cables can be connected to the T-Link I/F unit. For detailed information, please refer to a Fuji Electric product catalogue.

#### Twisted pair cable

- CPEV-SB  $\phi$  0.9 x 1 pair (made by Furukawa Electric)  
Total extension length: 1,000m, max.
- KPEV-SB 0.5sq x 1 pair (made by Furukawa Electric)  
Total extension length: 700m, max.

Use the following procedure to wire the T-Link I/F unit.

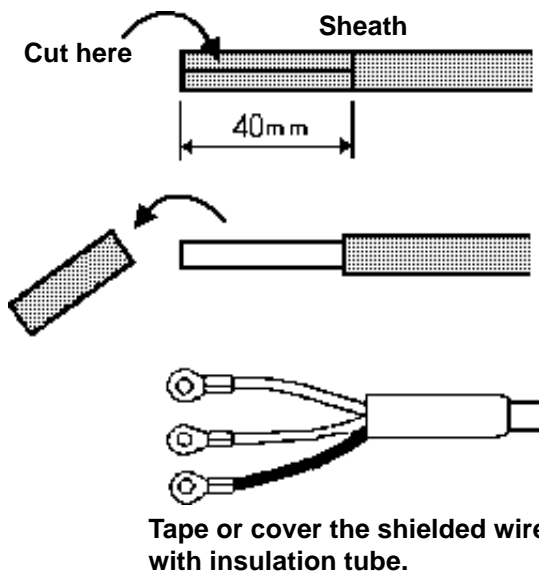

1) Lightly cut the cable's sheath.

2) Remove the sheath and expose the braided wires.

3) Use crimp-style ring terminals to crimp each wire.

Tape or cover the shielded wire with insulation tube.

When the GP is connected as a T-Link terminal

When the GP is connected at the end of the T-Link network

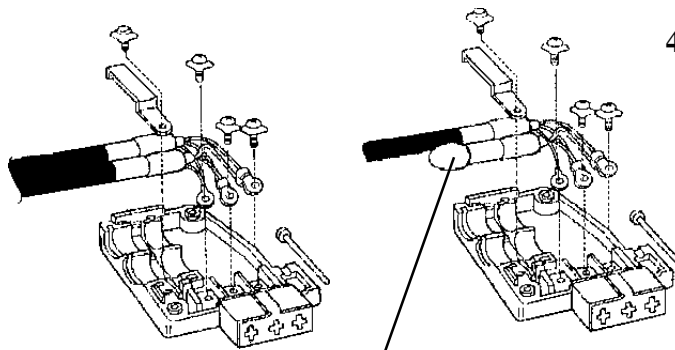

T-Link Termination resistor

4) Connect each wire to the T-Link connector.

When the GP is the terminating (first or last) unit in a network, connect the Fuji Electric PLC's 100 $\Omega$  resistor, as shown here.

# 3-3 T-Link Address Settings

When the GP and PLC are connected via the T-Link cable, the PLC's input/output area is used for 2 words. This area's location is determined by the T-Link Address' set value. To designate the T-Link Address, use the T-Link Address setting switch located on the rear of the T-Link I/F unit.

Also, inching output (Tih/Tiw-tag) data is sent to this area.

**Reference** For detailed information about inching output, refer to the *GP-PRO/PBIII Tag Reference Manual*

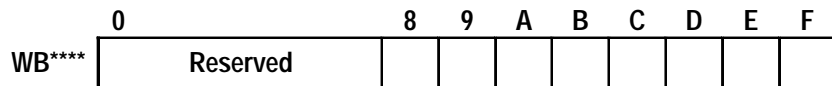

GP AUX I/F's Tsw 0 to 7 data is output.

Bit 8: Tsw 7

to

Bit F: Tsw 0

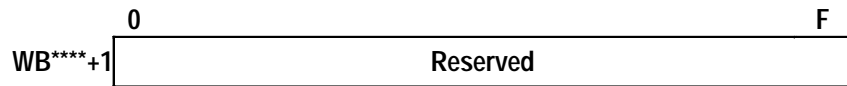

**Be sure the designated T-Link Address does not overlap any other I/O address.**

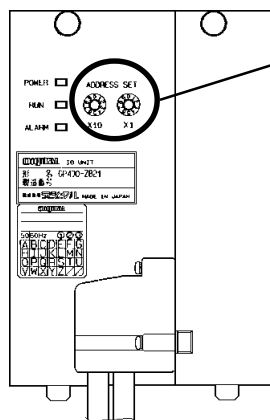

<E.g.> When setting the T-Link Address to "30":

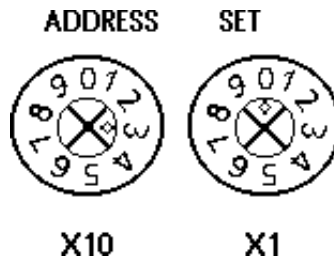

With the setting above, the PLC's input/output relays "WB0030" and "WB0031" are used.

# 4

## PLC Connection Information

This chapter describes PLC models manufactured by Fuji Electric and devices that can be connected to the GP via the T-Link I/F unit.

### 4-1 System Structure and Supported Devices

This section describes the configuration used to connect the GP and Fuji Electric's MICREX-F series via the T-Link cable.

#### 1 System Structure

MICREX-F series

GP series unit T-Link I/F unit

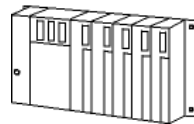

F80, F81, F100, F120  
 F80H, F120H  
 F70S, F120S, F140S, F150S  
 F200, F250  
 F30, F50, F60



**When a PLC model is updated or modified, the manufacturer may change the specifications so that the new model cannot be connected to the GP.**



**Note:** New PLC models will be added when this manual is updated.

## 2 Supported Devices

The devices that can be used with the GP are as follows.

**Bit 15** indicates that that device can designate the bit location. Attach the bit location (0 to 15) after a Word Address.

**Bit 31** indicates that that device can designate the bit location. Attach the 32 bit location (0 to 31) after a Word Address.

Word Addresses shown in   can be used in the system area.

Device	Bit Address	Word Address	Remarks
Input relay	B0000-B511F	WB0000-WB0511	*1
Direct input/output	-----	W24.0000-W24.0159	
Auxiliary relay	M0000-M511F	WM0000-WM0511	*1
Keep relay	K0000-K063F	WK0000-WK063	*1
Differential relay	D0000-D063F	WD0000-WD063	*1
Link relay	L0000-L511F	WL0000-WL511	*1
Timer (0.01 sec.)	T0000-T0511	-----	
Timer (0.1 sec.)	T0512-T1023	-----	
Counter	C0000-C0255	-----	
Timer (0.01 sec) (current value)	-----	TR0000-TR0511	
Timer (0.01 sec) (set value)	-----	TS0000-TS0511	
Timer (0.1 sec) (current value)	-----	W9.000-W9.511	
Counter (current value)	-----	CR0000-CR0255	
Counter (set value)	-----	CS0000-CS0255	
Data memory	-----	BD0000-BD4095	<b>Bit 31</b>
	-----	DI0000-DI4095	<b>Bit 31</b>
	-----	SI0000-SI4095	<b>Bit 15</b>
File memory	-----	W30.0000-W30.4094	<b>Bit 15</b> *2
	-----	W31.0000-W31.4094	<b>Bit 15</b> *2
	-----	W32.0000-W32.4094	<b>Bit 15</b> *2
	-----	W33.0000-W33.4094	<b>Bit 31</b> *3
	-----	W34.0000-W34.4094	<b>Bit 31</b> *3

H/L

\*1. A word device's highest bit corresponds to a bit device's Bit 0. Also, a word device's lowest bit corresponds to a bit device's Bit F.

<E.g.> When writing hexadecimal data "0001" to Address WB0002 (Word device):

B002*	(Bit device)	0	1	2	3	4	5	6	7	8	9	A	B	C	D	E	F
EB002	(Word device)	0	0	0	0	0	0	0	0	0	0	0	0	0	0	0	1

"1" is set to Address B002F (Bit device)

\*2. Be sure to use only 16 bit data in this area.

\*3. Be sure to use only 32 bit data in this area.



## PLC Connection Information



16 bit word data is processed in the GP's system data area. When performing processing here, select W30, W31, W32, or SI.

<E.g.> When changing screens:

To write a constant to the system data area's Address +8, be sure to use "Set 16 B"



Please be aware that symbols used for direct input/output and file memory are different in the PLC's manual from GP-PRO II.

<E.g.>

The GP's internal processing is normally performed using "word" data that is 16

GP-PRO II	PLC
W240000	W24.0000



bits long. Therefore, with devices that use 32 bit length data, data read and write are performed as follows, except when using N- and K-tags.

When reading data: The lower 16 bit data is read.

When writing data: Data is written to the lower 16 bits, and "0" is written to the upper 16 bits.

<E.g.> When data is "12345678HEX":

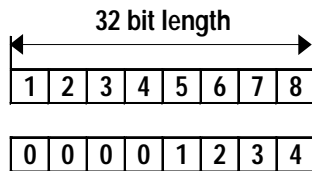

<When reading data:>

The lower 16 bits, i.e. "5678HEX" is read.

<When writing data:>

"0" is written to the upper 16 bits and "1234HEX" is written to the lower 16 bits.



The Numeric display 8 digit BCD displays and K-tags both support devices using 32 bit data.

While two (2) Word Addresses are used to process 32 bit data in a 16 bit device, a 32 bit device can process 32 bit data using only 1 Word Address.

<E.g.> When the data is "12345678HEX":

16 bit device

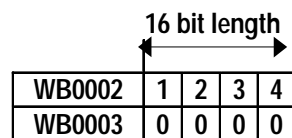

With the N-tag's 8 digit BCD display and K-tags, 32 bit data is processed using 2 Word Addresses.

32 bit device

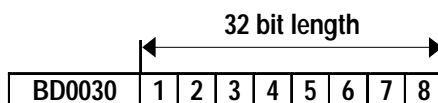

With the N-tag's 8 digit BCD display and K-tags, 32 bit data is processed using only 1 Word Address.



**The LS area does not support 32 bit devices.**

Since the LS area uses only 16 bit data, if an S-tag, N-tag, or K-tag's Designated Address is designated as in the LS area and that area is later used by a different device, an unexpected GP operation may be performed.

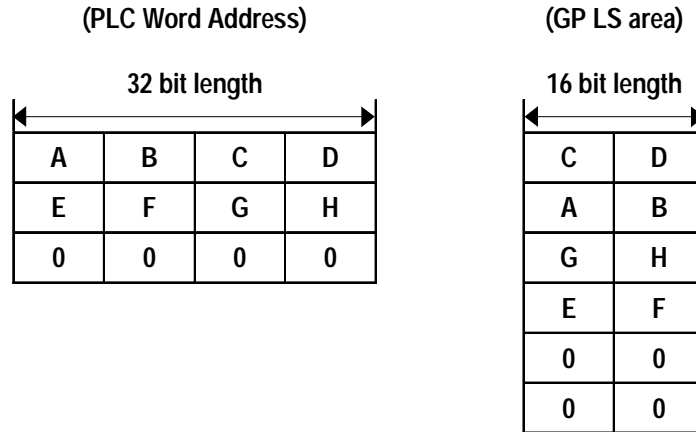

Display on a GP unit is "C," "D," "A," "B," "G," "H," "E," and "F."



**When using GP-\*50 series data that was converted from GP-\*10 series data, the GP may perform unexpectedly.**

**Reference**

For information about converting GP-\*10 series data to GP-\*50 series data, see the *GP-PRO II Operation Manual; 8.1 Converting GP-\*10 Files.*

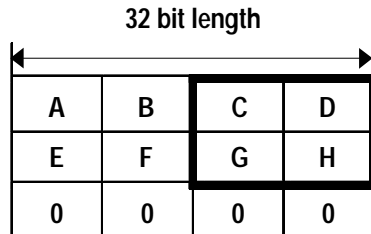

The display on a GP-\*10 series unit is "C," "D," "G," and "H."  
(Lower 16 bit data is displayed)



Then, converted to GP-\*50 series data.

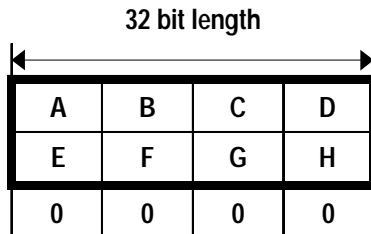

Appears on a GP-\*50 series unit as "C," "D," "A," "B," "G," "H," "E," and "F."  
(32 bit data)

### 4-2 Maximum Number of Consecutive Addresses

The following is the maximum number of words available when reading continuous Address data. Refer to this information when transmitting data in blocks.

Device	Continuous Address Maximum No. of Words	Device	Continuous Address Maximum No. of Words
Input/output relay B	48 words	Timer (0.1 sec.) (current value) W9	24 words
Auxiliary relay M		Counter (current value) CR	
Keep relay K		Counter (set value) CS	
Differential relay D		Data memory BD	
Link relay L		Data memory DI	
Timer (0.01 sec.) T	1 word	Data memory SI	48 words
Timer (0.1 sec.) T		File memory (W30)	
Counter C		File memory (W31)	
Direct input/output W	48 words	File memory (W32)	
Timer (0.01 sec.) (current value) TR	24 words	File memory (W33)	24 words
Timer (0.01 sec.) (set value) TS		File memory (W34)	

*MEMO*

This page intentionally left blank.

## 5-1 Troubleshooting

The following section describes how to find the causes of troubles and how to resolve them.

### 1 Possible Problems

Possible problems that could occur while operating the GP are as follows:

**(1) No screen display**

When power supply switch is turned on but screen displays nothing. Screen display fades out during operation.

**(2) No communication**

Data communication does not function between the GP and Host. In some cases, an error message will be displayed on the screen.

**▼Reference▲** For error messages, refer to “5-2 Detailed Information on Error Messages,” and the respective *User’s Manuals*.

**(3) No response when using the touch panel**

There is no response, or very slow response, when pushing the touch panel.

**(4) OFFLINE mode is displayed during operation.**

For (1) to (3) above, the process for troubleshooting is shown on the following pages using flowcharts.

For (4) above, the cause of displaying OFFLINE mode may be due to a system error.

**Reference** Refer to “5-2 Detailed Information on Error Messages,” and the respective *User’s Manuals*. (However, one exception is that *OFFLINE* mode will display if you touch the upper left corner of the screen within 10 seconds after start-up.)



### WARNING

- Before wiring the T-Link unit, due to the possibility of an electrical shock, be sure the GP’s power cord is unplugged from the power supply .
- When replacing the GP’s backlight, due to the possibility of an electrical shock or burn, be sure to first unplug the power cord and wear gloves before performing any wiring.



This chapter describes problems related to the GP unit, and assumes there are no PLC problems. For PLC troubleshooting information, please refer to that PLC maker’s Operation Manual.

## 2 No Screen Display (All GPs except GP-B50)

Use the flowchart below to diagnose why there is no display after the GP's power cable is connected, or, the screen turns OFF during RUN mode.

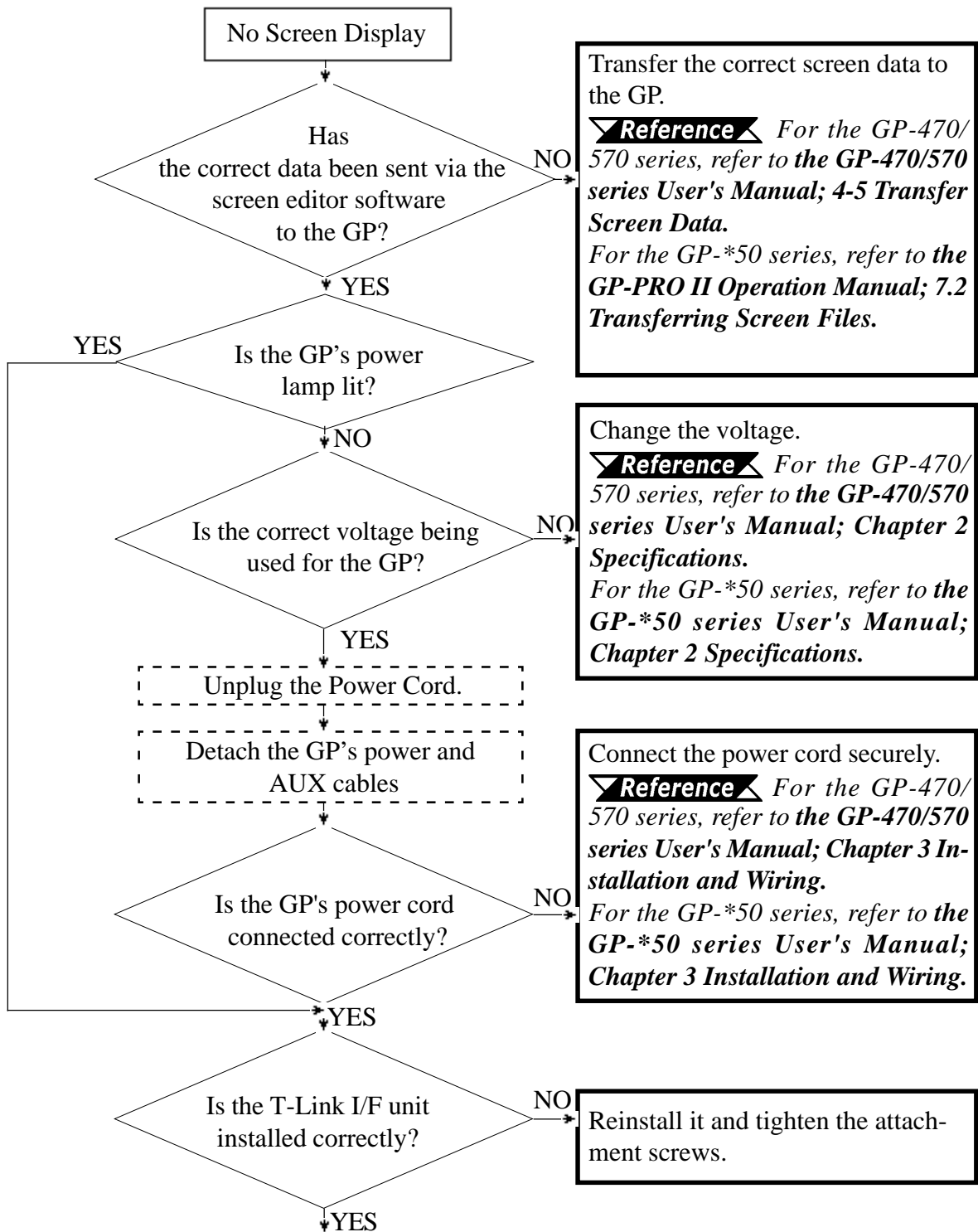

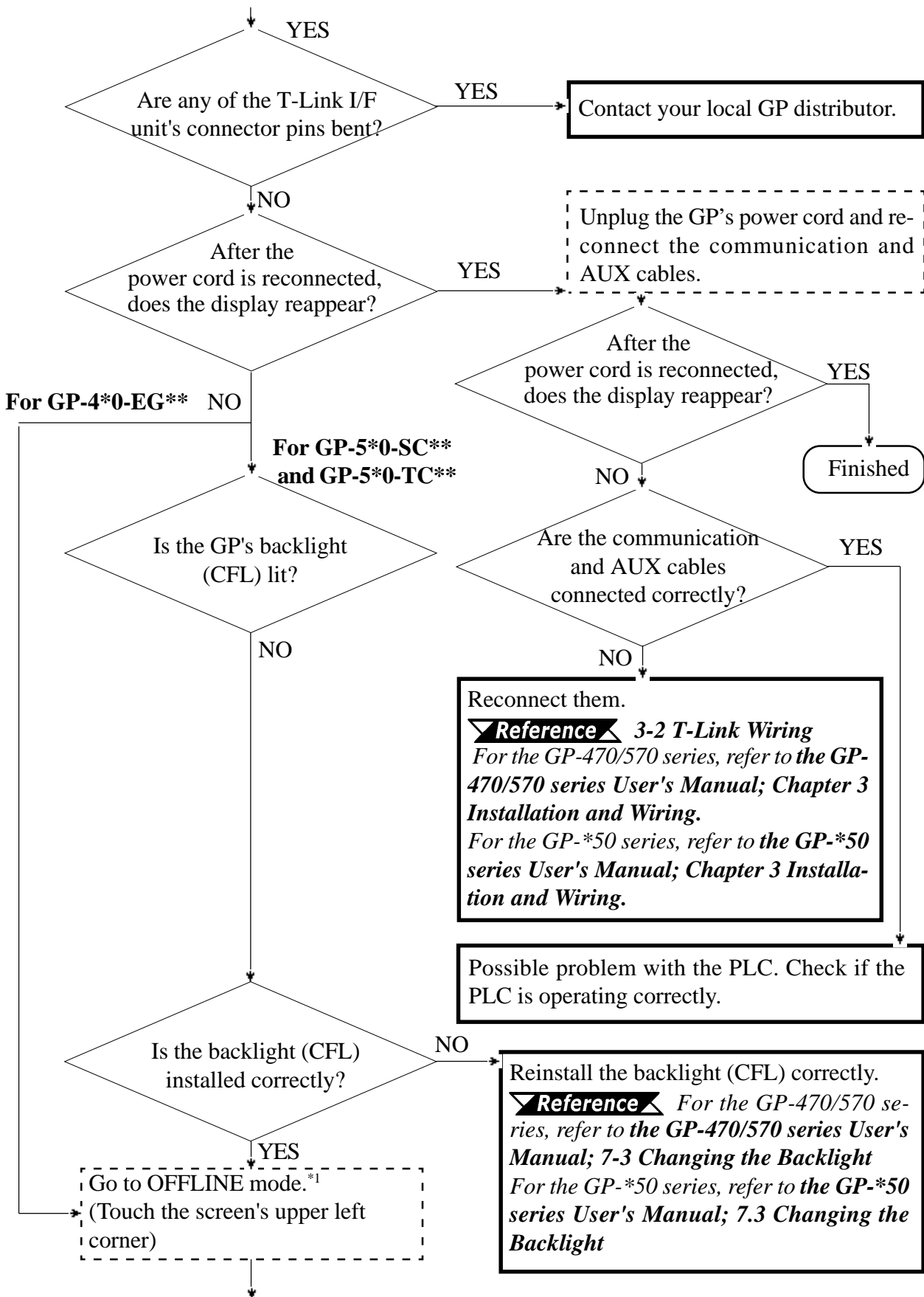



## Error Handling

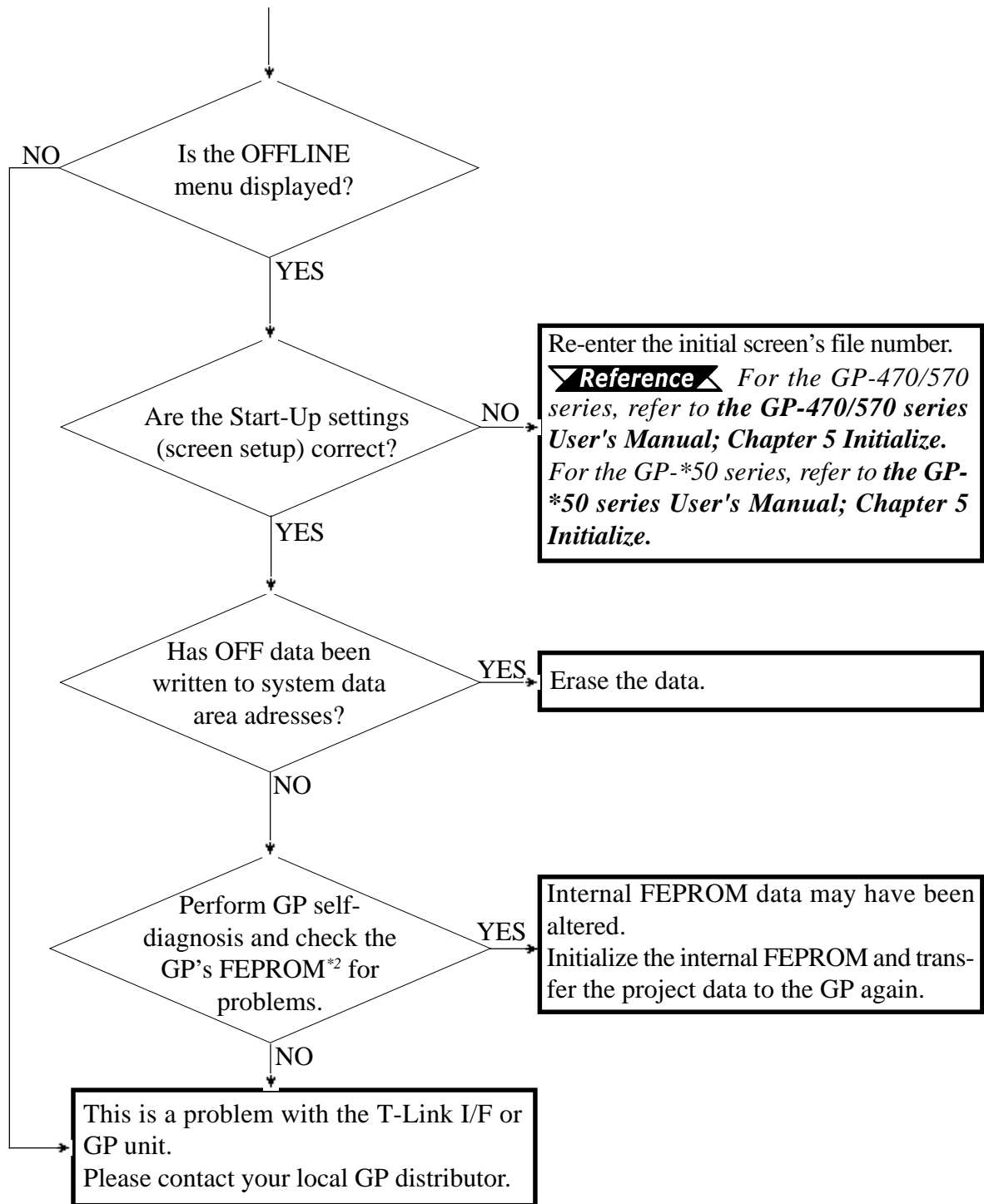

\*1 To make the GP's OFFLINE screen appear, disconnect the power cord, reconnect it, then touch the upper left corner of the screen within 10 seconds of reconnecting the power cord.

\*2 Running the FEPRM check will erase all the current screen data. Be sure to make a backup of all screen data prior to running this check.

### 3 No Screen Display (Only GP-B50)

Use the flowchart below to diagnose why no display appears after the GP's power cord is connected, or when the screen turns OFF during RUN mode.

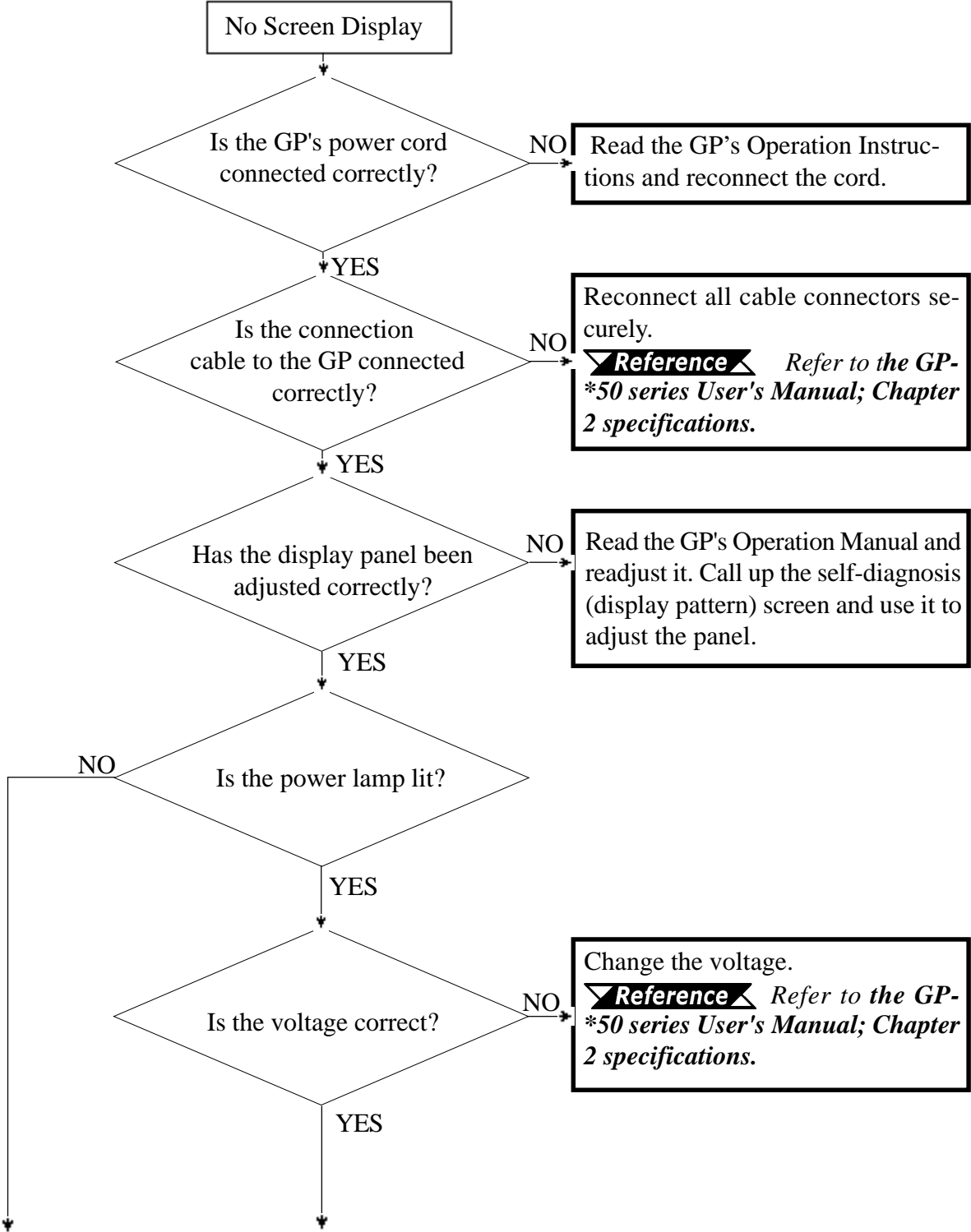

## Error Handling

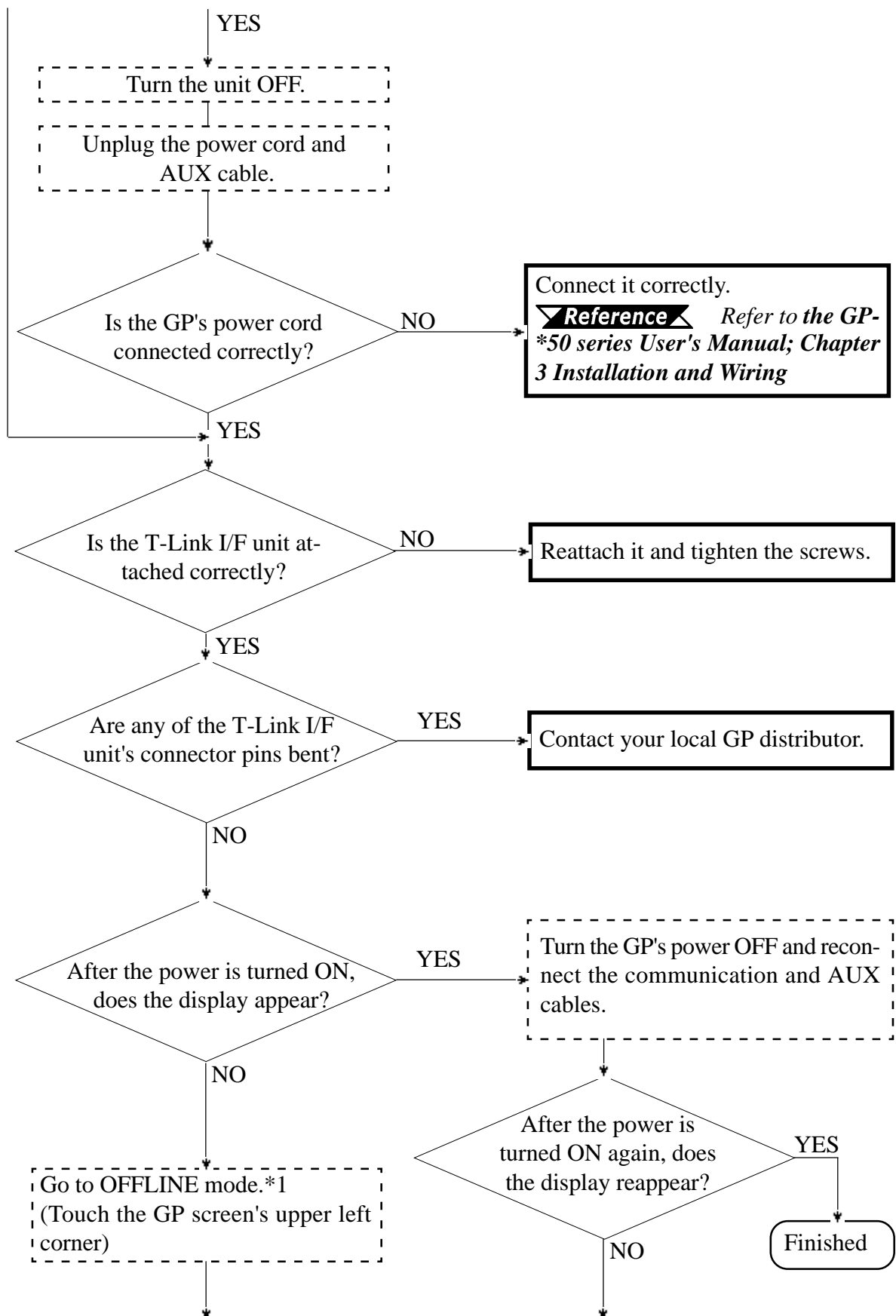

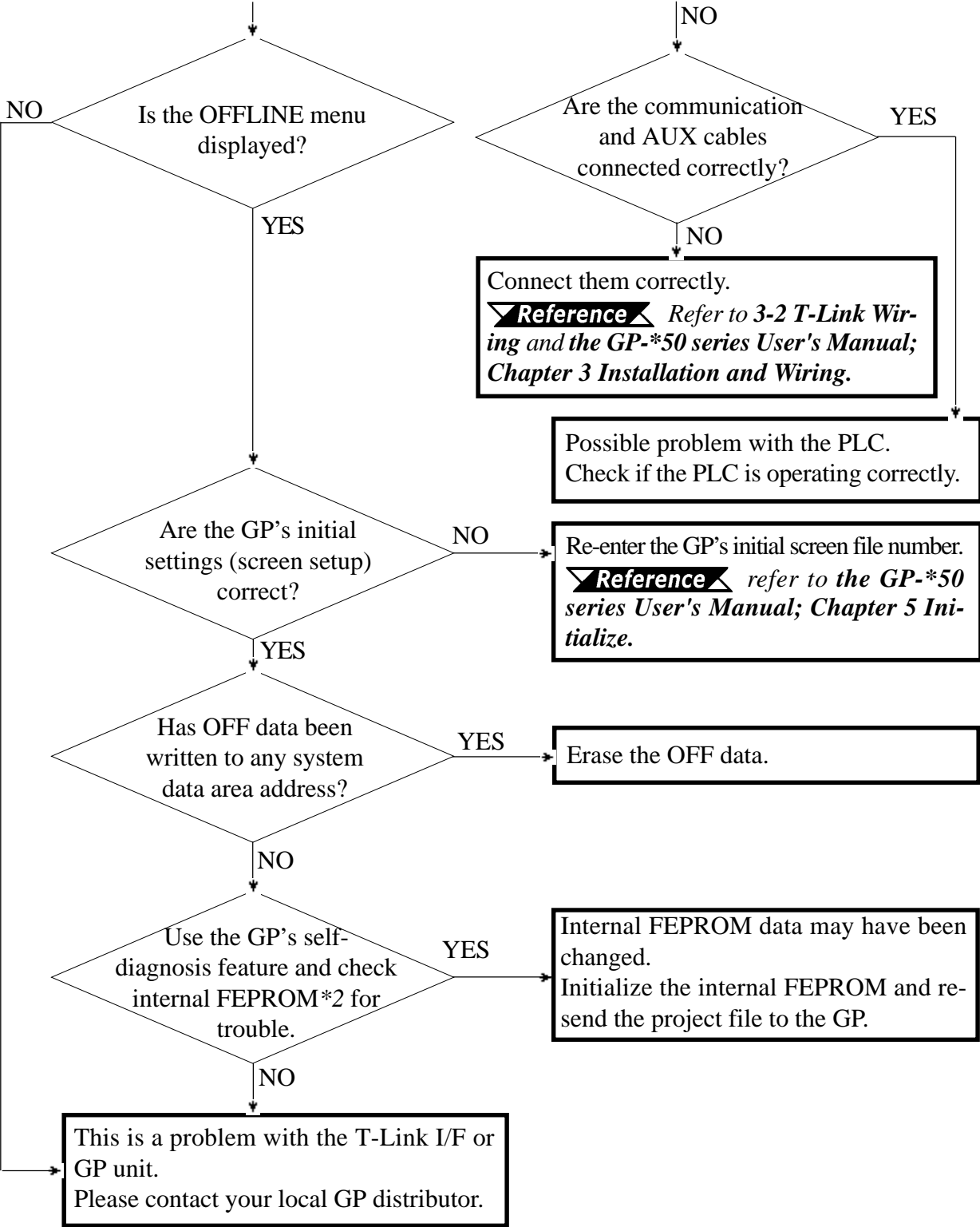

\*1 To make the GP's OFFLINE screen appear, disconnect the power cable, reconnect it, then touch the upper left corner of the screen within 10 seconds of reconnecting the power cable.

\*2 Running the FEPRM check will erase all the current screen data. Be sure to make a backup of all screen data prior to running this check.

## 4 No GP/Host Communication

If the GP cannot communicate with the host, use the flowchart below to find the cause of the trouble and an appropriate solution.

If an error message is displayed on the GP screen, check the error code list and follow the instructions for that message.

**Reference** Refer to “5-2 Detailed Information on Error Messages,” and the respective *User’s Manuals*.

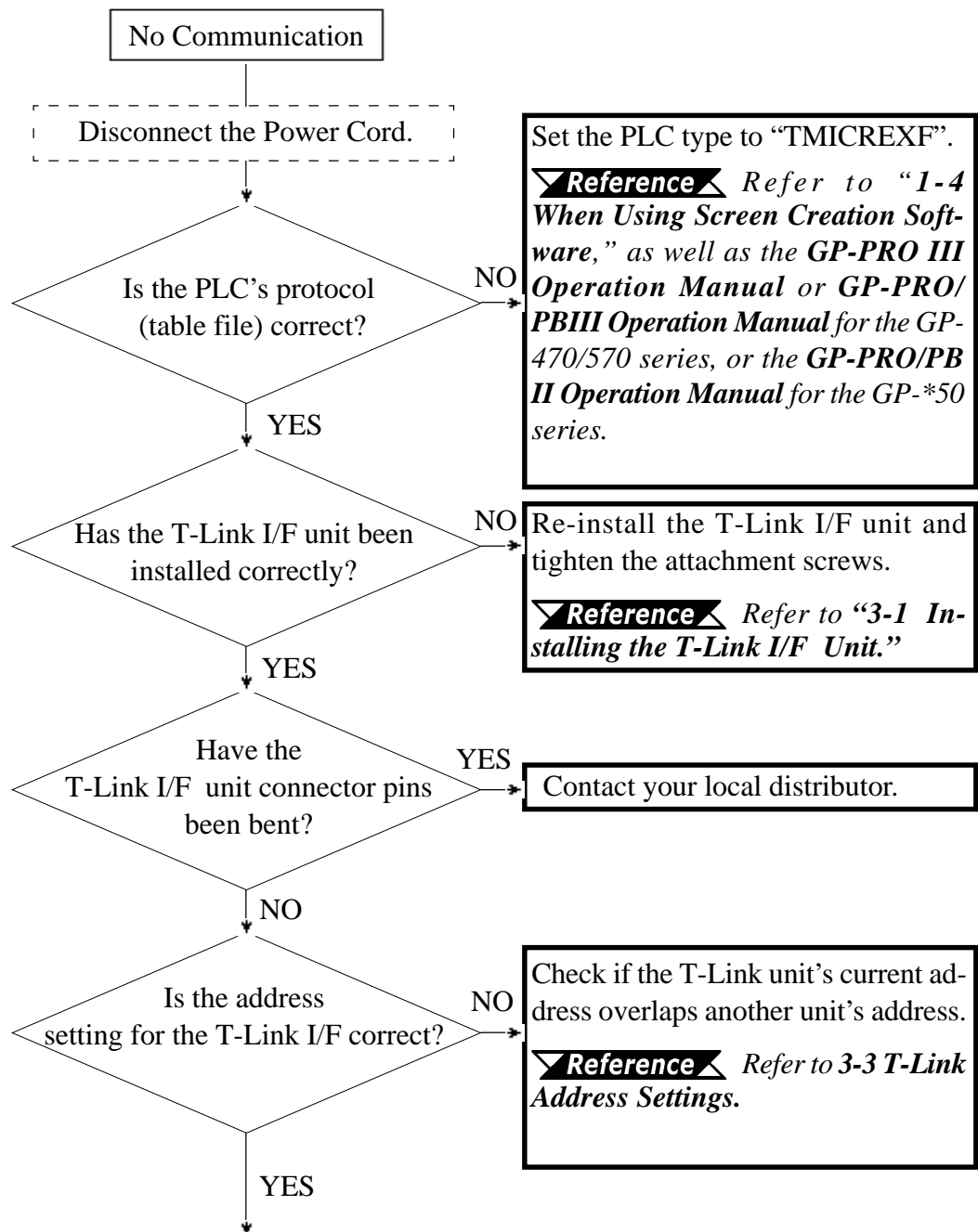

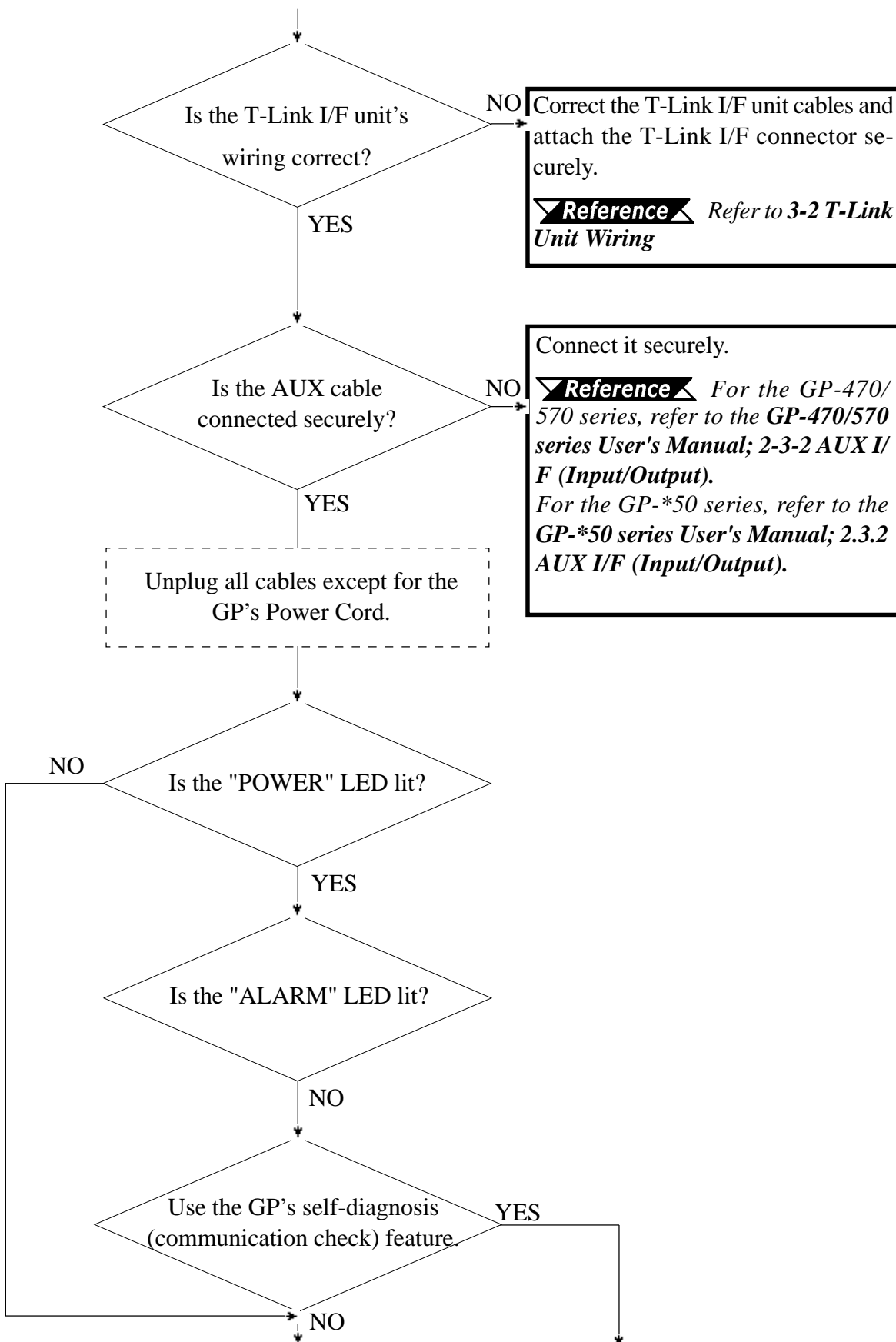

## Error Handling

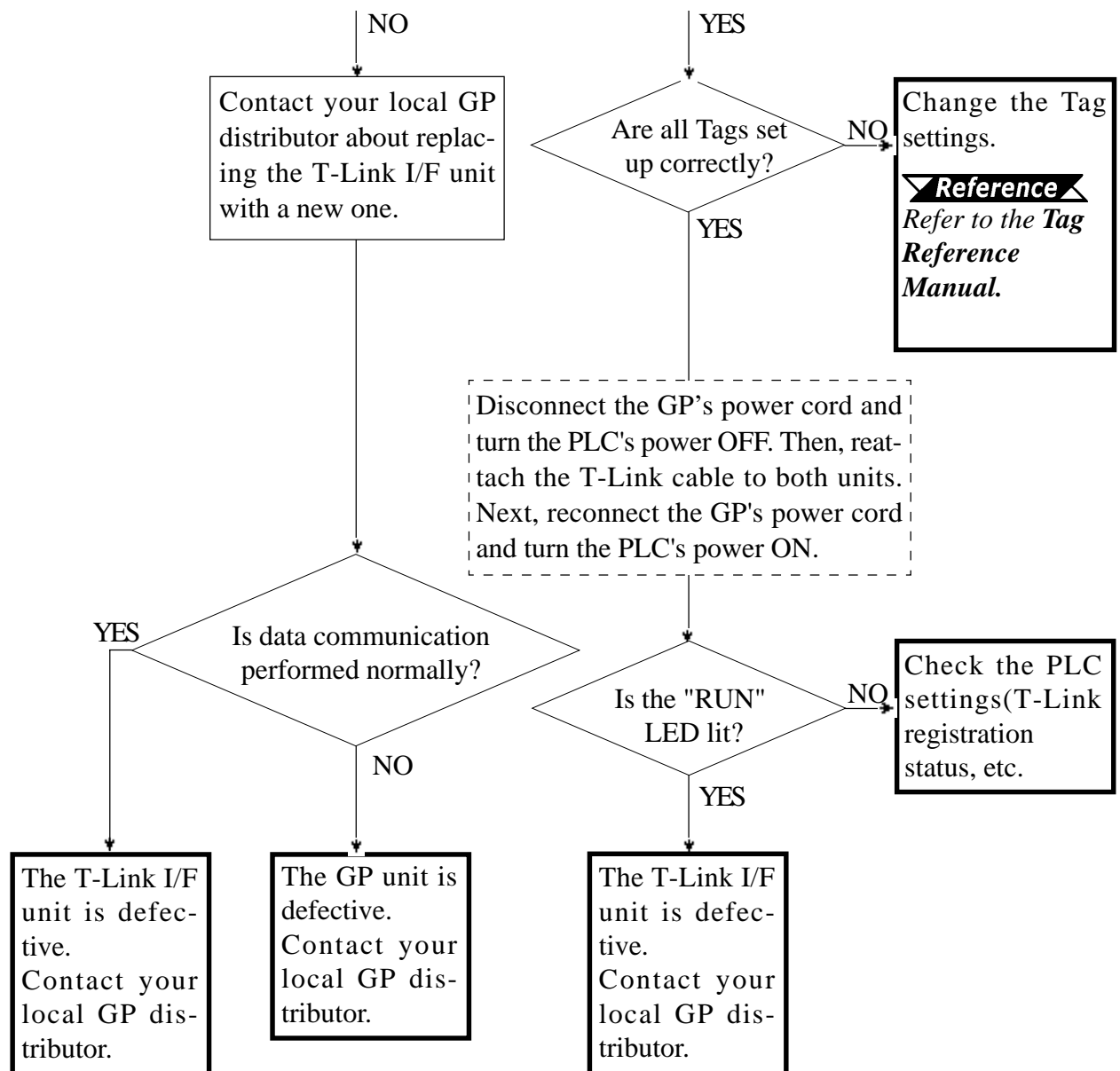

## 5 Touch Panel Does Not Respond

If no response is obtained when pushing the touch panel, follow the flowchart described below to find the cause of trouble and proceed with appropriate process.

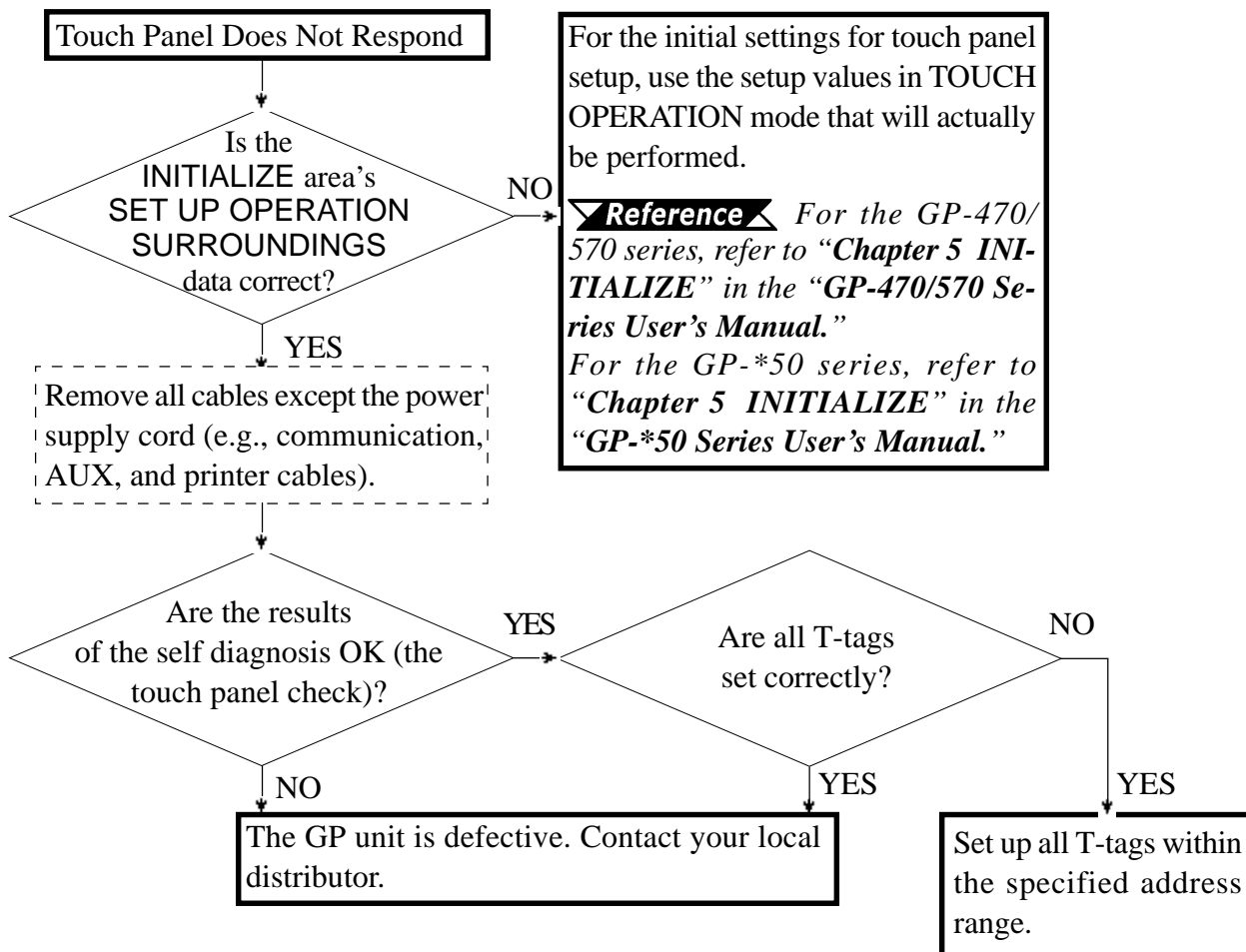



### 5-2 Self-Diagnosis (GP and T-Link)

The GP has a self-diagnosis program that can be used to check if the GP's system and interfaces are functioning correctly. When a problem occurs, use this program to diagnose the problem.

Here, only the T-Link communication's self-diagnosis procedure is explained.

For detailed information about how to call up the self-diagnosis menu and utilize the various self-diagnosis features, refer to your GP's User's Manual.

#### Communication Check

This feature checks the T-Link I/F unit. Use the following procedure to perform self-diagnosis and determine if a T-Link communication abnormality exists.

- 1) Select the GP OFFLINE self-diagnosis menu's "[B] SIO CHECK" feature.
- 2) Reset the T-Link I/F area to begin the checking program.



***DO NOT check the T-Link I/F unit while checking the communication between the PLC and GP. A Fatal Error alarm (ALM 1) or Non-Fatal Error (ALM 2) may occur, which will stop the PLC.***

## 5-3 Error Messages

Error messages that are displayed when errors occur during GP operation are described here. Use these error messages to check the problem conditions and take appropriate countermeasures to solve the problems.

After the problems are solved, turn the power ON/OFF and restart the GP.

### 1 Error Message List

The messages "PLC NOT RESPONDING," "PLC COM. ERROR," and "OBJ. PLC HAS NOT BEEN SETUP" messages are explained in the following pages. An explanation of all other GP messages can be found in your GP User's Manual.

- SYSTEM ERROR
- ILLEGAL ADDRESS IN SCREEN DATA
- UNSUPPORTED TAG IN SCREEN DATA
- PLC NOT CONNECTED (02:FF)
- PLC NOT RESPONDING (02:FE)
- RECEIVE DATA ERROR (02:FD)
- PLC COM. ERROR
- SCREEN MEMORY DATA IS CORRUPT
- OBJ. PLC HAS NOT BEEN SETUP
- CLOCK SETUP ERROR
- SCREEN TRANSFER ERROR



- ***Priorities are given to error messages. When a system error occurs, the message "SYSTEM ERROR" is displayed prior to any other messages. When other types of errors occur, only the message for the most recent error is displayed.***
- ***After an error is corrected, the error message will remain displayed on the GP screen. To correct this, change the screen to another or reset the GP.***
- ***Error messages are displayed on B (Base) screens. When window(s) are opened on the B screen, however, error message(s) may become invisible.***

## 2 Error Message Details

### ■ PLC NOT RESPONDING (02:FE)

This error message is displayed when a time-out occurs while receiving data or there is too much noise in the the communication line (cable).

The possible causes and solutions are described below.

Cause	Solution
The host PLC is turned OFF, or in stop mode.	Turn on the PLC power supply.
The PLC and the GP have been turned on in the wrong order.	First turn on the PLC power supply, then turn on the GP power supply after 2 to 3 seconds.
The communication cable is not connected properly.	Check the wiring of the communication cables, and wire them correctly.

### ■ PLC COM ERROR

This error message is displayed when the address value set for the tag exceeds the range specified by the PLC. Check the error numbers shown here, and try the related solution.

#### PLC COM ERROR ( 02 : x x)

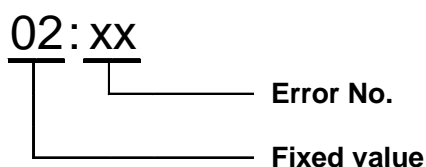

Error Code	Cause	Solution
F5	Completed Flag error. Send Completed Flag or Receive Completed Flag has been designated incorrectly.	Contact your local GP distributor.
F6	Reception interruption error. An inappropriate interrupt request has been sent from the T-link I/F unit.	
F8	T-link I/F section error. The initial Completed Flag does not become "1."	
F9	T-link I/F section RAM error.	
FA	Address range error.	Re-designate the Address within the allowed device range.
51	Addresses which have been designated via tags, where trend graph data has been stored, and which were designated when alarm messages were registered, do not exist in the PLC's internal memory.	Re-designate the addresses within the PLC's existing device range.
Others	Error codes other than the above are the PLC's data transmission status codes. Please contact Fuji Electric for these codes.	

### ■ OBJ. PLC HAS NOT BEEN SETUP

This message is displayed when incorrect data, i.e. other than that used for Fuji Electric's MICREX-F (T-Link), has been transferred to the GP. First, initialize the GP and then retransfer the correct project data from your PC.