

**Digital**  
*Human Machine Interface* ———

**Pro-face**

# GLC2400/2500/2600 Series User Manual

**Digital**  
Digital Electronics Corporation

# Preface

---

Thank you for purchasing the Pro-face Graphic Logic Controller GLC2400T/GLC2500T/GLC2600T (hereby referred to as “GLC” or “GLC unit”).

This controller features a number of improvements over the previous GLC series including enhanced functions and advanced operability. Flex Network communication, Ethernet, CF Card, and Sound output are available for the GLC2000 Series without having to purchase and install an optional expansion unit.

Please read this manual carefully as it explains, step by step, how to use the GLC correctly and safely.

Also, in this manual’s examples, the Mitsubishi MELSEC-AnA Series PLC is used whenever possible, connected in a one-to-one relationship with a GLC.

## <Note>

1. Copying this manual’s contents, either in whole or in part, is prohibited without the express permission of Digital Electronics Corporation, Japan.
2. The information contained in this manual is subject to change without notice.
3. If you should you find any errors or omissions in this document, please contact Digital Electronics Corporation to report your findings.
4. Please be aware that Digital Electronics Corporation shall not be held liable by the user for any damages, losses, or third party claims arising from any uses of this product.

All Company/Manufacturer names used in this manual are the registered trademarks of those companies.

© Copyright 2003, Digital Electronics Corporation

# Table of Contents

Preface .....	1
Table of Contents .....	2
Essential Safety Precautions .....	6
General Safety Precautions .....	12
About GLC2000 Series Models .....	14
Package Contents .....	14
UL/c-UL Application Notes .....	15
CE Marking Notes .....	16
Revision Version .....	17
Documentation Conventions .....	18

## Chapter 1 Introduction

1.1 Prior to Operating the GLC .....	1-1
1.2 System Design .....	1-2
1.3 Accessories .....	1-7
1.4 GLC2000 Series Overview .....	1-11
1.4.1 Ethernet Connectivity .....	1-12
1.4.2 CF Card .....	1-13
1.4.3 Sound Output .....	1-14
1.4.4 Expansion Serial I/F .....	1-14
1.4.5 Flex Network Communication I/F .....	1-15
1.4.6 Printer / Serial Device / Tool Connector Interface .....	1-16
1.4.7 Internal 2-Port Feature .....	1-16
1.4.8 Backlight Burnout Detection Feature .....	1-18

## Chapter 2 Specifications

2.1 General Specifications .....	2-1
2.1.1 Electrical .....	2-1
2.1.2 Environmental .....	2-2
2.1.3 Structural .....	2-2
2.2 Functional Specifications .....	2-3
2.2.1 Display .....	2-3
2.2.2 Memory .....	2-4
2.2.3 Control Memory .....	2-4
2.2.4 Resolutino / Clock .....	2-4
2.2.5 Interfaces .....	2-5

<b>2.3</b>	<b>Interface Specifications .....</b>	<b>2-6</b>
2.3.1	Serial Interfaces .....	2-6
2.3.2	Printer Interface .....	2-8
2.3.3	External Reset Input I/F, Flex Network Communication I/F, and Sound Output I/F .....	2-8
<b>2.4</b>	<b>Part Names and Functions .....</b>	<b>2-9</b>
<b>2.5</b>	<b>Dimensions .....</b>	<b>2-12</b>
2.5.1	GLC2400T External Dimensions .....	2-12
2.5.2	GLC2500T/GLC2600T External Dimensions .....	2-13
2.5.3	Installation Fasteners .....	2-14
2.5.4	Panel Cut Dimensions .....	2-14

<b>Chapter 3</b>	<b>Installation and Wiring</b>
------------------	--------------------------------

<b>3.1</b>	<b>Installation .....</b>	<b>3-1</b>
3.1.1	Installation Procedures .....	3-1
<b>3.2</b>	<b>Wiring Cautions .....</b>	<b>3-6</b>
3.2.1	Connecting the Power Cord .....	3-6
3.2.2	Conneting the Power Supply .....	3-8
3.2.3	Grounding .....	3-10
3.2.4	I/O Signal Line Cautions .....	3-11
3.2.5	Installation Cautins .....	3-11
<b>3.3</b>	<b>Tool Connector .....</b>	<b>3-14</b>
<b>3.4</b>	<b>Ethernet Cable Connector .....</b>	<b>3-14</b>
<b>3.5</b>	<b>CF Card Installation and Removal .....</b>	<b>3-15</b>
3.5.1	CF Card Handling .....	3-17
<b>3.6</b>	<b>Connecting to the Screw Lock Terminal .....</b>	<b>3-18</b>
3.6.1	Cable Preparation .....	3-18
3.6.2	Terminal Connetion .....	3-18
3.6.3	Sound Volume Adjustment .....	3-20

<b>Chapter 4</b>	<b>Data Transfer</b>
------------------	----------------------

<b>4.1</b>	<b>Serial Data Transfer .....</b>	<b>4-1</b>
<b>4.2</b>	<b>Ethernet Data Transfer .....</b>	<b>4-4</b>
4.2.1	Checking the IP Address .....	4-5
<b>4.3</b>	<b>CF Memory Loader Tool .....</b>	<b>4-6</b>
4.3.1	Data Upload and Download .....	4-7

## Chapter 5 OFFLINE Mode

<b>5.1</b>	<b>Entering OFFLINE Mode .....</b>	<b>5-1</b>
5.1.1	After Plugging in the Power Cord .....	5-2
5.1.2	From the Menu Bar .....	5-2
<b>5.2</b>	<b>OFFLINE Mode Main Menu .....</b>	<b>5-3</b>
<b>5.3</b>	<b>INITIALIZATION .....</b>	<b>5-4</b>
<b>5.4</b>	<b>SELF-DIAGNOSIS .....</b>	<b>5-6</b>

## Chapter 6 Initializing the GLC

<b>6.1</b>	<b>Initialization Screen .....</b>	<b>6-1</b>
<b>6.2</b>	<b>Initialization Items .....</b>	<b>6-2</b>
<b>6.3</b>	<b>System Environment Setup .....</b>	<b>6-3</b>
6.3.1	SYSTEM SETUP .....	6-3
6.3.2	SYSTEM AREA SETUP .....	6-4
6.3.3	GLOBAL WINDOWS SETUP .....	6-6
6.3.4	CHARACTER STRING DATA SETUP .....	6-7
<b>6.4</b>	<b>SET UP I/O .....</b>	<b>6-10</b>
6.4.1	SET UP SIO .....	6-10
6.4.2	SET UP PRINTER .....	6-12
6.4.3	SET UP TOUCH PANEL .....	6-15
6.4.4	COMMUNICATION SETUP .....	6-17
6.4.5	SOUND SETTINGS .....	6-17
6.4.6	EXPANSION SERIAL SETUP .....	6-18
6.4.7	EXPANSION SERIAL ENVIRONMENT SETUP .....	6-20
6.4.8	SETUP CAPTURE OPERATION .....	6-21
6.4.9	SET UP DISPLAY DEVICE .....	6-22
6.4.10	FUNCTION SETUP .....	6-22
6.4.11	COMMUNICATION PORT SETUP .....	6-23
<b>6.5</b>	<b>PLC SETUP .....</b>	<b>6-24</b>
6.5.1	SET UP OPERATION SURROUNDINGS (1:1/n:1) .....	6-24
6.5.2	STATION SETUP (n:1) .....	6-25
6.5.3	CUSTOMIZE SETUP (n:1) .....	6-27
6.5.4	ETHERNET SETUP .....	6-29
6.5.5	SYSLOG SETUP .....	6-30
6.5.6	OTHERS SETUP .....	6-31
6.5.7	SELF-DIAGNOSIS .....	6-31
6.5.8	Controller Settings .....	6-32
<b>6.6</b>	<b>INITIALIZE MEMORY .....</b>	<b>6-35</b>
6.6.1	INITIALIZE GLC MEMORY .....	6-35
6.6.2	INITIALIZE CF CARD .....	6-36
6.6.3	CSV DATA INDEX .....	6-36

6.7	SET UP TIME .....	6-37
6.8	SET UP SCREEN .....	6-38

**Chapter 7 RUN Mode and Errors**

7.1	<b>RUN Mode</b> .....	7-1
7.1.1	After Connecting the Power Cord .....	7-1
7.1.2	Via OFFLINE Mode .....	7-2
7.2	<b>SELF-DIAGNOSIS</b> .....	7-3
7.2.1	SELF-DIAGNOSIS ITEM LIST .....	7-3
7.2.2	SELF-DIAGNOSIS - Details .....	7-4
7.2.3	CONTROLLER SELF-DIAGNOSIS .....	7-8
7.3	<b>Troubleshooting</b> .....	7-9
7.3.1	Possible Types of Trouble .....	7-9
7.3.2	No Display .....	7-10
7.3.3	No GLC/Host Communication .....	7-13
7.3.4	Touch Panel Does Not Respond .....	7-15
7.3.5	Cannot Execute Logic Program .....	7-16
7.3.6	Buzzer Sounds when GLC power is turned ON .....	7-17
7.3.7	Clock Settings Cannot be Entered .....	7-18
7.3.8	Error Screens .....	7-18
7.4	<b>Error Messages</b> .....	7-19
7.4.1	Error Message List .....	7-19
7.5	<b>Error Message Details</b> .....	7-21
7.5.1	System Errors .....	7-21
7.5.2	Illegal Address Screen Data .....	7-23
7.5.3	PLC COM. Error .....	7-24
7.5.4	Clock Set Up Error .....	7-25
7.5.5	Screen Tag Limit Exceeded (max. 384) .....	7-25
7.5.6	OBJ. PLC Has Not Been Set Up .....	7-25
7.5.7	D-Script and Global D-Script Errors .....	7-26
7.5.8	Extended SIO Script Error .....	7-27
7.5.9	Serial I/F Change Error .....	7-28

**Chapter 8 Maintenance**

8.1	<b>Regular Cleaning</b> .....	8-1
8.1.1	Cleaning the Display .....	8-1
8.1.2	Installation Gasket Check / Replacement .....	8-1
8.2	<b>Periodic Check Points</b> .....	8-2
8.3	<b>Replacing the Backlight</b> .....	8-3
8.3.1	Replacing CA3-BLU12-01 .....	8-5

**Index**

# Essential Safety Precautions

---

This manual includes procedures that must be followed to operate the GLC correctly and safely. Be sure to read this manual and any related materials thoroughly to understand the correct operation and functions of the GLC unit.

## ■ Safety Symbols

Please pay attention to the following safety symbols and their meanings:



Indicates situations that will definitely result in severe bodily injury, death, or major machine damage if the instructions are not followed.



Indicates situations that may result in severe bodily injury, death, or major machine damage if the instructions are not followed.



Indicates situations that may result in minor bodily injury or damage to the machinery if the instructions are not followed.

## **DANGERS**

### When Designing your GLC System:

- **Be sure to design your GLC control system so that, in the event of a main power supply failure or a GLC accident, the user system's overall safety integrity will be maintained. If this is not done, incorrect output signals or a GLC malfunction may cause an accident.**
  - (1) **Interlock and other circuits designed to interrupt or oppose normal machine movement (such as Emergency Stop, General Protection, and forward and reverse rotation), as well as those designed to prevent machine damage (such as upper, lower, and traverse movement limit positioning) should all be designed to be located outside of the GLC.**

 **DANGERS**

**(2) When the GLC generates a “Watchdog Timer Error,” GLC operation will halt. Also, when Errors occur in Input/Output control areas that the GLC cannot detect, unexpected movement may occur in those areas. Therefore, and to prevent unsafe machine movement, a “Failsafe Circuit” should be created which is completely external to the GLC.**

**(3) If a problem arises with an external unit’s relay or transistor, causing an output (coil) to remain either ON or OFF, a major accident can occur. To prevent this, be sure to set up external watchdog circuits that will monitor vital output signals.**

- **Design a circuit that will supply power to the GLC unit’s I/O before starting up the GLC. If the GLC unit’s internal program enters RUN mode prior to the I/O unit’s load control power turning ON, an incorrect output (signal) or malfunction could cause an accident.**
- **Design a user program that ensures the safety of the user’s system, in the event of a GLC display or control error, or either a data transmission error or power failure between the GLC and a connected unit. These types of problems can lead to an incorrect output (signal) or malfunction, resulting in an accident.**
- **Do NOT make switches using the switches on the touch panels which may cause operator injury and machine damage. An output may remain either ON or OFF and a major accident can occur. To prevent this, set up circuits such as limiters that will monitor vital output signals. Design switches for important operations to be performed by separate devices. An incorrect output or malfunction can occur and thereby cause an accident.**
- **Do NOT use GLC touch panel switches to perform operator safety-related or important accident-prevention operations. These operations should be performed by separate hardware switches to prevent operator injury and machine damage.**





## DANGERS

- Design your system so that equipment will not malfunction due to a communication fault between the GLC and its host controller. This is to prevent any possibility of bodily injury or material damage.
- Do NOT use the GLC as a warning device for critical warning alarms that can cause serious operator injury, machine damage, or production stoppage. Use stand-alone hardware and/or mechanical interlocks to design alarm indicators and their control/activator units.
- The GLC is not appropriate for use with aircraft control devices, medical life-support equipment, central trunk data transmission (communication) devices, or nuclear power control devices, due to their inherent requirements of extremely high levels of safety and reliability.
- When using the GLC with transportation vehicles (trains, cars, and ships), disaster and crime prevention devices, various types of safety equipment, and medical devices that are not life-support related, use redundant and/or failsafe system designs to ensure proper reliability and safety.



## WARNINGS

- Unlike the GLC unit's "Standby Mode," after the GLC unit's backlight burns out, the touch panel is still active. If the operator fails to notice that the backlight is burned out and touches the panel, a potentially dangerous machine misoperation can occur. Your backlight is burned out if:
  - your GLC is not set to "Standby Mode" and the screen has gone blank
  - your GLC is set to "Standby Mode," but touching the screen does not cause the display to reappearTo prevent accidental machine misoperation, Pro-face recommends that you use the GLC unit's "USE TOUCH PANEL AFTER BACKLIGHT BURNOUT" feature, to automatically detect a burnout and disable the touch screen.



## WARNINGS

### Installation Warnings:

- **High voltage runs through the GLC. To prevent an electrical shock, do NOT disassemble the GLC for any reason other than to replace the backlight.**
- **Do NOT modify the GLC unit. Doing so may cause a fire or an electrical shock.**
- **Do NOT use the GLC in an environment where flammable gases are present. Operating the GLC under these conditions may cause an explosion.**

### Wiring Warnings:

- **To prevent electrical shock or equipment damage, unplug the GLC unit's power cord from the power supply prior to installing or wiring the GLC.**
- **After completing any GLC wiring work, be sure the terminal block's protective plastic cover is reattached. If this cover is not reattached, an electrical shock could easily occur.**
- **Do NOT use power levels with the GLC that are higher or lower than the GLC unit's specified power range. Doing so may cause a fire, electrical shock, or GLC damage.**

### Operation and Maintenance Warnings:

- **NEVER touch a live power terminal. Doing so could cause an electrical shock or a machine malfunction.**
- **To prevent an electrical shock, unplug the GLC unit's power cord before either cleaning the GLC or attaching/detaching the power terminal attachment screws.**
- **When replacing the GLC unit's backlight, be sure to unplug the unit's power cord to prevent an electrical shock, and wear safety gloves to prevent burns.**



## WARNINGS

- The GLC uses a lithium battery to back up its internal clock and to control memory data. If the battery is incorrectly replaced (reversed positive [+] and negative [-] ends), the battery may explode. Therefore, Pro-face recommends that you contact your local GLC distributor for instructions before replacing or changing the battery.



## CAUTIONS

### Wiring Layout Cautions:

- To prevent a GLC unit malfunction due to excessive noise, isolate all GLC input/output signal lines from all power wiring or power cables via a separate wiring duct.

### Installation Cautions:

- To reduce the risk of incorrect input or output signals, be sure that any data cables attached to the GLC unit's connector make full contact with the connector pins.

### General Wiring Cautions:

- To prevent electrical shocks or malfunctions, be sure the GLC unit's FG (earth) wire is grounded as follows:
  - (1) maximum grounding resistance: 100  $\Omega$
  - (2) minimum grounding wire diameter: 2 mm<sup>2</sup>
- The cables connected to the GLC should be secured by cable clamps to prevent weight or tension of the cables added to the connectors or terminals.
- The GLC unit's wiring should be checked to confirm that both the operating voltage and wiring terminal locations are correct. If either the voltage or the wiring terminal location is incorrect, it can cause a fire or accident.
- Be sure to secure all wiring terminal screws with the designated torque. Screws and terminals that become loose can cause a short circuit, fire, or accident.



## CAUTIONS

- Be sure that metal filings or wiring remnants do not fall inside the GLC, since they can cause a fire, accident, or malfunction.

### GLC Operation and Maintenance Cautions:

- Be sure to read the GLC unit's manual and online help information carefully before performing program changes, entering forced output, or using the RUN, STOP, or PAUSE commands while the GLC is operating. Mistakes made when using these items can cause machine accidents or damage.
- Be sure the electricity is turned OFF before attaching or detaching an I/O unit. If the electricity is ON when an I/O unit is attached or detached, damage or malfunction to the I/O unit may occur.
- The liquid crystal panel contains a powerful irritant. If, for any reason, the panel is damaged and this liquid enters your eyes, flush your eyes for 15 minutes with running water and contact a physician immediately.
- Prior to inserting or removing a CF Card, and to prevent damage to or loss of the CF Card's internal data, turn the GLC unit's CF Card ACCESS switch OFF, and make sure that the ACCESS lamp is not lit.
- While a CF Card is being accessed, NEVER
  - turn OFF the GLC
  - reset the GLC
  - insert a CF Card
  - remove a CF Card

Prior to performing these operations, create and use a special GLC application screen that will prevent access to the CF Card.

### GLC Unit Disposal Cautions:

- The GLC unit should be disposed of in a manner appropriate to, and in accordance with, the user country's industrial machinery disposal standards.

# General Safety Precautions

---

- Do NOT strike the touch panel with a hard or pointed object, or press on the touch panel with too much force, since it may damage the touch panel or the display.



- Do NOT install the GLC where the ambient temperature can exceed the allowed range. Doing so may cause the GLC to malfunction or shorten its operation life.

- Do NOT restrict or limit the GLC unit's naturally-occurring, rear-face ventilation, and do NOT store or use the GLC in overheated areas.

- Do NOT store or use the GLC unit in areas where large, sudden temperature changes can occur. These changes can cause condensation to form inside the unit, which can cause possible unit malfunctions.

- Do NOT allow water, liquids, metals, or charged particles to enter inside the GLC unit's outer casing, since they can cause either a GLC malfunction or an electrical shock. The allowable pollution degree is 2.

- Do NOT store or use the GLC in direct sunlight, or in excessively dusty or dirty environments.

- Do NOT store or use the GLC in an environment where shaking or excessive vibration can occur.



- Do NOT store or use the GLC where chemicals (such as organic solvents and acids) can evaporate, or in environments where chemicals and acids are present in the air.

Corrosive chemicals: acids, alkalines, liquids containing salt

Flammable chemicals: organic solvents

- Do NOT use paint thinner or organic solvents to clean the GLC.

- Do NOT store or operate the LCD (Liquid Crystal Display) in areas that receive direct sunlight, since the sun's ultraviolet (UV) rays may cause the quality of the LCD to deteriorate.

- Storing this unit in areas at temperatures that are lower than is recommended in this manual's specifications may cause the LCD panel's liquid to congeal, which may damage the panel. Conversely, if the storage area's temperature becomes higher than the allowed level, the LCD panel's liquid will become isotropic, causing irreversible damage to the LCD. Therefore, be sure to store the panel only in areas where temperatures are within the ranges specified in this manual.

- Due to the possibility of unexpected accidents, be sure to back up the GLC unit's screen data/logic program regularly.

## ■ About the GLC Unit's Display Panel

- The data that is currently displayed on the GLC unit's screen, the screen's brightness, and the GLC unit's voltage<sup>1</sup> each affect the screen's intensity of *Contouring* — wavelike pattern that is created when some parts of the screen are brighter than others.
- The minute, dark and light grid-points on the display panel's surface are part of the GLC unit's design and are not defects.
- Extended shadows, or “crosstalk,” may appear on the sides of screen images. This is normal for an LCD panel.
- Sometimes the display area may look as if the display colors have changed. This is a common attribute of LCDs and is not a defect.
- Displaying a single image for long periods of time can cause an afterimage to remain when the screen display is changed.

To prevent this effect:

Use the GLC unit's “Standby Mode,” which automatically turns the screen OFF when no input is entered within a specified period of time.

### *Section 6.3.1 – “System Setup”*

- Write “FFFFh” to the System Data Area's “Screen Display Off” address<sup>2</sup> to turn the screen display OFF when the following actions are not performed within the user-specified period of time.
  - Change Screen
  - Touch Screen
  - Alarm Display

**Do NOT display any single screen for a long period of time. Try to change the screen display periodically.**

- 
1. *The backlight's brightness may vary or its lighting may be delayed if the voltage provided is low — even if still within the range of rated voltage listed in the specifications. When the voltage is high, the backlight's lifetime may be shortened. As a rule, voltage should be within five percent (5%) of rated voltage.*
  2. *The following addresses assume all System Data Area settings are entered. If they are not all entered, the correct word address may be different, since the following addresses are relative, not fixed, addresses.*

*With the Direct Access Method — use System Data Area word address +9*

*With the Memory Link Method — use System Data Area word address +12*

***GP-PRO/PBIII for Windows Device/PLC Connection Manual***

---

# About GLC2000 Series Models

The GLC2000 Series in this manual refers to the following GLC model numbers:

Series Name	Model Name	Model Number	Comments	GLC Type with Screen Creation Software
GLC2000 Series	GLC2400T	GLC2400-TC41-24V	UL/c-UL Approved*1 CE Marked	GLC2400
	GLC2500T	GLC2500-TC41-200V		GLC2500
		GLC2500-TC41-24V		
	GLC2600T	GLC2600-TC41-200V		GLC2600
		GLC2600-TC41-24V		

\*1 UL1604 for UL hazardous locations ends on July 31, 2012. As a result, for models produced from August 1, 2012 onward, UL1604 will not apply.

Please refer to the Pro-face home page for more details.

<http://www.pro-face.com/worldwide/safety/ul.html>

## Package Contents

Please verify that the GLC unit's packing box contains all the items listed below.

■ **GLC Unit (1)**

GLC2400-TC41-24V  
 GLC2500-TC41-200V GLC2500-TC41-24V  
 GLC2600-TC41-200V GLC2600-TC41-24V

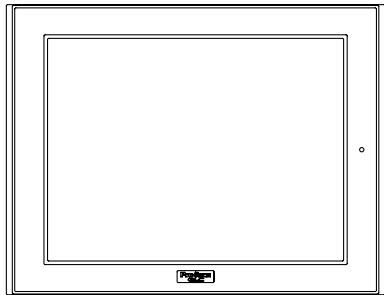

■ **Installation Guide (1)\*1**

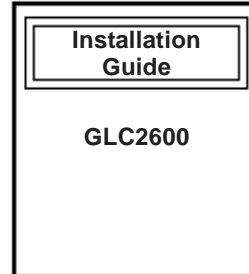

■ **Installation Fasteners (4/set)**

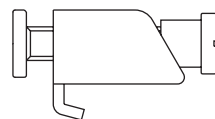

■ **Installation Gasket**



Special care and attention have been given to the packaging of this GLC unit. However, if any of the items are damaged or missing, contact your local GLC distributor immediately for prompt service.

1. This GLC2000 Series User Manual is sold separately.

# UL/c-UL Application Notes

The GLC2500-TC41-200V, GLC2600-TC41-200V are UL/c-UL recognized components. (UL File No.E171486 or E231702)

The GLC2400-TC41-24V, GLC2600-TC41-24V are UL/c-UL listed products. (UL File No.E182139)

Model	UL registered format	Standards						
		A	B	C	D	E	F	G
GLC2400-TC41-24V	2980025	○		○	○			
GLC2500-TC41-200V	3280036-02		○				○	
GLC2500-TC41-24V	3280036-03							
GLC2600-TC41-200V	3280036-01		○	○			○	○
GLC2600-TC41-24V	3280021-01	○		○		○		

## These products conform to the following standards:

**A) ■UL 508** Industrial Control Equipment

**B) ■UL 60950**

Safety Standard for Information Technology Equipment (3rd Edition, issued December 1, 2001)

**C) ■UL 1604** Electrical Equipment for Use in Class I and II Division 2 and Class III Hazardous(Classified) locations

**D) ■CAN/CSA-C22.2, No.142 and 213-M1987 (c-UL Approval)**

Safety Standard for Information Technology and Electrical Business Equipment

**E) ■CAN/CSA-C22.2, No.1010-1 (c-UL Approval)**

Safety Requirements for Electrical Equipment for Measurement, Control and Laboratory use

**F) ■CAN/CSA-C22.2, No.60950-00 (c-UL Approval)**

Safety Standard for Information Technology Equipment (3rd Edition, issued December 1, 2001)

**G) ■CAN/CSA-C22.2, No.213-M1987 (c-UL Approval)**

Safety Standard for Information Technology and Electrical Business Equipment

## <Cautions>

Be aware of the following items when building the GLC into an end-use product:

- The GLC unit's rear face is not approved as an enclosure. When building the GLC unit into an end-use product, be sure to use an enclosure that satisfies standards as the end-use product's overall enclosure.
- The GLC unit must be used indoors only.
- Install and operate the GLC with its front panel facing outwards.
- If the GLC is mounted so as to cool itself naturally, be sure to install it in a vertical panel. Also, insure that the GLC is mounted at least 100 mm away from any other adjacent structures or machine parts. If these conditions are not met, the heat generated by the GLC unit's internal components may cause it to fail to meet UL standards.
- When applying for approval as a component, i.e. building the GLC into an end-use product, UL evaluation and approval must be obtained for the combination of the GLC and the end-use product.



## Preface

### **UL1604/CSA-C22.2, No.213 Conditions of Acceptability and Handling Cautions:**

1. Power, input and output (I/O) wiring must be in accordance with Class I, Division 2 wiring methods - Article 501- 4(b) of the National Electrical Code, NFPA 70 within the United States, and in accordance with Section 18-152 of the Canadian Electrical Code for units installed within Canada.
2. Suitable for use in Class I, Division 2, Groups A, B, C and D Hazardous Locations.
3. WARNING: Explosion hazard - substitution of components may impair suitability for Class I, Division 2.
4. WARNING: Explosion hazard - when in hazardous locations, turn power OFF before replacing or wiring modules.
5. WARNING: Explosion hazard - do not disconnect equipment unless power has been switched off or the area is known to be nonhazardous.
6. WARNING: Explosion hazard - do not connect/ disconnect equipment unless area is known to be nonhazardous. Port is for system set up and diagnostics.

## **CE Marking Notes**

---

The GLC2500-TC41-200V and GLC2600-TC41-200V are CE marked products that conform to EMC directives and the Low-voltage directive.

The GLC2400-TC41-24V, GLC2500-TC41-24V, and GLC2600-TC41-24V are CE marked products that conform to EMC directives.

For the detailed information on CE Marked, be downloaded and refer the Declaration of Conformity from Pro-face Home Page.

Home Page URL

<http://www.pro-face.com/>

# Revision Version

The revision code can be easily found using the GLC unit’s rear face identification label or revision sticker. In the area titled “REV”, the code is indicated by asterisks (\*) or marked with a marker pen.

## ■ How to Read the Code

In the example below, asterisks (\*) are placed at positions “D”, “1”, and “2”, which indicates the revision version as “D-2”.

**Identification Label**

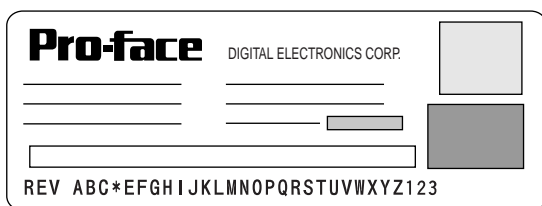

**Revision Sticker**





## ■ Classifying the Revision

Revision Types	Meaning
“Rev.* - None, 1”	The revision code is not used, or is “1”.
“Rev.* - 2 or higher”	The revision code is 2 or higher.

# Documentation Conventions

---

The list below describes the documentation conventions used in this manual.

Symbol	Meaning
	Indicates important information or procedures that must be followed for correct and risk-free software/device operation.
<b>Pro-Control Editor</b>	Software used to create, transfer, and monitor a GLC logic program.
<b>GLC</b>	Indicates the GLC2400T , GLC2500T and GLC2600T units
<b>C-Package</b>	Indicates the combined software package of GP-PRO/PBIII for Windows and Pro-Control Editor.
<b>GP Screen Editor</b>	GP-PRO/PB III for Windows screen editor software <sup>*1 *2</sup>
<b>Logic Program</b>	Ladder program created with the Pro-Control Editor <sup>*1 *3</sup>
	Provides useful or important supplemental information.
	Cross-references to useful or important supplemental information.
<b>PLC</b>	Abbreviation for Programmable Logic Controller.

1. *A separate add-on software is required for a GLC2600T unit. Please contact your local GLC distributor for details.*
2. *For GLC2400/2600 Series Units : GP-PRO/PB III Ver.6.10 or higher is required.  
For GLC2500 Series Units : GP-PRO/PB III Ver.7.00 or higher is required.*
3. *For GLC2400/2600 Series Units : Pro-Control Editor Ver.4.10 or higher is required.  
For GLC2500 Series Units : Pro-Control Editor Ver.5.00 or higher is required.*

# Chapter

# 1 Introduction

1. Prior to Operating the GLC
2. System Design
3. Accessories
4. GLC2000 Series Overview

## 1.1 Prior to Operating the GLC

---

Use the following steps to create projects for the GLC unit.

- 1. Preparation** – Before using the GLC, make sure that you have all the required hardware and have read all specification, wiring, and installation information.  
**Reference** *Chapter 2 – “Specifications” and Chapter 3 – “Installation and Wiring”*
- 2. Screen Design** – Create a sample screen and design a Tag layout with the Screen layout sheets and Tag lists provided in the Editor software.
- 3. Install Screen Editor Software** – Install Screen Editor in your PC.  
**Reference** *GP-PRO/PB III for Windows Operation Manual (included with screen creation software)*
- 4. Install Logic Program Development Software** – Install Pro-Control Editor in your PC.  
**Reference** *Pro-Control Editor Operation Manual (included with Pro-Control Editor)*
- 5. Develop Logic Program** – Develop a logic program using Pro-Control Editor and designate the operation mode.  
**Reference** *Pro-Control Editor Operation Manual (included with Pro-Control Editor)*
- 6. Import Symbols, Create and Set up Screens, and Transfer Display Data** – Import symbols using GP-PRO/PB III for Windows, create the screens for those symbols, and then transfer them to the GLC.  
**Reference** *GP-PRO/PB III for Windows Operation Manual (included with screen creation software)*
- 7. Transfer/Monitor Logic Program** – Transfer your logic program to the GLC using Pro-Control Editor, then use the monitor feature of Pro-Control Editor to check the transferred program’s operation.  
**Reference** *Pro-Control Editor Operation Manual (included with Pro-Control Editor)*
- 8. Initial Set Up** – Enter your GLC unit’s Initial Settings, if necessary.  
**Reference** *GLC User Manual (sold separately), GP-PRO/PB III for Windows Device/PLC Connection Manual (included with screen creation software)*
- 9. Operation** – Connect the GLC to your peripheral devices such as temperature controllers or inverters and begin operation.  
**Reference** *GP-PRO/PB III for Windows Device/PLC Connection Manual (included with screen creation software), and User Manual (for each expansion unit).*

## 1.2 System Design

The following diagram represents the main selection of devices connectable to the GLC.

### ■ GLC RUN Mode Peripherals

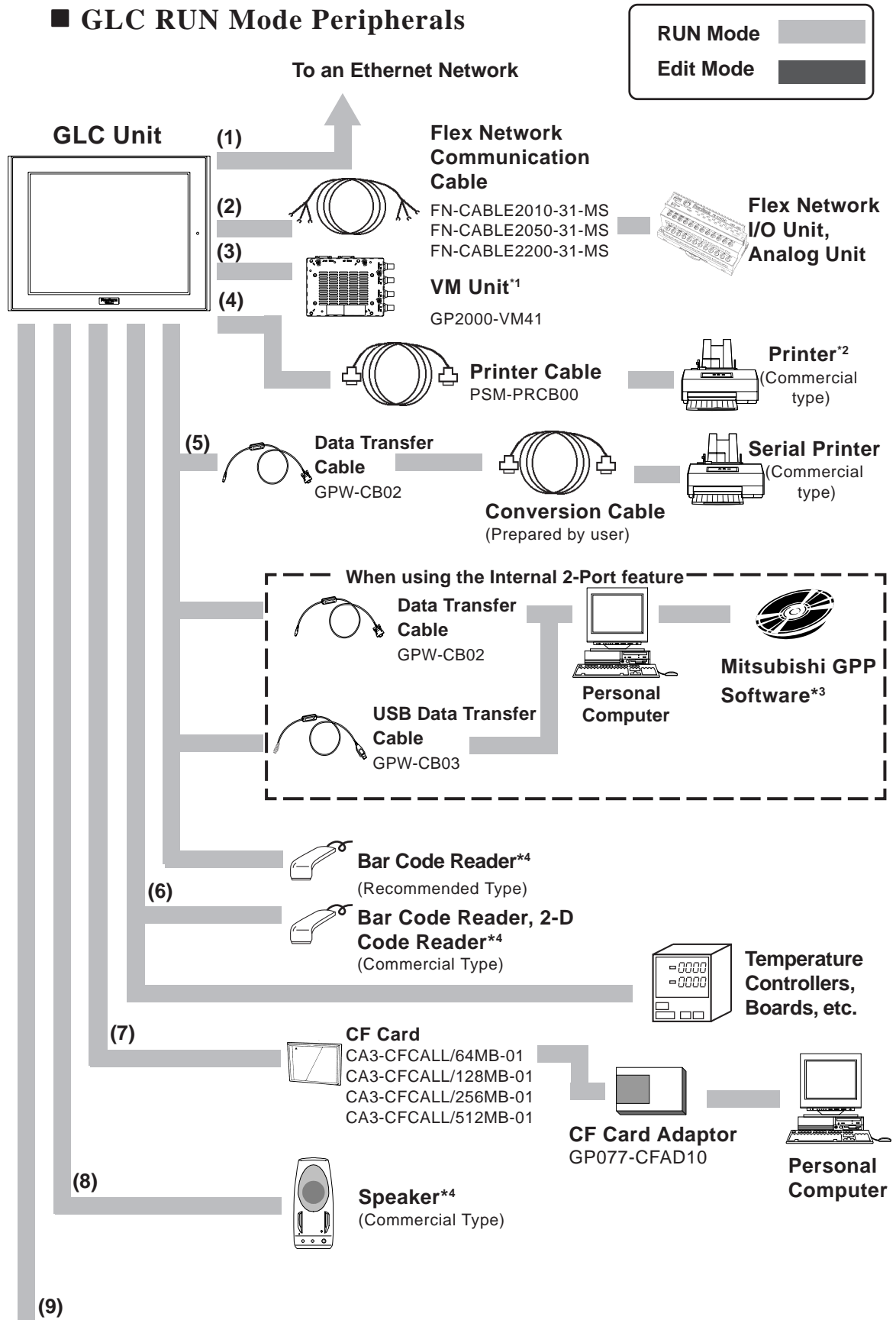

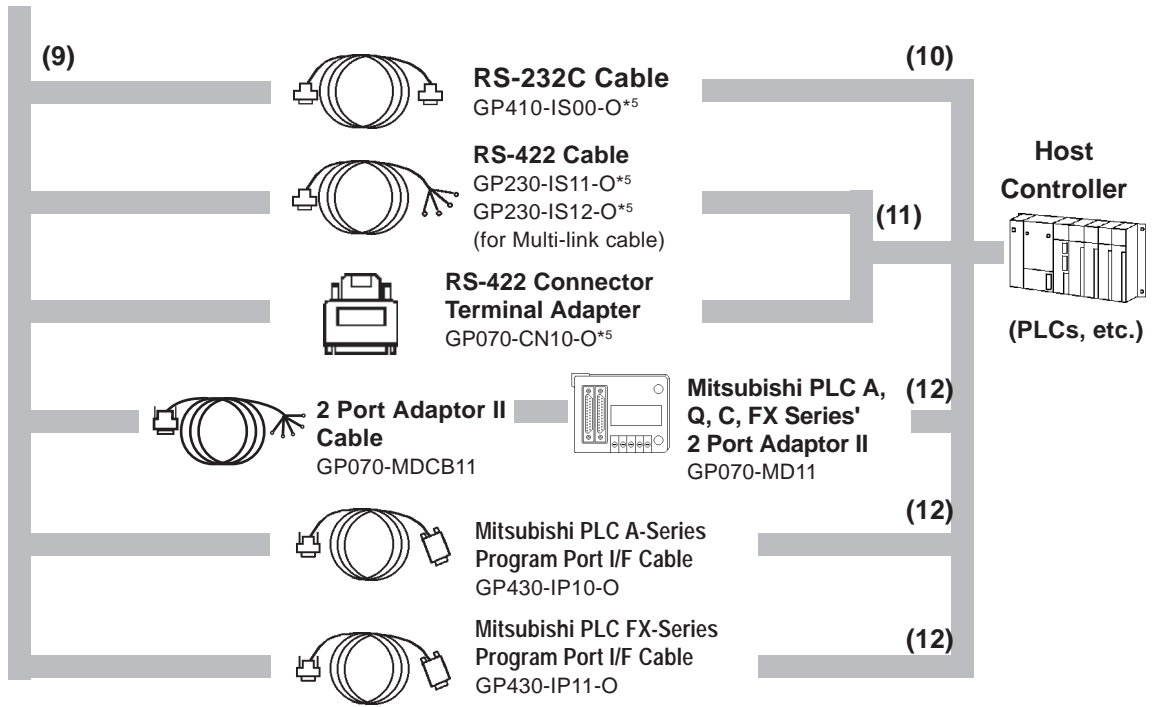

# Chapter 1 – Introduction

## ■ GLC Edit Mode Peripherals

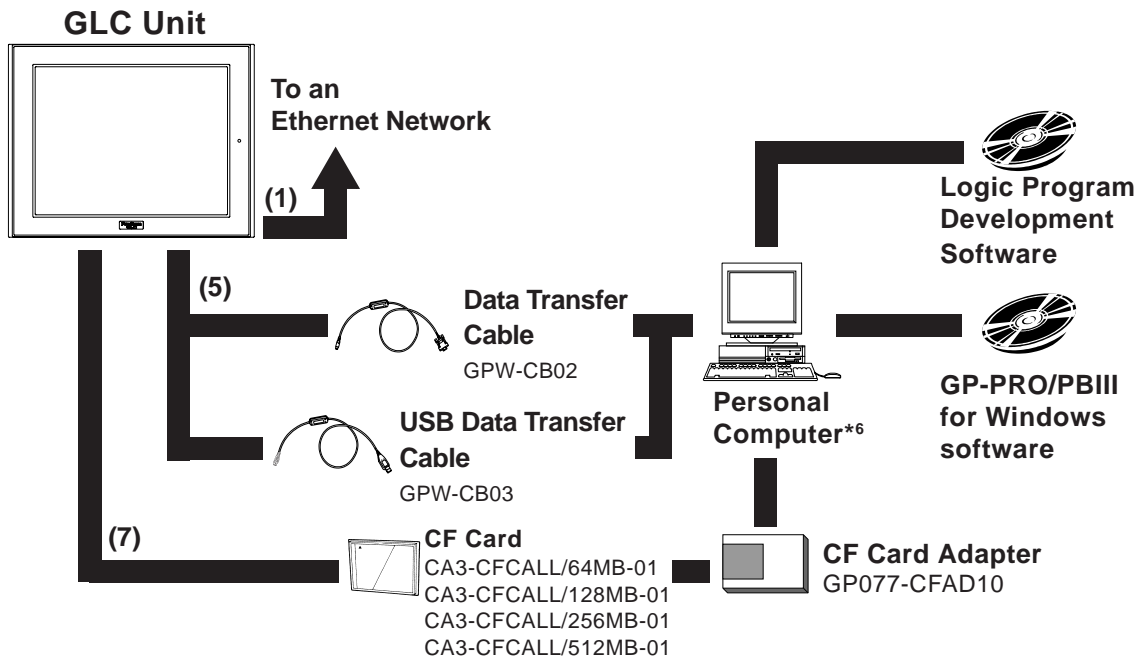

### GLC Interfaces

- (1) Ethernet
- (2) Flex Network Communication Interface
- (3) Expansion Unit Interface 2
- (4) Printer
- (5) Tool Connector
- (6) Expansion Serial Interface
- (7) CF Card Slot

### (8) Sound (AUX) Interface

### (9) Serial Cable Serial Interface

### PLC Interfaces

- (10) RS-232C Port
- (11) RS-422 Port
- (12) Programming Console Port

1. Cannot be used with a GLC2400T unit.
2. Compatible with NECPC-PR201/PL, EPSON ESC/P24-J84(C), HP Laser Jet PCL 4 command printers, EPSON PM/Stylus (6-color ink), EPSON Stylus (4-color ink) printer or their equivalent that are designed for MS-DOS. Printers designed solely for Windows may not be used. Certain printers containing both Windows and DOS drivers may be used. For details, please contact your printer's manufacturer or sales outlet.
3. **Reference** For information about compatible PLC types and software, please refer to the **GP-PRO/PBIII for Windows Device/PLC Connection Manual** (included with the screen creation software)
4. For information about recommended units, please see the next page.
5. Certain types and models of PLCs cannot be connected.  
**Reference** **GP-PRO/PBIII for Windows Device/PLC Connection Manual** (included with the screen creation software)
6. For the full range of compatible PCs, refer to the following manual.  
**Reference** **GP-PRO/PBIII for Windows Operation Manual** (included with the screen creation software)

## ■ Recommended Units

The following tables list I/O devices that have been confirmed to be compatible with the GLC. If you connect a device that is not listed below, be sure to confirm that the unit functions correctly using the actual unit.



---

**Recommended units are subject to additions/changes without notice.**

---

### ◆ Bar Code Readers (Connected to Tool Connector)

Manufacturer	Model	Type	Description
Aimex Corporation	BR-331 PC2	Pen	
OPT Electronics	OPT-1125-RSK-98 Set	Touch Scanner (Read Width: 60mm)	
	OPT-5125-RSK-98 Set	Touch Scanner (Read Width: 80mm)	
	OPL-6735-RSK-98 Set	Laser Scanner	
Tohken	TCD-5510M	Touch Scanner (Read Width: 65mm)	
	TCD-5510L	Touch Scanner (Read Width: 82mm)	
	TCD-5510W	Touch Scanner (Read Width: 105mm)	
NEC Infrontia	BCK5435-STA	Touch Scanner (Read Width: 56mm) <sup>*1*2</sup>	Includes Y cable for connection cable
	BCK5535-STA	Touch Scanner (Read Width: 85mm) <sup>*1*2</sup>	Includes Y cable for connection cable

*\*1 Be sure to use the Y cable included with the unit and connect it between GLC unit and a bar code reader. Data cannot be read correctly, if a non-"Y" cable is used, or if the bar code reader is connected directly to the GLC unit.*

*\*2 The following settings must be entered prior to using the bar code reader with a GLC unit.*

*1) Set the CAPS.*

*2) Add the Carriage Return (CR) in the Postamble's settings.*

*For the details about these settings, please refer to the Installation Guide included with the bar cord unit.*



## Chapter 1 – Introduction

### ◆ Bar Code Readers (Connected to Expansion Serial Interface)\*1

Manufacturer	Model No.	Type	Power Supply
Aimex Corporation	BR-730RS	Pen	Battery powered
	BR-530RS	Pen	Requires separately-sold BB-60 for power.
	BW-665RS	Touch Scanner (Read Width: 65mm)	
OPT Electronics	OPT-1125-RS232C(D02)	Touch Scanner (Read Width: 60mm)	Requires separately-sold DC5300T for power.
	OPT-5125-RS232C(D01)	Touch Scanner (Read Width: 80mm)	
Symbol Technologies, Inc.,	LS4004	Laser Scanner	Includes power supply.
	LS4004i	Laser Scanner	Includes power supply.
	LS6004	Laser Scanner	Includes power supply.
	LSH3502AHV	Laser Scanner	Includes power supply.
Keyence Co.	BL-80R	Touch Scanner (Read Width: 105mm)	Includes power supply.
Denso Co.	HC36TR	Touch Scanner (Read Width: 61mm)	For power: P-200 unit; for connector cable: KRS-423-XF1K. Sold separately (Sanwa Supply)
	HC61TR	Touch Scanner (Read Width: 61mm)	

1. Be sure to confirm that the Expansion Serial Interface's settings match those of the connected device.

▼ **Reference** ▲ 6.4.6 – “Expansion Serial Communication Setup”

### ◆ 2-D Code Reader (Connected to Expansion Serial Interface)\*1

Manufacturer	Model No.	Power Supply
Tohken	THIR-3000	ESA-1220A (Sold separately)
	THIR-3000H	
Denso	QS20H	Supplied with the main unit
	QS20H-I	

1. Be sure to confirm that the Expansion Serial Interface's settings match those of the connected device.

▼ **Reference** ▲ 6.4.6 – “Expansion Serial Communication Setup”

### ◆ Speaker

Models to be connected to LINE OUT require a separate amplifier.

Manufacturer	Model No.	Connection Port
Arrow Electronics	NS-38	SP OUT, GND
	NS-105	

## 1.3 Accessories

All optional equipment listed here is produced by Digital Electronics Corporation.

### ■ Available Software

Product Name	Model No.	Description
GP-PRO/PB III C-Package 03	GP-PRO-CNT01W-P03	Used to create screen and logic program data on your PC for the GLC unit.

### ■ Tool Connector

Product Name	Model No.	Description
Data Transfer Cable	GPW-CB02	Connects the GLC to a personal computer. Transfers screen data and user programs.
USB Data Transfer Cable	GPW-CB03	

### ■ Serial Interfaces

Product Name	Model No.	Description
RS-232C Cable <sup>*1</sup>	GP410-IS00-O	Interface cables between the host (PLC) and the GLC.
RS-422 Cables <sup>*1</sup>	GP230-IS11-O	
	GP230-IS12-O (for multi-link)	
RS-422 Terminal Block Adapter <sup>*1</sup>	GP070-CN10-O	Conversion adapter to convert serial data to RS-422 format.
Mitsubishi A, QnA, FX Series 2 Port Adapter II	GP070-MD11	Interface unit that allows use of both GLC and Mitsubishi A, Q, C and FX series equipment in the same location.
2 Port Adapter II Cable	GP070-MDCB11	Connects the GLC to 2 Port Adapter II.
Mitsubishi A Series Programming Port I/F Cable	GP430-IP10-O	Connects directly to Mitsubishi's PLC I/F Programming Console. Simultaneous use of program console, however, is not possible.
Mitsubishi FX Series Programming Port I/F Cable	GP430-IP11-O	

1. **Reference** For details about the range of connectable PLCs, refer to the **GP-PRO/PBIII for Windows Device/PLC Connection Manual** (included with screen creation software).

### ■ Printer Interface Cable

Product Name	Model No.	Description
Printer Cable	PSM-PRCB00	Connects the GLC and a commercial type printer.

# Chapter 1 – Introduction

## ■ I/O Units

Product Name	Model No.	Description
Flex Network 16-Point Input Sink Source Type I/O Unit	FN-X16TS41	16-point sink/source shared I/O Unit. DC24V input signal can be connected.
Flex Network 32-Point Input Sink Source Type I/O Unit	FN-X32TS41	32-point sink-source shared I/O Unit. DC24V input signal can be connected.
Flex Network 16-Point Output Sink Type I/O Unit	FN-Y16SK41	16-point output sink I/O Unit.
Flex Network 16-Point Output Source Type I/O Unit	FN-Y16SC41	16-point output source I/O Unit.
Flex Network 8-Point Input Sink Source / 8-Point Transistor Output Sink Type I/O Unit	FN-XY08TS41	8-point input sink-source and 8-point transistor output sink mixed I/O unit. Both DC24V input signals and DC24V output (load current: 200mA max.) devices can be connected.
Flex Network 16-Point Input Sink Source / 16-Point Transistor Output Sink Type I/O Unit	FN-XY16SK41	16-point input sink-source and 16-point transistor output sink mixed I/O unit. Both DC24V input signals and DC24V output (load current: 200mA max./1.6A/common) devices can be connected.
Flex Network 16-Point Input Sink Source/16-Point Transistor Output Sink Type I/O Unit	FN-XY16SC41	16-point input sink-source and 16-point transistor output source mixed I/O unit. Both DC24V input signals and DC24V output (load current: 200mA max./1.6A/common) devices can be connected.
Flex Network 32-Point Input Sink Source / 32-Point Transistor Output Sink Type I/O Unit	FN-XY32SKS41	32-point input sink-source and 32-point transistor output sink mixed I/O unit. Both DC24V input signals and DC24V output (load current: 200mA max./1.6A/common) devices can be connected.
Flex Network 8-Point Relay Output / 1 Common Type I/O Unit	FN-Y08RL41	8-point relay output(1 common)I/O Unit. Up to AC240V (1A) load current can be connected.

## ■ Analog Units

Product Name	Model No.	Description
Flex Network 2-Channel Analog/Digital Conversion Input Unit	FN-AD02AH41	Converts 2-channel analog signals to digital signals at 12-bit resolution.
Flex Network 2-Channel Digital/Analog Conversion Output Unit	FN-DA02AH41	Converts 2channel 12-bit digital signal to analog signal and sends output.
Flex Network 4-Channel Analog/Digital Conversion Input Unit	FN-AD04AH11	Converts 4-channel analog signals to digital signals at 12-bit resolution.
Flex Network 4-Channel Digital/Analog Conversion Output Unit	FN-DA04AH11	Converts 4-channel 12-bit digital signal to analog signal and sends output.

## ■ Positioning Units

Product Name	Model No.	Description
Flex Network Single-Axis Positioning Unit	FN-PC10SK41	Both of this unit and GLC/LT can store positioning data. Motor driver connection cable(FN-PC10CB01) is required.
Flex Network Teaching Loader for Single-Axis Positioning Unit	FN-PC10LD41	Programmer for Single-Axis Positioning Unit. Allows entry, editing and operation checking of high-precision positioning data (5m cable included)

## ■ High-Speed Counter Unit

Product Name	Model No.	Description
Flex Network High Speed Counter Unit	FN-HC10SK41	High performance High-Speed counter that can easily change counter input types. Can create both a wide range of data and cam output.

## ■ Expansion Unit

Certain GP70/77R Series expansion units can be used with the GLC unit. Please contact your local GLC distributor for details.

Product Name	Model No.	Description
VM Unit	GP2000-VM41	Video Capture Unit

## ■ CF Card Items

Product Name	Model No.	Description
CF Cards	CA3-CFCALL/64MB-01	GLC Series CF Card (64MB)
	CA3-CFCALL/128MB-01	GLC Series CF Card (128MB)
	CA3-CFCALL/256MB-01	GLC Series CF Card (256MB)
	CA3-CFCALL/512MB-01	GLC Series CF Card (512MB)
CF Card Adaptor	GP077-CFAD10	CF Card Adaptor for standard PC Card Slot.
CF Card Maintenance Unit <sup>*1, *2</sup>	GP077-CFFM10	Allows insertion or removal of a CF Card via the GLC units front panel.

1. Cannot be used for a GLC2400T unit.

2. This unit cannot be used at the same time as the BUS Conversion unit (PSL-CONV00).



## ■ Optional Items

Product Name	Model No.	Description
Screen Protection Sheet (5 sheets/set)	PS400-DF00(GLC2400T)	Disposable protective, dirt-resistant sheet for the GLC unit's screen. The GLC unit's touch panel can be used with this cover sheet attached.
	PSL-DF00(GLC2500T/GLC2600T)	
Flex Network Communication Cable	FN-CABLE2010-31-MS (10m)	Connect GLC/LT units with Flex Network units.
	FN-CABLE2050-31-MS (50m)	
	FN-CABLE2200-31-MS (200m)	
Motor Driver Connection Cable	FN-PC10CB01(1m)	Connects the Flex Network single-axis positioning unit and the servo and stepping drivers (under development).

# Chapter 1 – Introduction

## ■ Maintenance Items

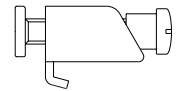
These are all original GLC standard equipment items. They are also available separately as optional maintenance items.

Product Name	Model No.	Corresponding GLC	Rev.	Description
	PS400-BU00-MS	GLC2400T Series	-	Replacement Backlight
	GP577RT-BL00-MS	GLC2500T Series	-	
	CA3-BLU12-01	GLC2600-TC41-24V	Rev.3 is marked.*1	
		GLC2600-TC41-200V	Rev.4 is marked.*1	
	PS600-BU00	GLC2600-TC41-24V	Rev.3 is not marked.*1	
		GLC2600-TC41-200V	Rev.4 is not marked.*1	
	GP070-AT01	GLC2400 Series GLC2500 Series GLC2600 Series	-	Fasteners to attach the GLC to a panel. (4 fasteners/set)
	PS400-WP00-MS	GLC2400 Series	-	Provides a moisture resistant seal when installing the GLC. Same as the seal included in the GLC unit's original equipment package.
	GP570-WP10-MS	GLC2500 Series GLC2600 Series	-	
Connector Cover	PS-BH01	GLC2400 Series GLC2500 Series GLC2600 Series	-	Protects GLC rear face connectors.
Screw Lock Terminal Block	GPM-AXCN01	GLC2400 Series GLC2500 Series GLC2600 Series	-	Terminal block for External Reset Input, Flex Network Communication, Sound Output.
Single-Axis Teaching Loader Cable	FN-LD10CBL (5m)	GLC2400 Series GLC2500 Series GLC2600 Series	-	Connects the Flex Network single-axis positioning unit and the single-axis teaching loader.

*\*1 The corresponding backlight unit differs depending on GLC2600 Series unit's marked Revision.*

**Reference** For more information on how to determine the revision version, see "Revision Version" (page 17).

## 1.4 GLC2000 Series Overview

---

The GLC2400T/GLC2500T/GLC2600T are equipped with a variety of new and useful features, such as an Ethernet, CF Card and Sound interfaces as standard equipment. The new GLC features are as follows:

### ■ Ethernet Feature

Your GLC2000 Series unit includes an Ethernet 10BASE-T connector as standard equipment. In addition to sending screen data to the GLC, you can use this feature to set up the GLC, even if you are using the unit for the first time\*<sup>1</sup>. Also, Pro-face's separately-sold Pro-Server software can read out data collected in the GLC to a central PC server via an Ethernet LAN network. And with a variety of software applications, you can process the data for production information management.

### ■ CF Card Feature

This interface allows you to use the CF Card instead of the optional Memory Loader II to store GLC setup\*<sup>1</sup> and screen data, and then transfer it to the GLC. You can also

read and write data to your existing (optional) multi-unit's CF Card, since the GLC unit's card is the same type. The CF Card can also be used to store and transfer recipe, logging, alarm history, and bmp data files. The GLC can read these files from the CF Card, or use the CF Card to store data read out from the host (PLC).

### ■ Sound Output I/F

With the GLC unit, you only need to connect a speaker to the GLC's sound output Terminal to enable sound output, without connecting the optional Multi Unit.

### ■ Expansion Serial Interface

This interface allows you to connect a variety of equipment, including a bar-code reader, a 2-D code reader or an I/O device.

### ■ Flex Network Communication I/F

A high speed remote (6Mbps/12Mbps) interface capable of connecting a maximum of 1008 I/Os.

### ■ Internal 2-Port Feature

The GLC unit's built-in 2-Port feature allows you to enjoy 2-Port operation with a Mitsubishi brand PLC, without using the optional 2-Port Adapter II unit.

### ■ Backlight Burnout Detection Feature

When the GLC's backlight burns out, it will be automatically detected. The GLC unit's "Status LED" will alert you that the backlight is burned out so that you can disable GLC Touch Panel Operation and prevent a possible GLC operation mistake.

Please read the following sections for detailed information about each feature.

---

*1. Setting up the GLC means downloading the required system and protocol programs from the GLC screen creation software to the GLC.*

---

# Chapter 1 – Introduction

## 1.4.1 Ethernet Connectivity

The GLC2000 Series units can be connected to a LAN or an Ethernet compatible PLC. The GLC2000 Series units also support the 2-way function.\*<sup>1</sup>

This feature allows you to setup a GLC and to also perform screen data transfer. You can even set up a completely new GLC via an Ethernet network.

**Reference** For details about setting up the GLC via an Ethernet network, refer to the **GP-PRO/PBIII for Windows Operation Manual** (included with the screen creation software).

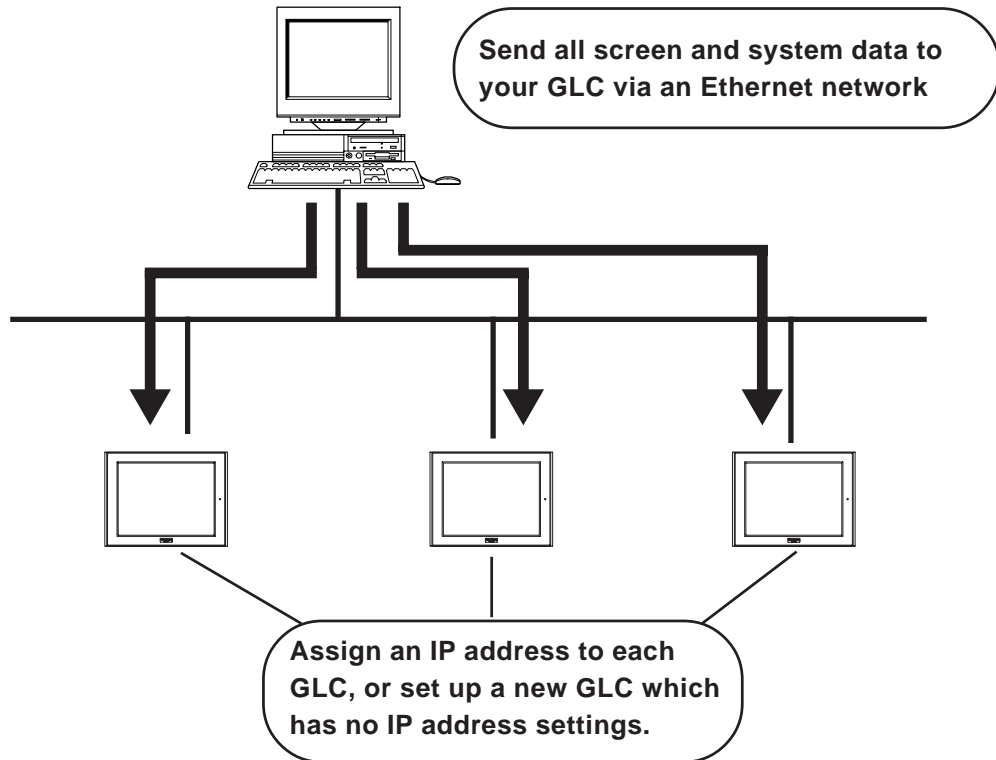

1. To use this feature, Pro-face's Pro-Server with Pro-Studio for Windows software (sold separately) is required.

## 1.4.2 CF Card

The new GLC2000 series unit allows you to use a CF Card. You can set up the GLC\*<sup>1</sup> or send screen data by saving backup data (all data necessary for GLC operation) in the CF Card using the GLC unit's CF Memory Loader Tool feature. As with the Multi Unit, the GLC2400 series unit includes all the following features:

- Read filing data from CF Card
- Write logging data to CF Card
- Read image data or sound data from CF Card
- Write Graph data or Alarm data to CF Card
- Back up screen data to CF Card

**Reference** *For details about creating / saving backup data (i.e. all necessary data for GLC operation) and sending GLC data, refer to **the GP-PRO/PBIII for Windows Operation Manual** (included with the screen creation software). For details about CF Memory Loader Tool's data upload and download, see **Section 4.3 – "CF Memory Loader Tool."***



**When using the CF Memory Loader Tool, Digital's GP077-CF20 (16MB)/ GP077-CF30 (32MB) Memory Card is required.**

### ■ Send GLC Screen Data to a CF card, then to other GLCs

The CF Card allows you to set up multiple GLCs using a single GLC unit's data. Copy your GLC data and the CF Memory Loader Tool to your GLC unit's CF Card, then insert that CF Card in another GLC and transfer that data using the CF Memory Loader Tool.

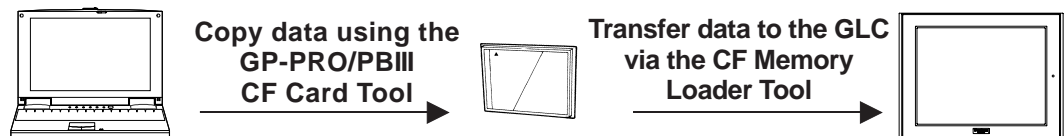

### ■ Send GLC Screen Data to a GLC, then to the CF card

You can also use the GLC as a CF Card drive for your PC, by sending data from your PC directly to your GLC unit's CF Card. Connect your PC and the GLC using the data transfer cable, and send your backup data and the CF Memory Loader Tool to the CF Card installed in the GLC.



**Note:** Transferring screen and system data to a GLC takes approximately fifteen minutes at a transmission speed of 115.2kbps.

*1. Setup means the sending of System and Protocol programs to the GLC unit via the screen creation software. This, in turn, allows you to use the GLC in the desired environment.*



# Chapter 1 – Introduction

## ■ Send Data from a GLC to a CF Card, then to another GLC

The CF Card allows you to use backup data saved in a GLC for setting up another GLC. First, upload (transfer) your GLC unit's backup data to your CF Card. Next, remove the CF Card, insert it in a different GLC and download (transfer) the CF Card's data to that GLC. Be sure that the CF Memory Loader Tool is saved on the CF Card prior to using this method.

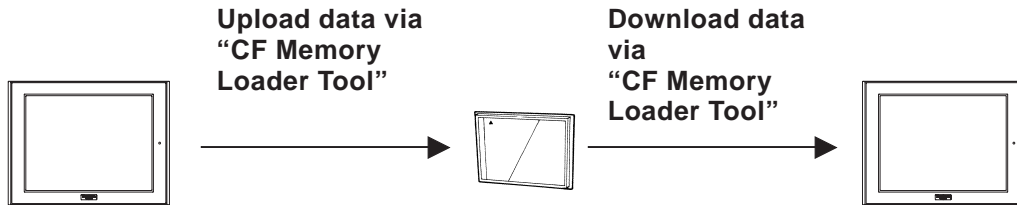

### 1.4.3 Sound Output

This feature allows you to connect a speaker to the GLC unit's Sound Output Terminal to produce sound output without using Pro-face's optional Multi Unit. This feature can be used when an operator wishes to create a sound-alarm or a sound-message, rather than only checking alarms or messages via the GLC screen. It can be also used as a machinery operation guide, or for multimedia.

**Reference** *"GP-PRO/PBIII for Windows Tag Reference Manual"* (included with the screen creation software package)

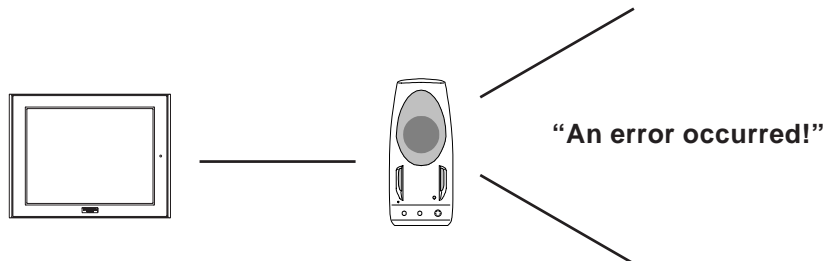

### 1.4.4 Expansion Serial I/F

The Expansion Serial Interface allows you to connect a bar-code reader, a 2-D code reader, or other type of I/O device. It enables the input/output of large volumes of data which cannot be handled with a conventional bar code reader interface.

Also, connecting an I/O device requires the creation of a data transfer protocol (via the D-Script feature).

**Reference** *"GP-PRO/PBIII for Windows Operation Manual"* (included with the screen creation software)

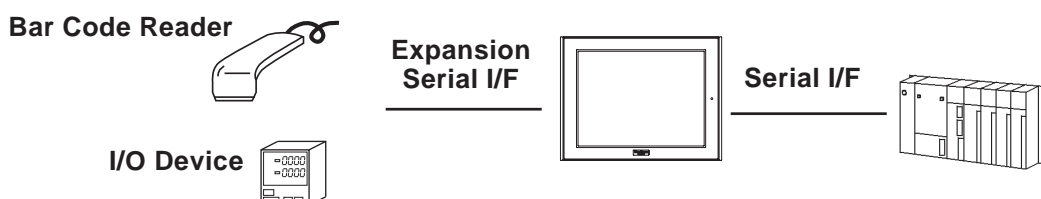

1.4.5 Flex Network Communication I/F

The following information explains how to connect the GLC to a Flex Network Communication I/F and I/O Unit.

When connecting the I/O unit, 2 lines are available - CH1 and CH2. Each channel outputs the same data and either can be used for data transmission.

The maximum number of connectable units, when using a single channel, is 31, and when using a second channel, the number increases by 32 to a total of 63.



The Flex Network uses high-speed data-transfer technology, and if a cable that is not recommended in this document is used for data transfer, network data-transfer performance cannot be guaranteed. Therefore, use only the cable(s) recommended here.

**Reference** Flex Network User Manual (sold separately)

■ Standard System Design

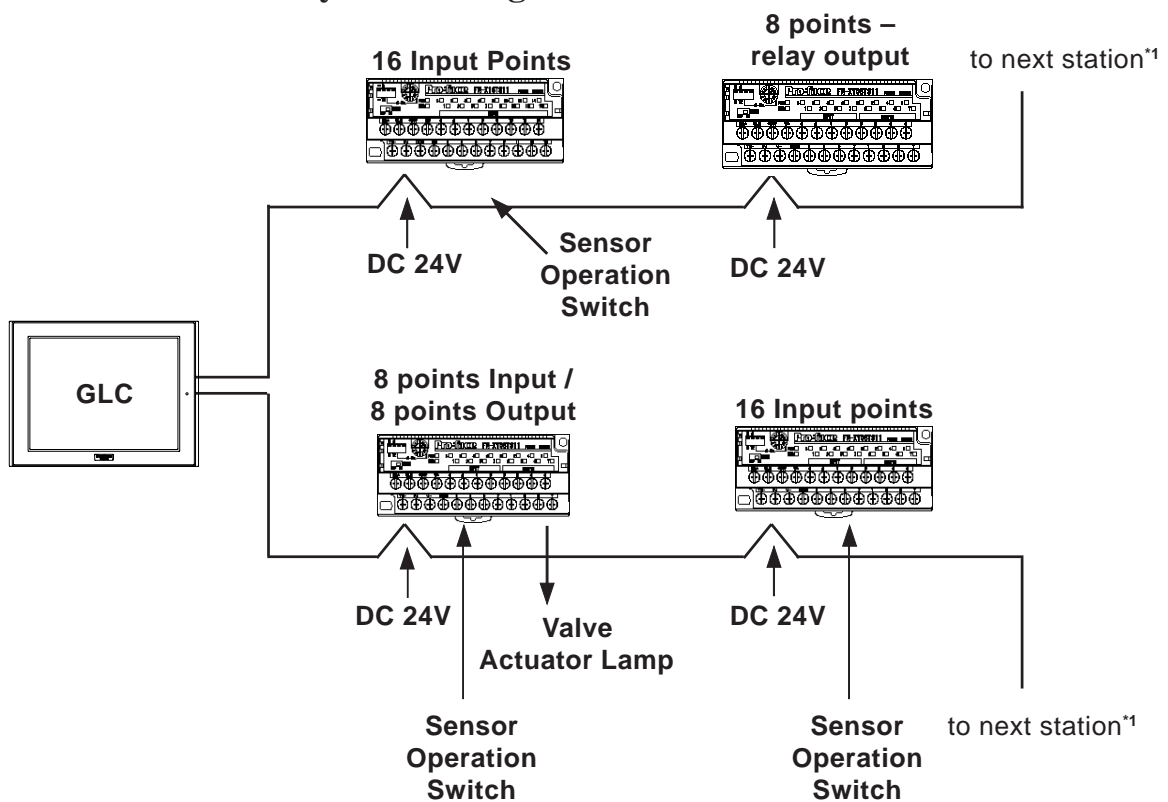

6 Mbps is the recommended speed.

1. Be sure the Terminal Switch (TERM) of the network's last unit (at each end) is turned ON.

**Reference** Flex Network User Manual (sold separately)

## Chapter 1 – Introduction

### 1.4.6 Printer / Serial Device / Tool Connector Interface

---

#### ■ Printer I/F

This interface is used to connect a printer to the GLC2400/GLC2600. Be sure to use the PSM-PRCB00 printer cable made by Digital Electronics Corporation.

▼**Reference**▲ See 2.3.2 – “Printer I/F”

#### ■ Serial I/F

This interface is used to connect RS-232C and RS-422 interface cables to a host (PLC).

▼**Reference**▲ See 2.3.1 – “Serial I/F”

#### ■ Tool Connector

This interface is used to connect a data transfer cable, a bar-code reader, or the Memory Loader II unit to the GLC2400/GLC2600.

▼**Reference**▲ See 2.2.5 – “Tool Connector”

### 1.4.7 Internal 2-Port Feature

---

The 2-Port feature allows you to use Mitsubishi’s GPP software package (ladder programming software) on your PC while the GLC is connected to a PLC. With a GLC2000 Series unit, you can use the 2-Port feature in the following two ways:

- Via the internal 2-Port feature  
The GLC’s Tool Connector and a PC are connected via a data transfer cable (GPW-CB02).
- Via the external 2-Port Adapter II  
Pro-face’s 2-Port Adapter II (GP070-MD11) is used.

▼**Reference**▲ For information about PLC types and GLC compatibility with GLC2000 Series units, refer to the **GP-PRO/PBIII for Windows Device/PLC Connection Manual** (included with the screen creation software)

#### ■ When Using Internal 2-Port feature\*1

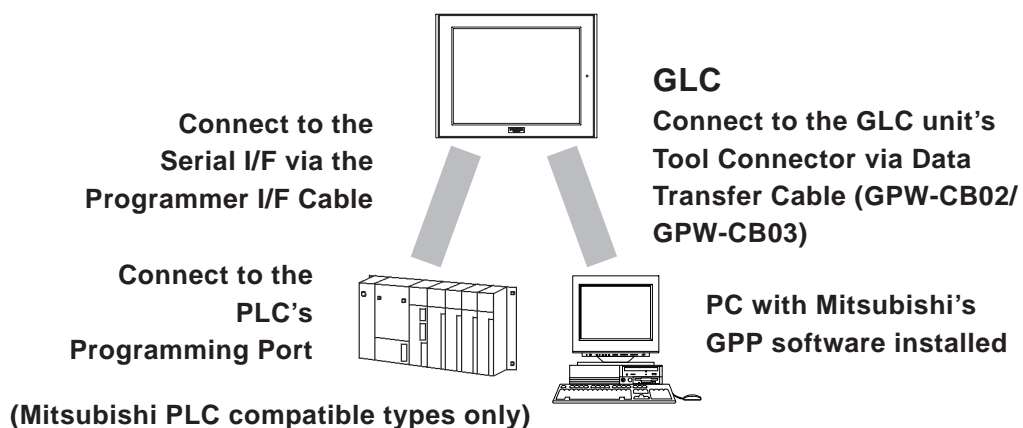

1. The Device Monitor feature can also be used at the same time.

▼**Reference**▲ For details about the device monitor function, refer to the **GP-PRO/PBIII for Windows Device/PLC Connection Manual** (included with the screen creation software).

## ◆ Internal 2-Port Feature Usage Notes

- To use the internal 2-Port feature, you will need to adjust your GLC's settings. For information about these settings, refer to

**Reference** *GP-PRO/PBIII for Windows Device/PLC Connection Manual*  
(included with the screen creation software)

- This feature can be used only while the GLC is in ONLINE mode.
- Since the internal 2-Port feature uses the GLC's single tool connector, you will not be able to use equipment which requires the tool connector (i.e. a bar-code reader, optional items, etc.)
- If you transfer screen data while the GLC is in ONLINE mode, the screen will not change to the data transfer screen automatically. Thus, you will need to change the screen manually to the OFFLINE mode's [Main Menu/ Transfer] screen.

**Reference** 4.1 – "Serial Data Transfer"

- Peripheral equipment, such as a Programming Console, is not compatible with the GLC unit's internal 2-Port feature. To use this type of equipment, you will need to use the external 2-Port Adapter II.

## ■ When Using the External 2-Port Adapter\*1

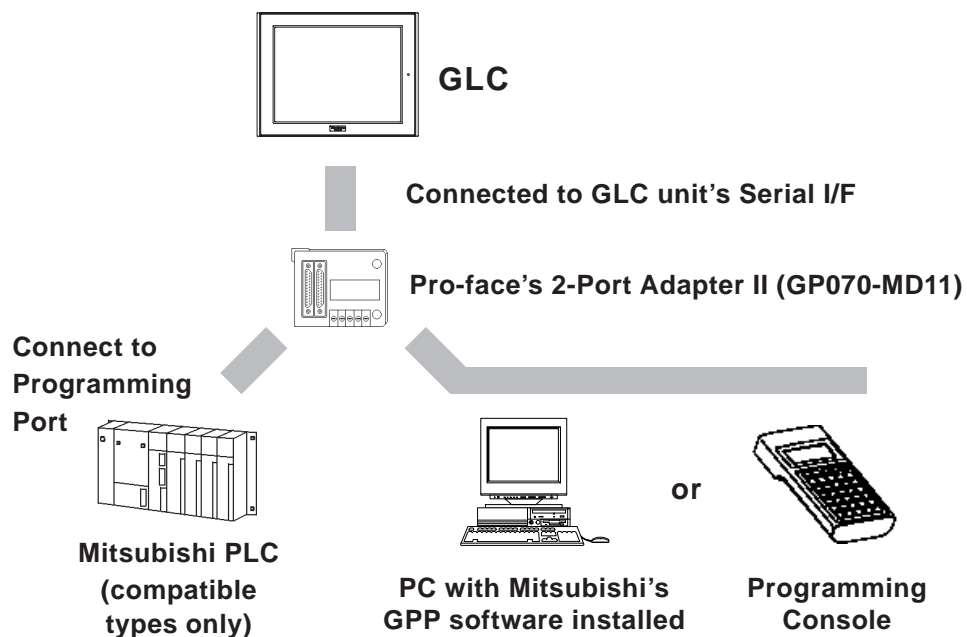

1. GLC2000 Series units can also use the 2-Port Adapter II.

**Reference** For details, refer to the *GP-PRO/PBIII for Windows Device/PLC Connection Manual* (included with the screen creation software).

## Chapter 1 – Introduction

### 1.4.8 Backlight Burnout Detection Feature

---

When the GLC unit's backlight burns out, it will be automatically detected. The GLC unit's Status LED will alert you that the backlight is burned out so that you can disable GLC Touch Panel Operation and prevent a possible GLC operation error. When Backlight Burnout is detected the GLC unit's Status LED will turn orange. Also, the system data area's Status bit10\*1 will turn ON.

**Reference** *For details about touch panel operation when the backlight burns out, see Section 6.4.3 – “Touch Panel Settings.”*



---

**Since the GLC monitors current consumption to detect if the backlight has burned out, in certain cases detection may not be possible.**

---



When a major logic program error occurs, depending on the type of error, the LED turning red can become a priority.

In some cases, even though a backlight burnout has been detected, the backlight may remain faintly lit. In this case, change the backlight as quickly as possible.

- 
1. When using the Direct Access method, bit +6 will turn ON. The using Memory Link method, bit 11 will turn ON.

**Reference** *For details, refer to the GP-PRO/PBIII for Windows Device/PLC Connection Manual (included with the screen creation software)*

---

# Chapter 2 Specifications

1. General Specifications
2. Functional Specifications
3. Interface Specifications
4. Part Names and Functions
5. Dimensions

## 2.1 General Specifications

---

### 2.1.1 Electrical

---

#### ■ GLC2500-TC41-200V/GLC2600-TC41-200V

	GLC2500-TC41-200V	GLC2600-TC41-200V
<b>Rated Voltage</b>	AC100 to 240V	
<b>Rated Voltage Range</b>	AC85 to 265V	
<b>Allowable Voltage Drop</b>	20ms or less	
<b>Power Consumption</b>	50VA or less (ACIN100V) 85VA or less (ACIN240V)	
<b>Voltage Endurance</b>	AC1,500V 20mA for 1 minute (between charging and FG terminals)	
<b>Insulation Resistance</b>	10M $\Omega$ or more at DC500V (between charging and FG terminals)	

#### ■ GLC2400-TC41-24V/GLC2500-TC41-24V/GLC2600-TC41-24V

	GLC2400-TC41-24V	GLC2500-TC41-24V	GLC2600-TC41-24V
<b>Rated Voltage</b>	DC 24V		
<b>Rated Voltage Range</b>	DC19.2V to DC28.8V		
<b>Allowable Voltage Drop</b>	10ms or less		
<b>Power Consumption</b>	28W or less	50W or less	
<b>In-Rush Current</b>	30A or less		
<b>Voltage Endurance</b>	AC1,000V 20mA for 1 minute (between charging and FG terminals)		
<b>Insulation Resistance</b>	10M $\Omega$ or more at DC500V (between charging and FG terminals)		

## Chapter 2 – Specifications

### 2.1.2 Environmental

<b>Ambient Operating Temp.</b>	0°C to +50°C*1
<b>Storage Temperature</b>	-20°C to +60°C
<b>Operating Humidity</b>	10%RH to 90%RH (non-c-condensing, wet bulb temperature: 39°C or less)
<b>Storage Humidity</b>	10%RH to 90%RH (non-c-condensing, wet bulb temperature: 39°C or less)
<b>Air Purity (Dust)</b>	0.1mg/m <sup>3</sup> or less (non-conductive levels)
<b>Pollution Degree</b>	Pollution Degree 2
<b>Corrosive Gasses</b>	Free of corrosive gasses
<b>Atmospheric Endurance (GLC Operation Altitude)</b>	800hPa to 1,114hPa (2000 meters or lower)
<b>Shock Resistance</b>	IEC61131-2 (JIS B 3501) compliant 147m/s <sup>2</sup> Release time 11ms Twice in each of X, Y, Z directions
<b>Vibration Resistance</b>	IEC61131-2 (JIS B 3501) compliant When vibration is NOT continuous 10Hz to 57Hz 0.075mm, 57Hz to 150Hz 9.8m/s <sup>2</sup> When vibration is continuous 10Hz to 57Hz 0.035mm, 57Hz to 150Hz 4.9m/s <sup>2</sup> X, Y, Z directions for 10 times (80min.)
<b>Noise Immunity (via noise simulator)</b>	Noise Voltage: 1,500Vp-p, Pulse Duration: 1μs Rise Time: 1ns
<b>Electrostatic Discharge Immunity</b>	Contact Discharge Method 6kV (complies with IEC 61000-4-2 Level 3)

1. When the GLC2600T operates for a long time in ambient temperatures that are greater than 40°C, the screen's crystal liquid may become temporarily cloudy. This liquid will return to its original condition at normal temperature, and no operation problems will result.

### 2.1.3 Structural

	GLC2400T	GLC2500T	GLC2600T
<b>Grounding</b>	100Ω or less, or your country's applicable standard		
<b>Ratings</b> *1	Equivalent to IP65f (JEM 1030) NEMA#250 Type4X/12		
<b>External Dimensions</b>	W215mm x H170mm x D60mm [8.46 x 6.69 x 2.36 in.]	W317mm x H243mm x D58mm [12.48 x 9.57 x 2.28 in.]	
<b>Weight</b>	1.7 kg (3.7lb) or less	3.5 kg (7.72lb) or less	
<b>Cooling Method</b>	Natural air circulation		

1. The front face of the GLC is installed in a solid panel. The GLC unit's level of resistance and the conditions it has been tested under are equivalent to the standards listed in the specifications. Oils that should have no effect on the GLC can harm the unit — when vaporized oils are present, when low-viscosity cutting oils are allowed to adhere to the unit for a long time, or if the protective sheet on the front face of the GLC peels off. These conditions can lead to the ingress of oil into the GLC, and alternate protective measures are suggested. To prevent deformation or corrosion of the front panel's plastic cover due to the presence of non-approved oils, confirm the operating environment conditions prior to installing the GLC. If the installation gasket is used for a long time, or if the unit and its gasket are removed from the panel, the original level of the protection cannot be guaranteed. To maintain the original protection level, replace the installation gasket regularly.

## 2.2 Functional Specifications

### 2.2.1 Display

	GLC2400T	GLC2500T	GLC2600T
<b>Type</b>	TFT type color LCD		
<b>Resolution</b>	640 x 480pixels		800 x 600pixels
<b>Effective Display Area</b>	W149.8mm x H112.3mm [5.90 x 4.42in.]	W211.2mm x H158.4mm [8.31 x 6.24in.]	W246.0mm x H184.5mm [9.69 x 7.27in.]
<b>Colors</b>	256/No blink <sup>1</sup> 64 colors/3-speed blink (Color switching is done via software)		
<b>Backlight</b>	CCFL (Service life: 50,000 hrs. at 25°C and 24hr. operation)		
<b>Brightness Control</b>	4 levels of adjustment available via touch panel.		
<b>Language Fonts</b>	ASCII: (Code page 850) Alphanumeric (incl. Eur. characters) Chinese: (GB2312-80 codes) simplified Chinese fonts Japanese: ANK 158, Kanji : 6962 (JIS Standards 1 & 2) Korean: (KSC5601 - 1992 codes) Hangul fonts Taiwanese: (Big 5 codes) traditional Chinese fonts		
<b>Character Sizes</b> <sup>*2</sup>	8X8 dot font, 8X16 dot font, 16X16 dot font and 32X32 dot font		
<b>Font Sizes</b>	Height can be expanded 1 to 8 times. Width can be expanded 1/2 <sup>*3</sup> , 1 to 8 times.		
<b>Text</b>	<b>8x8 dots</b>	80 Char. x 60 rows	100 Char. x 75 rows
	<b>8x16 dots</b>	80 Char. x 30 rows	100 Char. x 37 rows
	<b>16x16 dots</b>	40 Char. x 30 rows	50 Char. x 37 rows
	<b>32x32 dots</b>	20 Char. x 15 rows	25 Char. x 18 rows

1. Changing the Colors setting to “256 colors” will disable the blink feature on all screens in your project. If you wish to use the blink feature, do not change this setting to “256 colors.”
2. The display font will differ depending on the character (language) or size you select.

**Reference** Chapter 6.8 – “SET UP SCREEN”

3. Only available when using “Half-2 Byte Character” settings via software.  
(Only Chinese, Taiwanese, and Korean OS)



## Chapter 2 – Specifications

### 2.2.2 Memory

<b>Application</b>	4MB FLASH EPROM (Approx. 1280 screens at 3.2KB/screen)
<b>Data Backup</b>	256KB SRAM (uses lithium battery) <sup>*1</sup>

### 2.2.3 Control Memory

<b>Variable Area</b>	SRAM Max. 64KB. However, size varies depending on main unit revision code and software settings. Lithium battery is used to retain variable data <sup>*1</sup>
<b>Program Area</b>	FLASH EPROM 128KB



**Note:**

- Refer to Pro-Control Editor manual for SRAM (size) usage details.
- 128KB of SRAM is reserved for the Online Editor.

### 2.2.4 Resolutino / Clock

	<b>GLC2400T</b>	<b>GLC2500T</b>	<b>GLC2600T</b>
<b>Resolution</b>	32 x 24 keys/screen (1 or 2 point touch)		40 x 30 keys/screen (1 or 2 point touch)
<b>Clock Accuracy</b>	± 65 seconds/month (at room temperature)		



**Note:**

The GLC unit's internal clock has a slight error. At normal operating temperatures and conditions, with the GLC operating from its lithium battery, the degree of error is 65 seconds per month. Variations in operating conditions and battery life can cause this error to vary from -380 to +90 seconds per month. For systems where this degree of error will be a problem, the user should be sure to monitor this error and make adjustments when required.

**Reference** Chapter 6.7 – “SET UP TIME”

1. A Lithium battery's lifetime is:

- 10 years when the battery's ambient temperature is under 40 °C
- 4.1 years when the battery's ambient temperature is under 50 °C
- 1.5 years when the battery's ambient temperature is under 60 °C

When used for backup: (without main power)

- Approximately 60 days, with a fully charged battery
- Approximately 6 days, with a 10% charged battery

### 2.2.5 Interfaces

<b>Serial Interface</b>	Asynchronous Transmission: RS-232C/RS-422 Data Length: 7 or 8 bits Stop Bit: 1 or 2 bits Parity: None, Odd or Even Data Transmission Speed: 2,400 to 115,200bps	
<b>Expansion Serial Interface</b>	Asynchronous Transmission: RS-232C Data Length: 7 or 8 bits Stop Bit: 1 or 2 bits Parity: None, Odd or Even Data Transmission Speed: 2,400 to 38,400bps	
<b>Ethernet Interface</b>	IEEE802.3, 10BASE-T	
<b>Tool Connector</b>	Asynchronous TTL level nonprocedural command I/F <During screen file development> Used for transferring data between the GLC application software and the GLC. Used for data transfer with the 2-Port feature. <During Logic Program Development> Used for transferring data between the Logic Program Development software and the GLC. <During RUN Mode> Used for a variety of devices, including bar-code readers.	
<b>CF Card Interface</b>	1 slot	
<b>Expansion CF Card Interface</b>	Connector used for attaching the CF Card Front Maintenance Unit. (Not available with GLC2400T)	
<b>Printer Interface</b>	Compatible with NEC PC-PR201/PL, EPSON ESC/P24-J84(c), HP Laser Jet PCL 4 command EPSON PM/Stylus (6-color ink), EPSON Stylus (4-color) compatible printers <sup>*1</sup>	
<b>Screw Lock Terminal Block</b>	<b>External Reset Input I/F</b>	Remote Reset Input                      1 point Input Voltage                                DC24V ±10% Input Current                                4mA (TYP) Min. Input Pulse Width                    2ms Operating Voltage (When ON)            Min. DC21.2V Operating Voltage (When OFF)            Max. DC3V Isolation Method                            Photocoupler Isolation
	<b>Flex Network Communication I/F</b>	Communication Style: 1:N Connection Format: Multi Drop Connection Communication Range: 200m/CH at 6Mbps, 100m/CH at 12Mbps Communication Format: Cyclic Data Transfer, Half-duplex Communication Speed: 6Mbps, 12Mbps  Communication I/F: Differential method, Pulse Transformer Insulation method Error Check: Format Test, Bit Test, CRC-12 Test Number of connection stations: Maximum 63 stations Number of I/O points: 1008
	<b>Sound Output</b>	External Speaker Connection (Terminal Block) Monaural 1CH Speaker Output 70mW (Rated Load: 8Ω, Frequency: 1kHz) Sound Line Out Output: 2.7Vp-p (Rated Load:10kΩ) Recommended wire: AWG#28 to #16

*1. Certain types of printers with both Windows and DOS drivers can be used, but not those with Windows-only drivers. Contact your local GLC distributor for details.*

## 2.3 Interface Specifications

### 2.3.1 Serial Interfaces

This interface can be either RS-232C or RS-422. Connects GLC to Host (PLC). This interface uses a socket-type connector.

Pin Assignments	Pin #	Signal Name	Condition
	1	FG	Frame ground
	2	SD	Send data (RS-232C)
	3	RD	Receive data (RS-232C)
	4	RS	Request send (RS-232C)
	5	CS	Clear send (RS-232C)
	6	DR	Data Set Ready (RS-232C)
	7	SG	Signal ground
	8	CD	Carrier detect (RS-232C)
	9	TRMX	Termination (RS-422)
	10	RDA	Receive data A (RS-422)
	11	SDA	Send data A (RS-422)
	12	NC	No connection (Reserved)
	13	NC	No connection (Reserved)
	14	VCC	5V±5% output 0.25A
	15	SDB	Send data B (RS-422)
	16	RDB	Receive data B (RS-422)
	17	RI	Ring Indicate (RS-232C)
	18	CSB	Clear send B (RS-422)
	19	ERB	Enable receive B (RS-422)
	20	ER	Enable receive (RS-232C)
	21	CSA	Clear send A (RS-422)
	22	ERA	Enable receive A (RS-422)
	23	NC	No connection (Reserved)
	24	NC	No connection (Reserved)
	25	NC	No connection (Reserved)

#### Recommended Parts

Connector	Dsub25pin plug	XM2A-2501	(OMRON)
Cover	Dsub25pin cover	XM2S-2511	(OMRON)
	Jack Screws	XM2Z-0071	(OMRON)
Cable	CO-MA-VV-SB5PX	28AWG	(Hitachi Cable Ltd.)



Use rough metric type M2.6x0.45 p threads used to secure the cable's set screws.

**Reference** To confirm your PLC's connection specifications, refer to the **GP-PRO/PBIII for Windows Device/PLC Connection Manual** (included with the screen creation software)



Use the following instructions to create your own cable:

With an RS-422 cable:

- The following pins must be shorted as follows:  
 #18 (CSB) <—> #19 (ERB)  
 #21 (CSA) <—> #22 (ERA)
- Connecting the RS-422 cable’s #9 (TRMX) and #10 (RDA) pins inserts a termination resistance of 100Ω between #10 (RDA) and #16 (RDB).
- When making a cable for a Memory Link system, use a 4-wire type cable.

With an RS-232C cable:

- Do NOT use the following pins:  
 #9 (TRMX), #10 (RDA), #11 (SDA), #15 (SDB), #16 (RDB), #18 (CSB), #19 (ERB), #21 (CSA), #22 (ERA)
- Connect the #1 (FG) terminal only if it is required by a connected device.



- **This GLC unit’s serial port is not isolated. When the host (PLC) unit is also not isolated, and to reduce the risk of damaging the RS-422 circuit, be sure to connect the #7 SG (Signal Ground) terminal.**
- **Pin #14 (VCC) DC 5V Output is not protected. To prevent damage or unit malfunction, use only the designated level of current.**

### ■ Expansion Serial Interface

This interface is used for RS-232C data transfer, and uses a plug-type connector.

Pin Assignments	Pin No.	Signal Name	Signal Direction	Condition
	1	CD	Input	Carrier detect (RS-232C)
	2	RD	Input	Receive data (RS-232C)
	3	SD	Output	Send data (RS-232C)
	4	ER	Output	Enable receive (RS-232C)
	5	SG	—	Signal Ground
	6	DR	Input	Data Set Ready (RS-232C)
	7	RS	Output	Request Send (RS-232C)
	8	CS	Input	Clear send (RS-232C)
	9	R/VCC	Input/Output	Ring Indicate (RS-232C) +5V+5% 0.25A

### Recommended Parts

- |             |                            |         |
|-------------|----------------------------|---------|
| Connector   | Dsub 9pin socket XM2D-0901 | (OMRON) |
| Cover       | Dsub 9pin cover XM2S-0913  | (OMRON) |
| Jack Screws | XM2Z-0073                  | (OMRON) |



Use inch type set screws (#4-40 UNC).



**Pin #9 (VCC) DC 5V Output is not protected. To prevent damage or unit malfunction, use only the designated level of current.**

## Chapter 2 – Specifications

### 2.3.2 Printer Interface

When connecting a printer, use Digital's printer cable (PSM-PRCB00).

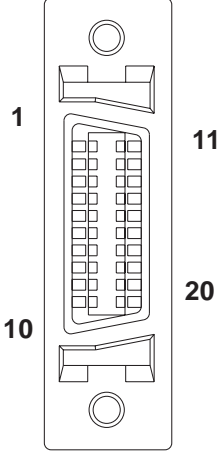
Pin Assignments	Pin #	Signal Name	Condition
	1	GND	Ground
	2	RESERVE	Reserved
	3	PDB5	Data Signal
	4	PDB4	Data Signal
	5	PDB3	Data Signal
	6	GND	Ground
	7	SLCT	Select Status (Input)
	8	PDB0	Data Signal
	9	PSTB	Strobe Signal (Output)
	10	BUSY	Busy Signal (Input)
	11	PDB7	Data Signal
	12	PDB6	Data Signal
	13	GND	Ground
	14	ERROR	Printer Error (Input)
	15	GND	Ground
	16	PDB2	Data Signal
	17	PDB1	Data Signal
	18	PE	Paper Runout
	19	INIT	Initialization Signal (Output)
	20	GND	Ground

### 2.3.3 External Reset Input I/F, Flex Network Communication I/F, and Sound Output I/F

This interface is used for external reset, Flex Network, or sound output.

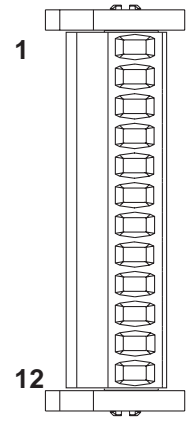
Pin Assignments	Pin #	Signal Name	Condition
	1	AUXCOM	External Reset Common
	2	AUXRESET	External Reset Input
	3	TR+	CH1 Communication Data
	4	TR-	CH1 Communication Data
	5	SLD	CH1 Cable Shield Line
	6	TR+	CH2 Communication Data
	7	TR-	CH2 Communication Data
	8	SLD	CH2 Cable Shield Line
	9	RESERVE	Reserve
	10	SP OUT	Speaker Output
	11	GND	Ground
	12	LINE OUT	Sound Lineout Output

Torque : 0.2 to 0.4 N•m

Wire Gauge : AWG16 to AWG28

Removed Wire Length :  $7 \pm 0.5\text{mm}$  [ $0.28 \pm 0.02\text{ in.}$ ]

■ External Reset Input Circuit

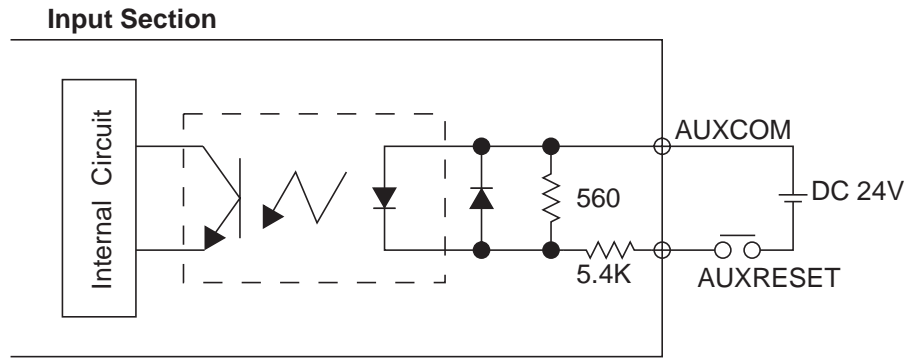

- Input Voltage : DC24V ± 10%
- Input Current : 4mA(TYP)/DC24V
- Minimum Input Pulse Width : 2ms
- Operating Voltage : Power ON Minimum DC21.2V  
Power OFF Maximum DC3V
- Isolation Method : Photocoupler isolation

## 2.4 Part Names and Functions

**A: Display Panel**

The GLC monitor screen displays user-created screens and corresponding host (PLC) data.

- GLC2400T TFT type color LCD
- GLC2500T TFT type color LCD
- GLC2600T TFT type color LCD

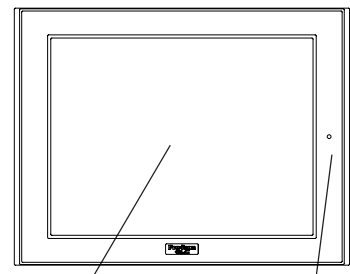

**Front  
(all units)**

**B: Touch Panel**

Enables the user to perform screen change operations or input data.

**C: Status LED**

Indicates the GLC unit's current condition.

Color	Indicator	Operation Mode	Controller Operation Mode
Green	ON	OFFLINE	---
	ON	In operation	RUN
	Flashing	In operation	STOP
Red	ON	In operation	Major Error

Color	Indicator	Meaning
Orange	ON	Backlight burnout has occurred.

## Chapter 2 – Specifications

### D: Expansion CF Card Interface\*<sup>1</sup>

Connects the CF Card front maintenance unit (available only with GLC2500T/GLC2600T).

### E: Expansion Unit Interface 1

Connects a data communication unit to the GLC.

### F: Expansion Unit Interface 2\*<sup>1</sup>

Connects a unit to expand display features (available only with GLC2500T/GLC2600T).

### G: Power Input Terminal Block

Connects Power Cord.

### H: CF Card Cover

Protects the CF Card interface and the CF Card from contamination. When opened, the GLC unit's Dip Switches can be seen.

### I: CF Card Access LED

If the CF Card Cover is closed when the CF Card is inserted, the LED lamp turns ON. The LED lamp will remain turned ON even if the CF Card Cover is opened while the GLC accesses the CF Card.

### J: CF Card Interface

Insertion slot for CF Card.

### K: Screw Lock Terminal Block

Used for external reset, alarm output, buzzer output, and sound output.

### L: Serial Interface

RS-232C/422 Interface. Connects to a host PLC.

### M: Expansion Serial Interface

RS-232C Interface.

### N: Tool Connector

Connects to Transfer Cable, Bar Code Reader or Memory Loader II.

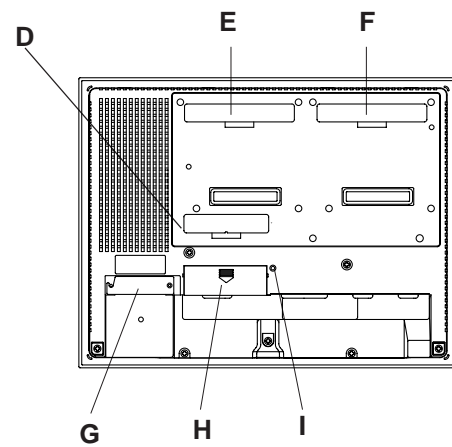

Rear  
(GLC2500T/GLC2600T)

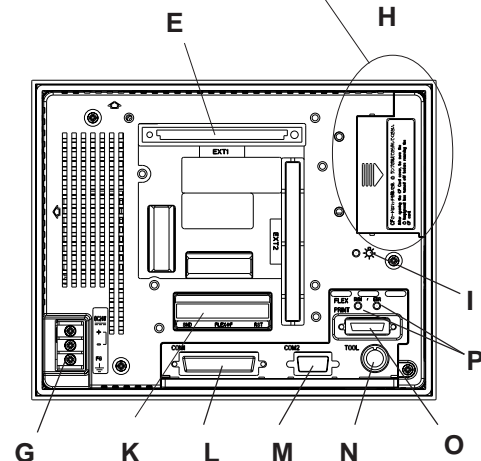
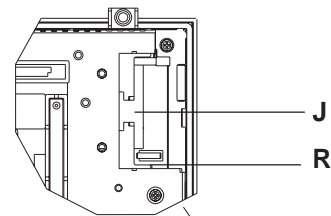

Rear  
(GLC2400T)

1. This unit cannot be used with the BUS Conversion unit (PSL-CONV00) at the same time since the connector part is blocked.

## Chapter 2 – Specifications

### O: Printer Interface

Connect the printer cable here. Recommended cable: Digital Electronic Corporation PSM-PRCB00 Cable.

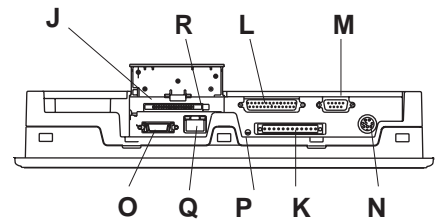

**Bottom  
(GLC2500T/GLC2600T)**

### P: Flex Network Interface

Flex Network I/F status LED will turn ON or flash, according to the unit's status.

Status LED	Contents
RUN (Green)	Turns on when Communication is enabled.
ERR (Red)	Turns on when failure occurs in connected I/O Unit.

### Q: Ethernet Interface

Used for Ethernet (10BASE-T).

The LED will change (turn ON, blink) according to the GLC unit's status.

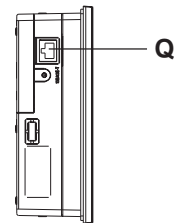

**Side (GLC2400T)**

Status LED	Display	Contents
Orange	ON	Power ON
	Flash	Send/Receive
Green	ON	Link

### R: Dip Switches

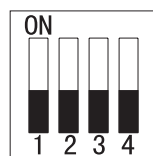

Dip Switch	Description	ON	OFF	Remarks
1	CF Card starting setting. Starting control from CF Card.	Can start from CF Card.	Cannot start from CF Card.	Requires CF Card to be able to start.
2	(Reserved)	—	—	Fix switches at "OFF".
3	(Reserved)	—	—	
4	Forcible closing setting of the CF Card cover.	Forcible closing enabled.	Forcible closing disabled.	For emergency treatment when the CF Card's hatch broke.



## 2.5 Dimensions

---

### 2.5.1 GLC2400T External Dimensions

---

Unit: mm [in.]

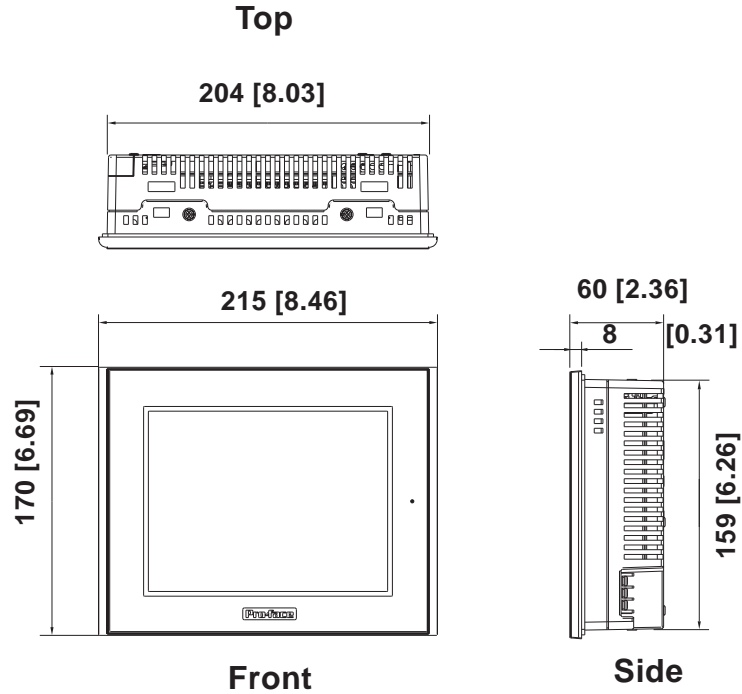

The following drawing shows the GLC2400T Series unit with installation fasteners.

Unit: mm [in.]

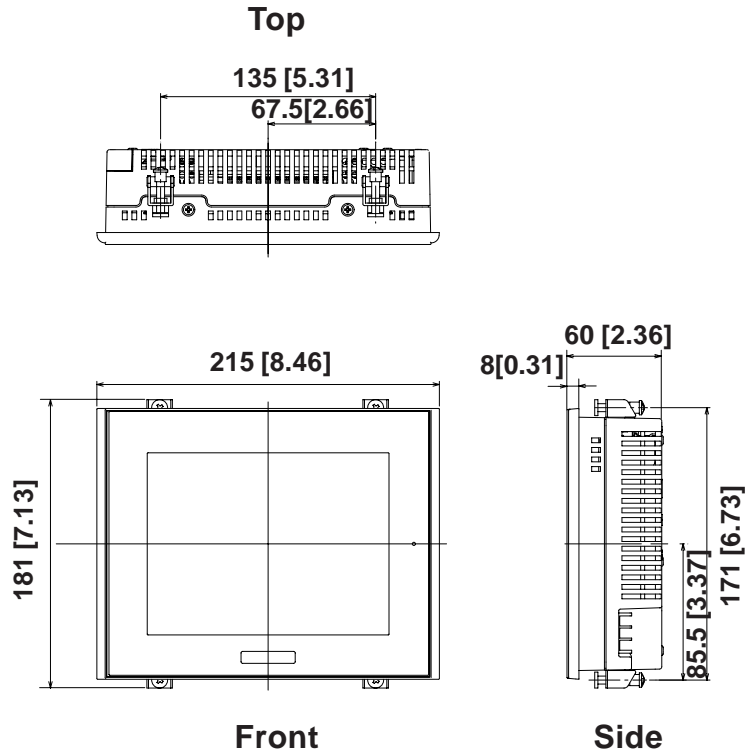

2.5.2 GLC2500T/GLC2600T External Dimensions

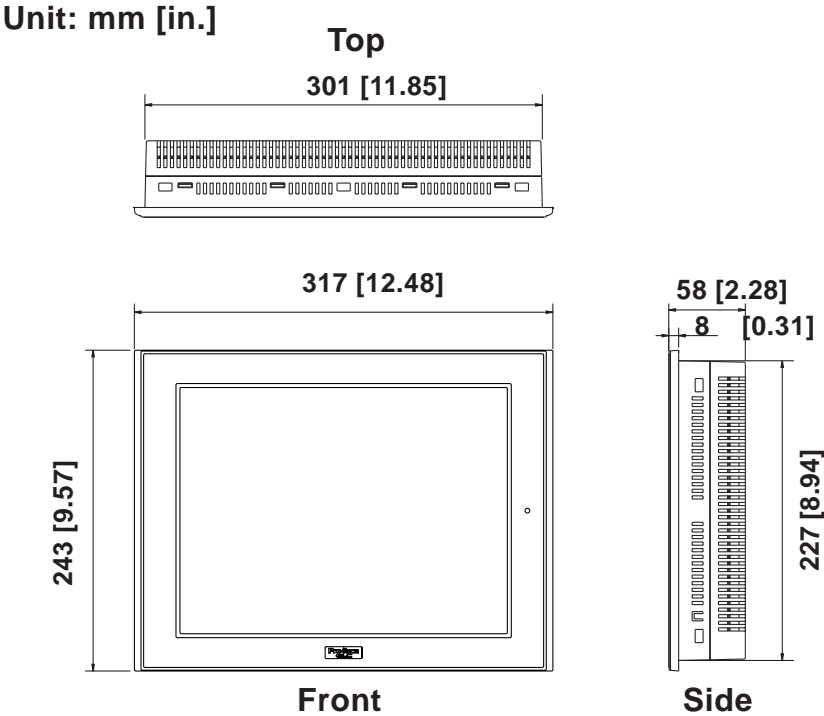

**Note:** The External Dimensions for the GLC2500T and GLC2600T Series units are commonly shown here. However, each has a different Effective Display Area size. For the details, **Reference** 2.2.1 Display

The following drawing shows the GLC2500T/GLC2600T Series unit with installation fasteners.

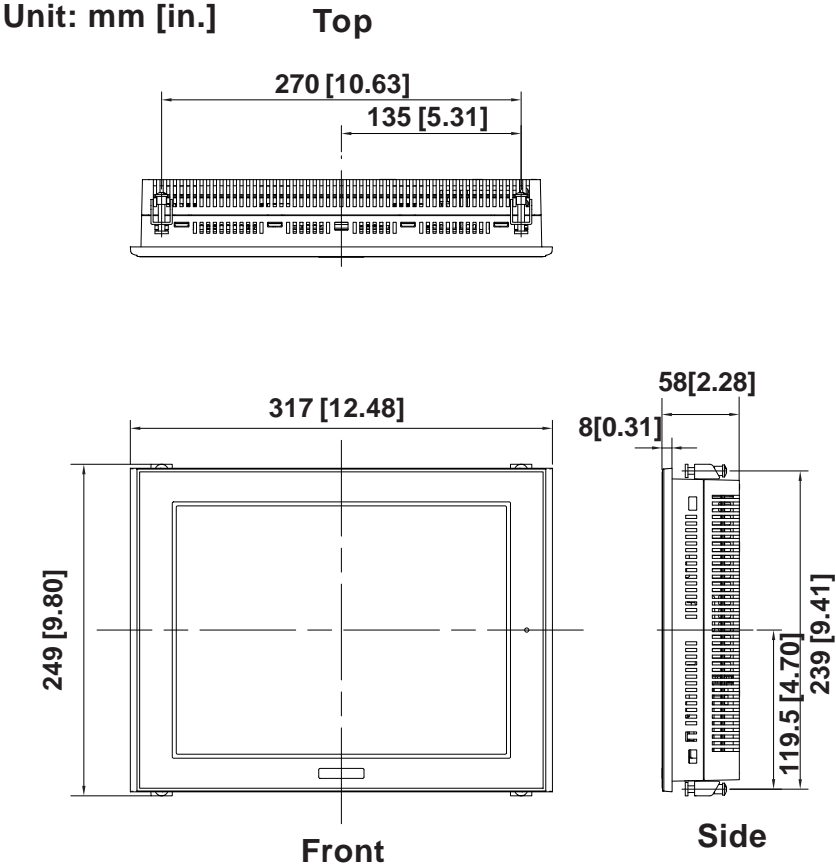

## Chapter 2 – Specifications

### 2.5.3 Installation Fasteners

---

Unit: mm [in.]

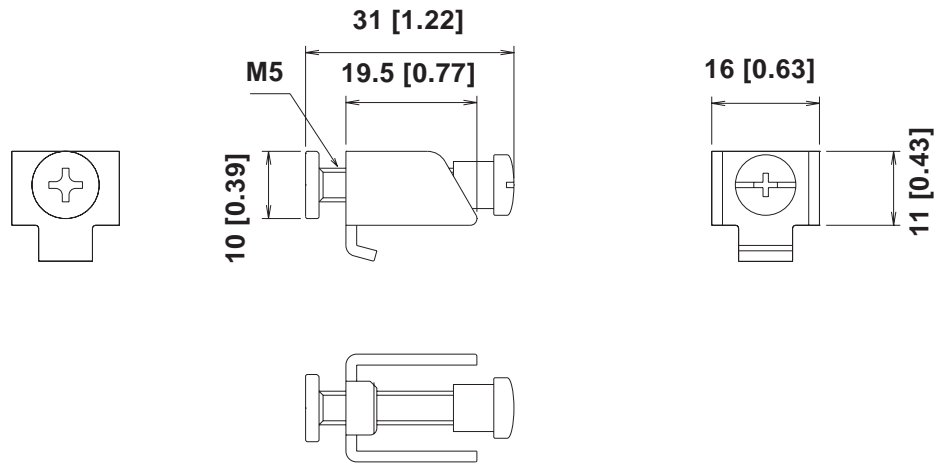

### 2.5.4 Panel Cut Dimensions

---

#### ■ GLC2400T

Unit: mm [in.]

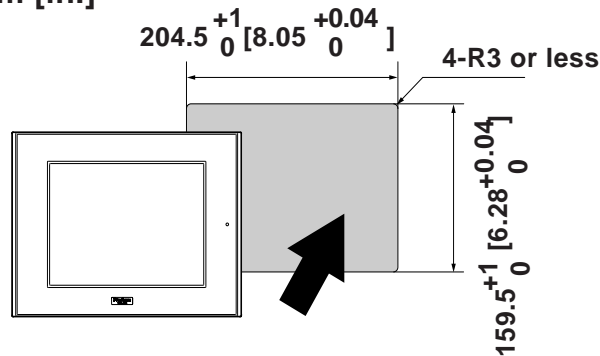

#### ■ GLC2500T/GLC2600T

Unit: mm [in.]

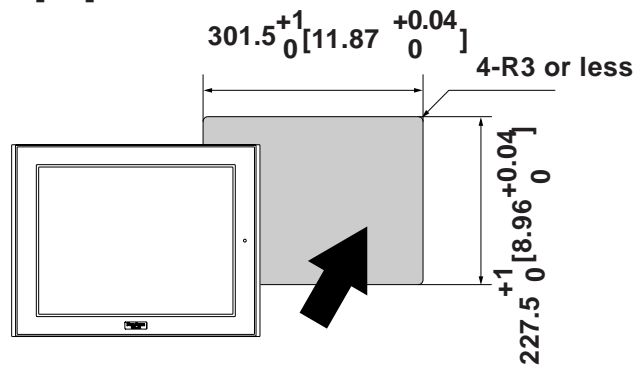

# Chapter

## 3 Installation and Wiring

1. Installation
2. Wiring Cautions
3. Tool Connector
4. Ethernet Cable Connector
5. CF Card Insertion and Removal
6. Connecting to the Screw Lock Terminal

### 3.1 Installation

---

#### 3.1.1 Installation Procedures

---

Follow the steps in this section to install the GLC.

##### ■ Attaching the Installation Gasket

Pro-face strongly recommends that you use the installation gasket to absorb vibration as well as repel water.

Place the display panel of the GLC face down on a level surface. Make sure that the GLC unit's installation gasket is securely fitted into the groove that runs around the perimeter of the panel's frame.

**Reference** *For details about installing the gasket, see Section 8.1.2 – “Installation Gasket Check/Replacement.”*

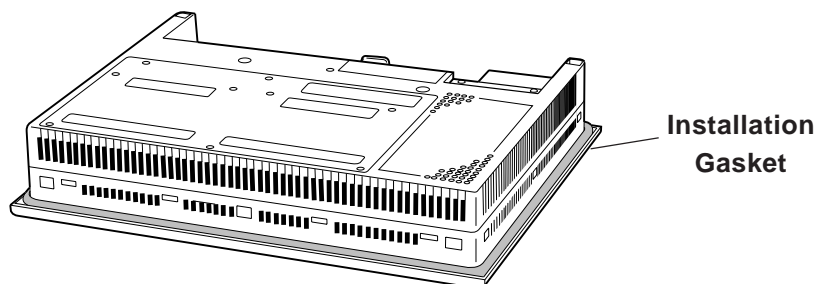

---

**Before installing the GLC into a cabinet or panel, check that the Installation gasket is securely attached to the unit.**

---

## Chapter 3 – Installation and Wiring

### ■ Creating a Panel Cut

Create an opening with the correct dimensions to install the GLC.

**Reference** For the correct installation dimensions, see **Section 2.5.4 – “GLC Panel Cut Dimensions.”**

The installation gasket, installation fasteners, and attachment screws are all required when installing the GLC.

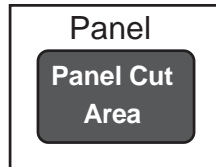

**Note:**

Make sure that the installation panel or cabinet's surface is flat, in good condition, and has no jagged edges. Metal reinforcement strips can also be attached to the inside of the panel, near the Panel Cut, to increase the panel's strength.



Panel thickness should be between 1.6 mm (0.06 in.) and 5.0 mm (0.2 in.), and should be based on the strength required to mount the GLC to the panel.

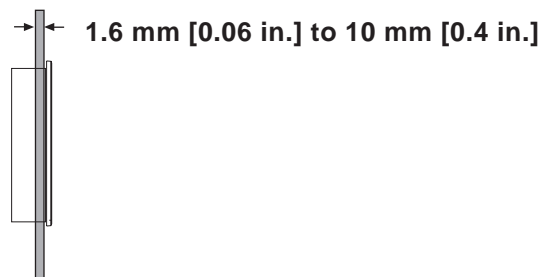

For easier maintenance and operation, and improved ventilation, install the GLC at least 100 mm (3.94 in.) away from adjacent structures and other equipment.

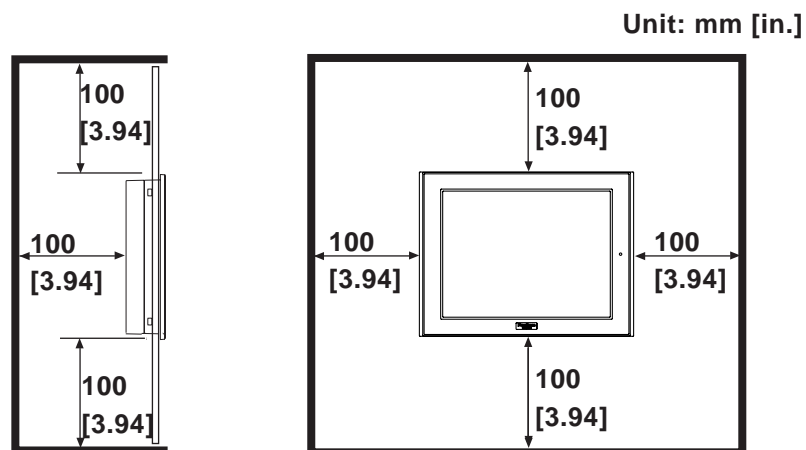



- Make sure that the ambient operation temperature and the ambient humidity are within their respective, designated ranges. (When installing the GLC in a cabinet or enclosure, the term “ambient operation temperature” indicates the cabinet or enclosure’s internal temperature.)

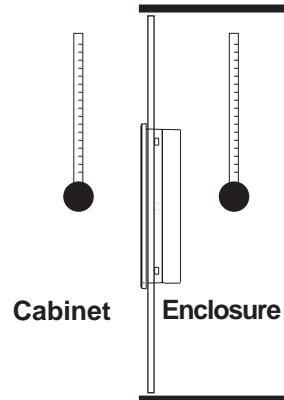

- Make sure that heat from surrounding equipment does not cause the GLC to exceed its standard operating temperature.
- When installing the GLC in a vertically-inclined panel, the panel’s face should NOT incline more than 30°.

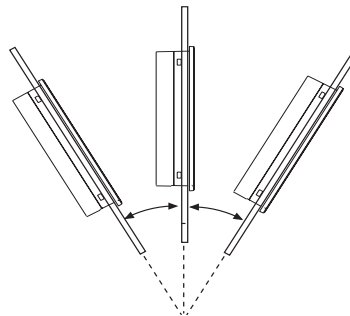

Less than 30° from vertical



- When installing the GLC in a vertically-inclined panel, and the panel’s face inclines more than 30°, the ambient temperature must NOT exceed 40° C. You may need to use forced air cooling (fan, A/C) to ensure the ambient operating temperature is lower than 40° C.
- When installing the GLC vertically, position the unit so that the Power Input Terminal Block is also vertical.

## Chapter 3 – Installation and Wiring

### ■ Installing the GLC

1. Insert the GLC into the panel cutout, as follows:

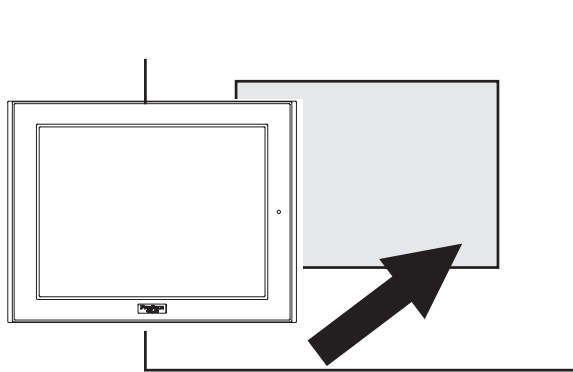

2. Insert the installation fasteners into the GLC unit's insertion slots — two slots each, at the top and bottom of the unit (4 slots total).

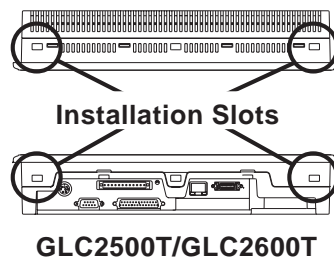
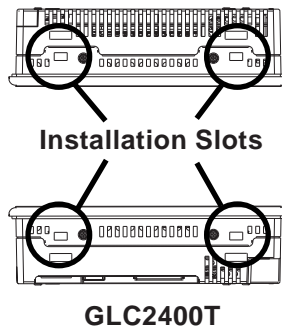

3. Insert each of the fasteners as follows.

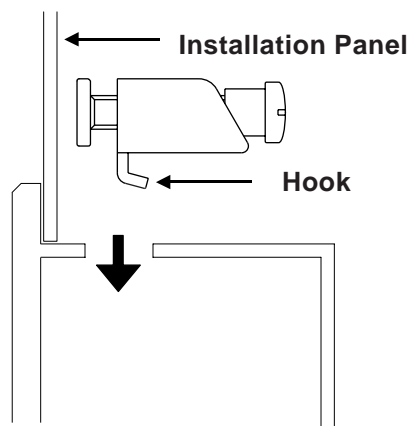

## Chapter 3 – Installation and Wiring

4. Be sure to pull the fastener back until it is flush with the rear of the attachment hole.

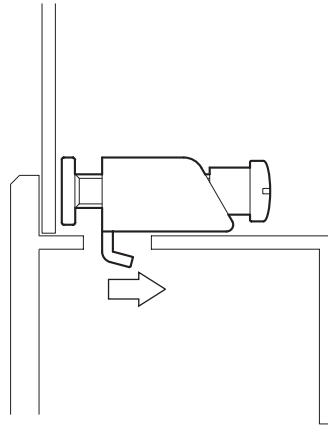

5. Use a Phillips screwdriver to tighten each fastener screw and secure the GLC in place.

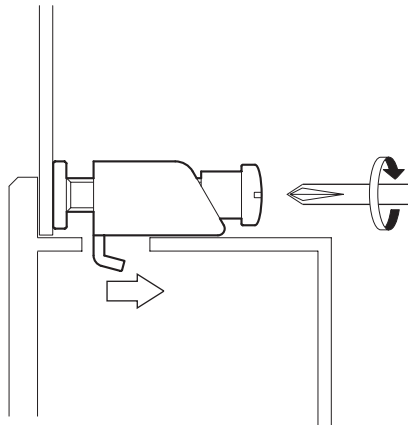

---

**A torque of only 0.5 to 0.6 N•m is sufficient to tighten these screws. Excessive force may damage the GLC unit.**

---



Depending on the installation panel's thickness, etc., the number of installation fasteners used on a GLC2600 Series can be increased to provide a higher level of moisture resistance. (The GLC2400T is limited to four (4)).



## 3.2 Wiring Cautions

### 3.2.1 Connecting the Power Cord



## WARNINGS

- To avoid an electric shock, be sure the power cord is unplugged from the power outlet when connecting the power terminals to the GLC unit.
- The GLC2400-TC41-24V, GLC2500-TC41-24V and GLC2600-TC41-24V units are designed to use only DC24V input. Any other power level can damage both the GLC and the power supply.
- The GLC2500-TC41-200V and GLC2600-TC41-200V units are designed to use only with 100 V to 240V AC input. Any other power level can damage both the GLC and the power supply.
- The GLC is not equipped with a power switch. Therefore, be sure to connect a breaker type power switch to the GLC unit's power cord.
- The FG terminal must be connected to earth, to protect against electrical shock when the unit breaks down.



- To prevent the Ring Terminals\*1 from short-circuiting when the terminal block attachment screws are loosened, use sleeve-type Ring Terminals.
- When the FG terminal is connected, be sure that the wire is grounded. Not grounding the GLC unit will result in excessive noise. Use your country's applicable standard for grounding.
- The SG and FG terminals are connected internally in the GLC unit.
- When connecting the SG line to another device, be sure that the design of the system/connection does not produce a shorting loop.



- Whenever possible, use thick wires (max. 2mm<sup>2</sup>) for power lines, and twist the exposed wire ends when connecting the Ring Terminals.
- Use the following crimp-on type Ring Terminals.

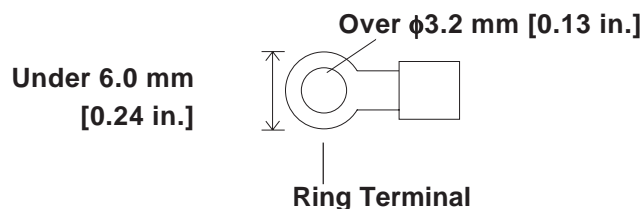

## ■ Connecting the Power Supply Lines

### ◆ GLC2500-TC41-200V, GLC2600-TC41-200V

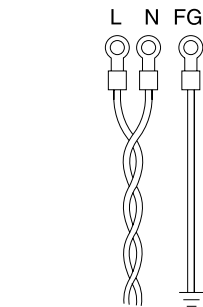
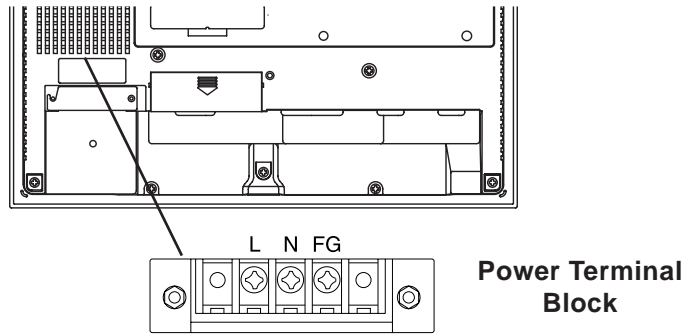

<b>L</b>	AC Input Live Line
<b>N</b>	AC Input Neutral Line
<b>FG</b>	Grounding Terminal connected to the GLC chassis.

### ◆ GLC2400-TC41-24V

### ◆ GLC2500-TC41-24V, GLC2600-TC41-24V

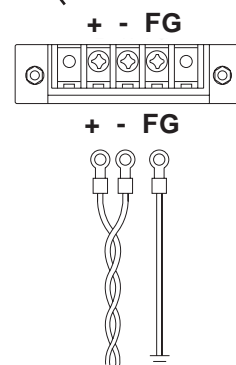
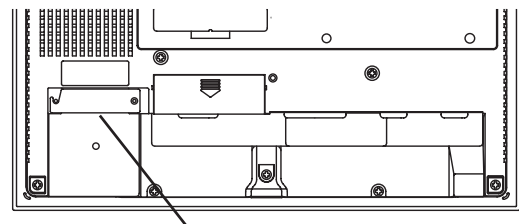
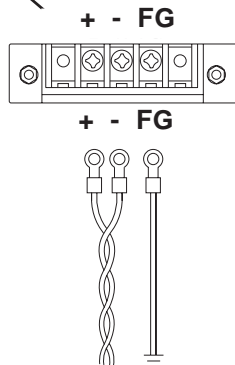
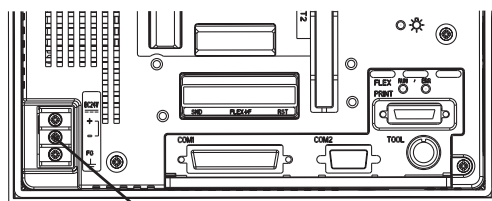

<b>+</b>	Positive electrode
<b>-</b>	Negative electrode
<b>FG</b>	Grounding Terminal connected to the GLC chassis.

## Chapter 3 – Installation and Wiring

1. Make sure that the GLC unit's power cord is not plugged in to the power supply.
2. Remove the Terminal Strip's clear plastic cover.
3. Remove the screws from the three (3) middle terminals, position the Ring Terminals (as shown above), and reattach the screws. (Check each wire to make sure the connections are correct)



- **Be sure that each Power Supply Line Ring Terminal is connected to the correct terminal.**
- **Use a torque of only 0.5 to 0.6 N•m to tighten an attachment screw.**

4. Reattach the Terminal Strip's clear plastic cover.

### 3.2.2 Connecting the Power Supply

- If the supplied voltage exceeds the GLC unit's range, connect a voltage transformer. **Reference Chapter 2 Specifications for the allowable voltage range.**
- For between the line and ground, select a power supply that is low in noise. If there is an excess amount of noise, connect a noise reducing transformer.

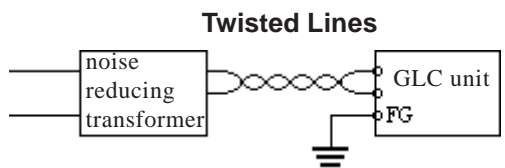
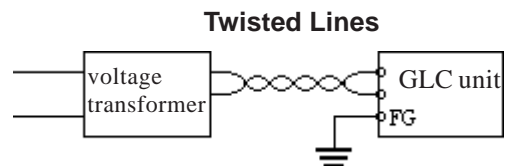

**Use Voltage and Noise Reducing transformers with capacities exceeding 100VA.**

- When supplying power to the GLC unit, separate the input/output and operation unit lines, as shown.
- To increase the noise resistance quality of the power cable, twist each power wire before attaching the Ring Terminal.

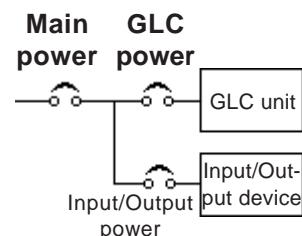

## Chapter 3 – Installation and Wiring

- The power supply cable must not be bundled or positioned close to main circuit lines (high voltage, high current), or input/output signal lines.
- Connect a lightning surge absorber, as shown in the diagram, to deal with power surges.
- To avoid excess noise, make the power cable as short as possible.

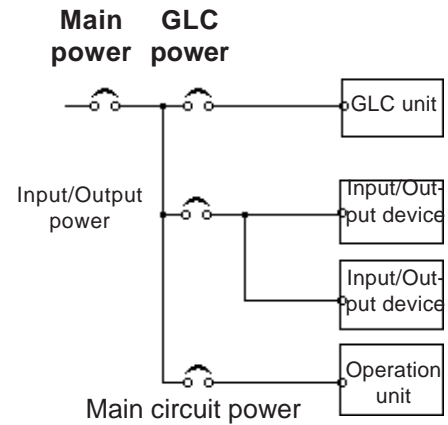

- **Ground the surge absorber (E1) separately from the GLC unit (E2).**
- **Select a surge absorber with a maximum circuit voltage that is greater than that of the power supply's peak voltage.**

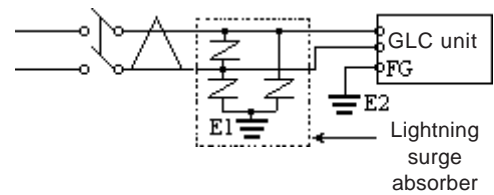

## Chapter 3 – Installation and Wiring

### 3.2.3 Grounding



## CAUTION

**Do NOT use common grounding, since it can lead to an accident or machine breakdown.**

Connect the FG terminal found on the back of the GLC to an exclusive ground (diagram A).

(A) Exclusive Grounding (BEST)

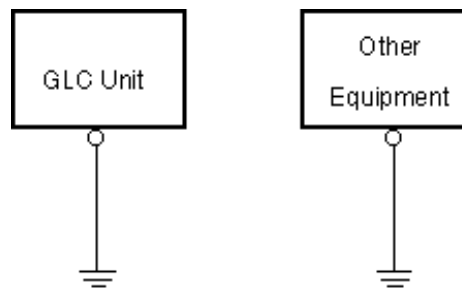

- Make sure that the grounding resistance is less than 100Ω.
- The SG and FG terminals are connected internally in the GLC unit.
- When connecting the SG line to another device, be sure that the design of the system/connection does not produce a shorting loop.
- The grounding wire should have a cross-sectional area of at least 2 mm<sup>2</sup>. Create the grounding point as close to the GLC unit as possible, and keep the wire as short as possible. Replace thin wire with a thicker wire, and place it in a duct.

If exclusive grounding is not possible, use a common connection point (diagram B).

(B) Common Grounding (OK)

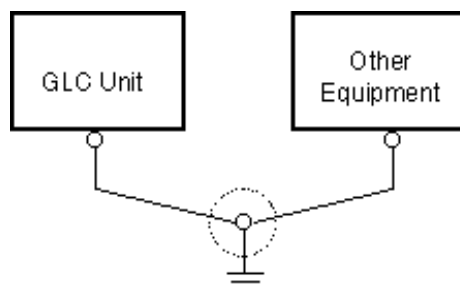

(C) Common Grounding (Not OK)

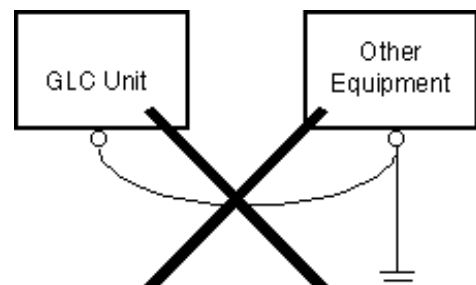

If the equipment does not function properly when grounded, disconnect the ground wire from the FG terminal.

### 3.2.4 I/O Signal Line Cautions

---

To help prevent noise and interference problems, separate all communication lines from power lines by placing them in a separate duct.

Duct for Communication Lines

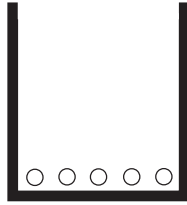

Duct for Power Lines

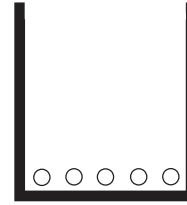

If different wires must be placed in the same duct, separate them with an earthed/grounded divider.

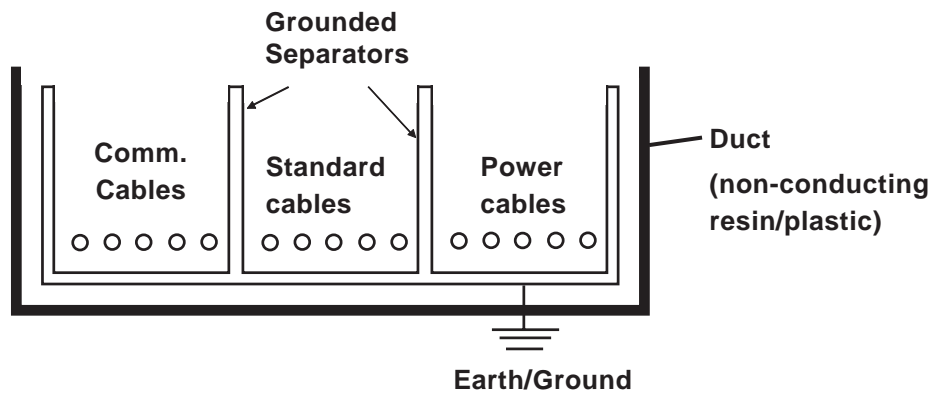

**Note:**

When you are unable to separate the cables as shown above, be sure to use shielded cable and create a ground from the shield line.

### 3.2.5 Installation Cautions

---

A problem in the external power supply or a GLC unit failure can lead to operation failures.

Since these types of failures can affect the entire system, as a preventive measure, be sure to set up a protection circuit (such as an Emergency Stop, Protection Network, Interlock, or System Design Circuit) in areas where potential failures may occur.

Examples of protection circuits that ensure the system's reliability include the following:

## Chapter 3 – Installation and Wiring

### ■ Failsafe Electrical Circuits

When designing failsafe circuits, be aware of possible malfunctions resulting from differences in the startup times of the control device connected to GLC output unit (especially the DC power supply), the GLC unit's system, and the program. When using a remote I/O, create a logic program to check the terminal status.

For example, connect an electrical voltage relay coil to the GLC output unit power supply circuit and to any connected control devices' power circuit, then connect their contacts to the GLC input unit. Design the circuit so that it checks for an ON signal from the electrical voltage relay using a logic program, then executes the ladder program of the control device connected to the GLC output unit.

### ■ Input Voltage

Be sure to supply AC100V to AC240V (AC85V to AC265V) power to the GLC2500-TC41-200V and GLC2600-TC41-200V units.

Be sure to supply DC24V (DC19.2V to DC28.8V) power to the GLC2400-TC41V, GLC2500-TC41V, and GLC2600-TC41V units.

### ■ Power Interruption

When the GLC2500-TC41-200V or GLC2600-TC41-200V unit's rated voltage drops for 20ms or more, it will enter "Power Cut" status.

When the GLC2400-TC41-24V, GLC2500-TC41-24V or GLC2600-TC41-24V unit's rated voltage drops for 10ms or more, it will enter "Power Cut" status.

For example, if the power is cut while an FMOV command is sending data in 100-word units, command execution will stop.

When designing the program, allow for the possibility of a power interruption.

### ■ Emergency Stop Circuit

Do NOT send an Emergency Stop signal to the GLC, and do NOT use the GLC unit's internal software to process an Emergency Stop signal.

As shown below, be sure to create the Emergency Stop circuit outside the GLC.

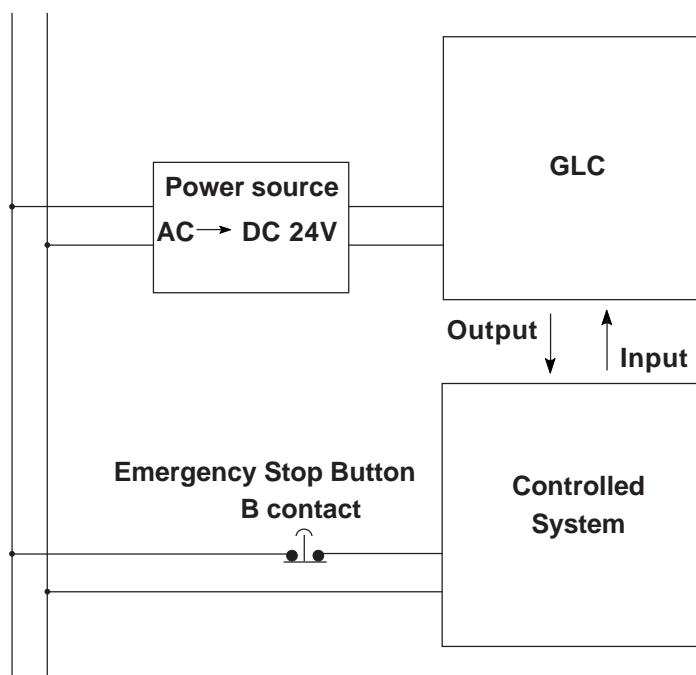

## ■ Interlock Circuit 1

Create an interlock circuit outside the GLC (below), to control a motor's forward/reverse rotation circuit using a GLC or PLC connection.

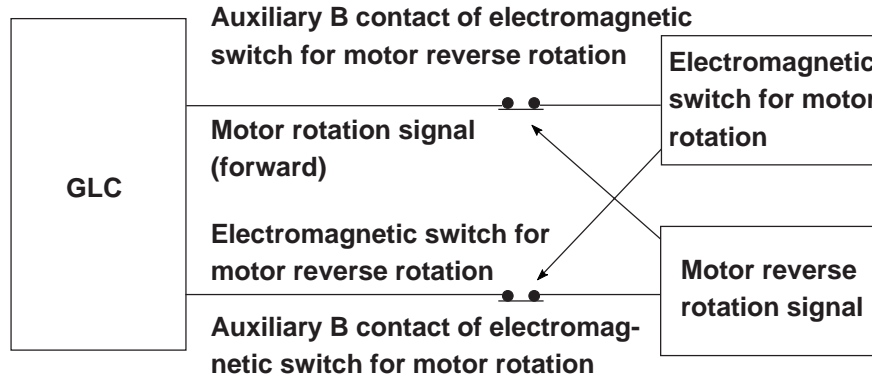

**Note:**

After the GLC runs the program, the timing of the ON/OFF signals to an output device is carried out simultaneously.

For example, an electromagnetic switch for forward and reverse motor rotation could be turned ON and OFF at the same time. Therefore, when the main contacts for the power circuits of both the forward and the reverse motor rotation are turned ON and OFF at the same time, an R Phase and a T Phase short circuit may occur. Use the above interlock, or a mechanical interlock equipped with an electromagnetic switch, when designing a forward/reverse rotation circuit.

## ■ Interlock Circuit 2

If there is a possibility that a GLC failure could cause an accident, use an external hardware device to include a failsafe element in the design of the interlock circuit. For example, if the system first needs to stop the Travel Motor whenever the Unit Travel Limit Switch is activated, include the Unit Travel Limit Switch in the GLC input. The following circuit uses a hardware method to ensure that the Travel Motor is stopped.

This applies to hardware. Do NOT rely on software to process the interlock design.

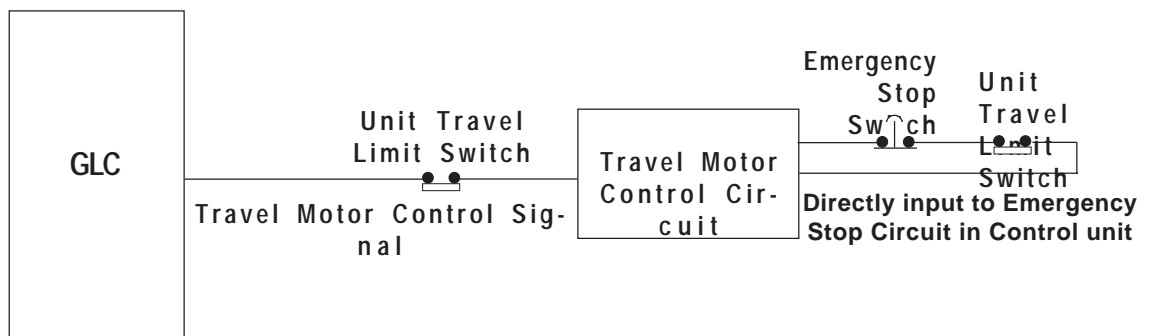



### 3.3 Tool Connector

A Data Transfer Cable, Memory Loader, or a Bar-Code Reader can be attached to the GLC unit's Tool Connector.



## WARNING

To prevent an electrical shock, unplug the GLC unit's power cord from the main power supply prior to attaching or detaching any connectors to or from the GLC.

Rear Face  
GLC-2400T

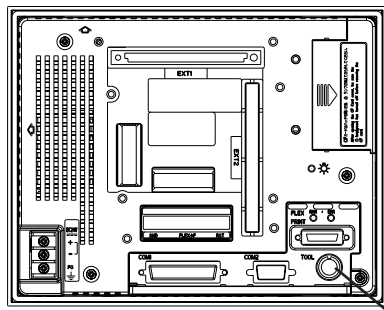

Rear Face  
GLC-2500T/GLC-2600T

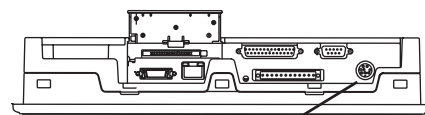

Tool Connector



When the Bar Code Reader uses a separate power supply:

- Turn the Bar Code Reader ON before turning the GLC ON.
- Turn the GLC OFF before turning the Bar Code Reader OFF.

### 3.4 Ethernet Cable Connector

The GLC Ethernet interface is IEEE802.3 compliant, and transmits data at 10 Mbps. Your Ethernet connector can be found on the GLC, as follows.

Side Face  
GLC-2400T

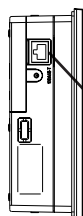

Side Face  
GLC-2500T/GLC-2600T

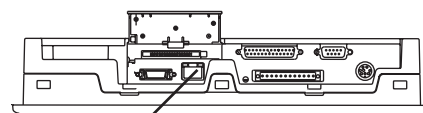

Ethernet Interface  
(RJ-45 Connector)



- Note:** • It is strongly recommended that your Ethernet network is installed by a trained engineer.
- 1:1 connections using a cross cable may not be possible depending on the type of personal computer and network card you are using. Make sure to use a hub for connection.

## 3.5 CF Card Installation and Removal



### CAUTIONS

When using the GLC Unit and a CF Card, follow these precautions:

- Prior to inserting or removing a CF Card, turn the GLC unit's CF Card ACCESS switch OFF, and confirm that the ACCESS lamp is not lit, to prevent damage to or loss of the CF Card's internal data.
- When a CF Card is being accessed, NEVER:
  - turn OFF or reset the GLC
  - insert or remove the CF Card

Prior to performing these operations, create and use a special GLC application screen that will prevent access to the CF Card.

**Reference** Refer to the *GP-PRO/PB III for Windows Tag Reference Manual* (included with the screen creation software package).

- Prior to inserting a CF Card, familiarize yourself with the CF Card's front-face and rear-face orientation, as well as with the CF Card connector's position. To prevent damage to either the CF Card's internal data or the GLC unit, the CF Card must be correctly positioned when it is inserted into the multi-unit.
- Use only CF Cards manufactured by the Digital Electronics Corporation. GLC unit performance cannot be guaranteed when another manufacturer's CF Card is used.
- Lost GLC data cannot be recovered. Since accidental data loss can occur at any time, be sure to back up all GLC screen and CF Card data regularly.
- Be sure to follow the instructions below to prevent the malfunction of a CF Card or the destruction of a CF Card's internal data:
  - DO NOT bend the CF Card.
  - DO NOT drop or strike the CF Card against another object.
  - Keep the CF Card dry.
  - DO NOT touch the CF Card connectors.
  - DO NOT disassemble or modify the CF Card.

## Chapter 3 – Installation and Wiring

### ■ Inserting the CF Card

Use the following steps to insert the CF Card in the GLC.

(The illustration shows a GLC2500/GLC2600 unit. The procedure, however, is the same as it is for that of a GLC2400 unit.)

1. To open, slide the CF Card Cover in the direction, as shown, and then upwards.

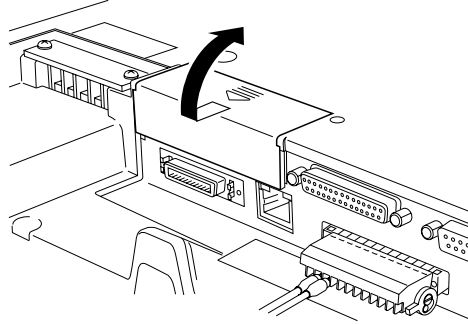

2. Insert the CF Card in the CF Card Slot, until the ejector button is pushed forward.

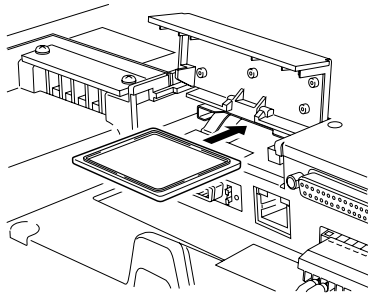

3. Close the cover.

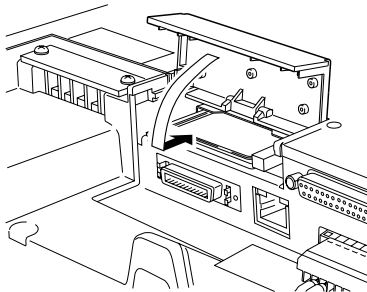

4. Confirm that the CF Card Access LED turns ON.



The GLC cannot access the CF Card if the CF Card cover is already opened. If however, the CF Card Cover is opened while the GLC is accessing the CF Card, access will not be interrupted.

### ■ Removing the CF Card

Prior to removing the CF Card, confirm that the CF Card Access LED is turned OFF. To remove the CF Card, retrace the previous “Inserting the CF Card” steps.

### 3.5.1 CF Card Handling

---

The CF Card has a data overwrite limit of approximately 100,000 times. Therefore, be sure to back up all CF Card data regularly to another storage media. (100,000 times assumes the overwriting of 500KB of data in DOS format)

Two methods are available for backing up data. After using either method (1) or method (2), use your PC to save your data to the CF Card.

**(1) If your PC is equipped with a PC Card Slot**

To view CF Card data on a personal computer, first, insert the CF Card into a CF Card

Adapter.

**(2) If your PC is NOT equipped with a PC Card slot**

Use a commercially available PC Card Reader, or a CF Card Reader.

### 3.6 Connecting to the Screw Lock Terminal

Use the following procedure to connect the External Reset, Flex Network, or Sound Output to the Screw Lock Terminal.

#### 3.6.1 Cable Preparation

Remove the wire's external covering and insert the center strand into the connector opening

Unit: mm [in.]

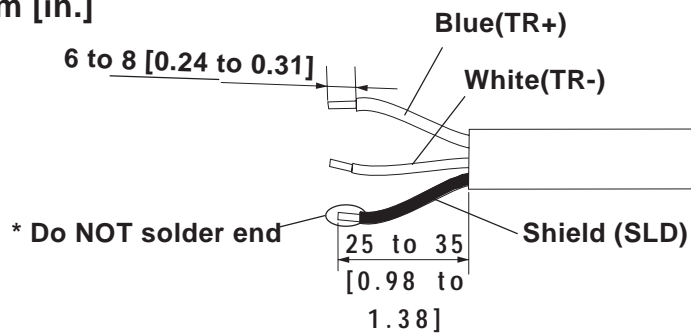

- Be sure to tape or put a plastic tube over the shield line.
- Do NOT solder the wire. Doing so could result in a bad or poor contact.

#### 3.6.2 Terminal Connection

Use the following steps to connect the speaker. (The illustration shows a GLC2500/GLC2600 unit. The procedure, however, is the same as it is for that of a GLC2400 unit.)

1. Rotate the screw lock terminal block's two (2) levers downward, as shown, and remove the screw lock terminal block.
2. Loosen the corresponding pin's set screw and insert the cable.

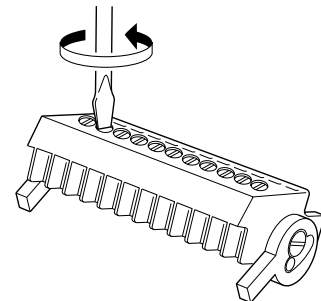
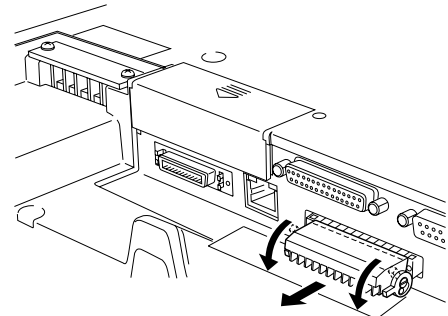

The following procedures are used when connecting the Sound Output terminals.

## Chapter 3 – Installation and Wiring

3. Make sure that each line (cable) is inserted completely.

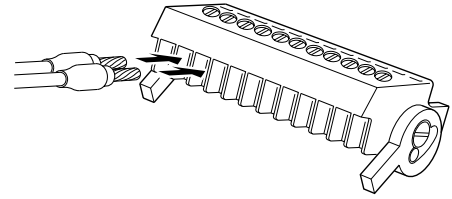

4. Retighten the two (2) set screws.

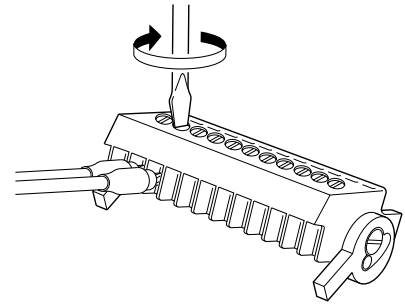

5. Reattach the screw lock terminal block to the GLC.

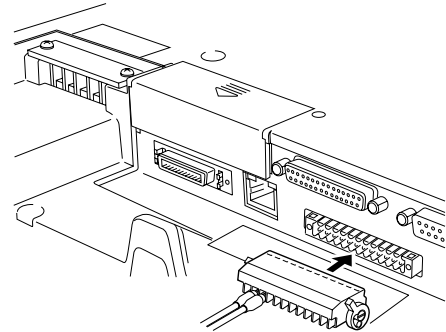

Pins used for External Reset:

Pin number	Signal Name
1	AUXCOM
2	AUXRESET

Pins used for Flex Network:

Pin number	Signal Name
3	TR+
4	TR-
5	SLD
6	TR+
7	TR-
8	SLD

Pins used for Sound Output:

Pin number	Signal Name
10	SP OUT
11	GND



**Be sure that all lines (cables) used are held securely in a cable clamp. This clamp should be located near the rear of the GLC. Do NOT use excessive force to tighten the wire set screws.**



- Use a small screwdriver (thickness 0.4 mm, tip width 2.5 mm) to tighten the set screws.
- The recommended torque for tightening the set screws is 0.2 to 0.4 N•m.
- If wire ends are not carefully twisted, strands from adjacent wires or contact with an electrode may cause a short circuit.

## Chapter 3 – Installation and Wiring

### 3.6.3 Sound Volume Adjustment

---

Use the following steps to adjust the sound volume.

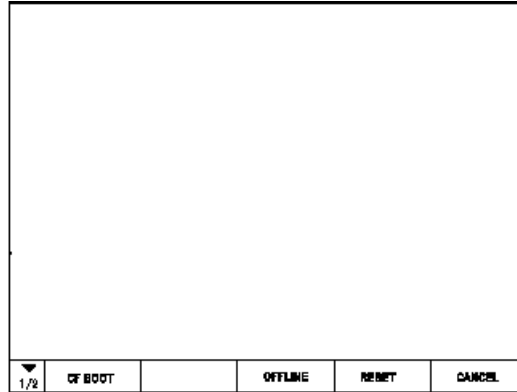

1. Call up the GLC menu bar.

**Reference**  6.4.3 – *SETUP TOUCH PANEL*

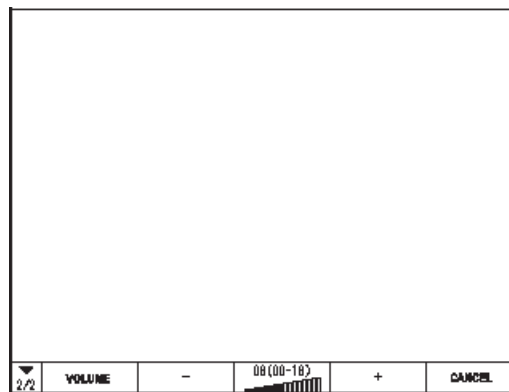

2. Touch the left-most key  to call up the next menu.



3. Touch the decrease key  or the increase key  to adjust the sound volume to the desired level.

# Chapter

## 4 Data Transfer

1. Serial Data Transfer
2. Ethernet Data Transfer
3. CF Memory Loader Tool

This chapter explains how to transfer data created with the screen creation software using one of the following three (3) methods.

- Transfer data between the GLC and your PC via the data transfer cable.
- Transfer data to the GLC via an Ethernet network.
- Transfer data between the GLC and your PC with the CF Card, using the CF Memory Loader Tool.

### 4.1 Serial Data Transfer

- Please connect it at an angle correct so as not to push it forcibly with the connector when you install the cable. The main body and the connector might break down.

#### ■ Connection of data transfer cable

#### ◆ When using data transfer cable (GPW-CB02)

The following diagram illustrates the connection between your PC and the GLC with the data transfer cable.

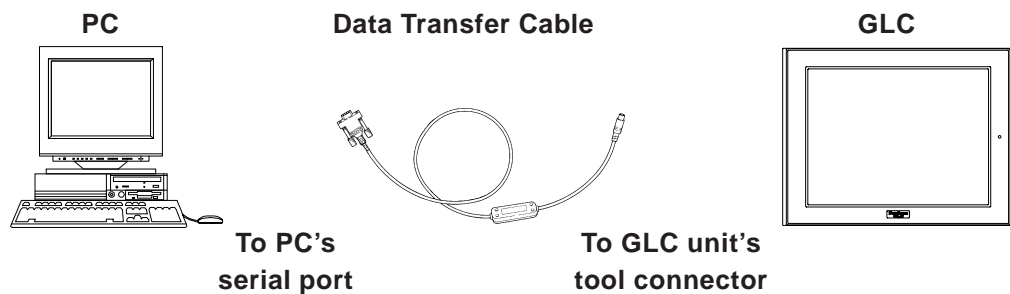

#### Note:

- Pro-face's data transfer cable (GPW-CB02) is sold separately. However, the data transfer cable package does NOT include the PC's interface conversion adapter.
- When using the PC with the Dsub 25-pin socket (female) interface, a connector conversion adapter is required. Use the straight-line type of conversion adapter.

Recommended adapters:

Arvel AA833

SANWA SUPPLY INC. D09-9F25F

- When using a PC equipped with a half-pitch, 14-pin socket interface, a conversion adapter is required.

Recommended adapter:

LOAS Co. Ltd. ZR01-024



## ◆ When using USB transfer cable (GPW-CB03)

Please install the USB connector of the USB transfer cable in the USB port of the personal computer.

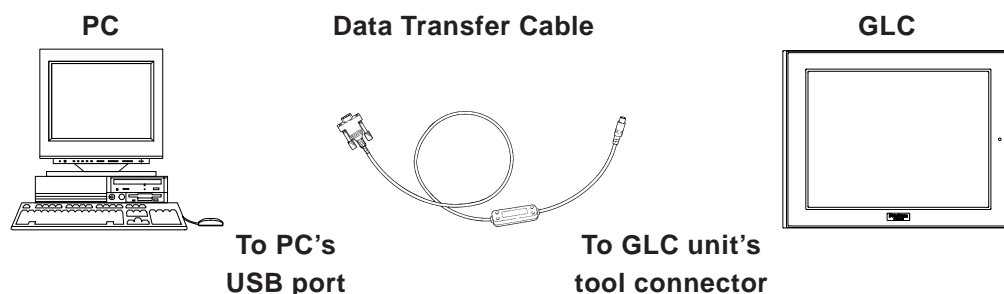

### Note:

USB transfer cable (GPW-CB03) is an optional. When USB transfer cable is used, it is necessary to install the driver by setting up the cable bundle CD. Please see the manual of USB transfer cable for details.

Transfer screen data from your PC, via the GLC screen creation software.

**Reference** For details about the GLC screen creation software, refer to **GP-PRO/PBIII for Windows Operation Manual** (included with the screen creation software).

Transfer the logic program data from your PC, via the Logic Program Development Software.

**Reference** For details about the Logic Program Development Software, refer to **Pro-Control Editor Operation Manual** (included with Pro-Control Editor).

## ■ Transferring Data to a New GLC

Connect the GLC to your PC via the data transfer cable, and then turn the GLC ON. The Initial Start Mode screen will appear on the GLC and you can transfer screen from your PC. The screen will change to the Transfer screen automatically.

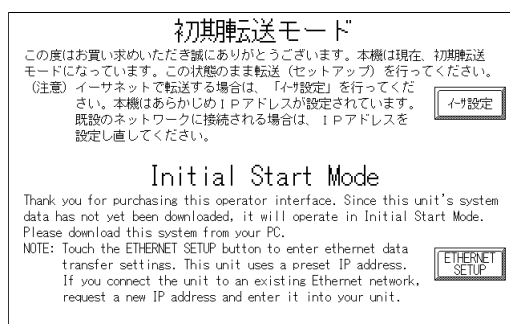

### ■ Completing Data Transfer using GLC setup\*<sup>1</sup>

When transferring screen data from the GLC screen creation software, the screen automatically switches to SCREEN DATA TRANSFER. If the screen does not switch to SCREEN DATA TRANSFER, select SCREEN DATA TRANSFER mode.

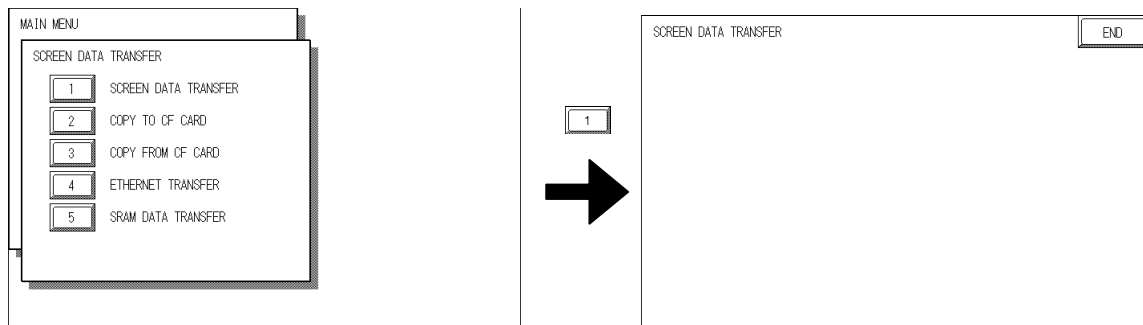

During data transfer, the SETUP TRANSFER and NOW TRANSFERRING – PLEASE WAIT messages appear. When these messages disappear, the screen data transfer is completed.

You can cancel data transfer at any time using your GLC screen creation software.

When the screen data transfer is completed, if you do not need to set up the GLC, the screen designated in INITIAL SETTINGS | SCREEN SETUP | INITIAL SCREEN FILE NO. appears, and the screen changes to operation (RUN) mode.

The Logic Program Data Transfer is available only with the GLC, which is pre-installed.

**Reference** *Pro-Control Editor Operation Manual (included with Pro-Control Editor)*



**Interrupting the screen data transfer can lead to a GLC startup error. During screen data transfer, do NOT:**

- disconnect the GLC unit's power supply
- turn off the PC
- disconnect the GLC unit's transfer cable



If the GLC screen creation software's "GP SYSTEM SETTINGS"<sup>2</sup> data is transferred to the GLC, the OFFLINE mode "INITIAL SETTINGS" data will be overwritten.

1. To "Set up the GLC" means to download both the system program and the user-specified protocol program from the GLC screen creation software to the GLC unit.
2. Some GLC Offline displays are referred to as "GP," however it is the same as "GLC" here.

### 4.2 Ethernet Data Transfer

The GLC2000 Series unit is equipped with the Ethernet I/F which allows you to set up the GLC via an Ethernet network, as well as transfer GLC screen data.



**When using the Ethernet communication protocol, you must specify the port number for the protocol as +10 or higher than the value specified in this section. Otherwise, the setup or screen data transfer via Ethernet is disabled.**

After you connect an Ethernet cable to the GLC’s Ethernet I/F, the GLC will appear on the Ethernet network.

#### ■ Transferring Data to a Completely New GLC

##### ◆ Setting Up the IP Address Manually

Touch the Ethernet Settings button on the Initial Start Mode screen.

**Reference** 6.5.4 – “ETHERNET SETUP”

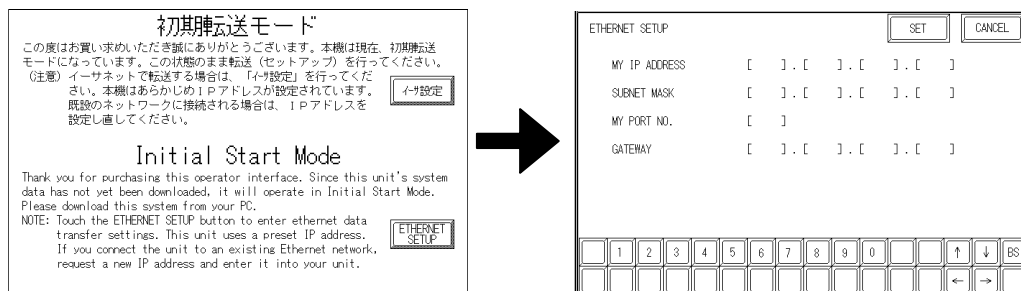

##### ◆ Setting Up the IP Address Automatically

It is not necessary to select Ethernet Settings on the Initial Start Mode screen. When the options for Ethernet Settings are not specified, they are set automatically.

If you choose to set the IP address automatically, specify the IP address of the PC in the range of “10.255.255.1” to “10.255.255.254” and the subnet mask as “255.0.0.0.”

Transfer data using the screen creation software package.

**Reference** *GP-PRO/PBIII for Windows Operation Manual (included with the screen creation software package)*

### ■ When transferring data using the GLC setup is completed

When you transfer screen creation software data from your PC to the GLC while the GLC is in RUN mode, the screen will change automatically to “Ethernet Mode.” If it does not, you will need to manually change the GLC screen to Ethernet Mode, via the following screen.

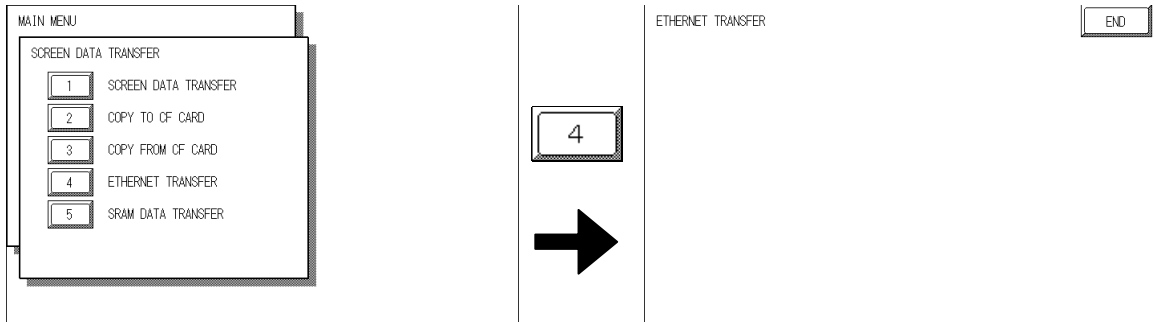

You can now transfer data from your PC’s screen creation software.

**▼Reference▲** *GP-PRO/PBIII for Windows Operation Manual (included in the screen creation software package)*

Transfer the logic program data from your PC, via the Logic Program Development Software.

**▼Reference▲** *For details about the Logic Program Development Software, refer to GP-PRO/PBIII for Windows Operation Manual (included with Pro-Control Editor).*

#### 4.2.1 Checking the IP Address

---

Use the following procedure to check the IP Address assigned to the GLC and some considerations/precautions.

1. Display the menu bar. For instructions on how to display the menu bar, **▼Reference▲** 6.4.3 – “SET UP TOUCH PANEL”
2. Click on the left-side 1/3 cell of the menu bar to display the next menu.

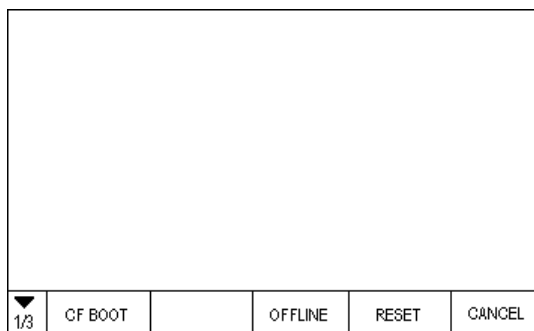

## Chapter 4 – Transfer Screen Data

3. Next, click on the 2/3 cell to display the following menu.

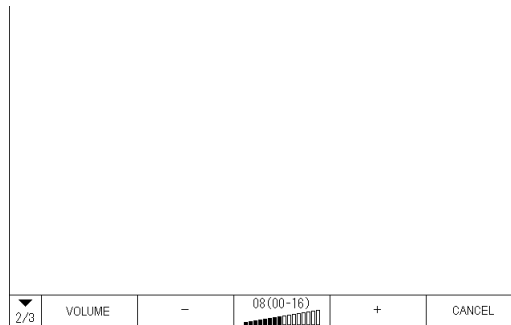

4. The IP Address assigned to the GLC will appear in the menu bar.

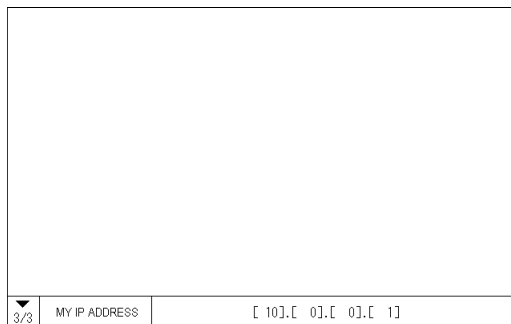

**Note:**

IP Address will not be reflected unless GLC was reset or power cord was re-connected. After changing “Ethernet Setup” settings, the GLC must then be reset or power cord must be re-connected.

### 4.3 CF Memory Loader Tool

The GLC unit allows you to transfer screen data between your PC and the GLC and to upload internal GLC data to its CF Card using the CF Memory Loader Tool.



**Note:**

- You need to transfer the CF Memory Loader Tool to the CF Card prior to using the CF Memory Loader Tool.  
**Reference** *GP-PRO/PBIII for Windows Operation Manual*
- The combination of the CF Memory Loader Tool and Backup Data often requires at least 8MB of CF Card memory. Use Digital’s CF Card “GP077-CF20 (16MB)” or “GP077-CF30 (32MB).”

#### ■ Starting the CF Memory Loader Tool

There are two methods for starting this program via the CF Card.

##### 1. Menu Bar: Using the GLC unit’s [CF BOOT] menu

Insert the CF Card with the CF Memory Loader Tool saved into the GLC and touch the menu screen’s CF BOOT selection. The GLC will be reset, and after it restarts, the CF card’s CF Memory Loader Tool will start.

**Reference** *For information about displaying the Menu bar, see Section 6.4.3 – “SET UP TOUCH PANEL.”*

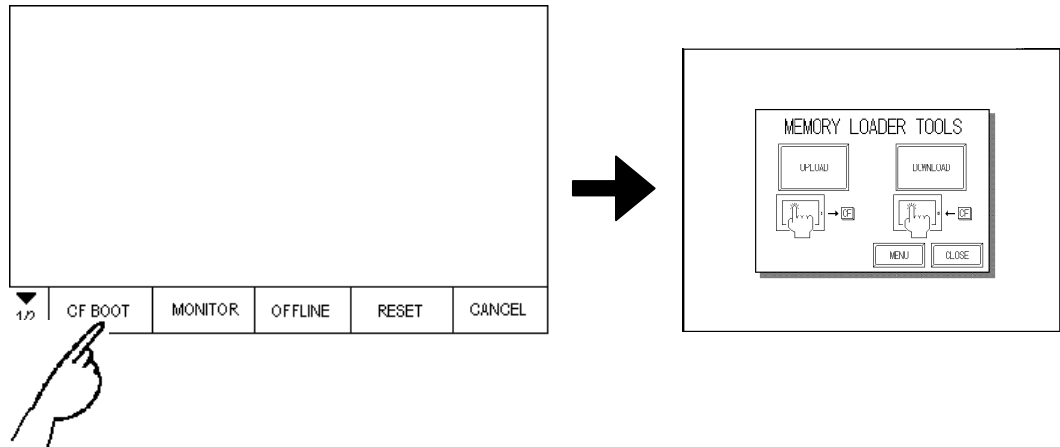

### 2. GLC Dip Switches: Forced Start via GLC Dip Switches

You can also use the Dip Switches on the rear of the GLC, next to the CF Card Slot. If you turn ON Dip Switch No.1 (raise it) and then connect the GLC unit's power cord, the "CF Memory Loader Tool will automatically start.

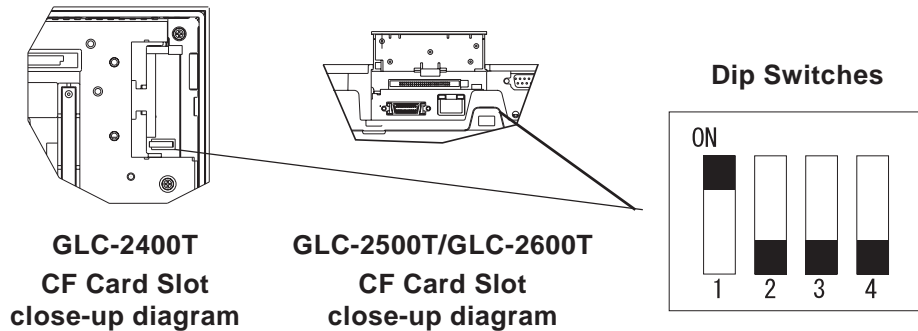

**Note:**

When you finish using the CF Memory Loader Tool, turn this dip switch OFF.

### 4.3.1 Data Upload and Download

When the Memory Loader Tool program starts, the following screen will appear.

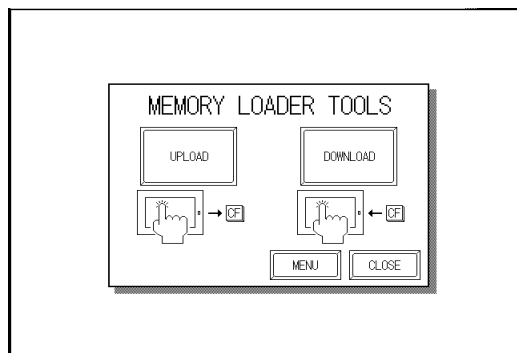

## Chapter 4 – Transfer Screen Data

### ■ UPLOAD (From GLC to CF Card)

This feature is for saving all GLC internal data (i.e. system program, communication protocol, expansion program, screen data and Backup SRAM data) in the CF Card as backup data.

To start data upload, enter the password you designated in the screen creation software's "Transfer" screen, and then touch the START key. If you have not designated a password however, touch the START key.



**When UPLOAD is performed, the CF Card's current Backup Data will be completely overwritten.**

### ■ DOWNLOAD (From CF Card to GLC)

This feature is used for writing CF Card backup data to the GLC unit's Internal SRAM Memory.

To start data download, enter the password you designated in the screen creation software's "Transfer" screen, and touch the START key. If you have not designated a password, touch the START key.



**When DOWNLOAD is performed, the GLC unit's Internal Memory data (such as system program, communication protocol, expansion program, screen data and Backup SRAM data) will be completely overwritten.**

# Chapter 5 OFFLINE Mode

1. Entering OFFLINE Mode
2. OFFLINE Mode Main Menu
3. INITIALIZATION
4. SELF-DIAGNOSIS

OFFLINE Mode provides access to the GLC unit's Initialize menu, Self-Diagnosis menu, and other GLC features. You will need to change the GLC to OFFLINE mode before you can use any of these features.



**OFFLINE mode is unavailable in a new GLC until the necessary System data has been transferred from the screen creation software on your PC. To transfer system data, the PLC unit's power cord must be plugged in. When you transfer screen data from your PC to the GLC, the GLC unit's System data is also automatically sent.**

**Reference** For information about transferring data to the GLC, see *Chapter 4 – Data Transfer*, or refer to the *GLC-PRO/PBIII for Windows Operation Manual* (included with the screen creation software).

## 5.1 Entering OFFLINE Mode

To INITIALIZE your GLC or to perform a SELF-DIAGNOSIS, you must first switch the GLC to OFFLINE mode. This can be done using either of two methods; immediately after plugging in the GLC unit's power cord, or by using the Forced Reset feature.



**Be aware that when changing a Logic Program from RUN to OFFLINE mode, regardless of the current output hold setting, the GLC unit's and the I/O signals' processes are as follows:**

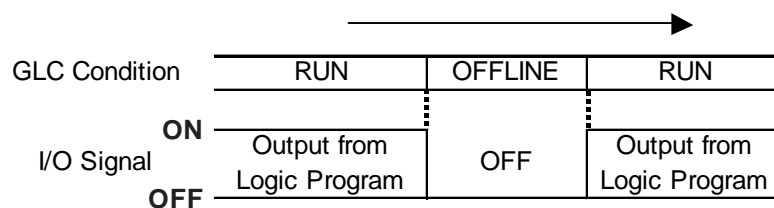

When using the RESET command, the timing of the GLC unit's I/O signal OFF timing is not fixed and can vary.



# Chapter 5 – OFFLINE Mode

## 5.1.1 After Plugging in the Power Cord

Touch the top-left corner of the GLC screen within 10 seconds after plugging in the GLC unit's power cord, and the GLC will change to OFFLINE mode.



Up to 10 seconds can elapse before the OFFLINE mode appears. During this time, the GLC unit's logic program can enter RUN mode. Once OFFLINE mode appears, be aware that all the GLC unit's I/O signals will be reset.

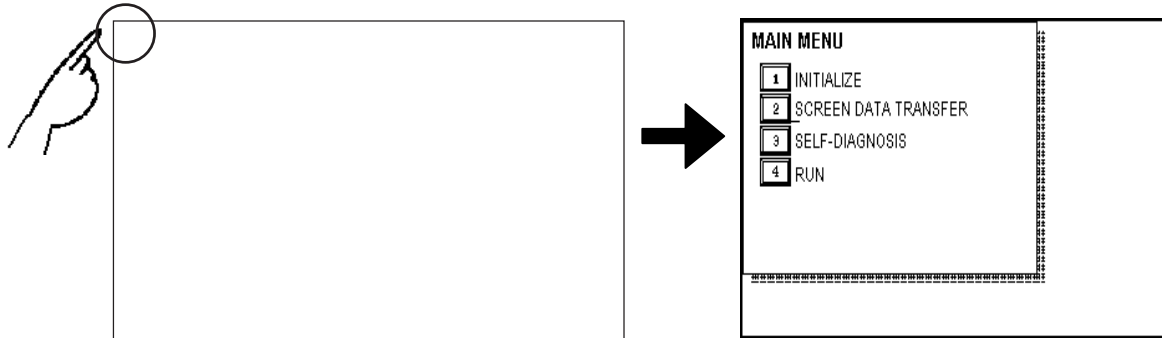

## 5.1.2 From the Menu Bar

From the GLC unit's menu bar, touch OFFLINE, and the Main Menu appears.

**Reference** To call up the Menu Bar, see *Section 6.4.3 – SET UP TOUCH PANEL; FORCED RESET.*

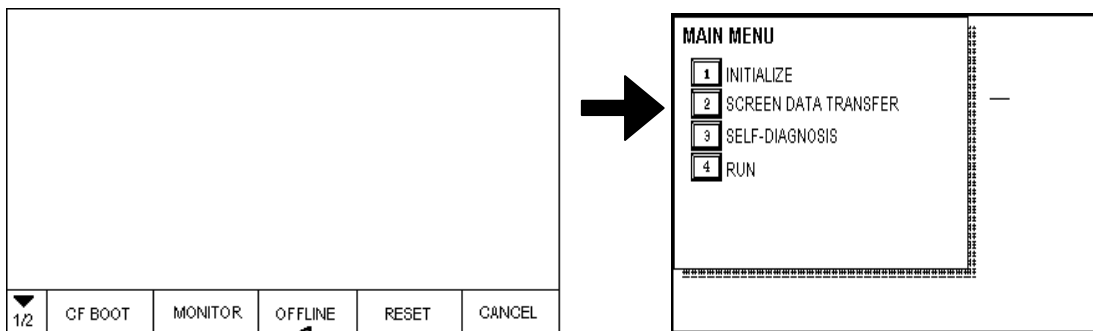

If your GLC unit includes the Device Monitor feature, the MONITOR button will be included on the menu bar.

**Reference** *GP-PRO/PBIII for Windows Device/PLC Connection Manual (included with the screen creation software), Appendix 3 - Device Monitor*

If you try to enter a Password in the INITIALIZE | SET UP SYSTEM area before entering OFFLINE mode, the following screen appears:

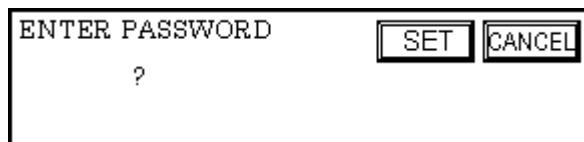

Enter the Password, then touch SET to enter OFFLINE mode.

**Reference** *For more information about Passwords, see Section 6.3.1 – “SYSTEM SETUP.”*

*For information about Entering Password Numbers, see Section 5.3 – “INITIALIZATION.”*

## 5.2 OFFLINE Mode Main Menu

---

The Main Menu contains the following menu items: INITIALIZE, SCREEN DATA TRANSFER, SELF-DIAGNOSIS, and RUN.

The settings for each menu item, below, must match the corresponding PLC, for the GLC to communicate properly.

Entering OFFLINE mode calls up the following screen.

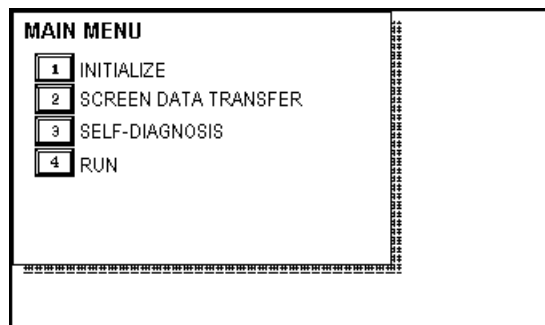

Select the desired menu item by touching the corresponding option.

Each Main Menu item is used as follows:

### INITIALIZE

Setup items control the GLC unit.

### SCREEN DATA TRANSFER

Transfers screen data between the screen creation software and the GLC.

### SELF-DIAGNOSIS

Checks to see if there are any problems with the GLC System or Interface (I/F).

### RUN

Starts GLC operation.

**Reference** *For more information about INITIALIZE, see Chapter 6 – “Initializing the GLC.”*

*For more information about TRANSFER SCREEN DATA, refer to Chapter 4 – “Data Transfer” or the GP-PRO/PBIII for Windows Operation Manual (included with the screen creation software).*

*For more information about the SELF-DIAGNOSIS and RUN features, see Chapter 7 – “Run Mode and Errors.”*

## 5.3 INITIALIZATION

### ■ Selecting Menu and Setting Items

Touch a menu item to select that menu; touch a setting item to select its input field.

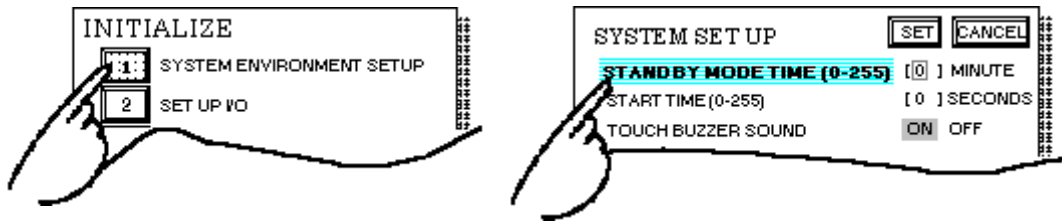

### ■ Entering Numbers

After selecting an input field, touch the numeric touch keys located at the bottom of the screen to enter the value of the selected item. After entering each input field's numeric value, touch the [SET] key to register the value.

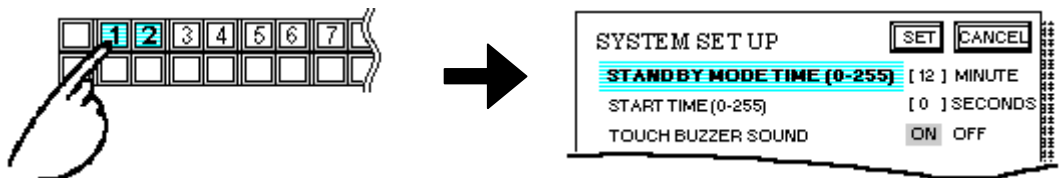

### ■ Selecting Setup Conditions

After selecting a menu item, touch the setting option to highlight the item, then touch the setting area to set the condition for that item.

In this example, touching the ON/OFF area toggles the TOUCH BUZZER SOUND setting, which is set to OFF, and then switched to ON.

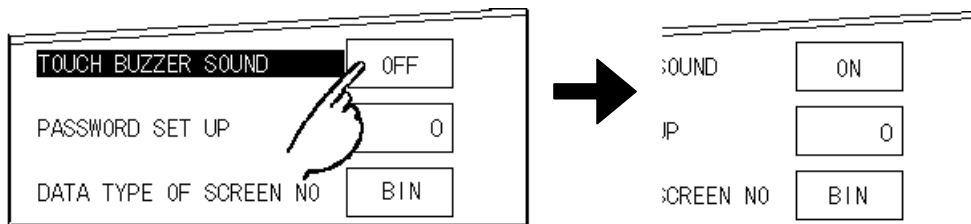

### ■ After Entering All Setting Data

Touch the top-left [SET] key to write the setup data to the Internal FEPROM.



After entering the Setup data, do NOT touch the screen until the previous menu reappears. Writing the Setup conditions to the Internal FEPROM is a process that requires a short period of time to complete.

Touch [CANCEL] to cancel the setup, exit the screen without saving the changes, and return to the previous menu.

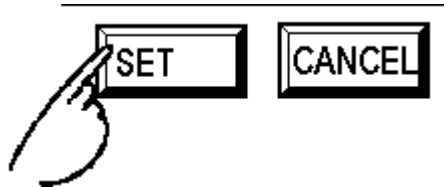

### ■ Returning to a Previous Screen

Touch the tab to call up the desired menu.

For example, to return to the MAIN MENU from the SYS. ENVIRONMENT screen, touch the MAIN MENU tab.

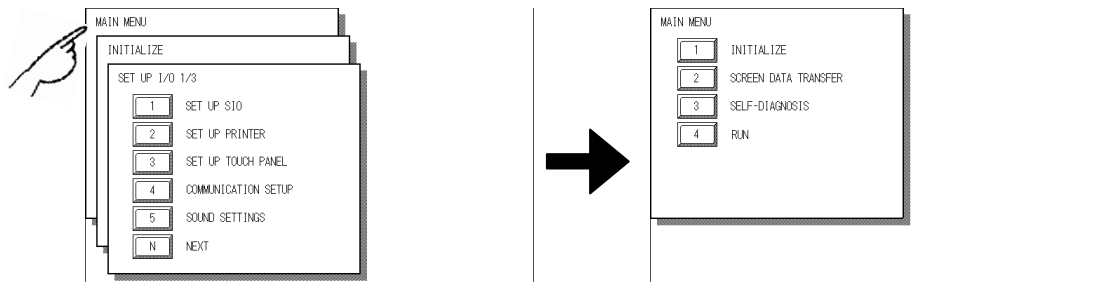

## 5.4 SELF-DIAGNOSIS

---

### ■ Selecting a Sub-Menu

Touch the desired menu item and the corresponding sub-menu appears.

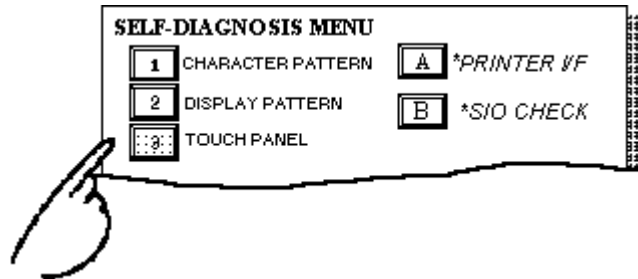

### ■ Using the [CONFIRM], [START], and [CANCEL] Keys

After selecting the Self Diagnosis item, the [CONFIRM], [START], and [CANCEL] keys may appear at different times at the top of the screen.

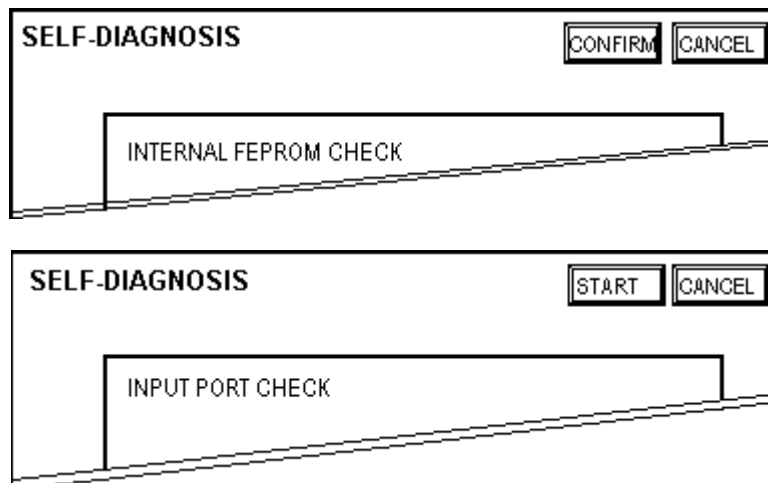

#### [CONFIRM] Key

Touch the [CONFIRM] key to inform the GLC that you have completed all steps required to run the SELF-DIAGNOSIS. All steps will be shown in the GLC unit's message dialogs.

#### [START] Key

Touch the [START] key to start the Self-Diagnosis test.

#### [CANCEL] Key

Touch the [CANCEL] key to cancel the Self-Diagnosis test and return to the SELF-DIAGNOSIS menu.

■ **Returning to the SELF-DIAGNOSIS Menu**

After performing the Self-Diagnosis check, OK is displayed. Touch once anywhere on the display screen to return to the SELF-DIAGNOSIS MENU.

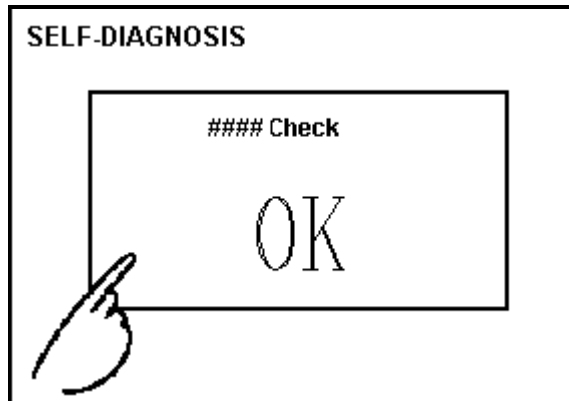

If an Error Message displays, press the bottom-left corners of the panel [1], and then touch the bottom-right corner of the panel [2] to return to the SELF-DIAGNOSIS MENU.

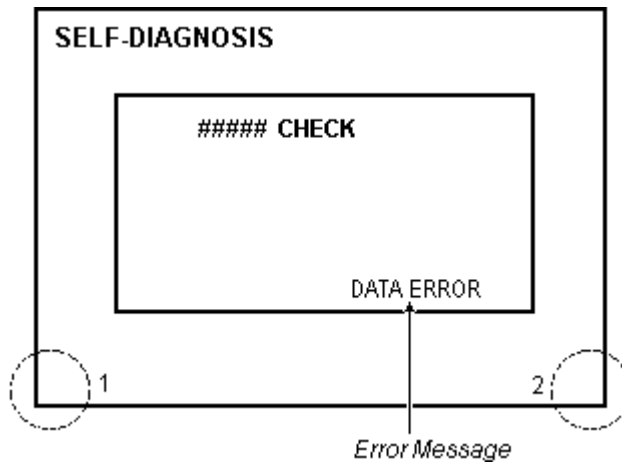

■ **Returning to the Main Menu**

Touch the RETURN key to return to the Main Menu screen.

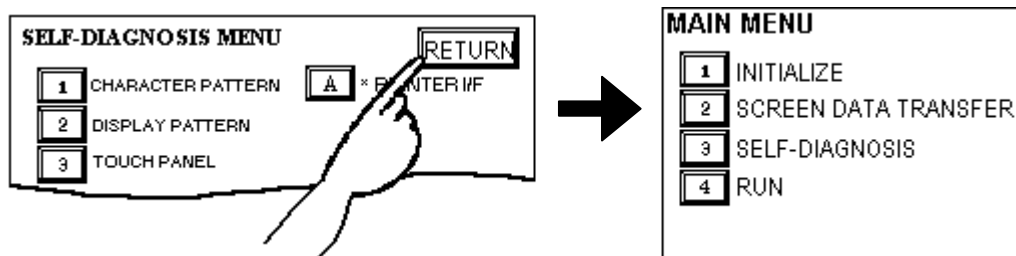

*Memo*

# Chapter

## 6 Initializing the GLC

- |                             |                               |
|-----------------------------|-------------------------------|
| 1. Initialization Screen    | 5. PLC SETUP                  |
| 2. Initialization Items     | 6. INITIALIZE INTERNAL MEMORY |
| 3. SYSTEM ENVIRONMENT SETUP | 7. SET UP TIME                |
| 4. SET UP I/O               | 8. SET UP SCREEN              |

### 6.1 Initialization Screen

---

To change your GLC unit's general operation settings, use the GLC unit's OFFLINE mode to access the items in the MAIN MENU | INITIALIZE option.

This chapter explains each of the OFFLINE mode's INITIALIZE items. However, there are two (2) types of INITIALIZE settings, those for the **1:1** connection and those for the **n:1** (multi-link) connection\*<sup>1</sup>.

The **n:1** mark appears on original menu items related to n:1 multi-link connection items. If there is no mark, the menu item is common to both 1:1 and n:1 connections.

**1:1** A single (1) GLC is connected with a single (1) PLC.

**n:1** Multiple GLCs are connected with a single PLC. The GLCs successively pass a *PLC Access Token* (exclusive PLC interaction key) among themselves to designate which unit can communicate with the PLC.



#### Note:

- If you transfer the GLC unit's system file data to the GLC via your screen design software<sup>2</sup>, the GLC operates using that data. If the GLC System file has been correctly set up and transferred, then setting up the INITIALIZE items is unnecessary.

**Reference** For more information about GLC System files, refer to the *Operation Manual, Section 1.1.2 – “Screen Types”* (included with screen creation software).

- In instances where “GP” is displayed on the GLC unit's Offline screen, the term “GLC” can be substituted.

---

1. PLCs that support the **n:1** (multi-link) connection are limited.

**Reference** Refer to the *Device/PLC Connection Manual* (included with the screen creation software).

2. Refer to the GLC screen creation software's “SYSTEM SETTINGS” area.

---



## 6.2 Initialization Items

This chapter explains the contents of the Initialize setup items listed below.

**Reference** For information about screen operations and numeric input, see *Chapter 5 – “OFFLINE Mode.”*

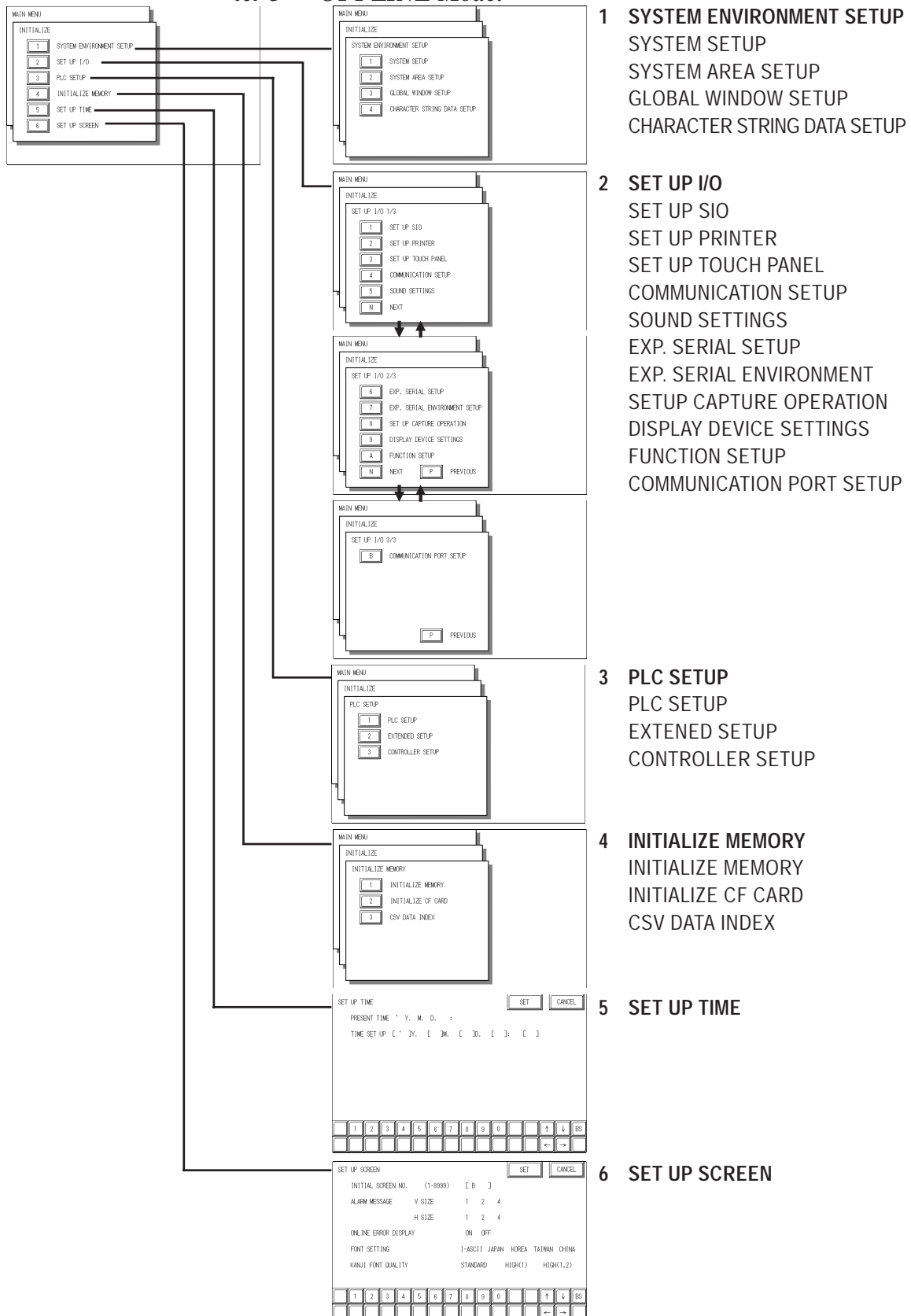

1. Depending on the PLC type selected, the screens that appear in your GLC unit's screen creation software will vary.

## 6.3 System Environment Setup

Adjustments to the GLC operation environment are made within the setup screens contained in the SYSTEM ENVIRONMENT SETUP menu. Screens include the SYSTEM SETUP, SYSTEM DATA AREA, GLOBAL WINDOW SETUP, and CHARACTER STRING DATA SETUP screens.

### 6.3.1 SYSTEM SETUP

SYSTEM SETUP		SET	CANCEL
STAND BY MODE TIME (0-255)	[ ]	MINUTE	
START TIME (0-255)	[ ]	SECOND	
TOUCH BUZZER SOUND	ON	OFF	
BUZZER TERMINAL OUTPUT	ON	OFF	
PASSWORD (0-9999)	[ ]		
DATA TYPE OF SCREEN NO.	BIN	BCD	

#### STAND-BY MODE TIME (0-255)

To protect the GLC unit's display screen, a screen saver function automatically turns the unit's backlight(s) OFF when no operations have occurred within a specified period of time. No screen saver will be used when "0" is entered in this field.

When the SYSTEM DATA AREA's SCREEN DISPLAY OFF\*1 data is set to **0000h**, the GLC unit's current display data will clear if the following operations are not performed within the user's specified period of time:

- Change Screen
- Alarm Messages (scrolling display)
- Error Messages (Except for 2Way Error)
- Menu Bar (for forced reset) display
- Touch Screen
- Japanese (FEP) System window

#### START TIME (0-255)

Use this setting item to specify the GLC unit's startup time — or to adjust the powering-up sequence — so that the GLC starts up *after* the PLCs start.

#### TOUCH BUZZER SOUND

This setting item indicates, with a buzzing sound, that the GLC has been touched.

#### BUZZER TERMINAL OUTPUT

This feature is not available in the GLC2000 Series, and therefore is disabled.

1. When using the Direct Access format, the object address becomes LS0009. When using the Memory Link format, the object address becomes +12. (Only when all items are set within the System Data Area.)

**Reference** *GP-PRO/PBIII for Windows Device/PLC Connection Manual*  
(included with the screen creation software)

## Chapter 6 – Initializing the GLC

### PASSWORD SETUP

The password setting item is used when the GLC switches to the Initialize Memory or Initialize (OFFLINE mode) screens. The password — a number between **0** and **9999** — is a security feature within the OFFLINE mode, to protect the GLC settings. If you do not wish to use this feature, enter the default value, “**0.**”

### DATA TYPE OF SCREEN NO.

This setting specifies whether BIN or BCD format numbers are used when making screen changes. Screen numbers **1** to **8999** are available for binary format. Screen numbers **1** to **1999** are available for BCD format.

### 6.3.2 SYSTEM AREA SETUP

The PLC contains and uses the System Data Area to control its GLC-related data. Different types of devices can be set up in the System Data Area, depending on the PLC type.

**When the GLC uses Memory Link format, this setting is unnecessary.**

**Reference** *PLC Connection Manual* (included with screen creation software)

Touch the number for the item desired. The item will change to reverse video, to show it has been selected.

SYSTEM AREA SETUP		CONFIRM	CANCEL
1	CURRENT SCREEN NO. (1 WORD)	8	CLOCK DATA (SET) (4 WORDS)
2	ERROR STATUS (1 WORD)	9	CONTROL (1 WORD)
3	CLOCK DATA (CURRENT) (4 WORDS)	A	RESERVED (1 WORD)
4	STATUS (1 WORD)	B	WINDOW CONTROL (1 WORD)
5	RESERVED (1 WORD)	C	WINDOW REG. NO. (1 WORD)
6	CHANGE SCREEN NO. (1 WORD)	D	WINDOW LOCATION (2 WORDS)
7	DISPLAY ON/OFF (1 WORD)	SYSTEM AREA SIZE: WORD(S)	

(Item numbers displayed in reverse mode are selected.)

**System Area Size**

#### ◆ System Area Size

This field displays the total number of words used for the items selected from the SYSTEM AREA SETUP (**Write:** from **1** to **5** and **Read:** from **6** to **D**).

When you press the Confirm key, the SYSTEM AREA CONTENTS screen is displayed, to confirm the selected items.



**Note:**

- The System Area settings are enabled only when using Direct Access format.
- The selected System Area items, as displayed on the screen, become the System Data Area.

# Chapter 6 – Initializing the GLC

When the Current Screen Number, Error Status, Clock Data (Current), Change Screen Number, and Display ON/Off setting items have been selected, a word address is assigned to each item, in order, as shown.

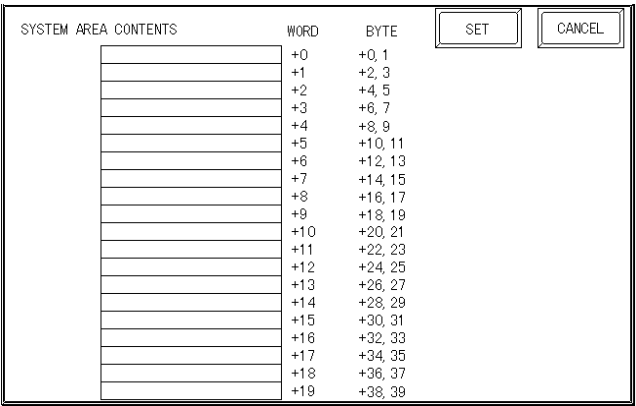

SYSTEM AREA CONTENTS	WORD	BYTE	SET	CANCEL
	+0	+0, 1		
	+1	+2, 3		
	+2	+4, 5		
	+3	+6, 7		
	+4	+8, 9		
	+5	+10, 11		
	+6	+12, 13		
	+7	+14, 15		
	+8	+16, 17		
	+9	+18, 19		
	+10	+20, 21		
	+11	+22, 23		
	+12	+24, 25		
	+13	+26, 27		
	+14	+28, 29		
	+15	+30, 31		
	+16	+32, 33		
	+17	+34, 35		
	+18	+36, 37		
	+19	+38, 39		

In the above screen, the device address used for the SET UP OPERATION SURROUNDINGS setting's SYSTEM AREA START DEV | START ADR is “+0.”

Therefore, when the SYSTEM AREA START DEV | START ADR is “D00200,” and the CHANGE SCREEN NO. setting has been designated, the address shown is “+6” and you will then need to enter “D00206” (D00200 + 6) to use this address.

**Reference** *For details about setting the SYSTEM AREA START DEV | START ADR, refer to 6.5.1 – “SET UP OPERATION SURROUNDINGS (1:1 / n:1).”*

## Chapter 6 – Initializing the GLC

### 6.3.3 GLOBAL WINDOWS SETUP

A GLC2400/2600 Series unit can display one Global Window and two Local Windows at any one time. The Global Window is common to all the display screens. The Local Window displays exclusively on a designated base screen. This section describes the GLOBAL WINDOW SETUP is described here.

#### GLOBAL WINDOW

Two options are available: **Use** and **Do Not Use**. If you select **Do Not Use**, ignore the items described below. Selecting **Use** enables the following options.

#### GLOBAL WINDOW ACCESS

Use this feature to designate whether values used by the GLC (such as the REGISTRATION NO. and the LOCATION values) are DIRECT or INDIRECT. When set as Direct, the REGISTRATION NO. and LOCATION selections are fixed to the values entered here. When set to Indirect, the WINDOW REG. NO.'s word address is used by the SYSTEM AREA as a variable. This means the REGISTRATION NO. written to it changes and, as a result, can call up multiple window screens as Global windows. You can also use this method to adjust the Global window's position by writing the desired (X,Y) coordinates to the SYSTEM AREA's LOCATION word addresses.

#### DATA FORMAT

Set up the REGISTRATION NO. and the LOCATION values as either BIN or BCD values. This field is related only to Indirect values.

#### REGISTRATION NO.

Enter the Window Screen Number used by the Global Window. This field is enabled only when GLOBAL WINDOW ACCESS is set to Direct.

#### WINDOW LOCATION

Enter the value used for the (Global Window) LOCATION. This field is enabled only when GLOBAL WINDOW ACCESS is set to Direct. Use this setting to designate the top-left coordinate on the screen registered as a Global Window. If you install the GLC vertically, (in portrait — not landscape — mode), designate the bottom-left instead of the top-left coordinate.

## 6.3.4 CHARACTER STRING DATA SETUP

Character String Data ordering varies from manufacturer to manufacturer. Set up the Character String Data order to match that of the corresponding PLC.

CHARACTER STRING DATA MODE (1-8) [   ]



**Set up the CHARACTER STRING DATA MODE to match that of the corresponding PLC. Device type and Tag settings are not available for setup.**

### ■ CHARACTER STRING DATA MODE

Set up the CHARACTER STRING DATA MODE that corresponds to that of your PLC, as specified in the following table.

- (I) Data Device Storage Order
- (II) Byte Storage Order (LH/HL), using single words
- (III) Word Storage Order (LH/HL), using double words

**CHARACTER STRING DATA MODE (1–8) List**

(I) Data Device Storage Order	(II) Byte Storage Order (LH/HL), using single word	(III) Word Storage Order (LH/HL), using double	Character String Data Mode
Storage from Start Data	LH order	LH order	4
		HL order	2
	HL order	LH order	5
		HL order	1
Storage from End Data	LH order	LH order	6
		HL order	7
	HL order	LH order	8
		HL order	3

# Chapter 6 – Initializing the GLC

## I. Data Device Storage Order

Example characters: A B C D E F G H  
 ① ② ③ ④

- Storage from Start Data

①	D100
②	D101
③	D102
④	D103

- Storage from End Data

④	D100
③	D101
②	D102
①	D103

## II. Byte Storage Order (LH/HL), using Single Words

Example characters: A B C D  
 ① ② ③ ④

- 16-bit Device LH Order

②	①	D100
④	③	D101

- 16-bit Device HL Order

①	②	D100
③	④	D101

- 32-bit Device LH Order

②	①	④	③	D100
---	---	---	---	------

- 32-bit Device HL Order

①	②	③	④	D100
---	---	---	---	------

## III. Word Storage Order (LH/HL), using Double Words

Example characters: A B C D E F G H I J  
 ① ② ③ ④ ⑤

- 16-bit Device LH Order

②	D100
①	D101
④	D102
③	D103
⑤	D104

- 16-bit Device HL Order

①	D100
②	D101
③	D102
④	D103
⑤	D104

Example characters: A B C D E F G H I J K L M N O P Q R S T  
 ① ② ③ ④ ⑤ ⑥ ⑦ ⑧ ⑨ ⑩

- 32-bit Device LH Order

②	①	D100
④	③	D101
⑥	⑤	D102
⑧	⑦	D103
⑩	⑨	D104

- 32-bit Device HL Order

①	②	D100
③	④	D101
⑤	⑥	D102
⑦	⑧	D103
⑨	⑩	D104

### Relationship between K-tag Write Character value and the PLC device.

#### ◆ 16-bit Devices

The GLC stores the character string in one internal Device, in groups of two, starting with the first pair of characters.

When nine characters make up a string, they are arranged as follows:

1 2 3 4 5 6 7 8 9 Null  
└─┘ └─┘ └─┘ └─┘ └─┘



When the characters do not divide evenly by two, NULL is added to the last character to make up the final pair and complete the string.

#### ◆ 32-bit Devices

The GLC stores the character string in one internal device address, in groups of four, starting with the first group of characters.

When there are nine characters, they are arranged as follows:

1 2 3 4 5 6 7 8 9 Null  
└─┘ └─┘ └─┘



When the characters do not divide evenly by four, NULL is added to the last character to make up the final group and complete the string.



### 6.4 SET UP I/O

---

This section describes the communication setup with the Host (PLC) and the configuration for any peripheral equipment. The SET UP I/O menu includes the SET UP SIO, SET UP PRINTER, SET UP TOUCH PANEL, COMMUNICATION SETUP, SOUND SETTINGS, EXPANSION SERIAL SETUP, EXPANSION SERIAL ENVIRONMENT SETUP, DISPLAY DEVICE SETUP, and COMMUNICATION PORT SETUP menus.

#### 6.4.1 SET UP SIO

---

This screen controls the settings related to communication with the PLCs. Be sure to match the settings listed below with the SIO setup on the Host (PLC). The settings will vary, depending on the PLC.

Be sure to match the GLC unit's SIO settings, as follows, with those of the Host (PLC).

**Reference** *GP-PRO/PBIII for Windows Device/PLC Connection Manual (included with screen creation software)*

SET UP SIO		SET	CANCEL
COMMUNICATION RATE	2400 4800 9600 19200 38400 57600 115200		
DATA LENGTH	7 8		
STOP BIT	1 2		
PARITY	OFF ODD EVEN		
CONTROL	X-CNTRL ER-CNTRL		
COMMUNICATION FORMAT	RS232C 4 LINE 2 LINE		

(Some PLCs may not be able to communicate at 57600 or 115200bps.)



If you have selected "YES" for the [SERIAL I/F CHANGE] on the [COMMUNICATION PORT SETUP] screen, or "Yes" for the [Serial I/F Switch] settings in the [Change Extend SIO Type] command, in the Screen Editor's [Project] menu, do not enter all of the settings related to device communication using the Extended SIO Script Protocol here. ([SET UP SIO] screen) These settings are required to set using the [EXPANSION SERIAL COMMUNICATION SETUP] screen.

**Reference** **6.4.6 EXPANSION SERIAL COMMUNICATION SETUP**

#### COMMUNICATION RATE

The COMMUNICATION RATE (baud rate) is the data communication speed, measured in bits per second (bps), between the GLC and the PLC. Match both the PLC and the GLC units' COMMUNICATION RATE values. Depending on the rate selected, you may not be able to use certain PLCs.

**Reference** *GP-PRO/PBIII for Windows Device/PLC Connection Manual (included with the screen creation software)*

#### DATA LENGTH / STOP BIT

For data communication, use the following settings:

- DATA LENGTH: 7 or 8 bits
- STOP BIT: 1 or 2 bits

#### PARITY

Use this setting to specify whether an ODD or EVEN number parity check, or none at all (OFF), will take place during communication.

### CONTROL

The CONTROL setting prevents the overflow of data transmitted and received. Select either the XON/XOFF or the ER (DTR) control.

### COMMUNICATION FORMAT

Select one of the following options for the Communication Format setting:

- RS-232C
- RS-422 (4-line)
- RS-422 (2-line)



- **Note:** When using an RS-422 cable and the Memory Link format, be sure to select the 4-line option.

**Reference** *GP-PRO/PBIII for Windows Device/PLC Connection Manual*  
(included with the screen creation software)

- If you have selected "YES" for the [SERIAL I/F CHANGE] on the [COMMUNICATION PORT SETUP] screen, or "Yes" for the [Serial I/F Switch] settings in the [Change Extend SIO Type] command, in the Screen Editor's [Project] menu, be sure to select RS-232C.

## Chapter 6 – Initializing the GLC

### 6.4.2 SET UP PRINTER

This screen sets up the designated printer that will be connected to the GLC.

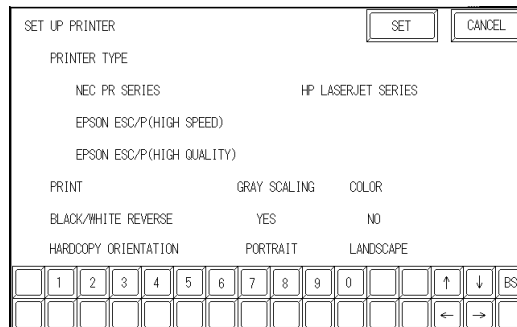

#### PRINTER TYPE

Printers that can be used with the GLC are those that are compatible with NECPC-PR201/PL, EPSON ESC/P24-J84(C), and HP Laser Jet PCL 4 commands, EPSON PM/Stylus (6-color ink), and EPSON Stylus (4-color ink).



**Note:**

- There is no difference in the quality and printing speed between EPSON ESC/P (High Speed) and EPSON ESC/P (High Quality) when the GLC (corresponding to 64 colors or more) is used to print out hard copy of screen images.
- Using EPSON PM/Stylus (6-color ink), EPSON Stylus (4-color ink) printers, GP-PRO/PBIII for Windows Ver.6.2 or later is required. For details, **Reference** ■ EPSON PM Series / EPSON Stylus Series

#### PRINT

Two selections — GREY SCALING and COLOR — are available. If you select GREY SCALING, the same pattern will be applied to:



**Note:**

- Blue and Green • Light Blue and Red • Purple and Yellow
- Since HP LaserJet Series printers do not support color printing, be sure to specify GREY SCALING.
- Fewer GREY SCALING printing patterns than color patterns (64 colors) are available, and not all colors can apply to the GREY SCALING pattern range. Therefore, light-colored characters cannot be printed.

#### BLACK / WHITE REVERSE

This setting is used to reverse the background and display color with black/white color attributes. When the color is reversed, the background color prints out as black, and the character's color prints out as white.

- When BLACK/WHITE REVERSE is selected, the background color is black and the display color is white.



- When BLACK/WHITE REVERSE is **not** selected:



**Note:**

This setting is enabled only when a screen display is printed. Alarm or Recovery data output is always printed as black, regardless of the setting selected.

### HARDCOPY ORIENTATION (only with GLC2600T)

This setting designates the direction — horizontal or vertical — of the GLC2600 unit's screen copy printout.



EPSON PM/Stylus (6-color ink) and EPSON Stylus (4-color ink) models do not support "Vertical" printing. When "Vertical" is selected, printing is not performed correctly.

### ■ EPSON PM Series / EPSON Stylus Series

#### ◆ Restrictions for using EPSON PM / EPSON Stylus Series printers

- EPSON PM/Stylus (6-color ink) and EPSON Stylus (4-color ink) printers do not support "Vertical" printing for "HARD COPY ORIENTATION" (screen copy printout.)
- When printing using an EPSON PM/Stylus (6-color) or an EPSON Stylus (4-color) printer, GLC screen updating (tag processing, etc.) will be slower.
- Since OFFLINE Self-diagnosis (Printer I/F Check) is used only for ASCII code output, it will not produce a correct printout.
- A magnification value of 1 to 4 can be specified while printing out screen hard copy. With GLC2600T units, a magnification value of 4 may cause the printout to exceed the width of an A4 size paper.
- When screen data printout uses levels of shading, printout from these printers will differ from a different type printer (PR201, etc.). This is because colors are recognized based on shading level patterns and not on the density of shading.

#### ◆ Extension Settings

When specifying EPSON PM/Stylus (6-color) or EPSON Stylus (4-color) as "PRINTER TYPE", "PRINT MAGNIFY" feature for screen data printout can be specified in the [SET UP PRINTER (EXT-SET)] screen.

Specify either EPSON PM/Stylus (6-color) or EPSON Stylus (4-color) as "PRINTER TYPE", and touch the  key.

[SET UP PRINTER (EXT-SET)] screen will appear. Touch the desired magnification.

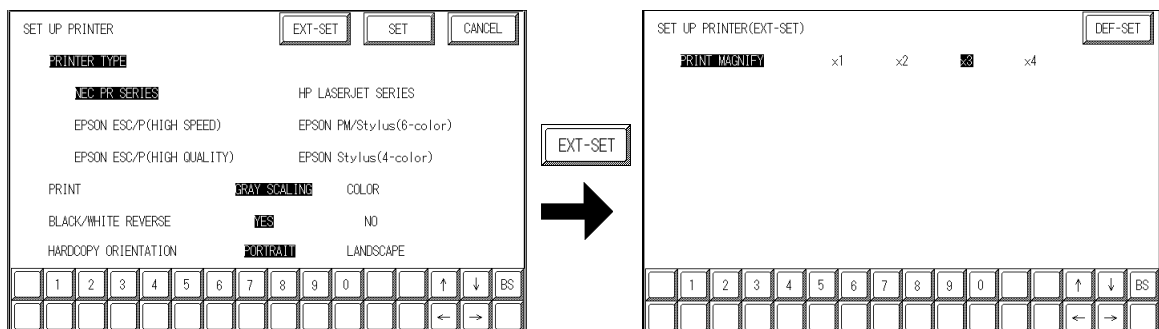

With GLC2600T units, a magnification value of 4 may cause the printout to exceed the width of an A4 size paper.



## 6.4.3 SET UP TOUCH PANEL

Set up the touch panel's Touch Operation and Force Reset modes, and adjust the Display Device settings in this screen. Depending on the GLC type, these settings may vary.

SET UP TOUCH PANEL				SET	CANCEL
TOUCH OPERATION MODE	ONE POINT	TWO POINTS	NO SLIDE		
FORCE RESET	ON	OFF			
CONTRAST ADJUSTMENT	ON	OFF			
BRIGHTNESS ADJUSTMENT	ON	OFF			
USE TOUCH PANEL AFTER BACKLIGHT BURNOUT		YES	NO		

(Contrast and brightness settings are not applicable for some display devices.)

### TOUCH OPERATION MODE

Designates One Point, Two Points, or No Slide. When No Slide is selected, the screen will NOT respond to one's finger dragging across the touch screen. Only individually-selected points will register.

### FORCE RESET MODE

Enables or disables the display of the menu bar (force reset page). When set to "Yes," the menu bar will display.

#### ◆ To Display the Menu Bar

To enter the SYSTEM RESET mode, press the bottom-right corner of the screen (position 1, below), and then touch the top-right and bottom-left corners (positions 2 and 3).

To activate Reset, touch the RESET button; to change to OFFLINE Mode, touch OFFLINE.

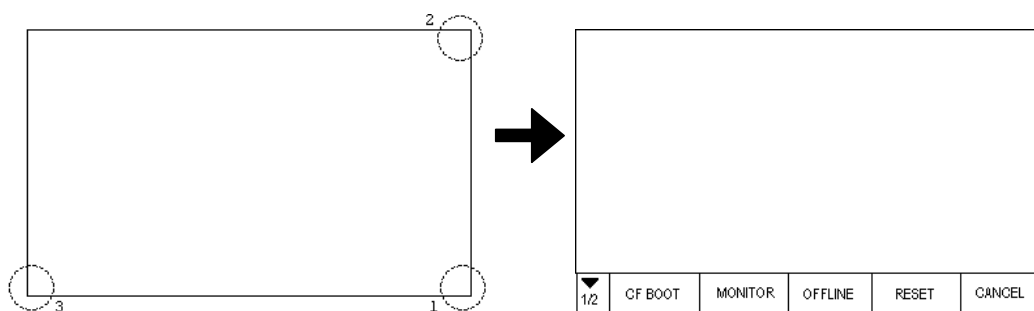

**You can perform FORCE RESET in either RUN mode or OFFLINE mode.**



- The Menu Bar will not display when the GLC is starting up.
- Entering SYSTEM RESET is possible even when the PLC and GLC are not communicating.

## Chapter 6 – Initializing the GLC

### CONTRAST ADJUSTMENT

This setting is not available with the GLC2000 Series.

### BRIGHTNESS ADJUSTMENT

When BRIGHTNESS ADJUSTMENT is set to ON, you can adjust the brightness by touching the GLC unit's screen. To enter BRIGHTNESS ADJUSTMENT mode, press the screen's bottom-right corner (screen A, position 1, below), and then touch the bottom-left corner (position 2). When the BRIGHTNESS ADJUSTMENT screen (B) appears, touch the bar's left side to brighten the display, or the right side to dim the display. Four levels of adjustment are available with this unit.

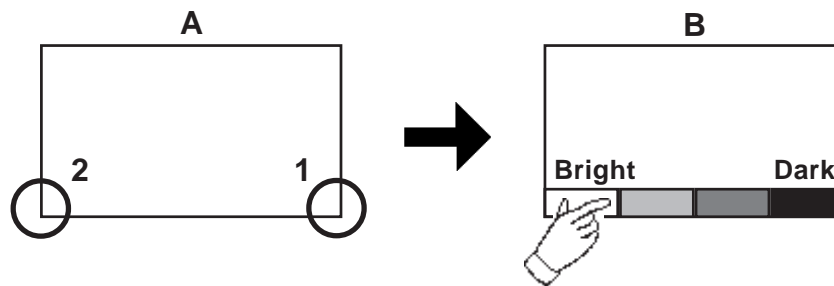

#### Note:

- To exit the BRIGHTNESS ADJUSTMENT mode, touch anywhere above the Brightness Adjustment bar.
- You cannot enter the BRIGHTNESS ADJUSTMENT mode while the GLC is starting up.
- BRIGHTNESS ADJUSTMENT settings can be made during RUN mode (PLC<-->GLC communication).

### USE TOUCH PANEL AFTER BACKLIGHT BURNOUT

This option allows the user to enable [ON] or disable [OFF] the touch operation when the backlight burns out. Setting this item to [OFF] prevents the GLC from sending input signals to the PLC.



#### Note:

When the Backlight Burns Out:

- The Status LED's orange light will turn ON.
- The System Data Area's Status bit 10\*1 will turn ON.
- If the SYSTEM RESET item is set to ON, only SYSTEM RESET can still be performed by touch operation.
- If the GLC is in OFFLINE mode, the touch-panel operation will become enabled, regardless of the settings.



**Normally, the unit detects backlight burnout by monitoring the current. However, depending on the problem with the backlight, the unit may fail to detect this condition.**

1. Bit +6 (when using the Direct Access method), and bit +11 (when using the Memory Link method), will turn ON.

**Reference** *GP-PRO/PBIII for Windows Device/PLC Connection Manual* (included with screen creation software)

## 6.4.4 COMMUNICATION SETUP

This section explains how to use the Retry command to deal with errors, including those that occur during GLC and PLC communication.

COMMUNICATION SETUP		SET	CANCEL
RECEIVE TIMEOUT (1-127)	[   ]	SECOND	
RETRY COUNT (0-255)	[   ]		

### RECEIVE TIMEOUT (1 to 127)

Use a numeric value to set a period of time in which the GLC receives data from the PLC. If the cable is not connected, data communication will Timeout after one second, regardless of this setting's value.

The default value for the RECEIVE TIMEOUT setting is 10 seconds.



An error message may appear on your personal computer if:

- You transfer screens from your PC to the GLC after a PLC communication error has occurred and the error is not yet cleared.
- Your GLC unit's RECEIVE TIMEOUT value is set to 30 seconds or more.

### RETRY COUNT (0 to 255)

Use this setting item to designate the number of times the GLC tries to send data to the PLC when a PLC communication error occurs. After the GLC unit's specified number of attempts has failed to send data to the PLC, an error message will appear on the GLC.

The default value for the Retry Count setting is "2."

## 6.4.5 SOUND SETTINGS

SOUND SETTINGS			SET	CANCEL
START-UP SOUND	BUZZER	SOUND		

### START UP SOUND

Select the type of sound that is output when the GLC starts. If BUZZER is selected, the GLC unit's internal buzzer will be sound. If SOUND is selected, a sound will output from the speaker connected to the GLC.



## Chapter 6 – Initializing the GLC

### 6.4.6 EXPANSION SERIAL SETUP

This section describes the communication setup for a device connected to the Expansion Serial Interface. This setup screen will not display unless the communication protocol for the Expansion Serial Interface (specified with SET UP EXPANSION SIO of the GLC screen creation software package) is transferred to the GLC.



If you have selected "YES" for the [SERIAL I/F CHANGE] on the [COMMUNICATION PORT SETUP] screen, or "Yes" for the [Serial I/F Switch] settings [Change Extend SIO Type] command, in the Screen Editor' [Project] menu, enter all of the settings related to device communication using the Extended SIO Script Protocol here, [EXPANSION SERIAL COMMUNICATION SETUP] screen.

EXP. SERIAL SETUP		SET	CANCEL
COMMUNICATION RATE	2400 4800 <b>9600</b> 19200 38400		
DATA LENGTH	7 <b>8</b>		
STOP BIT	<b>1</b> 2		
PARITY	<b>OFF</b> ODD EVEN		
RI/VCC (COM2)	<b>RI</b> VCC		
COMMUNICATION FORMAT	<b>RS232C</b> 4 LINE 2 LINE		
(RI/VCC (COM2)) is not related to setup of [SERIAL I/F CHANGE].)			
	1 2 3 4 5 6 7 8 9 0	↑	↓
		←	→
			BS

#### COMMUNICATION RATE

The COMMUNICATION RATE (baud rate) is the data communication speed, measured in bits per second (bps), between the GLC and the device connected to the Expansion Serial Interface.

The supported communication rates vary depending on the connected device. Refer to the instruction manual of the connected device for more information. The initial setting varies depending on the communication protocol for the Expansion Serial Interface being transferred.

#### DATA LENGTH

Set the DATA LENGTH to 7-bit or 8-bit data.

#### STOP BIT

Set the STOP BIT to either 1- or 2-bit.

#### PARITY

Use this setting to specify whether an ODD or EVEN number parity check, or none at all (OFF), will take place during communication.

### RI / VCC

Use this setting to specify the Expansion Serial Interface 9-pin to be at RI or VCC. VCC is available only when the setting is at the operation mode. VCC will be switched to RI when the operation mode is switched to the offline mode.

When the communication protocol for the Expansion Serial Interface is not transferring, the setting is fixed to RI.



---

**The SIO circuit can be damaged if a checking jig for the Expansion Serial Interface is installed while VCC is selected.**

---

### COMMUNICATION FORMAT

Select one of the following options for the communication format: RS-232C, RS-422 (4 line), or RS-422 (2 line).

## Chapter 6 – Initializing the GLC

### 6.4.7 EXPANSION SERIAL ENVIRONMENT SETUP

---

The following setting varies depending on the communication protocol for the Expansion Serial Interface being transferred.

This section explains the case where SERIAL CODE READER (LS) is transferred.

Use this setting when a serial code reader is connected to the Expansion Serial Interface to read serial code data.

EXP. SERIAL ENVIRONMENT SETUP

SET CANCEL

SCANNING MODE

DEFAULT

DENSO QR Code Scanner

TOHKEN Code Scanner

1 2 3 4 5 6 7 8 9 0 ↑ ↓ BS

← →

#### SCANNING MODE

Set the SCANNING MODE according to your scanner's settings.

The communication format for each mode is shown below:

- DEFAULT

Code data	Terminator (CR)
-----------	-----------------

- DENSO QR code scanner

Header (STX)	Code mark (7 bytes)	No. of digits (4 bytes)	Code data	Terminator (CR)	BCC (7 bytes)
--------------	---------------------	-------------------------	-----------	-----------------	---------------

- TOHKEN Code scanner

Header (STX)	Code data	Terminator (CR + LF)
--------------	-----------	----------------------

## 6.4.8 SETUP CAPTURE OPERATION

---

### ■ SETUP CAPTURE OPERATION

This screen contains the settings required to control the screen capture operation. This feature captures GLC screen information as a JPEG file and saves it to the GLC unit's CF Card.

SET UP CAPTURE OPERATION

SET CANCEL

QUALITY(1-100) ( )

BLACK/WHITE REVERSE YES NO

1 2 3 4 5 6 7 8 9 0 ↑ ↓ BS

← →

#### QUALITY (1-100)

Sets the captured image quality. The image quality can be set from 1 to 100. 100 is the highest quality.

#### B/W REVERSE

The white part in the image that is created in the screen creation program is reversed to black, and the black part is reversed to white.



All other colors (except white and black) are not reversed.

## Chapter 6 – Initializing the GLC

### 6.4.9 SET UP DISPLAY DEVICE

---

This setting is not supported by the GLC2400T/26000T unit. Return to the previous screen by touching the CANCEL button.

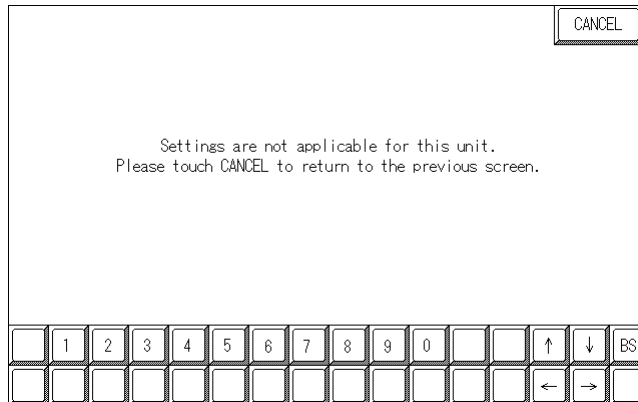

### 6.4.10 FUNCTION SETUP

---

This setting is not supported by the GLC2400T/26000T unit. Return to the previous screen by touching the CANCEL button.

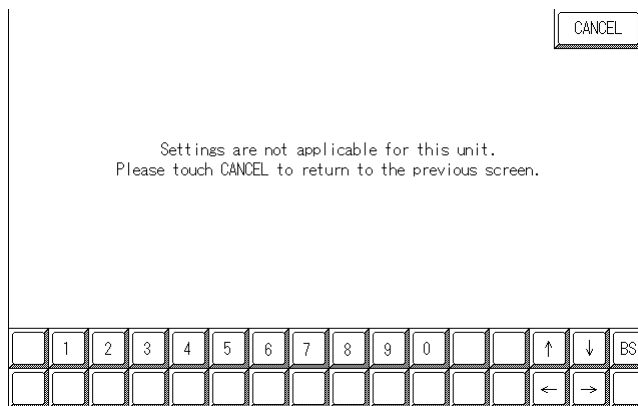

## 6.4.11 COMMUNICATION PORT SETUP

This screen allows you to set up the connection environment of the GLC's communication port.

COMMUNICATION PORT SETUP												SET	CANCEL	
SERIAL I/F CHANGE	NO	YES (COM1 <-> COM2)												
RI/VCC (COM2)	RI	VCC												
([RI/VCC (COM2)] is not related to setup of [SERIAL I/F CHANGE].)														
	1	2	3	4	5	6	7	8	9	0		↑	↓	BS
												←	→	

### SERIAL I/F CHANGE

Selecting "YES (COM1 <->COM2)" designates that the communication used for the Extended SIO Script Protocol starts at the Serial I/F (COM1). Also, the communication used for the device/PLC starts at the Expansion Serial I/F (COM2).

In OFFLINE mode, the SERIAL I/F CHANGE setting is set to "NO".



- After selecting "YES (COM1 <->COM2)", enter all of the settings related to device communication using the Extended SIO Script Protocol, [EXPANSION SERIAL COMMUNICATION SETUP] screen. Enter all of the settings related to Device/PLC communication, [SETUP SIO] screen.
- To use the "SERIAL I/F CHANGE" feature, the system of GP-PRO/PB III for Windows Ver.6.2 or later is required to be transferred to the GLC.

### RI/VCC (COM2)

This setting designates if the Serial Interface's #9 pin is used for RI or for VCC.

## 6.5 PLC SETUP

Set up the GLC unit's System Area and the Unit Number in this screen. Because 1:1 and n:1 GLC connections use different settings, confirm your connection requirements before using any settings. The following assumes that the Direct Access format is used.



**Note:**

- The screens that appear depend on the PLC type you selected in the screen creation software.

**Reference** *GP-PRO/PBIII for Windows Device/PLC Connection Manual* (included with screen creation software)

- When the GP-PRO/PBIII for Windows Simulation feature is used, the OPERATION SURROUNDINGS menu cannot be used.

### 6.5.1 SET UP OPERATION SURROUNDINGS (1:1/n:1)

Enter the PLC System Data Area and the Unit Number settings in this screen. The same options are available for both 1:1 and n:1 (multi-link) connections.

For an n:1 (multi-link) connection, System Data Area settings must be setup for each GLC connected to the PLC.

**Reference** *GP-PRO/PBIII for Windows Device/PLC Connection Manual* (included with screen creation software)

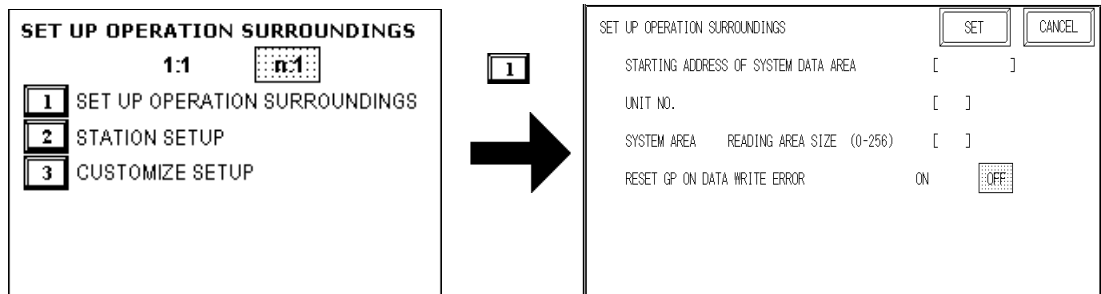

#### STARTING ADDRESS OF SYSTEM DATA AREA

Setup the System Data Area's Start Address. Device addresses that can be allocated will differ depending on the type of PLC used.

**Reference** *GP-PRO/PBIII for Windows Device/PLC Connection Manual* (included with screen creation software)

#### UNIT NO.

Enter the PLC UNIT number in this setting. Make sure that it matches the PLC's unit number setting.

#### SYSTEM AREA READING AREA SIZE (0-256)

When using a Block Display Trend Graph, setup the Reading Area Size (in word units) to match the Trend Graph's data size. Use this feature when you wish to allocate the Reading Area in the PLC Data Register (D), or Data Memory (DM).



**Note:**

If you are not using the Reading Area, leave the default values that are set to "0" intact, to allow high-speed data communication performance.

#### RESET GP ON DATA WRITE ERROR

Designates the mode which enables you to cancel the error from the error display when the Write error occurs.

## 6.5.2 STATION SETUP (n:1)

STATION SETUP, required with an n:1 (multi-link) setup, checks whether data communication is being performed correctly between the GLC and the PLC.

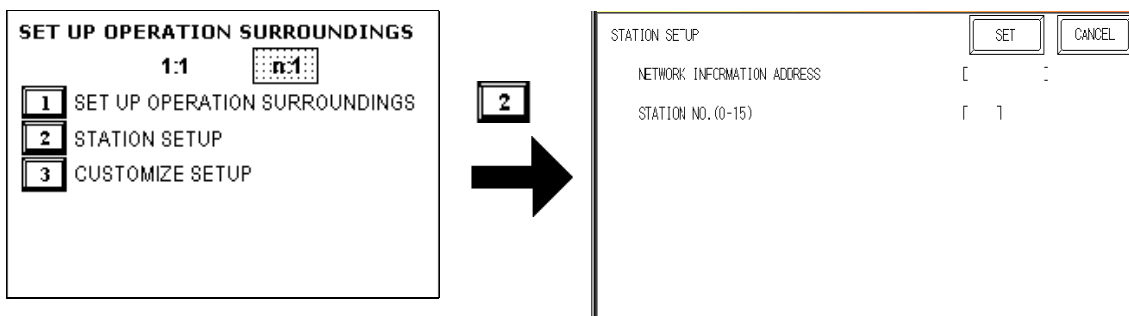

### NETWORK INFORMATION ADDRESS

With an n:1 (multi-link) connection, the Network Information setting uses two (2) words — a Connection List and a Validation List (described in this section) — for its data. These areas are allocated in the PLC’s Data Register (D) or Data Memory (DM). Addresses which can be allocated will differ depending on the PLC type.

**Reference** *GP-PRO/PBIII for Windows Device/PLC Connection Manual (included with screen creation software)*

#### PLC Data Register

+0	CONNECTION LIST	PLC-->GLC
+1	VALIDATION LIST	GLC-->PLC



**In the NETWORK INFORMATION ADDRESS, set up the same address to all the GLCs connected to the same link unit. Also, when the link unit has two ports, be sure they do not use the same address.**

### ◆ Connection List

The word address for the Connection List sets up the number of GLCs connected to the PLC, which must have been entered previously in the PLC. When these GLCs are connected to the PLC, the corresponding PLC bit number for each GLC Station turns ON (see below).



When the GLC is connected to the PLC, and the option of GLC-only correspondence ends and OFFLINE mode is entered, the GLC Station Number then turns the corresponding PLC bit OFF.





## Chapter 6 – Initializing the GLC

For example, when four GLCs — bits 0, 2, 3, and 5 — are connected, 002D (h) is written.

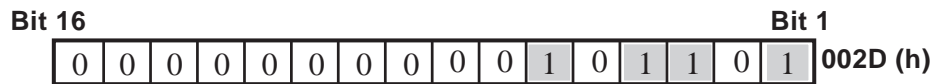

- **Be certain to setup this data before running.**
- **Turn all bits not related to the GLC OFF.**

### ◆ Validation List

This area responds to the correspondence from each connected GLC. In the Validation List, when the same bit numbers as the Connection List turn ON, the correspondence is accepted. The Station Numbers of the communicating GLCs turn their corresponding PLC bit number ON.

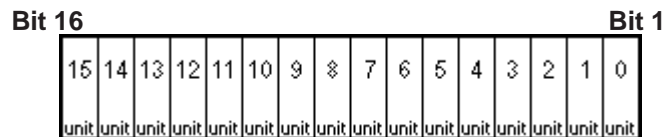

If the correspondence between the GLC and PLC is correct, the same value as in the Connection List is written to the Validation List.

For example, the value 002D (h) in the Connection List, setup as the 0 bit, 2 bit, 3 bit, and 5 bit, writes to the Validation List.

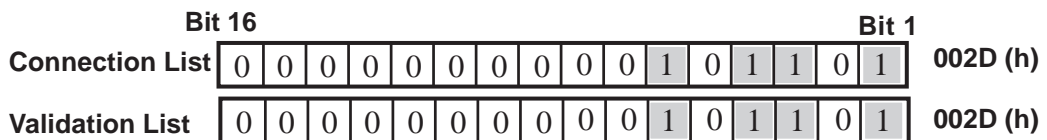

- **When the Connection List and Validation List do not match, a COMMUNICATION ERROR occurs. Check the setup again.**
- **When changing the connection, first turn all the bits OFF.**

### STATION NO. (0-15)

This is the setup for the GLC Station Number mentioned above. The setup range is from 0 to 15, and the only other restriction is the GLC STATION NO. must be unique in the system. If STATION NO.'s are repeated, a COMMUNICATION ERROR occurs.



The STATION NO. is the number allocated to the particular GLC unit. This number is not related to the Link Unit Machine number.

## 6.5.3 CUSTOMIZE SETUP (n:1)

The Customize function modifies the n:1 (multi-link) connection’s communication method to make it more efficient. To perform GLC<-->PLC communication efficiently, the user should first determine whether they wish to have Operation or Display priority set for the GLC. Based on this, the communication response speed can be upgraded. (However, this also depends on the complexity of the screen information displayed.)

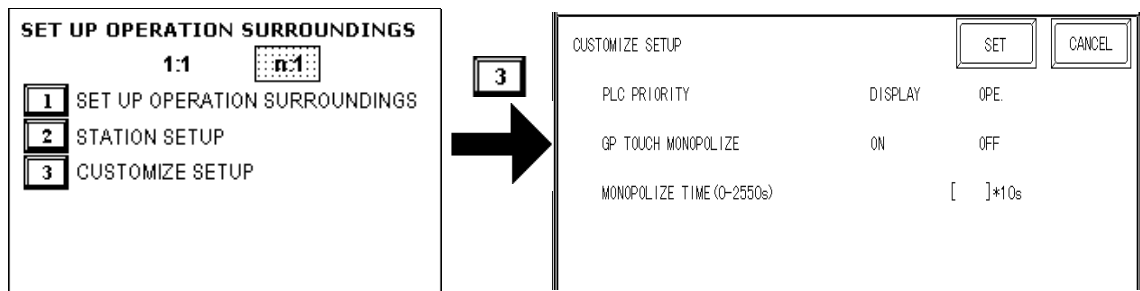

### ■ PLC PRIORITY

Depending on how the GLC is used, select either Operation priority (OPE.) or Display priority (DISPLAY).

### ◆ Display

Setup the GLC to this option when using the GLC mainly as a monitor screen. The GLC will command a higher display speed as a result; however, the response time for the touch panel’s operations will slow.

### ◆ Operation

Set up the GLC to this option when using the GLC mainly as a monitor screen. The touch panel’s numeric value input or switch function response speed will become higher as a result.

When “OPE.” is selected, the response time for the touch panel’s operation is quicker than the response time when the “DISPLAY.” is selected, however, the display refresh cycle time will slow.



- In a standard network setup, use the same settings for all connected GLCs.
- To increase the display speed, be sure the addresses used are consecutive addresses. When bit addresses are used, use addresses that are consecutive to word units.

## Chapter 6 – Initializing the GLC

### ◆ Speed Difference between Display Priority and Operation Priority

When using the Mitsubishi Electric Corporation A3A PLC, with consecutive addresses (80 words, not including the System Area), the difference in reading speed is as shown in the following graphs.

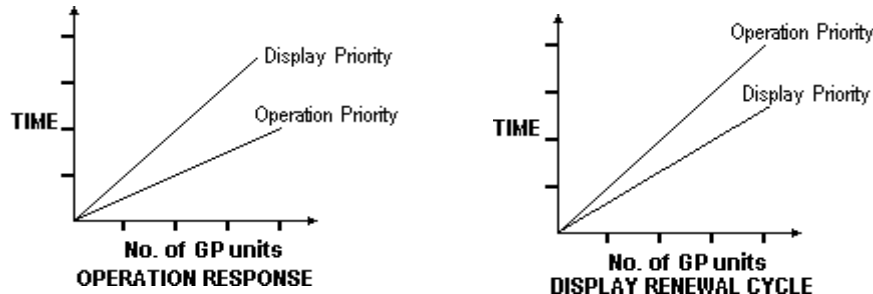

### ■ GP TOUCH MONOPOLIZE

Touch panel monopolization can be turned ON or OFF via this screen. When you want to use the PLC exclusively, for example with a momentary-type switch from the touch panel, turn GP TOUCH MONOPOLIZE ON.

When this setting is ON, the touch panel uses the PLC exclusively whenever the momentary switch is pressed. This allows you to use a touch panel switch for unit inching operations. Exclusive use ends when you stop pressing the panel.

**Reference** *GP-PRO/PBIII for Windows Device/PLC Connection Manual (included with screen creation software)*

### ■ MONOPOLIZE TIME (0-2550S)

Set Bit 7 of the System Data Area LS14 to ON to set monopolizing time.

This field controls the length of time for the monopolize process when no other touch panel operations are performed. The Monopolize process ends when the time set here elapses, and the 7th bit of word address LS14 turns OFF.

After cancelling GP TOUCH MONOPOLIZE, it will return to n:1 (multi-link) communication.



**Note:**

- Pressing the touch panel in the middle of the monopolize process interrupts the MONOPOLIZE TIME function, and ends exclusive use.
- When MONOPOLIZE TIME is set to 0, the monopolize function does not end automatically.

**Reference** *For further information about the contents of System Data Area LS6 (status) and LS14 (control), refer to the GP-PRO/PBIII for Windows Device/PLC Connection Manual (included with the screen creation software).*

## 6.5.4 ETHERNET SETUP

This menu is for Ethernet settings. This information is used as setting data during GLC setup or screen transfer, or, if the Pro-Server software is used, for the 2-Way Driver.

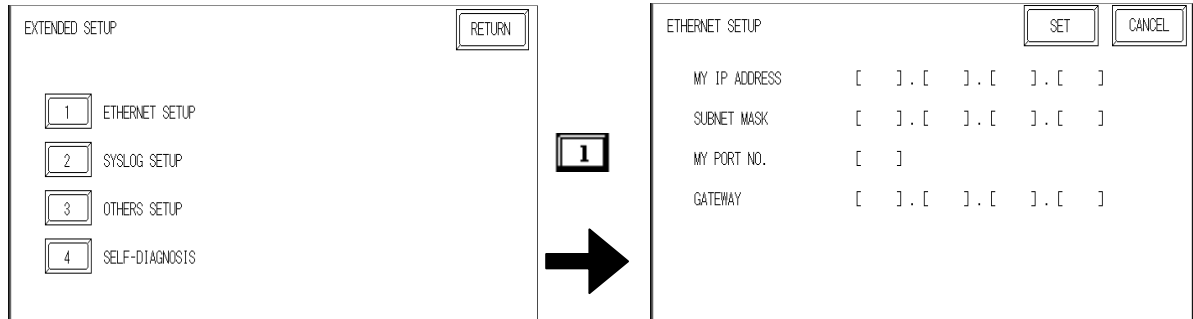

- Enter the **ETHERNET SETUP** settings after receiving information from your network's system administrator.
- Be sure to enter a unique IP address, not one used for other GLCs or by the host.

### MY IP ADDRESS

Sets up the GLC unit's IP address. The IP address is 32 bits and designated in four 8-bit units, entered in decimal.



**Note:** To use Ethernet networking, click on [Initial Settings], [PLC Setup], [PLC Setup] and [Ethernet Setup].

### SUBNET MASK

Sets the subnet mask. If you are not using a subnet mask, enter "0."



**Note:** To use Ethernet networking, click on [Initial Settings], [PLC Setup], [PLC Setup] and [Ethernet Setup].

### MY PORT NO.

Sets the 2-Way Driver Port No. using a value from 1024 to 65535. Starting from the value entered here, a total of 10 consecutive ports can be used. The default setting is [8000].



**Note:** To use Ethernet networking, click on [Initial Settings], [PLC Setup], [PLC Setup] and [Ethernet Setup] and select the corresponding Ethernet protocol Port No.

### GATEWAY

Sets up the gateway's IP address. Only a single gateway can be set up. If you are not using a gateway, enter "0."

## Chapter 6 – Initializing the GLC

### 6.5.5 SYSLOG SETUP

These settings are used for outputting 2-Way driver's operation logs. Therefore, if you are not using the Pro-Server software, these settings are not necessary.

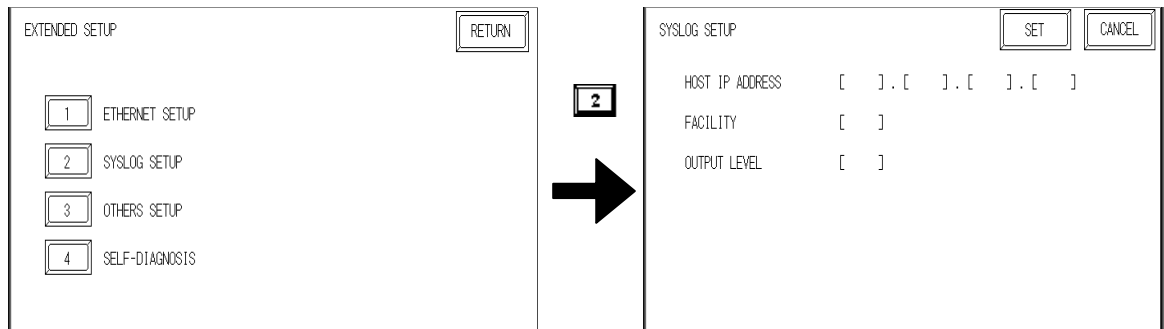

#### HOST IP ADDRESS

Sets up the IP address of the host computer that will output the 2-Way driver's operation logs.

#### FACILITY

Sets up the facility.

#### OUTPUT LEVEL

Sets up the output level.

**Reference** For details about Pro-Server and SYSLOG, refer to *Pro-Server with Pro-Studio for Windows Operation Manual* (included in the Pro-Server with Pro-Studio for Windows software package).

### 6.5.6 OTHERS SETUP

Designates the GLC operation performed when a 2-Way driver error occurs.

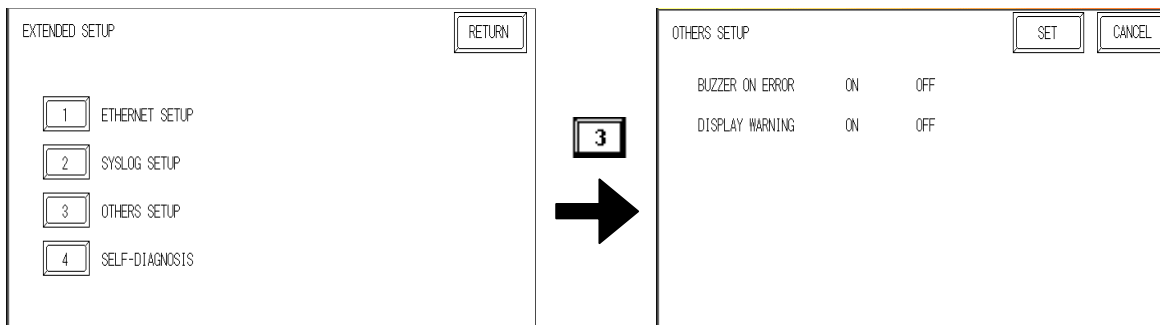

#### BUZZER ON ERROR

Enables/disables the buzzer sound output produced when an error related to the 2-Way driver operation occurs.

#### DISPLAY WARNING

Enables/disables the warning message display used when an error related to the 2-Way driver operation occurs.

### 6.5.7 SELF-DIAGNOSIS

Runs the Self Diagnosis program for the Ethernet operation. The GLC must be connected to the Ethernet network prior to running this program.

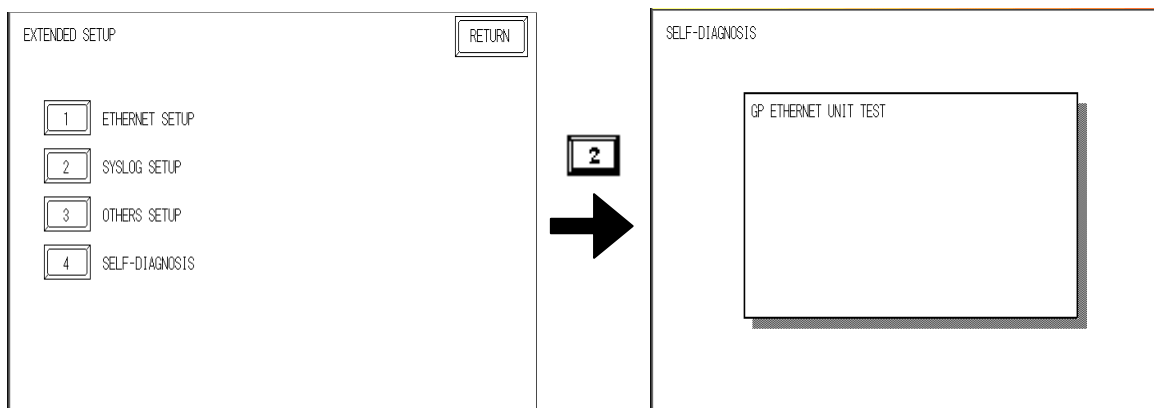

When no error is detected, the message “OK” appears. If an error is detected, the message “NG” will appear.

Be sure that this Self-Diagnosis program is used only for the Ethernet operation. If you wish to run the general Self-Diagnosis program, use the Main Menu’s SELF-DIAGNOSIS feature.

**Reference**  7.2 – “SELF-DIAGNOSIS”

## Chapter 6 – Initializing the GLC

### 6.5.8 Controller Settings

---

The setting items included in the Controller Menu are the CONTROLLER SETTING 1, CONTROLLER SETTING 2, CONTROLLER SELF-DIAGNOSIS, COPY TO FEPRM, and Flex Network Driver\*<sup>1</sup>. This section describes the CONTROLLER SETTINGS listed in the CONTROLLER SETUP menu. For other menu items, see the following list.

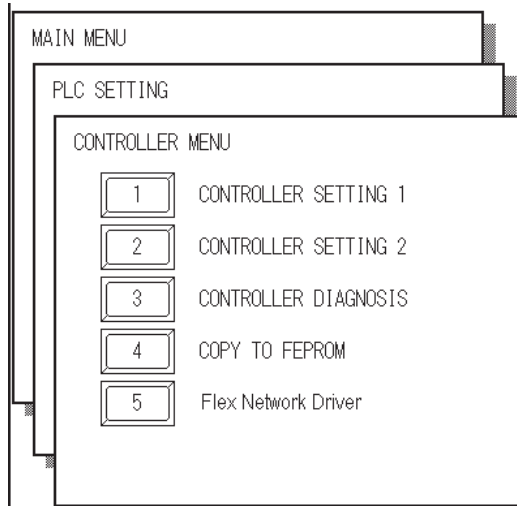

#### CONTROLLER SELF-DIAGNOSIS

▼ **Reference** ▼ *Section 7.2.3 – “List of Controller Self-Diagnosis Items”*

#### COPY TO FEPRM

▼ **Reference** ▼ *Pro-Control Operation Manual (included with Pro-Control Editor)*

#### Flex Network Driver

▼ **Reference** ▼ *Pro-Control User’s Manual (included with Pro-Control Editor)*

---

1. Will be displayed when you download logic program configured by Flex Network Driver.

Information set by the Pro-Control Editor or GLC Controller Settings are stored in the GLC unit's nonvolatile memory. Although each entry in the Controller Settings has a default setting, they should be set according to your application.

CONTROLLER SETTING 1		DEF.	SET	ESC
TARGET SCAN TIME	(10-2000ms)	[ ]	ms	
PERCENT ALLOCATION	(0-50%)	[ ]	%	
CONTROLLER STATE		START	STOP	DEFAULT
STOP ON MINOR FAULT		ON	OFF	
WATCHDOG TIMER	(100-3000ms)	[ ]	ms	

	1	2	3	4	5	6	7	8	9	0			↑	↓	BS
													←	→	

### CONTROLLER SETTING 1

#### TARGET SCAN TIME

Use Target Scan Time to set the time periods for the Controller Operation and the Display Operation Time functions. The Controller Operation Time function sets the time it takes to execute the I/O reading, Logic Program, and I/O writing.

The setting range for Target Scan Time is between 10 and 2000 ms. When Target Scan is set, the maximum time allocated to the Controller Operation Time function is 50%.

#### PERCENT ALLOCATION

Use Percent Allocation to set the ratio of Controller Operation Time function in Target Scan Time. The setting range for Percent Allocation is between 0 and 50%. When Percent Allocation is set, Target Scan is disabled.

#### CONTROLLER STATE

This item sets the Operation Mode — START, STOP, or DEFAULT — when the power is ON.

#### STOP ON MINOR FAULT

This item either stops the Controller Operation or executes a logic program when a minor fault occurs. If you wish the operation to continue after an anomaly occurs, set this switch to “Continue.” If you wish to stop the operation, set the switch to “Stop.”

**▼ Reference ▲** *Pro-Control Editor Online Help*

#### WATCHDOG TIMER

Sets the Watchdog Timer (WDT) for the Controller Operation Time and the GLC Operation Time functions to between 100 and 3000 ms. Input the value in units of 100 ms.



## Chapter 6 – Initializing the GLC

CONTROLLER SETTING 2													DEF.	SET	ESC
ENABLE I/O													ON	OFF	
CHANGE SCREEN CHECK													ON	OFF	
	1	2	3	4	5	6	7	8	9	0			↑	↓	BS
													←	→	

### CONTROLLER SETTING 2

#### ■ Enable I/O

Sets whether to enable I/O or not.

#### ■ CHANGE SCREEN CHECK

After #Screen is used to perform the screen change, the #Screen setting value is reset to "0". Using the ON (initial) setting will clear the #Screen value to "0".

**Reference** Refer to the *Pro-Control Operation Manual* (included in the GP-PRO/PB III C-Package).

## 6.6 INITIALIZE MEMORY

---

This section explains how to initialize the GLC unit's internal memory (screen data), or how to initialize a CF card inserted in the GLC. Select one of the menu items, [INITIALIZE MEMORY], [INITIALIZE CF CARD] and [CSV DATA INDEX].

### 6.6.1 INITIALIZE GLC MEMORY

---

This will erase all GLC screen data (internal memory). Back up SRAM will also be initialized.

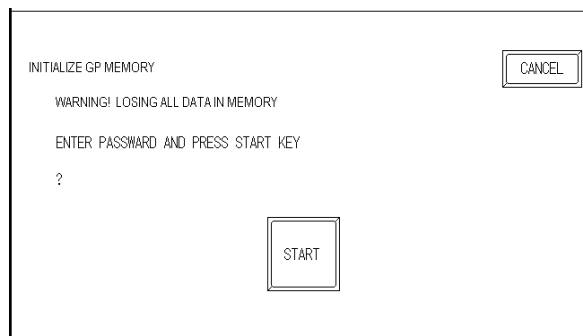

- You cannot cancel the Initialization procedure after pressing START. Do NOT turn the power off when initializing.
  - All data in SRAM will be erased.
  - Initialization does not erase the SYSTEM SET UP, the SIO protocol, or the internal clock settings.
- 

To initialize the GLC internal memory, enter the default password, **1101**, or the password entered in the SYSTEM SETUP screen.

**Reference** *Section 5.3 – “INITIALIZATION”*



The time required for Initialization is between 10 and 20 seconds.

## Chapter 6 – Initializing the GLC

### 6.6.2 INITIALIZE CF CARD

CF Card initialization deletes all CF Card data installed in the GLC.



**Initialization cannot be canceled once the START switch is touched.**

INITIALIZE CF CARD

WARNING! LOSING ALL DATA IN CF CARD

ENTER PASSWORD AND PRESS START KEY

?

CANCEL

START

Initializes the CF Card. Enter either the default password “1101” or the password you designated in the SYSTEM SETUP menu.

**Reference** For details about entering the password’s numeric values, see *Section 5.3 – “INITIALIZATION.”*

### 6.6.3 CSV DATA INDEX

Specific data-transfer CSV files (ZR\*\*\*\*\*.CSV) on the CF Card can be transferred from the CF Card directly to the PLC (filing) or from the PLC directly to the CF Card (logging). For the details about the CSV Data Transfer Function,

**Reference** *GP-PRO/PB III for Windows Tag Reference Manual*

Here creates the index file of the CSV files that are saved into the CF card with the CSV data transfer function.

CREATE CSV DATA INDEX

THE INDEX FILE OF THE CSV DATA IN CF CARD IS UPDATED.

INSERT CF CARD AND PRESS START KEY.

CANCEL

START

Touch the [START] key, then the operation to create the index file will start.



**Do not open the CF card cover during the operation to create the index file. The data may be damaged.**



Too many number of CSV files may cause a time loss for creating the index file. It will take about 10 minutes for creating an index file of the 4,000 CSV files.

If the touch [ESC] key during the operation to create the index file, the operation will stop, then the following screen will appear.

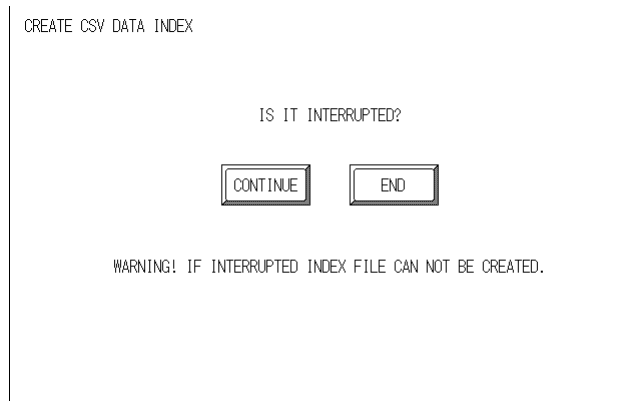

### CONTINUE

The operation restarts. When the message “CREATED INDEX FILE, PLEASE PRESS END KEY” appears, finish the program.

### END

Deletes the creating index file, then the [INITIALIZE MEMORY] screen will reappear.

## 6.7 SET UP TIME

---

Set the GLC unit’s internal clock in the SET UP TIME screen.

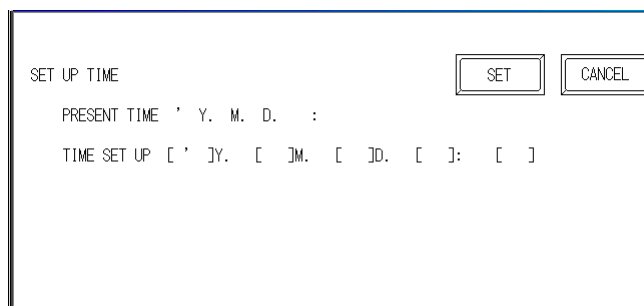

### SET UP TIME

Adjust the date and time display settings in the PRESENT TIME setting item.



- The GLC unit’s internal clock has a slight error in accuracy. At normal operating temperatures and conditions, with the GLC operating from its lithium battery, the degree of error is  $\pm 65$  seconds per month. Variations in operating conditions and battery life can cause this error to vary from -380 to +90 seconds per month. For systems where this degree of error will be a problem, the user should monitor this error and make adjustments as necessary.
- The screen displays the Hour and Minute settings, but not the Seconds.
- Enter the last two digits of the Western calendar year.



### FONT SETTING

Selects the font type displayed on the GLC unit's screen during operation.

### KANJI FONT QUALITY

Designates the font display quality for enlarged characters.

#### Differences in FONT SETTINGS:

##### ◆ When FONT SETTING is set to [JAPAN]

Single-byte characters will remain 8x16-dot characters when they are enlarged.

Double-byte characters are displayed as:

**Standard** Characters are displayed using 16x16-dot "blocks." When enlarged, this font will remain a 16x16-dot character.

**HIGH** When enlarged to double size, Level 1 JIS Kanji Code characters display as 32x32-dot characters. Level 2 JIS Kanji Code characters will remain 16x16-dot characters.

**HIGH (1, 2)** When enlarged to double size, both Level 1 and Level 2 JIS Kanji Code characters display as 32x32-dot characters.

##### ◆ When FONT SETTING is set to any other type, such as [CHINA], [I-ASCII], [KOREA], or [TAIWAN]

**Standard** Half-sized (single-byte) characters display as 16x8-dot characters. Full-size characters, regardless of the display size used, always display as 16x16-dot characters. When enlarged, this font will remain a 16x16-dot character. (Compatible with GP-\*30 Series units)

**HIGH (1)** All half-sized (single-byte) characters — ASCII code: 21h to 7Dh, or alphanumeric characters (except the “ ^ ” and “ ‘ ” characters) — display as high-quality characters.

- 16x16-dot characters or larger display as high-quality 16x16 fonts.
- 32x32-dot characters or larger display as high-quality 32x32 fonts.

Full-sized (double-byte) characters display as 16x16-dot characters, and remain 16x16-dot characters when enlarged.

**HIGH (1, 2)** All single-byte characters — ASCII code: 21h to 7Dh, or alphanumeric characters (except the “ ^ ” and “ ‘ ” characters) — display as high-quality characters.

- When 16x16 dots are used, the characters display as high-quality 16x16-dot characters.
- When 32x32 or larger-sized dots are used, the characters display as high-quality 32x32-dot characters.

Full-sized (double-byte) characters — [KOREA], [TAIWAN], and [CHINA] — display as 32x32-dot characters when enlarged to 32x32-dot characters or larger.

*Memo*

# Chapter

# 7 RUN Mode and Errors

1. GLC RUN Mode
2. SELF-DIAGNOSIS
3. Troubleshooting

4. Error Messages
5. Error Message Details

## 7.1 RUN Mode

The GLC unit enters the RUN mode in two instances: either immediately after plugging in the unit's power cord, or from the GLC unit's OFFLINE mode.

### 7.1.1 After Connecting the Power Cord

The method of GLC startup depends on which "START TIME" setting is specified in the Initialization Settings | System Setup screen.

#### ■ When START TIME is set to "0"

When the GLC unit's power cord is connected, the version information screen appears (see below). The screen designated by the initialization screen file number (within the Initialization Settings | System Setup screen) appears, and then the GLC starts to communicate with the PLC.

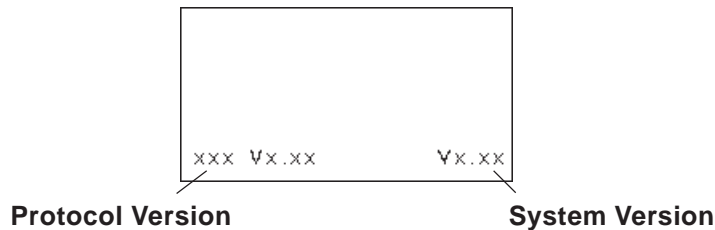

#### ■ When START TIME is set to any value other than "0"

When the GLC unit's power cord is connected, a value appears in the version information screen (below), which counts down the seconds designated by the START TIME setting. The screen designated by the initialization screen file number (within the Initialization Settings | System Setup screen) appears, and then the GLC starts to communicate with the PLC.

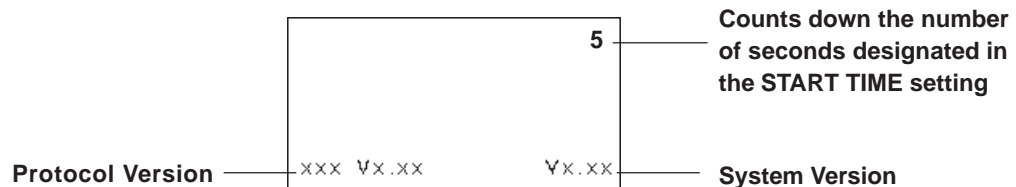

If the initialization screen's file number is not designated, or if a number that does not exist is designated, the version information screen remains displayed.



**Note:** Depending on the display device's startup time, it is possible that the screens shown above may not initially be displayed.



# Chapter 7 – RUN Mode and Errors

## 7.1.2 Via OFFLINE Mode

Touch the MAIN MENU's RUN option to start your downloaded project.

The INITIALIZE menu's SET UP screen designates the screen that initially appears in RUN mode. After this first screen appears, communication with the PLC begins.

If, however, the initial screen has not been created, or does not exist, the version information screen (see previous page) remains displayed.

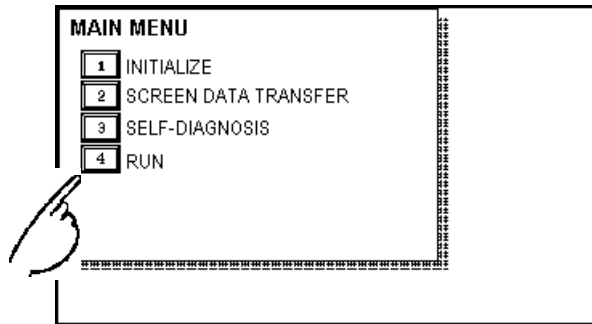

To enter OFFLINE Mode, touch the top left corner of the GLC unit's screen within 10 seconds after connecting the GLC unit's power cord.

After powering up the GLC, the initial screen appears. This screen is equipped with a built-in (invisible) switch in the top left corner that, if touched within 10 seconds, can change the GLC from RUN to OFFLINE mode.

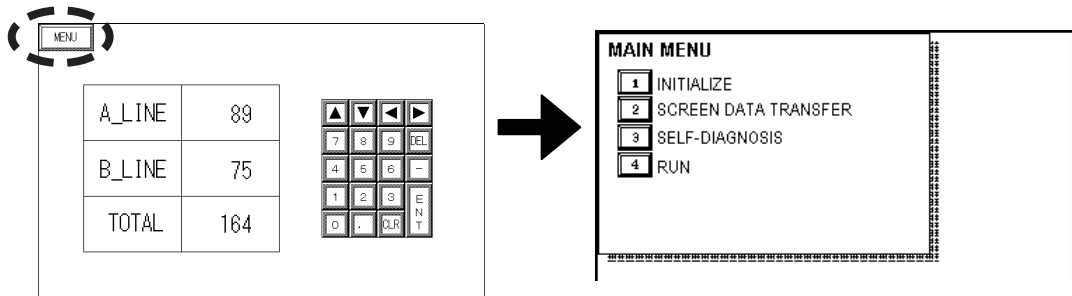

## 7.2 SELF-DIAGNOSIS

The GLC unit is equipped with a number of Self-Diagnosis features used to check its System and Interfaces for any problems.

### 7.2.1 SELF-DIAGNOSIS ITEM LIST

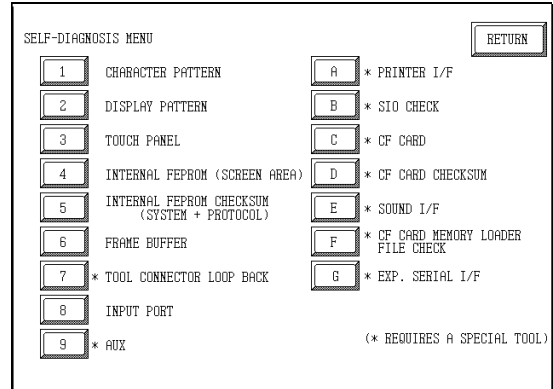
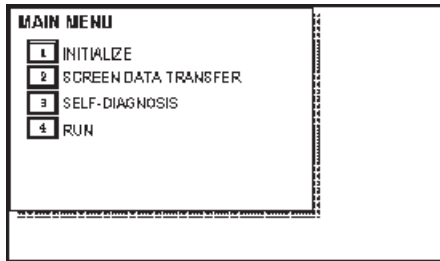

#### 1. CHARACTER PATTERN

Checks the characters inside the internal Character ROM.

#### 2. DISPLAY PATTERN

Checks all the figures and tiling patterns.

#### 3. TOUCH PANEL

Checks each GLC touch panel square.

#### 4. INTERNAL FEPROM (SCREEN AREA)

Checks the internal hard disk contents (FEPROM).

#### 5. INTERNAL FEPROM CHECKSUM (SYSTEM AND PROTOCOL)

Checks the System and Protocol of the GLC Internal Memory (FEPROM).

#### 6. FRAME BUFFER

Checks the internal display memory.

#### 7. TOOL CONNECTOR LOOP BACK<sup>\*1</sup>

Checks the Tool Connector control lines and send/receive lines.

#### 8. INPUT PORT

Checks the Input Port (for Pro-face's maintenance use only).

#### 9. AUX<sup>\*2</sup>

Checks the AUX control line.

#### A. PRINTER I/F<sup>\*1</sup>

Checks the printer interface.

#### B. SIO CHECK<sup>\*1</sup>

Checks the RS-232C and RS-422 send/receive lines.

#### C. CF CARD<sup>\*1</sup>

Checks the status of the CF Card.

#### D. CF CARD CHECKSUM<sup>\*1</sup>

#### E. SOUND I/F<sup>\*1</sup>

Checks the status of the GLC unit's Sound Output feature.

#### F. CF CARD MEMORY LOADER FILE CHECK<sup>\*1</sup>

Checks the status of the CF Card Memory Loader File.

#### G. EXP. SERIAL I/F<sup>\*1</sup>

Checks the status of the Expansion Serial I/F.

1. This item requires that special equipment (cable, connector, etc.) be used.

2. This setting is disabled, since the GLC2000 series does not support this feature.

## Chapter 7 – RUN Mode and Errors

### 7.2.2 SELF-DIAGNOSIS - Details

---

This section explains the contents of SELF-DIAGNOSIS.

**Reference** For information on how to operate the menu interface, see *Chapter 5 – “OFFLINE Mode.”*

For information on how to set up the Special Tools, see *Chapter 3 – “Installation and Wiring.”*

#### 1. CHARACTER PATTERN

Checks each font's pattern and each kanji character's ROM. Used when kanji characters do not display. If no error exists, the message **OK** appears. If an error exists, the message **NG** appears.

#### 2. DISPLAY PATTERN

Checks the drawing function when the buzzer does not sound and when the device contents do not display correctly. Checks are performed on the various screen pattern displays (8 screens), the ON/OFF Display, and the KANJIROM CHECKSUM. When the ON/OFF Display is checked, the Buzzer ON/OFF check is run simultaneously. If KANJIROM CHECKSUM is normal, **OK** displays. If a problem exists, **NG** displays.

#### 3. TOUCH PANEL

Checks that each touch cell lights up when touched.

#### 4. INTERNAL FEPRM (Screen Area)

Checks the internal FEPRM when a screen display error occurs. When using this check menu, you need to enter the password\*1.



- **When you run this check, all screen data that have been created will be deleted. Therefore, be sure to back up data prior to running this check.**
  - **When this check menu is completed, you will need to initialize the internal memory (FEPRM).**
- 

While checking, the following series of screens will display.

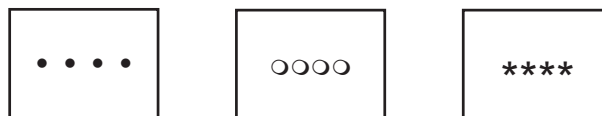

If no error exists, the message **OK** will appear. If an error exists, an error message will appear.

The number of symbol marks (such as “OOOO”) that display on the screen may vary, depending on the GLC type.

- The symbol “O” indicates the GLC is operating the erase check.
- The symbol “\*” indicates the GLC is operating the R/W check.

- 
1. *Enter either the password you have designated in the INITIALIZE screen, or the common password, “1101.”*
-

### 5. INTERNAL FEPRM CHECKSUM (System and Protocol)

The Internal FEPRM System and Protocol check searches for any problems that may occur during operation. When running the check, the screen changes as follows:

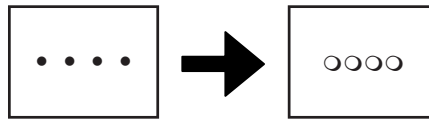

When the FEPRM is normal, **OK** displays. If a problem exists, the screen stops in the middle of operation. This check does not erase the System or Protocol.

### 6. FRAME BUFFER

The Frame Buffer (display memory) Check looks for any display problems that may develop. When everything is normal, **OK** displays. When a problem exists, an error message displays.

### 7. TOOL CONNECTOR

Use the Tool Connector Control line and Send/Receive line check when the GLC cannot send and receive data from the PC. To run the check, it is necessary to connect the pin-side of the Tool Connector Check Loop Back Cable (Dsub9pin) to the GLC unit's Downloading Cable.

When everything is normal, **OK** displays. When a problem exists, an error message displays.

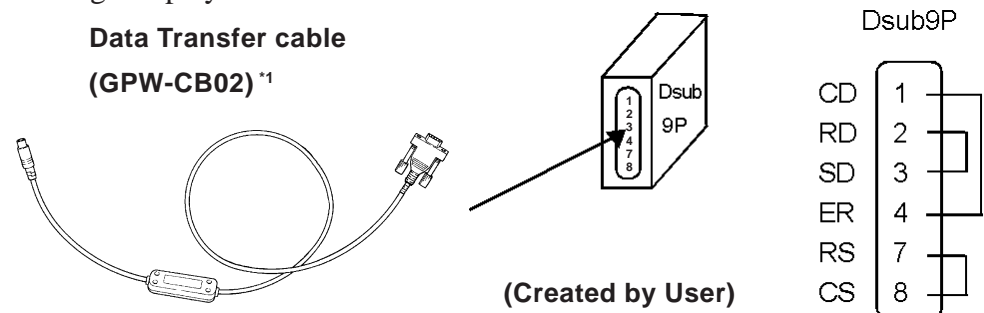

- This Check cannot be performed using the Transfer Cable (GPW-CB03).

### 8. INPUT PORT

Used for Pro-face's maintenance checks only.

### 9. AUX

Because the AUX feature is not loaded in the GLC2000 Series unit, this setting has been disabled.

## Chapter 7 – RUN Mode and Errors

### A. PRINTER I/F

Checks the printer I/F when the printer does not function properly. You need to connect the printer prior to performing this check.

Connecting the printer buffer may cause an error. Therefore, connect the GLC and the printer directly.

If no error exists, (ASCII Code: 20 to 7D<HEX> and A0 to DF<HEX>) will be output (printed) and the message **OK** will appear on the screen. If an error exists, an error message will appear.

### B. SIO CHECK

Checks the RS-232C and RS-422 SIO lines for areas where communication problems develop. In the menu, select which check to run. To run the check, connecting the SIO cable is necessary. If everything is normal, **OK** displays. If a problem exists, an error message appears.

#### SIO cable wiring (RS-232C, RS-422 common)

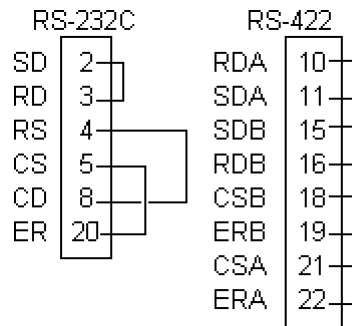

### C. CF CARD

Checks the CF Card's Read/Write feature. Insert the CF Card in the GLC prior to using this check menu. The CF Card needs to have more than 1K bytes of usable space. If no error exists, the message **OK** will appear. If an error exists, an error message will appear.

### D. CF CARD CHECKSUM

Takes the Checksum of the CF Card's files and operates the check. Insert the CF Card in the GLC prior to using this check menu.

This menu checks the following files:

- Filing Data
- CF Card's Image Data
- CF Card's Sound Data

When the check is finished, the following items appear on the screen.

- number of checked files
- number of files that have an error
- file name where the most recent error occurred

## Chapter 7 – RUN Mode and Errors

### E. SOUND I/F

Checks if Sound Output operates. Connect the speaker to the GLC prior to using this check menu. The first three notes of the musical scale (do, re, mi) will sound.

### F. CF CARD MEMORY LOADER FILE CHECK

Checks the CF Card's Memory Loader Tool when it does not start. If no error exists, the message **OK** will appear. If an error exists, the message **NG** will appear.

### G. EXPANSION SERIAL I/F

Checks the Send/Receive line of the Expansion Serial Interface when an abnormality occurs. To run the check, you must connect the SIO cable. If all is normal, the message **OK** appears. If there is a problem, an error message appears.

The SIO cable wiring is as shown below.

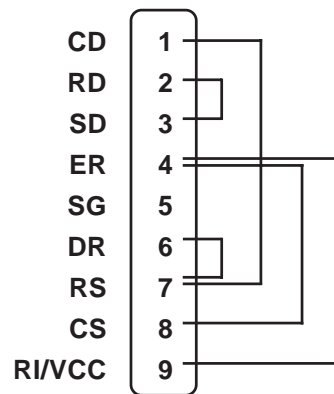

## Chapter 7 – RUN Mode and Errors

### 7.2.3 CONTROLLER SELF-DIAGNOSIS

The Pro-Control Editor or GLC controller setting data is written to non-resident memory. Each of the setting items below is assigned a default value, but, if necessary, make sure that your own settings are entered.

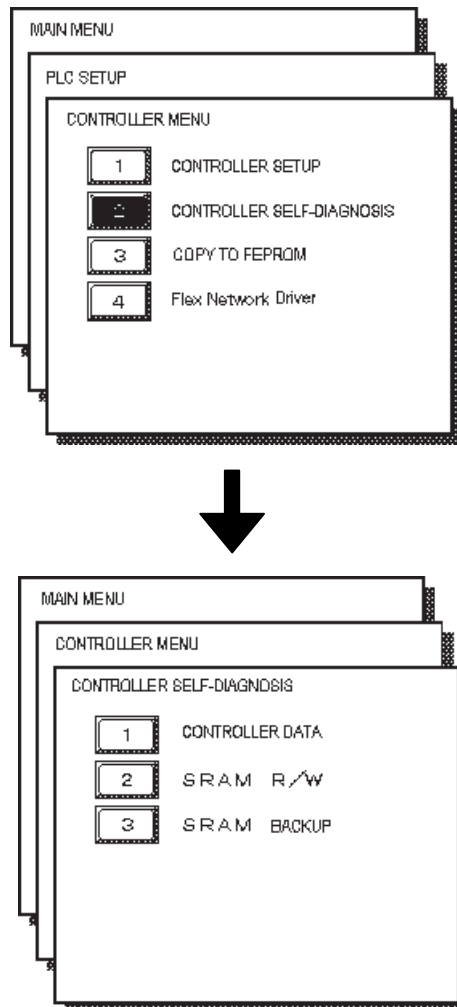

#### CONTROLLER DATA

Shows the current controller version data.

Also, the Memory map setting (Normal or Variable) is displayed.

**Reference** Refer to the *Pro-Control Editor Operation Manual* (included in the GP-PRO/PB III C-Package).

#### SRAM R/W

Performs an SRAM R/W (Read/Write) check. Writes the data required to perform the backup SRAM check.

#### SRAM BACKUP

Before performing this check, be sure to perform the above SRAM R/W check. Then, after turning the GLC unit's power OFF and then ON again, perform the SRAM BACKUP check.



**Performing the above Self-Diagnosis checks will delete all resident SRAM data.**

## 7.3 Troubleshooting

---

This section describes how to find and resolve problems that may occur with the GLC. If a problem exists with the PLC, refer to the corresponding PLC manual.

### 7.3.1 Possible Types of Trouble

---

The following items are problems that may occur while using this unit.

**(A) No Display (Section 7.3.2)**

The screen will not display even when the GLC unit is powered on. Also, during RUN mode, the screen disappears.

**(B) No GLC/HOST Communication (Section 7.3.3)**

The GLC unit cannot extract data from the host. An error message may appear on the screen as a result.

**▼Reference▲** Section 7.4 – “Error Messages”

**(C) Touch Panel Does Not Respond (Section 7.3.4)**

The touch panel does not react when touched, or the reaction time is very slow.

**(D) Cannot Execute Logic Program (Section 7.3.5)**

The GLC freezes, or the control memory’s retentive area does not work.

**(E) Buzzer Sounds when GLC power is turned ON (Section 7.3.6)**

The GLC unit’s buzzer sounds intermittently when the power is first turned ON.

**(E) Clock Setting Cannot be Entered (Section 7.3.7)**

Even after clock setting are entered, the GLC unit’s clock settings remain eg)00/01/01

**▼Reference▲** For problems A to F, see the corresponding flowcharts on Troubleshooting in Sections 7.3.2 to 7.3.7.

**(G) OFFLINE Displays During RUN Mode**

The GLC unexpectedly goes to the OFFLINE mode while operating, or the GLC automatically goes to the OFFLINE mode when the power is turned ON. In this case, a SYSTEM ERROR may have developed while displaying the OFFLINE Mode screen.

**▼Reference▲** Section 7.4.2 – “Error Message Details”

If the GLC goes to the OFFLINE mode without displaying an error message when the power is turned ON, be sure that no object has touched the screen accidentally. Any object that touches the top-left corner of the screen within 10 seconds after the power turns ON may cause the GLC to go OFFLINE.

**▼Reference▲** For other types of Flex Network problems, refer to the *Flex Network User Manual*.



**Note:** The explanations given here assume the origin of the problem is the GLC unit. For host (PLC) related problems, refer to that unit’s Operation Manual.



## Chapter 7 – RUN Mode and Errors

### 7.3.2 No Display

Follow the flowchart below when the screen does not display when powering up, or the screen turns OFF by itself during RUN mode, to find an appropriate solution.

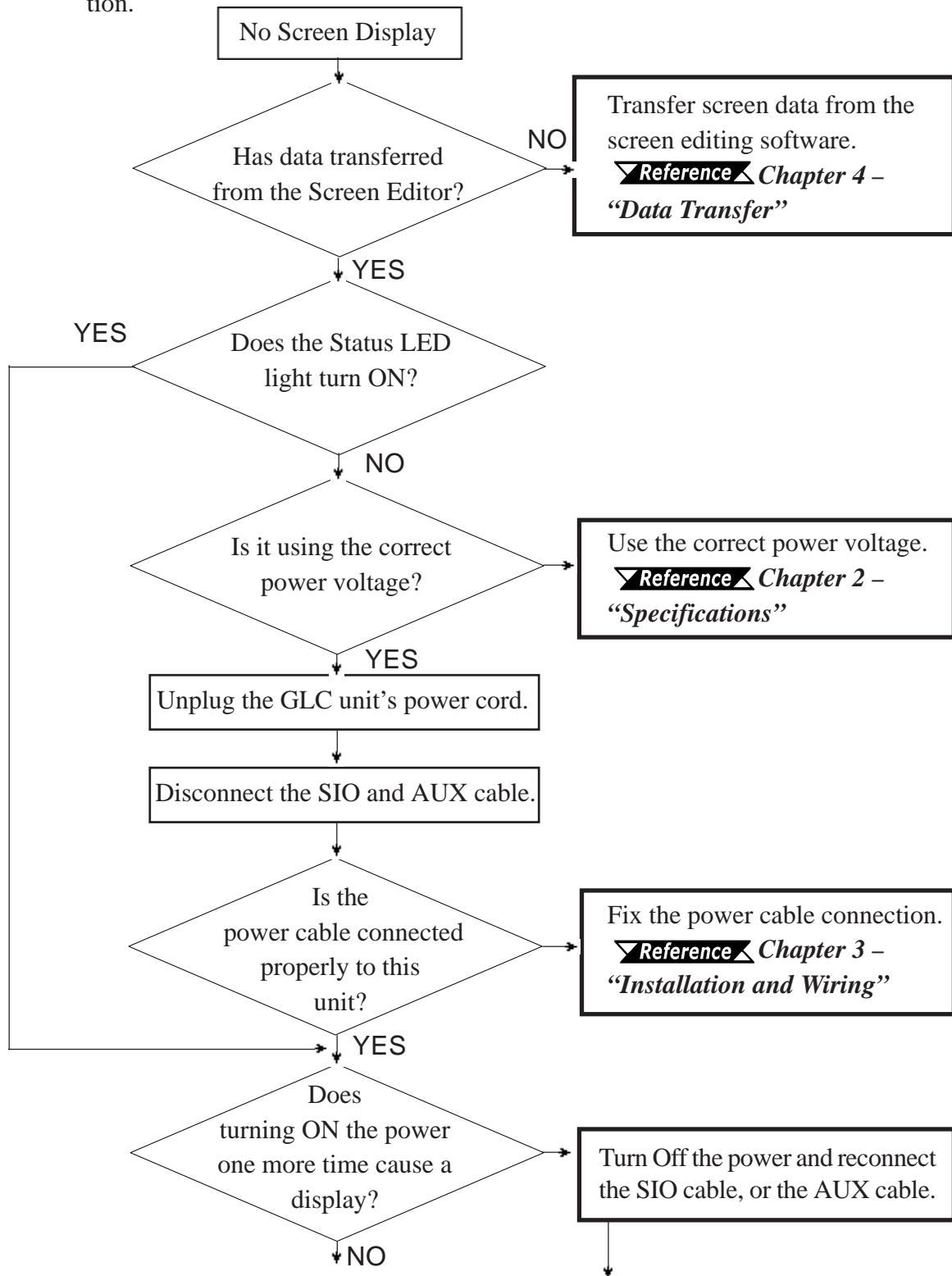

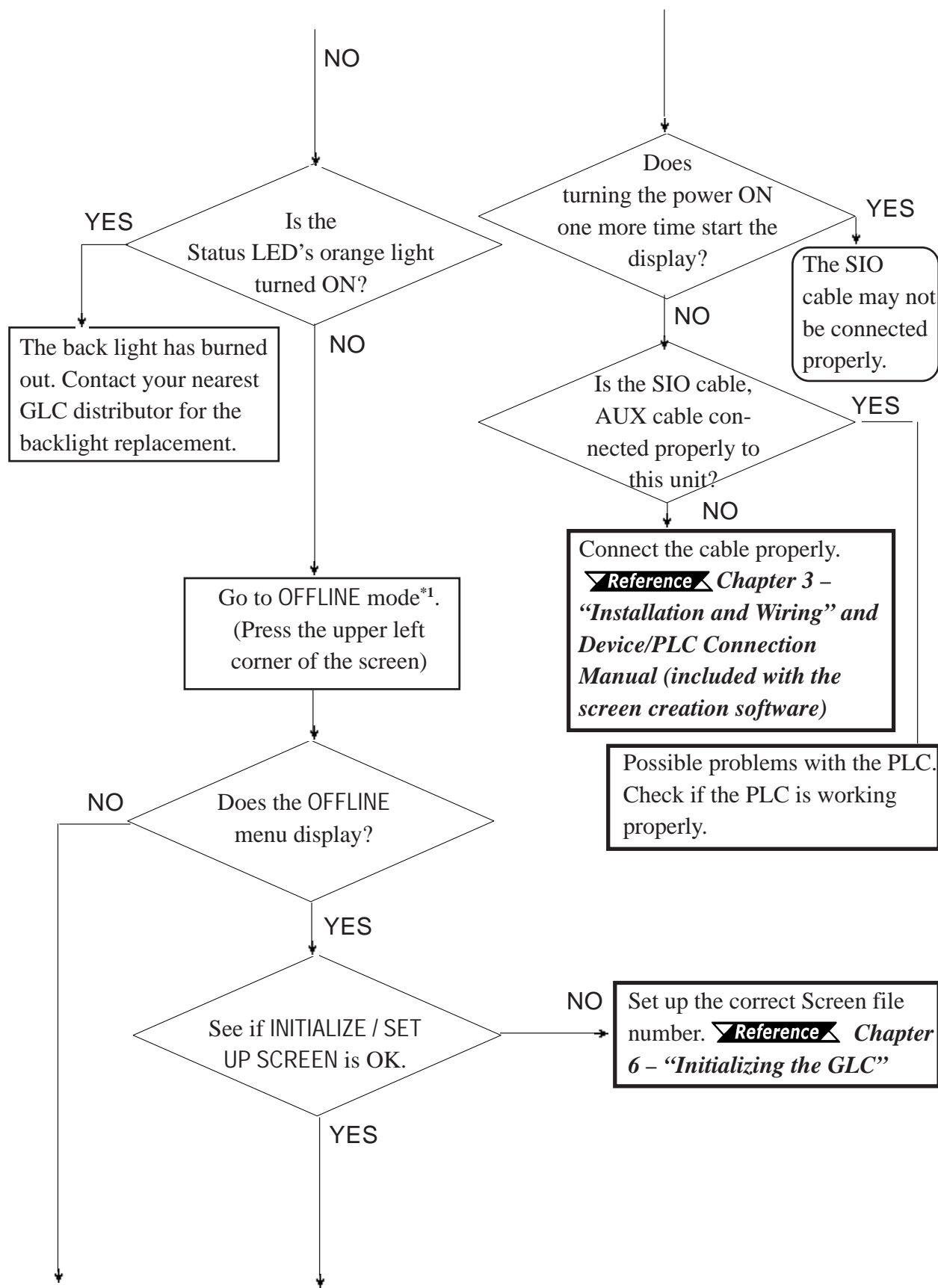

1. To make the OFFLINE screen appear, turn the power OFF, then ON, and press the upper left corner of the screen within 10 seconds.

## Chapter 7 – RUN Mode and Errors

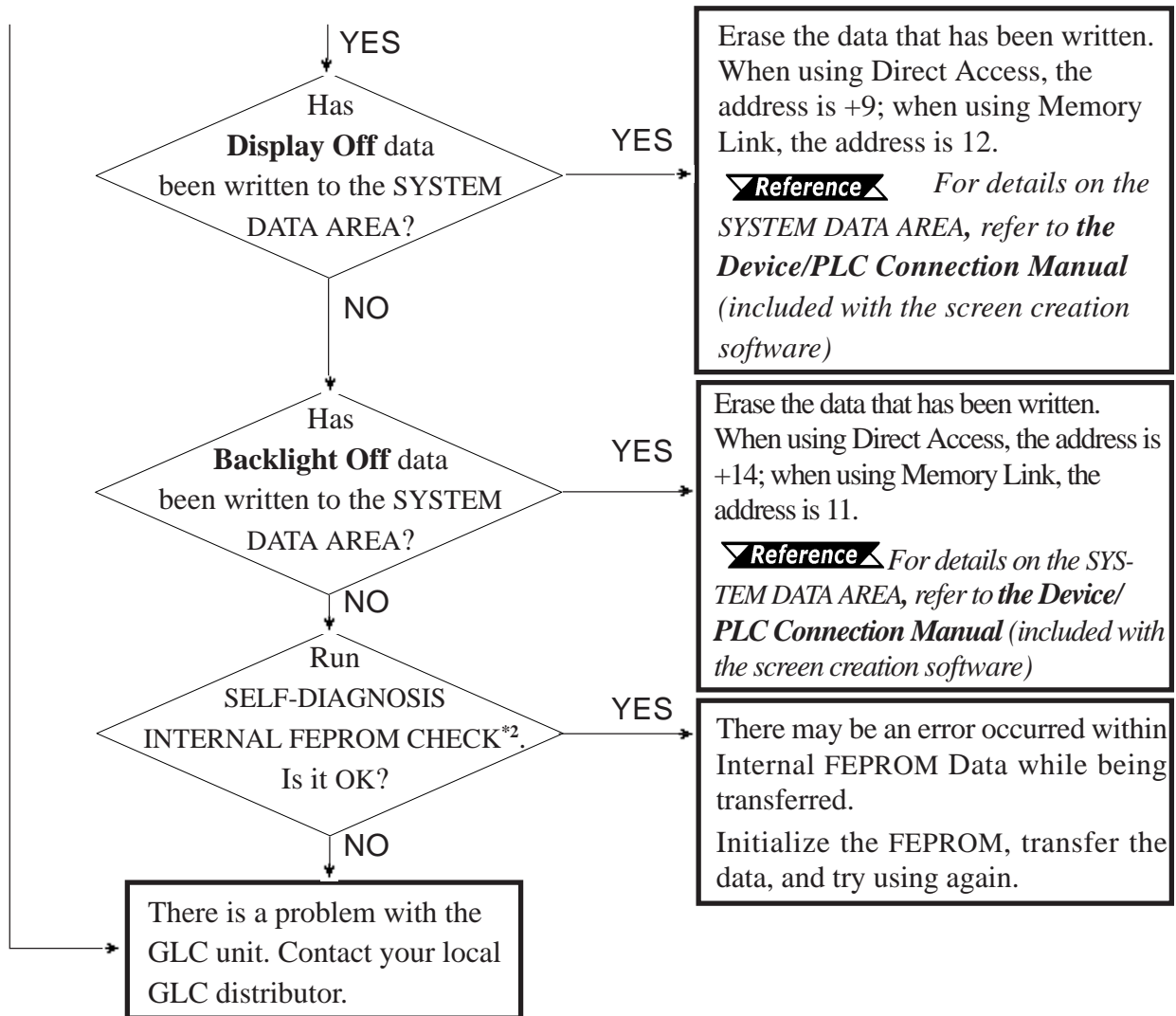

1. When you run the SELF-DIAGNOSIS area's FEPROM CHECK, all screen data is erased. Therefore, be sure to make a backup of all GLC screens prior to performing this check.
2. Also known as "FEEPROM" (Flash Electronic Erasable Programmable Read Only Memory).

## 7.3.3 No GLC/Host Communication

When the GLC will not communicate with the host PLC, follow the flowchart below to find both the cause of the problem and a suitable response.

Or, if an error message displays on the screen, check the error code to find the appropriate solution.

**Reference** Section 7.4 – “Error Messages”

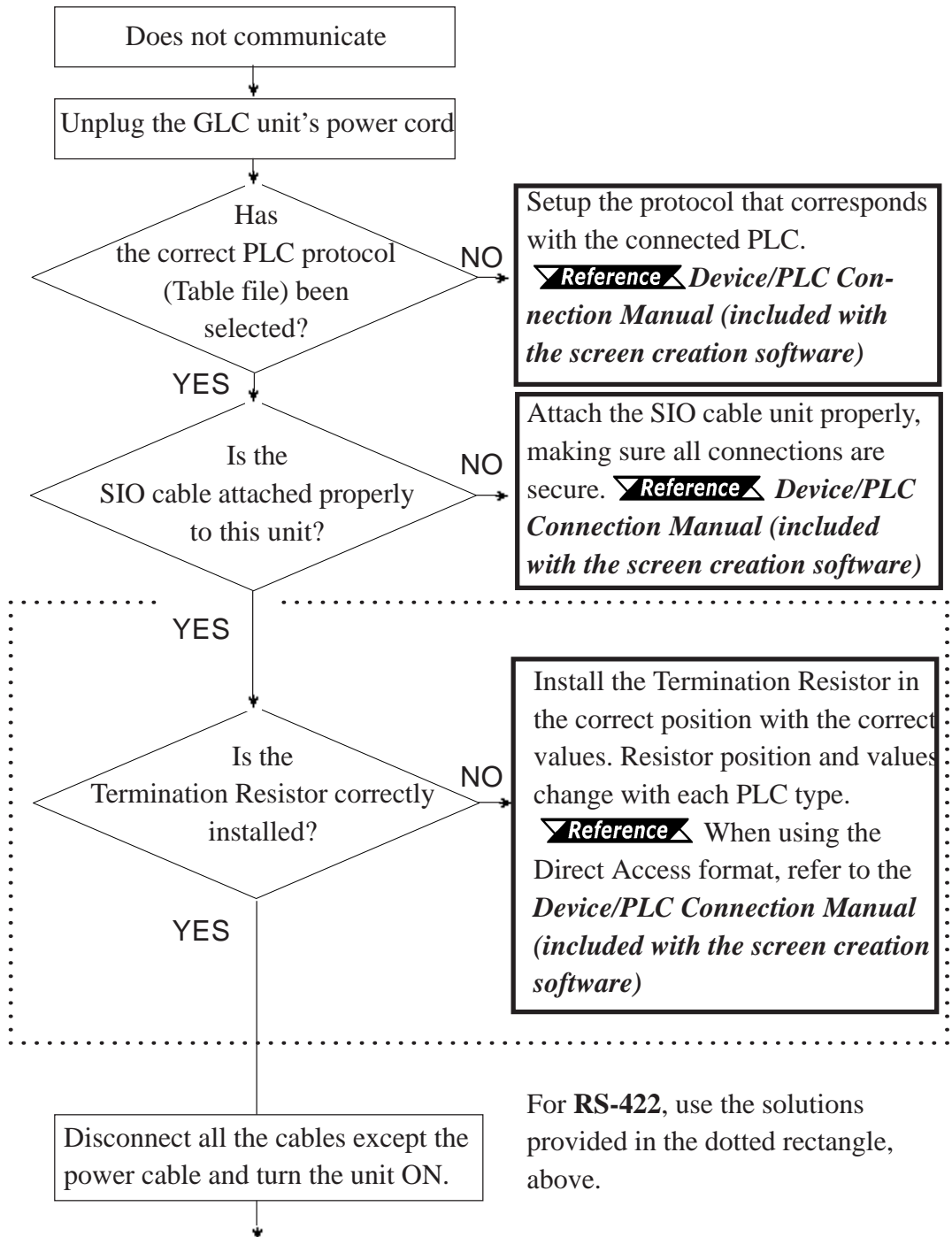

## Chapter 7 – RUN Mode and Errors

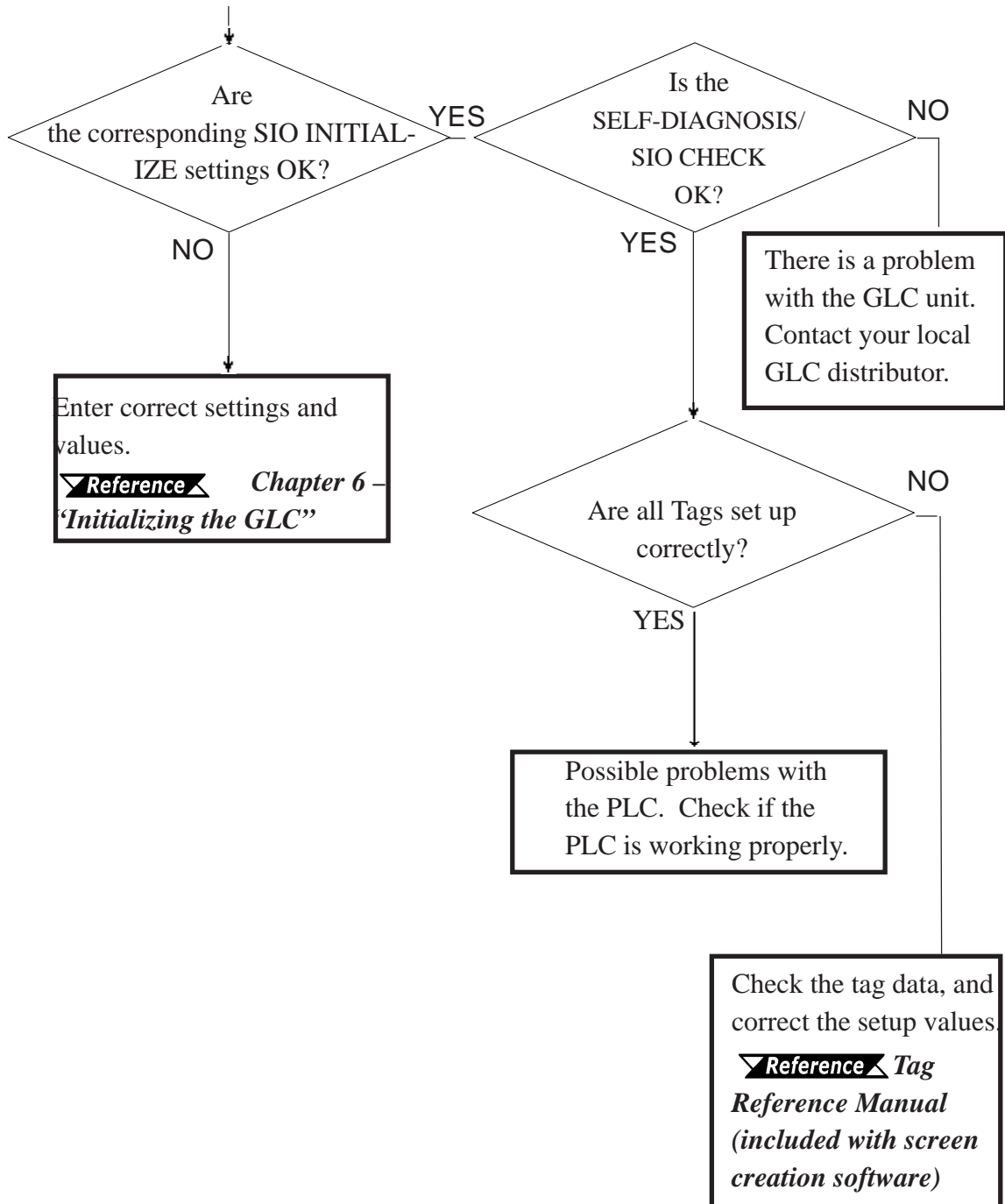

7.3.4 Touch Panel Does Not Respond

When the touch panel does not respond, or its response time is very slow after it is pressed, use the flowchart below to find the origin of the problem, and the appropriate solution.

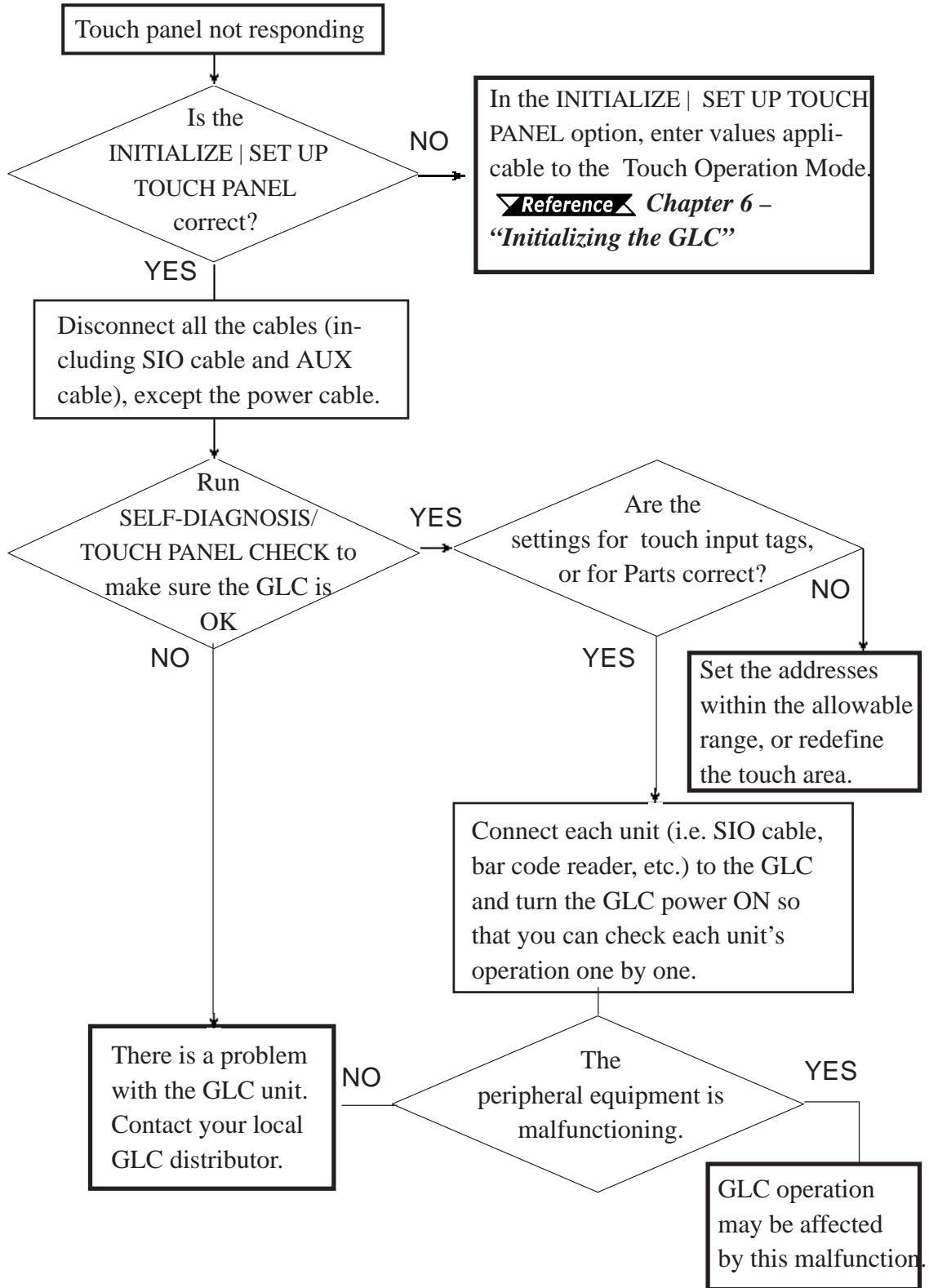

## Chapter 7 – RUN Mode and Errors

### 7.3.5 Cannot Execute Logic Program

Problem	Reason	Solution
Controller Memory's Data Save Area data is not saved after power is turned OFF	Battery Problem	Change the battery.
	Memory Problem	Change the memory unit.
Program error	This is a program data transfer error. The data was not, but should have been, transferred from the data hold area to the RUN area.	Use Pro-Control to restart the control feature. <b>Reference</b> <i>refer to Pro-Control User Manual</i>
	When RUN/STOP switchover is performed, the Hold CLEAR feature is enabled.	Turn this feature OFF.
After changing to RUN mode, control returns to STOP mode	Either a command performance alarm error has occurred, or a major error has occurred.	Debug the program. Check the System variable "#FaultCode".

## Chapter 7 – RUN Mode and Errors

### 7.3.6 Buzzer Sounds when GLC power is turned ON

If you start the GLC unit and the internal buzzer sounds, use the following chart to find the reason and the appropriate solution.

Buzzer Sound	Timing	Reason	Solution
Continuous beep (approx. 1 sec. intervals)	When power to the GLC is turned ON	The GLC unit's system program is destroyed.	From the screen creation software, send the correct system program to the GLC via the Transfer screen's "Forced Setup" feature.
			Turn on the GLC unit's dip switch #1 (next to CF Card slot) and use the CF Memory Loader Tool to set up the GLC.
Two beeps – Repeating (approx. 1 sec. intervals)	When power to the GLC is turned ON	A different GLC unit's system program has been accidentally installed in this GLC.	send the correct system program to the GLC via the Transfer screen's "Forced Setup" feature. An error appears on the Screen Creation Software's screen. Turn the GLC unit's power supply OFF and then ON, and data transfer will start automatically. Turn on the GLC unit's dip switch #1 (next to CF Card slot) and use the CF Memory
Three beeps – Repeating (approx. 1 sec. intervals)	When the GLC unit's dip switch #1 (next to CF Card slot) is ON and power to the GLC is ON.	The CF Card's Memory Loader Tool (MLD****.SYS) file is missing or destroyed.	Reformat the CF Card and replace the CF Card's Memory Loader Tool file.
	When the GLC is started via the Menu Bar's "CF BOOT" key.	The CF Card's Memory Loader Tool (MLD****.SYS) file is missing.	
Four beeps – Repeating (approx. 1 sec. intervals)	When the GLC is started via the Menu Bar's "CF BOOT" key.	The CF Card's internal boot program (IPL.SYS) is destroyed.	Reformat the CF Card and replace the CF Card's Memory Loader Tool file.

If the CF Card's boot-up program (IPL.SYS) or the Memory Loader Tool (MLD\*\*\*\*.SYS) programs appear to be damaged or destroyed, use the GLC unit's internal diagnostic program "CF Card Memory Loader File Check" utility to confirm the condition of these files.

**Reference**  7.2 – "SELF DIAGNOSIS"



## Chapter 7 – RUN Mode and Errors

### 7.3.7 Clock Settings Cannot be Entered

---

This problem occurs when the lithium backup battery's voltage, used for the internal clock, runs out. To enter the clock settings, please read the CLOCK SET UP ERROR directions.

**▼Reference▲** See 7.5.4 – “*CLOCK SET UP ERROR*”

### 7.3.8 Error Screens

---

If the following error screen appears when you start the GLC, it indicates an error has occurred and the GLC is not set up correctly. Be sure to perform screen transfer (Force System Setup) again.

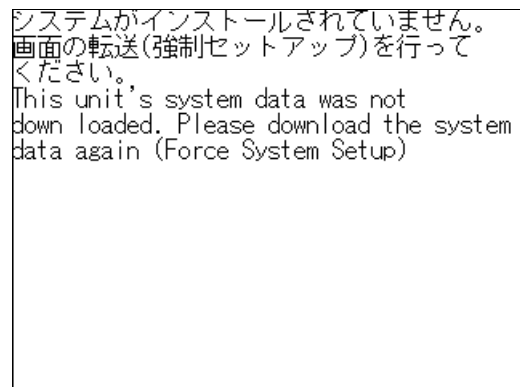



## 7.4 Error Messages

This section explains the messages that appear when an error has occurred in the GLC unit during RUN mode. The problem causing the error message and its related countermeasure are explained in the table below.

After a problem has been solved, unplug the GLC unit's power cord and then reattach it. (*Only the latest error message will appear on the GLC screen*)

### 7.4.1 Error Message List

Error Message	Problem	Countermeasure
<b>SYSTEM ERROR (03 : **)</b>	During screen data transfer, an unrecoverable error occurred.	 <b>Reference</b> 7.5 – "Error Message Details"
<b>SYSTEM ERROR (*** : *** : ***)</b>	During screen data transfer, an unrecoverable error occurred.	 <b>Reference</b> 7.5 – "Error Message Details"
<b>ILLEGAL ADDRESS IN SCREEN DATA</b>	Settings are used that overlap addresses.	Set the addresses correctly after checking the screen data.
<b>UNSUPPORTED TAG IN SCREEN DATA</b>	The GLC currently in use does not support the desired Tag.	Set the Tag correctly after checking the screen data.
<b>PLC NOT CONNECTED (02 : FF) and (02 : F7)</b>	The communication cable is not connected correctly.	Re-connect the communication cable correctly.
<b>PLC NOT RESPONDING (02 : FE)</b>	PLC's power is not turned ON.	Turn ON the PLC's power.
	GLC unit INITIALIZE settings (Setup I/O, PLC Setting) are incorrect.	Check the INITIALIZE settings and make any necessary corrections.
	The host and GLC Powering up sequence was incorrect.	Turn ON the PLC's power and wait for 2-3 seconds, then turn ON the GLC's power.
	The communication cable is not connected properly.	Check the communication cable and connect it correctly.
<b>RECEIVE DATA ERROR (02 : FD)</b>	The communication cable was disconnected while the GLC was ON.	Turn the GLC OFF and then ON again.
	The GLC is powered OFF, then ON during communication with PLC.	Turn the GLC OFF and then ON again.
	Noise occurred in the communication cable.	Check the communication cable and connect it correctly.
<b>GLC STATION NO. DUPLICATION ERROR (02 : F9)</b>	This GLC's station number is same as another GLC.	Check all GLC station numbers, and set them so they are all unique.
	PLC is powered OFF, then ON during communication with GLC.	Turn the GLC OFF and then ON again.

## Chapter 7 – RUN Mode and Errors

<b>NETWORK ADDRESS ERROR (02 : F8)</b>	The SIO address used for this GLC is different from other GLC units. (Only for the multi-link connection)	Check all GLC unit's SIO address settings, and correct any that are incorrect.
<b>PLC COM. ERROR (02:**)</b>	Specific PLC related error, or an error has occurred with the PLC.	<b>Reference</b> See 7.5 – "Error Message Details."
<b>SCREEN MEMORY DATA IS CORRUPT (nnnn:mmmm)</b>	ScreenData is corrupted: *nnnn indicates the Screen Number that has an error. *mmmm indicates the number of screens that have errors.(Decimal)	Check the screens that have errors, correct all errors, and then transfer the screen data again.
<b>CLOCK SETUP ERROR</b>	The backup battery for the internal clock is running low.	<b>Reference</b> See 7.5 – "Error Message Details."
<b>SCREEN TRANSFER ERROR</b>	An error occurred in the data transmission from the screen editor to the GLC panel.	Re-transfer the screen data.
<b>SCREEN TAG LIMIT EXCEEDED</b>	Tags are setup beyond the tag limit (max. of 385)	<b>Reference</b> See 7.5 – "Error Message Details."
<b>OBJ. PLC HAS NOT BEEN SET UP (**)</b>	The host PLC set up in the Editor does not match the PLC in use.	<b>Reference</b> See 7.5 – "Error Message Details."
<b>CF CARD RECOGNITION ERROR</b>	A CF Card that is not compliant with the GLC is being used.	Use an optional CF Card.
	The CF Card is not recognized due to the timing of the CF Card Insertion and Removal.	Either reinsert the CF Card or turn the GLC OFF and then ON again while the CF Card is still inserted.
<b>D-SCRIPT ERROR (***)</b>	D-Script settings (data) are incorrect.	<b>Reference</b> See 7.5 – "Error Message Details."
<b>GLOBAL D-SCRIPT ERROR (***)</b>	Global D-script settings (data) are incorrect.	<b>Reference</b> See 7.5 – "Error Message Details."
<b>EXTENDED SIO SCRIPT ERROR (***)</b>	Extend SIO script settings (data) are incorrect.	<b>Reference</b> See 7.5 – "Error Message Details."
<b>SERIAL I/F CHANGE ERROR</b>	The GP currently in use does not support the "Serial I/F Switch" feature, however in the GP screen editor, "Yes" has been specified for the switch.	<b>Reference</b> See 7.5 – "Error Message Details."

## 7.5 Error Message Details

---

### 7.5.1 System Errors

---

Indicates a fault in the basic operations of the GLC.

Following the error message, an error code, as shown below, will appear. Report the error number and details on how the error developed to your local GLC distributor.

#### ■ SYSTEM ERROR ( 03 : x x )

An unrecoverable error occurred during screen data transfer.

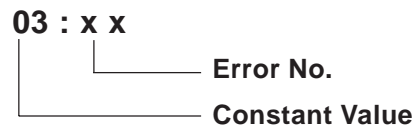

#### ■ SYSTEM ERROR ( x x x : x x x : x x x )

An unrecoverable error occurred during screen data transfer.

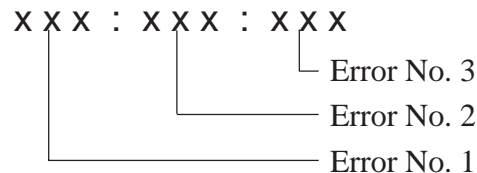

#### Possible Solutions

- Check if the GLC unit's Power Cord and the Input signal line have been wired separately from each other.
- Check that the FG line has been grounded correctly, according to your country's standards.
- Re-send the screen data from the PC to the GLC.
- If other types of communication errors, such as [RECEIVE DATA ERROR], [PLC COM. ERROR], have also occurred, try to correct those problems also.

**Reference** 7.4.1 – "ERROR MESSAGE LIST"

If the above mentioned methods do not solve the problem, contact your local GLC distributor.

## Chapter 7 – RUN Mode and Errors

### ■ When the GLC changes to OFFLINE mode during RUN mode

When the GLC changes to OFFLINE mode without the user first pressing the screen, there is a possibility that the screen data has been damaged. In this case, after the SYSTEM ERROR displays, the screen automatically reverts to OFFLINE mode after about 10 seconds. Run the INITIALIZE MEMORY command and transfer the GLC screen data again from your PC.

In most cases, system errors are related to the problems mentioned below.

### ■ Factors that may cause System Errors

#### Environment Related Problems

If an error occurs which has no apparent connection to the GLC's current operation, the error may be due to the condition of GLC's operating environment. This can include noise or electrostatic interference in the power code or the communication line. In this case you need to check if the power code and the communication line wiring and FG grounding are correct.

#### Screen Data or Project Data Related Problems

If an error seems to be caused by a particular GLC operation, the error may be related to the screen or project data transferred to the GLC. In this case, try sending screen data via the FORCE SYSTEM SETUP feature, which will transfer both the screen data and the project data to the GLC.

**Reference** For details about the FORCE SYSTEM SETUP feature, refer to the "Transfer Settings" section in the *GLC-PRO/PBIII for Windows Operation Manual*.

#### GLC-Related Problems

If disconnecting and then reconnecting the power code corrects an error, the problem may not be related to the GLC unit itself. However, to identify if the GLC unit has any problems, run the OFFLINE mode's SELF-DIAGNOSIS program.

#### Peripheral Equipment-Related Problems (when the GLC is equipped with a printer I/F)

If an error occurs only during printout, there may be a problem with the printer. Check the printer cable wiring and the FG line as well as the printer itself.

#### When a Communication Error Occurs Continuously (when using the Direct Access method)

If a communication error occurs continuously, the GLC may define the error as a system error. In this case you need to solve the problem causing the original communication error.

## 7.5.2 Illegal Address Screen Data

Caused by an overlap of addresses.

After the error message, error codes, as listed below will appear. If the error cannot be fixed, report the error code and details on how the error developed to your local GLC distributor.

ILLEGAL ADDRESS IN SCREEN AREA (00B:XXX:XXX)

### ■ Overlapping Addresses

Error 1	Error 2	Meaning
0C1	191	All or part of the T-tag <sup>*1</sup> or S-tag address range overlap the addresses of System Data Area.
	192	
	193	
0C2	194	All or part of the System Data Area address, A-tag, or S-tag address range overlap the addresses setup in a T-tag. <sup>*1</sup>
	195	
	196	
0C3	197	All or part of a T-tag <sup>*1</sup> , S-tag or K-tag address range overlap the address range set in an A-tag (Alarm Message.)
	198	
	199	
0C9	19B	All or part of a T-tag <sup>*1</sup> , S-tag or K-tag address range overlap the address range set in an A-tag (Log alarm.)



**Note:**

Overlapping addresses, other than the ones mentioned above, can also cause the Illegal Address message.

E.g. When the starting address of the System Data Area is set to 100, and the tag below is set up:

Tag Name/ Part ID No.	Word Address	Tag Format
N1	99	BCD32

Starting from addresses 99, two (2) words are used, which causes it to overlap address 100.

1. For details about the T-tag (trend graph) and A-tag (alarm messages),

**Reference** Refer to the **GLC-PRO/PBIII for Windows Tag Reference Manual** (included with the screen creation software).

## Chapter 7 – RUN Mode and Errors

### 7.5.3 PLC COM. Error

Appears when the address setup for tags exceeds the address range used in the host (PLC.) Check the Error Number that appears and use the following table to solve the problem.

#### PLC COM. ERROR (02 : x x)

└─ Error Code (see table below)

└─ Constant Value

Error #	Problem	Countermeasure
FC	The communication settings for this unit and the host do not match.	For Memory Link type, check the data or settings the host sends. For the PLC communication, check the communication speed.
FB	The address set on a tag, the address used for storing data for Trend graph, or the address set by an alarm message is out of a set range. (address range error)	* When using Memory Link type: Set the addresses within the set range of the System Data Area (0 to 2047), and re-send correct data.
		* When using a Toyoda Machine Works PLC: Set the addresses within the set range of the devices.
		* When using a Yaskawa PLC: Set the addresses within the set range of the devices.
		* When using a Yaskawa PLC: Set the addresses within the set range of the devices.
FA	Address range error	Set the addresses within the allowable range.
53	When using a Matsushita Electronics PLC, and there are too many screen tags, the PLC will not receive data.	Decrease the number of tags on the screen.
51	The tag addresses, Trend graph data storage address, Alarm message Registry address, do not exist in the PLC's internal memory.	* When using a Fuji Electric PLC: Setup the addresses in a device range that exists.
Others	The Error code for each PLC can be found in the table on the last page of this chapter. Then, look up the Error Number in the indicated PLC manual. Or, report the Error Number to the PLC manufacturer.	



**Note:**

With the Hitachi HIDIC H (HIZAC H) Series, the error code is divided into 2 bytes, whereas the GLC Error Number is composed of 1 byte codes.

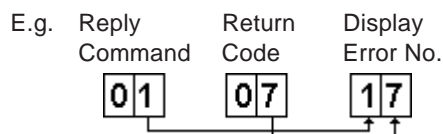

When the Display Error Number is 8\* or 5\*, use only the left column as the error number.



- With the Toshiba PROSEC T Series, the Error Code is 4 characters long. On the GLC, Error Numbers are changed to and displayed in Hexadecimal.
- With the Allen-Bradley PLC-5 and SLC-500 Series, the EXT/STS error codes have been re-mapped to start at D0 HEX, so they will not conflict with other error codes. When looking up the error number in the PLC manual, subtract D0 h from the GLC error code to find its error value.

E.g.	GLC Error Code	—>	PLC Error Code
	D1	—>	01
	EA	—>	1A

### 7.5.4 Clock Set Up Error

---

This message displays when the lithium backup battery’s voltage for the internal clock runs. To reset the error, you need to turn the GLC unit’s power OFF and then ON again. Leave the GLC ON continuously and the battery’s charge will become sufficient for backup after 24 hours, and will be fully charged in approximately 96 hours. If the battery is incorrectly replaced, the battery may explode. To avoid the danger, do NOT replace the battery yourself. When the battery needs a replacement, consult with your local GLC distributor.

After changing the backup battery, set up the internal clock.

**Reference** Chapter 6 – “Initializing the GLC”



The lifetime of the backup battery depends on the ambient temperature and the amount of current being charged and used. The table below gives a general indication of how long the battery will last.

Battery Temperature	40°C or lower	50°C or lower	60°C or lower
Expected Lifetime	10 years or longer	4.1 years or longer	1.5 years or longer

### 7.5.5 Screen Tag Limit Exceeded (max. 384)

---

When tags are setup beyond the tag limit, all tags in excess of number 384 will be disabled. Plus, when tags involve registered Windows and loaded screens, they are disabled in this order: Window Registry, Load Screen.

1. Disabled registered windows start from the last screen used.
2. Disabled loaded screens start from the last screen used.

To correct this problem, reduce the number of tags to within the allowed limit.

### 7.5.6 OBJ. PLC Has Not Been Set Up

---

The host PLC setup in the Editor program (i.e. the .prw file) does not match the PLC in use. Use the Error Code that follows the error message to select the proper PLC type and correct the GLC unit’s INITIALIZE setup data so that it matches this.

OBJ. PLC HAS NOT BEEN SETUP ( x x )

|  
The PLC number (*Hexadecimal*)  
written to the GLC unit’s System  
File.



## Chapter 7 – RUN Mode and Errors

### 7.5.7 D-Script and Global D-Script Errors

---

The following error messages are displayed when D-Scripts and Global D-Scripts are not configured properly. The GLC2400/2500/2600 Series unit displays the error message on the bottom at the GLC screen.

	Error Message
D-Script	D-Script Error (**)
Global D-Script	Global D-Script Error (**)

The following table lists the numbers assigned to (\*\*) in the above error messages. Error Nos. "001" and "002" are displayed at power-on, and Error Nos. "003" and "004" are displayed when an error occurs during the function processing.

No.	Description	Applicable Script
001	The total number of Global D-Scripts exceeds the limit. The maximum number of Global D-Scripts is 32. Note that functions are included in the counts.	Global D-Script
002	The total of all devices in the Global D-Script exceeds the limit of 255 devices.	Global D-Script
003	Either the function being called does not exist, or that function has caused an error.	D-Script Global D-Script
004	Function cannot be nested more than 10 levels.	D-Script Global D-Script

### 7.5.8 Extended SIO Script Error

---

The following error message is displayed when an Extended SIO Script is not configured properly. The GLC2400/2500/2600 Series unit displays the error message on the bottom at the GLC screen.

	Error Message
Extended SIO Script	Extended SIO Script Error (***)

The following table lists the numbers assigned to (\*\*\*) in the above error message. Error No. 001 is displayed at power-on, and Error Nos. 003 and 004 are displayed when an error occurs during the function processing.

No.	Description
001	The total number of the Functions of Extended SIO Scripts exceeds the limit. The maximum number of Functions of Extended SIO Scripts is 254.
002	Reserved
003	The function that is being called does not exist.
004	Functions cannot be nested more than 10 levels.
005	An old Extended SIO Script protocol is being used for the GP system. Extended SIO Script cannot be run when this error occurs. Be sure to install and run a new Extended SIO protocol (Version 1.12 or later).
006	An incompatible function was found in the screen data's Extended SIO Script. Be sure to install and run a new GP system.

## Chapter 7 – RUN Mode and Errors

### 7.5.9 Serial I/F Change Error

---

The following error message is displayed when the GLC currently in use does not support the "Serial I/F Switch" feature, however in the screen editor, "Yes" has been specified for the switch. GLC2400/2500/2600 Series units display the error message at the bottom of the screen.

	Error Message
Serial I/F Change	SERIAL I/F CHANGE ERROR (***)

The following table shows the unit revision<sup>\*1</sup> codes that correspond to the "Serial I/F Switch" function.

Built-in Standard	Product Name	Unit	Corresponding Revision
Serial Interface (Dsub25 Pin)	GLC2400T	GLC2400-TC41-24V	Rev.E and later
	GLC2500T	GLC2500-TC41-200V	All Revisions
GLC2500-TC41-24V			
Expansion Serial Interface (Dsub 9 Pin)	GLC2600T	GLC2600-TC41-200V	Rev.A and later
		GLC2600-TC41-24V	

---

1. For GLC unit revision information, see Revision Version

---

# Chapter 8 Maintenance

1. Regular Cleaning
2. Periodic Check Points
3. Changing the Backlight

## 8.1 Regular Cleaning

---

### 8.1.1 Cleaning the Display

---

When the surface or the frame of the display gets dirty, soak a soft cloth in water with a neutral detergent, wring the cloth tightly, and wipe the display.



- Do NOT use paint thinner, organic solvents, or strong acid compounds to clean the GLC unit.
  - Do NOT use hard or pointed objects to operate the touch-screen panel, since they can damage the panel's surface.
- 

### 8.1.2 Installation Gasket Check / Replacement

---

The installation gasket protects the GLC and improves its water resistance.

**Reference** For instructions on installing the GLC unit's gasket, see *Chapter 3 – "Installation and Wiring."*

---



A gasket which has been used for a long period of time may be scratched or dirty, and may have lost much of its water resistance. Be sure to change the gasket at least once a year, or when scratches or dirt become visible.

---

#### ■ Installation Gasket Attachment Procedure

(The illustration shows the GLC2500T/GLC2600T. However, the procedure for the installation is the same as for the GLC2400T.)

1. Place the GLC on a level surface with the display panel face-down.
2. Remove the gasket from the GLC.
3. Attach the new gasket to the GLC. Be sure to insert the gasket into the GLC's groove so that the gasket's groove sides are vertical.
4. Check if the gasket is attached to the GLC correctly.

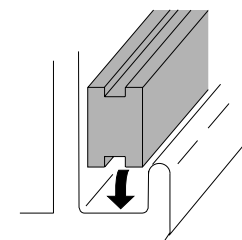
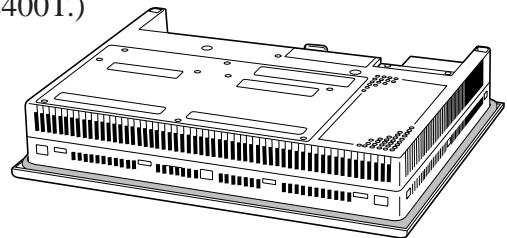



- If the water-resistant gasket is not properly inserted into the groove, the gasket's moisture resistance may not be equivalent to IP65f.
- Be sure the gasket's seam is not inserted into any of the unit's corners, only in the straight sections of the groove. Inserting it into a corner may lead to its eventually tearing.
- To ensure the installation gasket's maximum level of moisture resistance, be sure the gasket's seam is inserted as shown into the panel's bottom face.
- When the water-resistant gasket is properly installed, approximately 2.0 mm of it will extend outside the groove. Before mounting the GLC to the panel, be sure to confirm that the gasket is correctly installed.

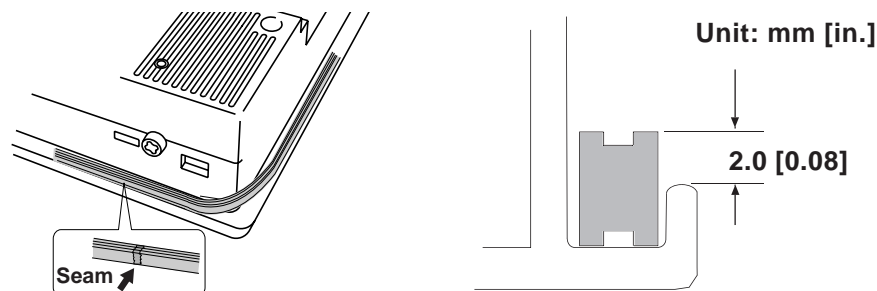

## 8.2 Periodic Check Points

To keep your GLC unit in its best condition, inspect the following points periodically.

### GLC Operation Environment

- Is the operating temperature within the allowable range (0°C to 50°C)?
- Is the operating humidity within the specified range (10%RH to 90%RH, dry bulb temperature of 39°C or less)?
- Is the operating atmosphere free of corrosive gasses?

### Electrical Specifications

- Is the input voltage appropriate?

GLC2500-TC41-200V/GLC2600-TC41-200V : AC85V to 265V

GLC2400-TC41-24V/GLC2500-TC41-24V/GLC2600-TC41-24V : DC 19.2V to DC 28.8V

### Related Items

- Are all power cords and cables connected properly? Have any become loose?
- Are all mounting brackets holding the unit securely?
- Are there many scratches or traces of dirt on the installation gasket?

## 8.3 Replacing the Backlight

---

When the unit's backlight burns out, the unit's status LED will turn orange. If the OFFLINE menu's USE TOUCHPANEL AFTER BACKLIGHT BURNS OUT feature is set to NO, the GLC unit's touch panel will be disabled.\*<sup>1</sup>

**▼Reference▲ 6.4.3 – “SET UP TOUCH PANEL**

GLC2400/2500/2600 Series units use a CFL, long-life type backlight. The actual life of the backlight however, will vary depending on the GLC's operating conditions, and replacement may be required. A GLC2400/2500/2600 Series backlight has a life of 50,000 hours (approx. 5.7 years, at 25°C and 24 hour operation), when the backlight is lit continuously (time required for brightness to fall to half its normal level.)



### WARNINGS

- **To prevent an electric shock, be sure the GLC unit's power cord is unplugged from the power outlet prior to replacing the backlight.**
- **When the power has just been turned OFF, the unit and backlight are still very hot. Be sure to use gloves to prevent burns.**
- **The backlight is very fragile. Do NOT touch the glass tube directly or try to remove its power cord. If the glass tube breaks you may be injured.**

---

*1. If NO has been selected for the OFFLINE menu's FORCE RESET feature, the touch panel operation is disabled.*

**▼Reference▲ 6.4.3 – “SET UP TOUCH PANEL**

---

## Chapter 8 – Maintenance



**Note:**

- Use the following table to check that you have ordered the correct backlight.

GLC Model	Rev.	Backlight Model
GLC2400-TC41-24V	-	PS400-BU00-MS
GLC2500-TC41-24V	-	GP577RT-BL00-MS
GLC2500-TC41-200V	-	
GLC2600-TC41-24V	Rev.3 is marked.* <sup>1</sup>	CA3-BLU12-01
GLC2600-TC41-200V	Rev.4 is marked.* <sup>1</sup>	
GLC2600-TC41-24V	Rev.3 is not marked.* <sup>1</sup>	PS600-BU00
GLC2600-TC41-200V	Rev.4 is not marked.* <sup>1</sup>	

- For backlight replacement details of PS400-BU00-MS, PS600-BU00, GP577RT-BL00-MS, refer to the replacement backlight unit's installation guide.

---

1. The corresponding backlight unit differs depending on GLC2600 Series unit's marked Revision.

**Reference**  For more information on how to determine the revision version, see "Revision Version" (page 17).

---

### 8.3.1 Replacing CA3-BLU12-01

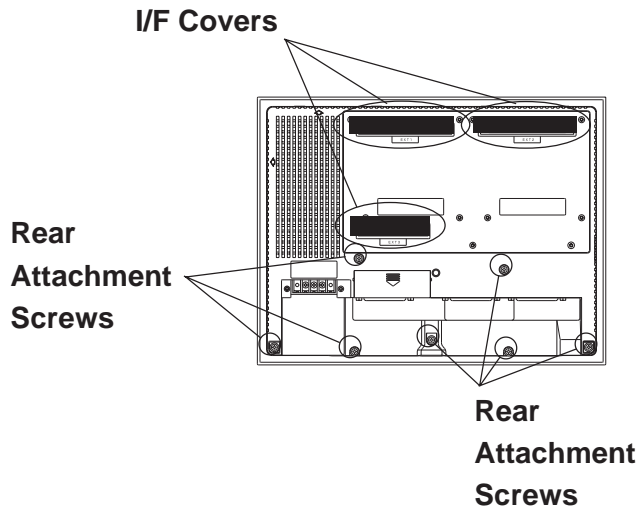

- 1) Turn the GLC's power OFF (i.e. disconnect the GLC's power cord). Remove the three (3) I/F covers, and use a Phillips screwdriver to remove the case's seven (7) rear attachment screws. Pivot the rear cover open, starting from the top of the unit.



*Since the attachment screws are small, be sure not to lose them or allow them to fall inside the GLC's case.*

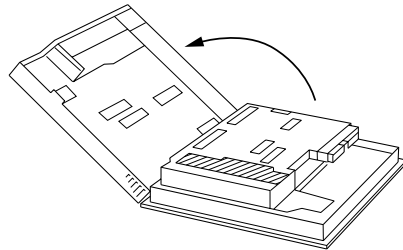

- 2) The cover is fastened at the bottom, and hinges open.



*Be sure not to break the rear cover's four (4) alignment tabs when you open it.*

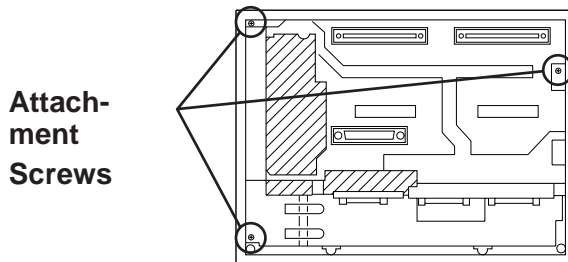

- 3) Loosen the three (3) circuit board attachment screws.

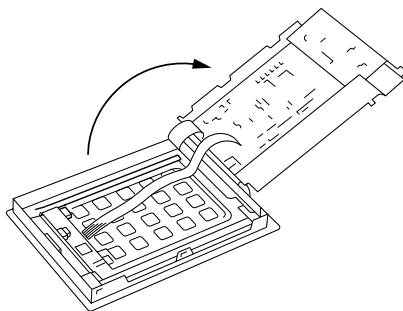

- 4) The circuit board is attached on one side, and hinges open.



*When the GLC's power has just been turned OFF, the circuit board chassis is still very hot! Be sure to wear gloves to prevent being burned.*



## Chapter 8 – Maintenance

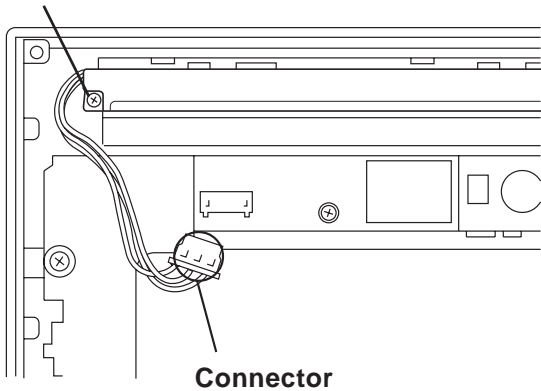

5) Disconnect the backlight's one (1) power connectors.

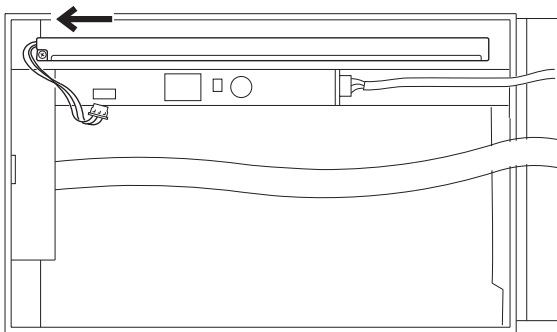

6) Loosen the backlight unit attachment screw. Next, slide the backlight in the direction shown and lift it forward and remove it from the GLC.

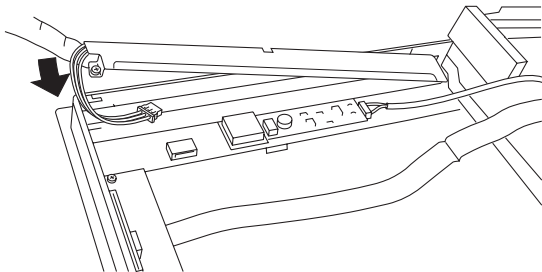

7) Insert the new backlight in the GLC. Insert the unit by sliding it in the direction shown in step 6), then, tighten the unit's attachment screw.

8) Connect the backlight's one (1) power connector. Next, close the circuit board and secure the rear case in place using the attachment screws removed in steps 1), 2) and 3).



- *Be sure not to pinch or cut any of the GLC unit's internal wiring when closing the case.*
- *If any of the attachment screws becomes misplaced, check to be sure that they have not fallen inside the GLC. If a screw has fallen inside the GLC, do not connect the unit's power cord until it has been removed.*

# Index

## Symbol

2 Port Adaptor II .....	1-3
2-D Code Reader .....	1-2

## A

About GLC2000 Series Models .....	14
Accessories .....	1-7
Air Putiry .....	2-2
ALARM MESSAGE .....	6-38
Allowable Voltage Drop .....	2-1
Ambient Operating Temp. ....	2-2
Atmospheric Endurance .....	2-2
Attaching the Installation Gasket .....	3-1
Available Software .....	1-7

## B

B/W REVERSE .....	6-21
Backlight .....	2-3
Backlight Burnout Detection Feature .....	1-18
Bar Code Reader .....	1-2
BLACK / WHITE REVERSE .....	6-12
BRIGHTNESS ADJUSTMENT .....	6-16
Brightness Control .....	2-3
Buck Up Memory .....	2-4
BUZZER ON ERROR .....	6-31
Buzzer Sounds when GLC power is turned ON .....	7-17

## C

Cable Preparation .....	3-18
Cannot Execute Logic Program .....	7-16
CF CARD .....	7-7
CF Card .....	1-2, 1-4, 1-13
CF Card Access LED .....	2-10
CF CARD CHECKSUM .....	7-7
CF Card Cover .....	2-10
CF Card Handling .....	3-17
CF Card Installation and Removal .....	3-15
CF Card Interface .....	2-10
CF CARD MEMORY LOADER FILE CHECK ....	7-7
CF Memory Loader Tool .....	4-6
CHARACTER STRING DATA MODE .....	6-7
CHARACTER STRING DATA SETUP .....	6-7
Checking the IP Address .....	4-5
Cleaning the Display .....	8-1
Clock Accuracy .....	2-4

Clock Set Up Error .....	7-25
Clock Settings Cannot be Entered .....	7-18
Colors .....	2-3
COMMUNICATION FORMAT .....	6-11, 6-19
COMMUNICATION PORT SETUP .....	6-23
COMMUNICATION RATE .....	6-10, 6-18
COMMUNICATION SETUP .....	6-17
Connecting the Power Cord .....	3-6
Connection List .....	6-26
Conneting the Power Supply .....	3-8
CONTRAST ADJUSTMENT .....	6-16
CONTROL .....	6-11
Control Memory .....	2-4
CONTROLLER DATA .....	7-9
CONTROLLER SELF-DIAGNOSIS .....	7-8
Controller Settings .....	6-32
CONTROLLER STATE .....	6-33
Cooling Method .....	2-2
Corrosive Gasses .....	2-2
CSV DATA INDEX .....	6-36
CUSTOMIZE SETUP .....	6-27

## D

D-Script and Global D-Script Errors .....	7-26
DATA FORMAT .....	6-7
DATA LENGTH .....	6-10, 6-18
Data Transfer .....	4-1
Data Transfer Cable .....	1-2
DATA TYPE OF SCREEN NO. ....	6-5
Dimensions .....	2-12
Dip Switches .....	2-11
Display .....	2-3
DISPLAY PATTERN .....	7-5
DISPLAY WARNING .....	6-31
Documentation Conventions .....	18
DOWNLOAD .....	4-8

## E

Effective Display Area .....	2-3
Electrical .....	2-1
Electrostatic Discharge Immunity .....	2-2
Emergency Stop Circuit .....	3-12
Environmental .....	2-2
Error .....	7-1
Error Message Details .....	7-21

# Index

Error Messages .....	7-19	Illegal Address Screen Data .....	7-23
Error Screens .....	7-18	In-Rush Current .....	2-1
Essential Safety Precautions .....	6	INITIALIZATION .....	5-4
Ethernet .....	1-12, 2-5, 2-11	Initialization .....	6-1
ETHERNET SETUP .....	6-29	Initialization Items .....	6-2
Ethernet Cable Connector .....	3-14	INITIALIZE MEMORY .....	6-2, 6-35
Ethernet Data Transfer .....	4-4	INITIALZE CF CARD .....	6-36
EXPANSION SERIAL .....	7-7	INPUT PORT .....	7-5
Expansion Serial .....	7-3	Input Voltage .....	3-12
EXPANSION SERIAL ENVIRONMENT SETUP .....	6-20	Installation Cautins .....	3-11
Expansion Serial Interface .....	1-14, 2-1, 2-5, 2-7, 2-10	Installation Gasket Check / Replacement .....	8-1
EXPANSION SERIAL SETUP .....	6-18	Installation Procedures .....	3-1
Expansion Unit Interface .....	2-10	Installation Slots .....	3-5
Extended SIO Script Error .....	7-27, 7-28	Insullation Resistance .....	2-1
External Dimensions .....	2-2	Interfaces .....	2-5
<b>F</b>		Interlock Circuit .....	3-14
FACILITY .....	6-30	INTERNAL FEPROM (Screen Area) .....	7-5
Flex Network Communication Interface .....	2-5	INTERNAL FEPROM CHECKSUM (System and Protocol) .....	7-5
Flex Network I/F status LED .....	2-11	Introduction .....	1-1
FONT SETTING .....	6-39	<b>K</b>	
FORCE RESET MODE .....	6-15	KANJI FONT QUALITY .....	6-39
FRAME BUFFER .....	7-5	<b>L</b>	
FUNCTION SETUP .....	6-22	Language Fonts .....	2-3
Functional Specifications .....	2-3	Logic Program .....	18
<b>G</b>		<b>M</b>	
GATEWAY .....	6-29	Main Menu .....	5-3
General Safety Precautions .....	12	Maintenance .....	8-1
General Specifications .....	2-1	Memory .....	2-4
GLC .....	1	Menu Bar .....	6-15
GLC2000 Series Overview .....	1-11	MONOPOLIZE TIME .....	6-28
GLC2400T .....	14	MY IP ADDRESS .....	6-29
GLC2500T .....	14	MY PORT NO. ....	6-29
GLC2600T .....	14	<b>N</b>	
GLOBAL WINDOW .....	6-7	n:1 .....	6-1
GLOBAL WINDOW ACCESS .....	6-7	NETWORK INFORMATION ADDRESS .....	6-26
GLOBAL WINDOWS SETUP .....	6-6	nitial Start Mode .....	4-2
GP TOUCH MONOPOLIZE .....	6-28	No Display .....	7-10
Grounding .....	2-2, 3-10	No GLC/Host Communication .....	7-13
<b>H</b>		Noise Immunity .....	2-2
HOST IP ADDRESS .....	6-30	<b>O</b>	
<b>I</b>		OBJ. PLC Has Not Been Set Up .....	7-25
I/O Signal Line Cautions .....	3-11	OFFLINE Mode .....	5-1

ONLINE ERROR DISPLAY ..... 6-38  
 Operating Humidity ..... 2-2  
 Operation Altitude ..... 2-2  
 OTHERS SETUP ..... 6-31  
 OUTPUT LEVEL ..... 6-30

**P**

Package Contents ..... 14  
 Panel Cut ..... 3-3  
 Panel Cut Dimensions ..... 2-14  
 PARITY ..... 6-10, 6-18  
 Part Names ..... 2-9  
 PASSWORD SETUP ..... 6-5  
 PERCENT ALLOCATION ..... 6-33  
 Periodic Check Points ..... 8-2  
 PLC COM. Error ..... 7-24  
 PLC PRIORITY ..... 6-27  
 PLC SETUP ..... 6-2, 6-24  
 Pollution Degree ..... 2-2  
 Possible Types of Trouble ..... 7-9  
 Power Consumption ..... 2-1  
 Power Input Terminal Block ..... 2-10  
 Power Interruption ..... 3-12  
 PRINTER I/F ..... 7-7  
 Prior to Operating the GLC ..... 1-1  
 Pro-Control Editor ..... 18

**Q**

QUALITY ..... 6-21

**R**

Rated Voltage ..... 2-1  
 Rated Voltage Range ..... 2-1  
 Ratings ..... 2-2  
 RECEIVE TIMEOUT ..... 6-18  
 Recommended Units ..... 1-7  
 REGISTRATION NO. .... 6-7  
 Replacing the Backlight ..... 8-3  
 RESET GP ON DATA WRITE ERROR ..... 6-24  
 Resolution ..... 2-3, 2-4  
 RETRY COUNT ..... 6-18  
 RI / VCC ..... 6-19, 6-23  
 RS-232C Cable ..... 1-3  
 RS-422 Cable ..... 1-3  
 RS-422 Connector Terminal Adapter ..... 1-3  
 RUN ..... 5-3, 7-1

**S**

Scan Time ..... 6-33  
 SCANNING MODE ..... 6-24  
 SCREEN DATA TRANSFER ..... 5-3  
 Screen Editor ..... 18  
 Screen Tag Limit Exceeded ..... 7-25  
 Screw Lock Terminal Block ..... 2-10  
 SELF-DIAGNOSIS ..... 5-6, 6-31, 7-3  
 SELF-DIAGNOSIS ITEM LIST ..... 7-3  
 Serial Data Transfer ..... 4-1  
 SERIAL I/F CHANGE ..... 6-23  
 Serial I/F Change Error ..... 7-28  
 Serial Interface ..... 2-5, 2-6, 2-10  
 SET UP I/O ..... 6-2, 6-10  
 SET UP PRINTER ..... 6-12  
 SET UP SCREEN ..... 6-2, 6-38  
 SET UP SIO ..... 6-10  
 SET UP TIME ..... 6-2, 6-37  
 SET UP TOUCH PANEL ..... 6-15  
 setup ..... 4-3  
 SETUP CAPTURE OPERATION ..... 6-21  
 Shock Resistance ..... 2-2  
 SIO CHECK ..... 7-7  
 Specifications ..... 2-1  
 SRAM Back Up ..... 2-4  
 SRAM BACKUP ..... 7-9  
 SRAM R/W ..... 7-9  
 STAND-BY MODE TIME ..... 6-3  
 START TIME ..... 6-3  
 STARTING ADDRESS OF  
     SYSTEM DATA AREA ..... 6-24  
 STATION NO. .... 6-26  
 STATION SETUP ..... 6-25  
 STOP BIT ..... 6-10, 6-18  
 STOP ON MINOR FAULT ..... 6-33  
 Storage Humidity ..... 2-2  
 Storage Temperature ..... 2-2  
 Structural ..... 2-2  
 SUBNET MASK ..... 6-29  
 SYSTEM AREA READING AREA SIZE ..... 6-24  
 SYSTEM AREA SETUP ..... 6-4  
 System Area Size ..... 6-4  
 System Design ..... 1-2  
 SYSTEM ENVIRONMENT SETUP ..... 6-2  
 System Environment Setup ..... 6-3  
 System Error ..... 7-21  
 SYSTEM SETUP ..... 6-3

# Index

## T

Table of Contents .....	2
TARGET SCAN TIME .....	6-33
Text .....	2-3
TOOL CONNECTOR .....	7-5
Tool Connector .....	2-5, 2-10, 3-14
TOUCH BUZZER SOUND .....	6-3
TOUCH OPERATION MODE .....	6-15
TOUCH PANEL .....	7-5
Touch Panel Does Not Respond .....	7-15
Troubleshooting .....	7-9

## U

UNIT NO. ....	6-24
UPLOAD .....	4-8
USE TOUCH PANEL AFTER BACKLIGHT BURNOUT .....	6-16

## V

Validation List .....	6-26
Vibration Resistance .....	2-2
Voltage Endurance .....	2-1

## W

WATCHDOG TIMER .....	6-33
Weight .....	2-2
WINDOW LOCATION .....	6-7
Wiring Cautions .....	3-6