

Digital
Human Machine Interface ———

Pro-face

Flex Network User Manual

Digital
Digital Electronics Corporation

Preface

Thank you for purchasing Pro-face's Flex Network units, hereafter referred to as the "Unit".

The Unit is designed to be used with Pro-face's Graphic Logic Controller or Pro-face's LogiTouch Series units (hereafter referred to collectively as the "GLC") for distributed I/O connection.

This manual explains the overall features and specifications of the Unit, as well as its installation procedures.

Please be sure to read this manual thoroughly to understand the correct and safe usage of this product and its features.

<Note>

- 1) It is forbidden to copy the contents of this manual, in whole or in part, except for the user's personal use, without the express permission of Digital Electronics Corporation of Japan.
- 2) The information provided in this manual is subject to change without notice.
- 3) This manual has been written with care and attention to detail; however, should you find any errors or omissions, please contact Digital Electronics Corporation and inform us of your findings.
- 4) Please be aware that Digital shall not be held liable by the user for any damages, losses, or third party claims arising from the uses of this product.

All Company/Manufacturer names used in this manual are the registered trademarks of those companies.

© 2001, Digital Electronics Corporation

Flex Network® is a registered trademark of Digital Electronics Corporation in Japan and other countries.

Table of Contents

Preface	1
Table of Contents	2
Essential Safety Precautions	4
General Precautions	6
Documentation Conventions	7
Flex Network Unit Models	7
Compatible GLC Units	8
UL/c-UL(CSA) Approval	9
CE Marking.....	11

CHAPTER 1 INTRODUCTION

1.1 System Design	1-1
1.2 Flex Network Unit Types	1-3

CHAPTER 2 SPECIFICATIONS

2.1 General Specifications	2-1
2.1.1 Electrical	2-1
2.1.2 Environmental	2-2
2.1.3 Structural	2-3
2.2 Performance Specifications	2-4
2.2.1 Data Transfer Settings	2-4
2.2.2 Flex Network I/O Unit Input/Output	2-4
2.3 Input/Output Circuit Drawings	2-10
2.4 Part Names and Features	2-17
2.4.1 Flex Network I/F Unit	2-17
2.4.2 Flex Network I/O Unit	2-18
2.5 Dimensions	2-21
2.5.1 Flex Network I/F Unit	2-21
2.5.2 Flex Network I/O Unit	2-23

CHAPTER 3 INSTALLATION AND WIRING

3.1 Installation	3-1
3.1.1 Flex Network I/F Unit Installation	3-1
3.1.2 I/O Unit Installation/Removal	3-2
3.1.3 Attaching a 32-Point I/O Unit	3-4

3.2 Wiring 3-5
3.2.1 Connecting the Flex Network Data Transfer Cable 3-5
3.2.2 Connecting the Power Cord 3-8
3.2.3 Connecting the I/O Cable 3-9
3.2.4 General Cautions 3-11

CHAPTER 4 PROBLEMS AND SOLUTIONS

4.1 Problem Solving 4-1
4.1.1 Prior to Troubleshooting 4-1
4.1.2 Error Code Display 4-2
4.1.3 Troubleshooting 4-3

INDEX

Essential Safety Precautions

This guide contains a variety of safety markings for safe and correct operation of this Unit. Please read this installation guide and any related manuals carefully to fully understand how to correctly use this Unit's functions.

■ Safety Symbols

Please pay attention to these symbols and follow all instructions given.

The safety symbols and their meanings are as follows:



Indicates situations where severe bodily injury, death or major machine damage will definitely occur.



Indicates situations where severe bodily injury, death or major machine damage can possibly occur.



Indicates situations where slight bodily injury or machine damage can occur.

DANGERS

- **An emergency stop circuit and an interlock circuit should be constructed outside of this Unit. Constructing these circuits inside a system that uses this Unit may cause a runaway situation, system failure, or an accident due to unit failure.**
- **Systems using this Unit should be designed so that output signals which could cause a serious accident are monitored from outside the Unit.**
- **This Unit is designed to be a general-purpose device for general industries, and is neither designed nor produced to be used with equipment or systems in potentially life-threatening conditions. If you are considering using this Unit for special uses, including nuclear power control devices, electric power devices, aerospace equipment, medical life support equipment, or transportation vehicles, please contact your local Pro-face distributor.**



WARNINGS

- Prior to installing, removing, wiring, and conducting maintenance or inspections, be sure to disconnect power to this Unit to prevent an electric shock or fire.
- Do not disassemble or remodel this Unit, since it may lead to an electric shock or fire.
- Do not use this Unit in an environment that contains flammable gases since an explosion may occur.
- Do not use this Unit in an environment that is not specified in either the Installation Guide or User Manual. Otherwise, an electric shock, fire, malfunction or other failure may occur.
- Due to the possibility of an electric shock or malfunction, do not touch this Unit's power terminals it is operating.



CAUTIONS

- Communication cables or I/O signal lines must be wired separately from the main circuit (high-voltage, large-current) line, high-frequency lines such as inverter and power lines. Otherwise, a malfunction may occur due to noise.
- This Unit must be installed according to directions given in its Installation Guide and User manual. Improper installation may cause the Unit to malfunction or fail.
- This Unit must be wired according to directions in the Installation Guide and User Manual. Improper wiring may cause a malfunction, failure or electric shock.
- Do not allow foreign substances, including chips, wire pieces, water, or liquids to enter inside this Unit's case. Otherwise, a malfunction, failure, electric shock, or fire may occur.
- When disposing of this Unit, it should be processed according to your country's industrial waste disposal laws.



General Precautions

■ To Prevent Unit Damage

- Avoid storing or operating this Unit in either direct sunlight or excessively dusty or dirty environments.
- Because this Unit is a precision instrument, do not store or use it in locations where excessive shocks or vibration may occur.
- Avoid covering this Unit's ventilation holes, or operating it in an environment that may cause it to overheat.
- Avoid operating this Unit in locations where sudden temperature changes can cause condensation to form inside the Unit.
- Do not use paint thinner or organic solvents to clean this Unit.

Documentation Conventions

The list below describes the documentation conventions used in this manual.

Symbol	Meaning
	Indicates important information or procedures that must be followed for correct and risk-free software/device operation.
*1	Indicates useful or important supplemental information.
1) , 2)	Indicates steps in a procedure. Be sure to perform these steps in the order given.
	Refers to useful or important supplemental information.
	Provides useful or important supplemental information.
Pro-Control Editor	Indicates the Pro-Control Editor ladder logic development software.
1:N	Indicates a multi-link type connection is used.
GLC	Generic name for the "GLC Series" of Graphic Logic Controllers made by Digital Electronic Corporation. In this manual, it also indicates "LogiTouch" Series units".

Flex Network Unit Models

Flex Network Units allow the GLC to communicate via a Flex Network system. The available Flex Network Unit model numbers are shown below.

System Name	Unit Name	Model No.	Rating	Memo	
Flex Network Unit	Flex Network I/F Unit *1	GLC100-FN11	Standard Unit	-	
		GLC100-FN41	UL/c-UL(CSA) Approved, CE Marked Unit	-	
	Flex Network I/O Unit	FN-X16T S11	Standard Unit	8/16 Points	
		FN-X16T S41	UL/c-UL(CSA) Approved, CE Marked Unit		
		FN-XY08T S11	Standard Unit		
		FN-XY08T S41	UL/c-UL(CSA) Approved, CE Marked Unit		
		FN-Y08RL11	Standard Unit		
		FN-Y08RL41	UL/c-UL(CSA) Approved, CE Marked Unit		
		FN-Y16SK41			
		FN-Y16SC41			
		FN-Y32T S41	UL/c-UL(CSA) Approved, CE Marked Unit		32 Points
		FN-XY16SK41			
	FN-XY16SC41				

*1 The Flex Network I/F Unit (GLC100-FN11/GLC100-FN41) is compatible with all GLC100 Series and GLC300 Series units. It is not required for GLC2000 Series, or LogiTouch Series units.

Compatible GLC Units

The following GLC units can be used with the Flex Network I/O and I/F units.

General Name	Series Name	Unit Name	Model No.	Memo	
GLC	GLC100 Series	GLC100L	GLC100-LG41-24V	Requires Flex Network I/F Unit	
		GLC100S	GLC100-SC41-24V		
	GLC300 Series	GLC300S	GLC300-TC41-24V	Requires Flex Network I/F Unit and Bus Conversion Unit	
	GLC2000 Series ^{*1}	GLC2300 Series	GLC2300L	GLC2300-LG41-24V	
			GLC2300T	GLC2300-TC41-24V	
		GLC2400 Series	GLC2400T	GLC2400-TC41-24V	
		GLC2600 Series	GLC2600T	GLC2600-TC41-24V	
	LogiTouch Series ^{*1*2}	LogiTouch Type-B		GLC150-BG41-FLEX-24V	
		LogiTouch Type-C		GLC150-BG41-RSFL-24V	

**1 The 32 Point Flex Network I/O Unit (FN-X32TS41/FN-XY16SK41/FN-XY16SC41) is compatible with all GLC2000 Series and LogiTouch Series units.*

**2 The LogiTouch Type A* unit is not compatible with the Flex Network.*

UL/c-UL(CSA) Approval

■ Flex Network I/F Unit

The GLC100-FN41 is a UL/c-UL(CSA) listed product. (UL file No.E182139)

This unit conforms to the following standards:

◆ **UL508**

Industrial Control Equipment

◆ **UL1604**

For use with Electrical Equipment in Class I and II, Division 2 and Class III Hazardous (Classified) Locations in industrial control applications.

◆ **CAN/CSA-C22.2, No. 1010-1**

Safety requirements for electrical equipment for measurement and laboratory use.

GLC100-FN41 (UL Registration Model: 2880063-01)

<Cautions>

- The GLC must be used as a built-in component of an end-use product.
- This unit is designed to be attached to a GLC100 Series or GLC300 Series unit.
- If the GLC is installed so as to cool itself naturally, be sure to install it in a vertical panel. Also, be sure that the GLC is mounted at least 100 mm away from any adjacent structures or equipment. If these requirements are not met, the heat generated by the GLC's internal components may cause the unit to fail to meet UL/c-UL standard requirements.

UL1604 Conditions of Acceptability and Handling Cautions:

1. Power, input and output (I/O) wiring must be in accordance with Class I, Division 2 wiring methods - Article 501- 4(b) of the National Electrical Code, NFPA 70 within the United States, and in accordance with Section 18-152 of the Canadian Electrical Code for units installed within Canada.
2. Suitable for use in Class I, Division 2, Groups A, B, C and D, Hazardous Locations.
3. **WARNING:** Explosion hazard - substitution of components may impair suitability for Class I, Division 2.
4. **WARNING:** Explosion hazard - when in hazardous locations, turn power OFF before replacing or wiring modules.
5. **WARNING:** Explosion hazard - do not disconnect equipment unless power has been switched OFF, or the area is known to be non-hazardous.

■ Flex Network I/O Units

The following Flex Network units are UL/c-UL (CSA) approved.

- FN-X16TS41 (UL File No. E 195835)
- FN-XY08TS41 (UL File No. E 195835)
- FN-Y08RL41 (UL File No. E 195835)
- FN-Y16SK41 (UL File No. E 195835)
- FN-Y16SC41 (UL File No. E 195835)
- FN-X32TS41 (UL File No. E 220851)
- FN-XY16SK41 (UL File No. E 220851)
- FN-XYL16SC41 (UL File No. E 220851)

These Units conform to the following standards:

◆ UL508

Industrial Control Equipment

◆ CAN/CSA-C22.2, No. 1010-1

Safety requirements for electrical equipment for measurement and laboratory use.

FN-X16TS41 (UL Registration Model: 2880063-02)

FN-XY08TS41 (UL Registration Model: 2880063-03)

FN-Y08RL41 (UL Registration Model: 2880063-04)

FN-Y16SK41 (UL Registration Model: 2880063-05)

FN-Y16SC41 (UL Registration Model: 2880063-06)

FN-X32TS41 (UL Registration Model: 3080039-01)

FN-XY16SK41 (UL Registration Model: 3080039-02)

FN-XY16SC41 (UL Registration Model: 3080039-03)

<Cautions>

- This Unit must be used as a built-in component of an end-use product.
- If this Unit is installed so as to cool itself naturally, be sure to install it on a vertical DIN rail or to a vertical panel via attachment holes. Also, be sure that this Unit is mounted at least 100 mm away from any adjacent structures or equipment. If these requirements are not met, the heat generated by this Unit's internal components may cause the Unit to fail to meet UL/c-UL standard requirements.
- Any power supply device connected to the Unit should be a UL/c-UL(CSA) approved Class 2 power supply or Class 2 transformer. *1

Single unit power supplies, when connected to this Unit, multiple I/O units or when driving a load, should be designed so that the total power consumption of the I/O unit(s) and the total load current meets the standards for a Class 2 power supply, or a Class 2 power transformer.

Also, be aware that the number of load producing points, and the load current value will determine the number of output points that can be simultaneously turned ON.

*1 Class 2 power supplies and Class 2 transformers should not exceed an output of 30V, and at 8A or less, should not exceed 100V.

CE Marking

■ Flex Network I/F Unit

The GLC100-FN41 is a CE marked product that conforms to EMC directives EN55011 Class A and EN61000-6-2 (EN50082-2).

<Cautions>

Even though the GLC meets the abovementioned EMC standards, if it is installed into another piece of machinery, that machinery's installation, wiring or positioning method(s) used may cause the GLC to fail to meet the designated EMC standard. Therefore, the combination of the GLC and this machinery may need to be re-tested, as a final, complete unit.

** For detailed CE marking information, please contact your local Pro-face distributor.*

■ Flex Network I/O Units

The following Flex Network Units are CE marked products that conform to EMC directives EN55011 Class A and EN61000-6-2.

[Compatible Units]

FN-X16TS41, FN-XY08TS41, FN-Y08RL41, FN-Y16SK41,
FN-Y16SC41, FN-X32TS41, FN-XY16SK41, FN-XY16SC41

** For detailed CE marking information, please contact your local Pro-face distributor.*

Memo



Chapter

1 Introduction

1. System Design
2. Flex Network Unit Types

This chapter explains the standard system design for the Flex Network unit, and the types of units available.

1.1 System Design

The following information explains how to connect the GLC to a Flex Network I/F and I/O Unit.

When connecting the I/O unit, 2 channels are available - CH1 and CH2. Each channel outputs the same data and either can be used for data transmission.

The maximum number of connectable units, when using a single channel, is 31, and when using a second channel, the number increases by 32 to a total of 63.



- **The Flex Network uses high speed data transfer technology, and if a cable is used for data transfer that is not the same as that specified in this document, network data transfer performance cannot be guaranteed. Thus, be sure to use only the cable(s) recommended here.**

Reference 3.2.1 Connecting the Flex Network Data Transfer Cable

- **When connecting the Flex Network I/F unit to a GLC 300 Series operator interface, the optional Bus Conversion unit is required. (Model No. GLC300-BCB41).**
- **When turning the entire system's power ON, turn on the I/O unit's power supply before turning on the GLC's power.**

■ With One (1) Channel

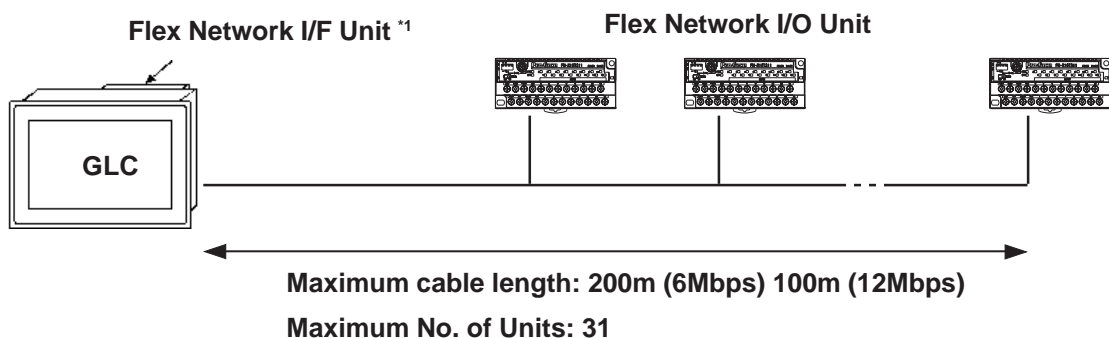

*1 GLC2000 Series/LogiTouch Series do not require the Flex Network I/F Unit.

■ With Two (2) Channels

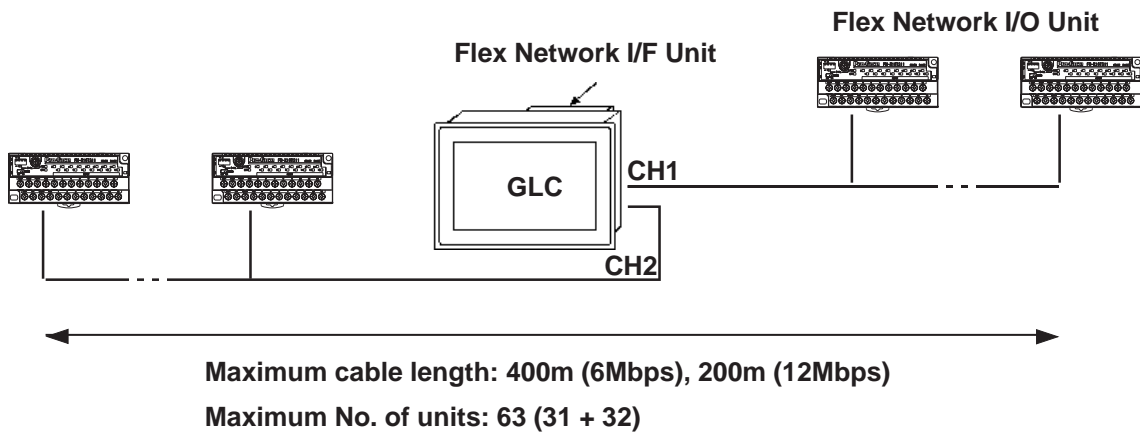

Note: When using two channels, up to 32 nodes can be connected to either channel.

■ Standard System Design

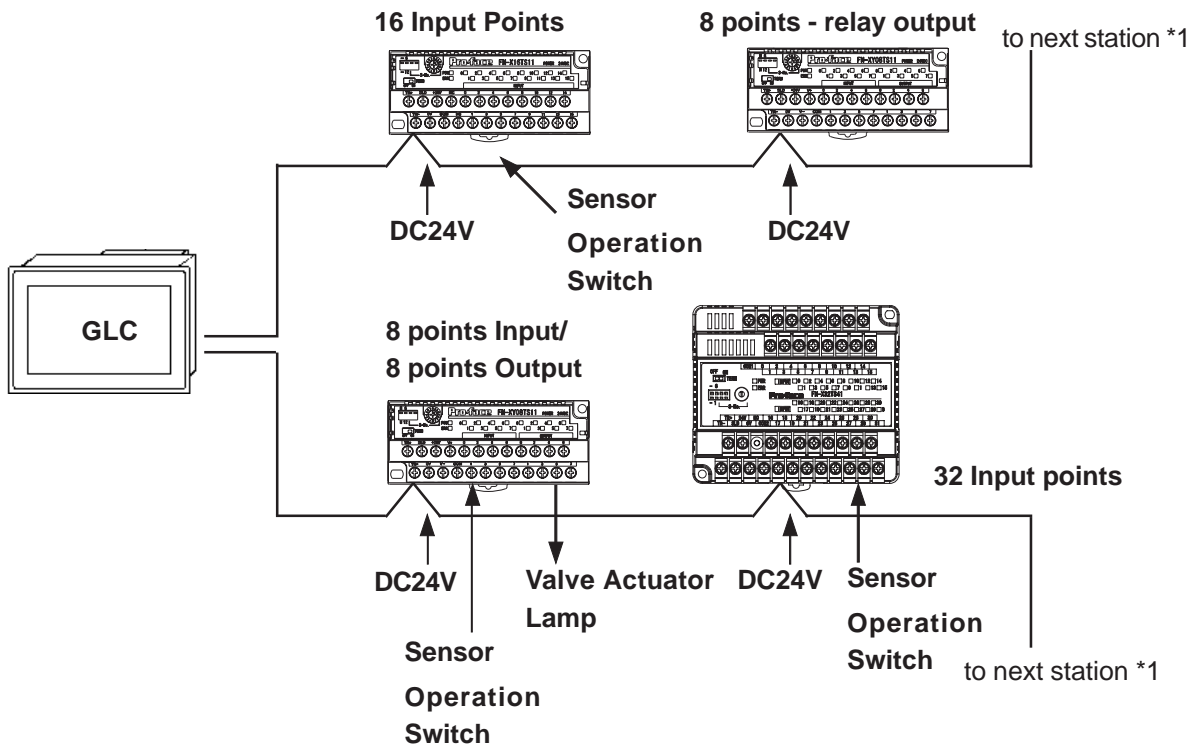

Note: 6Mbps is the recommended speed.

*1 Be sure the Terminal Switch (TERM) of the network's last unit (at each end) is turned ON.

Reference 2.4.2 Flex Network I/O Unit

1.2 Flex Network Unit Types

The following tables explain the different types of Flex Network units. These are optional GLC units and are sold separately.

■ Expansion Units

◆ I/F Unit

Item	Model No.	Description
Flex Network I/F Unit	GLC100-FN11 GLC100-FN41	Attached to rear of GLC100 or GLC300 series units to allow data transfer over a Flex Network. Not required for GLC2000 Series /LogiTouch Series units. GLC300 Series units require the separately sold Bus Conversion Unit.

◆ I/O Units

Item	Model No.	Description
Flex Network 16-point Input Sink-Source type I/O Unit	FN-X16TS11 FN-X16TS41	16-point sink-source type shared I/O Unit. Sink-source can be selected by wiring between the input circuit and common (COM terminal) cabling.
Flex Network 8-pt Input Sink-Source / 8-pt Transistor Output Sink type I/O Unit	FN-XY08TS11 FN-XY08TS41	I/O Unit with combination of 8-pt sink-source inputs and 8-pt transistor sink outputs. Can be connected to DC24V, 200mA electromagnetic bulb, or pilot lamp for output.
Flex Network 8-pt Relay Output / 1 Common type I/O Unit	FN-Y08RL11 FN-Y08RL41	8-point relay output / 1 common type I/O unit. Can be connected to AC240V (1A load).
Flex Network 16-point Output Sink type I/O Unit	FN-Y16SK41	16-point sink output I/O unit
Flex Network 16-pt Output Source type I/O Unit	FN-Y16SC41	16-point source output I/O unit.
Flex Network 32-point Input Sink-Source type I/O Unit	FN-X32TS41	32-point sink-source type shared I/O Unit. Sink-source can be selected by wiring between the input circuit and common (COM terminal) cabling.
Flex Network 16-pt Input Sink-Source /16-pt Transistor Output Sink type I/O Unit	FN-XY16SK41	I/O Unit with combination of 16-pt sink-source inputs and 16-pt transistor sink outputs. Can be connected to DC24V, 200mA electromagnetic bulb, or pilot lamp for output.
Flex Network 16-pt Input Sink-Source/16-pt Transistor Output Source type I/O Unit	FN-XY16SC41	I/O Unit with combination of 16-pt sink-source inputs and 16-pt transistor source outputs. Can be connected to DC24V, 200mA electromagnetic bulb, or pilot lamp for output.

◆ **Analog Unit**

Item	Model No.	Description
Flex Network 4-Channel Analog/Digital Conversion Input Unit	FN-AD04AH11	Stores analog signal in this unit after converting it to 12-bit digital signal.
Flex Network 4-Channel Analog/Digital Conversion Output Unit	FN-DA04AH11	Converts 12-bit digital signal to analog signal and sends output.

◆ **Single Axis Positioning Unit**

Item	Model No.	Description
Flex Network Single-Axis Positioning Unit	FN-PC10SK41	Controls a servo motor and stepping motor. Handles up to 2MHz.

◆ **High-Speed Counter Unit**

Item	Model No.	Description
Flex Network High-Speed Counter Unit	FN-HC10SK41	Maximum speed is 200Kpps. Can be used in combination with positioning units and work rate counters to perform cutting applications, due to the simultaneous output and programmable cam switch features.

◆ **Optional Expansion Unit**

Item	Model No.	Description
Bus Conversion Unit	GLC300-BCB41	This unit is attached to the rear of the GLC300 Series. It must be attached before the Flex Network I/F (GLC100-FN11/ GLC100-FN41) unit is attached to the GLC300 Series unit.

◆ **Optional Items**

Item	Model No.	Description
Single-Axis Teaching Loader	FN-PC10LD41	Program-input unit for the Flex Network single-axis positioning unit. Used for parameter entry, as well as positioning check and movement.(includes one piece of FN-LD10CBL.)
Single-Axis Motor Driver Connection Cable	FN-PC10CB01 (1m)	Connects the Flex Network single-axis positioning unit and the servo and stepping drivers.
Flex Network Communication Cable	FN-CABLE 2010-31-MS (10m)	Connects distributed Flex Network units.
	FN-CABLE 2050-31-MS (50m)	
	FN-CABLE 2200-31-MS (200m)	

◆ **Maintenance Items**

Item	Model No.	Description
Single-Axis Teaching Loader Cable	FN-LD10CBL (5m)	Connects the Flex Network single-axis positioning unit and the single-axis teaching loader.

Chapter 2 Specifications

1. General Specifications
2. Functional Specifications
3. I/O Circuit Connection Drawings
4. Part Names and Features
5. Dimensions

The Flex Network I/F Unit (GLC100-FN11/GLC100-FN41) is compatible with all GLC100 Series and GLC300 Series units. It is not required for GLC2000 Series/LogiTouch Series Units.

Reference *GLC2000 Series User Manual/LogiTouch Series User Manual*

2.1 General Specifications

2.1.1 Electrical

■ Flex Network I/F Unit

Rated Voltage	DC5V +/-5% (supplied from GLC)
Power Consumption	1.25W or less
Voltage Endurance	AC1500V 10mA for 1min. (between external charging and FG terminals)
Insulation Resistance	DC500V at 10M Ω or higher (between external charging and FG terminals)

■ Flex Network I/O Unit (Control Section)

	FN-X16TS11/FN-X16TS41 FN-XY08TS11/FN-XY08TS41 FN-Y16SK41/FN-Y16SC41	FN-Y08RL11 FN-Y08RL41	FN-X32TS41 FN-XY16SK41 FN-XY16SC41
Rated Voltage	DC24V		
Rated Voltage Range	DC20.4V to DC28.8V		
Allowable Voltage Interruption	10ms or less (Power Supply: DC24V)		
Power Consumption	1.5W or less	1W or less	2.5W or less
Voltage Endurance	AC1500V 10mA for 1min. (between power/Input and Output, and FG terminals)		AC500V 10mA for 1 min. (between power/ Input and Output, and FG terminals)
Insulation Resistance	DC500V at 10M Ω or higher (between power/Input and Output, and FG terminals)		
In-rush Current	30A or less		

2.1.2 Environmental

■ Flex Network I/F Unit

Operating Temperature	0°C to 50°C (cannot be higher than GLC unit)
Storage Temperature	-20°C to +60°C
Operating Humidity	20%RH to 85%RH (non-condensing)
Storage Humidity	20%RH to 85%RH (non-condensing)
Air Purity (Dust)	0.1mg/m ³ or less (non-conductive levels)
Corrosive Gasses	Free of corrosive gasses
Vibration Endurance	10Hz to 25Hz 19.6m/s ² (in X,Y,Z directions for 30min. each)
Noise Immunity (via noise simulator)	Noise Duration: 1000Vp-p Pulse Duration: 1μs Rise Time: 1ns
Electrostatic Discharge Immunity	GLC100-FN11: 4kV (contact discharge) GLC100-FN41: 6kV (IEC61000-4-2, RH-1/ESD-3)

■ Flex Network I/O Unit

	FN-X16TS11/FN-X16TS41 FN-XY08TS11/FN-XY08TS41 FN-Y16SK41 FN-Y16SC41 FN-Y08RL11/FN-Y08RL41	FN-X32TS41 FN-XY16SK41 FN-XY16SC41
Operating Temperature	0°C to 55°C	
Storage Temperature	-25°C to +70°C	
Operating Humidity	5%RH to 95%RH (non-condensing) (wet bulb temperature: less than 39°C)	
Storage Humidity	5%RH to 95%RH (non-condensing) (wet bulb temperature: less than 39°C)	
Air Purity (Dust)	0.1mg/m ³ or less (non-conductive levels)	
Corrosive Gasses	Free of corrosive gasses	
Vibration Endurance	5Hz to 55Hz 60m/s ² (in X,Y,Z directions for 2 hours each)	IEC61131-2 (JIS B 3501) compliant When vibration IS NOT continuous: 10Hz to 57Hz 0.075mm, 57Hz to 150Hz 9.8m/s ² When vibration IS continuous: 10Hz to 57Hz 0.035mm, 57Hz to 150Hz 4.9m/s ² X,Y,Z directions for 10 times (80 min.)
Shock Endurance	300m/s ² (for 10ms in X,Y, Z directions - 3 times each)	IEC61131-2 (JIS B 3501) compliant 147 m/s ² (for 11ms in X, Y, Z directions - 2 times each)
Noise Immunity (via noise simulator)	Noise Voltage: 1000Vp-p, Pulse Duration: 1μs, Rise Time: 1ns	
Electrostatic Discharge Immunity	6kV (IEC61000-4-2, RH-1/ESD-3)	

2.1.3 Structural

■ Flex Network I/F Unit

Cooling Method	Natural air circulation
Weight	350g or less
External Dimensions	W 111mm [4.37in.] x H 120mm [4.72in.] x D 31.5mm [1.24in.] (Main unit only, not including connector)

■ Flex Network I/O Unit

	FN-X16TS11/FN-X16TS41 FN-XY08TS11/FN-XY08TS41 FN-Y16SK41 FN-Y16SC41 FN-Y08RL11/FN-Y08RL41	FN-X32TS41 FN-XY16SK41 FN-XY16SC41
Attachment Method	via 35mm DIN rail or by attachment screws	
Cooling Method	Natural air circulation	
Weight	150g or less	350g or less
External Dimensions	W 108mm [4.25in.] x H 45mm [1.77in.] x D 49mm [1.93in.]	W 110mm [4.33in.] x H 95mm [3.74in.] x D 57mm [2.24in.]
Rating	IP20	

2.2 Performance Specifications

2.2.1 Data Transfer Settings

Communication Type	1:N
Connection Method	Multi Drop
Transfer Distance	At 6Mbps 200m per CH, at 12Mbps 100m per CH
Transfer Method	During cyclic period, distributed transmission, Half-duplex
Transfer Speed	6Mbps, 12Mbps
Transfer I/F	Differential method, Pulse transfer resistance
Error Check	Format check, bit check, CRC-12 check
No. of Stations	63 (max.), 1008 I/O points

2.2.2 Flex Network I/O Unit Input/Output

■ 16 Point Input Sink/Source type (FN-X16TS11, FN-X16TS41)

Rated Input Voltage	DC24V	
Max. Input Voltage	DC28.8V	
No. of Input Points	16 points (sink/source type - dual use)	
Input Type	Type 1 ^{*1}	
Input ON Voltage	DC15V or higher	
Input OFF Voltage	DC5V or less	
Input Impedance	4.1kΩ	
Input Delay	OFF-ON	1.5ms or less
	ON-OFF	1.5ms or less
No. of Exclusive Use Nodes	1	

*1 Digital input is for detecting signals from mechanical switching devices such as relay contacts, push buttons, switches, etc.

Input Operating Range

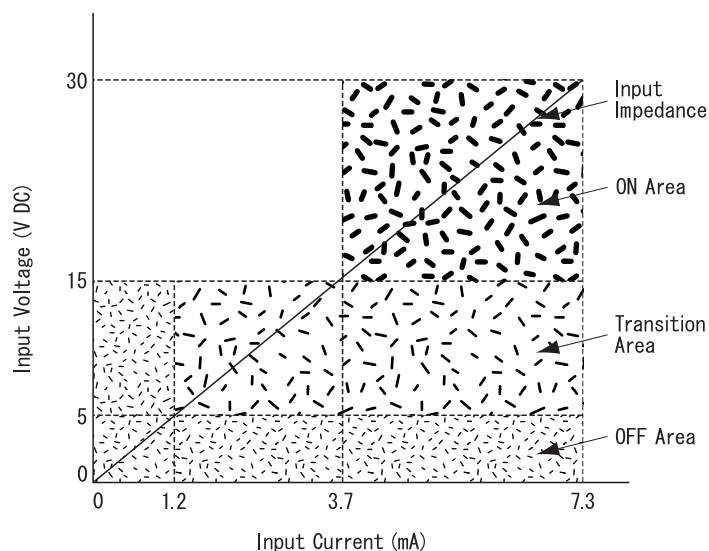

Rated Input Voltage 24VDC (sink/source input type)

■ **8 Point Input Sink-Source /8 Point Transistor Output Source Type (FN-XY08TS11, FN-XY08TS41)**

INPUT	Rated Input Voltage		DC24V
	Max. Input Voltage		DC28.8V
	No. of Input Points		8 points (sink/source type - dual use)
	Input Type		Type 1 ^{*1}
	Input ON Voltage		DC15V or higher
	Input OFF Voltage		DC5V or less
	Input Impedance		4.1kΩ
	Input Delay		OFF-ON
ON-OFF			1.5ms or less
OUTPUT	Rated Output Voltage		DC24V
	Rated Output Voltage Range		DC20.4V to DC28.8V
	No. of Output Points		8 points (Open drain sink output)
	Output Current		0.2A or less
	Short Circuit Protection		None
	Voltage Drop (ON Voltage)		DC1.5V or less
	Clamp Voltage		DC39V +/-1V
	Current Leakage		0.1mA or less
	Output Delay Time		OFF-ON
ON-OFF			1ms or less
No. of Exclusive Use Nodes			1

*1 Digital input is for detecting signals from mechanical switching devices such as relay contacts, push buttons, switches, etc.

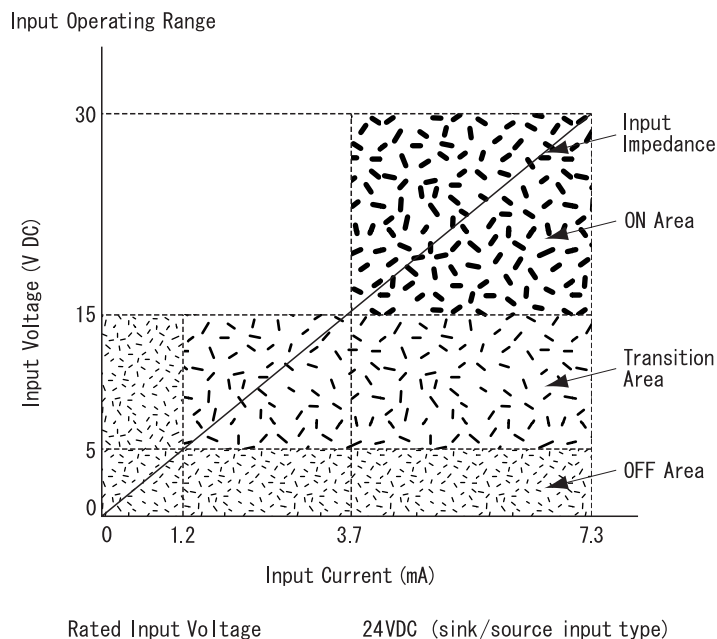

■ **8 Point Relay Output/1 Common (FN-Y08RL11, FN-Y08RL41)**

Rated Output Voltage (from V+ to V-)		DC24V
Rated Output Voltage Range (from V+ to V-)		DC20.4V to DC28.8V
Power Consumption		1.2W or less (when all outputs are ON /DC24V)
No. of Output Points		8 points/1 common
Maximum Load Voltage		1.0A/1 point (8 points/1 common - Max. common current 4.0A)
Contact Rating		AC240V, 1A (resistance load, induced load) DC24V, 1A (resistance load, induced load)
Output Delay Time	OFF- ON	10ms or less
	ON- OFF	5ms or less
Max. Open/Close Load		1mA/DC5V
Initial Shorting Resistance		50mΩ or less
Electrical Life		100,000 operations or more
Mechanical Life		20 million operations or more
No. of Exclusive Use Nodes		1

■ **16 Point Output Sink Type (FN-Y16SK41)**

Rated Output Voltage (from V+ to V-)		DC24V
Rated Output Voltage Range (from V+ to V-)		DC20.4V to DC28.8V
No. of Output Points		16 points
Output Current		0.2A/point (16 points/1 common, max. common current 2.0A)
Short Circuit Protection		None
Voltage Drop (ON Voltage)		DC1.5V or less
Clamp Voltage		DC39V +/-1V
Current Leakage		0.1mA
Output Delay Time	OFF- ON	1ms or less
	ON- OFF	1ms or less
No. of Exclusive Use Nodes		1

■ **16 Point Output Source Type (FN-Y16SC41)**

Rated Output Voltage (from V+ to V-)		DC24V
Rated Output Voltage Range (from V+ to V-)		DC20.4V to DC28.8V
No. of Output Points		16 points
Output Current		0.2A/point (16 points/common, max. common current 2.0A)
Short Circuit Protection		None
Voltage Drop (ON Voltage)		DC1.5V or less
Clamp Voltage		DC39V +/-1V
Current Leakage		0.1mA
Output Delay Time	OFF-ON	1ms or less
	ON-OFF	1ms or less
No. of Exclusive Use Nodes		1

■ **32 Point Input Source/Sink Type (FN-X32TS41)**

Rated Input Voltage		DC24V
Max. Input Voltage		DC28.8V
No. of Input Points		32 points (sink/source type - dual use)
Input Type		Type 1 ^{*1}
Input ON Voltage		DC15V or higher
Input OFF Voltage		DC5V or less
Input Impedance		4.2kΩ
Input Delay	OFF-ON	1.5ms or less
	ON-OFF	1.5ms or less
No. of Exclusive Use Nodes		2

*1 Digital input is for detecting signals from mechanical switching devices such as relay contacts, push buttons, switches, etc.

Input Operating Range

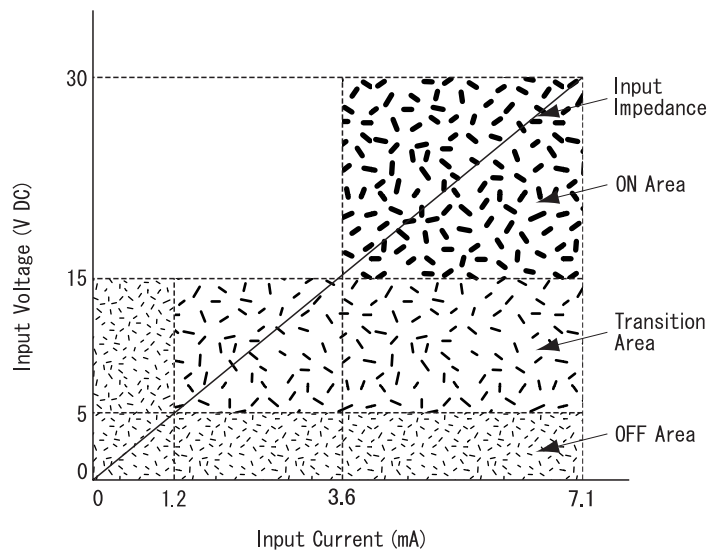

Rated Input Voltage

24VDC (sink/source input type)

■ **16 Point Input Sink-Source/16 Point Transistor Output Sink Type (FN-XY16SK41)**

INPUT	Rated Input Voltage		DC24V
	Max. Input Voltage		DC28.8V
	No. of Input Points		16 points (sink/source type-dual use)
	Input Type		Type 1 ^{*1}
	Input ON Voltage		DC15V or higher
	Input OFF Voltage		DC5V or less
	Input Impedance		4.2kΩ
	Input Delay Time	OFF-ON	1.5ms or less
ON-OFF		1.5ms or less	
OUTPUT	Rated Output Voltage		DC24V
	Rated Output Voltage Range		DC20.4V to DC28.8V
	No. of Output Points		16 points (sink type)
	Output Current		0.2A/1 point (16 points/1 common, max. common current: 1.6A)
	Output Protection		None
	Built-in Fuse		3.5A, DC125V built-in Chip Fuse (cannot be replaced)
	Voltage Drop (ON Voltage)		DC1.5V or less
	Clamp Voltage		DC39V +/-1V
	Current Leakage		0.1mA or less
	Output Delay Time	OFF-ON	1ms or less
ON-OFF		1ms or less	
No. of Exclusive Use Nodes		1	

**1 Digital input is for detecting signals from mechanical switching devices such as relay contacts, push buttons, switches, etc.*

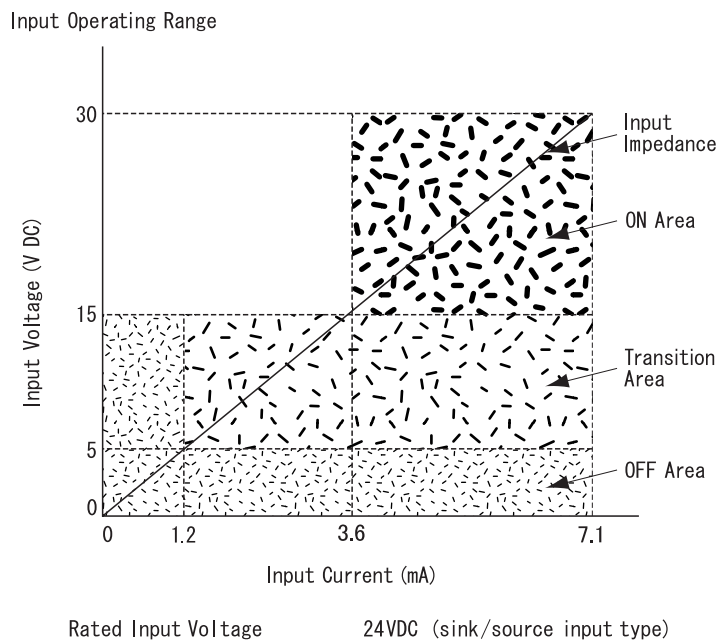

■ **16 Point Input Sink-Source/16 Point Transistor Output Source Type (FN-XY16SC41)**

INPUT	Rated Input Voltage		DC24V
	Max. Input Voltage		DC28.8V
	No. of Input Points		16 points (sink/source type-dual use)
	Input Type		Type 1 ^{*1}
	Input ON Voltage		DC15V or higher
	Input OFF Voltage		DC5V or less
	Input Impedance		4.2kΩ
	Input Delay Time		OFF-ON
ON-OFF			1.5ms or less
OUTPUT	Rated Output Voltage		DC24V
	Rated Output Voltage Range		DC20.4V to DC28.8V
	No. of Output Points		16 points (source type)
	Output Current		0.2A/1 point (16 points/1 common, max. common current: 1.6A)
	Output Protection		None
	Built-in Fuse		3.5A, DC125V built-in Chip Fuse (cannot be replaced)
	Voltage Drop (ON Voltage)		DC1.5V or less
	Clamp Voltage		DC39V +/-1V
	Current Leakage		0.1mA or less
	Output Delay Time		OFF-ON
ON-OFF			1ms or less
No. of Exclusive Use Nodes		1	

*1 Digital input is for detecting signals from mechanical switching devices such as relay contacts, push buttons, switches, etc.

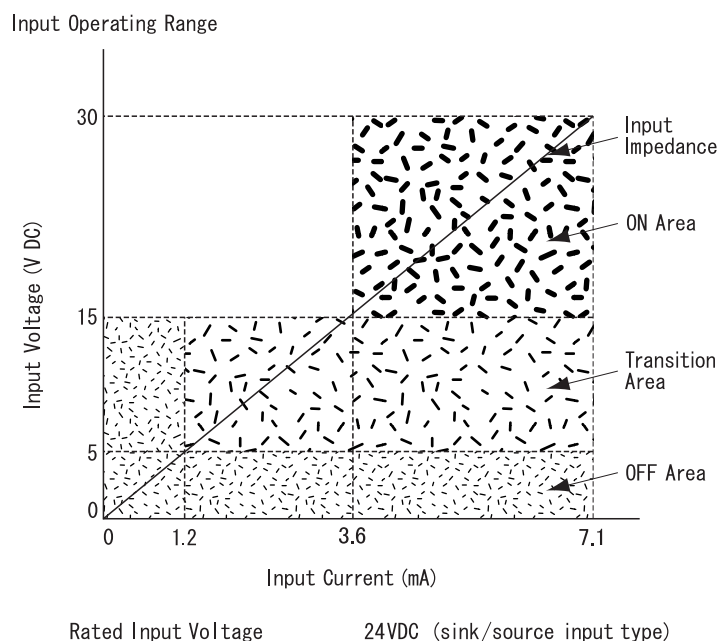

2.3 Input/Output Circuit Drawings



This section explains the Flex Network I/O unit circuit connection drawings.

Note: If the I/O unit's power and output lines, and the sensor power lines seem to be receiving excessive levels of field noise, be sure to separate the power and signal lines.

■ 16 Point Input Sink/Source Type (FN-X16TS11, FN-X16TS41)

This drawing shows the connection between the input section and the sink output type.

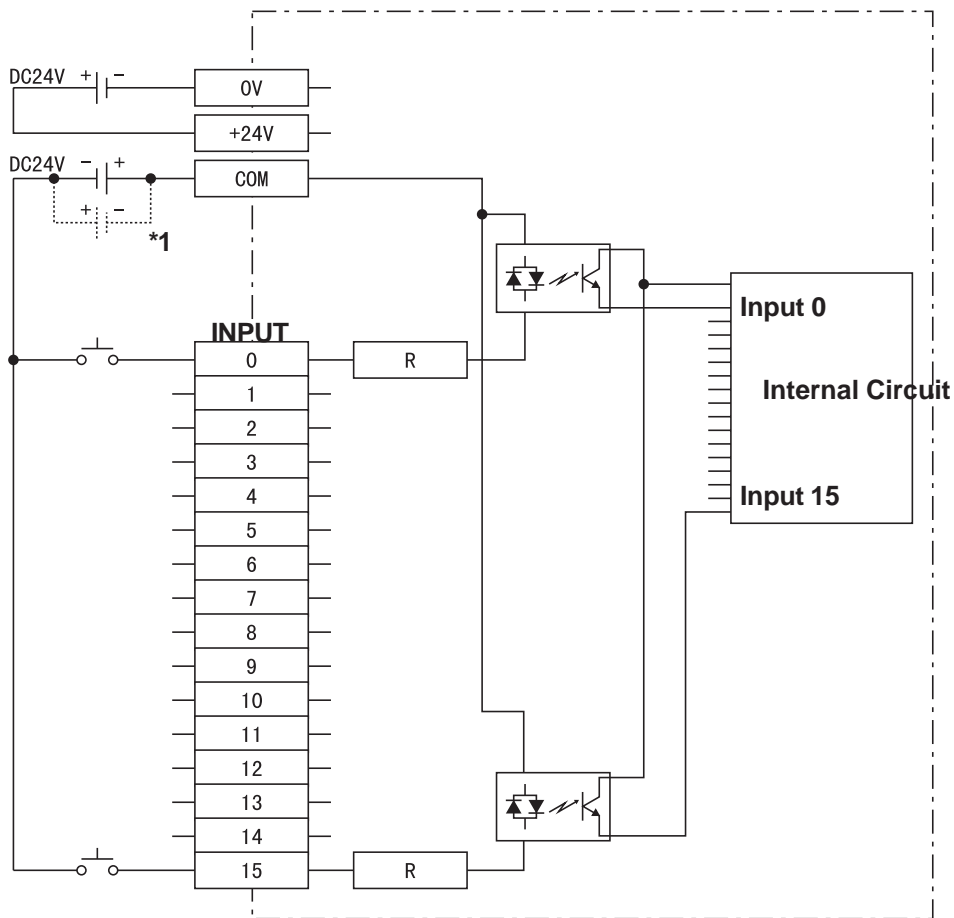

*1 Dotted line shows the source output connection.

■ **8 Point Input Sink-Source/8 Point Transistor Output Sink Type (FN-XY08TS11, FX-XY08TS41)**

This drawing shows the connection between the input section and the sink output type.

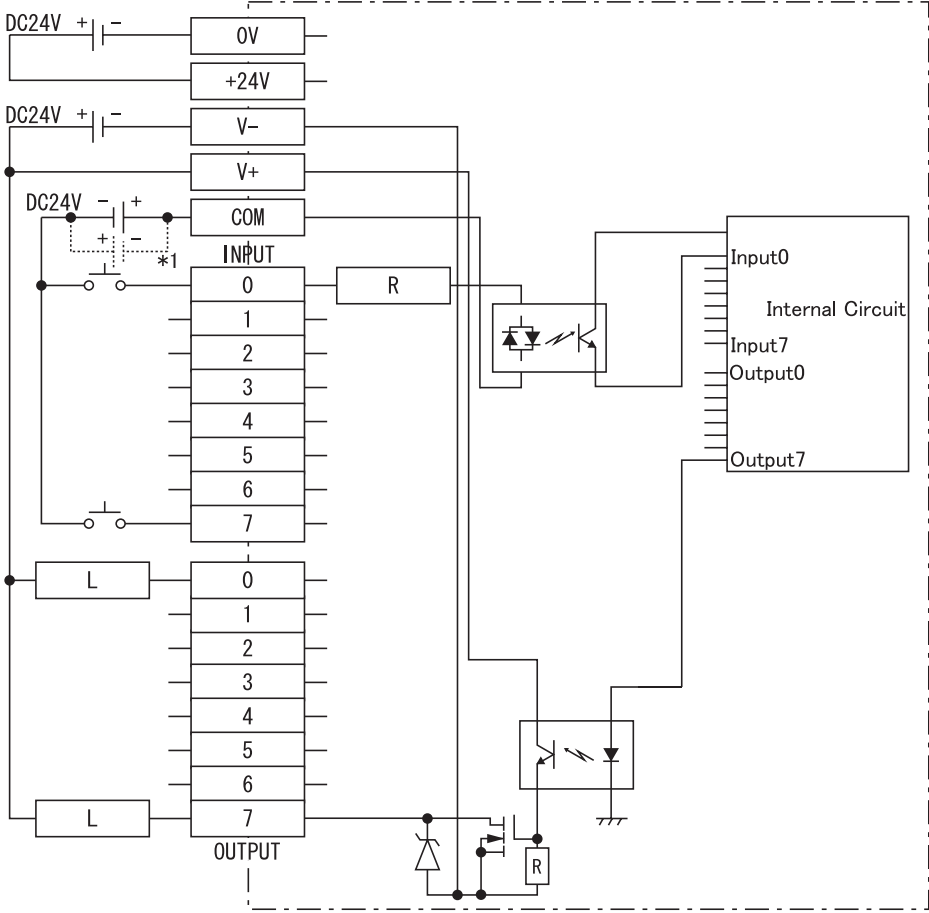

*1 Dotted line shows the source output connection.

■ **8 Point Relay Output/1 Point Common
(FN-Y08RL11, FN-Y08RL41)**

The relay specifications can change the COM power supply.

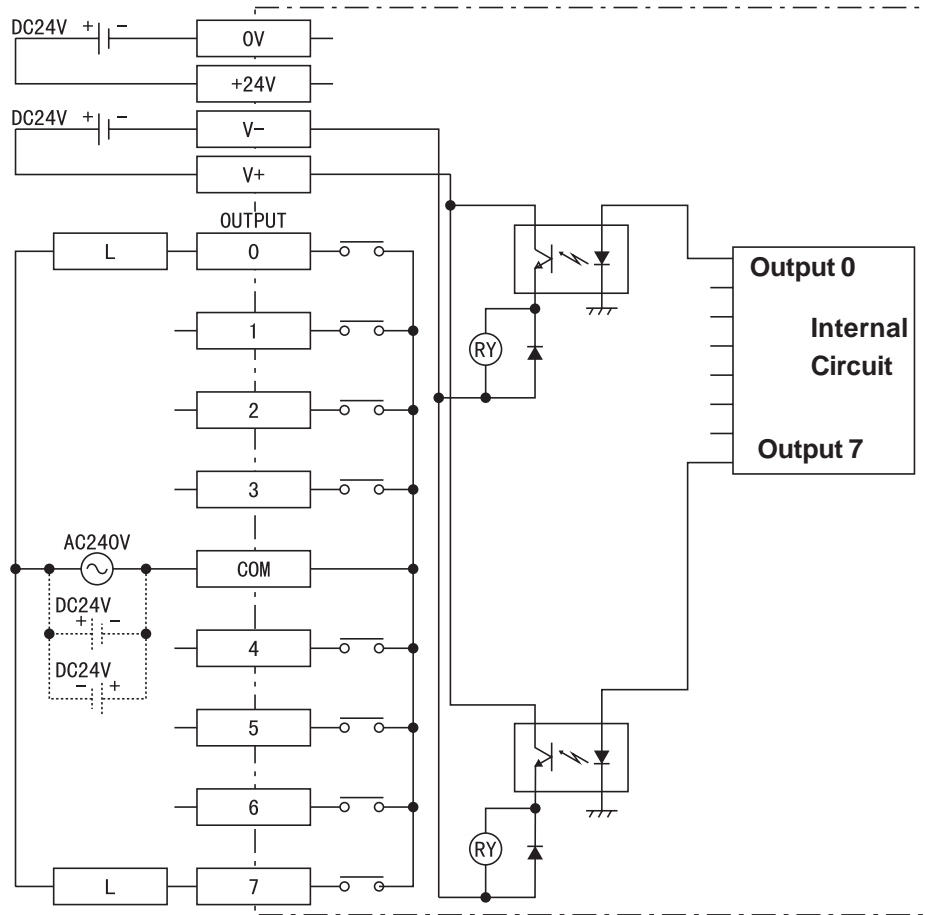

■ 16 Point Output Sink Type (FN-Y16SK41)

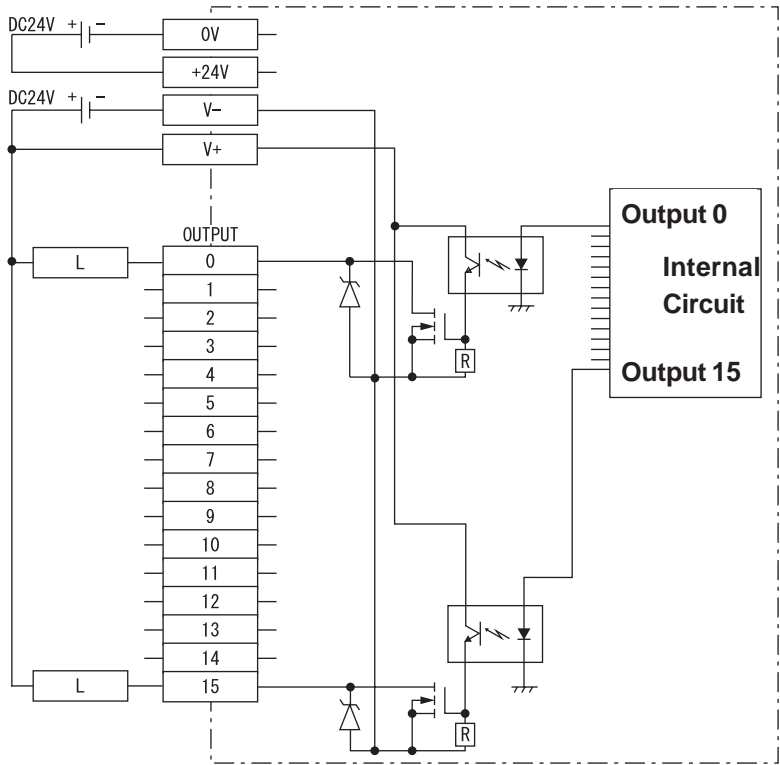

■ 16 Point Output Source Type (FN-Y16SC41)

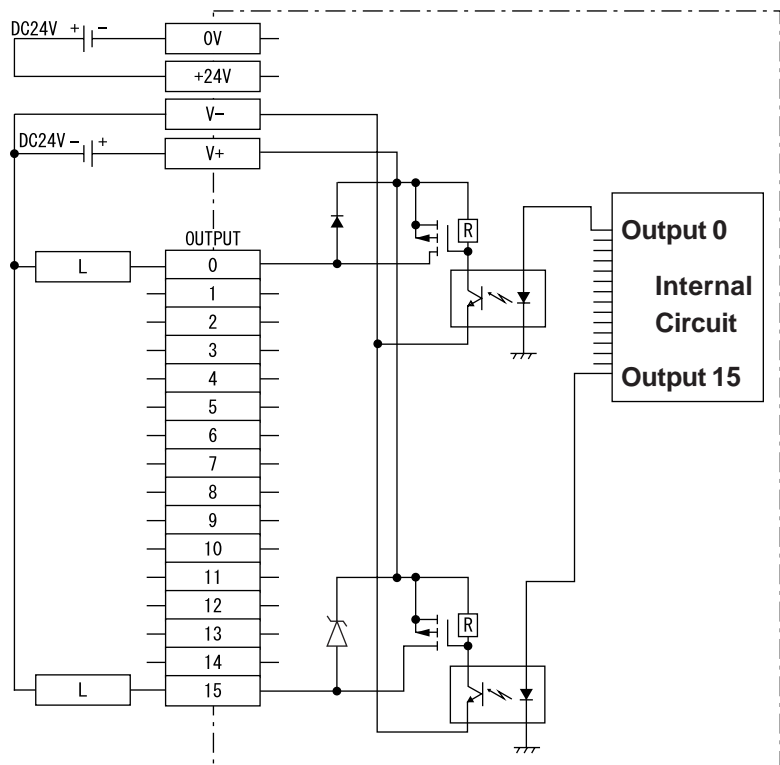

■ 32 Point Input Sink/Source Type (FN-X32TS41)

This drawing shows the connection between the input section and the sink output type.

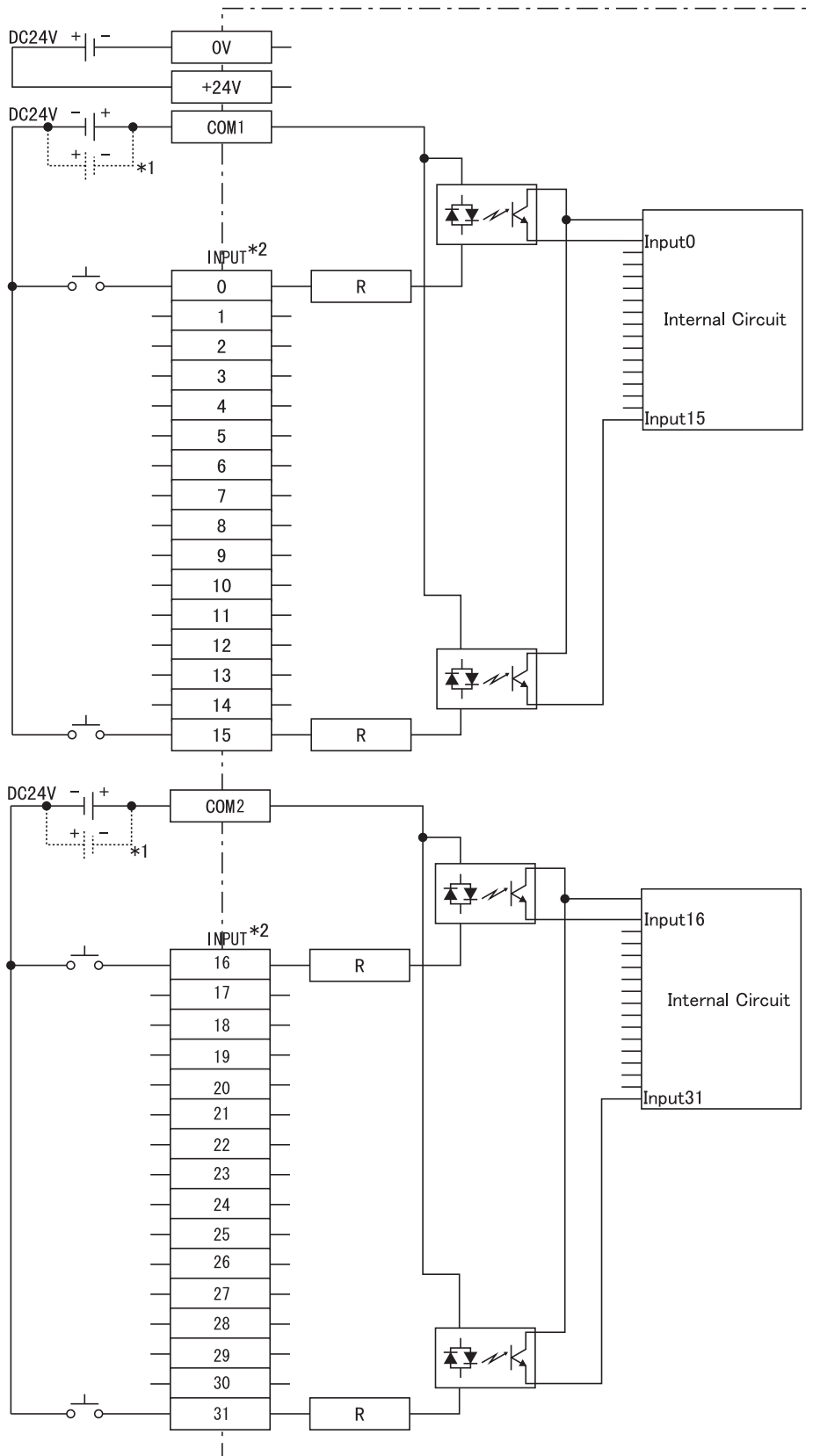

*1 Dotted line shows the source output connection.

*2 When IN0 to IN15 are used, use COM1.

When IN16 to IN31 are used, use COM2 as the input common.

■ **16 Point Input Sink-Source/16 Point Transistor Output Sink Type (FN-XY16SK41)**

This drawing shows the connection between the input section and the sink output type.

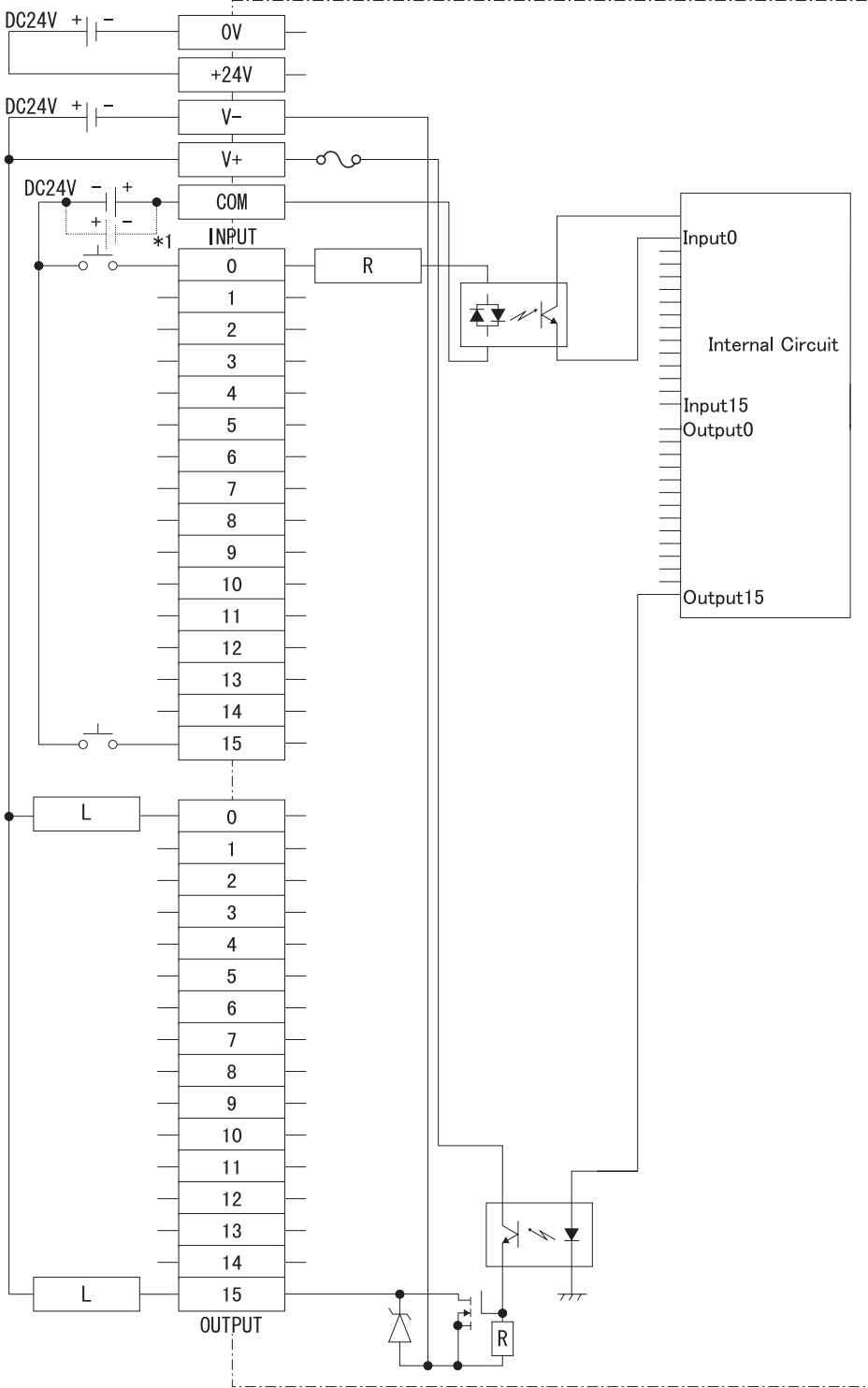

*1 Dotted line shows the source output connection.

■ **16 Point Input Sink-Source/16 Point Transistor Output Source Type (FN-XY16SC41)**

This drawing shows the connection between the input section and the source output type.

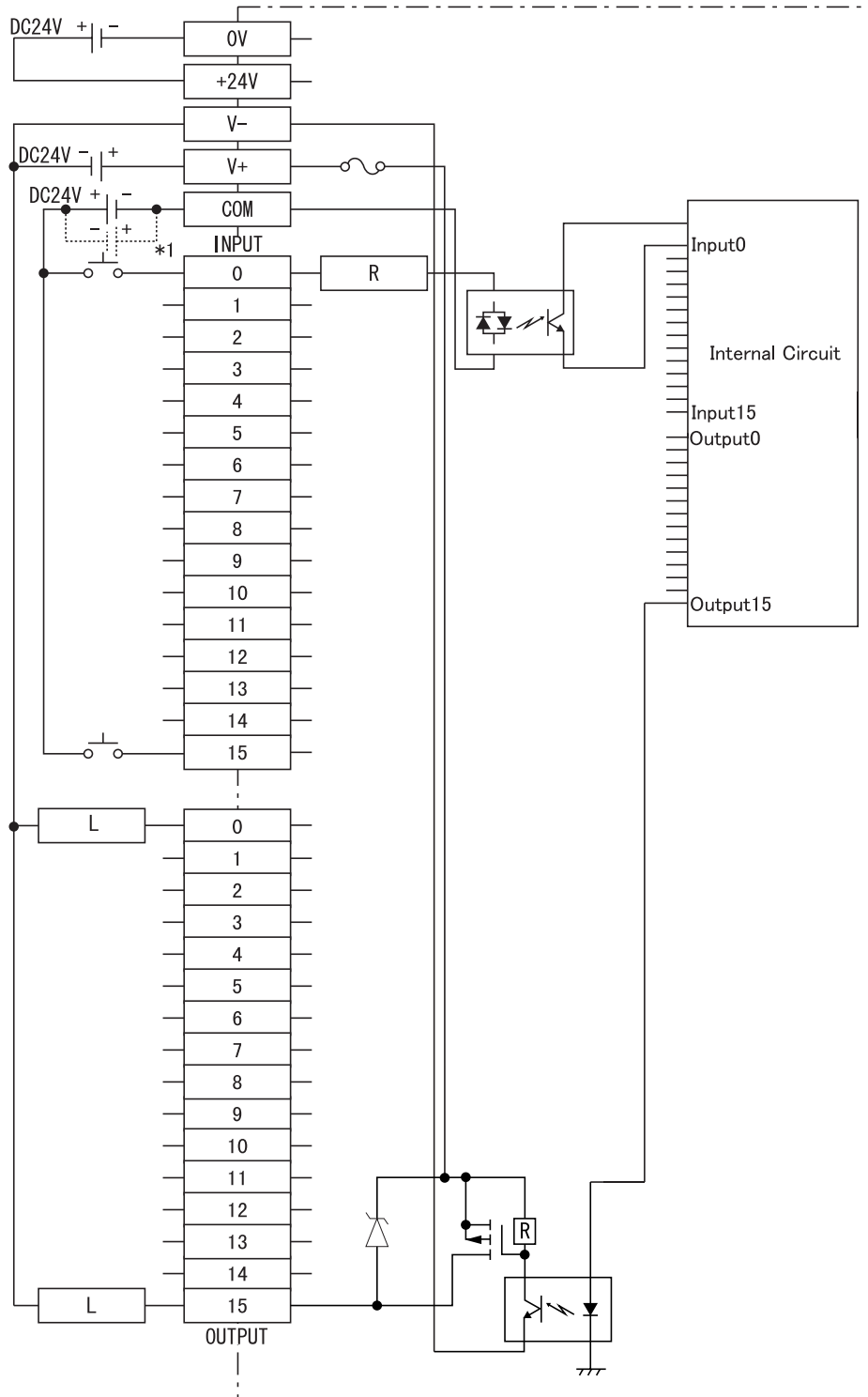

*1 Dotted line shows the sink output connection.

2.4 Part Names and Features

The Flex Network I/F Unit (GLC100-FN11/GLC100-FN41) is compatible with all GLC100 Series and GLC300 Series units. It is not required for GLC2000 Series/LogiTouch Series Units.

Reference *GLC2000 Series User Manual/LogiTouch Series User Manual*

2.4.1 Flex Network I/F Unit

A: GLC Connector

Connects to GLC Expansion Unit connector.

B: Flex Network I/F Unit Connector

Flex Network I/O unit connects here to provide Flex Network communication connector.

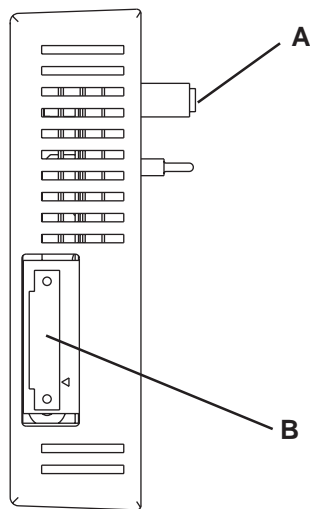

	Pin No.	Signal Name
	6	CH2 Shield Line (SLD)
	5	CH2 Data Transmit (TR-)
	4	CH2 Data Transmit (TR+)
	3	CH1 Shield Line (SLD)
	2	CH1 Data Transmit (TR-)
	1	CH1 Data Transmit (TR+)

C: Status LED

Indicates the status of the unit.

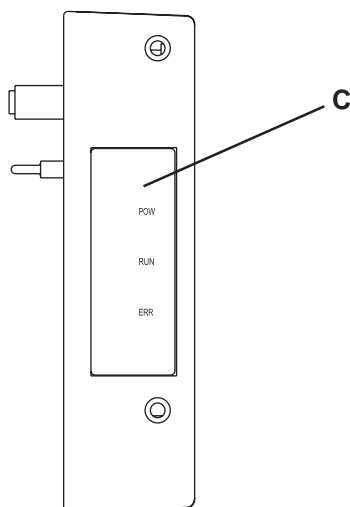

Status LED	Condition
POW (Green LED)	When power is supplied
RUN (Green LED)	Blinks when data transfer is enabled.
ERR (RED LED)	Blinks when the unit is malfunctioning.

2.4.2 Flex Network I/O Unit

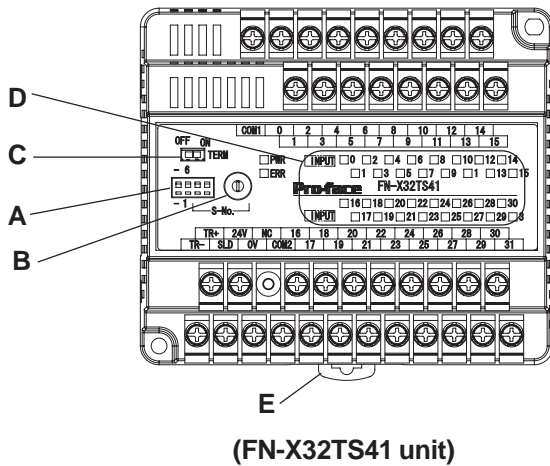
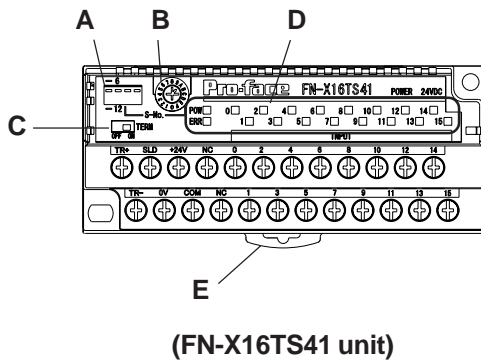

A: Dip Switches

Sets the output hold settings, transmission speed and station no. (upper 1st digit).

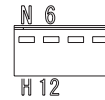

B: Rotary Switch

Uses the lower 1st digit to set the station no.



8/16 point

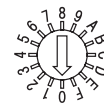

32 point

C: Terminator

Turns the termination resistance feature ON or OFF.



D: Status LED

Indicates the following conditions.

Status LED	Condition
PWR (Green LED)	When unit is first turned ON.
ERR (RED LED)	Lights when the unit is malfunctioning.
0 - 15 (ORANGE LED)	Lights when each I/O point turns ON.

E: DIN Rail Attachment Hook

Use to attach the I/O Unit to the DIN rail.

■ Output Hold Settings

The left-most dip switch is used to turn this setting ON/OFF. The factory setting is OFF (No Hold)

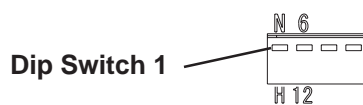

Output Hold OFF
↑
↓
Output Hold ON

◆ Output Hold ON (Hold)

When a communication error occurs, the unit will HOLD the output condition received in the previous communication cycle. When the next cycle is performed and the next command is successfully received, the output will then be changed.

◆ **Output Hold OFF (Non-Hold)**

When a communication error occurs, all outputs are reset to 0 (OFF). When normal communication is restored, the output is also restored.



- **When output hold is used, the output ON signal is held when an error occurs. As a result, be sure to structure your system so that a V+ terminal does not control an emergency safety circuit. This type of feature is usually referred to as a fail-safe system.**

▼ **Reference** 3.2.3 Connecting the I/O Cable (With 2 transistor units)

- **When the Logic Program changes from the RUN condition to either the OFFLINE mode or RESET, The GLC or the I/O signal will be performed as shown below, regardless of the Output Hold Setting. Be sure to consider this when changing to either the OFFLINE or RESET modes.**

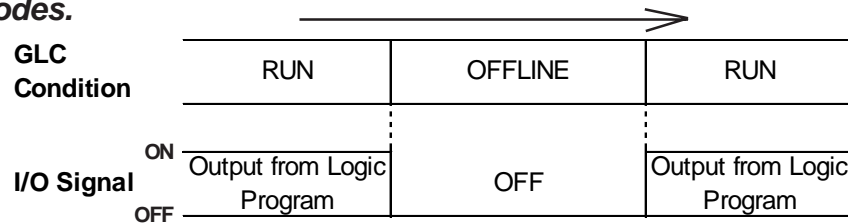

Please remember that the Reset mode's I/O signal OFF timing is not fixed.

■ **Communication Speed Settings**

The Dip Switch that is the second from the left controls the communication speed (6Mbps or 12Mbps). The factory setting is 6Mbps and is recommended.

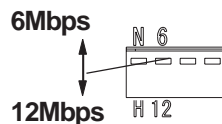

The Communication Speed setting status is read when the FN-HC unit is turned ON. To change this setting, turn the FN-HC unit OFF, change the setting and then turn the unit ON again.

■ **S-No. (Station Number) Setting**

Station numbers from 1 to 63 are set in hexadecimal (01h to 3Fh) The factory setting is 0.

The hex upper digit is controlled by the two dip switches on the right side, via ON/OFF settings.

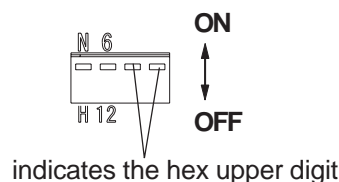

The arrow's tip indicates the position

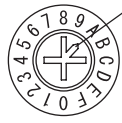

8/16 point

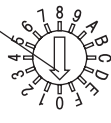

32 point

S-No. Setting Example

S-No.	Dip Switch		Rotary Switch
	the 2nd from the right	right side	
Base 10			
S-No. 1 (01h)	OFF (0)	OFF (0)	1
S-No. 16 (10h)	OFF (0)	ON (1)	0
S-No. 63 (3Fh)	ON (1)	ON (1)	F



The S-No. setting status is read when the FN-HC unit is turned ON. To change this setting, turn the FN-HC unit OFF, change the setting and then turn the unit ON again.

■ Termination Settings

This setting helps prevent reflections (echoes) from the terminating unit. (adjusts the termination impedance)

Be sure that each channel in your system's final unit has this termination setting set to ON.

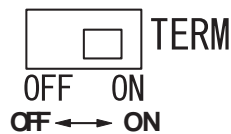

The Termination Resistance setting status is read when the FN-HC unit is turned ON. To change this setting, turn the FN-HC unit OFF, change the setting and then turn the unit ON again.

2.5 Dimensions

2.5.1 Flex Network I/F Unit

Units: mm [in.]

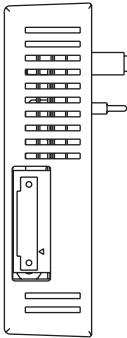
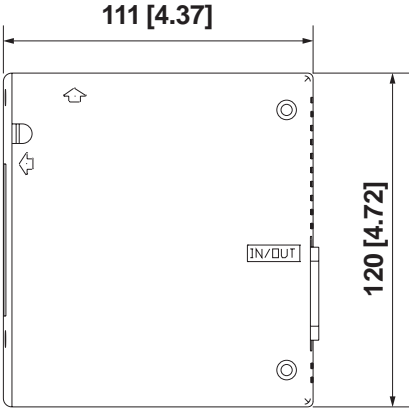
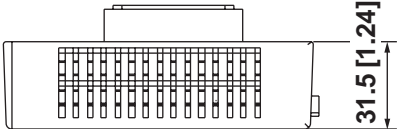

■ Flex Network I/F Unit when attached to a GLC 100

Units: mm [in.]

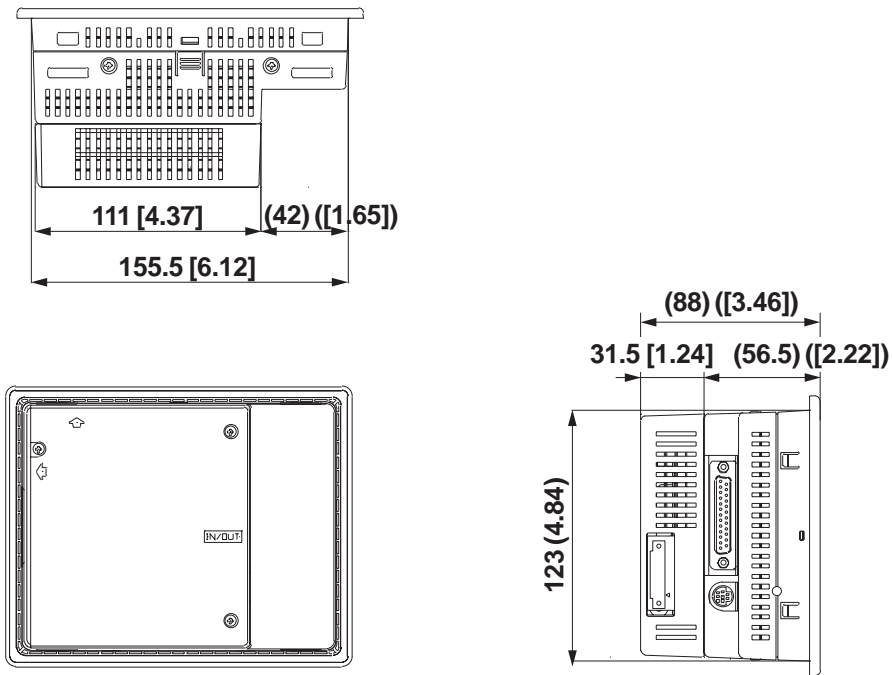

■ Flex Network I/F Unit when attached to a GLC 300

Units: mm [in.]



Note: When the Flex Network Unit is attached to a GLC 300 Series unit, the optional Bus Conversion Unit is required.

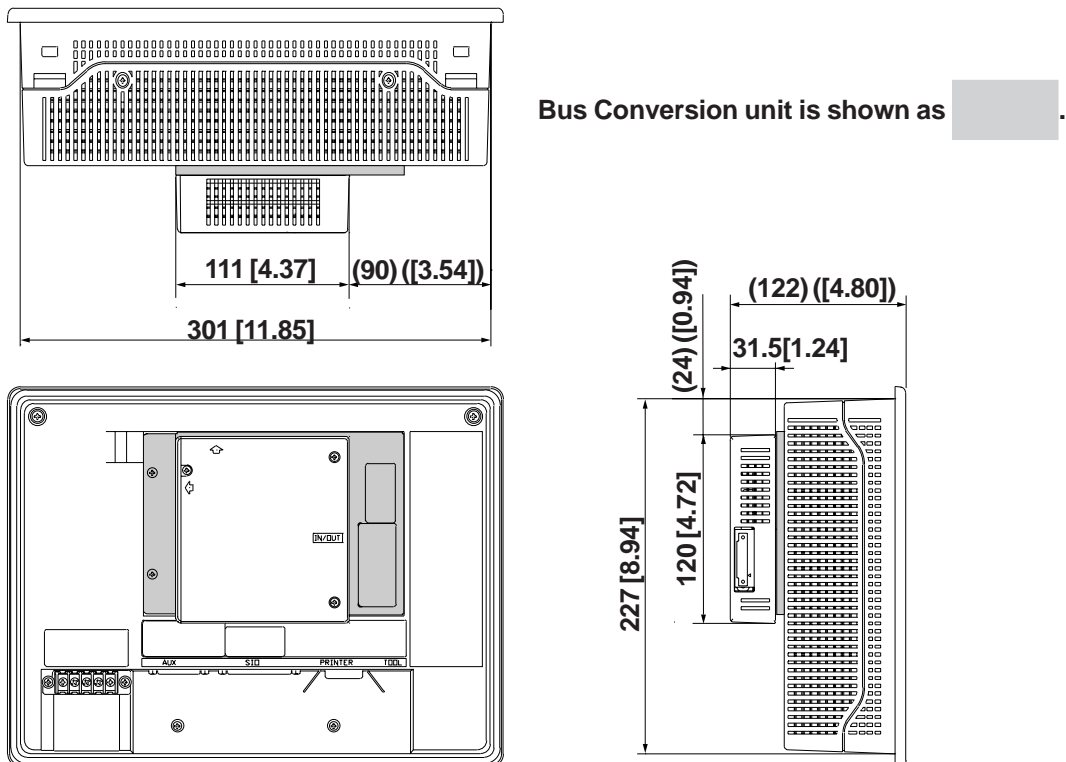

2.5.2 Flex Network I/O Unit

All I/O units share the same dimensions. Units shown here are 8/16 Point and 32 Point types.

■ 8/16 Point Unit

Units: mm [in.]

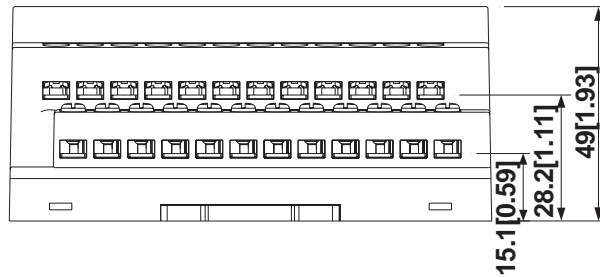
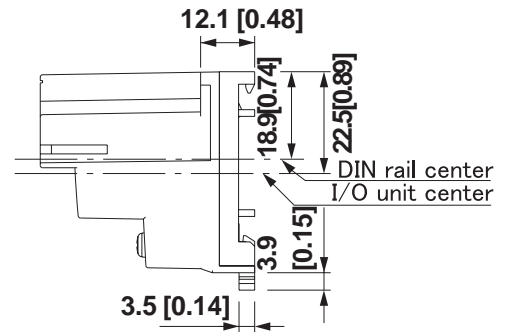
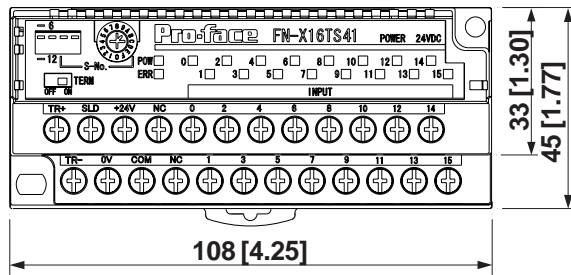

(FN-X16TS41 unit)

■ 32 Point Unit

◆ 32 Point Unit Only

Units: mm [in.]

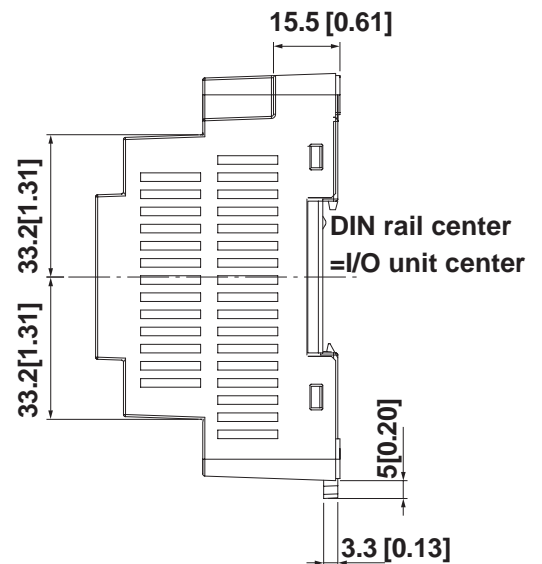
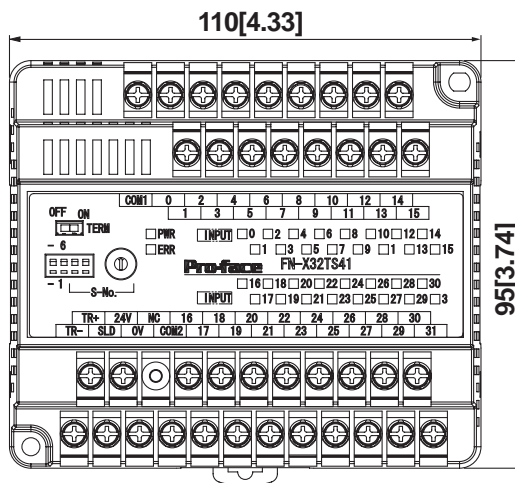

(FN-X32TS41 unit)

Chapter 2 - Specifications

◆ 32 Point unit when attached to a GLC2300 Series unit



Note:

The following diagrams show the I/O unit attached to a DIN rail (recommended length: 105mm), which is attached to the rear of the GLC. This type of installation is only for GLC 2300 Series units.

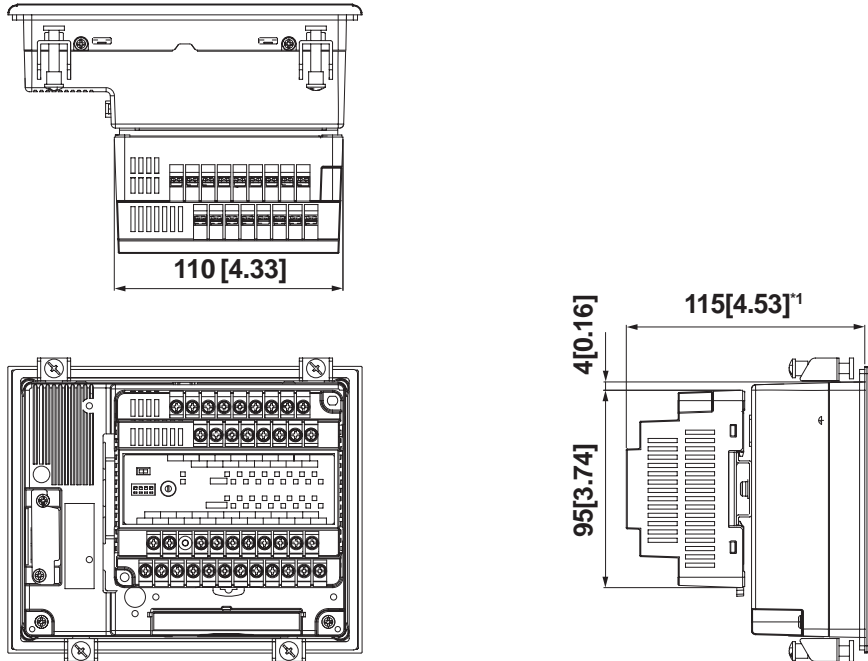

*1 This depth dimension (115mm) includes a DIN rail. (H35mm x D7mm)

Chapter

3 Installation and Wiring

1. Installation

2. Wiring

The Flex Network I/F Unit (GLC100-FN11/GLC100-FN41) is compatible with all GLC100 Series and GLC300 Series units. It is not required for GLC2000 Series/LogiTouch Series Units.

Reference *GLC2000 Series User Manual/LogiTouch Series User Manual*

3.1 Installation

WARNING

Prior to installing the Flex Network Unit:

Be sure that the main power supply is turned completely OFF before beginning to wire the unit.

3.1.1 Flex Network I/F Unit Installation



Note: Be sure to read the User Manual for you GLC unit prior to installing this expansion unit.

- 1) Be sure the GLC's main power supply is turned OFF.
- 2) Peel the GLC 100's rear face connector seal off to expose the connector.



Be sure the GLC unit's power cord terminals are attached to the GLC before installing the Flex Network I/F unit. This is because the power terminals cannot be connected after the Flex Network unit is attached.

Reference *GLC Unit User Manual*

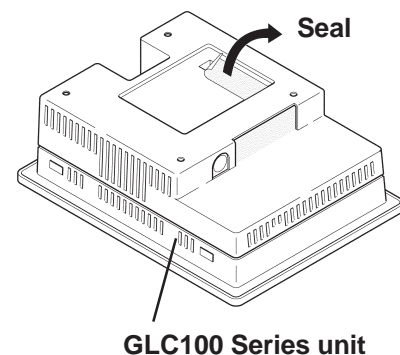

- 3) Attach the Flex Network unit and secure it in place with its three (3) attachment screws.



Note:

- The torque required for these screws on only 0.5 to 0.6n•m²
- When attaching this unit to the GLC-300, a Bus Conversion adapter (GLC300-BCB41) is required.

Reference For this unit's installation method, refer to its Installation Guide.

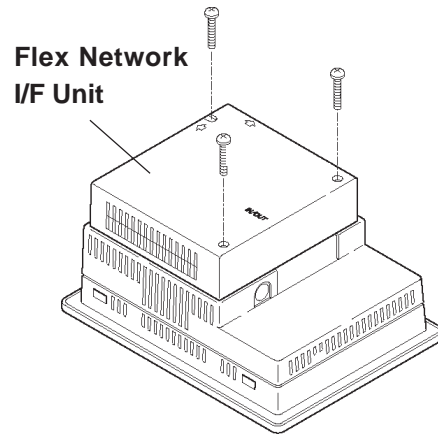

3.1.2 I/O Unit Installation/Removal

■ Attaching the Unit to a 35 mm DIN Rail

◆ Attachment

Place the unit's curved, top lip over the top of the DIN rail, and then tilt the unit down until the bottom face attachment clip clicks into place.

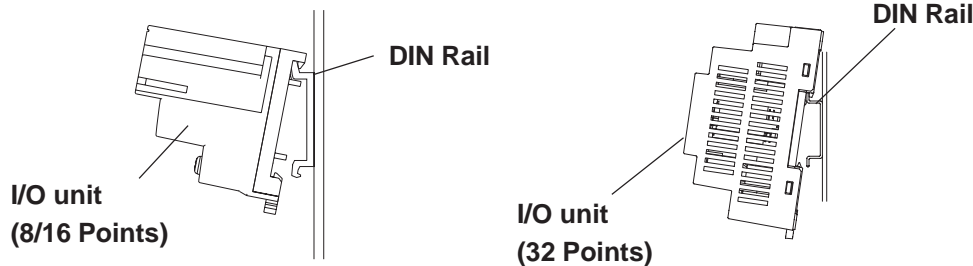

Important

- Be sure to confirm the unit's top and bottom faces before installing the unit.
- The unit's attachment clip can be set to remain open. When attaching the unit, be sure to close the attachment clip completely and confirm that the I/O unit is set securely on the DIN rail.

◆ Removal

Use a standard screwdriver to force the unit's attachment clip down until the bottom of the unit is freed from the rail. Next, tilt the unit up and remove.

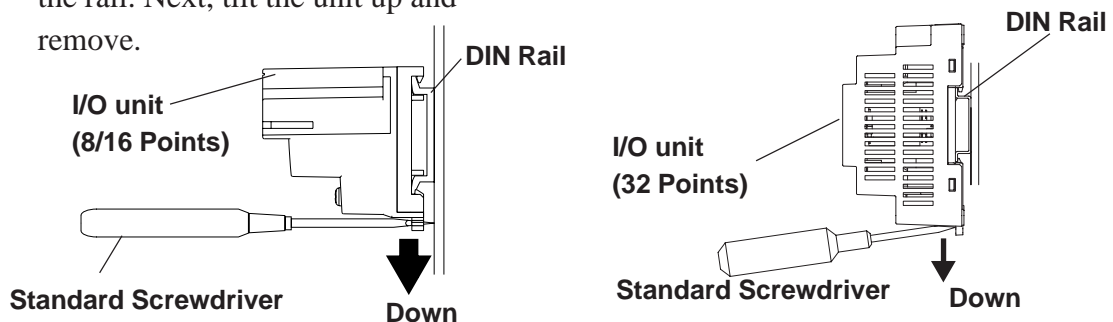

■ When Installing the Unit in a Panel

Drill installation holes in the panel according to the dimensions given below and use M4 screws to attach the unit. A torque of only 0.5 to 0.6N•m is sufficient.

Unit: mm [in.]

8/16 Point Unit

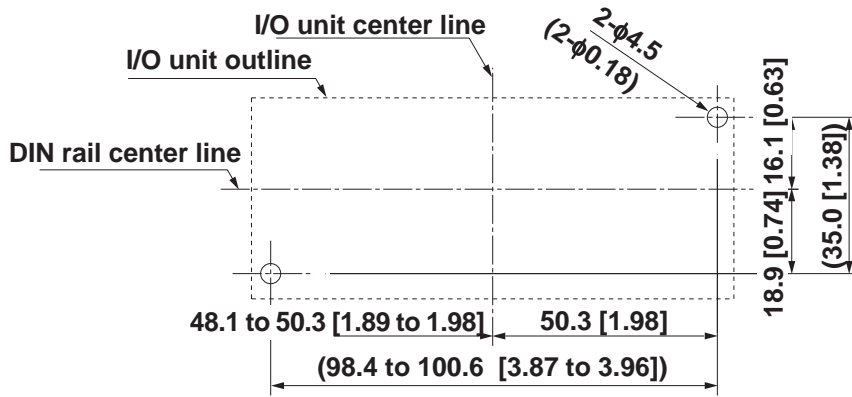

32 Point Unit

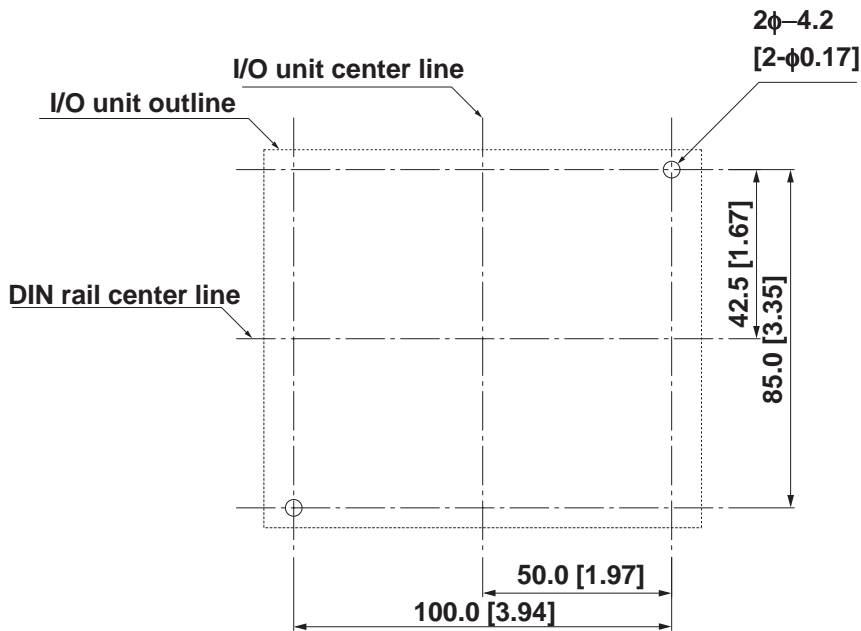

3.1.3 Attaching a 32-Point I/O Unit

This explanation attaches a 32-Point I/O Unit to a DIN rail, then to the rear of the GLC.



This installation method can only be used with a GLC2300 Series unit.

- 1) Attach the DIN rail (H35mm, recommended length: 105mm) to the rear of the GLC2300. Fasten the two (2) M4 screws as shown. (The length is less than 6mm.) The torque required for these screws is only 0.5 to 0.6 N•m².

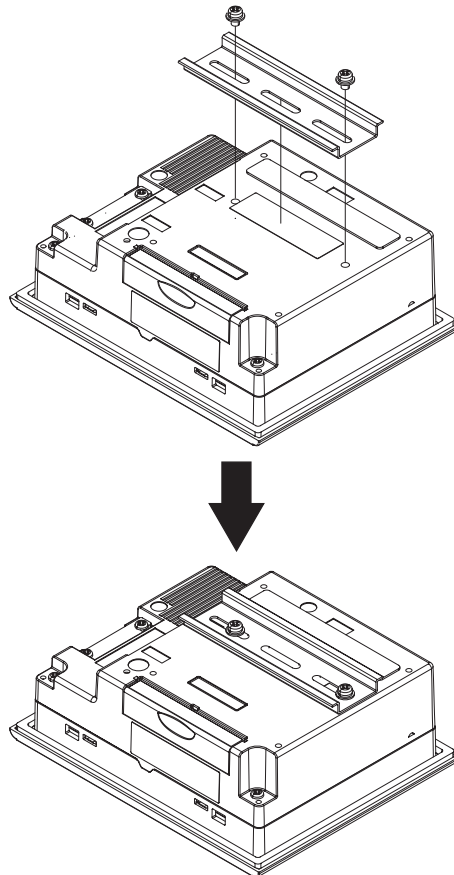

- 2) Attach the I/O Unit (32-Point unit) to the DIN rail.

Reference ▲ 3.1.2 I/O Unit Installation/Removal ■ Attaching the Unit to a 35mm DIN Rail

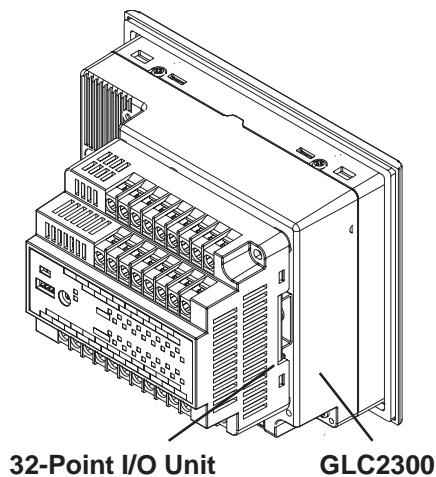

3.2 Wiring

WARNING

**Prior to wiring the Flex Network Unit:
Be sure that the main power supply is turned completely
OFF before beginning to wire the Unit.**

3.2.1 Connecting the Flex Network Data Transfer Cable

Use jumper wiring between the Flex Network I/F and I/O units, as well as between each distributed I/O unit (T-type connections are not possible)

We suggest the following cables for your Flex Network.

Retailer	Model No.	Length
Digital Electronics Corporation	FN-CABLE2010-31-MS	10m
	FN-CABLE2050-31-MS	50m
	FN-CABLE2200-31-MS	200m

■ Flex Network I/O Unit Wiring

The cable should be made as shown below:

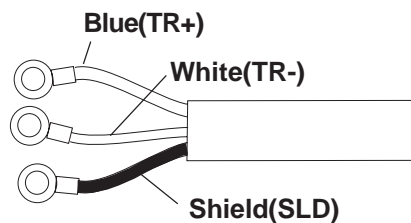

The shield line should either be taped or be covered with a plastic tube.

Use the following type of crimp terminals.

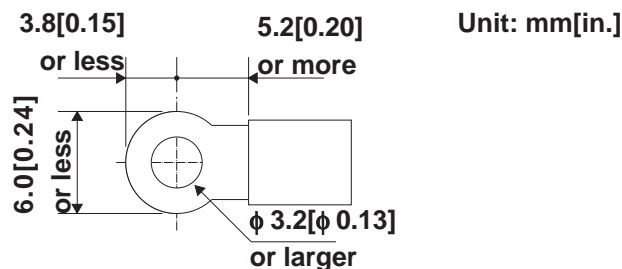

Crimp terminals should either be taped or be covered with a plastic tube.



- The required torque for securing ring terminals is 0.3 N•m²
- Up to 2 ring terminals can be attached to a single terminal screw.

Flex Network I/F Unit Wiring

Remove the wire's external covering and insert the wire center strand into the opening.

Unit: mm[in.]

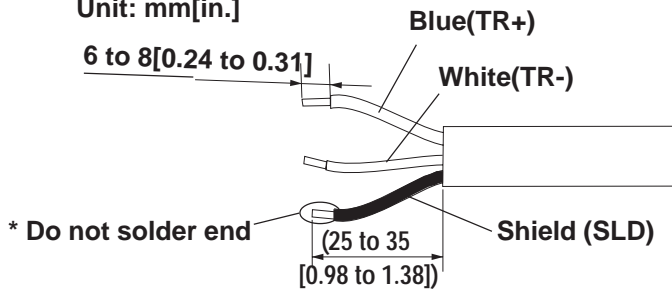

- Be sure to tape or put a plastic tube over the shield line.
- Do not solder the wire itself. This could lead to a bad or poor contact.

Connecting the Flex Network Cable to the Flex Network I/F Unit

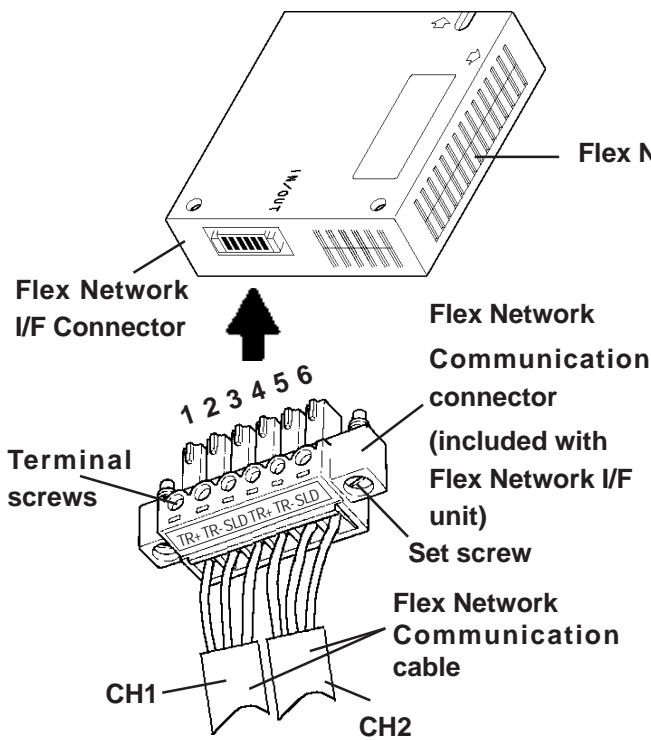

Pin No.	Insulation Color	Meaning
1	Blue	CH1 Comm. Data (TR+)
2	White	CH1Comm Data (TR-)
3	Shield	CH1 Shield (SLD)
4	Blue	CH2 Comm. Data (TR+)
5	White	CH2 Comm Data (TR-)
6	shield	CH2 Shield (SLD)

◆ Connecting the Flex Network Cable to a GLC2400/GLC2600 Series Unit

Screwlock Terminal Block

Pin No.	Signal	Meaning	
1	AUXCOM	External Reset Common	External Reset
2	AUXRESET	External Reset Input	
3	TR+	CH1 Communication Data	Flex Network Communication
4	TR -	CH1 Communication Data	
5	SLD	CH1 Cable/Shielded Line	
6	TR+	CH2 Communication Data	
7	TR -	CH2 Communication Data	
8	SLD	CH2 Cable/Shielded Line	
9	RESERVE	Reserve	-
10	SP OUT	Speaker Output	Sound Output
11	GND	Ground	
12	LINE OUT	Sound Output	

Reference For more information about the GLC2400/GLC2600 Series unit, see the "GLC2000 Series User Manual"

◆ Connecting the Flex Network Cable to a GLC2300/LogiTouch Series Unit

Screwlock Terminal Block

Pin No.	Signal	Meaning
1	TR+	CH1 Communication Data
2	TR -	CH1 Communication Data
3	SLD	CH1 Cable/Shielded Line
4	TR+	CH2 Communication Data
5	TR -	CH2 Communication Data
6	SLD	CH2 Cable/Shielded Line

Reference For more information about the GLC2300/LogiTouch Series unit, see each series unit's "User Manual"



- Use a small sized screwdriver to tighten the set screws.
- Use both attachment screws to attach the connector to the I/F unit. (recommended torque is 0.22 to 0.25N•m)
- If the central wire's end (individual) wires are not twisted correctly, the end wires may either short against each other, or against an electrode. When using pin terminals, the following maker is recommended.

Phoenix Connector: AI0.5-6WH AI0.3-6TQ

■ Flex Network System Wiring Layout

The following drawing shows the wiring layout used for wires from the Flex Network I/F connector.

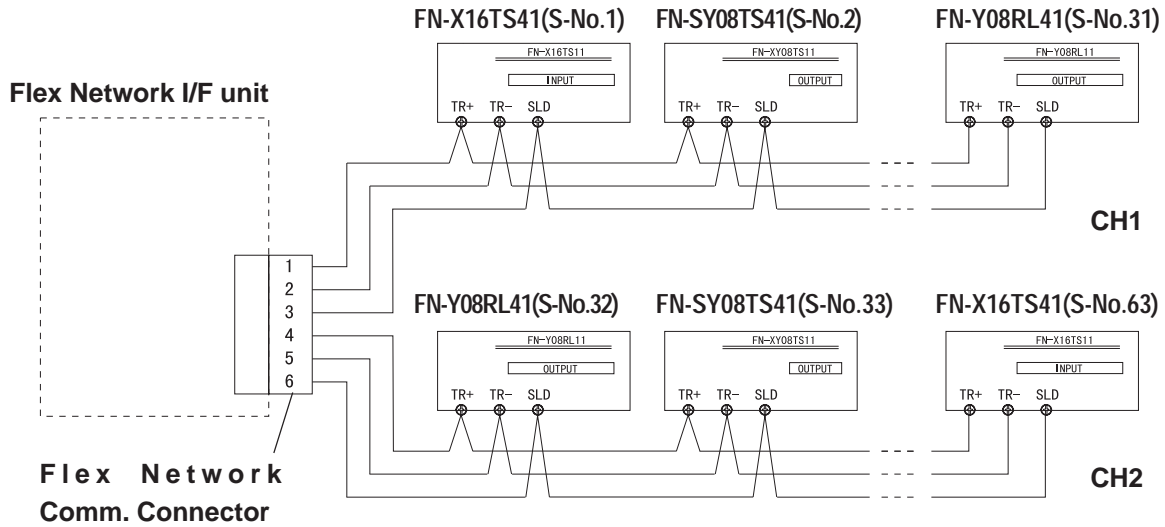

3.2.2 Connecting the Power Cord



WARNINGS

- Be sure that the main power supply is turned completely OFF before beginning to wire the unit's power cord.
- The I/O unit uses only DC24V power. Using either the incorrect voltage or AC power could result in damage to both the power supply and the unit.
- Since this unit has no OFF/ON switch, be sure to install a breaker type device to switch power ON or OFF.

- Wherever possible, use thick lines (max. 1.25mm²(0.05in²) and be sure to twist the wire ends to reduce noise.
- Use the same type of crimp terminals as used for the Flex Network Communication Cable.

3.2.3 Connecting the I/O Cable

- Be sure to use a cable that is 0.75 to 1.25mm²(0.03 to 0.05in²) thick.
- Use the same type of crimp terminals as used for the Flex Network Communication Cable.



- **Check that all I/O Unit terminal screws are securely tightened, even if they are not used.**
- **Do not allow the wire pieces to fall inside the unit.**

■ Input Wiring

When two (2) DC input units (FN-X16TS11/FN-X16TS41/FN-X32TS41) are used, with the same common line, use the following wiring setup.

For Sink Output type:

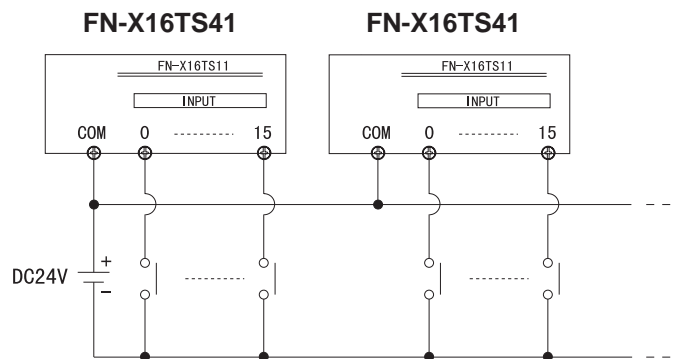

Note: When using a source output type, change the input circuit and the common (COM) lines.

■ Output Wiring

When using a Relay Output unit (FN-Y08RL11/FN-Y08RL41) together with noise generating magnetic devices or valves, attaching a diode for DC power, and a surge absorber for AC power is recommended

FN-Y08RL41

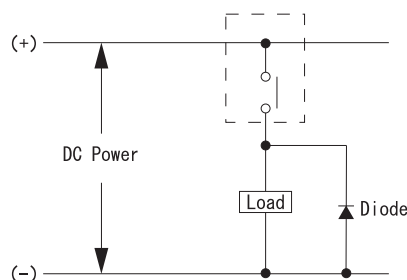

FN-Y08RL41

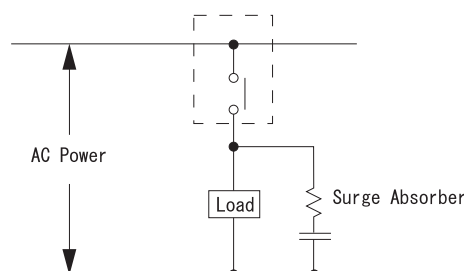

When using the Transistor output unit, (FN-XY08TS11/FN-XY08TS41/FN-Y16SC41/FN-Y16SK41/FN-XY16SK41/FN-XY16SC41), be sure to connect a Reverse Start Power Absorbing Diode to both ends of the load.

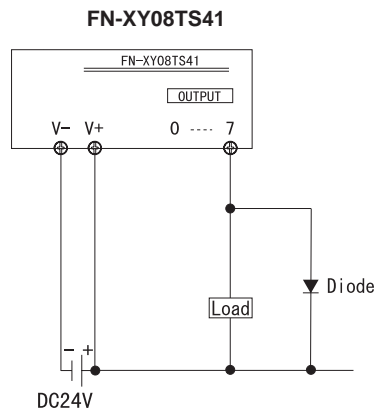

When using the Transistor output unit, (FN-XY08TS11/FN-XY08TS41/FN-Y16SC41/FN-Y16SK41/FN-XY16SK41/FN-XY16SC41), be sure to connect a Reverse Start Power Absorbing Diode to both ends of the load.

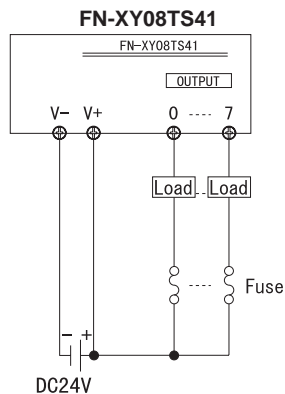

When attaching two (2) Transistor Output units (FN-XY08TS11/FN-XY08TS41/FN-Y16SC41/FN-Y16SK41/FN-XY16SK41/FN-XY16SC41) with the same Common line, be sure to use the wiring shown below.

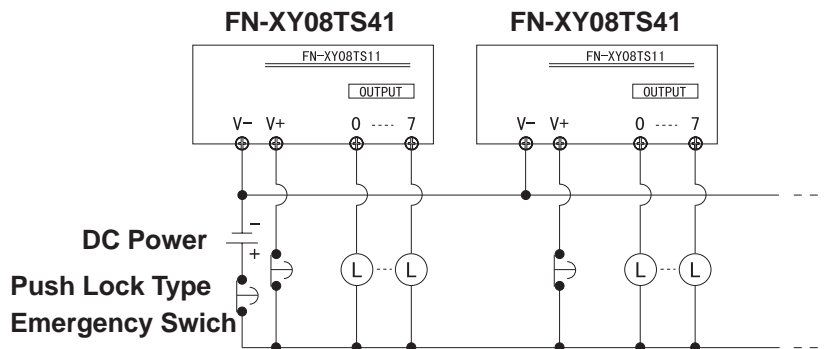

Do not use software to modify the Emergency Stop circuit. Instead, create a hardware circuit like the "Failsafe" circuit shown above.

3.2.4 General Cautions

Separating all communication lines from power lines by placing them in a separate duct will help to prevent problems from noise and interference.

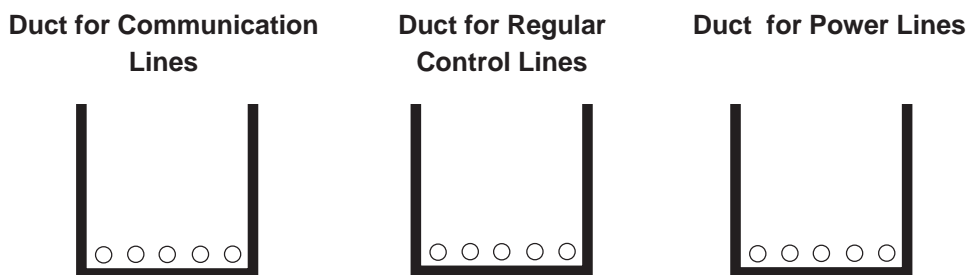

If the wires must be placed in the same duct, separate them via an earthed/grounded divider.

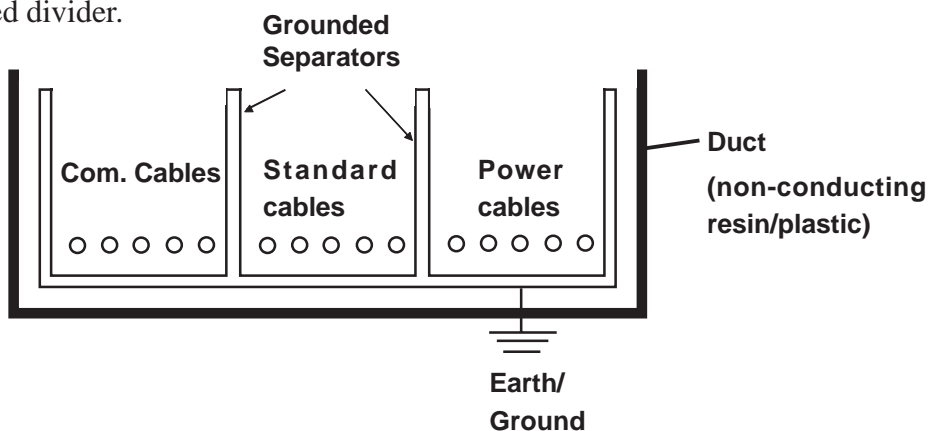

Note:

When you are unable to separate the cables as shown above, be sure to use shielded cable and create a ground from the shield line.



Important

- **Use noise-reducing external wiring methods to increase overall system reliability.**
- **To prevent power surges or noise interference, use ducts to separate all DC I/O or current circuit wires from communication cables.**
- **To prevent malfunctions due to noise, communication cables must be wired separately from high-frequency lines and power lines such as high-voltage lines, high-current lines, and inverters.**

Use the following wiring type and size guidelines when creating external wiring terminals.

Connection Type	Wiring Sizes (mm ²)	
	Smallest	Largest
Digital Input	0.5(AWG20)	1.25(AWG18)
Digital Output	0.5(AWG20)	1.25(AWG18)
Data Transfer (Use separate designated type)	—	—
Power	1.25(AWG18)	1.25(AWG18)
GND	1.25(AWG18)	1.25(AWG18)

Approved wire: UL1015 or UL1007 (except for the data transfer cable).

Memo

4 Problems and Solutions

4.1 Problem Solving

This section describes the Flex Network system's errors and their countermeasures.

4.1.1 Prior to Troubleshooting

Prior to locating a unit problem's cause via this chapter's section **4.1.3 Troubleshooting**, be sure to identify the the problem type and other basic items.

To help you with this, the Flex Network errors are classified into the following three types:

(1) Logic Program Error

- The logic program does not run (GLC status LED: Green is not lit).

(2) Flex Network I/F Unit Error

- Communication cannot be performed with any Flex Network I/O units.

(3) Flex Network I/O Unit Error

- Signal input or output cannot be performed for an I/O unit's points (all or some).

■ Check Items

After finishing your preliminary check, be sure to also check the following items before starting troubleshooting to locate the cause(s) of the problem.

- Is the correct power voltage being supplied to the GLC, I/F, and I/O units?
- Is the power supplied to the GLC and I/O unit(s) within the allowable voltage range?
- Are all connected cable wiring and connections (communication cable, I/O cable) secure and correct?
- Is any I/O unit terminals loose or disconnected?
- Are all I/O unit switches (rotary switch, dip switch, terminal switch) set correctly?
- Is the designated communication cable being used?

4.1.2 Error Code Display

The #IOStatus values, which are the GLC system variables, indicate the I/O driver error codes. By displaying an error code on the GLC screen, troubleshooting can be performed quickly.

The following is an example of an error code display application.

■ Application Example

- (1) Create the I/O system diagnosis button.
- (2) Create a ladder logic program so that, when the [System Diagnosis] button is pressed, the system status will be displayed as an error code.

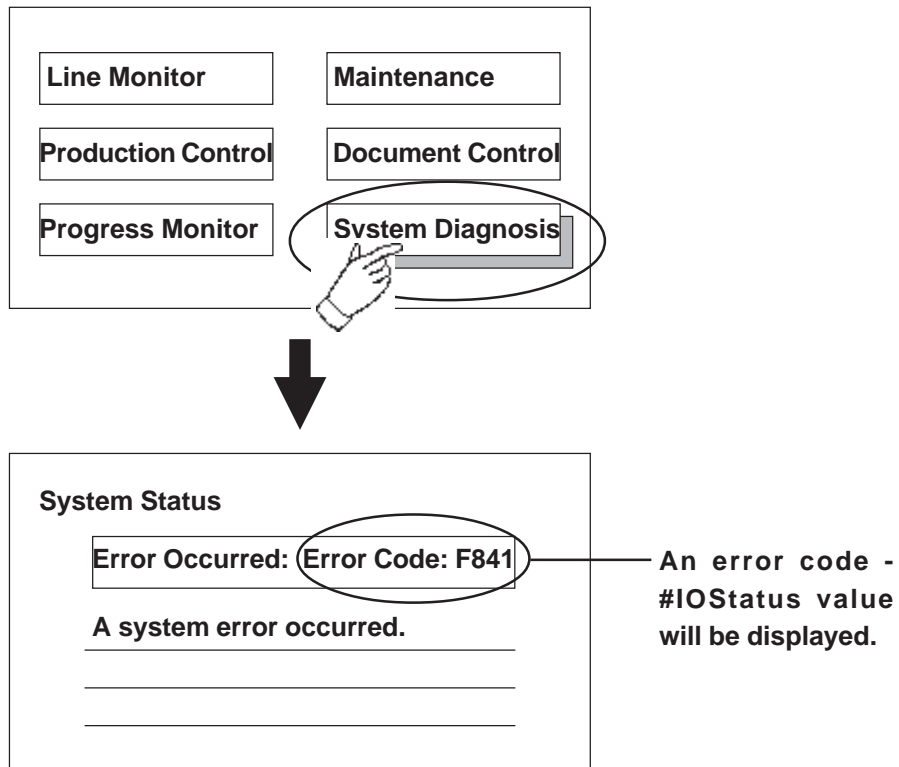

4.1.3 Troubleshooting

Use the following flowchart to locate the problem cause(s) and take appropriate countermeasure(s).

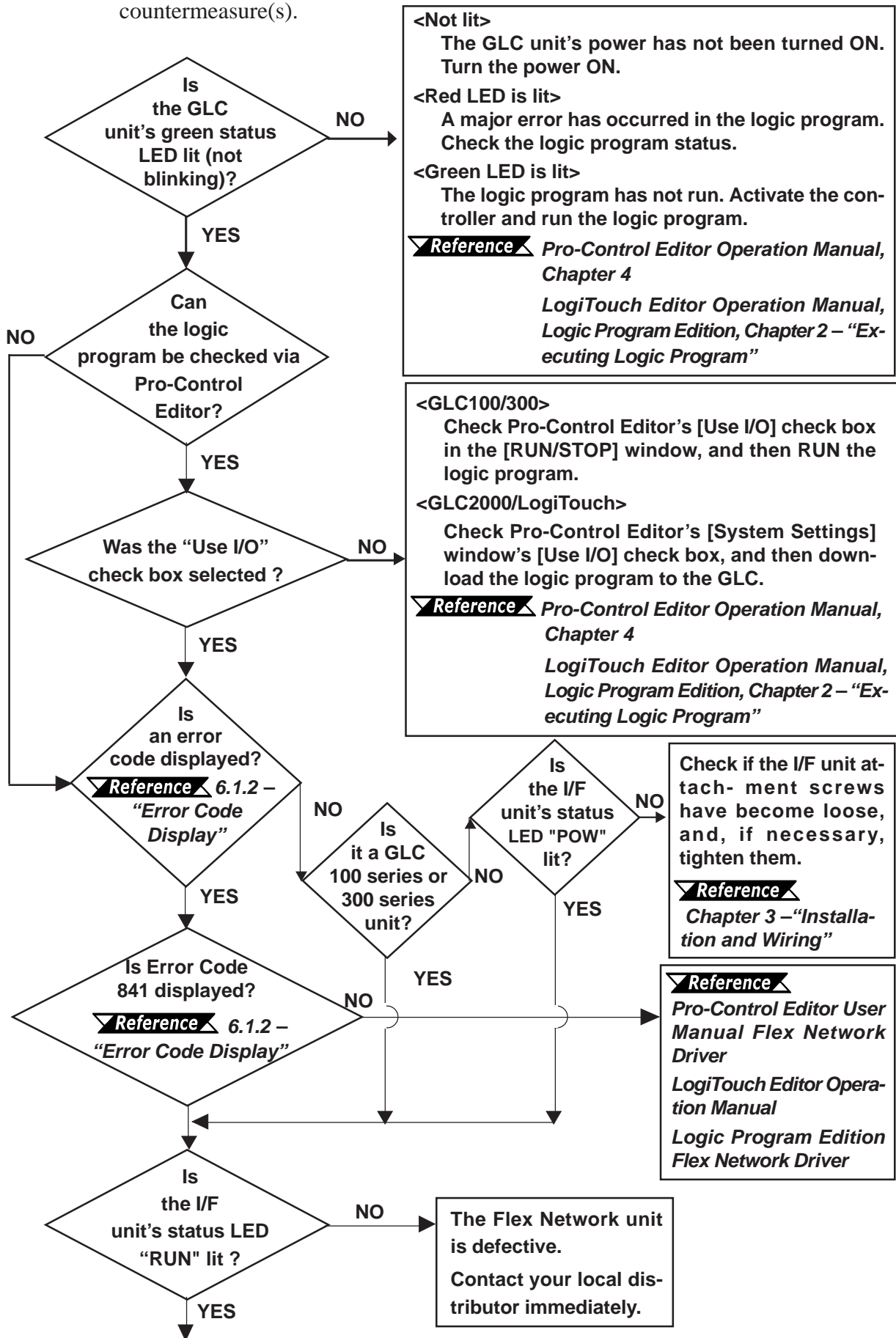

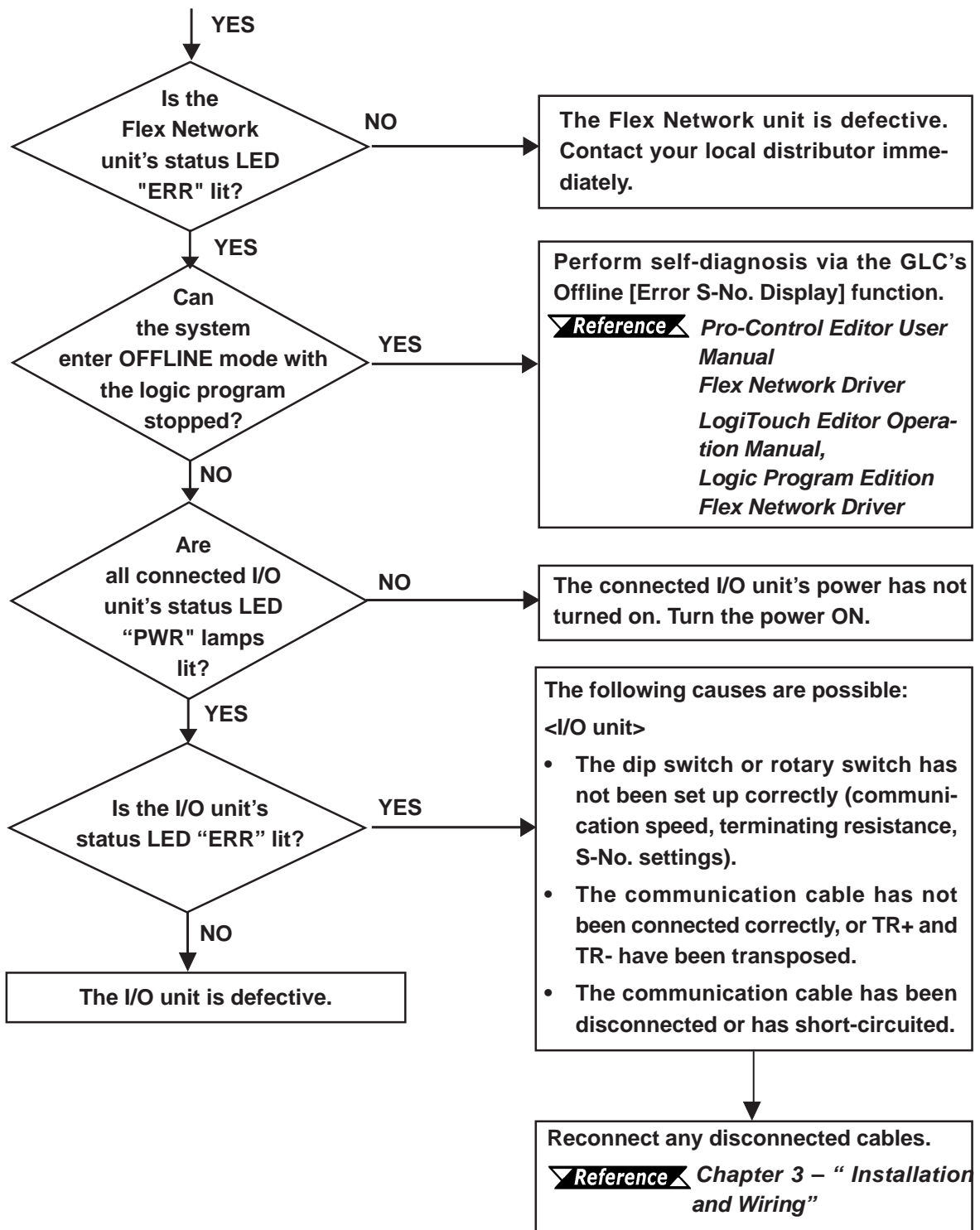

Note: It is recommended that substitute Flex Network I/F and I/O units be prepared in advance. This will allow you to minimize the amount of system downtime due to unexpected errors or problems.

INDEX

A

- Attaching a 32-Point I/O Unit 3-4
- Attachment clip 3-2

C

- CAUTIONS 5
- CE Marking 11
- Communication connector 3-6
- Communication Speed 4-4
- Communication Speed Settings 2-19
- Compatible GLC Units 8
- Crimp terminals 3-5

D

- Dimensions 2-21, 2-22, 2-23, 2-24
- DIN Rail 3-2
- Dip Switches 4-4, 2-18
- Duct for Power Lines 3-11
- Duct for Communication Lines 3-11

E

- electric shock 5
- Electrical Specifications 2-1
- Environmental Specifications 2-2
- Error Code Display 4-2
- Essential Safety Precautions 4
- Expansion Units 1-3

F

- Flex Network Data Transfer Cable 3-5
- Flex Network I/F Unit 7
- Flex Network I/F Unit Connector 2-17
- Flex Network I/F Unit Installation 3-1
- Flex Network I/F Unit Wiring 3-6
- Flex Network system 7
- Flex Network Unit Models 7

G

- General Precautions 6
- GLC 300 operator interface 1-1
- GLC Connector 2-17

H

- Handling Cautions 9

I

- I/F Unit 1-3
- I/O Cable 3-9
- I/O Unit 1-3, 1-4
- I/O Units 7
- Input Wiring 3-9
- Input/Output Circuit Drawings 2-10
- Installation 3-1, 3-2
- Installing the Unit in a Panel 3-3
- Inverters 3-11

L

- Light Emitting Diode (LED) 4-3

M

- Maintenance Items 1-4
- Maximum No. of Units 1-1

N

- Noise and Interference 3-11

O

- Optional Expansion Units 1-4
- Output Hold Settings 2-18
- Output Wiring 3-9

P

- Part Names and Features 2-17, 2-18
- Performance Specifications 2-4
- Positioning Unit 1-4
- Power Cord 3-8
- power cord terminals 3-1
- Power Surges 3-11
- Problem Solving 4-1

R

- Rotary Switch 2-18, 2-20

S

S-No. (Station Number) Setting	2-19
Safety Symbols	4
Self-Diagnosis	4-4
Set screws	3-6
Standard System Design	1-2
Status LED	2-17, 2-18
Structural Specifications	2-3
System Design	1-1

T

temperature changes	6
Terminal screws	3-6
Termination Resistance Feature	4-4
Termination Settings	2-20
Terminator	2-18
torque required	3-2
Troubleshooting	4-3
Troubleshooting Check Items	4-1

U

UL/c-UL(CSA) Approval	9
-----------------------------	---

W

WARNINGS	5
Wiring	3-5, 3-11
Wiring Layout	3-8

After-sales service

For details on after-sales service, refer to Pro-face website at <http://www.pro-face.com/trans/en/manual/1001.html>.