

# Essential Safety Precautions

## WARNINGS

### System Design

- Please design your system so that equipment will not malfunction due to a communication fault between the Factory Gateway and its host controller. This is to prevent any possibility of bodily injury or material damage.
- Do not use the Factory Gateway unit as a warning device for critical alarms that can cause serious operator injury, machine damage or production stoppage. Critical alarm indicators and their control/activator units must be designed using stand-alone hardware and/or mechanical interlocks.
- The Factory Gateway is not appropriate for use with aircraft control devices, aerospace equipment, central trunk data transmission (communication) devices, nuclear power control devices, or medical life support equipment, due to these devices' inherent requirements of extremely high levels of safety and reliability.
- When using the Factory Gateway with transportation vehicles (trains, cars and ships), disaster and crime prevention devices, various types of safety equipment, non life-support related medical devices, etc. redundant and/or fail-safe system designs should be used to ensure the proper degree of reliability and safety.

### Handling

- High voltage runs through the Factory Gateway. Never disassemble the Factory Gateway, otherwise an electric shock can occur.
- Do not modify the Factory Gateway unit. Doing so may cause a fire or an electric shock.
- Do not use the Factory Gateway in an environment where flammable gases are present, since operating the Factory Gateway may cause an explosion.

### Wiring

- To avoid an electric shock, prior to connecting the Factory Gateway's power cord terminals to the power terminal block, confirm that the Factory Gateway's power supply is completely turned OFF, via a breaker, or similar unit.
- Be sure to replace the Factory Gateway's plastic terminal block cover after wiring is completed, since operating the Factory Gateway without the cover may lead to an electric shock.
- Do not use power beyond the Factory Gateway's specified voltage range. Doing so may cause a fire or an electric shock.

### Maintenance

- The Factory Gateway uses a lithium battery for backing up its internal clock data. If the battery is incorrectly replaced, the battery may explode. To prevent this, please do not replace the battery yourself. When the battery needs to be replaced, please contact your local Factory Gateway distributor.

## CAUTIONS

### Installation

- Be sure to securely connect all cable connectors to the Factory Gateway. A loose connection may cause incorrect input or output.

### Wiring

- Ground the Factory Gateway's FG line separately from other units' FG lines. Putting these FG lines too close may cause an electric shock or unit malfunction. Be sure to use a grounding resistance of 100Ω or less and a 2mm<sup>2</sup> or thicker wire, or your country's applicable standard.
- When wiring the Factory Gateway, be sure that the rated voltage and terminal layout are within the designated range. If the voltage supplied differs from the rated voltage, or incorrect wiring or grounding is performed, it may cause a fire or unit malfunction.
- Use only the designated torque to tighten the Factory Gateway's terminal block screws. If these screws are not tightened firmly, it may cause a short-circuit, fire, or Factory Gateway malfunction.
- Be careful that metal filings and wiring debris do not fall inside the Factory Gateway, since they can cause a fire, Factory Gateway malfunction, or incorrect operation.

### Unit Disposal

- When this unit is disposed of, it should be done so according to your country's regulations for similar types of industrial waste.

### General Safety Precautions

- Do not install the Factory Gateway where the ambient temperature can exceed the allowed range. Doing so may cause the Factory Gateway to malfunction or shorten its operation life.
- Do not cover the Factory Gateway's ventilation, or store or use the Factory Gateway in an environment that is too hot.
- Do not use this unit in areas where large, sudden temperature changes can occur. These changes can cause condensation to form inside the unit, possibly causing the unit to malfunction.
- Do not allow water, liquids, metal or charged particles to enter inside the Factory Gateway, since they can cause either a Factory Gateway malfunction or an electrical shock.
- Do not use or store the Factory Gateway in direct sunlight, or in excessively dusty or dirty environments.
- Do not store or use the unit where strong jolting or excessive vibration can occur.
- Do not store or use the Factory Gateway where chemicals (such as organic solvents, etc.) and acids can evaporate, or where chemicals and acids are present in the air.  
Corrosive chemicals: Acids, alkalies, liquids containing salt  
Flammable chemicals: Organic Solvents
- Do not use paint thinner or organic solvents to clean the Factory Gateway. It may cause discoloration or the unit's malfunction.

# UL/c-UL(CSA) Application Notes

The FGW-SE41-24V is a UL/c-UL (CSA) listed product. (UL File No. E220851) When applying for UL approval for a product that includes the following Factory Gateway units, please be sure to pay special attention to the fact that all products with built-in Factory Gateway units require UL inspection of the combination of the Factory Gateway and the product.

The FGW-SE41-24V unit conforms as a product to the following standards.

- UL508 Electrical Control System for Industry
- CAN/CSA-C22.2 No.1010-1  
Safety Requirements for Electrical Equipment for Measurement, Control and Laboratory use.

FGW-SE41-24V (UL Registration Model: 3080034-01)

<Notes>

- The Factory Gateway must be installed in other equipment.
- If the unit is installed in an area with no air conditioning system, be sure that the DIN rail is attached to the rear of the unit and that the unit is vertical, so that all front face characters can be read correctly. Also, be sure the unit is installed so it is at least 100 mm away from all of the unit's directions except the rear side. If these requirements are not met, the heat generated by the unit's internal components may cause the unit to fail to meet UL standards requirements.
- The power supply unit connected to the Factory Gateway unit must be a Class 2 power supply unit or Class 2 transformer\*<sup>1</sup>. When the Factory Gateway or multiple units under load are operated with a single power supply, the amount of current consumption and full-load current of the units must be within the rated load of the Class 2 power supply unit or Class 2 power supply transformer. Be aware that the number of points which can be turned ON simultaneously may be limited, depending on the amount of load and load current value.

## CE Marking Notes

The FGW-SE41-24V is a CE Marked unit that conforms to EMC directives EN55011 Class A and EN61000-6-2.

<Caution>

While this unit is officially marked as conforming to the relevant EMC directives, it is the user's final application of this unit in a larger system (i.e. the machinery, wiring, control panel, installation method, etc.) that will determine if this unit maintains or loses this conformance marking. Therefore, it is strongly advised that the user investigate and confirm whether their overall system (i.e. all related machinery and equipment) also conforms with these EMC directives.

---

\*1 A Class 2 power supply unit or Class 2 power supply transformer is as being 30V and, at 8A or less output, less than 100VA. (defined by National Electrical Code)

# Package Contents

The following items are included in the Factory Gateway's package. Before using the Factory Gateway, please confirm that all items listed here are present.

■ **Factory Gateway Unit (1)**  
**(FGW-SE41-24V)**

■ **Installation Guide (1)**  
**<This Guide>**

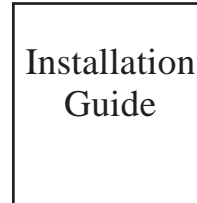
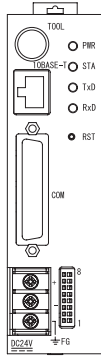

This unit has been carefully packed, with special attention to quality. However, should you find anything damaged or missing, please contact your local Factory Gateway distributor immediately.

# Options (Made by Digital)

■ **Factory Gateway  
User Manual**  
**(Sold Separately)**

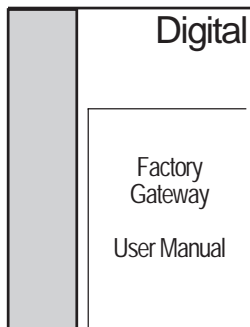

■ **Pro-Server with Pro-Studio  
for Windows Ver.4.0 or  
higher**

■ **Factory Gateway  
Configuration Tool**

■ **Maintenance Parts**

■ **Cables**

(For details about available options,  
please refer to Pro-face's Factory  
Gateway catalogs.)

# 1 Part Names

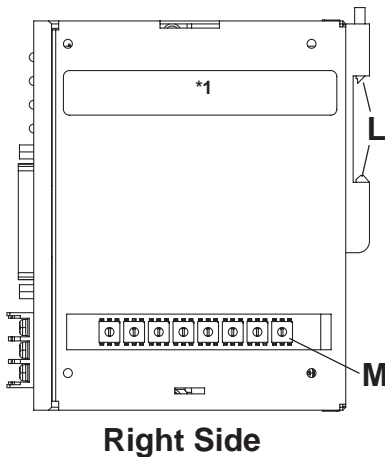
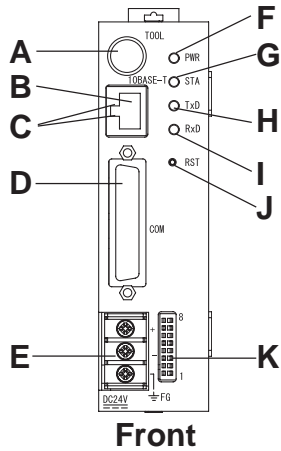

A: Tool Connector

Connect the transfer cable when transferring data for maintenance to and from the GP screen editor or using internal 2-Port features.

B: Ethernet I/F(10BASE-T)

C: Network Status LED

Two LEDs are located vertically. These LEDs reflect the transfer condition in Ethernet

Location	Lit Color	Lit Indicates	Not Lit Indicates
Upper	Green	Ready to transfer data	Not connected to network/ network trouble
Lower	Yellow	Transferring data	Not transferring data

D: Serial I/F(COM)

Used for the Dsub25 pin's RS-232C and RS-422 cables. Is connected to the Host (PLC.)

▼Reference▲ 5 Interfaces

E: Power Input Terminal Block(DC24V)

Connects the power cord.

F: Power LED (PWR)

This LED indicates the Factory Gateway's status.

LED	Factory Gateway Status
Green	Normal operation
Orange	Data transfer(Off-line) mode
Red	Initializing internal memory
Not Lit	Power off

G: Error Status LED (STA)

LED	Factory Gateway Status
Green	Normal operation
Red	System error / Screen memory data is damaged
Orange	2-Way error
Not Lit	System program error

H: Serial I/F (Tx/D)

When this indicator blinks, data is being sent.

I: Serial I/F (Rx/D)

When this indicator blinks, data is being received.

J: Reset Switch (RST)

K: DIP Switch ▼Reference▲ 4 DIP Switches

L: DIN Rail Attachment section

M: Rotary Switches ▼Reference▲ 3 Rotary Switches

\*1 This section is used only for maintenance by Pro-face. Do not open this cover.

## 2 Dimensions

Unit:mm [in.]

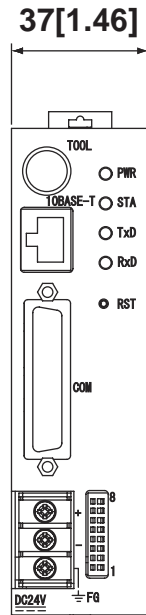

Front

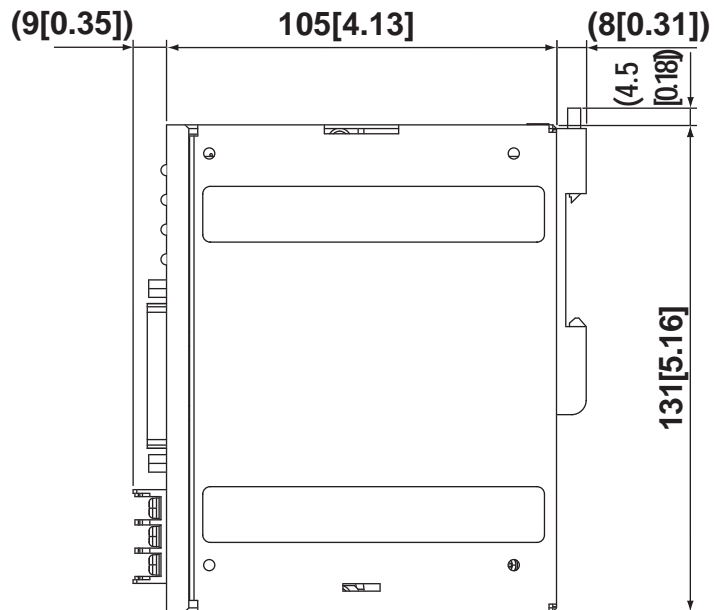

Right Side

## 3 Rotary Switches

These eight (8) rotary switches set the IP address, and are located on the right side of the Factory Gateway unit. To view these switches, open the cover.



**Note:** Be sure to set the IP address before turning the Factory Gateway ON. If you turn the Factory Gateway ON before setting the IP address (all settings are zero), a 2-Way error will occur. If this occurs, turn the power OFF, and set the IP address. Then turn the power ON again.

Factory Gateway IP addresses must be set using HEX. In the example below, the Factory Gateway's IP address is given in DEC (192.168.0.1) and HEX.

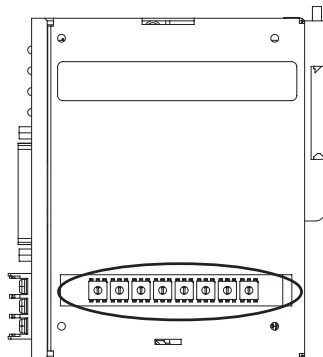

Right Side

	HEX and DEC IP Addresses			
DEC	192	168	0	1
HEX	C0	A8	00	01
Rotary Switch Settings				

Set the IP address within the following range;



**Note:** 00.00.00.01 to 7F.FF.FF.FE (0.0.0.1 to 127.255.255.254)  
 80.00.00.01 to BF.FF.FF.FE (128.0.0.1 to 191.255.255.254)  
 C0.00.00.01 to DF.FF.FF.FE (192.0.0.1 to 223.255.255.254)

## 4 DIP Switches

The Factory Gateway's DIP switches are located on the front of the Factory Gateway. The switches are numbered from one to eight, from bottom to top. The factory settings are all OFF (see below).

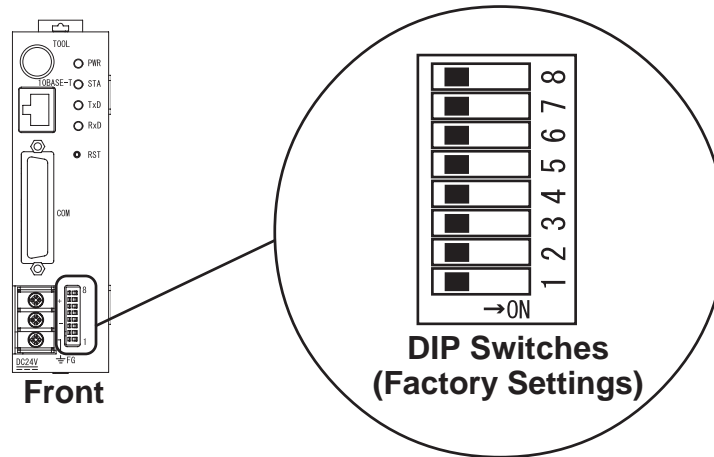

- **DIP switches are used to help the Factory Gateway recover from errors. Turning a switch ON forces that switch's feature, such as initializing internal memory, ON. To ensure the integrity of your data, please keep these switches OFF when they are not being used.**
- **Be sure to use an insulated, pointed tool to set (move) the DIP switches. Otherwise, a unit malfunction can occur.**

Switch No.	Feature	ON	OFF	Note
1	Reserved	——	——	Normally OFF
2	Reserved	——	——	Normally OFF
3	Startup transfer mode <sup>*1</sup>	Startup in transfer mode	Startup in on-line mode	
4	Initialize internal memory <sup>*2</sup>	Initialize internal memory at start up	Do NOT initialize memory at start up	
5	Enable System Data Overwrite	Overwrite Enabled	Overwrite Disabled	
6	Enable 2-Way Driver Overwrite	Overwrite Enabled	Overwrite Disabled	
7	Reserved	——	——	Normally OFF
8	Reserved	——	——	Normally OFF

*\*1 If the Factory Gateway does not enter transfer mode automatically, you can use DIP switch No.3 to force the unit to enter transfer mode. Simply set this switch to ON, and restart the unit. Be sure to set the switch back to OFF after data transfer is completed.*

*\*2 Normally, the Factory Gateway reboots the system after data transfer. If Switch No.4 is left ON, every time the Factory Gateway transfers data, internal memory's data will be initialized (deleted). After you finish using Switch No.4, be sure to set the switch to OFF before transferring data again.*



# 5 Interfaces

## Serial I/F (COM)

This interface is used to connect the Factory Gateway to the host (PLC), via an RS-232C or RS-422 cable. A socket-type Dsub -25 pin connector is used.

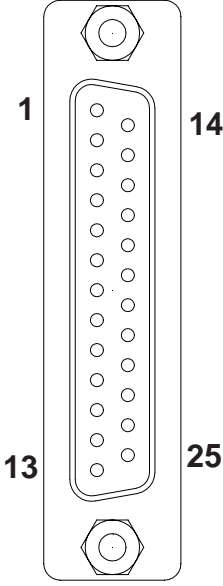
Pin Arrangement	Pin #	Signal Name	Condition
	1	FG	Frame Ground
	2	SD	Send Data (RS-232C)
	3	RD	Receive Data (RS-232C)
	4	RS	Request to Send (RS-232C)
	5	CS	Clear to Send (RS-232C)
	6	DR	Data Set Ready (RS-232C)
	7	SG	Signal Ground
	8	CD	Carrier Detect (RS-232C)
	9	TRMX	Termination (RS-422)
	10	RDA	Receive Data A (RS-422)
	11	SDA	Send Data A (RS-422)
	12	NC	No Connection(Reserved)
	13	NC	No Connection(Reserved)
	14	VCC	5V±5% Output 0.25A
	15	SDB	Send Data B (RS-422)
	16	RDB	Receive Data B (RS-422)
	17	RI	Ring Indicate (RS-232C)
	18	CSB	Clear to Send B (RS-422)
	19	ERB	Enable Receive B (RS-422)
	20	ER	Enable Receive (RS-232C)
	21	CSA	Clear to Send A (RS-422)
	22	ERA	Enable Receive A (RS-422)
	23	NC	No Connection(Reserved)
	24	NC	No Connection(Reserved)
	25	NC	No Connection(Reserved)

Recommended Connector : Dsub 25 pin plug XM2A-2501 <made by OMRON Corp.>

Recommended Cover : Dsub 25 pin Cover XM2S-2511 <made by OMRON Corp.>

Dsub 25 pin Cover XM2S-2521 <made by OMRON Corp.>

Jack Screw XM2Z-0071 <made by OMRON Corp.>

Recommended Cable : CO-MA-VV-SB5P x 28AWG <made by HITACHI Cable Ltd.>



- ***This Factory Gateway unit's serial port is not isolated. When the host (PLC) unit is also not isolated, and to reduce the risk of damaging the RS-422 circuit, be sure to connect the #7 SG (Signal Ground) terminal.***
- ***Pin #14(VCC) DC 5V Output is not protected. To prevent damage or unit malfunction, use only the designated level of current.***
- ***Inside the Factory Gateway unit, the SG (Signal Ground) and FG (Frame Ground) terminals are connected to each other.***
- ***When connecting an external device to the Factory Gateway with the SG terminal, ensure that no short-circuit loop is created when you setup the system.***





- Use rough metric type M2.6 x 0.45p threads to hold the cable's set (fastening) screws in place.
- When creating a cable, please be aware of the following:
  - <For RS-422 Connectors>
  - The following pairs of pin numbers must be connected (shorted).
    - ...#18 (CSB) <-> #19 (ERB)
    - ...#21 (CSA) <-> #22 (ERA)
  - Connecting the #9 (TRMX) and #10 (RDA) wires, adds a termination resistance of 100Ω between RDA and RDB.
  - Use a 4-wire cable when the PLC type is Memory Link and the cable is RS-422.
  - <For RS-232C Connectors>
  - Do not connect #9 (TRMX), #10 (RDA), #11 (SDA), #15 (SDB), #16 (RDB), #18 (CSB), #19 (ERB), #21 (CSA), and #22 (ERA).
  - Connect #1(FG) wire to the PLC, if necessary.

## ■ Tool Connector (TOOL)

Connect the transfer cable to this connector when transferring data for maintenance to and from the GP screen editor or using the internal 2-Port feature.

## ■ Ethernet I/F(TOOL)

This interface complies with the IEEE802.3 standard for Ethernet (10BASE-T) connections and uses an RJ-45 type modular jack connector (8 pins).

# 6 Installation

The following information explains how to attach a 35mm DIN rail to the Factory Gateway.

### ◆ Attachment

Place the unit's curved, bottom lip over the bottom of the DIN rail, and tilt the unit up until the top face attachment clip clicks into place.

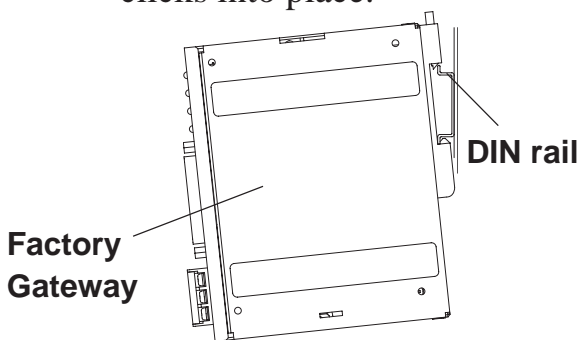

### ◆ Removal

Use a standard screwdriver to force the unit's attachment clip up until the top of the unit is freed from the rail. Next, tilt the unit down and remove.

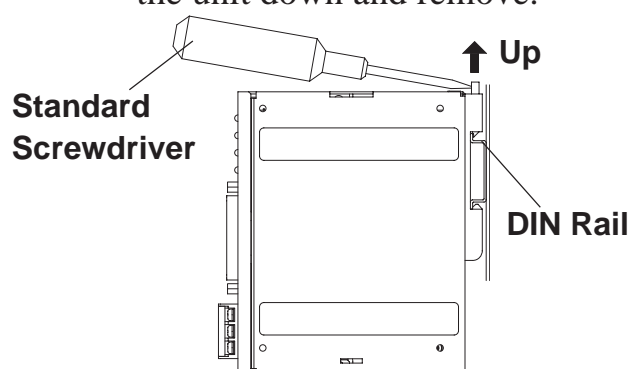

- **Be sure that the top and bottom faces of the unit are correctly oriented and that the unit is vertical. Incorrect installation may prevent heat from dissipating correctly.**
- **To prevent the Factory Gateway unit from being dislodged from the DIN Rail due to being struck or bumped from the side, the following Stabilizer Clips are recommended; BNL5P<made by IDEC Corp.>, HDV-1<made by TOYO GIKEN CO., LTD>**
- **When removing the unit from the attachment clips, hold the unit with your hand enough to prevent it from falling.**

## 7 Wiring

### WARNINGS

- To avoid an electric shock, prior to connecting the Factory Gateway's power cord terminals to the power terminal block, confirm that the Factory Gateway's power supply is completely turned OFF, via a breaker, or similar unit.
- The Factory Gateway FGW-SE41-24V unit is designed to use only DC24V input. Any other power level can damage both the Factory Gateway and the power supply.
- Since there is no power switch on the Factory Gateway unit, be sure to attach a breaker type switch to its power cord.
- When the FG terminal is connected, be sure the wire is grounded. Otherwise, an electric shock can occur when the unit is broken.



- *Wherever possible, use thick wires (max. 2 mm<sup>2</sup>) for power terminals, and twist the wire ends before attaching the ring terminals.*
- *When the FG terminal is connected, be sure the wire is grounded. Not grounding the Factory Gateway unit will result in excess noise and vibration.*
- *The SG and FG terminals are connected internally in the Factory Gateway unit.*
- *When connecting the SG line another device, be sure that the design of the system / connection does not produce a shorting loop.*



- Be sure to use the following size ring terminals.\*<sup>1</sup>
- To avoid a short caused by loose ring terminals, be sure to use ring terminals with an insulating sleeve.

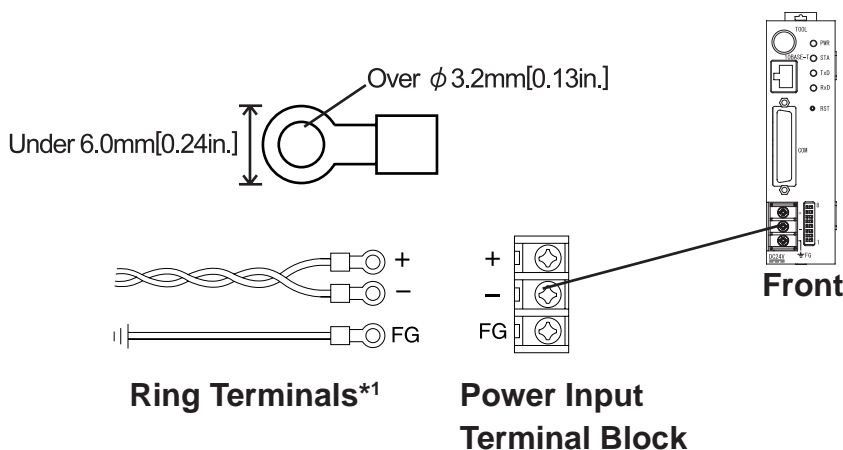

\*<sup>1</sup> Suggested Ring Terminal : V2-MS3 (made by JST)

## ■ Connecting the Factory Gateway Power Cord

When connecting the power cord, be sure to follow the procedures given below.

1. Confirm that the Factory Gateway's Power Cord is unplugged from the power supply.
2. Use a screwdriver to remove the Power Input Terminal Block's clear plastic cover.
3. Remove the screws from the middle three (3) terminals, align the Ring Terminals and reattach the screws.
4. Replace the Power Input Terminal Block's clear plastic cover.



- Confirm that the wires are connected correctly.
- The torque required to tighten these screws is 0.5 to 0.6 N•m.

---

## 8 Power Supply Cautions

Please pay special attention to the following instructions when connecting the power cord terminals to the Factory Gateway unit.

- If the power supply voltage exceeds the Factory Gateway's specified range, connect a voltage transformer.
- Between the line and the ground, be sure to use a low noise power supply.
- Input and Output signal lines must be separated from the power control cables for operational circuits.
- To increase the noise resistance, be sure to twist the ends of the power cord wires before connecting it to the Factory Gateway unit.
- The Factory Gateway's power supply cord should not be bundled with or kept close to main circuit lines (high voltage, high current), or input/output signal lines.
- Connect a surge absorber to handle power surges.
- To reduce noise, make the power cord as short as possible.

---

## 9 Grounding Cautions

- When attaching a wire to the Factory Gateway's front face FG terminal, (to the Power Input Terminal Block), be sure to create an exclusive ground.\*1
- Inside the Factory Gateway FGW-SE41-24V unit, the SG(Signal Ground) and FG(Frame Ground) terminals are connected to each other.
- When connecting the SG line to another device, be sure that the design of the system / connection does not produce a shoring loop.



***Do not use common grounding, since it can lead to an accident or machine breakdown.***

---

*\*1 Use a grounding resistance of 100  $\Omega$ , a wire of 2mm<sup>2</sup> or thicker, or your country's applicable standard.*

---

## 10 Input/Output Signal Line Cautions

- All Factory Gateway Input and Output signal lines must be separated from all operating circuit (power) cables.
- If this is not possible, use a shielded cable and ground the shield.

### Note

Please be aware that Digital Electronics Corporation shall not be held liable by the user for any damages, losses, or third party claims arising from the uses of this product.

**Digital Electronics Corporation**

8-2-52 Nanko Higashi, Suminoe-ku, Osaka 559-0031, Japan

URL: <http://www.pro-face.com/>

---

© 2002 Digital Electronics Corp.