

LT Type H Series User Manual

Preface

Thank you for purchasing the Pro-face Graphical Logic Controller unit (hereby referred to as “LT” or “LT unit”).

Please read this manual carefully, as it explains step by step how to use the LT correctly and safely.

< Notice >

1. It is forbidden to copy the contents of this manual, in whole or in part, except for the user’s personal use, without the express permission of Digital Electronics Corporation of Japan.
2. The information provided in this manual is subject to change without notice.
3. This manual has been written with care and attention to detail. However, should you find any errors or omissions, please contact Digital Electronics Corporation and inform us of your findings.
4. Please be aware that Digital Electronics Corporation shall not be held liable by the user for any damages, losses, or third party claims arising from the use of this product.

All Company/Manufacturer names used in this manual are the registered trademarks of those companies.

© Copyright 2004, Digital Electronics Corporation

Table of Contents

Preface	1
Essential Safety Precautions	5
General Safety Precautions	11
About LT Type H Series Models	13
Package Contents	13
UL/c-UL Application Notes	14
CE Marking Notes	15
Documentation Conventions	16
Separately Sold Items	16
Software Compatibility List	17

CHAPTER 1 INTRODUCTION

1.1 Prior to Operating the LT	1-1
1.2 System Design	1-2
1.2.1 System Design	1-2
1.2.2 Product Lineup	1-4
1.3 Accessories	1-6

CHAPTER 2 SPECIFICATIONS

2.1 General Specifications	2-1
2.1.1 Electrical	2-1
2.1.2 Environmental	2-1
2.1.3 Structural	2-2
2.2 Functional Specifications	2-3
2.2.1 Display	2-3
2.2.2 Memory	2-4
2.2.3 Control Memory	2-4
2.2.4 Clock	2-4
2.2.5 External Interfaces	2-4
2.3 Interface Specifications	2-6
2.3.1 DIO Connector (Type H*-AD/ADP/ADT)	2-6
2.3.2 Analog Input/Output Connector	2-12
2.3.3 Temperature Input Connector (Type H*-ADP/ADT)	2-16
2.4 Part Names and Functions	2-21

2.5	Dimensions	2-23
2.5.1	LT External Dimensions	2-23
2.5.2	Installation Fasteners	2-24
2.5.3	Panel Cut Dimensions	2-24

CHAPTER 3 INSTALLATION AND WIRING

3.1	Installation	3-1
3.1.1	Installation Procedures	3-1
3.1.2	DIO Connector Installation	3-6
3.1.3	Analog Input/Output Connector and Temperature Input Connector Installation	3-8
3.2	Wiring Cautions	3-9
3.2.1	Connecting the Power Cord	3-9
3.2.2	Grounding	3-11
3.2.3	I/O Signal Line Cautions	3-12
3.2.4	Installation Cautions	3-13
3.2.5	Connection to Pulse Motor Amplifier (CW/CCW System)	3-16
3.2.6	Connection to Pulse Motor Amplifier (Clock Up/Down System)	3-18
3.2.7	Connection Examples to Rotary Encoder	3-20
3.3	Tool Connector	3-21
3.3.1	Serial Printer Connection	3-21

CHAPTER 4 DATA TRANSFER

4.1	Data Transfer Cable	4-1
4.2	Transferring Screen Data	4-2

CHAPTER 5 OFFLINE MODE

5.1	Entering OFFLINE Mode	5-1
5.1.1	After Plugging in the Power Cord	5-2
5.1.2	From the Menu Bar	5-2
5.2	OFFLINE Mode - MAIN MENU	5-4
5.3	INITIALIZATION	5-5
5.4	SELF-DIAGNOSIS	5-7

CHAPTER 6 INITIALIZING THE LT

6.1	Initialization Screen	6-1
6.2	Initialization Items	6-2

6.3	SYSTEM ENVIRONMENT SETUP	6-3
6.3.1	SYSTEM SETUP	6-3
6.4	SET UP I/O	6-4
6.4.1	SET UP TOUCH PANEL	6-4
6.4.2	DISPLAY SETUP	6-7
6.5	OPERATION ENVIRONMENT SETUP	6-8
6.5.1	SET UP OPERATION ENVIRONMENT	6-8
6.5.2	CONTROLLER SETTINGS	6-8
6.6	INITIALIZE INTERNAL MEMORY	6-15
6.7	SET UP TIME	6-15
6.8	SET UP SCREEN	6-16
6.9	FONT SETTING	6-17

CHAPTER 7 RUN MODE AND ERRORS

7.1	RUN Mode	7-1
7.1.1	After Connecting the Power Cord	7-1
7.1.2	Via OFFLINE Mode	7-2
7.2	Troubleshooting	7-3
7.2.1	Possible Problems	7-3
7.2.2	No Display	7-4
7.2.3	Touch Panel Does Not Respond	7-7
7.2.4	Cannot Execute Logic Program	7-8
7.2.5	DIO, Analog Input, Analog Output, Temp.Input Troubleshooting .	7-9
7.2.6	Clock Settings Cannot be Entered	7-14
7.2.7	Error Screens	7-14
7.3	SELF-DIAGNOSIS	7-15
7.3.1	SELF-DIAGNOSIS ITEM LIST	7-15
7.3.2	SELF-DIAGNOSIS - Details	7-16
7.3.3	CONTROLLER SELF-DIAGNOSIS	7-18
7.4	Error Messages	7-19
7.4.1	Error Message List	7-19
7.4.2	Error Messages - Details	7-20

CHAPTER 8 MAINTENANCE

8.1	Regular Cleaning	8-1
8.1.1	Cleaning the Display	8-1
8.1.2	Installation Gasket Check / Replacement	8-1
8.2	Periodic Check Points	8-2
8.3	Replacing the Backlight	8-2

Essential Safety Precautions

This user manual contains a variety of safety markings for safe and correct operation of the LT unit. Please read this and any related manuals carefully to fully understand the correct and safe usage of the LT and its features.

■ Safety Symbols

Please pay attention to the following safety symbols and their meanings.



Indicates situations that will definitely result in severe bodily injury, death, or major machine damage if the instructions are not followed.



Indicates situations that may result in severe bodily injury, death, or major machine damage if the instructions are not followed.



Indicates situations that may result in minor bodily injury or damage to the machinery if the instructions are not followed.

DANGERS

When Designing your LT System:

- **Be sure to design your LT control system so that, in the event of a main power supply failure or an LT accident, the overall safety integrity of the user's system will be maintained. If this is not done, incorrect output signals or an LT malfunction may cause an accident.**

(1) Interlock and other circuits designed to interrupt or oppose normal machine movement (such as Emergency Stop, General Protection, and forward and reverse rotation), as well as those designed to prevent machine damage (such as upper, lower, and traverse movement limit positioning) should all be designed to be located outside of the LT.

 **DANGERS**

(2) When the LT generates a “Watchdog Timer Error,” LT operation will halt. Also, when Errors occur in Input/Output control areas that the LT cannot detect, unexpected movement may occur in those areas. Therefore, and to prevent unsafe machine movement, a “Failsafe Circuit” should be created which is completely external to the LT.

Reference 3.2.5 – “Installation Cautions”

(3) If a problem arises with an external unit’s relay or transistor that causes an output (coil) to remain either ON or OFF, a major accident can occur. To prevent this, be sure to set up external watchdog circuits that will monitor vital output signals.

- Be sure to design a circuit that will supply power to the LT unit’s I/O unit before starting up the LT. If the LT unit’s internal program enters RUN mode prior to the I/O unit’s load control power turning ON, an incorrect output (signal) or malfunction could cause an accident.
- Be sure to design a user program that ensures the safety of the user’s system, in the event of an LT display or control error, or either a data transmission error or power failure between the LT and a connected unit. These types of problems can lead to an incorrect output (signal) or malfunction, resulting in an accident.
- Do NOT use the LT as a warning device for critical alarms that can cause serious operator injury, machine damage, or production stoppage. Use stand-alone hardware and/or mechanical interlocks to design alarm indicators and their control/activator units.
- Do NOT use LT touch panel switches to perform operator safety-related or important accident-prevention operations. These operations should be performed by separate hardware switches to prevent operator injury and machine damage.

DANGERS

- Design your system so that equipment will not malfunction due to a communication fault between the LT and its host controller. This is to prevent any possibility of bodily injury or material damage.
- The LT is not appropriate for use with aircraft control devices, medical life-support equipment, central trunk data transmission (communication) devices, or nuclear power control devices, due to their inherent requirements of extremely high levels of safety and reliability.
- When using the LT with transportation vehicles (trains, cars, and ships), disaster and crime prevention devices, various types of safety equipment, and medical devices that are not life-support related, use redundant and/or failsafe system designs to ensure the proper degree of reliability and safety.

WARNINGS

- Unlike the LT unit's "Standby Mode," after the LT unit's backlight burns out, the touch panel is still active. If the operator fails to notice that the backlight is burned out and touches the panel, a potentially dangerous machine operation error can occur. Your backlight is burned out if:

- (1) your LT is not set to "Standby Mode" and the screen has gone blank
- (2) your LT is set to "Standby Mode," but touching the screen does not cause the display to reappear

To prevent an accidental machine operation error, Pro-face recommends that you use the LT unit's "USE TOUCH PANEL AFTER BACKLIGHT BURNOUT" feature, to automatically detect a burnout and disable the touch screen.

 **Reference** 6.4.3 – "Set Up Touch Panel"



WARNINGS

Installation Warnings

- High voltage runs through the LT. To prevent an electrical shock, do NOT disassemble the LT for any reason other than to replace the backlight.
- Do NOT modify the LT unit. Doing so may cause a fire or an electrical shock.
- Do NOT use the LT in an environment where flammable gases are present. Doing so may cause an explosion.

Wiring Warnings

- To prevent electrical shock or equipment damage, unplug the LT unit's power cord from the power supply prior to installing or wiring the LT.
- After completing any LT wiring work, be sure the terminal block's protective plastic cover is reattached. If this cover is not reattached, an electrical shock could easily occur.
- High voltage runs through the LT. Except for changing the backlight, do NOT attempt to open the LT, since there is a possibility of an electrical shock.
- Do NOT use power levels with the LT that are higher or lower than the LT unit's specified power range. Doing so may cause a fire, electrical shock, or LT damage.
- Do NOT operate or store the LT in areas where flammable gasses are present and may cause an explosion.

Operation and Maintenance Warnings

- NEVER touch a live power terminal. Doing so could cause an electrical shock or a machine malfunction.
- To prevent an electrical shock, unplug the LT unit's power cord before either cleaning the LT or attaching/detaching the power terminal attachment screws.



WARNINGS

- When replacing the LT unit's backlight, be sure to unplug the unit's power cord to prevent an electrical shock, and wear safety gloves to prevent burns.
- The LT uses a lithium battery to back up its internal clock and to control memory data. If the battery is incorrectly replaced (reversed positive [+] and negative [-] ends), the battery may explode. Therefore, Pro-face recommends that you contact your local LT distributor for instructions before replacing or changing the battery.
- Do not attempt to modify the LT unit's internal parts or wiring in any way, since this may lead to either electrical shock or fire.



CAUTIONS

Wiring Layout Cautions

- To prevent an LT unit malfunction due to excessive noise, isolate all LT input/output signal lines from all power wiring or power cables via a separate wiring duct.

Installation Cautions

- To reduce the risk of incorrect input or output signals, be sure that any data cables attached to the LT unit's connector make full contact with the connector pins.

General Wiring Cautions

- To prevent electrical shocks or malfunctions, be sure the LT unit's FG (earth) wire is grounded as follows:
 - (1) maximum grounding resistance: 100 Ω
 - (2) minimum grounding wire diameter: 2mm²
- The LT unit's wiring should be checked to confirm that both the operating voltage and wiring terminal locations are correct. If either the voltage or the wiring terminal location is incorrect, it can cause a fire or accident.



CAUTIONS

- Be sure to secure all wiring terminal screws with the designated torque. Screws and terminals that become loose can cause a short circuit, fire, or accident.
- Be sure that metal filings or wiring remnants do not fall inside the LT, since they can cause a fire, accident, or malfunction.

LT Operation and Maintenance Cautions

- Be sure to read the LT unit's manual and online help information carefully before performing program changes, entering forced output, or using the RUN, STOP, or PAUSE commands while the LT is in operation. Mistakes concerning the use of these items can cause a machine accident or damage.
- The liquid crystal panel contains a powerful irritant. If, for any reason, the panel is damaged and this liquid enters your eyes, flush your eyes for 15 minutes with running water and contact a physician immediately.

LT Unit Disposal Cautions

- The LT unit should be disposed of in a manner appropriate to, and in accordance with, the user country's industrial machinery disposal standards.

General Safety Precautions

- Do NOT strike the touch panel with hard or pointed objects, or press on the touch panel with too much force, since it may damage the touch panel or the display.
- Do NOT install the LT where the ambient temperature can exceed the allowed range. Doing so may cause the LT to malfunction or may shorten its operation life.
- Do NOT restrict or limit the LT unit's naturally occurring, rear-face ventilation, and do NOT store or use the LT in overheated areas.
- Do NOT store or use the LT unit in areas where large, sudden temperature changes can occur. These changes can cause condensation to form inside the unit, which can cause possible unit malfunctions.
- Do NOT allow water, liquids, metals, or charged particles to enter inside the LT unit's outer casing, since they can cause either an LT malfunction or an electrical shock.
- Do NOT store or use the LT in direct sunlight, or in excessively dusty or dirty environments.
- Do NOT store or use the LT in an environment where shaking or excessive vibration can occur.
- Do NOT store or use the LT where chemicals (such as organic solvents and acids) can evaporate, or in environments where chemicals and acids are present in the air.
 - Corrosive chemicals: acids, alkalines, liquids containing salt
 - Flammable chemicals: organic solvents
- Do NOT use paint thinner or organic solvents to clean the LT.
- Do NOT store or operate the LCD display in areas that receive direct sunlight, since the sun's ultraviolet (UV) rays may cause the quality of the LCD to deteriorate.
- Storing this unit in areas at temperatures that are lower than is recommended in this manual's specifications may cause the LCD panel's liquid to congeal, which may damage the panel. Conversely, if the storage area's temperature becomes higher than the allowed level, the LCD panel's liquid will become isotropic, causing irreversible damage to the LCD. Therefore, be sure to store the panel only in areas where temperatures are within the ranges specified in this manual.
- Due to the possibility of unexpected accidents, be sure to back up the LT unit's screen data regularly.

■ About the LT Unit's Display Panel

- The data that is currently displayed on the LT unit's screen, the screen's brightness, and the LT unit's voltage*¹ each affect the screen's intensity of **Contouring** — a wavelike pattern that is created when some parts of the screen are brighter than others.
- The minute, dark and light grid-points on the display panel's surface is part of the LT unit's design and are not defects.
- Extended shadows (*crosstalk*) may appear on the sides of screen images. This is normal for an LCD panel.
- Sometimes the display area may look as if the display colors have changed. **This is a common attribute of LCDs and is not a defect.**
- Displaying a single image for long periods of time can cause an afterimage to remain when the screen display is changed.

To prevent this effect:

- Use the LT unit's "Standby Mode," which automatically turns the screen OFF when no input is entered within a specified period of time.

▼ **Reference** ▲ 6.3.1 – "System Setup"

- Write "FFFFh" to the System Data Area's "Screen Display Off" address*² to turn the screen display OFF when the following actions are not performed within the user-specified period of time.
 - Change Screen
 - Touch Screen
 - Alarm Display
- Do NOT display any single screen for a long period of time. Try to change the screen display periodically.

*1 *Operating the LT unit in the lower range of its allowable operating voltage may affect the intensity of contouring.*

*2 *The following addresses assume all System Data Area settings are entered. If they are not all entered, the correct word address may be different, since the following addresses are relative, not fixed, addresses.*

- *With the Direct Access Method — use System Data Area word address +9*
- *With the Memory Link Method — use System Data Area word address +12*

▼ **Reference** ▲ *LT Editor Device Connection Manual (included with the LT Editor software), GP-PRO/PBIII Device/PLC Connection Manual (included with the C-Package software)*

About LT Type H Series Models

The LT Type H series refers to the following LT model numbers:

Name	Type	Model	I/O Specifications
LT Type H Series	LT Type H1 (Sink Output Type)	GLC150-BG41-ADK-24V	32-point DIO/2-point AD/1-point DA
		GLC150-BG41-ADPK-24V	32-point DIO/2-point AD/2-point DA/ 2-point Pt100 Input
		GLC150-BG41-ADTK-24V	32-point DIO/2-point AD/2-point DA/ 3-point Thermocouple Input
	LTC Type H1 (Sink Output Type)	GLC150-SC41-ADK-24V	32-point DIO/2-point AD/1-point DA
		GLC150-SC41-ADPK-24V	32-point DIO/2-point AD/2-point DA/ 2-point Pt100 Input
		GLC150-SC41-ADTK-24V	32-point DIO/2-point AD/2-point DA/ 3-point Thermocouple Input
	LT Type H2 (Source Output Type)	GLC150-BG41-ADC-24V	32-point DIO/2-point AD/1-point DA
		GLC150-BG41-ADPC-24V	32-point DIO/2-point AD/2-point DA/ 2-point Pt100 Input
		GLC150-BG41-ADTC-24V	32-point DIO/2-point AD/2-point DA/ 3-point Thermocouple Input

Package Contents

Please verify that the LT unit's packing box contains all the items listed below.

■ LT Unit (1)

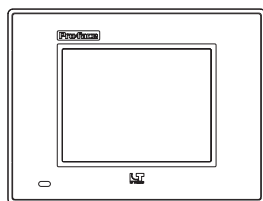

■ Installation Guide (1)

■ Installation Fasteners (4 fasteners/set)

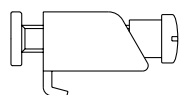

■ Installation Gasket (1)

■ LT Type H Series Connectors

- **LT Type H*-AD**
DIO connector (1) (installed)
Analog I/O connector (1) (installed)
- **LT Type H*-ADP**
DIO connector (1) (installed)
Analog I/O connector (1) (installed)
Temperature Input connector (1)
- **LT Type H*-ADT**
DIO connector (1) (installed)
Analog I/O connector (1) (installed)
Temperature Input connector (1)

Special care and attention have been given to the packaging of this LT unit. However, if any of the items are damaged or missing, contact your local LT distributor immediately for prompt service.

UL/c-UL Application Notes

The GLC150-**41-****-24V units are UL/c-UL listed products.(UL file No. E182139).

These units conform as products to the following standards:

- **UL 508, Industrial Control Equipment**
- **UL 1604, Electrical Equipment for use in Class 1 & 2 – Division 2, or Class 3 Hazardous Locations.**
- **CAN/CSA-C22.2, No. 1010-1**
(Safety requirements for electrical equipment for measurement, control and laboratory use)

GLC150-BG41-ADK-24V	(UL Registration Model: 3080061-01)
GLC150-SC41-ADK-24V	(UL Registration Model: 3280027-01)
GLC150-BG41-ADC-24V	(UL Registration Model: 3080061-02)
GLC150-BG41-ADPK-24V	(UL Registration Model: 3080061-03)
GLC150-SC41-ADPK-24V	(UL Registration Model: 3280027-03)
GLC150-BG41-ADPC-24V	(UL Registration Model: 3080061-04)
GLC150-BG41-ADTK-24V	(UL Registration Model: 3080061-05)
GLC150-SC41-ADTK-24V	(UL Registration Model: 3280027-05)
GLC150-BG41-ADTC-24V	(UL Registration Model: 3080061-06)

<Cautions>

- The LT unit must be used as a built-in component of an end-use product.
- The LT unit must be installed with the front face facing outwards.
- If this unit is installed so as to cool itself naturally, be sure to install it in a vertical panel. Also, be sure that the LT unit is mounted at least 100 mm away from any adjacent structures or equipment. If these requirements are not met, the heat generated by the LT unit's internal components may cause the unit to fail to meet UL/c-UL standard requirements.
- Separate the LT unit's power and signal lines from the main power supply via double or reinforced insulation.

UL1604 Conditions of Acceptability and Handling Cautions:

1. Power, input and output (I/O) wiring must be in accordance with Class I, Division 2 wiring methods - Article 501- 4(b) of the National Electrical Code, NFPA 70 within the United States, and in accordance with Section 18-152 of the Canadian Electrical Code for units installed within Canada.
2. Suitable for use in Class I, Division 2, Groups A, B, C and D, Hazardous Locations.
3. **WARNING:** Explosion hazard - substitution of components may impair suitability for Class I, Division 2.
4. **WARNING:** Explosion hazard - when in hazardous locations, turn power OFF before replacing or wiring modules.
5. **WARNING:** Explosion hazard - do not disconnect equipment unless power has been switched OFF, or the area is known to be free of hazards.

CE Marking Notes

The GLC150-**41-****-24V units are CE marked products that conform to EMC directives EN55011 class A and EN61000-6-2.

Conformance Standards to EMC Directives



The EN61000-6-2 standard requires that products connected to an unprotected DC line have 500V resistance (normal mode/common mode) in accordance with the 61000-4-5 surge test.

However, this LT unit's 24V Power Input for DIO and AIO connects to the DC Power line without the protection of surge resistance, which is the user's responsibility. Therefore, the surge test included in this specification is inapplicable.

This LT unit's 24V Power Input for DIO and AIO is not equipped with protection against lightning surges. Therefore, it is not lightning surge resistant. To make your LT unit or system compliant with EMC directives, connect the LT unit to surge protected power, and set up surge resistance for your LT unit or overall system. For example, when an LT unit mounted to a control panel is supplied DC24V power in accordance with the EMC directive, this LT unit's input side is protected from power surges.

Documentation Conventions

The list below describes the documentation conventions used in this manual.

Symbol	Meaning
	Indicates important information or procedures that must be followed for correct and risk-free software/device operation.
LT or LT unit	Generic term used to refer to the LT Type H Series units
LT Editor	Indicates the LT Editor software.
C-Package	Indicates Screen Creation software GP-PRO/PBIII and Logic Program Development software Pro-Control Editor.
Connected Device	Indicates peripheral devices (Temperature Controllers, Inverters, etc.), but does not include Flex Network and DIO units.
*1	Provides useful or important supplemental information.
	Provides useful or important supplemental information.
	Cross-references to useful or important supplemental information.

Separately Sold Items

■ Logic Program Development Software

- **LT Editor Software**

If you are using a previous version of this software, you will need to update to version 2.0. This module can be downloaded from Pro-face's home page.

<http://www.pro-face.com>

- **GP-PRO/PBIII C-Package03**

* The software that can be used will vary depending on the type of unit.

 *Software Compatibility List*

■ LT Type H I/O Setting User Manual

Explains I/O setting information for DIO, Analog I/O, temperature input units and others.

Software Compatibility List

LT Type H Series operator interfaces can use either of the following software packages to create screens and logic programs.

- GP-PRO/PBIII C-Package03 or later
- LT Editor Ver. 2.0



LT color-type operator interfaces can only use GP-PRO/PBIII C-Package03 or later software. LT Editor software cannot be used.

Please be sure to read the following table prior to creating your screens and logic programs, as the software that can be used will vary depending the unit model.

Model Number	LT Editor Ver. 2.0	C-Package03 or later
GLC150-BG41-ADK-24V	O	O
GLC150-SC41-ADK-24V	X	O
GLC150-BG41-ADPK-24V	O	O
GLC150-SC41-ADPK-24V	X	O
GLC150-BG41-ADTK-24V	O	O
GLC150-SC41-ADTK-24V	X	O
GLC150-BG41-ADC-24V	O	O
GLC150-BG41-ADPC-24V	O	O
GLC150-BG41-ADTC-24V	O	O

Memo

Chapter 1 Introduction

1. Prior to Operating the LT
2. System Design
3. Accessories

1.1 Prior to Operating the LT

Use the following steps when creating projects for the LT unit.

- 1. Preparation** – Before using the LT, be sure that you have all required hardware and have read all specification, wiring, and installation information.
Reference *Chapters 2 and 3 – “Specifications” and “Installation and Wiring”*
- 2. Design** – Design your LT screens and create a logic program.
- 3. Install the LT Editor/C-Package** – Install the LT Editor/C-Package software in your PC.
Reference *LT Editor CD Jacket, C-Package CD Jacket*
- 4. Develop Logic Program** – Use the LT Editor/C-Package software to develop a logic program and set the operation mode.
Reference *LT Editor Operation Manual – Logic Programming Guide, Pro-Control Editor Operation Manual/User Manual*
- 5. I/O Settings for DIO, High-Speed Counter, and Analog I/O** – Use the LT Editor/C-Package software to set up the I/O settings for DIO, High-Speed Counter, and analog input/output.
Reference *LT Type H I/O Setting User Manual.*
- 6. Create Screen / Run Screen Setup** – Use the LT Editor/C-Package software to set up the screen and parts according to your screen design.
Reference *LT Editor Operation Manual – Screen Creation Guide, GP-PRO/PBIII Operation Manual (included with the C-Package software)*
- 7. Transfer Screen Data and Logic Program** – Use the LT Editor/C-Package software to transfer your screen data and logic program to the LT unit.
Reference *LT Editor Operation Manual – Screen Creation Guide, GP-PRO/PBIII Operation Manual (included with the C-Package software)*
- 8. Monitor Logic Program** – Use the LT Editor/C-Package software's monitor feature to check that your logic program operates correctly.
Reference *LT Editor Operation Manual – Logic Programming Guide, Pro-Control Editor Operation Manual (included with the C-Package software)*
- 9. Initialize** – Set up the LT unit's Initial Settings according to your operation needs.
Reference *Chapter 5 – “Initializing the LT”, LT Editor Device Connection Manual and GP-PRO/PBIII Device/PLC Connection Manual (included with the C-Package software)*
- 10. Operation** – Connect the LT to an external device and begin operation.
Reference *LT Editor Device Connection Manual, GP-PRO/PBIII Device/PLC Connection Manual (included with the C-Package software)*



Note:

Each LT Editor/C-Package manual referenced above is included with the LT Editor / C-Package software, and is also available as a PDF file on the CD-ROM.

1.2 System Design

1.2.1 System Design

The following table shows the LT Type H units, which consist of sink output and source output types, and are categorized as AD, ADP, and ADT – depending on the I/O specifications.

Name	Type	Model	I/O Specifications
LT Type H Series	LT Type H1 (Sink Output Type)	GLC150-BG41-ADK-24V	32-point DIO/2-point AD/1-point DA
		GLC150-BG41-ADPK-24V	32-point DIO/2-point AD/2-point DA/ 2-point Pt100 Input
		GLC150-BG41-ADTK-24V	32-point DIO/2-point AD/2-point DA/ 3-point Thermocouple Input
	LTC Type H1 (Sink Output Type)	GLC150-SC41-ADK-24V	32-point DIO/2-point AD/1-point DA
		GLC150-SC41-ADPK-24V	32-point DIO/2-point AD/2-point DA/ 2-point Pt100 Input
		GLC150-SC41-ADTK-24V	32-point DIO/2-point AD/2-point DA/ 3-point Thermocouple Input
	LT Type H2 (Source Output Type)	GLC150-BG41-ADC-24V	32-point DIO/2-point AD/1-point DA
		GLC150-BG41-ADPC-24V	32-point DIO/2-point AD/2-point DA/ 2-point Pt100 Input
		GLC150-BG41-ADTC-24V	32-point DIO/2-point AD/2-point DA/ 3-point Thermocouple Input

Depending on your LT unit's built in features, the following types of systems can be created.

■ DIO System Example (H*-AD/ADP/ADT)

The LT unit allows you to control ON/OFF using various types of I/O devices, stepping motors, and incremental encoders.

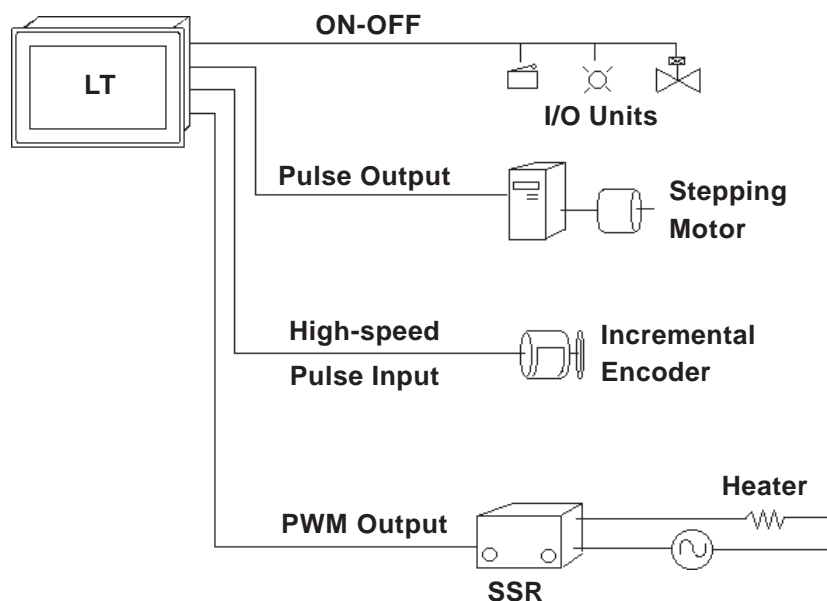

■ Analog I/O and Temperature Input System (H*-ADP/ADT)

The following is an example of an application that adjusts how well fish is cooked in a tunnel furnace. The speed instruction is sent to the inverter using analog data, and the conveyer's speed is adjusted accordingly.

To maintain the temperature of the tunnel furnace at the preset value, the heater is controlled by SSR, and the PMW output is controlled by the PID instruction.

The correlation between temperature and current input can be obtained by displaying the current values of the heater with a trend graph, which will detect heater disconnection.

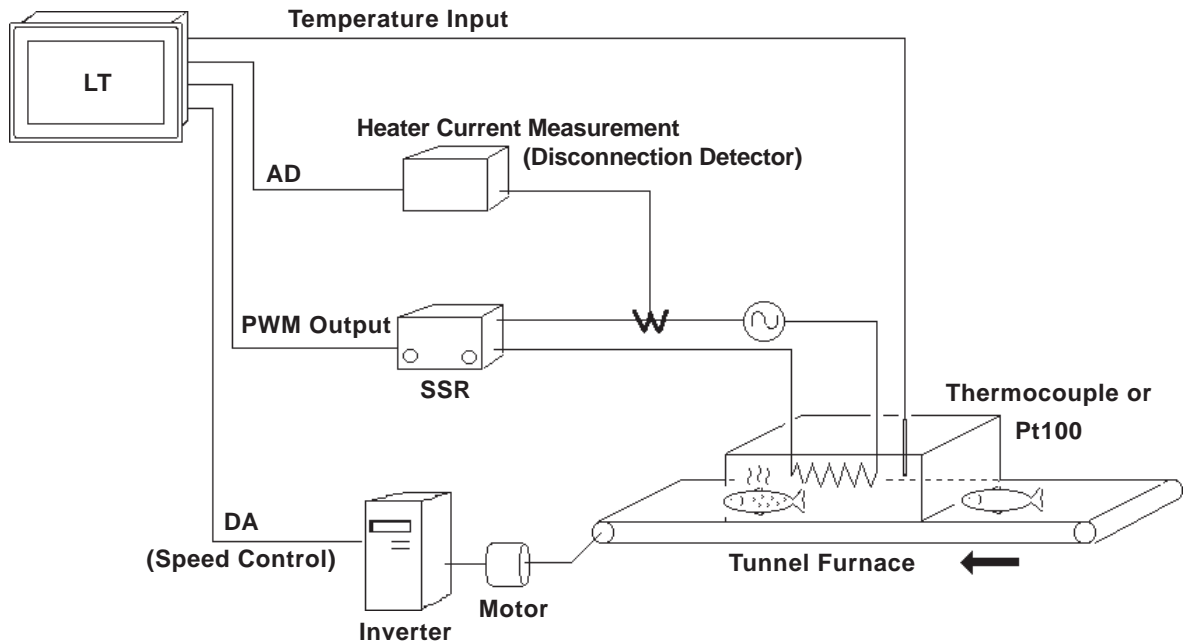

Chapter 1 – Introduction

1.2.2 Product Lineup

The following diagram represents the main selection of devices that can be connected to the LT.

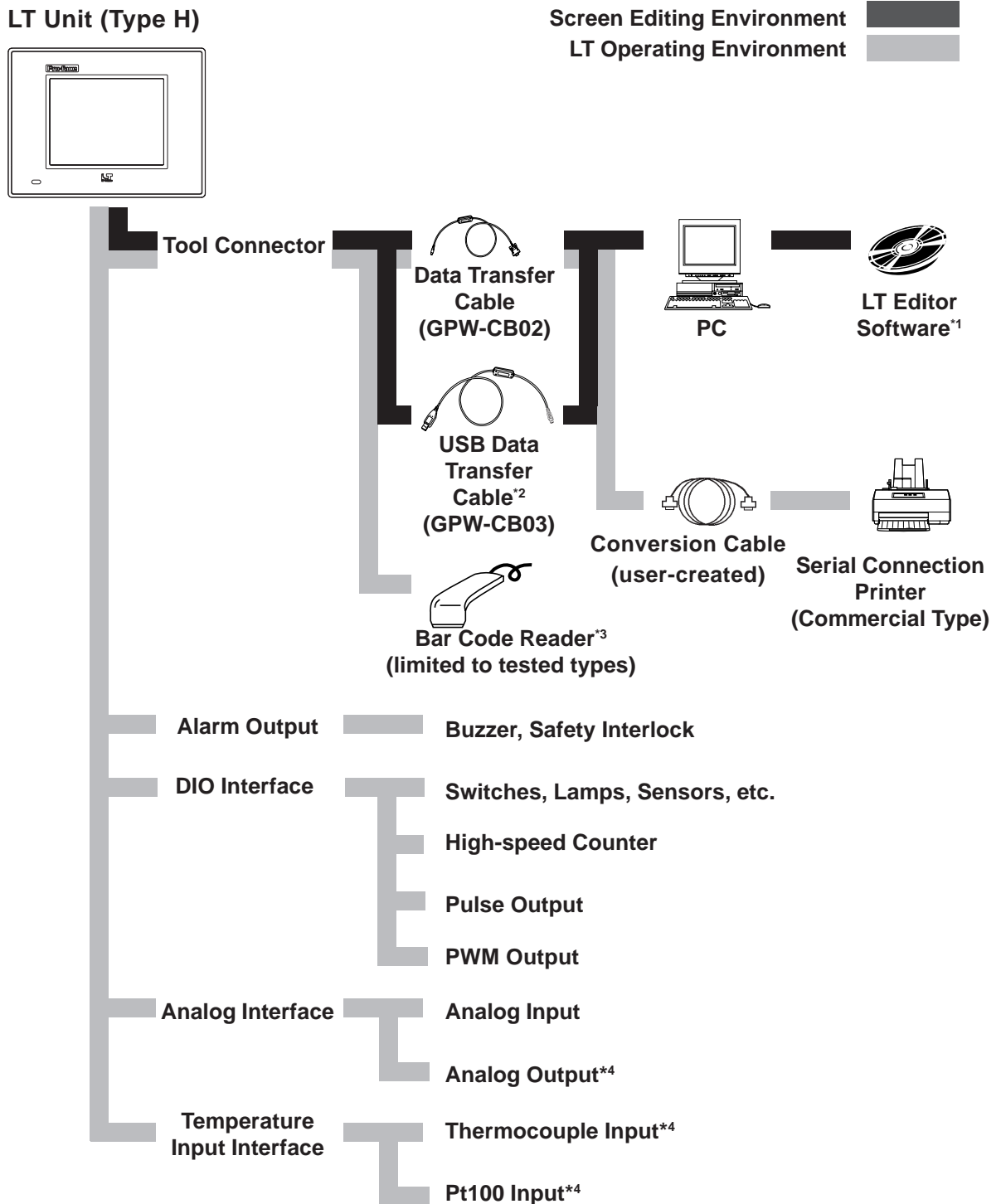

*1 The software that can be used will vary depending on the type of unit.

Reference Software Compatibility List

*2 Software version limitations apply.

Reference For details, USB Data Transfer Cable Installation Guide.

*3 See Page 1-5 for recommended units.

*4 Depending on the model of the LT Type H unit used, I/O specifications may differ.

■ Recommended Units

The following tables list I/O devices that have been confirmed to be compatible with the LT. If you connect a device other than those listed below, be sure to confirm that the connection functions correctly using an actual unit.



Recommended units are subject to change without notice.

Bar code readers (Connected to Tool Connector)

NEC Infrontia	BCK5435-STA	Touch Scanner (Read Width: 56mm) ^{*1*2}
	BCK5535-STA	Touch Scanner (Read Width: 85mm) ^{*1*2}

*1 *Be sure to use the Y cable included with the unit and connect it between the LT unit and a bar code reader. Data cannot be read correctly if a non-"Y" cable is used, or if the bar code reader is connected directly to the LT unit.*

*2 *The following settings must be entered prior to using the bar code reader with an LT unit.*

1) Select CAPS.

2) Add the Carriage Return (CR) in the Postamble's settings.

For the details about these settings, please refer to the Installation Guide included with the bar code reader unit.

1.3 Accessories

The following items are optional LT products (sold separately).

■ Available Software*¹

Product Name	Model No.	Description
LT Editor V2.0	GLCLT-ED01W-V20	Software used to create the LT unit's screen data and to develop a logic program.
C-Package03 or later	GPPRO-CNT03W-P03	

1 The software that can be used will vary depending on the type of unit.

Reference *Software Compatibility List*

■ Tool Connector

Product Name	Model No.	Description
Data Transfer Cable	GPW-CB02	Connects the LT to a PC; transfers screen data and user ladder logic program(s).
USB Data Transfer Cable ¹	GPW-CB03	

1 Software version limitations apply.

Reference *For details, USB Data Transfer Cable Installation Guide.*

■ Optional Items

Item	Model No.	Description
Screen Protection Sheet (5 sheets/set)	GP37W2-DF00	Disposable protective and dirt-resistant sheet for the LT unit's screen. The LT unit's touch panel can be used with this cover sheet attached.

■ Optional Maintenance Items

The following items are included in the LT unit's packing box, and are also sold separately.

Product Name	Model No.	Description
Installation Fastener (4 fasteners/set)	GP070-AT01	Fasteners that attach the LT to a panel.
Installation Gasket	GP37W2-WP00-MS	Provides a moisture-resistant seal when installing the LT. Same as the seal included in the LT unit's original equipment package.
DIO Connector (2-pack)	GLC-DIOCN04	Connector that attaches the LT to the DIO I/F
Analog I/O Connector (5-pack)	GLC-AIOCN01	Connector that attaches the LT to Analog I/F
Temperature Input Connector (5-pack)	GLC-TMCN01	Connector that attaches the LT to the Temperature Input I/F

Chapter

2 Specifications

1. General Specifications
2. Functional Specifications
3. Interface Specifications
4. Part Names and Functions
5. Dimensions

2.1 General Specifications

2.1.1 Electrical

Rated Voltage	DC 24V
Voltage Supply Range	DC 20.4V to DC 28.8V
Allowable Voltage Drop	10 ms max.
Power Consumption	20 W max.
In-Rush Current	30 A max.
Voltage Endurance	AC 1000V at 10 mA for 1 minute (between VCC and FG terminals)
Insulation Resistance	DC 500V at 20 MΩ or higher (between VCC and FG terminals)

2.1.2 Environmental

Ambient Operating Temperature (Panel face and interior)	0°C to +50°C
Storage Temperature	-20°C to +60°C
Ambient Humidity	10%RH to 90%RH (non-condensing, wet bulb temp.: 39°C max.)
Storage Humidity	10%RH to 90%RH (non-condensing, wet bulb temp.: 39°C max.)
Air Purity (Dust)	0.1mg/m ³ max. (non-conductive levels)
Atmosphere	Pollution Degree 2
Corrosive Gasses	Free of corrosive gases
Atmospheric Pressure (LT Operation Altitude)	800hPa to 1,114hPa (2000 meters max.)
Vibration Resistance	IEC61131-2 (JIS B 3502) compliant When Vibration is NOT Continuous 10Hz to 57Hz 0.075mm, 57Hz to 150Hz 9.8m/s ² When Vibration is Continuous 10Hz to 57Hz 0.035mm, 57Hz to 150Hz 4.9m/s ² 10 times (80 min.) for each (X, Y, Z) direction
Shock Resistance	IEC61131-2 (JIS B 3502) compliant 147m/s ² - T twice for each (X,Y,Z) direction.
Noise Immunity (via noise simulator)	Noise Voltage: 1500Vp-p ^{*1} Pulse Duration: 1μs Rise Time: 1ns
Electrostatic Discharge Immunity	Contact Discharge Method 6kV (complies with IEC 61000-4-2 Level 3)

*1 PWM Pulse output becomes 1000Vp-p.

Chapter 2 – Specifications

2.1.3 Structural

Grounding	100 Ω max., or your country's applicable standard ^{*1}
Ratings ^{*2}	Equivalent to IP65f (JEM 1030), NEMA #250 TYPE 4X/12
External Dimensions	W207 x H157 x D75.8 mm [W8.15 x H6.18 x D2.98 in.]
Weight	1.5 kg (3.3 lb) max.
Cooling Method	Natural air circulation

**1 Grounding requirements differ from country to country. Confirm the requirements of your work environment prior to installation.*

**2 The front face of the LT unit is installed in a solid panel and has been tested under conditions equivalent to the standards listed in the specifications. The LT unit's level of resistance is equivalent to these standards; however, oils that should have no effect on the LT can harm the unit — when vaporized oils are present, when low-viscosity cutting oils are allowed to adhere to the unit for long periods of time, or if the protective sheet on the front face of the LT peels off. These conditions can lead to the ingress of oil into the LT, and alternate protective measures are recommended. Also, the presence of non-approved oils may cause deformation or corrosion of the front panel's plastic cover. Therefore, prior to installing the LT, confirm the type of conditions that will be present in the LT unit's operating environment. If the installation gasket is used for a long period of time, or if the unit and its gasket are removed from the panel, the original level of the protection cannot be guaranteed. To maintain the original protection level, replace the installation gasket regularly.*

2.2 Functional Specifications

2.2.1 Display

	GLC150-BG41-***-24V	GLC150-SC41-***-24V
Type	Monochrome LCD	STN Color LCD
Resolution	320x240 pixels	
Effective Display Area	W115.2 x H86.4 mm [W4.54 x H3.40 in.]	W118.2 x H89.4 mm [W4.65 x H3.52 in.]
Colors	Blue mode (monochrome)	64 colors
Backlight	CFL (lifespan: more than 25,000 hours when continuously lit)	CFL (lifespan: more than 36,000 hours when continuously lit)
Contrast Adjustment Control	8 levels of adjustment available via touch panel.	
Language Fonts	ASCII: (Code page 850) Alphanumeric (incl. Eur. characters) China: (GB2321 – 80 codes) simplified Chinese fonts Japan: ANK158, Kanji: 6962 (JIS Standards 1& 2) Korea: (KSC5601 – 1992 codes) Hangul fonts Taiwan: (Big 5 codes) traditional Chinese fonts	
Touch Panel Resolution	16x12 grid of touch panel keys (1 or 2 point touch)	
Text	8x8 dots	40 Char. x 30 rows
	8x16 dots	40 Char. x 15 rows
	16x16 dots	20 Char. x 15 rows
	32x32 dots	10 Char. x 7 rows
Display Sizes^{*1}	8X8 dot font, 8X16 dot font, 16X16 dot font, and 32X32 dot font	
Font Sizes	Both height and width can be expanded 1, 2, 4, or 8 times.	

**1 The display font will differ depending on which (language) character or size you select.*

Reference 6.9 – “Font Setting”

Chapter 2 – Specifications

2.2.2 Memory

Application	1 MB FLASH EPROM (Approx. 320 screens at 3.2 KB/screen)
Data Backup	96 KB SRAM (uses lithium secondary battery) ^{*1}

2.2.3 Control Memory

Variable Area	32 KB SRAM (uses lithium secondary battery) ^{*1}
Program Area	128 KB FLASH EPROM

*1 *A Lithium secondary battery's lifetime is:*

- 10 years when the battery's ambient temperature is less than 40° C
- 4.1 years when the battery's ambient temperature is less than 50° C
- 1.5 years when the battery's ambient temperature is less than 60° C

When used for backup - assuming 96 hours (4 days) to charge fully:

- Approximately 60 days with a fully-charged battery
- Approximately 6 days with a half-charged battery

2.2.4 Clock

Clock Accuracy	±65 seconds/month (at room temperature)
-----------------------	---



Note:

The LT unit's internal clock has a slight degree of error in accuracy. At normal operating temperatures and conditions, and with the LT operating from its lithium battery, the degree of error is ±65 seconds per month. Variations in operating conditions and battery life can cause this error to vary from -380 to +90 seconds per month. For systems where this degree of error will be a problem, the user should monitor this error and make adjustments as required.

2.2.5 External Interfaces

■ Tool Connector (Type H*-AD/ADP/ADT)

Tool Connector	Asynchronous TTL level nonprocedural command Interface During Screen File (HMI interface) Development: <ul style="list-style-type: none">• used to transfer data between the LT/C-Package software and the LT unit During Operation: <ul style="list-style-type: none">• used for a variety of devices, including a bar-code reader
-----------------------	--

■ Alarm Output for Circuit (Type H*-AD/ADP/ADT)

Turning the LT unit ON will start the unit’s system software and the alarm output circuit’s relay. When a major error triggers a watchdog alarm, however, this relay will turn OFF. Since an undefined LT input or output condition can occur, be sure to design an external failsafe circuit that will monitor the output of this relay.

Contact Rating	0.15A – AC 125V Resistance Load 0.6A – DC 24V Resistance Load
Operating Time (Set Time at 20°C)	4ms max.
Recovery Hours (Reset Time is set at 20°C)	4ms max.
Minimum Switching Load	1mA / DC 5V
Initial Contact Resistance	100mΩ max.

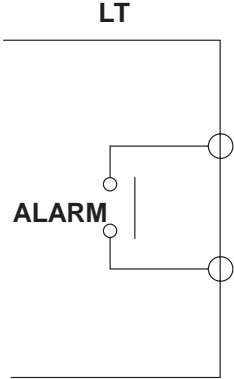

◆ Recommended Wire

Terminal block screw fastening torque : 0.22 to 0.25 N•m
 Maximum wire size : 1.3 mm (AWG#16), Applicable to UL1015 or UL1007
 Wire strip length : 5.0 mm [0.2 in.]



When the LT unit is started up, the Alarm output is turned OFF for 1 second. If the LT unit’s Alarm output is being monitored externally, be sure to design the system so that a halt of 1 second is ignored.

◆ OMRON Corporation Timer H3CR-A Circuit Drawing

This Circuit uses an H3CR-A terminal number.

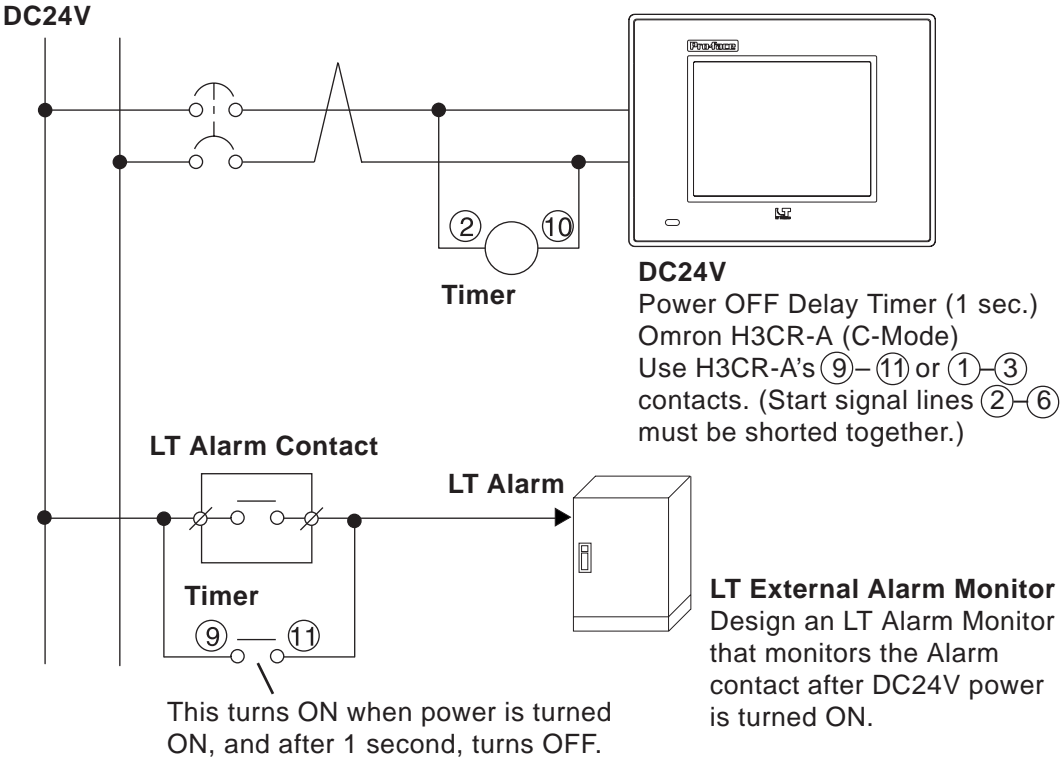

2.3 Interface Specifications

2.3.1 DIO Connector (Type H*-AD/ADP/ADT)

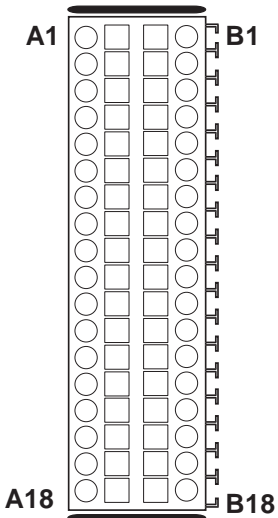
Pin Assignments	Pin #	Signal Name	Pin #	Condition
	A1	OUT15	B1	IN15
	A2	OUT14	B2	IN14
	A3	OUT13	B3	IN13
	A4	OUT12	B4	IN12
	A5	OUT11	B5	IN11
	A6	OUT10	B6	IN10
	A7	OUT9	B7	IN9
	A8	OUT8	B8	IN8
	A9	COM3	B9	COM1
	A10	OUT7	B10	IN7
	A11	OUT6	B11	IN6 (CT3)
	A12	OUT5	B12	IN5
	A13	OUT4	B13	IN4 (CT2)
	A14	OUT3 (PLS3, PWM3)	B14	IN3
	A15	OUT2 (PLS2, PWM2)	B15	IN2 (CT1)
	A16	OUT1 (PLS1, PWM1)	B16	IN1
	A17	OUT0 (PLS0, PWM0)	B17	IN0 (CT0)
	A18	COM2	B18	COM0



Parentesized signal names () indicate when Pulse output (PLS*), PWM output (PWM*), or Counter Input (CT*) are used.

◆ Recommended Connector and Wire

B2L3.5/36LH 36 pole spring-clamp connector (Weidmuller)

Connectable wire size : 0.3 to 1.0 mm (AWG#22 to AWG#18, Lay wire)

Applicable to UL1015 or UL1007

Wire strip length : 6.5 to 8.0 mm [0.26 in. to 0.31 in.]



The terminals for DIO power supply are located on the analog input/output connector.

◆ About COM

Pin Number	Signal Name	Function
B18	COM0	Input Common (For IN0 to IN7) (For CT0 to CT3)
B9	COM1	Input Common (For IN8 to IN15)
A18	COM2	Output Common (For OUT0 to OUT7) (For PLS0 to PLS3, PWM0 to PWM3)
A9	COM3	Output Common (For OUT8 to OUT15)

■ DIO Specifications

◆ Input Specifications

Rated Voltage	DC 24V
Max. Allowable Voltage	DC 28.8V
Input Method	Source/Sink Input
Rated Current	9 mA (DC24V) (IN0, IN2, IN4, IN6) 5 mA (DC24V) (Other input)
Input Impedance	Approx. 2.7 k Ω (IN0, IN2, IN4, IN6) Approx. 4.7 k Ω (Other input)
Input Derating	Reference ■ "Input Derating" (see below)
Operation Range	ON Voltage: DC19V min. OFF Voltage: DC5V max.
Input Delay Time	OFF to ON: 0.5 to 20ms max.*1 ON to OFF: 0.5 to 20ms max.*1
Common Lines	2
Common Lines Allocation	8 points/1 common line
Input Points	16
Input Signal Display	LED lights when each point turns ON (logical side)
Isolation Method	Photocoupler Isolation
Polarity	None
External Power Supply	For Signal: DC 24V

*1 The digital filter can be set using 0.5ms intervals.

Input Derating

Exceeding the LT unit's input rated voltage may affect the input ON voltage, input points, or ambient operating temperature; and the unit's input terminals may be damaged due to excessive heat. Use Input Derating within the range shown in the chart below, to prevent LT unit damage.

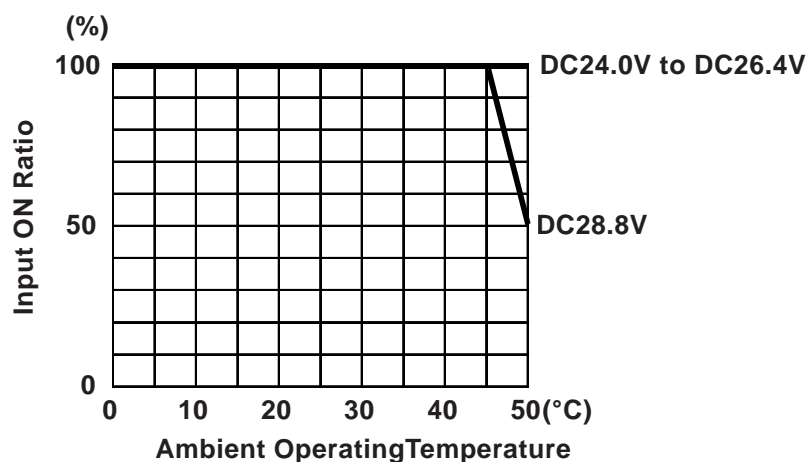

Chapter 2 – Specifications

◆ Output Specifications

	LC (Low Current) OUT0 to OUT7	HC (High Current) OUT8 to OUT15
Rated Voltage	DC 24V	
Rated Voltage Range	DC 20.4V to DC 28.8V	
Output Method	Type H1 Sink Output	
	Type H2 Source Output	
Maximum Load Current	0.2 A/point 0.8 A/common	0.5 A/point 2 A/common
Output Voltage Drop	0.5V max.	
Output Delay Time	OFF to ON: 0.5 ms max	
	ON to OFF: 0.5 ms max.	
Current Leakage (when OFF)	0.1 mA max.	
Type of Output	FET Transistor Output	
Common Lines	1	
Common Design	8 points/1 common line	
Output Protection Type	Output is unprotected	
Internal Fuse	2A Chip Fuse	5A Chip Fuse
	(non-replaceable)	(non-replaceable)
Surge Control Circuit	Zener Diode (DC39V±1V)	
Output Signal Display	LED lights when each point turns ON (logical side)	
Isolation Method	Photocoupler Isolation	
External Power Supply	For signal: DC 24V	

◆ Type H1-AD/ADP/ADT Input/Output Circuit
(Sink IN and Source IN/Sink OUT)

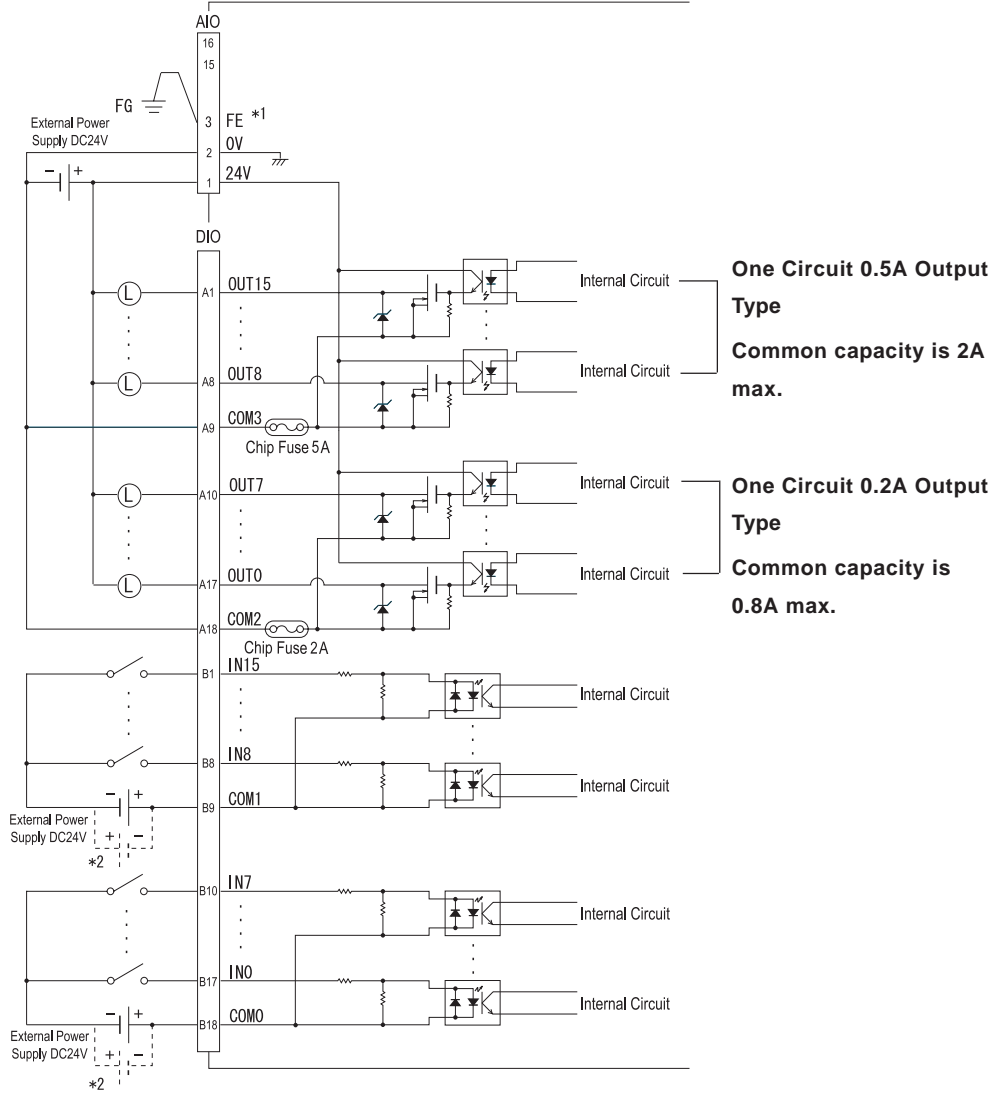

*1 Ground this wire when noise or other problems occur during unit operation.
*2 The dotted line circuit is used for the Source IN circuit



When using an external power supply's transistor output, if a switch is inserted in the power line, be sure to insert it in the DC power line's AC input side.

When a switch is inserted between external DC power and transistor output, turning the switch from ON to OFF, the output transistor will briefly (less than 0.1ms) turn ON, and can lead to a malfunction. Also, when power is turned ON, the amount of in-rush current will be large.

Chapter 2 – Specifications

◆ Type H2-AD/ADP/ADT Input/Output Circuit (Sink IN and Source IN/Source OUT)

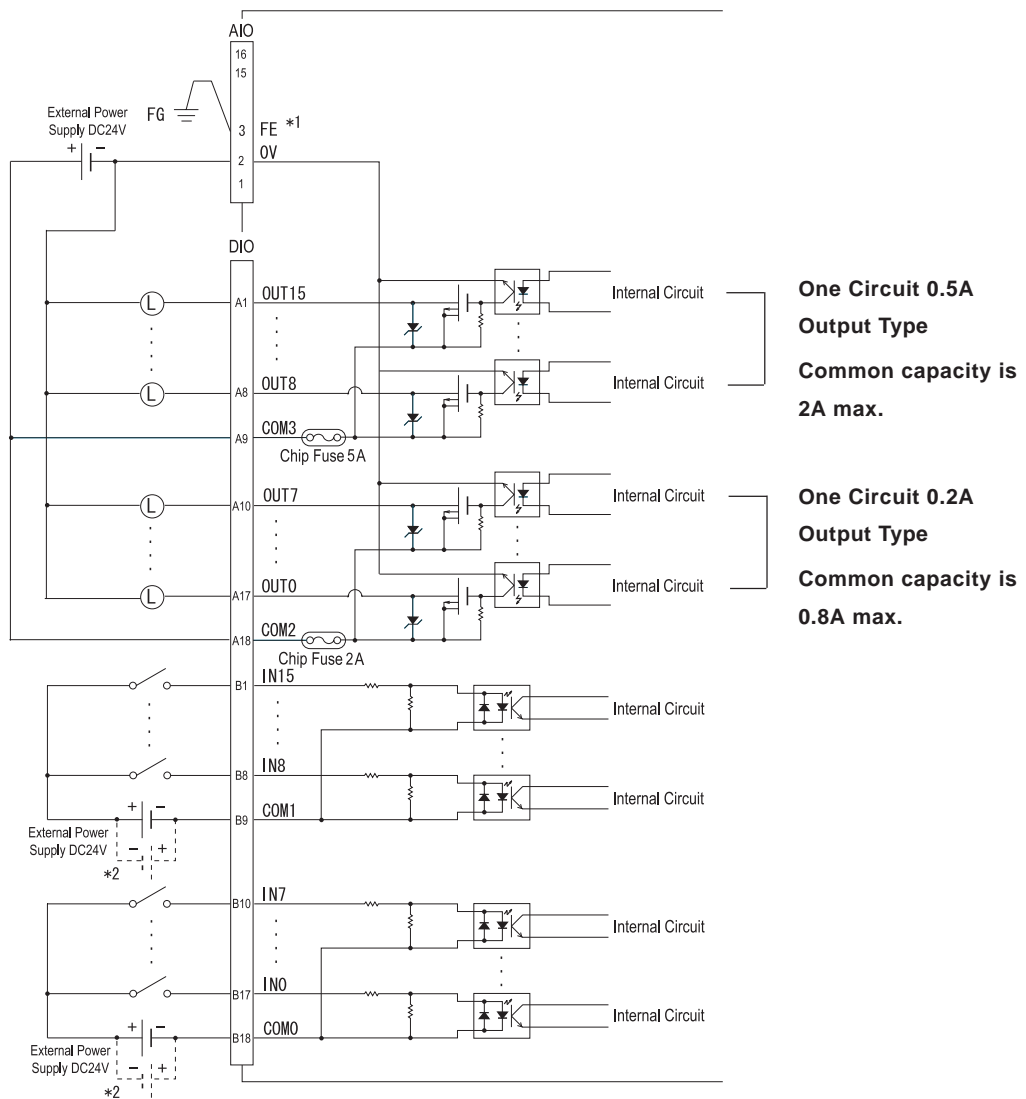

*1 Ground this wire when noise or other problems occur during unit operation.

*2 The dotted line indicates the Sink IN circuit.

■ High-Speed Counter Input Specifications

DIO can be used as a high-speed counter input. The setup is done by the LT Editor/C-Package.

▼Reference▲ *LT Type H Series I/O Setting User Manual*

Counter Input	DC 24V (Open Collector)	
	Single Phase (4 points)	2-Phase (one point)
Counter Input Method	CT0(IN0), CT1(IN2), CT2(IN4), CT3(IN6)	CT0(IN0), CT1(IN2) are used as a pair CT0: A Phase, CT1: B Phase
Input Voltage	ON Voltage: DC19V min. OFF Voltage: DC5V max.	
Input Impedance	2.7 k Ω	
Minimum Pulse Width (Pulse Input)		
Calculated Speed (Rise and Fall time)		
Phase	1 phase	90 degree phase differential-2 phase signal; 1 phase+directional signal
Max. Count Frequency	10kpps	
Count Edge Assignment	Available	Not Available
Count Register	16 bit Up/Down counter	
Counter Mode Switch	Depending on software settings	
Upper/Lower Limit Setting	Not available	
Preload/Prestrobe	Available	
Marker Input (Counter Value Clear)	None	IN3

Chapter 2 – Specifications

■ Pulse/PWM Output Specifications

DIO can be used as a PWM output or pulse output. The setup is performed by the LT Editor/C-Package.

Reference *LT Type H Series I/O Setting User Manual*

	Pulse Output	PWM Output
Output Points	4 Points	
Output Method	PLS0 to PLS3 (OUT 0 to OUT 3) defined by user	PWM0 to PWM3 (OUT 0 to OUT 3) defined by user
Load Voltage	DC24V	
Min. Load Current	1mA	
PWM Max. Output Frequency	—	2.5kHz
Pulse Array Maximum Output Frequency	5kHz (Total number of used channels)	—
Pulse Acceleration/Deceleration Speed	Available	—
ON Duty	50% +/-20% (at 5kHz) ^{*1}	10% to 90% (at 2.5kHz) ^{*2}

**1 The ON Duty error (20%) will be reduced if the Output frequency is low.*

**2 The ON Duty (effective range) will be widened if the Output frequency is low.*

2.3.2 Analog Input/Output Connector (Type H*-AD/ADP/ADT)

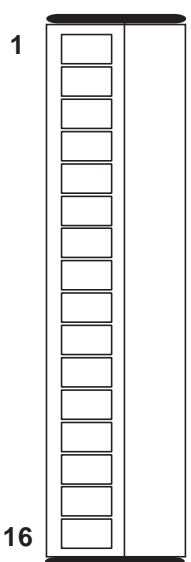
Pin Connection	Pin #	Signal Name	Condition
	1	24V	DIO Power 24V
	2	0V	DIO Power 0V
	3	FE	Terminal for Function Ground ^{*1}
	4	24V	Analog Power 24V ^{*2}
	5	0V	Analog Power 0V ^{*2}
	6	AO2I	Ch2 Analog Output (Current)
	7	AO2V	Ch2 Analog Output (Voltage)
	8	AOG	Analog Output Ground
	9	AO1I	Ch1 Analog Output (Current)
	10	AO1V	Ch1 Analog Output (Voltage)
	11	AIG2	Analog Input Ground
	12	AI2 JP	Ch2 Analog Input
	13	AI2 +	Ch2 Analog Input
	14	AIG1	Analog Input Ground
	15	AI1 JP	Ch1 Analog Input
	16	AI1 +	Ch1 Analog Input

**1 Ground this wire when noise or other problems occur during unit operation.*

**2 When using Pt100 or thermocouple, power is also supplied from No.4 pin and No.5 pin of the Analog Input/Output connector.*

Chapter 2 – Specifications

◆ Recommended Connector and Wire

BL3.5/16LH 16 pole screw-clamp type connector (Weidmuller)

Terminal block screw fastening torque : 0.2 to 0.4 N•m

Maximum wire size : 1.6 mm (AWG#14), Applicable to UL1015 or UL1007

Wire strip length : 4.5 to 6.0 mm [0.18 in. to 0.24 in.]

◆ Analog Input Specifications

No. of Input Channels		2 Channels
Input Range	At Voltage Setup	0 to 10 V (10.2375V max.) ^{*1}
	At Current Setup	0 to 20mA (20.475mA max.) ^{*1}
Resolution	At Voltage Setup	12 Bit (0-4000 (0-10V), 4095 max. (at 10.2375V))
	At Current Setup	12 Bit (0-4000(0-20mA), 4095 max. (at 20.475mA))
Accuracy		±1.0% of full scale (0-50°C)
Linearity		±3 LSB max.
Input Impedance	At Voltage Setup	100kΩ
	At Current Setup	250Ω
Input Delay Time		40ms/2 Channels
Absolute Max. Input Voltage		DC15V (Voltage)/ 60mA (Current)
Input Filter		Running average sampling time 2ms
Power Supply		DC24V External Power Supply
Insulation		Each channel – Internal: Insulation Between each channel: No insulation Each channel – Analog Power: Insulated
Input/Output Characteristics	Input Voltage	Input Current

*1 Switching the Voltage Input or Current Input can be set separately, for each channel.

Chapter 2 – Specifications

◆ Analog Input Circuit

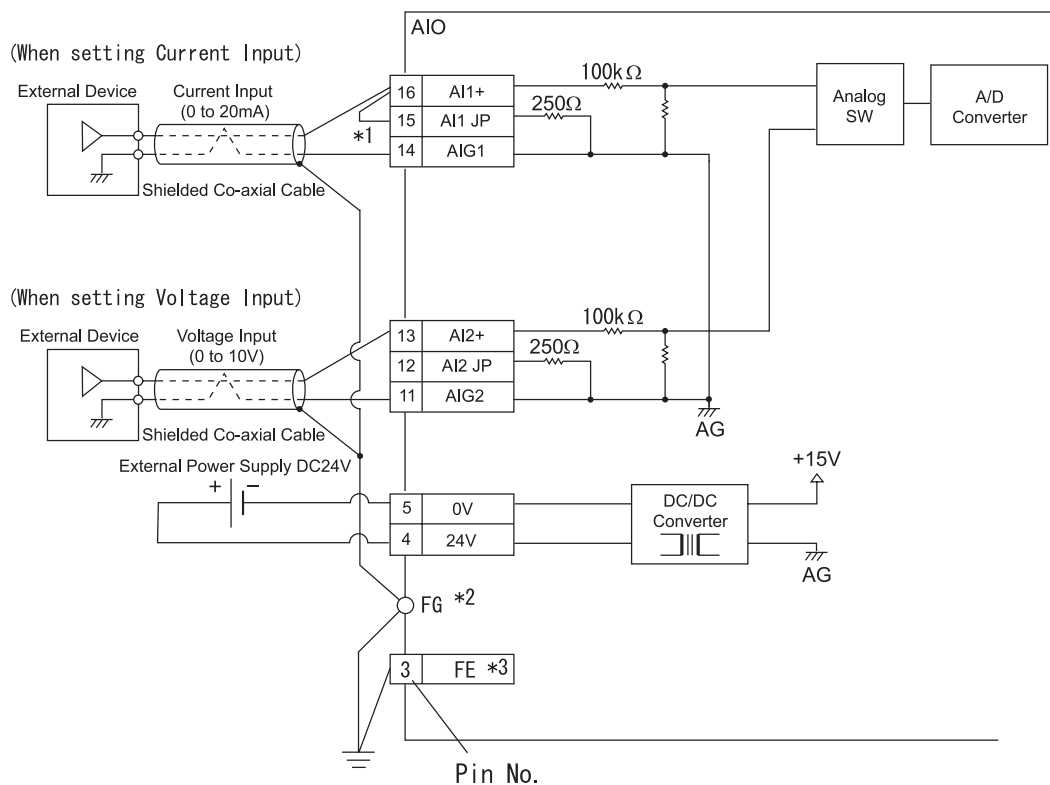

- *1 When the Current Input is selected, ground AI* and AI* JP.
- *2 Connect to the FG terminal in the main unit, or connect directly to frame ground (FG).
- *3 Ground this wire when noise or other problems occur during unit operation.



Use twisted pair wiring for Analog Input lines. The lines must be wired separately from high-frequency lines, such as high-voltage lines, high current lines, and inverters and power lines.

◆ Analog Output Specifications

Number of Output Channels		AD Type: 1 Channel
		ADP Type: 2 Channels
		ADT Type: 2 Channels
Output Range	At Voltage Setup	0 to 10 V (10.2375V max.)* ¹
	At Current Setup	0 to 20mA (20.475mA max.)* ¹
Resolution	At Voltage Setup	12 Bit (0-4000 (0-10V), 4095 max. (at 10.2375V))
	At Current Setup	12 Bit (0-4000 (0-20mA), 4095 max. (at 20.475mA))
Accuracy		±1.0% of full scale (0-50°C)
External Allowable Load	At Voltage Setup	10kΩ min.
	At Current Setup	500Ω max.
Power Supply		DC24V External Power Supply
Insulation		Each channel - Internal: Insulation Between each channel: No insulation Each Analog Power channel: Insulation
Input/Output Characteristics	Output Voltage	
	Output Current	

*1 Switching the Voltage Input or Current Input can be set separately, in each channel.

Chapter 2 – Specifications

◆ Analog Output Circuit

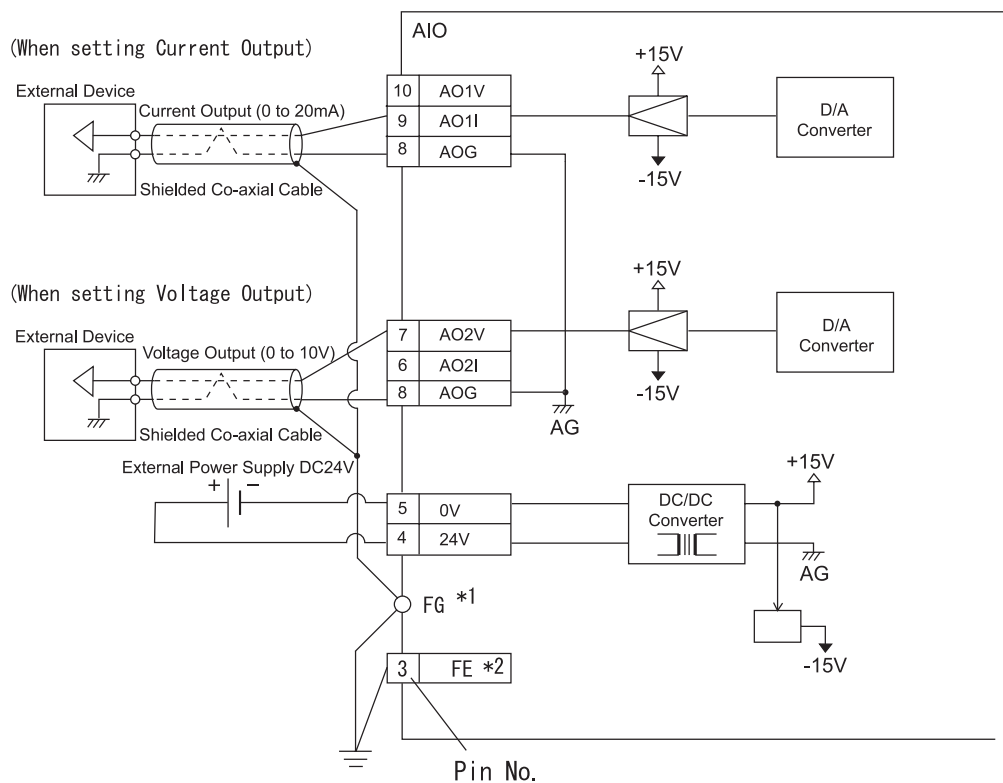

*1 Connect to the FG terminal in the main unit, or connect directly to frame ground (FG).

*2 Ground this wire when noise or other problems occur during unit operation.

2.3.3 Temperature Input Connector (Type H*-ADP/ADT)

■ Pt 100 Input Specifications (Type H*-ADP)

◆ Pt100 Input

Pin Connection	Pin #	Terminal Name	Function
	1	PT1 A	Pt100 Input Ch1
	2	PT1 B	Pt100 Input Ch1
	3	PT1 B	Pt100 Input Ch1
	4	PT2 A	Pt100 Input Ch2
	5	PT2 B	Pt100 Input Ch2
	6	PT2 B	Pt100 Input Ch2

◆ Recommended Connector and Wire

BL3.5/6LH 6 pole screw-clamp type connector (Weidmuller)

Terminal block screw fastening torque : 0.2 to 0.4 N•m

Maximum wire size : 1.6 mm (AWG#14), Applicable to UL1015 or UL1007

Wire strip length : 4.5 to 6.0 mm [0.18 in. to 0.24 in.]

◆ Pt100 Input Specifications

Subjected Resistance Temperature Sensor		Pt100	
Measurable Temperature Range		Celsius: -50 to 400°C	Fahrenheit: -58 to 752 F
Accuracy		±1.0% (Full Scale)	
No. of Input Channels		2 Channels	
Temp. Conversion Data		Celsius: -500 to 4000	Fahrenheit: -580 to 7520
External Wiring Length		Each Channel: 50m max.	
Conversion Time		Approx. 85ms x filter frequency (1 to 64) ^{*1}	
Insulation	Channel – Channel	No Insulation	
	Input Section – Internal Section	Photocoupler Insulation	
Insulation Resistance		Power for analog (DC24V) primary and secondary AC500V	
Additional Function		Linearise pulses	
Error Detection		Temperature conversion data when exceeding measured temperature range Exceeding the upper limit: 32767 Exceeding the lower limit: -32768	
Disconnect Processing		Temperature conversion data is 32767	
Wiring		3-wire method	
Input Output Characteristics	Celsius (°C)		Fahrenheit (F)

**1 Except for delay time, depending of the LT unit's scan time.*

◆ Thermocouple Input Specifications

Item		Specification
Subjected Resistance Temperature Sensor		Thermocouple J Type or K Type
Measurable Temperature Range		J Type Celsius: -100 to +700°C, Fahrenheit: -148 to +1292 F K Type Celsius: -100 to +1200°C, Fahrenheit: -148 to +2192 F
Accuracy		±1.0% (Full Scale)
Number of Input Channels		3 Channels
Temperature Conversion Data		J Type Celsius: -1000 to +7000, Fahrenheit: -1480 to +12920 K Type Celsius: -1000 to +12000, Fahrenheit: -1480 to +21920
External Wiring Length		Each Channel: 50m max. (by compensating conductors)
Conversion Time		Approx. 170ms x filter frequency (1 to 64) ^{*1}
Insulation	Channel – Channel	No Insulation
	Input Part – Internal Part	Photocoupler Insulation
Insulation Resistance		Power for analog (DC24V) primary and secondary (AC500V)
Additional Function		Linearize pulses
Error Detection		Temperature conversion data when exceeding measured temperature range Exceeding the upper limit: 32767 Exceeding the lower limit: -32768
Disconnect Processing		Temperature conversion data is 32767
Input Output Characteristics		Celsius (°C)
		Fahrenheit (F)

*1 Except for delay time, depending of the LT unit's scan time.

Chapter 2 – Specifications

◆ Thermocouple Input Circuit

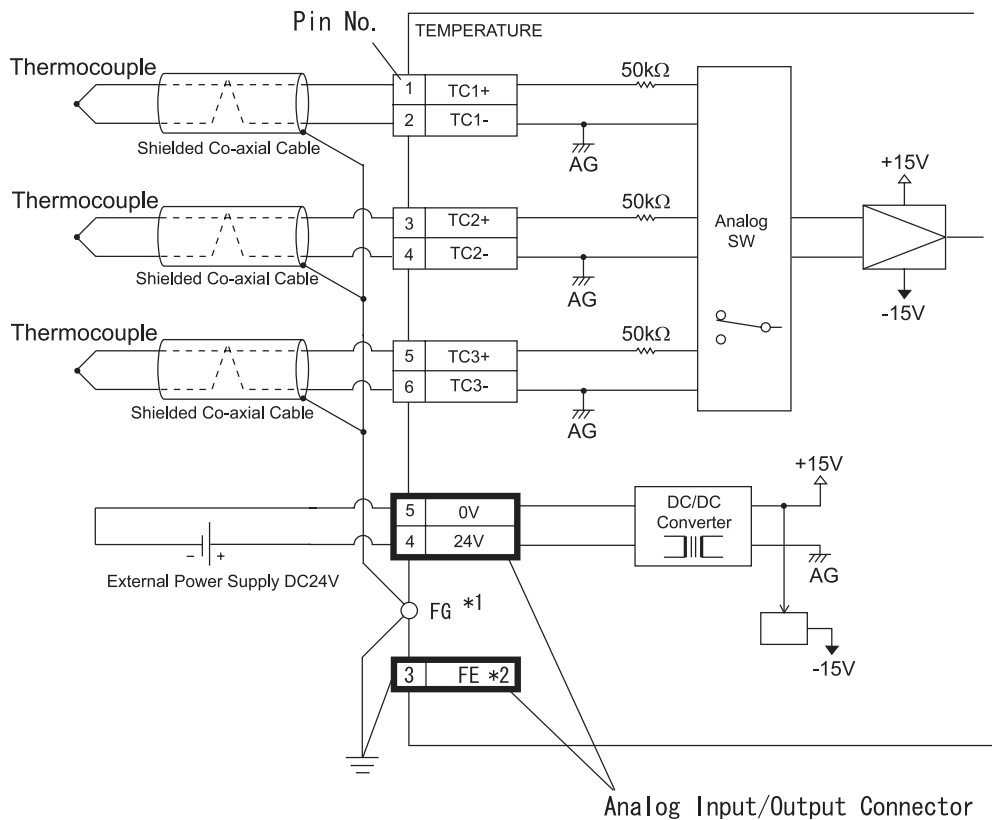

- *1 Connect to the FG terminal on the main unit, or directly to the frame ground (FG).
 *2 Ground this wire when noise or other problems occur during unit operation.



- Thermocouple lines must be wired separately from high-frequency lines such as high-voltage lines, high current lines, and inverters and power lines.
- Be sure to use the specified (J Type, K Type) compensating conductors when the thermocouple input is extended. Be sure to keep all input lines as short as possible.
- The compensating conductor is polarized (+ and -). Be sure to connect it correctly; otherwise, accurate temperatures cannot be measured.
- Since each thermocouple (between the channels) is not insulated, be sure to use insulated (non-grounding) type thermocouples.
- When wiring external power to the Analog Input connector, connect 24V to No. 4 pin, and 0V to No. 5 pin.

2.4 Part Names and Functions

A: Display Panel

The LT monitor screen displays user-created screens and corresponding external device data.

B: Touch Panel

Enables the user to perform screen change operations or enter data.

C: Status LED

Indicates the LT unit's current condition.

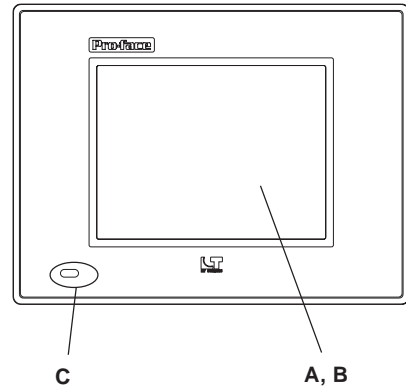

Color	Indicator	Operation Mode ^{*1}	Controller Operation Mode ^{*2}
Green	ON	OFFLINE	STOP
	ON	RUN	RUN
	Flashing	RUN	STOP
Green and Red	Both ON	RUN	Backlight Burnout detected
Red	ON	RUN	Major Alarm (Stop)

*1 Operation Mode refers to a display and Touch Key feature.

*2 Controller Operation Mode refers to the feature that executes a logic program.

D: Input/Output LED

Displays the status of DIN/DOUT.

E: Run/Stop Switch

(When running, LED is ON)

Run: Executes logic program

Stop: Stops logic program

F: ReadyLED

Indicates the LT unit's current condition.

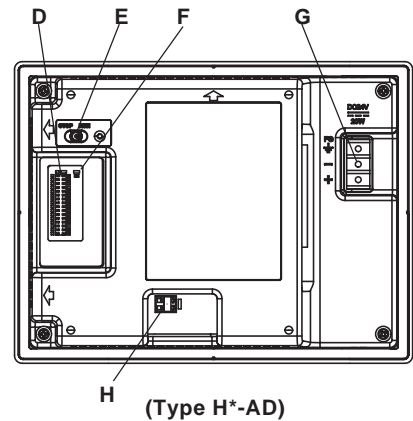

Condition	LED
I/O board error	OFF
I/O board is normal	ON

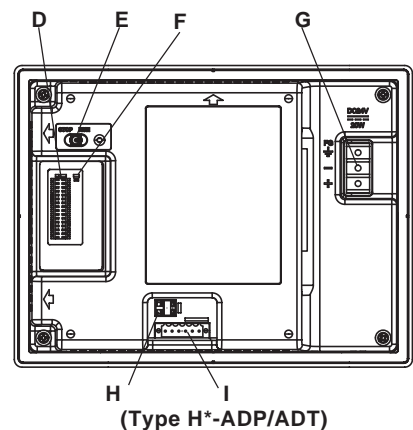

Chapter 2 – Specifications

G: Power Input Terminal Block

Connects Power Cord or Frame Ground (FG).

H: Alarm Output Circuit

When a major error or a Watchdog Timer error occurs, it turns OFF (releases) the contact.

Reference 2.2.5 – “*External Interface – Alarm Output*”

I: Temperature Input Interface

Connects Pt100 sensor or thermocouple sensor with the screw-clamp type connector.

J: DIO Input/Output Connector

Connects external Input/Output units with the spring-clamp type connector.

K: Analog Connector

Connects control units such as sensors with the screw-clamp type connector.

L: Tool Connector

Connects Data Transfer Cable.

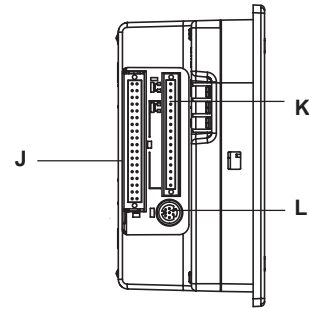

2.5 Dimensions

2.5.1 LT External Dimensions

Unit: mm [in.]

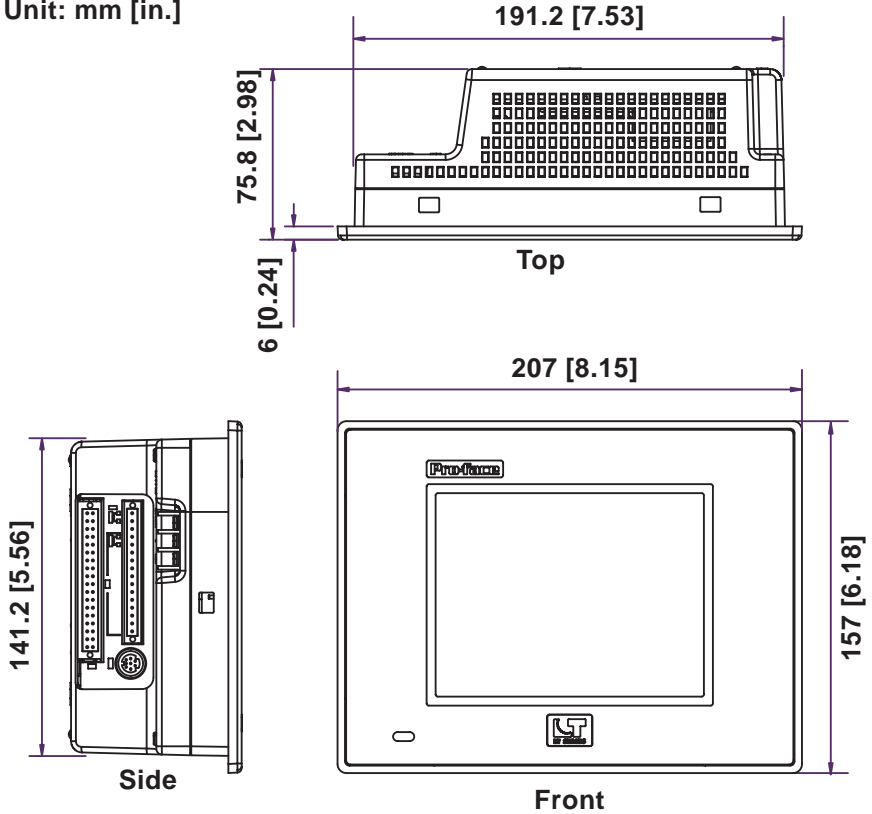

The following drawing shows the LT unit with installation fasteners.

Unit: mm [in.]

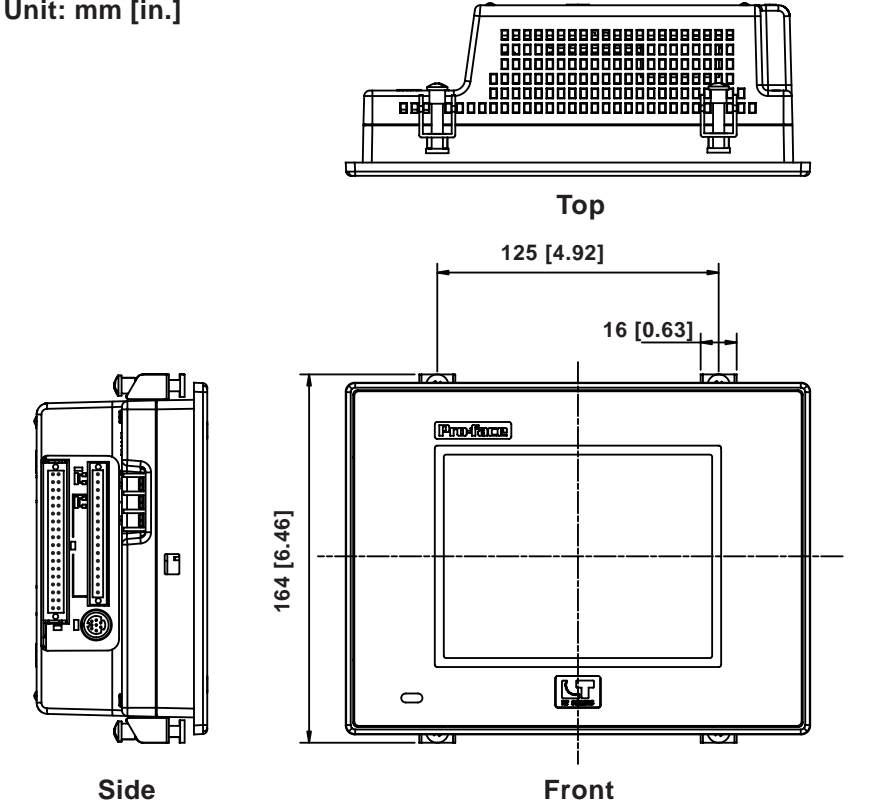

Chapter 2 – Specifications

2.5.2 Installation Fasteners

Unit: mm [in.]

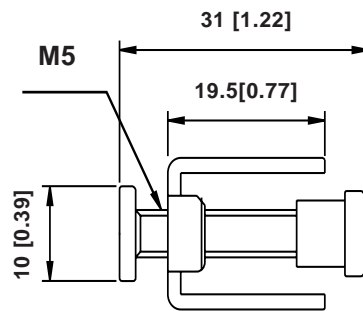
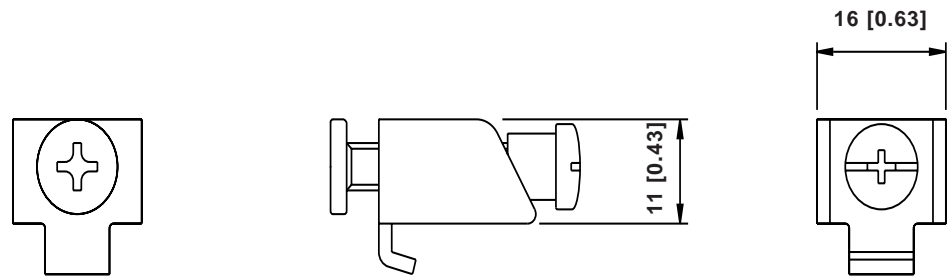

2.5.3 Panel Cut Dimensions

Unit: mm [in.]

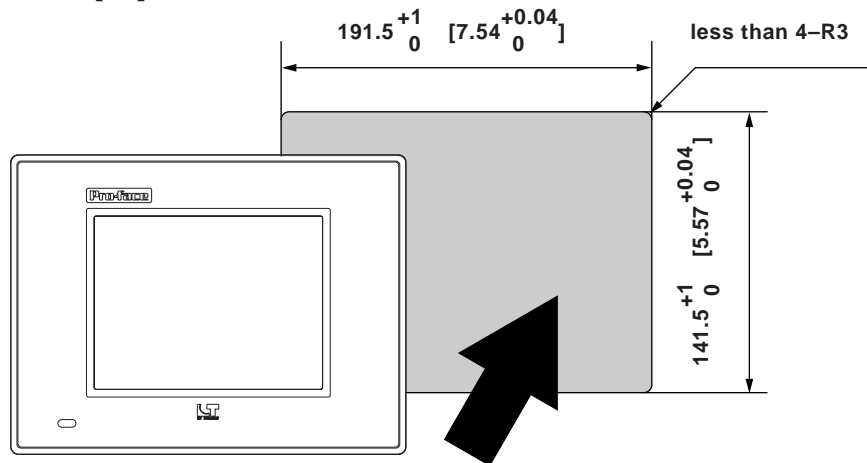

Chapter

3 Installation and Wiring

1. Installation
2. Wiring Cautions
3. Tool Connector

3.1 Installation

Follow the steps in this section to install the LT.

3.1.1 Installation Procedures

■ Attaching the Installation Gasket

Pro-face strongly recommends that you use the installation gasket provided, since it absorbs vibration as well as repelling water.

Place the LT face down on a level surface and check that the LT unit's installation gasket is securely fitted into the groove that runs around the perimeter of the panel's frame.

Reference 8.1.2 – “Installation Gasket Check/Replacement.”

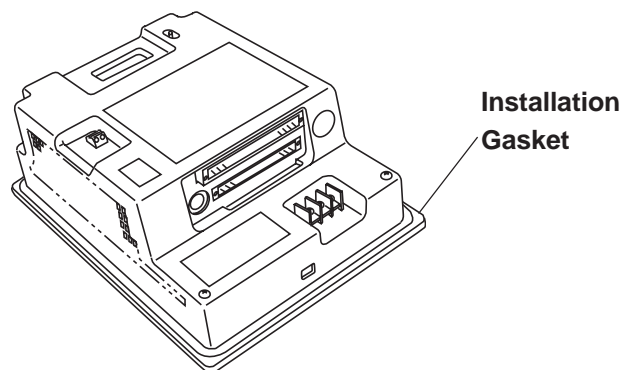

Before installing the LT into a cabinet or panel, check that the Installation gasket is securely attached to the unit.

Chapter 3 – Installation and Wiring

■ Creating a Panel Cut

Create an opening with the correct dimensions to install the LT.

Reference 2.5.3 – “LT Panel Cut Dimensions.”

The installation gasket, installation fasteners, and attachment screws are all required when installing the LT.

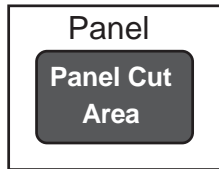

Note:

Make sure that the installation panel or cabinet's surface is flat, in good condition, and has no jagged edges. Metal reinforcement strips can also be attached to the inside of the panel, near the Panel Cut, to increase the panel's strength.



Panel thickness should be between 1.6 and 5.0 mm (0.06 to 0.02 in.), and should be based on the strength required to mount the LT to the panel.

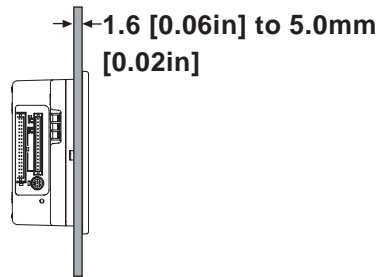

For easier maintenance and operation, and improved ventilation, install the LT at least 100 mm (3.94 in.) away from adjacent structures and other equipment.

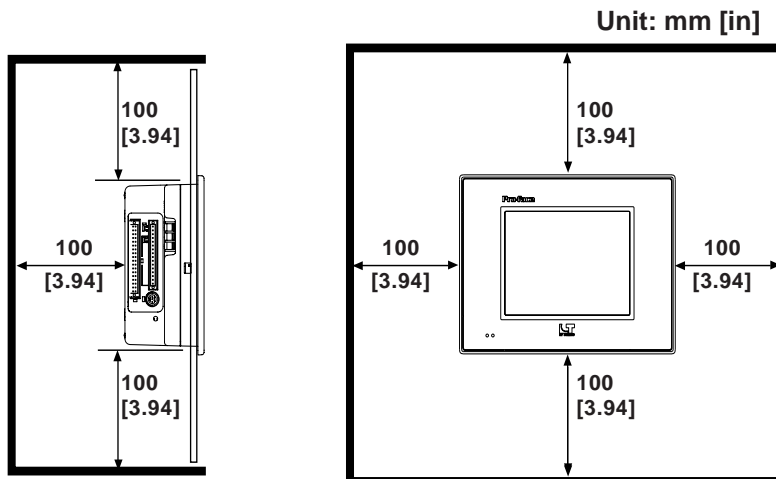



- To prevent accidents, be sure the Operating Temperature is from 0°C to 50°C, and the Ambient Humidity is from 10%RH to 90%RH. (Wet bulb temperature of 39°C max.)
- “Ambient operation temperature,” when referring to the installation of the LT in a cabinet or other enclosure, indicates the internal temperature of the cabinet or enclosure.

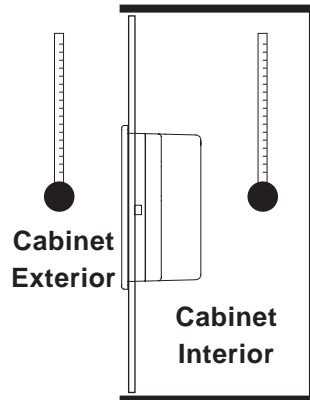

- Make sure that heat from surrounding equipment does not cause the LT to exceed its standard operating temperature.
- When installing the LT in an angled panel (vertical type), the panel's face should NOT incline more than 30°.

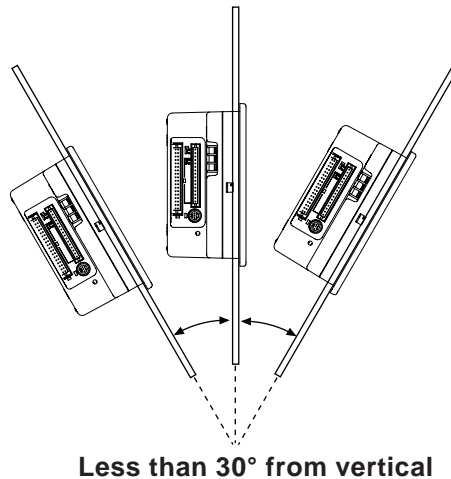

When installing the LT in an angled panel (vertical type), and the panel's face inclines at an angle greater than 30°, the ambient temperature must NOT exceed 40° C. You may need to use forced air cooling to ensure the ambient operating temperature is lower than 40° C.

Chapter 3 – Installation and Wiring



When installing the LT vertically, position the unit so that the arrows on the back of the LT point upwards.

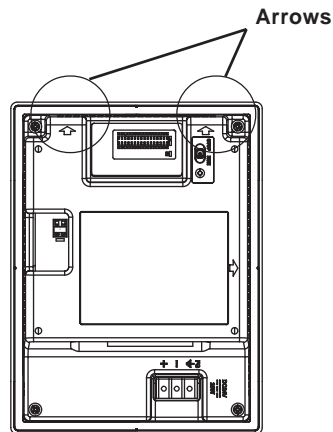

■ Installing the LT

1. Insert the LT into the panel cutout with the front of the panel facing outwards.

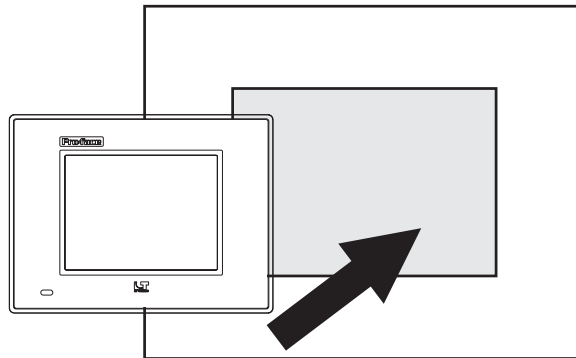

2. Insert the installation fasteners into the LT unit's top and bottom face insertion slots — two slots each. If required, the two side face insertion slots (right and left) can also be used.

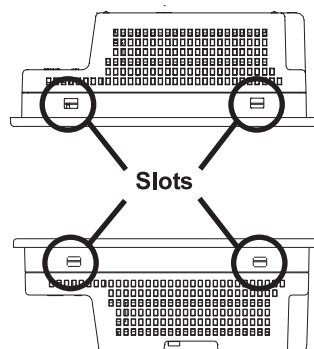

Chapter 3 – Installation and Wiring

3. Insert each of the fasteners as follows.

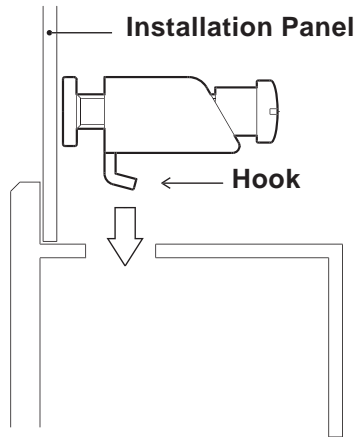

4. Be sure to pull the fastener back until it is flush with the rear of the attachment hole:

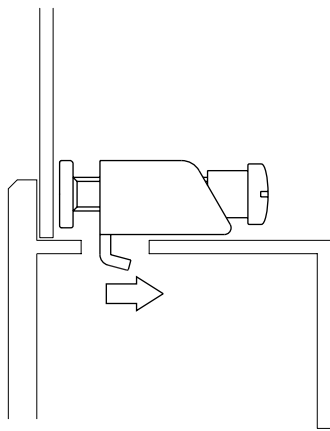

5. Use a Phillips screwdriver to tighten each fastener screw and secure the LT in place.

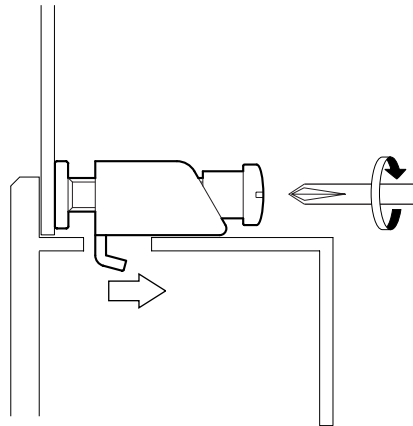

A torque of only 0.5 to 0.6 N•m is sufficient to tighten these screws. Excessive force may damage the LT unit.



Depending on the condition of the panel, increasing the number of installation fasteners will raise the level of water resistance.

Chapter 3 – Installation and Wiring

3.1.2 DIO Connector Installation

Use the following procedures to install the DIO connector. The DIO connector is packaged pre-installed on the main unit.

■ Installing the DIO Connector

1. Remove the DIO connector installed on the main unit by pressing down on the levers on both sides of the connector.
2. Insert a screwdriver into the hole under the desired pin and insert the wire completely into the hole. Remove the screwdriver clamp the wire.

Reference ■ *DIO Connector*
(see below)

3. Replace the DIO connector.

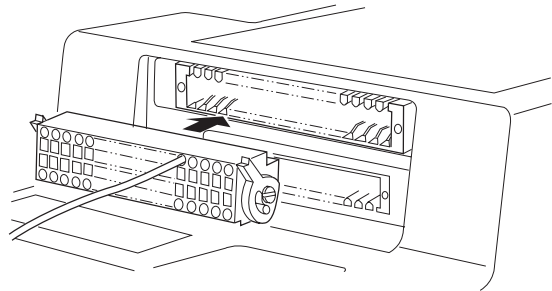
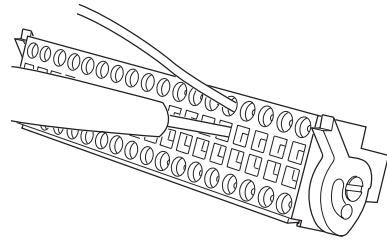
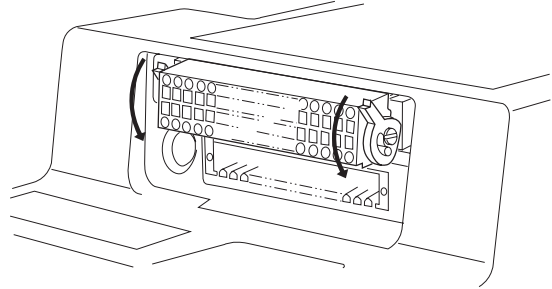

■ Wiring the DIO Connector

The user should prepare a standard flat-bladed screwdriver.

- Recommended screwdriver: SDI (Product Number: 900837) [Weidmuller (Japan)]
 - Thickness: 0.4mm [0.02 in.]
 - Tip width: 2.5mm [0.10 in.]
 - Length: 80mm [3.15 in.] (from tip to handle.)
 - Tip shape: Equivalent to DIN526A/DN EN60900 safety standards



Screwdriver Tip

Prior to wiring, be sure to check all pin assignments.

Reference 2.3.1 – “DIO Connector”

Chapter 3 – Installation and Wiring

Procedures for Wiring to the Connector

The connector is a spring clamp type. Wire the connector, using the following procedures.

1. Insert the slot screwdriver deep into the connector's rectangular slot. The round wire insertion hole located beside the tool slot will open.
2. Insert the wire through the round wire insertion hole while the slot screwdriver is inserted.
3. Remove the slot screwdriver from the rectangular tool slot. The round wire's insertion hole will close, and the wire will be held.

To remove the wire from the round wire insertion hole, be sure to insert the slot screwdriver deep into the corresponding rectangular tool slot.

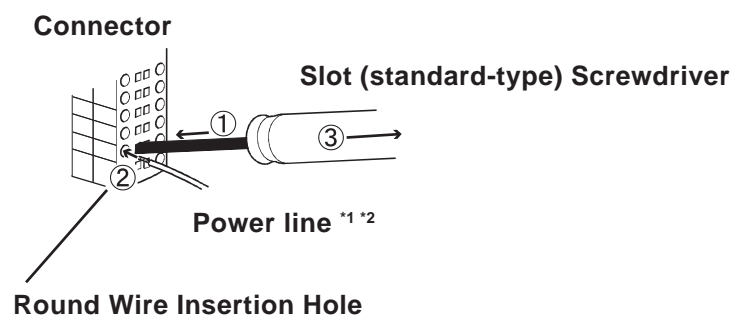

*1 Use stranded wire that is 0.3 to 1.0mm (AWG22-18). UL1015 or UL1007 types of wires are recommended.

*2 Recommended strip length is 6.5mm [0.26 in.] to 8.0mm [0.31 in.].



- Be sure to keep the strip length of the wire within the range recommended above. If the strip is too long, the conductor may extend out of the insertion hole and cause an electrical shock or short circuit with other wires.
- Do not solder the wire (stranded wire). Doing so may result in a bad electrical contact.
- Be sure to insert all wire ends (stranded wire) in the round wire insertion holes to prevent a malfunction or short circuit with other electrical wires.

*3 Do NOT twist the screwdriver in the connector's rectangular slot. Doing so may cause a malfunction.

Chapter 3 – Installation and Wiring

3.1.3 Analog Input/Output Connector and Temperature Input Connector Installation

Use the following procedures to install the analog input/output connector and the temperature input connector. The following illustrations are examples of the analog input/output connector, but the same installation procedures are used for the temperature input connector.

■ Installing the Connectors

1. Remove the analog input/output connector installed on the main unit by lifting the levers on both sides of the connector.
2. Loosen the corresponding pins and insert the wire.*¹ Insert the wire fully, and tighten the screws.
3. Replace the analog input/output connector in its original position.
To install the temperature connector, tighten the screws on the sides.*²

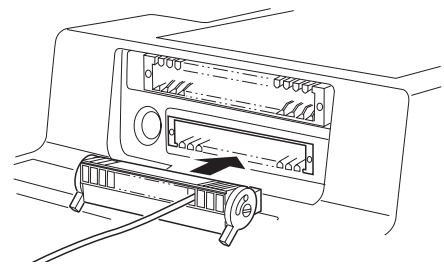
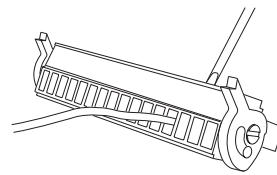
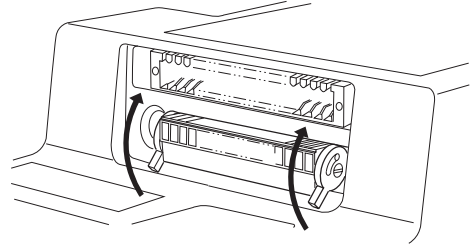

*¹ If wire ends are not carefully twisted, strands from adjacent wires may come in contact with an electrode and cause a short circuit.

The recommended wire size is 1.6 mm max. (AWG14 MAX); UL1015 or UL1007 types are recommended.

The recommended strip length is 4.5mm [0.18 in.] to 6.0mm [0.24 in.].



- The strip length of the wire should be kept within the range recommended above. If the strip is too long, the conductor may extend out from the insertion hole and may cause an electrical shock or a short circuit with other wires.
- Do not solder the wire (stranded wire). Doing so may result in a bad electrical contact.
- Insert all wire ends (stranded wires) completely into the round insertion holes to prevent a malfunction or short circuit with other wires.

*¹ Do not twist the slot screwdriver in the connector's rectangular tool slot. Doing so may cause a malfunction.

*² To tighten the terminal screws, use a small screwdriver (thickness of 0.4mm [0.02 in.] and tip width of 2.5mm [0.10 in.]).

A torque of only 0.2 to 0.4 N•m is sufficient to tighten the terminal block screws.

3.2 Wiring Cautions

3.2.1 Connecting the Power Cord



WARNING

- To avoid an electrical shock, be sure the power cord is unplugged from the power outlet when connecting the power terminals to the LT unit.
- The LT requires a DC 24V power supply. If the power supply does not match the model, both the power supply and LT unit will be damaged.
- Reattach the LT Terminal Strip's clear plastic cover after the wiring is completed. If the cover is not installed, it may cause an electrical shock.
- Since the LT is not equipped with the power switch, be sure to connect a breaker type power switch to the LT's power code.



- To prevent the Ring Terminals*1 from short-circuiting when the terminal block attachment screws are loosened, use sleeve-type Ring Terminals.
- When the FG terminal is connected, be sure that the wire is grounded. Not grounding the LT unit will result in excessive noise. Use your country's applicable standard for grounding.

Reference 3.2.2 – “Grounding”



- Whenever possible, use thick wires (max. 2mm²) for power terminals, and twist the exposed wire ends when connecting the Ring Terminals.
- Use the following size crimp-on type Ring Terminals:

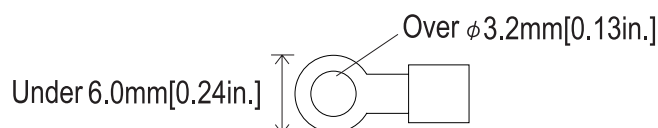

*1 Recommended Ring Terminal: V2-MS3 (JST)

Chapter 3 – Installation and Wiring

■ Connecting the Power Supply Terminals

1. Make sure that the LT unit's power cord is not plugged in to the power supply.
2. Remove the Terminal Strip's clear plastic cover.
3. Remove the screws from the three (3) middle terminals, position the Ring Terminals (see below), and reattach the screws. Check each wire to make sure the connections are correct, and use only 0.5 to 0.6 N•m of force.

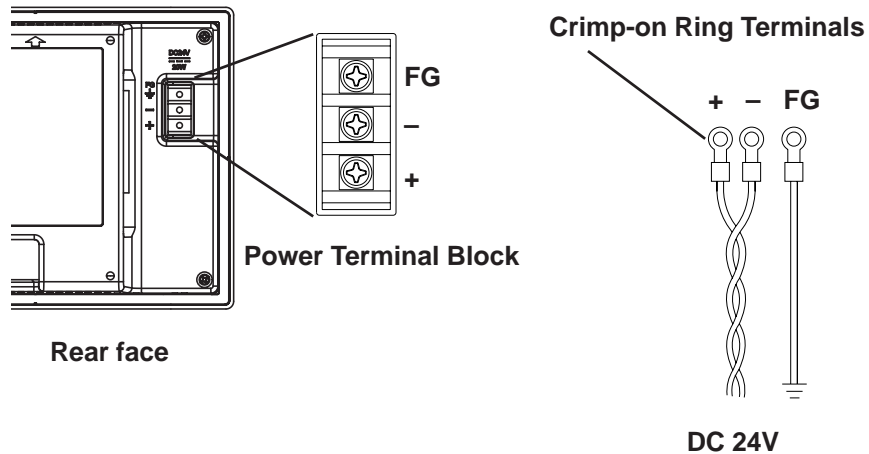

4. Reattach the Terminal Strip's clear plastic cover.

3.2.2 Grounding



CAUTION

Do not use common grounding, since it can lead to an accident or machine breakdown.

Connect the FG terminal found on the back of the LT to an exclusive ground (diagram A).

(A) Exclusive Grounding (BEST)

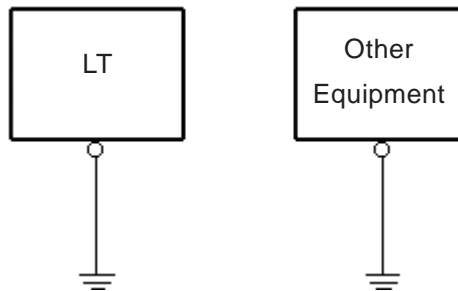

- Make sure that the grounding resistance is less than 100Ω.
- FG and SG terminals are internally connected in the LT. When connecting to another device, be sure to not create an SG shorting loop in your system.
- The grounding wire should have a cross-sectional area of at least 2mm². Create the grounding point as close to the LT unit as possible, and keep the wires as short as possible. Replace all thin wires with thicker wires, and place them in a duct.

If exclusive grounding is not possible, use a common connection point (dia. B).

(B) Common Grounding (OK)

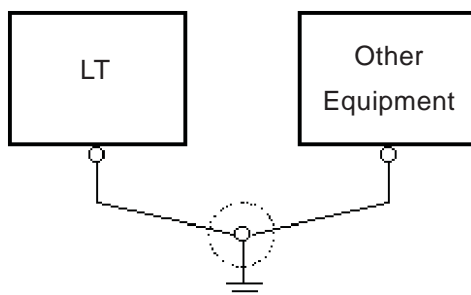

(C) Common Grounding (Not OK)

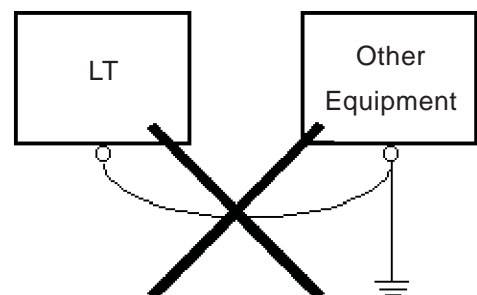

Note: If the equipment does not function properly when grounded, disconnect the ground wire from the FG terminal.

Chapter 3 – Installation and Wiring

3.2.3 I/O Signal Line Cautions

To help prevent noise and interference problems, separate all control, analog input/output (temperature input) cable communication and power lines by placing them in separate ducts.

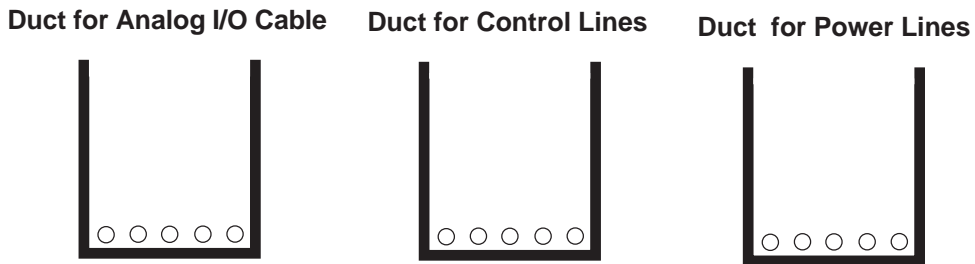

If different wires must be placed in the same duct, separate them with an earthed/grounded divider.

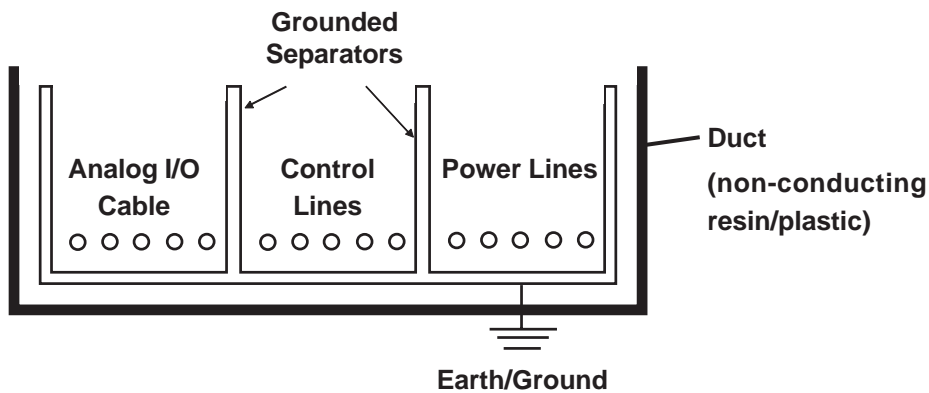

Note:

If the lines cannot be separated, use shielded lines and create a ground from the shield line.



Important

- Use noise-reducing external wiring methods to increase overall system reliability.
- To prevent power surges or noise interference, use ducts to separate all DC I/O or current circuit wires from communication cables.
- To prevent malfunctions due to noise, analog I/O (temperature Input) cable must be wired separately from high-frequency lines and power lines such as high-voltage lines, high-current lines, and inverters.

3.2.4 Installation Cautions

A problem in the external power supply or an LT unit failure can lead to operation failures.

Since these types of failures can affect the entire system, as a preventive measure, be sure to set up a protection circuit (such as an Emergency Stop, Protection Network, Interlock, or System Design Circuit) in areas where potential failures may occur.

Examples of protection circuits that ensure the system's reliability include the following:

■ Failsafe Electrical Circuits

When designing failsafe circuits, be aware of possible malfunctions resulting from differences in the startup times of the control device connected to LT output unit (especially the DC power supply), the LT unit's system, and the program.

For example, connect an electrical voltage relay coil to the LT output unit power supply circuit and to any connected control devices' power circuit, then connect their contacts to the LT input unit. Design the circuit so that it checks for an ON signal from the electrical voltage relay using a logic program, then executes the ladder program of the control device connected to the LT output unit.

■ Input Voltage

The power supply must be DC 24V (between DC 20.4V and DC 28.8V).

■ Power Interruptions

When a power supply interruption is 10 ms or longer, the LT unit's power will also stop. Also, when a power interruption occurs, operation will stop even while a command is being issued.

For example, if the power is cut while an FMOV command is sending data in 100-word units, command execution will stop.

When designing the program, allow for the possibility of a power interruption.

Chapter 3 – Installation and Wiring

■ Emergency Stop Circuits

Do NOT send an Emergency Stop signal to the LT, and do NOT use the LT unit's internal software to process an Emergency Stop signal.

As shown below, be sure to create the Emergency Stop circuit outside the LT.

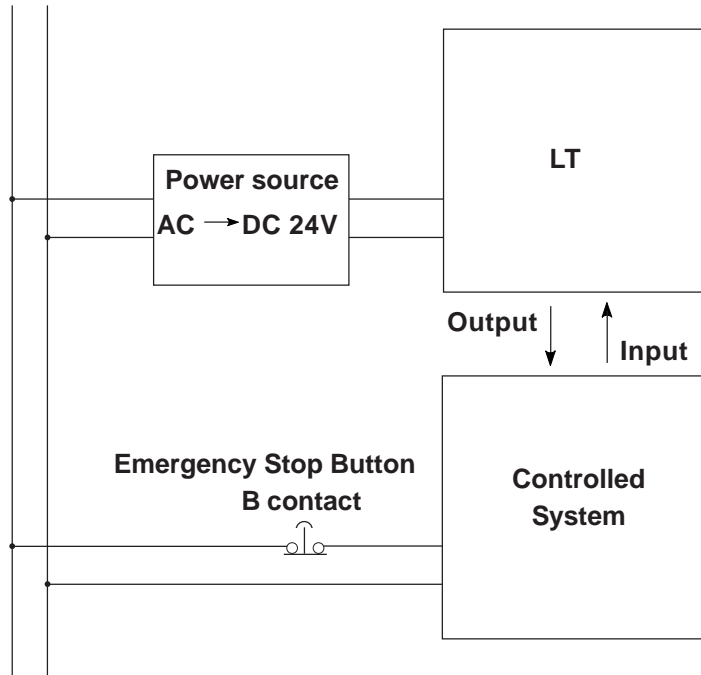

■ Interlock Circuit 1

Create an interlock circuit outside the LT (below), to control a motor's forward/reverse rotation circuit using an LT or external device connection.

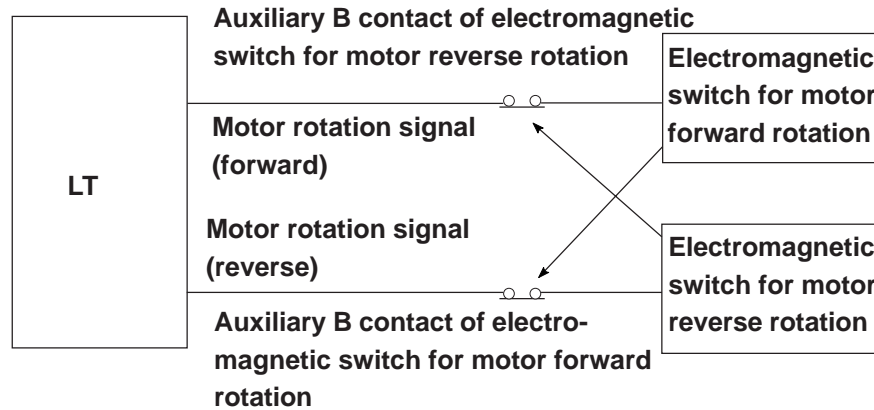

Note: After the LT or external device runs the program, the timing of the ON/OFF signals to the output device is carried out simultaneously.

For example, an electromagnetic switch for forward and reverse motor rotation could be turned ON and OFF at the same time. Therefore, when the main contact for the power circuits of both the forward and the reverse motor rotation are turned ON and OFF at the same time, there is a possibility that an R Phase and a T Phase short circuit will occur. Please use the above interlock, or a mechanical interlock equipped with an electromagnetic switch, when designing a forward/reverse rotation circuit.

■ Interlock Circuit 2

If there is a possibility that an LT failure could cause an accident, use an external hardware device to include a failsafe element in the design of the interlock circuit. For example, if the system first needs to stop the Travel Motor whenever the Unit Travel Limit Switch is activated, include the Unit Travel Limit Switch in the LT input. The following circuit uses a hardware method to ensure that the Travel Motor is stopped.

This applies to hardware; do NOT rely on software to process the interlock signals.

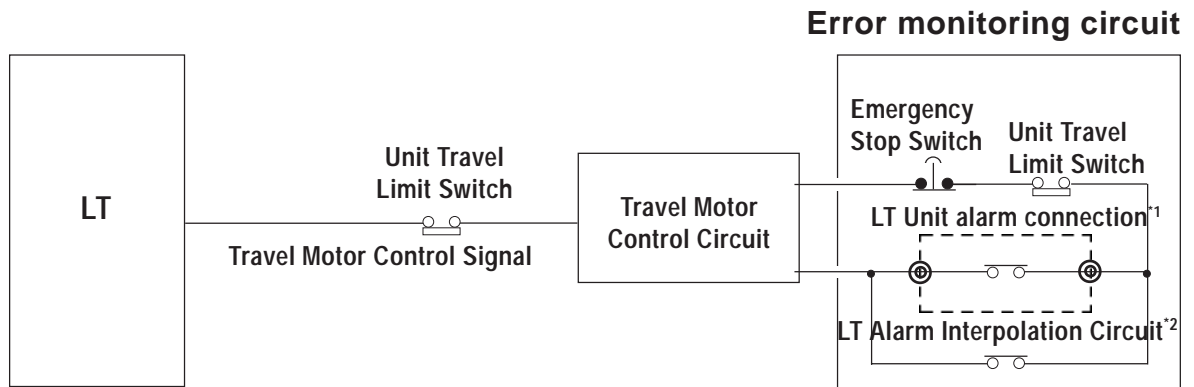

Chapter 3 – Installation and Wiring

3.2.5 Connection to Pulse Motor Amplifier (CW/CCW System)

(Examples)

The following examples illustrate how to connect the LT unit and the pulse motor amplifier (driver) of the sink (NPN) transistor output.



Note:

The pulse motor amplifier is described as a DC24V CW and CCW system. However, withstand voltage and operating power of the photocoupler where pulse signals are received may differ, depending on the manufacturer.

Reference Please contact the manufacturer of the amplifier you are using.

■ LT Type H1 (Output Sink Type)

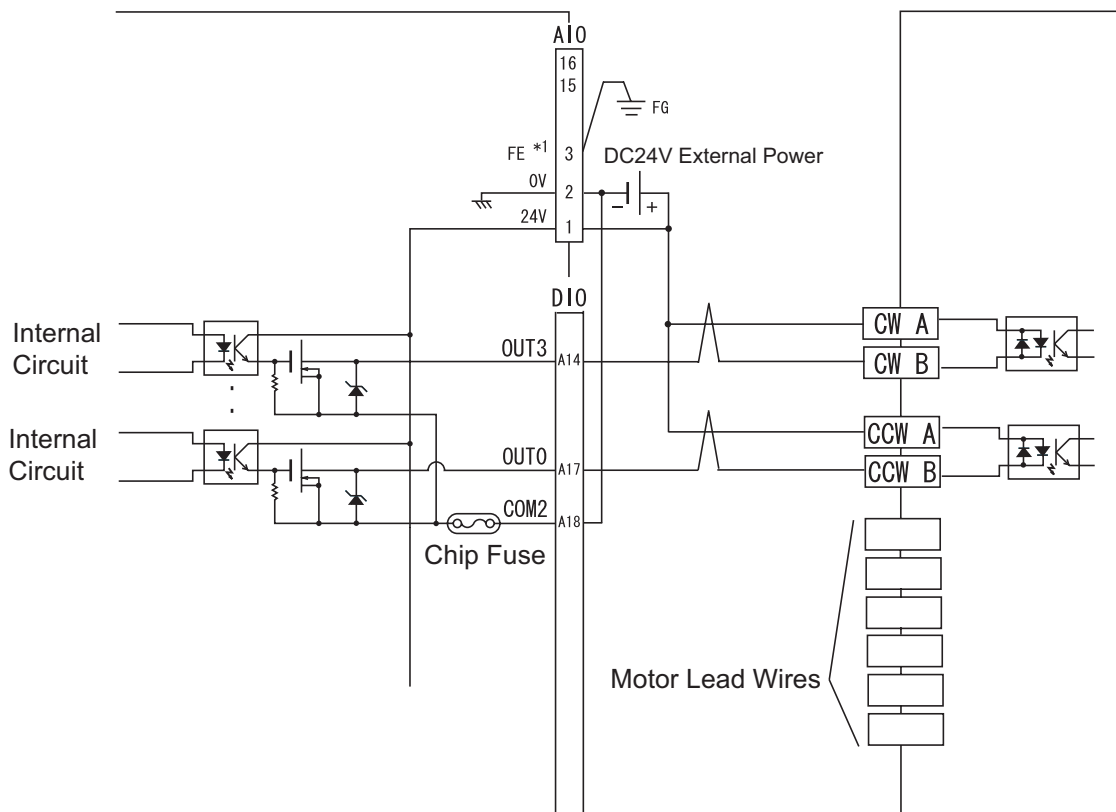

*1 Ground this wire when noise or other problems occur during unit operation.



Note:

Pin numbers A14 to A17 are the pulse output terminals in the LT unit.

Reference LT Type H I/O Setting User Manual (sold separately)

Chapter 3 – Installation and Wiring

■ LT Type H2 (Output Source Type)

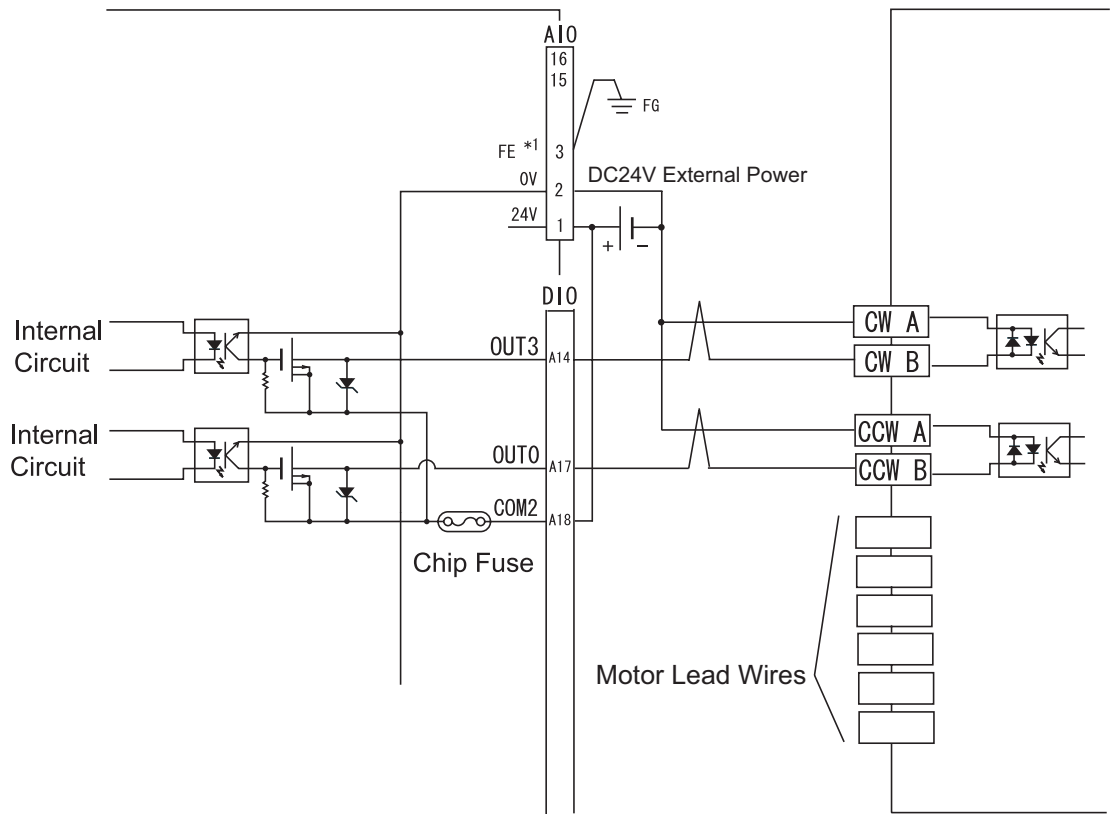

*1 Ground this wire when noise or other problems occur during unit operation.



Pin numbers A14 to A17 are the pulse output terminals in the LT unit.

Reference *LT Type H I/O Setting User Manual* (sold separately)

Chapter 3 – Installation and Wiring

3.2.6 Connection to Pulse Motor Amplifier (Clock Up/Down System)

(Example)

The following examples illustrate how to connect the LT unit and the pulse motor amplifier (driver) of the sink (NPN) transistor output.



Note:

The pulse motor amplifier is described as a DC24V clock up/down system. However, withstand voltage and operating power of the photocoupler where pulse signals are received may differ, depending on the manufacturer.

Reference Please contact the manufacturer of the amplifier you are using.

■ LT Type H1 (Output Sink Type)

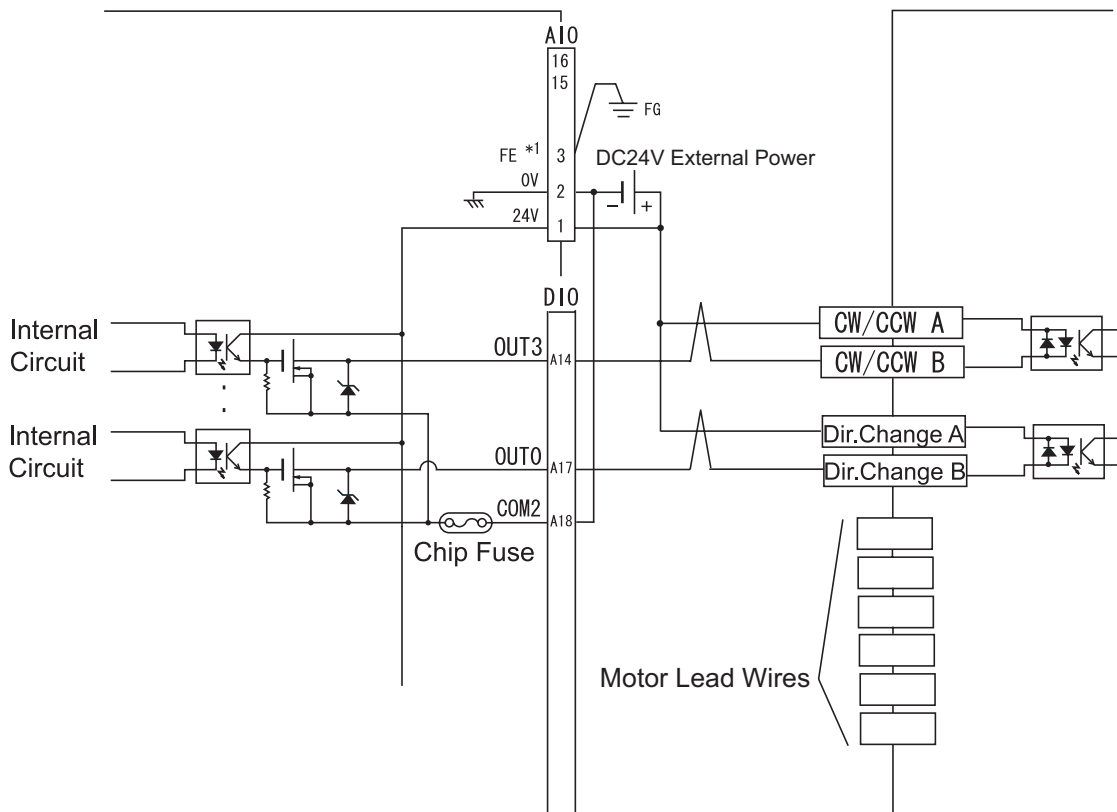

*1 Ground this wire when noise or other problems occur during unit operation.



Note:

- Pin numbers A14 to A17 are the pulse output terminals in the LT unit.

Reference *LT Type H I/O Setting User Manual*
(sold separately)

- To output to the direction switch, you can connect terminals other than high-speed terminals (pin numbers A14 to A17).

■ LT Type H2 (Output Source Type)

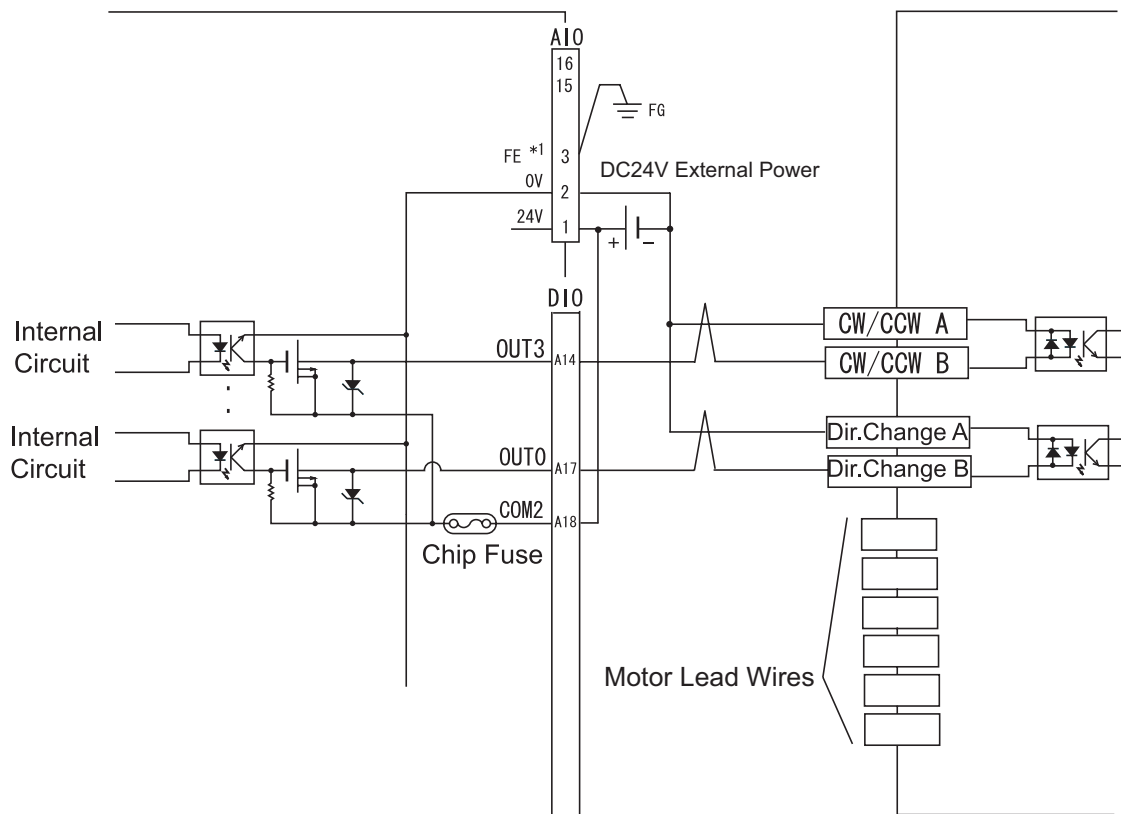

*1 Ground this wire when noise or other problems occur during unit operation.



Note:

- Pin numbers A14 to A17 are the pulse output terminals in the LT unit.

Reference *LT Type H I/O Setting User Manual*
(sold separately)

- To output to the direction switch, you can connect terminals other than high-speed terminals (pin numbers A14 to A17).

Chapter 3 – Installation and Wiring

3.2.7 Connection Examples to Rotary Encoder

The following examples illustrate how to connect the LT unit and the rotary encoder of the Sink (NPN Type) transistor output.

■ Sink Type Rotary Encoder

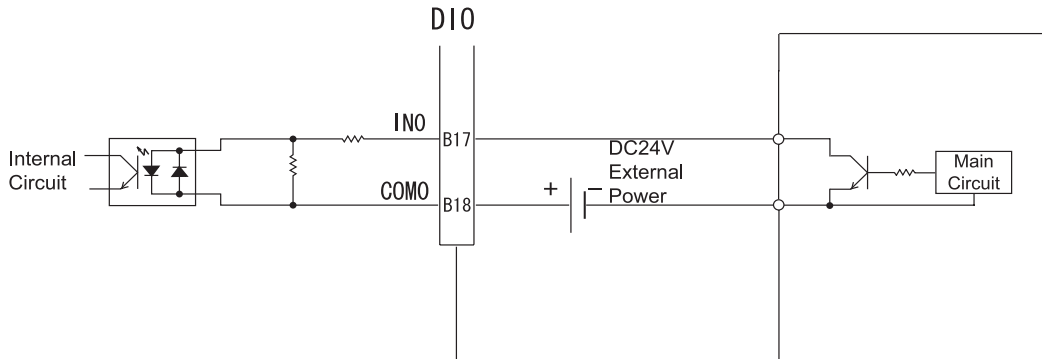

Note: Pin Numbers B11, B13, B15, and B17 can be used as the counter input terminals in the LT unit.

Reference *LT Type H I/O Setting User Manual (sold separately).*

■ Source Type Rotary Encoder

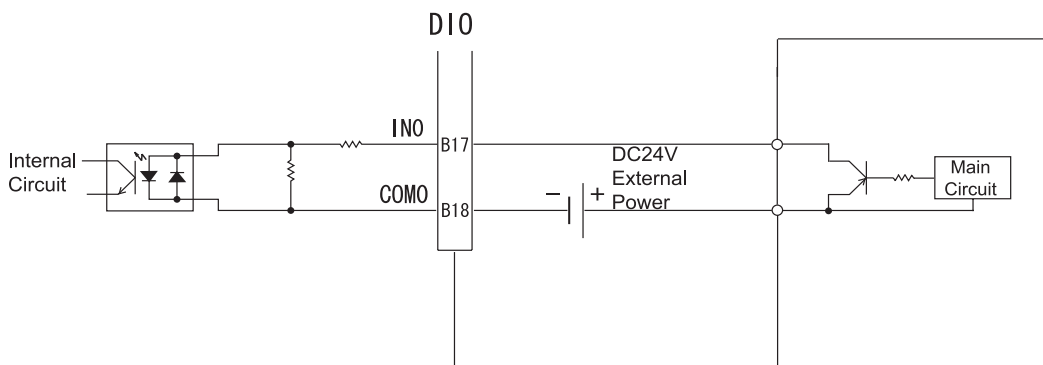

Note: Pin Numbers B11, B13, B15, and B17 can be used as the counter input terminals in the LT unit.

Reference *LT Type H I/O Setting User Manual (sold separately).*

3.3 Tool Connector

A data transfer cable or a bar-code reader can be attached to the LT unit's tool connector. A serial printer can be connected with a data transfer cable and a user-customized conversion cable. The location of the LT unit's tool connector is shown in the following diagram.



WARNING

To prevent electrical shock, unplug the LT unit's power cord from the main power supply prior to attaching or detaching any LT connectors.

Side View

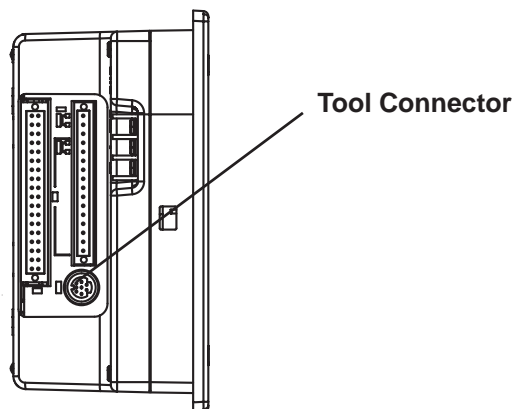

When the Bar Code Reader uses a separate power supply:

- Turn the Bar Code Reader ON before turning the LT ON.
- Turn the LT OFF before turning the Bar Code Reader OFF.

3.3.1 Serial Printer Connection

■ Overview

The LT unit outputs to a printer via the tool interface. Use the optional data transfer cable to connect to the user-created conversion cable, and connect that cable to the serial printer's connector.

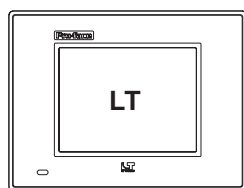

Data Transfer Cable

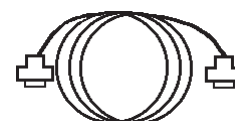
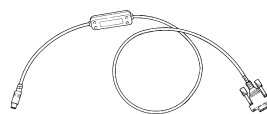

Conversion Cable
(user-created)

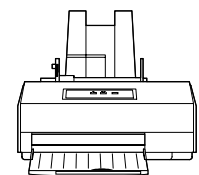

Serial Printer

Chapter 3 – Installation and Wiring

■ Project Manager Setup

Select [Screen/Setup]-[System Setup] in the Project Manager. The printer output can be executed via Tool Connector by configuring the settings on the I/O Settings tab of the [System Setup] dialog box as shown below.

C-Package: Select the Keyboard Serial option for the Printer port setting.

LT Editor: Select the Used option for the Print from Tool Connector setting.

Depending on the connected serial printer, the Type setting and the Keyboard SIO Baud Rate setting will differ.

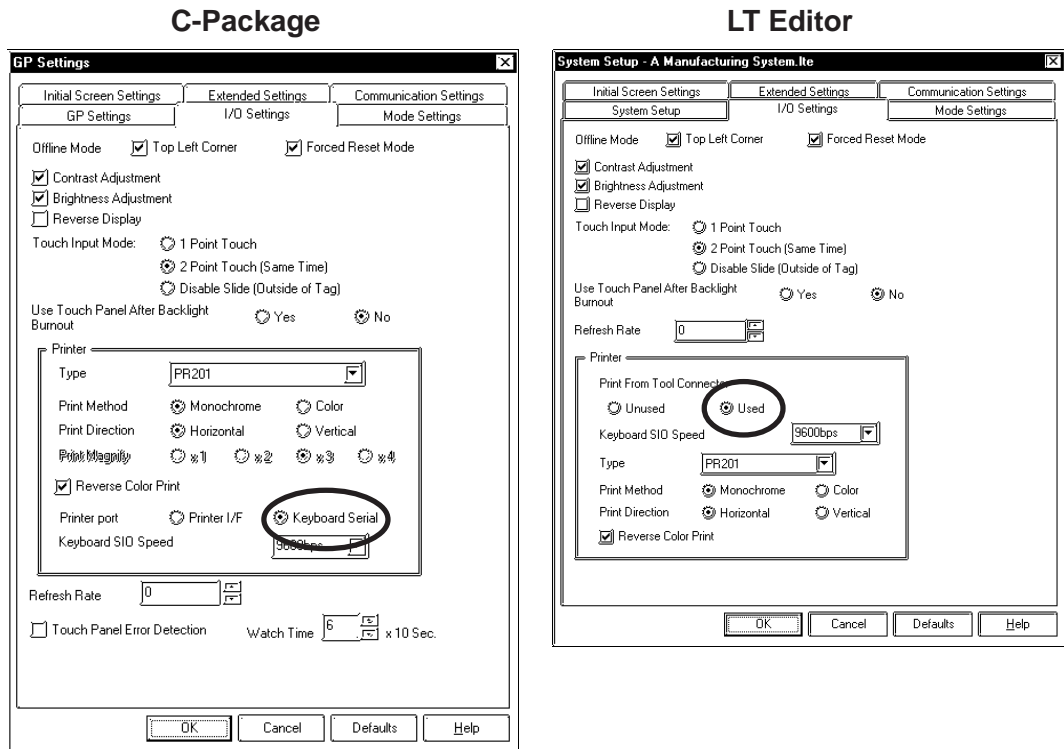

■ Data Transfer Cable (Dub 9-Pin) Specification

The data transfer cable (Model: GPW-CB02) uses a socket-type connector. The cable's pins are assigned as follows:

Pin Assignments	Pin No.	Signal Name
	1	DTR
	2	TXD
	3	RXD
	4	DSR
	5	GND
	6	RTS
	7	CTS
	8	RTS
	9	



Note: Use inch type set screws (#4-40 UNC).

Chapter 3 – Installation and Wiring

■ HP Laser Jet 4PJ Printer

◆ Conversion Cable Wiring Diagram

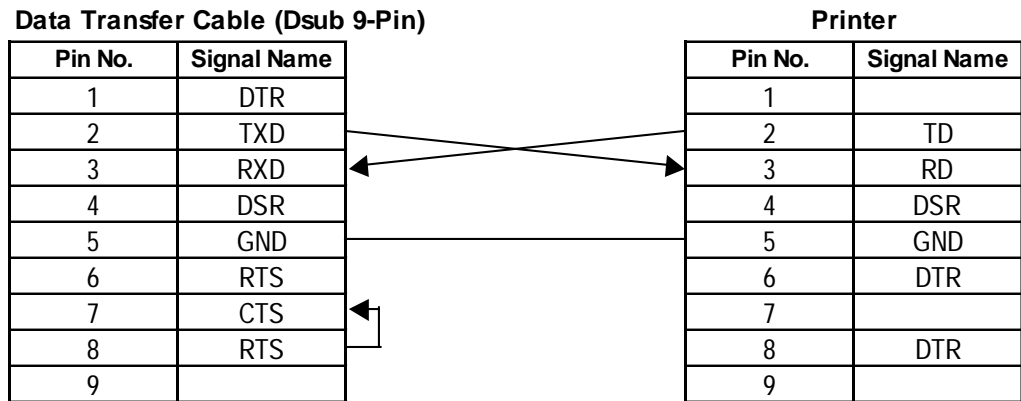

◆ Printer Type Settings Area – Type and Keyboard SIO Baud Rate

Type: HP Laser Jet II

Keyboard SIO Baud Rate: 9600bps

◆ Printer Settings

Serial Menu		PCL Menu		Job Menu	
Serial	RS-2332	Font Source	I (build-in)	Resolution	600
Protocol	Xon/Xoff	Font No.	1	Serial	PCL
Baud Rate	9600	Size	12	Timeout	15
RobustXon	OFF	Symbol	WIN3.1		
DTR Polarity	HI				

◆ Available Printout Features

Printout Features	Availability		
	Japanese	I-ASCII	Korean / Taiwanese / Chinese
Screen Hard Copy	0	0	0
Print Alarm Message	0	0	0
Real-time Log Data Print	0	0	0
Print Log Data (Single Block)	0	0	0

■ NADA Electronics TP-651G Printer (Ver. 1.3)

◆ Conversion Cable Wiring Diagram

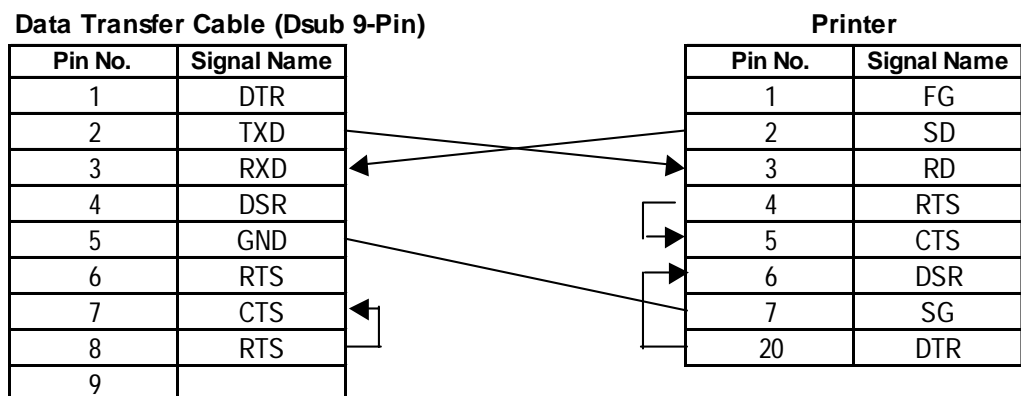

Chapter 3 – Installation and Wiring

◆ Printer Type Settings Area – Type and Keyboard SIO Baud Rate

Type: Epson (High Quality)

Keyboard SIO Baud Rate: 19200bps

Printing Method: monochrome

◆ Printer Settings

DIP SW1

Switch	Feature	ON/OFF
SW1-1	LISTER P PRINT	OFF
SW1-2	Buffer Full Print	OFF
SW1-7	Graphic Double Height Printing	ON
SW1-8	Exclusive Graphic 800 x 600 dot printing	OFF

DIP SW2

Switch	Feature	ON/OFF
SW2-1	Baud Rate: 19200bps	ON
SW2-2		ON
SW2-3	Data Bit Length: 8 bits	OFF
SW2-4	Parity: Invalid	OFF
SW2-5	Parity: EVEN	OFF
SW2-6	Stop Bit: 1 bit	OFF
SW2-7	XON/XOFF TYPE	ON
SW2-8	Print Interval: 1 second	OFF

◆ Available Printout Features

The printout features available with the LT unit are listed as follows:

Printout Features	Availability		
	Japanese	I-ASCII	Korean / Taiwanese / Chinese
Screen Hard Copy	0	0	0
Print Alarm Message	0	0	0
Real-time Log Data Print	0	0	0
Print Log Data (Single Block)	0	0	0

■ EPSON TM-U210D Printer

◆ Conversion Cable Wiring Diagram

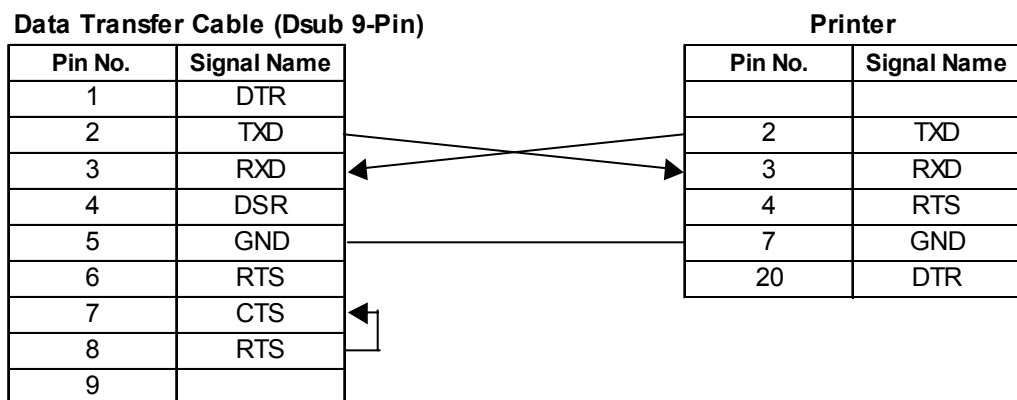

Chapter 3 – Installation and Wiring

◆ Printer Type Settings Area – Type and Keyboard SIO Baud Rate

Type: EPSON (High Quality / High Speed)

Keyboard SIO Baud Rate: 9600bps

◆ Printer Settings

DIP Switch Set 1

Switch	Function	ON/OFF
SW1-1	Data reception error	Prints"?" marks
SW1-2	Receive buffer capacity	Approx. 1KB
SW1-3	Handshaking	XON/XOFF
SW1-4	Word length	8bits
SW1-5	Parity check	No
SW1-6	Parity selection	Odd
SW1-7	Baud rate	9600bps
SW1-8	Busy condition	Sets the printer to BUSY when it is offline or when the receive buffer is full

DIP Switch Set 2

Switch	Function	ON/OFF
SW2-1	Print column selection 7x9 font / 9x9 font	40/33
SW2-2	Internal use. Setting must not be changed (fixed to OFF).	
SW2-3	Internal use. Setting must not be changed (fixed to OFF).	
SW2-4	Undefined.	
SW2-5	Internal use. Setting must not be changed (fixed to OFF).	
SW2-6	Internal use. Setting must not be changed (fixed to OFF).	
SW2-7	I/F pin 6 reset signal	Disabled
SW2-8	I/F pin 25 reset signal	Enabled

◆ Available Printout Features

Printout features available with the LT unit are as follows:

Printout Features	Availability		
	Japanese	I-ASCII	Korean / Taiwanese / Chinese
Screen Hard Copy	X	X	X
Print Alarm Message	X	0	X
Real-time Log Data Print	X	0	X
Print Log Data (Single Block)	X	0	X

Chapter 3 – Installation and Wiring

■ CUSTOM FT190SP Printer

◆ Conversion Cable Wiring Diagram

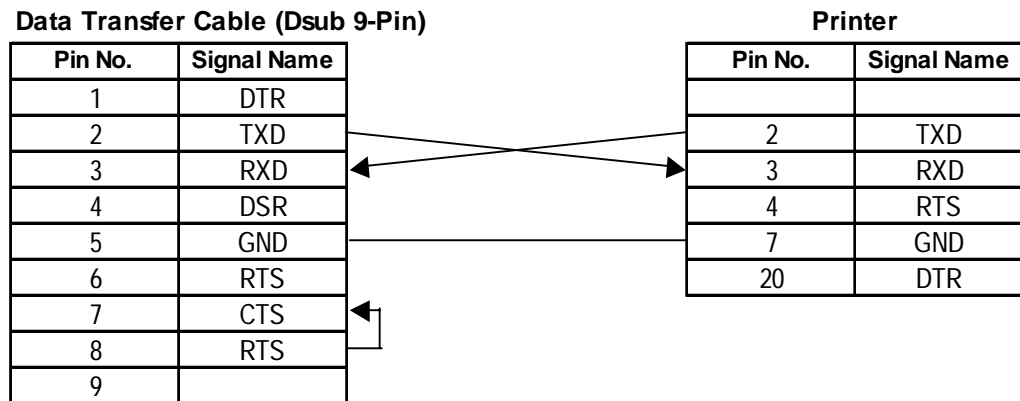

◆ Printer Type Settings Area – Type and Keyboard SIO Baud Rate

Type: Epson (High Quality/High Speed)

Keyboard SIO Baud Rate: 19200bps

◆ Printer Settings

SET UP DEFAULT:

40 COLUMNS (font 9x24)

PRINT = REVERSE

MODE = LITTLE

FONT 2

CR-LT IGNORE CR

SPEED/CURRENT = LOW

BUFFER 1K BYTE

SERIAL PORT SELECTED

BAUD RATE = 9600

PROTOCOL = 8, N, 1

FLOW CONTROL = XON-XOFF

PRINT KEY TRANSMIT \$0D

◆ Available Printout Features

The following table lists printout features available with the I-ASCII font.

Japanese, Korean, Taiwanese, and Chinese fonts are not available.

Printout Features	Availability		
	Japanese	I-ASCII	Korean / Taiwanese / Chinese
Screen Hard Copy	X	X	X
Print Alarm Message	X	O	X
Real-time Log Data Print	X	O	X
Print Log Data (Single Block)	X	O	X

Chapter

4 Data Transfer

1. SERIAL DATA TRANSFER
2. OFFLINE Mode Main Menu
3. INITIALIZATION

This chapter explains how to transfer data created with the LT Editor/C-Package to or from the LT unit. Transfer data via the data transfer cable between the LT and the PC.

4.1 Data Transfer Cable

The following diagram illustrates the data transfer cable connection between your PC and the LT.

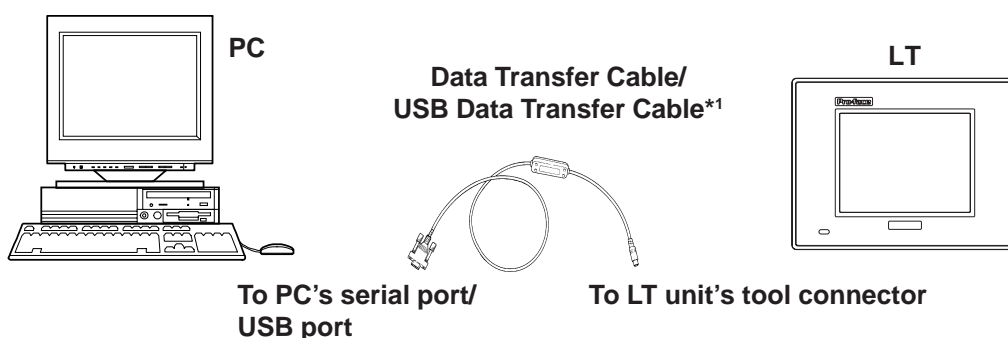

- Sending the project file to the LT requires the Data Transfer cable (GPW-CB02), which is sold separately.
- The I/F conversion adapter is not included with the LT. However, if necessary, you can purchase this adapter at a computer supply store.



- Pro-face's serial data transfer cable (GPW-CB02) and USB data transfer cable (GPW-CB03) are sold separately. However, the data transfer cable package does NOT include the PC's interface conversion adapter.
- When using the PC with the Dsub 25-pin socket (female) interface, a connector conversion adapter is required. Use the straight-line type of conversion adapter.
Recommended adapters:
Abel Co. AA833
Sanwa Supply Co. D09-9F25F
- When using a PC equipped with a half-pitch, 14-pin socket interface, a conversion adapter is required.
Recommended adapter:
Loas Co. ZR01-024

1 Software version limitations apply.

Reference For details, *USB Data Transfer Cable Installation Guide*.

4.2 Transferring Screen Data

Transfer screen data from your PC via the LT Editor/C-Package.

Reference *LT Editor Operation Manual – Screen Creation Guide, GP-PRO/PBIII Operation Manual (included with the C-Package software)*

■ Transferring Data to a New LT

Connect the LT to your PC with the data transfer cable, and then turn the LT unit ON. The [Read me first!] screen appears on the LT unit, and then automatically changes to the [TRANSFER SCREEN DATA] screen. After this screen appears, you can transfer screen data from the LT Editor/C-Package software to the LT.



■ Completing Data Transfer*1

When transferring screen data from the LT Editor/C-Package, the screen automatically switches to TRANSFER SCREEN DATA. If the screen does not switch to TRANSFER SCREEN DATA, select TRANSFER SCREEN DATA mode.

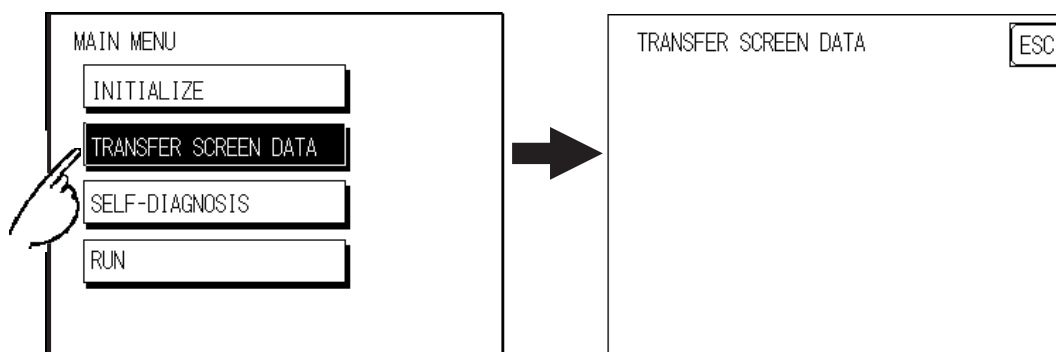

*1 The LT must be prepared for the data transfer process before the data can be transferred. To do this, be sure to download the system program and the protocol program from the LT Editor/C-Package to the LT unit.

During data transfer, the SETUP TRANSFER, NOW TRANSFERRING – PLEASE WAIT, and NOW WRITING – PLEASE WAIT messages appear. When these messages disappear, the screen data transfer has completed.

When the screen data transfer has completed, if you do not need to set up the LT, the screen designated in the INITIAL SCREEN NO. setting of the [INITIALIZE] menu's [SCREEN SET UP] screen appears, and the screen changes to RUN mode.

You can cancel data transfer at any time using your LT Editor/C-Package software's Transfer screen.



Interrupting the screen data transfer can lead to an LT startup error.

During screen data transfer, do NOT:

- **disconnect the LT unit's power supply**
 - **turn off the PC**
 - **disconnect the LT unit's transfer cable**
-



If the LT Editor/C-Package's SYSTEM SETUP data is transferred to the LT, the OFFLINE mode INITIALIZE data will be overwritten.

Memo

Chapter

5 OFFLINE MODE

1. Entering OFFLINE Mode
2. OFFLINE Mode Main Menu
3. INITIALIZATION
4. SELF-DIAGNOSIS

OFFLINE Mode provides access to the LT unit's [INITIALIZE] menu, [SELF-DIAGNOSIS] menu, and other LT features. You need to change the LT to OFFLINE mode before you can use any of these features.



OFFLINE mode is unavailable in a new LT until the necessary System data has been transferred from your LT Editor/C-Package. To transfer system data, the LT must be ON. When the screen data files are transferred from the LT Editor/C-Package to the LT, the System screen data is also automatically sent.

Reference *LT Editor Operation Manual – Screen Creation Guide, GP-PRO/PBIII Operation Manual (included with the C-Package software)*

5.1 Entering OFFLINE Mode



- When the Logic Program is changed from RUN to OFFLINE mode, the output hold setting is turned OFF. Be sure to take this into consideration before changing to OFFLINE mode or resetting the unit. Also, when the unit is reset, the I/O signal's OFF timing will not be set.
- Be aware that when changing a Logic Program from RUN to OFFLINE mode, regardless of the current output hold setting, the LT unit's and the I/O signals' processing is as follows:

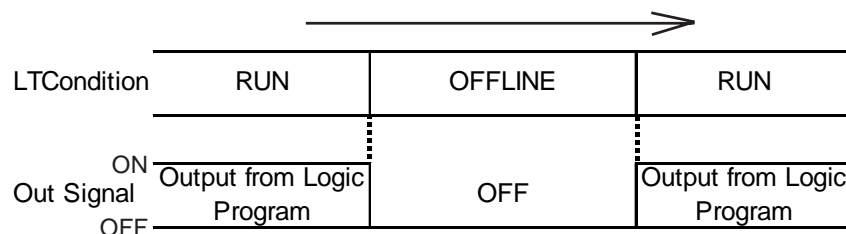

In order to initialize the LT or perform any self-diagnostics, you must change the LT to OFFLINE mode. The following explanation explains the two ways to enter this mode.

Chapter 5 – OFFLINE Mode

5.1.1 After Plugging in the Power Cord

To enter OFFLINE mode, touch the top-left corner of the screen within 10 seconds after connecting the LT unit's power cord.

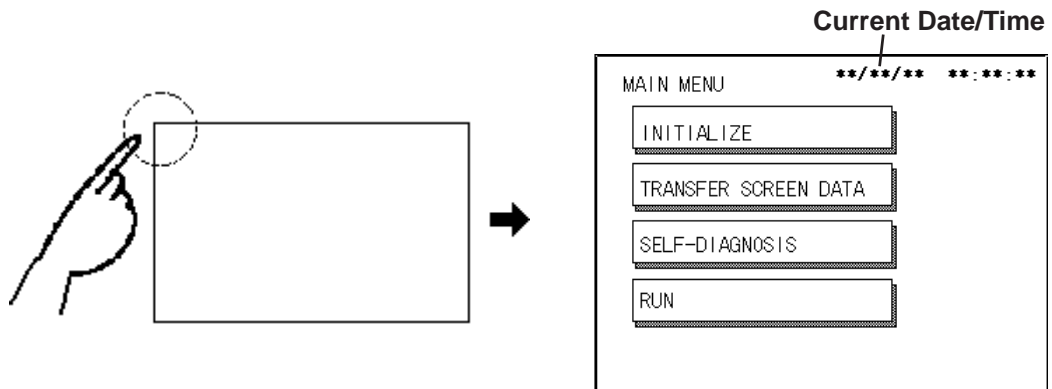

5.1.2 From the Menu Bar

From the LT unit's menu bar, touch OFFLINE, and the [MAIN MENU] appears.

Reference 6.4.3 – “SET UP TOUCH PANEL”

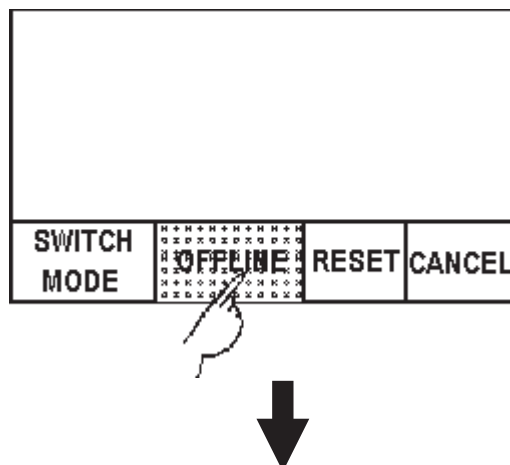

Entering OFFLINE mode will reset the LT unit's I/O. After confirming that this will not cause any problems, touch YES.

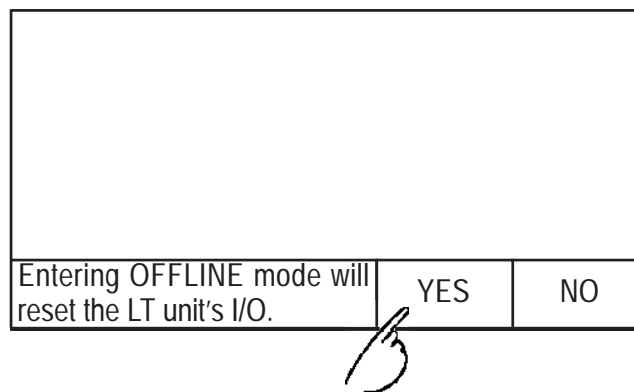

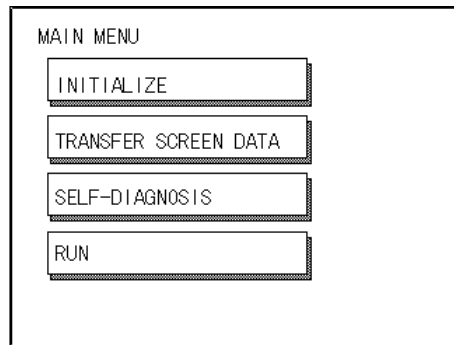

Enter the Password, then touch SET to enter OFFLINE mode.

If you try to enter a Password in the [INITIALIZE] menu's SET UP SYSTEM area before entering OFFLINE mode, the following screen appears:

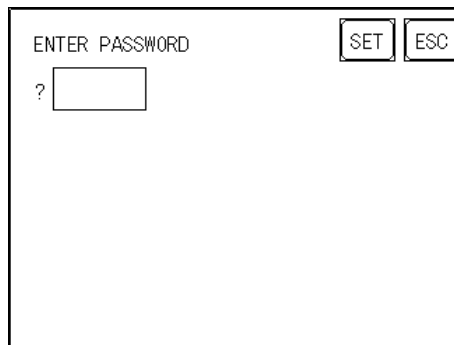

Reference 6.3.1 – “SYSTEM SETUP”
5.3 – “INITIALIZATION”

5.2 OFFLINE Mode - MAIN MENU

The [MAIN MENU] contains the following menu items: [INITIALIZE], [TRANSFER SCREEN DATA], [SELF-DIAGNOSIS], and [RUN].

The settings for each menu item, below, must match the corresponding connection device, for the LT to communicate properly.

Entering OFFLINE mode calls up the following screen.

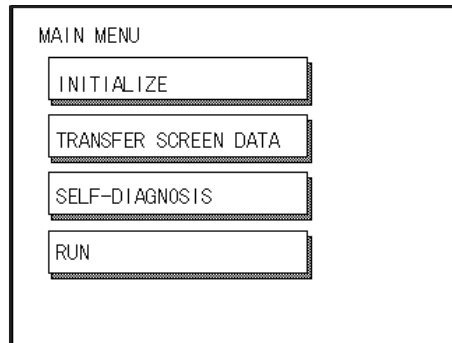

Select the desired menu item by touching the corresponding option.

Each Main Menu item is used as follows:

INITIALIZE

Sets up control of the LT unit.

SCREEN DATA TRANSFER

Transfers screen data between the LT Editor/C-Package and the LT.

SELF-DIAGNOSIS

Checks to see if there are any problems with the LT unit's system or interface.

RUN

Starts the LT operation.

Reference Chapter 6 – “Initializing the LT”

LT Editor Operation Manual – Screen Creation Guide (included with the LT Editor software), GP-PRO/PBIII Operation Manual (included with the C-Package software)

Chapter 7 – “LT Run Mode and Errors”

5.3 INITIALIZATION

■ Selecting Menu and Setting Items

Touch a menu item to select that menu. Touch a setting item to select its input field.

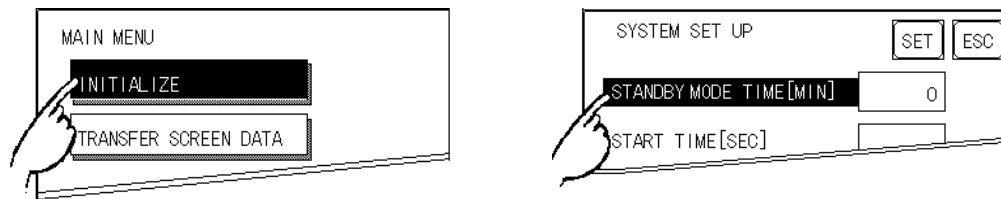

■ Entering Numbers

After selecting an input field, touch the numeric touch keys located at the bottom of the screen to enter the value of the selected item. After entering each input field's numeric value, touch the SET key to register the value.

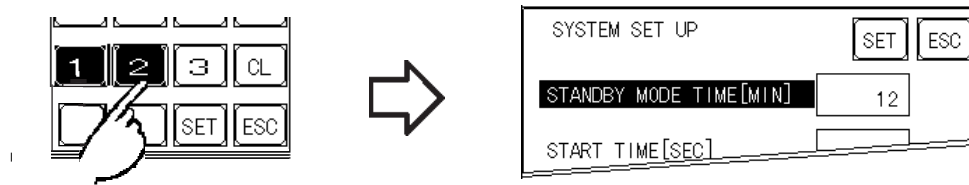

■ Selecting Setup Conditions

After selecting a menu item, touch the setting option to highlight the item, and touch the setting area to set the condition for that item.

In this example, touching the ON/OFF area toggles the TOUCH BUZZER SOUND setting, which is set to OFF, and then switched to ON.

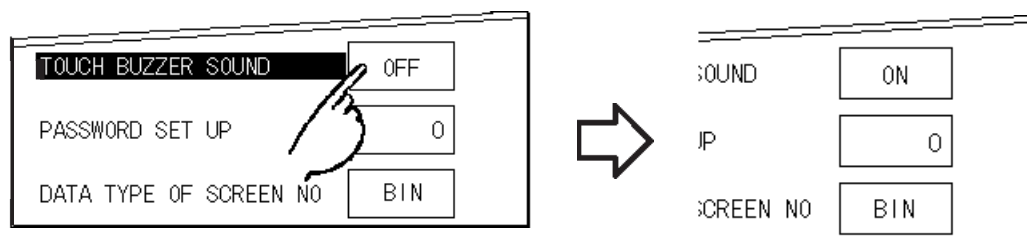

Chapter 5 – OFFLINE Mode

■ After Entering All Setting Data

Touch the SET key to write the setup data to the Internal FEPRM.



After entering the Setup data, do NOT touch the screen until the previous menu reappears. Writing the Setup conditions to the Internal FEPRM is a process that requires a short period of time to complete.

Touch CANCEL to cancel the setup, exit the screen without saving the changes, and return to the previous menu.

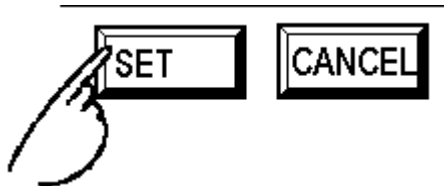

■ Returning to a Previous Screen

Touch the tab to call up the desired menu.

For example, to return to the [MAIN MENU] from the [SYS. ENVIRONMENT] screen, touch the [MAIN MENU] tab.

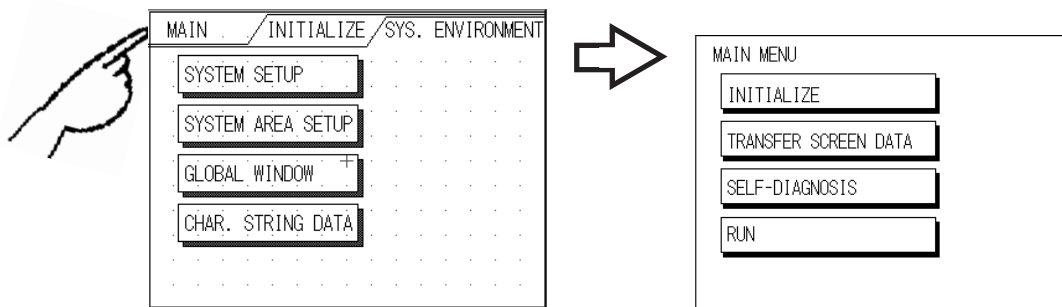

5.4 SELF-DIAGNOSIS

■ Selecting a Sub-Menu

Touch the desired menu item, and that sub-menu appears.



■ Using the SET and ESC Keys

After selecting the Self-Diagnosis item, the SET and ESC keys may appear at different times at the top of the screen.

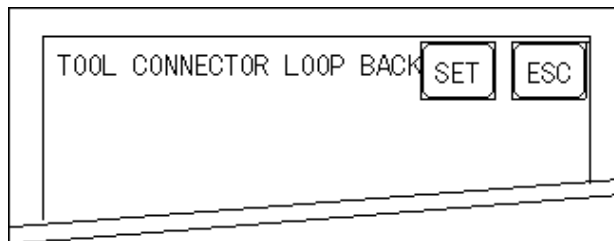

◆ SET Key

When the SET key is touched, the Self-Diagnosis test begins.

◆ ESC Key

When the ESC key is touched, the Self-Diagnosis test is cancelled, and the [SELF-DIAGNOSIS] menu returns.

Chapter 5 – OFFLINE Mode

■ Returning to the [SELF-DIAGNOSIS] Menu

After performing the Self-Diagnosis check, OK is displayed. Touch once anywhere on the display screen to return to the [SELF-DIAGNOSIS] menu.

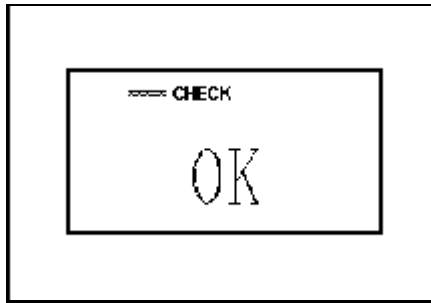

If an Error Message displays, press the bottom-left corner of the panel [1], and then touch the bottom-right corner of the panel [2] to return to the [SELF-DIAGNOSIS] menu.

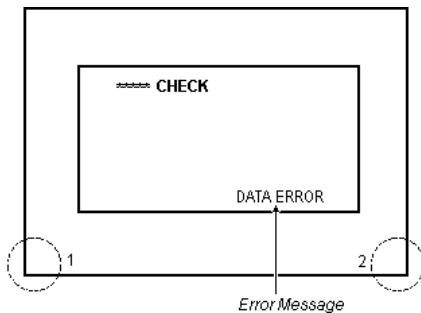

■ Returning to the [MAIN MENU]

Touch the [MAIN] tab in the top-left corner of the [SELF-DIAGNOSIS] menu to return to the [MAIN MENU].

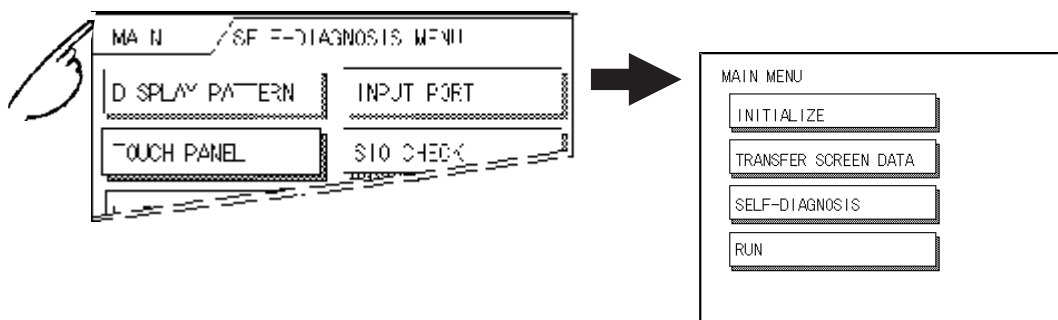

Chapter

6 Initializing the LT

1. Initialization Screen
2. Initialization Items
3. SYSTEM ENVIRONMENT SETUP
4. SET UP I/O
5. OPERATION ENVIRONMENT SETUP
6. INITIALIZE INTERNAL MEMORY
7. SET UP TIME
8. SET UP SCREEN
9. FONT SETTING

6.1 Initialization Screen

To change your LT unit's general operation settings, use the LT unit's OFFLINE mode to access the items in the INITIALIZE option of the [MAIN MENU] screen.



Note:

When you transfer your LT Editor/C-Package's system file¹, the LT operates using that file's data. If the LT System file is correctly set up and transferred, then setting up the INITIALIZE settings is unnecessary.

Reference *LT Editor Operation Manual – Screen Creation Guide (included with the LT Editor software), GP-PRO/PBIII Operation Manual (included with the C-Package software)*

¹ The information contained in the LT Editor/C-Package's system file is set by the software's "System Setup".

6.2 Initialization Items

The contents of the Initialize menu's submenus (below) are explained in this Chapter.

Reference Chapter 5 – “OFFLINE Mode”

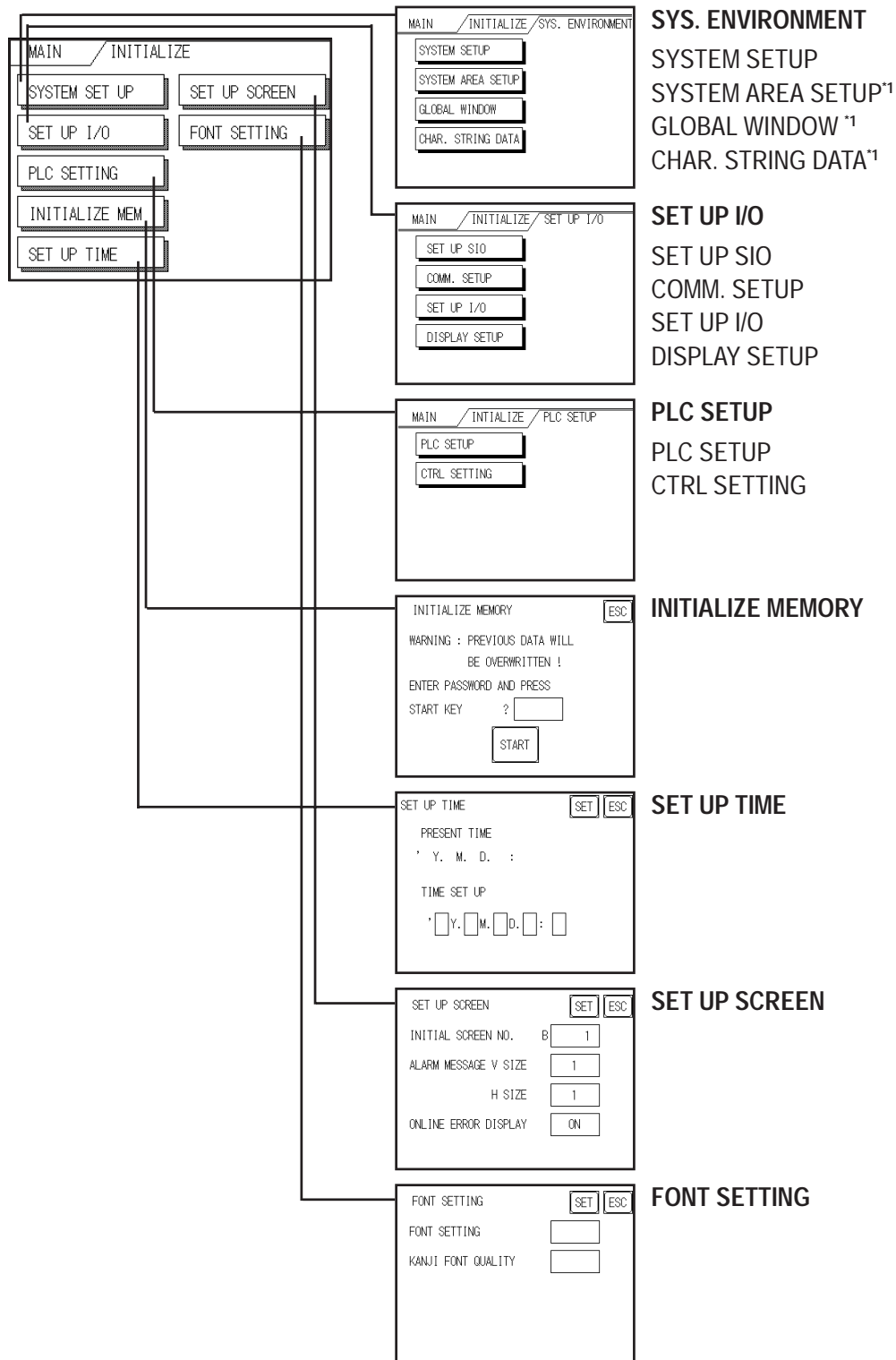

^{*1} This feature is not available.

6.3 SYSTEM ENVIRONMENT SETUP

LT environment adjustments are made in the setup screens contained in the [SYSTEM ENVIRONMENT SETUP] menu, which includes the [SYSTEM SETUP] screen.



Note: The [SYSTEM AREA SETUP] and [GLOBAL WINDOW SETUP] and [CHAR.STRING DATA SETUP] features are not available.

6.3.1 SYSTEM SETUP

SYSTEM SET UP		SET	ESC
STANDBY MODE TIME[MIN]	<input type="text" value="0"/>		
START TIME[SEC]	<input type="text" value="0"/>		
TOUCH BUZZER SOUND	<input type="text" value="ON"/>		
PASSWORD SET UP	<input type="text" value="0"/>		
DATA TYPE OF SCREEN NO	<input type="text" value="BIN"/>		

STAND-BY MODE TIME (0–255)

To protect the LT unit's display screen, a screen saver function automatically turns the unit's backlight(s) OFF when no operations have occurred within a specified period of time. No screen saver will be used when "0" is entered in this field.

When the System Data Area's [SCREEN DISPLAY OFF]*1 data is set to **0000h**, the LT unit's current display data will clear if the following operations are not performed within the user's specified period of time.

- Change Screen
- Touch Screen
- Alarm Display

START TIME (0–255)

Use this setting item to specify the LT unit's startup time — or to adjust the powering-up sequence — so that the LT starts up *after* the external devices start.

TOUCH BUZZER SOUND

Use this feature to indicate with a buzzing sound that the LT has been touched.

PASSWORD SETUP

The password setting item is used when the LT switches to the [INITIALIZE MEMORY] or Initialize (OFFLINE mode) screens. The password — a number between **0** and **9999** — is a security feature within the OFFLINE mode, to protect the LT settings. If you do not wish to use this feature, enter the default value, "0."

*1 When using the Direct Access format, the object address becomes LS0009. When using the Memory Link format, the object address becomes +12 (only when all items are set within the System Data Area).

Reference *LT Editor Device Connection Manual* (included with the LT Editor software), *GP-PRO/PBIII Device/PLC Connection Manual* (included with the C-Package software)

Chapter 6 – Initializing the LT

DATA TYPE OF SCREEN NO.

This setting specifies whether [BIN] or [BCD] format numbers are used when making screen changes.

6.4 SET UP I/O

This section describes the communication setup and the configuration for any peripheral equipment. The [SET UP I/O] menu includes the [SET UP SIO], [COMM. SETUP], [SET UP I/O], and [DISPLAY SETUP] screens.



Note: The [SET UP SIO] and [COMMUNICATION SETUP] setting items are invalid.

6.4.1 SET UP TOUCH PANEL

This screen is where you can set up the touch panel's Touch Operation and System Reset modes, and adjust the Display settings.

◆ When using a monochrome model:

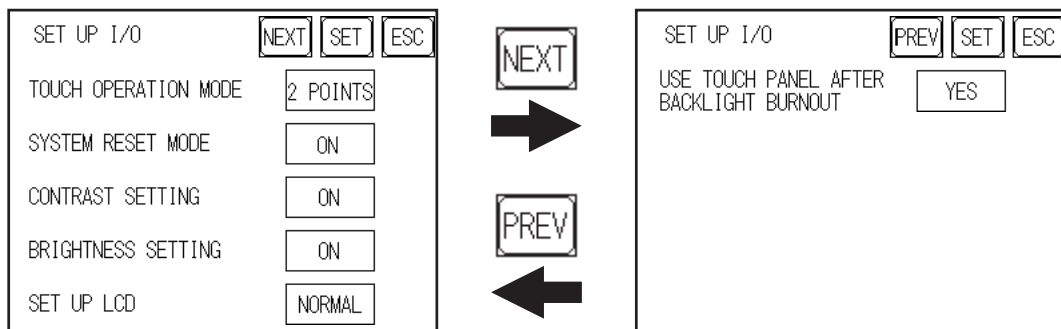

◆ When using a color model:

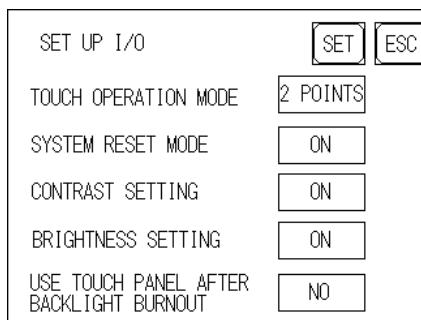

TOUCH OPERATION MODE

Designates either [One Point], [Two Points], or [No Slide].

1 Point Touch	Designates that the touch panel accept only 1-point touch input. As soon as touch screen contact is released, touch input is cancelled.
2 Point Touch	Designates that the touch panel accept only 2-point touch input. If three or more points are touched simultaneously, input is not accepted and touch input cannot be cancelled. In a single switch, up to two points can be touched.
No Slide	Designates that the touch panel accept only 1-point touch input. If two or more points are touched simultaneously, input is not accepted and touch input cannot be cancelled. Input is cancelled if the touch moves (slides) outside the current "active" area.

SYSTEM RESET MODE

This setting allows the user to enable or disable the System Reset menu bar. When set to YES, the menu bar will display.



You can perform SYSTEM RESET regardless of whether the LT unit is operating in RUN mode or in OFFLINE mode.

◆ To Display the Menu Bar

To enter the SYSTEM RESET mode, press the bottom-right corner of the screen (position 1, below), and then touch the top-right and bottom-left corners (positions 2 and 3).

To activate Reset, touch the RESET button; to change to OFFLINE Mode, touch OFFLINE.

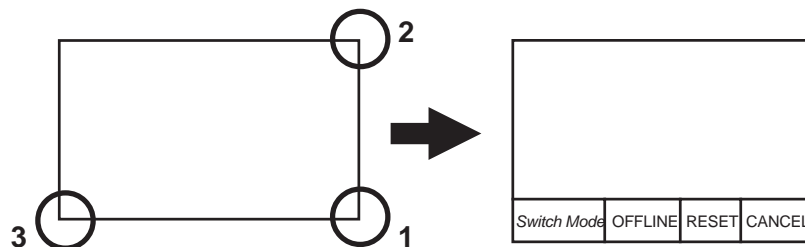

- The menu bar will not display while the LT is starting up.
- Entering SYSTEM RESET is possible even when the external device and the LT are communicating.

Chapter 6 – Initializing the LT

CONTRAST SETTING

When CONTRAST SETTING is set to ON, you can adjust the contrast by touching the LT unit's screen. To adjust the Contrast mode, press the screen's top-left corner (screen A, position 1, below), and then touch the top-right corner (screen A, position 2). When the contrast adjustment screen (B) appears, touch to select the desired level of brightness, and the screen's contrast will adjust according to your changes.

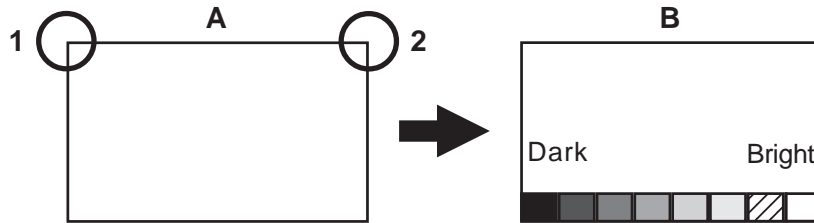

Note:

- To exit the CONTRAST SETTING mode, touch anywhere above the Contrast Setting bar.
- You cannot enter the CONTRAST SETTING mode while waiting for the LT to start up.
- CONTRAST SETTING adjustments (LT and external devices) can be made during RUN mode.

BRIGHTNESS SETTING

The brightness control function is unavailable and the setting is invalid in the LT unit.

SET UP LCD

This setting reverses the colors of the LT unit's display screen and characters.

To reverse the screen's display, touch [SET UP LCD] on the [SET UP I/O] screen to change the setting from NORMAL to REVERSE, and then touch the SET key.

The display color reverses and the [SET UP I/O] menu reappears.

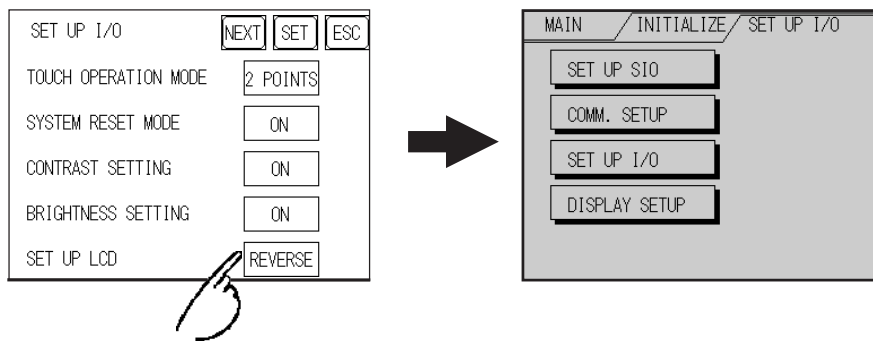

USE TOUCH PANEL AFTER BACKLIGHT BURNOUT

Access this setup screen by touching NEXT. This setting allows the user to enable or disable the touch operation when the backlight burns out. Setting this item to [NO] prevents the LT from sending input signals to the connected devices. This setting is disabled (set to NO) during shipment.



Note:

When the Backlight Burns Out:

- The Status LED's orange light will turn ON.
- The System Data Area's Status bit 10*1 will turn ON.
- If the SYSTEM RESET item is set to ON, only SYSTEM RESET can still be performed by touch operation.
- If the LT is in OFFLINE mode, the touch-panel operation will become enabled, regardless of the settings.



Normally, the unit detects backlight burnout by monitoring the current; however, depending on the problem with the backlight, the unit may fail to detect this condition.

*1 When using the Direct Access format, the object address becomes Bit +6. When using the Memory Link format, the object address becomes +11 (only when all items are set within the System Data Area).

Reference *LT Editor Device Connection Manual* (included with the LT Editor software), *GP-PRO/PBIII Device/PLC Connection Manual* (included with the C-Package software)

Chapter 6 – Initializing the LT

6.4.2 DISPLAY SETUP

The LT unit's screen may flicker, or the LCD's surface may appear to have shadows on extended display lines. This effect may be more pronounced when the LT unit's ambient temperature is high, and its current level of brightness is set to low. This phenomenon, however, is a common attribute of LCDs and is not a defect.

To solve this problem, use the Display Setup screen to adjust the LT unit's brightness.

When using a monochrome model:

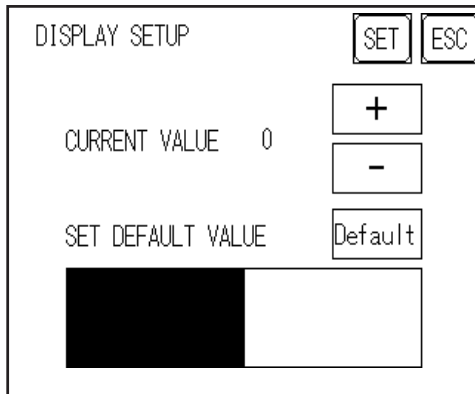

When using a color model:

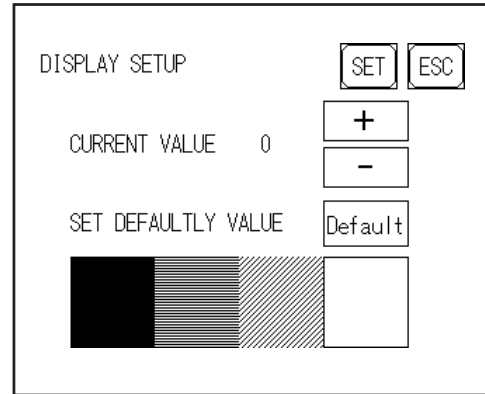

CURRENT VALUE

Touch [+] or [-] to adjust the levels of brightness (18 levels of [+] and two levels of [-] brightness). You can check the brightness level in the preview field at the bottom of the screen. The default value of brightness is “0.”

SET DEFAULT VALUE

If you touch [Default], the setting returns to “0.”

6.5 OPERATION ENVIRONMENT SETUP

This section describes the operation environment setup and the controller settings.

6.5.1 SET UP OPERATION ENVIRONMENT

This setup is not valid with the LT Type H unit. Return to the previous screen by clicking the Main menu button.

6.5.2 CONTROLLER SETTINGS

This section describes the Controller setting items. The [CTRL MENU] includes the [CTRL SETTING], [CTRL DIAGNOSIS], and [TYPE H DRIVER] setup screens.

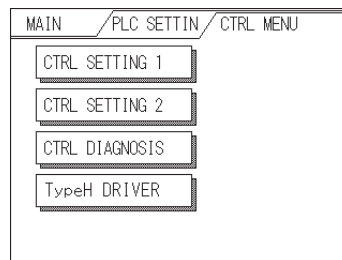

Information set via LT Logic Program Editor/C-Package or Controller Settings is stored in the LT unit's nonvolatile memory. Although each item in the Controller Settings screen has a default setting, each should be set to match your application.

■ CONTROLLER SETTING

Controller Setting 1

CONTROLLER SETTING 1	DEF.	SET	ESC
TARGET SCAN TIME (10-2000ms)	<input type="text"/>	ms	
PERCENT ALLOCATION (0-50%)	<input type="text"/>	%	
CONTROLLER STATE	<input type="text"/>		
STOP ON MINOR FAULT	<input type="text"/>		
WATCHDOG TIMER (100-3000ms)	<input type="text"/>	ms	

Controller Setting 2

CONTROLLER SETTING 2	DEF.	SET	ESC
CHANGE SCREEN CHECK	<input type="text"/>		

CONTROLLER SETTING 1

TARGET SCAN TIME

Use Target Scan Time to set the time periods for the Controller and the Display operation time functions. The setting range for Target Scan Time is between 10 and 2000 ms.

The Controller Operation Time function sets the time it takes to execute the I/O reading, Logic Program, and I/O writing. When Target Scan is set, the maximum time allocated to the Controller Operation Time function is 50%.

Reference *LT Editor Operation Manual – Logic Programming Guide* (included with the LT Editor software), *Pro-Control Editor User Manual* (included with the C-Package software)

Chapter 6 – Initializing the LT

PERCENT ALLOCATION

Use Percent Allocation to set the ratio of Controller Operation Time Function in Target Scan Time. The setting range for Percent Allocation is between 0 and 50%. When Percent Allocation is set, Target Scan is disabled.

Reference *LT Editor Operation Manual – Logic Programming Guide* (included with the LT Editor software), *Pro-Control Editor User Manual* (included with the C-Package software)

CONTROLLER STATE

This item sets the Operation Mode — Default, Run, or Stop — when the power is ON.

The Controller State setting is valid only when the RUN/STOP switch on the back of LT is set to Run. When the switch is set to Stop, the Operation Mode will always be Stop, regardless of this setting's value.

STOP ON MINOR FAULT

This item either stops the Controller or executes a logic program when a minor fault occurs. If you wish operation to continue after a fault occurs, set this switch to Continue; if you wish to stop operation, set it to Stop.

Reference *LT Editor Online Help, Pro-Control Editor Online Help*

WATCHDOG TIMER

Sets the Watch Dog Timer (WDT) for the Controller Operation Time and the LT Operation Time functions to between 100 and 3000 ms. Input the value in units of 100 ms. Inputting “0” is invalid.

CONTROLLER SETTING 2

CHANGE SCREEN CHECK

After #Screen is used to perform the screen change, the #Screen setting value is reset to “0”. Using the ON (initial) setting will clear the #Screen value to “0”.

Reference *LT Editor Operation Manual – Logic Programming Guide* (included with the LT Editor software), *Pro-Control Editor User Manual* (included with the C-Package software)

■ CONTROLLER DIAGNOSIS

Reference 7.3.3 – “List of Controller Self-Diagnostics Items”

■ TYPE H DRIVER

[TYPE H DRIVER] menu includes the [TERMINAL ASSIGN.], [I/O MONITOR], and [I/O BOARD CHECK] screens.

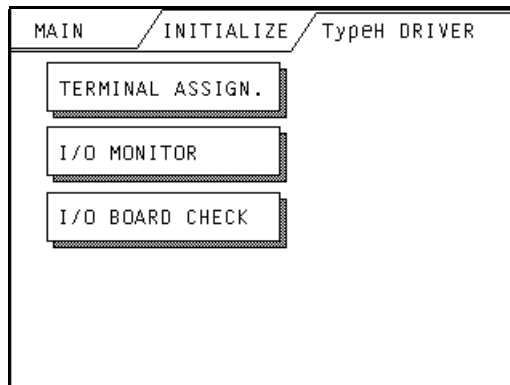

◆ TERMINAL ASSIGNMENT DISPLAY

This item displays the current set terminal assignments of the input terminals X0 to X7, and output terminals Y0 to Y7. The terminal assignments set up in the LT Editor/C-Package's [Configure I/O] will register after you download the logic program that has been set to Enable I/O.

Reference *LT Editor Operation Manual – Logic Programming Guide (included with the LT Editor), Pro-Control Editor Operation Manual (included with the C-Package software)*

TERMINAL ASSIGNMENT DISPLAY				RET
COUNTER INPUT	X0	Y0	SYNCH. OUTPUT	
DIN	X1	Y1	PWM OUTPUT	
DIN	X2	Y2	DOUT	
DIN	X3	Y3	PULSE OUTPUT	
COUNTER INPUT	X4	Y4	DOUT	
DIN	X5	Y5	DOUT	
DIN	X6	Y6	DOUT	
DIN	X7	Y7	DOUT	
X8-X15:DIN		Y4-Y15:DOUT		
Y0-Y7 :200mA Output		Y8-Y15:500mA Output		

◆ I/O MONITOR

Standard input, standard output, analog input, analog output, thermocouple input, and Pt100 input operations can be checked by each type of I/O.

- (I) DIO
- (II) Analog Input
- (III) Analog Output
- (IV) Thermocouple Input
- (V) Pt100 Input

To switch screens for each type of I/O, touch I/O Type or DIO (shown below). The screens change in the following order: DIO → Analog Input → Analog Output → Thermocouple Input → Pt100 Input → DIO ...

Chapter 6 – Initializing the LT

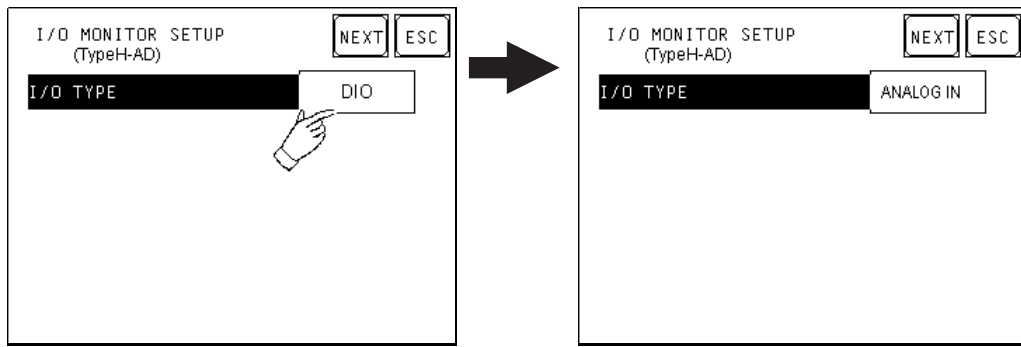

Note:

The setup item — such as the filter time or the output range — for each I/O Type (I to V) is enabled when the I/O units are monitored during the OFFLINE mode.

(I) DIO

You can set up the Standard Input Filter Time and monitor DIO in this screen. In the DIN area, the corresponding bit numbers are displayed in reverse, depending on the ON/OFF status of external data input. In the DOUT area, touching the corresponding bit number will monitor the ON/OFF status of the output.

Reference LT Type H I/O Setting User Manual (sold separately)

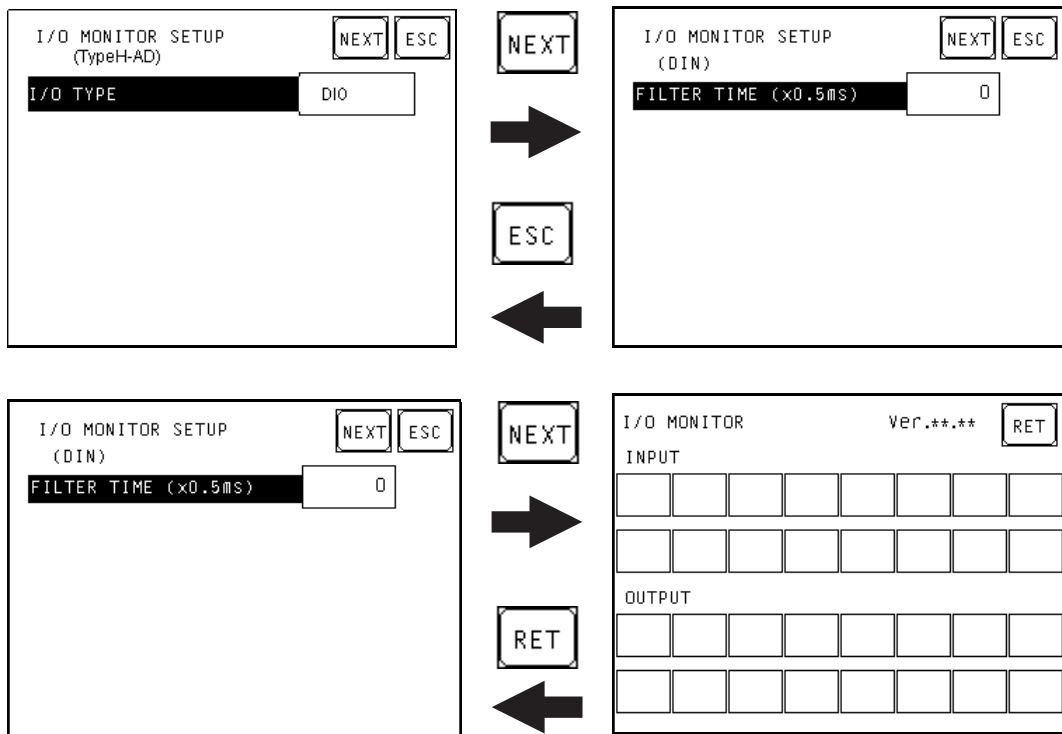

(II) Analog Input

In this I/O setting, you can monitor analog input by setting the input range and the input filter frequency for each channel.

Reference *LT Type H I/O Setting User Manual (sold separately)*

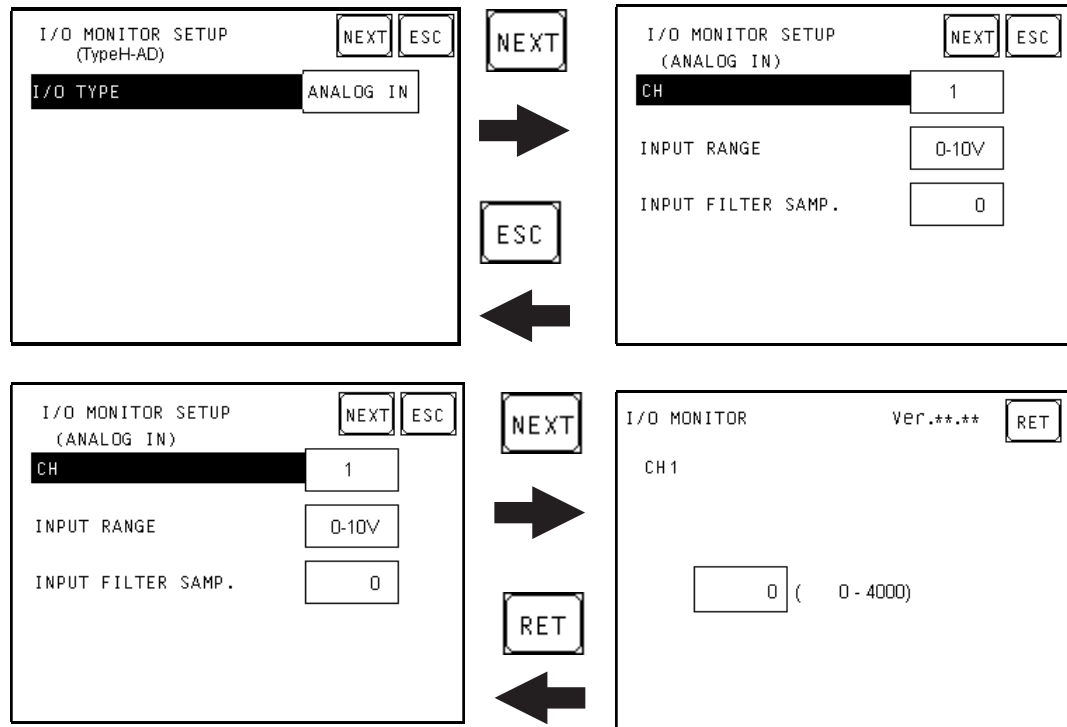

(III) Analog Output

In this I/O setting, analog value is output by setting the output range and the analog output value. Use the up and down arrow keys to set the analog value. When the OUTPUT button is touched, the preset analog value is output.

Reference *LT Type H I/O Setting User Manual (sold separately)*

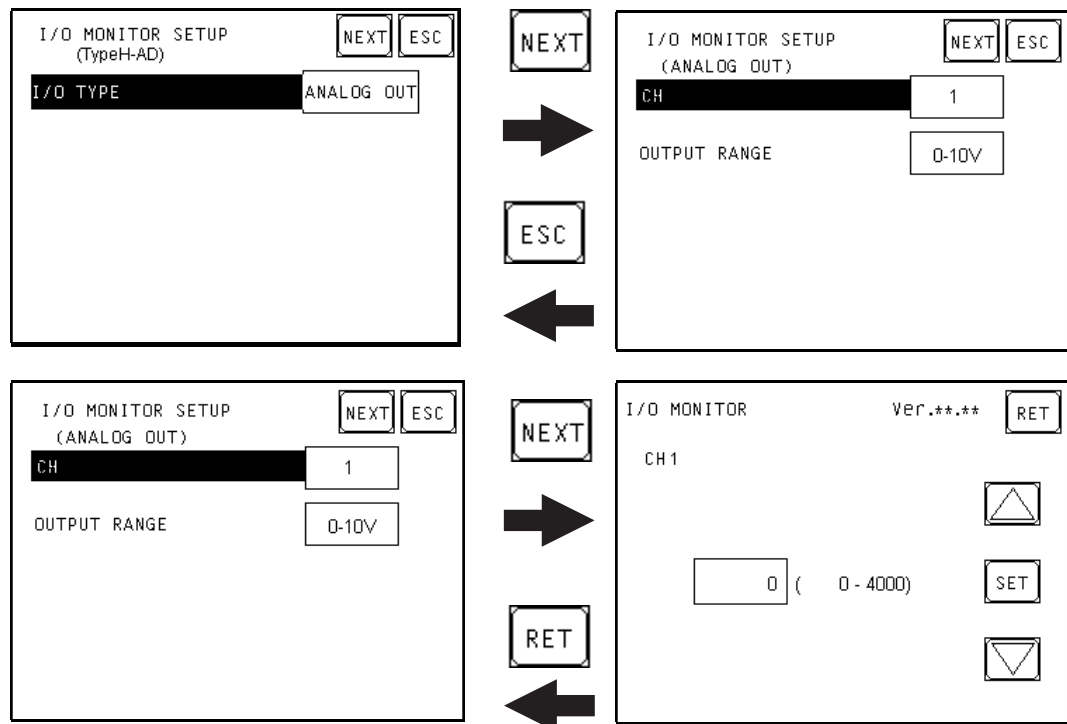

Chapter 6 – Initializing the LT

(IV) Thermocouple Input

In this I/O setting, the Thermocouple Input can be monitored by setting the input range, input filter frequency, and temperature input unit.

Reference *LT Type H I/O Setting User Manual (sold separately)*

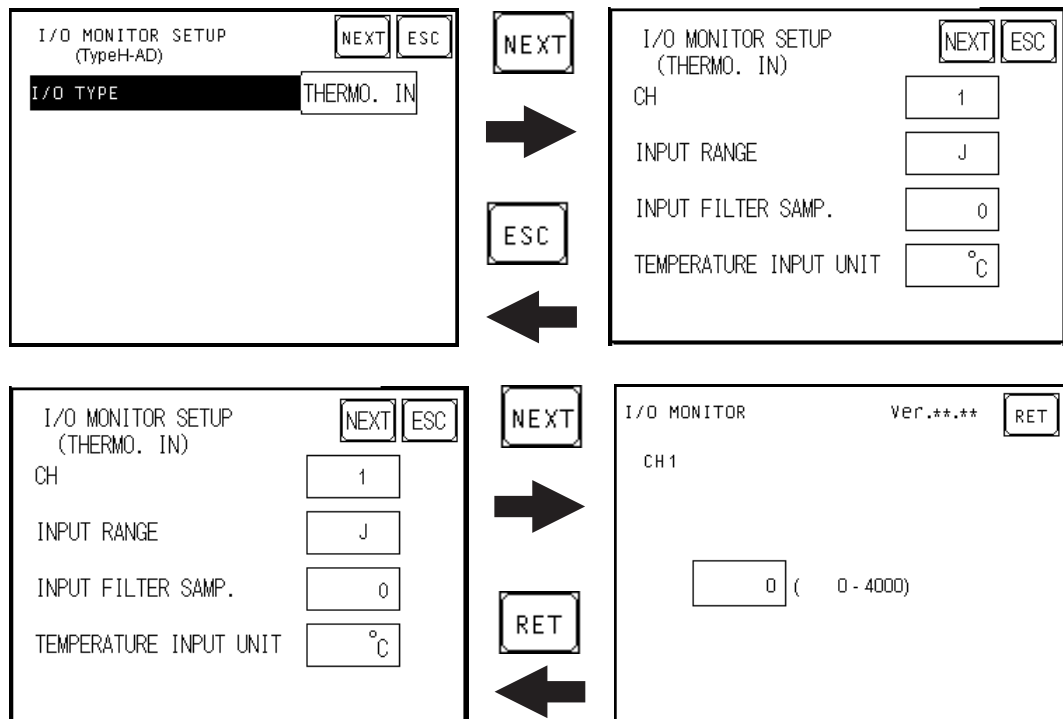

(V) Pt100 Input

In this I/O setting, Pt100 Input can be monitored by setting the input range, input filter frequency, and temperature input unit.

Reference *LT Type H I/O Setting User Manual (sold separately)*

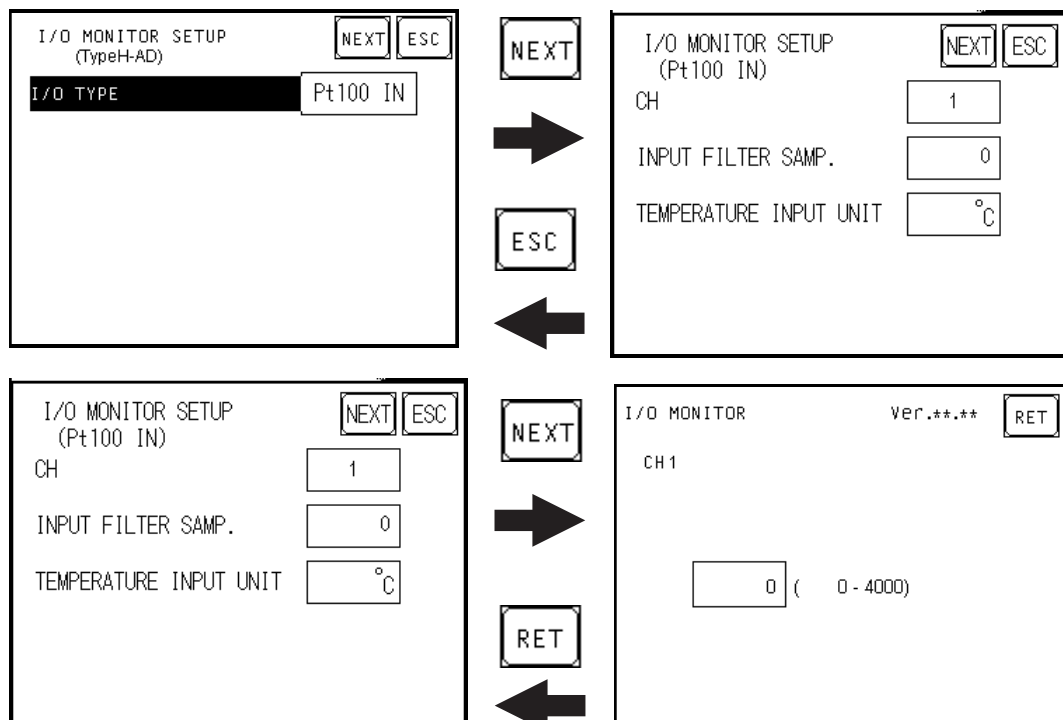

◆ I/O BOARD CHECK

To check I/O board errors, press the SET button. When the I/O Board check starts and no error occurs, OK will display. Return to the previous screen by touching the bottom-left corner and then the bottom-right corner of the screen.

▼Reference▲ *If an error occurs, contact your local LT unit distributor.*

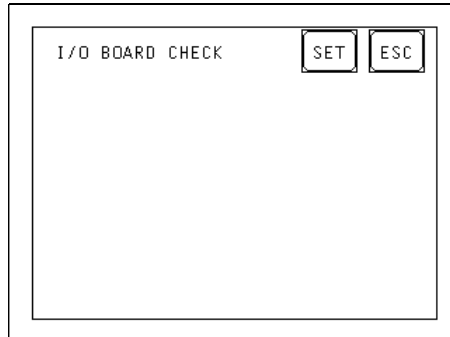

6.6 INITIALIZE INTERNAL MEMORY

This setup screen initializes all LT screen data (internal memory) and Backup SRAM. Initialization does not erase the SYSTEM SET UP, SIO protocol, internal clock settings, logic programs, or the retentive variables.



You cannot cancel the Initialization procedure after pressing [START].

```
INITIALIZE MEMORY [ESC]
WARNING : PREVIOUS DATA WILL
           BE OVERWRITTEN !
ENTER PASSWORD AND PRESS
START KEY ? [ ]
           [START]
```

To initialize the LT unit’s internal memory, enter the default password, “1101,” or the password entered in the SYSTEM SET UP screen.

Reference 5.3 – “INITIALIZATION”



The time required for Initialization is between 10 and 20 seconds.

6.7 SET UP TIME

Set the LT unit’s internal clock in the Set Up Time screen. Adjust the Date and Time display settings in the PRESENT TIME setting item.



The screen displays the Hour and Minute settings, but not the Seconds.

```
SET UP TIME [SET] [ESC]
PRESENT TIME
' Y. M. D. :
TIME SET UP
' [ ] Y. [ ] M. [ ] D. [ ] : [ ]
```

The LT unit’s internal clock has a slight error. At normal operating temperatures and conditions, with the LT operating from its lithium battery, the degree of error is ± 65 seconds per month. Variations in operating conditions and battery life can cause this error to vary from -380 to +90 seconds per month. For systems where this degree of error will be a problem, the user should monitor this error and make adjustments as necessary.

6.8 SET UP SCREEN

Use this screen to enter the number of the screen that is initially displayed after startup, the character size when the LT is in RUN mode, and other general screen items.

SET UP SCREEN		SET	ESC
INITIAL SCREEN NO.	B	1	
ALARM MESSAGE V SIZE		1	
H SIZE		1	
ONLINE ERROR DISPLAY		ON	

INITIAL SCREEN NO.

This setting item specifies the file number of the screen that initially displays on startup.

If the BIN option was selected for DATA TYPE OF SCREEN NO in the SYSTEM SET UP screen, enter a number from B1 to B8999; if BCD was the setup option, enter a number from B1 to B1999.

ALARM MESSAGE

Use this setting item to set the character size for the ALARM MESSAGE, when activated by the Alarm Bulletin.

1

2

4

When using single-byte characters:

V size=1
H size=1
16×8 pixels

V size=2
H size=2
32×16 pixels

V size=4
H size=4
64×32 pixels

When using double-byte characters:

V size=1
H size=1
16×16 pixels

V size=2
H size=2
32×32 pixels

V size=4
H size=4
64×64 pixels

ONLINE ERROR DISPLAY

Use this item to set up whether or not error messages display during RUN mode.

6.9 FONT SETTING

Use this screen to set the font that is displayed by the LT.

FONT SETTING	SET	ESC
FONT SETTING	JAPAN	
KANJI FONT QUALITY	HIGH	

FONT SETTING

Select the font type that is displayed on the LT unit's screen during operation.

KANJI FONT QUALITY

Designates the font display quality for enlarged characters.

Differences in FONT SETTINGS

◆ When FONT SETTING is set to [JAPAN]

Single-byte characters will remain 8x16-dot characters when enlarged.

Double-byte characters are displayed as:

Standard Characters are displayed using 16x16-dot "blocks." When enlarged, this font will remain a 16x16-dot character.

HIGH When enlarged to double size, Level 1 JIS Kanji Code characters display as 32x32-dot characters. Level 2 JIS Kanji Code characters will remain 16x16-dot characters.

HIGH (1, 2) When enlarged to double size, both Level 1 and Level 2 JIS Kanji Code characters display as 32x32-dot characters.

◆ When FONT SETTING is set to any other type, such as [CHINA], [I-ASCII], [KOREA], or [TAIWAN]

Standard Half-size (single-byte) characters display as 16x8-dot characters. Full-size characters, regardless of the display size used, always display as 16x16-dot characters. When enlarged, this font will remain a 16x16-dot character.

Chapter 6 – Initializing the LT

- HIGH (1) All half-size (single-byte) characters — ASCII code: 21h to 7Dh, or alphanumeric characters (except the “ ^ ” and “ ‘ ” characters) — display as high quality characters.
- 16x16-dot characters or larger display as high quality 16x16 fonts.
 - 32x32-dot characters or larger display as high quality 32x32 fonts.
- Full-sized (double-byte) characters display as 16x16-dot characters, and remain 16x16-dot characters when enlarged.
- HIGH (1, 2) All single-byte characters — ASCII code: 21h to 7Dh, or alphanumeric characters (except the “ ^ ” and “ ‘ ” characters) — display as high quality characters.
- When 16x16 dots are used, the characters display as high quality 16x16-dot characters.
 - When 32x32 or larger-sized dots are used, the characters display as high quality 32x32-dot characters.
- Full-sized (double-byte) characters — [KOREA], [TAIWAN], and [CHINA] — display as 32x32-dot characters when enlarged to 32x32-dot characters or larger.

Memo

Chapter

7 RUN Mode and Errors

1. RUN Mode
2. Troubleshooting
3. Self-Diagnosis
4. Error Messages

7.1 RUN Mode

The LT unit enters the RUN mode in two instances: either immediately after plugging in the unit's power cord, or from the LT unit's OFFLINE mode.

7.1.1 After Connecting the Power Cord

The method of LT startup depends on which START TIME setting is specified in the Initialization Settings | SYSTEM SETUP screen.

■ When START TIME is set to "0"

When the LT unit's power cord is connected, the version information screen appears (see image, below). The screen designated by the initialization screen file number (within the Initialization Settings | System Setup screen) appears, and the LT starts to communicate with the connected device.

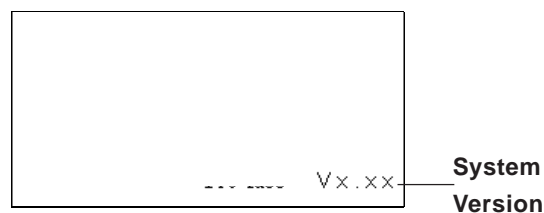

■ When START TIME is set to any value other than "0"

When the LT unit's power cord is connected, a value appears in the version information screen (see below), which counts down the seconds designated by the START TIME setting. The screen designated by the initialization screen file number (within the Initialization Settings | SYSTEM SETUP screen) appears, and the LT starts to communicate with the connected device.

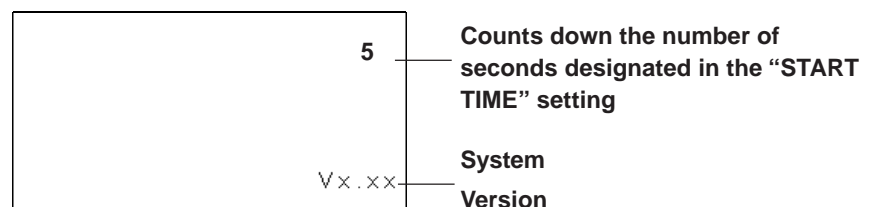

If the initialization screen's file number is not designated, or if a number is designated that does not exist, the version information screen remains displayed.



Note: Depending on the display device's startup time, it is possible that the screens shown above may not be initially displayed.

Chapter 7 – RUN Mode and Errors

7.1.2 Via OFFLINE Mode

Touch the [MAIN MENU]'s RUN option to start your downloaded project.

The [INITIALIZE] menu's [SETUP] screen designates the screen that initially appears in RUN mode. After this first screen appears, communication with the connected device begins.

However, if the initial screen has not been created, or does not exist, the version information screen (see previous page) remains displayed.

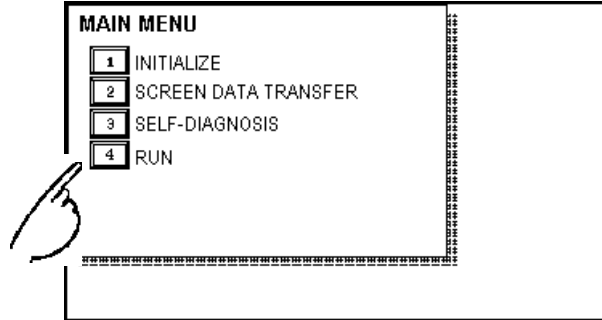

Note:

To enter OFFLINE Mode, touch the top left corner of the LT unit's screen within 10 seconds after connecting the LT unit's power cord.

After powering up the LT, the initial screen appears. This screen is equipped with a built-in (invisible) switch in the top left corner that, if touched within 10 seconds, can change the LT from RUN to OFFLINE mode.

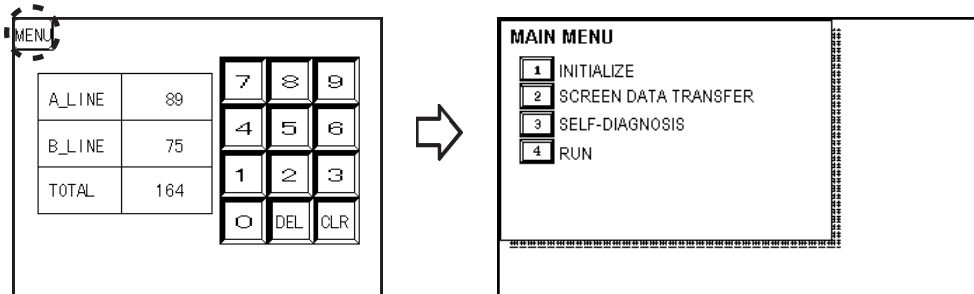

7.2 Troubleshooting

This section describes how to find and resolve problems that may occur with the LT. If there is a problem with the connected device, refer to its corresponding manual.

7.2.1 Possible Problems

The following items are problems that may occur while using this unit.

(A) No Display (Section 7.2.2)

The screen will not display even when the LT unit is powered on. Also, during RUN mode, the screen disappears.

(B) Touch Panel Does Not Respond (Section 7.2.3)

The touch panel does not react when touched, or the reaction time is very slow.

(C) Cannot Execute Logic Program (Section 7.2.4)

The LT freezes, or the control memory's retentive area does not work.

(D) DIO, Analog Input, Analog Output, Temp. Input Troubleshooting (Section 7.2.5)

High-speed Counter Input, Pulse Output/PWM Output, Analog Input, Analog Output, Temperature Input (Thermocouple, Pt100) problems.

(E) Clock Settings Cannot be Entered (Section 7.2.6)

Even after clock settings are entered, the LT unit's clock settings remain eg.00/01/01.

▼Reference▲ For problems A to E, see the corresponding flowcharts and tables on Troubleshooting in Sections 7.2.2 to 7.2.6.

(F) OFFLINE Displays During RUN Mode

The LT unexpectedly goes to the OFFLINE mode while operating, or the LT automatically goes to the OFFLINE mode when the power is turned ON. In this case, a SYSTEM ERROR may have developed while displaying the OFFLINE Mode screen.

▼Reference▲ 7.4.2 – “Error Messages – Details”

If the LT goes to the OFFLINE mode without displaying an error message when the power is turned ON, be sure that no object has touched the screen accidentally. Any object that touches the top-left corner of the screen within 10 seconds after the power turns ON may cause the LT to go OFFLINE.

Chapter 7 – RUN Mode and Errors

7.2.2 No Display

When the screen does not display when powering up, or the screen turns OFF by itself during RUN mode, use the following flowchart to find an appropriate solution.

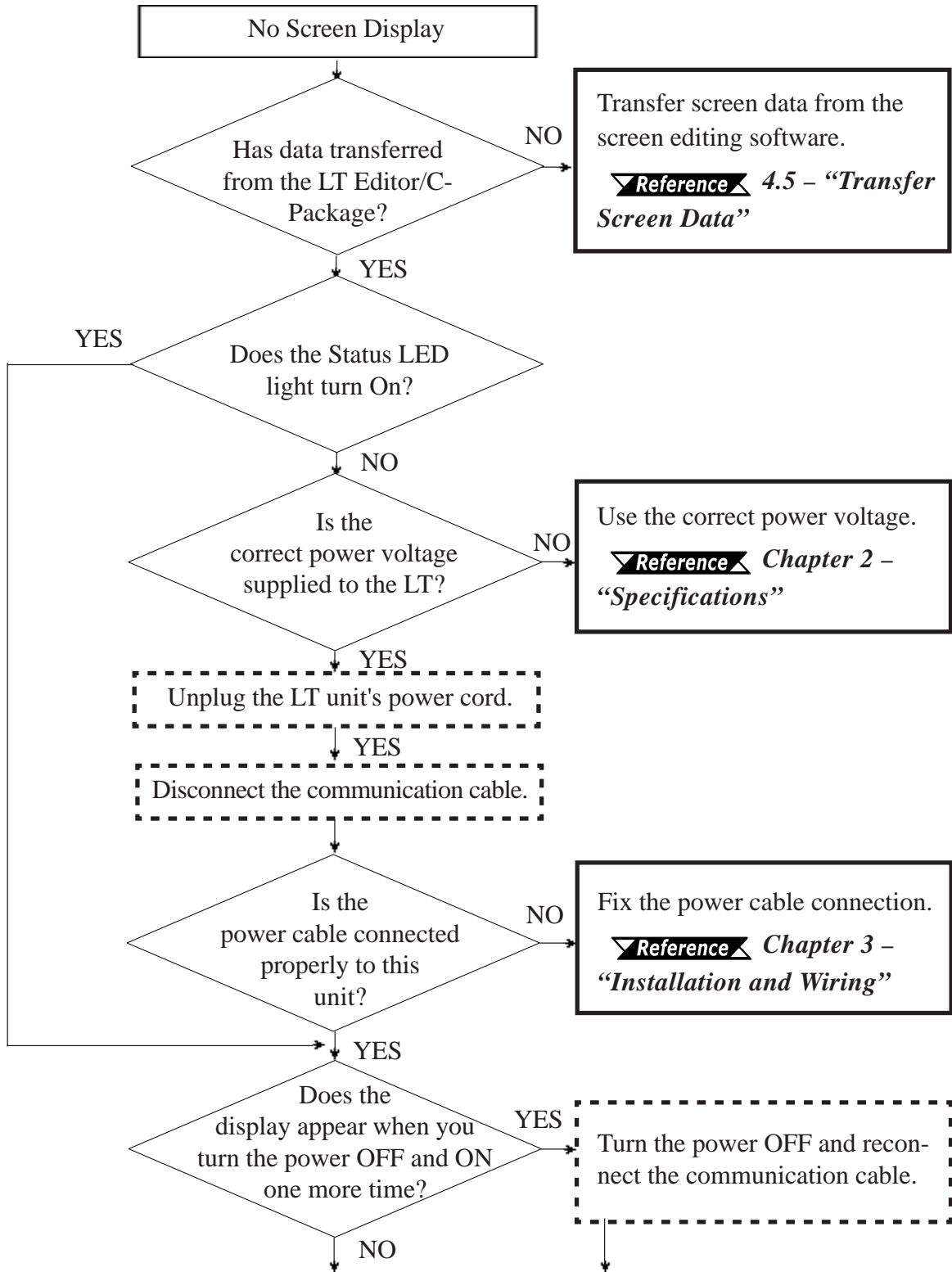

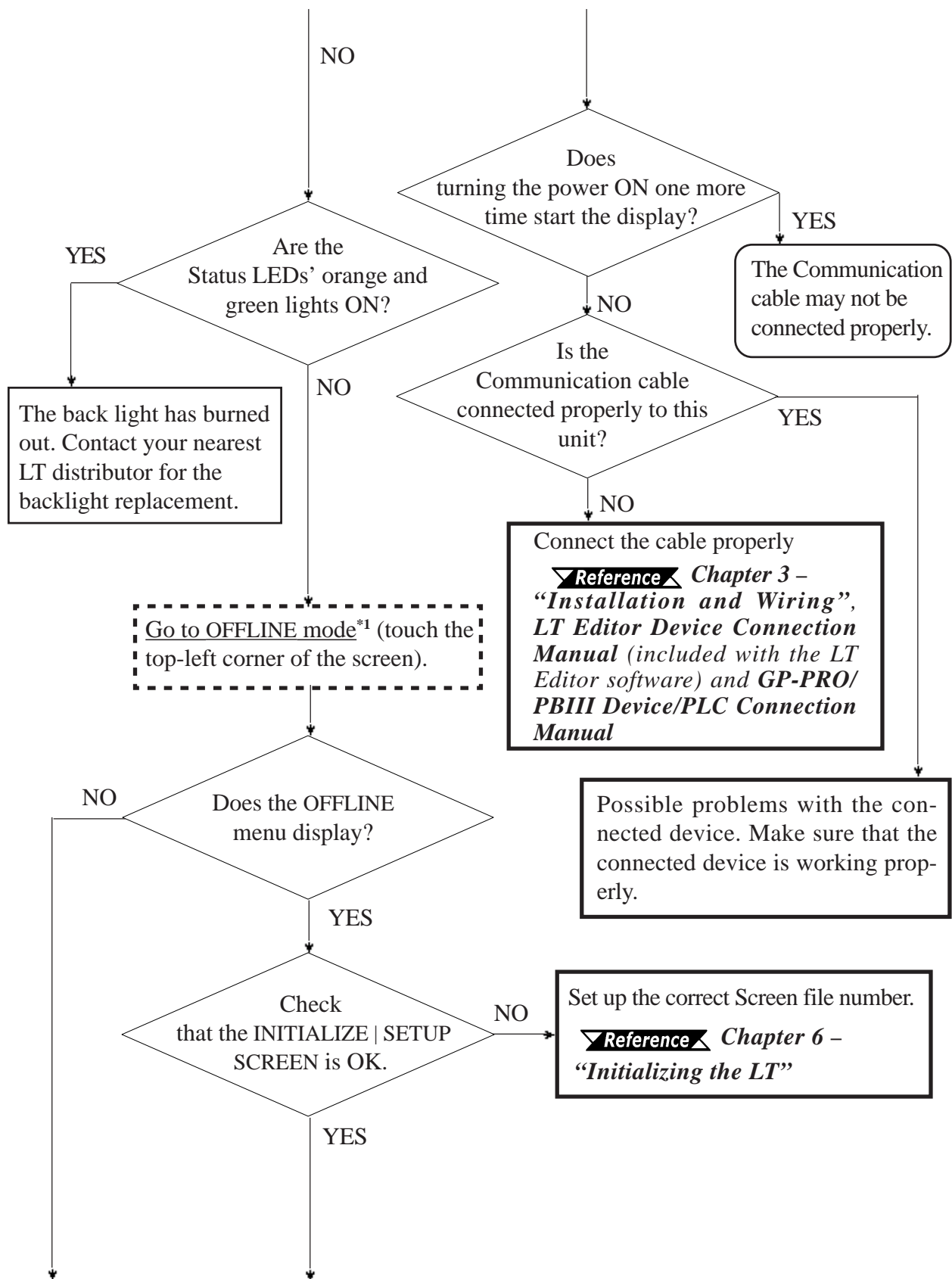

1 To make the OFFLINE screen appear, turn the power OFF, then ON, and then touch the upper-left corner of the screen within 10 seconds.

Chapter 7 – RUN Mode and Errors

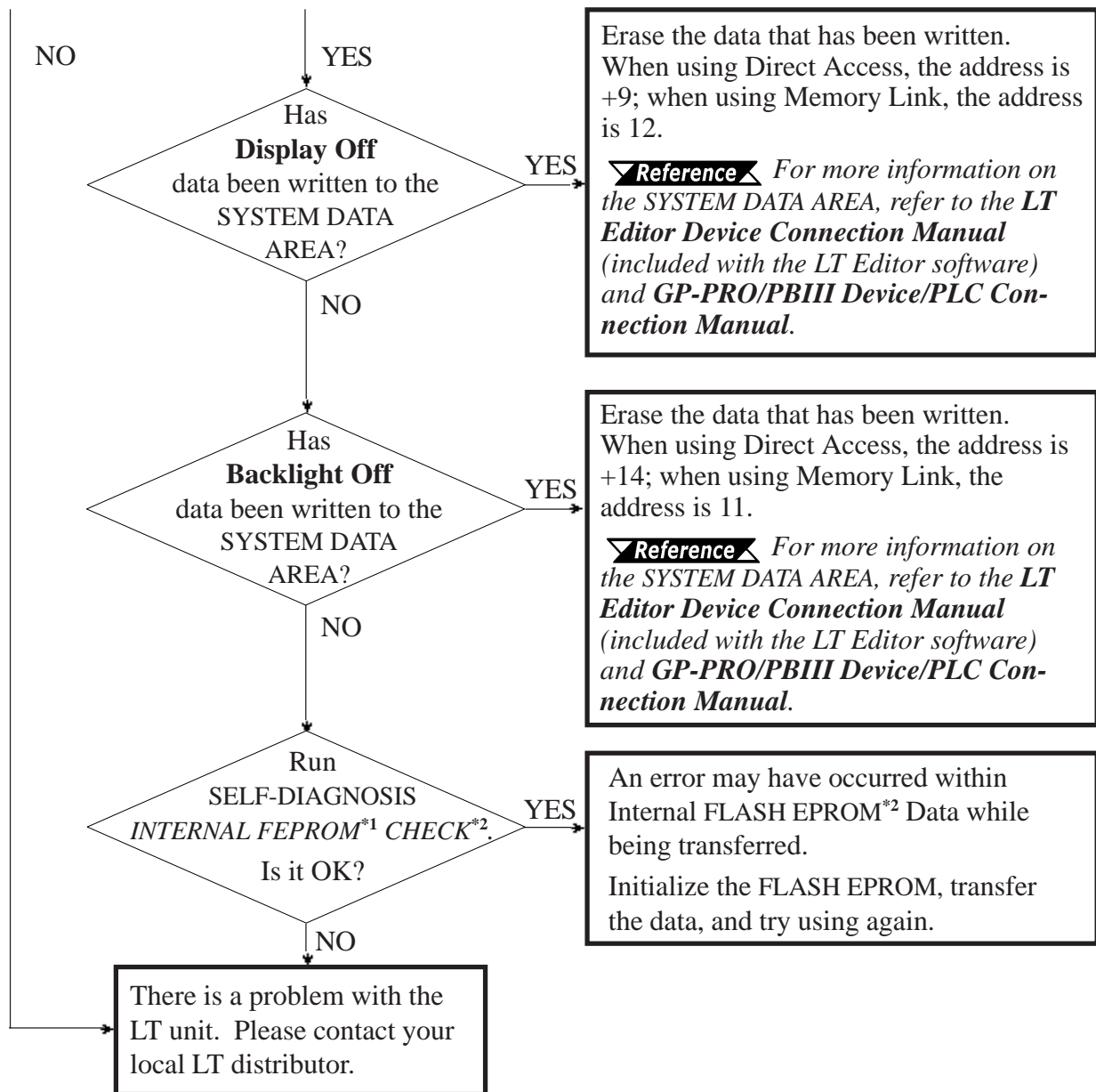

1 Also known as “FEEPROM” (Flash Electronic Erasable Programmable Read Only Memory).

2 When you run the SELF-DIAGNOSIS area’s FLASH EPROM CHECK, all screen data is erased. Therefore, be sure to make a backup of all LT screens prior to performing this check.

7.2.3 Touch Panel Does Not Respond

When the touch panel does not respond, or when its response time is very slow after being touched, use the flowchart below to find the origin of the problem and the appropriate solution.

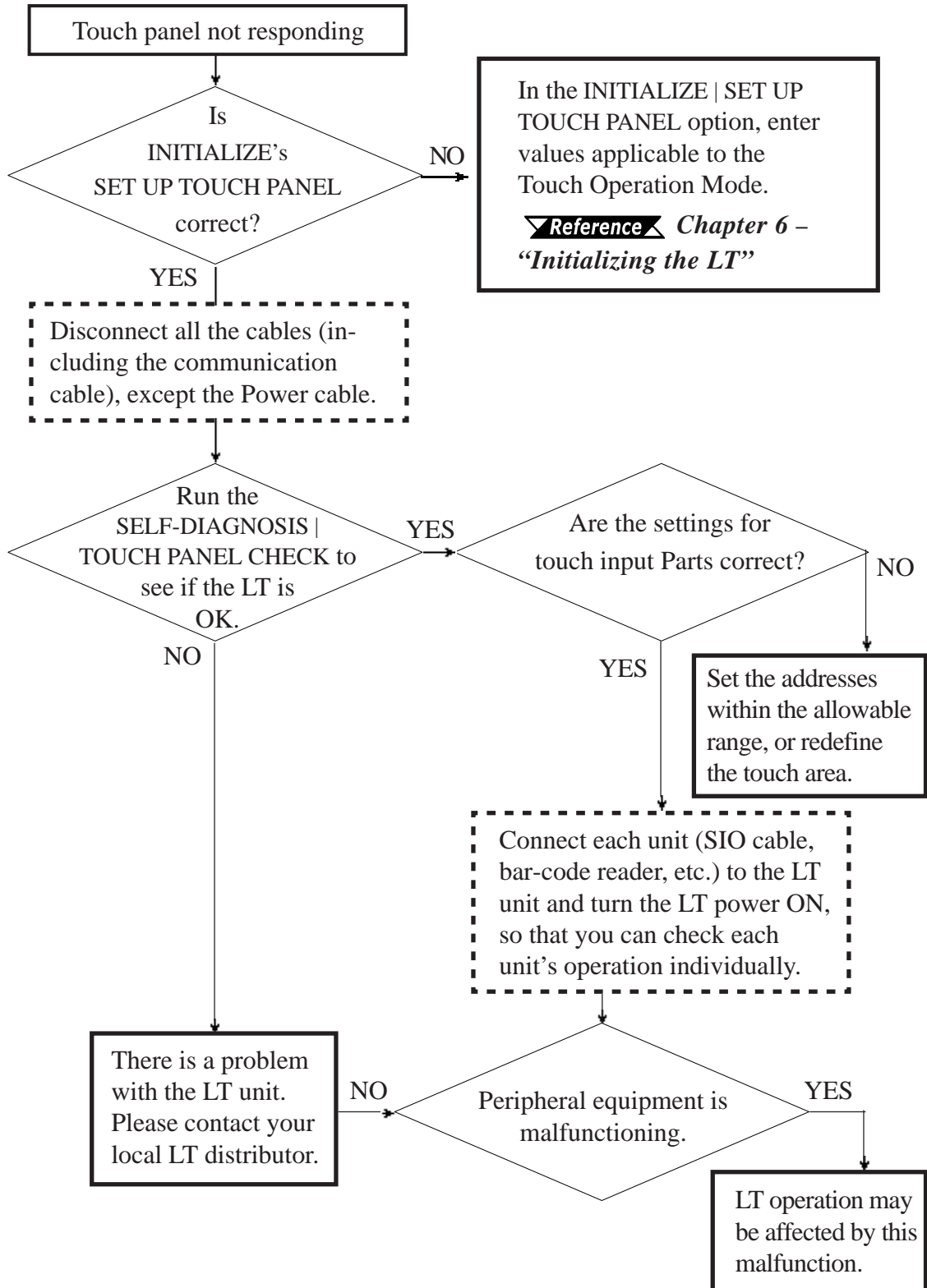

Chapter 7 – RUN Mode and Errors

7.2.4 Cannot Execute Logic Program

Problem	Reason	Solution
Retentive area of control memory does not work	Battery Problem	Change the battery.
	Memory Problem	Change the memory unit.
Program Error	This is a program data transfer error. The data was not (but should have been) transferred from the data hold area to the RUN area.	Use LT Editor/C-Package to restart the control feature. Reference <i>LT Editor Operation Manual – Logic Program</i> (included with the LT Editor software) and <i>Pro-Control Editor Operation Manual</i> .
	When RUN/STOP switchover is performed, the Hold CLEAR feature is enabled.	Turn this feature OFF.
After changing to RUN mode, control returns to STOP mode	Either a command performance alarm error has occurred, or a major error has occurred.	Debug the program. Check the System variable "#FaultCode."

7.2.5 DIO, Analog Input, Analog Output, Temp. Input Troubleshooting

■ High-speed Counter Input

Problem	Reason	Solution
Does not perform Count operation	Does the LT display an error?	If the LT unit displays an error, use the Troubleshooting section of the corresponding LT manual to set the LT unit to normal operation.
	Are CT0 to CT3 wired correctly?	Check and fix external wiring. (Terminals CT0 to CT3 are dedicated to the counter.)
	Apply voltage directly to the pulse input terminals (CT0 to CT3).	If the unit does not perform count operation, check and fix the pulse generator and/or the external wiring.
	Is the group setting correct?	Check the terminal assignment display to see if the input settings are correct.
	Does #IOStatus display an error code?	If #IOStatus[1] is not 0, refer to the countermeasures provided in the I/O Setting User Manual or Online Help.
Count value is not normal.	Is the maximum speed of input pulses less than 10kHz?	Set input pulses to less than 10kHz
	Does the pulse shape entered match performance specifications?	Check pulse shape with a synchroscope. If it does not match specifications, enter the correct pulse shape.
	Do the input wires use a twist pair shield cable? Is the shield line grounded?	<ul style="list-style-type: none"> • Use a twist pair shield cable for input wires. If the shield line is not grounded, ground it. • Shorten the encoder cable as much as possible.
	Are the insides of the panel and surrounding units protected from noise?	Protect from noise.
	Is there enough distance between high voltage units and the pulse input line?	Use an independent line for pulse input wires. The pulse input line and the power line should be separated by no less than 15cm.
	Are the count input values that are entered in CT0 to CT3 the same?	When the count values are different, a hardware error exists. Please contact your local distributor.
	Is the counting method setting correct when the single phase input is used?	Set a correct counting method (Up counter, Down counter).
	Does #IOStatus display an error code?	If #IOStatus[1] is not 0, refer to the countermeasures provided in the I/O Setting User Manual or Online Help.

Chapter 7 – RUN Mode and Errors

■ Pulse Output/PWM Output

Problem	Reason	Solution
Does not produce pulses	Does the LT display an error?	If the LT unit displays an error, use the troubleshooting section of the corresponding LT manual to set the LT unit to normal operation.
	Are PLS0 to PLS3 wired correctly?	Check and fix external wiring (Terminals PLS0 to PLS3 are dedicated to pulse output.)
	Is the group setting correct?	Check the terminal assignment display to see if the input settings are correct.
	Does #IOStatus display an error code?	If #IOStatus[1] is not 0, refer to the countermeasures provided in the I/O Setting User Manual or Online Help.
Load (such as motor) operates, but not normally.	Is it affected by noise?	<ul style="list-style-type: none"> • Minimize the number of connections (i.e., terminals and connectors) along the wire. • Keep AC circuit wires as far as possible from pulse signal wires. • Install in a covered steel cabinet to protect from ambient noise, magnetic fields, and inductive power. • Wire for minimum distance between the LT and the amplifier.
	Do the output wires use a twist pair shield cable? Is the shield line grounded?	Use a twist pair shield cable for output wires. If the shield line is not grounded, ground it.
	Are the insides of the panel and surrounding units protected from noise?	Protect from noise.
	Does the total pulse output exceed 5kHz?	Set the total of pulse output of PLS0 to PLS3 to less than 5kHz.
	Does the PWM output exceed 2.5kHz?	Set the channel output of PWM (PWM0 to PWM3) to less than 2.5kHz.
	Does #IOStatus display an error code?	If #IOStatus[1] is not 0, refer to the countermeasures provided in the I/O Setting User Manual or Online Help.

■ Analog Input

Problem	Reason	Solution
Data is not updated, even though analog values are entered.	Does the LT display an error?	If the LT unit displays an error, use the troubleshooting section of the corresponding LT manual to set the LT unit to normal operation.
	Is power supply for analog normal?	Supply DC24V.
	Is it wired correctly?	Check and fix external wiring.
	Does #IOStatus display an error code?	If #IOStatus[1] is not 0, refer to the countermeasures provided in the I/O Setting User Manual or Online Help.
Does not register normal voltage values (current values), although values have been input	Is it affected by noise?	<ul style="list-style-type: none"> • Use a twist pair shield cable for input wires. If the shield line is not grounded, ground it. • Minimize the number of connections (i.e., terminals and connectors) along the wire. • Keep AC circuit wires as far as possible from analog input wires. • Install in a covered steel cabinet to protect from ambient noise, magnetic fields, and inductive power. • Increase the input filter frequency
	Is the input setting correct?	Set input voltage to 0V to 10V. Set current input to 0mA to 20mA.
	When using current input, are AI*_JP and AI*+ connected?	When using current input, connect AI*_JP and AI*+.
	When using voltage input, are AI*_JP and AI*+ open circuit?	When using voltage input, keep AI*_JP and AI*+ open (do not connect).
	Are the insides of the panel and surrounding units protected from noise?	Protect from noise.
	Does #IOStatus display an error code?	If #IOStatus[1] is not 0, refer to the countermeasures provided in the I/O Setting User Manual or Online Help.

Chapter 7 – RUN Mode and Errors

■ Analog Output

Problem	Reason	Solution
No analog output	Does the LT display an error?	If the LT unit displays an error, use the troubleshooting section of the corresponding LT manual to set the LT unit to normal operation.
	Is power supply for analog normal?	Supply DC24V.
	Is it wired correctly?	Check and fix external wiring.
	Does #IOStatus display an error code?	If #IOStatus[1] is not 0, refer to the countermeasures provided in the I/O Setting User Manual or Online Help.
Does not register normal voltage values (current values), although values have been output	Is it affected by noise?	<ul style="list-style-type: none"> • Use a twist pair shield cable for output wires. If the shield line is not grounded, ground it. • Minimize the number of connections (i.e., terminals and connectors) along the wire. • Keep AC circuit wires as far as possible from analog output wires. • Install in a covered steel cabinet to protect from ambient noise, magnetic fields, and inductive power.
	Are the insides of the panel and surrounding units protected from noise?	Protect from noise.
	Is the output setting correct?	Set output voltage to 0V to 10V. Set output current to 0mA to 20mA.
	Does #IOStatus display an error code?	If #IOStatus[1] is not 0, refer to the countermeasures provided in the I/O Setting User Manual or Online Help.

■ Temperature Input (Thermocouple, Pt100)

Problem	Reason	Solution
Data is not updated even though temperature is input.	Does the LT display an error?	If the LT unit displays an error, use the troubleshooting section of the corresponding LT manual to set the LT unit to normal operation.
	Is power supply for analog normal?	Supply DC24V.
	Is H7FFF displayed?	Wire is disconnected. Check and fix external wiring.
	Does #IOStatus display an error code?	If #IOStatus[1] is not 0, refer to the countermeasures provided in the I/O Setting User Manual or Online Help.

Chapter 7 – RUN Mode and Errors

■ Temperature Input (Thermocouple, Pt100), cont.

Problem	Reason	Solution
Does not enter normal values, although values have been input	Is it affected by noise?	<ul style="list-style-type: none"> Minimize the number of connections (e.g., terminals and connectors) along the wire. Keep as much distance as possible between AC circuits and the Pt100 or the thermocouple. Install in a covered steel cabinet to protect from ambient noise, magnetic fields, and inductive power. Use compensating conductors that are as short as possible. Increase the input filter frequency
	Is the temperature input range appropriate? Is H7FFF (exceeding the upper limit) or H8000 (exceeding the lower limit) displayed?	Set the temperature input ranges as follows: <ul style="list-style-type: none"> Pt100: -50°C to 400°C Thermocouple (J Type): -100°C to 700°C Thermocouple (K Type): -100°C to 1200°C
	Are temperature unit settings for Celcius (°C) and Farenheit (°F) correct?	Set the correct temperature input unit.
	When using Pt100:	
	• Are you using a 3-wire type platinum resistance temperature sensor?	Use Pt100 connection in 3-wire method.
	When using thermocouple:	
	• Are you using a thermocouple or a compensating conductor that is compatible with the type (J or K) you are using?	Use the thermocouple or compensating conductors that are compatible with the type (J or K) you are using.
	• Does the input range setting match that of the thermocouple type (J or K) setting?	Set the input range to match that of the thermocouple type (J or K) you are using.
	Are the + and - connections reversed on the thermocouple or compensating conductors?	Connect + and - correctly.
	Are the insides of the panel and surrounding units protected from noise?	Protect from noise.
Does #IOStatus display an error code?	If #IOStatus[1] is not 0, refer to the countermeasures provided in the I/O Setting User Manual or Online Help.	

Chapter 7 – RUN Mode and Errors

7.2.6 Clock Settings Cannot be Entered

This problem occurs when the lithium backup battery's voltage, used for the internal clock, runs out. To enter the clock settings, please read the CLOCK SETUP ERROR directions.

▼**Reference**▲ *7.4.2 Error Messages - Details* ■ **CLOCK SETUP ERROR**

7.2.7 Error Screens

If the following error screen appears when you start the LT, it indicates an error has occurred and the LT is not set up correctly. Be sure to perform screen transfer (Force System Setup) again.

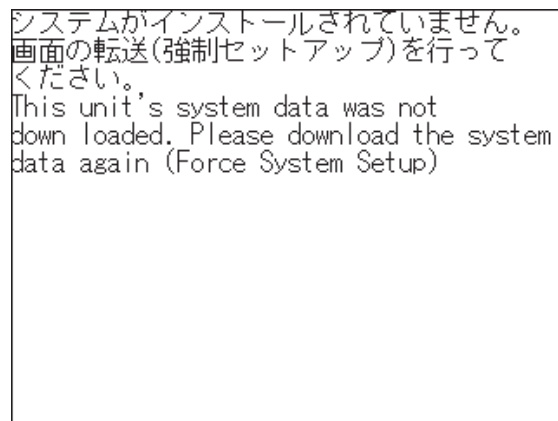

7.3 SELF-DIAGNOSIS

The LT unit is equipped with a number of self-diagnosis features used to check its system and interfaces for any problems.

7.3.1 SELF-DIAGNOSIS ITEM LIST

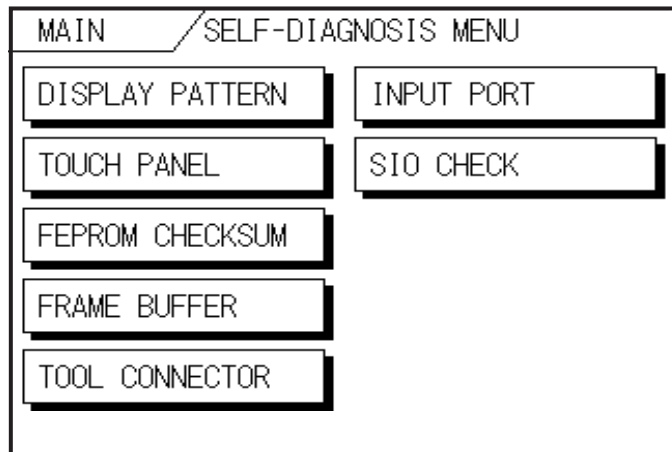

- **DISPLAY PATTERN**
Checks all the figures and tiling patterns.
- **TOUCH PANEL**
Checks each LT touch panel square.
- **FEPRM CHECKSUM**
Checks the System and Protocol of the LT Internal Memory (FEPRM).
- **FRAME BUFFER**
Checks the internal display memory (Frame Buffer)
- **TOOL CONNECTOR^{*1}**
Checks the Tool Connector control lines and send/receive lines.
- **INPUT PORT**
Checks the Input Port (for maintenance by Pro-face only).
- **SIO CHECK**
This setting is not available.

Chapter 7 – RUN Mode and Errors

7.3.2 SELF-DIAGNOSIS - Details

This section explains the contents of [SELF-DIAGNOSIS].

Reference For information on how to set up the menu interface, see **Chapter 5 – “OFFLINE Mode.”**

For information on how to set up the Special Tools, see **Chapter 3 – “Installation and Wiring.”**

■ DISPLAY PATTERN

Used to check the drawing function when the buzzer does not sound and when the device contents do not display correctly. Checks are performed on the various screen pattern displays (8 screens), the ON/OFF Display, and the KANJIROM CHECKSUM. When the ON/OFF Display is checked, the Buzzer ON/OFF check is run simultaneously. If KANJIROM CHECKSUM is normal, **OK** displays. If there is a problem, **NG** displays.

■ TOUCH PANEL

Touch Panel check. Checks if each touch cell lights up when touched.

■ INTERNAL FEPRM CHECKSUM (Display Area)

The Internal FEPRM system and Protocol check searches for any problems that may occur during operation. When running the check, the screen changes as follows:

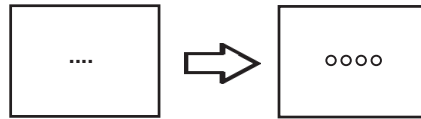

When the FEPRM is normal, **OK** displays. If there is a problem, the screen stops in the middle of operation. This check does not erase the System or Protocol.

■ FRAME BUFFER

The Frame Buffer Check (display memory) looks for any display problems that may develop. When everything is normal, **OK** displays. When there is a problem, an error message displays.

Chapter 7 – RUN Mode and Errors

■ TOOL CONNECTOR

Use the Tool Connector Control line and the Send/Receive line check when the LT cannot send and receive data from the PC. To run the check, it is necessary to connect the pin-side of the Tool Connector Check Loop Back Cable (Dsub9pin) to the LT unit's Downloading Cable (provided in the software package).

When everything is normal, **OK** displays. When there is a problem, an error message displays.

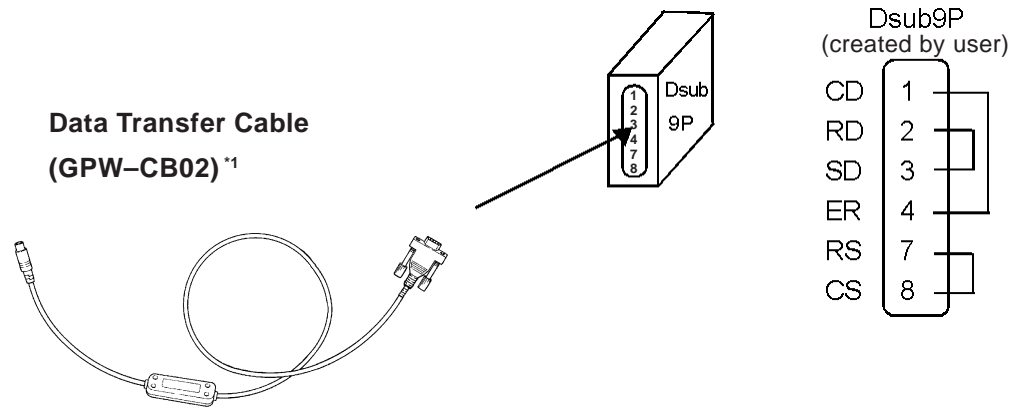

This check cannot be performed using the USB Data Transfer Cable (GPW-CB03).

■ INPUT PORT

Used for Pro-face maintenance checks only.

Chapter 7 – RUN Mode and Errors

7.3.3 CONTROLLER SELF-DIAGNOSIS

The LT Editor/C-Package or LT controller setting data is written to non-resident memory. Each of the setting items below is assigned a default value, but if necessary, be sure that your own settings are entered.

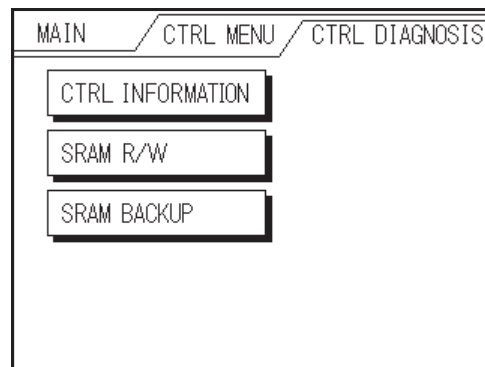
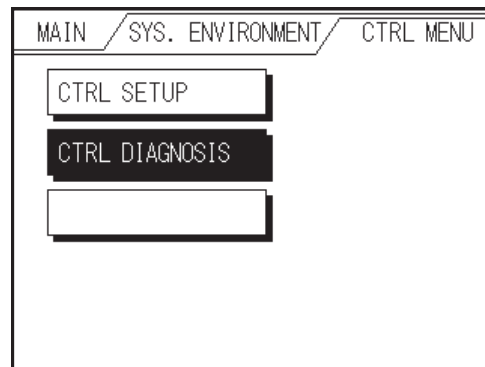

■ CONTROLLER DATA

Shows the current controller version data.



Performing the checks listed below will delete all resident SRAM data.

■ SRAM R/W

Performs an SRAM R/W (Read/Write) check. Writes the data required to perform the backup SRAM check.

■ SRAM BACKUP

Before performing this check, be sure to perform the above SRAM R/W check. Then, after turning the LT unit's power OFF and then ON, perform the SRAM BACKUP check.

7.4 Error Messages

This section explains the messages that appear when an error has occurred in the LT unit during RUN mode. The problem causing the error message and its related countermeasure are explained in the table below.

After a problem has been solved, unplug the LT unit's power cord and then reattach it. *(Only the latest error message will appear on the LT unit's screen.)*

7.4.1 Error Message List

Error Message	Problem	Countermeasure
SYSTEM ERROR (03 : **)	During screen data transfer, an unrecoverable error occurred.	Reference 7.4.2 – "Error Message Details"
SYSTEM ERROR (*** : *** . ***)	During screen data transfer, an unrecoverable error occurred.	Reference 7.4.2 – "Error Message Details"
ILLEGAL ADDRESS IN SCREEN DATA (00B.***.***)	Settings that overlap addresses are being used.	Set the addresses correctly after checking the screen data.
UNSUPPORTED TAG IN SCREEN DATA	The LT currently in use does not support the desired feature.	Set the feature correctly after checking the screen data.
SCREEN MEMORY DATA IS CORRUPT (nnnn:mmmm)	Screen data is corrupted: <ul style="list-style-type: none"> • nnnn indicates the Screen Number that identifies the location of the error. • mmmm indicates the number of screens that have errors. (Decimal) 	Check the screens that have errors, correct all errors, and then transfer the screen data again.
CLOCK SETUP ERROR	The backup battery for the internal clock is running low.	Reference 7.4.2 – "Error Message Details"
SCREEN TRANSFER ERROR	Indicates an error that has occurred in data transmission from the screen editor to the LT panel.	Re-transfer the screen data.
SCREEN TAG LIMIT EXCEEDED	Number of T ags exceeds the 385 T ag limit maximum.	Reference 7.4.2 – "Error Message Details"

Chapter 7 – RUN Mode and Errors

7.4.2 Error Messages - Details

■ SYSTEM ERRORS

Indicates a fault in the basic operations of the LT.

The error code is listed at the end of the error message (see below). Report the error code number and details about the error's occurrence to your local LT distributor.

◆ SYSTEM ERROR (03 : x x)

An unrecoverable error occurred during screen data transfer.

03 : x x

Error No. _____
Constant Value _____

◆ SYSTEM ERROR (x x x : x x x : x x x)

An unrecoverable error occurred during screen data transfer.

x x x : x x x : x x x

Error No. 1 _____
Error No. 2 _____
Error No. 3 _____

Possible Solutions

- Make sure that the LT unit's power cord and Input signal line have been separately wired.
- Make sure that the FG line has been grounded correctly, according to your country's standards.
- Re-send the screen data from the PC to the LT.
- If other types of communication errors, such as [RECEIVE DATA ERROR] or [PLC COM. ERROR], have occurred, try also to correct these problems.

▼ **Reference** ▲ 7.4.1 – “Error Message List”

If the above-mentioned methods do not solve the problem, please contact your local LT distributor.

◆ When the LT Changes to OFFLINE Mode during RUN Mode

When the LT changes to OFFLINE mode without the user first touching the screen, the screen data may be damaged.

Approximately 10 seconds after the SYSTEM ERROR message displays, the screen automatically reverts to OFFLINE mode. Run the INITIALIZE MEMORY command and transfer the LT screen data again from your PC.

In most cases, system errors are related to the problems described below.

Environment-Related Problems

If an error's occurrence has no apparent relation to the LT unit's current operation, the condition of the LT unit's operating environment may be the cause. These conditions can include noise or electrostatic interference in the power cord or the communication line. Make sure that the power cord and communication line wiring, and the FG grounding are correct.

Screen or Project Data-Related Problems



If an error seems to be caused by a particular LT operation, the error may be related to the screen or project data transferred to the LT. Try to send the screen data via the FORCE SYSTEM SETUP feature, which then transfers both the screen data and the project data to the LT.

LT-Related Problems

If disconnecting and then reconnecting the power cord corrects an error, the problem may not be related to the LT unit itself. To identify any problems with the LT unit, run the OFFLINE mode's SELF-DIAGNOSIS program.

Continuously-Occurring Communication Errors (using Direct Access)

If the LT defines a communication error that occurs continuously as a system error, you need to solve the problem that originally caused the communication error.

Chapter 7 – RUN Mode and Errors

■ ILLEGAL ADDRESS IN SCREEN DATA

Caused by an overlap of addresses.

The error code is listed at the end of the error message (see below). If the error cannot be corrected, please report the error code and details about the error's occurrence to your local LT distributor.

ILLEGAL ADDRESS IN SCREEN AREA (00B : XXX : XXX)

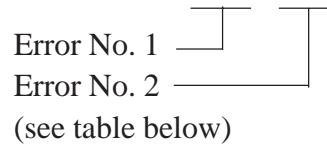

Reference *If the above-mentioned methods do not solve the problem, please contact your local LT distributor.*

Illegal Addresses

Error 1	Error 2	Meaning
0C2	194	The Trend Graph's address is duplicated in the Alarm Message's address setting.
	195	
	196	
0C3	197	The Alarm Message's address is duplicated in the Trend Graph's address setting.
	198	
	199	



Note:

In addition to the above errors, other errors (such as Address Out of Range) can also produce an Illegal Address Error.

■ CLOCK SETUP ERROR

This message displays when the power level of the lithium backup battery (the battery used for the internal clock) is running low. To reset the error, you need to turn the LT unit's power OFF and then ON again. Let the LT run continuously for 24 hours to sufficiently charge the battery for backup, and for approximately 96 hours to fully charge the battery.

If the battery is incorrectly replaced, it may explode. To reduce the risk of danger, do NOT replace the battery yourself. When the battery needs replacing, please contact your local LT distributor.

After changing the backup battery, set up the internal clock.

Reference *Chapter 6 – “Initializing the LT”*



Note:

The lifetime of the backup battery depends on the ambient temperature and the amount of current being charged and used. The table below gives a general indication of how long the battery will last.

Battery Temperature	40° C or lower	50° C or lower	60° C or lower
Expected Lifetime	10 years or longer	4.1 years or longer	1.5 years or longer

■ SCREEN TAG LIMIT EXCEEDED (max. 384 Tags)

When the number of Parts exceeds the 384-Tag limit, any extra Tags are disabled, and the load screen operation is disabled when you try to load screens, beginning with the screen you loaded last.

Reference *To correct this problem, reduce the number of Tags to within the allowed limit.*

Memo

Chapter 8

Maintenance

1. Regular Cleaning
2. Periodic Check Points
3. Changing the Backlight

8.1 Regular Cleaning

8.1.1 Cleaning the Display

When the surface or the frame of the display gets dirty, soak a soft cloth in water with a neutral detergent, wring the cloth tightly, and wipe the display.



- Do not use paint thinner, organic solvents, or strong acid compounds to clean the LT unit.
- Do not use hard or pointed objects to operate the touch-screen panel, since they can damage the panel's surface.

8.1.2 Installation Gasket Check / Replacement

The installation gasket protects the LT and improves its water resistance.

Reference Chapter 3 – Installation and Wiring



If a LT unit is removed from its installation panel and then installed again with an installation gasket that has been used for a long time, it will lose its IP65f equivalent level of protection. Be sure to change the gasket at least once a year, or when scratches or dirt become visible.

■ Installation Gasket Attachment Procedure

1. Place the LT on a level surface with the display panel facing downwards.
2. Remove the gasket from the LT.
3. Insert the new water-resistant gasket. Make sure that the grooved sides face the top and bottom.
4. Confirm that the water-resistant gasket is correctly installed.

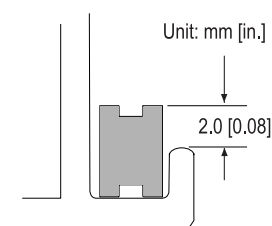
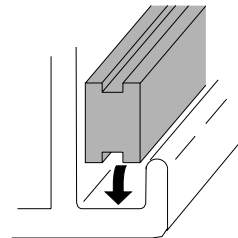



-
- If the water-resistant gasket is not properly inserted into the groove, the gasket's moisture resistance may not be equivalent to IP65f.
 - When the water-resistant gasket is properly installed, approximately 2.0 mm of it will extend outside the groove. Before mounting the LT to the panel, be sure to confirm that the gasket is correctly installed.
-

8.2 Periodic Check Points

To keep your LT unit in its best condition, inspect the following points periodically.

LT Operation Environment

- Is the operating temperature within the allowable range (0°C to 50°C)?
- Is the operating humidity within the specified range (10% RH to 90% RH)?
- Is the operating atmosphere free of corrosive gases?

Electrical Specifications

- Is the input voltage appropriate (DC 20.4V to DC 28.8V)?

Related Items

- Are all power cords and cables properly connected? Have any cords or cables become loose?
- Are all mounting brackets holding the unit securely?
- Are there many scratches or is there much dirt on the installation gasket?

8.3 Replacing the Backlight

The LT unit's backlight should NOT be replaced by the user.

Although the LT is equipped with a long-life, cold-cathode tube backlight, the backlight will eventually need to be replaced.

Monochrome model: 25,000 hours (Approximately 2.8 years)

Color model: 36,000 hours (Approximately 4.1 years)

“Service life” refers to the period after which the brightness decreases to about half the brightness of a new product — assuming continuous (24 hour/day) illumination at normal temperature.

Reference For backlight replacement, please contact your local LT distributor.