



## DANGERS

### *When Designing your LT System:*

- Be sure to design your LT control system so that in the event of a main power supply failure or a LT accident, this system's overall safety integrity will be maintained. If this is not done, incorrect output signals or a LT malfunction may cause an accident.
  - (1) Interlock circuits, etc. designed to interrupt or oppose normal machine movement (i.e. Emergency Stop, General Protection, forward and reverse rotation, etc.), as well as those designed to prevent machine damage (i.e. for upper, lower and traverse movement limit positioning, etc.) should all be designed to be located outside of the LT.
  - (2) Whenever the LT generates a "Watchdog Timer Error", LT operation will halt. Also, when an error occurs in Input/Output control areas that the LT cannot detect, it is possible for unexpected equipment operation to occur there. As a result, to prevent unsafe or unexpected equipment operation, a "Failsafe Circuit" should be created which is completely external to the LT.
  - (3) If an external unit's relay or transistor malfunctions, causing an output (coil) to remain either ON or OFF, a major accident can occur. To prevent this, be sure to set up external watchdog circuits that will monitor vital output signals.
- Be sure to design a circuit that will supply power to the LT's I/O unit(s) before starting up the LT. If the LT's internal program enters RUN mode prior to the I/O unit's load control power turning ON, an incorrect output (signal) or malfunction could cause an accident to occur.
- Be sure to design a program that will ensure the safety of your system in the event of a LT display or control unit malfunction, or in the event of either a data transmission error or power failure between the LogiTouch and any connected unit(s). These types of problems can lead to an incorrect output (signal) or malfunction, which could thereby cause an accident to occur.
- Do not create touch panel switches which could possibly endanger the safety of humans or equipment. This is due to the possibility of a malfunction in the LT or its cable(s), causing the output of a signal that could result in a major accident. All of a system's major, safety-related switches should be designated to be operated separately from the LT.
- Be sure to design your system so that equipment will not malfunction due to a communication fault between the LT and its host controller. This is to prevent any possibility of bodily injury or material damage.
- Do not use the LT with aircraft control devices or medical life support equipment, central trunk data transmission (communication) devices, nuclear power control devices, or medical life support equipment, due to these devices inherent requirements of extremely high levels of safety and reliability.
- When using the LT with transportation vehicles (trains, cars and ships), disaster and crime prevention devices, various types of safety equipment, non-life support related medical devices, etc. be sure to use redundant and/or failsafe system designs ensure the proper degree of reliability and safety.



## WARNINGS

- After the LT's backlight burns out, unlike the LT's "Standby Mode", the touch panel is still active. If the operator fails to notice that the backlight is burned out and touches the panel, a potentially dangerous machine operation error can occur.
  - 1) If your LT is not set to "Standby Mode" and the screen has gone blank, your backlight is burned out.
  - 2) Or, if your LT is set to Standby Mode, but touching the screen does not cause the display to reappear, your backlight is burned out.

Also, to prevent an accidental machine operation error, Pro-face suggests you use the LT's built-in "USE TOUCH PANEL AFTER BACKLIGHT BURNOUT" feature, that will automatically detect a burnout and disable the touch screen.

**▼Reference▲** *LT Series User Manual 6.4.3 SET UP TOUCH PANEL*

### *Installation:*

- High voltage runs through the LT. Except for replacing the backlight, never disassemble the LT, otherwise an electric shock can occur.
- Do not modify the LT unit. Doing so may cause a fire or an electric shock.
- Do not use the LT in an environment where flammable gasses are present, since operating the LT may cause an explosion.

### *Wiring:*

- To prevent electric shock or equipment damage, prior to installing or wiring the LT, be sure that the LT's power cord is unplugged from the power supply.
- Be sure to reattach the LT terminal block's plastic cover after completing any terminal wiring. If this cover is not reattached, an electric shock could easily occur.
- High voltage runs through the LT. Except for changing the backlight, do NOT attempt to open the LT, since there is a possibility of an electric shock.
- Do not use power levels with the LT that are outside of the LT's specified power range. Doing so may cause a fire, electric shock or damage the LT.

### *Operation and Maintenance:*

- Do not touch a live power terminal. This could cause a shock or machine malfunction.
- Due to the danger of an electric shock, be sure to confirm that the LT's power cord is unplugged before either cleaning the LT or attaching/detaching the power terminal block screws.
- When replacing the LT's backlight, be sure to unplug the unit's power cord to prevent a shock, and wear gloves to prevent being burned.
- The LT uses a lithium battery for backing up its internal clock and control memory data. If the battery is incorrectly replaced (i.e. the + and - sides are reversed), the battery may explode. Therefore, before changing the battery, Pro-face recommends that you contact your local LT distributor for battery replacement instructions.
- Do not modify the LT's internal parts or wiring, since doing so may lead to either a shock or fire.



## CAUTIONS

### *Wiring Layout:*

- Be sure that all LT input/output signal lines are isolated from all power wiring or power cables, via a separate wiring duct. This is to prevent excessive noise, which can cause a unit malfunction.

### *Installation:*

- Be sure all data cables attached to the LT are securely connected. If all connector pins do not make complete contact, incorrect input or output signals can result.

### *General Wiring:*

- To prevent shocks or malfunctions, LT's FG (earth) wire should be grounded according to the following:
  - 1) Be sure to use a maximum grounding resistance of  $100\Omega$  or less.
  - 2) A grounding wire of  $2\text{mm}^2$  or larger should be used.
- Be sure to confirm that the LT's operating voltage and wiring terminal locations are correct. If either are incorrect, it can cause a fire or accident.
- Be sure to secure all wiring terminal screws in place with the designated torque. Screws and terminals that become loose can cause a short circuit, fire or accident.
- Be sure that metal filings or wiring remnants do not fall inside the LT, since they can cause a fire, accident, or malfunction.

### *LT Operation and Maintenance:*

- Be sure to read the LT's manual and on-line help information carefully before performing program changes, forced output, or utilizing the RUN, STOP or PAUSE commands while the LT is in operation. Mistakes concerning the use of these items can cause an accident or equipment or damage.
- Attach or remove I/O units after confirming a LT unit is unplugged, or it can cause the unit damages or malfunctions.
- The LT's liquid crystal display contains a powerful irritant and if for any reason the panel is damaged and this liquid enters your eye, flush your eye for 15 minutes with running water and contact a physician.

### *LT Unit Disposal:*

- Be sure to dispose of the LT unit in a manner appropriate to your country's industrial machinery disposal standards.

## UL/c-UL Application Notes

The GLC150-BG41-XY32KF-24V/GLC150-SC41-XY32KF-24V are UL/c-UL listed products. (UL file No. E182139)

These units conform as products to the following standards:

■UL508

Industrial Control Equipment

■UL1604

Electrical Equipment for Use in Class I and II Division 2 and Class III Hazardous (Classified) Locations

■CAN/CSA-C22.2, No.1010-1

Safety requirements for electrical equipment for measurement, control and laboratory use

**GLC150-BG41-XY32KF-24V (UL Registration Model : 3080060)**

**GLC150-SC41-XY32KF-24V (UL Registration Model : 3280027-12)**

### <Cautions>

- The LT unit must be used as a built-in component of an end-use product.
- The LT unit must be installed with the front face facing outwards.
- If this unit is installed so as to cool itself naturally, be sure to install it in a vertical panel. Also, be sure that the LT unit is mounted at least 100 mm away from any adjacent structures or equipment. If these requirements are not met, the heat generated by the LT unit's internal components may cause the unit to fail to meet UL/c-UL standard requirements.
- Separate the LT unit's power and signal lines from the main power supply via double or reinforced insulation.

### **UL1604 Conditions of Acceptability and Handling Cautions:**

1. Power, input and output (I/O) wiring must all be in accordance with Class I, Division 2 wiring methods, Article 501-4 (b) of the National Electrical Code, NFPA 70, or as specified in Section 18-152 of the Canadian Electrical Code for units installed within Canada, and in accordance with that location's authority.
2. Suitable for use in Class I, Division 2, Groups A, B, C and D hazardous locations, or nonhazardous locations only.
3. **WARNING:** Explosion hazard - substitution of components may impair suitability for Class I, Division 2.
4. **WARNING:** Explosion hazard - do not disconnect equipment unless power has been switched OFF or the area is known to be nonhazardous.
5. **WARNING:** Explosion hazard - when in hazardous locations, turn OFF power before replacing or wiring modules.

## CE Marking Notes

The GLC150-BG41-XY32KF-24V/GLC150-SC41-XY32KF-24V are CE marked, EMC compliant products. These units also conform to EN55011 Class A, EN61000-6-2 directives.

For detailed CE marking information, please contact your local LT distributor.

# CNS Notes

The GLC150-BG41-XY32KF-24V unit complies with the following CNS standards:

- CNS 13438 (Class A)

<Cautions>

The LT unit is designated as Class A industrial equipment. Therefore, when using this unit in a residential area, be careful to avoid electromagnetic interference from nearby home appliances.

<警告使用者>

這是甲類的資訊產品、在居住的環境中使用時、可能會造成射頻干擾、在這種情況下、使用者會被要求採取某些適當的對策。

# Package Contents

The following items are included in the LT's package. Before using the LT, please confirm that all items shown here are present.

■ **LT Unit (1)**

(GLC150-BG41-XY32KF-24V  
GLC150-SC41-XY32KF-24V)

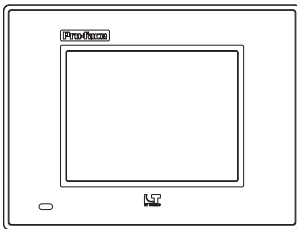

■ **Installation Guide (1)**

<This Guide>

■ **Installation Fasteners (4)**

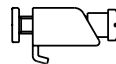

■ **Flex Network I/F Connector (1)**

■ **Installation Gasket (1)**

This unit has been carefully packed, with special attention to quality. However, should you find any of the items shown here to be damaged or missing, please contact your local LT distributor immediately.

# Option Items (sold separately)

■ **LT Series User Manual**

■ **Data Transfer Cable (GPW-CB02)**

■ **USB Data Transfer Cable (GPW-CB03)\*1**

■ **Maintenance Options**

**Installation Fastener (GP070-AT01)**

**Installation Gasket**

**(GP37W2-WP00-MS)**

**Flex Network I/F Connectors**

Phoenix Contact	MC1,5/6-STF-3,81
Digital Elec. Corp.	FN-IFCN01 (5 pieces)

■ **Flex Network Communication Cables**

10m	FN-CABLE2010-31-MS
50m	FN-CABLE2050-31-MS
200m	FN-CABLE2200-31-MS

■ **Logic Program Development Software**

**GP-PRO/PB III C-Package03**

**LT Editor Ver.1.04 or higher**

\* LT Color-type units can only be operated using GP-PRO/PBIII C-Package03 or later. For detailed software compatibility information, please refer to the LT User Manual.

■ **Option**

**Screen Protection Sheet**

**(GP37W2-DF00)**

■ **DIO Connector**

GLC100-DIOCN01	Soldered connectors and cover. (5 sets) Connector:Fujitsu Component Limited (FCN-361J040-AU) Cover:Fujitsu Component Limited (FCN-360C040-B)
GLC-DIOCN02	Ribbon cable crimp connector. (5) Fujitsu Component Limited (FCN-367J040-AU/F)

■ **DIO Cable**

CGP070-ID11-M	Attached to Fujitsu Component Limited (FCN-361J040-AU) connector and Fujitsu Component Limited (FCN-360C040-B) cover. (3.5m) Cable components: Power/Common: AWG#22/Approved for 7A current (red/black) I/O Signal: AWG#24/Approved for 5A current (yellow/green) Includes wire marking cover (not terminated)
---------------	--

\*1 Software version restrictions apply.

**Reference** For details, *USB Data Transfer Cable Installation Guide*.

# 1

## Part Names

The LT's part names and their functions are explained below.

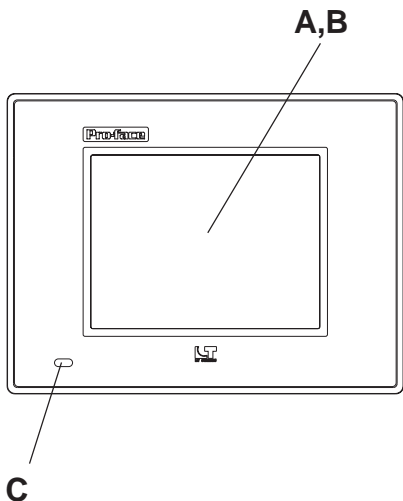

A : Display : Displays controller and user-created screen data.

B : Touch Panel : Enables the user to perform screen change operations or input data.

C : Status LED :

Operation Mode <sup>*1</sup>	Controller Operation Mode <sup>*2</sup>	LED Color
OFFLINE	STOP	Green - Constant
In Operation	RUN	Green - Constant
In Operation	STOP	Green - Flashing
In Operation	Backlight burnout has occurred	Green / Red - Constant
In Operation	Major Error (STOP)	Red - Constant

*\*1 Operation mode includes Display, and touch key features.*

*\*2 Includes the performance of logic program features.*

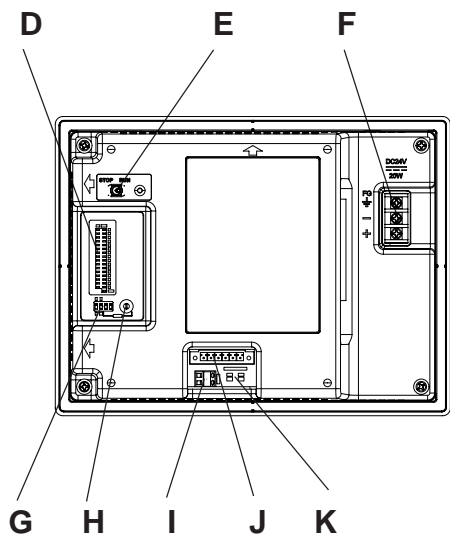

D : Input / Output LED :

Indicates the Input / Output of DIN / DOUT signal.

E : RUN/STOP Switch (LED lights during RUN mode.) : RUN - Indicates the logic program is operating.

STOP - Indicates the logic program has stopped.

F : Power Input Terminal Block :

The input and ground terminals for the DC power cable.

G : Dip Switches

These switches control the I/O connector's Output Hold. Also, they are used to set the S-No.'s left-most hex digit.

H : Rotary Switch

Used to set the S-No.'s right-most hex digit.



<Switch settings>

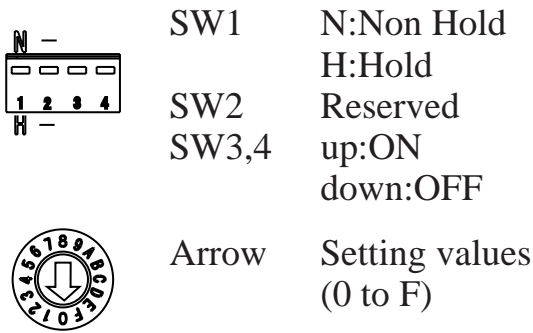

<Example of S-No. (Station No.) settings>

S-No.	Dip Switch		Rotary Switch
	SW3	SW4	
10h(16)	OFF(0)	ON(1)	0
3Fh(63)	ON(1)	ON(1)	F



- A total of 63 stations (nodes) can be set, from 01h to 3Fh.
- The factory setting used for the I/O connector is 01h. Thus, the number of stations (nodes) that can be connected to this unit is a total of 62.
- When using the Flex Network system, be sure that none of the station numbers overlap, i.e. are duplicated.



- The Flex Network data transfer speed is set via the Flex Network Driver settings.

I : Alarm Output :

Turns OFF (Releases) the designated contact when a major or watchdogtimer error occurs.

**Reference** Alarm Output Circuit

J : Flex Network I/F

K : Flex Network LED

Status LED	Indicates
RUN (Green)	ON when communication is normal
ERR (Red)	ON when an error occurs in a connected I/O unit

L : Input / Output Connector :

Connects to an external I/O device. Uses one Flex Network S-No.

M: Tool Connector :

Data Transfer cable is connected here.

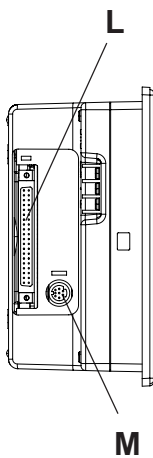

■ Alarm Output Circuit

Turning the LT unit ON will start the unit's system software and the alarm output circuit's relay. When a major error triggers a watchdogtimer alarm, however, this relay will turn OFF. Since an undefined LT input or output condition can occur, be sure to design an external failsafe circuit that will monitor the output of this relay.





When the LT unit's power is turned ON, the Alarm Output is turned OFF for approximately 1 second. Therefore, be sure to design your circuits so that they disregard a 1 second Alarm Output stop after the LT unit's power is turned ON.

Example: Insert an external timer in series with the Alarm Output that turns OFF 1.5 seconds after power is turned ON.

For circuit design examples, LT Series User Manual 2.2.5 External Interface ■ Alarm Output

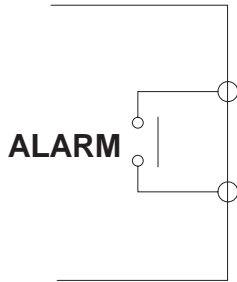

Contact Rating	0.15A-AC125V (Resistance Load) 0.6A-DC24V (Resistance Load)
Operating Time (Set Time at 20°C)	4ms or less
Recover Time (Reset Time at 20°C)	4ms or less
Minimum switching load	1mA / DC5V
Initial Contact Resistance	100mΩ or less

## 2

## General Specifications

Rated Voltage	DC24V
Voltage Supply Range	DC20.4V to 28.8V
Allowable Voltage Drop Interval	10ms or less
Ambient Operating Temperature	0°C to 50°C
Ambient Humidity	10%RH to 90%RH (no condensation, wet bulb temperature: 39°C max. )
Atmospheric Pressure	800hPa to 1114hPa (2000 meter or less)
Atmosphere	Pollution Degree 2

### 3

## Dimensions

The LT unit dimensions are as follows.

(Unit:mm [in.] : excluding projections)

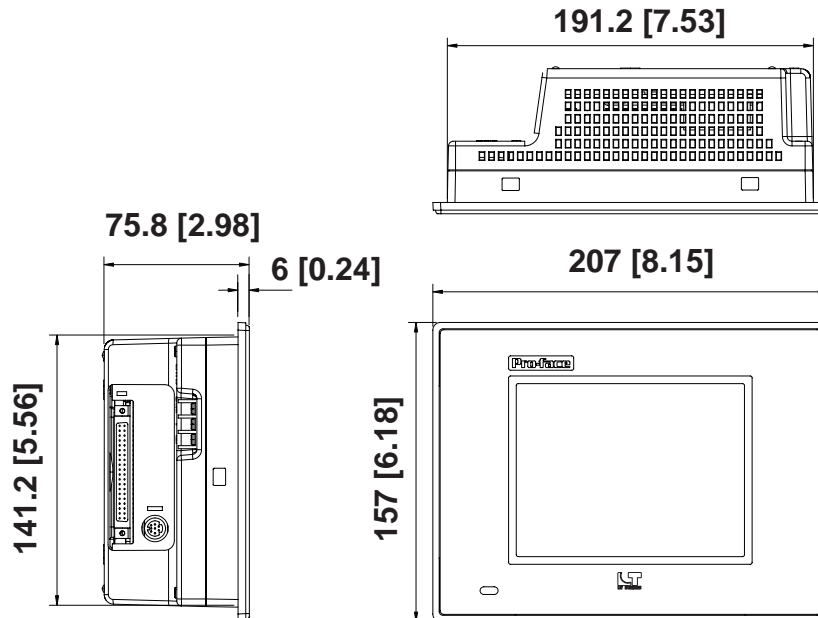

### 4

## Interfaces

### Flex Network Interface

Connects to a Flex Network unit.

Pin Arrangement	Pin No.	Signal
<p>1 2 3 4 5 6</p>	1	CH1 Communication Data (TR +)
	2	CH1 Communication Data (TR -)
	3	CH1 Shielded Line (SLD)
	4	CH2 Communication Data (TR +)
	5	CH2 Communication Data (TR -)
	6	CH2 Shielded Line (SLD)

Recommended Connector : MC1,5/6-STF-3,81 (Made by Phoenix Contact)  
 FN-IFCN01 (Maintenance Option / Digital Electronics Corporation)\*<sup>1</sup>

\*<sup>1</sup> A set of 5 pieces for MC1,5/6-STF-3,81

**Reference** For further information about the Flex Network I/F unit, or connectable Flex Network I/O units, refer to the “Flex Network User Manual”.

## ■ Input/Output Interface

The following table shows the pin assignments for this connector.



*This drawing shows the LT unit's connector.*

*The connector for the I/O cable has "A" and "B" marked at the end of the connector to show the #1 A and B pins. Be sure to identify these pin number marks prior to wiring the cable's connector.*

Pin Arrangement	Pin No.	Signal	Pin No.	Signal
	A1	COM (0V:DOUT)	B1	COM (24V:DIN)
	A2	COM (0V:DOUT)	B2	DC24V (DOUT)
	A3	NC	B3	NC
	A4	NC	B4	NC
	A5	DOUT 15	B5	DIN 15
	A6	DOUT 14	B6	DIN 14
	A7	DOUT 13	B7	DIN 13
	A8	DOUT 12	B8	DIN 12
	A9	DOUT 11	B9	DIN 11
	A10	DOUT 10	B10	DIN 10
	A11	DOUT 9	B11	DIN 9
	A12	DOUT 8	B12	DIN 8
	A13	DOUT 7	B13	DIN 7
	A14	DOUT 6	B14	DIN 6
	A15	DOUT 5	B15	DIN 5
	A16	DOUT 4	B16	DIN 4
	A17	DOUT 3	B17	DIN 3
	A18	DOUT 2	B18	DIN 2
	A19	DOUT 1	B19	DIN 1
	A20	DOUT 0	B20	DIN 0

- **Recommended Connectors and Connector Covers**

<b>Connector Type</b>	Connector Model Numbers (made by Fujitsu Component Limited.)
<b>Solder</b>	FCN-361J040-AU (Connector) FCN-360C040-B (Cover)
<b>Crimp</b>	FCN-363J040 (Connector) FCN-363J040-AU/S (Contact) FCN-360C040-B (Cover)
<b>Pressure</b>	FCN-367J040-AU/F (Contact)

<b>Connector Type</b>	Connector Model Numbers (made by Digital Electronics Corporation)
<b>Solder</b>	GLC100-DIOCN01 (Connector / Cover) 5 pieces <sup>*1</sup>
<b>Pressure</b> <sup>*3</sup>	GLC-DIOCN02 (Contact) 5 pieces <sup>*2</sup>

*\*1 A set of 5 pieces for FCN-361J040-AU (Connector) / FCN-360C040-B (Cover)*

*\*2 A set of 5 pieces for FCN-367J040-AU/F*

*\*3 Cable type: Flat cable - 1.27 mm pitch AWG#28 (Lay wire)/AWG#30 (Solid wire)*

- **Input/Output Specifications**

		Input	Output
Rated Voltage		DC24V	
Common Lines		1	
Input/Output Points		16	16
Input/Output Signal Display		LED lights when each point turns ON (logical side)	
Isolation Method		Photocoupler Isolation	
External Power Supply		For Signal : DC24V	
Allowable Voltage		Maximum DC26.4V	DC24V ± 10%
Input/Output Delay Time	OFF to ON	1.5ms or less	1.0ms or less
	ON to OFF	1.5ms or less	1.0ms or less
Input Rated Current		5.7mA (24V)	—————
Input Resistance		4.2kΩ	—————
Operation Range	ON Voltage	15V or more	—————
	OFF Voltage	5V or less	—————
Output Method		—————	Sink Output
Maximum Load Voltage		—————	0.2A/point, 1.6A/Common
Output Voltage Drop		—————	1.5V or less
Current Leakage (when OFF)		—————	0.1mA or less
Type of Output		—————	Transistor Output
Output Protection Type		—————	Output is unprotected
Internal Fuse		—————	3.5A, 125V Chip Fuse (cannot be replaced)
Surge Control Circuit		—————	Diode

- **Input Circuit**

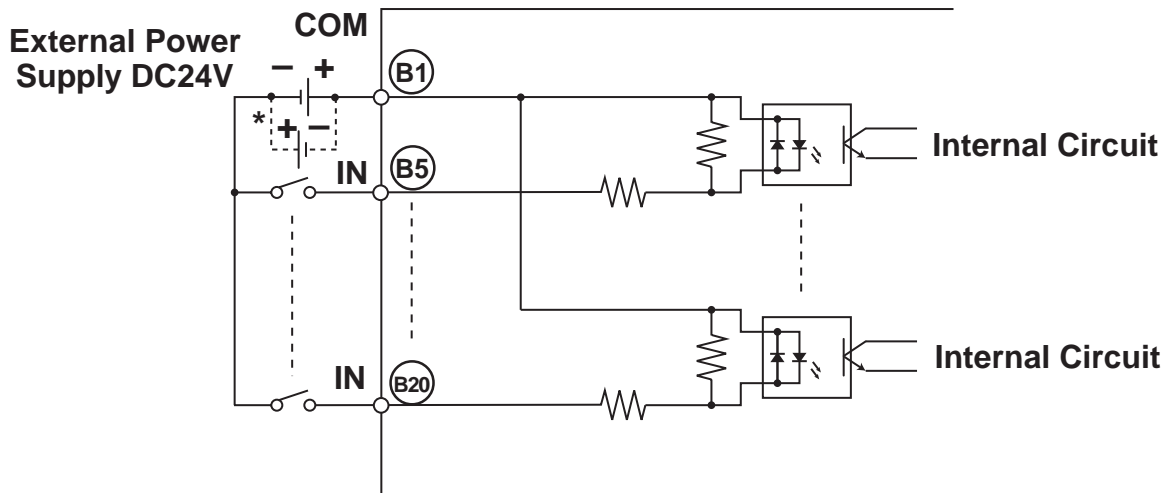

\* Dotted line shows the source output device connection.

- **Output Circuit**

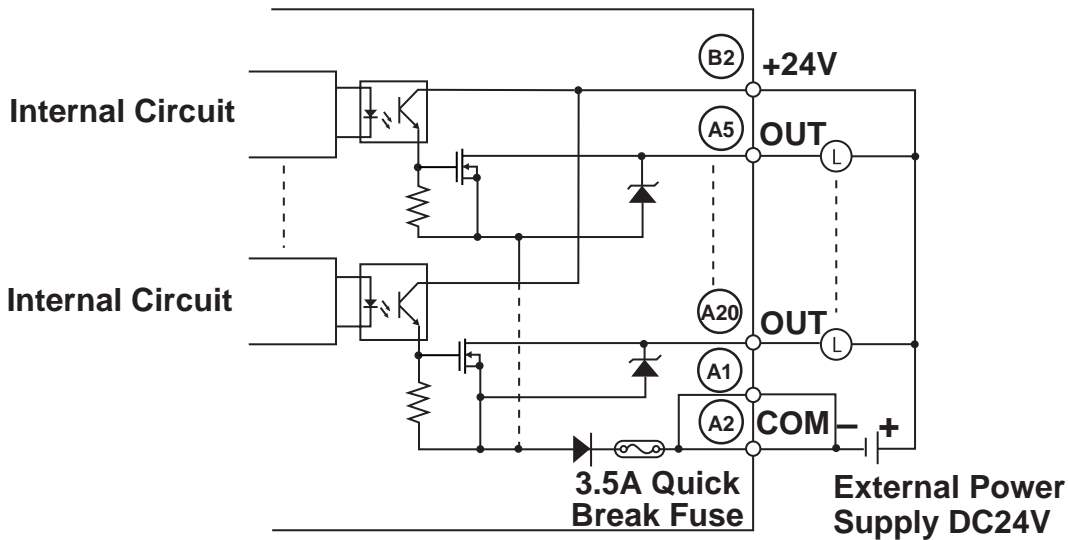

## 5 Installation

- **Confirm the Installation Gasket's Positioning**

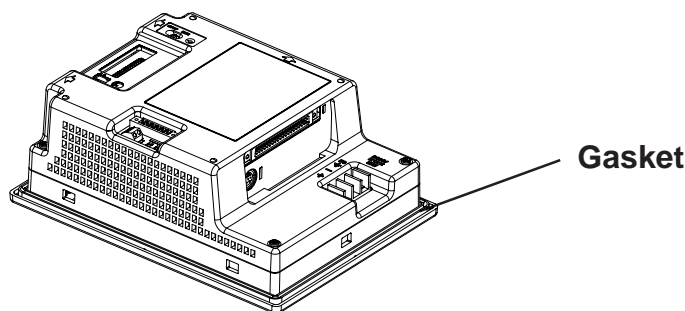

Before installing the LT into a cabinet or panel, check that the installation gasket is securely attached to the unit.

■ Create a Panel Cut and insert the LT into the panel from the front

Unit:mm [in.]

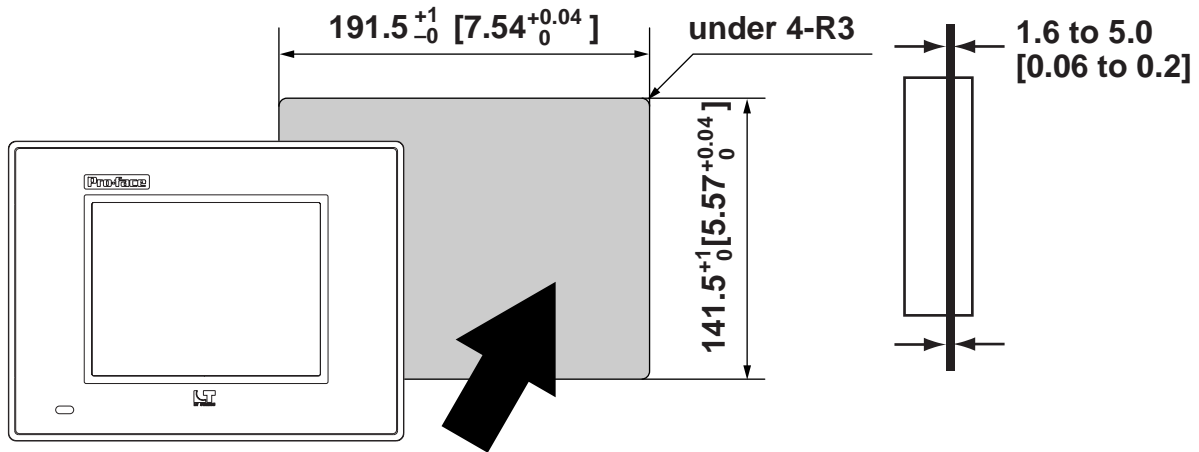

■ Attach the Installation Fasteners from Inside the Panel

The following figures show the four (4) fastener insertion slot locations. Insert each fastener's hook into the slot and pull it back until the hook catches.

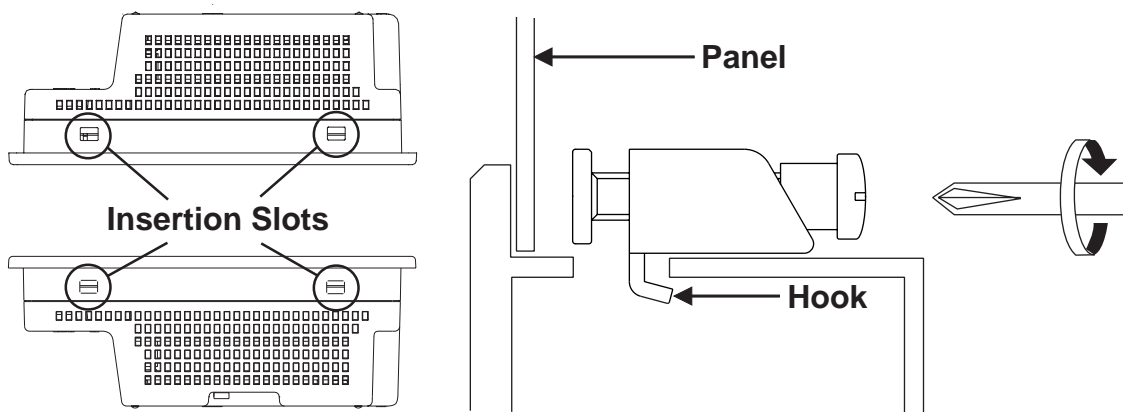

- Tightening the screws with too much force can damage the LT's plastic case.
- The necessary torque is 0.5 to 0.6 N•m.



- You can purchase replacement fasteners and gaskets from your local LT distributor.

# 6

# Wiring



## WARNINGS

- To prevent an electric shock, prior to connecting the LT's power cord terminals to the power terminal block, be sure that the LT's power supply is turned OFF, via a breaker, or similar unit.
- The LT units are designed to use only DC24V input. Any other power level can damage both the LT and the power supply.
- To prevent an electric shock or equipment damage, be sure to reattach the plastic cover to the terminal block after completing any wiring.



- To avoid a short caused by loose ring terminals, be sure to use ring terminals with an insulating sleeve.\*1
- When the FG terminal is connected, be sure the wire is grounded. Not grounding the LT unit will result in excess noise and vibration.



- **Note:** Wherever possible, use thick wires (max. 2 mm<sup>2</sup>) for power terminals, and twist the wire ends before attaching the ring terminals.
- Be sure to use the following size ring terminals.

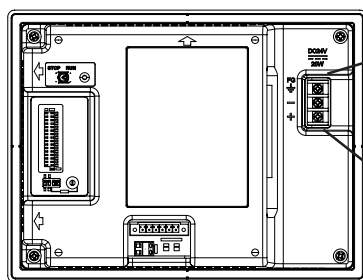
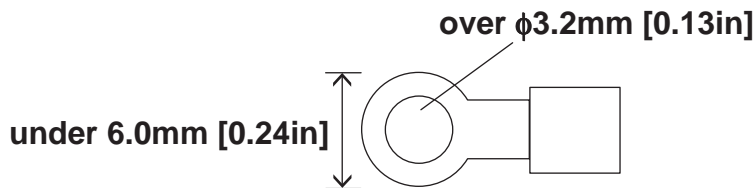

Rear View



Power Input Terminal Block

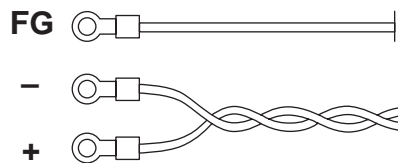

Power Supply DC24V

### ■ Connecting the LT Power Cord

When connecting the power cord, be sure to follow the procedures given below.

1. Confirm that the LT's Power Cord is unplugged from the power supply.
2. Use a screwdriver to remove the Power Input Terminal Block's clear plastic cover.
3. Unscrew the screws from the middle three (3) terminals, align the Ring Terminals and reattach the screws.
4. Confirm that the wires are connected correctly.
5. Replace the Power Input Terminal Block's clear plastic cover.



**Note:** The torque required to tighten these screws is 0.5 to 0.6 N·m.

\*1 Suggested Ring Terminal : V2-MS3 (made by JST)



## 7

# Power Supply Cautions

Please pay special attention to the following instructions when connecting the power cord terminals to the LT unit.

- If the power supply voltage exceeds the LT's specified range, connect a voltage transformer.
- Between the line and the ground, be sure to use a low noise power supply. If there is still an excessive amount of noise, connect a noise reducing transformer.
- Input and Output signal lines must be separated from the power control cables for operational circuits.
- To increase the noise resistance, be sure to twist the ends of the power cord wires before connecting it to the LT unit.
- The LT's power supply cord should not be bundled with or kept close to main circuit lines (high voltage, high current), or input/output signal lines.
- Connect a surge absorber to handle power surges.
- To reduce noise, make the power cord as short as possible.

## 8

# Grounding Cautions

- When attaching a wire to the LT's rear face FG terminal, (on the Power Input Terminal Block), be sure to create an exclusive ground\*<sup>1</sup>.
- FG and SG terminals are internally connected in the LT. When connecting to another device, be sure to not create an SG shorting loop in your system.
- When attaching an expansion unit to the LT, be sure to read the expansion unit's Installation Guide.
- The grounding electric wire must be independent, not crossing over other wires.

## 9

# Input/Output Signal Line Cautions

- All LT Input and Output signal lines must be separated from all operating circuit (power) cables.
- If this is not possible, use a shielded cable and ground the shield.

## 10

# Maintenance and Periodic Inspection

When dirt collects on the surface or the frame of the display, soak a soft cloth in water with a neutral detergent, wring the cloth tightly, and wipe the display.



- *Do not use paint thinner, organic solvents, or strong acid compound to clean the unit.*
- *Do not use hard or pointed objects to operate the touch-screen panel, since it can damage the panel surface.*

\*<sup>1</sup> Use a grounding resistance of 100Ω, a wire of 2mm<sup>2</sup> or thicker, or your country's applicable standard.