

# PS-4700/4800 Series

## User Manual

(Atom N270/Core 2 Duo P8400 Pre-installed Model)



---

The information provided in this documentation contains general descriptions and/or technical characteristics of the performance of the products contained herein. This documentation is not intended as a substitute for and is not to be used for determining suitability or reliability of these products for specific user applications. It is the duty of any such user or integrator to perform the appropriate and complete risk analysis, evaluation and testing of the products with respect to the relevant specific application or use thereof. Neither Pro-face nor any of its affiliates or subsidiaries shall be responsible or liable for misuse of the information contained herein. If you have any suggestions for improvements or amendments or have found errors in this publication, please notify us.

No part of this document may be reproduced in any form or by any means, electronic or mechanical, including photocopying, without express written permission of Pro-face.

All pertinent state, regional, and local safety regulations must be observed when installing and using this product. For reasons of safety and to help ensure compliance with documented system data, only the manufacturer should perform repairs to components.

When devices are used for applications with technical safety requirements, the relevant instructions must be followed.

Failure to use Pro-face software or approved software with our hardware products may result in injury, harm, or improper operating results.

Failure to observe this information can result in injury or equipment damage.

Copyright © 2014.9 Digital Electronics Corporation. All Rights Reserved.

## Table of Contents

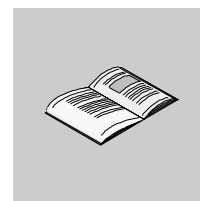

	<b>Safety Information</b> .....	<b>5</b>
	<b>About the Book</b> .....	<b>7</b>
<b>Part I</b>	<b>General Overview</b> .....	<b>13</b>
<b>Chapter 1</b>	<b>Important Information</b> .....	<b>15</b>
	Federal Communications Commission Radio Frequency Interference Statement - For U.S.A. ....	16
	Qualified Personnel .....	17
	Certifications and Standards .....	18
	European (CE) Compliance .....	20
	Hazardous Location Installations - For USA and Canada .....	21
	Marine Installations - For Germanischer Lloyd (GL) .....	26
<b>Chapter 2</b>	<b>Physical Overview</b> .....	<b>27</b>
	Package Contents .....	28
	Industrial Personal Computer 15" - 0 slot Description .....	30
	Industrial Personal Computer 15" - 1 slots Description .....	34
	Industrial Personal Computer 15" - 2 slots Description .....	38
	Industrial Personal Computer 19" - 0 slot Description .....	42
	Industrial Personal Computer 19" - 1 slots Description .....	46
	Industrial Personal Computer 19" - 2 slots Description .....	50
	Industrial Personal Computer LED Description .....	54
<b>Chapter 3</b>	<b>Characteristics</b> .....	<b>55</b>
	Industrial Personal Computer Characteristics .....	56
	Industrial Personal Computer Interface Characteristics .....	60
	Environmental Characteristics .....	61
<b>Chapter 4</b>	<b>Dimensions/Assembly</b> .....	<b>63</b>
	Industrial Personal Computer 15" Dimensions .....	64
	Industrial Personal Computer 19" Dimensions .....	71
	Installation Requirements .....	78
	Industrial Personal Computer Installation .....	82
<b>Part II</b>	<b>Implementation</b> .....	<b>85</b>
<b>Chapter 5</b>	<b>Getting Started</b> .....	<b>87</b>
	First Power-up .....	87
<b>Chapter 6</b>	<b>Industrial Personal Computer Connections</b> .....	<b>89</b>
	Grounding .....	90
	Connecting the DC Power Cord .....	94
	Connecting the AC Power Cord .....	97
	Industrial Personal Computer Interface Connections .....	99

<b>Chapter 7</b>	<b>Configuration of the BIOS</b> .....	<b>107</b>
	BIOS Options .....	108
	Main Menu .....	110
	Advanced Menu - USB Configuration .....	112
	Boot Menu .....	115
	Security Menu .....	117
	Exit Menu .....	119
<b>Chapter 8</b>	<b>Hardware Modifications</b> .....	<b>121</b>
	Before Modifications .....	122
	Uninterruptible Power Supply (UPS) .....	124
	PCI / PCIe Card Installation .....	131
	Compact Flash (CF) Card Installation and Removal .....	135
<b>Part III</b>	<b>Installation</b> .....	<b>137</b>
<b>Chapter 9</b>	<b>System Monitor</b> .....	<b>139</b>
	System Monitor Interface .....	140
	System Monitor Setting .....	146
<b>Chapter 10</b>	<b>Maintenance</b> .....	<b>149</b>
	Reinstallation Procedure .....	150
	Regular Cleaning and Maintenance .....	151
<b>Appendices</b>	.....	<b>159</b>
<b>Chapter 11</b>	<b>Accessories</b> .....	<b>161</b>
	Accessories for the Industrial Personal Computer .....	161
<b>Chapter 12</b>	<b>After-sales service</b> .....	<b>163</b>

## Safety Information

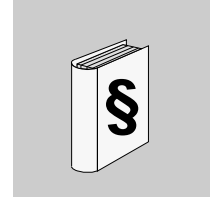

### Important Information

#### NOTICE

Read these instructions carefully, and look at the equipment to become familiar with the device before trying to install, operate, or maintain it. The following special messages may appear throughout this documentation or on the equipment to warn of potential hazards or to call attention to information that clarifies or simplifies a procedure.



The addition of this symbol to a “Danger” or “Warning” safety label indicates that an electrical hazard exists which will result in personal injury if the instructions are not followed.



This is the safety alert symbol. It is used to alert you to potential personal injury hazards. Obey all safety messages that follow this symbol to avoid possible injury or death.

### **DANGER**

**DANGER** indicates a hazardous situation which, if not avoided, **will result in** death or serious injury.

### **WARNING**

**WARNING** indicates a hazardous situation which, if not avoided, **could result in** death or serious injury.

### **CAUTION**

**CAUTION** indicates a hazardous situation which, if not avoided, **could result in** minor or moderate injury.

### **NOTICE**

**NOTICE** is used to address practices not related to physical injury.

**PLEASE NOTE**

Electrical equipment should be installed, operated, serviced, and maintained only by qualified personnel. No responsibility is assumed by Pro-face for any consequences arising out of the use of this material.

A qualified person is one who has skills and knowledge related to the construction and operation of electrical equipment and its installation, and has received safety training to recognize and avoid the hazards involved.

## About the Book

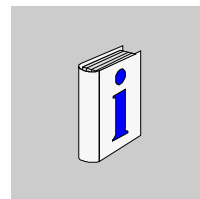

### At a Glance

Thank you for purchasing Pro-face's PS-4700/4800 Series (Atom N270/Core 2 Duo P8400 Pre-installed Model) (Hereafter referred to as the "Industrial Personal Computer").

### Document Scope

Character Number	1-4	5	6	7	8	9	10	11	12	13	14	15	16	17	18
Part Number Example	PFXP	P	1	7	1	B	D	2	3	K	1	4	N	0	0
iPC Family	Atom N270/Core 2 Duo P8400 Pre-installed Model	P													
	Atom N270/Core 2 Duo P8400 Pre-installed Stainless Steel Bezel Model	T													
iPC Generation	Reserved		*												
Display	15"-XGA			7											
	19"-SXGA			8											
Expansion Slot	0 slot				0										
	1 slot = 1 PCI				1										
	2 slots = 1 PCI + 1 PCIe				2										
	2 slots = 2 PCI				A										
CPU Type	Atom N270					B									
	Core2 Duo P8400					C									
Power Supply	AC					A									
	DC with I/F for UPS battery unit					B									
	DC					D									
	DC with Noise Filter for Marine Certification					F									
	DC with I/F for UPS battery unit and Noise Filter for Marine Certification					G									
RAM (Configuration available depend on CPU)	1GB							1							
	2GB							2							
	3GB = 1GB + 2GB							3							
	4GB = 2GB + 2GB							4							
	6GB = 2GB + 4GB							6							
	8GB = 4GB + 4GB							8							

Character Number	1-4	5	6	7	8	9	10	11	12	13	14	15	16	17	18
Operating System	None								0						
	Windows Embedded Standard 2009 MUI								1						
	Windows XP Pro Japanese								2						
	Windows XP Pro MUI								3						
	Windows Embedded Standard 7 MUI (32bit)								4						
	Windows 7 Ultimate MUI (32bit)								5						
	Windows 7 Ultimate MUI (64bit)								6						
Storage Device	None									N					
	CF Card 4GB									C					
	CF Card 8GB									D					
	HDD									K					
	SSD									T					
Slide-in Slot	None									0					
	DVD multi drive									1					
	HDD									2					
	SSD									3					
Options	None									0					
	COM Expansion Board RS-232C/422/485									4					
Software Bundle	None												N		
Reserved	Reserved													*	
Reserved	Reserved														*



## **Validity Note**

This documentation is valid for PS-4700/4800 Series (Atom N270/Core 2 Duo P8400 Pre-installed Model).

The technical characteristics of the device(s) described in this manual appear online. To access this information online, please go to our site <http://www.pro-face.com/otasuke/>

The characteristics presented in this manual should be constantly improved for clarity and accuracy. In the event that you see a difference between the manual in your PC and online information, use the online information as your reference.

### Registered Trademarks

The company names and product names used in this manual are the trade names, trademarks (including registered trademarks), and service marks of their respective companies. This product omits individual descriptions of each of these rights.

Trademark / Tradename	Right Holder
Microsoft, Windows	Microsoft, U.S.
Pro-face	Digital Electronics Corporation (in Japan and other countries)
Intel	Intel Corporation
Adobe	Adobe Systems Incorporated

The following terms differ from the abovementioned trade names and trademarks.

Term used in this manual	Formal Trademark or Tradename
Windows Embedded Standard 2009	Microsoft® Windows® Embedded Standard Runtime
Windows Embedded Standard 7	Windows® Embedded Standard 7 Runtime (WS7P)(ESD)
Windows XP Pro	Microsoft® Windows® XP Professional for Embedded Systems (1-2 CPU) ESD
Windows 7	Windows® 7 Ultimate for Embedded Systems x32/x64 (1-2 CPU) (ESD)
Adobe Reader	Adobe® Reader®
Atom N270	Intel® Atom™ Processor N270
Core 2 Duo	Intel® Core™ 2 Duo Processor P8400

### Related Documents

Title of Documentation
PS-4700/4800 Series (Atom N270/Core 2 Duo P8400 Pre-installed Model) User Manual (this manual)

You can download these technical publications and other technical information from our website "Otasuke Pro!" at <http://www.pro-face.com/otasuke/>.

### Global Code

A global code is assigned to every Pro-face product as a universal reference. For more information on product models and their matching global codes, please refer to the following URL.

URL: <http://www.pro-face.com/product/globalcode.html>

## Product Related Information

Industrial Personal Computers are certified for use in Class I, Division 2 hazardous locations as defined in ANSI/ISA 12.12.01 or CSA C22.2 N°213. Observe the following:

### DANGER

#### HAZARD OF ELECTRIC SHOCK, EXPLOSION OR ARC FLASH

- Remove all power from the device before removing any covers or elements of the system, and prior to installing or removing any accessories, hardware, or cables.
- Unplug the power cable from both the Industrial Personal Computer and the power supply.
- Always use a properly rated voltage sensing device to confirm power is off.
- Replace and secure all covers or elements of the system before applying power to the unit.
- Use only the specified voltage when operating the Industrial Personal Computer. The AC unit is designed to use 100...240 Vac input. The DC unit is designed to use 24 Vdc. Always check whether your device is AC or DC powered before applying power.

**Failure to follow these instructions will result in death or serious injury.**

### WARNING

#### LOSS OF CONTROL

- The designer of any control scheme must consider the potential failure modes of control paths and, for certain critical control functions, provide a means to achieve a safe state during and after a path failure. Examples of critical control functions are emergency stop and overtravel stop.
- Separate or redundant control paths must be provided for critical control functions.
- System control paths may include communication links. Consideration must be given to the implications of unanticipated transmission delays or failures of the link.(1)
- Each implementation of a Industrial Personal Computer must be individually and thoroughly tested for proper operation before being placed into service.

**Failure to follow these instructions can result in death, serious injury, or equipment damage.**

(1) For additional information, refer to *NEMA ICS 1.1 (latest edition), "Safety Guidelines for the Application, Installation, and Maintenance of Solid State Control"* and to *NEMA ICS 7.1 (latest edition), "Safety Standards for Construction and Guide for Selection, Installation and Operation of Adjustable-Speed Drive Systems"* or other applicable standards in your location.

**NOTE:** Industrial Personal Computer is a highly configurable device and is not based on a real-time operating system. Changes to the software and settings of the following must be considered new implementations as discussed in the previous warning messages. Examples of such changes include:

- System BIOS
- System Monitor
- Operating system
- Installed hardware

- Installed software

 **WARNING**

**UNINTENDED EQUIPMENT OPERATION**

Use only the software provided with this product. If you use the other software, please confirm the operation and safety before you use.

**Failure to follow these instructions can result in death, serious injury, or equipment damage.**

# General Overview

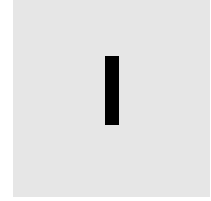

---

## Subject of this Part

This part provides an overview of Industrial Personal Computer.

## What's in this Part?

This part contains the following chapters:

Chapter	Chapter Name	Page
1	Important Information	15
2	Physical Overview	27
3	Characteristics	55
4	Dimensions/Assembly	63



# Important Information

# 1

---

## General

This chapter describes the safety aspects which are specific to the operation of the Industrial Personal Computer.

## What's in this Chapter?

This chapter contains the following topics:

Topic	Page
Federal Communications Commission Radio Frequency Interference Statement - For U.S.A.	16
Qualified Personnel	17
Certifications and Standards	18
European (CE) Compliance	20
Hazardous Location Installations - For USA and Canada	21
Hazardous Location Installations - For ATEX	25
Marine Installations - For Germanischer Lloyd (GL)	26

## Federal Communications Commission Radio Frequency Interference Statement - For U.S.A.

### FCC Radio Interference Information

This equipment has been tested and found to comply with the Federal Communications Commission (FCC) limits for a Class A digital device, pursuant to Part 15 of the FCC Rules. These limits are designed to provide reasonable protection against harmful interference in a commercial, industrial or business environment. This equipment generates, uses, and can radiate radio frequency energy and, if not installed and used in accordance with the instructions, may cause or be subject to interference with radio communications. To minimize the possibility of electromagnetic interference in your application, observe the following two rules:

- Install and operate the Industrial Personal Computer in such a manner that it does not radiate sufficient electromagnetic energy to cause interference in nearby devices.
- Install and test the Industrial Personal Computer to ensure that the electromagnetic energy generated by nearby devices does not interfere with the Industrial Personal Computer's operation.

### **WARNING**

#### **ELECTROMAGNETIC / RADIO INTERFERENCE**

Electromagnetic radiation may disrupt the Industrial Personal Computer's operations, leading to unintended equipment operation. If electromagnetic interference is detected:

- Increase the distance between the Industrial Personal Computer and the interfering equipment.
- Reorient the Industrial Personal Computer and the interfering equipment.
- Reroute power and communication lines to the Industrial Personal Computer and the interfering equipment.
- Connect the Industrial Personal Computer and the interfering equipment to different power supplies.
- Always use shielded cables when connecting the Industrial Personal Computer to a peripheral device or another computer.

**Failure to follow these instructions can result in death, serious injury, or equipment damage.**



## Qualified Personnel

### General

Only qualified personnel can install, operate, and maintain the product. A qualified person is one who has skills and knowledge related to the construction, operation, and installation of electrical equipment, and has received safety training to recognize and avoid the hazards involved. Refer to the most current release of NFPA 70E®, Standard for Electrical Safety in the Workplace, for electrical safety training requirements or other applicable standards in your location. Examples of qualified personnel may include:

- at the application design level, engineering department personnel who are familiar with automation safety concepts (for example, a design engineer)
- at the equipment implementation level, personnel who are familiar with the installation, connection and commissioning of automation equipment (for example, an installation assembly or cabling engineer or a commissioning technician)
- at the operation level, personnel who are experienced in the use and control of automation and computing equipment (for example, an operator)
- for preventive or corrective maintenance, personnel trained and qualified in regulating or repairing automated and computing devices (for example, an operating technician or after-sales service technician.)

## Certifications and Standards

### Agency Certifications

Pro-face submitted this product for independent testing and qualification by third-party agencies. These agencies have certified this product as meeting the following standards.

- Underwriters Laboratories Inc., UL 508 and CSA C22.2 N°142, Industrial Control Equipment
- Underwriters Laboratories Inc., ANSI/ISA 12.12.01 and CSA C22.2 N°213, Electrical Equipment for Use in Class I, Division 2 Hazardous (Classified) Locations
- GOST certification
- ATEX Category 3 Zone 22 certification
- Germanischer Lloyd (GL) Type approval

For information on certifications and standards, such as certified models and certificates, see the following or product markings.

<http://www.pro-face.com/worldwide.html>

### Compliance Standards

Pro-face tested this product for compliance with the following compulsory standards.

United States:

- Federal Communications Commission, FCC Part 15
- Food and Drug Administration, FDA 21 CFR 177 (Installation Gasket: §177.2600) (for the front panel design of Stainless Steel Bezel Model)

Europe:

- CE
  - Directive 2006/95/EC (Low Voltage)
  - Directive 2004/108/EC (EMC)
  - Programmable Controllers: EN 61131-2 (Ed 3)
  - EMI: EN55011 (Group 1, Class A), EN 61000-6-4
  - EMS: EN 61000-6-2
  - Directive 94/9/EC (ATEX)
- EN 1672-2 (for the front panel design of Stainless Steel Bezel Model)

Australia:

- Standard AS/NZS CISPR11 (C-Tick)

### Qualification Standards

Pro-face voluntarily tested this product to additional standards. The additional tests performed, and the standards under which the tests were conducted, are specifically identified in Environmental Characteristics (*see page 61*).

### Hazardous Substances

This product is compliant with:

- WEEE, Directive 2002/96/EC
- RoHS, Directive 2002/95/EC
- RoHS China, Standard SJ/T 11363-2006
- REACH regulation EC 1907/2006

**End of Life (WEEE)**

The product contains electronic boards. It must be disposed of in specific treatment channels. The product contains cells and/or storage batteries which must be collected and processed separately, when they have run out and on product end of life.

Refer to the section maintenance (see page 151) to extract cells and batteries from the product. These batteries do not contain a weight percentage of heavy metals over the threshold notified by European Directive 2006/66/EC.

**KC Marking**

사용자안내문

기종별	사 용 자 안 내 문
A급 기기 (업무용 방송통신기자재)	이 기기는 업무용(A급) 전자파적합기기로서 판매자 또는 사용자는 이 점을 주의하시기 바라며, 가정외의 지역에서 사용하는 것을 목적으로 합니다.

## **European (CE) Compliance**

### **CE Compliance Note**

The products described in this manual comply with the European Directives concerning Electromagnetic Compatibility and Low Voltage (CE marking) when used as specified in the relevant documentation, in applications for which they are specifically intended, and in connection with approved third-party products.

## Hazardous Location Installations - For USA and Canada

### General

The Industrial Personal Computer has been designed with the intention of meeting the requirements of Class I, Division 2 hazardous location applications. Division 2 locations are those locations where ignitable concentrations of flammable substances are normally confined, prevented by ventilation, or present in an adjacent Class I, Division 1 location, but where an abnormal situation might result in intermittent exposure to such ignitable concentrations.

While the Industrial Personal Computer is a non-incendive device under ANSI/ISA 12.12.01 and CSA C22.2 N°213, it is not designed for, and should never be used within a Division 1 (normally hazardous) location.

Industrial Personal Computers are suitable for use in Class I, Division 2, Groups A, B, C, and D hazardous locations or in non-hazardous locations. Before installing or using your Industrial Personal Computer, confirm that the ANSI/ISA 12.12.01 or CSA C22.2 N°213 certification appears on the product labeling

**NOTE:** Some Industrial Personal Computers are not yet rated as suitable for use in hazardous locations. Always use your product in conformance with the product labeling and this manual.

### DANGER

#### EXPLOSION HAZARD

- Do not use your Industrial Personal Computer in hazardous environments or locations other than Class I, Division 2, Groups A, B, C, and D.
- Always confirm that your Industrial Personal Computer is suitable for use in hazardous locations by checking that the ANSI/ISA 12.12.01 or CSA C22.2 N°213 certification appears on the product labeling.
- Do not install any Pro-face or OEM components, equipment, or accessories unless these have also been qualified as suitable for use in Class I, Division 2, Groups A, B, C, and D locations.
- In addition, confirm that any PCI/PCIe controller cards have a temperature code (T-code), and are suitable for an surrounding air temperature range of +0°C to +50°C (32°F to 122°F).
- Do not attempt to install, operate, modify, maintain, service, or otherwise alter the Industrial Personal Computer except as permitted in this manual. Unpermitted actions may impair the unit's suitability for Class I, Division 2 operation.

**Failure to follow these instructions will result in death or serious injury.**

## **DANGER**

### **EXPLOSION HAZARD**

- Always confirm the ANSI/ISA 12.12.01 and CSA C22.2 N°213 hazardous location rating of your device before installing or using it in a hazardous location.
- To power on or power off a Industrial Personal Computer installed in a Class I, Division 2 hazardous location, you must either:
  - Use a switch located outside the hazardous environment, or
  - Use a switch certified for Class I, Division 1 operation inside the hazardous area.
- Do not disconnect equipment unless power has been switched off or the area is known to be non-hazardous. This applies to all connections including power, ground, serial, parallel, and network connections.
- Never use unshielded / ungrounded cables in hazardous locations.
- Use only non-incendive USB configuration.
- When enclosed, keep enclosure doors and openings closed at all times to avoid the accumulation of foreign matter inside the workstation.

**Failure to follow these instructions will result in death or serious injury.**

## **DANGER**

### **HAZARD OF ELECTRIC SHOCK, EXPLOSION OR ARC FLASH**

- Remove all power from the device before removing any covers or elements of the system, and prior to installing or removing any accessories, hardware, or cables.
- Unplug the power cable from both the Industrial Personal Computer and the power supply.
- Always use a properly rated voltage sensing device to confirm power is off.
- Replace and secure all covers or elements of the system before applying power to the unit.
- Use only the specified voltage when operating the Industrial Personal Computer. The AC unit is designed to use 100...240 Vac input. The DC unit is designed to use 24 Vdc. Always check whether your device is AC or DC powered before applying power.

**Failure to follow these instructions will result in death or serious injury.**

Ensure that the product is properly rated for the location. If the intended location does not presently have a Class, Division and Group rating, then users should consult the appropriate authorities having jurisdiction in order to determine the correct rating for that hazardous location.

In accordance with Federal, State/Provincial, and Local regulations, all hazardous location installations should be inspected prior to use by the appropriate authority having jurisdiction. Only technically qualified personnel should install, service, and inspect these systems.

## Power Switch

### **DANGER**

#### **HAZARD OF ELECTRIC SHOCK, EXPLOSION OR ARC FLASH**

- Remove all power from the device before removing any covers or elements of the system, and prior to installing or removing any accessories, hardware, or cables.
- Unplug the power cable from both the Industrial Personal Computer and the power supply.
- Always use a properly rated voltage sensing device to confirm power is off.
- Replace and secure all covers or elements of the system before applying power to the unit.
- Use only the specified voltage when operating the Industrial Personal Computer. The AC unit is designed to use 100...240 Vac input. The DC unit is designed to use 24 Vdc. Always check whether your device is AC or DC powered before applying power.

**Failure to follow these instructions will result in death or serious injury.**

The amount of input power required by systems with a Industrial Personal Computer classifies the power switch as an incendive device because the voltage and current across the make/break component are capable of generating a spark.

If using an ordinary power switch, hazardous location regulations require the power switch be located in an area specified as non-hazardous.

However, limits in cable length between the workstation and the power switch may apply. Otherwise the switch must be compliant with Class I, Division 1 requirements (intrinsically safe). These switches are built in a manner that prevents the possibility of a spark when contact is made or broken.

Use suitable UL listed and/or CSA Certified Class I, Division 1 switches in hazardous locations. These switches are available from a wide number of sources. It is the responsibility to ensure you select a power switch that conforms to the hazardous location rating for the installation.

## Cable Connections

** DANGER**

**EXPLOSION HAZARD**

- Always confirm the ANSI/ISA 12.12.01 and CSA C22.2 N°213 hazardous location rating of your device before installing or using it in a hazardous location.
- To power on or power off a Industrial Personal Computer installed in a Class I, Division 2 hazardous location, you must either:
  - Use a switch located outside the hazardous environment, or
  - Use a switch certified for Class I, Division 1 operation inside the hazardous area.
- Do not disconnect equipment unless power has been switched off or the area is known to be non-hazardous. This applies to all connections including power, ground, serial, parallel, and network connections.
- Never use unshielded / ungrounded cables in hazardous locations.
- Use only non-incendive USB configuration.
- When enclosed, keep enclosure doors and openings closed at all times to avoid the accumulation of foreign matter inside the workstation.

**Failure to follow these instructions will result in death or serious injury.**

Division 2 hazardous location regulations require that all cable connections be provided with adequate strain relief and positive interlock. Use only non-incendive USB devices as USB connections do not provide adequate strain relief to allow the use of the Industrial Personal Computer's USB connections (*see page 99*). Never connect or disconnect a cable while power is applied at either end of the cable. All communication cables should include a chassis ground shield. This shield should include both copper braid and aluminum foil. The D-sub style connector housing must be a metal conductive type (e.g., molded zinc) and the ground shield braid must be terminated directly to the connector housing. Do not use a shield drain wire.

The outer diameter of the cable must be suited to the inner diameter of the cable connector strain relief so that a reliable degree of strain relief is maintained. Always secure the D-Sub connectors to the workstation-mating connectors via the two screws located on both sides.

## Operation and Maintenance

The systems have been designed for compliance with relevant spark ignition tests.

** DANGER**

**EXPLOSION HAZARD**

In addition to the other instructions in this manual, observe the following rules when installing the Industrial Personal Computer in a hazardous location:

- Wire the equipment in accordance with the National Electrical Code article 501.10(B) for Class I, Division 2 hazardous locations.
- Install the Industrial Personal Computer in an enclosure suitable for the specific application. IP65 enclosures are recommended even when not required by regulations.

**Failure to follow these instructions will result in death or serious injury.**

**NOTE:** IP65 are not part of UL certification for hazardous locations.



## Hazardous Location Installations - For ATEX

The assembled units with an enclosure should be marked:



II 3D

Ex tc IIIA T92°C Dc

Tamb: 0°C to +50°C

### DANGER

#### POTENTIAL FOR EXPLOSION

- Confirm that the location is free from explosively hazardous gases or dust before connecting or disconnecting equipment, replacing or wiring modules.
- The ambient temperature in protective enclosure must not exceed 50°C (refer to marking).
- Mounted in to the category 3D enclosures according to the directive 94/9/EC for atmosphere with dust.
- Modules must be mounted into protective enclosure that provides at least the following degree of protection:
  - IP54 for atmosphere with gas
  - IP6x for atmosphere with dust
- Do not open the protective enclosure while the system is powered up.
- Confirm that the power supply has been turned OFF before disconnecting, replacing or wiring modules.
- Ensure that the metal parts of component are properly connected to ground.
- Use only screw fasteners suitable for installations in explosive atmospheres.
- Do not use damaged equipment.

**Failure to follow these instructions will result in death or serious injury.**

## **Marine Installations - For Germanischer Lloyd (GL)**

The HDD-less DC powered type of the fan-less (Atom N270 embedded), 0-slot models (except for Stainless Steel Bezel Model) is GL certified only when connected to a Noise Filter for Marine Certification.

# Physical Overview

# 2

---

## Subject of this Chapter

This chapter provides a physical overview of the Industrial Personal Computer.

## What's in this Chapter?

This chapter contains the following topics:

Topic	Page
Package Contents	28
Industrial Personal Computer 15" - 0 slot Description	30
Industrial Personal Computer 15" - 1 slot Description	34
Industrial Personal Computer 15" - 2 slots Description	38
Industrial Personal Computer 19" - 0 slot Description	42
Industrial Personal Computer 19" - 1 slot Description	46
Industrial Personal Computer 19" - 2 slots Description	50
Industrial Personal Computer LED Description	54

## Package Contents

### Items

The following items are included in the package of the Industrial Personal Computer. Before using the Industrial Personal Computer, please confirm that all items listed here are present:

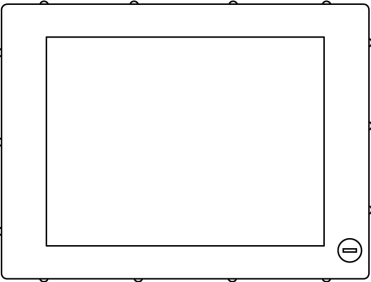
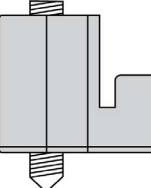
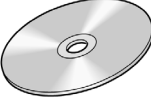
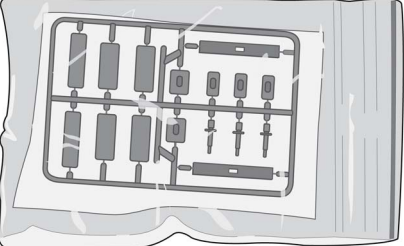
<p>Industrial Personal Computer: 1</p>	
<p>Installation Fasteners:</p> <ul style="list-style-type: none"> <li>● 14 per set for 15" Industrial Personal Computer</li> <li>● 18 per set for 19" Industrial Personal Computer</li> </ul>	
<p>Restore DVD-ROM containing the software required to reinstall the Operating System</p>	
<p>Documents</p>	<p>Warning/Caution Information (1)          The MS Windows EULA          PS4000 Series Installation Guide (1)</p>
<p>Connector Cover</p>	

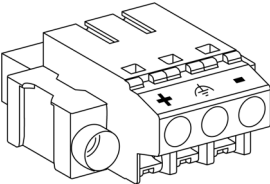
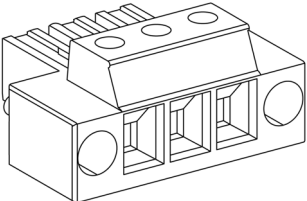
<p>DC Terminal Block (For the DC Industrial Personal Computer only)</p>	 A line drawing of a DC terminal block. It features a rectangular body with a circular port on the left side. The top surface has several screw terminals, with a '+' sign and a '-' sign indicating polarity. There are also three circular ports on the right side.
<p>AC Terminal Block (For the AC Industrial Personal Computer only)</p>	 A line drawing of an AC terminal block. It has a rectangular body with a circular port on the left side. The top surface has several screw terminals. The right side features three vertical slots for wire insertion and a circular port.

This Industrial Personal Computer has been carefully packed, with special attention to quality. However, should you find anything damaged or missing, contact your local distributor immediately.

## Industrial Personal Computer 15" - 0 slot Description

### Introduction

The following Industrial Personal Computer 15" - 0 slot description includes products for both AC and DC power supplies.

During operation, surface temperatures of the heat sink may reach 70 °C (158 °F).

### **⚠ WARNING**

#### **RISK OF BURN**

Do not touch the surface of the heat sink during operation.

**Failure to follow these instructions can result in death, serious injury, or equipment damage.**

### Front View

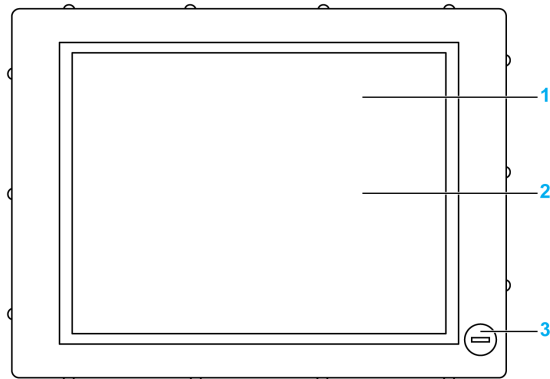

- 1 Display
- 2 Touch panel
- 3 USB5 (max. 1 A) (except for Stainless Steel Bezel Model)

### **NOTICE**

#### **UNINTENDED EQUIPMENT OPERATION**

- Always keep the cover in place during normal operation.

**Failure to follow these instructions can result in equipment damage.**

### Rear View of the DC Industrial Personal Computer

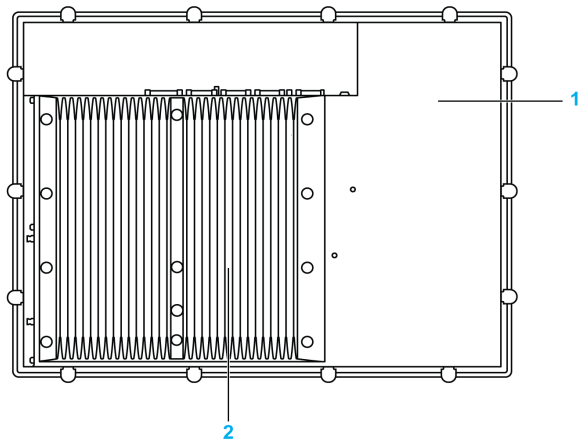

- 1 Industrial Personal Computer cover
- 2 Heat sink

### Rear View of the AC Industrial Personal Computer

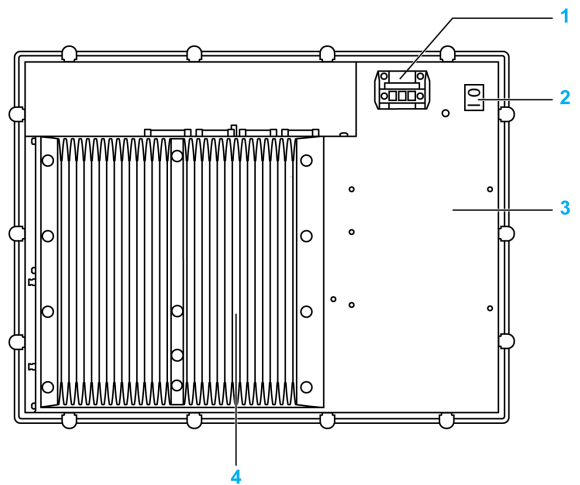

- 1 AC power connector (with AC terminal block)
- 2 Power switch
- 3 Industrial Personal Computer cover
- 4 Heat sink

### Right View

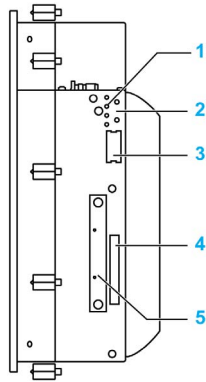

- 1 Status LEDs (*page. 54*)
- 2 Power/Reset button
- 3 Battery
- 4 Compact Flash slot CF1/Connection via IDE-PATA
- 5 Slide in Disk

### Bottom View

The following figure shows the bottom of the Core 2 Duo P8400 Pre-installed Model:

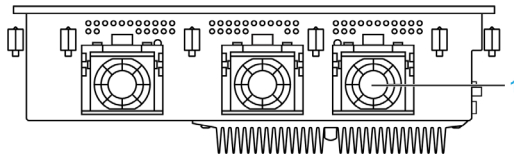

- 1 Fans (depending on references)

**NOTE:** The cooling method for the Atom N270 Pre-installed Model is passive heat sink.

### Top View of the DC Industrial Personal Computer

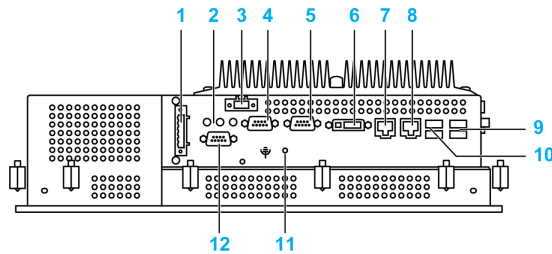

- 1 UPS Interface Board (depending on references)
- 2 MIC, Line IN, Line out
- 3 DC power connector
- 4 COM2
- 5 COM1
- 6 Monitor/Panel, DVI-I
- 7 ETH1 (10/100/1000 MBit)
- 8 ETH2 (10/100/1000 MBit)
- 9 USB1, USB3 (max. 1 A)
- 10 USB2, USB4 (max. 500 mA)
- 11 Ground connection
- 12 COM Expansion Board (depending on references)



## Top View of the AC Industrial Personal Computer

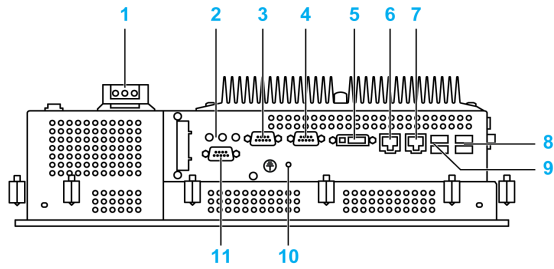

- 1 AC power connector
- 2 MIC, Line IN, Line out
- 3 COM2
- 4 COM1
- 5 Monitor/Panel, DVI-I
- 6 ETH1 (10/100/1000 MBit)
- 7 ETH2 (10/100/1000 MBit)
- 8 USB1, USB3 (max. 1 A)
- 9 USB2, USB4 (max. 500 mA)
- 10 Ground connection
- 11 COM Expansion Board (depending on references)

## Industrial Personal Computer 15" - 1 slot Description

### Introduction

The following Industrial Personal Computer 15" - 1 slot description includes products for both AC and DC power supplies.

During operation, surface temperatures of the heat sink may reach 70 °C (158 °F).

### **⚠ WARNING**

#### **RISK OF BURN**

Do not touch the surface of the heat sink during operation.

**Failure to follow these instructions can result in death, serious injury, or equipment damage.**

### Front View

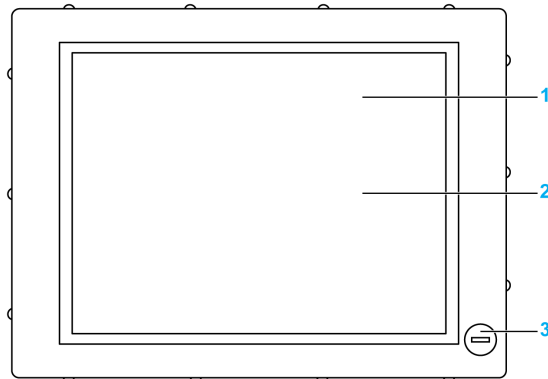

- 1 Display
- 2 Touch panel
- 3 USB5 (max. 1 A) (except for Stainless Steel Bezel Model)

### **NOTICE**

#### **UNINTENDED EQUIPMENT OPERATION**

- Always keep the cover in place during normal operation.

**Failure to follow these instructions can result in equipment damage.**

### Rear View of the DC Industrial Personal Computer

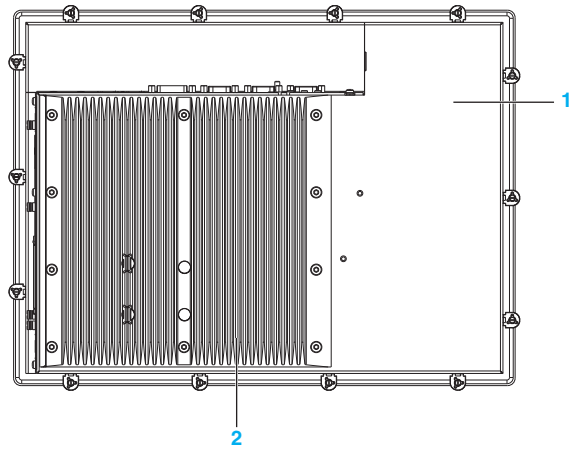

- 1 Industrial Personal Computer cover
- 2 Heat sink

### Rear View of the AC Industrial Personal Computer

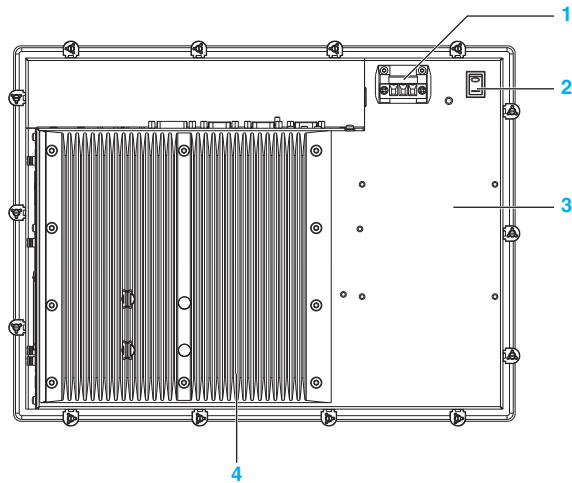

- 1 AC power connector (with AC terminal block)
- 2 Power switch
- 3 Industrial Personal Computer cover
- 4 Heat sink

**Right View**

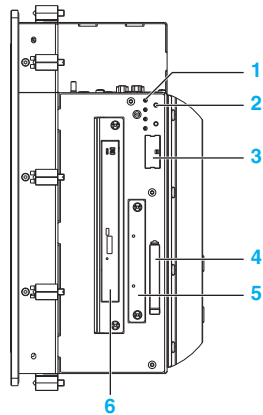

- 1 Status LEDs
- 2 Power/Reset button
- 3 Battery
- 4 Compact Flash slot CF1/Connection via IDE-PATA
- 5 Slide in Disk
- 6 Slide in Slot 1/Connection via SATA (depending on references)

**Bottom View**

The following figure shows the bottom of the Core 2 Duo P8400 Pre-installed Model:

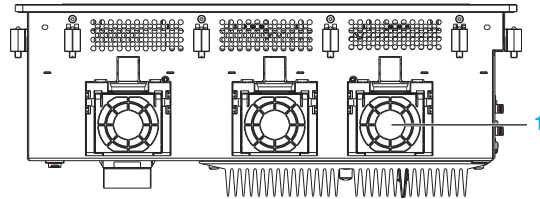

- 1 Fans (depending on references)

**NOTE:** The cooling method for the Atom N270 Pre-installed Model is passive heat sink.

**Top View of the DC Industrial Personal Computer**

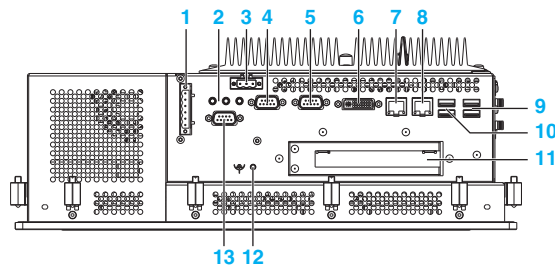

- 1 UPS Interface Board (depending on references)
- 2 MIC, Line IN, Line out
- 3 DC power connector
- 4 COM2
- 5 COM1
- 6 Monitor/Panel, DVI-I
- 7 ETH1 (10/100/1000 MBit)
- 8 ETH2 (10/100/1000 MBit)

- 9 USB1, USB3 (max.1 A)
- 10 Slot 1: PCI slot (half-size)
- 12 Ground connection
- 13 COM Expansion Board (depending on references)

### Top View of the AC Industrial Personal Computer

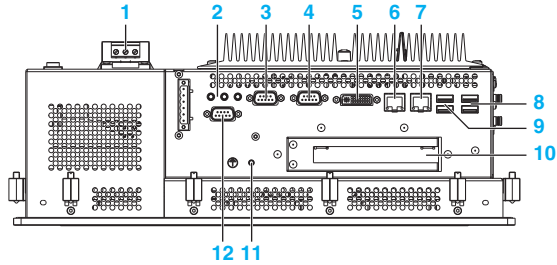

- 1 AC power connector
- 2 MIC, Line IN, Line out
- 3 COM2
- 4 COM1
- 5 Monitor/Panel, DVI-I
- 6 ETH1 (10/100/1000 MBit)
- 7 ETH2 (10/100/1000 MBit)
- 8 USB1, USB3 (max.1 A)
- 9 USB2, USB4 (max. 500 mA)
- 10 Slot 1: PCI slot (half-size)
- 11 Ground connection
- 12 COM Expansion Board (depending on references)

## Industrial Personal Computer 15" - 2 slots Description

### Introduction

The following Industrial Personal Computer 15" - 2 slot description includes products for both AC and DC power supplies.

During operation, surface temperatures of the heat sink may reach 70 °C (158 °F).

<b>⚠ WARNING</b>
<b>RISK OF BURN</b> Do not touch the surface of the heat sink during operation. <b>Failure to follow these instructions can result in death, serious injury, or equipment damage.</b>

### Front View

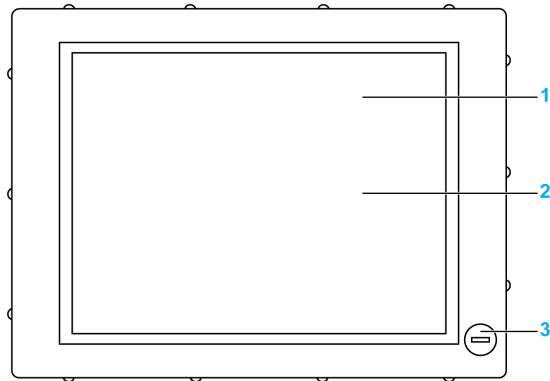

- 1 Display
- 2 Touch panel
- 3 USB5 (max. 1 A) (except for Stainless Steel Bezel Model)

<b>NOTICE</b>
<b>UNINTENDED EQUIPMENT OPERATION</b> <ul style="list-style-type: none"><li>• Always keep the cover in place during normal operation.</li></ul> <b>Failure to follow these instructions can result in equipment damage.</b>

### Rear View of the DC Industrial Personal Computer

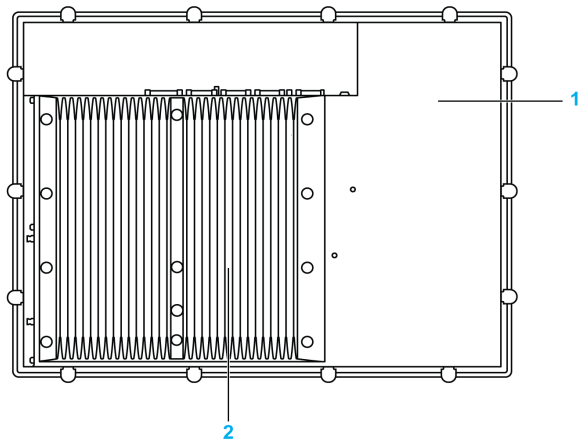

- 1 Industrial Personal Computer cover
- 2 Heat sink

### Rear View of the AC Industrial Personal Computer

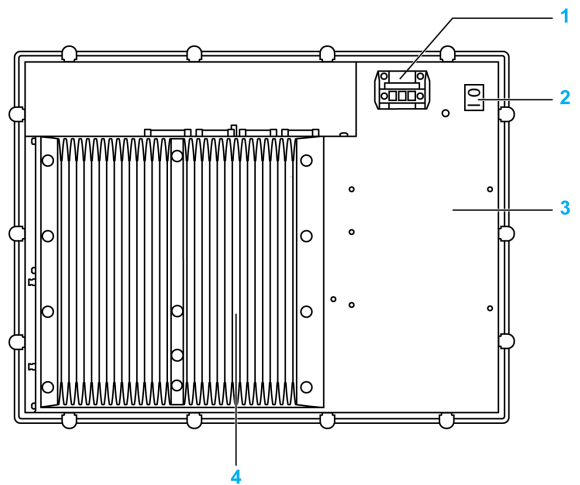

- 1 AC power connector (with AC terminal block)
- 2 Power switch
- 3 Industrial Personal Computer cover
- 4 Heat sink

**Right View**

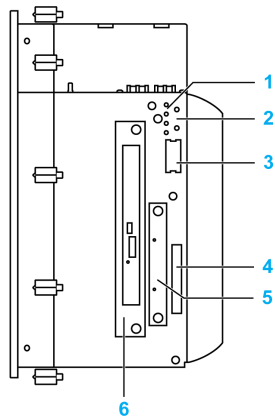

- 1 Status LEDs
- 2 Power/Reset button
- 3 Battery
- 4 Compact Flash slot CF1/Connection via IDE-PATA
- 5 Slide in Disk
- 6 Slide in Slot 1/Connection via SATA (depending on references)

**Bottom View**

The following figure shows the bottom of the Core 2 Duo P8400 Pre-installed Model:

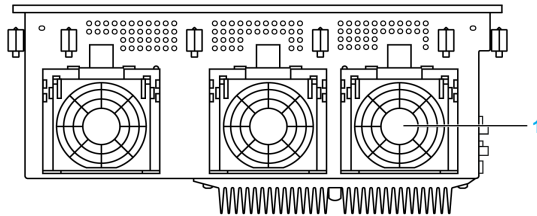

- 1 Fans (depending on references)

**NOTE:** The cooling method for the Atom N270 Pre-installed Model is passive heat sink.

**Top View of the DC Industrial Personal Computer**

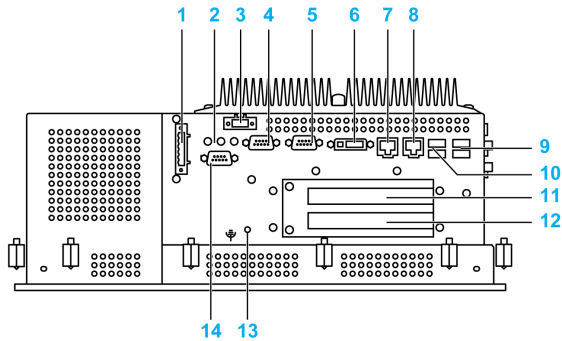

- 1 UPS Interface Board (depending on references)
- 2 MIC, Line IN, Line out
- 3 DC power connector
- 4 COM2



- 5 COM1
- 6 Monitor/Panel, DVI-I
- 7 ETH1 (10/100/1000 MBit)
- 8 ETH2 (10/100/1000 MBit)
- 9 USB1, USB3 (max. 1 A)
- 10 USB2, USB4 (max. 500 mA)
- 11 Slot 1: PCI slot (half-size)/PCI or PCIe
- 12 Slot 2: PCI slot (half-size)/PCI or PCIe
- 13 Ground connection
- 14 COM Expansion Board (depending on references)

### Top View of the AC Industrial Personal Computer

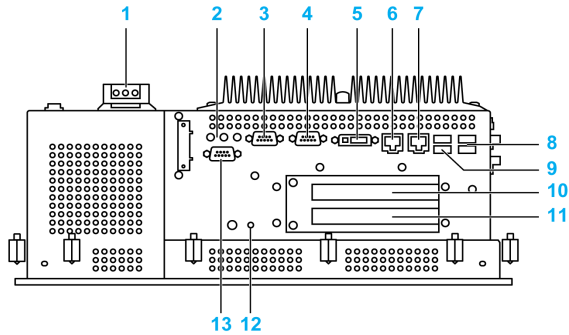

- 1 AC power connector
- 2 MIC, Line IN, Line out
- 3 COM2
- 4 COM1
- 5 Monitor/Panel, DVI-I
- 6 ETH1 (10/100/1000 MBit)
- 7 ETH2 (10/100/1000 MBit)
- 8 USB1, USB3 (max. 1 A)
- 9 USB2, USB4 (max. 500 mA)
- 10 Slot 1: PCI slot (half-size)/PCI or PCIe
- 11 Slot 2: PCI slot (half-size)/PCI or PCIe
- 12 Ground connection
- 13 COM Expansion Board (depending on references)

## Industrial Personal Computer 19" - 0 slot Description

### Introduction

The following Industrial Personal Computer 19" - 0 slot description includes products for both AC and DC power supplies.

During operation, surface temperatures of the heat sink may reach 70 °C (158 °F).

### **⚠ WARNING**

#### **RISK OF BURN**

Do not touch the surface of the heat sink during operation.

**Failure to follow these instructions can result in death, serious injury, or equipment damage.**

### Front View

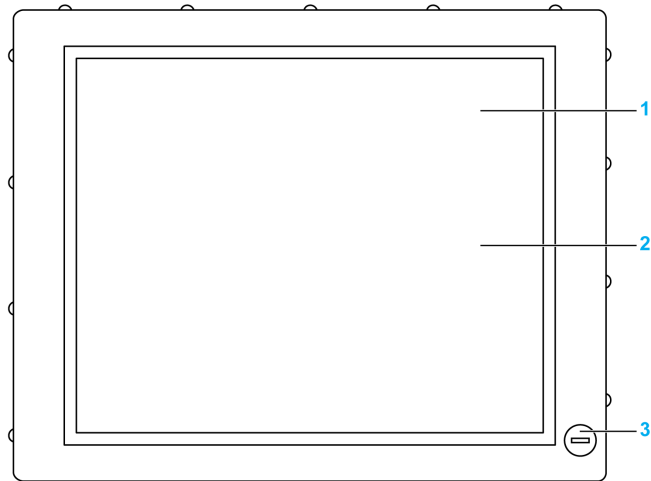

- 1 Display
- 2 Touch panel
- 3 USB5 (max. 1 A)

### **NOTICE**

#### **UNINTENDED EQUIPMENT OPERATION**

- Always keep the cover in place during normal operation.

**Failure to follow these instructions can result in equipment damage.**

### Rear View of the DC Industrial Personal Computer

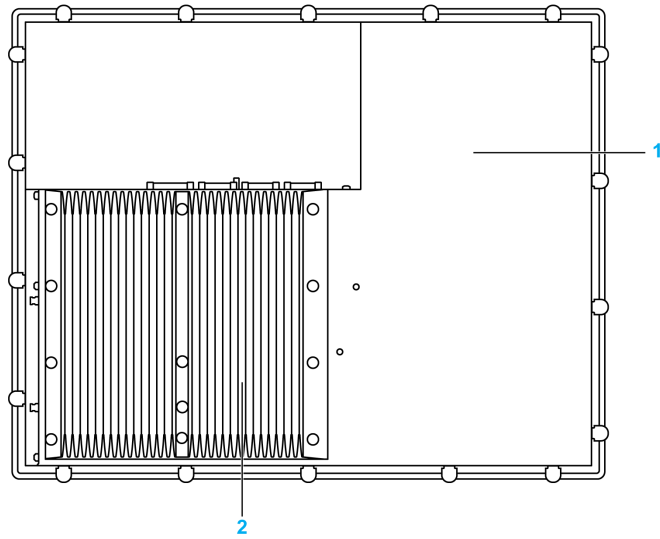

- 1 Industrial Personal Computer cover
- 2 Heat sink

### Rear View of the AC Industrial Personal Computer

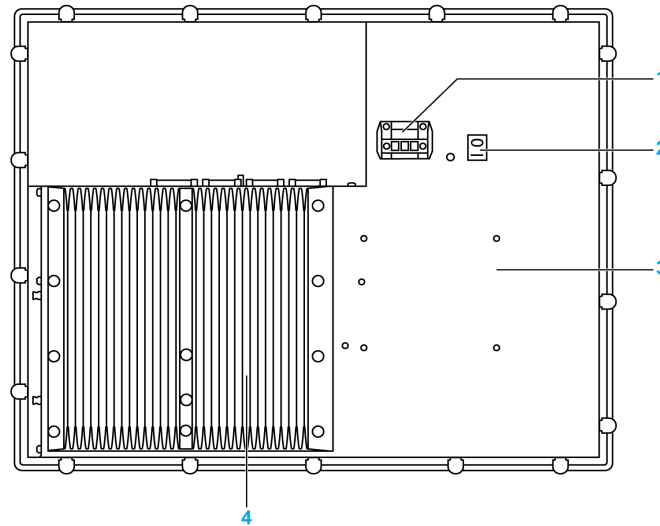

- 1 AC power connector (with AC terminal block)
- 2 Power switch
- 3 Industrial Personal Computer cover
- 4 Heat sink

**Right View**

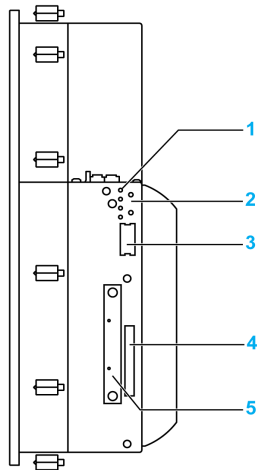

- 1 Status LEDs
- 2 Power/Reset button
- 3 Battery
- 4 Compact Flash slot CF1/Connection via IDE-PATA
- 5 Slide in Disk

**Bottom View**

The following figure shows the bottom of the Core 2 Duo P8400 Pre-installed Model:

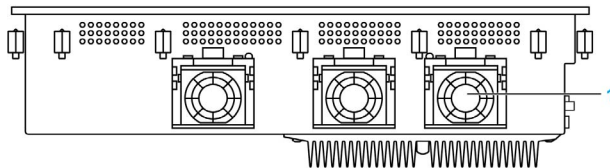

- 1 Fans (depending on references)

**NOTE:** The cooling method for the Atom N270 Pre-installed Model is passive heat sink.

**Top View the DC Industrial Personal Computer**

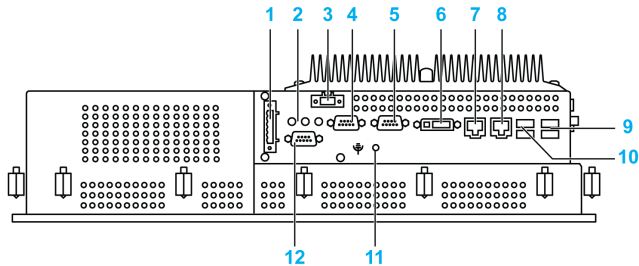

- 1 UPS Interface Board (depending on references)
- 2 MIC, Line IN, Line out
- 3 DC power connector
- 4 COM2
- 5 COM1
- 6 Monitor/Panel, DVI-I
- 7 ETH1 (10/100/1000 MBit)
- 8 ETH2 (10/100/1000 MBit)

- 9 USB1, USB3 (max.1 A)
- 10 USB2, USB4 (max. 500 mA)
- 11 Ground connection
- 12 COM Expansion Board (depending on references)

### Top View the AC Industrial Personal Computer

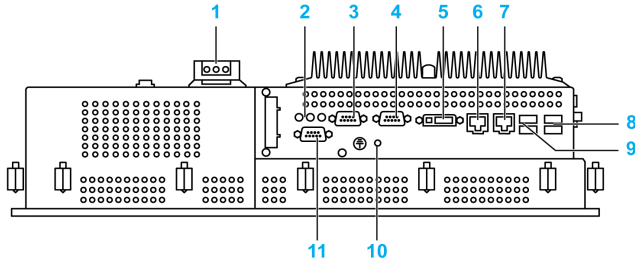

- 1 AC power connector
- 2 MIC, Line IN, Line out
- 3 COM2
- 4 COM1
- 5 Monitor/Panel, DVI-I
- 6 ETH1 (10/100/1000 MBit)
- 7 ETH2 (10/100/1000 MBit)
- 8 USB1, USB3 (max.1 A)
- 9 USB2, USB4 (max. 500 mA)
- 10 Ground connection
- 11 COM Expansion Board (depending on references)

## Industrial Personal Computer 19" - 1 slot Description

### Introduction

The following Industrial Personal Computer 19" - 1 slot description includes products for both AC and DC power supplies.

During operation, surface temperatures of the heat sink may reach 70 °C (158 °F).

### **⚠ WARNING**

#### **RISK OF BURN**

Do not touch the surface of the heat sink during operation.

**Failure to follow these instructions can result in death, serious injury, or equipment damage.**

### Front View

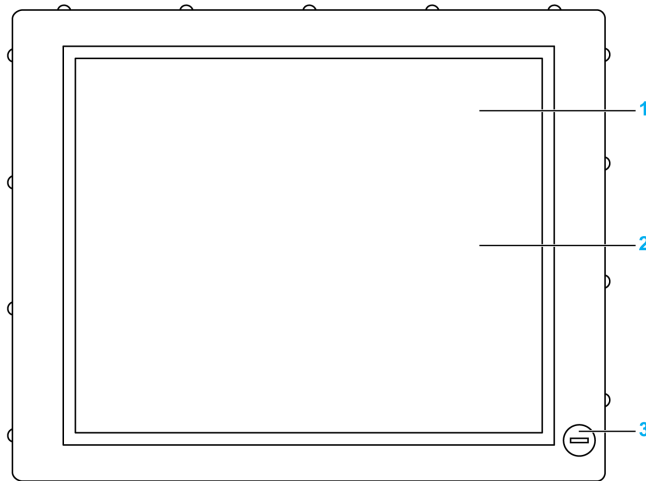

- 1 Display
- 2 Touch panel
- 3 USB5 (max. 1 A)

### **NOTICE**

#### **UNINTENDED EQUIPMENT OPERATION**

- Always keep the cover in place during normal operation.

**Failure to follow these instructions can result in equipment damage.**

### Rear View of the DC Industrial Personal Computer

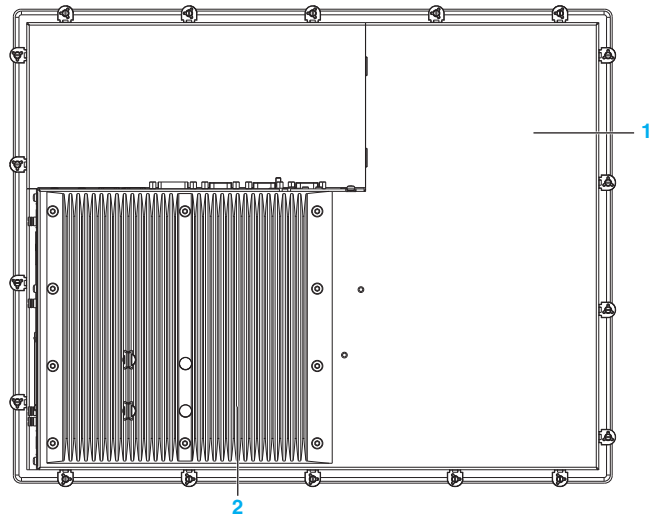

- 1 Industrial Personal Computer cover
- 2 Heat sink

### Rear View of the AC Industrial Personal Computer

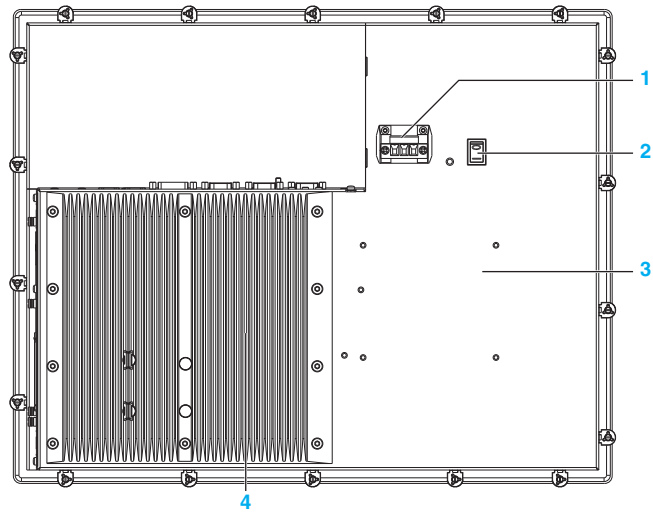

- 1 AC power connector (with AC terminal block)
- 2 Power switch
- 3 Industrial Personal Computer cover
- 4 Heat sink

**Right View**

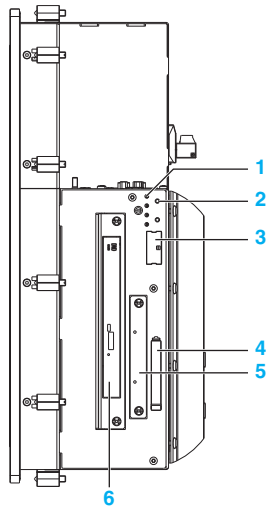

- 1 Status LEDs
- 2 Power/Reset button
- 3 Battery
- 4 Compact Flash slot CF1/Connection via IDE-PATA
- 5 Slide in Disk
- 6 Slide in Slot 1/Connection via SATA (depending on references)

**Bottom View**

The following figure shows the bottom of the Core 2 Duo P8400 Pre-installed Model:

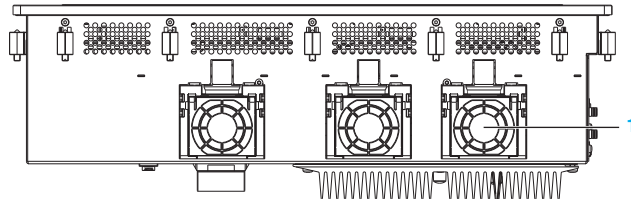

- 1 Fans (depending on references)

**NOTE:** The cooling method for the Atom N270 Pre-installed Model is passive heat sink.

**Top View the DC Industrial Personal Computer**

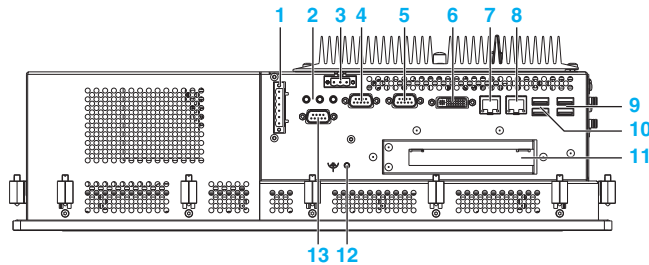

- 1 UPS Interface Board (depending on references)
- 2 MIC, Line IN, Line out
- 3 DC power connector
- 4 COM2
- 5 COM1



- 6 Monitor/Panel, DVI-I
- 7 ETH1 (10/100/1000 MBit)
- 8 ETH2 (10/100/1000 MBit)
- 9 USB1, USB3 (max. 1 A)
- 10 USB2, USB4 (max. 500 mA)
- 11 Slot 1: PCI slot (half-size)
- 12 Ground connection
- 13 COM Expansion Board (depending on references)

### Top View the AC Industrial Personal Computer

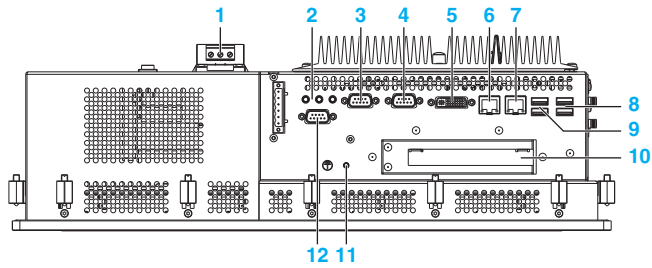

- 1 AC power connector
- 2 MIC, Line IN, Line out
- 3 COM2
- 4 COM1
- 5 Monitor/Panel, DVI-I
- 6 ETH1 (10/100/1000 MBit)
- 7 ETH2 (10/100/1000 MBit)
- 8 USB1, USB3 (max. 1 A)
- 9 USB2, USB4 (max. 500 mA)
- 10 Slot 1: PCI slot (half-size)
- 11 Ground connection
- 12 COM Expansion Board (depending on references)

## Industrial Personal Computer 19" - 2 slots Description

### Introduction

The following Industrial Personal Computer 19" - 2 slot description includes products for both AC and DC power supplies.

During operation, surface temperatures of the heat sink may reach 70 °C (158 °F).

### **⚠ WARNING**

#### **RISK OF BURN**

Do not touch the surface of the heat sink during operation.

**Failure to follow these instructions can result in death, serious injury, or equipment damage.**

### Front View

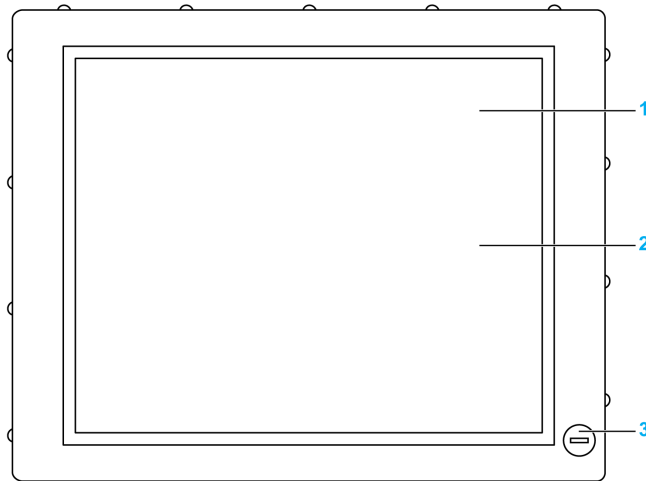

- 1 Display
- 2 Touch panel
- 3 USB5 (max. 1 A)

### **NOTICE**

#### **UNINTENDED EQUIPMENT OPERATION**

- Always keep the cover in place during normal operation.

**Failure to follow these instructions can result in equipment damage.**

### Rear View of the DC Industrial Personal Computer

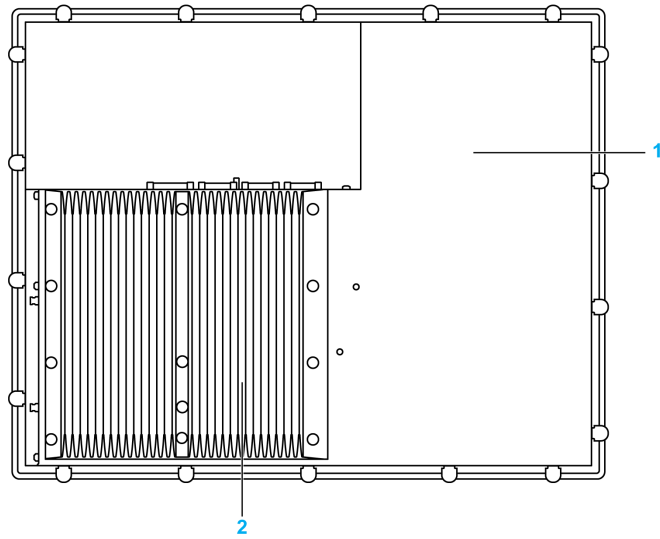

- 1 Industrial Personal Computer cover
- 2 Heat sink

### Rear View of the AC Industrial Personal Computer

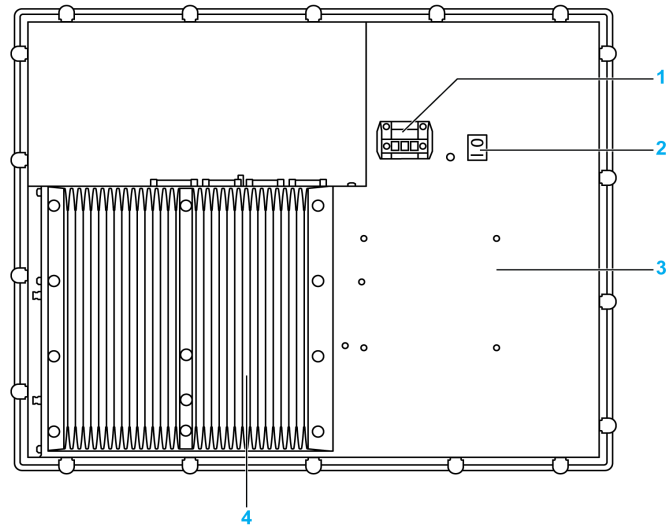

- 1 AC power connector (with AC terminal block)
- 2 Power switch
- 3 Industrial Personal Computer cover
- 4 Heat sink

**Right View**

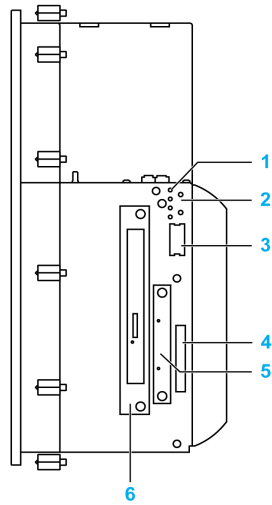

- 1 Status LEDs
- 2 Power/Reset button
- 3 Battery
- 4 Compact Flash slot CF1/Connection via IDE-PATA
- 5 Slide in Disk
- 6 Slide in Slot 1/Connection via SATA (depending on references)

**Bottom View**

The following figure shows the bottom of the Core 2 Duo P8400 Pre-installed Model:

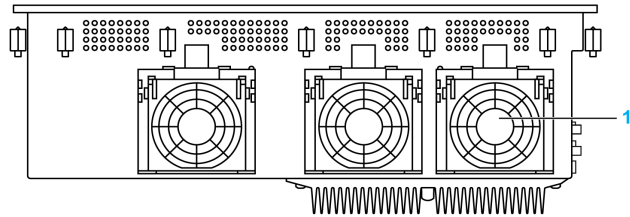

- 1 Fans (depending on references)

**NOTE:** The cooling method for the Atom N270 Pre-installed Model is passive heat sink.

**Top View the DC Industrial Personal Computer**

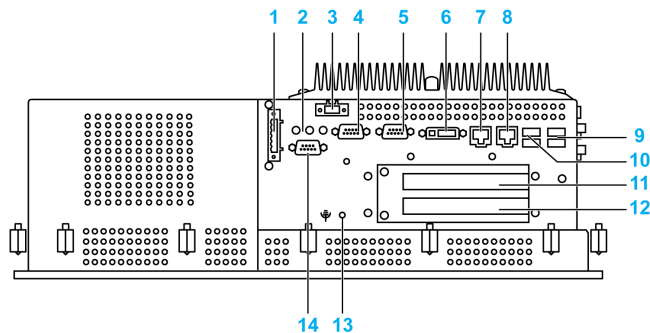

- 1 UPS Interface Board (depending on references)

- 2 MIC, Line IN, Line out
- 3 DC power connector
- 4 COM2
- 5 COM1
- 6 Monitor/Panel, DVI-I
- 7 ETH1 (10/100/1000 MBit)
- 8 ETH2 (10/100/1000 MBit)
- 9 USB1, USB3 (max. 1 A)
- 10 USB2, USB4 (max. 500 mA)
- 11 Slot 1: PCI slot (half-size) /PCI or PCIe
- 12 Slot 2: PCI slot (half-size) /PCI or PCIe
- 13 Ground connection
- 14 COM Expansion Board (depending on references)

### Top View the AC Industrial Personal Computer

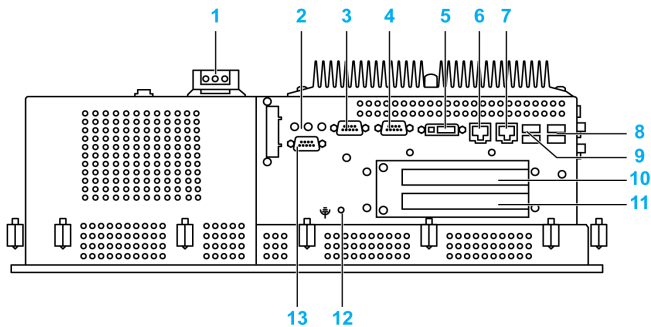

- 1 AC power connector
- 2 MIC, Line IN, Line out
- 3 COM2
- 4 COM1
- 5 Monitor/Panel, DVI-I
- 6 ETH1 (10/100/1000 MBit)
- 7 ETH2 (10/100/1000 MBit)
- 8 USB1, USB3 (max. 1 A)
- 9 USB2, USB4 (max. 500 mA)
- 10 Slot 1: PCI slot (half-size) /PCI or PCIe
- 11 Slot 2: PCI slot (half-size) /PCI or PCIe
- 12 Ground connection
- 13 COM Expansion Board (depending on references)

## Industrial Personal Computer LED Description

### LED Description

The following figure shows the LEDs on the Industrial Personal Computer:

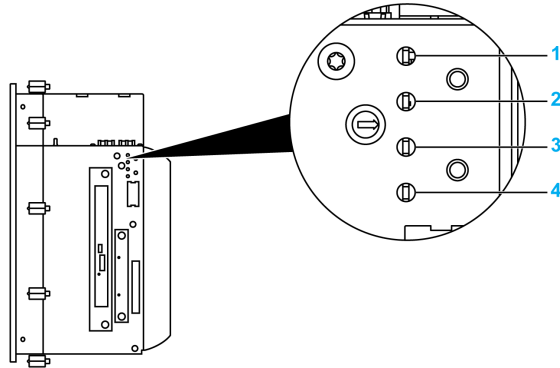

- 1 **[Power]** LED
- 2 **[Disk]** LED
- 3 **[RUN]** (Not supported)
- 4 **[Link]** (Not supported)

### Status LED

The following table describes the meaning of the status LEDs on the Industrial Personal Computer:

LED	Color	State	Meaning
<b>[Power]</b>	Green	On	Supply voltage is OK.
	Red	On	The system is in standby mode (S5: soft-off mode or S4: hibernate mode - Suspend-to-Disk).
	Orange <sup>(1)</sup>	On	Supply voltage is not OK. The system is operating on battery power.
<b>[Disk]</b>	Yellow	On	Indicates IDE drive access (CF, HDD, CD and so on).
<b>[RUN]</b>	-	-	Not supported
<b>[Link]</b>	-	-	Not supported

<sup>(1)</sup> Only lit when UPS battery unit is installed.

# Characteristics

# 3

---

## Subject of this Chapter

This chapter lists the product characteristics.

## What's in this Chapter?

This chapter contains the following topics:

Topic	Page
Industrial Personal Computer Characteristics	56
Industrial Personal Computer Interface Characteristics	60
Environmental Characteristics	61

## Industrial Personal Computer Characteristics

### Product Characteristics

Element		Atom N270 Pre-installed Model			Core2Duo P8400 Pre-installed Model		
		Characteristics			Characteristics		
		AtomN270 0 slot	AtomN270 1 slot	AtomN270 2 slots	Core2Duo P8400 0 slot	Core2Duo P8400 1 slot	Core2Duo P8400 2 slots
Expansion Slots		None	1 PCI	•1 PCI +1 PCIe •2 PCI	None	1 PCI	•1 PCI +1 PCIe •2 PCI
Processor		AtomN270 1.6 GHz 512 KB L2 cache			Core2Duo P8400 2.26 GHz 3 MB L2 cache		
Intel Chipset		945GME			GM45		
Cooling Method		Passive heat sink, Fanless operation			Passive heat sink and Fan kit with filter Fan speed is controlled by internal temperature. Fan does not operate unless internal temperature reaches the set temperature.		
RAM		DDR2 533 MHz SO-DIMM 2 slots 1 GB to 3 GB max (Unable to be added by Users.)			DDR3 1066 MHz SO-DIMM 2 slots 2 GB to 8 GB max (Unable to be added by Users.)		
Graphics	Controller	Intel® Graphics Media Accelerator 950			Intel® Graphics Media Accelerator (GMA) 4500 MHD		
	Video Memory	Up to 224 MB (reserved from main memory)			Up to 384 MB (reserved from main memory)		
	Color Depth	32 bit (maximum)			32 bit (maximum)		
	RGB Resolution	up to 2048 x 1536 @ 70Hz			up to 2048 x 1536 @ 70Hz		
	DVI Resolution	up to 1920 x 1080			up to 1920 x 1080		
Slide in Disk		1 slot equipped • HDD or SSD			1 slot equipped • HDD or SSD		
Compact Flash		TYPE-I 1SLOT • CF Card 4 GB			TYPE-I 1SLOT • CF Card 4 GB, or CF Card 8GB		
Slide in Slot		None	1 slot equipped with: • DVD-RW • HDD, SSD and Slide-in Slot Adapter unit also available		None	1 slot equipped with: • DVD-RW • HDD, SSD and Slide-in Slot Adapter unit also available	
Reset Button		Yes			Yes		
Buzzer		Yes			Yes		
Front Bezel Material		Aluminum or stainless steel (JIS SUS 304, EN 1.4301)					
15" Industrial Personal Computer Weight	AC Model*1	Approx. 7.5 kg (16.5 lbs)	Approx. 8.0 kg (17.6 lbs)	Approx. 8.1 kg (17.9 lbs)	Approx. 8.5 kg (18.7 lbs)	Approx. 8.8 kg (19.4 lbs)	Approx. 9.0 kg (19.8 lbs)
	DC Model*1	Approx. 7.0 kg (15.4 lbs)	Approx. 7.5 kg (16.5 lbs)	Approx. 8.0 kg (17.6 lbs)	Approx. 8.0 kg (17.6 lbs)	Approx. 8.5 kg (18.7 lbs)	Approx. 9.0 kg (19.8 lbs)



Element		Atom N270 Pre-installed Model			Core2Duo P8400 Pre-installed Model		
		Characteristics			Characteristics		
		AtomN270 0 slot	AtomN270 1 slot	AtomN270 2 slots	Core2Duo P8400 0 slot	Core2Duo P8400 1 slot	Core2Duo P8400 2 slots
19" Industrial Personal Computer Weight	AC Model	Approx. 11.5 kg (25.4 lbs)	Approx. 11.6 kg (25.6 lbs)	Approx. 12.0 kg (26.5 lbs)	Approx. 12.5 kg (27.6 lbs)	Approx. 12.6 kg (27.8 lbs)	Approx. 13.0 kg (28.7 lbs)
	DC Model	Approx. 11.0 kg (24.3 lbs)	Approx. 11.5 kg (25.4 lbs)	Approx. 12.0 kg (26.5 lbs)	Approx. 11.5 kg (25.4 lbs)	Approx. 12.0 kg (26.5 lbs)	Approx. 12.5 kg (27.6 lbs)

\*1 The Stainless Steel Bezel Model is approximately 1.3 kg (2.9 lbs) heavier than the weights shown in the table.

## Display Characteristics

Element	15" Screen Size	19" Screen Size
Graphics	XGA TFT active matrix (1,024 x 768 pixels)	SXGA TFT active matrix (1,280 x 1,024 pixels)
Number of Colors	16 million	16 million
Brightness Control	Step less adjustment	Step less adjustment
Touch Sensitive Screen	Analog resistive film, resolution 4,096 x 4,096	Analog resistive film, resolution 4,096 x 4,096
Backlight	LED - Life span > 50,000 h @ 25 °C (77 °F)	LED - Life span > 50,000 h @ 25 °C (77 °F)

Multiple touch operation on the Industrial Personal Computer having analog-resistive touch panel may cause unexpected input around the center of touched positions.

 <b>WARNING</b>
<b>UNINTENDED EQUIPMENT OPERATION</b>
<ul style="list-style-type: none"> <li>Do not touch simultaneously more than two points on the Industrial Personal Computer.</li> </ul> <p><b>Failure to follow these instructions can result in death, serious injury, or equipment damage.</b></p>

**DC Power Supply**

Element	Characteristics
Rated Voltage	24 Vdc $\pm$ 25 %
Power Consumption	130 W (max.)
Rated Current	6 A max.
Inrush Current	Typically 7 A, max. 50 A < 300 $\mu$ s
Battery Backup UPS	Optional

**AC Power Supply**

Element	Characteristics
Rated Voltage	100...240 Vac
Power Consumption	130 W (max.)
Frequency	60/50 Hz
Rated Current	1.6 A max.
Inrush Current	[100VAC]:Typ. 20 A (At cold start) [240VAC]:Typ. 40 A (At cold start)

**Operating Systems**

	Atom N270 Pre-installed Model	Core 2 Duo P8400 Pre-installed Model
Operating System* <sup>1</sup>	HDD or SSD: Windows® XP Professional SP3 CF: Windows® Embedded Standard 2009	HDD or SSD: Windows® XP Professional SP3/Windows® 7 Ultimate CF* <sup>2</sup> : Windows® Embedded Standard 2009/Windows® Embedded Standard 7

\*1 For details on languages supported by pre-installed operating systems, read "The List of OS Pre-installed Languages for Multi-language" (see page 59).

\*2 The capacity of CF Card is 8GB only.

## The List of OS Pre-installed Languages for Multi-language

	Windows® XP Professional	Windows® 7 Ultimate	Windows® Embedded Standard 2009	Windows® Embedded Standard 7
Arabic	✓	✓	✓	*1
Bulgarian	✓	✓	—	*1
Chinese(Simplified)	✓	✓	✓	*1
Chinese(Traditional)	✓	✓	✓	*1
Croatian	✓	✓	—	*1
Czech	✓	✓	✓	*1
Danish	✓	✓	✓	*1
Dutch	✓	✓	✓	*1
English	✓	✓	✓	✓
Estonian	✓	✓	—	*1
Finnish	✓	✓	✓	*1
French	✓	✓	✓	✓
German	✓	✓	✓	✓
Greek	✓	✓	✓	*1
Hebrew	✓	✓	✓	*1
Hungarian	✓	✓	✓	*1
Italian	✓	✓	✓	✓
Japanese	✓	✓	✓	✓
Korean	✓	✓	✓	*1
Latvian	✓	—	—	*1
Lithuanian	✓	✓	—	*1
Norwegian	✓	✓	✓	*1
Polish	✓	✓	✓	*1
Portuguese	✓	✓	✓	*1
Portuguese(Brazil)	✓	✓	✓	*1
Romanian	✓	✓	—	*1
Russian	✓	✓	✓	*1
Serbian Latin	—	✓	—	*1
Slovak	✓	✓	—	*1
Slovenian	✓	✓	—	*1
Spanish	✓	✓	✓	✓
Swedish	✓	✓	✓	*1
Thai	✓	✓	—	*1
Turkish	✓	✓	✓	*1
Ukrainian	—	✓	—	*1

\*1 The languages can be downloaded from Pro-face website "Otasuke Pro!".  
<http://www.pro-face.com/otasuke/>

## Industrial Personal Computer Interface Characteristics

### Serial Interface

Element	Characteristics
Amount	2
Type	RS-232C, modem-capable, not electrically isolated
UART	16550-compatible, 16-byte FIFO
Transfer Rate	Maximum 115 kBit/s
Connection	D-Sub 9-pin, plug ( <i>see page 101</i> )

### USB Interface

Element	Characteristics
Type	USB 2.0
Amount	5 (4 for Stainless Steel Bezel Model)
Transfer Rate	Low speed (1.5 Mbit/s), full speed (12 Mbit/s), to high speed (480 Mbit/s)
Connection	Type A ( <i>see page 99</i> )
Current load	Maximum 500 mA per connection for USB2, USB4 Maximum 1 A per connection for USB1, USB3, USB5 (USB 1, USB 3 for Stainless Steel Bezel Model)

### Ethernet Interface

Element	Characteristics
Amount	2
Speed	10/100/1000 Mbit/s
Connection	RJ-45 Modular jack

**NOTE:** The serial, USB and Ethernet interfaces on this product have internal port numbers that may differ from their physical port numbers, such as "ETH1" or "USB1", printed on the product and used for identification in this manual. As the internal port number assigned to the interface differs between operating systems, please check the interface in your environment.

Ethernet Interface Example)	Physical port number on this product :	ETH1	ETH2
	Internal port number (Windows 7) :	LAN1	LAN2
	Internal port number (Windows XP) :	LAN2	LAN1

## Environmental Characteristics

### Characteristics

Characteristics	Value	Standards
Degree of Protection	IP65	EN/IEC 61131-2
Pollution Degree	For use in Pollution Degree 2 environment	EN/IEC 61131-2
Surrounding Air Temperature during Operation	0...50 °C (32...122 °F) *1	EN/IEC 61131-2, UL 508
Storage Temperature	- 20...+60 °C (- 4...+140 °F)	IEC 60068-2-2 tests Bb and Ab, IEC 60068-2-14 tests Na and EN/IEC 61131-2
Operating Altitude	2,000 m (6,560 ft) max	EN/IEC 61131-2
Vibration		IACS E10 and EN/IEC 60068-2-6 Fc
Operation (continuous) for products with SSD or CF Card storage device.	2...9 Hz: 1.5 mm 9...200 Hz: 4.9 m/s <sup>2</sup>	
	5...8.4 Hz: 1.75 mm 8.4...150 Hz: 4.9 m/s <sup>2</sup>	
Operation (continuous) for products with HDD storage device.	5...100 Hz: 1.225 m/s <sup>2</sup>	
Operation (occasional) for products with SSD or CF Card storage device	2...9 Hz: 3 mm 9...200 Hz: 9.8 m/s <sup>2</sup>	
	5...8.4 Hz: 3.5 mm 8.4...150 Hz: 9.8 m/s <sup>2</sup>	
Operation (occasional) for products with HDD storage device.	5...100 Hz: 2.450 m/s <sup>2</sup>	
Marine Certification (continuous)	3...13.2 Hz: 1 mm (0.04 in.) 13.2...100 Hz: 6.86 m/s <sup>2</sup>	
Shock Resistance (in operation)	147 m/s <sup>2</sup> for a duration of 11 ms	IEC 60068-2-27 Ea test
Surrounding Air Humidity during Operation	10...85 % RH (Wet bulb temperature: 29 °C (84.2 °F) max. - no condensation)	EN/IEC 60068-2-78 Cab
Storage Humidity	10...85 % RH (Wet bulb temperature: 29 °C (84.2 °F) max. - no condensation)	EN/IEC 60068-2-30 Db
Electromagnetic Compatibility (EMC)	Immunity to High Frequency Interference	EN/IEC 61131-2, IEC 61000-4-x
	Electromagnetic Emissions Class A	EN 55022, EN 55011

\*1 Surrounding air temperature depends on what feature or option you use.

When you use Panel IPC without FAN unit (AtomN270)

0...45 °C (32... 113 °F) when using Gigabit Ether

5...40 °C (41... 104 °F) when using Slide in Slot

When you use Industrial Personal Computer with FAN unit (Core2Duo P8400)

5...50 °C (41... 122 °F) when using Slide in Slot

**NOTE:** IEC 61131-2 and IP65 are not part of UL certification for hazardous locations.



## Dimensions/Assembly

# 4

---

### Subject of this Chapter

This chapter describes Industrial Personal Computer dimensions and installation panels.

### What's in this Chapter?

This chapter contains the following topics:

Topic	Page
Industrial Personal Computer 15" Dimensions	64
Industrial Personal Computer 19" Dimensions	71
Installation Requirements	78
Industrial Personal Computer Installation	82

## Industrial Personal Computer 15" Dimensions

**NOTE:** All dimensions shown in the outline diagrams are the same dimensions as the Stainless Steel Bezel Model.

### DC Industrial Personal Computer 15" - 0 Slot Dimensions

The following figure shows the dimensions of the DC Industrial Personal Computer 15" with 0 slot:

$\frac{\text{mm}}{\text{in.}}$

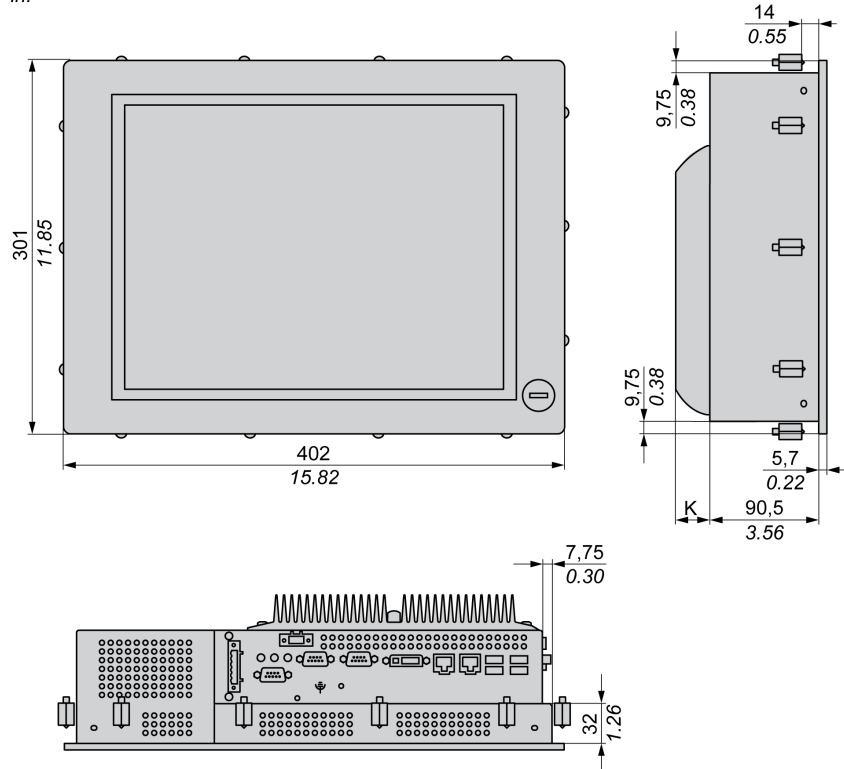

**NOTE:**

- Measurement "K" depends on which heat sink is used (see page 69).
- No front USB for Stainless Steel Bezel Model.



### DC Industrial Personal Computer 15" - 1 Slot Dimensions

The following figure shows the dimensions of the DC Industrial Personal Computer 15" with 1 slot:

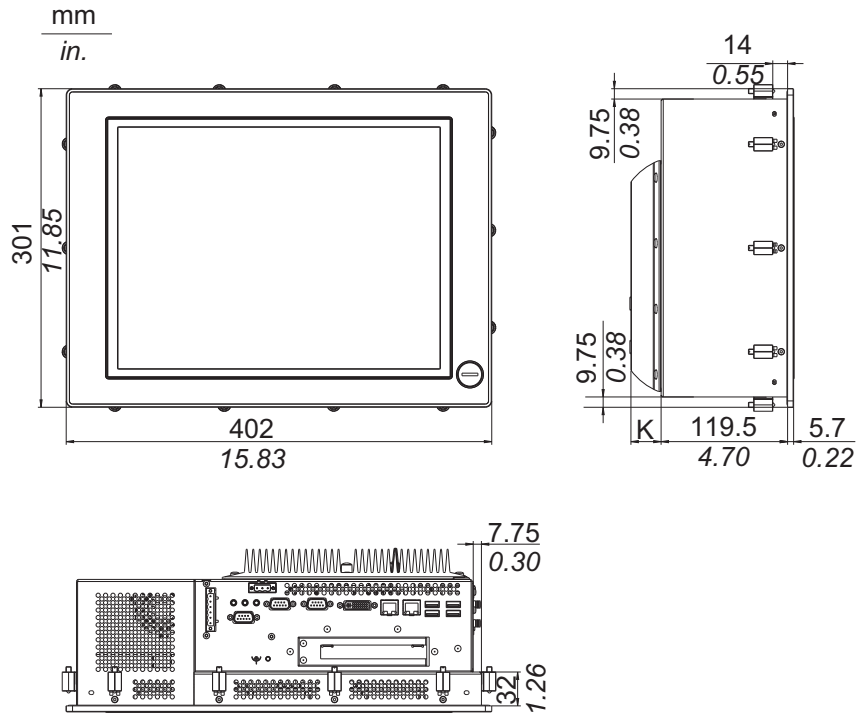

**NOTE:**

- Measurement "K" depends on which heat sink is used (see page 69).
- No front USB for Stainless Steel Bezel Model.

### DC Industrial Personal Computer 15" - 2 Slots Dimensions

The following figure shows the dimensions of the DC Industrial Personal Computer 15" with 2 slots:

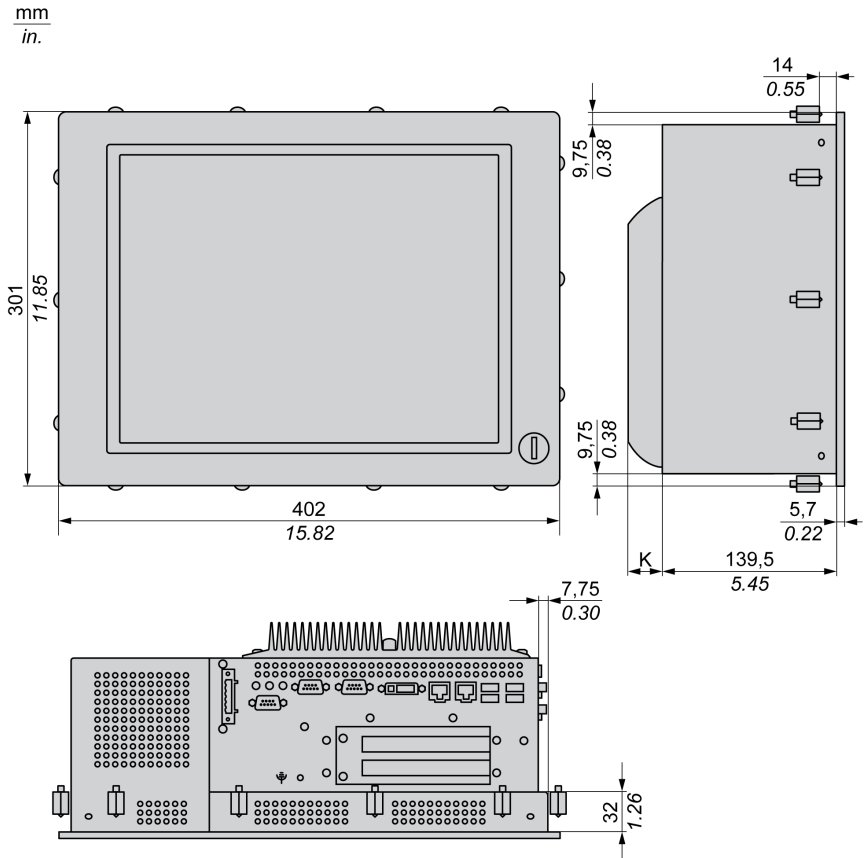

**NOTE:**

- Measurement "K" depends on which heat sink is used (see page 69).
- No front USB for Stainless Steel Bezel Model.

### AC Industrial Personal Computer 15" - 0 Slot Dimensions

The following figure shows the dimensions of the AC Industrial Personal Computer 15" with 0 slot:

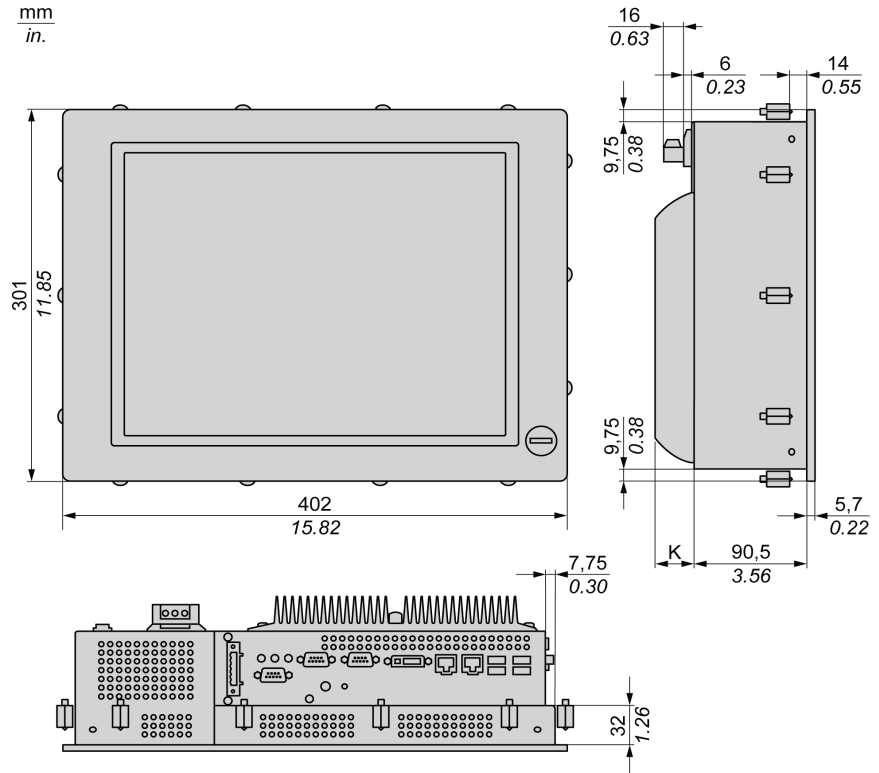

**NOTE:**

- Measurement "K" depends on which heat sink is used (see page 69).
- No front USB for Stainless Steel Bezel Model.

### AC Industrial Personal Computer 15" - 1 Slot Dimensions

The following figure shows the dimensions of the AC Industrial Personal Computer 15" with 1 slot:

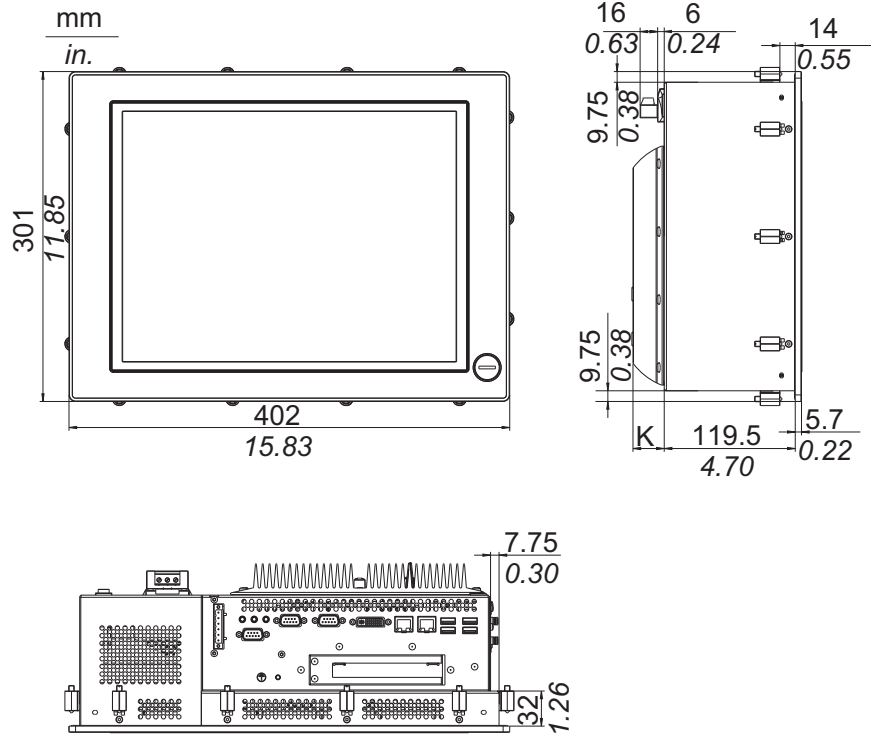

**NOTE:**

- Measurement "K" depends on which heat sink is used (see page 69).
- No front USB for Stainless Steel Bezel Model.

### AC Industrial Personal Computer 15" - 2 Slots Dimensions

The following figure shows the dimensions of the AC Industrial Personal Computer 15" with 2 slots:

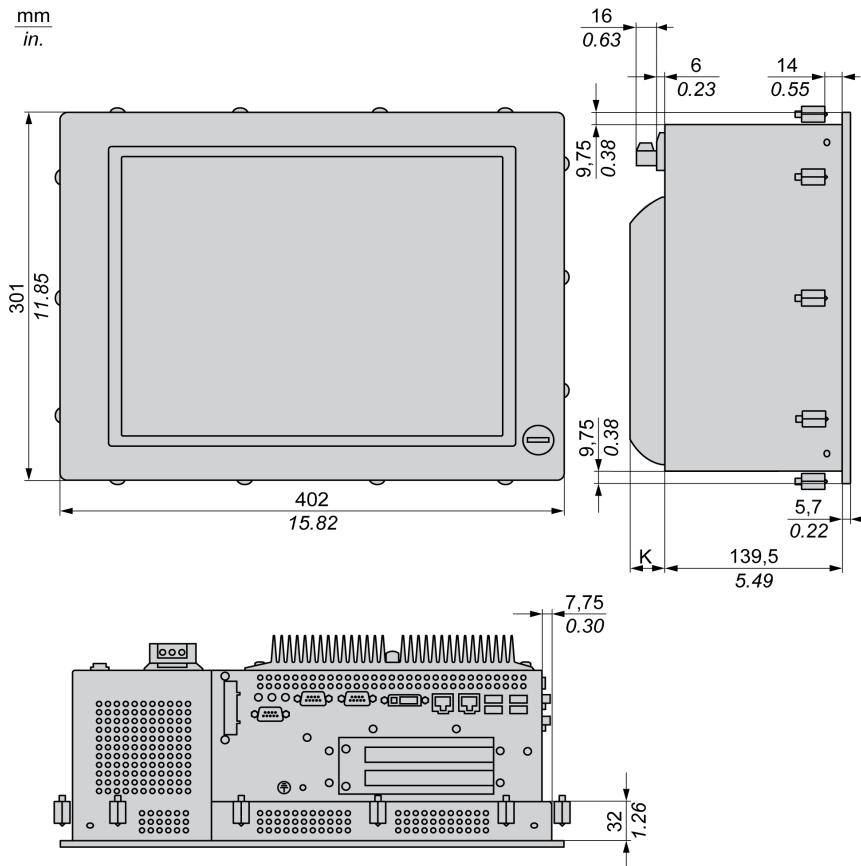

**NOTE:**

- Measurement “K” depends on which heat sink is used (see page 69).
- No front USB for Stainless Steel Bezel Model.

### Values

The following table provides the “K” measurement value depending on which heat sink is used:

Industrial Personal Computer Range	“K” Value
Core 2 Duo P8400 Pre-installed Model (0, 1 or 2 slots)	28 mm (1.103 in.)
Atom N270 Pre-installed Model (0, 1 or 2 slots)	12.8 mm (0.503 in.)

The following table shows the general tolerances for Industrial Personal Computer dimensions:

Nominal Measurement	General Tolerance acc. DIN ISO 2768 Medium
up to 6 mm (up to 0.236 in.)	± 0.1 mm (± 0.004 in.)
6...30 mm (0.236...1.181 in.)	± 0.2 mm (± 0.0078 in.)
30...120 mm (1.18...4.724 in.)	± 0.3 mm (± 0.012 in.)

<b>Nominal Measurement</b>	<b>General Tolerance acc. DIN ISO 2768 Medium</b>
120...400 mm (4.724...15.747 in.)	± 0.5 mm (± 0.02 in.)
400...1000 mm (15.747...39.37 in.)	± 0.8 mm (± 0.031 in.)

## Industrial Personal Computer 19" Dimensions

### DC Industrial Personal Computer 19" - 0 Slot Dimensions

The following figure shows the dimensions of the DC Industrial Personal Computer 19" with 0 slot:

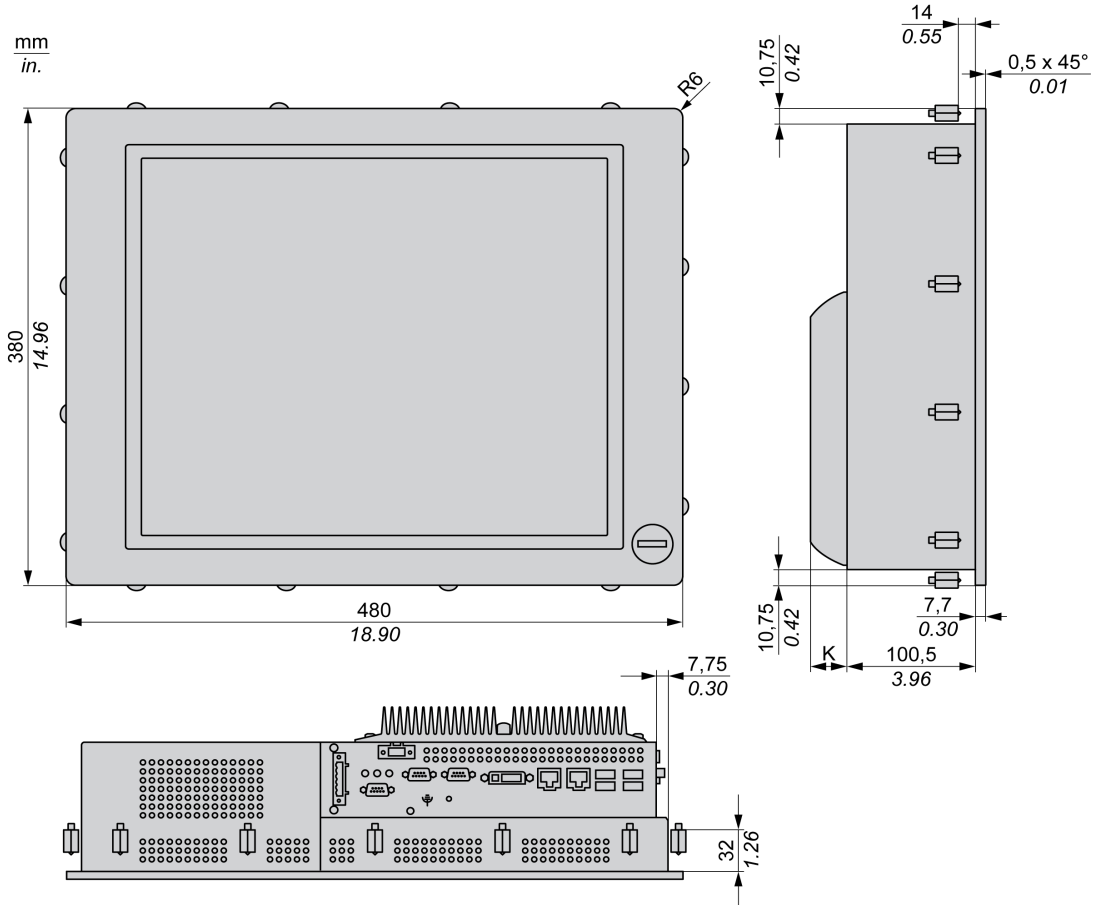

**NOTE:** Measurement "K" depends on which heat sink is used (see page 76).

**DC Industrial Personal Computer 19" - 1 Slot Dimensions**

The following figure shows the dimensions of the DC Industrial Personal Computer 19" with 1 slot:

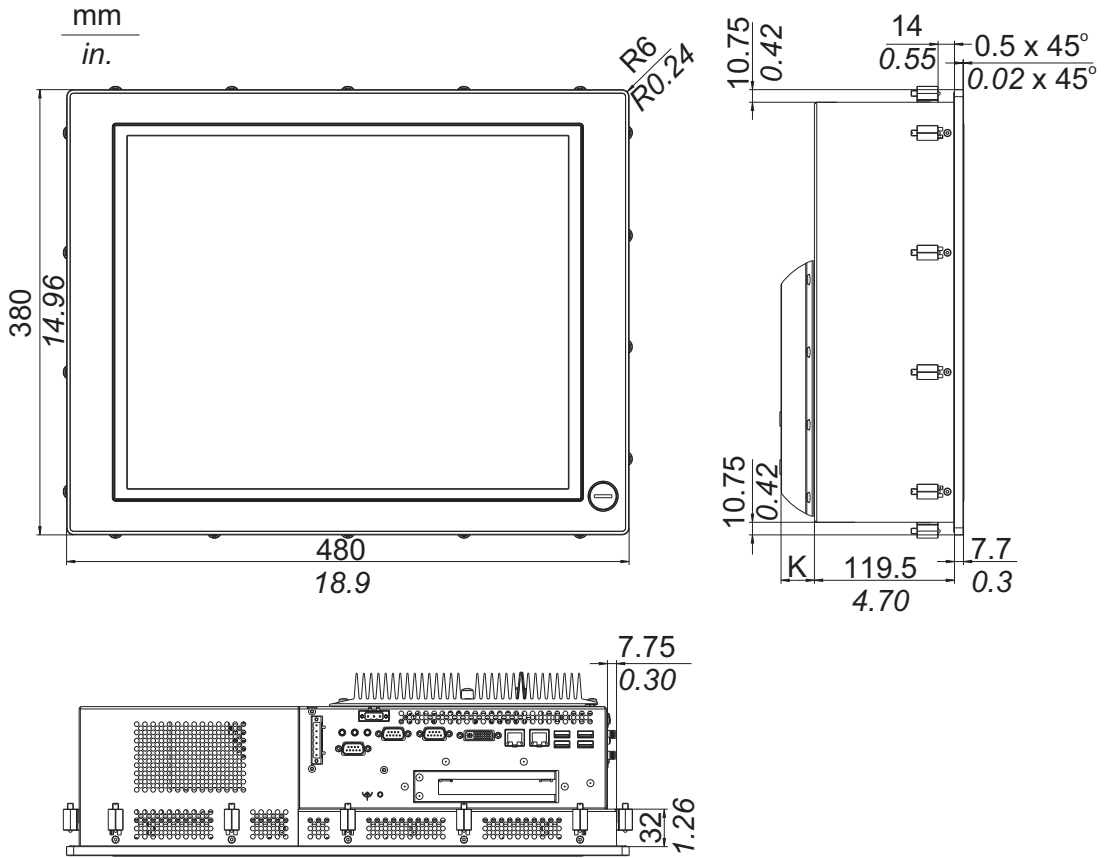

**NOTE:** Measurement "K" depends on which heat sink is used (see page 76).



### DC Industrial Personal Computer 19" - 2 Slots Dimensions

The following figure shows the dimensions of the DC Industrial Personal Computer 19" with 2 slots:

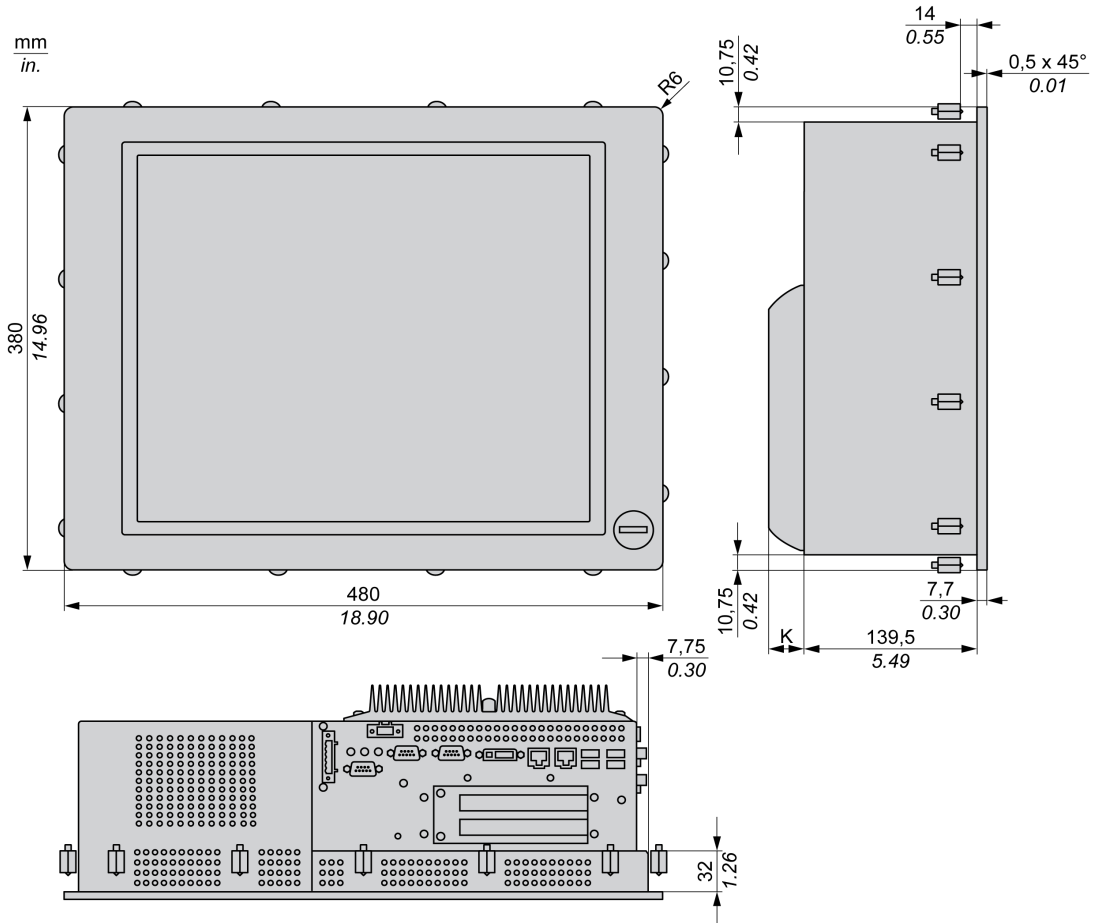

**NOTE:** Measurement "K" depends on which heat sink is used (see page 76).

**AC Industrial Personal Computer 19" - 0 Slot Dimensions**

The following figure shows the dimensions of the AC Industrial Personal Computer 19" with 0 slot:

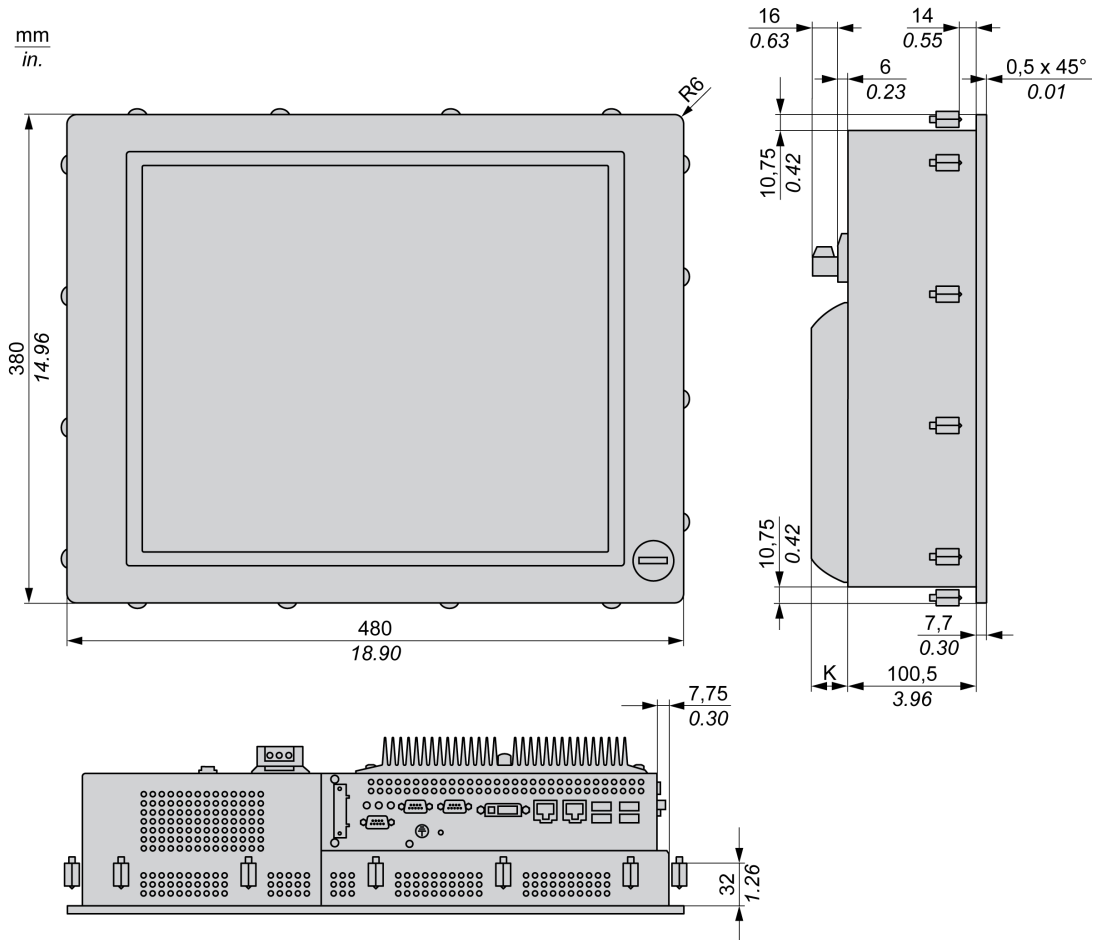

**NOTE:** Measurement "K" depends on which heat sink is used (see page 76).

### AC Industrial Personal Computer 19" - 1 Slot Dimensions

The following figure shows the dimensions of the AC Industrial Personal Computer 19" with 1 slot:

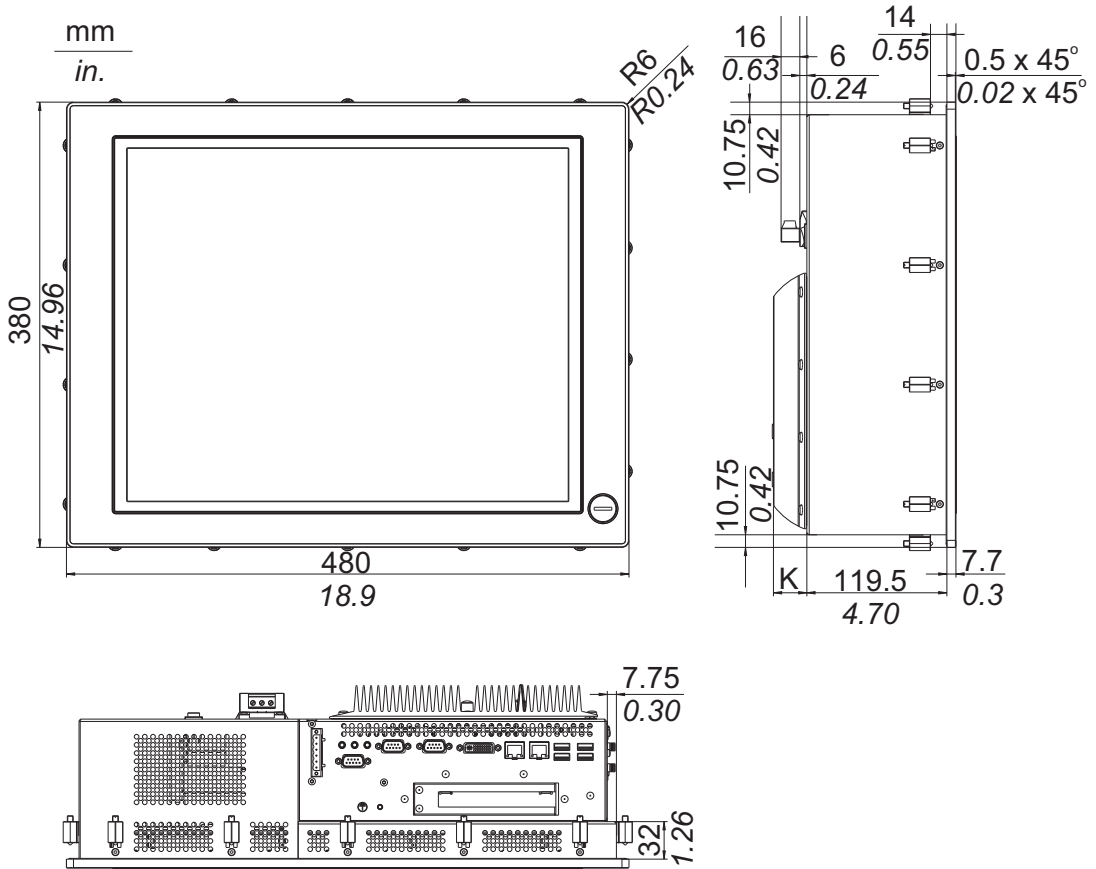

**NOTE:** Measurement "K" depends on which heat sink is used (see page 76).

**AC Industrial Personal Computer 19" - 2 Slots Dimensions**

The following figure shows the dimensions of the AC Industrial Personal Computer 19" with 2 slots:

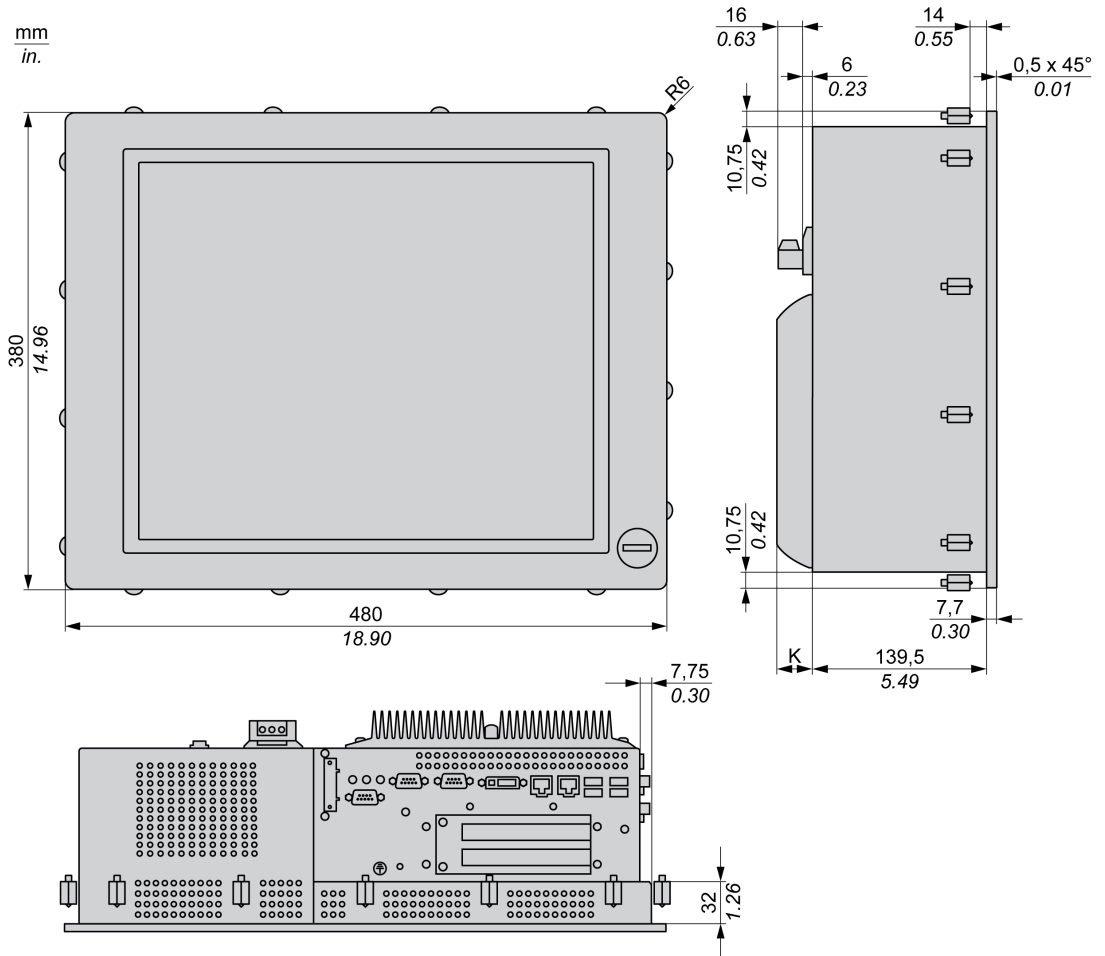

**NOTE:** Measurement “K” depends on which heat sink is used (see page 76).

**Values**

The following table provides the “K” measurement value depending on which heat sink is used:

Industrial Personal Computer Range	“K” Value
Core 2 Duo P8400 Pre-installed Model (0, 1 or 2 slots)	28 mm (1.103 in.)
Atom N270 Pre-installed Model (0, 1 or 2 slots)	12.8 mm (0.503 in.)

The following table shows the general tolerance for the Industrial Personal Computer dimensions:

Nominal Measurement	General Tolerance acc. DIN ISO 2768 Medium
up to 6 mm (up to 0.236 in.)	± 0.1 mm (± 0.004 in.)
6...30 mm (0.236...1.181 in.)	± 0.2 mm (± 0.0078 in.)

<b>Nominal Measurement</b>	<b>General Tolerance acc. DIN ISO 2768 Medium</b>
30...120 mm (1.18...4.724 in.)	± 0.3 mm (± 0.012 in.)
120...400 mm (4.724...15.747 in.)	± 0.5 mm (± 0.02 in.)
400...1000 mm (15.747...39.37 in.)	± 0.8 mm (± 0.031 in.)

## Installation Requirements

### Important Mounting Information

Overheating can cause incorrect software behavior, therefore:

- Ensure that environmental characteristics (see page 61) are respected.
- The Industrial Personal Computer is only permitted for operation in closed rooms.
- The Industrial Personal Computer vent holes must not be covered.
- When mounting the Industrial Personal Computer, adhere to the allowable mounting angle.

### **WARNING**

#### **UNINTENDED EQUIPMENT OPERATION**

- Do not place the Industrial Personal Computer next to other devices that might cause overheating.
- Keep the Industrial Personal Computer away from arc-generating devices such as magnetic switches and non-fused breakers.
- Avoid using the Industrial Personal Computer in environments where corrosive gases are present.
- Install the Industrial Personal Computer in a location providing a minimum clearance of 10 mm (0.39 in.) or more on the left and right sides, 50 mm (1.96 in.) or more on the rear side, and 100 mm (3.93 in.) or more above and below the product from all adjacent structures and equipment.
- Install the Industrial Personal Computer with sufficient clearance to provide for cable routing and cable connectors.

**Failure to follow these instructions can result in death, serious injury, or equipment damage.**

### **CAUTION**

#### **UNINTENDED EQUIPMENT DAMAGES**

- Do not expose the Industrial Personal Computer in direct sunlight.

**Failure to follow these instructions can result in injury or equipment damage.**

### Spacing Requirements

In order to provide sufficient air circulation, mount the Industrial Personal Computer so that the spacing is as follows:

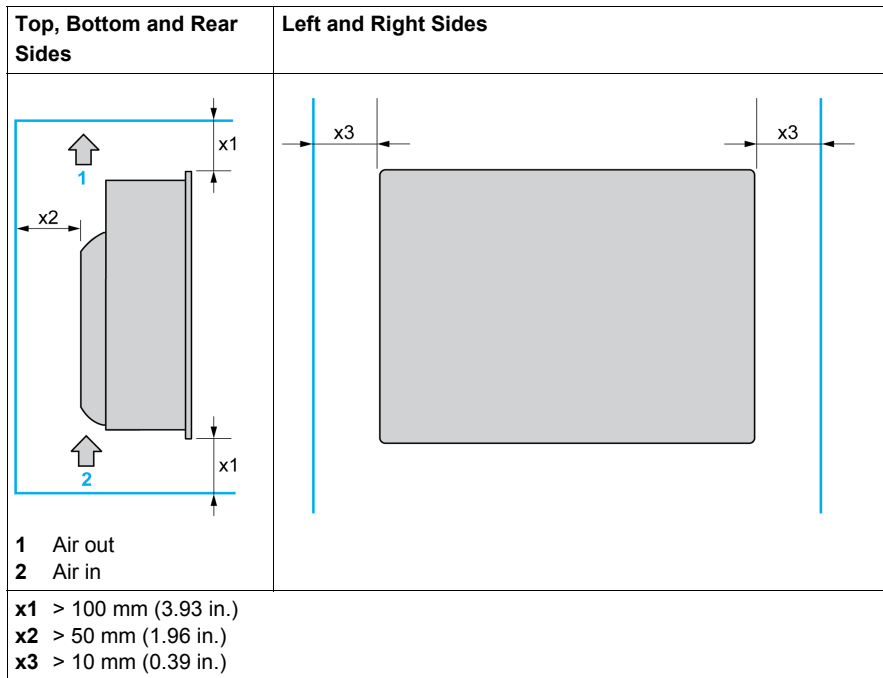

### Mounting Orientation

The following figures shows the allowable mounting orientation for the Industrial Personal Computer depending on the Slide in Slot 1 option:

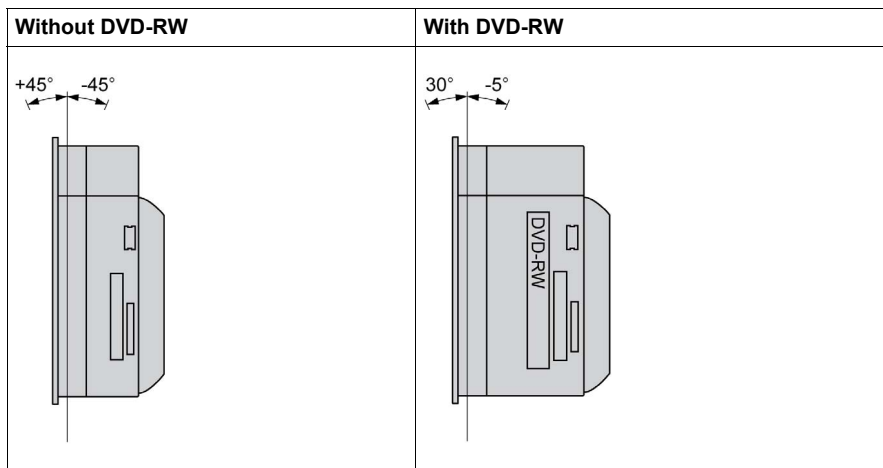

### Panel Cut Dimensions

For cabinet installation, you need to cut the correct sized opening in the installation panel.

The dimensions of the opening for installing the Industrial Personal Computer are shown below:

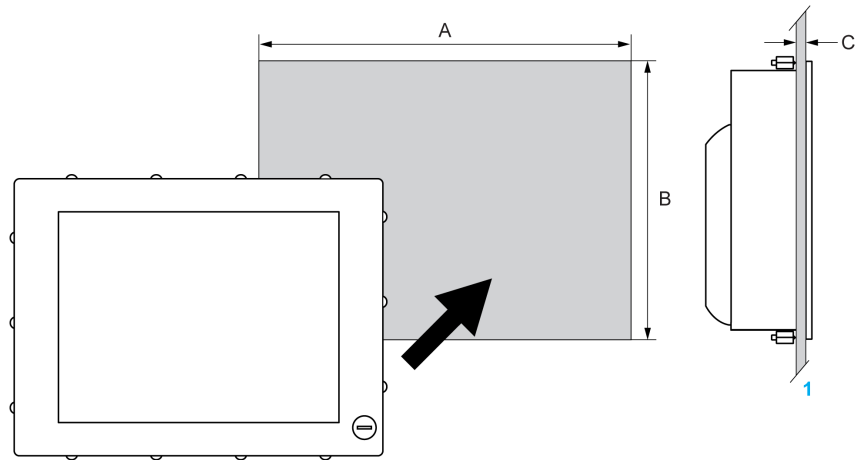

1 Installation panel

Industrial Personal Computer Cut-out	A	B	C
15"	383.5 + 1/- 0 mm (15.10 + 0.04/- 0 in.)	282.5 + 1/- 0 mm (11.12 + 0.04/- 0 in.)	1.6...10 mm (0.06...0.39 in.)
19"	459.5 + 1/- 0 mm (18.09 + 0.04/- 0 in.)	359.5 + 1/- 0 mm (14.15 + 0.04/- 0 in.)	



**NOTE:**

- Ensure the thickness of the installation panel is from 1.6 to 10 mm (0.06 to 0.39 in.).
- All installation panel surfaces used should be strengthened. Due consideration should be given to the weight of the Industrial Personal Computer, especially if high levels of vibration are expected and the installation panel can move. Attach metal reinforcing strips to the inside of the panel near the panel cut-out, to increase the strength of the installation panel.
- Ensure all installation tolerances are maintained.
- The Industrial Personal Computer is designed for use on a flat surface of a Type 4X enclosure (Indoor use only).

## Industrial Personal Computer Installation

### Vibration and Shocks

Extra care should be taken with respect to vibration levels when installing or moving the Industrial Personal Computer. If the Industrial Personal Computer is moved, for example, while it is installed in a rack equipped with caster wheels, it can receive excessive shock and vibration.

### CAUTION

#### EXCESSIVE VIBRATION

- Plan your installation activities so that shock and vibration tolerances in the unit are not exceeded.
- Ensure that the installation panel opening and thickness are within the specified tolerances.
- Before mounting the Industrial Personal Computer into a cabinet or panel, ensure that the installation gasket is in place. The installation gasket provides additional protection from vibration.
- Tighten the installation fasteners using a torque of 0.5 N•m (4.5 lb-in).

**Failure to follow these instructions can result in injury or equipment damage.**

### Installation Gasket

Use of the installation gasket may help extend the operating life of your Industrial Personal Computer. The gasket is required to meet the protection ratings (IP65, IP20) of the Industrial Personal Computer and provides additional protection from vibration. Even if moisture protection is not required, install the gasket delivered with your product.

#### NOTE:

- The installation gasket is replaceable only for Stainless Steel Bezel Model (see page 161).

### CAUTION

#### LOSS OF SEAL

- Inspect the gasket prior to installation or reinstallation, and periodically as required by your operating environment.
- Replace the gasket or the complete Industrial Personal Computer if visible scratches, tears, dirt, or excessive wear are noted during inspection.
- Do not stretch the gasket unnecessarily or allow the gasket to contact the corners or edges of the frame.
- Ensure that the gasket is fully seated in the installation groove.
- Install the Industrial Personal Computer into a panel that is flat and free of scratches or dents.
- Tighten the installation fasteners using a torque of 0.5 N•m (4.5 lb-in).

**Failure to follow these instructions can result in injury or equipment damage.**

### Installing the Industrial Personal Computer Unit

The installation gasket and installation fasteners are required when installing the Industrial Personal Computer.

Follow the steps shown below when installing the Industrial Personal Computer:

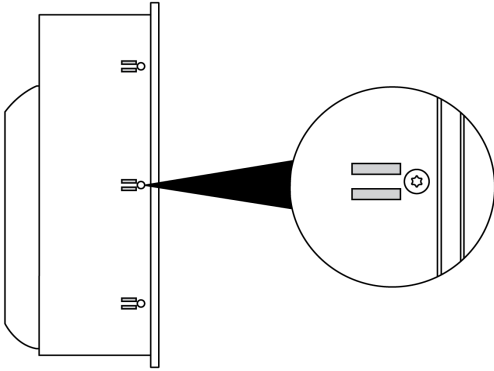
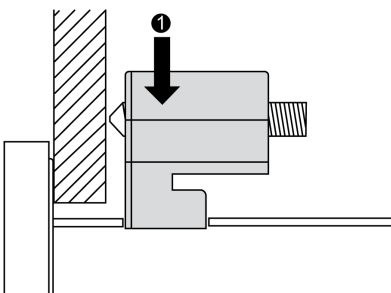
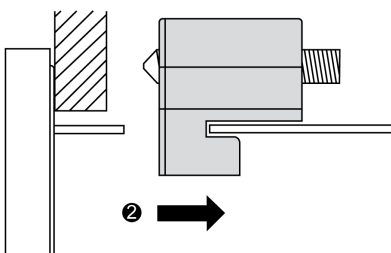
Step	Action
1	Check that the gasket is correctly attached to the Industrial Personal Computer. <b>NOTE:</b> When checking the gasket, avoid contact with the sharp edges of the Industrial Personal Computer frame, and insert it completely into its groove.
2	Install the Industrial Personal Computer in the panel opening (see page 79).
3	Insert each installation fastener securely into the slots at the top, bottom, left and right side of the Industrial Personal Computer:   <p>The number of slots is screen size dependent:</p> <ul style="list-style-type: none"> <li>● 14 slots for the 15" Industrial Personal Computer.</li> <li>● 18 slots for the 19" Industrial Personal Computer.</li> </ul>
4	Insert each fastener in its corresponding slot as shown in the figure below:  
5	Pull the fastener back until it is flush with the rear of the attachment hole:  

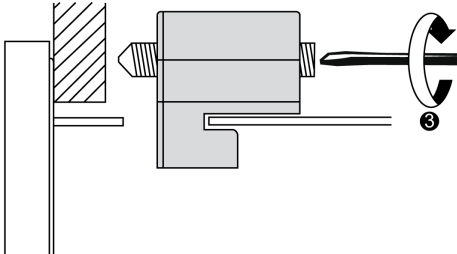
Step	Action
6	<p>Use a 2,5 hexagon head screwdriver to tighten each of the fastener screws and secure the Industrial Personal Computer in place:</p>  <p><b>NOTE:</b> To ensure a high degree of moisture resistance, use a torque of 0.5 N•m (4.5 lb-in).</p>
7	<p>Ensure that the angle is tilted no more than mounting orientation requirements allow (see page 79).</p>

## ⚠ CAUTION

### OVERTORQUE AND LOOSE HARDWARE

- Do not exert more than 0.5 N•m (4.5 lb-in) of torque when tightening the installation fastener, enclosure, accessory, or terminal block screws. Tightening the screws with excessive force can damage the plastic casing of the Industrial Personal Computer.
- When installing or removing screws, ensure that they do not fall inside the Industrial Personal Computer chassis.

**Failure to follow these instructions can result in injury or equipment damage.**

# Implementation

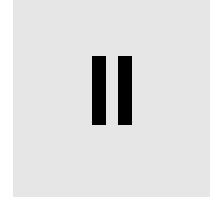

---

## Subject of this Part

This part describes setting up the product.

## What's in this Part?

This part contains the following chapters:

Chapter	Chapter Name	Page
5	Getting Started	87
6	Industrial Personal Computer Connections	89
7	Configuration of the BIOS	107
8	Hardware Modifications	121



## Getting Started

# 5

### First Power-up

#### License Agreement

**NOTE:** Limitations on your usage of the Windows® Operating System are noted in Microsoft's End User License Agreement (EULA). Please read this document before first powering-up.

On first power-up of your Industrial Personal Computer, refer to "PS4000 Series Installation Guide".

#### EFW Manager (Enhanced Write Filter Manager)

The Panel IPC operating system, Windows® Embedded Standard 2009, is installed on a memory card. This card is a re-writable "Compact Flash" card that allows approximately 100,000 write operations.

The EFW Manager (Enhanced Write Filter Manager) minimizes the number of write operations to help extend the life of the CF Card. It loads temporary data (for example, system updates and software operations) into RAM, and does not write this information to the CF Card.

As a result, when using the EFW Manager, restarting the Industrial Personal Computer causes any changes the user made to the system to be overwritten. The following types of modifications may be overwritten if the EFW Manager is active and the system is restarted:

- Newly installed applications.
- Newly installed peripherals.
- Newly created or modified user accounts.
- Network configuration changes (e.g. IP address, default gateway, and so on.)
- Operating System customizations (e.g.background pictures, and so on.)

### **NOTICE**

#### **DATA AND CONFIGURATION LOSS**

- Disable the EFW Manager before making any permanent changes to the hardware, software, or Operating System of the Industrial Personal Computer. Confirm that the EFW icon in the Windows system tray has a red "X".
- Re-enable the EFW Manager after making permanent changes and confirm that the EFW icon in the Windows system tray does not have a red "X". This can help extend the operating life of the CF Card.
- Back up all CF Card data regularly to another storage media.

**Failure to follow these instructions can result in equipment damage.**

### **Enabling/Disabling the EWF Manager**

The status of the EWF Manager may be changed by running the `ChangeEWFstate.exe` program located in the `C:\Utility\Change EWF State` directory. After running this program, you need to restart the system for the change to take effect. You need administrator privileges to enable and disable the EWF Manager.

### **Right Click from Touch Screen Interface**

To access right click function from the touch screen, keep touching the screen for 2 seconds and the corresponding right click function will be activated (for instance, menu will be displayed).

### **Calibrating a Touch Screen**

If the touch position recognized in the panel deviates from the actual touch, you need to calibrate the touch screen. Select the [Start] -> [All Programs] -> [Touch] -> [Touch Screen Calibration]. When a cross appears on the screen, press it, then click [OK] to finish the calibration.



# Industrial Personal Computer Connections

# 6

---

## Subject of this Chapter

This chapter describes the connection of the Industrial Personal Computer to the main power supply. It also describes the USB ports and identifies the serial interface pin assignment.

## What's in this Chapter?

This chapter contains the following topics:

Topic	Page
Grounding	90
Connecting the DC Power Cord	94
Connecting the AC Power Cord	97
Industrial Personal Computer Interface Connections	99

## Grounding

### Overview

The grounding resistance between the Industrial Personal Computer ground and the ground must be 100 Ω or less. When using a long grounding wire, check the resistance and, if required, replace a thin wire with a thicker wire and place it in a duct. In addition, refer to the table below for maximum lengths of various wire thicknesses.

### Ground Wire Dimensions

Wire Cross-section	Maximum Line Length
2.5 mm <sup>2</sup> (AWG 13)	30 m (98 ft)
	60 m (196 ft) round trip.

### Precaution

**⚠ WARNING**

**UNINTENDED EQUIPMENT OPERATION**

- Use only the authorized grounding configurations shown below.
- Confirm that the grounding resistance is 100 Ω or less.
- Test the quality of your ground connection before applying power to the device.  
Excess noise on the ground line can disrupt operations of the Industrial Personal Computer.

**Failure to follow these instructions can result in death, serious injury, or equipment damage.**

### Dedicated Ground

Connect the Industrial Personal Computer ground to a dedicated ground:

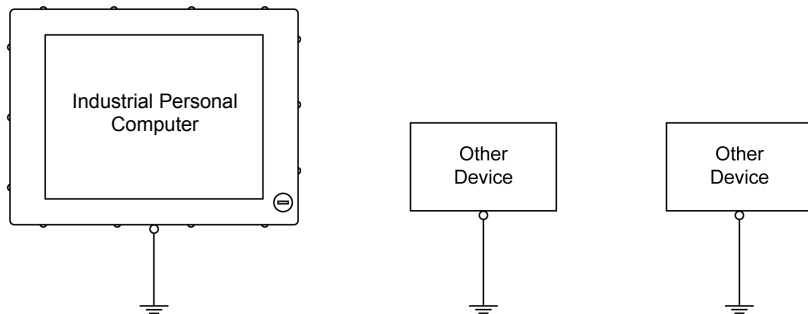

### Shared Ground Allowed

If a dedicated ground is not possible, use a shared ground, as shown below:

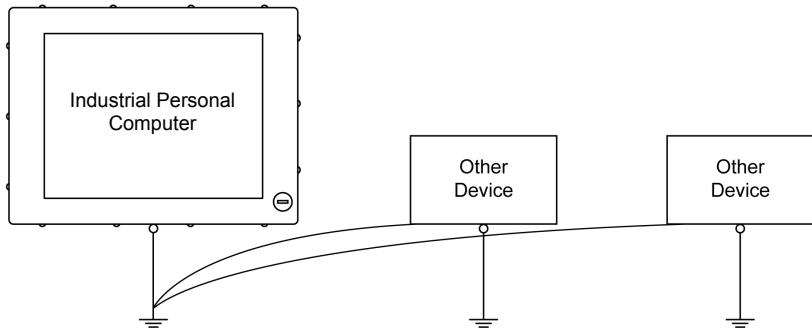

### Shared Ground not Allowed

Do not connect the Industrial Personal Computer to ground through other devices using shared ground terminals:

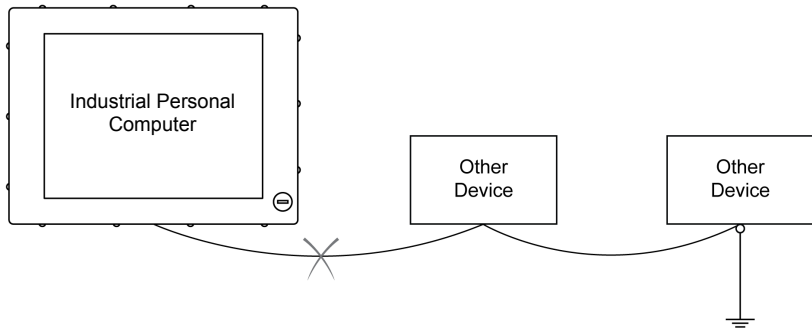

### Shared Ground - Avoid Ground Loop

When connecting an external device to a Industrial Personal Computer with the shield ground (SG), ensure that a ground loop is not created. The Industrial Personal Computer's ground connection screw and SG are connected internally.

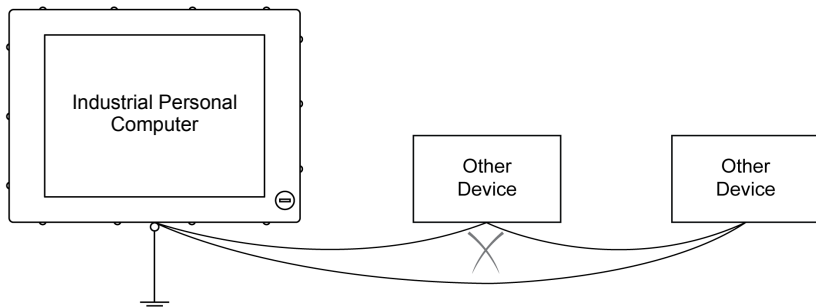

### Grounding Procedure

The Industrial Personal Computer functional ground has 2 connections:

- Supply voltage
- Ground connection screw

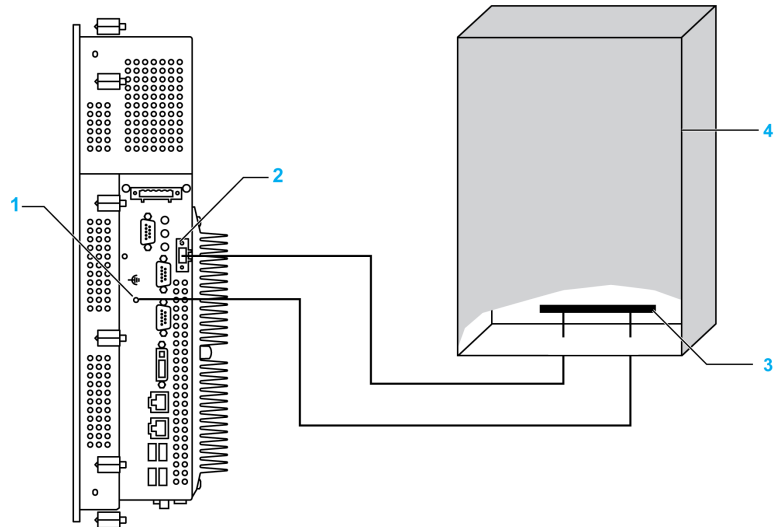

- 1 Ground connection screw (protective earth screw for AC Industrial Personal Computer)
- 2 Supply voltage
- 3 Grounding strip
- 4 Switching cabinet

When grounding, follow the procedure below:

Step	Action
1	Check that the grounding resistance is 100 $\Omega$ or less.
2	When connecting the SG line to another device, ensure that the design of the system/connection does not produce a ground loop. <b>NOTE:</b> The SG ground connection screw are connected internally in the Industrial Personal Computer.
3	Use 2.5 mm <sup>2</sup> (AWG 13) wire to make the ground connection. Create the connection point as close to the Industrial Personal Computer as possible and make the wire as short as possible.

## Grounding I/O Signal Lines

### DANGER

#### EXPLOSION HAZARD

- Always confirm the ANSI/ISA 12.12.01 and CSA C22.2 N°213 hazardous location rating of your device before installing or using it in a hazardous location.
- To power on or power off a Industrial Personal Computer installed in a Class I, Division 2 hazardous location, you must either:
  - Use a switch located outside the hazardous environment, or
  - Use a switch certified for Class I, Division 1 operation inside the hazardous area.
- Do not disconnect equipment unless power has been switched off or the area is known to be non-hazardous. This applies to all connections including power, ground, serial, parallel, and network connections.
- Never use unshielded / ungrounded cables in hazardous locations.
- Use only non-incendive USB configuration.
- When enclosed, keep enclosure doors and openings closed at all times to avoid the accumulation of foreign matter inside the workstation.

**Failure to follow these instructions will result in death or serious injury.**

Electromagnetic radiation may interfere with the control communications of the Industrial Personal Computer.

### WARNING

#### UNINTENDED EQUIPMENT OPERATION

- If wiring of I/O lines near power lines or radio equipment is unavoidable, use shielded cables and ground one end of the shield to the Industrial Personal Computer ground connection screw.
- Do not wire I/O lines in proximity to power cables, radio devices, or other equipment that may cause electromagnetic interference.

**Failure to follow these instructions can result in death, serious injury, or equipment damage.**

## Connecting the DC Power Cord

### Precaution

When connecting the power cord to the power connector on the Industrial Personal Computer, first ensure that the power cord is disconnected from the DC power supply.

### **DANGER**

#### **HAZARD OF ELECTRIC SHOCK, EXPLOSION OR ARC FLASH**

- Remove all power from the device before removing any covers or elements of the system, and prior to installing or removing any accessories, hardware, or cables.
- Unplug the power cable from both the Industrial Personal Computer and the power supply.
- Always use a properly rated voltage sensing device to confirm power is off.
- Replace and secure all covers or elements of the system before applying power to the unit.
- Use only the specified voltage when operating the Industrial Personal Computer. The AC unit is designed to use 100...240 Vac input. The DC unit is designed to use 24 Vdc. Always check whether your device is AC or DC powered before applying power.

**Failure to follow these instructions will result in death or serious injury.**

### **WARNING**

#### **UNINTENDED EQUIPMENT OPERATION**

- Ensure that power, communication, and accessory connections do not place excessive stress on the ports. Consider the vibration environment when making this determination.
- Securely attach power, communication, and external accessory cables to the panel or cabinet.
- Use only commercially available USB cables.

**Failure to follow these instructions can result in death, serious injury, or equipment damage.**

### Wiring and Connecting the Terminal Block

The table below describes how to connect the power cord to the DC Industrial Personal Computer:

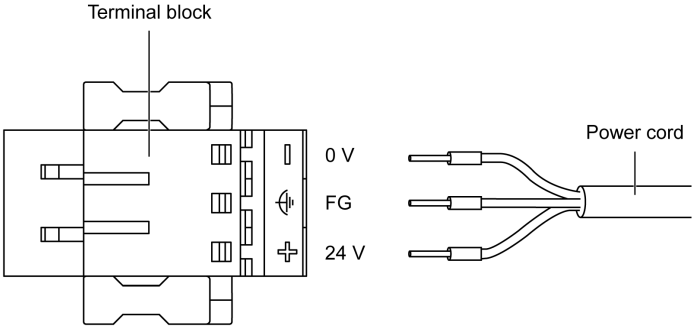
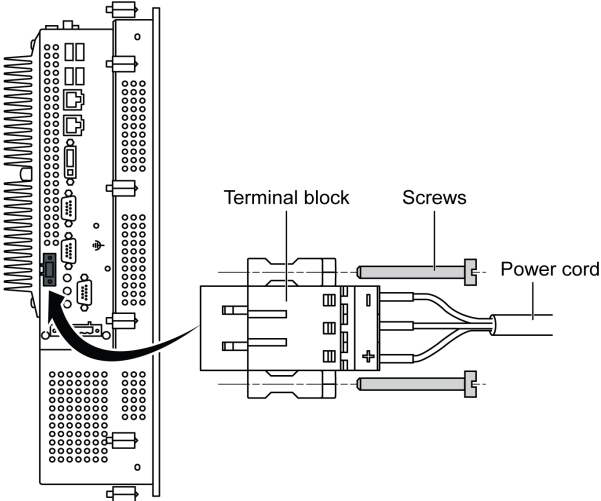
Step	Action
1	Remove all power from the Industrial Personal Computer and confirm that the DC power supply has been disconnected from its power source.
2	<p>Remove the terminal block from the power connector and connect the power cord to the terminal block as shown below:</p>  <p>Use wire with:</p> <ul style="list-style-type: none"> <li>● cross-section 0.75 mm<sup>2</sup> to 2.0 mm<sup>2</sup> (AWG 18 to AWG 14)</li> <li>● maximum operating temperature not less than 75 °C (167 °F).</li> </ul>
3	<p>Place the terminal block in the power connector and tighten the screws.</p>  <p><b>NOTE:</b> The recommended torque to tighten these screws is 0.5 N•m (4.5 lb-in).</p>

### Marine Certification Connections

If the product is used in an environment requiring marine certification, a power line filter must be in the power line.

For the Noise Filter for Marine Certification, please refer to "Accessories" (page. 161).

### Possible Connections

#### Connection to a Ground-Referenced DC Power System:

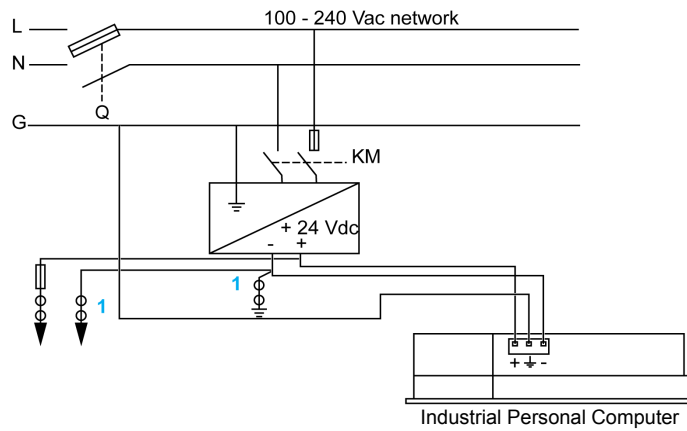

**Q** : Main Power Contact

**KM** : Line contacts

**1** : Residual Current Detector for detecting grounding faults



## Connecting the AC Power Cord

### Precaution

When connecting the power cord to the power connector on the Industrial Personal Computer, first ensure that the power cord is disconnected from the AC power supply.

### **DANGER**

#### **HAZARD OF ELECTRIC SHOCK, EXPLOSION OR ARC FLASH**

- Remove all power from the device before removing any covers or elements of the system, and prior to installing or removing any accessories, hardware, or cables.
- Unplug the power cable from both the Industrial Personal Computer and the power supply.
- Always use a properly rated voltage sensing device to confirm power is off.
- Replace and secure all covers or elements of the system before applying power to the unit.
- Use only the specified voltage when operating the Industrial Personal Computer. The AC unit is designed to use 100...240 Vac input. The DC unit is designed to use 24 Vdc. Always check whether your device is AC or DC powered before applying power.

**Failure to follow these instructions will result in death or serious injury.**

### **WARNING**

#### **EQUIPMENT DISCONNECTION OR UNINTENDED EQUIPMENT OPERATION**

- Ensure that power, communication, and accessory connections do not place excessive stress on the ports. Consider the vibration environment when making this determination.
- Securely attach power, communication, and external accessory cables to the panel or cabinet.
- Use only commercially available USB cables.

**Failure to follow these instructions can result in death, serious injury, or equipment damage.**

### Wiring and Connecting the Terminal Block

The table below describes how to connect the power cord to the AC Industrial Personal Computer:

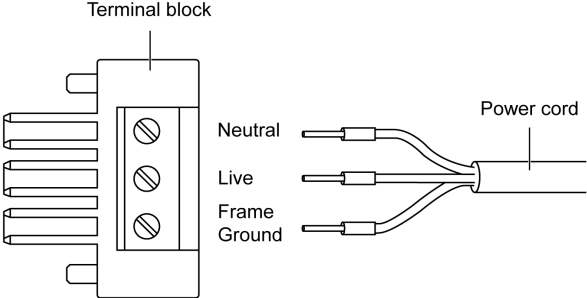
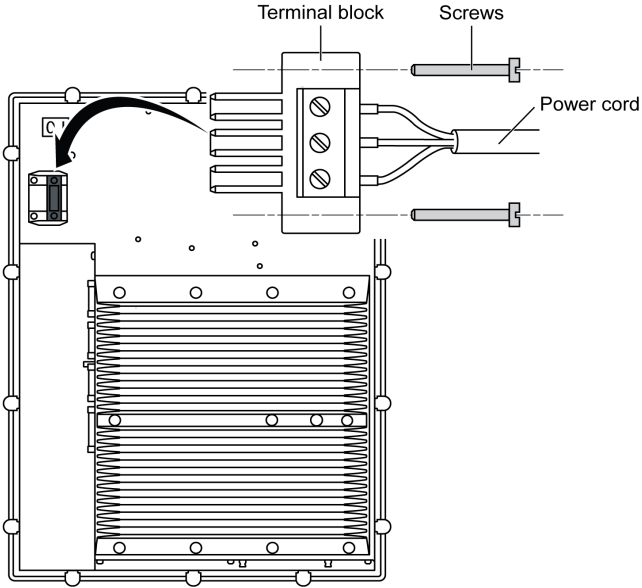
Step	Action
1	Confirm that the power cord is unplugged from the power supply.
2	<p>Remove the AC terminal block from the power connector and connect the power cord to the AC terminal block as shown below:</p>  <p>Use wire with:</p> <ul style="list-style-type: none"> <li>● cross-section 0.75 mm<sup>2</sup> to 2.5 mm<sup>2</sup> (AWG 18 to AWG 12)</li> <li>● maximum operating temperature not less than 75 °C (167 °F).</li> </ul> <p>Attach the wire ends with screws. Use a slot screwdriver (size 0.6 x 3.5) to tighten the connector screws. Required torque is: 0.5...0.6 N·m (4.5...5.3 lb-in).</p>
3	<p>Place the terminal block in the power connector at the rear side of the Industrial Personal Computer and tighten the screws:</p>  <p><b>NOTE:</b> The recommended torque to tighten these screws is 0.5 N·m (4.5 lb-in).</p>

## Industrial Personal Computer Interface Connections

### Introduction

The information below describes usage of the interface connections of the Industrial Personal Computer in Class I, Division 2 Groups A, B, C, and D hazardous locations.

### DANGER

#### EXPLOSION HAZARD

- Always confirm the ANSI/ISA 12.12.01 and CSA C22.2 N°213 hazardous location rating of your device before installing or using it in a hazardous location.
- To power on or power off a Industrial Personal Computer installed in a Class I, Division 2 hazardous location, you must either:
  - Use a switch located outside the hazardous environment, or
  - Use a switch certified for Class I, Division 1 operation inside the hazardous area.
- Do not disconnect equipment unless power has been switched off or the area is known to be non-hazardous. This applies to all connections including power, ground, serial, parallel, and network connections.
- Never use unshielded / ungrounded cables in hazardous locations.
- Use only non-incendive USB configuration.
- When enclosed, keep enclosure doors and openings closed at all times to avoid the accumulation of foreign matter inside the workstation.

**Failure to follow these instructions will result in death or serious injury.**

### WARNING

#### EQUIPMENT DISCONNECTION OR UNINTENDED EQUIPMENT OPERATION

- Ensure that power, communication, and accessory connections do not place excessive stress on the ports. Consider the vibration environment when making this determination.
- Securely attach power, communication, and external accessory cables to the panel or cabinet.
- Use only commercially available USB cables.

**Failure to follow these instructions can result in death, serious injury, or equipment damage.**

### USB Connections

Non-incendive equipment (keyboards, mouse) are permitted for use on the Industrial Personal Computer (Associated Apparatus) USB ports 1, 2, 3, 4 and 5. In addition to being non-incendive, any equipment connected to the USB ports 1, 2, 3, 4 and 5 must satisfy the following criteria.

The following figure shows the USB cable wiring:

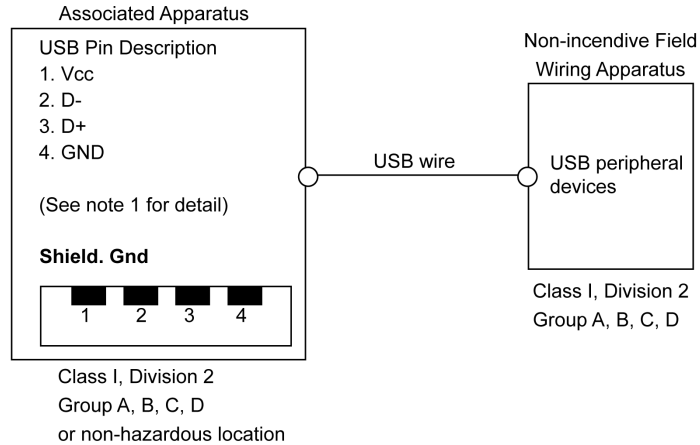

**Notes:**

1. The following table gives the Non-incendive Circuit Parameters:

Circuit Parameters	USB ports 1 and 3	USB ports 2 and 4	USB port 5
Open-circuit voltage = $V_{oc}$	5.066 V	5.26 V	5.089 V
Short-circuit current = $I_{sc}$	1320 mA	830 mA	1322 mA
Associated capacitance = $C_a$	20 $\mu$ F	20 $\mu$ F	20 $\mu$ F
Associated inductance = $L_a$	16.8 $\mu$ H	16.8 $\mu$ H	16.8 $\mu$ H

The Entity Concept allows interconnection of non-incendive apparatus with associated apparatus – not specifically examined combinations – as a system when the approved values of  $V_{oc}$  (or  $U_o$ ) and  $I_{sc}$  (or  $I_o$ ) for the associated apparatus are less than or equal to  $V_{max}$  ( $U_i$ ) and  $I_{max}$  ( $I_i$ ) for the non-incendive apparatus, and the approved values of  $C_a$  ( $C_o$ ) and  $L_a$  ( $L_o$ ) for the associated apparatus are greater than or equal to  $C_i + C_{cable}$  and  $L_i + L_{cable}$ , respectively, for the non-incendive field wiring apparatus.

2. Associated Non-incendive Field Wiring Apparatus shall satisfy the following:

Industrial Personal Computer	-	Associated Non-incendive Field Wiring Apparatus (Mouse, Keyboard)
$V_{oc}$	$\leq$	$V_{max}$
$I_{sc}$	$\leq$	$I_{max}$
$C_a$	$\geq$	$C_i + C_{cable}$
$L_a$	$\geq$	$L_i + L_{cable}$

3. If the electrical parameters of the cable are unknown, the following values may be used:

- $C_{cable} = 196.85 \text{ pF/m}$  (60 pF/ft)
- $L_{cable} = 0.656 \text{ }\mu\text{H/m}$  (0.20  $\mu$ H/ft)

4. Wiring methods must be in accordance with the electrical code of the country in use.

The Industrial Personal Computer must be installed in an enclosure. If installed in a Class I, Division 2 Location, the enclosure must be capable of accepting one or more Division 2 wiring methods.

**⚠ DANGER****EXPLOSION HAZARD**

- Substitution of components may impair suitability for Class I, Division 2.
- Do not energize or disconnect the device while area is known to be hazardous.
- The associated non-incendive field wiring apparatus shall not be connected in parallel unless permitted by the associated non-incendive apparatus approval.

**Failure to follow these instructions will result in death or serious injury.**

The Industrial Personal Computer is suitable for use in Class I, Division 2, Groups A, B, C, D and provides non-incendive field wiring to apparatus in Class I, Division 2, Groups A, B, C, D.

**Serial Interface Connections**

This interface is used to connect Industrial Personal Computer to remote equipment, via an RS232C cable. The connector is a D-Sub 9-pin plug connector.

By using a long PLC cable to connect to the Industrial Personal Computer, it is possible that the cable can be at a different electrical potential than the panel, even if both are connected to ground.

The Industrial Personal Computer serial port is not isolated. The SG (signal ground) and the functional ground (FG) terminals are connected inside the Panel IPC.

**⚠ ⚠ DANGER****ELECTRIC SHOCK**

- Make a direct connection between the ground connection screw and ground.
- Do not connect other devices to ground through the ground connection screw of this device.
- Install all cables according to local codes and requirements. If local codes do not require grounding, follow a reliable guide such as the US National Electrical Code, Article 800.

**Failure to follow these instructions will result in death or serious injury.**

The following table shows the D-Sub9 pin assignments:

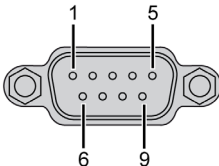
Pin	Assignment	
1	DCD	D-Sub9 pin plug connector: 
2	RXD	
3	TXD	
4	DTR	
5	GND	
6	DSR	
7	RTS	
8	CTS	
9	RI	

Any excessive weight or stress on communication cables may disconnect the equipment.

** CAUTION**

**LOSS OF POWER**

- Ensure that communication connections do not place excessive stress on the communication ports of the Industrial Personal Computer.
- Securely attach communication cables to the panel or cabinet.
- Use only D-Sub 9 pin cables with a locking system in good condition.

**Failure to follow these instructions can result in injury or equipment damage.**

## COM Expansion Board (Built-in option)

The COM Expansion Board is an option which can be pre-installed when shipped. The serial interface is a combined RS-232C/RS-422/RS-485 interface with D-SUB 9 pin connector.

The operating mode (RS-232C/RS-422/RS-485) is selected automatically, depending on the electrical connection. The serial interface and COM Expansion Board use a different pin assignment for RS-232C communication.

When using the COM Expansion Board for RS-232C communication, pins 1, 4, 6 and 9 are not connected to anything.

### **⚠ CAUTION**

#### **UNINTENDED PIN WIRING**

Do not connect anything to n.c. pins.

**Failure to follow the instruction can result in unintended communication.**

#### **COM Expansion Board Pin Assignments**

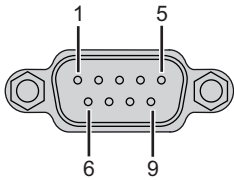
Connector	D-Sub 9 pin plug		
Type	RS-232C not modem compatible; Electrically isolated		
UART	16550 compatible, 16 byte FIFO		
Transfer rate	Max. 115 kBit/s		
Cable length	Max. 15 meters (49.21 feet)	Max. 1200 meters (3937.01 feet)	
<b>Pin</b>	<b>Assignments (RS-232C)</b>	<b>Assignments (RS-422)</b>	
1	n.c.	TXD\	
2	RXD	n.c.	
3	TXD	n.c.	
4	n.c.	TXD	
5	GND	GND	
6	n.c.	RXD\	
7	RTS	n.c.	
8	CTS	n.c.	
9	n.c.	RXD	

### RS-232C - Bus length and cable type

The maximum transfer rate of 115 kBit/s depends on the cable type being used.

Distance [m]	Transfer rate [kBit/s]
≤ 15	Typ. 64
≤ 10	Typ. 115
≤ 5	Typ. 115

The material used for the cable should preferably have all or most of the following properties in order to reach an optimal transfer rate.

RS-232C cable	Property
Signal lines	
Cable cross section	4 x 0.16 mm <sup>2</sup> (26AWG), tinned Cu wire
Wire insulation	PE
Conductor resistance	≤ 82 Ω/km
Stranding	Wires stranded in pairs
Shield	Paired shield with aluminum foil
Grounding line	
Cable cross section	1 x 0.34 mm <sup>2</sup> (22AWG/19), tinned Cu wire
Wire insulation	PE
Conductor resistance	≤ 59 Ω/km
Outer sheathing	
Material	PUR mixture
Characteristics	Halogen free
Entire shielding	From tinned cu wires



## RS-422 - Bus length and cable type

The RTS line must be switched on to activate the sender.

The maximum transfer rate of 115 kBit/s depends on the cable type being used.

Distance [m]	Transfer rate [kBit/s]
1200	Typ. 115

The material used for the cable should preferably have all or most of the following properties in order to reach an optimal transfer rate.

RS-422 cable	Property
Signal lines Cable cross section Wire insulation Conductor resistance Stranding Shield	4 x 0.25 mm <sup>2</sup> (24AWG/19), tinned Cu wire PE ≤ 82 Ω/km Wires stranded in pairs Paired shield with aluminum foil
Grounding line Cable cross section Wire insulation Conductor resistance	1 x 0.34 mm <sup>2</sup> (22AWG/19), tinned Cu wire PE ≤ 59 Ω/km
Outer sheathing Material Characteristics Entire shielding	PUR mixture Halogen free From tinned cu wires

## RS-485 interface operation

The pins of the RS-422 default interface (1, 4, 6 and 9) should be used for operation. The pins should be connected as shown.

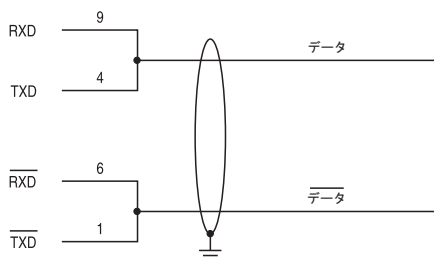

The RTS line must be switched each time the driver is sent and received; there is no automatic switch back. This cannot be configured in Windows.

The voltage drop caused by long line lengths can lead to greater potential differences between the bus stations, which can hinder communication. This can be improved by running ground wire with the others.

The line ends of the RS-485 interface should (at least for longer line lengths or larger transfer rates) be closed. Normally a passive terminator can be used on the bus ends by connecting each of the signal lines with 120 Ω resistance.

### RS-485 - Bus length and cable type

The maximum transfer rate of 115 kBit/s depends on the cable type being used.

Distance [m]	Transfer rate [kBit/s]
1200	Typ. 115

The material used for the cable should preferably have all or most of the following properties in order to reach an optimal transfer rate.

RS-485 cable	Property
Signal lines Cable cross section Wire insulation Conductor resistance Stranding Shield	4 x 0.25 mm <sup>2</sup> (24AWG/19), tinned Cu wire PE ≤ 82 Ω/km Wires stranded in pairs Paired shield with aluminum foil
Grounding line Cable cross section Wire insulation Conductor resistance	1 x 0.34 mm <sup>2</sup> (22AWG/19), tinned Cu wire PE ≤ 59 Ω/km
Outer sheathing Material Characteristics Entire shielding	PUR mixture Halogen free From tinned cu wires

# Configuration of the BIOS

# 7

---

## What's in this Chapter?

This chapter contains the following topics:

Topic	Page
BIOS Options	108
Main Menu	110
Advanced Menu - USB Configuration	112
Boot Menu	115
Security Menu	117
Exit Menu	119

## BIOS Options

### General Information

BIOS stands for “Basic Input Output System”. It is the most basic communication between the user and the hardware. The BIOS used in the Industrial Personal Computer is produced by Pro-face.

The BIOS Setup Utility lets you modify basic system configuration settings. These settings are stored in CMOS and in an EEPROM (as a backup).

The CMOS data is buffered by a battery (if present), and remains in the Industrial Personal Computer even when the power is turned off (24 Vdc power supply is disconnected).

### BIOS Setup and Boot Procedure

BIOS is immediately activated when switching on the power supply of the Industrial Personal Computer or pressing the power button. The system checks if the setup data from the EEPROM is OK. If the data is OK, then it is transferred to CMOS. If the data is not OK, then the CMOS data is checked for validity. A message appears if the CMOS data contains anomalies, but you can continue the boot procedure by pressing the [F1] key. To prevent the message from appearing at each restart, open the BIOS setup by pressing the [DEL] key and re-save the settings.

BIOS reads the system configuration information in CMOS RAM, checks the system, and configures it using the Power On Self Test (POST).

When these preliminaries are complete, the BIOS seeks the operating system from the data storage devices available (hard drive, floppy drive, and so on). BIOS launches the operating system and hands over to the operating system control of system operations.

To enter BIOS Setup, press the [DEL] key after the USB controller has been initialized, and as soon as the following message appears on the monitor (during POST): “Press DEL to run Setup”.

### BIOS Setup Keys

The following keys are enabled during the POST:

Key	Function
DEL	Enters the BIOS setup menu
F12	Using the [F12] key, you can boot from the network.

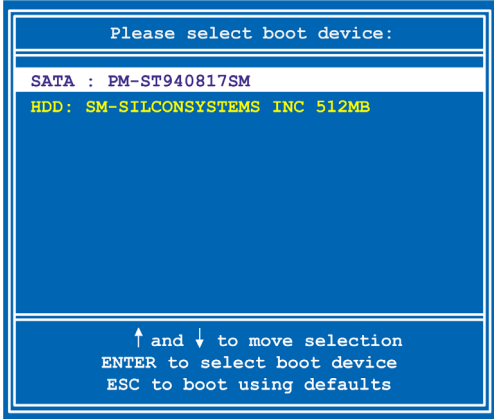
Key	Function
F11	<p>Displays the boot menu. Lists all bootable devices that are connected to the system. Use the up cursor ↑ and down cursor ↓ and then press the [Enter] key to select the boot device.</p> 
Pause	Pressing the [Pause] key stops the POST. Press any other key to resume the POST.

**NOTE:** Keys input from the USB keyboard are only registered after the USB controller has been initialized.

You can use the following keys after entering the BIOS setup:

Key	Function
F1	General help.
Cursor ↑	Moves to the previous item.
Cursor ↓	Goes to the next item.
Cursor ←	Moves to the previous item.
Cursor →	Goes to the next item.
±	Changes the value of the selected item.
Enter	Changes to the selected menu.
PgUp ↑	Changes to the previous page.
PgDn ↓	Changes to the next page.
Start	Jumps to the first BIOS menu item or object.
End	Jumps to the last BIOS menu item or object.
F2/F3	Switches the colors of the BIOS setup.
F7	Resets any changes.
F9	Loads these settings for all BIOS configurations.
F10	Saves and closes BIOS setup.
Esc	Exits the submenu.

## Main Menu

### Main Menu

When you press the [DEL] key during startup, the **Main** BIOS setup menu appears. The following figure shows the **Main** menu for Atom N270 Preinstalled Model:

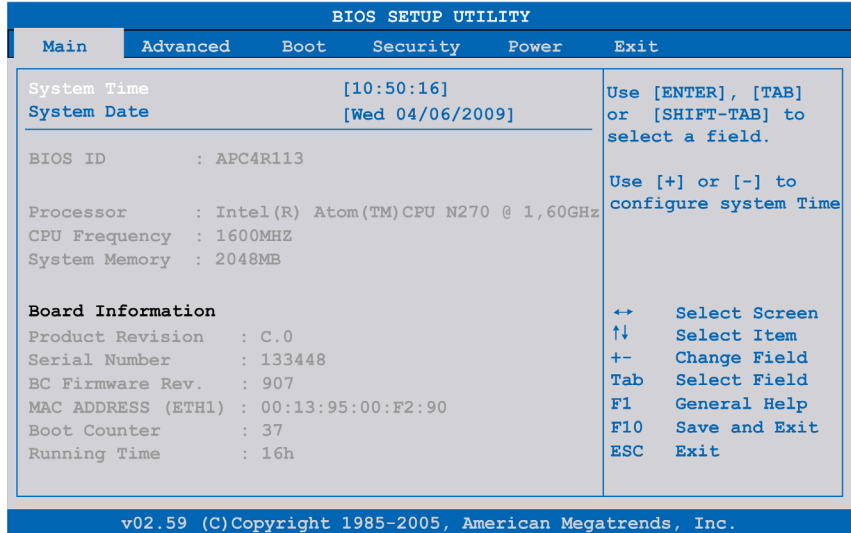

The following figure shows the **Main** menu for Core 2 Duo P8400 Preinstalled Model:

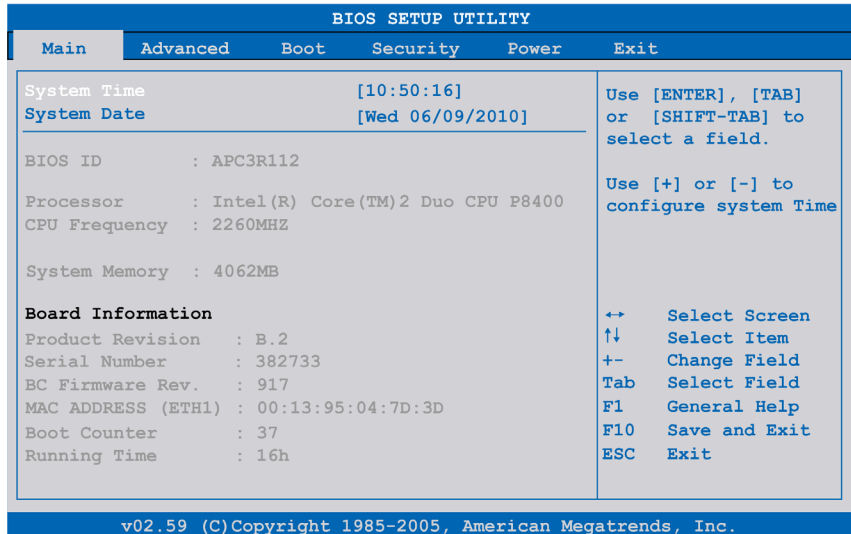

The following table shows the **Main** menu setting options:

<b>BIOS Setting</b>	<b>Description</b>	<b>Setting Options</b>	<b>Effect</b>
<b>System Time</b>	This is the current time setting. The time is maintained by the battery (CMOS battery) when the unit is turned off.	Change the time	Set the time using the format Hours:Minutes:Seconds (hh:mm:ss).
<b>System Date</b>	This is the current date setting. The time is maintained by the battery (CMOS battery) when the unit is turned off.	Change the date	Set the date using the format Month:Day:Year (mm:dd:yyyy).
<b>BIOS ID</b>	Displays the BIOS detected.	None	-
<b>Processor</b>	Displays the processor type	None	-
<b>CPU Frequency</b>	Displays the processor frequency	None	-
<b>System Memory</b>	Displays the system memory size	None	-
<b>Product Revision</b>	Displays the CPU board HW revision.	None	-
<b>Serial Number</b>	Displays the CPU board serial number.	None	-
<b>BC Firmware Rev.</b>	Displays the CPU board controller firmware revision.	None	-
<b>MAC Adresse (ETH1)</b>	Displays the MAC addresses assigned for the ETH1 interface.	None	-
<b>Boot Counter</b>	Displays the boot counter - each restart increments the counter by one (max. 16777215).	None	-
<b>Running Time</b>	Displays the running time in hours. (max. 65535).	None	-

## Advanced Menu - USB Configuration

### Advanced Menu

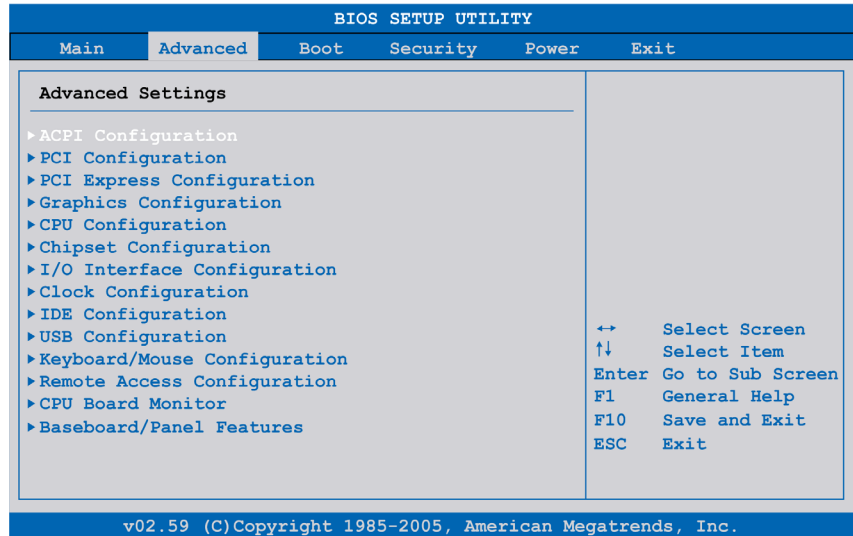

The following tables shows the accessible submenus from **Advanced** menu:

BIOS Setting	Description	Setting Options	Effect
<b>ACPI Configuration</b>	Configures APCI devices.	Enter	Opens submenu
<b>PCI Configuration</b>	Configures PCI devices.	Enter	Opens submenu
<b>PCI Express Configuration</b>	Configures the PCI Express.	Enter	Opens submenu
<b>Graphics Configuration</b>	Configures the graphic settings.	Enter	Opens submenu
<b>CPU Configuration</b>	Configures CPU settings.	Enter	Opens submenu
<b>Chipset Configuration</b>	Configures the chipset functions.	Enter	Open submenu
<b>I/O Interface Configuration</b>	Configures the I/O devices.	Enter	Opens submenu
<b>Clock Configuration</b>	Configures clock settings.	Enter	Opens submenu
<b>IDE Configuration</b>	Configures the IDE functions.	Enter	Opens submenu
<b>USB Configuration</b>	Configures USB settings	Enter	Opens submenu (see page 113)
<b>Keyboard/Mouse Configuration</b>	Configures the keyboard/mouse options	Enter	Opens submenu
<b>Remote Access Configuration</b>	Configures the remote access settings.	Enter	Opens submenu
<b>CPU Board Monitor</b>	Displays the current voltage and temperature of the processor	Enter	Opens submenu
<b>Baseboard/Panel Features</b>	Displays device specific information and setup of device specific values.	Enter	Opens submenu



## USB Configuration Submenu

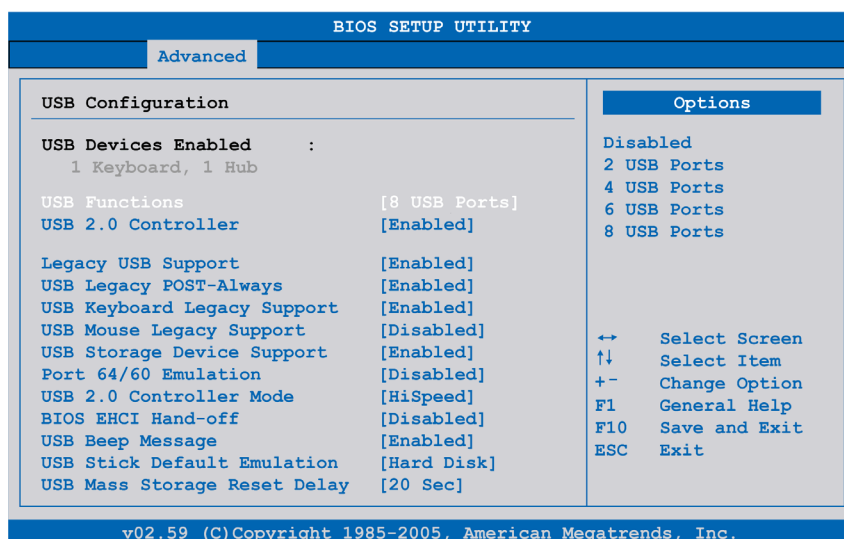

The following table shows the USB Configuration menu setting options:

BIOS Setting	Description	Setting Options	Effect
<b>USB Functions</b>	You can enable or disable USB ports here. USB port numbers (for example, USB1, USB3, and so on) are printed on the Industrial Personal Computer housing.	Disabled	Disables the USB port.
		2 USB Ports	USB1, USB3 are enabled.
		4 USB Ports	USB1, USB2, USB3, USB4, are enabled.
		5 USB Ports	USB1, USB2, USB3, USB4, USB5 are enabled.
<b>USB 2.0 Controller</b>	Option for enabling or disabling USB 2.0.	Enabled	All USB interfaces run in USB 2.0 mode.
		Disabled	All USB interfaces run in USB 1.1 mode.
<b>Legacy USB Support</b>	You can enable/disable Legacy USB support here. USB interfaces do not function during startup. USB is supported after the operating system has started. USB keyboard is recognized during the POST.	Disabled	Disables this function.
		Enabled	Enables this function.
		Auto	Automatic enabling.
<b>USB Legacy POST-Always</b>	Option to enable Legacy USB Support during the POST (Power On Self Test), the same as the Legacy USB Support setting.	Enabled	Enables calling the BIOS Setup during the POST with a USB keyboard.
		Disabled	Disables this function.
<b>USB Keyboard Legacy Support</b>	You can enable/disable USB keyboard support here.	Disabled	Disables this function.
		Enabled	Enables this function.
<b>USB Mouse Legacy Support</b>	You can enable/disable USB mouse support here.	Disabled	Disables this function.
		Enabled	Enables this function.
<b>USB Storage Device Support</b>	You can enable/disable USB storage device support here.	Disabled	Disables this function.
		Enabled	Enables this function.

BIOS Setting	Description	Setting Options	Effect
<b>Port 64/60 Emulation</b>	You can enable/disable Port 64/60 emulation here.	Disabled	USB keyboard functions in all systems excluding Windows NT.
		Enabled	USB keyboard functions in Windows NT.
<b>USB 2.0 Controller Mode</b>	Defines settings for the USB controller.	Full speed	12 Mbps
		Hi speed	480 Mbps
<b>BIOS EHCI Hand-Off</b>	Defines operating system support for the fully automatic EHCI function.	Disabled	Disables this function.
		Enabled	Enables this function.
<b>USB Beep Message</b>	Option for outputting a tone each time a USB device is detected by the BIOS during the POST.	Disabled	Disables this function.
		Enabled	Enables this function.
<b>USB Stick Default Emulation</b>	You can set how to use the USB devices.	Auto	USB devices with less than 530 MB of memory are simulated as floppy disk drives. Devices with larger capacities are simulated as hard drives.
		Hard disk	An HDD-formatted drive (such as Zip drive) can be used as a FDD for starting the system.
<b>USB Mass Storage Reset Delay</b>	You can define the amount of time the USB device POST waits after the device start command. <b>NOTE:</b> The message "No USB mass storage device detected" will appear if no USB memory device is installed.	10 Sec, 20 Sec, 30 Sec, 40 Sec	Manually define the delay time.

## Boot Menu

### Boot Menu

BIOS SETUP UTILITY					
Main	Advanced	Boot	Security	Power	Exit
Boot Priority Selection		[Type Based]	The device based boot priority list allows to select from a list of currently detected devices.		
Boot Device Priority			The type based boot priority list allows to select device types even if a respective device is not (yet) present.		
1st	Boot Device	[Primary Master]			
2st	Boot Device	[Primary Slave]			
3rd	Boot Device	[USB Floppy]			
4th	Boot Device	[USB Removable Devi]			
5th	Boot Device	[USB Harddisk]			
6th	Boot Device	[USB CDROM]			
7th	Boot Device	[Secondary Master]			
8th	Boot Device	[Secondary Slave]			
Boot Settings Configuration			↔ Select Screen		
Quick Boot		[Enabled]	↑↓ Select Item		
Quiet Boot		[Disabled]	+- Change Option		
Automatic Boot List Retry		[Disabled]	F1 General Help		
AddOn ROM Display Mode		[Keep Current]	F10 Save and Exit		
Halt On Error		[Disabled]	ESC Exit		
Hit 'DEL' Message Display		[Enabled]			
Interrupt 19 Capture		[Disabled]			
PXE Boot to LAN (ETH1)		[Disabled]			
Slide-In 2 Option-ROM		[Disabled]			
Power Loss Control		[Turn On]			
v02.59 (C)Copyright 1985-2005, American Megatrends, Inc.					

### Boot Device Priority Settings

Boot Setting	Description	Setting Options	Effect
<b>Boot Priority Selection</b>	You can define the drive used to boot up the machine.	Device based	Only devices that are recognized by the system are listed. You can change the sequence of items in the device list.
		Type based	You can change the sequence of items in the device list. You can add to the list device types that are not connected.
<b>1st Boot Device</b>	Use this option to define the boot drive.	Disabled, Primary Master, Primary Slave, Secondary Slave, Legacy Floppy, USB Floppy, USB CDROM, USB Removable Device, Onboard LAN, External LAN, PCI Mass Storage, PCI SCSI Card, Any PCI, BEV Device, Third Slave, Local BEV ROM	Select the desired boot sequence.
<b>2nd Boot Device</b>			
<b>3rd Boot Device</b>			
<b>4th Boot Device</b>			
<b>5th Boot Device</b>			
<b>6th Boot Device</b>			
<b>7th Boot Device</b>			
<b>8th Boot Device</b>			

## Boot Settings Configuration

Boot Setting	Description	Setting Options	Effect
<b>Quick Boot</b>	This function reduces the boot time by skipping some POST procedures.	Disabled	Disables this function.
		Enabled	Enables this function.
<b>Quiet Boot</b>	Determines if POST message or OEM logo (default = black background) is displayed.	Disabled	POST message display.
		Enabled	OEM logo display instead of POST message.
<b>Automatic Boot List Retry</b>	With this option, the operating system attempts to automatically restart following startup failure.	Disabled	Disables this function.
		Enabled	Enables this function.
<b>Add On ROM Display Mode</b>	Sets the display mode for ROM (during the boot procedure).	Force BIOS	Displays an additional BIOS part.
		Keep Current	Displays BIOS information.
<b>Hold On Errors</b>	This option sets whether the system should pause the Power On Self Test (POST) when it encounters an anomaly.	Disabled	The system does not pause. Ignores all anomalies.
		Enabled	System pause. The system pauses every time an anomaly is encountered.
<b>Hit 'DEL' Message Display</b>	You can define to display the "Hit 'DEL' Message" on startup. <b>NOTE:</b> When Quiet Boot is enabled, the message will not display.	Disabled	The message does not displayed.
		Enabled	The message will display.
<b>Interrupt 19 Capture</b>	Controls BIOS interrupt.	Disabled	Disables this function.
		Enabled	Enables this function.
<b>PXE Boot to LAN (ETH1)</b>	Enables/disables the ability to boot from LAN (ETH1).	Disabled	Disables this function.
		Enabled	Enables this function.
<b>Slide-In 2 Optional ROM</b>	Enables/disables optional ROM for a slide-in 2 drive.	Disabled	Disables this function.
		Enabled	Enables this function.
<b>Power Loss Control</b>	Determines if the system turns on/off following power loss.	Remain Off	Remains off
		Turn On	Powers on
		Last State	Enables the previous state.

## Security Menu

### Security Menu

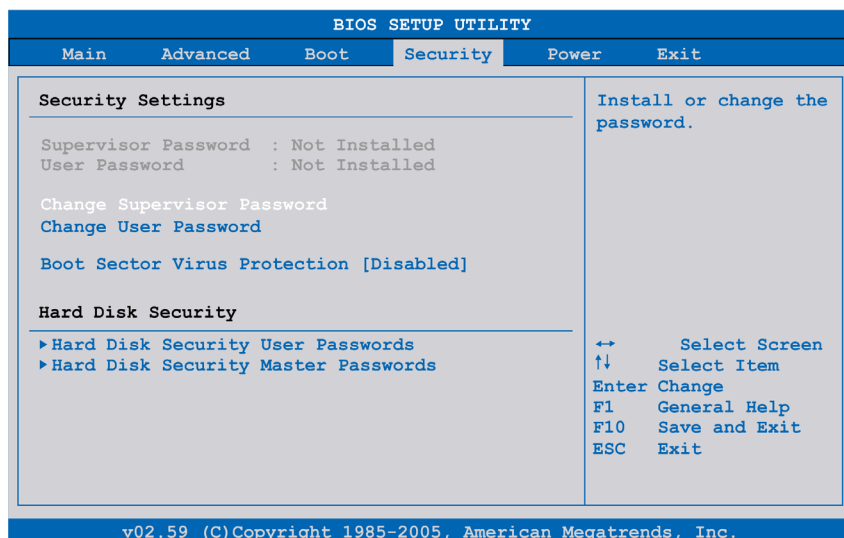

The following table shows the **Security** menu setting options:

BIOS Setting	Description	Setting Options	Effect
<b>Supervisor Password</b>	Displays whether or not a supervisor password has been set.	None	-
<b>User Password</b>	Displays whether or not a user password has been set.	None	-
<b>Change Supervisor Password</b>	Enter/change the supervisor password. A supervisor password is necessary to edit BIOS settings.	Enter	Enter password.
<b>Change User Password</b>	Enter/change a user password. A user password allows the user to edit certain BIOS settings.	Enter	Enter password.
<b>Boot Sector Virus Protection</b>	With this option, a warning is issued when the boot sector is accessed through a program or virus. <b>NOTE:</b> With this option, only the boot sector, not the entire hard drive, is protected.	Disabled	Disables this function.
		Enabled	Enables this function.
<b>Hard Disk Security User Password</b>	You can create the hard disk security user password here.	Enter	Opens submenu ( <i>see page 118</i> ).
<b>Hard Disk Security Master Password</b>	You can create the hard disk security master password here.	Enter	Opens submenu ( <i>see page 118</i> ).

### Hard Disk Security User Passwords

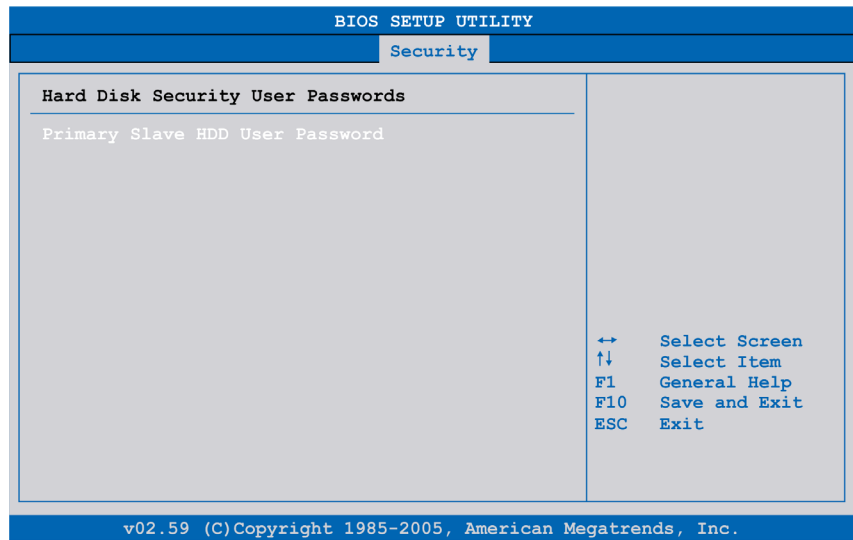

BIOS Setting	Description	Setting Options	Effect
<b>Primary Slave HDD User Password</b>	With a valid user password, you can change or configure hard drives without rebooting the device. A user password allows the user to edit specific BIOS settings.	Enter	Enter password.

### Hard Disk Security Master Passwords

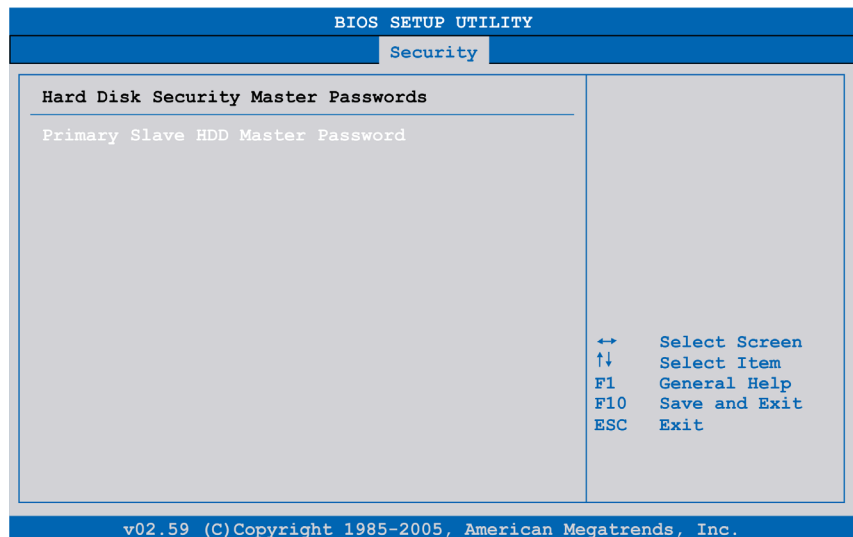

BIOS Setting	Description	Setting Options	Effect
<b>Primary Slave HDD Master Password</b>	With a valid user password, you can change or configure hard drives without rebooting the device.	Enter	Enter password.

## Exit Menu

### Exit Menu

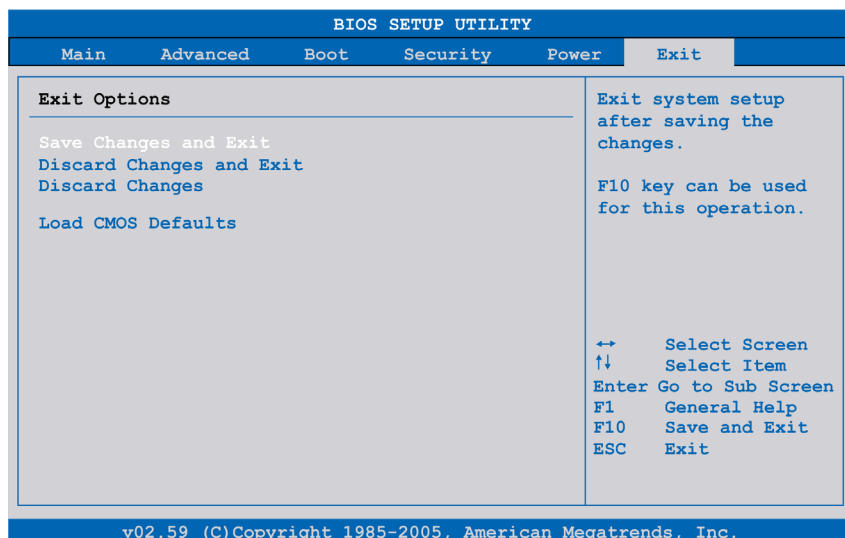

The following table gives the **Exit** menu setting options:

BIOS Setting	Description	Setting Options	Effect
<b>Save Changes and Exit</b>	Displays a confirmation message box. On confirming you want to save changes to the BIOS settings, saves the new settings to CMOS, and restarts the system.	OK / Cancel	-
<b>Discard Changes and Exit</b>	Exits the BIOS settings without making any changes, and restarts the system.	OK / Cancel	-
<b>Discard Changes</b>	Restores the previously saved BIOS settings and discards any changes that were made during the current session.	OK / Cancel	-
<b>Load CMOS Defaults</b>	Loads the CMOS default values, defined by the DIP switch settings. This command loads CMOS default values for all BIOS configurations.	OK / Cancel	-

### BIOS Default Settings

The CMOS profile switches, located on the front side of the unit near the LEDs, are used to load pre-defined BIOS profile settings, which are based on the position of the switches.

The switch positions at delivery represents the BIOS default values and should not be changed.





# Hardware Modifications

# 8

---

## Subject of this Chapter

This chapter is about the hardware modifications for the Industrial Personal Computer.

You can use optional units, Main Memory and CF Cards manufactured by Pro-face, as well as commercial devices and boards with this product.

## What's in this Chapter?

This chapter contains the following topics:

Topic	Page
Before Modifications	122
Uninterruptible Power Supply (UPS)	124
PCI / PCIe Card Installation	131
Compact Flash (CF) Card Installation and Removal	135

## Before Modifications

### Overview

 <b>DANGER</b>
<b>HAZARD OF ELECTRIC SHOCK, EXPLOSION OR ARC FLASH</b>
<ul style="list-style-type: none"><li>● Remove all power from the device before removing any covers or elements of the system, and prior to installing or removing any accessories, hardware, or cables.</li><li>● Unplug the power cable from both the Industrial Personal Computer and the power supply.</li><li>● Always use a properly rated voltage sensing device to confirm power is off.</li><li>● Replace and secure all covers or elements of the system before applying power to the unit.</li><li>● Use only the specified voltage when operating the Industrial Personal Computer. The AC unit is designed to use 100...240 Vac input. The DC unit is designed to use 24 Vdc. Always check whether your device is AC or DC powered before applying power.</li></ul>
<b>Failure to follow these instructions will result in death or serious injury.</b>

 <b>DANGER</b>
<b>EXPLOSION HAZARD</b>
<ul style="list-style-type: none"><li>● Always confirm the ANSI/ISA 12.12.01 and CSA C22.2 N°213 hazardous location rating of your device before installing or using it in a hazardous location.</li><li>● To power on or power off a Industrial Personal Computer installed in a Class I, Division 2 hazardous location, you must either:<ul style="list-style-type: none"><li>● Use a switch located outside the hazardous environment, or</li><li>● Use a switch certified for Class I, Division 1 operation inside the hazardous area.</li></ul></li><li>● Do not disconnect equipment unless power has been switched off or the area is known to be non-hazardous. This applies to all connections including power, ground, serial, parallel, and network connections.</li><li>● Never use unshielded / ungrounded cables in hazardous locations.</li><li>● Use only non-incendive USB configuration.</li><li>● When enclosed, keep enclosure doors and openings closed at all times to avoid the accumulation of foreign matter inside the workstation.</li></ul>
<b>Failure to follow these instructions will result in death or serious injury.</b>

During operation, surface temperatures of the heat sink may reach 70 °C (158 °F).

 <b>WARNING</b>
<b>RISK OF BURN</b>
Do not touch the surface of the heat sink during operation.
<b>Failure to follow these instructions can result in death, serious injury, or equipment damage.</b>

## CAUTION

### **OVERTORQUE AND LOOSE HARDWARE**

- Do not exert more than 0.5 N•m (4.5 lb-in) of torque when tightening the installation fastener, enclosure, accessory, or terminal block screws. Tightening the screws with excessive force can damage the plastic casing of the Industrial Personal Computer.
- When installing or removing screws, ensure that they do not fall inside the Industrial Personal Computer chassis.

**Failure to follow these instructions can result in injury or equipment damage.**

## CAUTION

### **STATIC SENSITIVE COMPONENTS**

Industrial Personal Computer internal components, including accessories such as RAM modules and expansion boards, can be damaged by static electricity.

- Keep static-producing materials (plastic, upholstery, carpeting) out of the immediate work area.
- Do not remove ESD-sensitive components from their anti-static bags until you are ready to install them.
- When handling static-sensitive components, wear a properly grounded wrist strap (or equivalent).
- Avoid unnecessary contact with exposed conductors and component leads with skin or clothing.

**Failure to follow these instructions can result in injury or equipment damage.**

## Uninterruptible Power Supply (UPS)

### Overview

The Uninterruptible Power Supply (UPS) option is only available for DC Industrial Personal Computer. The following figure shows a Industrial Personal Computer equipped with the UPS option:

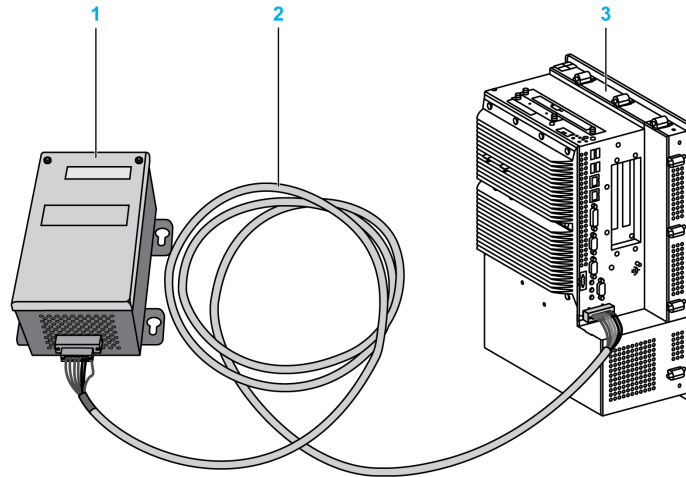

- 1 UPS battery unit
- 2 UPS connection cable 3 m (9.84 ft)
- 3 Industrial Personal Computer with UPS Interface Board (pre-installed)

#### NOTE:

When using a model with an integrated UPS module, connect the UPS battery unit before starting up the Industrial Personal Computer. If the Industrial Personal Computer is started before the UPS battery Unit is connected, a system error will occur and the buzzer will sound, so please use caution.

The main features of the UPS option are:

- Long-lasting, maintenance-free rechargeable batteries
- Communication via integrated interfaces
- Temperature sensor
- Deep discharge protection

### UPS Principle

With the optionally integrated UPS, the Industrial Personal Computer system completes write operations even after a power loss. When the UPS detects a power loss, it switches to battery operation immediately without interruption. This means that all running programs are ended properly by the UPS software. This prevents the possibility of inconsistent data.

#### NOTE:

- This function is only available if the UPS is configured and its driver is activated (see page 148).
- The monitor is not handled by the UPS and will shut off when the power fails.

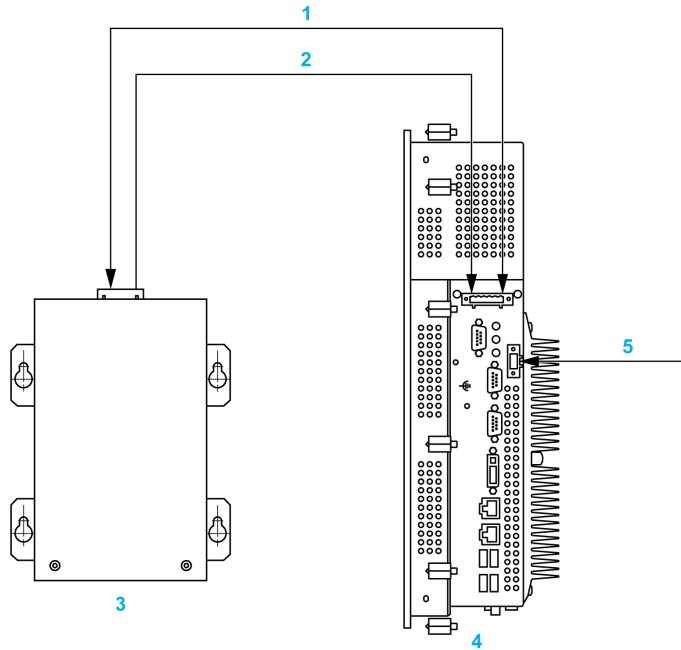

- 1 Battery / Load mode
- 2 Temperature
- 3 UPS battery unit
- 4 Industrial Personal Computer with integrated UPS module
- 5 Supply voltage +24 Vdc

### Integrated UPS Module Description

The following table gives the technical data of the UPS module integrated in the Industrial Personal Computer with the UPS option:

Features	Values
Switching Threshold Mains / Battery Operation	15 / 13 V
Mains Failure Bridge-over Time	Max. 20 min at 150 W load
Charging Current	Max. 0.5 A
Deep Discharge Protection	At 10 V on the battery unit
Short Circuit Protection	No
Power Requirements	Max. 7.5 W
Status Indicators	Via the system monitor ( <i>see page 144</i> )
Configuration	Via the system monitor settings ( <i>see page 148</i> )

**UPS Battery Unit Description**

The UPS battery unit is subject to wear and should be replaced regularly (at least following the specified lifespan).

The following figure shows the connector of the UPS battery unit:

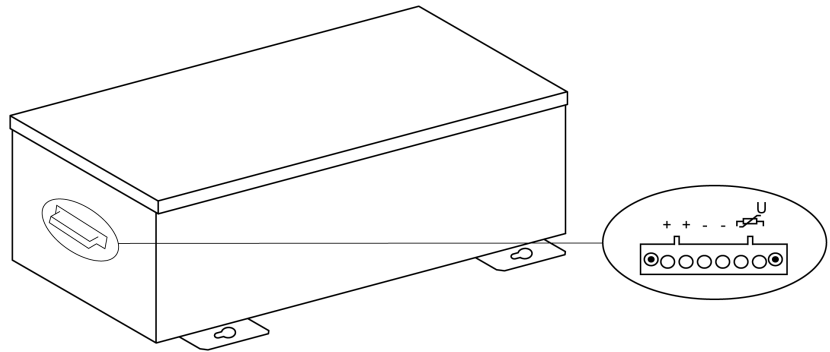

Features	Values
Battery: Type Method	Energys Cyclon 12 V 5 Ah (6 connected in series) Single cell (X cell)
Rated Voltage	12 V
Operating Current	Max. 8 A
Deep Discharge Voltage	10 V
Temperature Sensor	NTC resistance
Weight	Approx. 3.2 kg (7.05 lbs)
Ambient Temperature: Operation Storage Transport	- 40 to + 80 °C (- 40 °F to + 176 °F) - 65 to + 80 °C (- 85 °F to + 176 °F) - 65 to + 80 °C(- 85 °F to + 176 °F)
Relative Humidity: Operation Storage Transport	5...95%, non-condensing 5...95%, non-condensing 5...95%, non-condensing
Altitude	Max. 3000 meters (9843 feet)
Lifespan	10 years at 25 °C (77 °F) (up to 80% battery capacity)
Maintenance Interval (During Storage)	Charge once every 6 months
Battery Charging Time at Storage 0 %	15 hours

The following figure shows the dimensions of the UPS battery unit:

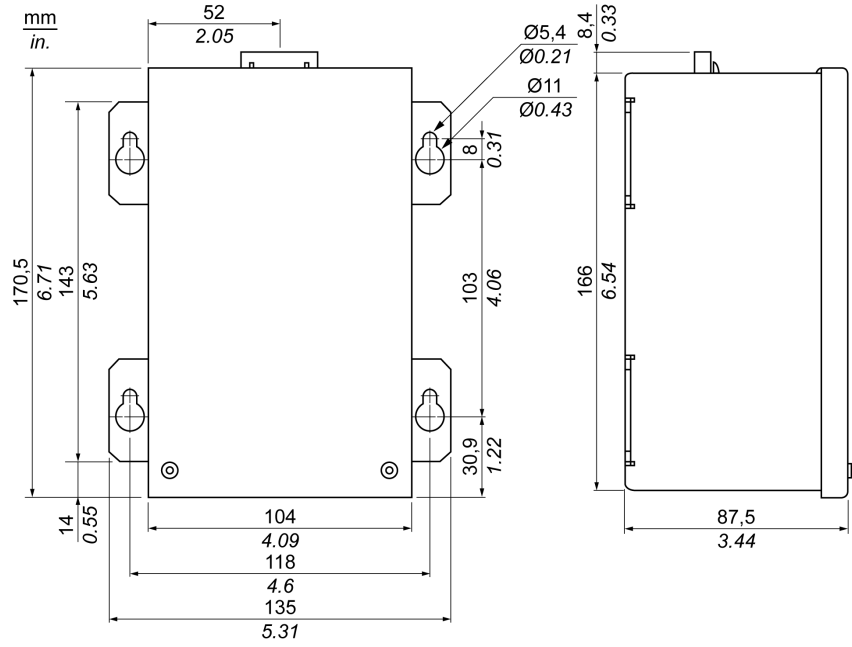

**Years to 80% of battery capacity (guide of the battery lifespan when applying current)**

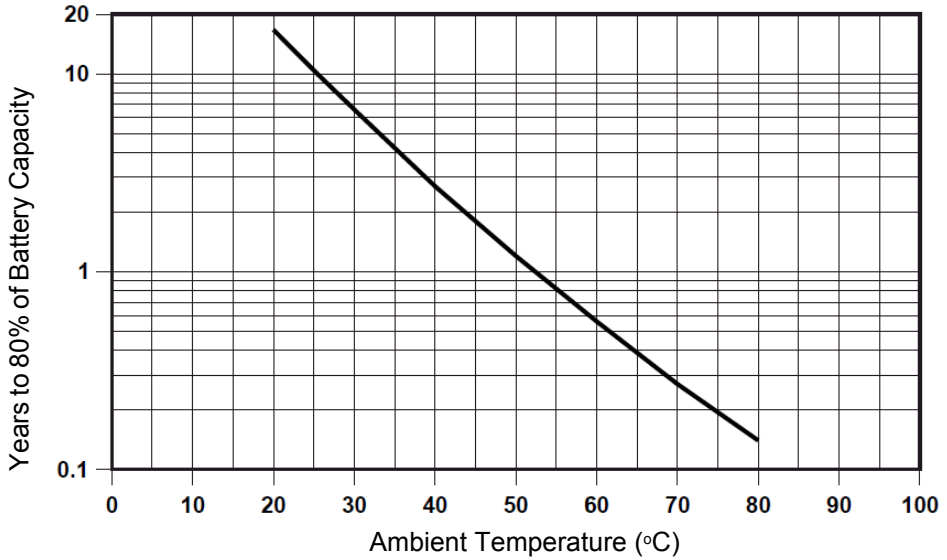

**Diagrams of the Temperature and Lifespan to 20 % of Battery Capacity (guide of the battery lifespan when storing)**

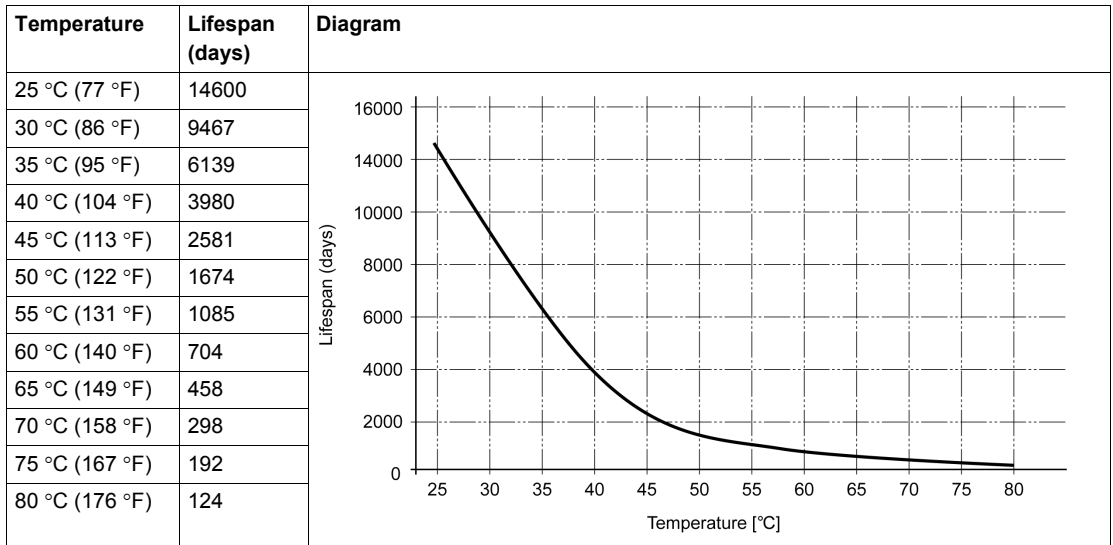



### Deep Discharge Cycles

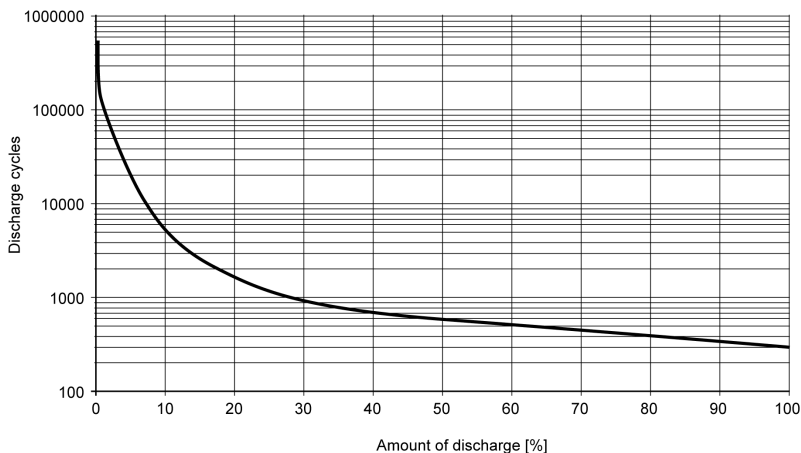

### UPS Connection Cable

The UPS connection cable has two different shapes of 6-pin connectors to help prevent a cable connector from being inserted in the incorrect connector (UPS battery unit or Industrial Personal Computer side):



- 1 6-pin plug connector
- 2 6-pin socket connector

The following table gives the technical data for the UPS connection cable:

Features	Values
Length	3 m (9.843 ft)
Outer Diameter	8.5 mm ± 0.2 mm (0.33 in. ± 0.0078 in.)
Connector Type	6-pin plug connectors, tension clamp connection 6-pin socket connectors, tension clamp connection
Wire Cross Section Temperature Sensor Wire Voltage Wire	2 x 0.5 mm <sup>2</sup> (AWG 20) 4 x 2.5 mm <sup>2</sup> (AWG 13)
Line Resistance 0.5 mm <sup>2</sup> 2.5 mm <sup>2</sup>	Max. 39 Ω/km (63 Ω/mile) Max .7.98 Ω/km (13 Ω/mile)
Flex Radius Fixed Installation Free-moving	5 x wire cross-section 10 x wire cross-section
Temperature Range Operation Storage	- 5...+ 80 °C (23 ...176 °F) - 30...+ 80°C (- 22 ...176 °F)
Weight	Approx. 143 kg/km (230 kg/miles)

Features	Values
Materials	
Cable Shielding	Thermoplastic PVC-based material
Color	Window gray (similar to RAL 7040)
Peak Operating Voltage	12 Vdc
Testing AC Voltage	
Wire/wire	1500 V
Operating Voltage	Max. 300 V
Current Load	10 A at + 20 °C (10 A at + 68 °F)

**Mounting Instructions**

By integrating the charging circuit in the Industrial Personal Computer housing, installation is reduced to merely attaching the connection cable to the UPS battery unit mounted next to the Industrial Personal Computer.

Due to the construction of these batteries, you can store and operate the UPS battery unit in any position.

For mounting the UPS battery unit, use the following figure as the drilling template:

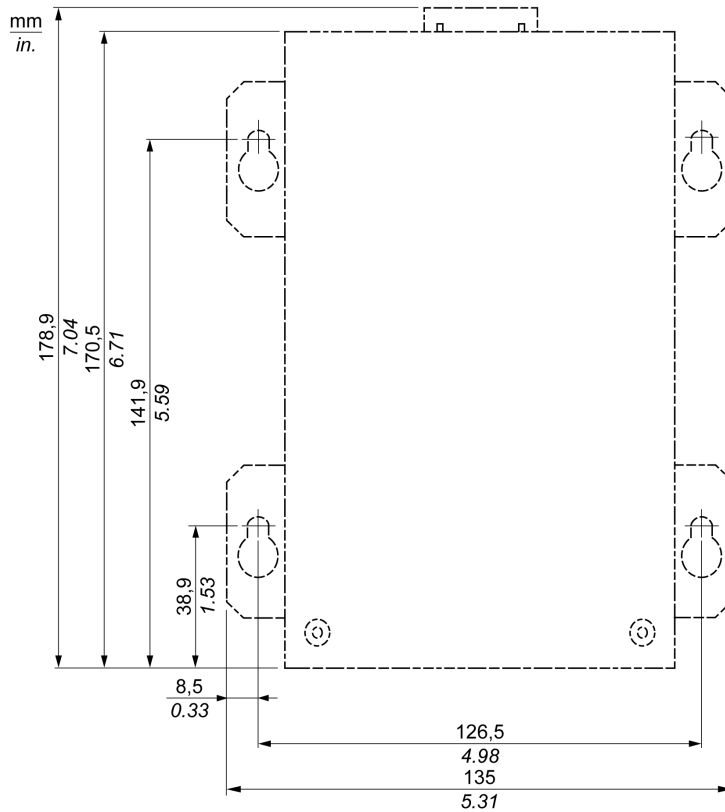

## PCI / PCIe Card Installation

### Overview

Before installing or removing a PCI / PCIe card, shut down Windows® in an orderly fashion and remove all power from the device.

### DANGER

#### HAZARD OF ELECTRIC SHOCK, EXPLOSION OR ARC FLASH

- Remove all power from the device before removing any covers or elements of the system, and prior to installing or removing any accessories, hardware, or cables.
- Unplug the power cable from both the Industrial Personal Computer and the power supply.
- Always use a properly rated voltage sensing device to confirm power is off.
- Replace and secure all covers or elements of the system before applying power to the unit.
- Use only the specified voltage when operating the Industrial Personal Computer. The AC unit is designed to use 100...240 Vac input. The DC unit is designed to use 24 Vdc. Always check whether your device is AC or DC powered before applying power.

**Failure to follow these instructions will result in death or serious injury.**

### PCI / PCIe Cards with Cables

When using a PCI / PCIe card with an external cable attached, install a clamp or other device to secure the cable.

### WARNING

#### EQUIPMENT DISCONNECTION OR UNINTENDED EQUIPMENT OPERATION

- Ensure that power, communication, and accessory connections do not place excessive stress on the ports. Consider the vibration environment when making this determination.
- Securely attach power, communication, and external accessory cables to the panel or cabinet.
- Use only commercially available USB cables.

**Failure to follow these instructions can result in death, serious injury, or equipment damage.**

### PCI or PCIe Card Dimensions

Depending on the bus type, you can use standard PCI 2.2 half-size cards or PCI Express (PCIe) half-size cards.

**NOTE:** PCI or PCIe cards cannot exceed the following dimensions.

The following figure shows the dimensions of the standard half-size PCI card:

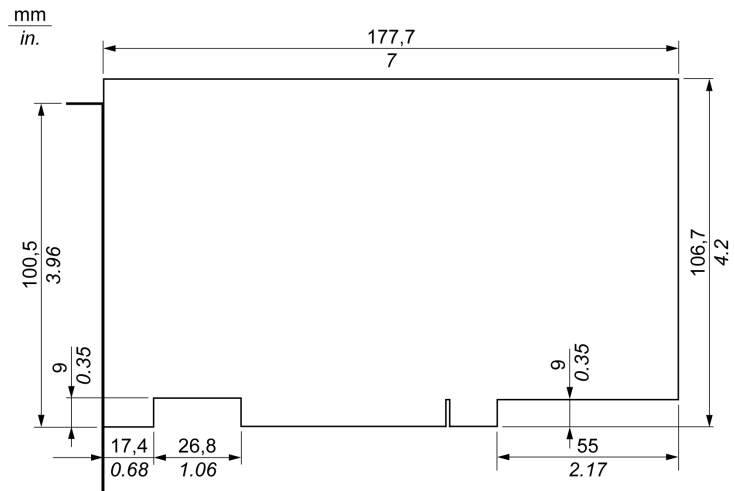

The following figure shows the dimensions of the standard half-size PCIe card:

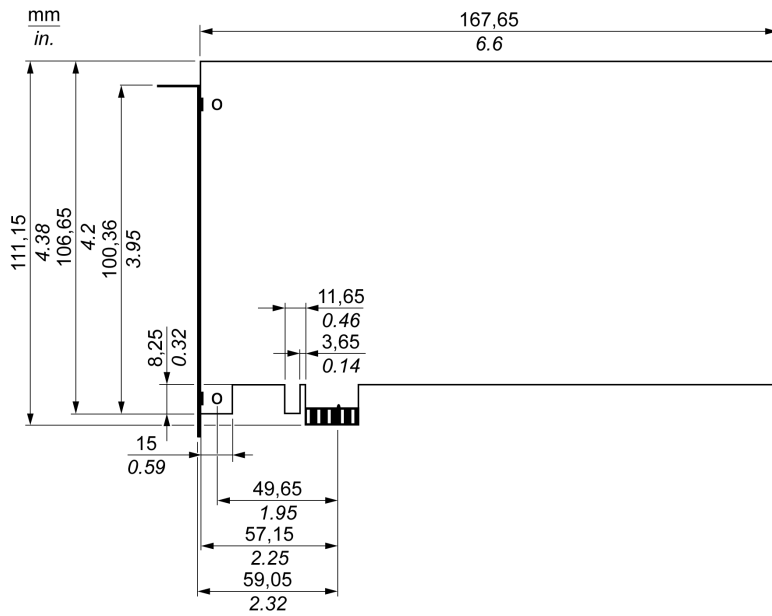

## PCI Slot Position

The following figure shows the PCI slot position:

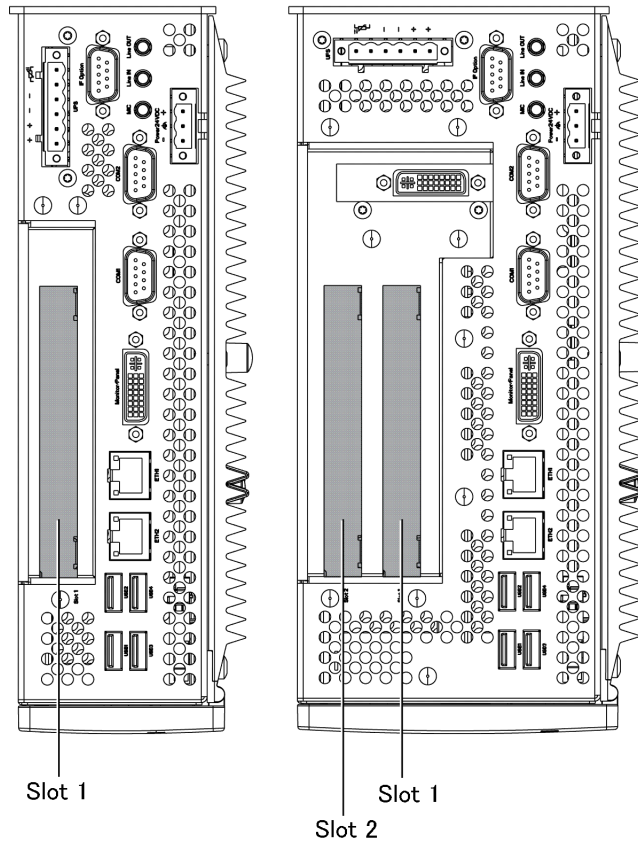

**NOTE:** Take into account the PCI/PCIe card type restriction according to the table below.

The following table provides an overview of the slots where inserting 64-bit cards is possible:

		Slot 1	Slot 2
1slot	1PCI	32-bit PCI	—
2slots	1PCI+1PCIe	32-bit or 64-bit PCI	PCIe
	2PCI	32-bit or 64-bit PCI	32-bit PCI

## PCI/PCIe Card Installation

### **NOTICE**

#### **ELECTROSTATIC DISCHARGE**

Take the necessary protective measures against electrostatic discharge before attempting to remove the Industrial Personal Computer cover.

**Failure to follow these instructions can result in equipment damage.**

**NOTE:** Be sure to remove all power before attempting this procedure.

The table below describes how to install a PCI or PCIe card:

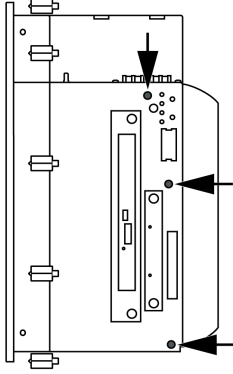
Step	Action
1	Disconnect the power cord to the Industrial Personal Computer.
2	Touch the housing or ground connection (not the power supply) to discharge any electrostatic charge from your body.
3	Remove the 3 Torx screws of the Industrial Personal Computer: 
4	Remove the side cover by lifting it backward.
5	Unscrew the screw from the empty panel and remove the blank panel. Insert the PCI/PCIe board into the expansion board connector and secure in place using the filler panel screw. <b>NOTE:</b> The recommended torque to tighten these screws is 0.5 N•m (4.5 lb-in).
6	Replace the side cover and secure it by inserting the Torx screws.

**⚠ CAUTION**

**OVERTORQUE AND LOOSE HARDWARE**

- Do not exert more than 0.5 N•m (4.5 lb-in) of torque when tightening the installation fastener, enclosure, accessory, or terminal block screws. Tightening the screws with excessive force can damage the plastic casing of the Industrial Personal Computer.
- When installing or removing screws, ensure that they do not fall inside the Industrial Personal Computer chassis.

**Failure to follow these instructions can result in injury or equipment damage.**

## Compact Flash (CF) Card Installation and Removal

### Preparing to Use a CF Card

The Industrial Personal Computer operating system views the CF Card as a hard disk. Proper handling and care of the CF Card helps extend the life of the Card. Familiarize yourself with the Card prior to attempting insertion or removal of the Card.

### DANGER

#### HAZARD OF ELECTRIC SHOCK, EXPLOSION OR ARC FLASH

- Remove all power from the device before removing any covers or elements of the system, and prior to installing or removing any accessories, hardware, or cables.
- Unplug the power cable from both the Industrial Personal Computer and the power supply.
- Always use a properly rated voltage sensing device to confirm power is off.
- Replace and secure all covers or elements of the system before applying power to the unit.
- Use only the specified voltage when operating the Industrial Personal Computer. The AC unit is designed to use 100...240 Vac input. The DC unit is designed to use 24 Vdc. Always check whether your device is AC or DC powered before applying power.

**Failure to follow these instructions will result in death or serious injury.**

### CAUTION

#### COMPACT FLASH CARD DAMAGE AND DATA LOSS

- Remove all power before making any contact with an installed CF Card.
- Use only CF Cards manufactured by Pro-face. The performance of the Industrial Personal Computer has not been tested using CF Cards from other manufacturers.
- Confirm that the CF Card is correctly oriented before insertion.
- Do not bend, drop, or strike the CF Card.
- Do not touch the CF Card connectors.
- Do not disassemble or modify the CF Card.
- Keep the CF Card dry.

**Failure to follow these instructions can result in injury or equipment damage.**

### Inserting the CF Card

The procedure below describes how to insert the CF Card.

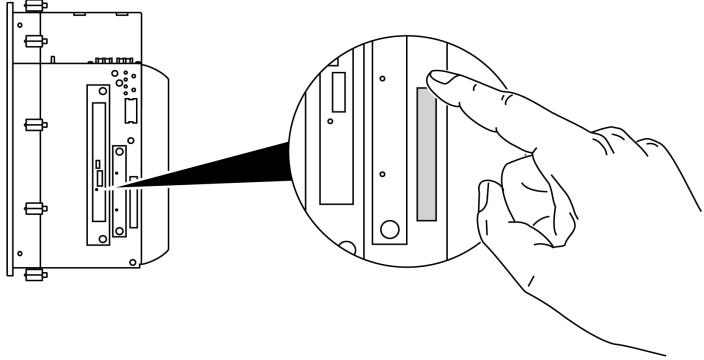
Step	Action
1	Shut down Windows® in an orderly fashion and remove all power from the device.
2	Remove the CF Card cover: 
3	Insert the CF Card firmly into the CF Card slot, and check that the eject button pops out.
4	Replace the CF Card cover.

### Removing the CF Card

The procedure below describes how to remove the CF Card.

Step	Action
1	Shut down Windows® in an orderly fashion and remove all power from the device.
2	Remove the CF Card cover ( <i>see page 136</i> ).
3	Press the eject button all the way to remove the CF Card from the CF Card slot. <b>NOTE:</b> The best way to do this is to use a pointed object such as a small screwdriver.
4	After removing the CF Card, replace the CF Card cover.

### Data Writing Limitation

The CF Card is limited to approximately 100,000 write operations. Back up all CF Card data regularly to another storage media.



# Installation



---

## Subject of this Part

This part describes the product installation.

## What's in this Part?

This part contains the following chapters:

Chapter	Chapter Name	Page
9	System Monitor	139
10	Maintenance	149



# System Monitor

# 9

---

## Subject of this Chapter

This chapter describes the system monitor features of the Industrial Personal Computer.

## What's in this Chapter?

This chapter contains the following topics:

Topic	Page
System Monitor Interface	140
System Monitor Setting	146

## System Monitor Interface

### Overview

The System Monitor software enables you to monitor the following system parameters:

- **Temperature**
- **Fan**
- **SMART**
- **Battery**

Depending on the configuration (see page 146), if thresholds are exceeded the System Monitor Software alerts via a popup message (see page 144), sound, buzzer and an entry in the windows event log. You can configure (see page 148) a system shutdown when an alarm occurs.

### Accessing the System Monitor

The procedure below shows how to access the System Monitor interface:

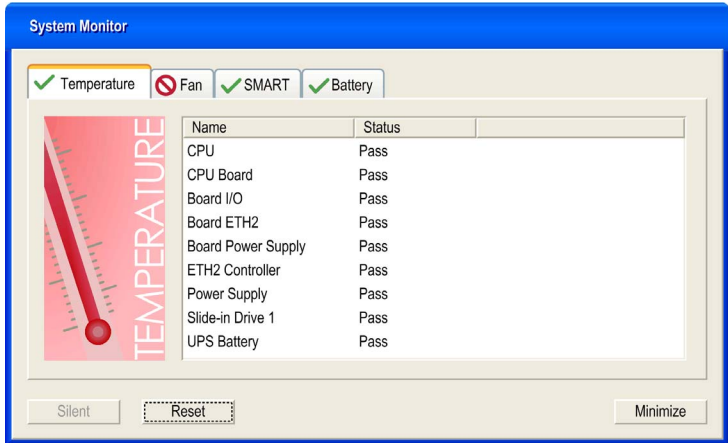
Step	Action
1	Start the Industrial Personal Computer operating system.
2	<p>In the task bar, double-click the following icon:</p>  <p><b>NOTE:</b> If you cannot see the icon in the task bar, launch the System Monitor software by double-clicking the <i>SysMonGui.exe</i> file located in the following path: <i>C:\Utility\Systemon</i>.</p> <p>The following figure shows the System Monitor main window:</p> 

### System Monitor Interface Description

The System Monitor interface shows all possible parameters and their actual status in system parameter tabs.

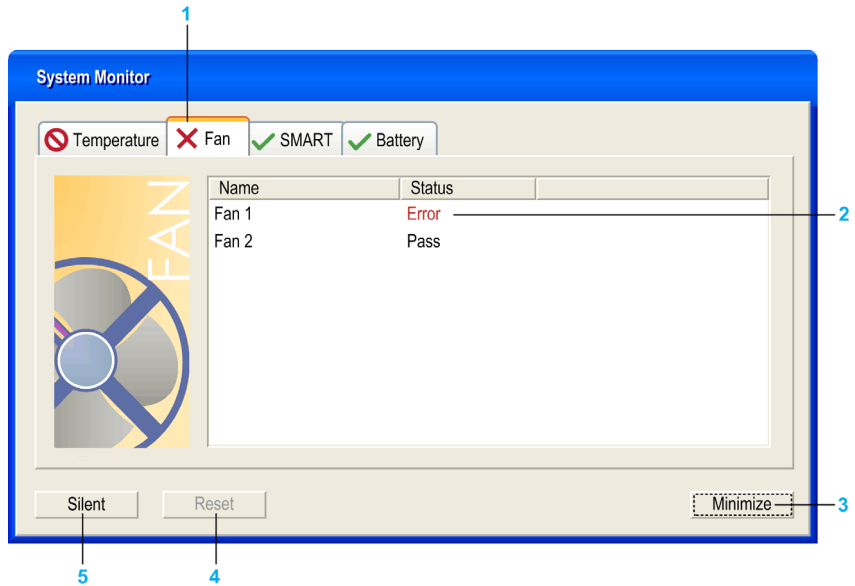

- 1 Icon specific tab (Refer to the table below).
- 2 Item name and status
- 3 Minimize the System Monitor to the system tray.
- 4 Resets alarmed item.
- 5 Disable buzzer and sound. Only active when sound or buzzer is playing.

The following table describes the icons of the system parameter tab:

Icon	Status	Meaning
✓	Ok	No alarm detected
⊘	Disabled	The system parameter is not monitored.
✗	Alarm	At least one detected alarm.

### Temperature Status

The following figure shows the **Temperature** tab:

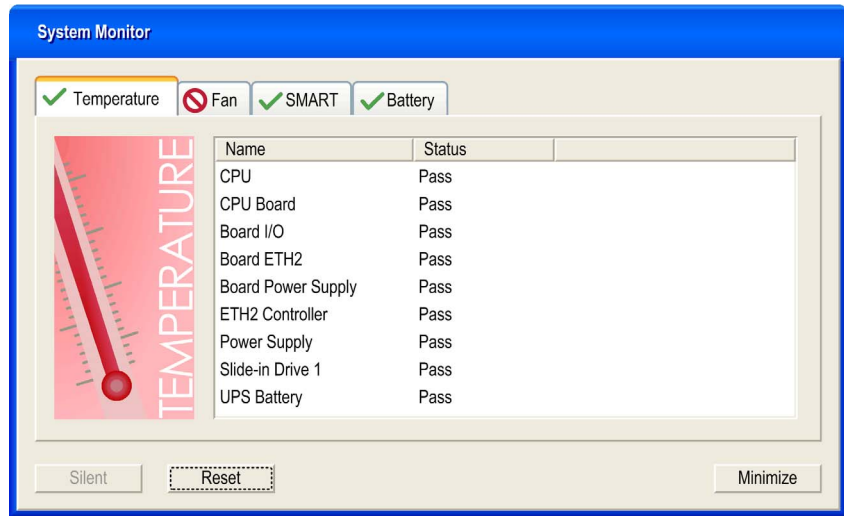

The following table describes the status messages of temperature parameters:

Status	Meaning
Pass	No alarm detected
Error	Alarm (limit exceeded)
Disabled	No alarm monitoring
***	Service is not running

### Fan Status

The following figure shows the **Fan** tab:

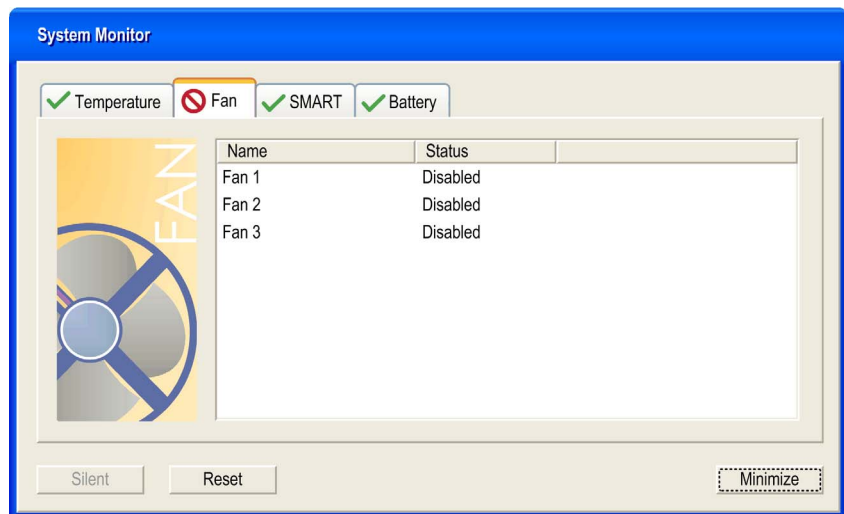

The following table describes the status messages of fan parameters:

Status	Meaning
Pass	No alarm detected
Error	Alarm (a fan does not function as expected)

Status	Meaning
Disabled	No alarm monitoring
***	Service is not running

## SMART Status

The **SMART** status monitors the hard disk.

The following figure shows the **SMART** tab:

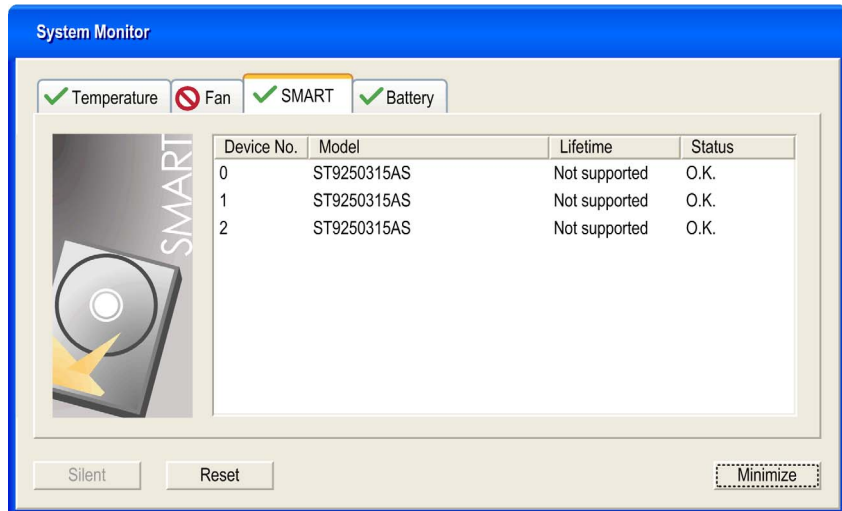

**NOTE:** In addition to the **Status** column, the **SMART** tab shows a column for the device lifetime. If the device has lifetime support, a **Lifetime** value in percent with a bar bargraph is displayed, otherwise "**Not supported**" is shown.

The following table describes the status message of the Industrial Personal Computer drives:

Status	Meaning
O.K.	No alarm detected
Alert	Failure reported by SMART or disk life-time reached
Disabled	No alarm monitoring
***	Service is not running

## Battery Status

The following figure shows the **Battery** tab:

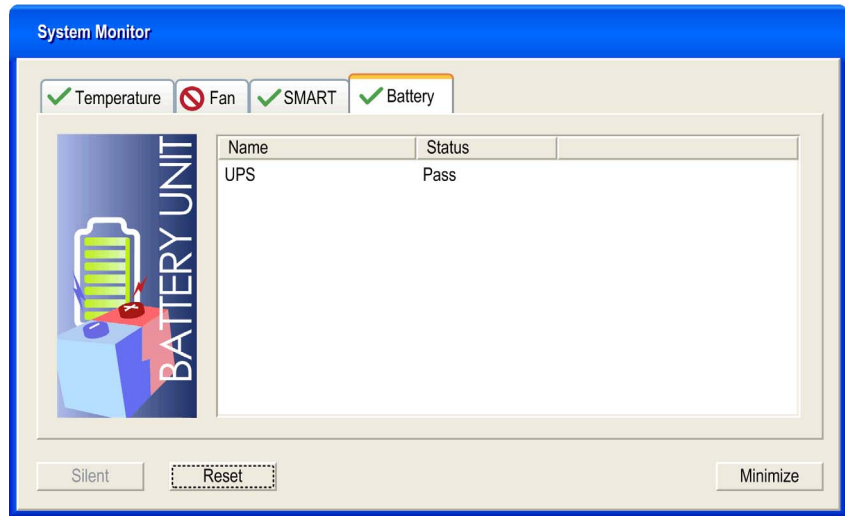

The following table describes the status message of the battery parameters:

Status	Meaning
Pass	No alarm detected.
Error	Battery unit detected a failure, e.g. battery is disconnected.
On Battery	Power failure - system is running on battery.
Low Battery	Battery level is critically low.
No Battery	No battery connected.
Low Battery Shutdown	Power failure - system is running on battery and battery level is critically low → system shutdown is initiated.
Disabled	No alarm monitoring.
***	Service is not running.

## Popup Window Description

When an alarm is detected the following popup window is displayed:

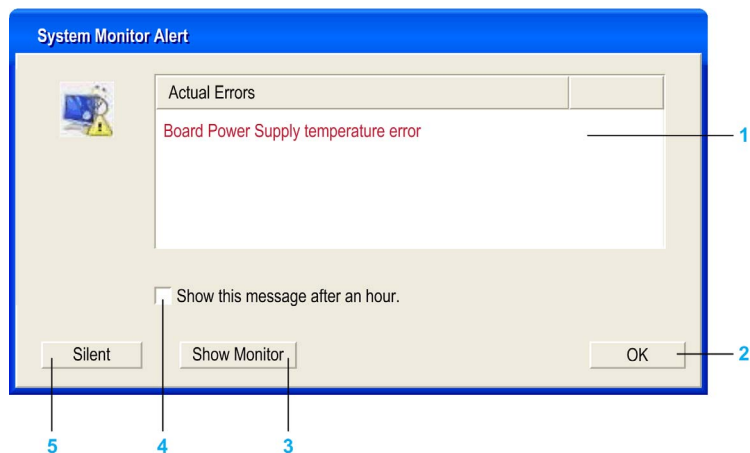

1 Shows the alarm or item that can be reset.



- 2 Closes the System Monitor Alert window.
- 3 Shows the main window.
- 4 If the check box is selected, closes the window for one hour even though the alarm is active. (A new alarm shows the window again).
- 5 Disable buzzer and sound. Only active when sound or buzzer is playing.

## System Monitor Setting

### Overview

You can set the System Monitor parameters and specify the type of alarm in the System Monitor applet in the Windows Control Panel.

Each system parameter has its own tab.

Use the following dialog box tabs to display the monitoring parameters and setup the various elements to monitor.

### Temperature - System Monitor Properties

The screenshot below shows the **Temperature** tab:

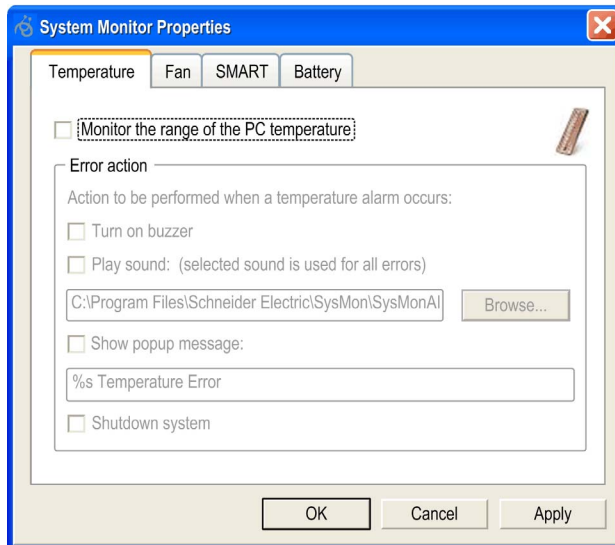

Field	Description
<b>Monitor the range of the PC temperature</b>	Select this check box to enable and begin monitoring the PC temperature. When enabled ( <i>see page 148</i> ), set the <b>Error action</b> .

### Fan - System Monitor Properties

**NOTE:** Only available for Core 2 Duo P8400 Pre-installed Model.

The screenshot below shows the **Fan** tab:

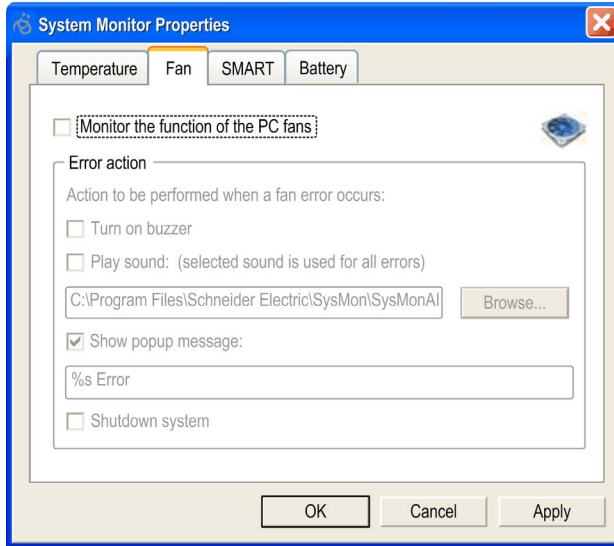

Field	Description
<b>Monitor the function of the PC fans</b>	Select this check box to enable and begin monitoring the function of fans. When enabled (see page 148), set the <b>Error action</b> .

### SMART - System Monitor Properties

The screenshot below shows the **SMART** tab:

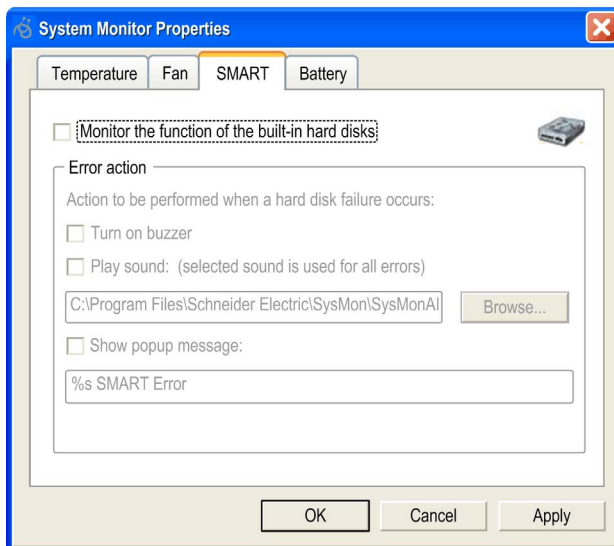

Field	Description
<b>Monitor the function of the built-in hard disks</b>	Select this check box to enable and begin monitoring the built-in hard disks. When enabled (see page 148), set the <b>Error action</b> .

**Battery - System Monitor Properties**

**NOTE:** Only available for the models with UPS Interface Board Products.

The screenshot below shows the **Battery** tab:

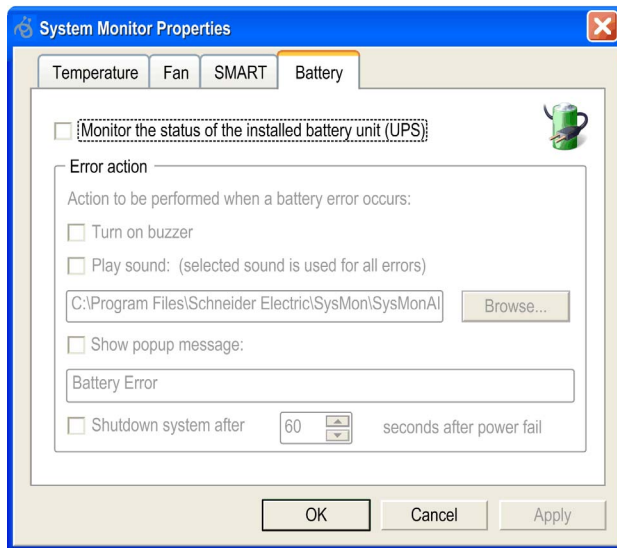

Field	Description
<b>Monitor the status of the installed battery unit (UPS)</b>	Select this check box to enable and begin monitoring the installed UPS battery unit. When enabled (see page 148), set the <b>Error action</b> .

**Error Action Configuration**

Field	Description
<b>Turn on buzzer</b>	Select this check box to enable the buzzer.
<b>Play sound</b>	Select this check box to enable the sound that is used for all detected errors. Specify the sound file path ( <b>Browse...</b> button).
<b>Show popup message</b>	When this check box is selected, status messages are displayed in the form of a popup.
<b>Shutdown system</b>	If you want the system to stop when an error is detected, select this check box. Not available in <b>SMART</b> tab.

# Maintenance

# 10

---

## Subject of this Chapter

This chapter covers maintenance of the Industrial Personal Computer.

## What's in this Chapter?

This chapter contains the following topics:

Topic	Page
Reinstallation Procedure	150
Regular Cleaning and Maintenance	151

## Reinstallation Procedure

### Introduction

In certain cases, it may be necessary to reinstall the operating system.

Precautions to be taken:

- Keep static-producing materials (plastic, upholstery, carpeting) out of the immediate work area.
- Do not remove ESD-sensitive components from their anti-static bags until you are ready to install them.
- When handling static-sensitive components, wear a properly grounded wrist strap (or equivalent).
- Avoid unnecessary contact with exposed conductors and component leads with skin or clothing.

### Before Reinstallation

Hardware required:

- Reinstallation DVD-ROM
- External DVD drive, compatible with DVD+R DL format, and with USB connection for Industrial Personal Computer without DVD drive.

Setting up the hardware:

- Shut down Windows® in an orderly fashion and remove all power from the device. Then, follow the applicable instructions described in *Uninterruptible Power Supply (UPS)* (see page 124).
- Disconnect all external peripherals.

**NOTE:** Save all important data on the hard drive or Compact Flash card (the reinstallation process will erase all data). The reinstallation process will return the computer to its factory settings.

### Reinstallation

Refer to the relevant procedure in "PS4000 Series Installation Guide" in a package.

## Regular Cleaning and Maintenance

### Introduction

Inspect the Industrial Personal Computer periodically to determine its general condition. For example:

- Are all power cords and cables connected properly? Have any become loose?
- Are all installation fasteners holding the unit securely?
- Is the ambient temperature within the specified range?
- Are there any scratches or traces of dirt on the installation gasket?

The following describes service/maintenance work which can be carried out by a trained, qualified user.

### **DANGER**

#### **HAZARD OF ELECTRIC SHOCK, EXPLOSION OR ARC FLASH**

- Remove all power from the device before removing any covers or elements of the system, and prior to installing or removing any accessories, hardware, or cables.
- Unplug the power cable from both the Industrial Personal Computer and the power supply.
- Always use a properly rated voltage sensing device to confirm power is off.
- Replace and secure all covers or elements of the system before applying power to the unit.
- Use only the specified voltage when operating the Industrial Personal Computer. The AC unit is designed to use 100...240 Vac input. The DC unit is designed to use 24 Vdc. Always check whether your device is AC or DC powered before applying power.

**Failure to follow these instructions will result in death or serious injury.**

### **DANGER**

#### **EXPLOSION HAZARD**

- Always confirm the ANSI/ISA 12.12.01 and CSA C22.2 N°213 hazardous location rating of your device before installing or using it in a hazardous location.
- To power on or power off a Industrial Personal Computer installed in a Class I, Division 2 hazardous location, you must either:
  - Use a switch located outside the hazardous environment, or
  - Use a switch certified for Class I, Division 1 operation inside the hazardous area.
- Do not disconnect equipment unless power has been switched off or the area is known to be non-hazardous. This applies to all connections including power, ground, serial, parallel, and network connections.
- Never use unshielded / ungrounded cables in hazardous locations.
- Use only non-incendive USB configuration.
- When enclosed, keep enclosure doors and openings closed at all times to avoid the accumulation of foreign matter inside the workstation.

**Failure to follow these instructions will result in death or serious injury.**

During operation, surface temperatures of the heat sink may reach 70 °C (158 °F).

<b>⚠ WARNING</b>
<b>RISK OF BURN</b>
Do not touch the surface of the heat sink during operation.
<b>Failure to follow these instructions can result in death, serious injury, or equipment damage.</b>

**Cleaning Solutions**

<b>⚠ CAUTION</b>
<b>HARMFUL CLEANING SOLUTIONS</b>
<ul style="list-style-type: none"> <li>Do not clean the unit or any component of the unit with paint thinner, organic solvents, or strong acids.</li> <li>Use only a mild soap or detergent that will not harm the polycarbonate material of the screen.</li> </ul>
<b>Failure to follow these instructions can result in injury or equipment damage.</b>

**Lithium Battery**

The Industrial Personal Computer contains one battery, which is needed for backing up:

- the real-time clock (RTC)
- CMOS data for BIOS settings

**NOTE:** The following characteristics, features and limits only apply to this accessory and can deviate from those specified for the entire device. For the device where this accessory is installed, refer to the data provided specifically for the device.

Features	Values
Capacity	950 mAh
Voltage	3 V
Self Discharge at 23 °C (73.4 °F)	< 1% per year
Storage Time	Maximum 3 years at 30 °C (86 °F)
<b>Environmental Characteristics</b>	
Storage Temperature	- 20...+60 °C (- 4...140 °F)
Relative Humidity	0...95% non-condensing

**Replacing the Lithium Battery**

<b>⚠ DANGER</b>
<b>HAZARD OF ELECTRIC SHOCK, EXPLOSION, OR ARC FLASH</b>
Read and understand the safety information in the Regular Cleaning and Maintenance section (see page 151) before attempting this procedure.
<b>Failure to follow these instructions will result in death or serious injury.</b>



 **DANGER**

**EXPLOSION, FIRE, OR CHEMICAL HAZARD**

- Replace lithium battery with identical type.
- Follow all lithium battery manufacturer's instructions.
- Do not recharge, disassemble, heat above 100 °C (212 °F), or incinerate.
- Use your hands or insulated tools to remove or replace the lithium battery.
- Maintain proper polarity when inserting and connecting a new lithium battery.
- Remove all replaceable batteries before discarding the Industrial Personal Computer.
- Recycle or properly dispose of used batteries.

**Failure to follow these instructions will result in death or serious injury.**

**NOTE:**

- The product design allows you to change the lithium battery with the Industrial Personal Computer either on or off.
- Saved settings will be restored when changing the lithium battery with the power turned off (as the settings are stored in non-volatile EEPROM). However, the date and time must be reset because this data is lost when changing the lithium battery.
- Only qualified personnel can change the lithium battery.

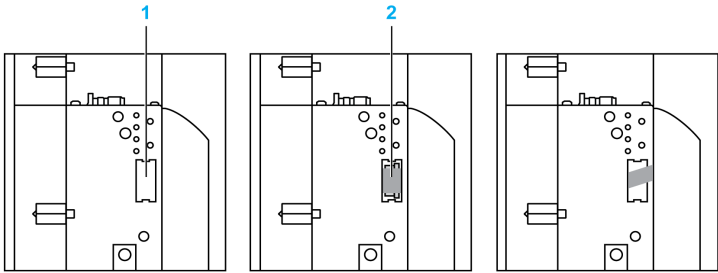
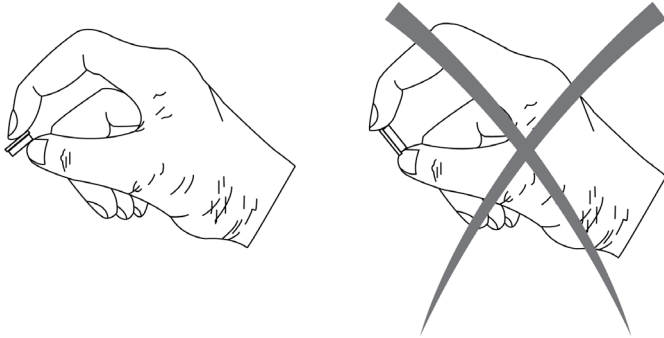
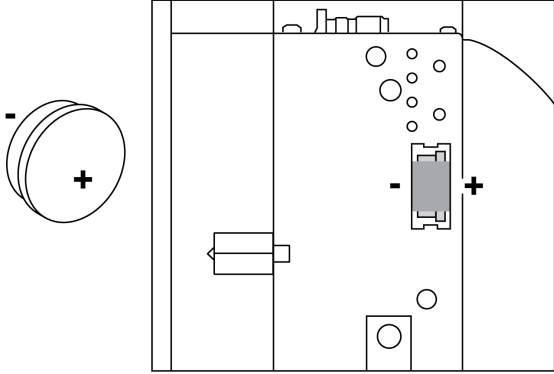
Step	Action
1	Disconnect the power supply to the Industrial Personal Computer.
2	Touch the housing or ground connection (not the power supply) to discharge any electrostatic charge from your body.
3	 <p>1 Remove the black plastic cover from the lithium battery compartment 2 Carefully pull out the lithium battery using removal strips</p>
4	<p>The lithium battery should not be held by its edges. Insulated tweezers may also be used for inserting the lithium battery.</p> 
5	<p>Insert the new lithium battery with correct polarity:</p> 

Step	Action
6	To make the next lithium battery change easier, be sure the removal strip is in place when inserting lithium battery.
7	Reconnect the power supply to the Industrial Personal Computer (plug in power cable and press power button).
8	You may need to reset the date and time in the BIOS settings.

**NOTE:** Replacement of the lithium battery in the Industrial Personal Computer other than with the type specified in this documentation may present a risk of fire or explosion.

## ⚠ WARNING

### IMPROPER LITHIUM BATTERY CAN PROVOKE FIRE OR EXPLOSION

Replace lithium battery only with identical type: PFXZPSBTLT1.

**Failure to follow these instructions can result in death, serious injury, or equipment damage.**

## Replacing the Fan

## ⚠ DANGER

### HAZARD OF ELECTRIC SHOCK, EXPLOSION, OR ARC FLASH

Read and understand the safety information in the Regular Cleaning and Maintenance section (*see page 151*) before attempting this procedure.

**Failure to follow these instructions will result in death or serious injury.**

The fans help keep the Industrial Personal Computer from overheating. If necessary to replace the fans, provide the fan kit (*see page 161*) and perform the following procedure:

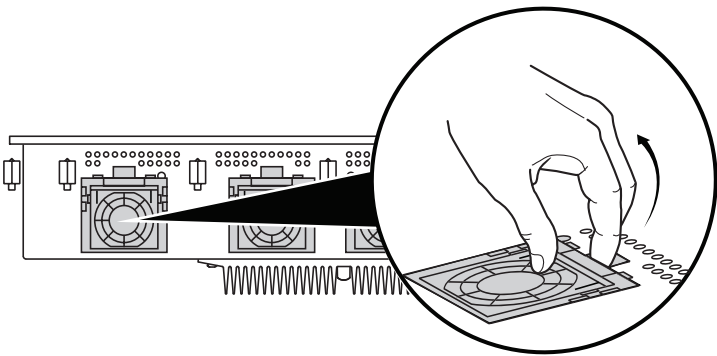
Step	Action
1	Disconnect the power supply to the Industrial Personal Computer.
2	Touch the housing or ground connection (not the power supply) to discharge any electrostatic charge from your body.
3	To remove the fan from the holder, press the snap arms inward: 

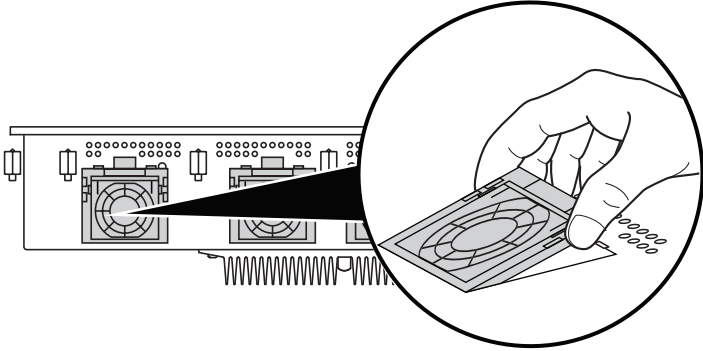
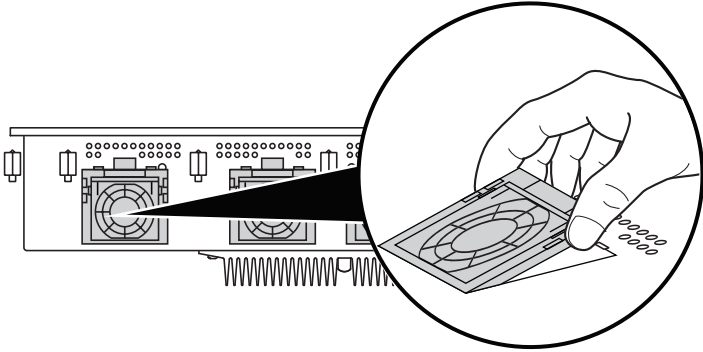
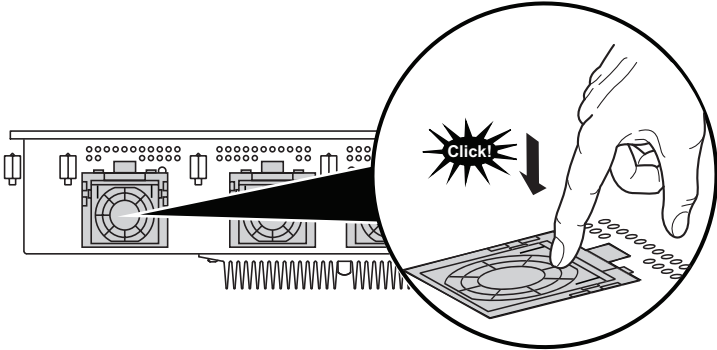
Step	Action
4	<p>Rotate upward the fan and carefully remove the fan from the Industrial Personal Computer:</p> 
5	<p>The fan kit contains two models of fans:</p> <ul style="list-style-type: none"> <li>● One with the connector at the right side</li> <li>● One with the connector at the left side</li> </ul> <p><b>NOTE:</b> Before reinstalling the fan, confirm that all fans you need are present in the fan kit and exempt of damage.</p>
6	<p>Before placing the fan, make sure that the correct fan is used. Place the fan on the Industrial Personal Computer and rotate the fan forward:</p> 
7	<p>Secure the fan by pushing down the locking mechanism until it clicks:</p> 

**Replacing the Fan Filter**

**⚠ DANGER**

**HAZARD OF ELECTRIC SHOCK, EXPLOSION, OR ARC FLASH**

Read and understand the safety information in the Regular Cleaning and Maintenance section (see page 151) before attempting this procedure.

**Failure to follow these instructions will result in death or serious injury.**

The fan filters are subject to wear, and should be checked with appropriate frequency to determine whether the air flow provides sufficient cooling. An exchange or cleaning of the filters is appropriate at that time.

The following procedure describes how to replace the fan filters:

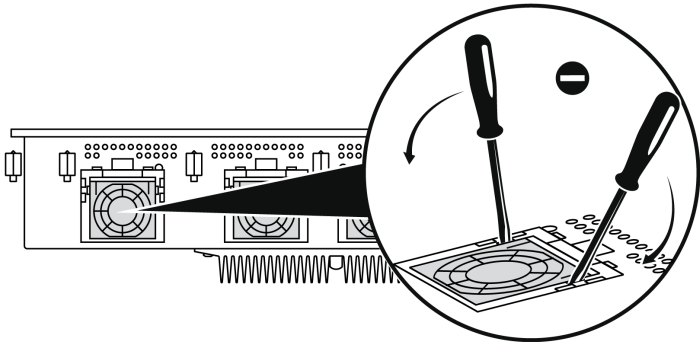
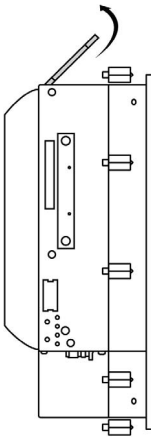
Step	Action
1	Disconnect the power supply to the Industrial Personal Computer.
2	Touch the housing or ground connection (not the power supply) to discharge any electrostatic charge from your body.
3	Insert slotted screwdriver and rotate as shown in the following figure:   This opens the fan cover locking mechanisms.
4	Rotate upward the fan cover out:  
5	Replace the dust filter on the fan filter cover.

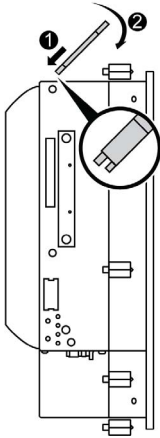
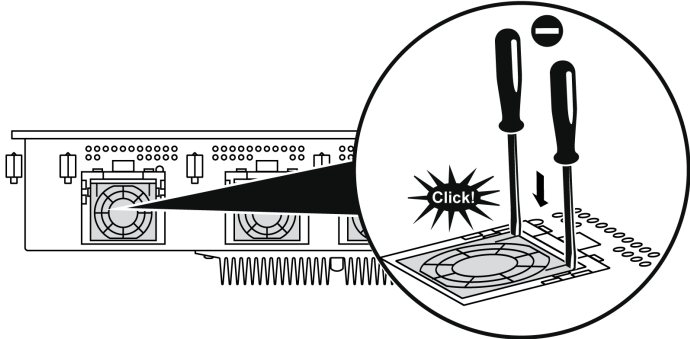
Step	Action
6	<p data-bbox="495 200 1034 227">Place the fan cover on the Industrial Personal Computer:</p>  <ol style="list-style-type: none"> <li data-bbox="495 701 828 728">1 Place the guides for assembly.</li> <li data-bbox="495 728 810 755">2 Rotate the fan cover forward.</li> </ol>
7	<p data-bbox="495 767 1218 819">Secure the fan cover by using slotted screwdrivers to push down the locking mechanism until it clicks:</p> 

## Appendices



# IV

---

### What's in this Part?

This part contains the following chapters:

Chapter	Chapter Name	Page
11	Accessories	161
12	After-sales service	163





## Accessories

# 11

### Accessories for the Industrial Personal Computer

#### Available Accessories

Accessories are available as options. The list of accessories available for the Industrial Personal Computer is shown below:

Description	Reference
CF Card, 4GB	PFXZCBCF41
CF Card, 8GB (only for Core 2 Duo Pre-installed Model)	PFXZCBCF81
HDD Unit without OS, 250GB (for Slide in Disk)	PFXZPSSCHDD251
HDD Unit without OS, 500GB (for Slide in Disk)	PFXZPSSCHDD501
SSD Unit without OS, 32GB (for Slide in Disk)	PFXZPSSCSSD321
SSD Unit without OS, 60GB (for Slide in Disk)	PFXZPSSCSSD601
Adaptor to install an unit (for Slide in Disk to Slide in Slot)	PFXZPSSSAD1
DVD multi drive (for Slide in Slot)	PFXZPSSSMD1
Disposable, dirt-resistant sheet for the 15-inch screen. (5 sheets/set)	CA3-DFS15-01
Disposable, dirt-resistant sheet for the 19-inch screen. (5 sheets/set)	CA3-DFS19-01
Noise Filter for Marine Certification <sup>*1</sup>	PFXZFTPND1
UPS battery unit	PFXZPSEUUPB1
UPS conneciton cable between UPS interface board and UPS battery unit(3m)	PFXZPSCBUP3
Maintenance Items	
Installation fasteners used to install PS4000 Series Panel Type into a solid panel. (18 pcs)	PFXZPPAF18P1
DC power supply connector (Screw type 5 pcs)	PFXZPSCNDC1
AC power supply connector (Screw type 5 pcs)	PFXZPSCNAC1
Lithium battery for replacement (for BIOS backup)	PFXZPSBTLT1
Replacement FAN filter for PS4000 series Panel type with 0/1 Slot (15 pcs=5 sets)	PFXZPP0FTFAN1
Replacement FAN filter for PS4000 series Panel type with 2 Slots (15 pcs=5 sets)	PFXZPP2FTFAN1
Front USB cover for PS4000 series Panel type (2 pcs)	PFXZPPCVUS1
Front USB cover for PS4000 series Panel type (with hook) (2 pcs)	PFXZPPCVUS2
Replacement FAN kit for PS4000 series Panel type with 0/1 Slot (3 pcs=1 set)	PFXZPP0IUFAN1

Description	Reference
Replacement FAN kit for PS4000 series Panel type with 2 Slots (3 pcs=1 set)	PFXZPP2IUFAN1
Installation Fastner to be used to install PS4000 series Panel type (Stainless Steel Bezel) into a solid panel (14 pcs)	PFXZPTAF14P1
Installation Gasket for Stainless Steel Bezel Model which provides dust and moisture resistance, when PS4000 series Panel type is installed into a solid panel (1 piece)	PFXZPTWG151

\*1 The HDD-less DC powered type of the fan-less (Atom N270 embedded), 0-slot models (except for Stainless Steel Bezel Model) is GL certified only when connected to a Noise Filter for Marine Certification.

## **After-sales service**

**12**

---

For details on after-sales service, refer to Pro-face website at  
<http://www.pro-face.com/trans/en/manual/1001.html>

