

PS-4000B Series User Manual



The information provided in this documentation contains general descriptions and/or technical characteristics of the performance of the products contained herein. This documentation is not intended as a substitute for and is not to be used for determining suitability or reliability of these products for specific user applications. It is the duty of any such user or integrator to perform the appropriate and complete risk analysis, evaluation and testing of the products with respect to the relevant specific application or use thereof. Neither Pro-face nor any of its affiliates or subsidiaries shall be responsible or liable for misuse of the information contained herein. If you have any suggestions for improvements or amendments or have found errors in this publication, please notify us.

No part of this document may be reproduced in any form or by any means, electronic or mechanical, including photocopying, without express written permission of Pro-face.

All pertinent state, regional, and local safety regulations must be observed when installing and using this product. For reasons of safety and to help ensure compliance with documented system data, only the manufacturer should perform repairs to components.

When devices are used for applications with technical safety requirements, the relevant instructions must be followed.

Failure to use Pro-face software or approved software with our hardware products may result in injury, harm, or improper operating results.

Failure to observe this information can result in injury or equipment damage.

Copyright © 2014.9 Digital Electronics Corporation. All Rights Reserved.

Table of Contents

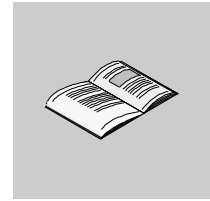

	Safety Information	5
	About the Book	7
Part I	General Overview	13
Chapter 1	Important Information	15
	Federal Communications Commission Radio Frequency Interference Statement - For U.S.A.	16
	Qualified Personnel	17
	Certifications and Standards	18
	European (CE) Compliance	20
	Hazardous Location Installations - For USA and Canada	21
Chapter 2	Physical Overview	25
	Package Contents	26
	PS-B Unit Description	27
	Interface Specifications	34
Chapter 3	Characteristics	41
	Characteristics of PS-B unit	42
	Environmental Characteristics	46
Chapter 4	Dimensions/Assembly	47
	Dimensions	48
	PS-B Unit Mounting	53
	Preparing to Install the PS-B Unit	58
Part II	Implementation	59
Chapter 5	Getting Started	61
	First Power-up	61
Chapter 6	Main Power Connection	63
	Grounding	64
	Connecting the DC Power Cord	68
	USB Outlet on the PS-B Unit	71
Chapter 7	Configuration of the BIOS	75
	BIOS Options	76
	USB Configuration	81
	Boot Menu	83
	Security	85
	Exit	88
Chapter 8	Hardware Modifications	89
	Before Modifications	90
	Uninterruptible Power Supply (UPS)	92
	PCI / PCIe Card Installation	99
	Compact Flash (CF) Card Installation and Removal	105

	Fan Kit Installation	107
Part III	Installation	111
Chapter 9	System Monitor	113
	System Monitor Interface	114
	System Monitor Setting	120
Chapter 10	Maintenance	123
	Reinstallation Procedure	124
	Regular Cleaning and Maintenance	125
Part IV	Appendices	133
Chapter 11	Accessories	135
	Accessories for the PS-B unit	135
Chapter 12	After-sales service	137

Safety Information

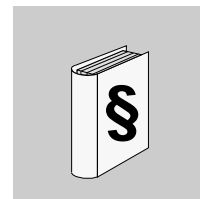

Important Information

NOTICE

Read these instructions carefully, and look at the equipment to become familiar with the device before trying to install, operate, or maintain it. The following special messages may appear throughout this documentation or on the equipment to warn of potential hazards or to call attention to information that clarifies or simplifies a procedure.



The addition of this symbol to a “Danger” or “Warning” safety label indicates that an electrical hazard exists which will result in personal injury if the instructions are not followed.



This is the safety alert symbol. It is used to alert you to potential personal injury hazards. Obey all safety messages that follow this symbol to avoid possible injury or death.

DANGER

DANGER indicates a hazardous situation which, if not avoided, **will result in** death or serious injury.

WARNING

WARNING indicates a hazardous situation which, if not avoided, **could result in** death or serious injury.

CAUTION

CAUTION indicates a hazardous situation which, if not avoided, **could result in** minor or moderate injury.

NOTICE

NOTICE is used to address practices not related to physical injury.

PLEASE NOTE

Electrical equipment should be installed, operated, serviced, and maintained only by qualified personnel. No responsibility is assumed by Pro-face for any consequences arising out of the use of this material.

A qualified person is one who has skills and knowledge related to the construction and operation of electrical equipment and its installation, and has received safety training to recognize and avoid the hazards involved.

About the Book

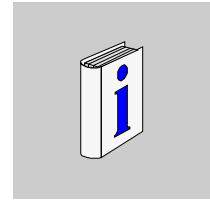

At a Glance

Thank you for purchasing Pro-face's PS-4000B Series (Hereafter referred to as the "PS-B unit").

Document Scope

	PFXP	B	1	B	2	B	D	2	3	C	1	1	0	0	0
Reference	1-4	5	6	7	8	9	10	11	12	13	14	15	16	17	18

Reference	Character Description	Possible Values
1-4	Part Number	PFXP
5	Base Unit	B: Built-in Computer
6	Reserved	-
7	Display	B: None(Built-in Computer)
8	Expansion slots	1: 1 slot = 1 PCI 2: 2 slots = 1 PCI+1 PCIe A: 2 slots = 2 PCI 5: 5 slots = 2 PCI+3 PCIe B: 5 slots = 4 PCI+1 PCIe
9	CPU type	B: Atom N270 C: Core 2 Duo P8400
10	Power Supply	B : DC with I/F for UPS battery unit D: DC F: DC with Noise filter for Marine Certification G: DC with I/F for UPS battery unit and Noise Filter for Marine Certification
11	RAM (Configuration available depend on CPU)	1: 1 GB 2: 2 GB 3: 3 GB = 1 GB + 2 GB 4: 4 GB = 2 GB + 2 GB 6: 6 GB = 2 GB + 4 GB 8: 8 GB = 4 GB + 4 GB
12	Operating System	0: None 1: Windows Embedded Standard 2009 MUI 2: Windows XP Pro Japanese 3: Windows XP Pro MUI 4: Windows Embedded Standard 7 MUI (32bit) 5: Windows 7 Ultimate MUI (32bit) 6: Windows 7 Ultimate MUI (64bit)

Reference	Character Description	Possible Values
13	Storage Device (where to install the OS)	N: None C: CF Card 4GB D: CF Card 8GB K: HDD T: SSD
14	Slide-in Slot	0: None 1: DVD Multi drive 2: HDD 3: SSD 4: DVD Multi drive + HDD 5: DVD Multi drive + SSD
15	Built-in Options	0: None 2: DVI-D I/F Expansion Board 4: COM Expansion Board RS-232C/422/485 5: DVI-D I/F Expansion Board + COM Expansion Board RS-232C/422/485
16	Software bundle	N: None
17, 18	Reserved	-

Validity Note

This documentation is valid for PS-4000B.

The technical characteristics of the device(s) described in this manual appear online. To access this information online, please go to our site <http://www.pro-face.com/otasuke/>

The characteristics presented in this manual should be constantly improved for clarity and accuracy. In the event that you see a difference between the manual in your PC and online information, use the online information as your reference.

Registered Trademarks

The company names and product names used in this manual are the trade names, trademarks (including registered trademarks), and service marks of their respective companies. This product omits individual descriptions of each of these rights.

Trademark / Tradename	Right Holder
Microsoft, Windows	Microsoft, U.S.
Pro-face	Digital Electronics Corporation (in Japan and other countries)
Intel	Intel Corporation
Adobe	Adobe Systems Incorporated

The following terms differ from the abovementioned trade names and trademarks.

Term used in this manual	Formal Trademark or Tradename
Windows Embedded Standard 2009	Microsoft® Windows® Embedded Standard Runtime
Windows Embedded Standard 7	Windows® Embedded Standard 7 Runtime (WS7P)(ESD)
Windows XP Pro	Microsoft® Windows® XP Professional for Embedded Systems (1-2 CPU) ESD
Windows 7	Windows® 7 Ultimate for Embedded Systems x32 (1-2 CPU) (ESD)
Adobe Reader	Adobe® Reader®
Atom N270	Intel® Atom™ N270
Core 2 Duo	Intel® Core™ 2 Duo P8400

Related Documents

Title of Documentation
PS-4000B Series User Manual (this manual)

You can download these technical publications and other technical information from our website "Otasuke Pro!" at <http://www.pro-face.com/otasuke/>.

Global Code

A global code is assigned to every Pro-face product as a universal reference. For more information on product models and their matching global codes, please refer to the following URL.

<http://www.pro-face.com/product/globalcode.html>

Product Related Information

PS-B units are certified for use in Class I, Division 2 hazardous locations as defined in ANSI/ISA 12.12.01 or CSA C22.2 N°213. Observe the following:

DANGER

HAZARD OF ELECTRIC SHOCK, EXPLOSION OR ARC FLASH

- Remove all power from the device before removing any covers or elements of the system, and prior to installing or removing any accessories, hardware, or cables.
- Unplug the power cable from both the PS-B unit and the power supply.
- Always use a properly rated voltage sensing device to confirm power is off.
- Replace and secure all covers or elements of the system before applying power to the unit.
- Use only 24 Vdc when operating the PS-B unit.

Failure to follow these instructions will result in death or serious injury.

WARNING

LOSS OF CONTROL

- The designer of any control scheme must consider the potential failure modes of control paths and, for certain critical control functions, provide a means to achieve a safe state during and after a path failure. Examples of critical control functions are emergency stop and overtravel stop.
- Separate or redundant control paths must be provided for critical control functions.
- System control paths may include communication links. Consideration must be given to the implications of unanticipated transmission delays or failures of the link.*1
- Each implementation of a PS-B unit must be individually and thoroughly tested for proper operation before being placed into service.

Failure to follow these instructions can result in death, serious injury, or equipment damage.

*1For additional information, refer to *NEMA ICS 1.1 (latest edition), "Safety Guidelines for the Application, Installation, and Maintenance of Solid State Control"* and to *NEMA ICS 7.1 (latest edition), "Safety Standards for Construction and Guide for Selection, Installation and Operation of Adjustable-Speed Drive Systems"* or other applicable standards in your location.

NOTE: PS-B is a highly configurable device and is not based on a real-time operating system. Changes to the software and settings of the following must be considered new implementations as discussed in the previous warning messages. Examples of such changes include:

- System BIOS
- System Monitor
- Operating system
- Installed hardware
- Installed software

 WARNING

UNINTENDED EQUIPMENT OPERATION

Use only the software provided with this product. If you use the other software, please confirm the operation and safety before you use.

Failure to follow these instructions can result in death, serious injury, or equipment damage.

General Overview

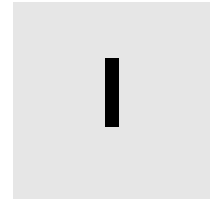

Subject of this Part

This part provides an overview of PS-B unit.

What's in this Part?

This part contains the following chapters:

Chapter	Chapter Name	Page
1	Important Information	15
2	Physical Overview	25
3	Characteristics	41
4	Dimensions/Assembly	47

Important Information



General

This chapter describes the safety aspects which are specific to the operation of the PS-B unit.

What's in this Chapter?

This chapter contains the following topics:

Topic	Page
Federal Communications Commission Radio Frequency Interference Statement - For U.S.A.	16
Qualified Personnel	17
Certifications and Standards	18
European (CE) Compliance	20
Hazardous Location Installations - For USA and Canada	21

Federal Communications Commission Radio Frequency Interference Statement - For U.S.A.

FCC Radio Interference Information

This equipment has been tested and found to comply with the Federal Communications Commission (FCC) limits for a Class A digital device, pursuant to Part 15 of the FCC Rules. These limits are designed to provide reasonable protection against harmful interference in a residential installation. This equipment generates, uses, and can radiate radio frequency energy and, if not installed and used in accordance with the instructions, may cause or be subject to interference with radio communications. To minimize the possibility of electromagnetic interference in your application, observe the following two rules:

- Install and operate the PS-B unit in such a manner that it does not radiate sufficient electromagnetic energy to cause interference in nearby devices.
- Install and test the PS-B unit to ensure that the electromagnetic energy generated by nearby devices does not interfere with the PS-B unit's operation.

WARNING

ELECTROMAGNETIC / RADIO INTERFERENCE

Electromagnetic radiation may disrupt the PS-B unit's operations, leading to unintended equipment operation. If electromagnetic interference is detected:

- Increase the distance between the PS-B unit and the interfering equipment.
- Reorient the PS-B unit and the interfering equipment.
- Reroute power and communication lines to the PS-B unit and the interfering equipment.
- Connect the PS-B unit and the interfering equipment to different power supplies.
- Always use shielded cables when connecting the PS-B unit to a peripheral device or another computer.

Failure to follow these instructions can result in death, serious injury, or equipment damage.

Qualified Personnel

General

Only qualified personnel can install, operate, and maintain the product. A qualified person is one who has skills and knowledge related to the construction, operation, and installation of electrical equipment, and has received safety training to recognize and avoid the hazards involved. Refer to the most current release of NFPA 70E®, Standard for Electrical Safety in the Workplace, for electrical safety training requirements or other applicable standards in your location. Examples of qualified personnel may include:

- at the application design level, engineering department personnel who are familiar with automation safety concepts (for example, a design engineer)
- at the equipment implementation level, personnel who are familiar with the installation, connection and commissioning of automation equipment (for example, an installation assembly or cabling engineer or a commissioning technician)
- at the operation level, personnel who are experienced in the use and control of automation and computing equipment (for example, an operator)
- for preventive or corrective maintenance, personnel trained and qualified in regulating or repairing automated and computing devices (for example, an operating technician or after-sales service technician.)

Certifications and Standards

Agency Certifications

Pro-face submitted this product for independent testing and qualification by third-party agencies. These agencies have certified this product as meeting the following standards.

- Underwriters Laboratories Inc., UL 508 and CSA C22.2 N°142, Industrial Control Equipment
- Underwriters Laboratories Inc., ANSI/ISA 12.12.01 and CSA C22.2 N°213, Electrical Equipment for Use in Class I, Division 2 Hazardous (Classified) Locations
- GOST certified
- ATEX Category 3 Zone 22 certification
- Germanischer Lloyd(GL) Type approval

For information on certifications and standards, such as certified models and certificates, see the following or product markings.

<http://www.pro-face.com/worldwide.html>

Compliance Standards

Pro-face tested this product for compliance with the following compulsory standards.

United States:

- Federal Communications Commission, FCC Part 15

Europe: CE

- Directive 2006/95/EC (Low Voltage)
- Directive 2004/108/EC (EMC)
- Programmable Controllers: EN 61131-2 (Ed 3)
- EMI: EN55011 (Group 1, Class A), EN 61000-6-4
- EMS: EN 61000-6-2
- Directive 94/9/EC (ATEX)

Australia:

- Standard AS/NZS CISPR11 (C-Tick)

Qualification Standards

Pro-face voluntarily tested this product to additional standards. The additional tests performed, and the standards under which the tests were conducted, are specifically identified in Environmental Characteristics (*see page 46*).

Hazardous Substances

This product is compliant with:

- WEEE, Directive 2002/96/EC
- RoHS, Directive 2002/95/EC
- RoHS China, Standard SJ/T 11363-2006

End of Life (WEEE)

The product contains electronic boards. It must be disposed of in specific treatment channels. The product contains cells and/or storage batteries which must be collected and processed separately, when they have run out and on product end of life.

See the Regular Cleaning and Maintenance (*see page 125*) to extract easily and safely extract cells and batteries from the product. These batteries do not contain a weight percentage of heavy metals over the threshold notified by European Directive 2006/66/EC.

KC Marking

사용자안내문

기종별	사용자안내문
A급 기기 (업무용 방송통신기자재)	이 기기는 업무용(A급) 전자파적합기기로서 판매자 또는 사용자는 이 점을 주의하시기 바라며, 가정외의 지역에서 사용하는 것을 목적으로 합니다.

European (CE) Compliance

CE Compliance Note

The products described in this manual comply with the European Directives concerning Electromagnetic Compatibility and Low Voltage (CE marking) when used as specified in the relevant documentation, in applications for which they are specifically intended, and in connection with approved third-party products.

Hazardous Location Installations - For USA and Canada

General

The PS-B unit has been designed with the intention of meeting the requirements of Class I, Division 2 hazardous location applications. Division 2 locations are those locations where ignitable concentrations of flammable substances are normally confined, prevented by ventilation, or present in an adjacent Class I, Division 1 location, but where an abnormal situation might result in intermittent exposure to such ignitable concentrations.

While the PS-B unit is a non-incendive device under ANSI/ISA 12.12.01 and CSA C22.2 N°213, it is not designed for, and should never be used within a Division 1 (normally hazardous) location.

PS-B units are suitable for use in Class I, Division 2, Groups A, B, C, and D hazardous locations or in non-hazardous locations. Before installing or using your PS-B unit, confirm that the ANSI/ISA 12.12.01 or CSA C22.2 N°213 certification appears on the product labeling

NOTE: Some PS-B units are not yet rated as suitable for use in hazardous locations. Always use your product in conformance with the product labeling and this manual.

DANGER

EXPLOSION HAZARD

- Do not use your PS-B unit in hazardous environments or locations other than Class I, Division 2, Groups A, B, C, and D.
- Always confirm that your PS-B unit is suitable for use in hazardous locations by checking that the ANSI/ISA 12.12.01 or CSA C22.2 N°213 certification appears on the product labeling.
- Do not install any Pro-face or OEM components, equipment, or accessories unless these have also been qualified as suitable for use in Class I, Division 2, Groups A, B, C, and D locations.
- In addition, confirm that any PCI/PCle controller cards have a temperature code (T-code), and are suitable for an ambient temperature range of +0°C to +50°C (32°F to 122°F).
- Do not attempt to install, operate, modify, maintain, service, or otherwise alter the PS-B unit except as permitted in this manual. Unpermitted actions may impair the unit's suitability for Class I, Division 2 operation.

Failure to follow these instructions will result in death or serious injury.

⚠ DANGER**EXPLOSION HAZARD**

- Always confirm the ANSI/ISA 12.12.01 and CSA C22.2 N°213 hazardous location rating of your device before installing or using it in a hazardous location.
- To power on or power off a PS-B unit installed in a Class I, Division 2 hazardous location, you must either:
 - Use a switch located outside the hazardous environment, or
 - Use a switch certified for Class I, Division 1 operation inside the hazardous area.
- Do not disconnect equipment unless power has been switched off or the area is known to be non-hazardous. This applies to all connections including power, ground, serial, parallel, and network connections.
- Never use unshielded / ungrounded cables in hazardous locations.
- Use only non-incendive USB configuration.
- When enclosed, keep enclosure doors and openings closed at all times to avoid the accumulation of foreign matter inside the workstation.

Failure to follow these instructions will result in death or serious injury.

⚡ ⚠ DANGER**HAZARD OF ELECTRIC SHOCK, EXPLOSION OR ARC FLASH**

- Remove all power from the device before removing any covers or elements of the system, and prior to installing or removing any accessories, hardware, or cables.
- Unplug the power cable from both the PS-B unit and the power supply.
- Always use a properly rated voltage sensing device to confirm power is off.
- Replace and secure all covers or elements of the system before applying power to the unit.
- Use only 24 Vdc when operating the PS-B unit.

Failure to follow these instructions will result in death or serious injury.

Ensure that the product is properly rated for the location. If the intended location does not presently have a Class, Division and Group rating, then users should consult the appropriate authorities having jurisdiction in order to determine the correct rating for that hazardous location.

In accordance with Federal, State/Provincial, and Local regulations, all hazardous location installations should be inspected prior to use by the appropriate authority having jurisdiction. Only technically qualified personnel should install, service, and inspect these systems.

Power Switch

DANGER

HAZARD OF ELECTRIC SHOCK, EXPLOSION OR ARC FLASH

- Remove all power from the device before removing any covers or elements of the system, and prior to installing or removing any accessories, hardware, or cables.
- Unplug the power cable from both the PS-B unit and the power supply.
- Always use a properly rated voltage sensing device to confirm power is off.
- Replace and secure all covers or elements of the system before applying power to the unit.
- Use only 24 Vdc when operating the PS-B unit.

Failure to follow these instructions will result in death or serious injury.

The amount of input power required by systems with a PS-B unit classifies the power switch as an incendive device because the voltage and current across the make/break component are capable of generating a spark.

If using an ordinary power switch, hazardous location regulations require the power switch be located in an area specified as non-hazardous.

However, limits in cable length between the workstation and the power switch may apply. Otherwise the switch must be compliant with Class I, Division 1 requirements (intrinsically safe). These switches are built in a manner that prevents the possibility of a spark when contact is made or broken.

Use suitable UL listed and/or CSA Certified Class I, Division 1 switches in hazardous locations. These switches are available from a wide number of sources. It is the responsibility to ensure you select a power switch that conforms to the hazardous location rating for the installation.

Cable Connections

DANGER

EXPLOSION HAZARD

- Always confirm the ANSI/ISA 12.12.01 and CSA C22.2 N°213 hazardous location rating of your device before installing or using it in a hazardous location.
- To power on or power off a PS-B unit installed in a Class I, Division 2 hazardous location, you must either:
 - Use a switch located outside the hazardous environment, or
 - Use a switch certified for Class I, Division 1 operation inside the hazardous area.
- Do not disconnect equipment unless power has been switched off or the area is known to be non-hazardous. This applies to all connections including power, ground, serial, parallel, and network connections.
- Never use unshielded / ungrounded cables in hazardous locations.
- Use only non-incendive USB configuration.
- When enclosed, keep enclosure doors and openings closed at all times to avoid the accumulation of foreign matter inside the workstation.

Failure to follow these instructions will result in death or serious injury.

Division 2 hazardous location regulations require that all cable connections be provided with adequate strain relief and positive interlock. Use only non-incendive USB devices as USB connections do not provide adequate strain relief to allow the use of the PS-B unit's USB connections (see page 71). Never connect or disconnect a cable while power is applied at either end of the cable. All communication cables should include a chassis ground shield. This shield should include both copper braid and aluminum foil. The D-sub style connector housing must be a metal conductive type (e.g., molded zinc) and the ground shield braid must be terminated directly to the connector housing. Do not use a shield drain wire.

The outer diameter of the cable must be suited to the inner diameter of the cable connector strain relief so that a reliable degree of strain relief is maintained. Always secure the D-Sub connectors to the workstation-mating connectors via the two screws located on both sides.

Operation and Maintenance

The systems have been designed for compliance with relevant spark ignition tests.

 DANGER
EXPLOSION HAZARD
In addition to the other instructions in this manual, observe the following rules when installing the PS-B unit in a hazardous location:
<ul style="list-style-type: none"> • Wire the equipment in accordance with the National Electrical Code article 501.10(B) for Class I, Division 2 hazardous locations.
Failure to follow these instructions will result in death or serious injury.

Hazardous Location Installations - For ATEX

PS-4000B Series must only be mounted in to the category 3D enclosures according to the directive 94/9/EC.

The assembled units with an enclosure should be marked:



II 3D Ex tc IIIA T85°C Dc Tamb: 0°C to +50°C

Marine Installations - For Germanischer Lloyd (GL)

The HDD-less DC powered type of the fan-less (Atom N270 embedded) model is GL certified only when connected to a Noise Filter for Marine Certification.

Physical Overview

2

Subject of this Chapter

This chapter provides a physical overview of the product.

What's in this Chapter?

This chapter contains the following topics:

Topic	Page
Package Contents	26
PS-B Unit Description	27
Interface Specifications	34

Package Contents

Items

The following items are included in the PS-B unit package. Before using the PS-B unit, please confirm that all items listed here are present.

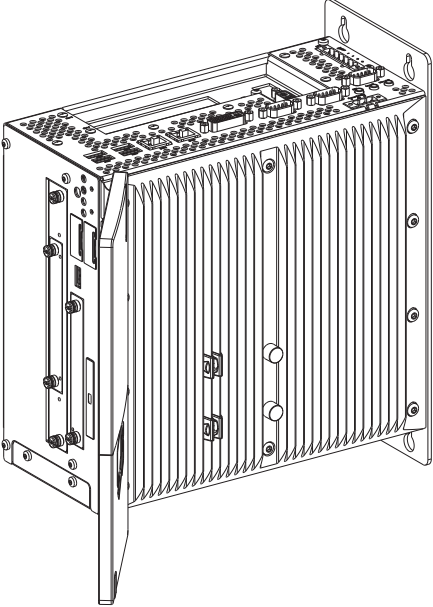
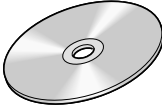
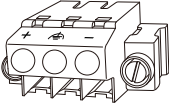
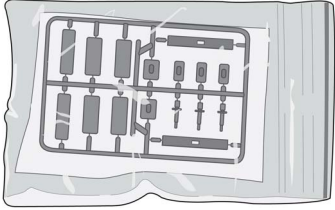
PS-B unit	
DVD-ROM containing the software required to reinstall the Operating System.	
DC power supply connector	
Documents	<ul style="list-style-type: none"> ● Warning/Caution Information ● The MS Windows EULA ● PS4000 Series Installation Guide
Connector cover (2)	

This unit has been carefully packed, with special attention to quality. However, should you find anything damaged or missing, please contact your local PS-B distributor immediately.

PS-B Unit Description

Introduction

During operation, surface temperatures of the heat sink may reach 70°C (158°F).

⚠ WARNING

RISK OF BURNING INJURY

Do not touch the surface of the heat sink during operation.

Failure to follow these instructions can result in death, serious injury, or equipment damage.

PS-B unit 1 slot Unit Description

Interfaces top View

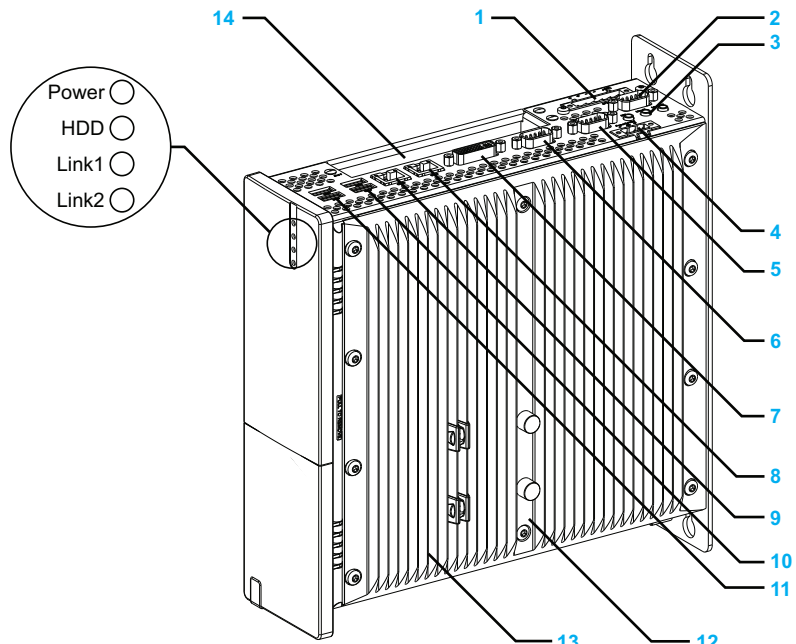

- 1 UPS Interface Board (Built-in option)
- 2 COM Expansion Board (Built-in option)
- 3 MIC, Line IN, Line OUT
- 4 Power Connector (24 Vdc)
- 5 COM2: Serial Interface
- 6 COM1: Serial Interface
- 7 DVI-I Interface
- 8 ETH1: Ethernet Interface (10/100/1000 MBit)
- 9 ETH2: Ethernet Interface (10/100/1000 MBit)
- 10 USB2, USB4 (max 500mA)
- 11 USB1, USB3 (max 1A)
- 12 Warning sign/Heat sink seal
- 13 Heat sink
- 14 Slot 1: PCI slot (half-size)

Interface Front View

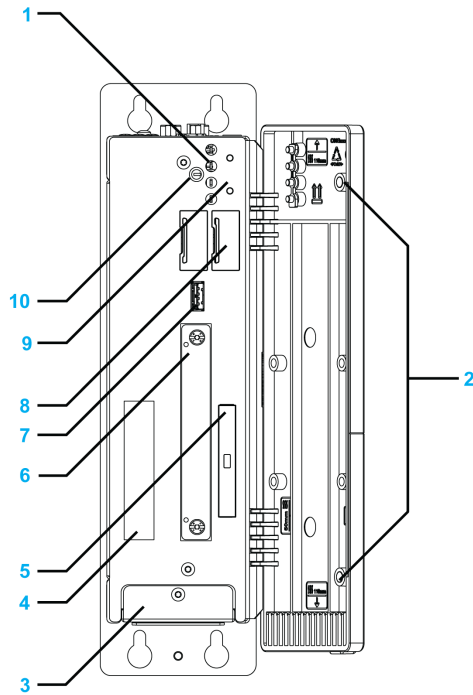

1 Status LEDs

LED	Color		Meaning
Power	Green	On	Supply voltage OK
	Red	On	The system is in standby mode (S5: soft-off mode or S4: hibernate mode -Suspend-to-Disk)
	Orange ^{*1}	On	Supply voltage not OK; the system is operating on battery power.
HDD	Yellow	On	Signals drive access (CF, HDD, CD, etc.)
Link1	-	-	Not used
Link2	-	-	Not used

^{*1}Only lit when UPS battery unit is installed.

- 2 Permanent magnet
- 3 Fan cover
- 4 Serial number sticker
- 5 Compact Flash slot CF1/Connection via IDE-PATA
- 6 Slide in Disk
- 7 Front USB (USB5 max. 1 A)
- 8 Lithium battery for BIOS backup
- 9 Power/Reset button
- 10 CMOS Profile switch (page.88).

NOTE: The front USB is a diagnostic interface for service and maintenance.

NOTICE

UNINTENDED EQUIPMENT OPERATION

- Do not use the front USB (USB5) while the machine is in operation.
- Always keep the blue cover closed during normal operation.

Failure to follow these instructions can result in equipment damage.

PS-B Unit 2 slot Unit Description

Interface Top View

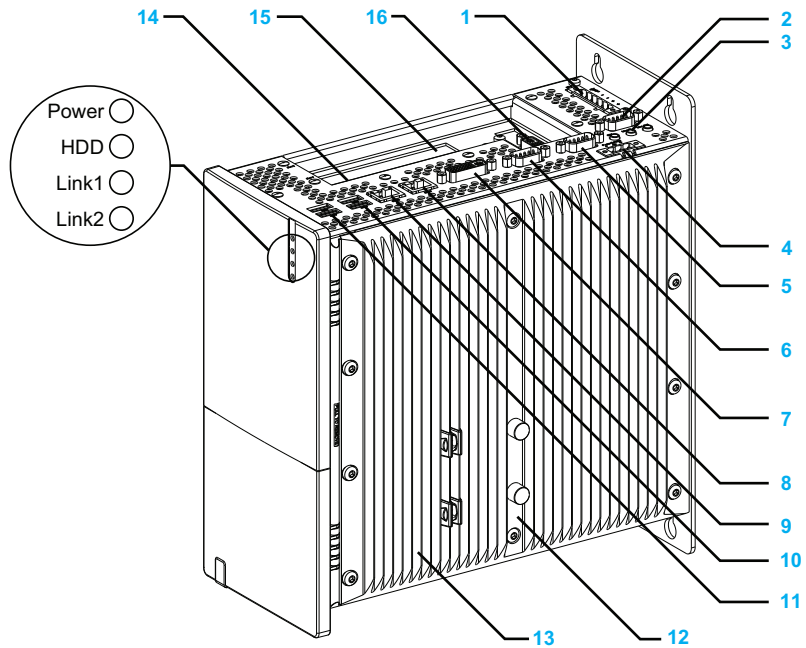

- 1 UPS Interface Board (Built-in option)
- 2 COM Expansion Board (Built-in option)
- 3 MIC, Line IN, Line OUT
- 4 Power Connector (24 Vdc)
- 5 COM2: Serial Interface
- 6 COM1: Serial Interface
- 7 DVI-I Interface
- 8 ETH1: Ethernet Interface (10/100/1000 MBit)
- 9 ETH2: Ethernet Interface (10/100/1000 MBit)
- 10 USB2, USB4 (max.500 mA)
- 11 USB1, USB3 (max.1A)
- 12 Warning sign/Heat sink seal
- 13 Heat sink
- 14 Slot 1: PCI slot (half-size)
- 15 Slot 2: PCIe slot or PCI slot (half-size)
- 16 DVI-D I/F Expansion Board (Built-in option)

Interface Front View

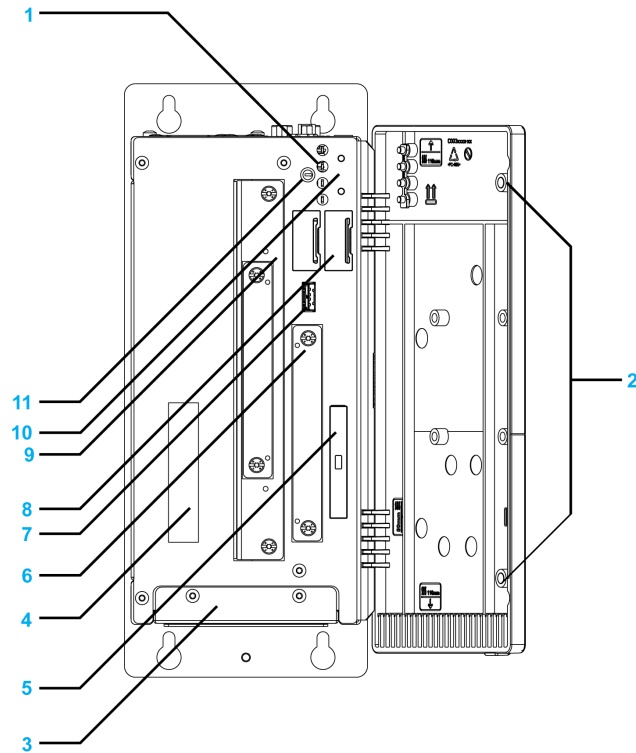

1 Status LEDs

LED	Color		Meaning
Power	Green	On	Supply voltage OK
	Red	On	The system is in standby mode (S5: soft-off mode or S4: hibernate mode -Suspend-to-Disk)
	Orange* ¹	On	Supply voltage not OK; the system is operating on battery power.
HDD	Yellow	On	Signals drive access (CF, HDD, CD, etc.)
Link1	-	-	Not used
Link2	-	-	Not used

*¹Only lit when UPS battery unit is installed.

- 2 Permanent magnet
- 3 Fan cover
- 4 Serial number sticker
- 5 Compact Flash slot CF1/Connection via IDE-PATA
- 6 Slide in Disk (Connection via SATA)
- 7 Front USB (USB5 max. 1 A)
- 8 Lithium battery for BIOS backup
- 9 Slide in Slot 1 (connection via SATA)
- 10 Power/Reset button
- 11 CMOS Profile switch (page.88)

NOTE: The front USB is a diagnostic interface for service and maintenance.

NOTICE

UNINTENDED EQUIPMENT OPERATION

- Do not use the front USB (USB5) while the machine is in operation.
- Always keep the blue cover closed during normal operation.

Failure to follow these instructions can result in equipment damage.

PS-B Unit 5 slot Unit Description

Interface Top View

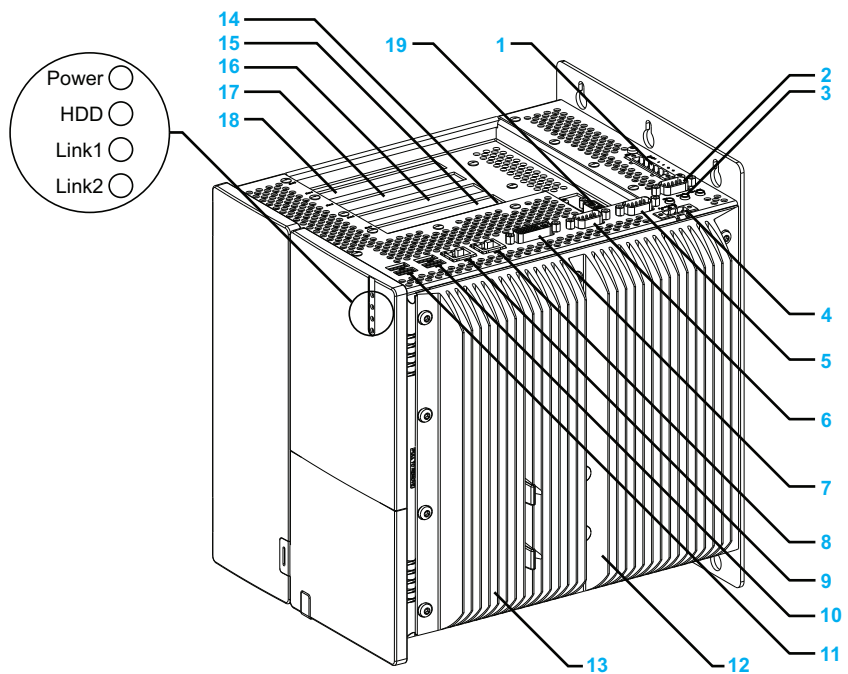

- 1 UPS Interface Board (Built-in option)
- 2 COM Expansion Board (Built-in option)
- 3 MIC, Line IN, Line OUT
- 4 Power Connector (24 Vdc)
- 5 COM2: Serial Interface
- 6 COM1: Serial Interface
- 7 DVI-I Interface
- 8 ETH1: Ethernet Interface (10/100/1000 MBit)
- 9 ETH2: Ethernet Interface (10/100/1000 MBit)
- 10 USB2, USB4 (max. 500 mA)
- 11 USB1, USB3 (max. 1 A)
- 12 Warning sign/Heat sink seal
- 13 Heat sink
- 14 Slot 1: PCI slot (half-size)
- 15 Slot 2: PCI slot (half-size)
- 16 Slot 3: PCIe slot or PCI slot (half-size)
- 17 Slot 4: PCIe slot or PCI slot (half-size)

- 18 Slot 5: PCIe slot (half-size)
- 19 DVI-D I/F Expansion Board (Built-in option)

Interface Front View

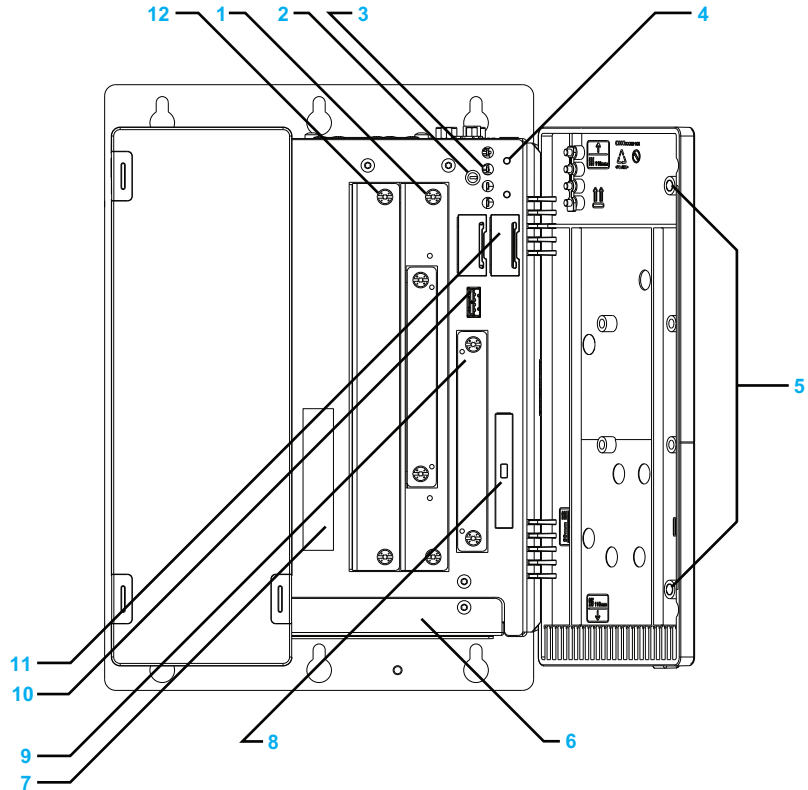

- 1 Slide in Slot 1 (Connection via SATA)
- 2 CMOS profile switch
- 3 Status LEDs

LED	Color		Meaning
Power	Green	On	Supply voltage OK
	Red	On	The system is in standby mode (S5: soft-off mode or S4: hibernate mode -Suspend-to-Disk)
	Orange* ¹	On	Supply voltage not OK; the system is operating on battery power.
HDD	Yellow	On	Signals drive access (CF, HDD, CD, etc.)
Link1	-	-	Not used
Link2	-	-	Not used

*¹Only lit when UPS battery unit is installed.

- 4 Power/Reset button
- 5 Permanent magnet
- 6 Fan cover
- 7 Serial number sticker
- 8 Compact Flash slot CF1/Connection via IDE - PATA
- 9 Slide in Disk (Connection via SATA)
- 10 Front USB (USB5 max. 1 A)
- 11 Lithium battery for BIOS backup

12 Slide in Slot 2 (Connection via SATA)

NOTE: The front USB is a diagnostic interface for service and maintenance.

NOTICE

UNINTENDED EQUIPMENT OPERATION

- Do not use the front USB (USB5) while the machine is in operation.
- Always keep the blue cover closed during normal operation.

Failure to follow these instructions can result in equipment damage.

Interface Specifications

Communication Connections

DANGER

EXPLOSION HAZARD

- Always confirm the ANSI/ISA 12.12.01 and CSA C22.2 N°213 hazardous location rating of your device before installing or using it in a hazardous location.
- To power on or power off a PS-B unit installed in a Class I, Division 2 hazardous location, you must either:
 - Use a switch located outside the hazardous environment, or
 - Use a switch certified for Class I, Division 1 operation inside the hazardous area.
- Do not disconnect equipment unless power has been switched off or the area is known to be non-hazardous. This applies to all connections including power, ground, serial, parallel, and network connections.
- Never use unshielded / ungrounded cables in hazardous locations.
- Use only non-incendive USB configuration.
- When enclosed, keep enclosure doors and openings closed at all times to avoid the accumulation of foreign matter inside the workstation.

Failure to follow these instructions will result in death or serious injury.

WARNING

EQUIPMENT DISCONNECTION OR UNINTENDED EQUIPMENT OPERATION

- Ensure that power, communication, and accessory connections do not place excessive stress on the ports. Consider the vibration environment when making this determination.
- Securely attach power, communication, and external accessory cables to the panel or cabinet.
- Use only commercially available USB cables.
- Use the Single-link Monitor to connect DVI-D I/F Expansion Board. If you use the Dual-link Monitor, the monitor is unable to show and it will cause malfunction to the monitor.

Failure to follow these instructions can result in death, serious injury, or equipment damage.

Serial Interfaces

COM 1 and COM 2: These interfaces are used to connect an RS-232C (serial) cable with a D-Sub 9 pin connector.

Serial interface COM1 and COM2	
Connector	D-Sub 9 pin plug
Type	RS-232C, modem-capable, not electrically isolated
UART	16650-compatible, 16-byte FIFO
Transfer rate	Max. 115 kBit/s
Cable length	Max. 15 meters (49.21 feet)
Interfit Bracket	#4-40 (UNC)
Pin	Assignment
1	DCD
2	RXD
3	TXD
4	DTR
5	GND
6	DSR
7	RTS
8	CTS
9	RI

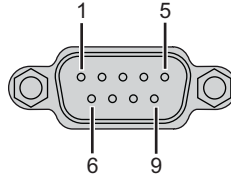

COM Expansion Board (Built-in option)

COM Expansion Board Pin Assignments: This interface is a Built-in option. It is a combined RS-232C/RS-422/RS-485 interface with D-SUB 9 pin connector. The operating mode (RS-232C/RS-422/RS-485) is selected automatically, depending on the electrical connection.

The RS-232C pin assignments are different between the serial interface and the COM Expansion Board.

Do not connect anything to pins 1, 4, 6, and 9 when using RS-232C with the COM Expansion Board.

⚠ CAUTION

UNINTENDED PIN WIRING

- Do not connect anything to n.c. pins.

Failure to follow these instructions can result in injury or equipment damage.

COM Expansion Board Pin Assignments

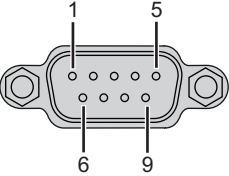
Connector	D-Sub 9 pin plug		
Type	RS-232C not modem compatible; Electrically isolated		
UART	16550 compatible, 16 byte FIFO		
Transfer rate	Max. 115 kBit/s		
Cable length	Max. 15 meters (49.21 feet)	Max. 1200 meters (3937.01 feet)	
Pin	Assignments (RS-232C)	Assignments (RS-422)	
1	n.c.	TXD\	
2	RXD	n.c.	
3	TXD	n.c.	
4	n.c.	TXD	
5	GND	GND	
6	n.c.	RXD\	
7	RTS	n.c.	
8	CTS	n.c.	
9	n.c.	RXD	

RS-232C - Bus length and cable type

The maximum transfer rate of 115 kBit/s depends on the cable type being used.

Distance [m]	Transfer rate [kBit/s]
≤ 15	Typ. 64
≤ 10	Typ. 115
≤ 5	Typ. 115

The material used for the cable should preferably have all or most of the following properties in order to reach an optimal transfer rate.

RS-232C cable	Property
Signal lines	
Cable cross section	4 x 0.16 mm ² (26AWG), tinned Cu wire
Wire insulation	PE
Conductor resistance	≤ 82 Ω/km
Stranding	Wires stranded in pairs
Shield	Paired shield with aluminum foil
Grounding line	
Cable cross section	1 x 0.34 mm ² (22AWG/19), tinned Cu wire
Wire insulation	PE
Conductor resistance	≤ 59 Ω/km
Outer sheathing	
Material	PUR mixture
Characteristics	Halogen free
Entire shielding	From tinned cu wires

RS-422 - Bus length and cable type

The RTS line must be switched on to activate the sender.

The maximum transfer rate of 115 kBit/s depends on the cable type being used.

Distance [m]	Transfer rate [kBit/s]
1200	Typ. 115

The material used for the cable should preferably have all or most of the following properties in order to reach an optimal transfer rate.

RS-422 cable	Property
Signal lines Cable cross section Wire insulation Conductor resistance Stranding Shield	4 x 0.25 mm ² (24AWG/19), tinned Cu wire PE ≤ 82 Ω/km Wires stranded in pairs Paired shield with aluminum foil
Grounding line Cable cross section Wire insulation Conductor resistance	1 x 0.34 mm ² (22AWG/19), tinned Cu wire PE ≤ 59 Ω/km
Outer sheathing Material Characteristics Entire shielding	PUR mixture Halogen free From tinned cu wires

RS-485 interface operation

The pins of the RS-422 default interface (1, 4, 6 and 9) should be used for operation. The pins should be connected as shown.

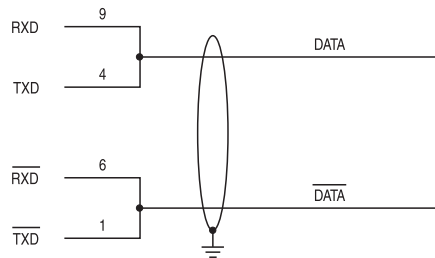

The RTS line must be switched each time the driver is sent and received; there is no automatic switch back. This cannot be configured in Windows.

The voltage drop caused by long line lengths can lead to greater potential differences between the bus stations, which can hinder communication. This can be improved by running ground wire with the others.

The line ends of the RS-485 interface should (at least for longer line lengths or larger transfer rates) be closed. Normally a passive terminator can be used on the bus ends by connecting each of the signal lines with 120 Ω resistance.

RS-485 - Bus length and cable type

The maximum transfer rate of 115 kBit/s depends on the cable type being used.

Distance [m]	Transfer rate [kBit/s]
1200	Typ. 115

The material used for the cable should preferably have all or most of the following properties in order to reach an optimal transfer rate.

RS-485 cable	Property
Signal lines	
Cable cross section	4 x 0.25 mm ² (24AWG/19), tinned Cu wire
Wire insulation	PE
Conductor resistance	≤ 82 Ω/km
Stranding	Wires stranded in pairs
Shield	Paired shield with aluminum foil
Grounding line	
Cable cross section	1 x 0.34 mm ² (22AWG/19), tinned Cu wire
Wire insulation	PE
Conductor resistance	≤ 59 Ω/km
Outer sheathing	
Material	PUR mixture
Characteristics	Halogen free
Entire shielding	From tinned cu wires

DVI-D I/F Expansion Board(Built-in option)

This interface is a Built-in option.

Please note that the DVI-D I/F Expansion Board and the embedded DVI-I Interface are different.

⚠ WARNING

EQUIPMENT DISCONNECTION OR UNINTENDED EQUIPMENT OPERATION

- Use the Single-link Monitor to connect DVI-D I/F Expansion Board. If you use the Dual-link Monitor, the monitor is unable to show and it will cause malfunction to the monitor.
- Do not connect anything to pins for n.c. and System Reserve.

Failure to follow these instructions can result in death, serious injury, or equipment damage.

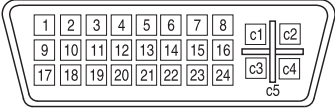
DVI-D I/F Expansion Board			
Type	DVI-I 24 pin, Socket		
Recommended Screw Type	No.4(40 UNC)		
Cable length	Max. 5 meters (16.40 feet)		
Pin	Assignment	Pin	Assignment
1	T.M.D.S. data 2-	16	Hot Plug detect
2	T.M.D.S. data 2+	17	T.M.D.S. data 0-
3	T.M.D.S. data 2 shield	18	T.M.D.S. data 0+
4	System Reserve	19	T.M.D.S. data 0 shield
5	System Reserve	20	System Reserve
6	DDC clock	21	System Reserve
7	DDC data	22	T.M.D.S. shield
8	n.c.	23	T.M.D.S. clock +
9	T.M.D.S. data 1-	24	T.M.D.S. clock -
10	T.M.D.S. data 1+	c1	n.c.
11	T.M.D.S. data 1 shield	c2	n.c.
12	System Reserve	c3	n.c.
13	System Reserve	c4	n.c.
14	+ 5V power*1	c5	n.c.
15	Ground (return for + 5 V, HSync and VSync)		

*1 Protected internally by a multifuse

Characteristics



3

Subject of this Chapter

This chapter lists the product characteristics.

What's in this Chapter?

This chapter contains the following topics:

Topic	Page
Characteristics of the PS-B unit	42
Environmental Characteristics	46

Characteristics of PS-B unit

Product Characteristics

The characteristics of the PS-B units are given below:

Element	Characteristics				
	AtomN270 1 slot	AtomN270 2 slots	Core2Duo P8400 1 slot	Core2Duo P8400 2 slots	Core2Duo P8400 5 slots
Expansion slots	1 = 1PCI	2 = 1 PCI + 1 PCIe A = 2 PCI	1 = 1 PCI	2 = 1 PCI + 1 PCIe A = 2 PCI	5 = 2 PCI + 3 PCIe B = 4 PCI+ 1 PCIe
Processor	AtomN270 1.6 GHz 512 KB L2 cache		Core2Duo P8400 2.26 GHz 3 MB L2 cache		
Chipset	945GME		GM45		
Cooling method	Passive heat sink, Fanless operation		Fan kit with filter Fan speed is controlled by internal temperature. Fan does not operate unless internal temperature reaches the set temperature.		
RAM	DDR2 533 MHz SO-DIMM 2 slots 1 GB to 3 GB max (Unable to be added by Users.)		DDR3 1066 MHz SO-DIMM 2 slots 2 GB to 8 GB max (Unable to be added by Users.)		
Graphics					
Controller	Intel® Graphics Media Accelerator 950		Intel® Graphics Media Accelerator (GMA) 4500 MHD		
Memory	Up to 224 MB (reserved from main memory)		Up to 384 MB (reserved from main memory)		
Color depth	32 bit (maximum)				
Resolution					
RGB	400 MHz RAMDAC, up to 2048 x 1536 @75 Hz (QXGA) including 1920 x 1080 @85 Hz (HDTV)		300 MHz RAMDAC, up to 2048 x 1536 @70 Hz (QXGA) including 1920 x 1080 @85 Hz (HDTV)		
DVI	1920 x 1080				
Slide in Disk					
Slide in Disk	1 slot equipped ● HDD or SSD				
CompactFlash					
CompactFlash	1 slot type 1 equipped ● CF Card 4 GB, or CF Card 8GB				
Operating System ^{*1}					
Operating System ^{*1}	HDD or SSD: Windows® XP Professional SP3 CF: Windows® Embedded Standard 2009		HDD or SSD: Windows® XP Professional SP3/Windows® 7 Ultimate CF: Windows® Embedded Standard 2009/Windows® Embedded Standard 7 ^{*2}		
Slide in Slot					
Slide in Slot	None	1 slot equipped with: ● DVD-RW ● HDD, SSD and Slide-in Slot Adapter unit also available	None	1 slot equipped with: ● DVD-RW ● HDD, SSD and Slide-in Slot Adapter unit also available	2 slots with 1 equipped with: ● DVD-RW ● DVD-RW+HDD and DVD-RW+SSD also available

Characteristics

Element	Characteristics				
	AtomN270 1 slot	AtomN270 2 slots	Core2Duo P8400 1 slot	Core2Duo P8400 2 slots	Core2Duo P8400 5 slots
Serial Interface ^{*3}					
Amount	3				
Type	RS-232C, modem-capable, not electrically isolated x 1 RS-232C/422/485, RS-232C not modem compatible, electrically isolated x 1 (Built-in option)				
UART	16550-compatible, 16-byte FIFO				
Transfer rate	115 kBit/s				
Connection	9-pin D-Sub				
USB Interface ^{*3}					
Amount	5				
Type	USB 2.0				
Transfer rate	Low speed (1.5 Mbit/s), full speed (12 Mbit/s), to high speed (480 Mbit/s)				
Connection	Type A				
Current load	Max. 500 mA per connection for USB2, USB4 Max 1 A per connection for USB1, USB3, USB5				
Ethernet Interface ^{*3}					
Amount	2				
Speed	10/100/1000 Mbit/s				
Connection	RJ-45 Modular jack				
DVI Interface					
Amount	2				
Type	DVI-I x 1				
	-	DVI-D x 1 (Built-in option)	-	DVI-D x 1 (Built-in option)	DVI-D x 1 (Built-in option)
Reset button	Yes				
Buzzer	Yes				
Power supply	24 Vdc ±25 %				
Rated voltage	6A				
Rated current	Typically 7 A, 50 A < 300 µs				
Inrush current					
UPS	Optional				
Outer dimensions (Width x Height x Depth)	82 x 270 x 250 mm (3.23 x 10.63 x 9.85 in.)	121 x 270 x 251 mm (4.76 x 10.63 x 9.89 in.)	97 x 270 x 250 mm (3.82 x 10.63 x 9.85 in.)	136 x 270 x 251 mm (5.35 x 10.63 x 9.89 in.)	217 x 270 x 251 mm (8.54 x 10.63 x 9.89 in.)
Weight	Approx. 4.0 kg (8.8 lbs)	Approx. 5.0 kg (11.0 lbs)	Approx. 5.5 kg (12.1 lbs)	Approx. 6.0 kg (13.2 lbs)	Approx. 7.0 kg (15.4 lbs)

^{*1} For details on languages supported by pre-installed operating systems, read "The List of OS Pre-installed Languages for Multi-language" (see page 45).

^{*2} The capacity of Windows® Embedded Standard 7 CF Card is 8GB only.

*3 The serial, USB and Ethernet interfaces on this product have internal port numbers that may differ from their physical port numbers, such as "ETH1" or "USB1", printed on the product and used for identification in this manual. As the internal port number assigned to the interface differs between operating systems, please check the interface in your environment.

Ethernet Interface Example) Physical port number on this product :	ETH1	ETH2
Internal port number (Windows 7) :	LAN1	LAN2
Internal port number (Windows XP) :	LAN2	LAN1

The List of OS Pre-installed Languages for Multi-language

	Windows® XP Professional	Windows® 7 Ultimate	Windows® Embedded Standard 2009	Windows® Embedded Standard7
Arabic	✓	✓	✓	*1
Bulgarian	✓	✓	—	*1
Chinese(Simplified)	✓	✓	✓	*1
Chinese(Traditional)	✓	✓	✓	*1
Croatian	✓	✓	—	*1
Czech	✓	✓	✓	*1
Danish	✓	✓	✓	*1
Dutch	✓	✓	✓	*1
English	✓	✓	✓	✓
Estonian	✓	✓	—	*1
Finnish	✓	✓	✓	*1
French	✓	✓	✓	✓
German	✓	✓	✓	✓
Greek	✓	✓	✓	*1
Hebrew	✓	✓	✓	*1
Hungarian	✓	✓	✓	*1
Italian	✓	✓	✓	✓
Japanese	✓	✓	✓	✓
Korean	✓	✓	✓	*1
Latvian	✓	—	—	*1
Lithuanian	✓	✓	—	*1
Norwegian	✓	✓	✓	*1
Polish	✓	✓	✓	*1
Portuguese	✓	✓	✓	*1
Portuguese(Brazil)	✓	✓	✓	*1
Romanian	✓	✓	—	*1
Russian	✓	✓	✓	*1
Serbian Latin	—	✓	—	*1
Slovak	✓	✓	—	*1
Slovenian	✓	✓	—	*1
Spanish	✓	✓	✓	✓
Swedish	✓	✓	✓	*1
Thai	✓	✓	—	*1
Turkish	✓	✓	✓	*1
Ukrainian	—	✓	—	*1

*1 The languages can be downloaded from Pro-face Home Page "Otasuke Pro!".
<http://www.pro-face.com/otasuke/>

Environmental Characteristics

Characteristics

The environmental characteristics of the PS-B unit are as follows:

Characteristics	Value	Standards	
Degree of Protection	IP 20	EN/IEC 61131-2	
Pollution Degree	For use in Pollution Degree 2 environment	EN/IEC 61131-2	
Surrounding air temperature during operation	0...50 °C (32...122 °F) * ¹	EN/IEC 61131-2, UL508	
Storage temperature	- 20...60 °C (- 4...140 °F)	IEC 60068-2-2 tests Bb and Ab, IEC 60068-2-14 tests Na and EN/IEC 61131-2	
Operating altitude	2000 m (6560 ft) max	EN/IEC 61131-2	
Vibration* ²	Operation (continuous) for products with SSD or CF Card storage device.	IACS E10 and EN/IEC 60068-2-6 Fc	
			2-9 Hz: 1.5 mm 9-200 Hz: 4.9 m/s ² 5-8.4 Hz: 1.75 mm 8.4-150 Hz: 4.9 m/s ²
	Operation (continuous) for products with HDD storage device.		5-100 Hz: 1.225 m/s ²
	Operation (occasional) for products with SSD or CF Card storage device.		2-9 Hz: 3 mm 9-200 Hz: 9.8 m/s ² 5-8.4 Hz: 3.5 mm 8.4-150 Hz: 9.8 m/s ²
	Operation (occasional) for products with HDD storage device.		5-100 Hz: 2.450 m/s ²
	Merchant navy (continuous)		3-13.2 Hz: 1mm (0.04 in.) 13.2-100 Hz: 6.9 m/s ²
	Shock Resistance (in operation)		147 m/s ² / 11 ms
Surrounding air humidity during operation	10...85 % RH (Wet bulb temperature: 29 °C (84.2 °F) max. - no condensation)	EN/IEC 60068-2-78 Ca	
Storage humidity	10...85 % RH (Wet bulb temperature: 29 °C (84.2 °F) max. - no condensation)	EN/IEC 60068-2-30 Db	
Electromagnetic Compatibility (EMC)	Immunity to High Frequency Interference	EN/IEC 61131-2, IEC 61000-4x	
	Electromagnetic Emissions Class A	EN 55022/55011	

*¹ Surrounding air temperature depends on what feature or option you use.

When you use PS-B unit without FAN unit (AtomN270)

0...45°C(32... 113°F) when using Gigabit Ether

5...40°C(41... 104°F) when using DVD-RW

When you use PS-B unit with FAN unit (Core2Duo P8400)

5...50°C(41... 122°F) when using DVD-RW

*² Even when the product is used in the specifications noted above, the HDD access performance may be decreased due to the vibrational component.

Please execute an evaluation in the actual installation environment. It is recommended to use an SSD in the environment where the vibration may have an impact on the performance.

Dimensions/Assembly



Subject of this Chapter

This chapter concerns the dimensions and the panel mounting of products.

What's in this Chapter?

This chapter contains the following topics:

Topic	Page
Dimensions	48
PS-B Unit Mounting	53
Preparing to Install the PS-B Unit	58

Dimensions

Dimensions of the 1 slot Unit

The illustration below shows the dimensions of front view.

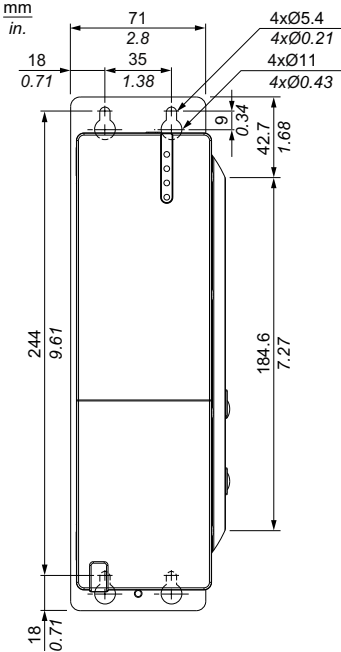

The illustration below shows the dimensions of side view.

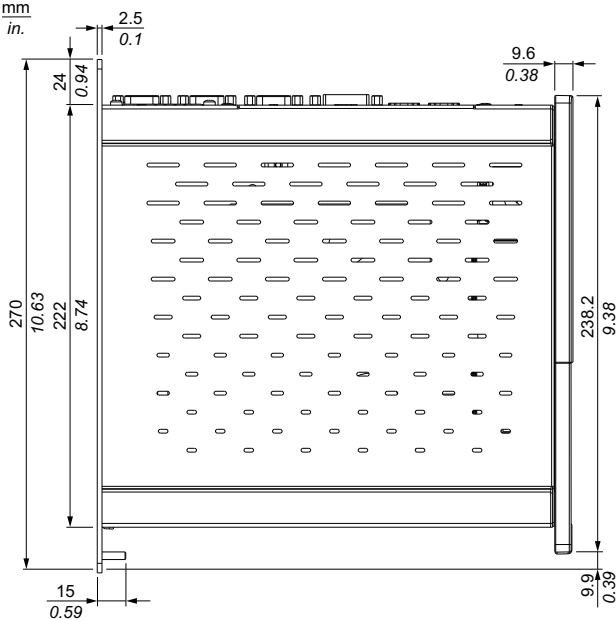

This illustration below shows the dimensions of top view.

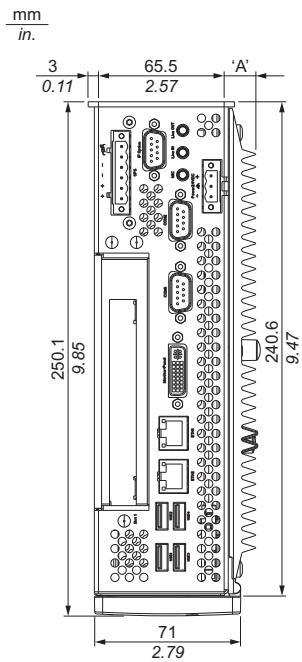

Dimensions of the 2 slot Unit

This illustration below shows the dimensions of front view.

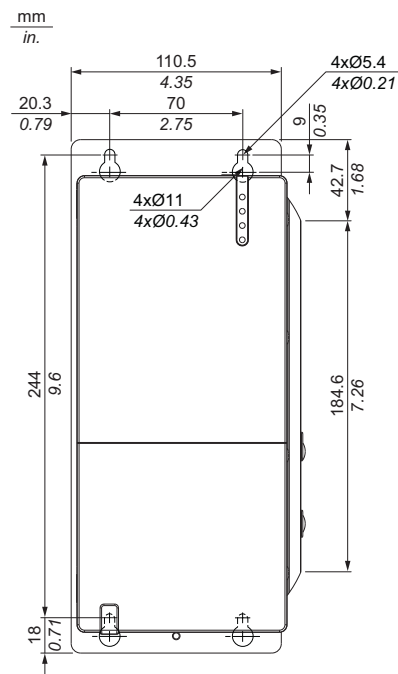

This illustration below shows the dimensions of side view.

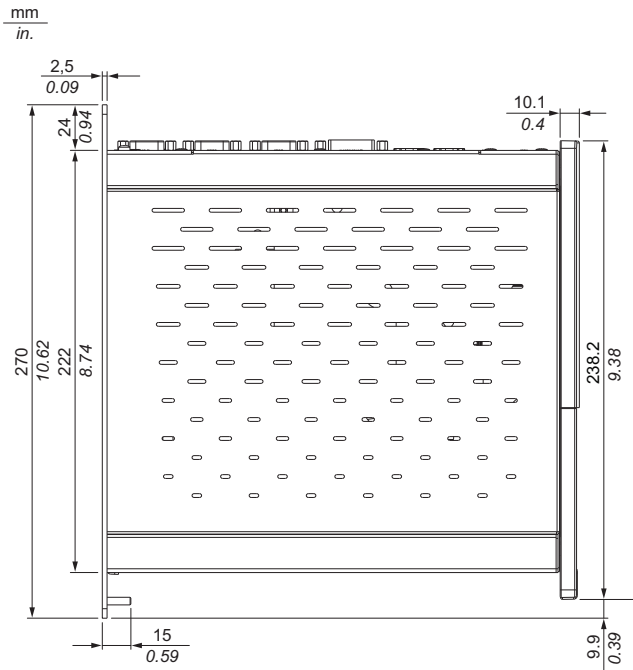

This illustration below shows the dimensions of top view.

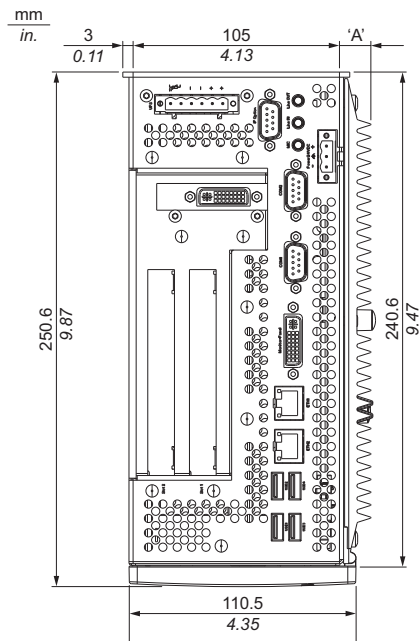

Dimensions of the 5 slot Unit

This illustration below shows the dimensions of front view.

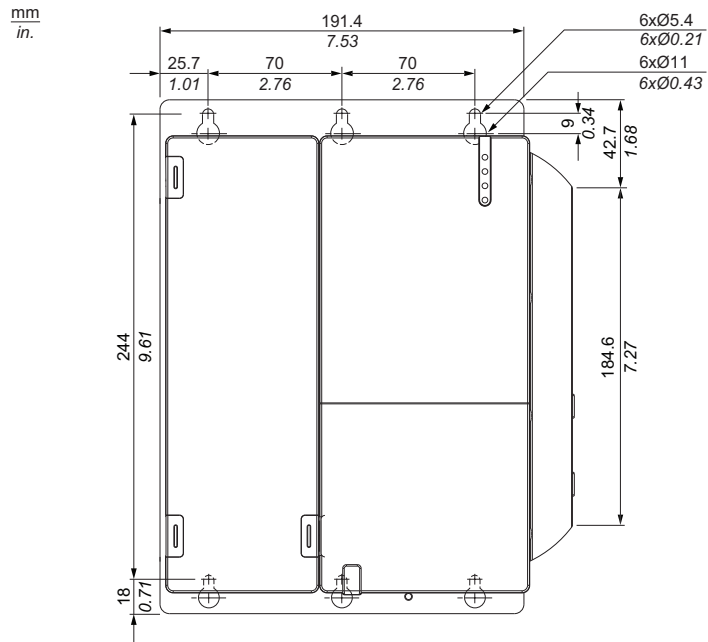

This illustration below shows the dimensions of side view.

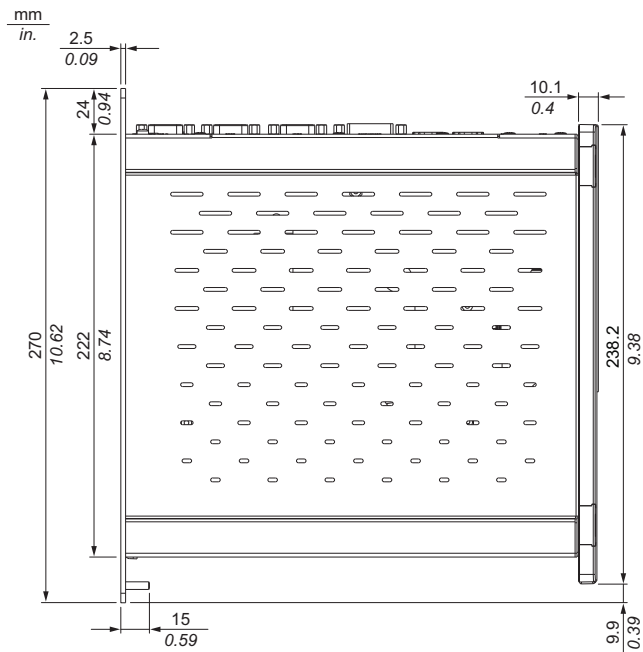

This illustration below shows the dimensions of top view.

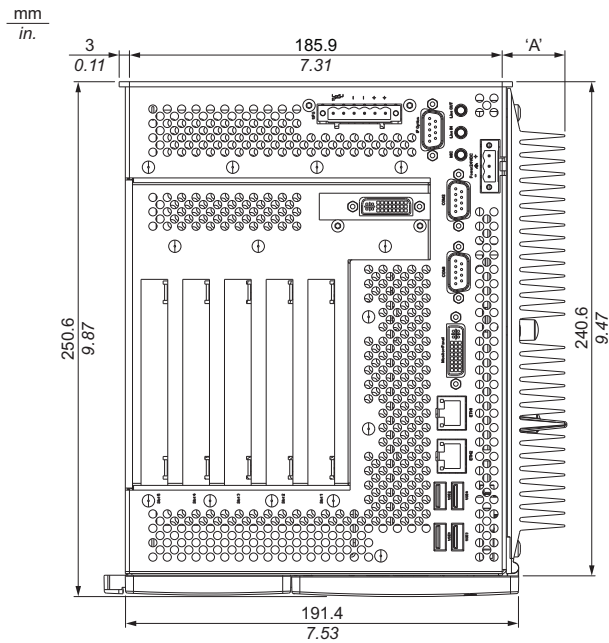

Values

Measurement "A" depends on which heat sink is used

	AtomN270	Core2Duo PS8400
1 Slot Unit	12.8mm (0.503 in)	28 mm (1.103 in)
2 Slot Unit		
5 Slot Unit	—	

Nominal measurement area	General tolerance acc. DIN ISO 2768 medium
up to 6mm (up to 0.236 in)	± 0.1 mm (± 0.004 in)
over 6 to 30 mm (over 0.236 to 1.181 in)	± 0.2 mm (± 0.0078 in)
over 30 to 120 mm (over 1.18 to 4.724 in)	± 0.3 mm (± 0.012 in)
over 120 to 400 mm (over 4.724 in to 15.747 in)	± 0.5 mm (± 0.02 in)
over 400 to 1000 mm (over 15.747 to 39.37 in)	± 0.8 mm (± 0.031 in)

PS-B Unit Mounting

Installation Location

⚠ WARNING

UNINTENDED EQUIPMENT OPERATION

Overheating can cause incorrect software behavior, therefore:

- Do not place the PS-B unit next to other devices that might cause overheating.
- Keep the PS-B unit away from arc-generating devices such as magnetic switches and non-fused breakers.
- Avoid using the PS-B unit in environments where corrosive gases are present.
- Install the PS-B unit in a location providing a minimum clearance of 50 mm (1.96 in.) on more on the left and right sides and 100 mm (3.93 in.) or more above and below the product from all adjacent structures and equipment.
- Install the PS-B unit with sufficient clearance to provide for cable routing and cable connectors.

Failure to follow these instructions can result in death, serious injury, or equipment damage.

Mount the PS-B unit system with the mounting plates found on the housing. The plates are designed for M5 screws.

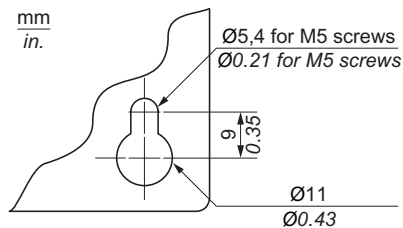

Important mounting information

- Environmental Characteristics. (see page 46)
- The PS-B unit is only permitted for operation in closed rooms.
- The PS-B unit cannot be situated in direct sunlight.
- The vent holes must not be covered.
- When mounting the device, adhere to the allowable Mounting angle (see page 56)
- Be sure the wall or switching cabinet can support a minimum four times the total weight of the PS-B unit.
- When connecting certain cable types (DVI, USB, and so on), keep the flex radius of the cable in mind.

PS-B unit 1 slot

Mounting plate outline (PS-B unit)

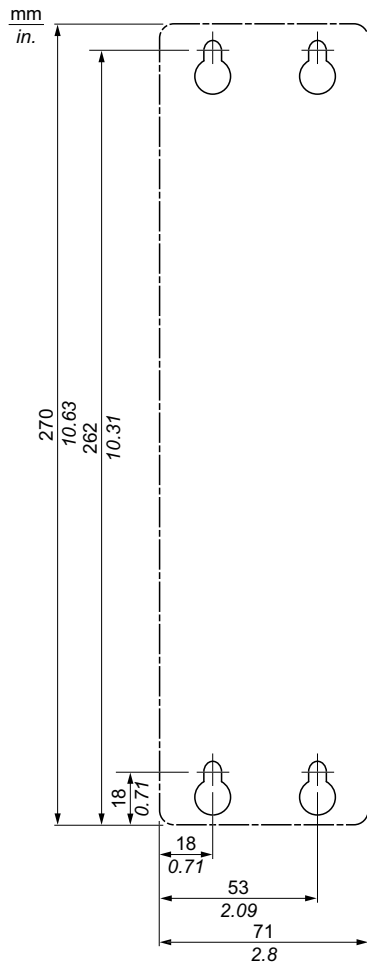

PS-B unit 2 slot

Mounting plate outline (PS-B unit)

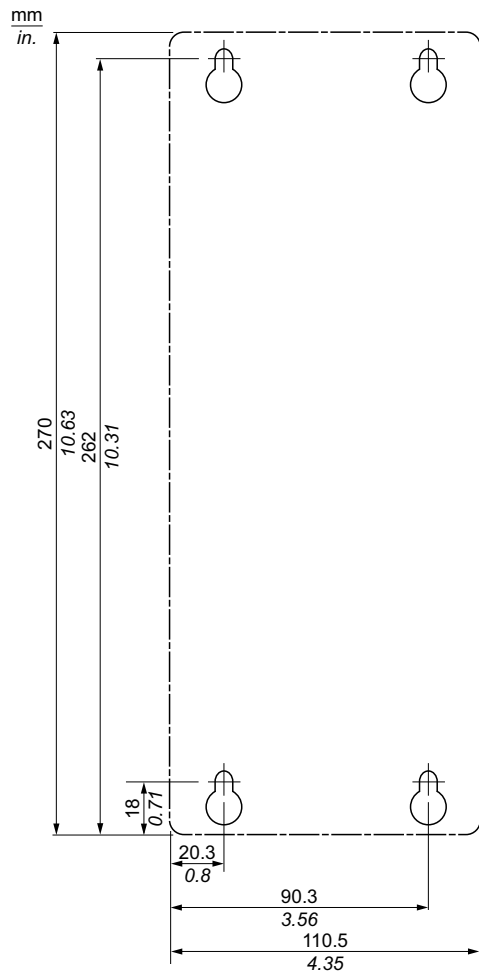

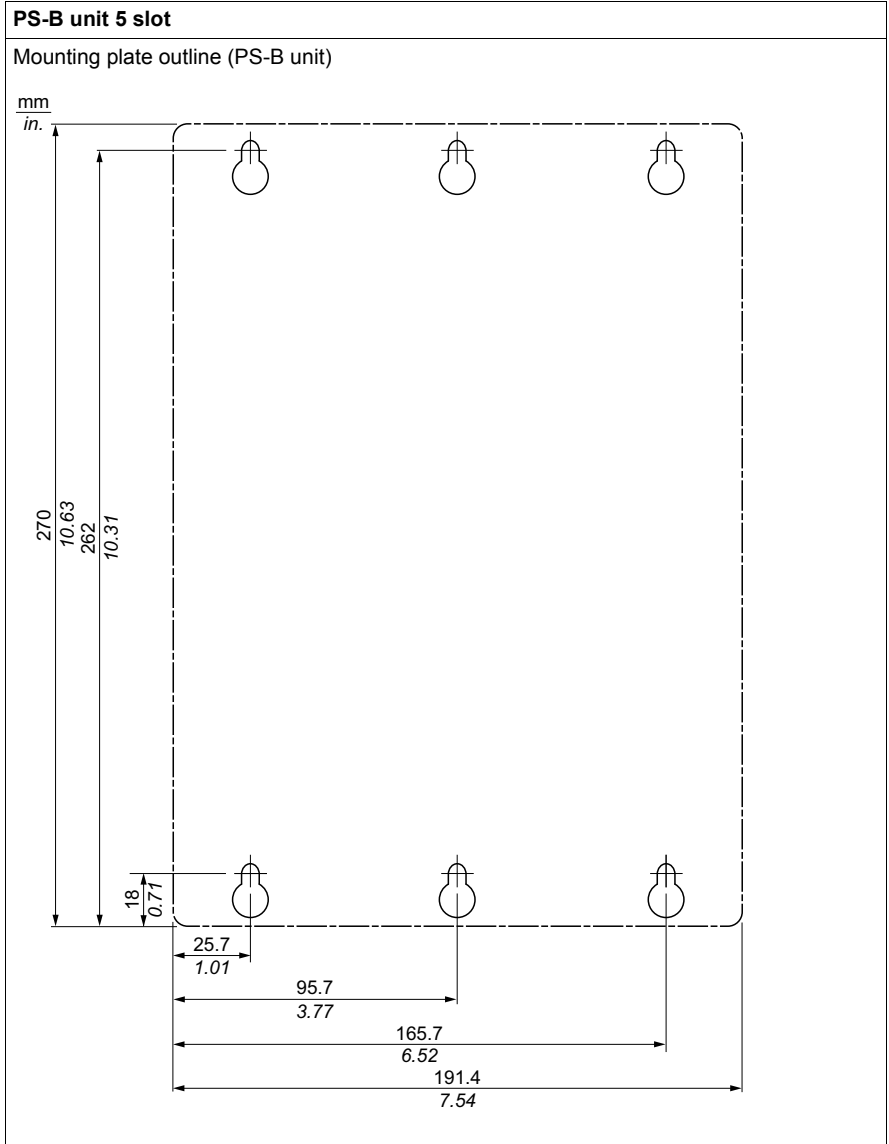

Mounting angle

The PS-B unit system must be mounted as described in the following figures.

Standard mounting - vertical

Standard mounting refers to vertical mounting orientation. PS-B unit systems with or without a fan kit can be mounted this way.

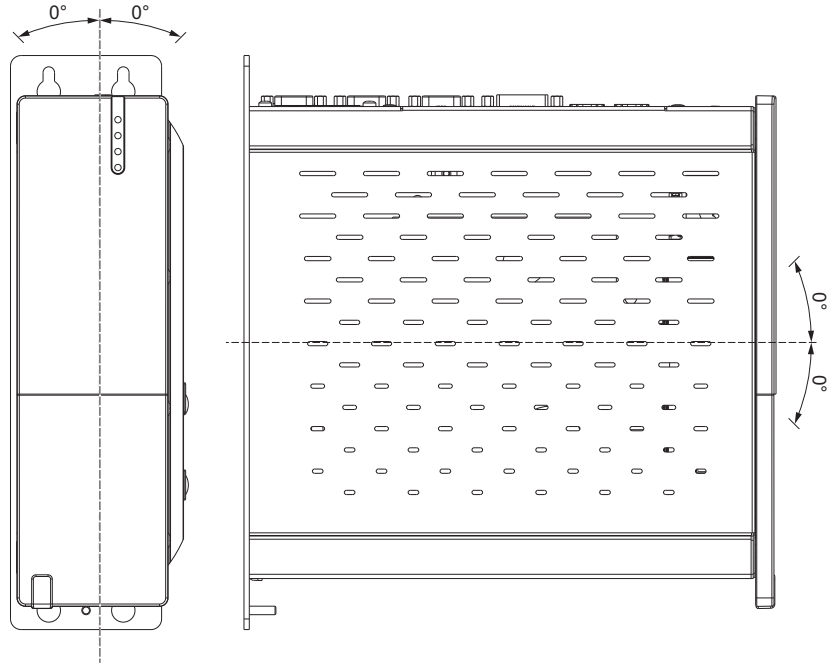

Optional mounting - flat

Operation in the optional flat mounting position (heat sink on top) is available for models with Fan kit. The maximum ambient temperature specification must be lowered by 5°C (41°F).

Do not mount models without a fan (with the Atom N270) in a flat position.

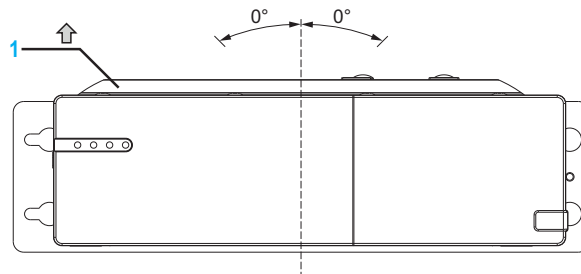

1 Heat sink

Spacing for air circulation

In order to guarantee sufficient air circulation, mount the system so that the spacing on the top, bottom, and sides is as follows:

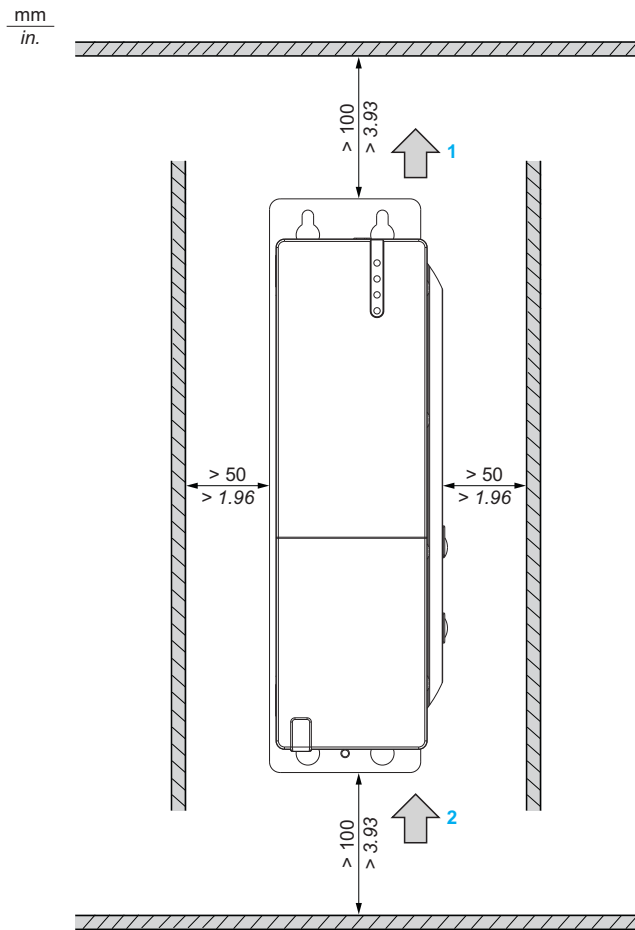

- 1 Air out
- 2 Air in

These defined distances are valid for both vertical and flat mounting of the PS-B unit.

Preparing to Install the PS-B Unit

Vibration and Shocks

Extra care should be taken with respect to vibration levels when installing or moving the PS-B unit. If the PS-B unit is moved, for example, while it is installed in a rack equipped with caster wheels, the unit can receive excessive shock and vibration.

 CAUTION
--

EXCESSIVE VIBRATION

- | |
|--|
| <ul style="list-style-type: none">● Plan your installation activities so that shock and vibration tolerances in the unit are not exceeded.● The recommended torque for mounting the PS-B unit is 0.5 N•m (4.5 lb-in). |
|--|

Failure to follow these instructions can result in injury or equipment damage.

Implementation



Subject of this Part

This part describes setting up the product.

What's in this Part?

This part contains the following chapters:

Chapter	Chapter Name	Page
5	Getting Started	61
6	Main Power Connection	63
7	Configuration of the BIOS	75
8	Hardware Modifications	89

Getting Started

5

First Power-up

License Agreement

NOTE: Limitations on your usage of the Windows® Operating System are noted in Microsoft's End User License Agreement (EULA). Please read this document before first powering-up.

On first power-up of your PS-B unit, refer to "PS4000 Series Installation Guide".

EFW Manager (Enhanced Write Filter Manager)

The PS-B unit CF Card model operating system, Windows® Embedded Standard 2009, is installed on a memory card. This card is a re-writable "Compact Flash" card that allows approximately 100,000 write operations.

The EFW Manager (Enhanced Write Filter Manager) minimizes the number of write operations to help extend the life of the CF Card. It loads temporary data (for example, system updates and software operations) into RAM, and does not write this information to the CF Card.

As a result, when using the EFW Manager, restarting the PS-B unit causes any changes the user made to the system to be cancelled. The following types of modifications may be cancelled if the EFW Manager is active and the system is restarted:

- Newly installed applications.
- Newly installed peripherals.
- Newly created or modified user accounts.
- Network configuration changes (e.g. IP address, default gateway, and so on.)
- Operating System customizations (e.g.background pictures, and so on.)

<h2><i>NOTICE</i></h2>
<p>DATA AND CONFIGURATION LOSS</p> <ul style="list-style-type: none">● Disable the EFW Manager before making any permanent changes to the hardware, software, or Operating System of the PS-B unit. Confirm that the EFW icon in the Windows system tray has a red "X".● Re-enable the EFW Manager after making permanent changes and confirm that the EFW icon in the Windows system tray does not have a red "X". This can help extend the operating life of the CF Card.● Back up all CF Card data regularly to another storage media. <p>Failure to follow these instructions can result in equipment damage.</p>

Enabling/Disabling the EWF Manager

The status of the EWF Manager may be changed by running the ChangeEWFState.exe program located in the C:\Utility\Change EWF State directory. After running this program, a system restart is required for the change to take effect. Administrator privileges are required to enable and disable the EWF Manager.

Main Power Connection

6

Subject of this Chapter

This chapter describes the connection of the PS-B unit to the main power supply.

What's in this Chapter?

This chapter contains the following topics:

Topic	Page
Grounding	64
Connecting the DC Power Cord	68
Front USB Outlet on the PS-B Unit	71

Grounding

Overview

The grounding resistance between the PS-B unit's Functional Ground (FG) and Ground must be $100\ \Omega$ or less. When using a long grounding wire, check the resistance and if required replace a thin wire with a thicker wire and place it in a duct. In addition, please refer to the table below for maximum line lengths for various wire thicknesses.

Ground Wire Dimensions

Wire Thickness	Maximum Line Length
2.5 mm ² (13 AWG)	30 m (98 ft.)
	60 m (196 ft.) round trip.

Precaution

⚠ WARNING

UNINTENDED EQUIPMENT OPERATION

- Use only the authorized grounding configurations shown below.
- Confirm that the grounding resistance is $100\ \Omega$ or less.
- Test the quality of your ground connection before applying power to the device.
Excess noise on the ground line can disrupt PS-B unit's operations.

Failure to follow these instructions can result in death, serious injury, or equipment damage.

Dedicated Ground

Connect the Functional Ground (FG) to a dedicated ground.

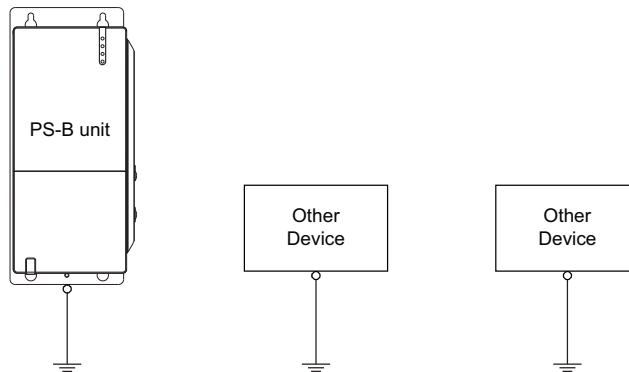

Shared Ground Allowed

If a dedicated ground is not possible, use a shared ground, as shown.

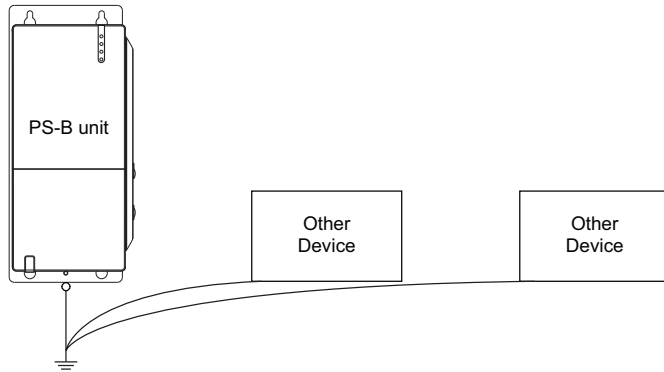

Shared Ground not Allowed

Do not connect the PS-B unit to ground through other devices using the SG terminals.

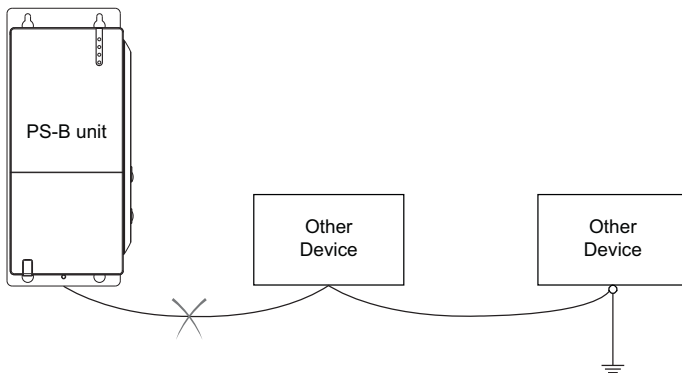

Shared Ground - Avoid Ground Loop

When connecting an external device to a PS-B unit with the Shield Ground (SG), ensure that no ground loop is created. The PS-B unit's FG and SG are connected internally.

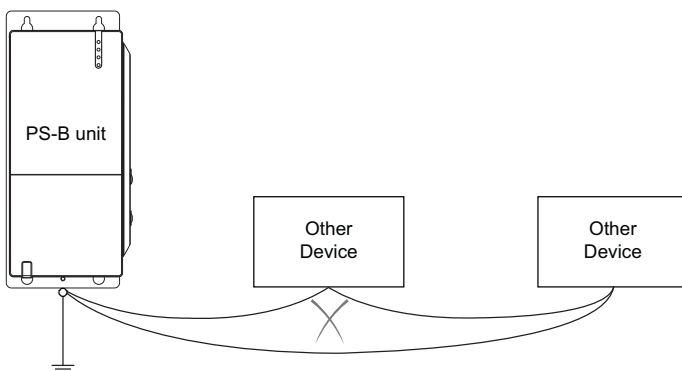

Grounding Procedure

The PS-B functional ground has 2 connections:

- Supply voltage
- Ground connection

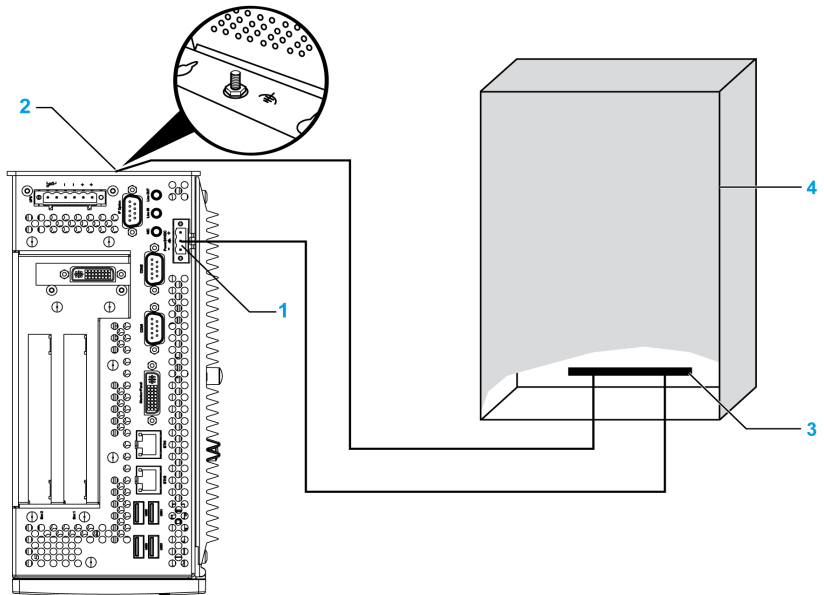

When grounding, follow the procedure below:

Step	Action
1	Check that the grounding resistance is 100 Ω or less.
2	When connecting the SG line to another device, ensure that the design of the system/connection does not produce a ground loop. Note: The SG and FG terminals are connected internally in the PS-B unit.
3	Use 2.5 mm ² (13 AWG) wire to make the ground connection. Create the connection point as close to PS-B unit as possible and make the wire as short as possible.

Grounding I/O Signal Lines

DANGER

EXPLOSION HAZARD

- Always confirm the ANSI/ISA 12.12.01 and CSA C22.2 N°213 hazardous location rating of your device before installing or using it in a hazardous location.
- To power on or power off a PS-B unit installed in a Class I, Division 2 hazardous location, you must either:
 - Use a switch located outside the hazardous environment, or
 - Use a switch certified for Class I, Division 1 operation inside the hazardous area.
- Do not disconnect equipment unless power has been switched off or the area is known to be non-hazardous. This applies to all connections including power, ground, serial, parallel, and network connections.
- Never use unshielded / ungrounded cables in hazardous locations.
- Use only non-incendive USB configuration.
- When enclosed, keep enclosure doors and openings closed at all times to avoid the accumulation of foreign matter inside the workstation.

Failure to follow these instructions will result in death or serious injury.

Electromagnetic radiation may interfere with the PS-B unit's control communications.

WARNING

UNINTENDED EQUIPMENT OPERATION

- If wiring of I/O lines near power lines or radio equipment is unavoidable, use shielded cables and ground one end of the shield to the PS-B unit's Functional Ground (FG).
- Do not wire I/O lines in proximity to power cables, radio devices, or other equipment that may cause electromagnetic interference.

Failure to follow these instructions can result in death, serious injury, or equipment damage.

Connecting the DC Power Cord

Precaution

When connecting the PS-B unit's power cable to the power connector on the unit, first ensure that the power cord is disconnected from the DC power supply.

DANGER

HAZARD OF ELECTRIC SHOCK, EXPLOSION OR ARC FLASH

- Remove all power from the device before removing any covers or elements of the system, and prior to installing or removing any accessories, hardware, or cables.
- Unplug the power cable from both the PS-B unit and the power supply.
- Always use a properly rated voltage sensing device to confirm power is off.
- Replace and secure all covers or elements of the system before applying power to the unit.
- Use only 24 Vdc when operating the PS-B unit.

Failure to follow these instructions will result in death or serious injury.

WARNING

UNINTENDED EQUIPMENT OPERATION

- Ensure that power, communication, and accessory connections do not place excessive stress on the ports. Consider the vibration environment when making this determination.
- Securely attach power, communication, and external accessory cables to the panel or cabinet.
- Use only commercially available USB cables.

Failure to follow these instructions can result in death, serious injury, or equipment damage.

Wiring and Connecting the Terminal Block (DC power supply connector)

When wiring and connecting the PS-B unit power cables, follow the procedure below:

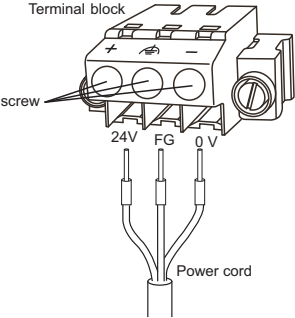
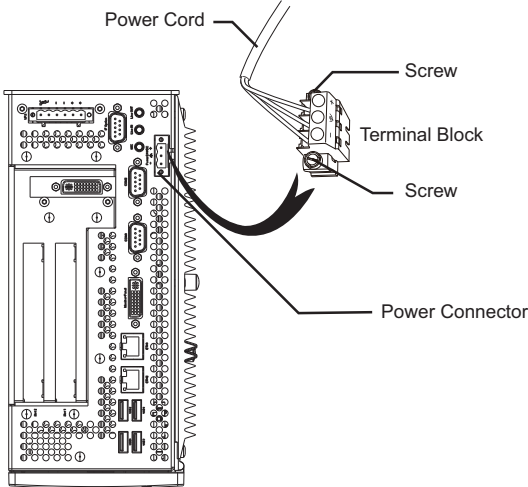
Step	Action
1	Remove all power from the PS-B unit and confirm that the DC power supply has been disconnected from its power source.
2	<p>Connect the power cord to the terminal block as shown below: Insert each pin terminal into its designated hole and tighten the screw with a small slot screw driver.</p>  <p>Use wire with</p> <ul style="list-style-type: none"> ● copper conductors only ● cross-section 0.75 mm² to 2.0 mm² (AWG18 to AWG14) ● maximum operating temperature not less than 75 °C (167 °F)
3	<p>Place the terminal block in the power connector and tighten the screws. The recommended torque to tighten these screws is 0.5 N•m (4.5 lb-in):</p> 

Marine Certification Connection

If the product is used in an environment requiring marine certification, a noise filter must be in the power line. The noise filter must be ordered in addition to the product using the reference PFXZFTPND1.

Possible Connections

Connection to a Floating (Ungrounded) DC Power System:

Some specific applications require the use of a floating (ungrounded) power system. The characteristics of such a system, are as follows:

- The 0 Vdc power line and Functional Ground (FG) are connected internally.
- The 24 Vdc power line is isolated from the FG and from the outputs. The dielectric strength for these are:
 - Primary/Secondary: 1000 Vac
 - Primary/Ground: 1000 Vac

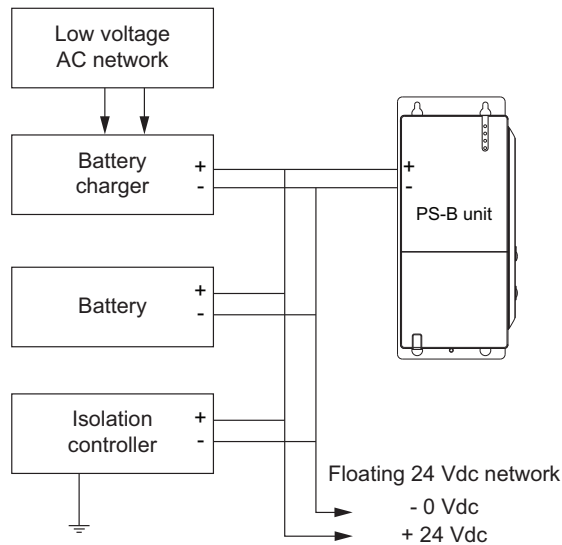

Connection to a Ground-Referenced DC Power System:

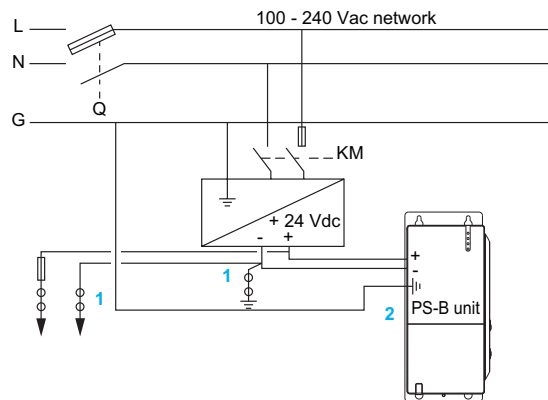

Q : Main Power Contact

KM : Line contacts

(1) : Residual Current Detector for detecting grounding faults

(2) : PS-B unit

USB Outlet on the PS-B Unit

Introduction

The information below describes usage of the USB outlet located on PS-B unit in Class I, Division 2 Groups A, B, C, and D hazardous locations.

DANGER

EXPLOSION HAZARD

- Always confirm the ANSI/ISA 12.12.01 and CSA C22.2 N°213 hazardous location rating of your device before installing or using it in a hazardous location.
- To power on or power off a PS-B unit installed in a Class I, Division 2 hazardous location, you must either:
 - Use a switch located outside the hazardous environment, or
 - Use a switch certified for Class I, Division 1 operation inside the hazardous area.
- Do not disconnect equipment unless power has been switched off or the area is known to be non-hazardous. This applies to all connections including power, ground, serial, parallel, and network connections.
- Never use unshielded / ungrounded cables in hazardous locations.
- Use only non-incendive USB configuration.
- When enclosed, keep enclosure doors and openings closed at all times to avoid the accumulation of foreign matter inside the workstation.

Failure to follow these instructions will result in death or serious injury.

WARNING

EQUIPMENT DISCONNECTION OR UNINTENDED EQUIPMENT OPERATION

- Ensure that power, communication, and accessory connections do not place excessive stress on the ports. Consider the vibration environment when making this determination.
- Securely attach power, communication, and external accessory cables to the panel or cabinet.
- Use only commercially available USB cables.

Failure to follow these instructions can result in death, serious injury, or equipment damage.

Description

Non-incendive equipment (keyboards, mouse) are permitted for use on the PS-B unit (Associated Apparatus) USB ports 1, 2, 3, 4 (not for USB 5, only for maintenance). In addition to being non-incendive, any equipment connected to the USB ports 1, 2, 3, 4 must satisfy the following criteria. The following figure shows the USB cable wiring.

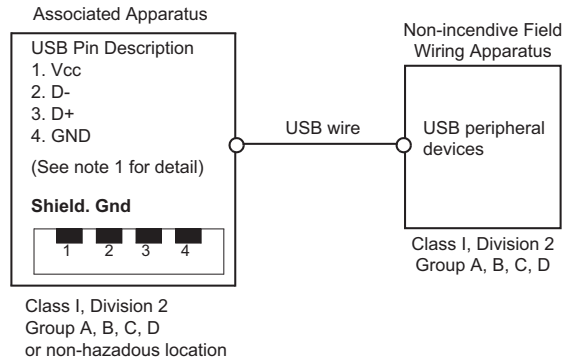

Notes:

- The following table gives the Non-incendive Circuit Parameters:

	USB Ports 1 and 3	USB Ports 2 and 4
Open-circuit voltage = V_{oc}	5.066 V	5.26 V
Short-circuit current = I_{sc}	1320 mA	830 mA
Associated capacitance = C_a	20 μ F	20 μ F
Associated inductance = L_a	16.8 μ H	16.8 μ H

The Entity Concept allows interconnection of non-incendive apparatus with associated apparatus not specifically examined combinations as a system when the approved values of V_{oc} (or U_o) and I_{sc} (or I_o) for the associated apparatus are less than or equal to V_{max} (U_i) and I_{max} (I_i) for the non-incendive apparatus and the approved values of C_a (C_o) and L_a (L_o) for the associated apparatus are greater than or equal to $C_i + C_{cable}$ and $L_i + L_{cable}$, respectively, for the non-incendive field wiring apparatus.

2. Associated Non-incendive Field Wiring Apparatus shall satisfy the following:

PS-B Unit	-	Associated Non-incendive Field Wiring Apparatus (Mouse, Keyboard)
V_{oc}	\leq	V_{max}
I_{sc}	\leq	I_{max}
C_a	\geq	$C_i + C_{cable}$
L_a	\geq	$L_i + L_{cable}$

3. If the electrical parameters of the cable are unknown, the following values may be used:

- $C_{cable} = 196.85 \text{ pF/m (60 pF/ft)}$
- $L_{cable} = 0.656 \text{ } \mu\text{H/m (0.20 } \mu\text{H/ft)}$.

4. Wiring methods must be in accordance with the electrical code of the country in use.

The PS-B unit must be installed in an enclosure. If installed in a Class I, Division 2 Location, the enclosure must be capable of accepting one or more Division 2 wiring methods.

DANGER

EXPLOSION HAZARD

- Substitution of components may impair suitability for Division 2 hazardous(classified) locations.
- Do not energize or disconnect the device while area is known to be hazardous.
- The associated non-incendive field wiring apparatus shall not be connected in parallel unless permitted by the associated non-incendive apparatus approval.

Failure to follow these instructions will result in death or serious injury.

The PS-B unit is suitable for use in Class I, Division 2, Groups A, B, C, D and provides non-incendive field wiring to apparatus in Class I, Division 2, Groups A, B, C, D.

Configuration of the BIOS



What's in this Chapter?

This chapter contains the following topics:

Topic	Page
BIOS Options	76
USB Configuration	81
Boot Menu	83
Security	85
Exit	88

BIOS Options

General Information

BIOS stands for "Basic Input Output System". It is the most basic communication between the user and the hardware.

The BIOS Setup Utility lets you modify basic system configuration settings. These settings are stored in CMOS and in an EEPROM (as a backup).

The CMOS data is buffered by a battery (if present), and remains in the PS-B unit even when the power is turned off (24 Vdc power supply is disconnected).

BIOS Setup and Boot Procedure

BIOS is immediately activated when switching on the power supply of the PS-B unit or pressing the power button. The system checks if the setup data from the EEPROM is "OK". If the data is "OK", then it is transferred to the CMOS. If the data is "not OK", then the CMOS data is checked for validity. A message appears if the CMOS data contains anomalies, but you can continue the boot procedure by pressing the [F1] key. To prevent the message from appearing at each restart, open the BIOS setup by pressing the [Del] key and re-save the settings.

BIOS reads the system configuration information in CMOS RAM, checks the system, and configures it using the Power On Self Test (POST).

When these "preliminaries" are complete, the BIOS seeks the operating system from the data storage devices available (hard drive, floppy drive, etc.). BIOS launches the operating system and hands over to the operating system control of system operations.

To enter BIOS Setup, the [DEL] key must be pressed after the USB controller has been initialized as soon as the following message appears on the monitor (during POST):

"Press DEL to run SETUP"



```
Press DEL to run Setup
Press F11 for BIOS POPUP
The MCH is operating with DDR2-677/CL5 in Dual-Channel Interleaved Mode
Initializing USB Controllers .. Done
2048MB OK
USB Device(s) : 1 Keyboard, 1 Hub
Auto-Detecting Sec Master..IDE Hard Disk
Auto-Detecting Sec Slave..IDE Hard Disk
Sec Master: SILICONSYSTEMS INC 4GB 240-0230
Sec Slave : SILICONSYSTEMS INC 4GB 240-0230
Auto-Detecting USB Mass Storage Devices ..
00 USB mass storage devices found an configured.
```

BIOS Setup Keys

The following keys are enabled during the POST:

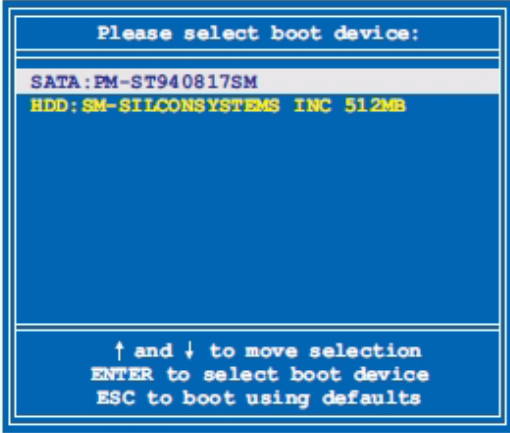
Key	Function
Del	Enters the BIOS setup menu
F12	Using the F12 key, you can boot from the network
F11	Displays the boot menu. Lists all bootable devices that are connected to the system. With cursor ↑ and cursor ↓ and by pressing <ENTER>, select the device used for the boot. 
Pause	Pressing the [pause] key stops the POST. Press any other key to resume the POST.

NOTE: The key signals from the USB keyboard are only registered after the USB controller has been initialized.

The following keys can be used after entering the BIOS setup:

Key	Function
F1	General help.
Cursor ↑	Moves to the previous item.
Cursor ↓	Goes to the next item.
Cursor ←	Moves to the previous item.
Cursor →	Goes to the next item.
±	Changes the value of the selected item.
Enter	Changes to the selected menu.
PgUp ↑	Changes to the previous page.
PgDn ↓	Changes to the next page.
Start	Jumps to the first BIOS menu item or object.
End	Jumps to the last BIOS menu item or object.
F2/F3	Switches the colors of the BIOS setup.
F7	Resets any changes.
F9	Loads these settings for all BIOS configurations.
F10	Saves and closes.
Esc	Exits the submenu.

Main

Immediately after the [DEL] key is pressed during startup, the main BIOS setup menu appears:

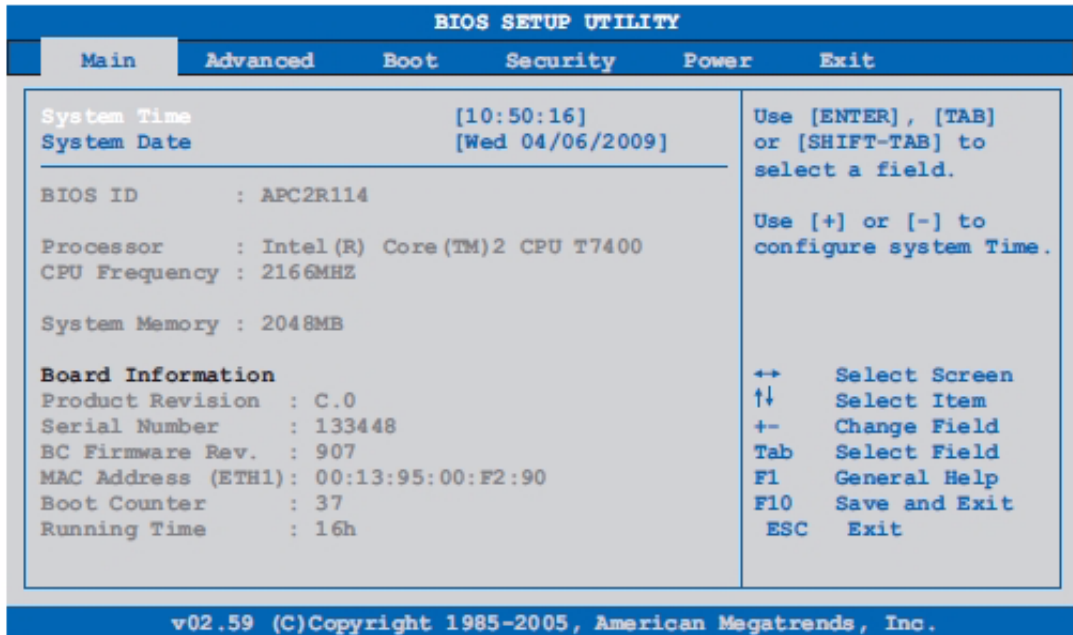

BIOS setting	Description	Setting options	Effect
System Time	This is the current time setting. The time is maintained by the battery (CMOS battery) when the unit is turned off.	Adjustment of the time	Set the time in the format Hour:Minute:Second (hh:mm:ss).
System Date	This is the current date setting. The time is maintained by the battery (CMOS battery) when the unit is turned off.	Changes to the date	Set the date in the format Month:Day:Year (mm:dd:yyyy)
BIOS ID	Displays the BIOS detected.	None	-
Processor	Displays the processor type	None	-
CPU frequency	Displays the processor frequency	None	-
System memory	Displays the system memory size	None	-
Product revision	Displays the CPU board HW revision.	None	-
Serial number	Displays the CPU board serial number.	None	-
BC Firmware rev.	Displays the CPU board controller firmware revision.	None	-

BIOS setting	Description	Setting options	Effect
MAC Adresse (ETH1)	Displays the MAC addresses assigned for the ETH1 interface.	None	-
Boot counter	Displays the boot counter - each restart increments the counter by one (max.16777215).	None	-
Running time	Displays the running time in hours. (max. 65535).	None	-

Advanced

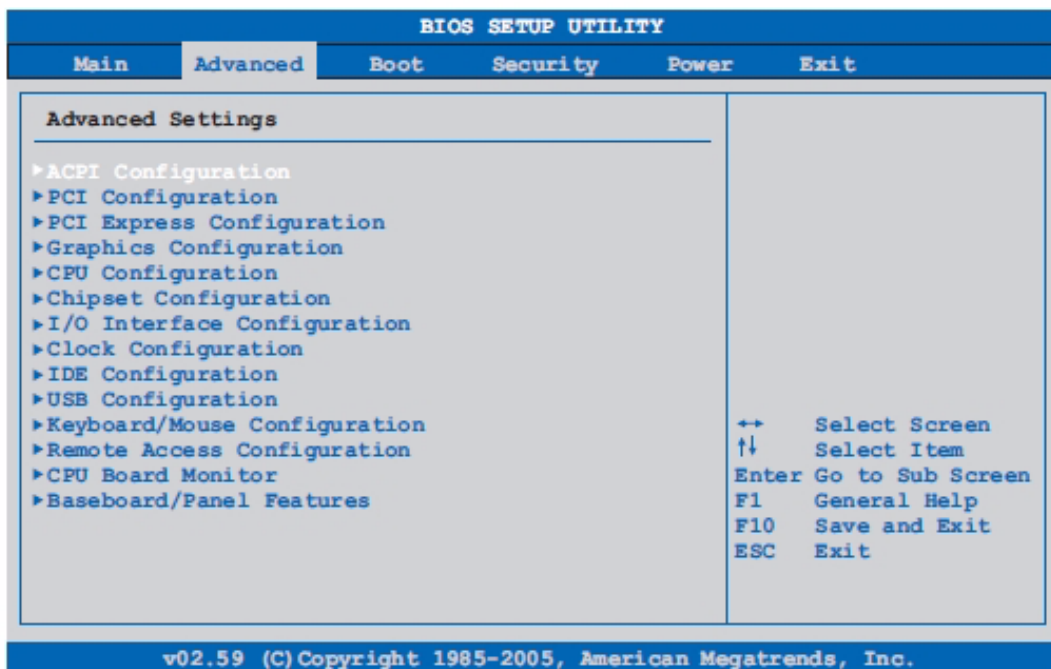

BIOS setting	Description	Setting options	Effect
ACPI configuration	Configures ACPI devices.	Enter	Opens submenu
PCI configuration	Configures PCI devices.	Enter	Opens submenu
PCI Express Configuration	Configures the PCI Express.	Enter	Opens submenu
Graphics configuration	Configures the graphic settings.	Enter	Opens submenu
CPU configuration	Configures CPU settings.	Enter	Opens submenu
Chipset configuration	Configures the chipset functions.	Enter	Open submenu
I/O interface configuration	Configures the I/O devices.	Enter	Opens submenu
Clock configuration	Configures clock settings.	Enter	Opens submenu
IDE Configuration	Configures the IDE functions.	Enter	Opens submenu

BIOS setting	Description	Setting options	Effect
USB configuration	Configures USB settings	Enter	Opens submenu
Keyboard/mouse configuration	Configures the keyboard/mouse options	Enter	Opens submenu
Remote access configuration	Configures the remote access settings.	Enter	Opens submenu
CPU board monitor	Displays the current voltage and temperature of the processor	Enter	Opens submenu
Baseboard/panel features	Displays device specific information and setup of device specific values.	Enter	Opens submenu

USB Configuration

USB Configuration

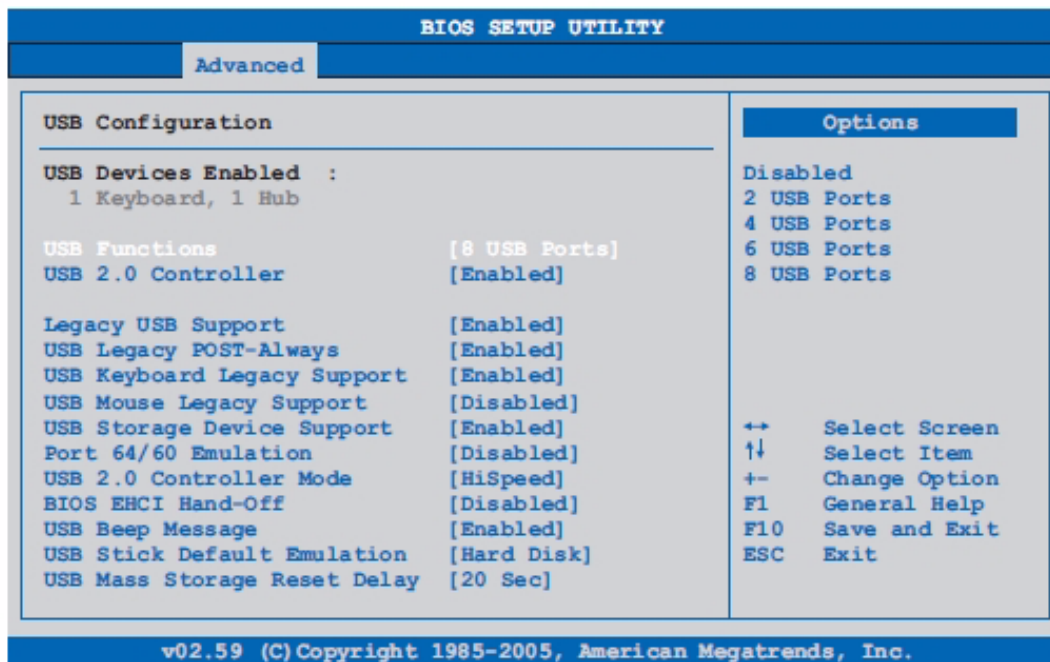

BIOS setting	Description	Setting options	Effect
USB Functions	You can enable or disable USB ports here. USB port numbers (e.g. USB1, USB3, and so on) are printed on the PS-B unit housing.	Disabled	Disables the USB port
		2 USB ports	USB1, USB3 are enabled.
		4 USB ports	USB1, USB2, USB3, USB4, are enabled.
		6 USB ports	USB1, USB2, USB3, USB4, USB5 are enabled
		8 USB ports	
USB 2.0 Controller	Option for enabling or disabling USB 2.0.	Enabled	All USB interfaces run in USB 2.0 mode.
		Disabled	All USB interfaces run in USB 1.1 mode.
Legacy USB Support	Legacy USB support can be enabled/disabled here. USB interfaces do not function during startup. USB is supported after the operating system has started. A USB keyboard is recognized during the POST.	Disabled	Disables this function.
		Enabled	Enables this function.
		Auto	Automatic enabling.

BIOS setting	Description	Setting options	Effect
USB Legacy POST-Always	Option to enable Legacy USB Support during the POST (Power On Self Test), the same as the Legacy USB Support setting.	Enabled	Enables calling the BIOS Setup during the POST with a USB keyboard
		Disabled	Disables this function
USB Keyboard Legacy Support	USB keyboard support can be enabled/disabled here.	Disabled	Disables this function
		Enabled	Enables this function
USB Mouse Legacy Support	USB mouse support can be enabled/disabled here.	Disabled	Disables this function.
		Enabled	Enables this function.
USB Storage Device Support	USB storage device support can be enabled/disabled here.	Disabled	Disables this function.
		Enabled	Enables this function.
Port 64/60 Emulation	Port 64/60 emulation can be enabled/disabled here.	Disabled	USB keyboard functions in all systems excluding Windows NT.
		Enabled	USB keyboard functions in Windows NT.
USB 2.0 Controller Mode	Defines settings for the USB controller.	Full speed	12 Mbps
		Hi speed	480 Mbps
BIOS EHCI Hand-Off	Defines operating system support for the fully automatic EHCI function.	Disabled	Disables this function.
		Enabled	Enables this function.
USB Beep Message	Option for outputting a tone each time a USB device is detected by the BIOS during the POST.	Disabled	Disables this function.
		Enabled	Enables this function.
USB Stick Default Emulation	You can set how the USB device will be used.	Auto	USB devices with less than 530MB of memory are simulated as floppy disk drives. Devices with larger capacities are simulated as hard drives.
		Hard disk	An HDD-formatted drive (such as Zip drive) can be used as a FDD for starting the system.
USB Mass Storage Reset Delay	You can define the amount of time the USB device POST waits after the device start command. NOTE: The message "No USB mass storage device detected" will appear if no USB memory device is installed.	10 Sec, 20 Sec, 30 Sec, 40 Sec	Manually define the delay time.

Boot Menu

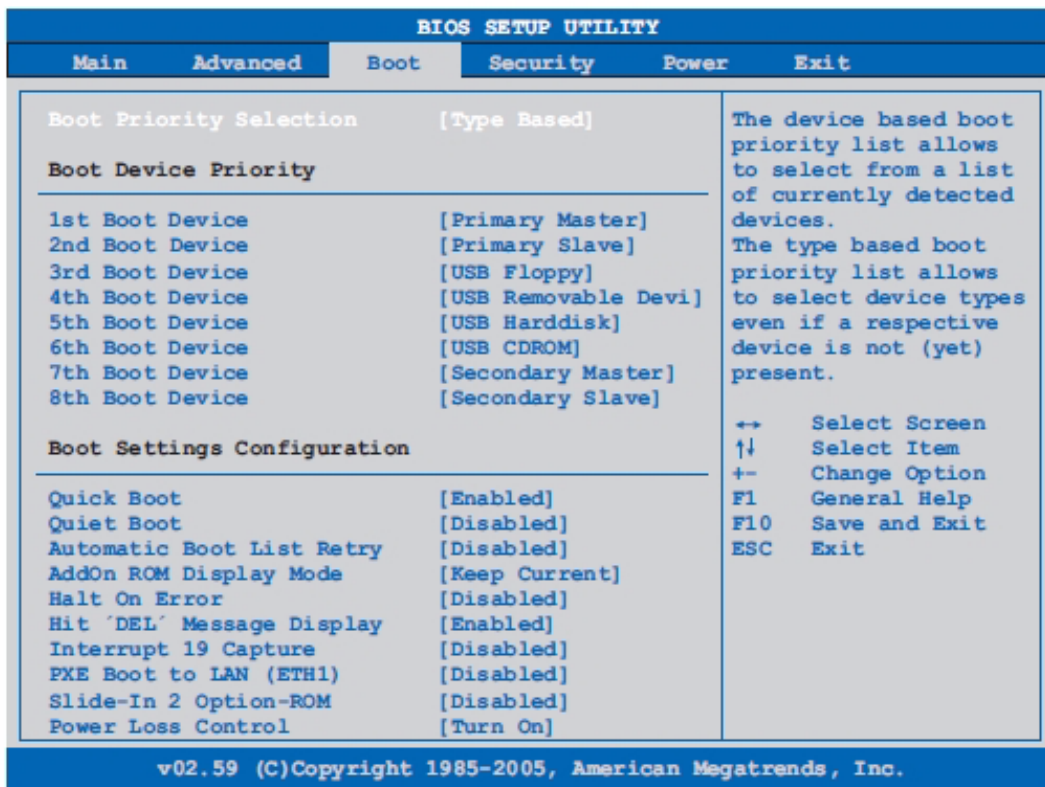

Boot setting	Description	Setting options	Effect
Boot Priority Selection	You can define the drive used to boot up the machine.	Device based	Only devices that are recognized by the system are listed. You can change the sequence of items in the device list.
		Type based	You can change the sequence of items in the device list. You can add to the list device types that are not connected.
1st boot device	Use this option to define the boot drive.	Disabled, Primary Master, Primary Slave, Secondary Slave, Legacy Floppy, USB Floppy, USB CDROM, USB Removable Device, Onboard LAN, External LAN, PCI Mass Storage, PCI SCSI Card, Any PCI, BEV Device, Third Slave, PCI RAID, Local BEV ROM	Select the desired boot sequence.
2nd boot device			
3rd boot device			
4th boot device			
5th boot device			
6th boot device			
7th boot device			
8th boot device			

Boot setting	Description	Setting options	Effect
Quick Boot	This function reduces the boot time by skipping some POST procedures.	Disabled	Disables this function.
		Enabled	Enables this function.
Quiet Boot	Determines if POST message or OEM logo (default = Black background) is displayed.	Disabled	POST message display
		Enabled	OEM logo display instead of POST message.
Automatic Boot List Retry	With this option, the operating system attempts to automatically restart following startup failure.	Disabled	Disables this function.
		Enabled	Enables this function.
Add On ROM Display Mode	Sets the display mode for ROM (during the boot procedure).	Force BIOS	Displays an additional BIOS part.
		Keep Current	Displays BIOS information.
Hold On Errors	This option sets whether the system should pause the Power On Self Test (POST) when it encounters an anomaly.	Disabled	The system does not pause. Ignores all anomalies.
		Enabled	System pause. The system pauses every time an anomaly is encountered.
Hit 'DEL' Message Display	You can define to display the "Hit 'DEL' Message" on startup. NOTE: When Quiet Boot is enabled, the message will not display.	Disabled	The message does not displayed.
		Enabled	The message will display.
Interrupt 19 Capture	Controls BIOS interrupt.	Disabled	Disables this function.
		Enabled	Enables this function.
PXE Boot to LAN (ETH1)	Enables/disables the ability to boot from LAN (ETH1).	Disabled	Disables this function.
		Enabled	Enables this function.
Slide-In 2 Optional ROM	Enables/disables optional ROM for a slide-in 2 drive.	Disabled	Disables this function.
		Enabled	Enables this function.
Power Loss Control	Determines if the system turns on/off following power loss.	Remain Off	Remains off
		Turn On	Powers on
		Last State	Enables the previous state.

Security

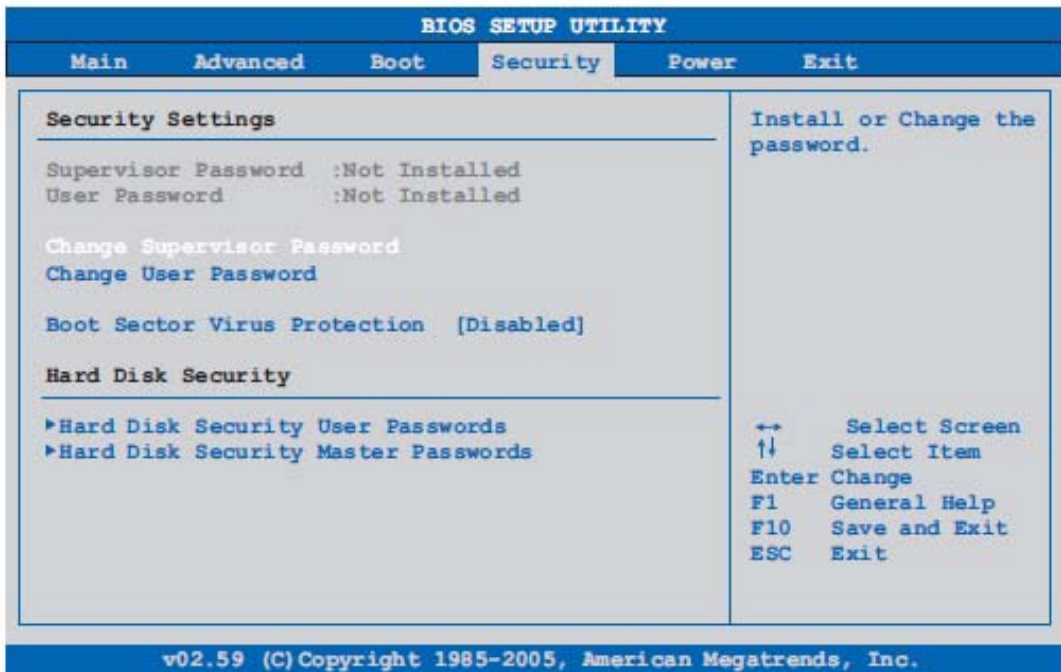

BIOS Setting	Description	Setting options	Effect
Supervisor Password	Displays whether or not a supervisor password has been set.	None	-
User Password	Displays whether or not a user password has been set.	None	-
Change Supervisor Password	Required to enter/change the supervisor password. A supervisor password is necessary to edit BIOS settings.	Enter	Enter password.
Change User Password	To enter/change a user password. A user password allows the user to edit certain BIOS settings.	Enter	Enter password.

BIOS Setting	Description	Setting options	Effect
Boot Sector Virus Protection	With this option, a warning is issued when the boot sector is accessed through a program or virus. NOTE: With this option, only the boot sector, not the entire hard drive, is protected.	Disabled	Disables this function.
		Enabled	Enables this function.
Hard Disk Security User Password	You can create the hard disk security user password here.	Enter	Opens submenu.
Hard Disk Security Master Password	You can create the hard disk security master password here.	Enter	Opens submenu.

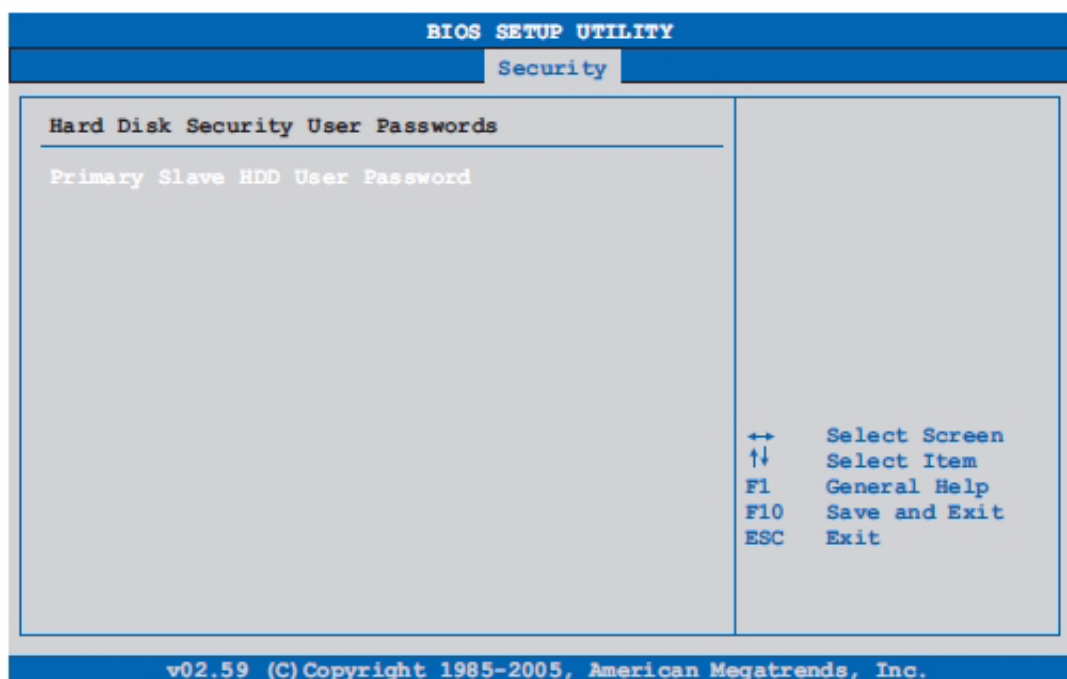

BIOS setting	Description	Setting options	Effect
Primary Slave HDD User Password	With a valid user password, you can change or configure hard drives without rebooting the device. A user password allows the user to edit specific BIOS settings.	Enter	Enter password

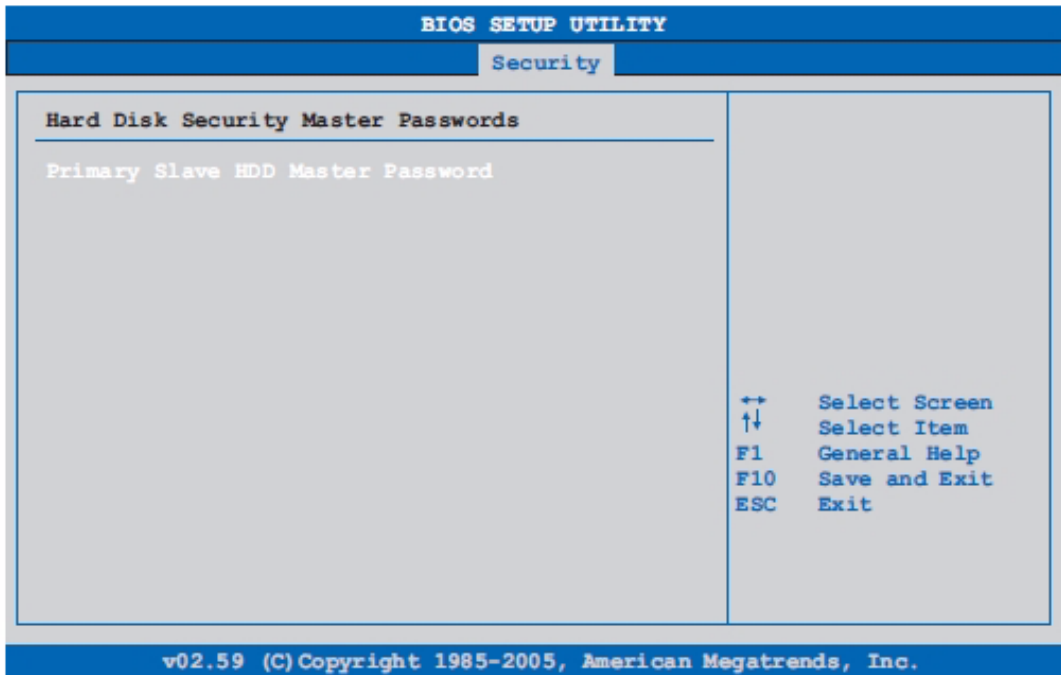

BIOS setting	Description	Setting options	Effect
Primary Slave HDD Master Password	With a valid user password, you can change or configure hard drives without rebooting the device.	Enter	Enter password

Exit

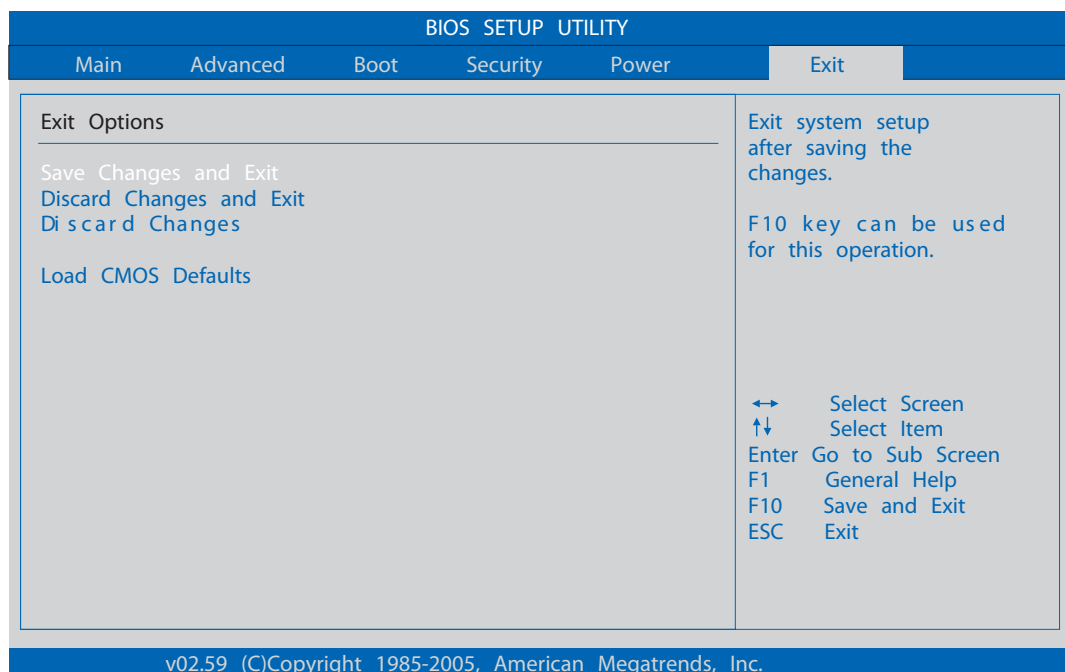

BIOS setting	Description	Setting options	Effect
Save Changes and Exit	Displays a confirmation message box. On confirming you want to save changes to the BIOS settings, saves the new settings to CMOS, and restarts the system..	OK / Cancel	-
Discard Changes and Exit	Exits the BIOS settings without making any changes, and restarts the system.	OK / Cancel	-
Discard Changes	Restores the previously saved BIOS settings and discards any changes that were made during the current session.	OK / Cancel	-
Load CMOS Defaults	Loads the CMOS default values, defined by the CMOS profile switch settings. This command loads CMOS default values for all BIOS configurations.	OK / Cancel	-

BIOS default settings

The CMOS profile switches, located on the front side of the unit near the LEDs, are used to load pre-defined BIOS profile settings, which are based on the position of the switches.

The switch positions at delivery represents the optimum BIOS default values and should not be changed.

Hardware Modifications



8

Subject of this Chapter

This chapter concerns the hardware modifications for the PS-B unit.

A wide variety of optional units, Main Memory and CF Cards manufactured by Pro-face and commercial devices and boards can be used with this product.

What's in this Chapter?

This chapter contains the following topics:

Topic	Page
Before Modifications	90
Uninterruptible Power Supply (UPS)	92
PCI / PCIe Card Installation	99
Compact Flash (CF) Card Installation and Removal	105
Fan Kit Installation	107

Before Modifications

Overview

For detailed installation procedures for optional units, refer to the Installation Guide included with the optional unit.

DANGER

HAZARD OF ELECTRIC SHOCK, EXPLOSION OR ARC FLASH

- Remove all power from the device before removing any covers or elements of the system, and prior to installing or removing any accessories, hardware, or cables.
- Unplug the power cable from both the PS-B unit and the power supply.
- Always use a properly rated voltage sensing device to confirm power is off.
- Replace and secure all covers or elements of the system before applying power to the unit.
- Use only 24 Vdc when operating the PS-B unit.

Failure to follow these instructions will result in death or serious injury.

DANGER

EXPLOSION HAZARD

- Always confirm the ANSI/ISA 12.12.01 and CSA C22.2 N°213 hazardous location rating of your device before installing or using it in a hazardous location.
- To power on or power off a PS-B unit installed in a Class I, Division 2 hazardous location, you must either:
 - Use a switch located outside the hazardous environment, or;
 - Use a switch certified for Class I, Division 1 operation inside the hazardous area.
- Do not disconnect equipment unless power has been switched off or the area is known to be non-hazardous. This applies to all connections including power, ground, serial, parallel, and network connections.
- Never use unshielded / ungrounded cables in hazardous locations.
- Use only non-incendive USB configuration.
- When enclosed, keep enclosure doors and openings closed at all times to avoid the accumulation of foreign matter inside the workstation.

Failure to follow these instructions will result in death or serious injury.

WARNING

RISK OF BURNING INJURY

During operation, surface temperatures of the heat sink may reach 70°C (158°F). Do not touch the surface of the heat sink during operation.

Failure to follow these instructions can result in death, serious injury, or equipment damage.

⚠ CAUTION

OVERTORQUE AND LOOSE HARDWARE

- Do not exert more than 0.5 N•m (4.5 lb-in) of torque when tightening the installation fastener, enclosure, accessory, or terminal block screws. Tightening the screws with excessive force can damage the plastic casing of the PS-B unit.
- When installing or removing screws, ensure that they do not fall inside the PS-B unit's chassis.

Failure to follow these instructions can result in injury or equipment damage.

⚠ CAUTION

STATIC SENSITIVE COMPONENTS

PS-B unit internal components, including accessories such as RAM modules and expansion boards, can be damaged by static electricity.

- Keep static-producing materials (plastic, upholstery, carpeting) out of the immediate work area.
- Do not remove ESD-sensitive components from their anti-static bags until you are ready to install them.
- When handling static-sensitive components, wear a properly grounded wrist strap (or equivalent).
- Avoid unnecessary contact with exposed conductors and component leads with skin or clothing.

Failure to follow these instructions can result in injury or equipment damage.

Uninterruptible Power Supply (UPS)

Overview

The Uninterruptible Power Supply (UPS) option is only available for PS-B. The following figure shows a PS-B equipped with the UPS option:

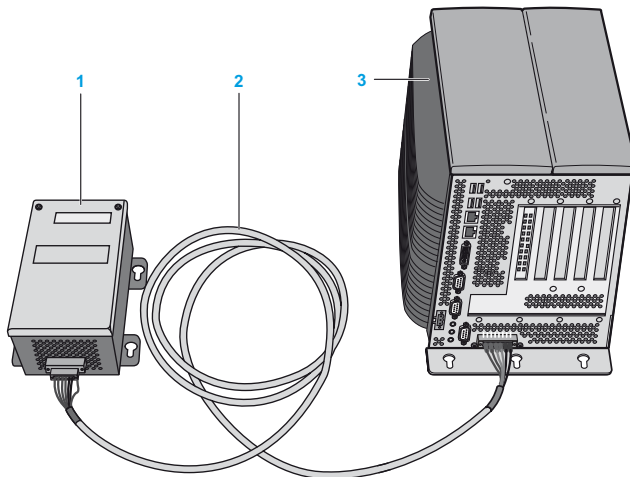

- 1 UPS battery unit
- 2 UPS connection cable 3 m (9.84 ft)
- 3 PS-B with UPS Interface Board (pre-installed)

NOTE:

When using a model with an integrated UPS module, connect the UPS battery unit before starting up the PS-B. If the PS-B is started before the UPS battery unit is connected, a system error will occur and the buzzer will sound, so please use caution.

The main features of the UPS option are:

- Long-lasting, maintenance-free rechargeable batteries
- Communication via integrated interfaces
- Temperature sensor
- Deep discharge protection

UPS Principle

With the optionally integrated UPS, the PS-B system completes write operations even after a power loss. When the UPS detects a power loss, it switches to battery operation immediately without interruption. This means that all running programs are ended properly by the UPS software. This prevents the possibility of inconsistent data.

NOTE:

- This function is only available if the UPS is configured and its driver is activated (see page 122).
- The monitor is not handled by the UPS and will shut off when the power fails.

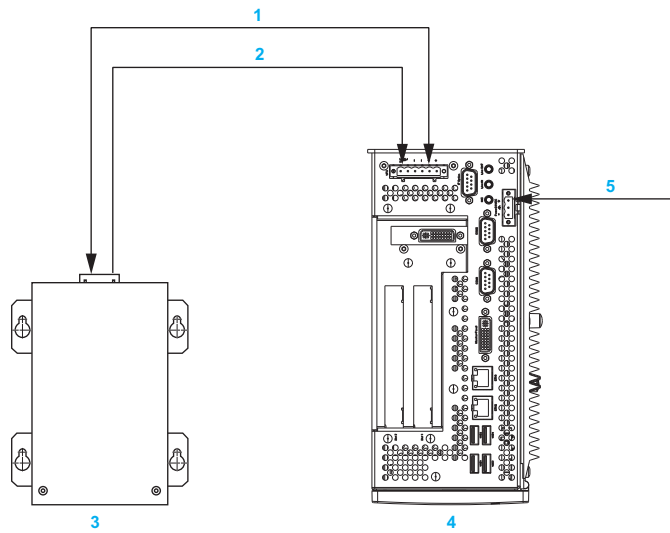

- 1 Battery / Load mode
- 2 Temperature
- 3 UPS battery unit
- 4 PS-B with integrated UPS module
- 5 Supply voltage +24 Vdc

Integrated UPS Module Description

The following table gives the technical data of the UPS module integrated in the PS-B with the UPS option:

Features	Values
Switching Threshold Mains / Battery Operation	15 / 13 V
Mains Failure Bridge-over Time	Max. 20 min at 150 W load
Charging Current	Max. 0.5 A
Deep Discharge Protection	At 10 V on the battery unit
Short Circuit Protection	No
Power Requirements	Max. 7.5 W
Status Indicators	Via the system monitor (<i>see page 118</i>)
Configuration	Via the system monitor settings (<i>see page 122</i>)

UPS Battery Unit Description

The UPS battery unit is subject to wear and should be replaced regularly (at least following the specified lifespan).

The following figure shows the connector of the UPS battery unit:

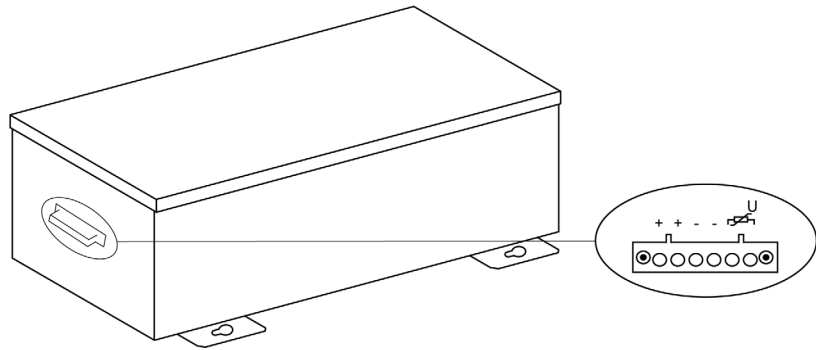

Features	Values
Battery: Type Method	Energys Cyclon 12 V 5 Ah (6 connected in series) Single cell (X cell)
Rated Voltage	12 V
Operating Current	Max. 8 A
Deep Discharge Voltage	10 V
Temperature Sensor	NTC resistance
Weight	Approx. 3.2 kg (7.05 lbs)
Ambient Temperature: Operation Storage Transport	– 40 to + 80 °C (– 40 °F to + 176 °F) – 65 to + 80 °C (– 85 °F to + 176 °F) – 65 to + 80 °C (– 85 °F to + 176 °F)
Relative Humidity: Operation Storage Transport	5...95%, non-condensing 5...95%, non-condensing 5...95%, non-condensing
Altitude	Max. 3000 meters (9843 feet)
Lifespan	10 years at 25 °C (77 °F) (up to 80% battery capacity)
Maintenance Interval (During Storage)	Charge once every 6 months
Battery Charging Time at Storage 0 %	15 hours

The following figure shows the dimensions of the UPS battery unit:

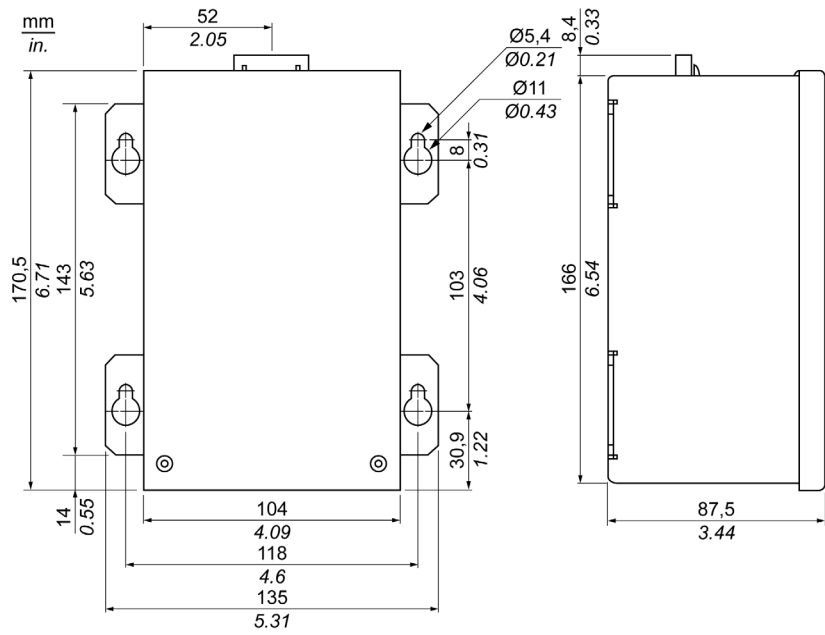

Years to 80% of battery capacity (guide of the battery lifespan when applying current)

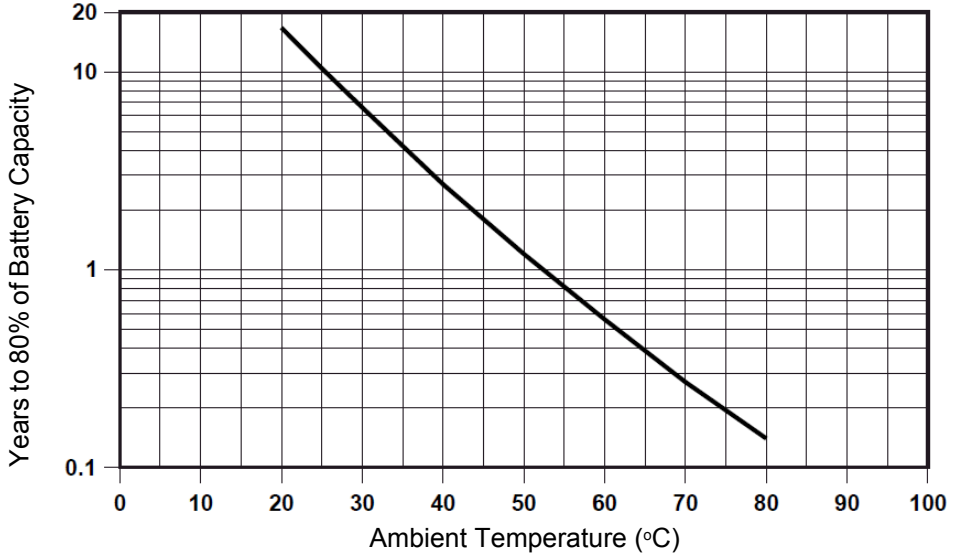

Diagrams of the Temperature and Lifespan to 20 % of Battery Capacity (guide of the battery lifespan when storing)

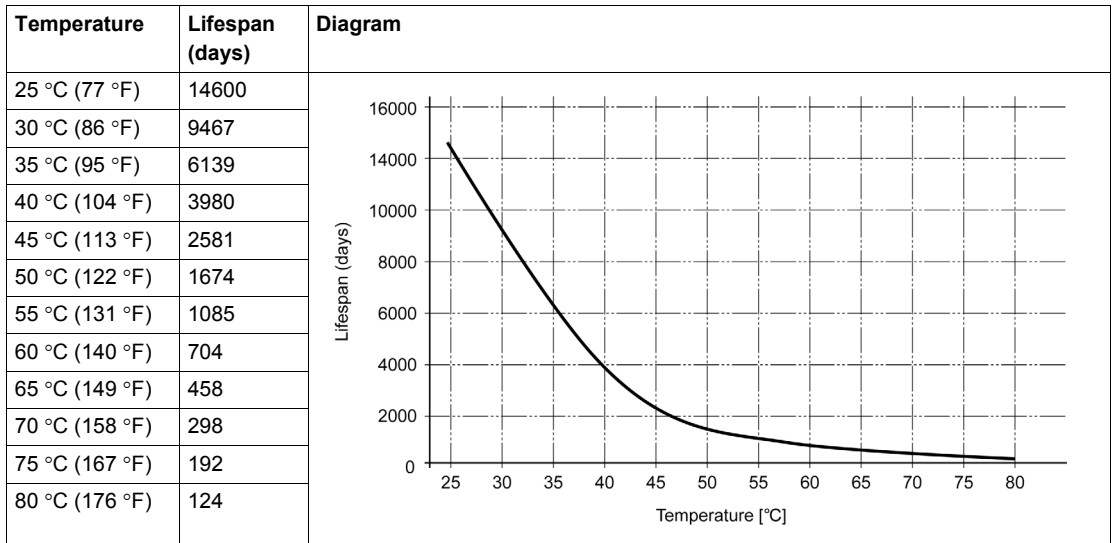

Deep Discharge Cycles

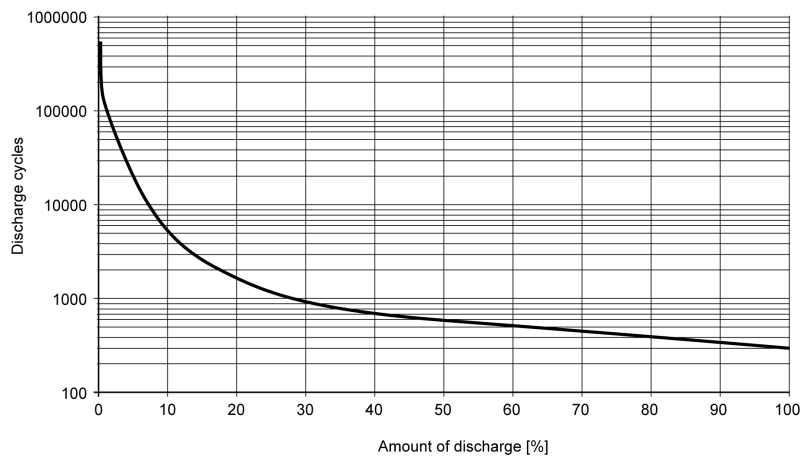

UPS Connection Cable

The UPS connection cable has two different shapes of 6-pin connectors to help prevent a cable connector from being inserted in the incorrect connector (UPS battery unit or PS-B side):



- 1 6-pin plug connector
- 2 6-pin socket connector

The following table gives the technical data for the UPS connection cable:

Features	Values
Length	3 m (9.843 ft)
Outer Diameter	8.5 mm ± 0.2 mm (0.33 in. ± 0.0078 in.)
Connector Type	6-pin plug connectors, tension clamp connection 6-pin socket connectors, tension clamp connection
Wire Cross Section Temperature Sensor Wire Voltage Wire	2 x 0.5 mm ² (AWG 20) 4 x 2.5 mm ² (AWG 13)
Line Resistance 0.5 mm ² 2.5 mm ²	Max. 39 Ω/km (63 Ω/mile) Max .7.98 Ω/km (13 Ω/mile)
Flex Radius Fixed Installation Free-moving	5 x wire cross-section 10 x wire cross-section
Temperature Range Operation Storage	- 5...+ 80 °C (23 ...176 °F) - 30...+ 80°C (- 22 ...176 °F)
Weight	Approx. 143 kg/km (230 kg/miles)

Features	Values
Materials	
Cable Shielding	Thermoplastic PVC-based material
Color	Window gray (similar to RAL 7040)
Peak Operating Voltage	12 Vdc
Testing AC Voltage	
Wire/wire	1500 V
Operating Voltage	Max. 300 V
Current Load	10 A at + 20 °C (10 A at + 68 °F)

Mounting Instructions

By integrating the charging circuit in the PS-B housing, installation is reduced to merely attaching the connection cable to the UPS battery unit mounted next to the PS-B.

Due to the construction of these batteries, you can store and operate the UPS battery unit in any position.

For mounting the UPS battery unit, use the following figure as the drilling template:

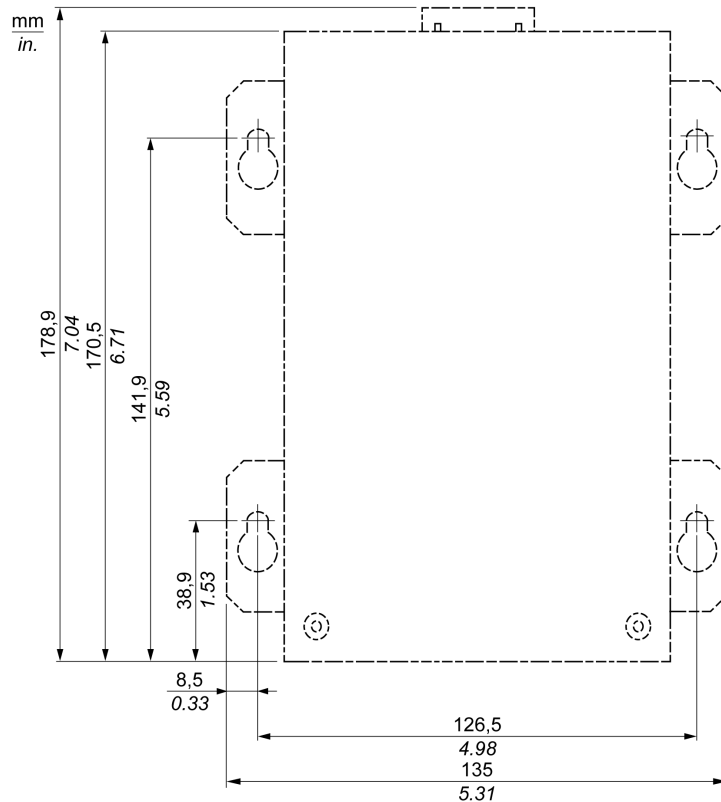

PCI / PCIe Card Installation

Overview

Before installing or removing a PCI / PCIe card, shut down Windows® in an orderly fashion and remove all power from the device.

DANGER

HAZARD OF ELECTRIC SHOCK, EXPLOSION OR ARC FLASH

- Remove all power from the device before removing any covers or elements of the system, and prior to installing or removing any accessories, hardware, or cables.
- Unplug the power cable from both the PS-B unit and the power supply.
- Always use a properly rated voltage sensing device to confirm power is off.
- Replace and secure all covers or elements of the system before applying power to the unit.
- Use only 24 Vdc when operating the PS-B unit.

Failure to follow these instructions will result in death or serious injury.

PCI / PCIe Cards with Cables

When using a PCI / PCIe card with an external cable attached, install a clamp or other device to secure the cable.

WARNING

EQUIPMENT DISCONNECTION OR UNINTENDED EQUIPMENT OPERATION

- Ensure that power, communication, and accessory connections do not place excessive stress on the ports. Consider the vibration environment when making this determination.
- Securely attach power, communication, and external accessory cables to the panel or cabinet.
- Use only commercially available USB cables.

Failure to follow these instructions can result in death, serious injury, or equipment damage.

PCI and PCIe Card Dimensions

Depending on the bus type, you can use standard PCI 2.2 half-size cards or PCI Express (PCIe) half-size cards.

NOTE: PCI or PCIe cards cannot exceed the following dimensions.

The following figure gives the dimensions of the standard half size PCI card:

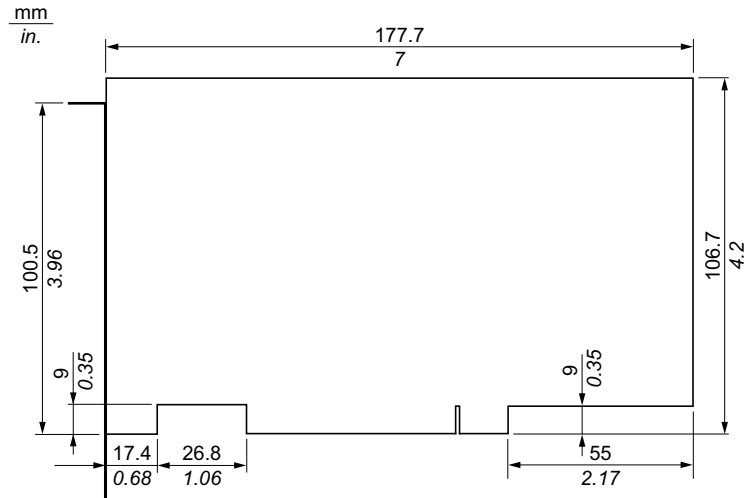

The following figure gives the dimensions of the standard half size PCIe card:

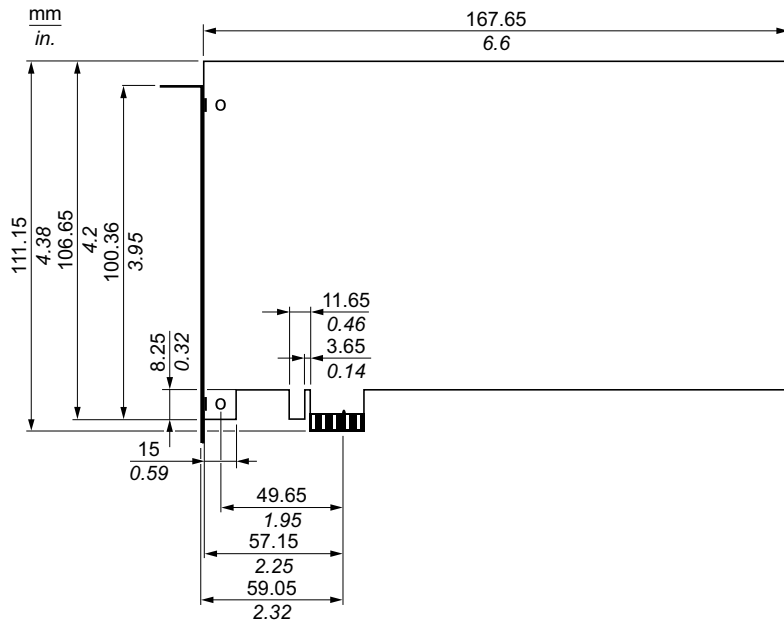

PCI Slot Position

The following figure shows the PCI slot position:

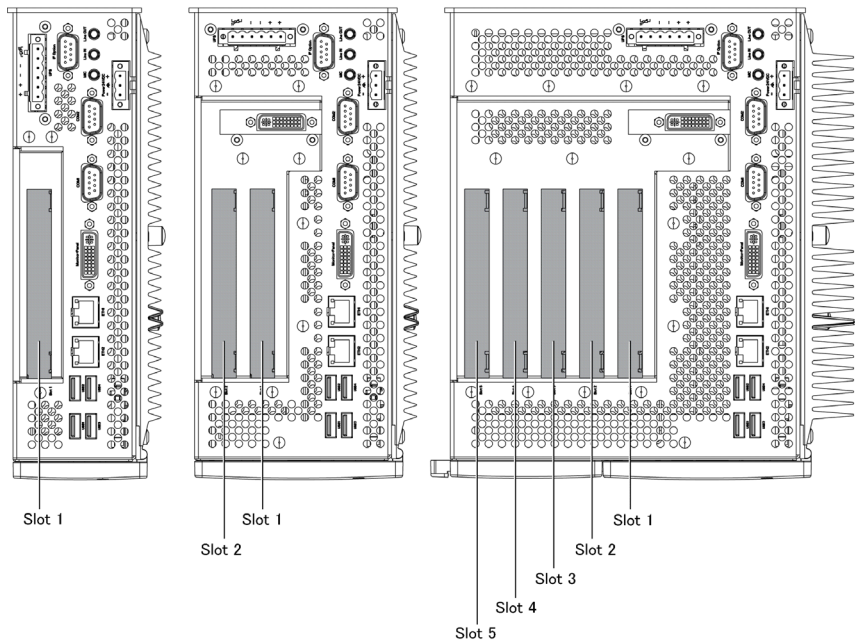

NOTE: Take into account the PCI/PCIe card type restriction according to the table below.

The following table provides an overview of the slots where inserting 64-bit cards is possible:

		Slot 1	Slot 2	Slot 3	Slot 4	Slot 5
1slot	1PCI	32-bit PCI	—	—	—	—
2slot	1PCI+1PCIe	32-bit or 64-bit PCI	PCIe	—	—	—
	2PCI	32-bit or 64-bit PCI	32-bit PCI	—	—	—
5slot	2PCI+3PCIe	32-bit or 64-bit PCI	32-bit or 64-bit PCI	PCIe	PCIe	PCIe
	4PCI+1PCIe	32-bit or 64-bit PCI	32-bit or 64-bit PCI	32-bit or 64-bit PCI	32-bit PCI	PCIe

PCI/PCIe Card Installation***NOTICE*****ELECTROSTATIC DISCHARGE**

Take the necessary protective measures against electrostatic discharge before attempting to remove the PS-B unit cover.

Failure to follow these instructions can result in equipment damage.

NOTE: Be sure to remove all power before attempting this procedure.

The table below describes how to install a PCI or PCIe card:

Step	Action
1	Disconnect the power cord to the PS-B unit.
2	Touch the housing or ground connection (not the power supply) to discharge any electrostatic charge from your body.

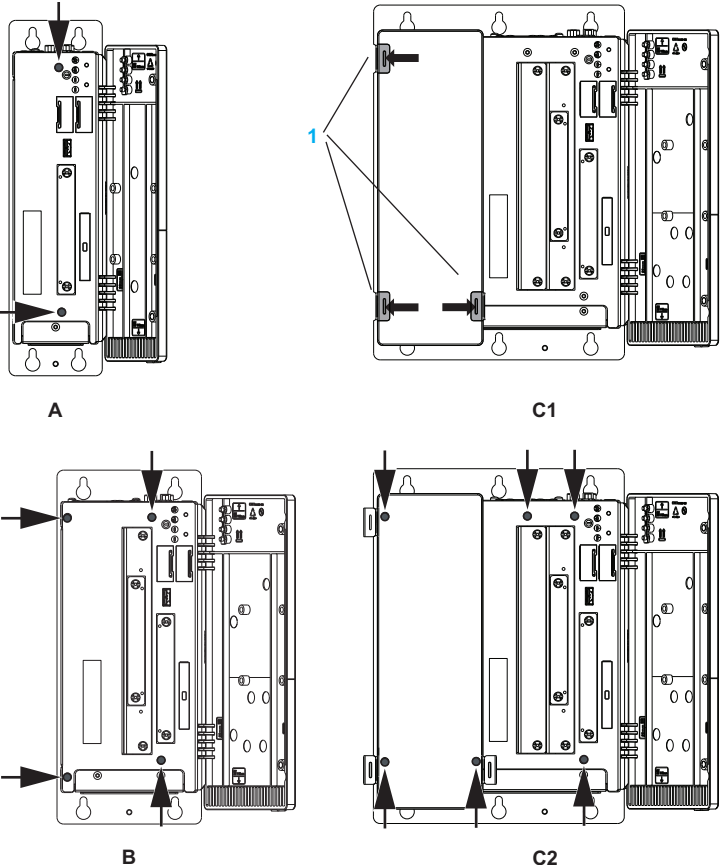
Step	Action
3	<p data-bbox="473 216 1116 241">Open the blue covers and remove the Torx screws of the PS-B unit:</p>  <p data-bbox="473 1149 1186 1304"> 1 Screw covers A 2 Torx screws (T10) for PS-B unit 1 slots B 4 Torx screws (T10) for PS-B unit 2 slots C1 Only for PS-B unit 5 slots, slide the screw covers with coins on the blue cover as shown before removing the Tork screws (C2). C2 6 Torx screws (T10) for PS-B unit 5 slots </p>
4	<p data-bbox="473 1317 1163 1367">Remove the side cover by sliding it towards the front. For PS-B unit 5 slots, remove the side cover by sliding it towards the left.</p>
5	<p data-bbox="473 1379 1218 1456">Unscrew the screw from the empty panel and remove the blank panel. Insert the PCI/PCIe board into the expansion board connector and secure in place using the filler panel screw.</p> <p data-bbox="473 1460 1218 1485">NOTE: The recommended torque to tighten these screws is 0.5 N•m (4.5 lb-in).</p>
6	<p data-bbox="473 1499 1094 1524">Replace the side cover and secure it by inserting the Torx screws.</p>
7	<p data-bbox="473 1535 1048 1561">For PS-B unit 5 slots, after Step 6, replace the screw covers.</p>

 CAUTION**OVERTORQUE AND LOOSE HARDWARE**

- Do not exert more than 0.5 N•m (4.5 lb-in) of torque when tightening the installation fastener, enclosure, accessory, or terminal block screws. Tightening the screws with excessive force can damage the plastic casing of the PS-B unit.
- When installing or removing screws, ensure that they do not fall inside the PS-B unit chassis.

Failure to follow these instructions can result in injury or equipment damage.

Compact Flash (CF) Card Installation and Removal

Preparing to use a CF Card

The PS-B unit operating system views the CF Card as a hard disk. Proper handling and care of the CF Card helps extend the life of the Card. Familiarize yourself with the Card prior to attempting insertion or removal of the Card.

DANGER

HAZARD OF ELECTRIC SHOCK, EXPLOSION OR ARC FLASH

- Remove all power from the device before removing any covers or elements of the system, and prior to installing or removing any accessories, hardware, or cables.
- Unplug the power cable from both the PS-B unit and the power supply.
- Always use a properly rated voltage sensing device to confirm power is off.
- Replace and secure all covers or elements of the system before applying power to the unit.
- Use only 24 Vdc when operating the PS-B unit.

Failure to follow these instructions will result in death or serious injury.

CAUTION

COMPACT FLASH CARD DAMAGE AND DATA LOSS

- Remove all power before making any contact with an installed CF Card.
- Use only CF Cards manufactured by Pro-face. The performance of the PS-B unit has not been tested using CF Cards from other manufacturers
- Confirm that the CF Card is correctly oriented before insertion.
- Do not bend, drop, or strike the CF Card.
- Do not touch the CF Card connectors.
- Do not disassemble or modify the CF Card.
- Keep the CF Card dry.

Failure to follow these instructions can result in injury or equipment damage.

Inserting the CF Card

The procedure below describes how to insert the CF Card.

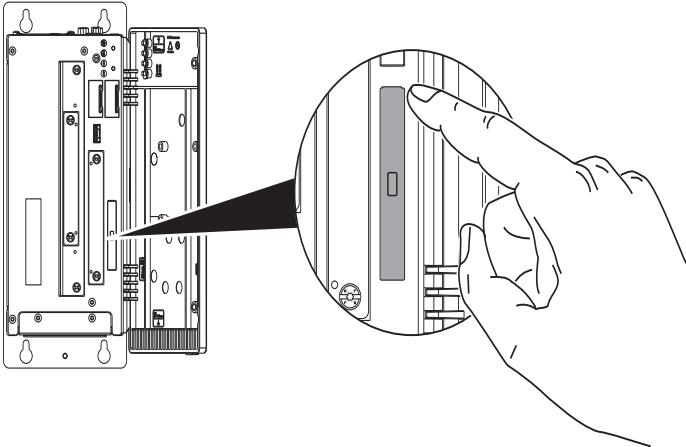
Step	Action
1	Shut down Windows® in an orderly fashion and remove all power from the device.
2	Remove the CF Card cover. 
3	Insert the CF Card firmly into the CF Card slot, and check that the eject button pops out.
4	Replace the CF Card cover.

Removing the CF Card

The procedure below describes how to remove the CF Card.

Step	Action
1	Shut down Windows® in an orderly fashion and remove all power from the device.
2	Remove the CF Card cover.
3	Press the eject button all the way to remove the CF Card from the CF Card slot. NOTE: The best way to do this is to use a pointed object such as a small screwdriver.
4	After inserting/removing the CF Card, replace the CF Card cover.

Data Writing Limitation

The CF Card is limited to approximately 100,000 write operations. Back up all CF Card data regularly to another storage media.

Fan Kit Installation

Overview

The fan kit (see page 135) is used in two purposes:

- for flat mounting of fanless PS-B or,
- replacement of PS-B with fan.

Before installing or replacing the fan kit remove all power from the device.

DANGER

HAZARD OF ELECTRIC SHOCK, EXPLOSION OR ARC FLASH

- Remove all power from the device before removing any covers or elements of the system, and prior to installing or removing any accessories, hardware, or cables.
- Unplug the power cable from both the PS-B and the power supply.
- Always use a properly rated voltage sensing device to confirm power is off.
- Replace and secure all covers or elements of the system before applying power to the unit.
- Use only 24 Vdc when operating the PS-B.

Failure to follow these instructions will result in death or serious injury.

Installing the Fan Kit

NOTICE

ELECTROSTATIC DISCHARGE

Take the necessary protective measures against electrostatic discharge before attempting to remove the PS-B unit cover.

Failure to follow these instructions can result in equipment damage.

The table below shows how to install the fan kit:

Step	Action
1	Disconnect the power cord to the PS-B unit.
2	Touch the housing or ground connection (not the power supply) to discharge any electrostatic charge from your body.

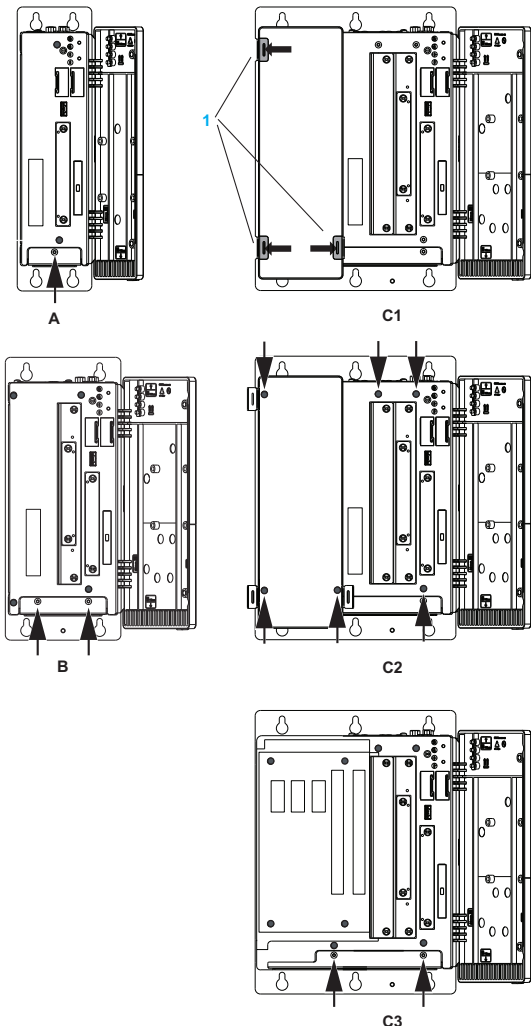
Step	Action
3	<p data-bbox="495 200 1140 227">Open the blue covers and remove the Torx screws of the PS-B unit:</p> <div data-bbox="632 272 1163 1290"></div> <p data-bbox="495 1306 664 1329">1 Screw covers</p> <p data-bbox="495 1333 923 1356">A 1 Torx screws (T10) for PS-B unit 1 slots</p> <p data-bbox="495 1360 923 1383">B 2 Torx screws (T10) for PS-B unit 2 slots</p> <p data-bbox="495 1387 1204 1435">C1 Only for PS-B unit 5 slots, slide the screw covers with coins on the blue cover as shown before removing the Tork screws (C2).</p> <p data-bbox="495 1439 923 1462">C2 6 Torx screws (T10) for PS-B unit 5 slots</p> <p data-bbox="495 1466 1233 1514">C3 Slide the side cover to the left to remove 2 Torx screws (T10) for PS-B unit 5 slots</p>
4	<p data-bbox="495 1528 989 1551">Remove the fan cover by sliding it towards the front.</p>

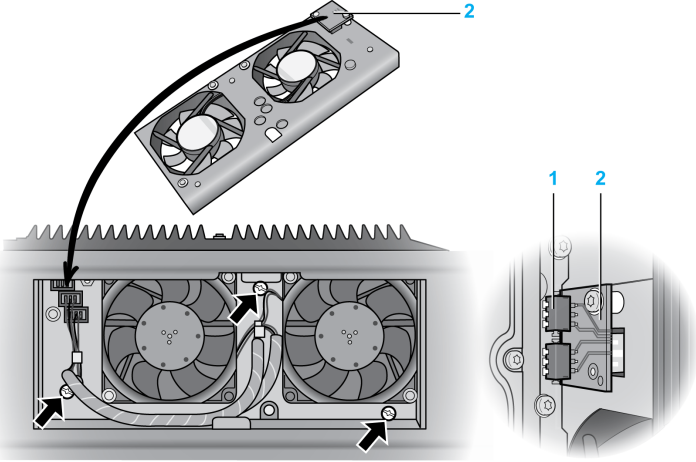
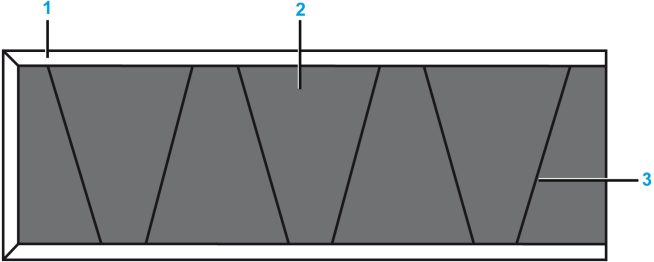
Step	Action
5	<p>Insert the frame as illustrated below and fasten the 1/4 turn screws:</p>  <p>1 Contact board (on the PS-B side) 2 Sliding contact (on the fan kit side)</p> <p>NOTE: Mount the contact board side to the sliding contacts on the system unit.</p>
6	<p>Place the dust filter in the fan cover and secure with the filter clasp.</p>  <p>1 Fan cover 2 Dust filter 3 Filter clasp</p>
7	<p>Place the fan cover in the housing and fasten using the Torx screws removed at step 2.</p> <p>NOTE: The recommended torque to tighten these screws is 0.5 N•m (4.5 lb-in).</p>

⚠ CAUTION

OVERTORQUE AND LOOSE HARDWARE

- Do not exert more than 0.5 N•m (4.5 lb-in) of torque when tightening the installation fastener, enclosure, accessory, or terminal block screws. Tightening the screws with excessive force can damage the plastic casing of the PS-B unit.
- When installing or removing screws, ensure that they do not fall inside the PS-B unit chassis.

Failure to follow these instructions can result in injury or equipment damage.

Installation

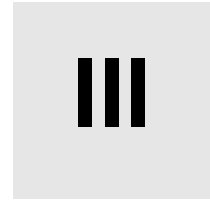

Subject of this Part

This part describes the product installation.

What's in this Part?

This part contains the following chapters:

Chapter	Chapter Name	Page
9	System Monitor	113
10	Maintenance	123

System Monitor



9

Subject of this Chapter

This chapter describes the system monitor features of the Industrial Personal Computer.

What's in this Chapter?

This chapter contains the following topics:

Topic	Page
System Monitor Interface	114
System Monitor Setting	120

System Monitor Interface

Overview

The System Monitor software enables you to monitor the following system parameters:

- **Temperature**
- **Fan**
- **SMART**
- **Battery**

Depending on the configuration (see page 120), if thresholds are exceeded the System Monitor Software alerts via a popup message (see page 118), sound, buzzer and an entry in the windows event log. You can configure (see page 122) a system shutdown when an alarm occurs.

Accessing the System Monitor

The procedure below shows how to access the System Monitor interface:

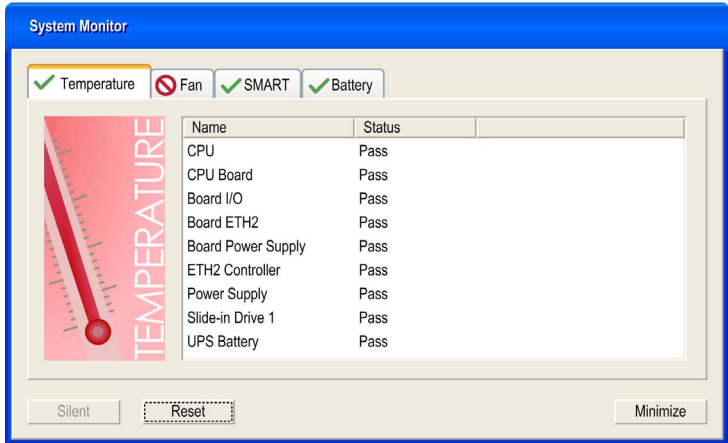
Step	Action
1	Start the Industrial Personal Computer operating system.
2	<p>In the task bar, double-click the following icon:</p>  <p>NOTE: If you cannot see the icon in the task bar, launch the System Monitor software by double-clicking the <i>SysMonGui.exe</i> file located in the following path: <i>C:\Utility\Systemon</i>.</p> <p>The following figure shows the System Monitor main window:</p> 

System Monitor Interface Description

The System Monitor interface shows all possible parameters and their actual status in system parameter tabs.

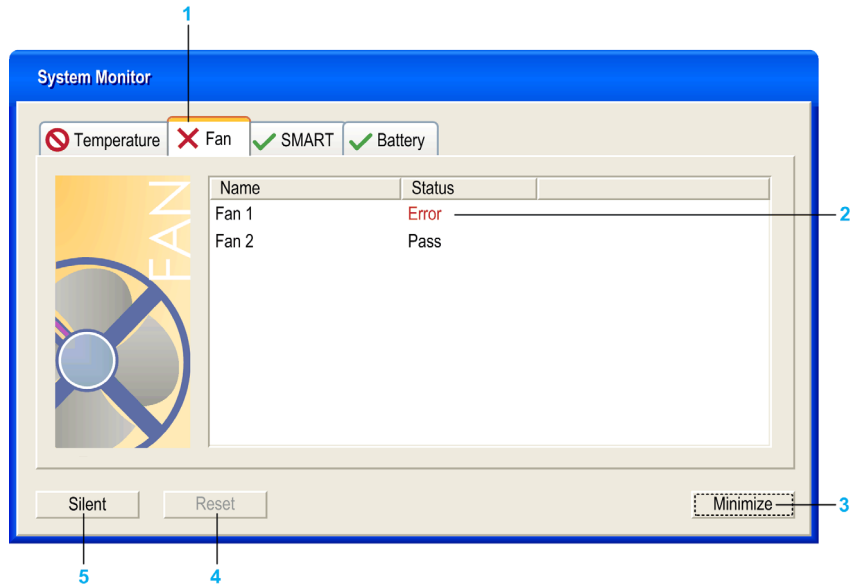

- 1 Icon specific tab (Refer to the table below).
- 2 Item name and status
- 3 Minimize the System Monitor to the system tray.
- 4 Resets alarmed item.
- 5 Disable buzzer and sound. Only active when sound or buzzer is playing.

The following table describes the icons of the system parameter tab:

Icon	Status	Meaning
✓	Ok	No alarm detected
⊘	Disabled	The system parameter is not monitored.
✗	Alarm	At least one detected alarm.

Temperature Status

The following figure shows the **Temperature** tab:

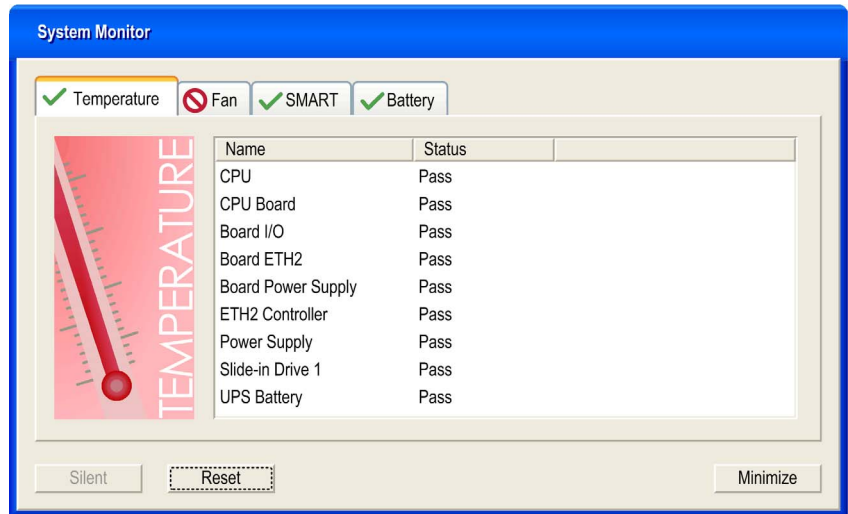

The following table describes the status messages of temperature parameters:

Status	Meaning
Pass	No alarm detected
Error	Alarm (limit exceeded)
Disabled	No alarm monitoring
***	Service is not running

Fan Status

The following figure shows the **Fan** tab:

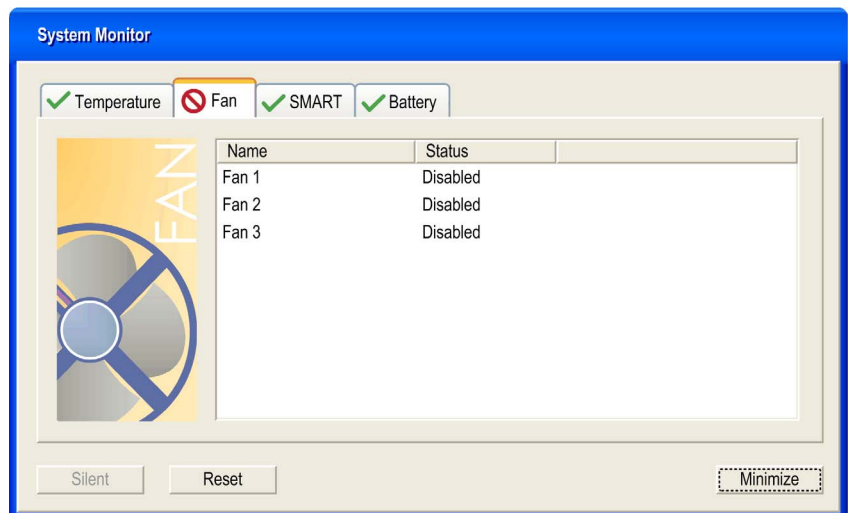

The following table describes the status messages of fan parameters:

Status	Meaning
Pass	No alarm detected
Error	Alarm (a fan does not function as expected)
Disabled	No alarm monitoring
***	Service is not running

SMART Status

The **SMART** status monitors the hard disk.

The following figure shows the **SMART** tab:

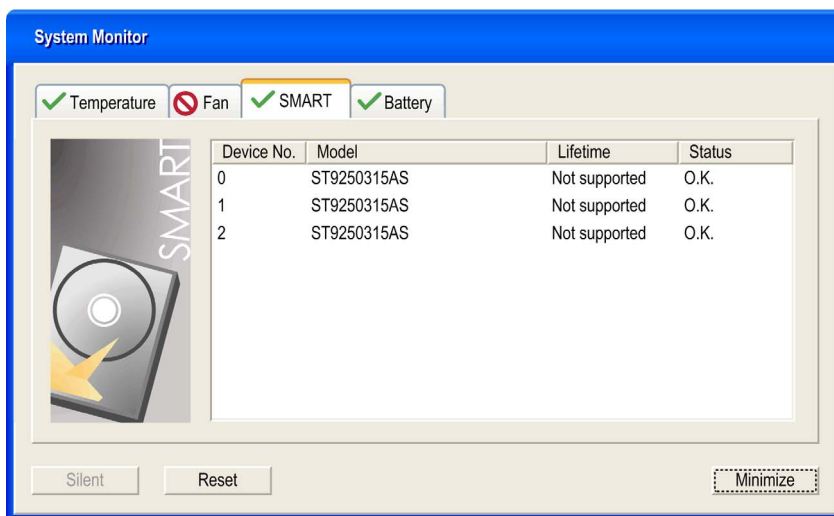

NOTE: In addition to the **Status** column, the **SMART** tab shows a column for the device lifetime. If the device has lifetime support, a **Lifetime** value in percent with a bar bargraph is displayed, otherwise **“Not supported”** is shown.

The following table describes the status message of the Industrial Personal Computer drives:

Status	Meaning
O.K.	No alarm detected
Alert	Failure reported by SMART or disk life-time reached
Disabled	No alarm monitoring
***	Service is not running

Battery Status

The following figure shows the **Battery** tab:

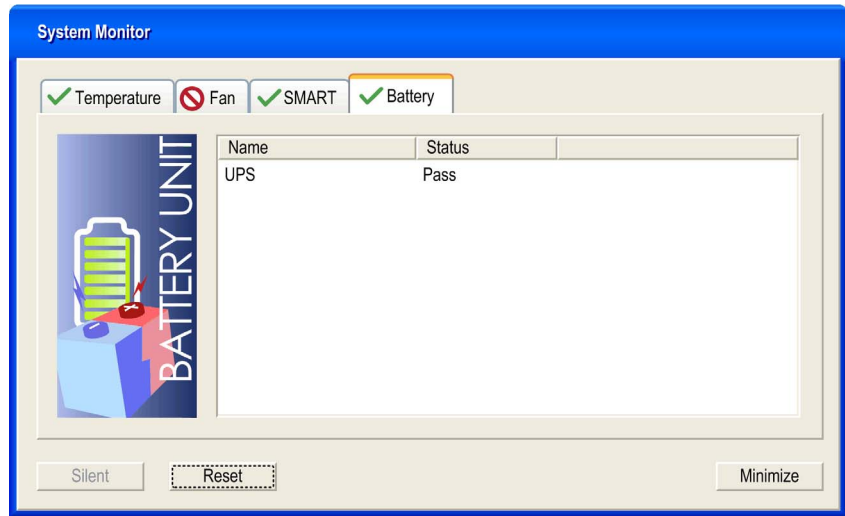

The following table describes the status message of the battery parameters:

Status	Meaning
Pass	No alarm detected.
Error	Battery unit detected a failure, e.g. battery is disconnected.
On Battery	Power failure - system is running on battery.
Low Battery	Battery level is critically low.
No Battery	No battery connected.
Low Battery Shutdown	Power failure - system is running on battery and battery level is critically low → system shutdown is initiated.
Disabled	No alarm monitoring.
***	Service is not running.

Popup Window Description

When an alarm is detected the following popup window is displayed:

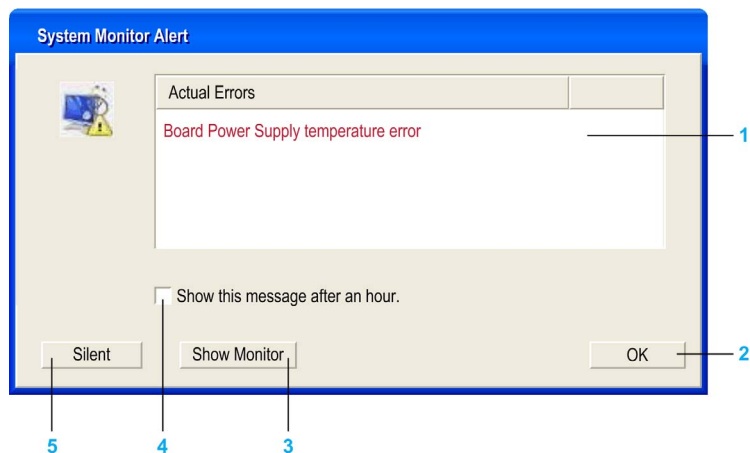

1 Shows the alarm or item that can be reset.

- 2 Closes the System Monitor Alert window.
- 3 Shows the main window.
- 4 If the check box is selected, closes the window for one hour even though the alarm is active. (A new alarm shows the window again).
- 5 Disable buzzer and sound. Only active when sound or buzzer is playing.

System Monitor Setting

Overview

You can set the System Monitor parameters and specify the type of alarm in the System Monitor applet in the Windows Control Panel.

Each system parameter has its own tab.

Use the following dialog box tabs to display the monitoring parameters and setup the various elements to monitor.

Temperature - System Monitor Properties

The screenshot below shows the **Temperature** tab:

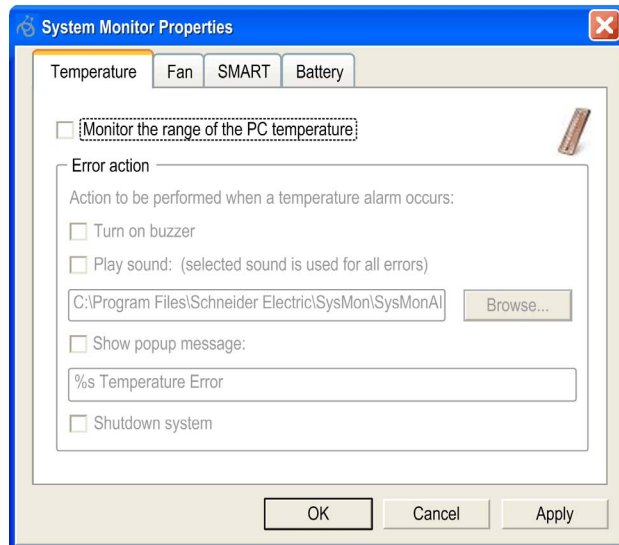

Field	Description
Monitor the range of the PC temperature	Select this check box to enable and begin monitoring the PC temperature. When enabled (see page 122), set the Error action .

Fan - System Monitor Properties

NOTE: Only available for Atom N270/Core 2 Duo P8400 Pre-installed Model.

The screenshot below shows the **Fan** tab:

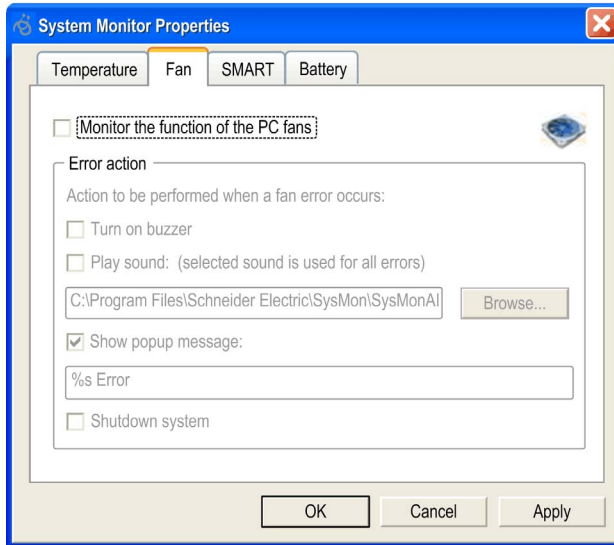

Field	Description
Monitor the function of the PC fans	Select this check box to enable and begin monitoring the function of fans. When enabled (see page 122), set the Error action .

SMART - System Monitor Properties

The screenshot below shows the **SMART** tab:

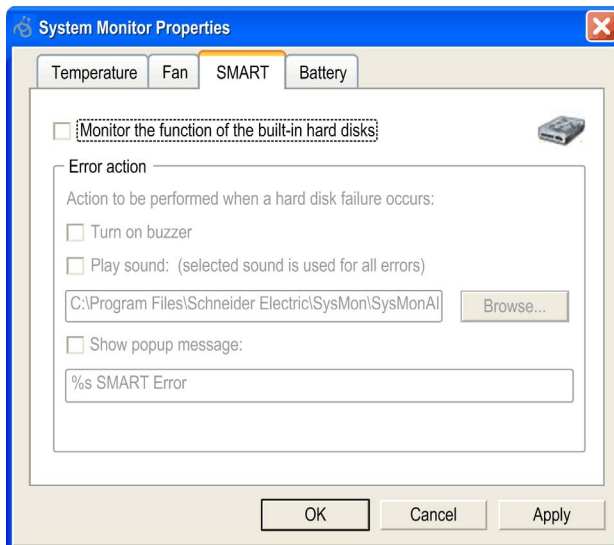

Field	Description
Monitor the function of the built-in hard disks	Select this check box to enable and begin monitoring the built-in hard disks. When enabled (see page 122), set the Error action .

Battery - System Monitor Properties

NOTE: Only available for Atom N270/Core 2 Duo P8400 Pre-installed Model DC Products.

The screenshot below shows the **Battery** tab:

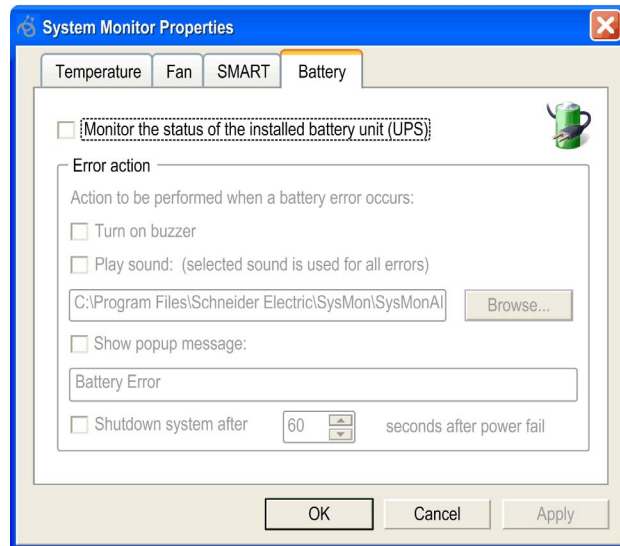

Field	Description
Monitor the status of the installed battery unit (UPS)	Select this check box to enable and begin monitoring the installed battery unit. When enabled (<i>see page 122</i>), set the Error action .

Error Action Configuration

Field	Description
Turn on buzzer	Select this check box to enable the buzzer.
Play sound	Select this check box to enable the sound that is used for all detected errors. Specify the sound file path (Browse... button).
Show popup message	When this check box is selected, status messages are displayed in the form of a popup.
Shutdown system	If you want the system to stop when an error is detected, select this check box. Not available in SMART tab.

Maintenance

10

Subject of this Chapter

This chapter covers maintenance of the PS-B unit

What's in this Chapter?

This chapter contains the following topics:

Topic	Page
Reinstallation Procedure	124
Regular Cleaning and Maintenance	125

Reinstallation Procedure

Introduction

In certain cases, it may be necessary to reinstall the operating system.

Precautions to be taken:

- Keep static-producing materials (plastic, upholstery, carpeting) out of the immediate work area.
- Do not remove ESD-sensitive components from their anti-static bags until you are ready to install them.
- When handling static-sensitive components, wear a properly grounded wrist strap (or equivalent).
- Avoid unnecessary contact with exposed conductors and component leads with skin or clothing.

Reinstallation

Refer to the relevant procedure in the included documentation "PS4000 Series Installation Guide".

Regular Cleaning and Maintenance

Introduction

Inspect the PS-B unit periodically to determine its general condition. For example:

Are all power cords and cables connected properly? Have any become loose?

Are all installation fasteners holding the unit securely?

Is the ambient temperature within the specified range?

Are there any scratches or traces of dirt on the installation gasket?

The following describes service/maintenance work which can be carried out by a trained, qualified user.

DANGER

HAZARD OF ELECTRIC SHOCK, EXPLOSION OR ARC FLASH

- Remove all power from the device before removing any covers or elements of the system, and prior to installing or removing any accessories, hardware, or cables.
- Unplug the power cable from both the PS-B unit and the power supply.
- Always use a properly rated voltage sensing device to confirm power is off.
- Replace and secure all covers or elements of the system before applying power to the unit.
- Use only 24 Vdc when operating the PS-B unit.

Failure to follow these instructions will result in death or serious injury.

DANGER

EXPLOSION HAZARD

- Always confirm the ANSI/ISA 12.12.01 and CSA C22.2 N°213 hazardous location rating of your device before installing or using it in a hazardous location.
- To power on or power off a PS-B unit installed in a Class I, Division 2 hazardous location, you must either:
 - Use a switch located outside the hazardous environment, or
 - Use a switch certified for Class I, Division 1 operation inside the hazardous area.
- Do not disconnect equipment unless power has been switched off or the area is known to be non-hazardous. This applies to all connections including power, ground, serial, parallel, and network connections.
- Never use unshielded / ungrounded cables in hazardous locations.
- Use only non-incendive USB configuration.
- When enclosed, keep enclosure doors and openings closed at all times to avoid the accumulation of foreign matter inside the workstation.

Failure to follow these instructions will result in death or serious injury.

⚠ WARNING**RISK OF BURNING INJURY**

During operation, surface temperatures of the heat sink may reach 70°C (158°F).
Do not touch the surface of the heat sink during operation.

Failure to follow these instructions can result in death, serious injury, or equipment damage.

Cleaning Solutions**⚠ CAUTION****HARMFUL CLEANING SOLUTIONS**

Do not clean the unit or any component of the unit with paint thinner, organic solvents, or strong acids.

Failure to follow these instructions can result in injury or equipment damage.

Lithium Battery

The PS-B unit contains one battery, which is needed for backing up the real-time clock (RTC).

NOTE: The following characteristics, features and limits only apply to this accessory and can deviate from those specified for the entire device. For the device where this accessory is installed, refer to the data provided specifically for the device.

Features	PFXZPSBTLT1 (CR2477N)
Capacity	950 mAh
Voltage	3 V
Self Discharge at 23°C(73.4 °F)	< 1% per year
Storage Time	Max. 3 years at 30°C (86°F)
Environmental Characteristics	
Storage Temperature	-20 ... +60°C (-4°F ... 140°F)
Relative Humidity	0 to 95% non-condensing

Replacing the Battery

DANGER

HAZARD OF ELECTRIC SHOCK, EXPLOSION, OR ARC FLASH

Read and understand the safety information in the Regular Cleaning and Maintenance section (see *page 125*) before attempting this procedure.

Failure to follow these instructions will result in death or serious injury.

DANGER

EXPLOSION, FIRE, OR CHEMICAL HAZARD

- Replace battery with identical type.
- Follow all battery manufacturer's instructions.
- Do not recharge, disassemble, heat above 100 °C (212 °F), or incinerate.
- Use your hands or insulated tools to remove or replace the battery.
- Maintain proper polarity when inserting and connecting a new battery.
- Remove all replaceable batteries before discarding the PS-B unit.
- Recycle or properly dispose of used batteries.

Failure to follow these instructions will result in death or serious injury.

NOTE:

- The product design allows you to change the battery with the PS-B unit either on or off. In some countries, safety regulations do not allow you to change batteries while the unit is on.
- Previous settings will be restored when changing the battery with the power turned off (as the settings are stored in non-volatile EEPROM). However, the date and time must be reset because this data is lost when changing the battery.
- Only qualified personnel can change the battery.

Procedure

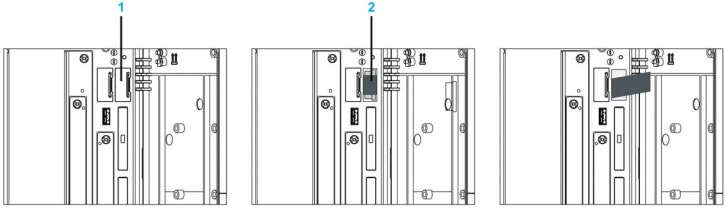
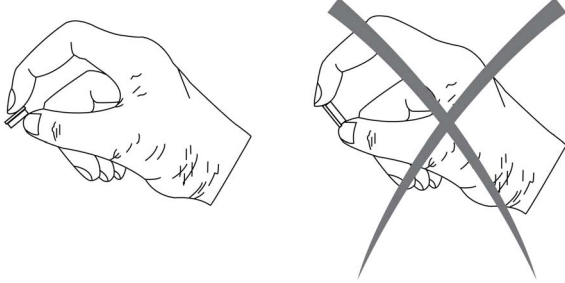
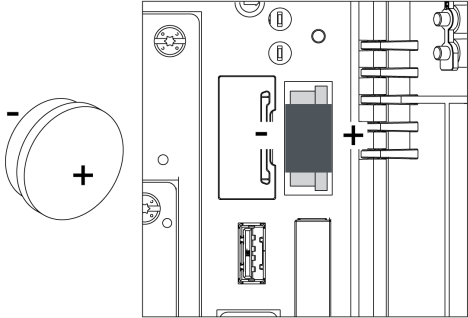
Step	Action
1	Disconnect the power supply to the PS-B unit.
2	Touch the housing or ground connection (not the power supply) to discharge any electrostatic charge from your body.
3	 <p>1 Remove the black plastic cover from the battery compartment. 2 Carefully pull out the battery using removal strips.</p>
4	<p>The battery should not be held by its edges. Insulated tweezers may also be used for inserting the battery.</p> 
5	<p>Insert the new battery with correct polarity.</p> 
6	To make the next battery change easier, be sure the removal strip is in place when inserting battery.
7	Reconnect the power supply to the PS-B unit (plug in power cable and press power button).
8	You may need to reset the date and time in the BIOS settings.

NOTE: Replacement of the battery in the PS-B unit other than with the type specified in this documentation may present a risk of fire or explosion.

⚠ WARNING

IMPROPER BATTERY CAN PROVOKE FIRE OR EXPLOSION

Replace battery only with identical type: Type CR2477N.

Failure to follow these instructions can result in death, serious injury, or equipment damage.

Replacing the Fan Filter

⚠ DANGER

HAZARD OF ELECTRIC SHOCK, EXPLOSION, OR ARC FLASH

Read and understand the safety information in the Regular Cleaning and Maintenance section (see page 125) before attempting this procedure.

Failure to follow these instructions will result in death or serious injury.

The fan filters are subject to wear, and should be checked with appropriate frequency to determine whether the air flow provides sufficient cooling. An exchange or cleaning of the filter kit is appropriate at that time.

The table below shows how to replace the fan filter:

Step	Action
1	Disconnect the power cord to the PS-B unit.
2	Touch the housing or ground connection (not the power supply) to discharge any electrostatic charge from your body.

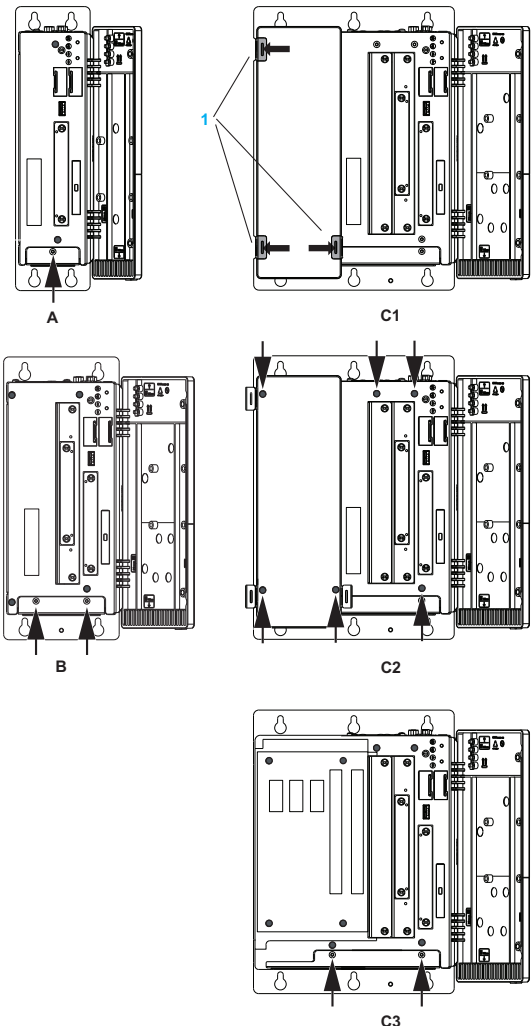
Step	Action
3	<p data-bbox="495 200 1140 227">Open the blue covers and remove the Torx screws of the PS-B unit:</p> <div data-bbox="622 239 1153 1257"></div> <p data-bbox="495 1267 1212 1474">1 Screw covers A 1 Torx screws (T10) for PS-B unit 1 slots B 2 Torx screws (T10) for PS-B unit 2 slots C1 Only for PS-B unit 5 slots, slide the screw covers with coins on the blue cover as shown before removing the Torx screws (C2). C2 6 Torx screws (T10) for PS-B unit 5 slots C3 Slide the side cover to the left to remove 2 Torx screws (T10) for PS-B unit 5 slots</p>
4	Remove the fan cover by sliding it towards the front.

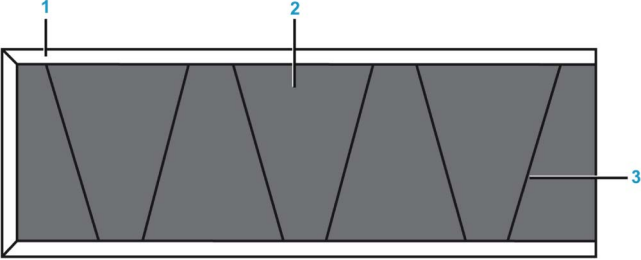
Step	Action
5	<p>Replace the fan filter in the fan cover and secure with the filter clasp.</p>  <p>1 Fan cover 2 Fan filter 3 Filter clasp</p>
6	<p>Place the fan cover in the housing and fasten using the screws removed at step 3.</p> <p>NOTE: The recommended torque to tighten these screws is 0.5 N•m (4.5 lb-in).</p>

⚠ CAUTION

OVERTORQUE AND LOOSE HARDWARE

- Do not exert more than 0.5 N•m (4.5 lb-in) of torque when tightening the installation fastener, enclosure, accessory, or terminal block screws. Tightening the screws with excessive force can damage the plastic casing of the PS-B unit.
- When installing or removing screws, ensure that they do not fall inside the PS-B unit chassis.

Failure to follow these instructions can result in injury or equipment damage.

Replacing the Fan Kit

The fan kit help keep the PS-B from overheating. If necessary to replace the fan kit (see page 135), follow the fan kit installation procedure (see page 107) to perform this task.

Appendices

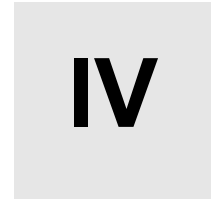

What's in this Part?

This part contains the following chapters:

Chapter	Chapter Name	Page
11	Accessories	135
12	After-sales service	137

Accessories

11

Accessories for the PS-B unit

Available Accessories

Accessories are available as options. The list of accessories available for the PS-B unit is shown below:

Description	Reference
CF Card, 4GB	PFXZCBCF41
CF Card, 8GB	PFXZCBCF81
HDD Unit without OS, 250GB (for Slide in Disk)	PFXZPSSCHDD251
HDD Unit without OS, 500GB (for Slide in Disk)	PFXZPSSCHDD501
SSD Unit without OS, 32GB (for Slide in Disk)	PFXZPSSCSSD321
SSD Unit without OS, 60GB (for Slide in Disk)	PFXZPSSCSSD601
Adaptor to install an unit for Slide in Disk to Slide in Slot	PFXZPSSSAD1
DVD multi drive (for Slide in Slot)	PFXZPSSSMD1
A cable converting DVI-I to RGB	CA7-CBLCVRGB-01
Analog RGB Interface cable used to send the image signal to the monitor (corresponding to Analog line) from the host. (Dsub15 pin Plug) (4.5m)	FP-CV02-45
Digital Visual Interface cable used to send the image signal to the monitor (corresponding to Digital line) ^{*1} from the host. (DVI-D 24-pin male) (5 m)	FP-DV01-50
A branch cable converting DVI-I to DVI-D/RGB	CA7-CBLCVDVI-D/RGB-01
USB interface cable (5m) used for touch panel data transmission between the host and the FP. The cable type is A-B.	FP-US00
Extension cable attaching USB port to front panel.	CA5-USBEXT-01
Serial interface cable (5m) used for touch panel data transmission between the host and the FP. This is a straight Dsub9 pin female cable and should be connected with COM1 or COM2.	FP61V-IS00-O
Maintenance Items	
DC power supply connector (Screw type 5pcs)	PFXZPSCNDC1
Lithium battery for replacement (for BIOS backup)	PFXZPSBTLT1
Replacement FAN filter for PS4000 Series BOX type with 1 Slot (5 pcs=5 sets)	PFXZPB1FTFAN1
Replacement FAN filter for PS4000 Series BOX type with 2 Slots (5 pcs=5 sets)	PFXZPB2FTFAN1
Replacement FAN filter for PS4000 Series BOX type with 5 Slots (5pcs)	PFXZPB5FTFAN1

Description	Reference
Replacement FAN kit for PS4000 Series BOX type with 1 Slot (for 1 set)	PFXZPB1IUFAN1
Replacement FAN kit for PS4000 Series BOX type with 2 Slot (for 1 set)	PFXZPB2IUFAN1
Replacement FAN kit for PS4000 Series BOX type with 5 Slot (for 1 set)	PFXZPB5IUFAN1
Noise Filter for Marine Certification *2	PFXZFTPND1
UPS battery unit	PFXZPSEUUPB1
UPS connection cable between UPS interface board and UPS battery unit (3m)	PFXZPSCBUP3

*1For Pro-face's FP Series connection to the host using Digital line, refer to the manual for FP Series.

*2The HDD-less DC powered type of the fan-less (Atom N270 embedded) model is GL certified only when connected to a Noise Filter for Marine Certification.

After-sales service

12

For details on after-sales service, refer to Pro-face website at
<http://www.pro-face.com/trans/en/manual/1001.html>

