

PL3000 Series Hardware Manual



Preface

Thank you for purchasing Pro-face's PL3000 Series Graphic Logic Controller Interface (Hereafter referred to as the "PL unit").

Before operating your PL unit, be sure to read this manual to familiarize yourself with the PL unit's operation procedures and features.

NOTICE

1. Copying this manual's contents, either in whole or in part, is prohibited without the express permission of Digital Electronics Corporation, Japan.
2. The information contained in this manual is subject to change without notice.
3. Should you find any errors or omissions in this document, please contact Digital Electronics Corporation to report your findings.
4. Regardless of Clause 3 above, Digital Electronics Corporation shall not be held responsible for any damages, losses or third-party damages resulting from the use of this product.

© 2007 Copyright Digital Electronics Corporation. All rights reserved.

Product names used in this manual are the trademarks / registered trademarks of their respective owners.

Essential Safety Precautions

All safety-related procedures stated in this document must be followed to operate the PL correctly and safely. Be sure to read this and any related documents thoroughly to understand the correct operation and functions of the PL unit.





IMPORTANT

- For the Built-in Battery Unit version, see "7.2.1 Caution (page 7-7)".

For detailed instruction of how to use the keypad, refer to PL3000 Series Reference Manual.



Safety Icons

Throughout this manual, these icons provide essential safety information for PL operation procedures requiring special attention. These icons indicate the following levels of danger:

 DANGER	Indicates situations where severe bodily injury, death or major equipment damage occur.
 WARNING	Indicates situations where death, severe injury, or major equipment damage can occur.
 CAUTION	Indicates situations where slight injury or minor equipment damage can occur.
	Indicates actions or procedures that should NOT be performed.
	Indicates actions or procedures that MUST be performed to ensure correct unit operation.

WARNING

System Design

-  Do not create PL touch panel switches that could possibly endanger the safety of personnel or equipment. A malfunction of the PL unit, its I/O unit(s), cable(s), or other related equipment can cause unexpected output signals, leading to a serious accident. Be sure to design all important machine operation switches so they are operated via a separate control system, and not via the PL.
-  Do not create PL touch panel switches to control machine safety operations, such as an emergency stop switch. Install these switches as separate hardware switches, otherwise severe bodily injury or equipment damage can occur.
-  Be sure to design your system so that a communication fault between the PL and its host controller will not cause equipment to malfunction. This is to prevent any possibility of injury or equipment damage.

- ⊘ Do not use the PL as a warning device for critical alarms that can cause serious operator injury, machine damage or can halt system operation. Critical alarm indicators and their control/activator units must be designed using stand-alone hardware with redundancy and/or mechanical interlocks.
- ⊘ Do not use the PL with aircraft control devices, aerospace equipment, central trunk data transmission (communication) devices, nuclear power control devices, or medical life support equipment, due to these devices' inherent requirements of extremely high levels of safety and reliability.
- ⚠ When using the PL with transportation vehicles (trains, cars, and ships), disaster and crime prevention devices, various types of safety equipment, and medical devices that are not life-support related, use redundant and/or failsafe system designs to ensure proper reliability and safety.
- ⊘ After the PL unit's backlight burns out the touch panel is still active, unlike the PL unit's "Standby Mode". If the operator fails to notice that the backlight is burned out and touches the panel, a potentially dangerous machine operation error can occur. Therefore, do not create PL unit touch panel switches that may cause injury and/or equipment damage. If your PL unit's backlight suddenly turns OFF, use the following steps to determine if the backlight is actually burned out.
 - 1) If the PL unit's "Backlight Control" is not set and the screen has gone blank, your backlight is burned out.
 - 2) If the PL unit's "Backlight Control" is set to Standby Mode and the screen has gone blank, and touching the screen or performing another input operation does not cause the display to reappear, your backlight is burned out.

Handling

- ⊘ Do not disassemble or modify the PL unit. Doing so may cause a fire or an electric shock.
- ⊘ Do not operate the PL in an environment where flammable gases are present, since it may cause an explosion.

Wiring

- ⚠ To prevent electrical shock or equipment damage, unplug the PL unit's power cord from the power supply prior to installing or wiring the PL.
- ⊘ Do not use any voltages not specified in the manual. Doing so may cause a fire or an electric shock.

Maintenance



- ⊘ Do not connect or disconnect Host and PL unit communication cables while the PL is turned ON.
- ⊘ The PL uses a lithium battery for backing up its internal clock data. The battery may explode if it is replaced incorrectly. When replacement is required, use a Pro-face-designated replacement product.
SEE 6.5 Replacing the Internal Battery (page 6-16)

CAUTION

Installation

-  Be sure all cable connectors are securely attached to the PL unit. A loose connection may cause incorrect input or output signals.

Wiring

-  Be sure to ground the PL unit's FG wire separately from other equipment FG lines. Also, be sure to use a grounding resistance of 100Ω or less and a 2mm^2 or thicker wire, or your country's applicable standard. Otherwise, electric shock or malfunctions may result.
-  Be sure to use only the designated torque to tighten the PL unit's terminal block screws. If these screws are not tightened firmly, it may cause a short-circuit, fire or incorrect unit operation.
-  Be sure that metal particles and wiring debris do not fall inside the PL unit. They can cause a fire, malfunction or incorrect unit operation.





Maintenance

-  Do not reset or turn the PL OFF or insert or remove the CF Card while the PL unit's CF Card or hard disk is being accessed. Otherwise, the CF Card and the hard disk internal data may be damaged or lost.

Unit Disposal

-  When the product is disposed of, it should be disposed of in a manner appropriate to, and in accordance with, the user country's industrial machinery disposal/recycling standards.

General Safety Precautions

-  Do not press on the PL unit's display with excessive force or with a hard object, since it can damage the display. Also, do not press on the touch panel with a pointed object, such as the tip of a mechanical pencil or a screwdriver, since doing so can damage the touch panel.
-  Do not install the PL where the ambient temperature exceeds the specified range. Doing so may cause a unit malfunction.
-  To prevent abnormally high temperatures from occurring inside the PL, do not restrict or block the PL unit's rear-face ventilation slots.
-  Do not operate the PL in areas where large, sudden temperature changes can occur. These changes can cause condensation to form inside the PL, possibly causing it to malfunction.
-  Do not allow water, liquids or metal fragments to enter inside the PL unit's case, since they can cause either a malfunction or an electric shock. The allowable pollution degree is 2.

- ⊘ Do not operate or store the PL in locations where it can be exposed to direct sunlight, high temperatures, excessive dust, moisture or vibration.
- ⊘ Do not operate or store the PL where chemicals evaporate, or where chemicals are present in the air.
Corrosive chemicals: Acids, alkalines, liquids containing salt
Flammable chemicals: Organic Solvents
- ⊘ Do not use paint thinner or organic solvents to remove dirt or oil from the PL unit's surface. Instead, use a soft cloth moistened with a diluted neutral detergent.
- ⊘ Do not use or store the PL in areas with direct sunlight, since the sun's ultraviolet rays may cause the LCD's quality to deteriorate.
- ⚠ Do not store the PL in an area where the temperature is lower than that recommended in the PL unit's specifications. Doing so may cause the LCD display's liquid to congeal, which can damage the LCD.

Also, if the storage area's temperature becomes higher than the specified level, the LCD's liquid may become isotropic, causing irreversible damage to the LCD. Therefore, only store the PL in areas where temperatures are within the PL unit's specifications.
- ⚠ After turning OFF the PL, be sure to wait a few seconds before turning it ON again. The PL may not operate correctly if it is restarted too quickly.
- ⚠ Due to the possibility of unexpected accidents, be sure to back up the PL unit's data regularly.



LCD Panel Usage Precautions

- The LCD panel's liquid contains an irritant. If the panel is damaged and any of this liquid contacts your skin, immediately rinse the area with running water for at least 15 minutes. If the liquid gets in your eyes, immediately rinse your eyes with running water for at least 15 minutes and consult a doctor.
- The PL unit's LCD screen may flicker or show unevenness in the brightness of certain images or at some contrast settings. This is an LCD characteristics and not a product defect.
- There's an individual difference in brightness and tone of LCD screen. Please be aware of this difference before using the lined-up plural units.
- Depending on the ambient temperature, LCD displays may sometimes look whitish (at high temperatures) or blackish (at low temperatures). This is an LCD characteristic and not a product defect.
- Some of PL unit's LCD screens may contain black and white colored pixels. This is an LCD characteristic and not a product defect.
- Extended shadows, or "Crosstalk" may appear on the sides of screen images. This is an LCD characteristic and not a product defect.
- The color displayed on the PL unit's LCD screen may appear different when seen from outside the specified viewing angle. This is an LCD characteristic and not a product defect.

- When the same image is displayed on the PL unit's screen for a long period, an afterimage may appear when the image is changed. This is an LCD characteristic and not a product defect.
- To prevent an afterimage:
 - * Set the PL unit's display OFF feature when you plan to display the same screen image for a long period of time.
 - * Change the screen image periodically and try to not display the same image for a long period of time.

Information Symbols

This manual uses the following icons:

	Indicates a warning or a product limitation. Be sure to follow the instructions given with this icon to ensure the safe operation of the PL.
*	Indicates useful or important supplemental information.
	Contains additional or useful information.
	Indicates pages containing related information.

About the Manuals

For the detailed information on PL series, refer to the following manuals.

- PL3000 Series Hardware Manual
- PL3000 Series Reference Manual
- PL3000 Series API Reference Manual
- Installation Guides for various optional items



- PL specifications may change when optional items are used. Check the optional item installation guides' specifications for variances, if any.

The manuals can be downloaded from Pro-face website.

URL

<http://www.pro-face.com/otasuke/>

PL3000 Series Model Name Indication

Model name

APL3*00-* *
a b c

a	0	No display
	6	12.1-inch display: SVGA (800 x 600 dots)
	7	15-inch display: XGA (1024 x 768 dots)
	9	19-inch display: SXGA (1280 x 1024 dots)
b	B	Box type built-in computer
	T	TFT type
	K	Keypad type
c	A	AC type power supply is used.
	D	DC type power supply is used.

PL3000 Series Model Names

The term “PL3000” Series refers to the following numbers:

Series	Models	Type	
PL3000 Series	PL-3000B Series	APL3000-BA	Box type built-in computer (Control box)
		APL3000-BD	
	PL-3600T Series	APL3600-TA	12.1-inch panel computer
		APL3600-TD	
	PL-3600K Series	APL3600-KA	12.1-inch panel computer with keypad
		APL3600-KD	
	PL-3700T Series	APL3700-TA	15-inch panel computer
		APL3700-TD	
	PL-3700K Series	APL3700-KA	15-inch panel computer with keypad
		APL3700-KD	
	PL-3900T Series	APL3900-TA	19-inch panel computer
		APL3900-TD	

The panel computer consists of the box-type built-in computer (control box) and the front module.

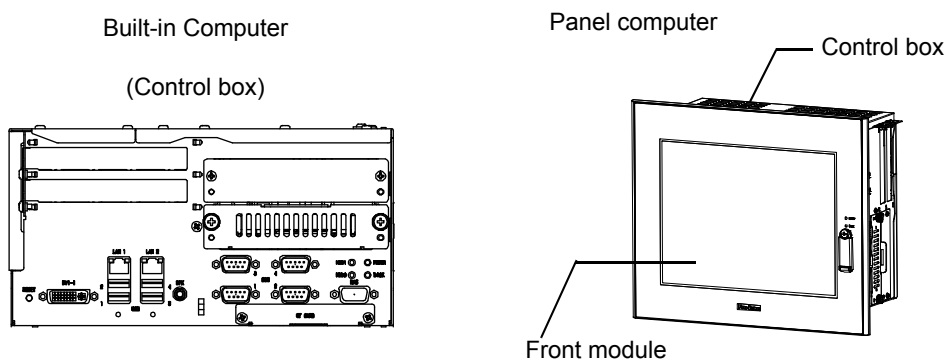

The combination of the control box and the front module for each model is described as shown below.

Series	Models	Control box Model No.	Front module Model No.	
PL3000 Series	PL-3000B Series	APL3000-BA	—	
		APL3000-BD	—	
	PL-3600T Series	APL3600-TA	APL3000-BA	APL3600-TFM-BLD
		APL3600-TD	APL3000-BD	
	PL-3600K Series	APL3600-KA	APL3000-BA	APL3600-KFM-BLD
		APL3600-KD	APL3000-BD	
	PL-3700T Series	APL3700-TA	APL3000-BA	APL3700-TFM-BLD
		APL3700-TD	APL3000-BD	
	PL-3700K Series	APL3700-KA	APL3000-BA	APL3700-KFM-BLD
		APL3700-KD	APL3000-BD	
	PL-3900T Series	APL3900-TA	APL3000-BA	APL3600-TFM-BLD
		APL3900-TD	APL3000-BD	

Package Contents

■ Package contents of the PL-3000B Series (control box)

The following items are included in the PL unit's package. Before using the PL, please check that all items listed here are present.

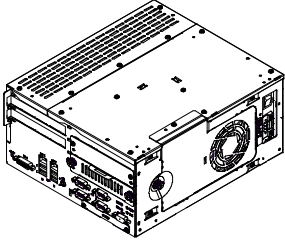
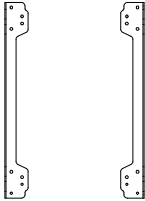
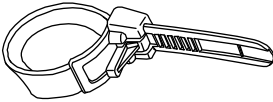
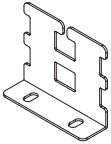
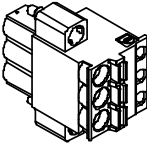
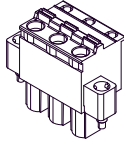
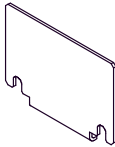
<p>PL Unit: 1</p> 	<ul style="list-style-type: none"> • English and Japanese Installation Guides (one of each) • Warning/Caution Information (1) 	<p>Installation Fasteners Set: 1 (Fasteners: 2, screws: 4)</p> 	
<p>USB Cable Clamp: (2ports) 2</p> 	<p>USB Holder Set: 1 (Fasteners: 1, screws: 2)</p> 		
<p>Power Connector: 1</p> <p>AC type (5.08mm [0.20in.] pitch)</p> 			<p>DC type (7.62mm [0.30in.] pitch)</p> 
<p>Power Switch Cover: 1 (AC type only) (cover: 1, screws: 2) *1</p> 			

*1 The Power Switch Cover is packed in the PL unit approved ANSI/ISA standards, showing the appropriate revision code on the PL unit. Please see " Installation prerequisites for standards (page 13)".

IMPORTANT

- When installing the PL, be careful not to damage the built-in HDD.



NOTE

- If your PL unit contains a built-in accessory, that accessory's Installation Guide will also be included in the PL's packing box. Please check that all items normally included with that accessory are also included in this box.

This unit has been carefully packed, with special attention to quality. However, should you find anything damaged or missing, please contact your local PL distributor immediately.

■ Package contents of the PL-3600*/3700*/3900T Series

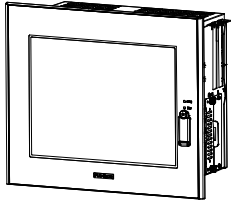
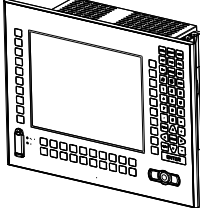
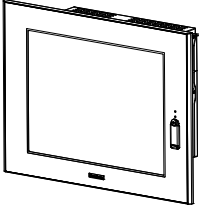
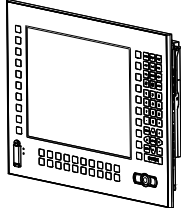
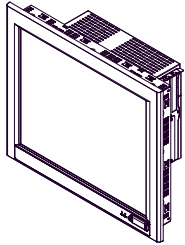
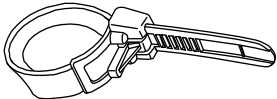
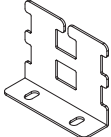
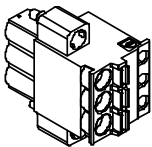
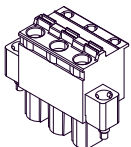
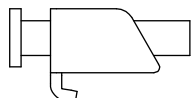
The following items are included in the PL unit's package. Before using the PL, please check that all items listed here are present.

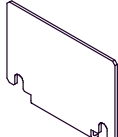
<p>PL Unit: 1 One of the following units: PL-3600T Series, PL-3600K Series, PL-3700T Series, PL-3700K Series, PL-3900T Series</p> <div style="display: flex; justify-content: space-around; align-items: center;"> <div style="text-align: center;">  <p>PL-3600T Series</p> </div> <div style="text-align: center;">  <p>PL-3600K Series</p> </div> </div> <div style="display: flex; justify-content: space-around; align-items: center; margin-top: 20px;"> <div style="text-align: center;">  <p>PL-3700T Series</p> </div> <div style="text-align: center;">  <p>PL-3700K Series</p> </div> <div style="text-align: center;">  <p>PL-3900T Series</p> </div> </div>	
<ul style="list-style-type: none"> • Installation Guide (1) • Warning/Caution Information (1) 	
<p>USB Cable Clamp: (2ports) 2</p> 	<p>USB Holder Set: 1 (Fasteners: 1, screws: 2)</p> 
<p>Power Connector: 1</p> <div style="display: flex; justify-content: space-around; align-items: center;"> <div style="text-align: center;">  <p>AC type (5.08mm [0.20in.] pitch)</p> </div> <div style="text-align: center;">  <p>DC type (7.62mm [0.30in.] pitch)</p> </div> </div>	<p>Installation Fasteners (4 fasteners per set) PL-3600T Series: 1 set PL-3600K/3700T Series: 2 sets PL-3700K/3900T Series: 3 sets</p> 
<p>Installation Gasket: 1 (Attached to the PL unit)</p> 	<p>Power Switch Cover: 1 (AC type only) (cover: 1, screws: 2) *1</p> 

*1 The Power Switch Cover is packed in the PL unit approved ANSI/ISA standards, showing the appropriate revision code on the PL unit. Please see " Installation prerequisites for standards (page 13)".

IMPORTANT

- When installing the PL, be careful not to damage the built-in HDD.

NOTE

- If your PL unit contains a built-in accessory, that accessory's Installation Guide will also be included in the PL's packing box. Please check that all items normally included with that accessory are also included in this box.

This unit has been carefully packed, with special attention to quality. However, should you find anything damaged or missing, please contact your local PL distributor immediately.

Installation prerequisites for standards

IMPORTANT

- For the Built-in Battery Unit version's UL/c-UL Approval, see " 7.2.5 Installation prerequisites for standards (page 7-11)".

- UL listed products

Industrial Control Equipment	refer to UL508	see [a] in the "Product List"
Suitable for use in Class I, Division 2, Groups A, B, C, and D Hazardous (classified) locations, or Non-Hazardous Locations.	refer to ANSI/ISA 12.12.01	see [b] in the "Product List"

- c-UL listed products

Process Control Equipment	refer to CSA-C22.2 No.142	see [c] in the "Product List"
Suitable for use in Class I, Division 2, Groups A, B, C, and D Hazardous (classified) locations, or Non-Hazardous Locations.	refer to CSA-C22.2 No. 213	see [d] in the "Product List"

- Product List

Product Model No.	Registration Model No.	UL		c-UL	
		[a]	[b] ^{*1}	[c]	[d]
APL3000-BA	3582302-01	✓	✓	✓	✓
APL3000-BD	3582302-11	✓	✓	✓	✓
APL3600-TA	3582302-01 Front Module:3620003-01	✓	✓	✓	✓
APL3600-TD	3582302-11 Front Module:3620003-01	✓	✓	✓	✓
APL3700-TA	3582302-01 Front Module:3620003-02	✓	✓	✓	✓
APL3700-TD	3582302-11 Front Module:3620003-02	✓	✓	✓	✓
APL3900-TA	3582302-01 Front Module:3620003-03	✓	✓	✓	✓
APL3900-TD	3582302-11 Front Module:3620003-03	✓	✓	✓	✓
APL3600-KA	3582302-01 Front Module:3620003-04	✓	✓	✓	✓
APL3600-KD	3582302-11 Front Module:3620003-04	✓	✓	✓	✓
APL3700-KA	3582302-01 Front Module:3620003-05	✓	✓	✓	✓
APL3700-KD	3582302-11 Front Module:3620003-05	✓	✓	✓	✓

- *1 ANSI/ISA-compliant revisions are as follows;
 APL3*00-**-CD2G-** : Rev. D or later
 APL3*00-**-CM18-** : Rev. E or later

UL/c-UL File No.: E220851, E210412

For the detailed certification's information, refer to the Pro-face website.

<Cautions>

Be aware of the following items when building the PL into an end-use product:

PL-3000B series

- The PL unit is approved as an open-type unit.
- Install the PL unit on a flat surface. The PL unit must be mounted according to the installation requirements with the specified distance from adjacent structures and equipment. The temperature must be checked on the final product in which the PL is installed.

PL-3600*/3700*/3900T series

- The PL unit's rear face is not approved as an enclosure. When building the PL unit into an end-use product, be sure to use an enclosure that satisfies standards as the end-use product's overall enclosure.
- The PL unit must be used indoors only.
- Install and operate the PL with its front panel facing outwards.
- If the PL is mounted so as to cool itself naturally, be sure to install it in a vertical panel. Also, according to the installation requirements, create space around the rear face of the PL unit. The temperature must be checked on the final product in which the PL unit is installed.
- For use on a flat surface of a Type 4X (Indoor Use Only) and/or Type 12 Enclosure.
- Type 4X (Indoor Use Only) and/or 12 Enclosure, when the hatch for Front USB Port is secured by screw.
Type 1 Enclosure, when the hatch for Front USB Port is open.

<Compliance and Handling Cautions in Hazardous Locations>

- Suitable for use in Class I, Division 2, Groups A, B, C, and D Hazardous Locations only.
- WARNING: Explosion hazard - substitution of components may impair suitability for Class I, Division 2.
- WARNING: Explosion hazard - do not disconnect equipment while the circuit is live or unless the area is known to be free of ignitable concentrations.
- WARNING: Explosion hazard - When using the PL with the AC type power supply, be sure to attach the Power Switch Cover.

 5.3.2 Attachment of the Power Switch Cover (page 5-14)

The safety certificate can be downloaded from Pro-face website.

Home Page URL

<http://www.pro-face.com/>

<Control Drawing of USB I/F on PL's Front Module>

The information below concerns the use of the USB I/F located on the PL unit's front modules used in Class I, Division 2 Groups A, B, C, and D hazardous locations (from Doc No. 35016429).

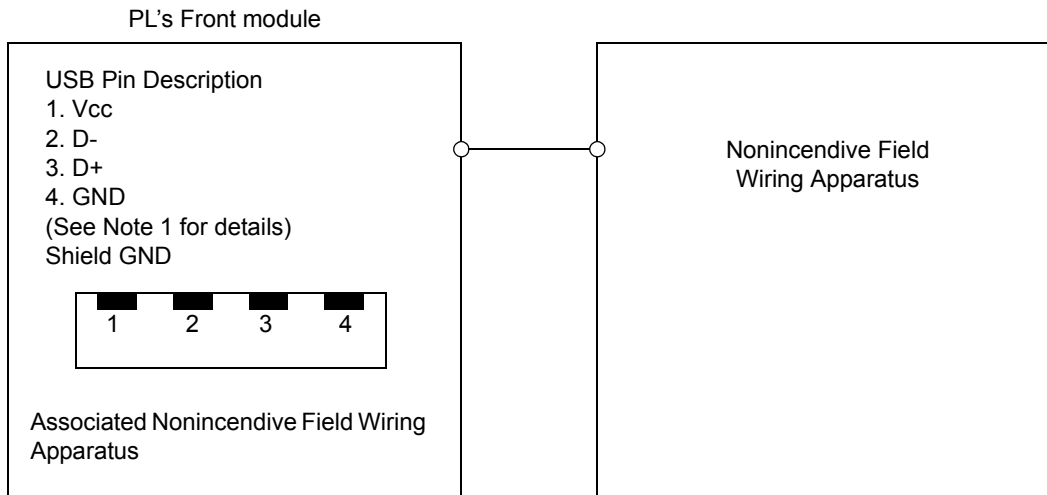

Notes:

1. Nonincendive Circuit Parameters:

Front USB Port:

$V_{oc} = 5.0 \text{ V}$

$I_{sc} = 1.25 \text{ A}$

$C_a = 10 \mu\text{F}$

$L_a = 16 \mu\text{H}$

2. Selected Associated Nonincendive Field Wiring Apparatus shall satisfy the following:

Nonincendive Field Wiring Apparatus	-	Front module of PL unit
V_{oc}	\leq	V_{max}
I_{sc}	\leq	I_{max}
C_a	\geq	$C_i + C_{\text{cable}}$
L_a	\geq	$L_i + L_{\text{cable}}$

3. If the electrical parameters of the cable are unknown, the following values may be used:

Capacitance = 60 pF/ft

Inductive = 0.20 $\mu\text{H}/\text{ft}$

4. Nonincendive Field Wiring must be installed in accordance with article 501.10(B) of the National Electrical Code ANSI/NFPA 70.

5. Nonincendive Field Wiring Apparatus shall not contain or be connected to another source of power.

CE Marking

The following units are CE marked product that conforms to EMC directives and Low Voltage Directives.

Product Model No.
APL3000-BA
APL3600-TA
APL3600-KA
APL3700-TA
APL3700-KA
APL3900-TA

The following units are CE marked products complying with the EMC Directive.

Product Model No.
APL3000-BD
APL3600-TD
APL3600-KD
APL3700-TD
APL3700-KD
APL3900-TD

For the detailed information on CE Marked, be downloaded and refer the Declaration of Conformity from Pro-face website.

Home Page URL

<http://www.pro-face.com/>

FCC Statement

United States FCC Part 15, Subpart B, Class A EMI Compliance Statement:

NOTE: This equipment has been tested and found to comply with the limits for a Class A digital device, pursuant to part 15 of the FCC Rules. These limits are designed to provide reasonable protection against harmful interference when the equipment is operated in a commercial environment. This equipment generates, uses, and can radiate radio frequency energy and, if not installed and used in accordance with the instruction manual, may cause harmful interference to radio communications. Operation of this equipment in a residential area is likely to cause harmful interference in which case the user will be required to correct the interference at his or her own expense.

About Revision

The nameplate on the PL has the revision code of the PL. In the example below, the asterisk, which is placed at the “A” position, shows that the revision code is “A”.

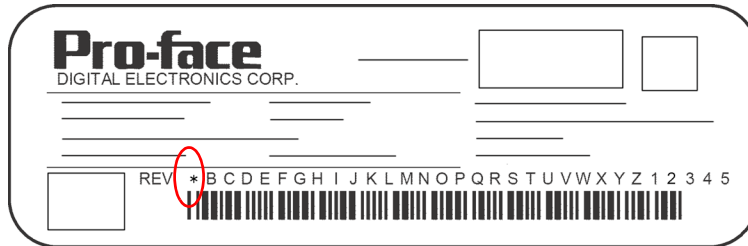

Contents

Preface.....	1
Essential Safety Precautions	2
Information Symbols	7
About the Manuals	7
PL3000 Series Model Name Indication.....	8
PL3000 Series Model Names	9
Package Contents.....	10
Installation prerequisites for standards	13
CE Marking	16
FCC Statement.....	16
About Revision	17
Contents.....	18

Chapter 1 Overview

1.1 System Design.....	1-2
1.2 Accessories	1-3
1.2.1 Optional Items.....	1-3
1.2.2 Maintenance Items.....	1-4
1.3 Power Supply.....	1-5

Chapter 2 Part Names and Functions

2.1 PL-3000B Series.....	2-2
2.2 PL-3600T/3700T Series.....	2-5
2.3 PL-3600K/3700K Series	2-8
2.4 PL-3900T Series.....	2-11

Chapter 3 Specifications

3.1 General Specifications.....	3-2
3.1.1 Electrical Specifications	3-2
3.1.2 Environmental Specifications	3-3
3.1.3 Structural Specifications.....	3-5
3.2 Function Specifications	3-7
3.2.1 Performance Specifications	3-7
3.2.2 Display Functions.....	3-9
3.3 Interface Specifications.....	3-10
3.4 Internal Switches Specifications	3-16
3.4.1 Internal switches of the control box.....	3-16
3.4.2 Internal switches of the front module	3-22

Chapter 4 Dimensions

4.1 PL-3000B Series.....	4-2
4.1.1 Dimensions of the 2 slot Unit (Installation fasteners attached).....	4-2
4.1.2 Dimensions of the 4 slot Unit (Installation fasteners attached).....	4-4
4.1.3 Cable Attached Dimensions.....	4-6
4.1.4 Dimensions of the Screw Holes.....	4-7
4.2 PL-3600T Series.....	4-8
4.2.1 Dimensions of the 2 slot Unit (Installation fasteners attached).....	4-8
4.2.2 Dimensions of the 4 slot Unit (Installation fasteners attached).....	4-9
4.2.3 Cable Attached Dimensions.....	4-10
4.2.4 Panel Cut Dimensions.....	4-11
4.2.5 Installation Fasteners.....	4-11
4.3 PL-3600K Series.....	4-12
4.3.1 Dimensions of the 2 slot Unit (Installation fasteners attached).....	4-12
4.3.2 Dimensions of the 4 slot Unit (Installation fasteners attached).....	4-13
4.3.3 Cable Attached Dimensions.....	4-14
4.3.4 Panel Cut Dimensions.....	4-15
4.3.5 Installation Fasteners.....	4-16
4.4 PL-3700T Series.....	4-17
4.4.1 Dimensions of the 2 slot Unit (Installation fasteners attached).....	4-17
4.4.2 Dimensions of the 4 slot Unit (Installation fasteners attached).....	4-18
4.4.3 Cable Attached Dimensions.....	4-19
4.4.4 Panel Cut Dimension.....	4-20
4.4.5 Installation Fasteners.....	4-20
4.5 PL-3700K Series.....	4-21
4.5.1 Dimensions of the 2 slot Unit (Installation fasteners attached).....	4-21
4.5.2 Dimensions of the 4 slot Unit (Installation fasteners attached).....	4-22
4.5.3 Cable Attached Dimensions.....	4-23
4.5.4 Panel Cut Dimension.....	4-24
4.5.5 Installation Fasteners.....	4-24
4.6 PL-3900T Series.....	4-25
4.6.1 Dimensions of the 2 slot Unit (Installation fasteners attached).....	4-25
4.6.2 Dimensions of the 4 slot Unit (Installation fasteners attached).....	4-26
4.6.3 Cable Attached Dimensions.....	4-27
4.6.4 Panel Cut Dimensions.....	4-28
4.6.5 Installation Fasteners.....	4-28

Chapter 5 Installation and Wiring

5.1 Installation.....	5-2
5.1.1 PL-3000B Series.....	5-2
5.1.2 PL-3600*/PL-3700*/PL-3900T Series.....	5-5

5.2	Installing/removing the front module and the control box	5-9
5.2.1	PL-3600T Series	5-9
5.2.2	PL-3600K/3700*/3900T Series	5-11
5.3	Peripheral Device Installation	5-13
5.3.1	Removal/Attachment of the Switch Cover	5-13
5.3.2	Attachment of the Power Switch Cover	5-14
5.3.3	Removal of Expansion Slot Cover	5-15
5.3.4	Main Memory Installation	5-16
5.3.5	Expansion Board Installation	5-16
5.3.6	HDD/SSD Unit Installation	5-18
5.3.7	CF Card Insertion/Removal	5-19
5.3.8	Connecting USB Cable Clamp	5-21
5.4	Wiring Precautions	5-23
5.4.1	Connecting the Power Cord	5-23
5.4.2	Connecting the Power Supply	5-27
5.4.3	Grounding	5-28
5.4.4	I/O Signal Line Placement	5-29

Chapter 6 Maintenance

6.1	Cleaning the Fan Filter	6-2
6.2	Periodic Check Points	6-4
6.3	Replacing the Installation Gasket	6-5
6.4	Replacing the Backlight	6-7
6.4.1	PL-3600* Series	6-7
6.4.2	PL-3700* Series	6-11
6.4.3	PL-3900T Series	6-15
6.5	Replacing the Internal Battery	6-16
6.5.1	Replacing the Battery for Backup of Internal Clock Data	6-16

Chapter 7 Built-in Options

7.1	DVD Drive Unit	7-2
7.1.1	Specifications	7-2
7.1.2	Dimensions (DVD drive unit built-in)	7-4
7.2	Battery Unit	7-7
7.2.1	Caution	7-7
7.2.2	Specification	7-9
7.2.3	Backup Battery	7-10
7.2.4	Replacing Battery Unit	7-10
7.2.5	Installation prerequisites for standards	7-11

After-sales service

1 | Overview

1. System Design
2. Accessories
3. Power Supply

This chapter describes peripheral devices that can be connected to PL unit.

1.1 System Design

The following diagram illustrates the standard range of items that can be connected to PL unit.

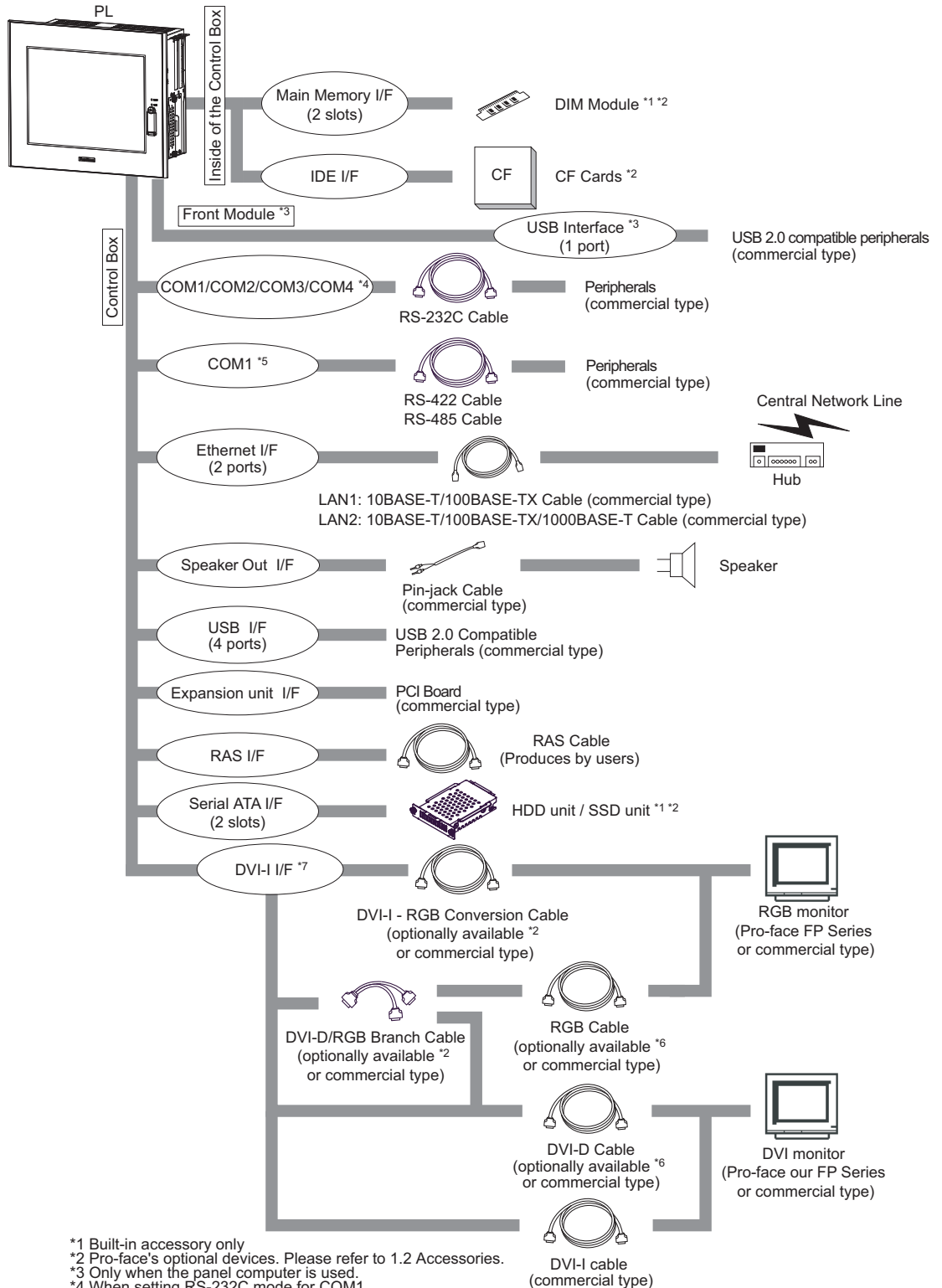

*1 Built-in accessory only
 *2 Pro-face's optional devices. Please refer to 1.2 Accessories.
 *3 Only when the panel computer is used.
 *4 When setting RS-232C mode for COM1.
 *5 When setting RS-422 or RS-485 mode for COM1.
 *6 Optional device for our FP Series flat panel display.
 *7 When the dual output with the front module is selected, the DVI-I can be connected to an analog RGB monitor only.

1.2 Accessories

All accessories listed here are produced by Pro-face.

1.2.1 Optional Items

Product Name	Model No.	Description
DIM module	CA7-DDR2-512MB	DDR2 Memory module 512MB
	CA7-DDR2-1GB	DDR2 Memory module 1GB
	CA7-DDR2-2GB	DDR2 Memory module 2GB
Hard Disk Unit	APL3000-HD60	HDD Unit mounted a Type 2.5 Hard Disk (60GB without OS)
	APL3000-HD250	HDD Unit mounted a Type 2.5 Hard Disk (250GB without OS)
SSD Unit	APL3000-SD16	Flash memory unit (16GB without OS)
CF Card	CA3-CFCALL/128MB-01	Type 1 128MB
	CA3-CFCALL/256MB-01	Type 1 256MB
	CA3-CFCALL/512MB-01	Type 1 512MB
	CA6-CFCALL/1GB-01	Type 1 1GB
	CA8-CFCALL/2GB-01	Type 1 2GB
USB Front Cable	CA5-USBEXT-01 (1m)	Extension cable attaching USB port to the panel
DVI-I - RGB Conversion Cable	CA7-CBLCVRGB-01	A cable converting DVI-I to RGB
DVI-D/RGB Branch Cable	CA7-CBLCVDVI-D/RGB-01	A branch cable converting DVI-I to DVI-D/RGB
AC Power Supply Connector (Right-angle)	CA7-ACCNLR-01	Right-angle power supply connector for attaching power supply cable (Set of 5 connectors)
DC Power Supply Connector (Right-angle)	CA5-DCCNL-01	Right-angle power supply connector for attaching power supply cable (Set of 5 connectors)
Software Mirroring Utility *1*2*3	APL-SM3000	Provides RAID Level 1 protection, without Mirror Disk unit.
Screen Protection Sheet	CA7-DFS12-01 (PL-3600* series)	Disposable sheet that protects the PL unit's screen from dust. (5 sheets per set)
	CA3-DFS15-01 (PL-3700* series)	
	CA7-DFS19-01 (PL-3900T series)	
Panel-Cut Conversion Attachment Brackets (PL-69X0 series)	APL3600-ATP69X0-01 (PL-3600T series)	Brackets to attach PL-3600T series to the panel cut holes of the PL 6900/6920/6930 series

*1 The software mirroring utility is corresponding to the following Hard Disk Unit, such as APL3000-HD60 and APL3000-HD250.

*2 To use the software mirroring utility, please use two Hard Disk units with the same capacity.

*3 The software mirroring utility is not corresponding to the SSD unit.

1.2.2 Maintenance Items

Product Name	Model No.	Supported PL model	Description
Installation Fastener	APL-ATFB-01	PL-3000B series	Used to install the PL unit. (Fasteners: 2, screws: 4)
	CA3-ATFALL-01	PL-3600* series PL-3700* series PL-3900T series	Used to install the PL unit into a solid panel.
AC Power Supply Connector (Straight)	CA7-ACCNL-01	PL3000 series (AC type)	Straight power supply connector for attaching power supply cable (Set of 5 connectors)
DC Power Supply Connector (Straight)	CA7-DCCNL-01	PL3000 series (DC type)	Straight power supply connector for attaching power supply cable (Set of 5 connectors)
Installation Gasket	CA7-WPG12-01	PL-3600T series	Provides dust and moisture resistance when the PL unit is installed into a solid panel.
	CA7-WPG15-01	PL-3600K series PL-3700T series	
	CA7-WPG15K-01	PL-3700K series	
	CA7-WPG19-01	PL-3900T series	
Replacement Backlight *1	CA3-BLU15-01	PL-3600* series	Backlight for replacement
	CA7-BLU15-01	PL-3700* series	

1 PL-3600/PL-3700* series backlights (LED backlights) and PL-3900T series backlights cannot be replaced by the user. For details on the backlight type, refer to the following page.

- 3.2.2 Display Functions (page 3-9)

When the backlight needs to be replaced, please contact your local PL distributor.

1.3 Power Supply

The PL has three kinds of power supply states: Non-energized, Normal State, and Soft OFF State*¹.

Each state is outlined in the following diagram:

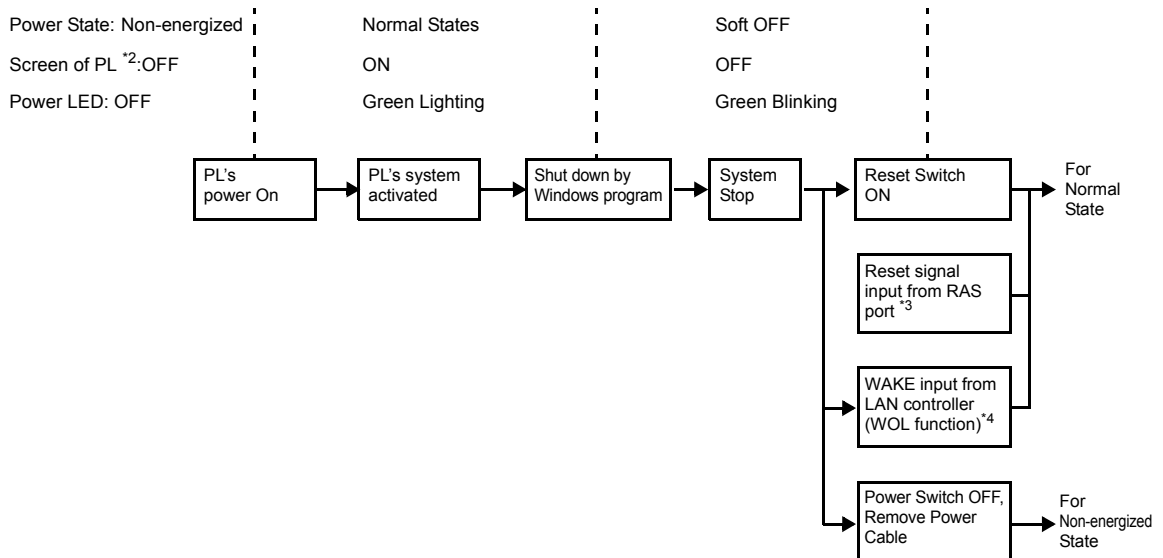

IMPORTANT

- Whenever you turn the PL unit's power OFF, wait until the internal HDD stops spinning (approximately 5 seconds) before turning the power ON again.

*1 The Soft OFF refers to the state when Windows[®] has been shut down and the power is provided only for the electric circuit to boot system. This Soft OFF State is different from Windows[®] System Standby.

*2 Only when the panel computer is used.

*3 **SEE →** ■ RAS Interfaces (page 3-13)

*4 The function that activates the PL unit via LAN. **SEE →** PL3000 Series Reference Manual

2



Part Names and Functions

1. PL-3000B Series
2. PL-3600T/3700T Series
3. PL-3600K/3700K Series
4. PL-3900T Series

This chapter describes the name and functions of PL unit.

2.1 PL-3000B Series

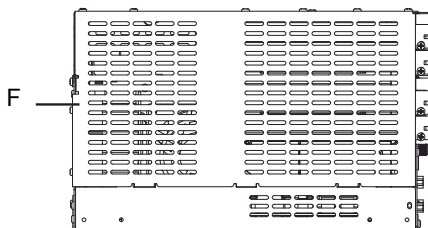
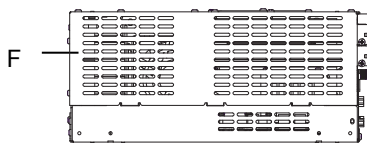
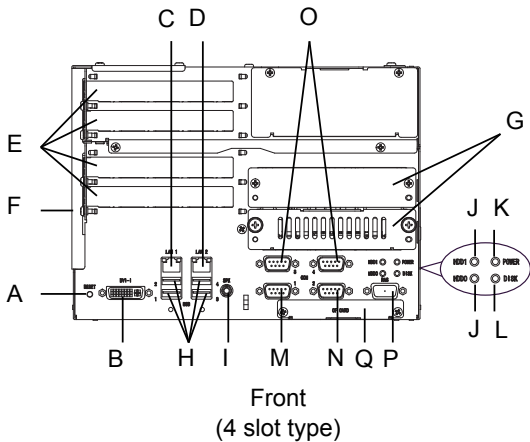
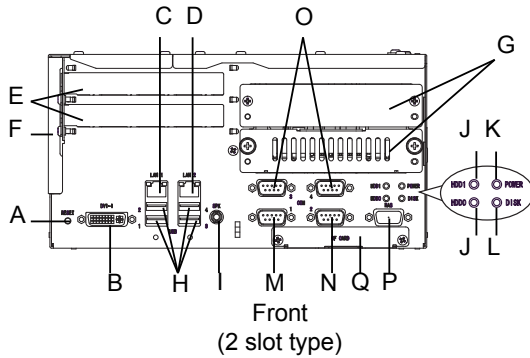

A: Hardware reset switch (RESET)

Restarts the PL unit during normal operation status.

In the Soft OFF status, resets the unit to the normal operation status.

B: DVI-I interface (DVI-I)

Interface with DVI monitor or analog RGB monitor. DVI-I 29 pin socket type.

C: Ethernet interface (LAN1)

10BASE-T/100BASE-TX/1000BASE-T Auto Changeover. This interface uses an RJ-45 type modular jack connector (8 pins).

D: Ethernet interface (LAN2)

10BASE-T/100BASE-TX Auto Changeover. This interface uses an RJ-45 type modular jack connector (8 pins).

E: Expansion slot

For expansion board (PCI). 2 slots or 4 slots.

F: Expansion slot cover

Expansion slot cover is removed when mounting expansion board and DIM module

G: HDD slot

For serial ATA HDD/SSD unit. HDD slot 0 and then HDD slot 1 from the bottom

H: USB interface (USB1/2/3/4)

4 ports. USB 2.0 compatible. Type-A connector is used.

I: Speaker output interface (SPK)

Mini pin jack connector

J: HDD status lamp

From bottom in diagram: the status lamp for HDD slot 0 and one for HDD slot 1

LED	Indicates
Green (lit)	HDD/SSD mounted (Normal operation)
Not lit	No HDD/SSD mounted

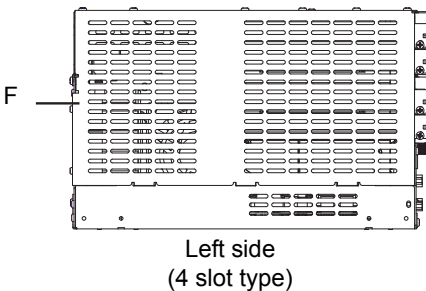
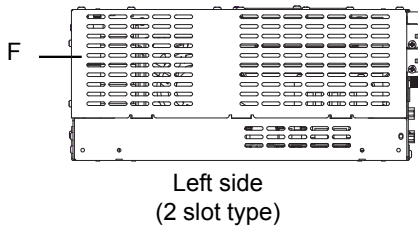
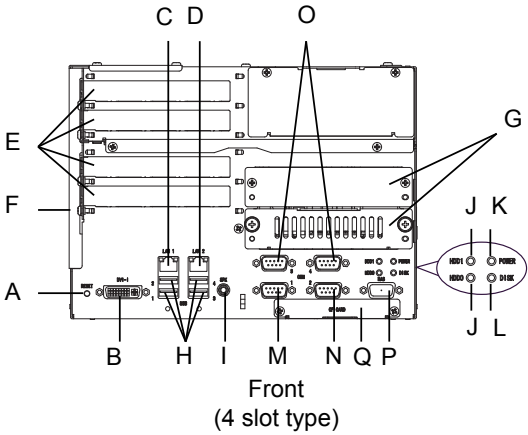
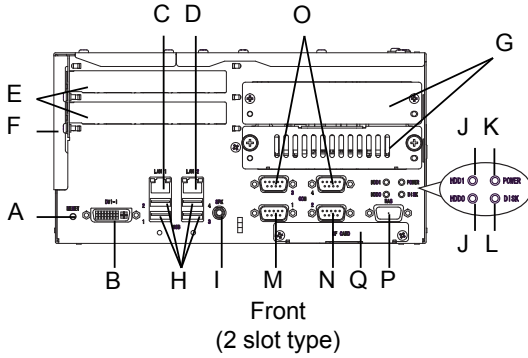

K: Power LED / RAS status lamp (POWER)

LED	Indicates
Green (lit)	Normal operation (power is on)
Green (blinking)	Soft OFF state
Orange (lit)	System monitor error (RAS error)
Not lit	Power is OFF

L: Disk access lamp (DISK)

LED	Indicates
Green (lit)	When HDD/SSD or IDE is accessed
Not lit	When neither HDD/SSD nor IDE is accessed

M: Serial interface (COM1)

D-Sub 9-pin plug type.

RS-232C, RS-422, RS-485 Changeover.

CI (RI)/+5V Changeover.

N: Serial interface (COM2)

D-Sub 9-pin plug type.

RS-232C.

CI (RI)/+5V Changeover.

O: Serial interface (COM3/COM4)

D-Sub 9-pin plug type.

RS-232C.

From left in diagram: COM3 and then COM4

P: RAS interface (RAS)

D-Sub 9-pin socket type.

Q: CF Card interface (CF CARD)

IDE-type connection*1.

CF Card (Type I/II) compatible is available.

IMPORTANT

- When attaching peripheral units to the PL, be sure the PL's power cord is disconnected from the main power supply.

*1 Since an IDE-type connection is used, the unit is not hot-swappable. When inserting/removing the CF Card, be sure that power is turned OFF.

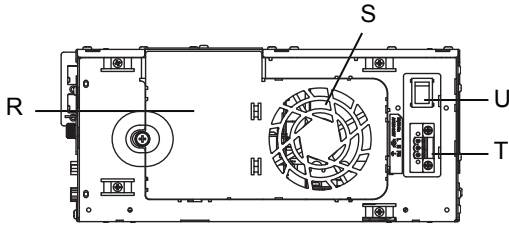

Right side
(2 slot type)

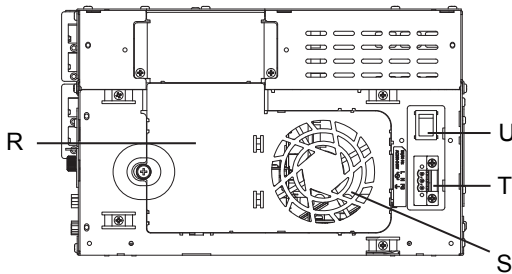

Right side
(4 slot type)

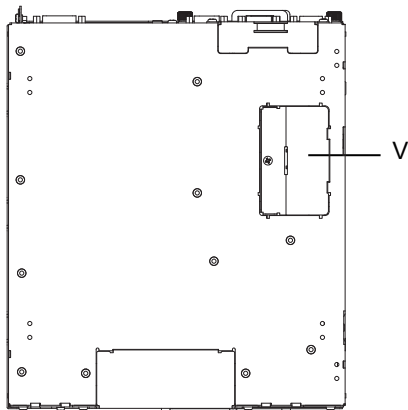

Bottom
(Common to 2 slot and
4 slot type)

R: Fan cover

System fan inside

S: System fan

A fan for cooling the PL unit

T: Power connector

U: Power switch

AC type only.

V: Switch cover

Remove switch cover when setting the DIP switch, slide switch, and replacing batteries for clock data backup.

2.2 PL-3600T/3700T Series

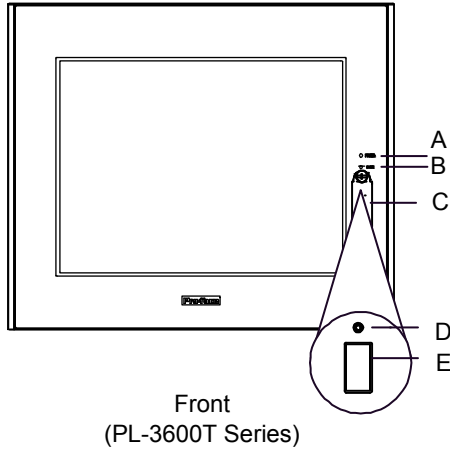

Front
(PL-3600T Series)

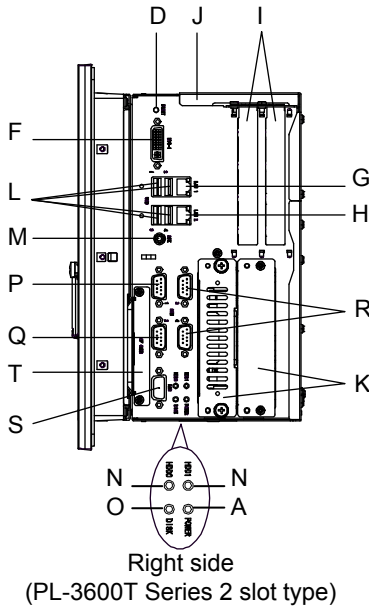

Right side
(PL-3600T Series 2 slot type)

A: Power LED / RAS Status Lamp (POWER)

LED	Indicates
Green (lit)	Normal operation (power is on)
Green (blinking)	Soft OFF state
Orange (lit)	System monitor error (RAS error)
Orange/Red (blinking)	Backlight burnout is detected
Not lit	Power is OFF

B: Disk Access Lamp (DISK)

LED	Indicates
Green (lit)	When HDD/SSD or IDE is accessed
Not lit	When neither HDD/SSD nor IDE is accessed

C: Front Cover

D: Hardware Reset Switch (RESET)

In the normal operation status, restarts the PL unit.
In the Soft OFF status, resets the unit to the normal operation status.

E: USB Interface (USB)

1 port. Complies with USB 2.0.
Uses a "TYPE-A" connector.

F: DVI-I interface (DVI-I)

For analog RGB output only. *1
DVI-I 29 pin socket type.

G: Ethernet interface (LAN1)

10BASE-T/100BASE-TX/1000BASE-T Auto
Changeover. This interface uses an RJ-45 type
modular jack connector (8 pins).

H: Ethernet interface (LAN2)

10BASE-T/100BASE-TX Auto Changeover. This
interface uses an RJ-45 type modular jack
connector (8 pins).

*1 DVI monitor cannot be connected. Connect Analog RGB monitor using DVI-I-RGB Conversion Cable.

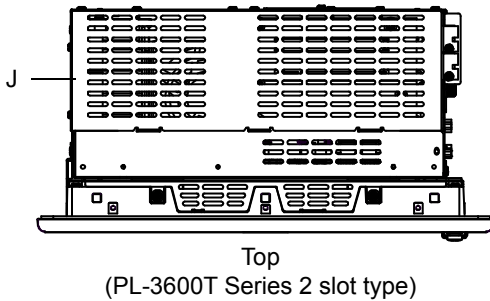
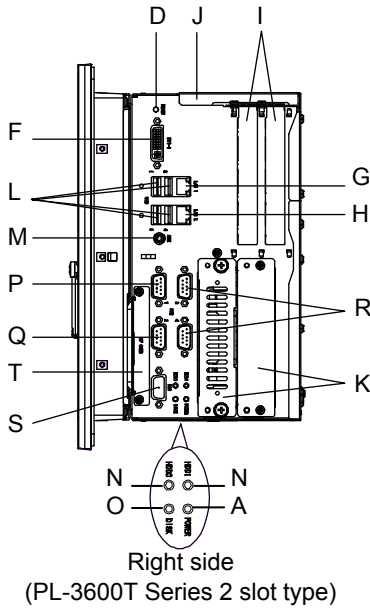

I: Expansion slot

For expansion board (PCI).
2 slots or 4 slots.

J: Expansion slot cover

Expansion slot cover is removed when mounting expansion board and DIM module

K: HDD slot

For serial ATA HDD/SSD unit.
From left in diagram: HDD slot 0 and then HDD slot 1

L: USB interface (USB1/2/3/4)

4 ports. USB 2.0 compatible.
Type-A connector is used.

M: Speaker output interface (SPK)

Mini pin jack connector

N: HDD status lamp

From left in diagram: the status lamp for HDD slot 0 and one for HDD slot 1

LED	Indicates
Green (lit)	HDD/SSD mounted (Normal operation)
Not lit	No HDD/SSD mounted

O: Disk access lamp (DISK)

LED	Indicates
Green (lit)	When HDD/SSD or IDE is accessed
Not lit	When neither HDD/SSD nor IDE is accessed

P: Serial interface (COM1)

D-Sub 9-pin plug type.
RS-232C, RS-422, RS-485 Changeover.
CI (RI)/+5V Changeover.

Q: Serial interface (COM2)

D-Sub 9-pin plug type.
RS-232C.
CI (RI)/+5V Changeover.

R: Serial interface (COM3/COM4)

D-Sub 9-pin plug type.
RS-232C.
From top in diagram: COM3 and then COM4

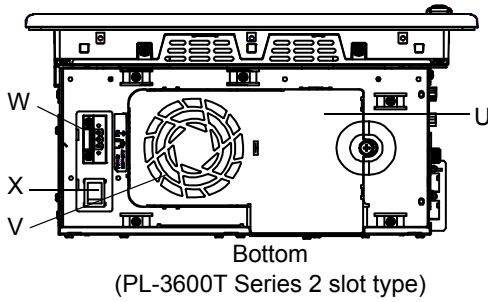
**S: RAS interface (RAS)**

D-Sub 9-pin socket type.

T: CF Card interface (CF CARD)

IDE-type connection *1.

CF Card (Type I/II) compatible is available.

U: Fan cover

System fan inside

V: System fan

A fan for cooling the PL unit

W: Power connector**X: Power switch**

AC type only.

IMPORTANT

- When attaching peripheral units to the PL, be sure the PL's power cord is disconnected from the main power supply.

*1 Since an IDE-type connection is used, the unit is not hot-swappable. When inserting/removing the CF Card, be sure that power is turned OFF.

2.3 PL-3600K/3700K Series

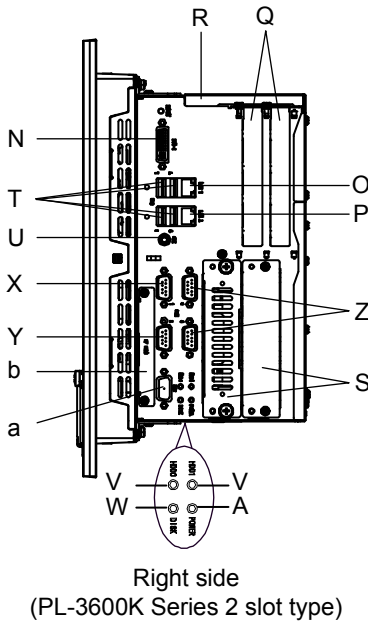
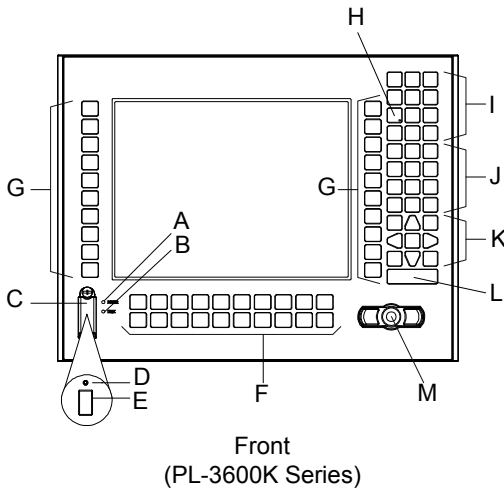

NOTE

- For detailed instruction of how to use the keypad, refer to PL3000 Series Reference Manual.

A: Power LED / RAS Status Lamp (POWER)

LED	Indicates
Green (lit)	Normal operation (power is on)
Green (blinking)	Soft OFF state
Orange (lit)	System monitor error (RAS error)
Orange/Red (blinking)	Backlight burnout is detected
Not lit	Power is OFF

B: Disk Access Lamp (DISK)

LED	Indicates
Green (lit)	When HDD/SSD or IDE is accessed
Not lit	When neither HDD/SSD nor IDE is accessed

C: Front Cover

D: Hardware Reset Switch (RESET)

In the normal operation status, restarts the PL unit.
In the Soft OFF status, resets the unit to the normal operation status.

E: USB Interface (USB)

1 port. Complies with USB 2.0.
Uses a "TYPE-A" connector.

F: Function keys

Used to input characters or functions.

G: Special function keys

Used to input characters or special functions.

H: F/A key

Function/Alpha key. Switches between function input and character input. The illuminating LED indicates that character input is enabled.

I: Window keys

J: Numeric keys

K: Cursor keys

L: Enter key

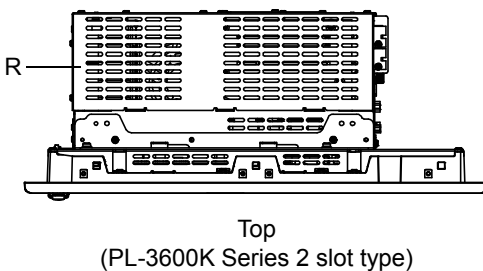
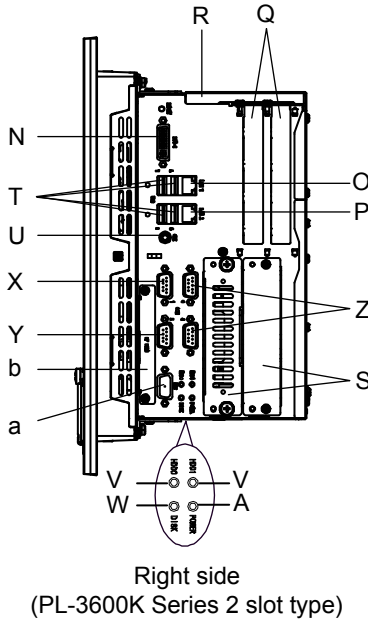
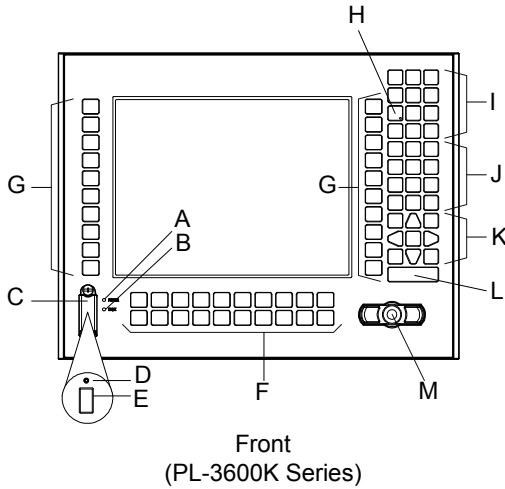

M: Mouse pointer

2-button mouse

N: DVI-I interface (DVI-I)

For analog RGB output only. *1

DVI-I 29 pin socket type.

O: Ethernet interface (LAN1)

10BASE-T/100BASE-TX/1000BASE-T Auto Changeover. This interface uses an RJ-45 type modular jack connector (8 pins).

P: Ethernet interface (LAN2)

10BASE-T/100BASE-TX Auto Changeover. This interface uses an RJ-45 type modular jack connector (8 pins).

Q: Expansion slot

For expansion board (PCI).

2 slots or 4 slots.

R: Expansion slot cover

Expansion slot cover is removed when mounting expansion board and DIM module

S: HDD slot

For serial ATA HDD/SSD unit.

From left in diagram: HDD slot 0 and then HDD slot 1

T: USB interface (USB1/2/3/4)

4 ports. USB 2.0 compatible.

Type-A connector is used.

U: Speaker output interface (SPK)

Mini pin jack connector

V: HDD status lamp

From Left in diagram: the status lamp for HDD slot 0 and one for HDD slot 1

LED	Indicates
Green (lit)	HDD/SSD mounted (Normal operation)
Not lit	No HDD/SSD mounted

*1 DVI monitor cannot be connected. Connect Analog RGB monitor using DVI-I-RGB Conversion Cable.

SEE → 1.1 System Design (page 1-2)

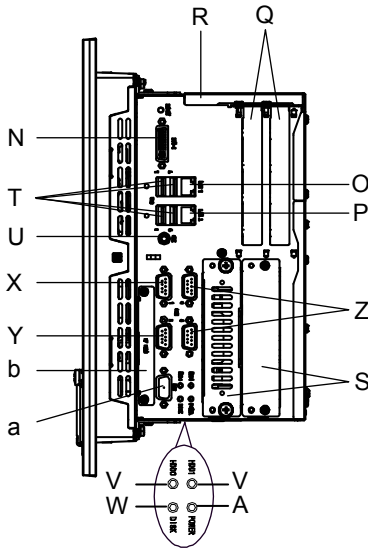

Right side
(PL-3600K Series 2 slot type)

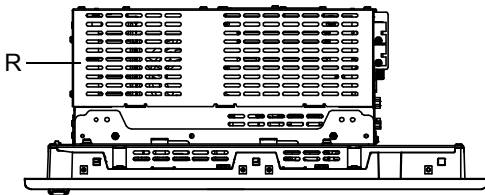

Top
(PL-3600K Series 2 slot type)

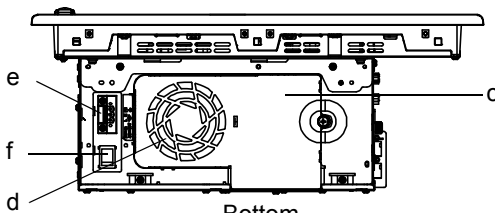

Bottom
(PL-3600K Series 2 slot type)

W: Disk access lamp (DISK)

LED	Indicates
Green (lit)	When HDD/SSD or IDE is accessed
Not lit	When neither HDD/SSD nor IDE is accessed

X: Serial interface (COM1)

D-Sub 9-pin plug type.
RS-232C, RS-422, RS-485 Changeover.
CI (RI)/+5V Changeover.

Y: Serial interface (COM2)

D-Sub 9-pin plug type.
RS-232C.
CI (RI)/+5V Changeover.

Z: Serial interface (COM3/COM4)

D-Sub 9-pin plug type.
RS-232C.
COM3 and then COM4 from the top

a: RAS interface (RAS)

D-Sub 9-pin socket type.

b: CF Card interface (CF CARD)

IDE-type connection *1.
CF Card (Type I/II) compatible is available.

c: Fan cover

System fan inside

d: System fan

A fan for cooling the PL unit

e: Power connector

f: Power switch

AC type only.

IMPORTANT

- When attaching peripheral units to the PL, be sure the PL's power cord is disconnected from the main power supply.

*1 Since an IDE-type connection is used, the unit is not hot-swappable. When inserting/removing the CF Card, be sure that power is turned OFF.

2.4 PL-3900T Series

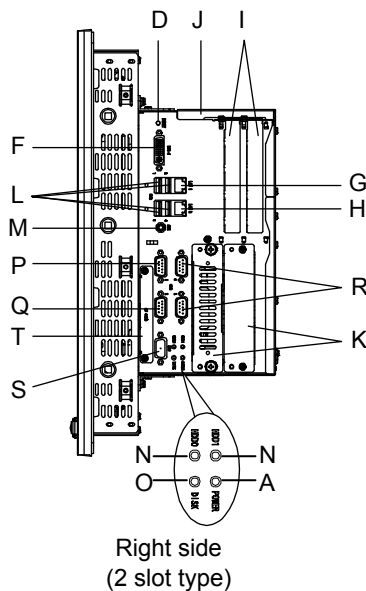
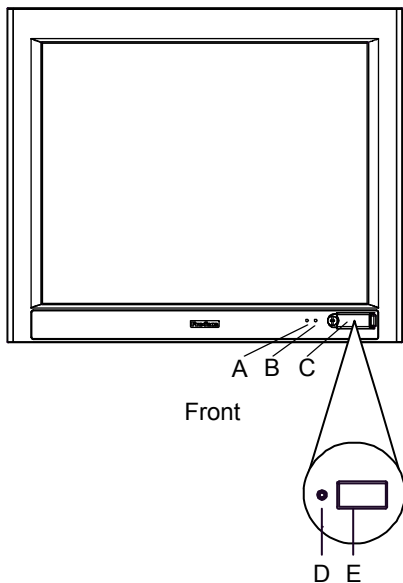

A: Power LED / RAS Status Lamp (POWER)

LED	Indicates
Green (lit)	Normal operation (power is on)
Green (blinking)	Soft OFF state
Orange (lit)	System monitor error (RAS error)
Orange/Red (blinking)	Backlight burnout is detected
Not lit	Power is OFF

B: Disk Access Lamp (DISK)

LED	Indicates
Green (lit)	When HDD/SSD or IDE is accessed
Not lit	When neither HDD/SSD nor IDE is accessed

C: Front Cover

D: Hardware Reset Switch (RESET)

In the normal operation status, restarts the PL unit.
In the Soft OFF status, resets the unit to the normal operation status.

E: USB Interface (USB)

1 port. Complies with USB 2.0.
Uses a "TYPE-A" connector.

F: DVI-I interface (DVI-I)

For analog RGB output only. *1
DVI-I 29 pin socket type.

G: Ethernet interface (LAN1)

10BASE-T/100BASE-TX/1000BASE-T Auto Changeover. This interface uses an RJ-45 type modular jack connector (8 pins).

H: Ethernet interface (LAN2)

10BASE-T/100BASE-TX Auto Changeover. This interface uses an RJ-45 type modular jack connector (8 pins).

*1 DVI monitor cannot be connected. Connect Analog RGB monitor using DVI-I-RGB Conversion Cable.

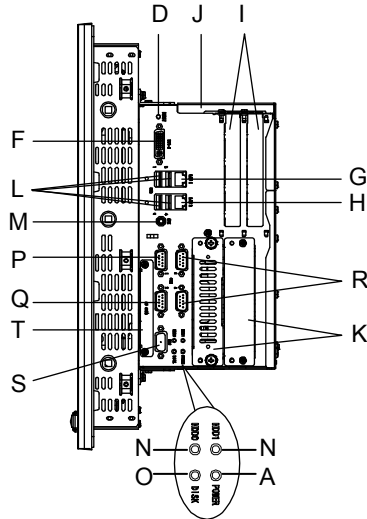

Right side
(2 slot type)

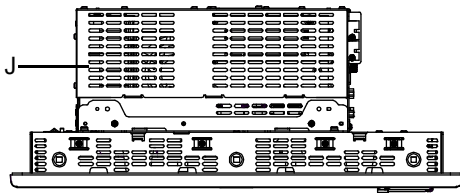

Top
(2 slot type)

I: Expansion slot

For expansion board (PCI).
2 slots or 4 slots.

J: Expansion slot cover

Expansion slot cover is removed when mounting expansion board and DIM module

K: HDD slot

For serial ATA HDD/SSD unit.
From left in diagram: HDD slot 0 and then HDD slot 1

L: USB interface (USB1/2/3/4)

4 ports. USB 2.0 compatible.
Type-A connector is used.

M: Speaker output interface (SPK)

Mini pin jack connector

N: HDD status lamp

From left in diagram: the status lamp for HDD slot 0 and one for HDD slot 1

LED	Indicates
Green (lit)	HDD/SSD mounted (Normal operation)
Not lit	No HDD/SSD mounted

O: Disk access lamp (DISK)

LED	Indicates
Green (lit)	When HDD/SSD or IDE is accessed
Not lit	When neither HDD/SSD nor IDE is accessed

P: Serial interface (COM1)

D-Sub 9-pin plug type.
RS-232C, RS-422, RS-485 Changeover.
CI (RI)/+5V Changeover.

Q: Serial interface (COM2)

D-Sub 9-pin plug type.
RS-232C.
CI (RI)/+5V Changeover.

R: Serial interface (COM3/COM4)

D-Sub 9-pin plug type.
RS-232C.
From top in diagram: COM3 and then COM4

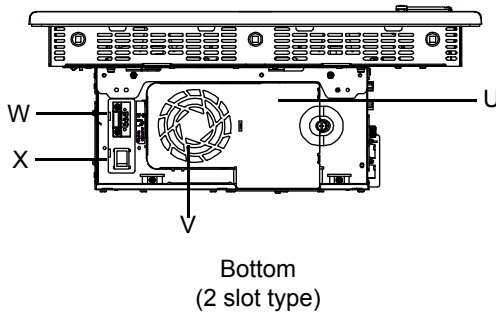
**S: RAS interface (RAS)**

D-Sub 9-pin socket type.

T: CF Card interface (CF CARD)

IDE-type connection *1.

CF Card (Type I/II) compatible is available.

U: Fan cover

System fan inside

V: System fan

A fan for cooling the PL unit

W: Power connector**X: Power switch**

AC type only.

IMPORTANT

- When attaching peripheral units to the PL, be sure the PL's power cord is disconnected from the main power supply.

*1 Since an IDE-type connection is used, the unit is not hot-swappable. When inserting/removing the CF Card, be sure that power is turned OFF.

3

Specifications

1. General Specifications
2. Function Specifications
3. Interface Specifications
4. Internal Switches Specifications

This chapter describes the general, functional and interface specifications of the PL unit.

3.1 General Specifications

3.1.1 Electrical Specifications

Power Supply		DC type	AC type
	Input Voltage	DC24V	AC100 to 240V
	Rated Voltage	DC19.2 to 28.8V	AC85 to 264V
	Rated Frequency	—	50/60Hz
	Allowable Frequency Range	—	47 to 63Hz
	Allowable Voltage Drop	5ms or less	1 cycle or less (Voltage drop interval must be 1s or more.)*1
	Power Consumption	145W or less However, 120W or lower for PL-3000B series 2-slot type	145VA or less However, 120VA or lower for PL-3000B series 2-slot type
	In-Rush Current	40A or less	
Voltage Endurance	AC1000V 20mA for 1minute (between charging and FG terminals)	AC1500V 20mA for 1minute (between charging and FG terminals)	
Insulation Resistance	DC500V 10MΩ (min.) (between charging and FG terminals)	DC500V 10MΩ (min.) (between charging and FG terminals)	

*1 Depending on the total of the expansion slot power and the external load power, the length of the allowable voltage drop will be 20 ms or less (excluding PL3000B series).
For details, refer to the graphs below.

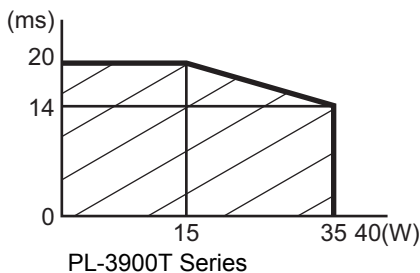
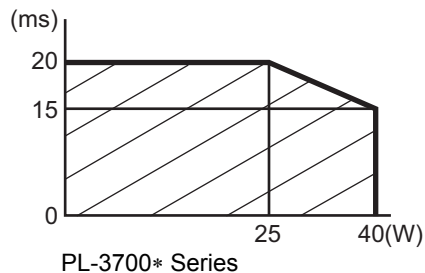
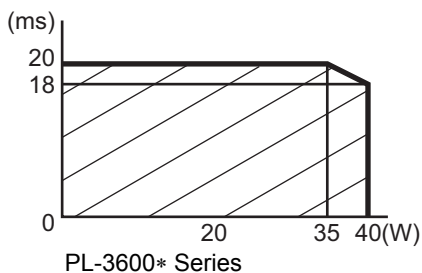

3.1.2 Environmental Specifications

Physical	Surrounding Air Temperature	0 to 50°C: without HDD *1 5 to 50°C: with HDD *1
	Storage Temperature	-20 to +60°C
	Ambient Humidity	10 to 90%RH (Not condensing, wet bulb temperature: 39°C or less. Wet bulb temperature with HDD *1: 29°C or less.)
	Storage Humidity	10 to 90%RH (Not condensing, wet bulb temperature: 39°C or less.)
	Dust	Free of dust
	Pollution Degree	For use in Pollution Degree 2 environment
	Corrosive gas	Free of corrosive gases
	Atmosphere (Using height)	800 to 1114 hPa (-300 to 2,000 meters above sea-level and below)
Mechanical	Vibration Resistance	Without HDD *1 IEC/EN61131-2 compliant 5 to 9 Hz single-amplitude 3.5mm [0.14in.] 9 to 150 Hz constant-acceleration 9.8m/s ² X, Y, Z directions for 10 cycle (100 minute)
		With HDD *1 10 to 57 Hz single-amplitude 0.075mm [0.003in.] 57 to 150 Hz constant-acceleration 9.8m/s ² X, Y, Z directions for 10 cycle (80 minute)
Electrical	Noise Immunity	Noise Voltage: 1500V _{P-P} Pulse Duration: 50ns, 500ns, 1µs Rise Time: 1ns (via noise simulator)
	Electrostatic Discharge Immunity	6kV (complies with IEC/EN 61000-4-2 Level 3)

*1 It is regarding whether SSD installing.

IMPORTANT

- When using any of the PL's optional devices, be sure to check that device's specifications for any special conditions or cautions that may apply to its use.
- Be aware that not only does the Hard Disk/SSD have a fixed lifetime, but that accidents can always occur. Therefore, be sure to back up your Hard Disk/SSD's data regularly, or prepare another Hard Disk/SSD unit that can be used for backup.
- The Hard Disk lifetime given here may be reduced due to unforeseen environmental factors. The following table shows the Hard Disk lifetime general factors.

	APL3000-HD60 (Rev.A)	APL3000-HD60 (Rev.B or later) APL3000-HD250
Factors	Operating temperature: 20°C, 333 hours of operation per month. (HDD access frequency of 20% or less)	Operating temperature: 20°C, 732 hours of operation per month. (HDD access frequency of 50% or less)
Lifetime	20,000 hours (of operation) or approximately 5 years, whichever comes first.	30,000 hours (of operation) or approximately 5 years, whichever comes first.

IMPORTANT

- Using the Hard Disk in an environment that is excessively hot and/or humid will shorten the disk's usage lifetime. A wet bulb temperature of 29°C or less is recommended. This is equivalent to the following data.

Temperature	at 35°C	at 40°C
Humidity	no higher than 64% RH	no higher than 44% RH

- In order to extend the lifetime of the hard disk, Pro-face recommends you set Windows® to turn the hard disk off when the unit is not being operated. A setting of 5 minutes is recommended. In Windows® 2000, click [Start]-[Control Panel]-[Power Options]-[Turn off hard disks]. In Windows® XP, click [Start]- [Control Panel]-[Power Options]-[Turn off hard disks].
- Do not vibrate the hard disk continuously at the same frequency. Doing so may cause the hard disk to reduce transfer speeds or stop temporarily.
- The SSD unit has a limited number of writes. Exceeding the guaranteed number of writes could make it impossible to read and write data, or systems may become unstable resulting in malfunctions.
- You can calculate the expected lifetime of the SSD unit based on the number of writes.

$$\text{Expected lifetime (years) based on the number of writes} = \frac{\text{SSD memory capacity [MB]} \times \text{Guaranteed number of writes}}{\text{Amount of data written each minute [MB]} \times \text{Number of writes per minute} \times 525,600 \text{ [minutes]}}$$

SSD memory capacity *1 : 15,631 MB

Guaranteed number of writes: 1 hundred thousand

The expected lifetime when writing 512 MB of data once per minute is approximately 6 years.

Depending on the system and software, data writes may actually be run several times even when only one write command is made. This can lead to actual lifetimes significantly different from expected lifetimes.

In order to make more accurate lifetime predictions, please use Pro-face's System Monitor, which is included with the PL unit.

*1 The SSD unit incorporates the Static Wear Leveling function. When calculating the expected lifetime, do not omit areas used by OS.

3.1.3 Structural Specifications

		PL-3000B Series	PL-3600* Series PL-3700* Series PL-3900T Series	
Installation	Grounding	AC type: Protective grounding: Grounding resistance of 100Ω, 2mm ² or thicker wire, or your country's applicable standard. (Same for FG and SG terminals) DC type: Functional grounding: Grounding resistance of 100Ω, 2mm ² or thicker wire, or your country's applicable standard. (Same for FG and SG terminals)		
	Structure *1	Installation configuration: Standing alone	Rating: Equivalent to IP65f NEMA #250 TYPE 4X/12 (value on the front face when installing the PL unit into a solid panel under the condition that the front USB is NOT used.) Installation configuration: Panel embedding	
	Cooling Method	Forced air cooling by the CPU fan		
	Weight	SEE → ■ <i>Weight (page 3-6)</i>		
	External Dimensions	SEE → <i>4.1 PL-3000B Series (page 4-2)</i>	SEE → <i>PL-3600T Series (page 4-8)</i> <i>PL-3600K Series (page 4-12)</i> <i>PL-3700T Series (page 4-17)</i> <i>PL-3700K Series (page 4-21)</i> <i>PL-3900T Series (page 4-25)</i>	
	Panel Cut Dimensions	SEE → <i>4.1.4 Dimensions of the Screw Holes (page 4-7)</i>	SEE → <i>PL-3600T Series (page 4-11)</i> <i>PL-3600K Series (page 4-15)</i> <i>PL-3700T Series (page 4-20)</i> <i>PL-3700K Series (page 4-24)</i> <i>PL-3900T Series (page 4-28)</i>	

*1 The front face of the PL unit, installed in a solid panel, has been tested using conditions equivalent to the standards shown in the specification. Even though the PL unit's level of resistance is equivalent to these standards, oils that should have no effect on the PL can possibly harm the unit. This can occur in areas where either vaporized oils are present, or where low viscosity cutting oils are allowed to adhere to the unit for long periods of time. If the PL's front face protection sheet becomes peeled off, these conditions can lead to the ingress of oil into the PL and separate protection measures are suggested. Also, if non-approved oils are present, it may cause deformation or corrosion of the front panel's plastic cover. Therefore, prior to installing the PL be sure to confirm the type of conditions that will be present in the PL's operating environment. If the installation gasket is used for a long period of time, or if the unit and its gasket are removed from the panel, the original level of the protection cannot be guaranteed. To maintain the original protection level, be sure to replace the installation gasket regularly.

■ Weight

Series	Weight	
	2 slot type (unit only)	4 slot type (unit only)
PL-3000B Series	6.0kg [13.2lb] max. (unit only)	7.5kg [16.5lb] max. (unit only)
PL-3600T Series	8.0kg [17.64lb] max. (unit only)	9.0kg [19.84lb] max. (unit only)
PL-3600K Series	11.0kg [24.25lb] max. (unit only)	12.0kg [26.46lb] max. (unit only)
PL-3700T Series	12.0kg [26.46lb] max. (unit only)	13.0kg [28.66lb] max. (unit only)
PL-3700K Series	13.0kg [28.66lb] max. (unit only)	14.0kg [30.86lb] max. (unit only)
PL-3900T Series	14.0kg [30.86lb] max. (unit only)	15.0kg [33.07lb] max. (unit only)

3.2 Function Specifications

3.2.1 Performance Specifications

CPU	Intel® Core™ Duo 2.0 GHz	Intel® Celeron® M 440 1.86GHz
L2 Cache Memory	2 MB (Built in the CPU)	1 MB (Built in the CPU)
Main Memory	DDR2 SDRAM (PC4200), 512MB/1GB/2GB (SO-DIMM socket x 2 slots) (SEE →) ■ <i>Additional Memory Combinations (page 3-8)</i>	
Chipset	Intel® 945GME + ICH7M	
BIOS	Phoenix® TrustedCore™ BIOS	
Graphics accelerator	Built in Intel® 945GME	
Video Memory	Max.64MB (When using Windows®) UMA Type	
Graphics	VGA (640 x 480 dots) to UXGA (1600 x 1200 dots)*1	
Touch Panel *2	Type	Resistive Film (Analog)
	Resolution	1024 x 1024
	Service Life	1,000,000 times or more, Sweeping 100,000 times or more
	Interface	Internal USB
Key Switch *3	No. of switches	74
	Switch type	Membrane switch
	Server Life	1,000,000 times or more
	Interface	Internal USB
Interface	Serial ATA	Serial ATA Rev. 1.0a x 2 2.5 inch HDD Unit or SSD Unit
	IDE*4	Master: CF Card Slot (Type I/II compatible) x 1 Slave: DVD Drive x 1
	Serial (COM1)	RS-232C (RS-232C/422/485 switch possible, RI/+5V switch possible.) Connector: D-sub 9 pin plug
	Serial (COM2)	RS-232C (RI/+5V switch possible) Connector: D-sub 9 pin plug
	Serial (COM3)	RS-232C Connector: D-sub 9 pin plug
	Serial (COM4)	RS-232C Connector: D-sub 9 pin plug
	RAS	Connector: D-Sub 9 pin socket For further details of the RAS function, refer to the "PL3000 Series Reference Manual".
	USB	USB 2.0 Connector: USB TYPE-A Control box: x4, Front module: x1 *2 Power Supply Voltage: DC5V±5% Output Current: 500mA (Max.) Maximum communication distance: 5m
	Ethernet (LAN1)	Intel® 82573 IEEE802.3u, 10BASE-T/100BASE-TX/1000BASE-T Auto Changeover Connector: Modular jack (RJ-45)
	Ethernet (LAN2)	Intel® 82562 PHY + ICH7M IEEE802.3u, 10BASE-T/100BASE-TX Auto Changeover Connector: Modular jack (RJ-45)
	Sound	SPEAKER OUT Connector: Mini pin jack x1
	Video	DVI-I OUT *5 Connector: DVI-I 29 pin socket x1 When the dual output with the front module is selected, the DVI-I can be connected to an analog RGB monitor only.

Expansion slot	PCI Rev.2.3 (33MHz) 2 slots/4 slots (SEE →) ■ <i>Expansion Slots (page 3-8)</i>
Clock Accuracy*6	±180 sec. /month (range of error depending on the situation temperature and power-off)

- *1 Even though the monitor connected to a PL unit matches the specifications of the PL unit's output signal, the display may not be correct. Please test your monitor with the PL unit prior to operation.
- *2 Only when the panel computer is used.
- *3 Only when the panel computer with Keypad is used.
- *4 Do not insert or remove the unit connected to the IDE during conduction because the unit does not support hot-swap.
- *5 When connecting Pro-face FP3000 Series to PL-3000B Series, use the Pro-face DVI-D cable (10m) FP-DV01-100. For details, please refer to "3.4.1 Internal switches of the control box" (page 3-16).
- *6 The clock, RTC, built-in the PL unit has a slight timing error. The range if the error will be between +300 and -300 sec. / month, depending on the PL unit's conditions such as lifetime usage or temperature difference. If you use the PL unit in a system where timing is critical, adjust the clock in regular intervals.

■ **Additional Memory Combinations**

When adding more memory, it is recommended to install it in the combinations shown below for the best performance.

Total capacity	Slot 1	Slot 2
512MB	512MB	—
1GB	512MB	512MB
	1GB	—
2GB	1GB	1GB
	2GB	—
4GB	2GB	2GB

■ **Expansion Slots**

Slot Type	Slot No.	Compliant bus	Available board size
2 slot type 4 slot type	Slot 1	PCI Rev.2.3 (5 V)	180 x 106.68mm [7.09 x 4.2in.] or less
	Slot 2		
4 slot type	Slot 3		255 x 106.68mm [10.04 x 4.2in.] or less
	Slot 4		

■ **Expansion slot supply current and external load current limit**

Provide the expansion slots so that the external load current including the power-supply current load for the PCI and the power-supply current load for the USB, RAS and COM does not exceed the values described in the table below.

◆ **Total current load**

Power Supply Capacity		DC5V	DC12V	DC-12V	DC3.3V
Current load	PCI (2 slots)	2.0A	1.0A	0.1A	1.0A
	PCI (4 slots)	4.0A	1.0A	0.1A	2.0A
	USB (4 ports)	2.0A	—	—	—
	USB (5 ports)*1	2.5A	—	—	—
	RAS (1 port)	—	0.1A	—	—
	COM (2 ports)	1.0A	—	—	—

*1 Only when the panel computer is used.

◆ Current load per port

Power Supply Capacity		DC5V	DC12V	DC-12V	DC3.3V
Current load	USB	0.5A	—	—	—
	RAS	—	0.1A	—	—
	COM	0.5A	—	—	—

Also, provide the expansion slots so that the external load power does not exceed the values described in the table below.

Model	External load power
PL-3000B Series	40W
PL-3600T Series	
PL-3600K Series	
PL-3700T Series	
PL-3700K Series	
PL-3900T Series	35W

3.2.2 Display Functions

	PL-3600* Series	PL-3700* Series	PL-3900T Series
Display Type	TFT Color LCD		
Display Size	12.1 inch	15 inch	19 inch
Pixel Density	800 x 600 pixels (SVGA)	1,024 x 768 pixels (XGA)	1,280 x 1,024 pixels (SXGA)
Dot Pitch	0.3075 x 0.3075mm	0.297 x 0.297mm	0.297 x 0.297mm
Effective Display Area	248.0 x 186.5mm	306.2 x 230.1mm	376.32 x 301.056mm
Display Colors	262,144 Colors		
Backlight's Life Span	When front module Rev.5 ^{*1} is NOT marked: CCFL		CFL (User non-replaceable parts, return system to distributor.)
	When front module Rev.5 ^{*1} is marked: LED backlight(The backlight cannot be replaced by the user. The unit must be sent back for backlight replacement.)		
Touch Panel Brightness Adjustment	4 Levels (Adjusted with the software.)		
Contrast Control	Not available		
Backlight Service Life	50,000hrs. or more (at ambient temperature 25°C and continuous operation - period until backlight brightness decreases to 50% or backlight starts to flicker)		

- *1 The revision number of the front module is shown in the label affixed to the front module.
In the example shown below,an asterisk "*" is displayed in the position where "5" should be, meaning "Rev.5".

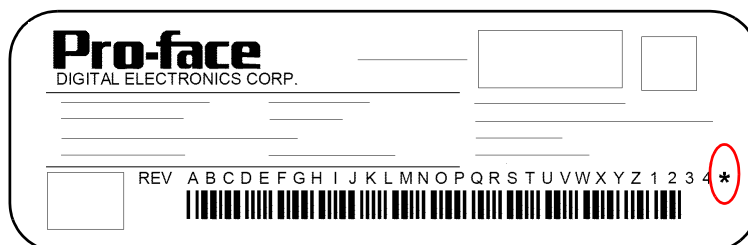

3.3 Interface Specifications

This section describes the specifications of each interface of the PL Series unit.

IMPORTANT

- This PL unit’s serial port is not isolated. Always connect the #5 SG (Signal Ground) of the PL unit to the connected device, especially if the connected device is also not isolated. Failure to do so may damage the RS232C/RS422/RS485 circuit.
- The SG (signal ground) and FG (frame ground) terminals are connected internally in the PL unit. When connecting the SG line to another device, be sure that the design of the system/connection does not produce a shorting loop.
- Connect FG terminal line to housing.
- Do not connect any pins to COM1 [NC].

■ Serial Interfaces

◆ Serial Interfaces (COM1)

This interface is used to connect an RS-232C/RS-422/RS-485*¹ serial cable. A D-sub 9-pin plug connector is used.

Interfit Bracket	#4-40 (UNC)
------------------	-------------

RS-232C

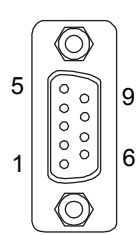
Pin Arrangement	Pin No.	RS-232C		
		Signal Name	Direction	Description
 <p>(PL unit side)</p>	1	CD	Input	Carrier Detect
	2	RD(RXD)	Input	Receive Data
	3	SD(TXD)	Output	Send Data
	4	ER(DTR)	Output	Data Terminal Ready
	5	SG	—	Signal Ground
	6	DR(DSR)	Input	Data Set Ready
	7	RS(RTS)	Output	Request to Send
	8	CS(CTS)	Input	Clear to Send
	9	CI(RI)/+5V	Input/—	Called status display +5V Output 0.5A ²
	Shell	FG	—	Frame Ground (Common with SG)

*1 To change the communication method, set the DIP switch located on the circuit board in the PL unit to the desired position. The factory setting is RS-232C. Please refer to “3.4 Internal Switches Specifications” (page 3-16).

*2 To change the CI (RI)/+5V setting of pin #9, set the slide switch located on the circuit board in the PL unit to the desired position. Please refer to “3.4 Internal Switches Specifications” (page 3-16).

RS-422

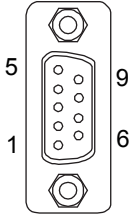
Pin Arrangement	Pin No.	RS-422		
		Signal Name	Direction	Description
 <p>(PL unit side)</p>	1	RDA	Input	Receive Data A(+)
	2	RDB	Input	Receive Data B(-)
	3	SDA	Output	Send Data A(+)
	4	ERA	Output	Data Terminal Ready A(+)
	5	SG	—	Signal Ground
	6	CSB	Input	Clear to Send B(-)
	7	SDB	Output	Send Data B(-)
	8	CSA	Input	Clear to Send A(+)
	9	ERB	Output	Data Terminal Ready B(-)
	Shell	FG	—	Frame Ground (Common with SG)

RS-485

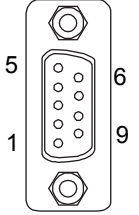
Pin Arrangement	Pin No.	RS-485		
		Signal Name	Direction	Description
 <p>(PL unit side)</p>	1	DATA+	Input/Output	Send/Receive Data (+)
	2	DATA-	Input/Output	Send/Receive Data (+)
	3	NC	—	No Connection
	4	NC	—	No Connection
	5	SG	—	Signal Ground
	6	NC	—	No Connection
	7	NC	—	No Connection
	8	NC	—	No Connection
	9	NC	—	No Connection
	Shell	FG	—	Frame Ground (Common with SG)

◆ Serial Interfaces (COM2/COM3/COM4)

This interface is used to connect an RS-232C serial cable. A D-sub 9-pin plug connector is used.

Interfit Bracket	#4-40 (UNC)
------------------	-------------

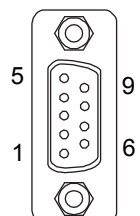
Pin Arrangement	Pin No.	RS-232C		
		Signal Name	Direction	Description
 <p>(PL unit side)</p>	1	CD	Input	Carrier Detect
	2	RD(RXD)	Input	Receive Data
	3	SD(TXD)	Output	Send Data
	4	ER(DTR)	Output	Data Terminal Ready
	5	SG	—	Signal Ground
	6	DR(DSR)	Input	Data Set Ready
	7	RS(RTS)	Output	Request to Send
	8	CS(CTS)	Input	Clear to Send
	9	CI(RI)/+5V	Input/—	Called status display +5V Output 0.5A ^{*1 *2}
	Shell	FG	—	Frame Ground (Common with SG)

*1 Only COM2 can be changed to +5V output. COM3 and COM4 are fixed at CI (RI).

*2 To change the CI (RI)/+5V setting of pin #9, set the slide switch located on the circuit board in the PL unit to the desired position. See “3.4 Internal Switches Specifications (page 3-16)”.

■ RAS Interfaces

D-sub 9 pin socket connector

IMPORTANT

- Be sure to use only the rated voltage level when using pin #1 (DC+12V) for external power output. Failure to do so can lead to a unit malfunction or accident.

Interfit Bracket	#4-40 (UNC)
------------------	-------------

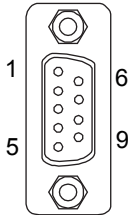
Pin Arrangement	Pin No.	Signal Name	Description
 <p>(PL unit side)</p>	1	+12 V	Output Current: 100mA or less Output Voltage: DC12V±5%
	2	DOUT0(+)	Data out 0(+)
	3	DOUT1(+)	Data out 1(+)
	4	DIN0(+)	Data in 0(+)
	5	DIN1(+)	Data in 1(+) ^{*1}
	6	GND	Ground
	7	DOUT0(-)	Data out 0(-)
	8	DOUT1(-)	Data out 1(-)
	9	DINCOM	Data in common

*1 Can be used for inputting the reset signals.

NOTE

- For further details of the RAS function, see the “PL3000 Series Reference Manual”.

◆ General Purpose Signal Input (DIN 0, 1)

Input Voltage		DC12V to 24V
Input Method		Sink / Source Input
Input Current		10mA (DC24V)
Input Resistance		3.6kΩ
Input Points		2 points (common with external reset input)
Operation Range	ON voltage	DC10V or more
	OFF voltage	DC3V or less
Isolation Method		Photocoupler Isolation
Dielectric Strength Voltage		500V or more

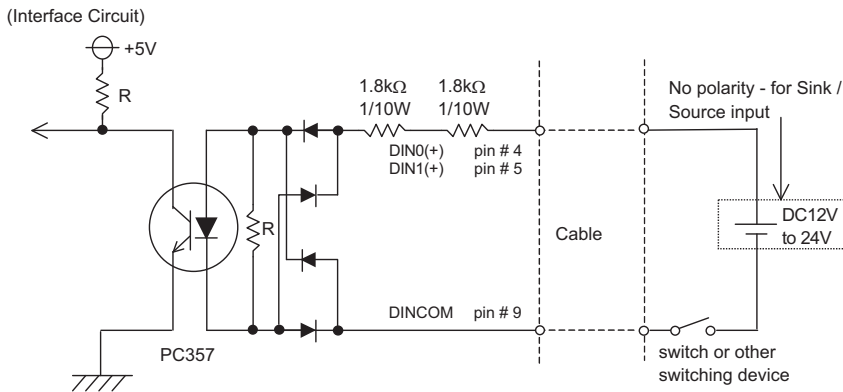

IMPORTANT

- General-Purpose Input (DIN) level must be 1.5 seconds or longer to be detected. It may not detect under 1.5 seconds.
- Be sure the voltage value between terminals is controlled via the input voltage, so that the PL is operated within its recommended range. If the input voltage exceeds this range, a malfunction or PL damage may occur.
- With Sink/Source input, even if the DIN(-), and RESET(-) are positive, and DIN(+), RESET(+) are negative, no problems are created. Be sure to operate the unit within the recommended voltage range.

◆ General Purpose Signal Output (DOUT 0, 1)

Rated Voltage	DC12V to 24V
Maximum Load Current	120mA/point
Out Voltage Drop	1.5V or less (at 100mA load current)
Output Points	2 points
Isolation Method	Photocoupler Isolation
Dielectric Strength Voltage	500V or more
External Power Supply	DC12V / 100mA

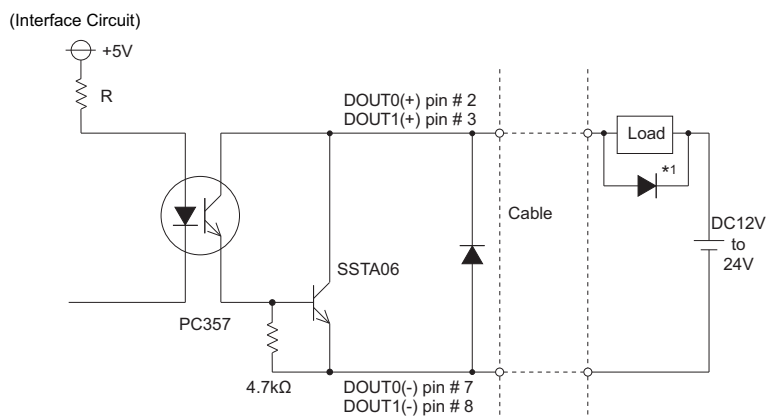
**IMPORTANT**

- Be sure to operate the unit within its maximum load current. If the maximum load current exceeds this range, a malfunction or PL damage may occur.
- Design your electrical system by adding the load current and voltage values to the terminal voltage. If load current value used is large, the voltage drop of 1.5V or less will occur between the terminals.
- When connecting an induction load, be sure to connect the above drawing's protection diode (*1).

3.4 Internal Switches Specifications

The internal switches are mounted on the bottom face of the control box and the rear face of the front module.

To operate these switches, remove the control box from the front module.

- SEE →** 5.2 Installing/removing the front module and the control box (page 5-9)
- 5.3.1 Removal/Attachment of the Switch Cover (page 5-13)

3.4.1 Internal switches of the control box

The following five switches are mounted on the inside of the control box.

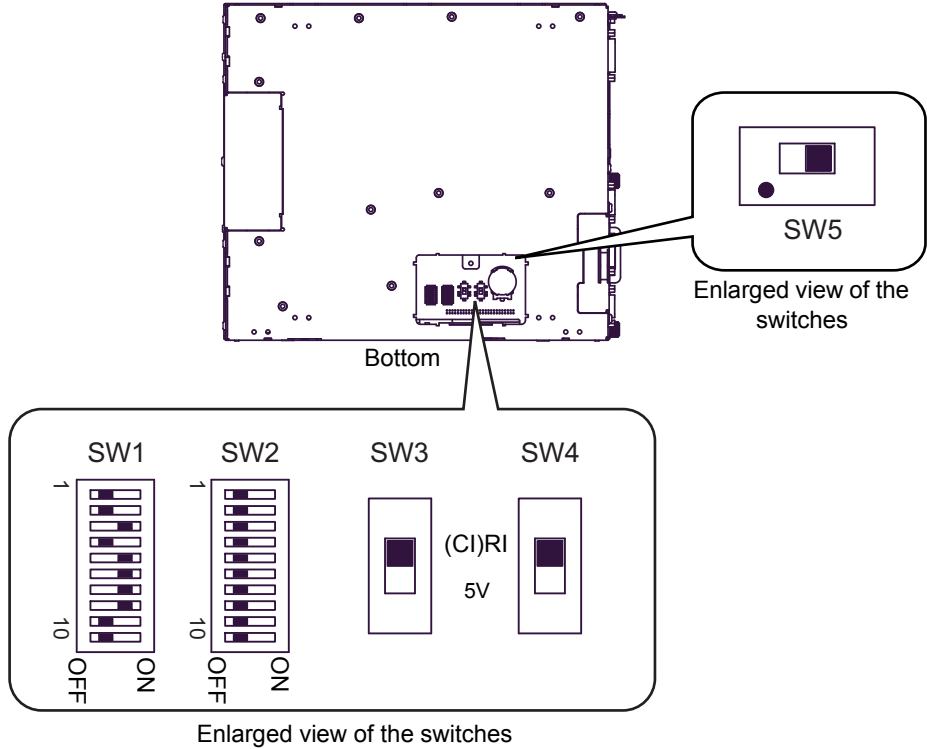

Switch Location	Switch Name	Compatible I/F	Factory Settings	Description
SW1	System Set Switch	-	See ■ System Set Switch (page 3-18).	10-point DIP switch. For System Set Switch and the factory settings details, see ■ System Set Switch (page 3-18).
SW2	Serial Mode Select Switch	COM1	All OFF (RS-232C)	10-point DIP switch. Designates COM1 communication settings. For Serial Mode Select Switch details, see ■ Serial Mode Select Switch (page 3-19).
SW3	CI(RI)+5 V Changeover Switch	COM2	CI(RI)	Not available on the built-in battery unit version.
SW4	CI(RI)+5 V Changeover Switch	COM1	CI(RI)	Changes # 9 pin (CI(RI) /+5 V).

Switch Location	Switch Name	Compatible I/F	Factory Settings	Description
SW5 *1	DVI Cable Selection Switch	–	 <p>Set to opposite side of the ● symbol. (FP-DV01-100 is not supported)</p>	<p>Toggles between supporting and not supporting the FP-DV01-100 [DVI-D cable (10m)], a Pro-face FP3000 Series option.</p> <p>For details, see ■ <i>DVI Cable Selection Switch (page 3-21)</i>.</p>

*1 PL-3000B series units with revision code “B” or later are compliant with SW5.

SEE → *About Revision (page 17)*

IMPORTANT

- Make sure to turn off the power supply before using the switches. Adjusting the switches while power is supplied may cause errors.

■ System Set Switch

Switch No.	Description	ON	OFF	Factory Settings	Notes
1	Internal setting	Reserved	Reserved	OFF	Do not change. (Factory setting)
2	Implements the logical inversion operation for RAS output	Normal Close	Normal Open	OFF	RAS output is a CLOSE state when the Switch and the system is ON. When the Switch is OFF, it is the opposite. The RAS Output keeps Normal OPEN when the Soft OFF state occurs or the power turns OFF.
3	Sets up an enabled/disabled state for the front USB port execution control function *1 *2	Enabled	Disabled	ON*3	The front USB port is available when the switch is ON. It is unavailable when the switch is OFF.
4	Internal setting	Reserved	Reserved	OFF	Do not change. (Factory setting)
5	Internal setting	Reserved	Reserved	ON	Do not change. (Factory setting)
6	Internal setting	Reserved	Reserved	ON	Do not change. (Factory setting)
7	Internal setting	Reserved	Reserved	ON	Do not change. (Factory setting)
8	Internal setting	Reserved	Reserved	ON*3	Do not change. (Factory setting)
9	Internal setting	Reserved	Reserved	OFF	Do not change. (Factory setting)
10	Internal setting	Reserved	Reserved	OFF	Do not change. (Factory setting)

*1 For panel computer only

*2 The Setting up an enabled/Disabled state for USB port execution control function is available for only Windows® 2000 and Windows® XP. Make sure to disable the function of the setting when other OS is used.

*3 As for PL-3000B Series without revisions, it's been set OFF as factory settings on SW No.3 and 8.

SEE → *About Revision (page 17)*

■ Serial Mode Select Switch

Switch No.	Description	ON	OFF	RS-232C	RS-422	RS-485 (The data is not automatically controlled via the RS (RTS) signal.) ^{*3}	RS-485 (The data is automatically controlled via the RS (RTS) signal.) ^{*3}
1	Internal setting	Reserved	Reserved	OFF ^{*1}	OFF ^{*1}	OFF ^{*1}	OFF ^{*1}
2	Changes COM1's communication method	RS-422/ RS-485	RS-232C	OFF	ON	ON	ON
3	Changes COM1's communication method	RS-422/ RS-485	RS-232C	OFF	ON	ON	ON
4	Changes SD(TXD) data's output mode	SD(TXD) data output is controlled via the RS(RTS) signal.	SD(TXD) data output is NOT controlled via the RS(RTS) signal. (normally output)	OFF	ON/ OFF	ON	OFF
5	Switches the SD(TXD) termination resistance ON/OFF	Inserts termination resistance of 220Ω between SDA and SDB.	No termination	OFF	ON	ON/OFF ^{*2}	ON/OFF ^{*2}
6	Switches the RD(RXD) termination resistance ON/OFF	Inserts termination resistance of 220Ω between RDA and RDB.	No termination	OFF	ON	ON/OFF ^{*2}	ON/OFF ^{*2}
7	Switches the shorting of SDA and RDA ON or OFF	Shorts SDA and RDA (RS-485 mode)	No shorting (RS-422 mode)	OFF	OFF	ON	ON
8	Switches the shorting of SDB and RDB ON or OFF	Shorts SDB and RDB (RS-485 mode)	No shorting (RS-422 mode)	OFF	OFF	ON	ON
9	RS(RTS) Automatic control mode (enabled only when RS-485 mode)	The data is automatically controlled via the RS(RTS) signal.	The data is not automatically controlled via the RS(RTS) signal.	OFF	OFF	OFF	ON
10	OFF			OFF	OFF	ON	

*1 Be sure to leave these settings OFF.

*2 If you use the termination resistance, base your settings on the connection specifications.

*3 This setting determines whether or not the SD (TXD) output driver is automatically controlled via the RS (RTS) signal.

Serial Mode Select Switches (SW4 to SW10) operate as shown in the circuit diagram below.

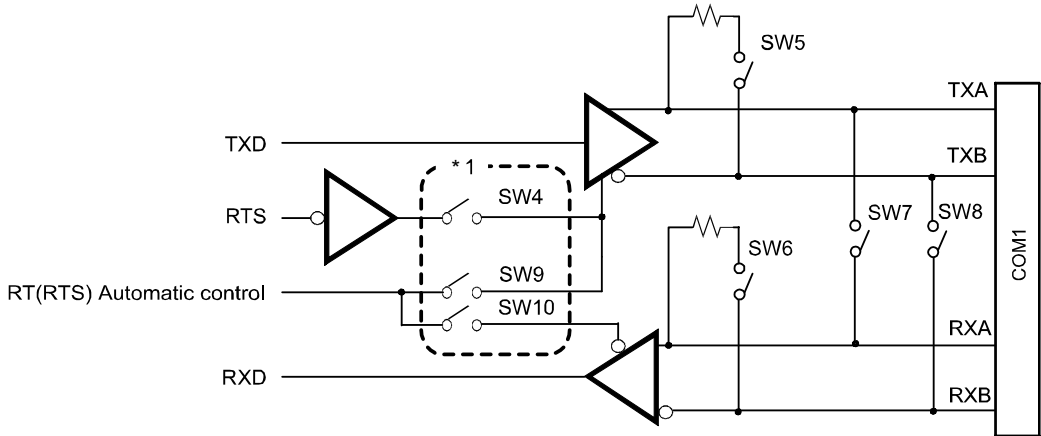

IMPORTANT

- Be sure to confirm the setting that will be used by the other device and set the switches accordingly. Failure to do so can lead to an accident or unit malfunction.

*1 Set switches number 9 and 10 to ON when the SD (TXD) output driver is automatically controlled with RS (RTS). Set switch number 4 to OFF.
 Set switches number 9 and 10 to OFF when the SD (TXD) output driver is controlled with the RS (RTS) signal. Set switch number 4 to ON.

■ DVI Cable Selection Switch

When connecting Pro-face FP3000 Series to PL-3000B Series unit, use the FP-DV01-100 (10m) Pro-face DVI-D cable. (Other 10m DVI cables are not supported)

When using FP-DV01-100, change DVI Cable Selection Switch (SW5) settings.

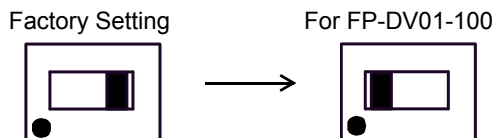

IMPORTANT

- When using the display unit with a cable other than FP-DV01-100 (such as FP-DVD01-50) use the Factory Setting.

NOTE

- The default Resolution and Screen Refresh Rates are as follows.
Resolution : SVGA (800x600) Screen
Refresh Rate : 60Hz
Maximum resolution varies depending on the FP3000 Series models. Please customize it for your FP model.

3.4.2 Internal switches of the front module.

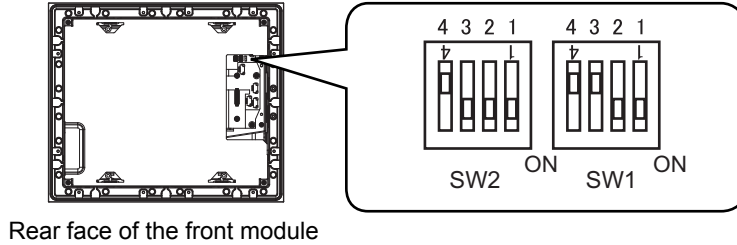

Switch Location	Switch Name	Factory Settings	Description
SW1	Touch Panel Set Switch	1 to 2: ON 3 to 4: OFF	4-point DIP switch. For Touch Panel Set Switch details, see ■ Touch Panel Set Switch.
SW2	—	Version Dependant	Internal setting. Do not change. (Factory setting) PL-3600T/3600K Series: 1:ON, 2:ON, 3:ON, 4:OFF PL-3700T/3700K Series: 1:ON, 2:OFF, 3:ON, 4:OFF PL-3900T Series: 1:OFF, 2:OFF, 3:ON, 4:OFF

■ Touch Panel Set Switch

Switch No.	Description	ON	OFF	Factory Settings	Notes
1 to 2	Internal setting	Reserved	Reserved	ON	Do not change. (Factory setting)
3				OFF	
4	Cancellation function of two point touch on the touch panel *1	Enabled	Disabled	OFF	The middle point is not considered to be touched when the switch is ON. It is considered to be touched when the switch is OFF.

*1 When two points are pushed, it is considered that middle point between the two points is touched according to the nature of the analog resistive touch panel. When the switch, etc. is set on the middle point, it will be enabled and may operate. To prevent such a switch from malfunction in case of pushing two points, turn ON Switch No.4 in advance, then the middle point will be disabled for two point touch.

4 | Dimensions

1. PL-3000B Series
2. PL-3600T Series
3. PL-3600K Series
4. PL-3700T Series
5. PL-3700K Series
6. PL-3900T Series

This chapter describes dimensions of the PL unit.

4.1 PL-3000B Series

The PL-3000B Series can be installed in any of the following three methods: vertical, horizontal, or wall mounting.

SEE → 5.1.1 PL-3000B Series (page 5-2)

4.1.1 Dimensions of the 2 slot Unit (Installation fasteners attached)

■ Horizontal mounting or wall mounting

Unit: mm [in.]

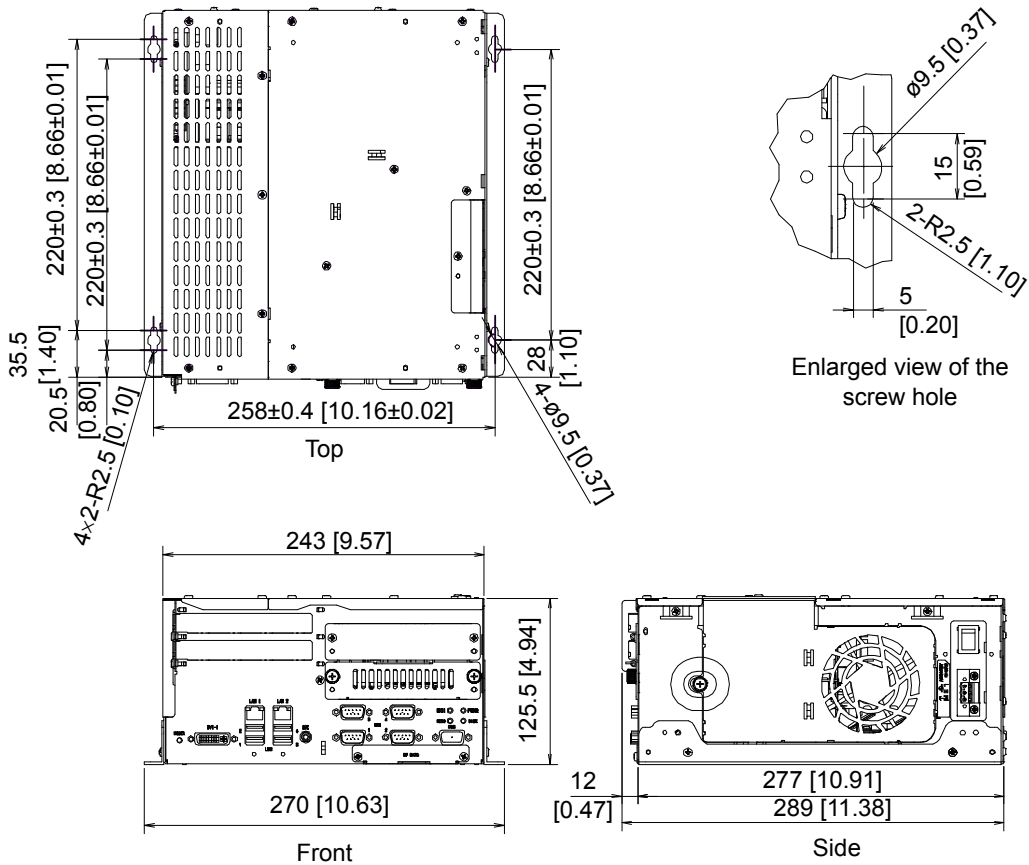

■ Vertical mounting

Unit: mm [in.]

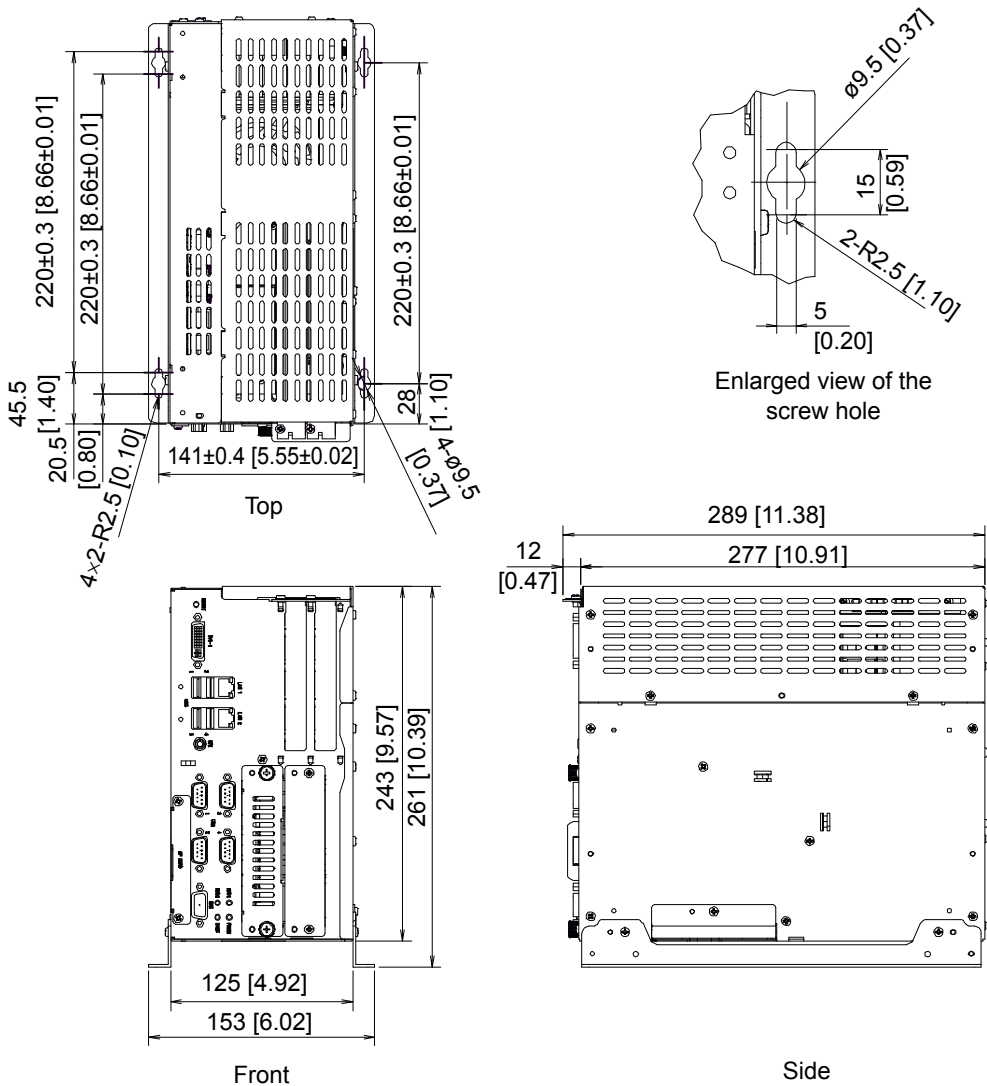

4.1.2 Dimensions of the 4 slot Unit (Installation fasteners attached)

■ Horizontal mounting or wall mounting

Unit: mm [in.]

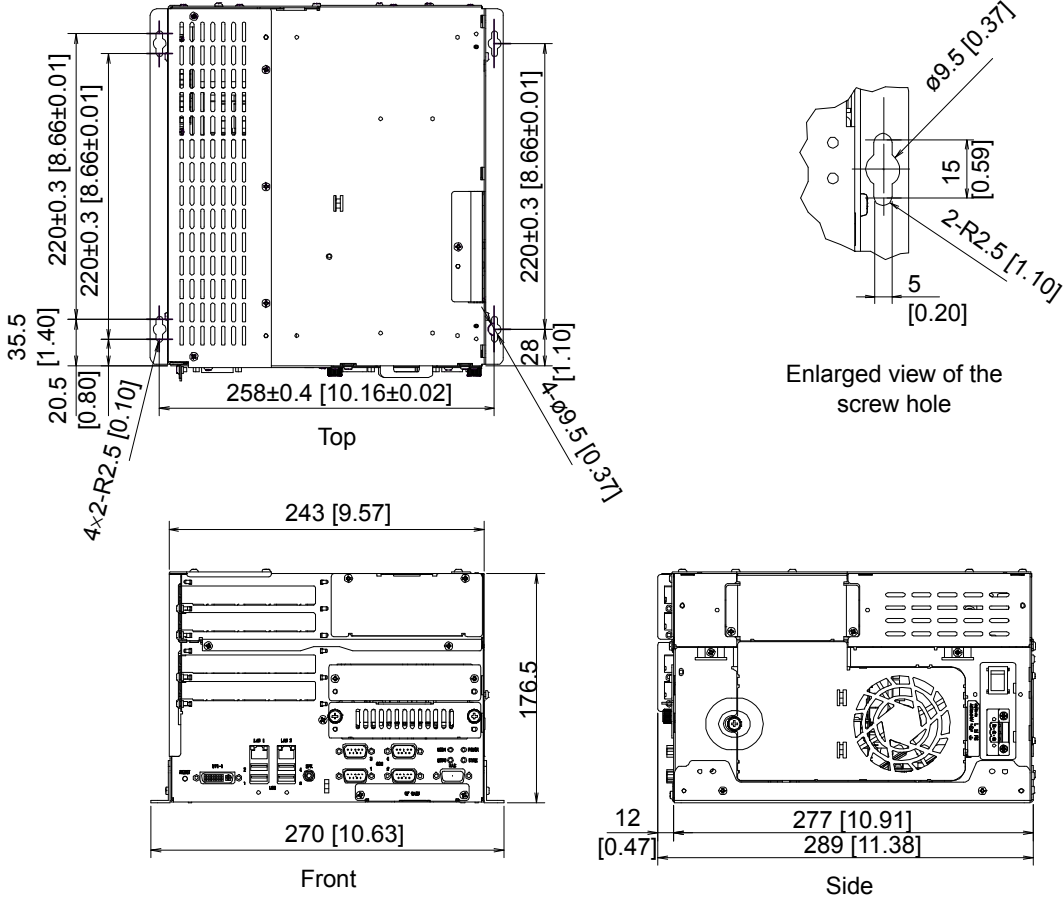

■ Vertical mounting

Unit: mm [in.]

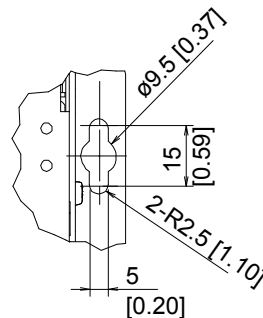
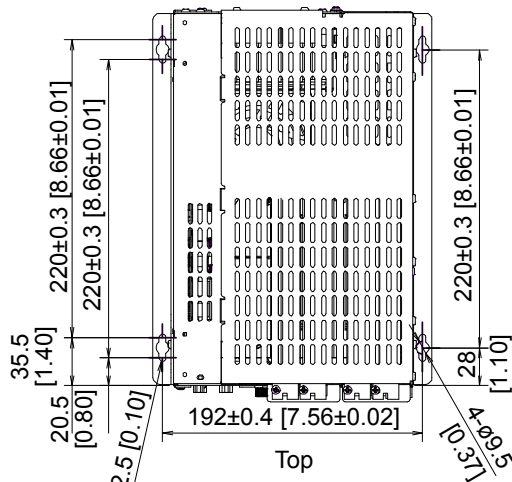

Enlarged view of the screw hole

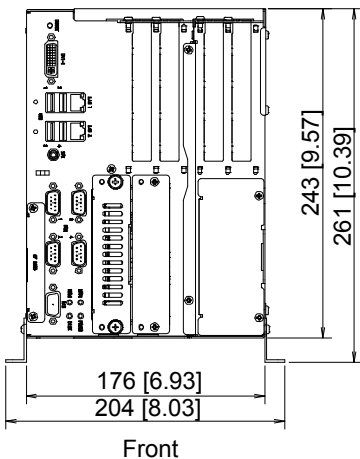

Front

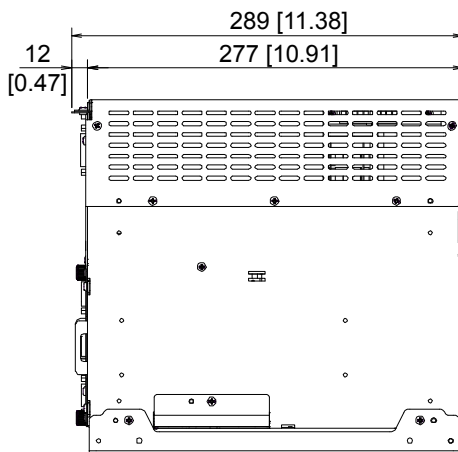

Side

4.1.3 Cable Attached Dimensions

Unit: mm [in.]

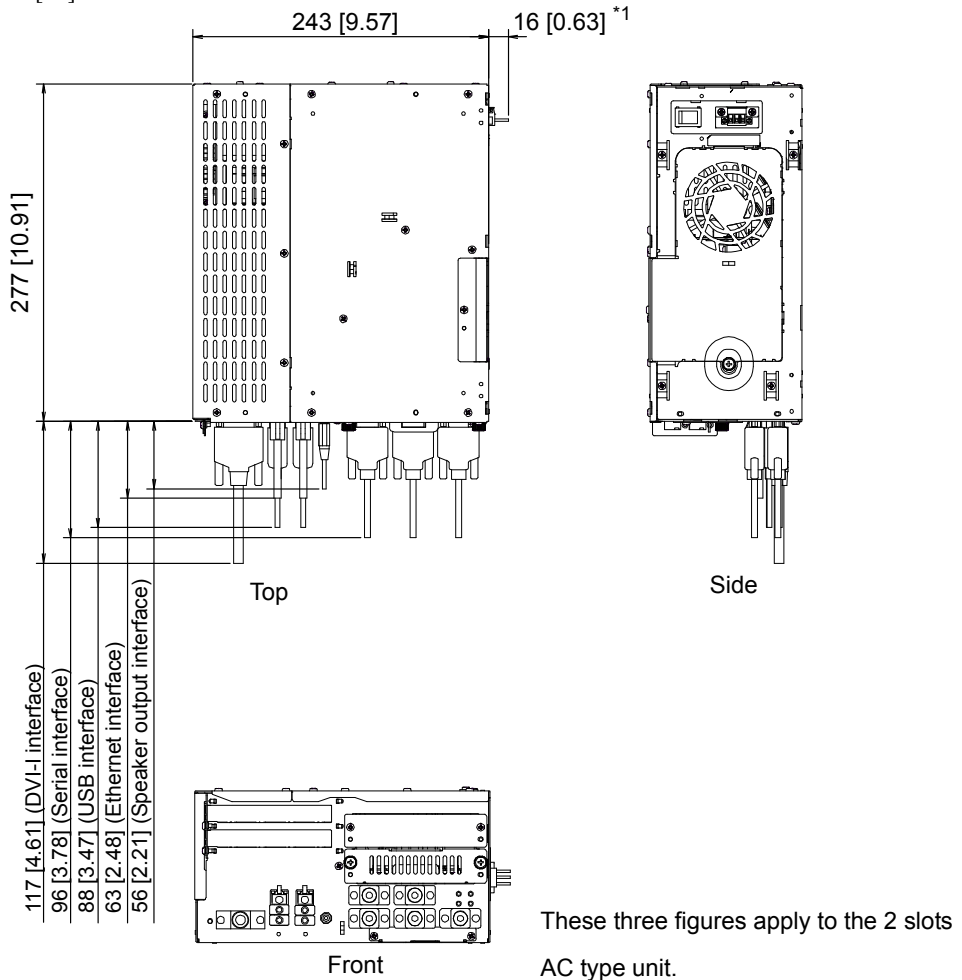

IMPORTANT

- All the above values are designed to allow for bends in the cable. The dimensions given here are representative values depending on the type of connection cable used. Therefore, they are all intended for reference only.

*1 The measurement in the figure above is the distance the cable connector extends from the outside of the control box when the AC power supply connector (straight) is used. Measurements when using other power supply connectors are shown below.

	Power Connector	Distance
Supplied	AC type (Straight Spring) CA7-ACCNL-01 by Pro-face	16mm [0.63in.]
	DC type (Straight Spring) CA7-DCCNL-01 by Pro-face	28mm [1.1in.]
Optional	AC type (Right-angle Spring) CA7-ACCNLR-01 by Pro-face	14mm [0.55in.]
	DC type (Right-angle Spring) CA5-DCCNL-01 by Pro-face	17mm [0.67in.]

4.1.4 Dimensions of the Screw Holes

Use the following dimension drawings to drill the attachment bracket's attachment screw holes in the installation panel. Use M4 size screws.

Unit: mm [in.]

◆ Horizontal mounting

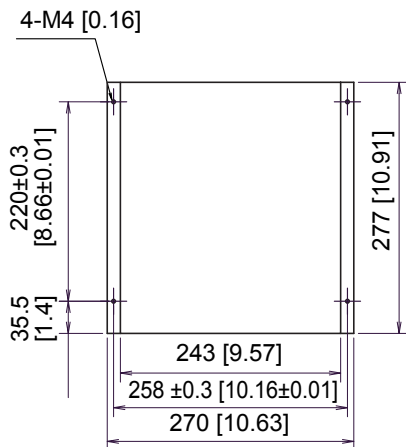

◆ Vertical mounting

NOTE

- When DVD drive unit is installed, the dimensions for Vertical mounting are different.

SEE →

■ Dimension of the Screw Holes (page 7-6)

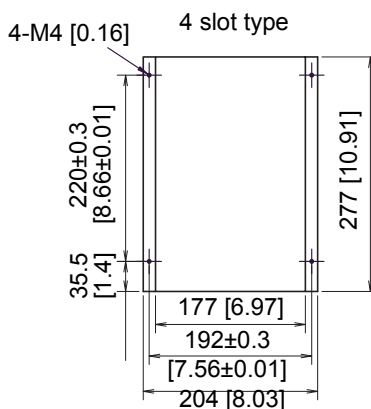
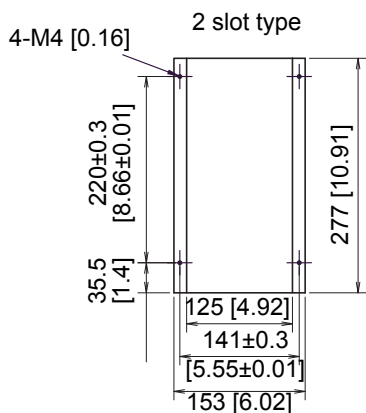

◆ Wall mounting

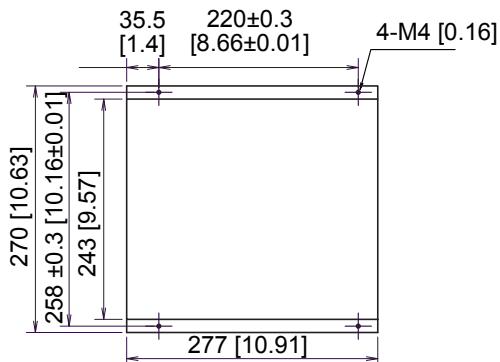

4.2 PL-3600T Series

4.2.1 Dimensions of the 2 slot Unit (Installation fasteners attached)

Unit: mm [in.]

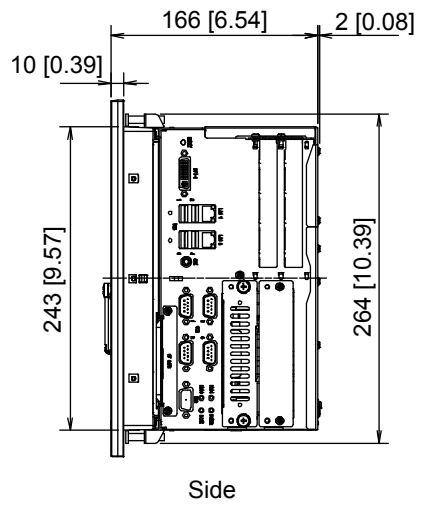
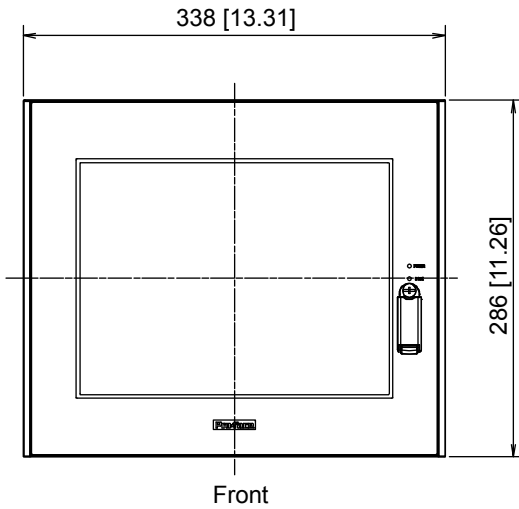
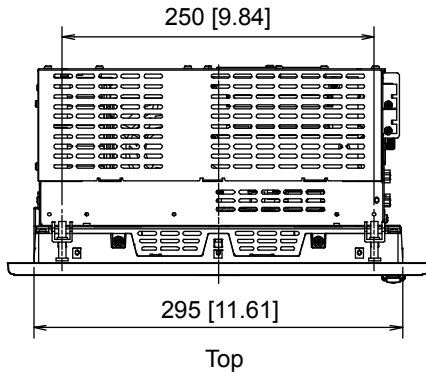

4.2.2 Dimensions of the 4 slot Unit (Installation fasteners attached)

Unit: mm [in.]

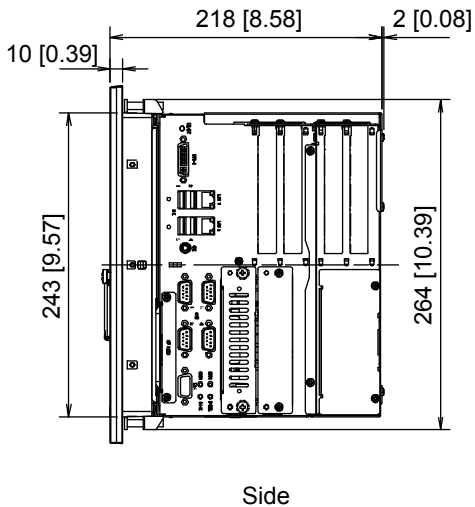
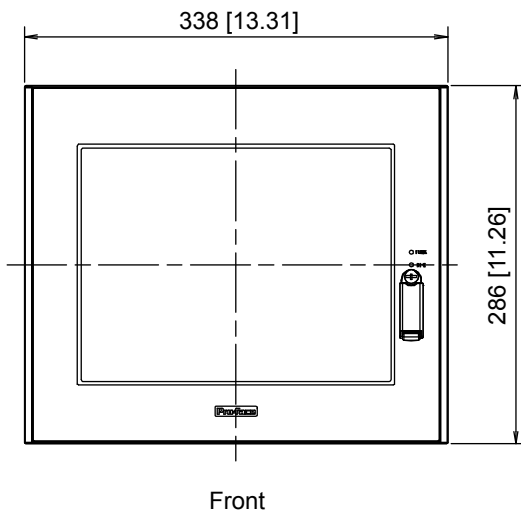
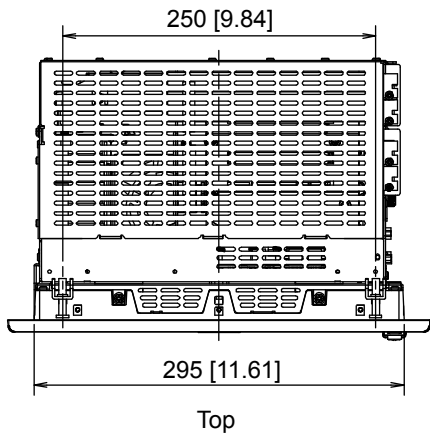

4.2.3 Cable Attached Dimensions

Unit: mm [in.]

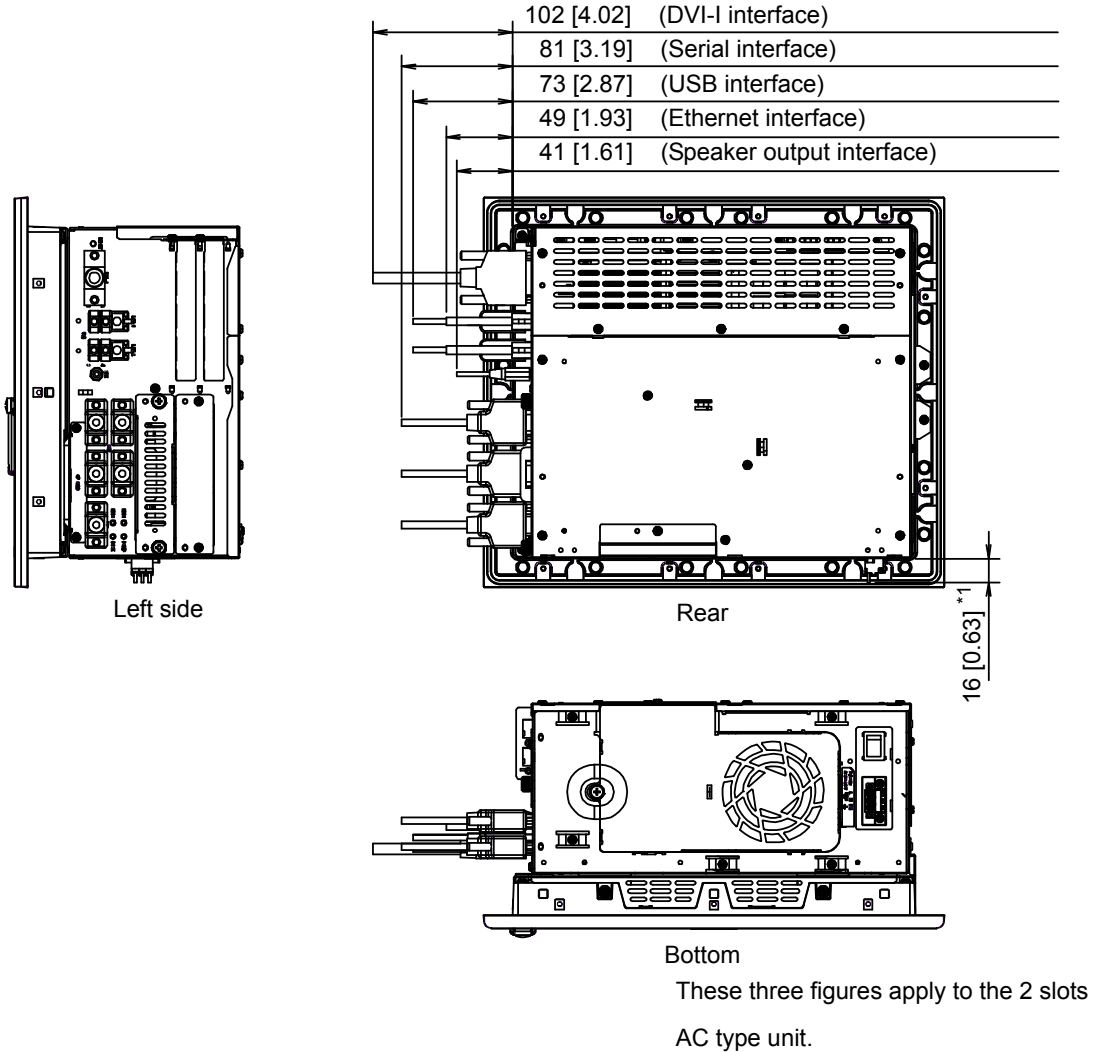

IMPORTANT

- All the above values are designed to allow for bends in the cable. The dimensions given here are representative values depending on the type of connection cable used. Therefore, they are all intended for reference only.

*1 This measurement is from the panel cut opening when the AC power supply connector (straight) is used. When a DC power supply connector is used, the measurement is 28mm [1.10in.].

4.2.4 Panel Cut Dimensions

Unit: mm [in.]

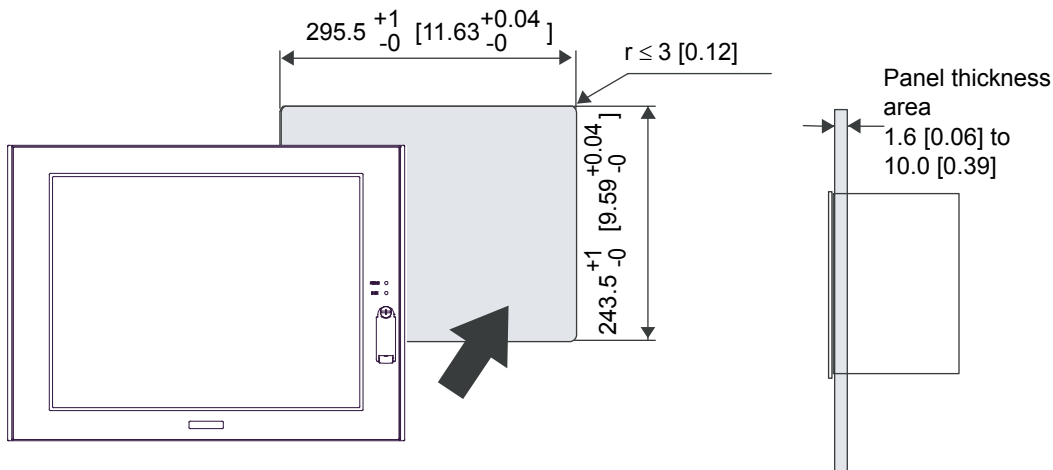

NOTE

- Please read "5.1 Installation (page 5-2)" before designing the Panel Cut.

4.2.5 Installation Fasteners

Unit: mm [in.]

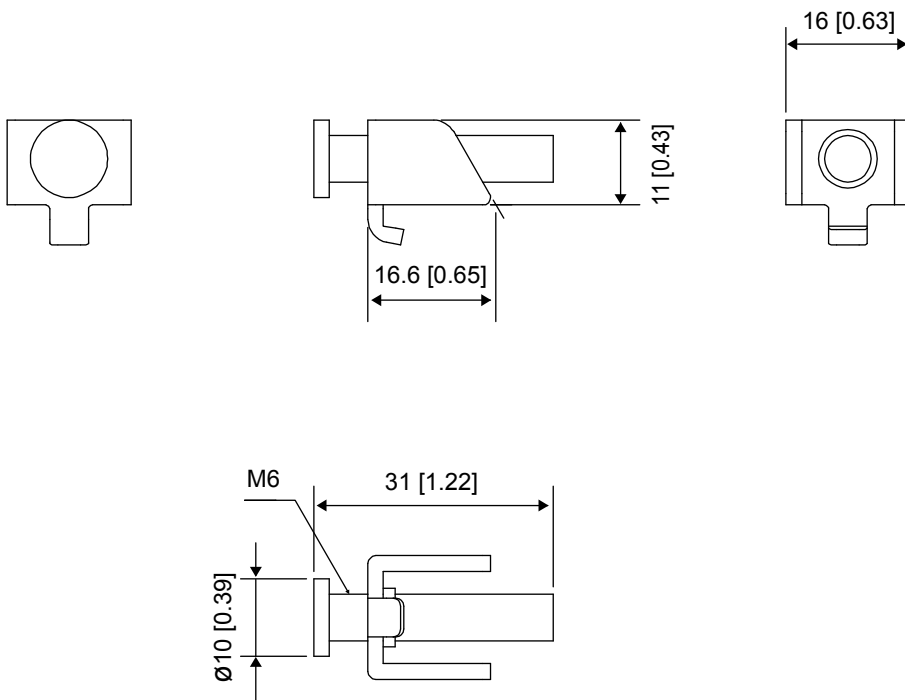

4.3 PL-3600K Series

4.3.1 Dimensions of the 2 slot Unit (Installation fasteners attached)

Unit: mm [in.]

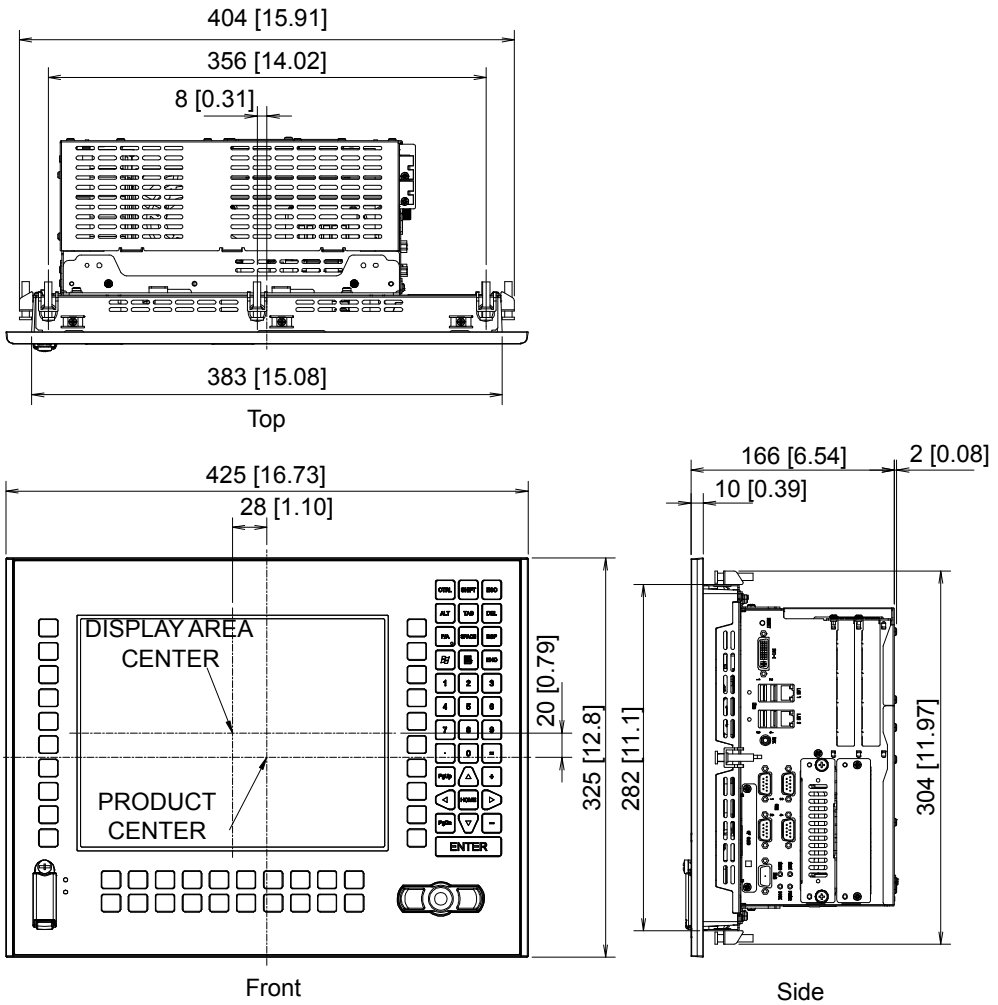

4.3.2 Dimensions of the 4 slot Unit (Installation fasteners attached)

Unit: mm [in.]

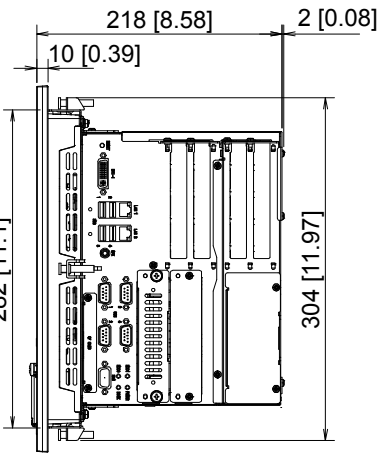
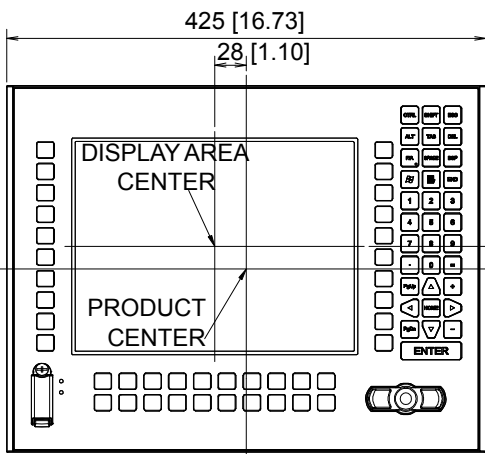
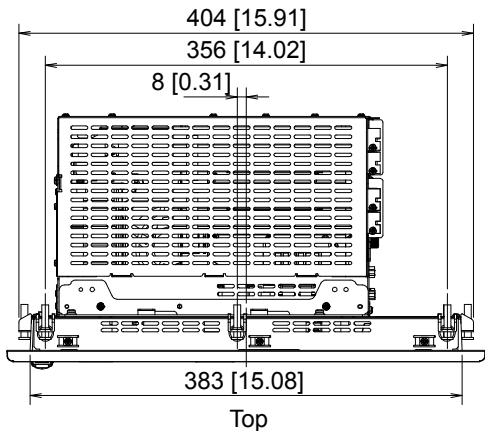

Front

Side

4.3.3 Cable Attached Dimensions

Unit: mm [in.]

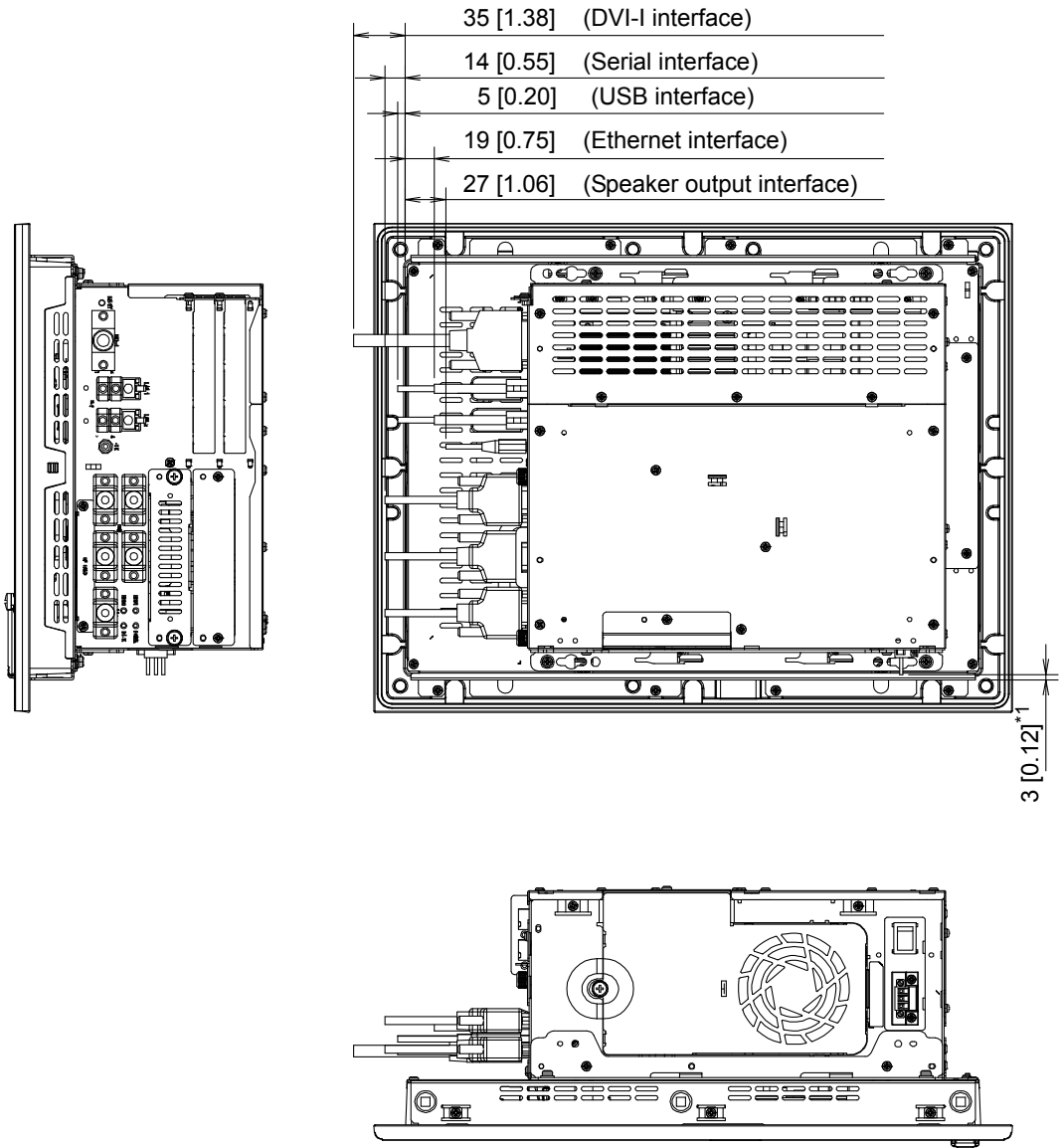

These three figures apply to the 2 slots AC type unit.

IMPORTANT

- All the above values are designed to allow for bends in the cable. The dimensions given here are representative values depending on the type of connection cable used. Therefore, they are all intended for reference only.

*1 When the AC power supply connector (straight) is used, this is the clearance between the cable connector extends and the panel cut opening. When a DC power supply connector is used, it will project 9mm [0.35in.] beyond the panel cut opening.

4.3.4 Panel Cut Dimensions

Unit: mm [in.]

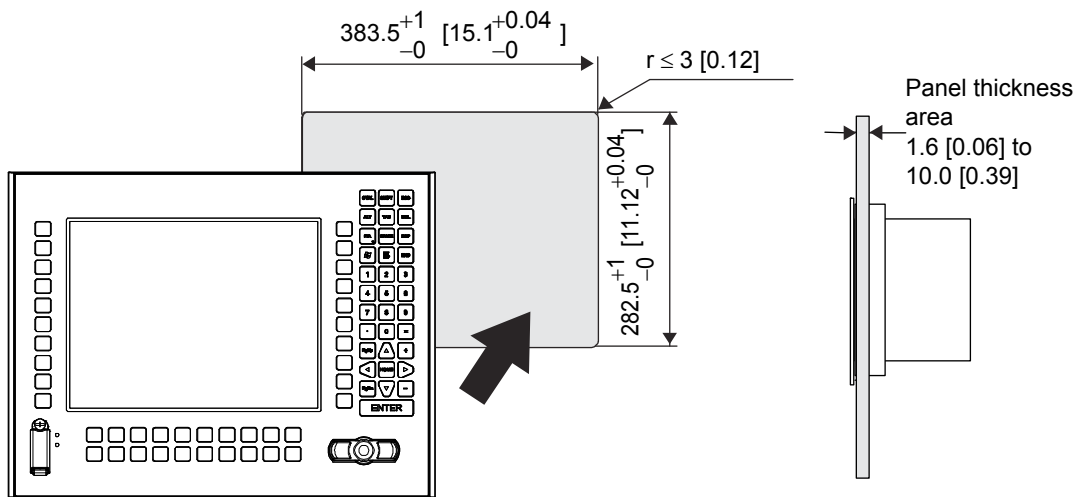

NOTE

- Please read "5.1 Installation (page 5-2)" before designing the Panel Cut.
- When replacing the Xycom Automation 3612KPM/4612KPM with the PL-3600K Series, it is possible to attach the PL-3600K Series without changing the panel cut dimensions by removing the attachments indicated in the diagram below. Remove the seven screws from the top and bottom of the unit, and then remove the attachments.

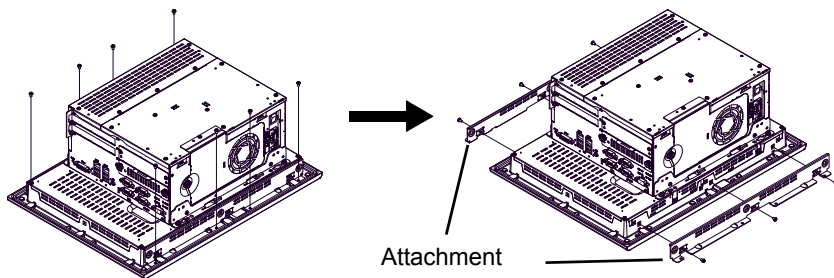

- Panel cut dimensions when the attachments have been removed are as indicated below.

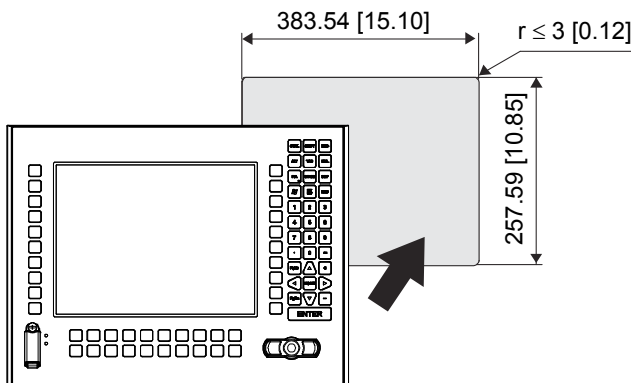

4.3.5 Installation Fasteners

Unit: mm [in.]

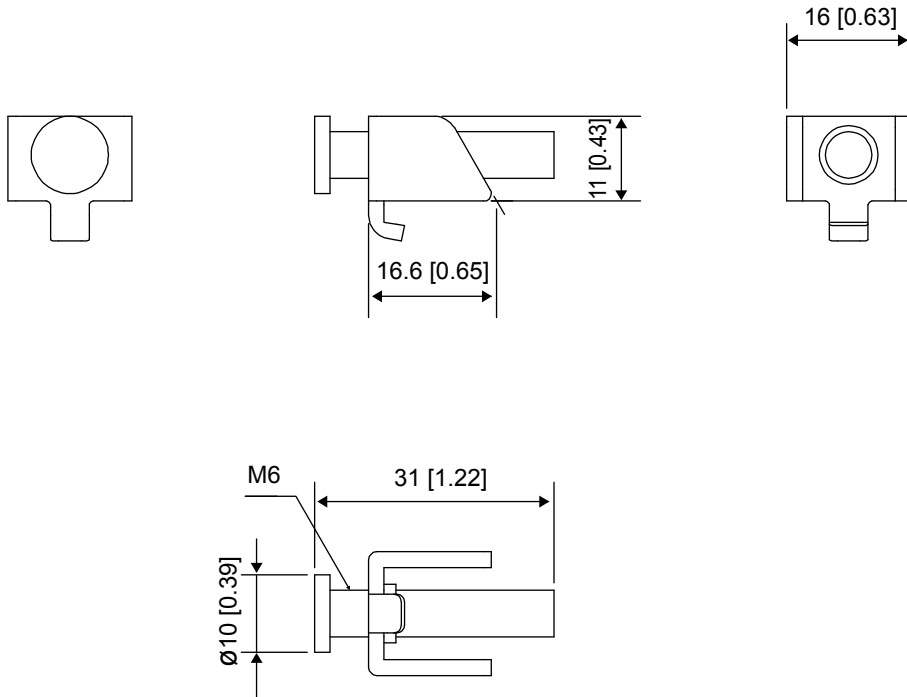

4.4 PL-3700T Series

4.4.1 Dimensions of the 2 slot Unit (Installation fasteners attached)

Unit: mm [in.]

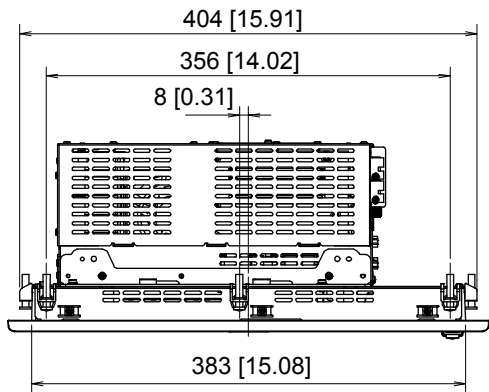

Top

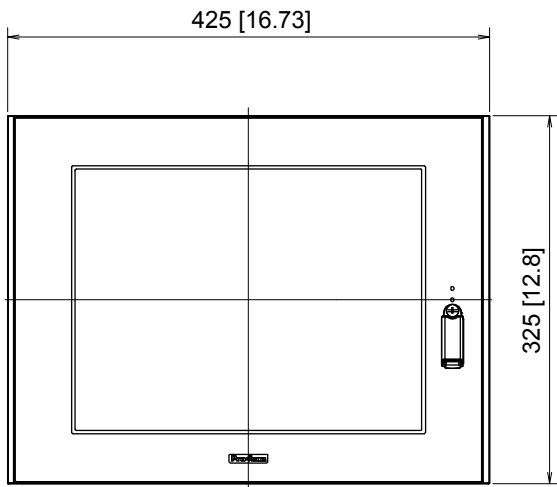

Front

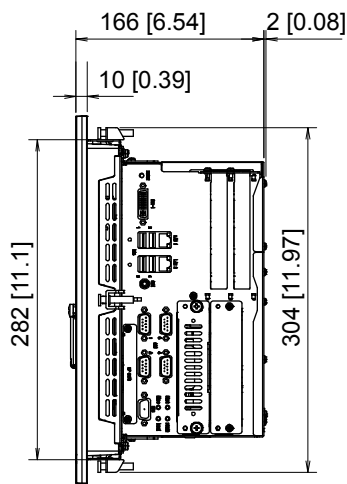

Side

4.4.2 Dimensions of the 4 slot Unit (Installation fasteners attached)

Unit: mm [in.]

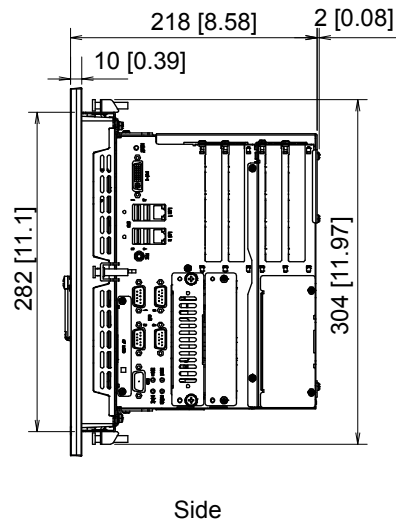
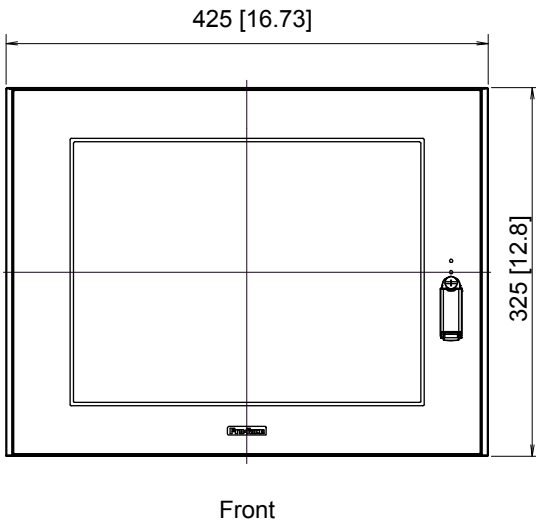
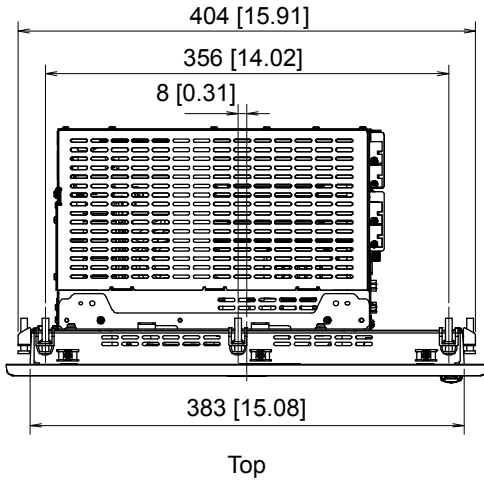

4.4.3 Cable Attached Dimensions

Unit: mm [in.]

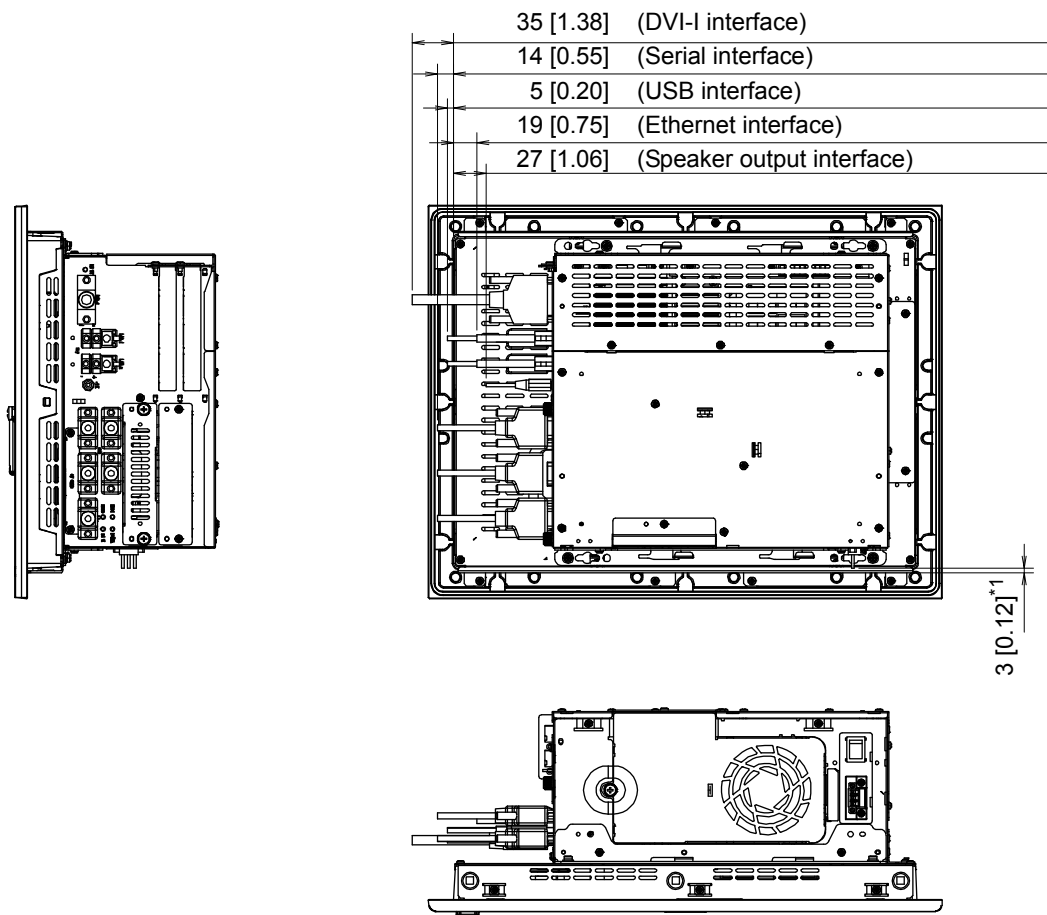

These three figures apply to the 2 slots
AC type unit.

IMPORTANT

- All the above values are designed to allow for bends in the cable. The dimensions given here are representative values depending on the type of connection cable used. Therefore, they are all intended for reference only.

*1 When the AC power supply connector (straight) is used, this is the clearance between the cable connector extends and the panel cut opening. When a DC power supply connector is used, it will project 9mm [0.35in.] beyond the panel cut opening.

4.4.4 Panel Cut Dimension

Unit: mm [in.]

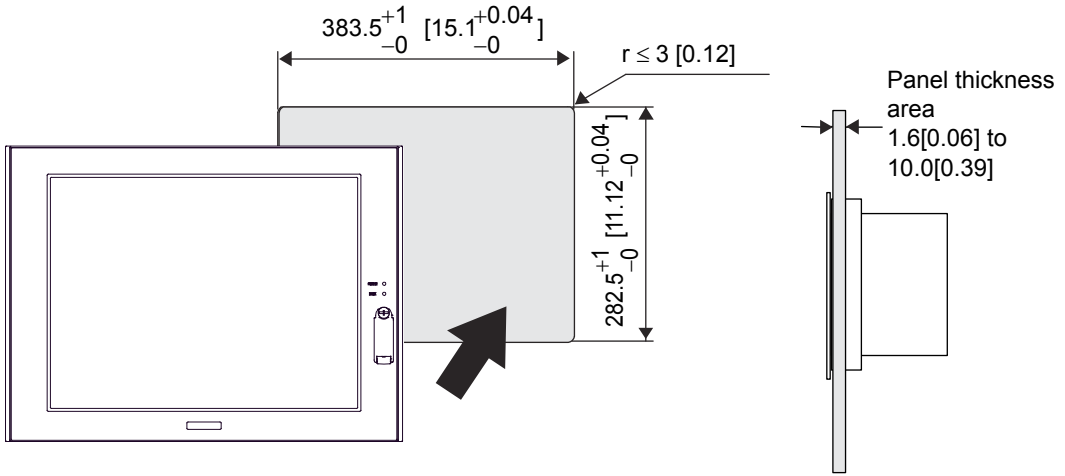

NOTE

- Please read "5.1 Installation (page 5-2)" before designing the Panel Cut.

4.4.5 Installation Fasteners

Unit: mm [in.]

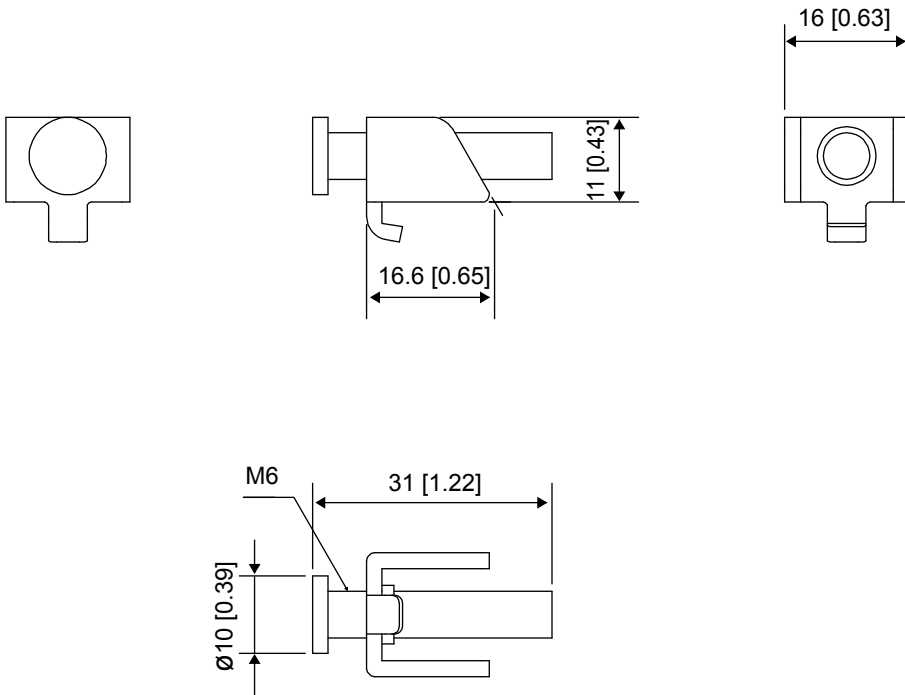

4.5 PL-3700K Series

4.5.1 Dimensions of the 2 slot Unit (Installation fasteners attached)

Unit: mm [in.]

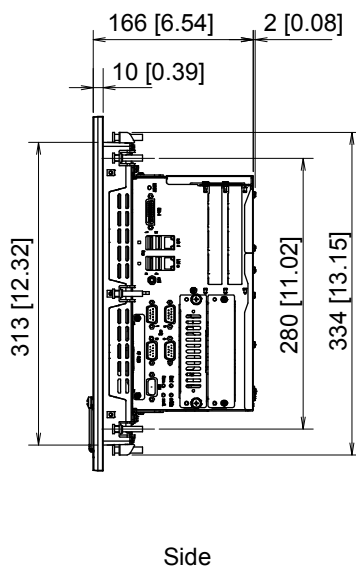
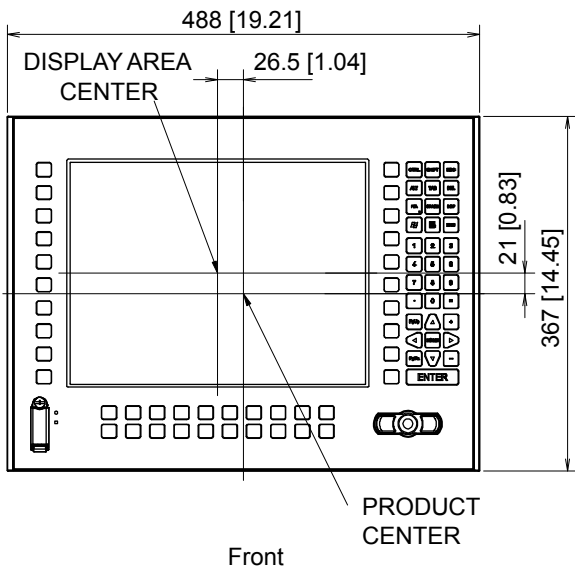
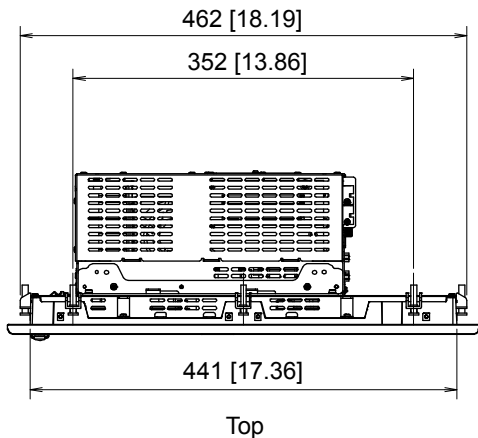

4.5.2 Dimensions of the 4 slot Unit (Installation fasteners attached)

Unit: mm [in.]

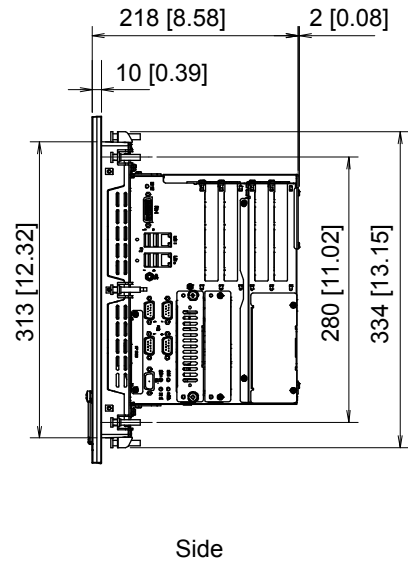
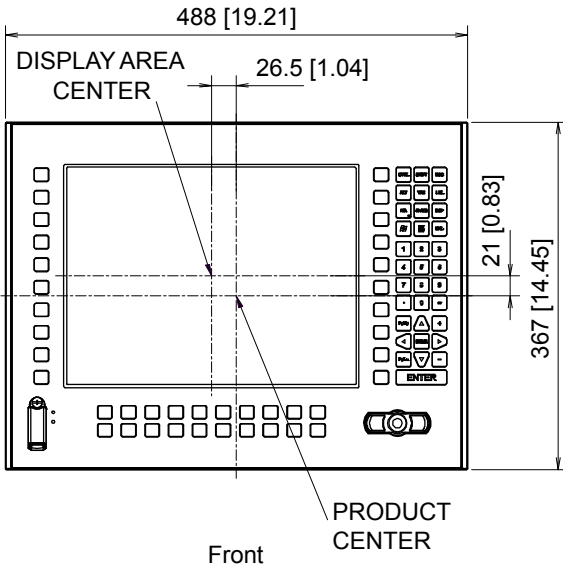
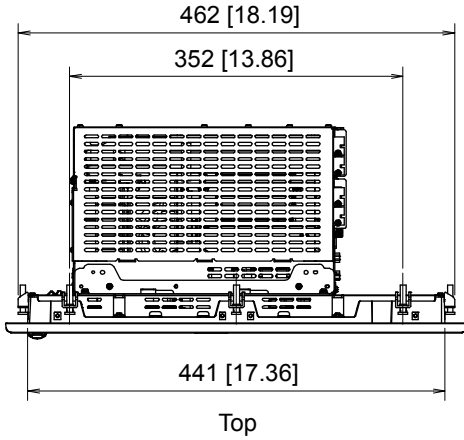

4.5.3 Cable Attached Dimensions

Unit: mm [in.]

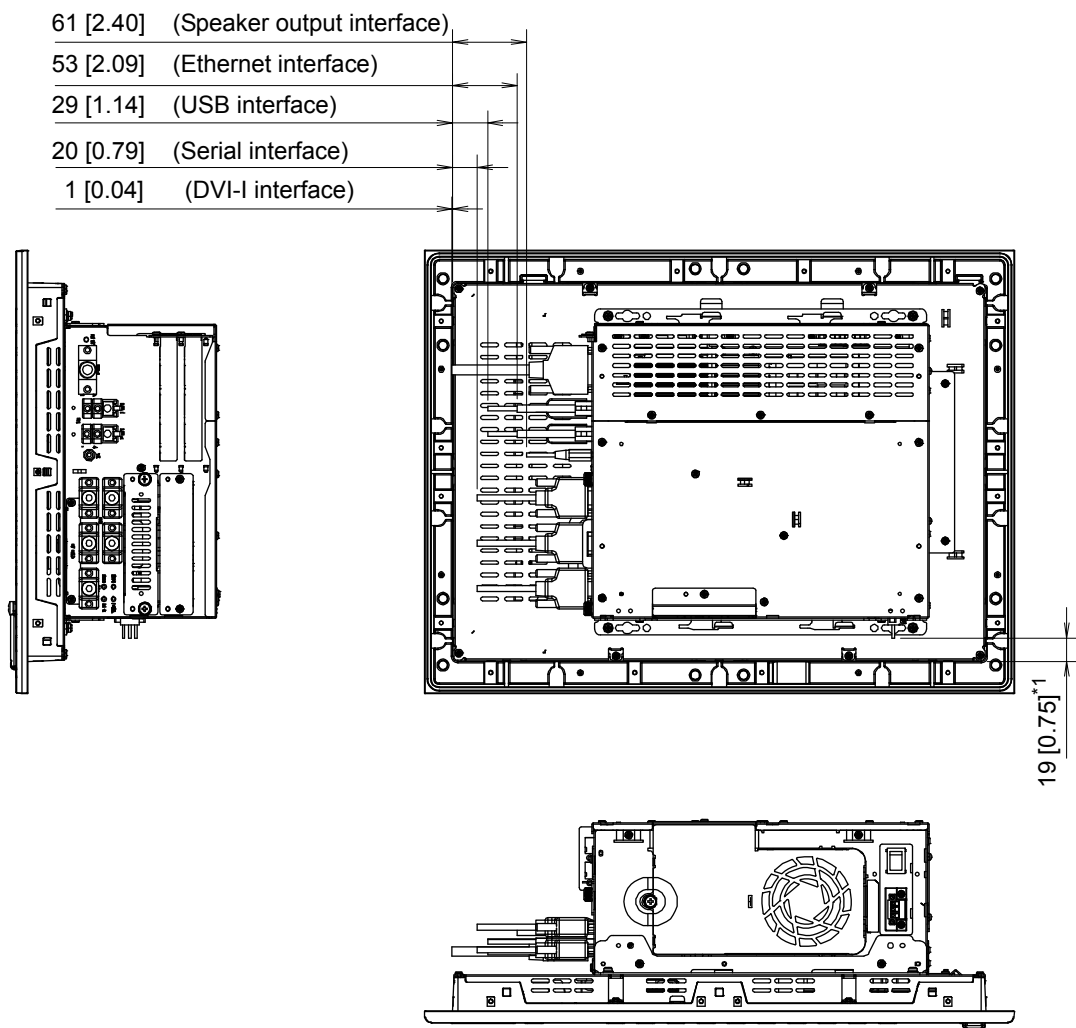

These three figures apply to the 2 slots AC type unit.

IMPORTANT

- All the above values are designed to allow for bends in the cable. The dimensions given here are representative values depending on the type of connection cable used. Therefore, they are all intended for reference only.

*1 When the AC power supply connector (straight) is used, this is the clearance between the cable connector extends and the panel cut opening. When a DC power supply connector is used, the measurement is 7mm [0.28in.] beyond the panel cut opening.

4.5.4 Panel Cut Dimension

Unit: mm [in.]

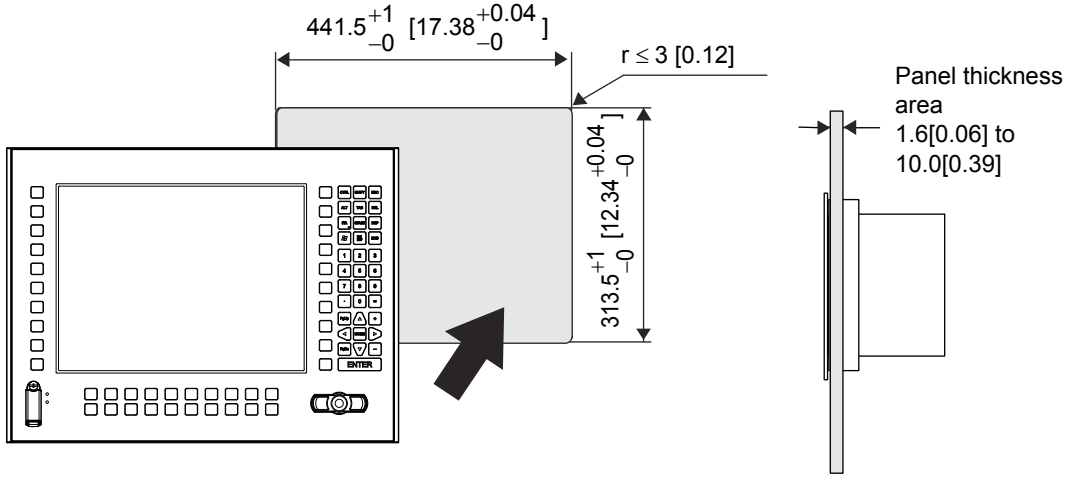

NOTE

- Please read "5.1 Installation (page 5-2)" before designing the Panel Cut.

4.5.5 Installation Fasteners

Unit: mm [in.]

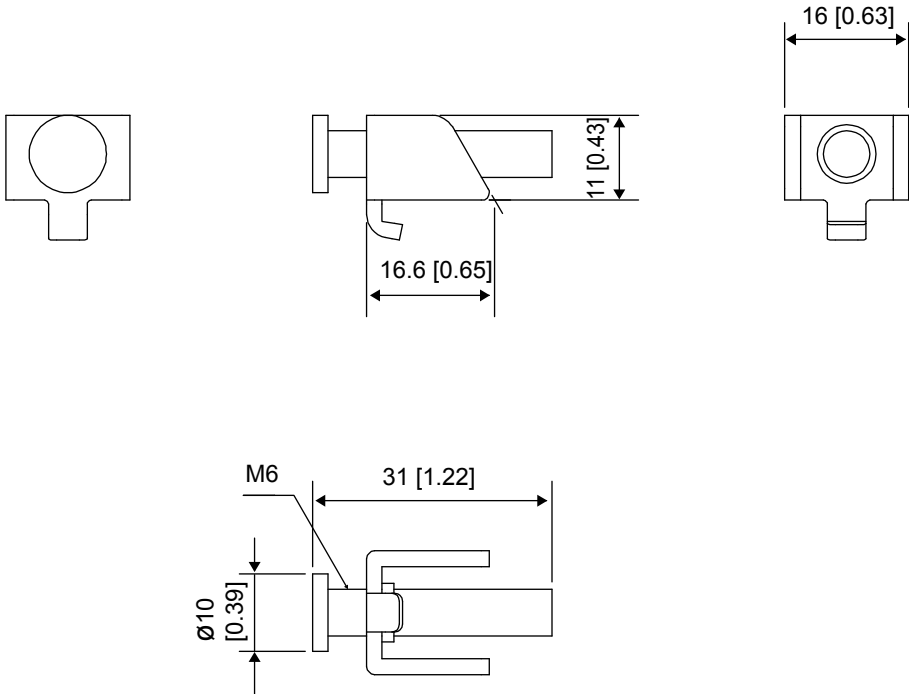

4.6 PL-3900T Series

4.6.1 Dimensions of the 2 slot Unit (Installation fasteners attached)

Unit: mm [in.]

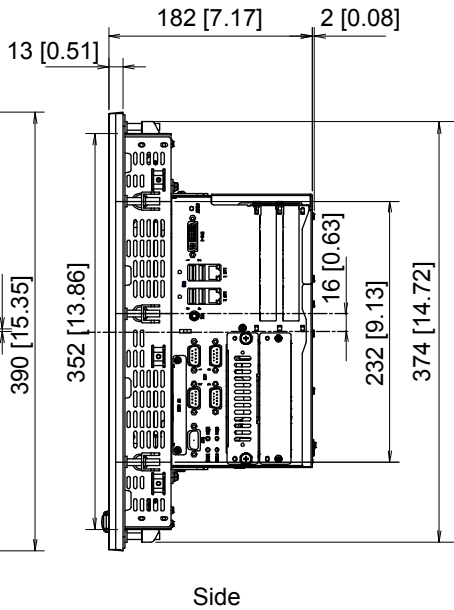
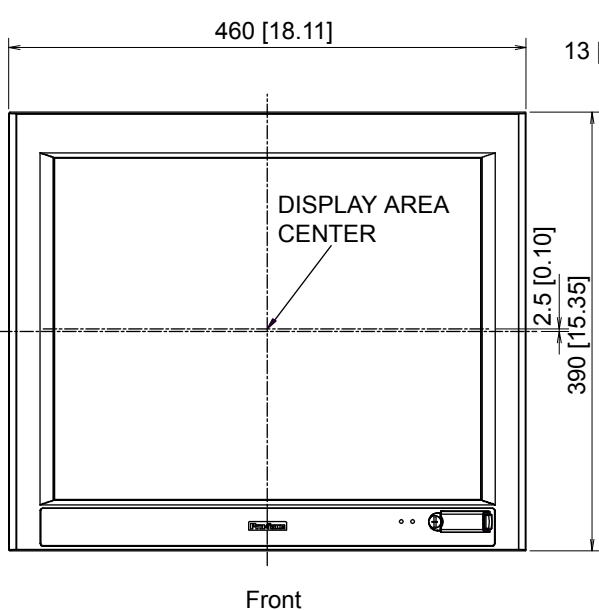
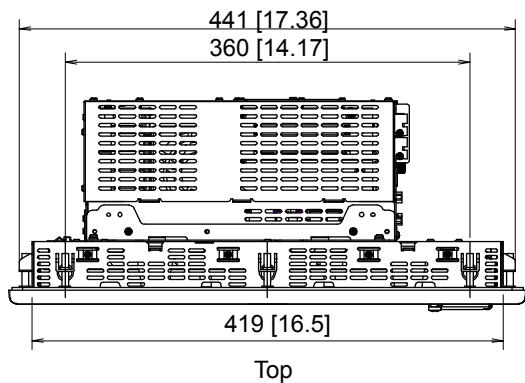

4.6.2 Dimensions of the 4 slot Unit (Installation fasteners attached)

Unit: mm [in.]

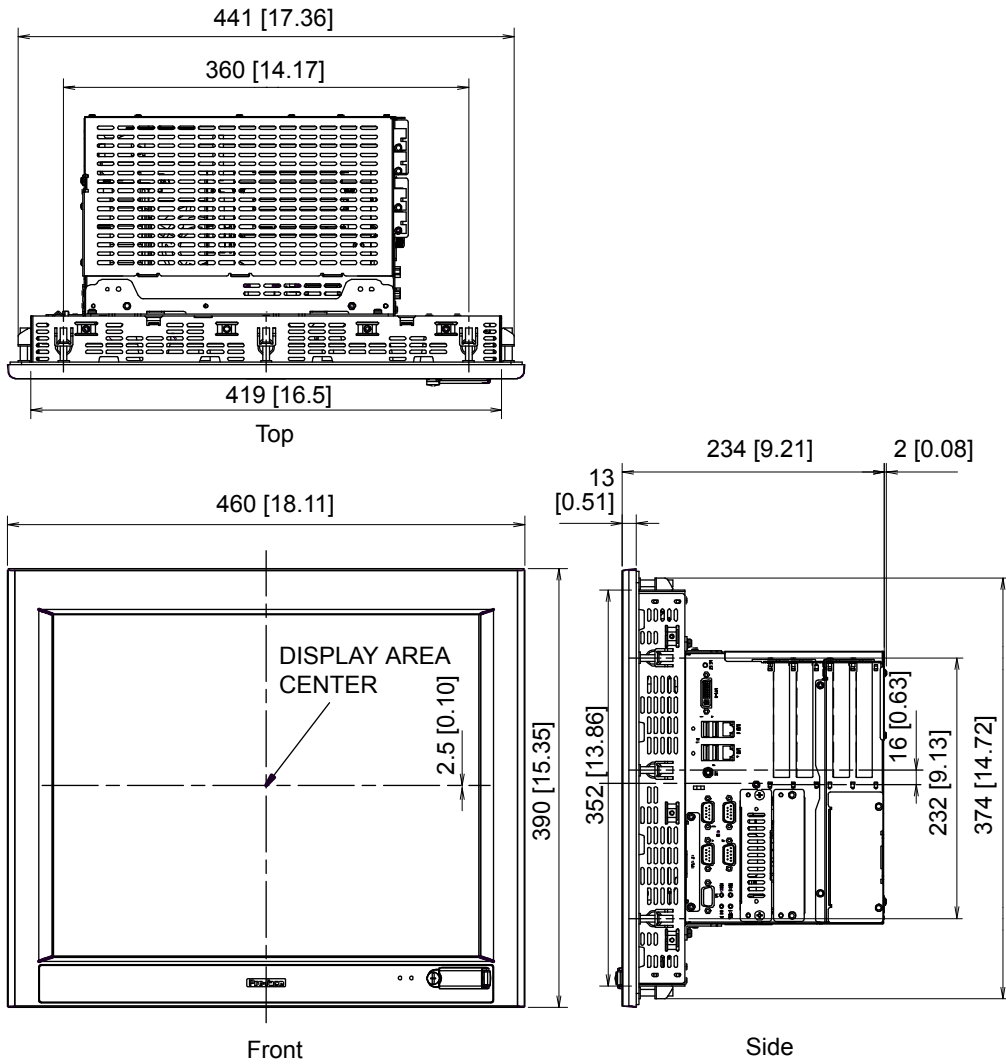

4.6.3 Cable Attached Dimensions

Unit: mm [in.]

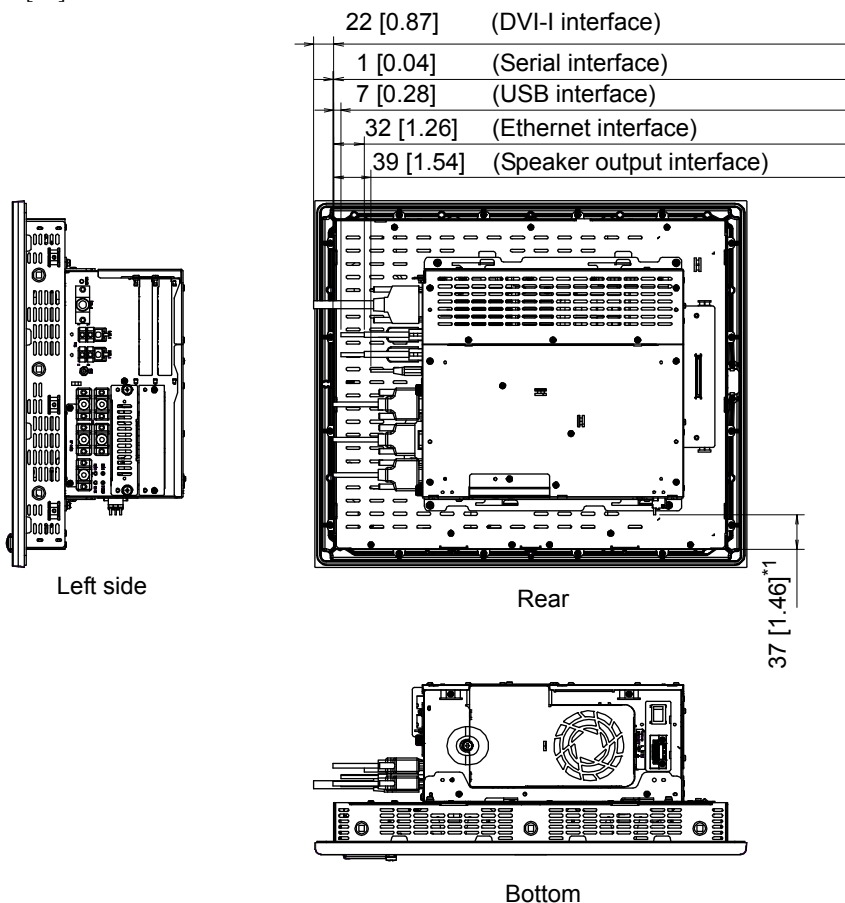

These three figures apply to the 2 slots
AC type unit.

IMPORTANT

- All the above values are designed to allow for bends in the cable. The dimensions given here are representative values depending on the type of connection cable used. Therefore, they are all intended for reference only.

*1 When the AC power supply connector (straight) is used, this is the clearance between the cable connector extends and the panel cut opening. When a DC power supply connector is used, the measurement is 25mm [0.98in.] beyond the panel cut opening.

4.6.4 Panel Cut Dimensions

Unit: mm [in.]

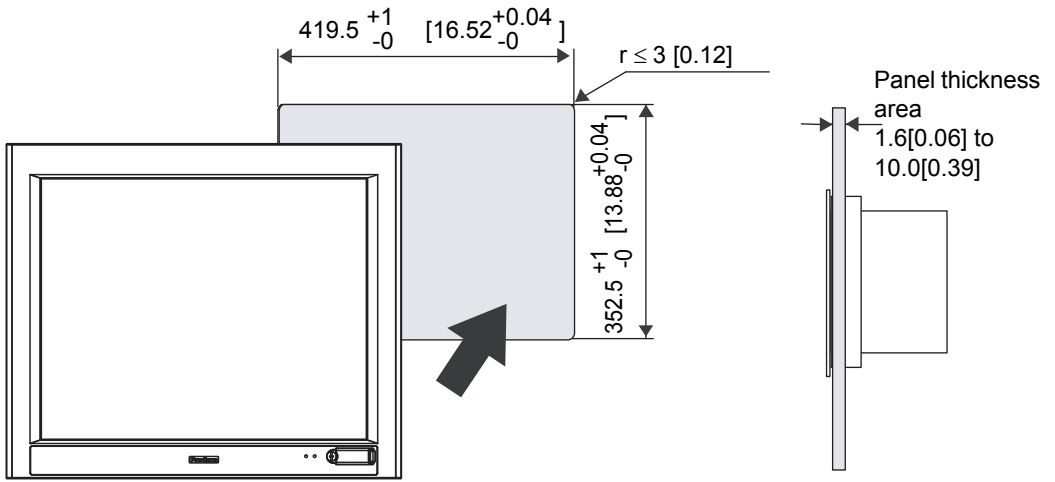

NOTE

- Please read "5.1 Installation (page 5-2)" before designing the Panel Cut.

4.6.5 Installation Fasteners

Unit: mm [in.]

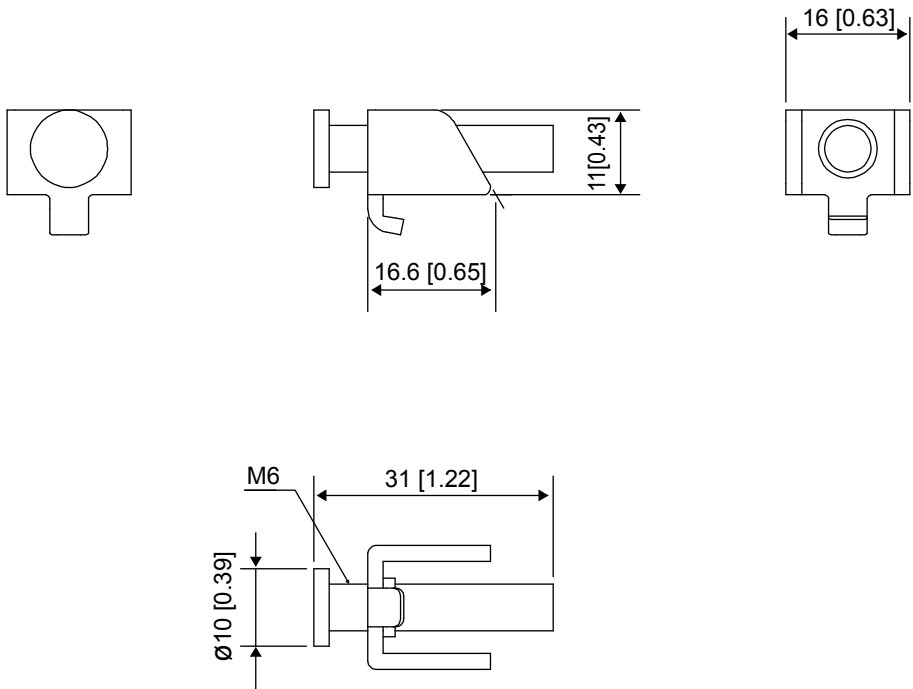

5

Installation and Wiring

1. Installation
2. Installing/removing the front module and the control box
3. Peripheral Device Installation
4. Wiring Precautions

This chapter describes the installation of the PL unit and its peripheral devices as well as the power cord wiring in the unit.

5.1 Installation

This section describes the procedures and precautions for installing the PL units.

5.1.1 PL-3000B Series

■ Installation Requirements

- The PL unit can be mounted horizontally or vertically on a panel as well as attached to a wall. To prevent abnormally high temperatures from occurring inside the PL unit, mount the unit on a horizontal panel or attach it to a vertical wall.

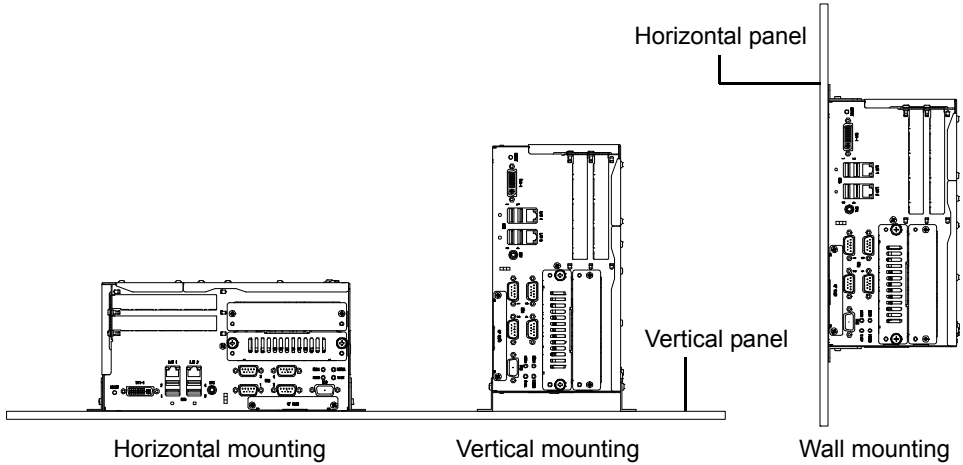

NOTE

- When PL-3000B Series is mounted vertically, a right-angle power connector is recommended.

SEE → 5.4.1 Connecting the Power Cord (page 5-23)

- For easier maintenance, operation, and improved ventilation, be sure to install the PL at least 50mm [1.97in.] away from adjacent structures and other equipment. 120mm [4.72in.] space (minimum) is necessary at the front for cable curve.

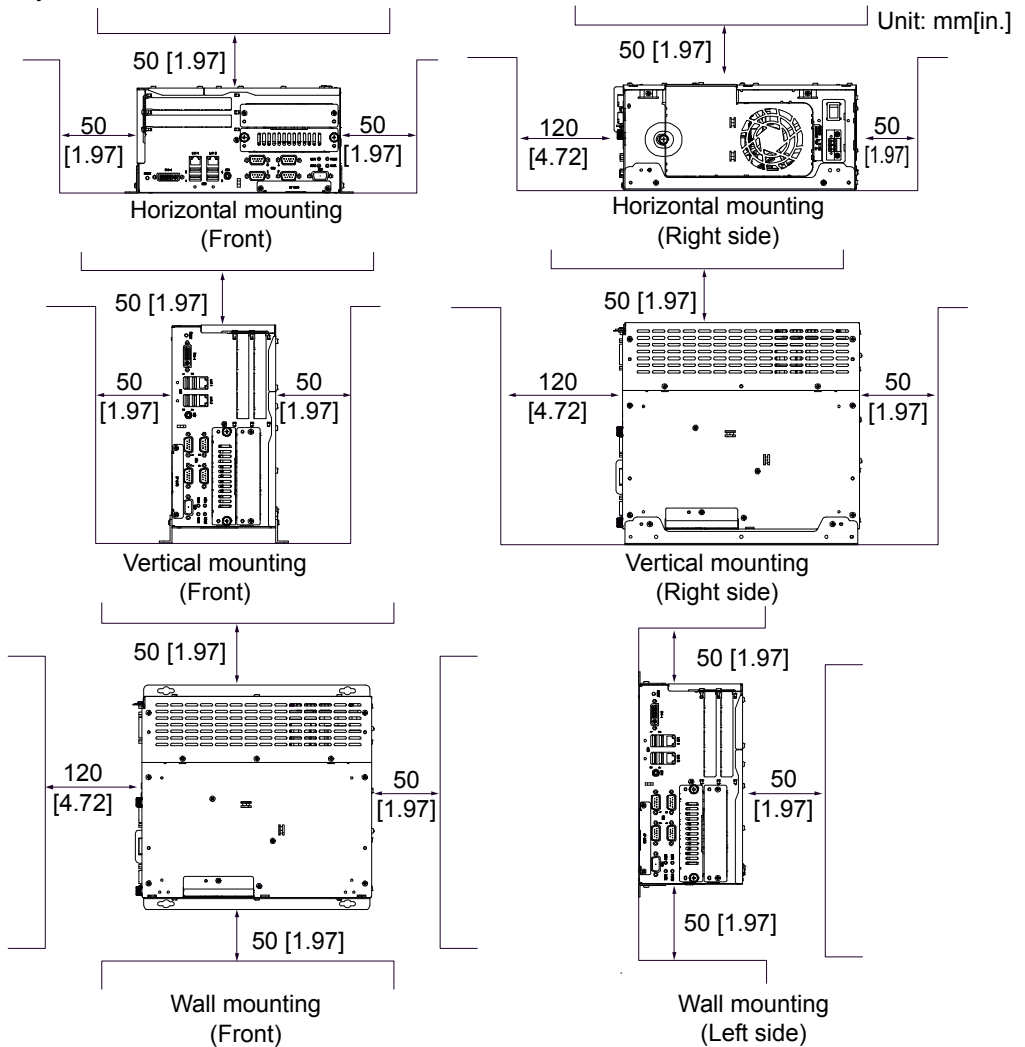

- Be sure that the surrounding air temperature and the ambient humidity are within their specified ranges. Check the surrounding air temperature 30mm [1.18in.] away from the main unit.

Ex.: Horizontal mounting

Unit: mm[in.]

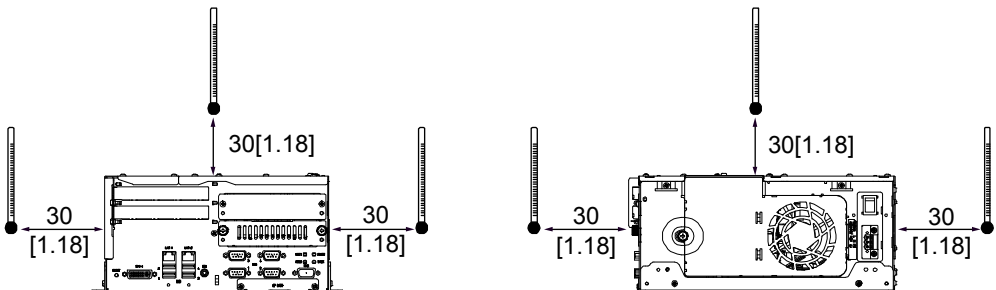

- Be sure that heat from surrounding equipment does not cause the PL to exceed its standard operating temperature.

■ Creating Screw Holes

Create the correct sized openings required to install the PL, using the installation dimensions given.

SEE → 4.1.4 Dimensions of the Screw Holes (page 4-7)

■ Installing the PL

- (1) Attach installation fasteners with the accompanying four M3 screws to the PL unit.

The torque should be 0.5 to 0.6 N•m.

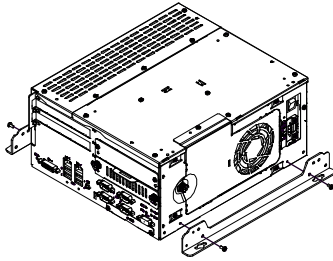

Horizontal mounting or wall mounting

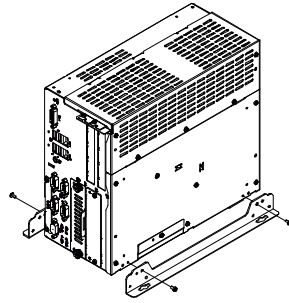

Vertical mounting

- (2) Attach the PL unit to the board with M4 screws (not supplied): First, tighten the screws temporarily on the board; mount installation fasteners temporarily onto the screws; and then tighten the screws until the PL unit is securely fixed. The torque should be 1.0 to 1.2 N•m.

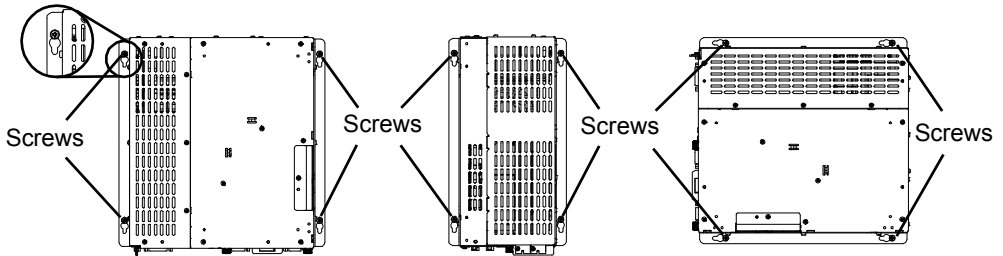

Horizontal mounting

Vertical mounting

Wall mounting

IMPORTANT

- Depending on the panel's material and design, the panel's installation surface may need to be strengthened. If high levels of vibration are expected and the PL unit's installation surface (i.e. an operation panel's door, etc.) can move (i.e. open or close) due consideration should be given to the PL unit's weight.
- Determine the thickness of the panel in consideration of its material and strength as well as the environment in which the PL unit is used. The thickness must be 1.6mm [0.063in.] or more, considering the length of M4 screws.
- M4 screws are not included with the PL unit. Please prepare them by yourself.

5.1.2 PL-3600*/PL-3700*/PL-3900T Series

This section describes the procedures and precautions for installing the PL units.

■ Check the Installation Gasket's Seating

It is strongly recommended that you use the installation gasket, since it absorbs vibration in addition to repelling liquids.

For the gasket installation procedure, see "6.3 Replacing the Installation Gasket (page 6-5)".

SEE → 6.3 Replacing the Installation Gasket (page 6-5)

IMPORTANT

- Before installing the PL into a cabinet or panel, check that the installation gasket is securely attached to the unit.
- A gasket which has been used for a long period of time may have scratches or dirt on it, and could have lost much of its dust and drip resistance. Be sure to change the gasket periodically (or when scratches or dirt become visible).

■ Creating a Panel Cut

Create the correct sized opening required to install the PL, using the installation dimensions given.

SEE → *PL-3600T Series*
 4.2.4 Panel Cut Dimensions (page 4-11)
PL-3600K Series
 4.3.4 Panel Cut Dimensions (page 4-15)
PL-3700T Series
 4.4.4 Panel Cut Dimension (page 4-20)
PL-3700K Series
 4.5.4 Panel Cut Dimension (page 4-24)
PL-3900T Series
 4.6.4 Panel Cut Dimensions (page 4-28)

NOTE

- Check that the installation panel or cabinet's surface is flat, in good condition and has no jagged edges.

IMPORTANT

- Panel thickness should be from 1.6mm [0.06 in.] to 10.0mm [0.29 in.]. Even if panel thickness is within recommend range for "Panel Cut Dimensions", the panel could warp, depending on panel's material and installation location of PL or other devices. To prevent panel warpage, the installation surface may need to be strengthened.

■ Installation Requirements

- For easier maintenance, operation, and improved ventilation, be sure to install the PL at least 50mm [1.97in.] away from adjacent structures and other equipment. For the face to which the cable is connected, however, a space of 120mm [7.72in.] or more is necessary for cable curve.

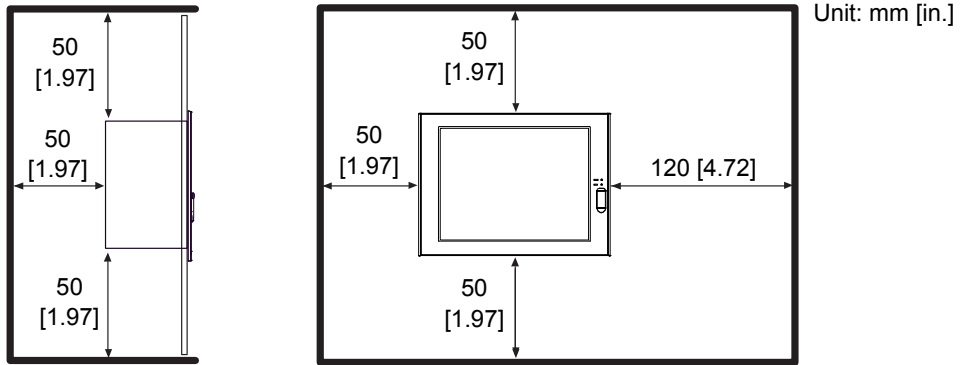

- Be sure that the ambient operation temperature and the ambient humidity are within their designated ranges. When installing the PL on the panel of a cabinet or enclosure, “Surrounding air temperature” indicates both the panel face and cabinet or enclosure’s internal temperature.

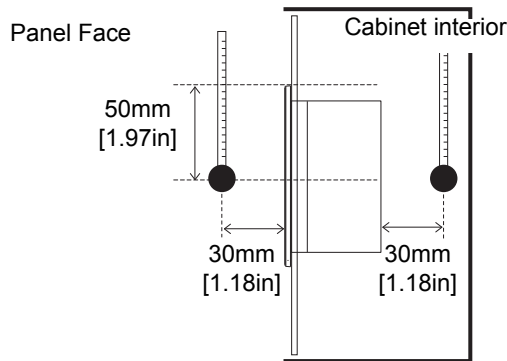

- Be sure that heat from surrounding equipment does not cause the PL to exceed its standard operating temperature.
- When installing the PL in a slanted panel, the panel face should not incline more than 30°.

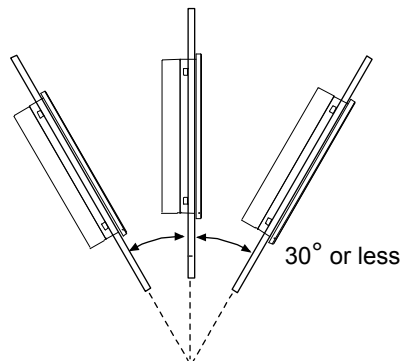

- When installing the PL in a slanted panel, and the panel face inclines more than 30°, the surrounding air temperature must not exceed 40°C. You may need to use forced air cooling (fan, A/C) to ensure the surrounding air temperature is 40°C or below.
- The PL Series unit does not support longitudinal mounting.

■ Installing the PL

IMPORTANT

- Before installing the PL unit on a panel, remove the control box from the front module and then set the internal switch setting.

SEE →

5.2 Installing/removing the front module and the control box (page 5-9)
 3.4 Internal Switches Specifications (page 3-16)

- (1) Insert the PL into the panel cut, as shown.

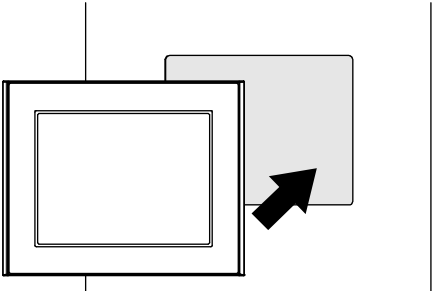

NOTE

- When replacing the Xycom Automation 3612KPM/4612KPM with the PL-3600K Series, remove the attachments from the PL-3600K Series in advance.

SEE →

4.3.4 Panel Cut Dimensions (page 4-15)

- (2) Insert each fastener's hook into the slot of the PL.

The number of the slots varies depending on the model.

- PL-3600T Series: 4 slots
- PL-3600K/3700T Series: 8 slots
- PL-3700K/3900T Series: 12 slots

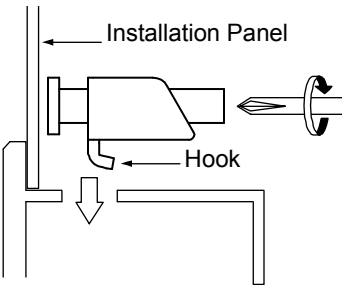

Locations of the 8 slots

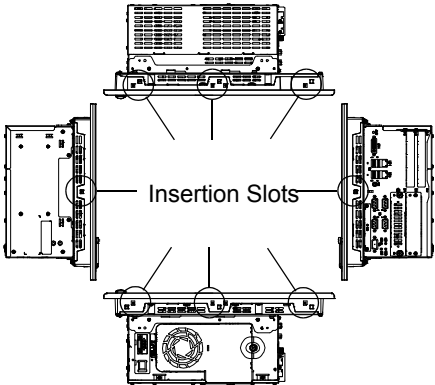

Locations of the 4 slots

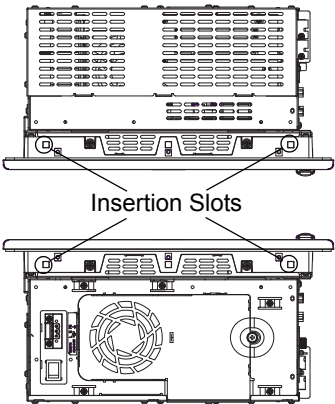

Locations of the 12 slots

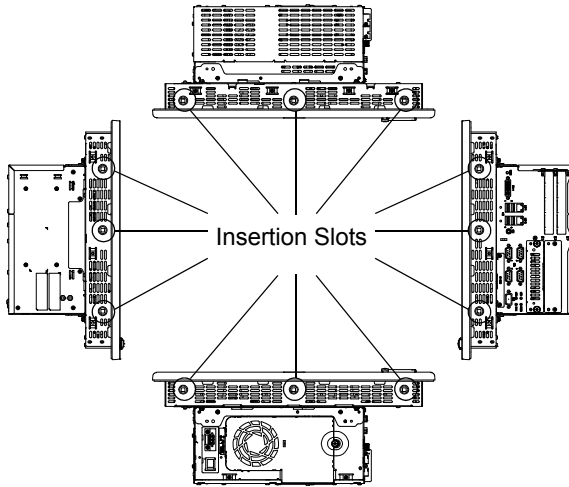

(3) Insert each of the fasteners, as shown. Be sure to pull the fastener back until it is flush with the rear of the attachment hole.

(4) Use a Phillips screwdriver to tighten each fastener screw and secure the PL in place.

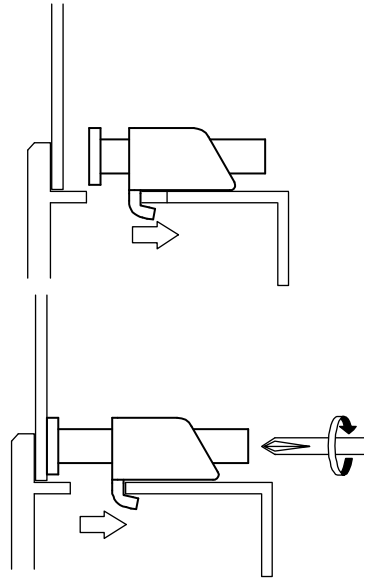

IMPORTANT

- Tightening the screws with too much force can damage the PL unit's plastic case.
- The torque required to tighten these screws is 0.8 N•m.

5.2 Installing/removing the front module and the control box

Before operating the internal switches or replacing the backlight or the batteries for clock data backup, remove the control box from the front module.

⚠ WARNING

❗ Be sure to confirm that power is not being supplied to the PL unit before installing or removing the front module and the control box. Failure to do so can result in an electric shock.

IMPORTANT

- In the Soft OFF status, power is supplied to some of the circuits even when the screen of the front module is blank. Before removing the control box, be sure to confirm that its power supply switch is OFF or its power cable is not connected.
- Use a screwdriver to loosen or tighten the screws. Be sure not to tighten screws too tightly, since it may damage the unit.
- When removing or replacing screws, be careful that they do not fall inside the PL unit's chassis.

5.2.1 PL-3600T Series

■ Removing the front module and the control box

Remove the control box from the front module with the following steps:

- (1) Unscrew the attachment screw securing the flexible cable cover and remove the cover.

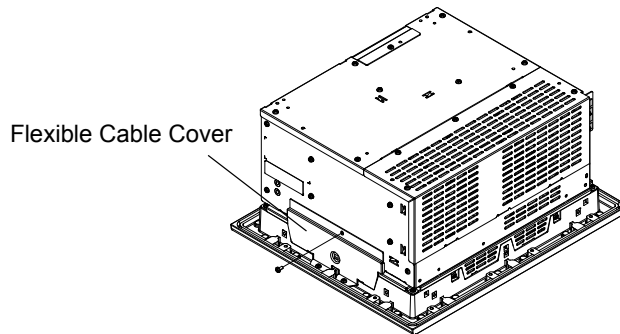

- (2) Disconnect the flexible cable.

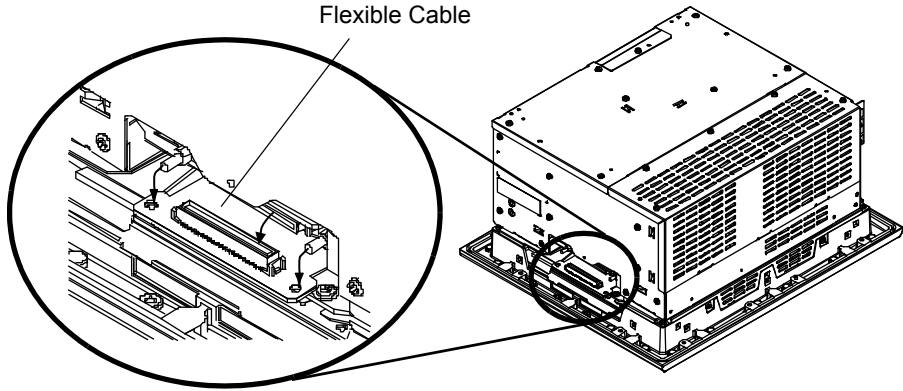

- (3) Unscrew the four (4) attachment screws on the top and bottom faces of the front module.

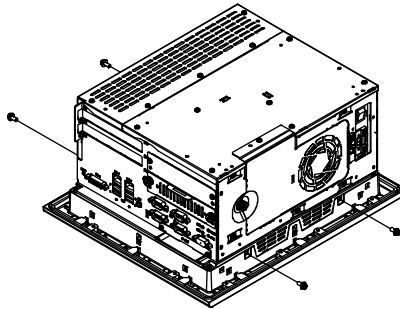

- (4) Remove the control box from the front module.

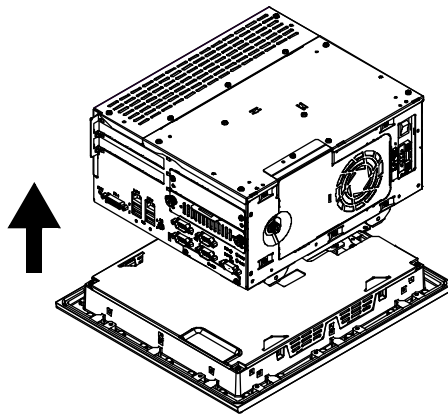

■ Installing the control box on the front module

Install the control box on the front module in the reverse order of the removal steps of (1) to (4).

The necessary torque is 0.5N•m to 0.6N•m in every step.

5.2.2 PL-3600K/3700*/3900T Series

■ Removing the front module and the control box

Remove the control box from the front module with the following steps:

- (1) Unscrew the attachment screws securing the flexible cable cover and remove the cover.

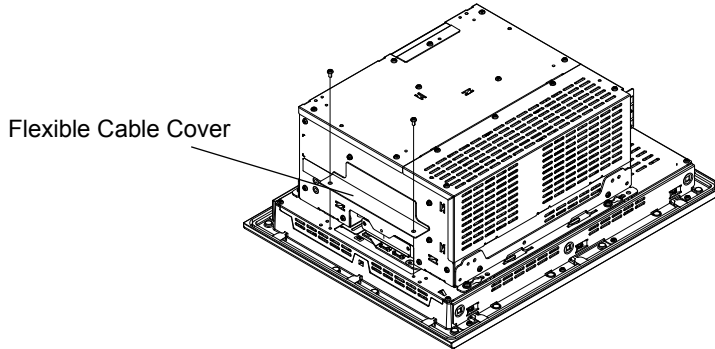

- (2) Disconnect the flexible cable.

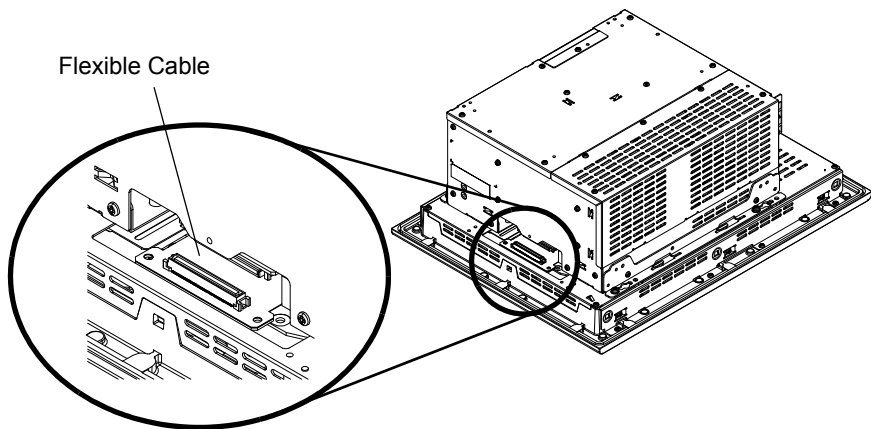

- (3) Remove the four screws on the installation fasteners for the control box.

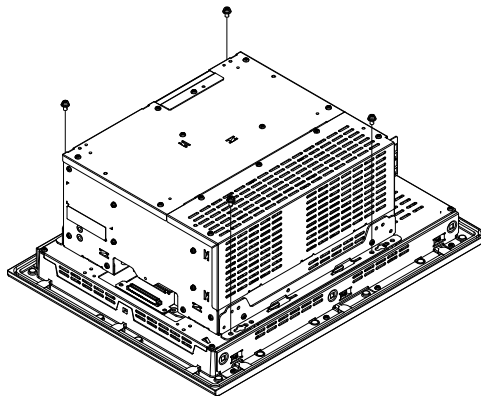

- (4) Slide the control box in direction shown by the arrow.

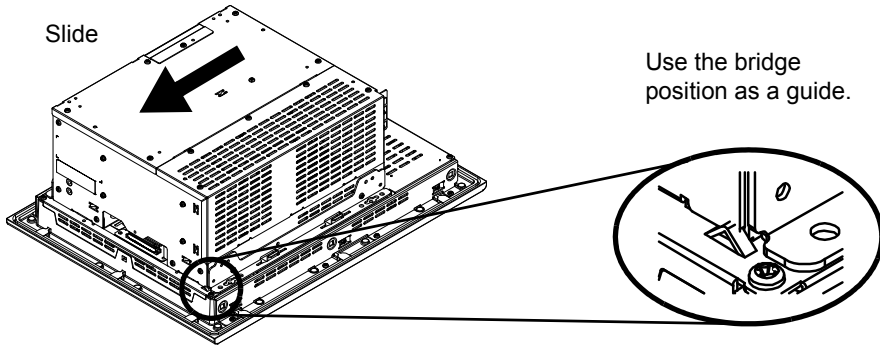

- (5) Lift the control box and remove the front module tabs from the slot on the installation fasteners for the control box. Then remove the control box.

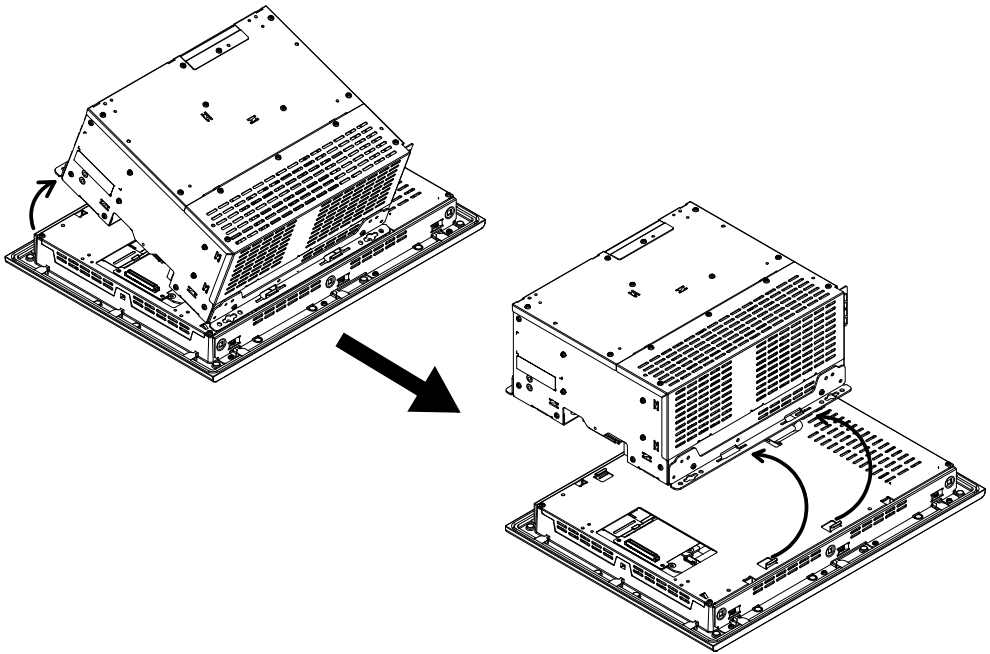

■ Installing the control box on the front module

Install the control box on the front module in the reverse order of the removal steps of (1) to (5).

The necessary torque is 0.5N•m to 0.6N•m in every step.

5.3 Peripheral Device Installation

A wide variety of devices manufactured by Pro-face such as optional units, DIM modules and CF Cards as well as commercial expansion boards can be used with the PL unit.

When installing the optional units, refer to each unit's "Installation Guide".

⚠ WARNING

- ⊘ Be sure to confirm that power is not being supplied to the PL unit before installing or removing any optional units, DIM modules, CF Cards, expansion boards or other devices. Failure to do so can result in an electric shock.

IMPORTANT

- In the Soft OFF status, power is supplied to some of the circuits even when the monitor screen connected to the front module or the PL unit is blank. Before installing and removing the peripheral equipment, be sure to confirm that its power supply switch is OFF or its power cable is not connected.
- Use a screwdriver to loosen or tighten the screws. Be sure not to tighten screws too tightly, since it may damage the unit.
- When removing or replacing screws, be careful that they do not fall inside the PL unit's chassis.

5.3.1 Removal/Attachment of the Switch Cover

With the PL-3000B series unit, remove the switch cover to operate the internal switches or replace the batteries for clock data backup.

Unscrew the attachment screw securing the switch cover, and remove the cover.

For the PL-3000B series unit, install the switch cover back on the control box after completing the switch operation or the battery replacement. The torque should be 0.5 to 0.6 N•m.

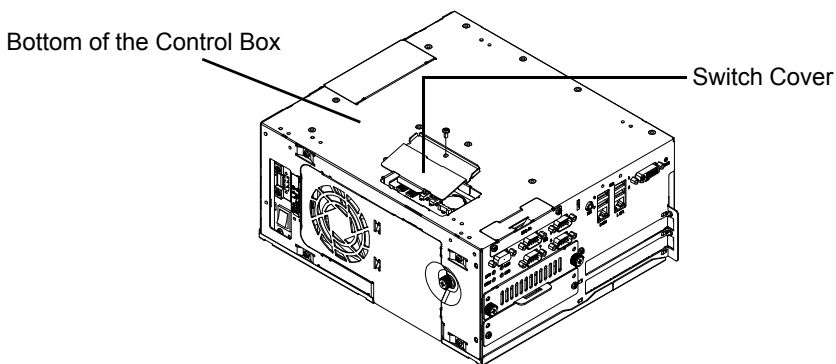

5.3.2 Attachment of the Power Switch Cover

When using the AC type, the included power switch cover needs to be installed to meet ANSI/ISA standards. Attach power switch cover with the accompanying two screws to the PL unit. The torque should be 0.5 to 0.6 N•m.

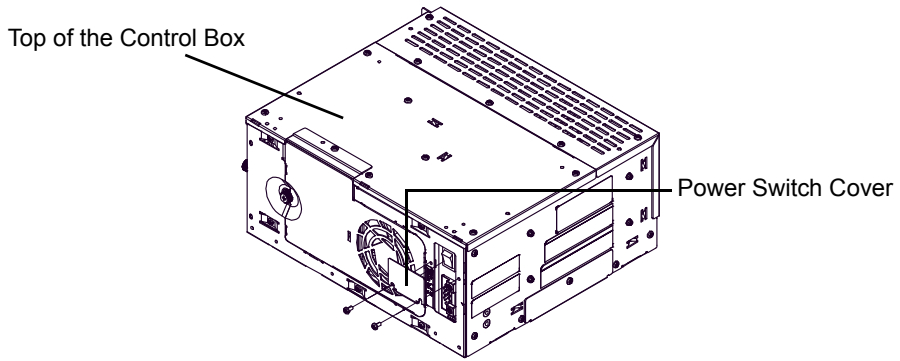

5.3.3 Removal of Expansion Slot Cover

When installing the main memory or the expansion board, remove the expansion slot cover.

- (1) Remove the screws (5) from the expansion slot cover.

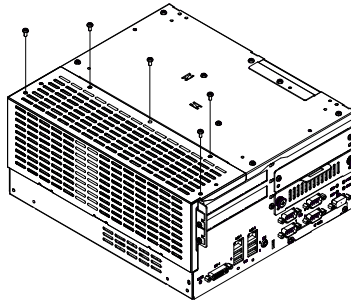

- (2) While pulling up slightly, open the cover toward you to remove it.

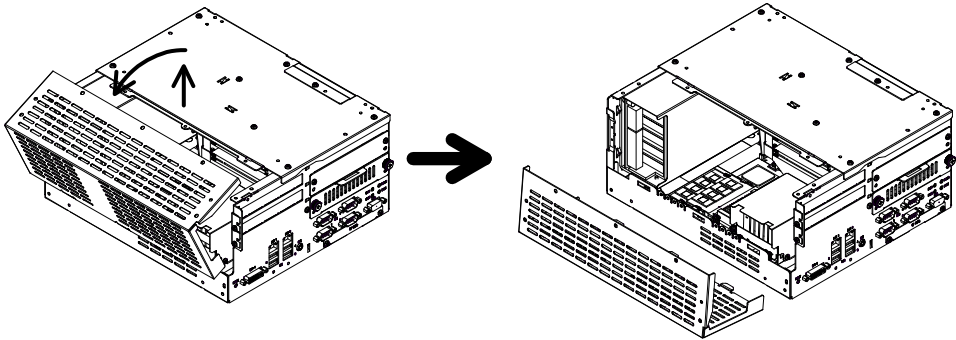

- (3) After completing the installation, hang the clips of the expansion slot cover on the elongated holes (3) of the PL unit, and secure the cover in place by lifting it up slightly. The torque should be 0.5 to 0.6 N•m.

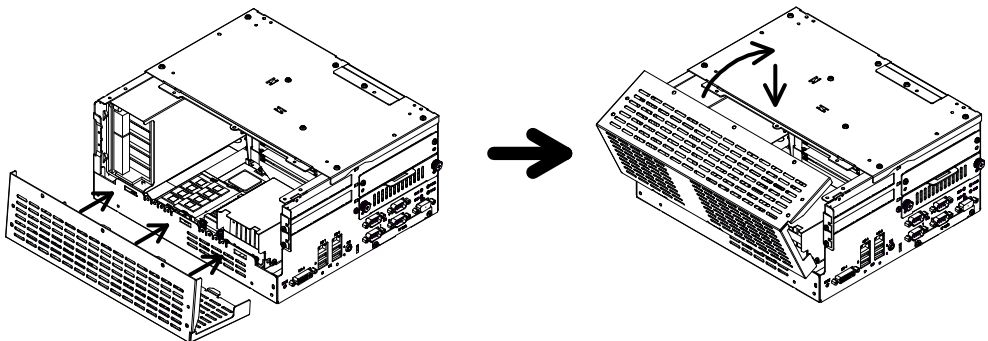

5.3.4 Main Memory Installation

- (1) Remove the PL unit's expansion slot cover.

SEE → 5.3.3 Removal of Expansion Slot Cover (page 5-15)

- (2) The DIM modules are installed in the DIM sockets as shown in the figure below. Angle the module down slightly, insert it completely into the connector, and then push it in until the stopper snaps into place.

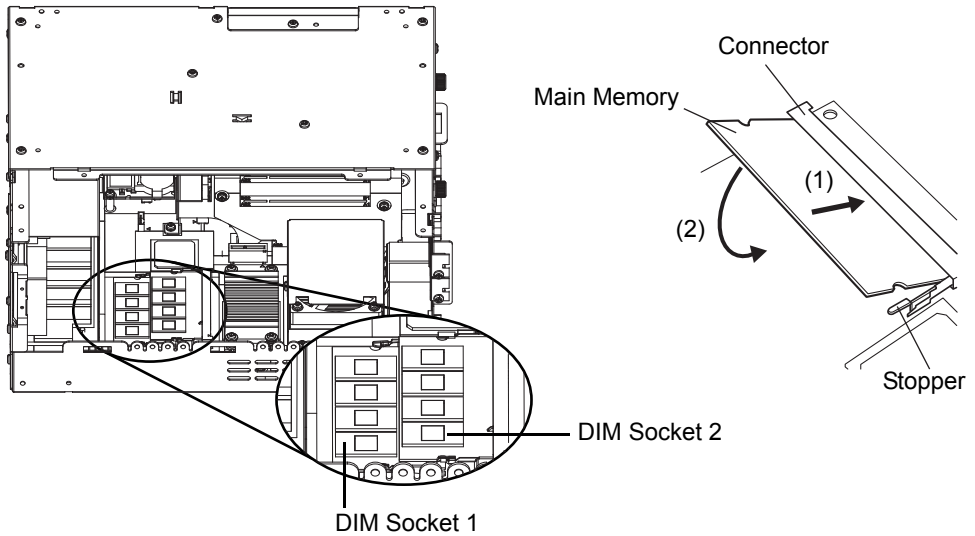

5.3.5 Expansion Board Installation

- (1) Remove the PL unit's expansion slot cover.

SEE → 5.3.3 Removal of Expansion Slot Cover (page 5-15)

- (2) Remove the screw from the blank panel of the expansion slot and detach the blank panel.

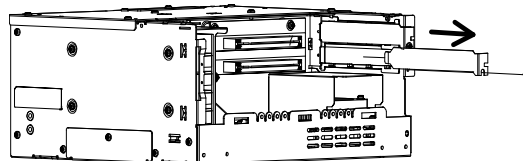

- (3) Insert the expansion board (commercial type) into the expansion board connector, and secure it in place using the blank panel's screw. The torque should be 0.5 to 0.6 N•m.

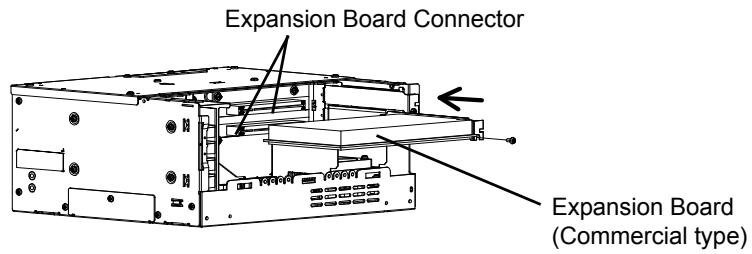
**NOTE**

- For information on expansion board slot sizes, see “ ■ *Expansion Slots (page 3-8)*”.

5.3.6 HDD/SSD Unit Installation

⚠ CAUTION

❗ Be sure to turn off the PL unit before installing the HDD unit. Neglecting to do so may result in a failure.

IMPORTANT

- Since the HDD unit is a precision instrument that has a low resistance to shocks, be sure it is neither hit by nor pressed strongly against another object when installing it.
- Even when the screen display of the monitor connected to the PL unit is blank, the power might be distributed internally (for example, in the Standby state). Make sure that the power supply of the PL unit is off when installing or removing the HDD/SSD unit.
- When using the software mirroring utility (APL-SM3000), you can replace a faulty HDD drive with the PL unit operating. The software mirroring utility is not corresponding to the SSD unit. For details, refer to “Software Mirroring Utility APL-SM3000 Reference Manual.”

(1) Unscrew the attachment screws (2) from the HDD slot to remove the slot cover.

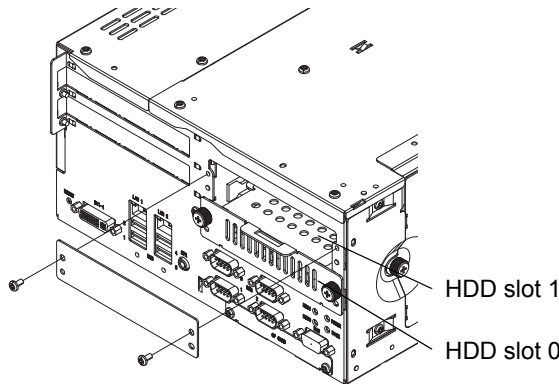

(2) Hold the HDD/SSD unit's handle and insert the unit slowly (to avoid a sudden movement) into the PL unit along the guide rail until the connector is completely connected.

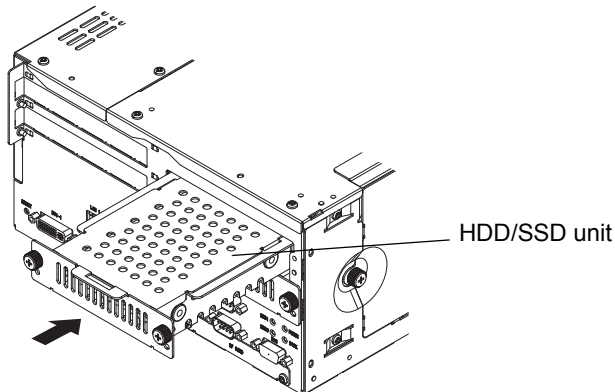

(3) Secure the HDD/SSD unit in place using the HDD slot screws (2). The torque should be 0.2 to 0.3 N•m.

5.3.7 CF Card Insertion/Removal

⚠ CAUTION

- ⊘ Prior to inserting or removing a CF Card, be sure to confirm that the PL unit is turned OFF. If you do not, CF Card internal data may be damaged or lost or the OS may stop.
- ⊘ While a CF Card is being accessed (Disk Access Lamp: Lit in green), NEVER turn OFF or reset the PL, or insert or remove the CF Card. If you do not, CF Card internal data may be damaged or lost.
- ⚠ Prior to inserting a CF Card, familiarize yourself with the CF Card's front and rear face orientation, as well as the CF Card connector's position. If the CF Card is not correctly positioned when it is inserted into the Multi Unit, the CF Card's internal data, CF Card and the PL unit may be damaged or broken.
- ⚠ Be sure to use only CF Cards manufactured by Pro-face. The CF Card's internal data may be damaged when using another manufacturer's CF Card.
- ⚠ Once PL data is lost, it cannot be recovered. Since accidental data loss can occur at any time, be sure to back up all PL screen and CF Card data regularly.
- ⊘ Be sure to follow the instructions given below to prevent the CF Card's internal data from being destroyed or a CF Card malfunction from occurring:
 - DO NOT bend the CF Card.
 - DO NOT drop or strike the CF Card against another object.
 - Keep the CF Card dry.
 - DO NOT touch the CF Card connectors.
 - DO NOT disassemble or modify the CF Card.

■ Inserting the CF Card

- (1) Unscrew the attachment screws (2) from the CF Card cover and then remove the CF Card cover.

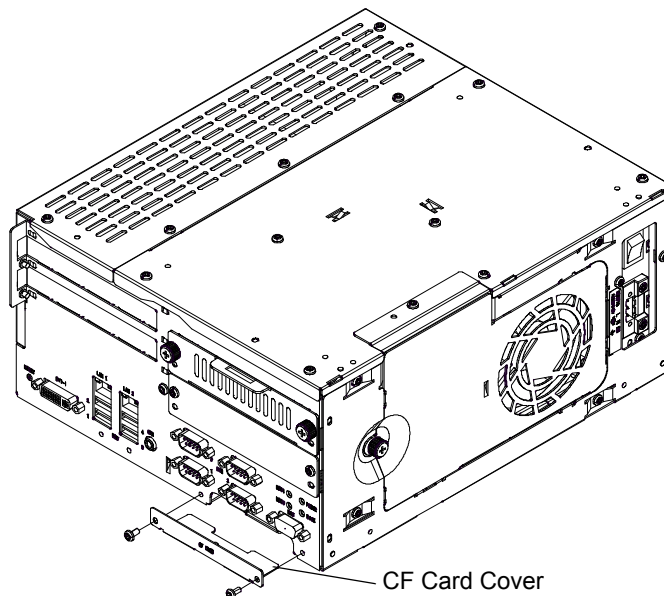

- (2) Insert the CF Card firmly into the CF Card slot, and check that the eject button pops out.

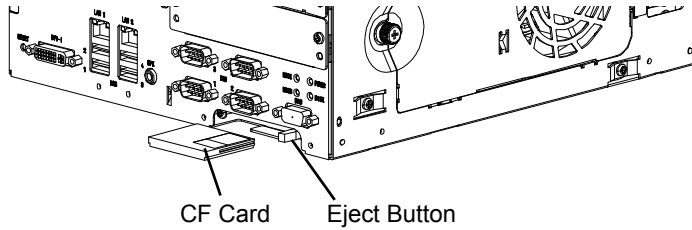

- (3) Install the CF Card cover and fix it with two screws. The torque should be 0.5 to 0.6 N•m.

■ Removing the CF Card

- (1) Press the eject button in fully to remove the CF Card from the CF Card slot.
- (2) Replace the CF Card cover and secure it in place using the attachment screws (2). The torque should be 0.5 to 0.6 N•m.

■ Backup of CF Card

The CF Card has a data overwrite limit of approximately 100,000 times. Therefore, be sure to back up all CF Card data regularly to another storage media. (100,000 times assumes the overwriting of 500 KB of data in DOS format.)

If your PC is equipped with a PC Card Slot:

- (1) Install the CF Card into a CF Card Adapter (GP077-CFAD10) and insert it into a PC card slot of a personal computer.
- (2) Save the data of the CF Card with your personal computer.

If your PC is NOT equipped with a PC Card slot:

- (1) Use a commercially available PC Card Reader, or a CF Card Reader.

5.3.8 Connecting USB Cable Clamp

This clamp is used to prevent the USB cable connected to the USB Interface of the PL unit from being unplugged due to vibration or other causes.

■ Attaching the USB Cable Clamp

- (1) Place the PL unit face-down on a flat surface as shown below. Your PL unit has four USB connectors.

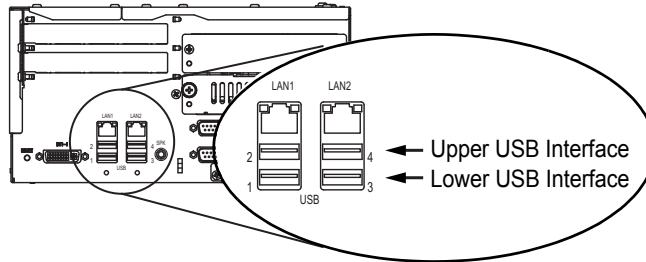

NOTE

- When using two or more USB ports, be sure to first connect one USB cable to the lower USB connector, and then connect the second USB cable to the upper USB connector.
- When using only one of the USB ports, be sure to use the lower USB connector. This allows you to securely clamp the USB cable in the cable clamp.

- (2) Fix the USB holder with two screws. The torque should be 0.5 to 0.6 N•m.

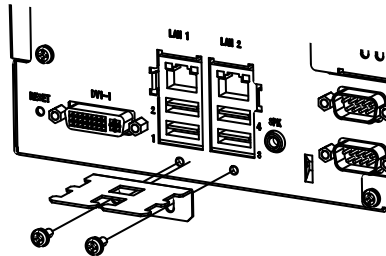

- (3) As the figure shows, pass the USB Cable Clamp's band around the depressed surface of the holder, twist the USB Cable Clamp's band around the USB cable, pull the band in the direction of the arrow, and then fasten the band using the clamp.

NOTE

- Be sure the clamp is securely holding the USB cable's plug and collar.
- Be sure the clamp is positioned as shown below, with the clamp pointing upwards - not to the side. This is to keep the clamp from interfering with nearby connectors and their cables.

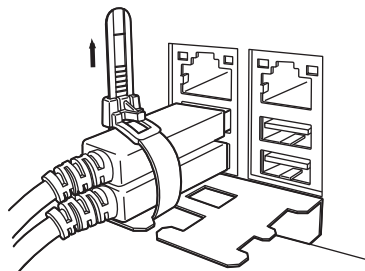

■ Removing the USB Cable Clamp

To remove the clamp from the USB cables, push down on the clamp strap's clip to release it while pulling up on the clamp.

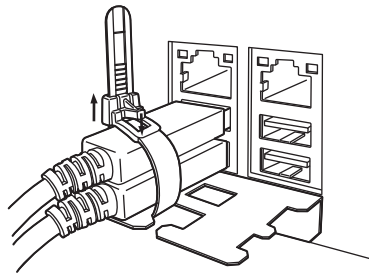

5.4 Wiring Precautions

This section describes the procedures and precautions for wiring power cords.

5.4.1 Connecting the Power Cord

⚠ WARNING

- ❗ To avoid an electric shock, prior to connecting the PL unit's power cord terminals to the power terminal block, confirm that the PL unit's power supply is completely turned OFF, via a breaker, or similar unit.
- ❗ Supplying a power voltage other than that specified will damage the power source and the PL unit.
- ❗ Since there is no power switch on the DC type unit, be sure to attach a breaker-type switch to the power cord.
- ❗ When the FG terminal is connected, be sure the wire is grounded.

IMPORTANT

- When the FG terminal is connected, be sure the wire is grounded. Not grounding the PL unit will result in excess noise and vibration.
- The SG and FG terminals are connected internally in the PL unit.
When connecting the SG wire to another device, be sure that the design of the system/connection does not produce a shorting loop.

■ Power Connector

The following parts are used in the power connector (plug).

	Supplied Power Connector	Shape
AC type	CA7-ACCNL-01 by Pro-face	Straight Spring
	FKC 2,5/3-STF-5,08 by Phoenix Contact *1	
DC type	CA7-DCCNL-01 by Pro-face	
	GFKC 2,5/3-STF-7,62 by Phoenix Contact *1	

When PL-3000B Series is mounted vertically, a right-angle power connector is recommended. Use the following right-angle power connectors.

	Optional Power Connector	Shape
AC type	CA7-ACCNLR-01 by Pro-face	Right-angle Spring
	FKCVR 2,5/3-STF-5,08 by Phoenix Contact *1	
DC type	CA5-DCCNL-01 by Pro-face	Right-angle Screw
	GMVSTBW 2,5/3-STF-7,62 by Phoenix Contact *1	

*1 For details, please contact your local Phoenix Contact distributor.

■ Spring-type Power Connector

Use the following procedure to connect a spring-type power connector to all compatible power supply units, whether AC or DC type:

SEE → ■ Power Connector (page 5-23)

Power Cord Specifications

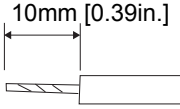
Power Cord Diameter	0.75 to 2.5mm ² (18 to 12 AWG)
Conductor Type	Solid or stranded Wire *1
Conductor Length	 <p>10mm [0.39in.]</p>

*1 If the conductor's end (individual) wires are not twisted correctly, they may short against each other or an electrode.

IMPORTANT

- Use copper conductors only.
- Temperature rating of field installed conductors: 75°C only.

Wiring

When connecting the power cord, use the following items. (Made by Phoenix Contact.*1)

Recommended Driver	SZS 0.6x3.5 (1205053)
Recommended Pin Terminals	AI 0.75-10GY (3201288) AI 1-10RD (3200182) AI 1.5-10BK (3200195) AI 2.5-12BU (3200962)
Recommended Pin Terminal Crimp Tool	CRIMPFOX ZA3 (1201882)

*1 For details, please contact your local Phoenix Contact distributor.

Connecting the Power Cord

- (1) Confirm that power is not supplied to the PL unit.
- (2) Push the Opening button with a small slot screw driver to open the desired pin hole.
- (3) Insert each pin terminal into its designated hole. Release the opening button to clamp the pin place.

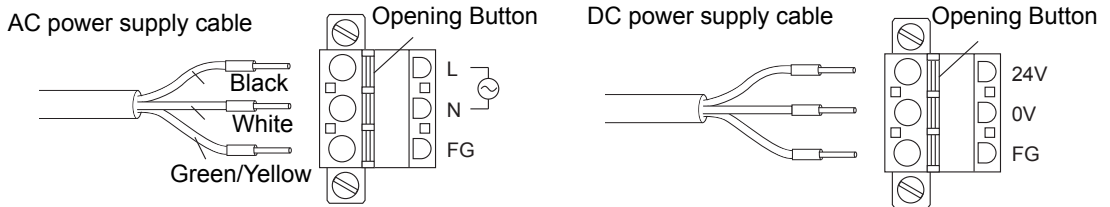

- (4) After inserting all three pins, insert the power plug into the power connector at PL. Fix the plug with two (2) slot screws.

IMPORTANT

- Confirm that all wires are connected correctly.
- The torque required to tighten these screws is 0.5 to 0.6 N•m.
- To prevent the possibility of a terminal short, use a pin terminal that has an insulating sleeve.

■ Screw-type Power Connector

When the DC type PL3000B series unit is installed vertically, use the screw-type DC power supply connectors (right-angled). Use the following procedure to connect a screw-type power connector to DC power supply units :



■ Power Connector (page 5-23)

Power Cord Specifications

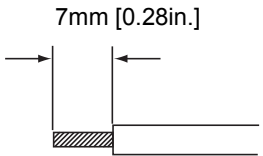
Power Cord Diameter	0.75 to 2.5mm ² (18-12 AWG)
Conductor Type	Solid or stranded Wire* ¹
Conductor Length	7mm [0.28in.] 

*¹ If the conductor's end (individual) wires are not twisted correctly, they may short against each other or an electrode.

IMPORTANT

- Use copper conductors only.
- Temperature rating of field installed conductors: 75°C only.

Wiring

When connecting the power cord, use the following items. (Made by Phoenix Contact*1.)

Recommended Driver	SZF 1-0.6x3.5 (1204517)
Recommended Pin Terminals	AI 0.75-8GY (3200519) AI 1-8RD (3200030) AI 1.5-8BK (3200043) AI 2.5-8BU (3200522)
Recommended Pin Terminal Crimp Tool	CRIMPFOX ZA3 (1201882)

Power Connector (Right-angle Screw) Specifications

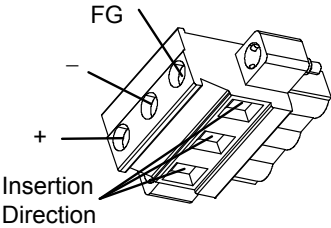
	+	24V
	-	0V
	FG	FG Grounding Terminal connected to the PL

Connecting the Power Cord

- (1) Confirm that the power is not supplied to the PL unit.
- (2) Loosen three screws in the center of the power connector.
- (3) Strip the membrane of the power cord, twist the wire ends, and connect them to the power connector.

IMPORTANT

- Use a flat-blade screwdriver (Size 0.6 X 3.5) to tighten the terminal screws. The torque required to tighten these screws is 0.5 to 0.6 N•m [5-7 lb•in.].
- Do not solder the cable connection. Doing so may damage the unit due to abnormal heat or cause a fire.

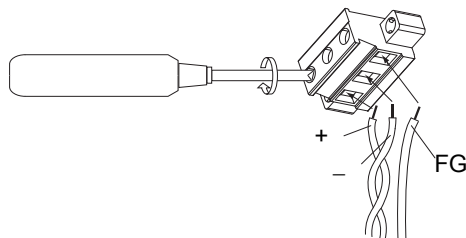

- (4) Attach the Power Connector to the PL and fix it to the PL main unit with right/left tightening screws.

*1 For details, please contact your local Phoenix Contact distributor.

5.4.2 Connecting the Power Supply

This section describes the precautions for supplying a power voltage.

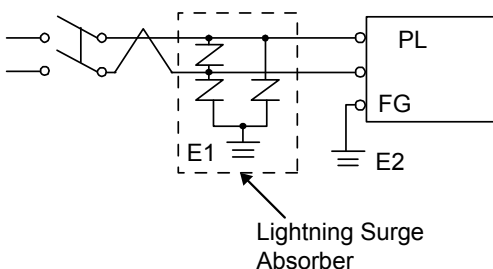
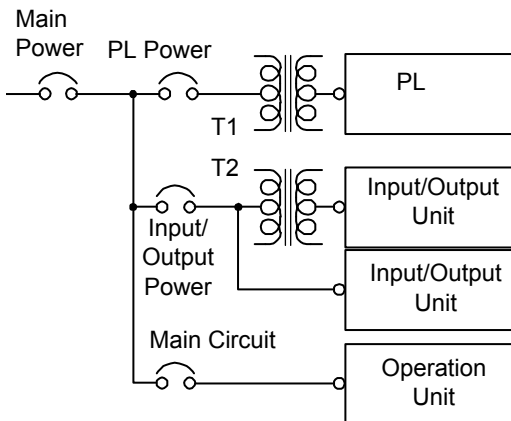
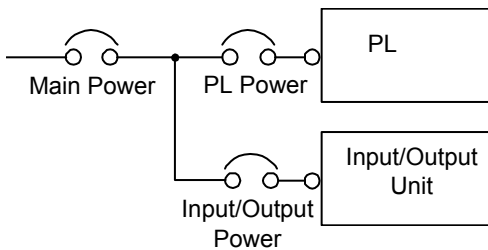
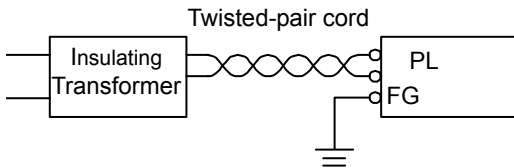
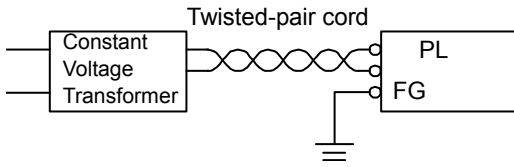

- If the supplied voltage exceeds the PL unit's range, connect a constant voltage transformer.

SEE → Chapter 3 "Specifications" (page 3-1)

- Between the line and ground, select a power supply that is low in noise. If there is an excess amount of noise, connect an insulating transformer.

IMPORTANT

- Use constant voltage and insulating transformers with capacities exceeding Power Consumption value.

- When supplying power to the PL unit, be sure to separate the input/output and power lines, as shown.
- To increase the noise resistance quality of the power cord, simply twist each power wire before attaching the Ring Terminal.
- The power supply cable must not be bundled or positioned close to main circuit lines (high voltage, high current), or input/output signal lines.
- Connect a lightning surge absorber, as shown in the diagram, to deal with power surges.
- To avoid excess noise, make the power cord as short as possible.
- Branch Circuit Protective device shall be use for rating 20A for DC24V input device.

IMPORTANT

- Be sure to ground the surge absorber (E1) separately from the PL unit (E2).
- Select a surge absorber that has a maximum circuit voltage greater than that of the peak voltage of the power supply.

5.4.3 Grounding

This section describes the precautions for grounding the PL unit.

⚠ CAUTION

❗ Do not use common grounding, since it can lead to an accident or machine breakdown.

(a) Exclusive Grounding (BEST)

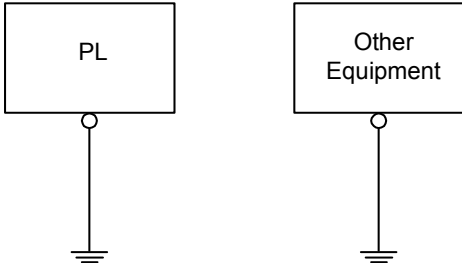

• When supplying power to the PL unit, be sure to separate the input/output and power lines, as shown. [diagram (a)]

IMPORTANT

- Check that the grounding resistance is 100Ω or less.
- FG and SG terminals are internally connected in the PL. When connecting an external device to the PL using the SG terminal, be sure to check that no short-circuit loop is created when you setup the system.

(b) Exclusive Grounding (OK)

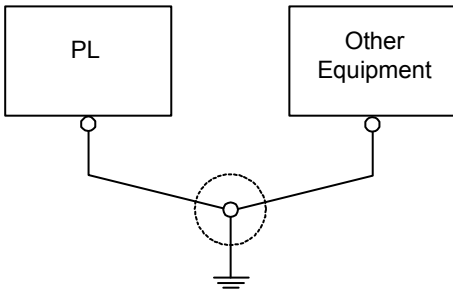

- The grounding wire should have a cross sectional area greater than 2mm². Create the grounding point as close to the PL unit as possible, and make the wire as short as possible. When using a long grounding wire, replace the thin wire with a thicker wire, and place it in a duct.

(c) Common Grounding (Not OK)

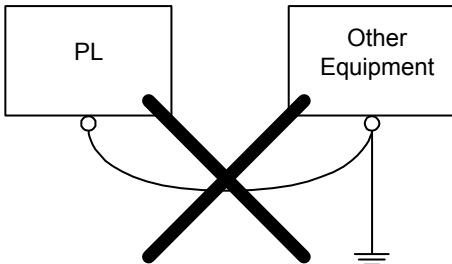

• If exclusive grounding is not possible, use a common grounding point. [diagram (b)] A grounding or equivalent should be used for the grounding point.

NOTE

- If the equipment does not function properly when grounded, disconnect the ground wire from the FG terminal.

5.4.4 I/O Signal Line Placement

- Input and output signal lines must be separated from the power control cables for operating circuits.
- If this is not possible, use a shielded cable and ground the edge of the shield.

6

Maintenance

1. Cleaning the Fan Filter
2. Periodic Check Points
3. Replacing the Installation Gasket
4. Replacing the Backlight
5. Replacing the Internal Battery

This chapter explains cautions and inspection criteria that will ensure trouble-free use of the PL.

6.1 Cleaning the Fan Filter

Since excessive dirt and dust in the filter of the PL's electric fan can potentially affect the performance of the unit, regular inspection and cleaning of the filter is strongly recommended.

IMPORTANT

- The PL's fan has a lifetime. (Expected life: approx. 5 years at the ambient temperature 25°C)
This lifetime may be shortened depending on the usage environment.
When the fan needs to be replaced, please contact your local PL distributor immediately.

NOTE

- The fan rotation speed can be monitored on the System Monitor.

SEE → *PL3000 Series Reference Manual*

- (1) Unscrew the attachment screw (1) from the fan cover and then remove the fan cover.

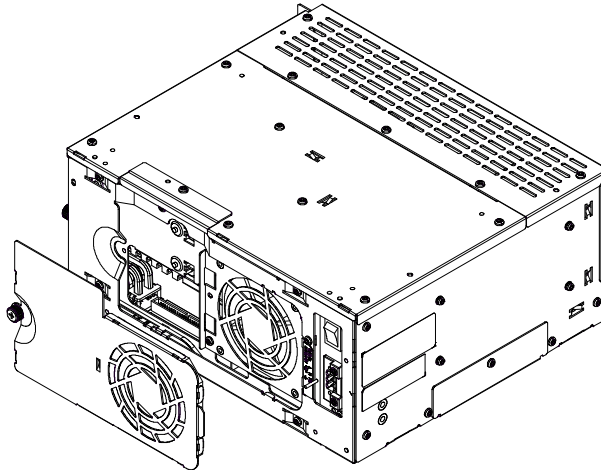

- (2) Remove the filter from the fan cover.

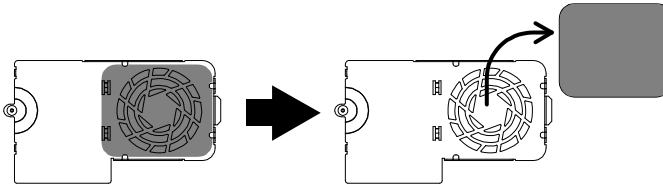

(3) Clean the filter completely. If stubborn dirt or stains are present, wash the filter with a neutral detergent.

IMPORTANT

- Do not wring the filter to dry it.

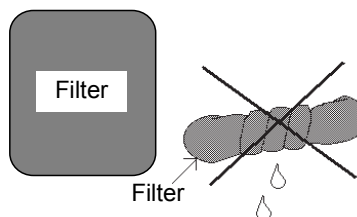

- When drying the filter, dry it without exposing it to direct sunlight.
- Allow it to air dry completely before reattaching to the PL.

(4) After reattaching the filter to the filter cover by hanging the filter on the fan cover's clips, reattach the fan cover using the cover's attachment screws. The torque should be 0.2 to 0.3 N•m.

IMPORTANT

- Be sure the fan cover is securely attached to the PL unit. This is to ensure the fan cover does not fall off while the PL unit is operating.

6.2 Periodic Check Points

To keep your PL unit in its best condition, please inspect the following points periodically.

■ PL Operation Environment

- Is the surrounding air temperature within the allowable range?

0°C to 50°C (without HDD) 5°C to 50°C (with HDD)

- Is the ambient humidity within the specified range?

10 to 90%RH (Not condensing, wet bulb temperature: 39°C or less.

Wet bulb temperature with HDD: 29°C or less.)

- Is the operating atmosphere free of corrosive gasses?

When using the PL unit inside a panel, the ambient environment refers to the interior of the panel.

■ Electrical Specifications

- Is the input voltage appropriate?

AC type: AC85 to 265V, 50/60Hz

DC type: DC19.2 to 28.8V

■ Related Items

- Are all power cords and cables connected properly? Have any become loose?
- Are all mounting brackets holding the unit securely?
- Are there many scratches or traces of dirt on the installation gasket?

6.3 Replacing the Installation Gasket

The installation gasket provides protection against dust and moisture.

IMPORTANT

- A gasket which has been used for a long period of time may have scratches or dirt on it, and could have lost much of its water resistance. Be sure to change the gasket at least once a year, or when scratches or dirt become visible.
- The model number of the PL unit installation gaskets is described below.

PL-3600T Series	CA7-WPG12-01
PL-3600K Series PL-3700T Series	CA7-WPG15-01
PL-3700K Series	CA7-WPG15K-01
PL-3900T Series	CA7-WPG19-01

■ Installation Gasket Attachment Procedure

- (1) Place the PL on a flat, level surface facing the display face downwards.
- (2) Remove the gasket from the PL.
- (3) Attach the new gasket to the PL. Be sure to insert the gasket into the PL groove so that the gasket's groove faces downwards.

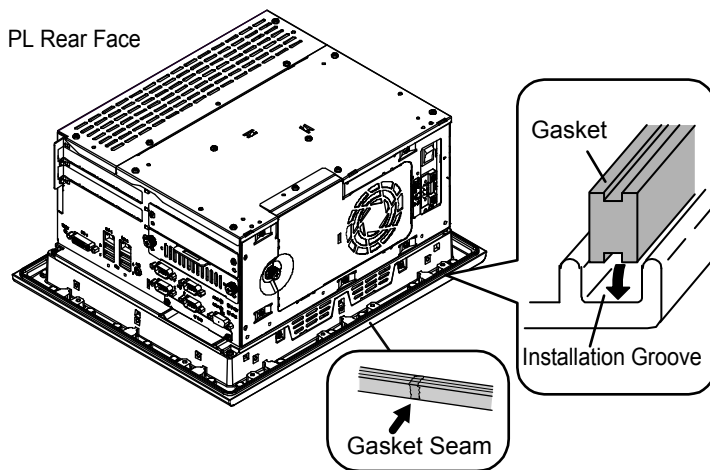

- (4) Check that the gasket is attached correctly to the PL.

IMPORTANT

- The gasket must be inserted correctly into the groove for the PL's moisture resistance to be equivalent to IP65f.
- Since the gasket is flexible but not elastic, be careful not to stretch it unnecessarily, as doing so could tear the gasket.
- Be sure the gasket's seam is not inserted into any of the unit's corners, only in the straight sections of the groove. Inserting it into a corner may lead to its eventually tearing.
- To ensure stable resistance against dust and moisture, insert the gasket so that the seam is at the bottom of the PL unit.
- The upper surface of the gasket should protrude approximately 2.0mm [0.08in] out from the groove. Be sure to check that the gasket is correctly inserted before installing the PL into a panel.

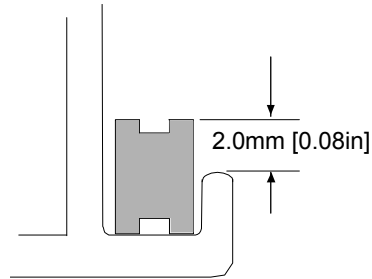

6.4 Replacing the Backlight

6.4.1 PL-3600* Series

IMPORTANT

- The backlights of the following PL cannot be replaced by the user. When the backlight needs to be replaced, please contact your local distributor.
 - PL units which need to be compliant with ANSI/ISA standards.
 - PL units whose Revision "5" is marked on the label of the front module.

PL units use a long-life type backlight. The actual life of the backlight however, will vary depending on the PL's operating conditions. It is recommended that it be replaced periodically. The service life (half brightness life) of the backlight when it is lit continuously at room temperature is as described below.

50,000 hours --- approx. 5.7 years (ambient temperature: 25°C, when lit continuously)

NOTE

- When the LED setting is specified with the RAS control in Control Panel and a backlight burnout is detected, the status LED blinks in orange/red.
- If the backlight or the display unit is damaged, the screen display will go out. Even if the screen goes out, however, there is a possibility that the touch panel is still operating correctly. Therefore, since any type of touch panel contact could have an unexpected or dangerous effect or result, be sure not to touch the screen when this condition occurs.
- A backlight burnout is detected by monitoring the consumed current. Depending on the condition of the backlight, a backlight burnout may not be detected or it may be detected before the backlight burns out completely.

⚠ WARNING

⚠ [Electric shock]

- Whenever changing the backlight, be sure the PL's power cord has been disconnected and that the unit is cooled down.
- When the PL's power cord is connected and the PL is ON, high voltage runs through the wires in the backlight area, do not touch them!

⚠ [Burn]

- When the PL's power has just been turned OFF, the backlight area is still very hot! Be sure to wear gloves to prevent being burned.

⚠ [Glass]

- The backlight is very fragile. Do not touch the glass tube directly or try to remove its power cord, if the glass tube breaks you may be injured.

■ Preparation

Please have the following ready beforehand.

- Replacement backlight (Model:CA3-BLU12-01)
- One pair of clean (preferably new) cotton gloves.
- Phillips screwdriver (no.2)

■ Replacement procedure

Be sure to wear gloves when exchanging the backlight, and follow the following procedures.

- (1) Turn OFF the power switch of the PL and remove the power cable.
- (2) Remove the PL unit from the equipment (panel etc.) to which the unit has been incorporated, and place the PL unit on a flat, level surface facing the display face downwards.

IMPORTANT

- Be sure to perform the backlight changeover on a flat, level surface. This will prevent damage to the PL unit and the accidental cutting of any of its power cord.
- Be sure to protect the display surface to prevent damage during the operations.

- (3) Remove the control box from the front module.



5.2 Installing/removing the front module and the control box (page 5-9)

- (4) Unscrew the four (4) attachment screws securing the rear cover on the front module, and remove the cover of the module.

IMPORTANT

- If the rear cover feels warm to the touch, you may get burned by the cover. Replace the backlight after the PL unit is cooled down enough.

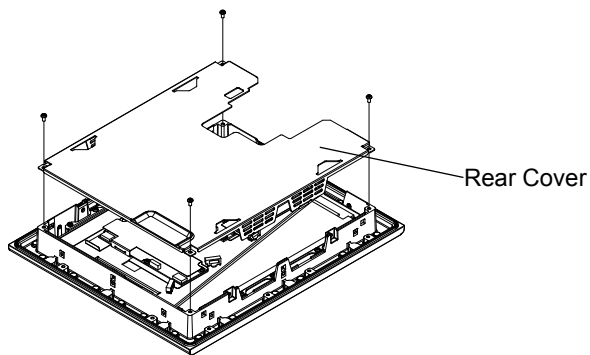

- (5) Loosen the backlight attachment screw.

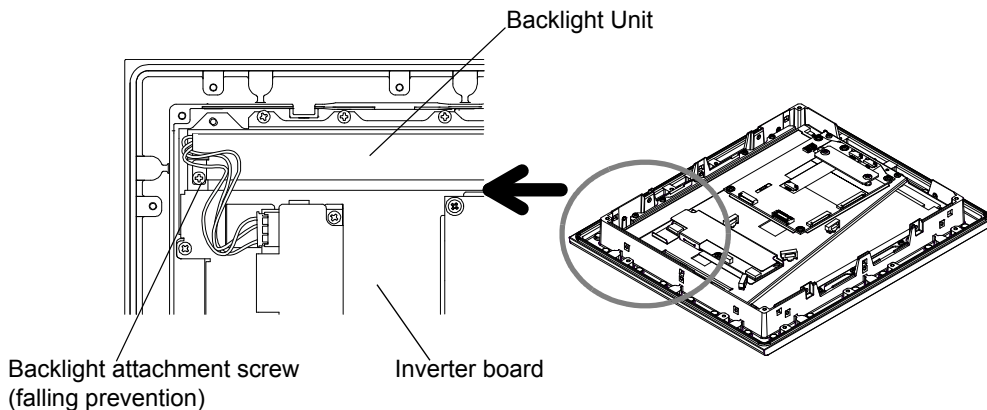

- (6) Remove the tape on the backlight connector and disconnect the cable of the backlight unit from the backlight connector on the inverter board.

For the PL-3600K series, then disconnect the cable from the cable clamp.

IMPORTANT

- Compliance with ANSI/ISA standards is not met if the tape on the backlight connector is removed. When the backlight needs to be replaced, please contact your local PL distributor.

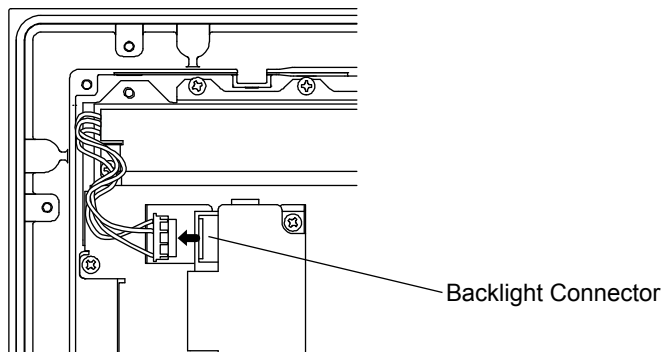

- (7) Lift the backlight unit up and then pull it out slowly as shown below.

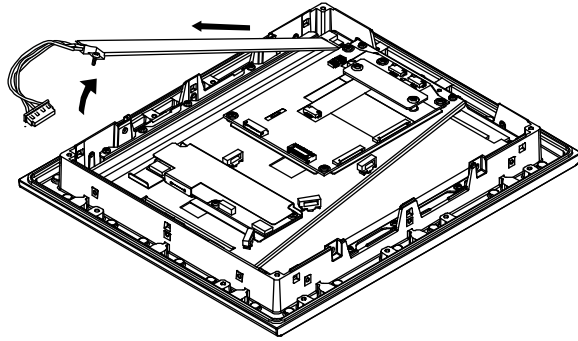

- (8) Insert the tip of a new backlight, and install this backlight into the groove.

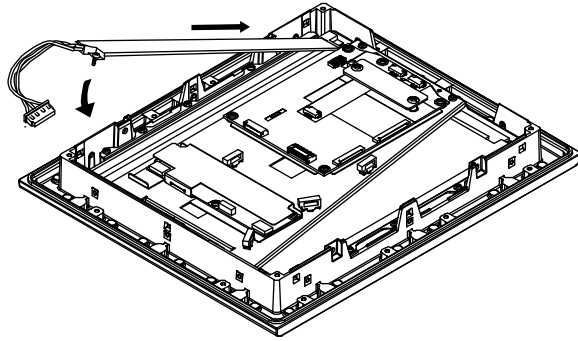

- (9) Connect the backlight cable to the backlight connector.

For the PL-3600K series, then secure the cable with the cable clamp.

IMPORTANT

- Be sure to insert the cable into the connector securely. Failure to do so may damage the connector.

- (10) Secure the backlight unit in place with the backlight attachment screw. The torque should be 0.147 N•m.

- (11) Confirm that the backlight unit is secured in place, and install the rear cover on the front module with the four (4) attachment screws. The torque should be 0.5 N•m.

IMPORTANT

- Pay attention not to catch the cable in the gap between the rear cover and the front module.
- If any of the screws is missing, check if it fell inside the PL unit's chassis. If the power is turned ON while a screw is inside, it may cause an accident or fire.

- (12) Perform steps (1) to (3) in reverse order.

6.4.2 PL-3700* Series

IMPORTANT

- The backlights of the following PL cannot be replaced by the user. When the backlight needs to be replaced, please contact your local distributor.
 - PL units which need to be compliant with ANSI/ISA standards.
 - PL units whose Revision "5" is marked on the label of the front module.

PL units use a long-life type backlight. The actual life of the backlight however, will vary depending on the PL's operating conditions. It is recommended that it be replaced periodically. The service life (half brightness life) of the backlight when it is lit continuously at room temperature is as described below.

50,000 hours --- approx. 5.7 years (ambient temperature: 25°C, when lit continuously)

NOTE

- When the LED setting is specified with the RAS control in Control Panel and a backlight burnout is detected, the status LED blinks in orange/red.
- If the backlight or the display unit is damaged, the screen display will go out. Even if the screen goes out, however, there is a possibility that the touch panel is still operating correctly. Therefore, since any type of touch panel contact could have an unexpected or dangerous effect or result, be sure not to touch the screen when this condition occurs.
- A backlight burnout is detected by monitoring the consumed current. Depending on the condition of the backlight, a backlight burnout may not be detected or it may be detected before the backlight burns out completely.

⚠ WARNING

⚠ [Electric shock]

- Whenever changing the backlight, be sure the PL's power cord has been disconnected and that the unit is cooled down.
- When the PL's power cord is connected and the PL is ON, high voltage runs through the wires in the backlight area, do not touch them!

⚠ [Burn]

- When the PL's power has just been turned OFF, the backlight area is still very hot! Be sure to wear gloves to prevent being burned.

⚠ [Glass]

- The backlight is very fragile. Do not touch the glass tube directly or try to remove its power cord, if the glass tube breaks you may be injured.

■ Preparation

Please have the following ready beforehand.

- Replacement backlight (Model: CA7-BLU15-01 (Set of two lights))
- One pair of clean (preferably new) cotton gloves.
- Phillips screwdriver (no.2)

■ Replacement procedure

IMPORTANT

- The backlights are located at the top and bottom of the LCD. These two lights must be replaced together.

Be sure to wear gloves when exchanging the backlight, and follow the following procedures.

- (1) Turn OFF the power switch of the PL and remove the power cable.
- (2) Remove the PL unit from the equipment (panel etc.) to which the unit has been incorporated, and place the PL unit on a flat, level surface facing the display face downwards.

IMPORTANT

- Be sure to perform the backlight changeover on a flat, level surface. This will prevent damage to the PL unit and the accidental cutting of any of its power cord.
- Be sure to protect the display surface to prevent damage during the operations.

- (3) Remove the control box from the front module.

SEE → 5.2 Installing/removing the front module and the control box (page 5-9)

- (4) Unscrew the four (4) attachment screws securing the rear cover on the front module, and remove the cover of the module.

IMPORTANT

- If the rear cover feels warm to the touch, you may get burned by the cover. Replace the backlight after the PL unit is cooled down enough.

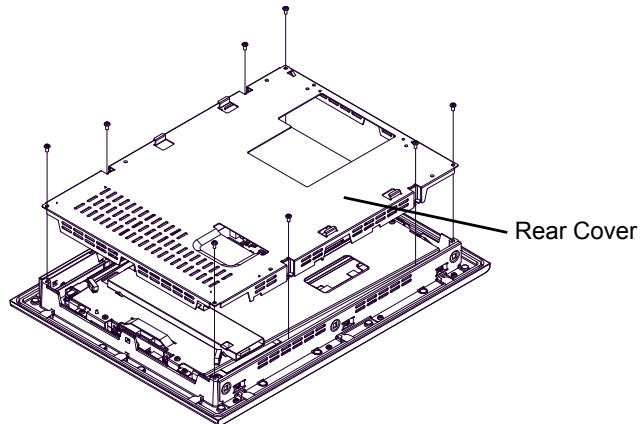

- (5) Loosen the four screws from the LCD holder.

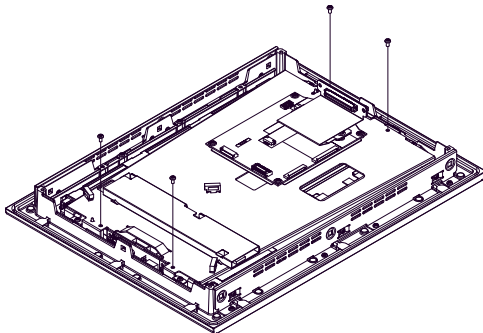

- (6) Loosen the upper and lower backlight attachment screws.

Backlight attachment screw

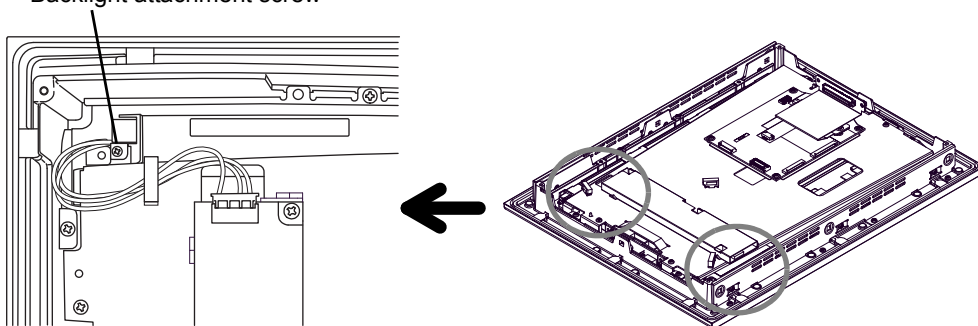

- (7) Remove the tape on the backlight connector, disconnect the cable of the backlight unit from the backlight connector on the inverter board, and remove it from the cable clamp.

IMPORTANT

- Compliance with ANSI/ISA standards is not met if the tape on the backlight connector is removed. When the backlight needs to be replaced, please contact your local PL distributor.

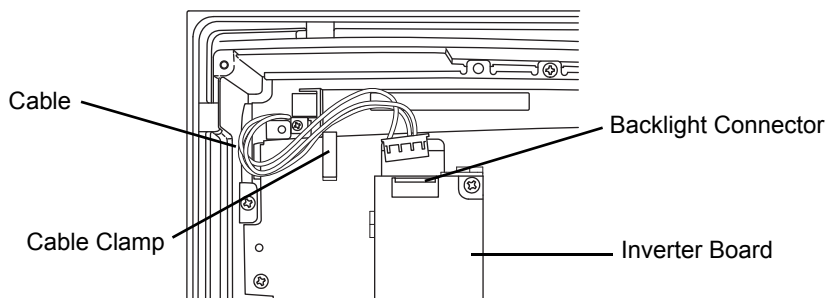

- (8) Lift the LCD holder up as shown in the figure and pull the cable in the direction of the arrow. The backlight unit can be drawn out from the port.

Backlight Unit

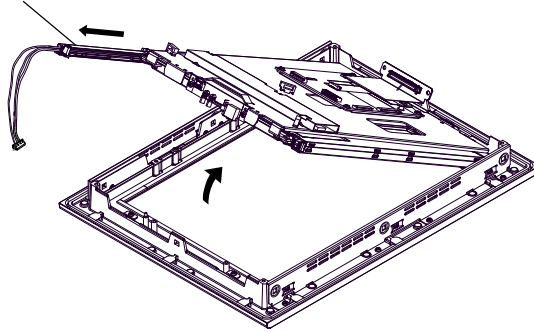

- (9) Insert a new backlight unit into the port.

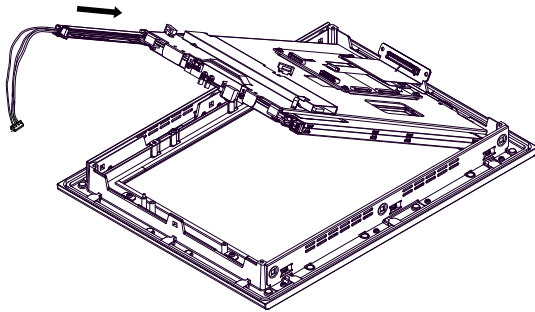

- (10) Lower the LCD holder, connect the backlight cables to the backlight connectors, and secure the cables with the clamp. (Repeat the steps (7) through (10) for the other backlight unit.)

IMPORTANT

- Be sure to insert the cable into the connector securely. Failure to do so may damage the connector.
- To prevent the cable from being caught when reassembling the PL unit, be sure to secure the backlight cables with the clamp before installing the rear cover.

- (11) Secure the backlight unit with the upper and lower backlight attachment screws. The torque should be 0.147 N•m.
- (12) Confirm that the backlight unit is secured in place, and then secure the LCD holder with the four screws. The torque should be 0.5 N•m.
- (13) Install the rear cover on the front module with the eight (8) attachment screws.

IMPORTANT

- Pay attention not to catch the cable in the gap between the rear cover and the front module.
- If any of the screws is missing, check if it fell inside the PL unit's chassis. If the power is turned ON while a screw is inside, it may cause an accident or fire.

- (14) Perform steps (1) to (3) in reverse order.

6.4.3 PL-3900T Series

PL units use a CFL, long-life type backlight. The actual life of the backlight however, will vary depending on the PL's operating conditions. It is recommended that it be replaced periodically.

The PL-3900T's backlight cannot be replaced by the user. When the backlight needs to be replaced, please contact your local PL distributor.

The service life (half brightness life) of the backlight when it is lit continuously at room temperature is as described below.

50,000 hours --- approx. 5.7 years (ambient temperature: 25°C, when lit continuously)

6.5 Replacing the Internal Battery

6.5.1 Replacing the Battery for Backup of Internal Clock Data

The PL unit has an internal battery for backup of internal clock data.

Compatible Battery	Service Life
Lithium Battery CR2032 (Hitachi Maxell, Ltd.)	5 years

IMPORTANT

- The expected battery service life is 5 years, however the battery may die before then. It is strongly recommended that you replace the battery regularly.
- When the battery is replaced, the BIOS settings are initialized. Configure the BIOS settings again after replacing the battery.

⚠ CAUTION

- ⚠ There is a danger of explosion if the PL unit's battery is incorrectly replaced. This battery should be replaced with equivalent type recommended by Pro-face.
- ⚠ Prior to replacing the battery, be sure to turn OFF the PL unit's power.
- ⚠ Be careful not to cause a short circuit.
- ⊘ Do NOT touch any internal parts except the battery and the battery holder.
- ⚠ During the replacement, be extremely careful not to drop the battery onto the PC board inside the PL unit. This may cause product failure.
- ⚠ Dispose of used batteries according to the battery manufacturer's instructions.

■ Battery Replacement Procedure

- (1) With the panel computer, remove the control box from the front module before replacing the battery.
With the PL-3000B series unit, remove the switch cover mounted on the bottom face of the PL unit.

SEE → 5.2 *Installing/removing the front module and the control box (page 5-9)*
5.3.1 *Removal/Attachment of the Switch Cover (page 5-13)*

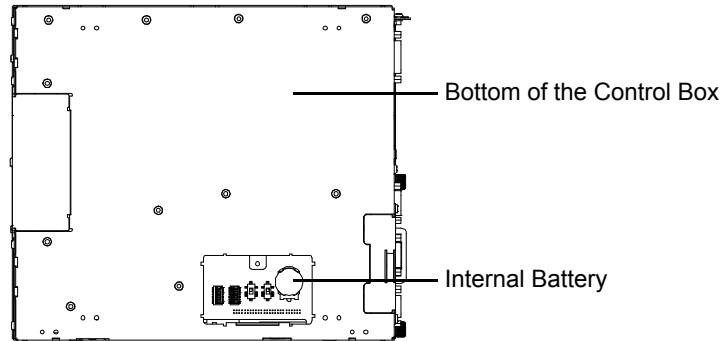

- (2) Remove the battery. Push the clip of the battery holder with your finger or small pliers and the battery is pushed up and removed.

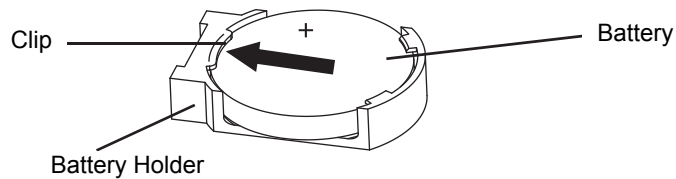

- (3) Insert the new battery. Insert the battery in the side of the clip of the battery holder first with the plus pole (+) facing upward. Push the battery from above until you hear the click to fit it in the battery holder.

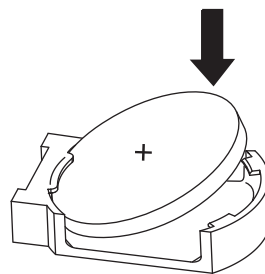

IMPORTANT

- Be sure the battery's plus(+) and minus(-) sides are correctly oriented.

- (4) With the panel computer, install the control box on the front module. With the PL-3000B series unit, install the switch cover back on the control box.

7 | Built-in Options

1. DVD Drive Unit
2. Battery Unit

This chapter provides supplementary information on built-in options available for the PL unit.

7.1 DVD Drive Unit

This section provides information on the PL unit in which our DVD drive unit or DVD multi drive unit is built-in.

IMPORTANT

- Do not remove the DVD drive unit from the DVD drive unit.

7.1.1 Specifications

■ Performance Specifications

	DVD-ROM drive type	DVD multi drive type
Supported media	CD/DVD-ROM, DVD-VIDEO	CD/DVD-ROM, DVD-VIDEO, CD-R/RW, DVD-R/-RW, DVD+R/+RW, DVD-RAM
Reading speed	CD: Max. 24x / DVD: Max. 8x	
Interface	Connected to the slave IDE/ATAPI.	

■ Environmental Specifications

The specification values in the table below are those when the DVD drive unit is built-in to the PL unit.

		DVD-ROM drive type	DVD multi drive type
Physical	Surrounding Air Temperature	5 to 50°C	5 to 50°C : reading 5 to 45°C : writing
	Storage Temperature	-20 to +60°C	
	Ambient Humidity	10 to 90%RH (Not condensing, wet bulb temperature: 29°C or less.)	
	Storage Humidity	10 to 90%RH (Not condensing, wet bulb temperature: 39°C or less.)	
Mechanical	Vibration Resistance *1	Without HDD IEC/EN61131-2 compliant 5 to 9 Hz single-amplitude 3.5mm [0.14in.] 9 to 150 Hz constant-acceleration 9.8m/s ² X, Y, Z directions for 10 cycle (100 minute) With HDD 10 to 57 Hz single-amplitude 0.075mm [0.003in.] 57 to 150 Hz constant-acceleration 9.8m/s ² X, Y, Z directions for 10 cycle (80 minute)	
Electrical	Noise Immunity	Noise Voltage: 1500V _{p-p} Pulse Duration: 50ns, 500ns, 1μs Rise Time: 1ns (via noise simulator)	
	Electrostatic Discharge Immunity	6kV (complies with IEC/EN 61000-4-2 Level 3)	

*1 DVD drive unit to spin the disk, the Vibration Resistance is 1.96m/s² during DVD drive unit's read/write running.

■ System Set Switch

IMPORTANT

- Do not change the default settings on the PL's System Set Switch (SW1) No.8.

PL which has a built-in DVD drive unit has the System Set Switch (SW1) No.8 already correctly set before shipment as follows. PL can be caused to malfunction if you change it.

	No. 8 System Set Switch (SW1)
DVD-ROM drive type	ON
DVD-ROM multi drive type	No Revision: OFF Rev. A, B: ON



3.4.1. Internal switches of the control box (page 3-16)

7.1.2 Dimensions (DVD drive unit built-in)

The following dimensional drawings apply to the control box in which the DVD drive unit is built-in.

For the panel computer, the DVD drive unit is installed on the rear face. A depth for the DVD drive unit is required. See these dimensional drawings together with those of other PL models.

SEE → 4. Dimensions (page 4-1)

■ Dimensions of the 2 slot Unit

Unit: mm [in.]

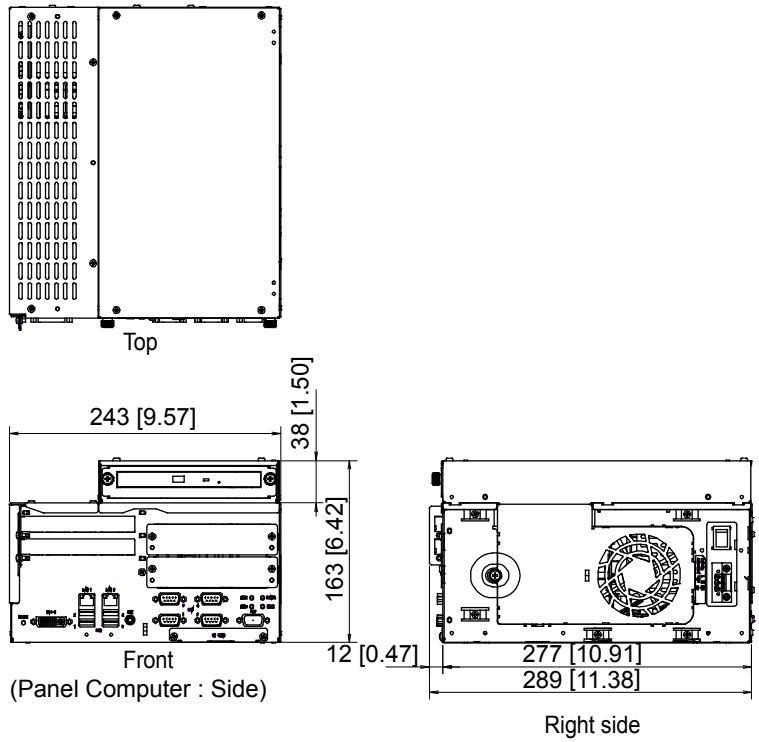

■ Dimensions of the 4 slot unit

Unit: mm [in.]

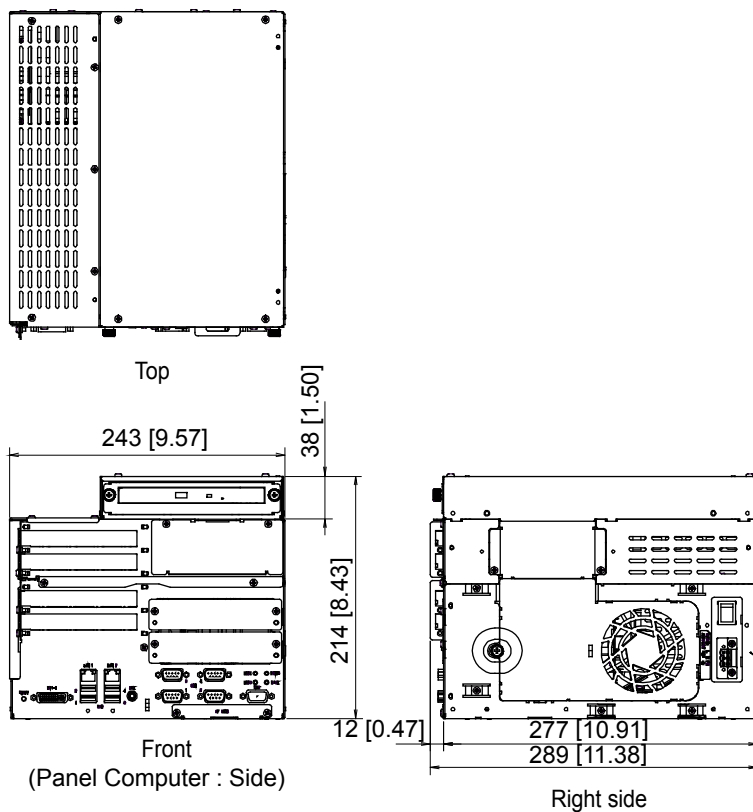

■ Dimension of the Screw Holes

When vertically mounting the PL-3000B series unit in which the DVD drive unit is built-in, drill the attachment holes in the installation panel according to the following dimensional drawings. When mounting the PL unit horizontally or on a wall, the positions of the holes are the same as in the case that the drive unit is NOT built-in.

Use M4 screws to install the PL unit on the installation panel.

SEE → 4.1.4 Dimensions of the Screw Holes (page 4-7)

Unit: mm [in.]

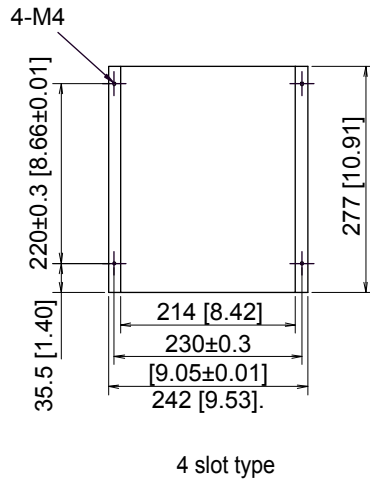
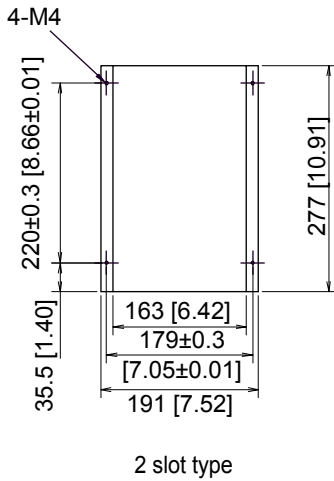





7.2 Battery Unit

This section provides information on PL unit with a built-in battery unit.

7.2.1 Caution

DANGER

Battery



-  To prevent the battery from leakage, heat generation or explosion, be sure and:
 -  Do not heat or throw the battery into a fire.
 -  Do not disassemble or modify the battery.
-  If the battery liquid, strong alkaline, gets in your eyes, immediately rinse your eyes with clean water and consult a doctor, since it may cause you to lose your eyesight.

WARNING

Maintenance



-  The PL unit with a Built-in Battery Unit Version has a Ni-H as a backup battery for system backup. Be extremely careful in using a backup battery in an appropriate way. Using it with an inappropriate way may cause heat generation, fire, leakage, explosion, and blowout.



Battery

-  Do not get the battery wet in fresh or salt water. Doing so may cause battery heat generation and rust. If rust in the battery is found, the function of the gas blowdown valve may not work properly. Moreover, continued use of the battery in this situation may cause an explosion.
-  Do not scratch or remove the outer covering tube. Doing so may cause the battery leakage, heat generation, and an explosion.
-  If the battery liquid, strong alkaline, contacts your skin and clothes, be sure to wash it with clean water. Otherwise, cause skin lesions.

CAUTION

Battery

-  Do not strike or throw the battery. Doing so may cause battery leakage, heat generation, and an explosion.
-  Do not carry the battery while holding the connector and the lead wire. Doing so may cause battery damage.

-  Avoid leaving the battery in high temperature places such as direct sunlight, inside a sun-heated car, near water, or near a heater. Doing so may cause battery leakage, or reduce the battery functions and lifetime.
-  The battery can be recycled. To recycle your used battery, follow the regulations and instructions in your area.

7.2.2 Specification

The specifications differ between models with or without the built-in battery unit.

This section describes specification differences in the PL Unit with a built-in Battery Unit.

■ General Specifications

For General Specification, see “*Chapter 3 Specifications (page 3-1)*”.

However, surrounding air temperature and the weight of the battery unit are shown below.

Surrounding Air Temperature	5 to 45 °C
Weight (the battery unit only)	1.4kg or less

■ Disk Access lamp

When the battery is working, the disk access LED is lit Orange.

LED	Indicates
Green (lit)	When HDD or IDE is accessed
Not lit	When neither HDD nor IDE is accessed
Orange (lit)	Battery working

■ Serial Interface

COM2 is not available on the built-in battery unit version because that version uses COM2 exclusively as an interface for battery output.

7.2.3 Backup Battery

The battery unit is equipped with a Ni-H battery for backup.

■ Charging time

It takes 15 hours for the battery to become fully charged from empty with the power on.

IMPORTANT

- If the PL unit is not used for an extensive period of time, or during initial stage of new installation of the PL unit, the backup battery be insufficiently charged. The battery must be fully charged with the unit powered on AC for 15 hours or more. If the battery is insufficiently charged, the backup battery function may not work properly.

■ Service life

Conditions for the battery	Service life (years)
Hours of use per a day: 24 hours (continuous use) Discharge: 50W 3 minutes discharge, 5 times per year Surrounding air temperature: 30°C	about 3

IMPORTANT

- The service life of the battery varies depending on its usage condition. The values shown above do not guarantee your battery's service life. It is strongly recommended that the battery be replaced with a new one as early as possible.

7.2.4 Replacing Battery Unit

When battery replacement is needed, replace the whole battery unit. The model type of the replacement battery unit is "APL3000-BATTU".

Please refer to the Installation Guide included with the Replacement Battery Unit.

7.2.5 Installation prerequisites for standards

UL/c-UL standards differ between models with or without the built-in battery unit.

- UL recognized components

Information Technology Equipment - Safety - Part 1	refer to UL60950-1	see [a] in the "Product List"
--	--------------------	-------------------------------

- c-UL recognized components

Information Technology Equipment - Safety - Part 1	refer to CSA-C22.2, No.60950-1-03	see [b] in the "Product List"
--	-----------------------------------	-------------------------------

- Product List

<Built-in Battery Unit Version>

Product Model No.	Registration Model No.	UL	c-UL
		[a]	[b]
APL3000-BA	3582302-02	✓	✓
APL3600-TA	3582302-02 Front Module:3620003-01	✓	✓
APL3700-TA	3582302-02 Front Module:3620003-02	✓	✓
APL3900-TA	3582302-02 Front Module:3620003-03	✓	✓
APL3600-KA	3582302-02 Front Module:3620003-04	✓	✓
APL3700-KA	3582302-02 Front Module:3620003-05	✓	✓

UL/c-UL File No.: E171486

<Built-in Battery Unit or DVD Unit Version>

Product Model No.	Registration Model No.	UL	c-UL
		[a]	[b]
APL3000-BA	3582302-03	✓	✓
APL3600-TA	3582302-03 Front Module:3620003-01	✓	✓
APL3700-TA	3582302-03 Front Module:3620003-02	✓	✓
APL3900-TA	3582302-03 Front Module:3620003-03	✓	✓
APL3600-KA	3582302-03 Front Module:3620003-04	✓	✓
APL3700-KA	3582302-03 Front Module:3620003-05	✓	✓

UL/c-UL File No.: E171486

After-sales service

For details on after-sales service, refer to Pro-face website at <http://www.pro-face.com/trans/en/manual/1001.html>.