

PS-3650A/PS-3651A Series Hardware Manual



Preface

Thank you for purchasing a Pro-face PS-3650A/PS-3651A Series Unit (Hereafter referred to as the PS-A unit). Before operating your PS-A unit, be sure to read this manual to familiarize yourself with the PS-A unit's operation procedures and functions.

NOTICE

1. Copying this manual's contents, either in whole or in part, is prohibited without the express permission of Digital Electronics Corporation, Japan.
2. The information contained in this manual is subject to change without notice.
3. If you find any errors or omissions in this document, please contact Digital Electronics Corporation to report your findings.
4. Regardless of Clause 3 above, Digital Electronics Corporation shall not be held responsible for any damage, losses or third-party damage resulting from the use of this product.

Product names used in this manual are the trademarks / registered trademarks of their respective owners.





© 2009 Digital Electronics Corporation. All rights reserved.

Essential Safety Precautions

All safety-related procedures stated in this document must be followed to operate the PS-A unit correctly and safely. Be sure to read this and any related documents thoroughly to understand the correct operation and functions of the PS-A unit.





Safety Icons

Throughout this manual, these icons provide essential safety information for PS-A unit operation procedures requiring special attention. These icons indicate the following levels of danger:

 WARNING	Indicates situations where severe bodily injury, death or major equipment damage can occur.
 CAUTION	Indicates situations where slight bodily injury or minor equipment damage can occur.
	Indicates actions or procedures that should NOT be performed.
	Indicates actions or procedures that MUST be performed to ensure correct unit operation.

WARNING

System Design

-  Do not create PS-A unit touch panel switches that could possibly endanger the safety of personnel or equipment. A malfunction of the PS-A unit, its I/O unit(s), cable(s), or other related equipment can cause unexpected output signals, leading to a serious accident. Be sure to design all important machine operation switches so they are operated via a separate control system, and not via the PS-A unit.
-  Do not create PS-A unit touch panel switches to control machine safety operations, such as an emergency stop switch. Install these switches as separate hardware switches, otherwise severe bodily injury or equipment damage can occur.
-  Be sure to design your system so that a communication fault between the PS-A unit and its host controller will not cause equipment to malfunction. This is to prevent any possibility of bodily injury or equipment damage.
-  Do not use the PS-A unit as a warning device for critical alarms that can cause serious operator injury, machine damage or can halt system operation. Critical alarm indicators and their control/activator units must be designed using stand-alone hardware and/or mechanical interlocks.
-  Do not use the PS-A unit with aircraft control devices, aerospace equipment, central trunk data transmission (communication) devices, nuclear power control devices, or medical life support equipment, due to these devices' inherent requirements of extremely high levels of safety and reliability.

⚠ When using the PS-A unit with transportation vehicles (trains, cars, and ships), disaster and crime prevention devices, various types of safety equipment, and medical devices that are not life-support related, use redundant and/or failsafe system designs to ensure proper reliability and safety.

⊘ After the PS-A unit's backlight burns out the touch panel is still active, unlike the PS-A unit's "Standby Mode". If the operator fails to notice that the backlight is burned out and touches the panel, a potentially dangerous machine operation error can occur. Therefore, do not create PS-A unit touch panel switches that may cause injury and/or equipment damage.

If your PS-A unit's backlight suddenly turns OFF, use the following steps to determine if the backlight is actually burned out.

- 1) If the PS-A unit's "Backlight Control" is not set and the screen has gone blank, your backlight is burned out.
- 2) If the PS-A unit's "Backlight Control" is set to Standby Mode and the screen has gone blank, and touching the screen or performing another input operation does not cause the display to reappear, your backlight is burned out.

Handling

⊘ Do not modify the PS-A unit. Doing so may cause a fire or an electric shock.

⊘ Do not operate the PS-A unit in an environment where flammable gases are present, since it may cause an explosion.

Wiring

⚠ To prevent an electric shock be sure to disconnect your PS-A unit's power cord from the power supply before wiring the PS-A unit.

⊘ Do not use voltage beyond the PS-A unit's specified range. Doing so may cause a fire or an electric shock.

Maintenance

⊘ Do not connect or disconnect Host and PS-A unit communication cables while the PS-A unit is turned ON.

⊘ The PS-A unit uses a lithium battery for backing up its internal clock data and the battery may explode if it is replaced incorrectly. When replacement is required, use a Pro-face-designated replacement product.



SEE → 4.6 Replacing the Internal Battery (page4-15)

CAUTION

Installation

-  Be sure all cable connectors are securely attached to the PS-A unit. A loose connection may cause incorrect input or output signals.

Wiring

-  Be sure to ground the PS-A unit's FG wire separately from other equipment FG lines. Also, be sure to use a grounding resistance of 100Ω or less and a 2mm² or thicker wire, or your country's applicable standard. Otherwise, electric shock or malfunctions may result.
-  Be sure to use only the designated torque to tighten the PS-A unit's terminal block screws. If these screws are not tightened firmly, it may cause a short-circuit, fire or incorrect unit operation.
-  Be sure that metal particles and wiring debris do not fall inside the PS-A unit. They can cause a fire, malfunction or incorrect unit operation.







Maintenance

-  Do not reset or turn the PS-A unit OFF, or insert or remove the CF Card while the PS-A unit's CF Card or hard disk is being accessed. Otherwise, CF Card and the hard disk internal data may be damaged or lost.

Unit Disposal

-  When the product is disposed of, it should be disposed of in a manner appropriate to, and in accordance with, the user country's industrial machinery disposal/recycling standards.

General Safety Precautions

-  Do not press on the PS-A unit's display with excessive force or with a hard object, since it can damage the display. Also, do not press on the touch panel with a pointed object, such as the tip of a mechanical pencil or a screwdriver, since doing so can damage the touch panel.
-  Do not install the PS-A unit where the ambient temperature exceeds the specified range. Doing so may cause a unit malfunction.
-  To prevent abnormally high temperatures from occurring inside the PS-A unit, do not restrict or block the PS-A unit's rear-face ventilation slots.
-  Do not operate the PS-A unit in areas where large, sudden temperature changes can occur. These changes can cause condensation to form inside the PS-A unit, possibly causing it to malfunction.
-  Do not allow water, liquids or metal fragments to enter inside the PS-A unit's case, since they can cause either a malfunction or an electric shock. For use in Pollution Degree 2 environment.
-  Do not operate or store the PS-A unit in locations where it can be exposed to direct sunlight, high temperatures, excessive dust, moisture or vibration.



- ⊘ Do not operate or store the PS-A unit where chemicals evaporate, or where chemicals are present in the air.
 - Corrosive chemicals : Acids, alkalines, liquids containing salt
 - Flammable chemicals : Organic Solvents
- ⊘ Do not use paint thinner or organic solvents to remove dirt or oil from the PS-A unit's surface. Instead, use a soft cloth moistened with a diluted neutral detergent.
- ⊘ Do not use or store the PS-A unit in areas with direct sunlight, since the sun's ultraviolet rays may cause the LCD's quality to deteriorate.
- ⚠ Do not store the PS-A unit in an area where the temperature is lower than that recommended in the PS-A unit's specifications. Doing so may cause the LCD display's liquid to congeal, which can damage the LCD. Also, if the storage area's temperature becomes higher than the specified level, the LCD's liquid may become isotropic, causing irreversible damage to the LCD. Therefore, only store the PS-A unit in areas where temperatures are within the PS-A unit's specifications.
- ⚠ After turning OFF the PS-A unit, be sure to wait at least 5 seconds before turning it ON again. The PS-A unit may not operate correctly if it is restarted too quickly.
- ⚠ Due to the possibility of unexpected accidents, be sure to back up the PS-A unit's data regularly.

LCD Panel Usage Precautions

- The LCD panel's liquid contains an irritant. If the panel is damaged and any of this liquid contacts your skin, immediately rinse the area with running water for at least 15 minutes. If the liquid gets in your eyes, immediately rinse your eyes with running water for at least 15 minutes and consult a doctor.
- The PS-A unit's LCD screen may flicker or show unevenness in the brightness of certain images or at some contrast settings. This is an LCD characteristic and not a product defect.
- Some LCD screens may have differences in brightness and tone. Please be aware of this difference when using multiple units side by side.
- Depending on the ambient temperature, LCD screens may sometimes look whitish (at high temperatures) or blackish (at low temperatures). This is an LCD characteristic and not a product defect.
- Some of PS-A unit's LCD screens may contain light and dark pixels. This is an LCD characteristic and not a product defect.
- Extended shadows, or "Crosstalk" may appear on the LCD screen. This is an LCD characteristic and not a product defect.
- The color displayed on the PS-A unit's LCD screen may appear different when seen from outside the specified viewing angle. This is an LCD characteristic and not a product defect.
- When the same image is displayed on the PS-A unit's screen for a long period, an afterimage may appear when the image is changed. This is an LCD characteristic and not a product defect.
- To prevent an afterimage:
 - Set the PS-A unit's display OFF feature when you plan to display the same screen image for a long period of time.
 - Change the screen image periodically and try to not display the same image for a long period of time.

Information Symbols

This manual uses the following icons:

	Indicates a warning or a product limitation. Be sure to follow the instructions given with this icon to ensure the safe operation of the PS-A unit.
	Contains additional or useful information.
(1) (2)	Indicates steps used to accomplish a given task. Be sure to follow these steps in the order they are written.
*	Indicates useful or important supplemental information.
	Indicates pages containing related information.

About the Manuals

For the detailed information on PS-A series, refer to the following manuals.

- PS-3650A/PS-3651A Series Hardware Manual
- PS-3650A/PS-3651A Series Reference Manual
- PS-3650A/PS-3651A Series API Reference Manual
- Installation Guides for various optional items



- PS-A specifications may change when optional items are used. Check the optional item installation guides' specifications for variances, if any.

The manuals can be downloaded from Pro-face Home Page, "Otasuke Pro!".

"Otasuke Pro!" URL

<http://www.pro-face.com/otasuke/>

PS-3650A/PS-3651A Series Model Names

The term "PS-3650A/PS-3651A" Series refers to the following model numbers:

Series	Models	Type
PS-3650A Series	PS3650A-T42	PS-3650A Series AC Power Supply Type
	PS3650A-T42S	
	PS3650A-T42-24V	PS-3650A Series DC Power Supply Type
	PS3650A-T42S-24V	
PS-3651A Series	PS3651A-T42	PS-3651A Series AC Power Supply Type
	PS3651A-T42S	
	PS3651A-T42-24V	PS-3651A Series DC Power Supply Type
	PS3651A-T42S-24V	

NOTE

- For the models other than the above listed PS-3650A/PS-3651A Series, please refer to the following PDF manual:

"PS-3650A/PS-3651A Series User Manual"

The manuals can be downloaded from the Pro-face home page.

<http://www.pro-face.com/otasuke/>

PS-3650A/PS-3651A Series Model Name Indication

Model name

PS365 $\frac{*}{a}$ A-T42 $\frac{*}{b}$ - $\frac{*}{c}$

a	0	PCI expansion slot type
	1	Fan less type
b	none	RAS port type
	S	Serial 2 port type
c	none	AC Power Supply Type
	24V	DC Power Supply Type

Package Contents

The following items are included in the PS-A unit's package. Before using the PS-A unit, please check that all items listed here are present.

PS-A Unit (1)

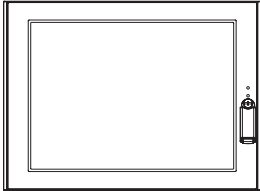

Installation Gasket (1)
(Attached to the PS-A unit)

English and Japanese
Installation Guides (one of each)

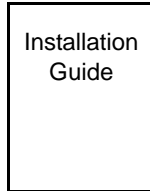

Installation Fasteners (4/set)

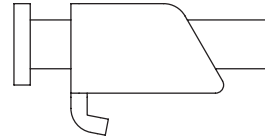

USB Holder (2) sets
(USB Holder (1) + USB Cover (2)) x 2



Power Plug (1)
(Attached to the PS-A unit)

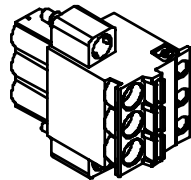
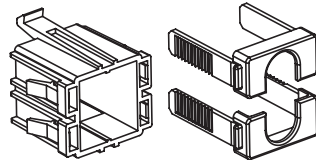

AC Power Supply
Type 5.08mm
[0.2 in.] pitch

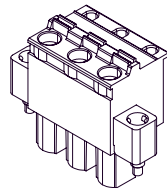

DC Power Supply
Type 7.62mm
[0.3 in.] pitch

NOTE

- If your PS-A unit contains a built-in accessory, that accessory's Installation Guide will also be included in the PS-A unit's packing box. Please check that all items normally included with that accessory are also included in this box.

This unit has been carefully packed, with special attention to quality. However, should you find anything damaged or missing, please contact your local PS-A distributor immediately.

Installation prerequisites for standards

- UL listed products

Industrial Control Equipment	refer to UL508	see [a] in the "Product List"
------------------------------	----------------	-------------------------------

- c-UL listed products

Process Control Equipment	refer to CSA-C22.2 No.142	see [b] in the "Product List"
---------------------------	---------------------------	-------------------------------

- Product List

Product Model No.	Registration Model No.	UL	c-UL
		[a]	[b]
PS3650A-T42	3480801-02	✓	✓
PS3650A-T42S		✓	✓
PS3651A-T42	3480801-01	✓	✓
PS3651A-T42S		✓	✓
PS3650A-T42-24V	3480801-12	✓	✓
PS3650A-T42S-24V		✓	✓
PS3651A-T42-24V	3480801-11	✓	✓
PS3651A-T42S-24V		✓	✓

UL/c-UL File No.: E220851

For the detailed certification's information, refer to the Pro-face Home page.

<Cautions>

Be aware of the following items when building the PS-A into an end-use product:

- The PS-A unit's rear face is not approved as an enclosure. When building the PS-A unit into an end-use product, be sure to use an enclosure that satisfies standards as the end-use product's overall enclosure.
- The PS-A unit must be used indoors only.
- Install and operate the PS-A with its front panel facing outwards.
- If the PS-A is mounted so as to cool itself naturally, be sure to install it in a vertical panel. Also, it's recommended that the PS-A should be mounted at least 50 mm [1.97 in.] away from any other adjacent structures or machine parts. The temperature must be checked on the final product in which the PS-A is installed.
- For use on a flat surface of a Type 4X (Indoor Use Only) and/or Type 12 Enclosure.
- Type 4X (Indoor Use Only) and/or 12 Enclosure, when the hatch for Front USB Port is secured by screw.
Type 1 Enclosure, when the hatch for Front USB Port is open.
- The temperature rating of field installed conductors: 75 °C only.

The safety certificate can be downloaded from Pro-face Home Page.

Home Page URL

<http://www.pro-face.com/>

CE Marking

PS3650A-T42, PS3650A-T42S, PS3651A-T42, PS3651A-T42S, are CE marked products that conform to EMC directives and Low-voltage directive.

PS3650A-T42-24V, PS3650A-T42S-24V, PS3651A-T42-24V, PS3651A-T42S-24V are CE marked products that conform to EMC directives.

For the detailed information on CE Marked, be downloaded and refer the Declaration of Conformity from Pro-face Home Page.

Home Page URL

<http://www.pro-face.com/>

FCC Statement

United States FCC Part 15, Subpart B, Class A EMI Compliance Statement:

NOTE: This equipment has been tested and found to comply with the limits for a Class A digital device, pursuant to part 15 of the FCC Rules. These limits are designed to provide reasonable protection against harmful interference when the equipment is operated in a commercial environment. This equipment generates, uses, and can radiate radio frequency energy and, if not installed and used in accordance with the instruction manual, may cause harmful interference to radio communications. Operation of this equipment in a residential area is likely to cause harmful interference in which case the user will be required to correct the interference at his or her own expense.

Contents

Preface	1
Essential Safety Precautions	2
Information Symbols	6
About the Manuals	6
PS-3650A/PS-3651A Series Model Names	7
PS-3650A/PS-3651A Series Model Name Indication.....	7
Package Contents	8
Installation prerequisites for standards	9
CE Marking	10
FCC Statement	10
Contents	11
Chapter 1 Overview	
1.1 System Design.....	1-2
1.2 Accessories	1-3
1.2.1 Optional Item	1-3
1.2.2 Maintenance Items	1-3
1.3 Part Names and Functions	1-4
1.4 Prior to Operating the PS-A Unit.....	1-7
1.4.1 Front Access Mask	1-7
1.4.2 Power Supply.....	1-7
Chapter 2 Specifications	
2.1 General Specifications	2-2
2.1.1 Electrical	2-2
2.1.2 Environmental.....	2-2
2.1.3 Structural.....	2-4
2.2 Performance Specifications	2-5
2.2.1 Performance Specifications	2-5
2.2.2 Display	2-7
2.2.3 Touch Panel	2-7
2.2.4 Expansion Slot.....	2-7
2.3 Interface Specifications.....	2-8
2.3.1 Serial Interfaces (COM1/COM2).....	2-8
2.3.2 RAS Interface (RAS).....	2-11
2.4 DIP Switches	2-14
2.5 Dimensions	2-20

2.5.1 PS-3650A Series External Dimensions	2-20
2.5.2 PS-3651A Series External Dimensions	2-22
2.5.3 Panel Cut Dimensions	2-23
2.5.4 Installation Fasteners.....	2-23

Chapter 3 Installation and Wiring

3.1 Installation.....	3-2
3.1.1 Installation Procedures	3-2
3.2 Peripheral Devices Installation	3-7
3.2.1 Main Memory Installation	3-7
3.2.2 PCI Board Installation	3-9
3.2.3 PCMCIA (PC Card) Installation/Removal	3-11
3.2.4 CF Card Insertion/Removal	3-12
3.2.5 HDD Unit Installation.....	3-14
3.2.6 USB Holder Attachment/Removal.....	3-17
3.3 Wiring Precautions.....	3-19
3.3.1 Connecting the Power Cord.....	3-19
3.3.2 Connecting the Power Supply.....	3-23
3.3.3 Grounding	3-24
3.3.4 I/O Signal Line Placement	3-24

Chapter 4 Maintenance

4.1 Cleaning the Display.....	4-2
4.2 Cleaning the Fan Filter	4-3
4.3 Periodic Check Points.....	4-5
4.4 Replacing the Installation Gasket	4-6
4.5 Replacing the Backlight	4-8
4.5.1 Backlight Replacement Procedure for PS-3650A Series.....	4-9
4.5.2 Backlight Replacement Procedure for PS-3651A Series.....	4-12
4.6 Replacing the Internal Battery	4-15

1 | Overview

1. System Design
2. Accessories
3. Part Names and Functions
4. Prior to Operating the PS-A Unit

This chapter describes peripheral devices that can be connected to PS-A Series units, as well as the names and functions of the PS-A Series components.

1.1 System Design

The following diagram illustrates the standard range of items that can be connected to the PS-A unit.

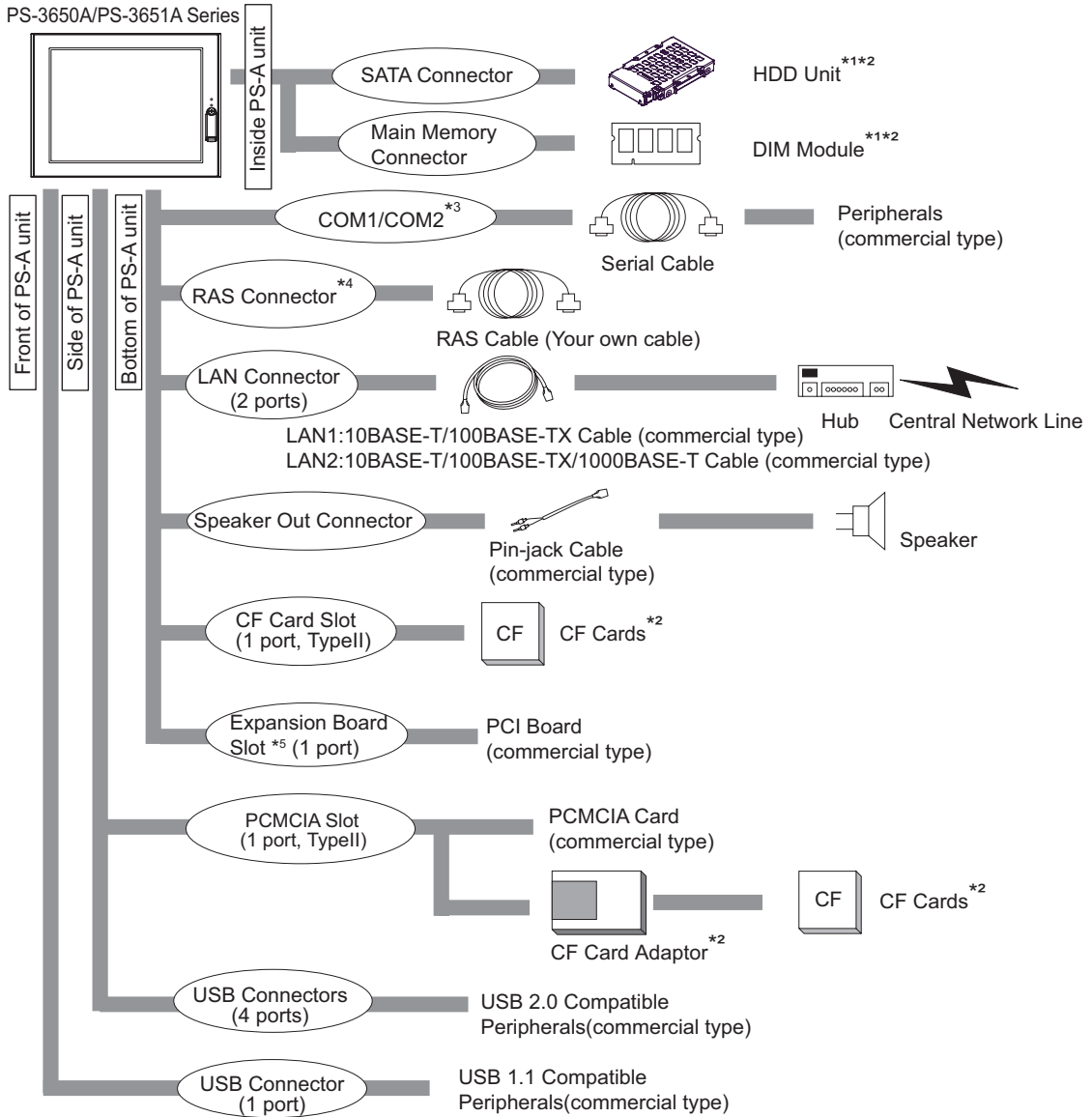

*1 Built-in accessory only

*2 The Pro-face's optional devices used with the PS-A. Please refer to "1.2 Accessories" for details.

*3 COM2 is an interface for Serial 2 port type model only.

*4 RAS is interface for RAS port type model only.

*5 PS-3651A Series does not have an expansion board slot. PS-3650A Series only does.

IMPORTANT

- This diagram shows only the PS-A unit's internal layout and connectable devices. The user's actual design may differ.

1.2 Accessories

All accessories listed here are produced by Pro-face.

1.2.1 Optional Item

Product Name	Model No.	Description
DIM module	PSA-DDR512	Memory module 512MB
	PSA-DDR1G	Memory module 1GB
Hard Disk Unit	PS365XA-HD60	HDD Unit mounted a Type 2.5 Hard Disk (60GB without OS)
	PS365XA-HD250	HDD Unit mounted a Type 2.5 Hard Disk (250GB without OS)
CF Card	CA3-CFCALL/128MB-01	Type 1 128MB
	CA3-CFCALL/256MB-01	Type 1 256MB
	CA3-CFCALL/512MB-01	Type 1 512MB
	CA6-CFCALL/1GB-01	Type 1 1GB
	CA8-CFCALL/2GB-01	Type 1 2GB
CF Card Adapter	GP077-CFAD10	Used for read/write of CF Card data via a PS-A unit's PCMCIA slot.

1.2.2 Maintenance Items

Product Name	Model No.	Description
Installation Fastener	CA3-ATFALL-01	Used to install the PS-A unit into a solid panel (4 pieces per a set).
Installation Gasket	CA3-WPG12-01	Provides dust and moisture resistance when PS-A unit is installed into a solid panel.
Replacement Backlight	CA8-BLU12XGA-01	Backlight for replacement
Protective panel sheet	CA5-DFS10-01	Disposable sheet that protects the PS-A unit's screen from dust. (5 sheets/set) (Hard type)
DC Power Supply Connector (Straight)	CA7-DCCNL-01	DC Power Supply Connector (5 connectors/set)
AC Power Supply Connector (Straight)	CA7-ACCNL-01	AC Power Supply Connector (5 connectors/set)

1.3 Part Names and Functions

The following images are of a PS-3650A/PS-3651A Series unit.

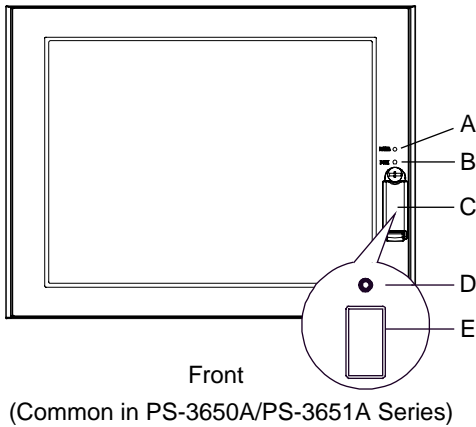

A: Power LED / RAS Status lamp (POWER)

This status LED indicates the power current and operation status. The following table shows the display colors and corresponding status.

LED	Status
Green (lit)	Normal operation (power is ON).
Green (blinking)	System is NOT running (Soft OFF state).
Orange (lit)	System monitor error.
Orange/ Red (blinking)	Backlight error.
Not lit	Power is OFF.

B: HDD/IDE Access lamp (DISK)

LED	Status
Green (lit)	HDD or IDE is accessed.
Not lit	Neither HDD nor IDE is accessed.
Orange (lit)	PS-A unit is in operation with backup battery
Red (lit)	PS-A unit is in operation with backup battery

C: Front Cover

D: Hardware Reset Switch (RESET)

E: Front USB Interface (USB)

1 port, USB 1.1 Compatible.

Uses a "Type-A" connector.

Power supply voltage	DC5V ±5%
Output current	Each port: 500mA (max.) 4 ports total: 500mA (max.)
Maximum communication distance	5m

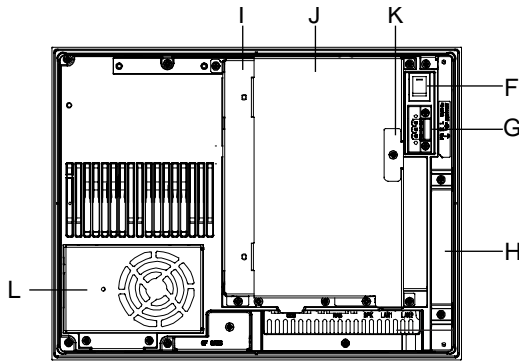

Rear
(PS-3650A Series AC Power Supply Type)

F: Power Switch

AC Power Supply Type only

G: Power Supply Connector

For connection, attach a power plug (included) to the power cable.

H: Mask Cover

I: Expansion Board Base

J: Expansion Board Cover

K: Expansion Board Support

L: Fan Unit

M: Memory Slot Cover

N: DISK Cover

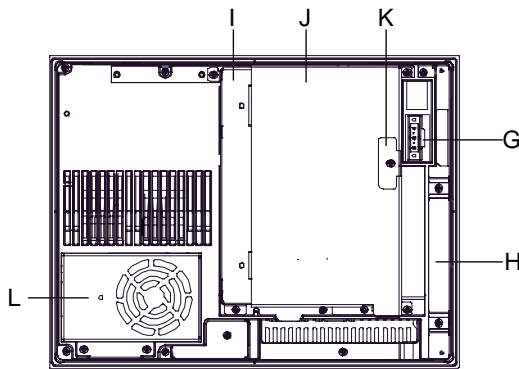

Rear
(PS-3650A Series DC Power Supply Type)

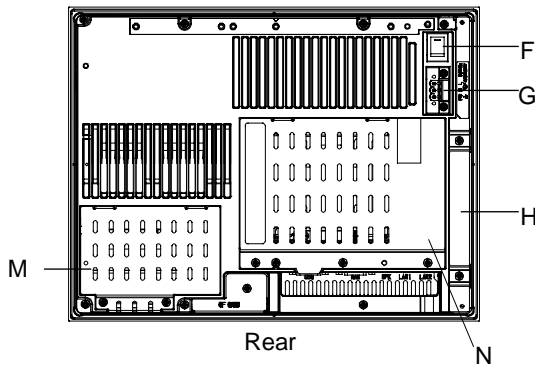

Rear
(PS-3651A Series AC Power Supply Type)

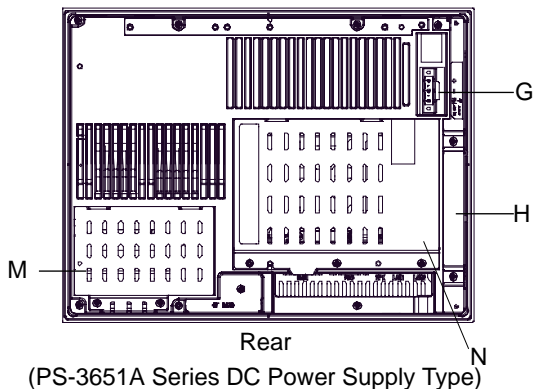

Rear
(PS-3651A Series DC Power Supply Type)

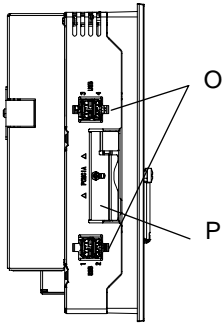

Left Side
(PS-3650A Series)

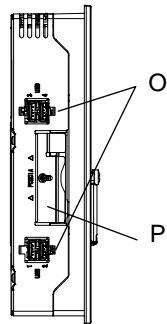

Left Side
(PS-3651A Series)

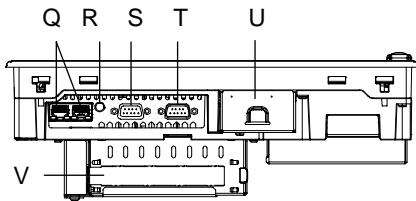

Bottom
(PS-3650A Series)

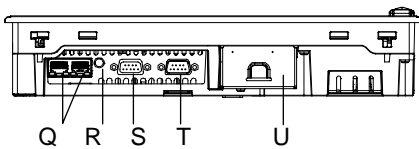

Bottom
(PS-3651A Series)

O: USB Interface (USB)

4 ports, USB 2.0 Compatible.

Uses a "TYPE-A" connector.

Power supply voltage	DC5V ±5%
Output current	Each port: 500mA(max.) 4 ports total: 500mA(max.)
Maximum communication distance	5m

P: PCMCIA Slot Cover

Q: Ethernet Interface (LAN1 / LAN2)

LAN1: 10BASE-T, 100BASE-TX auto changeover

LAN2: 10BASE-T, 100BASE-TX, 1000BASE-T auto changeover

R: Speaker Output Interface (SPEAKER OUT)

Mini pin jack connector.

S: RAS interface (RAS) / Serial Interface (COM2)

RAS port type:

RAS port. D-Sub 9 (socket)

Serial 2 port type:

RS-232C port. D-Sub 9 (plug)

T: Serial Interface (COM1)

RS-232C, RS-422, RS-485 port. D-Sub9 (plug)

U: CF Card Cover

V: Expansion Slot

This is a slot that is mounted on a PCI board.

1.4 Prior to Operating the PS-A Unit

1.4.1 Front Access Mask

When you open the PS-A's front maintenance hatch, there are a front USB port and a Hardware Reset Switch. If you want to restrict access or prevent unintentional access from the Front USB port or Hardware Reset Switch, change the settings of the DIP Switch on the circuit board in PS-A unit for Front Access Mask. See the following for DIP Switch details.

SEE → 2.4 DIP Switches (page2-14)

1.4.2 Power Supply

The PS-A unit's power supply has three states; Non-energized, Active State (Normal), and Soft OFF State^{*1}. Each state is outlined in the following.

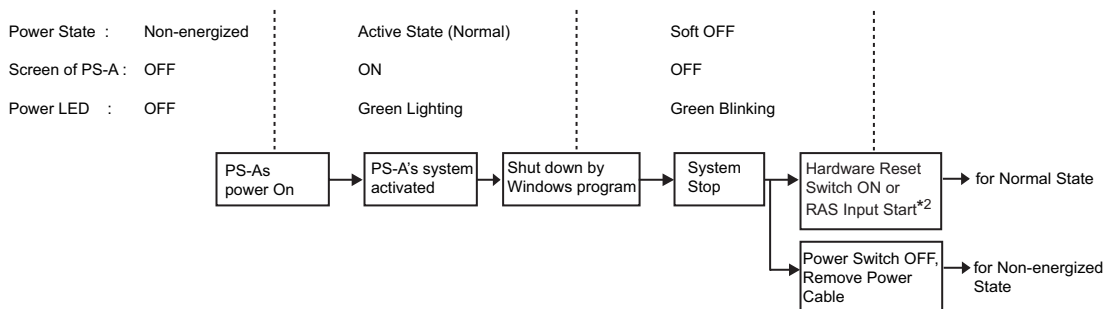

*1 The Soft OFF refers to the state that Windows[®] has been shut down and the power is provided only for the electric circuit to boot system. This Soft OFF State is different from what is System Standby set by Windows[®].

*2 See "■ RAS Input Start (page2-12)" for details. This feature is only available for RAS port type.

2

Specifications

1. General Specifications
2. Performance Specifications
3. Interface Specifications
4. Dimensions

This chapter describes the general, functional, and interface specifications of the PS-A unit, as well as external dimensions.

2.1 General Specifications

2.1.1 Electrical

		PS-3650A/PS-3651A Series AC Power Supply Type (PS3650A-T42/ PS3651A-T42/ PS3650A-T42S/ PS3651A-T42S)	PS-3650A/PS-3651A Series DC Power Supply Type (PS3650A-T42-24V/ PS3651A-T42-24V/ PS3650A-T42S-24V/ PS3651A-T42S-24V)
Power Supply	Input Voltage	AC100/240V	DC24V
	Rated Voltage	AC85 to 265V	DC19.2 to 28.8V
	Rated Frequency	50/60Hz	-
	Allowable Voltage Drop	1 cycle or less (Voltage drop interval must be 1s or more.)	5ms (max.)
	Power Consumption	PS-3650A Series:110VA or less PS-3651A Series:95VA or less	PS-3650A Series:80W or less PS-3651A Series:40W or less
	In-Rush Current	AC100V (room temperature): 30A or less AC240V (room temperature): 50A or less	30A or less (room Temperature)
Voltage Endurance		AC1,500V 20mA for 1 minute (between charging and FG terminals)	AC1,000V 20mA for 1 minute (between charging and FG terminals)
Insulation Resistance		DC500V 10MΩ(min.) (between charging and FG terminals)	

2.1.2 Environmental

		PS-3650A Series	PS-3651A Series
Physical	Surrounding Air Temperature	0 to 50°C: without HDD 5 to 50°C: with HDD	0 to 50°C: without HDD 5 to 45°C: with HDD
	Storage Temperature	-20 to +60°C	
	Ambient Humidity	10%RH to 90%RH (Not condensing, wet bulb temperature: 39°C or less. Wet bulb temperature with HDD: 29°C or less.)	
	Storage Humidity	10%RH to 90%RH (Not condensing, wet bulb temperature: 39°C or less.)	
	Dust	0.1mg/m ³ and below (non-conductive levels)	
	Pollution Degree	For use in Pollution Degree 2 environment	
	Corrosive gas	Free of corrosive gas	
	Atmosphere (Using height)	800 to 1,114hPa (-300 to +2,000m)	

Mechanical	Vibration Resistance	<p>< without HDD > IEC61131-2 compliant 5Hz to 9Hz single-amplitude 3.5mm 9Hz to 150Hz constant-accelerated velocity 9.8m/s² X, Y, Z directions for 10 cycle (100 minutes)</p> <p>< with HDD > 10Hz to 57Hz single-amplitude 0.0375mm 57Hz to 150Hz constant-accelerated velocity 4.9m/s² X, Y, Z directions for 10 cycle (80 minutes)</p>
	Noise Immunity (via noise simulator)	Noise Voltage: 1,500Vp-p (via noise simulator) Pulse Duration: 50ns, 500ns, 1µs Rise Time: 1ns
Electrical	Electrostatic Discharge Immunity	6kV (complies with IEC61000-4-2 Level 3)
Noise Immunity (Fast Transient Burst Noise)		Power supply line: 2kV (IEC61000-4-4) COM port: 1kV (IEC61000-4-4)

IMPORTANT

- When using any of the PS-A unit's optional devices, be sure to check that device's specifications for any special conditions or cautions that may apply to its use.
- Be aware that not only does the Hard Disk/SSD have a fixed lifetime, but that accidents can always occur. Therefore, be sure to back up your Hard Disk/SSD's data regularly, or prepare another Hard Disk/SSD unit that can be used for backup.
- The Hard Disk lifetime given here may be reduced due to unforeseen environmental factors. The following table shows the Hard Disk lifetime general factors.

	PS365XA-HD60	PS365XA-HD250
Factors	Operating temperature: 20°C, 333 hours of operation per month. (HDD access frequency of 20% or less)	Operating temperature: 20°C, 732 hours of operation per month. (HDD access frequency of 50% or less)
Lifetime	20,000 hours (of operation) or approximately 5 years, whichever comes first.	30,000 hours (of operation) or approximately 5 years, whichever comes first.

- Using the Hard Disk in an environment that is excessively hot and/or humid will shorten the disk's usage lifetime. A wet bulb temperature of 29°C or less is recommended. This is equivalent to the following data.

Temperature	at 35°C	at 40°C
Humidity	no higher than 64% RH	no higher than 44% RH

- In order to extend the lifetime of the hard disk, Pro-face recommends you set Windows® to turn the hard disk off when the unit is not being operated. A setting of 5 minutes is recommended.
- Do not vibrate the hard disk continuously at the same frequency. Doing so may cause the hard disk to reduce transfer speeds or stop temporarily.

2.1.3 Structural

		PS-3650A Series	PS-3651A Series
Installation	Grounding	Grounding resistance of 100 Ω, 2mm ² or thicker wire, or your country's applicable standard. (Same for FG and SG terminals)	
	Structure	Rating ^{*1} : Equivalent to IP65f (Only not using Front USB) figuration: Built-in type Installation method: Embedding	
	Cooling Method	Forced cooling by fan	Natural air circulation
	Weight	Approx. 4.5kg [9.9lb] (unit only)	Approx. 3.8kg [8.4lb] (unit only)
	External Dimensions	W313mm [12.32in.] × H239mm [9.41in.] × D103mm [4.06in.]	W313mm [12.32in.] × H239mm [9.41in.] × D60mm [2.36in.]

*1 The front face of the PS-A unit, installed in a solid panel, has been tested using conditions equivalent to the standards shown in the specification. Even though the PS-A unit's level of resistance is equivalent to these standards, oils that should have no effect on the PS-A unit can possibly harm the unit. This can occur in areas where either vaporized oils are present, or where low viscosity cutting oils are allowed to adhere to the unit for long periods of time. If the PS-A unit's front face protection sheet becomes peeled off, these conditions can lead to the ingress of oil into the PS-A unit and separate protection measures are suggested. Also, if non-approved oils are present, it may cause deformation or corrosion of the front panel's plastic cover. Therefore, prior to installing the PS-A unit be sure to confirm the type of conditions that will be present in the PS-A unit's operating environment.

If the installation gasket is used for a long period of time, or if the unit and its gasket are removed from the panel, the original level of the protection cannot be guaranteed. To maintain the original protection level, be sure to replace the installation gasket regularly.

2.2 Performance Specifications

2.2.1 Performance Specifications

		PS-3650A Series	PS-3651A Series
CPU		Intel® Celeron M 1.5GHz	Intel® ULV Celeron M 1GHz
L2 Cache Memory		1MB (Built in the CPU)	512KB (Built in the CPU)
Main Memory		SO-DIMM socket 256MB to 1GB (PC2700)	
Chipset		Intel® 855GME + ICH4	
Graphic Accelerator		Built in Intel® 855GME	
BIOS		FirstBIOS Embedded Pro (Phoenix Technologies Co.)	
Graphics		XGA (1,024 x 768 dots)	
Video Memory		8 to 64MB (UMA method)	
Interface	Serial Interface *1	COM1: RS-232C / RS-422 / RS-485 switched option RS-232C is RI/+5V changeover Connector: D-Sub 9 pin (plug) COM2: RS-232C (RI fixed) Connector: D-Sub 9 pin (plug)	
	Network Interface	LAN1: Realtek RTL8100CL IEEE802.3i / IEEE802.3u 10BASE-T / 100BASE-TX Auto Changeover Connector: Modular Jack (RJ-45) LAN2: Realtek RTL8110SCL IEEE802.3i / IEEE802.3u / IEEE802.3ab 10BASE-T / 100BASE-TX / 1000BASE-T Auto Changeover Connector: Modular Jack (RJ-45)	
	USB Interface	Front face: USB 1.1 (Low/ Full Speed 12 Mbps) x 1 port Side face: USB 2.0 (High Speed 480 Mbps) x 4 ports Connector: USB TYPE-A Power supply voltage: DC5V ±5% Output current: Each port: 500mA (max.), Total 5 ports (Front and Left): 500mA (max.) The maximum communication distance: 5m	
	RAS Interface *2	General-Purpose Input 2ch (DIN1 can be common with external reset input), General-Purpose Output 2ch Connector: D-Sub 9 pin (socket)	
	Speaker Output Interface	Stereo Speaker output Connector: Mini Pin Jack	
	Serial ATA	Serial ATA Rev.1.0 X 1 2.5" HDD Unit	
	IDE	CF Card slot Primary Master or Primary Slave Connector: Type I / II X 1slot	
	PCMCIA	PC Card slot Corresponding to CARD BUS (Excluding ZOOM VIDEO, SOUND functions) Connector: Type II X 1slot	
	PCI	PCI Rev. 2.2 (33MHz)	None
Clock Accuracy *3		± 180 sec. / month (timing error depending on the situation at normal temperature and power-off)	

*1 COM2 is an interface for Serial 2 port type only.

*2 RAS is an interface for RAS port type only.

- *3 The RTC clock built in the PS-A unit has a timing error. The range of the error will be between +300 to -300 sec. / month, depending on the PS-A unit's conditions such as lifetime usage or temperature difference. If you use the PS-A unit in a system that is very dependent on timing, adjust the clock at regular intervals.

2.2.2 Display

Display Type	TFT Color LCD
Resolution	W1,024 x H768 pixels
Dot pitch	W0.24mm [0.01in.] x H0.24mm [0.01in.]
Effective Display Area	W245.76mm [9.68in.] x H184.32mm [7.26in.]
Color/Shade level	262,144 colors
Backlight	CCFL (user replaceable)
Brightness control	4 levels of adjustment
Contrast Adjustment	None
View Angles	Horizontal Direction: 120 degrees, Vertical Direction: 100 degrees (Contrast ratio: CR is 10 or greater, or TYP value)
Backlight Service Life	60,000hrs. or more (at ambient temperature 25°C and continuous operation - period until backlight brightness decreases to 50% or backlight starts to flicker)

2.2.3 Touch Panel

Type	Resistive Film (analog)
Resolution	1,024 x 1,024
Service Life	1,000,000 times or more

2.2.4 Expansion Slot*¹

Slot Type	PCI 2.2 (5V)			
Size	174.63mm [6.88in.] × 106.68mm [4.20in.]			
Output Voltage	DC5V	DC12V	DC-12V	DC3.3V
Consumption Current	1.5A	0.5A	0.1A	0.5A

*¹ Available only for PS-3650A Series.

2.3 Interface Specifications

This section describes the specifications of each interface of the PS-A Series unit.

2.3.1 Serial Interfaces (COM1/COM2)

The PS-A unit side connector is a D-Sub 9 pin plug type.

Use #4-40 (UNC) for connections.

IMPORTANT

- Do not connect any pins to [NC].
- Connect the FG terminal line to the shell.
- This PS-A unit's serial port is not isolated. When the host (PLC) unit is also not isolated, and to reduce the risk of damaging the RS-232C/RS-422/RS-485 circuit, be sure to connect the pin #5 SG (Signal Ground) terminal.
- FG and SG terminals are internally connected in the PS-A unit. When connecting to another device, be sure not to create an SG shorting loop in your system.

■ COM1

COM1 can be changed to RS-232C, RS-422 or RS-485. (The factory setting is RS-232C.) To change this setting, open the PS-A unit's Fan Unit or Memory Slot Cover and set the DIP Switches on the circuit board to the desired position.

SEE → 2.4 DIP Switches (page 2-14)

IMPORTANT

- Make sure to turn off the power supply before using the DIP Switches. Adjusting the DIP Switches while power is supplied may cause malfunction.

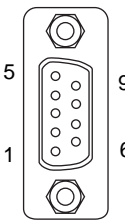
Pin Arrangement	Pin No.	RS-232C		
		Signal Name	Direction	Description
 <p>(PS-A side)</p>	1	CD	Input	Carrier Detect
	2	RD(RXD)	Input	Receive Data
	3	SD(TXD)	Output	Send Data
	4	ER(DTR)	Output	Data Terminal Ready
	5	GND(SG)	-	Signal Ground (SG)
	6	DR(DSR)	Input	Data Set Ready
	7	RS(RTS)	Output	Request to Send
	8	CS(CTS)	Input	Send Possible
	9	CI(RI)/+5V ^{*1}	Input/ Output	Called status display/+5V Output (Switching available)
	Shell	FG	-	Frame Ground (Common with SG)

*1 To change pin #9's RI/+5V setting, open the PS-A unit's Fan Unit or Memory Slot Cover and set the slide Switch to the desired position. Please refer to 2.4 DIP Switches (page 2-14)

Pin No.	RS-422		
	Signal Name	Direction	Description
1	RDA	Input	Receive Data A (+)
2	RDB	Input	Receive Data B (-)
3	SDA	Output	Send Data A (+)
4	NC	-	No Connection
5	GND	-	Signal Ground (SG)
6	NC	-	No Connection
7	SDB	Output	Send Data B (-)
8	NC	-	No Connection
9	NC	-	No Connection
Shell	FG	-	Frame Ground (Common with SG)

Pin No.	RS-485		
	Signal Name	Direction	Description
1	DATA +	Input / Output	Send/Receive Data (+)
2	DATA -	Input / Output	Send/Receive Data (-)
3	NC	-	No Connection
4	NC	-	No Connection
5	GND	-	Signal Ground (SG)
6	NC	-	No Connection
7	NC	-	No Connection
8	NC	-	No Connection
9	NC	-	No Connection
Shell	FG	-	Frame Ground (Common with SG)

■ COM2

This interface is used to connect an RS-232C serial cable.

- NOTE** • COM2 is an interface for Serial 2 port type only.

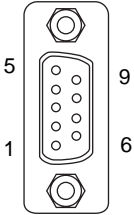
Pin Arrangement	Pin No.	RS-232C		
		Signal Name	Direction	Description
 <p>(PS-A side)</p>	1	CD	Input	Carrier Detect
	2	RD(RXD)	Input	Receive Data
	3	SD(TXD)	Output	Send Data
	4	ER(DTR)	Output	Data Terminal Ready
	5	GND(SG)	-	Signal Ground (SG)
	6	DR(DSR)	Input	Data Set Ready
	7	RS(RTS)	Output	Request to Send
	8	CS(CTS)	Input	Clear to Send
	9	CI(RI)	Input	Called status display
	Shell	FG	-	Frame Ground (Common with SG)

2.3.2 RAS Interface (RAS)

The PS-A unit side connector is a D-Sub 9 pin socket type.

Use #4-40 (UNC) for connections.

NOTE

- RAS is an interface for RAS port type only.

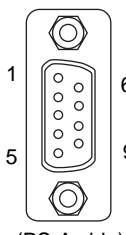
Pin Arrangement	Pin No.	Signal Name	Description
 <p>(PS-A side)</p>	1	+12 V	Output Current: 100mA or less Output Voltage: DC12V±5%
	2	DOUT0(+)	Data out 0(+)
	3	DOUT1(+)	Data out 1(+)
	4	DIN0(+)	Data in 0(+)
	5	DIN1(+)	Data in 1(+) ^{*1}
	6	GND	Ground
	7	DOUT0(-)	Data out 0(-)
	8	DOUT1(-)	Data out 1(-)
	9	DINCOM	Data in common

*1 This pin can be used as the RAS Input Start or the external reset input. The factory setting is General-Purpose Input (Data Input).

IMPORTANT

- Be sure to use only the rated voltage level when using pin # 1 (+12V) for external power output. Failure to do so can lead to unit malfunction or accident.

■ General-Purpose Input (DIN 0, 1)

Input Voltage		DC12V to 24V
Input Method		Sink / Source Input
Input Current		10mA (DC24V)
Input Resistance		3.6kΩ
Input Points		2 points (common with external reset input)
Operation Range	ON voltage	DC10V or more
	OFF voltage	DC3V or less
Isolation Method		Photocoupler Isolation
Dielectric Strength Voltage		500V or more

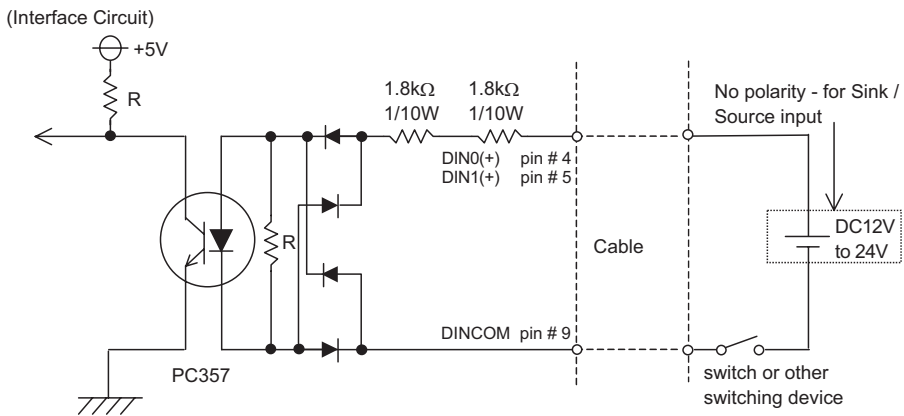

IMPORTANT

- General-Purpose Input (DIN) level must be 1.5 seconds or longer to be detected. It may not detect under 1.5 seconds.
- Be sure the voltage value between terminals is controlled via the input voltage, so that the PS-A unit is operated within its recommended range. If the input voltage exceeds this range, a malfunction or PS-A unit damage may occur.
- The Sink/Source input can be used even if the DIN(-), and RESET(-) are positive, and DIN(+), RESET(+) are negative. Be sure to operate the unit within the recommended voltage range.

■ RAS Input Start

RAS Input Start^{*1 *2} is a function which allows input to DIN1(+) to start the PS-A unit from Hibernate or Soft OFF state.

After the input start, DIN1(+) can be used as General-Purpose Input.

Input signal electric specifications is the same as General-Purpose Input

IMPORTANT

- PS-A unit will be restarted if you shut down Windows[®] during DIN(+)[®] input. To change PS-A unit to Soft OFF state, set DIN1(+)[®] input OFF before shutting down Windows[®].

*1 To use RAS Input Start, set System Set SW 2 No.3 to ON. See "2.4 DIP Switches (page 2-14)" for DIP Switches details.

*2 Available only for RAS port type.

■ General-Purpose Output (DOUT 0, 1)

Rated Voltage	DC12V to 24V
Maximum Load Current	120mA/point
Out Voltage Drop	1.5V or less (at 100mA load current)
Output Points	2 points
Isolation Method	Photocoupler Isolation
Dielectric Strength Voltage	500V or more
External Power Supply	DC12V / 100mA

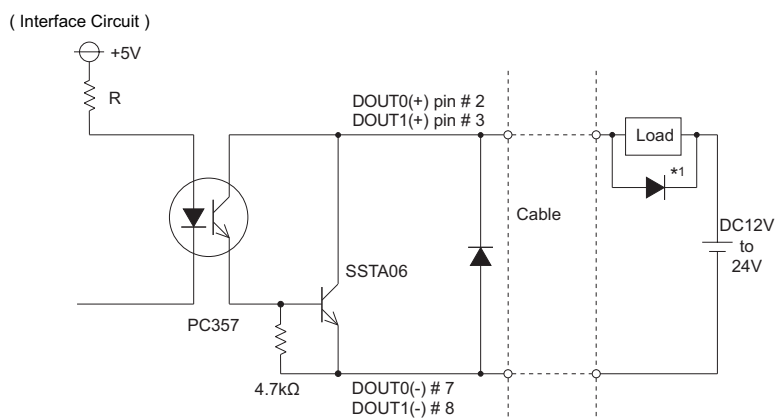

IMPORTANT

- Be sure to operate the unit within its maximum load current. If the maximum load current exceeds this range, a malfunction or PS-A unit damage may occur.
- Design your electrical system by adding the load current and voltage values to the terminal voltage. If load current value used is large, the voltage drop of 1.5V or less will occur between the terminals.
- When connecting an induction load, be sure to connect the protection diode (*1), as shown in the diagram above.

2.4 DIP Switches

The DIP Switches are mounted on the circuit board under the Fan Unit or the Memory Slot Cover. For details on how to remove the Fan Unit or the Memory Slot Cover, refer to the following section.

SEE → 3.2.1 Main Memory Installation (page 3-7)

IMPORTANT

- Make sure to turn off the power supply before using the DIP Switches. Adjusting the DIP Switches while power is supplied may cause a unit malfunction or damage.
- Be sure to confirm which settings will be used by other connected devices and set the DIP Switches accordingly. Failure to do so can result in a unit malfunction or damage.

■ DIP Switch Locations

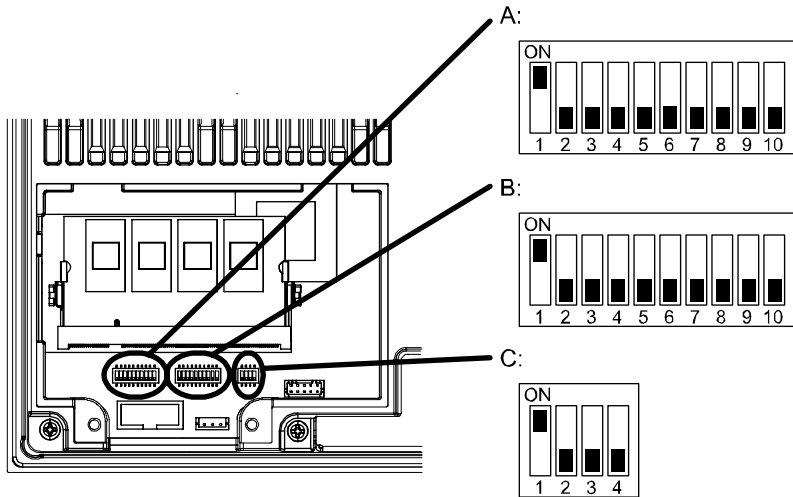

Switch Location	Switch Name	Description
A	System Set SW1	10-point DIP Switch. For the switches details, see ■ System Set SW 1 (page2-15).
B	Serial Mode Select SW	10-point DIP Switch. Designates COM1 communication settings. For the switches details, see ■ Serial Mode Select SW (page2-17).
C	System Set SW2	4-point DIP Switch. For the switches details, see ■ System Set SW 2 (page2-19).

■ System Set SW 1

SW No.	Description	ON	OFF	Notes
1	Used for the system.	Reserved	Reserved	Factory Settings: ON
2	Used for the system.	Reserved	Reserved	Factory Settings: OFF
3	Change Hardware Reset Switch mode.	Power button	Reset SW	Factory Settings: OFF
4	Disable/enable Hardware Reset Switch.	Disabled	Enabled	Factory Settings: OFF
5	Used for the system.	Reserved	Reserved	Factory Settings: OFF
6	Disable/enable Access to the Front USB port.	Disabled	Enabled	Factory Settings: OFF
7	Used for the system.	Reserved	Reserved	Factory Settings: OFF
8	Disable/enable Detecting the middle point during touching two points simultaneously.	Disabled	Enabled	Factory Settings: OFF
9	Used for the system.	Reserved	Reserved	Factory Settings: OFF
10	Changes COM1's # 9 pin (RI <---> +5V). Enabled only when RS-232C mode	+5V Output	RI	Factory Settings: OFF

Table 1) System Set SW 1

◆ Change Hardware Reset Switch mode *1

- Power button mode

When the Hardware Reset Switch on the front of the PS-A unit is pressed, the Windows® power button operation setting is executed.

For Windows® XP, the option selected in [When I press the power button on my computer] from [Control panel]-[Power Options]-[Advanced] occurs.

- Reset SW mode

The PS-A unit restarts when pressing the Hardware Reset Switch on the front of the PS-A unit.

◆ Disable/Enable Hardware Reset Switch *1

When disabled, you cannot reset using Hardware Reset Switch while the system is running.

When enabled, Hardware Reset Switch operates in the mode set on Switch No.3.

*1 In SOFT OFF state, pressing Hardware Reset Switch will start the PS-A unit regardless of settings.

For more details about SOFT OFF state, please refer to 1.4.2 Power Supply (page 1-7).

◆Disable/enable Access to the Front USB port.

When "disabled" is selected, the front USB port cannot be used after you turn on the PS-A unit.

The front USB port is available only for Windows®. Make sure to disable the function when another OS is used.

◆Disable/enable Detecting the middle point during touching two points simultaneously.

When two points are pushed simultaneously, it is considered that middle point between the two points is touched according to the nature of the analog resistive touch panel. If a switch or other part is located on the middle point, it will be detected and may be operated without any touches. To prevent such a switch from malfunction during two points are pushed simultaneously, set Switch Number 8 to ON.

Even, drug control could not be operated very smoothly.

■ Serial Mode Select SW

The factory setting is RS-232C. Only Switch No.1 is set to ON.

Switch No.	Description	ON	OFF	RS-232C	RS-422	RS-485 (Data is not automatically controlled via the RTS signal.) ^{*1}	RS-485 (Data is automatically controlled via the RTS signal.) ^{*1}
1	Changes COM1's communication method	RS-232C	RS-422/ RS-485	ON	OFF	OFF	OFF
2	Changes COM1's communication method	RS-422/ RS-485	RS-232C	OFF	ON	ON	ON
3	Changes COM1's communication method	RS-422/ RS-485	RS-232C	OFF	ON	ON	ON
4	Changes TX data's output mode	TX data output is controlled via the RTS signal.	TX data output is NOT controlled via the RTS signal. (normally output)	OFF	ON/ OFF	ON	OFF
5	Switches the TX termination resistance ON/OFF	Inserts termination resistance of 220Ω between TXA and TXB.	No termination	OFF	ON	ON/OFF ^{*2}	ON/OFF ^{*2}
6	Switches the RX termination resistance ON/OFF	Inserts termination resistance of 220Ω between RXA and RXB.	No termination	OFF	ON	ON/OFF ^{*2}	ON/OFF ^{*2}
7	Switches the shorting of TXA and RXA ON or OFF	Shorts TXA and RXA (RS-485 mode)	No shorting (RS-422 mode)	OFF	OFF	ON	ON
8	Switches the shorting of TXB and RXB ON or OFF	Shorts TXB and RXB (RS-485 mode)	No shorting (RS-422 mode)	OFF	OFF	ON	ON
9	RTS Automatic control mode ^{*1} (enabled only when RS-485 mode)	The data is automatically controlled via the RTS signal.	The data is not automatically controlled via the RTS signal.	OFF	OFF	OFF	ON
10				OFF	OFF	OFF	ON

Table 2) Serial Mode Select SW

*1 This setting determines whether or not the TXD output driver is automatically controlled via the RTS signal.

*2 If you use the termination resistance, base your settings on the connection specifications.

Serial Mode Select SW (SW4 to SW10) operate as shown in the circuit diagram below.

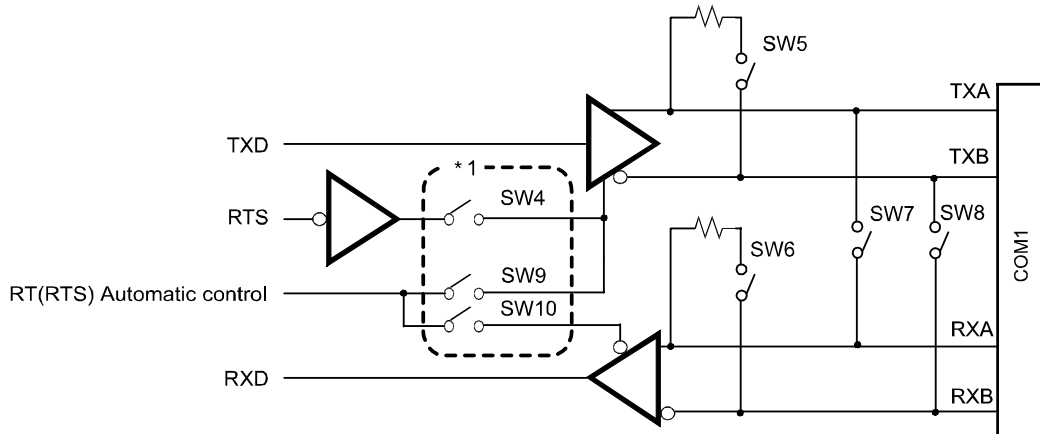

*1 To enable RTS automatic control of the TX output driver, be sure to set SW No. 9 and 10 ON, and set SW No.4 OFF.

To enable control of the TX output driver via RTS signals, be sure to set SW No. 9 and 10 OFF, and set SW No.4 ON.

■ System Set SW 2

Switch No.	Description	ON	OFF	Notes
1	Changeover of Master / Slave setting for primary CF Card I/F	Master	Slave	Factory Settings: ON
2	Used for the system.	Reserved	Reserved	Factory Settings: OFF
3	RAS Input Start Setting ^{*1}	Enabled	Disabled	Factory Settings: OFF
4	Used for the system.	Reserved	Reserved	Factory Settings: OFF

Table 3) System Set SW 2

*1 See “■ RAS Input Start (page2-12)” for RAS Input Start details. This feature is only available for RAS port type.

2.5 Dimensions

The following dimensions apply to PS-3650A/PS-3651A Series units.
(This figure shows an AC Power Supply Type. DC Power Supply Type has same dimensions.)

2.5.1 PS-3650A Series External Dimensions

Unit: mm [in.]

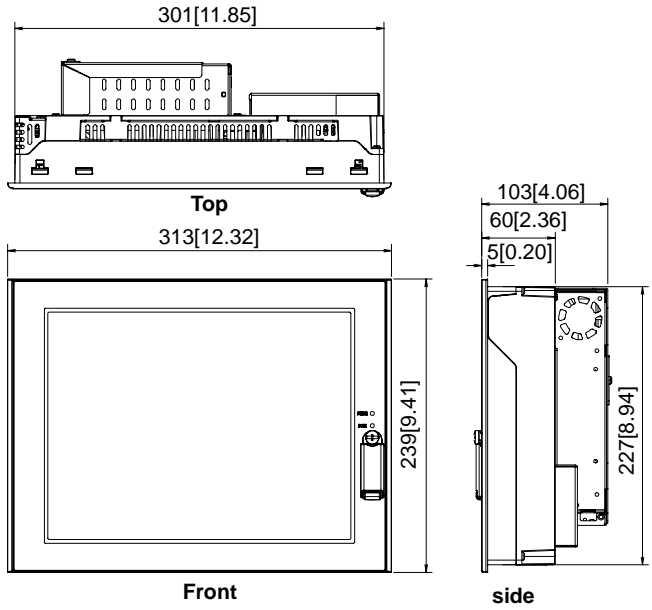

■ Dimensions with installation fasteners

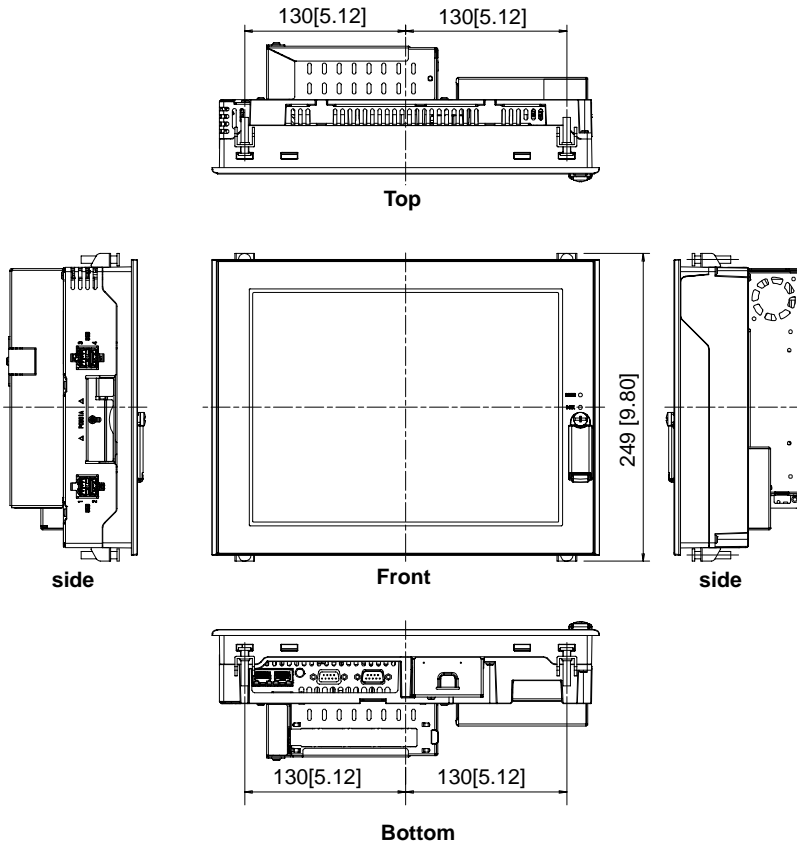

2.5.2 PS-3651A Series External Dimensions

Unit: mm [in.]

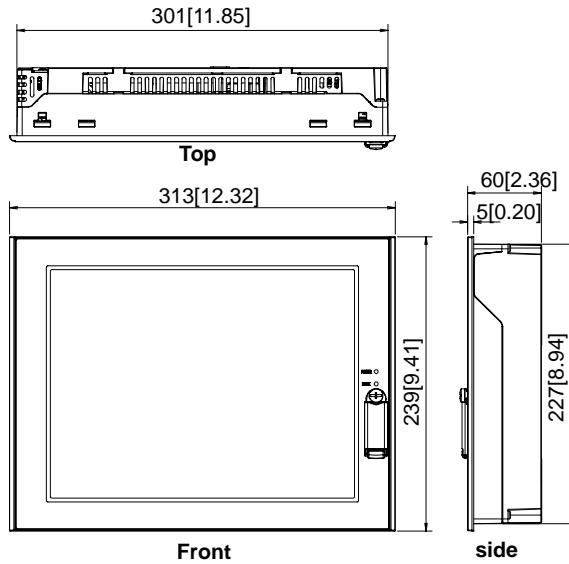

■ Dimensions with installation fasteners

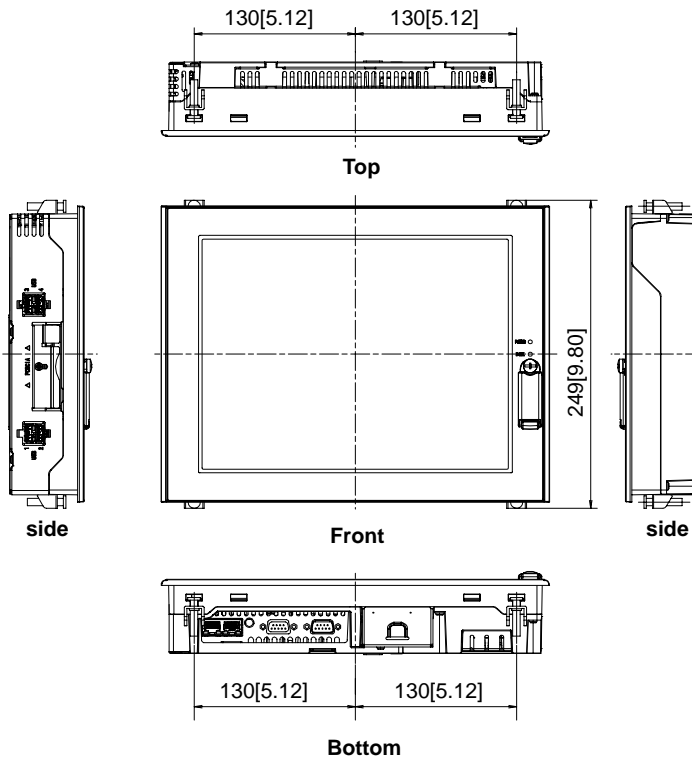

2.5.3 Panel Cut Dimensions

Panel cut dimensions for both PS-3650A Series and PS-3651A Series are the same.

Unit: mm [in.]

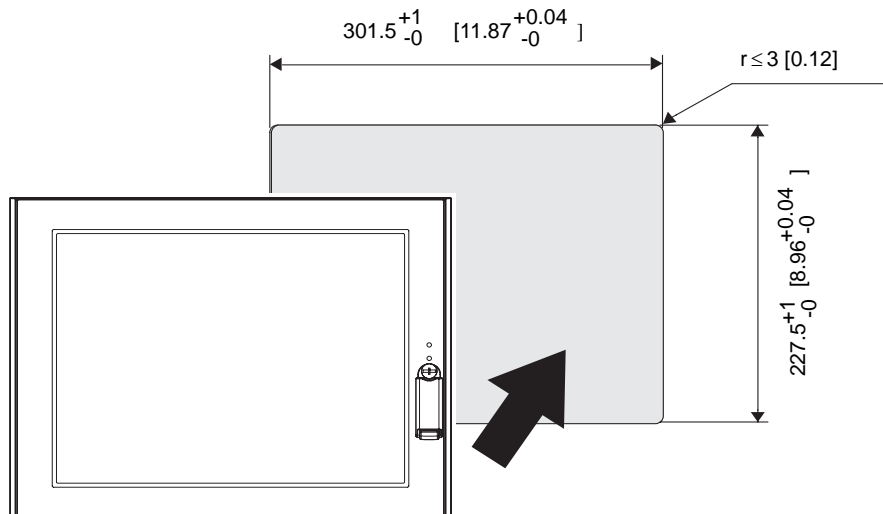

NOTE

- Please read “3.1.1 Installation Procedures (page 3-2)” before designing the Panel Cut.

2.5.4 Installation Fasteners

Unit: mm [in.]

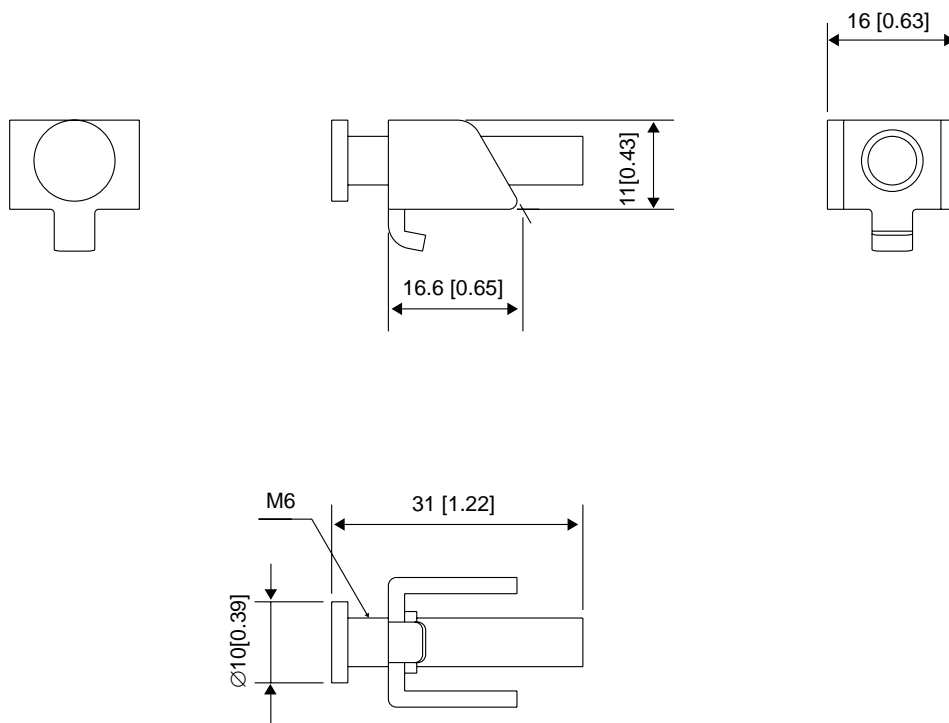

3

Installation and Wiring

1. Installation
2. Peripheral Devices Installation
3. Wiring Precautions

3.1 Installation

3.1.1 Installation Procedures

This section describes the procedures and precautions for installing the PS-A unit.

Follow the steps given below when installing the PS-A unit.

■ Check the Installation Gasket's Seating

It is strongly recommended that you use the installation gasket, since it absorbs vibration in addition to repelling water.

For the procedure for attaching the installation gasket, refer to the following.

SEE → 4.4 Replacing the Installation Gasket (page4-6)

IMPORTANT

- Before installing the PS-A unit into a cabinet or panel, check that the installation gasket is securely attached to the unit.
- A gasket which has been used for a long period of time may have scratches or dirt on it, and could have lost much of its dust and drip resistance. Be sure to change the gasket periodically (or when scratches or dirt become visible).

■ Creating a Panel Cut

Create the correct sized opening required to install the PS-A unit, using the installation dimensions given.

The installation gasket and the installation fasteners are required when installing the PS-A unit.

SEE → 2.5.3 Panel Cut Dimensions (page2-23)

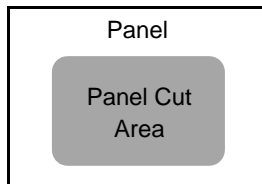

NOTE

- Check that the installation panel or cabinet's surface is flat, in good condition and has no jagged edges.
- Even if panel thickness is within recommend range for "Panel Cut Dimensions", the panel could warp, depending on panel's material and installation location of PS-A or other devices. To prevent panel warpage, the installation surface may need to be strengthened.

IMPORTANT

- Panel thickness should be from 1.6mm [0.06 in.] to 10.0mm [0.39 in.]. Decide the panel's thickness based on the level of panel strength required.

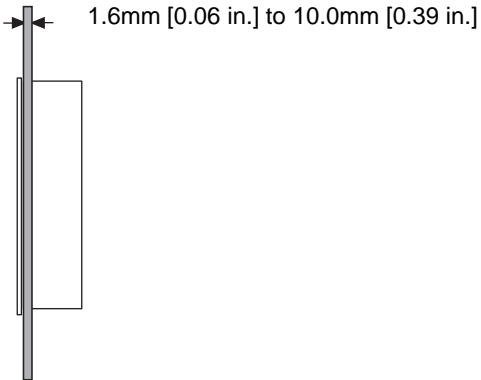

- For easier maintenance, operation, and improved ventilation, be sure to install the PS-A unit at least 50 mm [1.97 in.] away from adjacent structures and other equipment.

Unit: mm [in.]

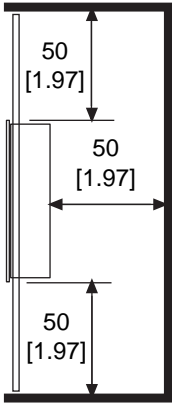
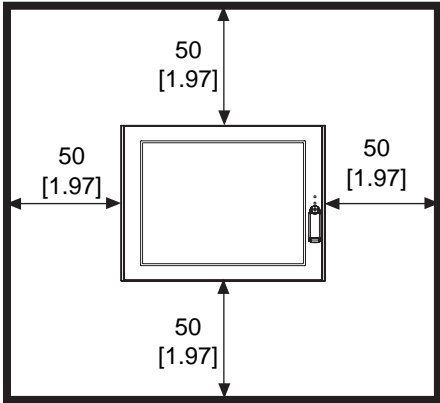

IMPORTANT

- Be sure that the ambient operation temperature and the ambient humidity are within their designated ranges. When installing the PS-A unit on the panel of a cabinet or enclosure, "Ambient operation temperature" indicates both the panel face and cabinet or enclosure's internal temperature.

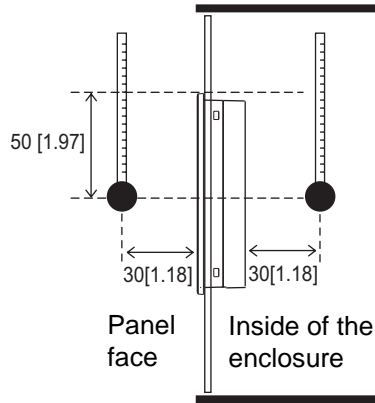

- Be sure that heat from surrounding equipment does not cause the PS-A unit to exceed its standard operating temperature.
- When installing the PS-A unit in a slanted panel, the panel face should not incline more than 30°.

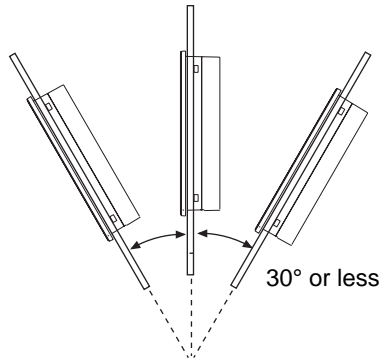

- When installing the PS-A unit in a slanted panel, and the panel face inclines more than 30°, the ambient temperature must not exceed 40°C. You may need to use forced air cooling (fan, A/C) to ensure the ambient operating temperature is 40°C or below.
- The PS-A unit does not support longitudinal mounting.

■ Installing the PS-A unit

- (1) Insert the PS-A unit into the panel cut, as shown.

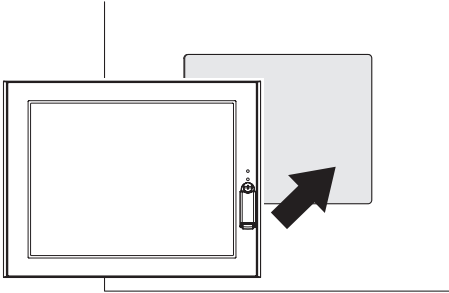

- (2) Insert the installation fasteners into the PS-A unit insertion slots, at the top and bottom of the unit. (total: 4 slots)

IMPORTANT

- Insert each installation fastener securely into the slot's recess (shaded area).

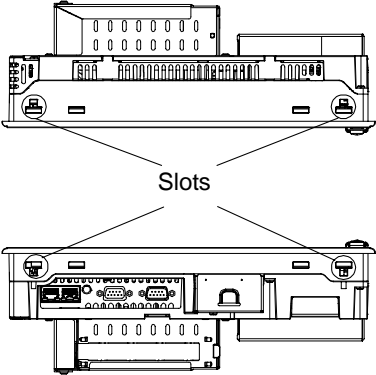
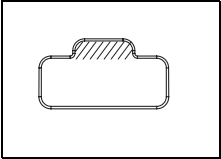

- (3) Insert each of the fasteners shown below. Be sure to pull the fastener back until it is flush with the rear of the attachment hole.

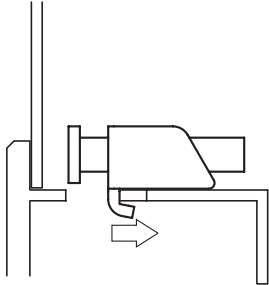
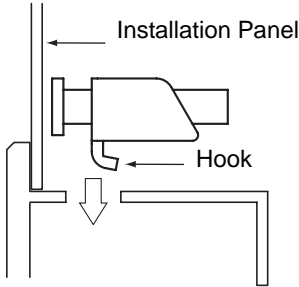

- (4) Use a Phillips screwdriver to tighten each fastener screw and secure the PS-A unit in place.

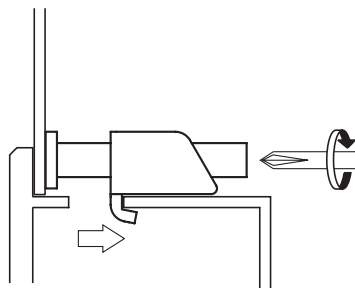

IMPORTANT

- Tightening the screws with too much force can damage the PS-A unit's plastic case.
- For the gasket's moisture resistance to be effective, the torque required to tighten these screws is 0.5 N•m.

3.2 Peripheral Devices Installation

A wide variety of optional units, DIM module, CF Cards, manufactured by Pro-face and commercial Expansion boards (PCI bus compatible board), PCMCIA (PC Cards) can be used with the PS-A unit. (Expansion boards are used only for PS-3650A Series.)

When installing the optional units, refer to each unit's "Installation Guide".

⚠ WARNING

- ⊘ Be sure to confirm that power is not supplied to the PS-A unit before installing or removing any optional units, DIM module, CF Cards, Expansion boards (PCI boards), or PCMCIA (PC Cards). Failure to do so can result in an electric shock.

IMPORTANT

- If the PS-A unit is in the Soft OFF Status, power is supplied to a part of circuits even when no screen is displayed. Be sure to confirm that a power cable is not connected before installing or removing peripheral equipment.
- Use a screwdriver to loosen or tighten the screws. Be sure not to tighten screws too tightly, since it may damage the unit.
- When removing or replacing screws, be careful that they do not fall inside the PS-A unit's chassis.
- When installing the PS-A unit, or when attaching an optional item to the PS-A unit, do not hold the PS-A unit's rear-face Fan Unit while performing the work. Doing so may damage the fan cover or cause the cover to fall off.

3.2.1 Main Memory Installation

■ PS-3650A Series

- (1) Turn OFF the power switch of the PS-A unit and remove the power cable. Place the PS-A unit on a flat, level surface facing the display face downwards.
- (2) Unscrew the screws (2) as you see on the following figure, and remove the Fan Unit.

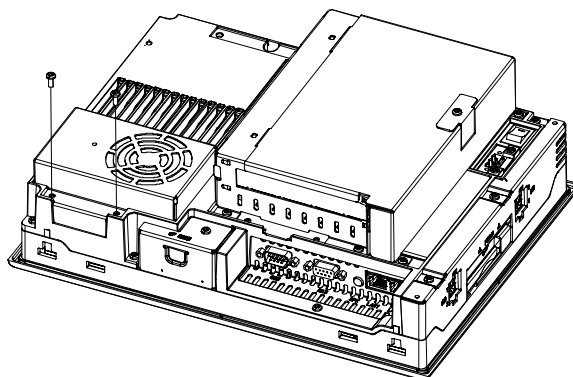

- (3) Install the Main Memory where the following figure shows. Insert the optional DIM module into the connector completely, then gently press it downward until it is locked into the stopper.

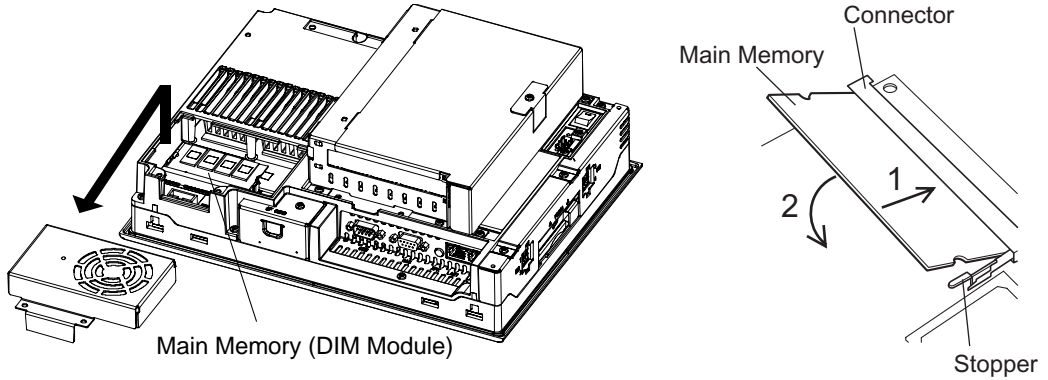

- (4) Reinstall the Fan Unit and attach with two screws. The torque required to tighten these screws is 0.5 to 0.6N•m.

■ PS-3651A Series

- (1) Turn OFF the power switch of the PS-A unit and remove the power cable. Place the PS-A unit on a flat, level surface facing the display face downwards.
- (2) Unscrew the screws (2) as you see on the following figure, and remove the Memory Slot Cover.

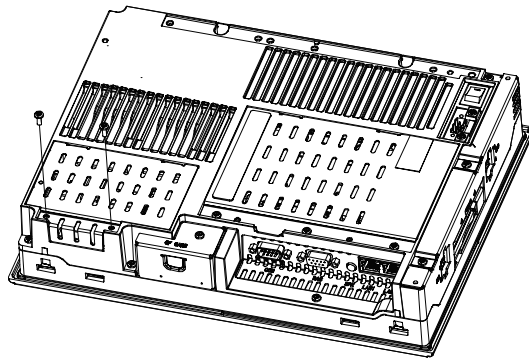

- (3) Install the Main Memory where the following figure shows. Insert the optional DIM module into the connector completely, then gently press it downward until it is locked into the stopper.

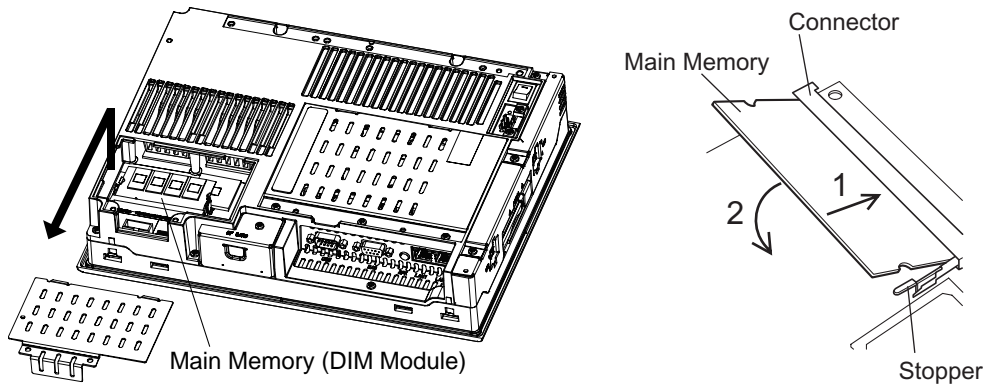

- (4) Reinstall the Memory Slot Cover and attach with two screws. The torque required to tighten these screws is 0.5 to 0.6N•m.

3.2.2 PCI Board Installation

A PCI board, commercially available, can be installed on the PS-3650A Series unit.

NOTE

- The maximum size allowed for a PCI board is 174.63mm [6.88in.] × 106.68mm [4.2in.].

- (1) Turn OFF the power switch of the PS-A unit and remove the power cable. Place the PS-A unit on a flat, level surface facing the display face downwards
- (2) Unscrew a screw of the Expansion Board Support and remove the Expansion Board Support.

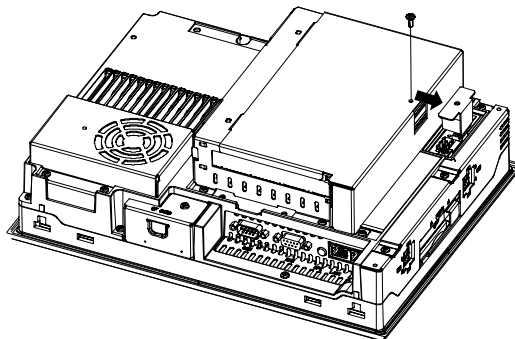

- (3) Unscrew the Expansion Board Cover's screws (2) and remove the Expansion Board Cover.

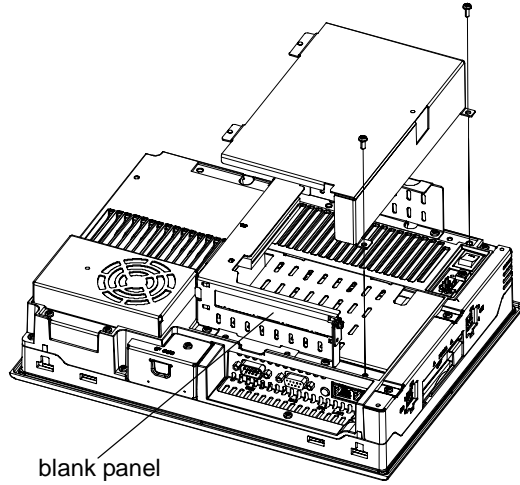

- (4) Unscrew the blank panel screw and take out the blank panel.
- (5) Insert the PCI board into the Expansion Board connector and replace the blank panel screw to attach the PCI board. The torque required to tighten a screw is 0.5 to 0.6N•m.

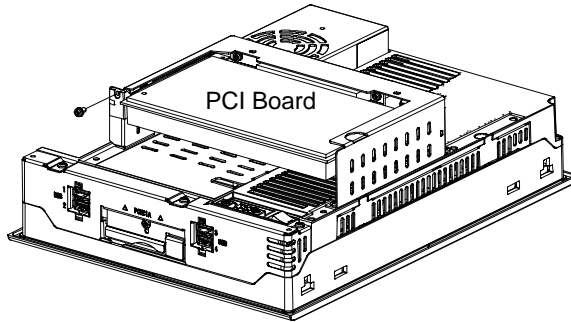

- (6) Reinstall the Expansion Board Cover and Expansion Board Support. The torque required to tighten each of the screws is 0.5 to 0.6N•m.

3.2.3 PCMCIA (PC Card) Installation/Removal

- (1) Loosen a screw in the PCMCIA slot on the side of the PS-A unit and slide the cover in the direction of the arrow as shown below.

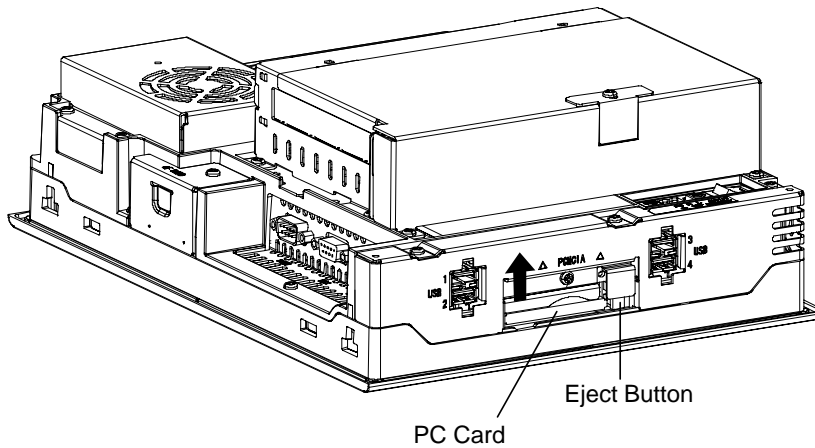

- (2) Press the eject button twice to remove the PC Card from the PCMCIA connector. (Pressing the eject button once causes the tip to come out. Pressing the eject button the second ejects the PC Card from the PCMCIA slot.)
- (3) Reinstall the PCMCIA slot cover and tighten a screw. The torque required to tighten these screws is 0.5 to 0.6N•m.

IMPORTANT

- When using a PC Card with a cable attached, Pro-face recommends you use a clamp or other type of device to prevent vibration from possibly dislodging the cable.
- When powering ON the PS-A unit, be sure to stop the PS-A unit's PC Card driver prior to removing the PC Card. Failure to stop this driver may result in damage to either the PC Card, the PC Card's data, or may cause Windows[®] to stop. For information on the procedure for stopping the PC Card's driver, please refer to your OS' User Manual.







NOTE

- With the display face of PS-A unit downward (as illustrated), insert the PC Card face up.

3.2.4 CF Card Insertion/Removal

When using the PS-A unit and a CF Card, observe the following precautions:

CAUTION

-  Prior to inserting or removing a CF Card, be sure to confirm that the PS-A unit is turned OFF. If you do not, CF Card internal data may be damaged or lost or the OS may stop.
-  While a CF Card is being accessed (HDD/IDE Access lamp: Lit in green), NEVER turn OFF or reset the PS-A unit, or insert or remove the CF Card. If you do not, CF Card internal data may be damaged or lost.
-  Prior to inserting a CF Card, familiarize yourself with the CF Card's front and rear face orientation, as well as the CF Card connector's position. If the CF Card is not correctly positioned and inserted into the PS-A's CF Card Interface, the CF Card, it's internal data, and the PS-A unit may be damaged or broken.
-  Be sure to use only CF Cards manufactured by Pro-face. The CF Card's internal data may be damaged when using another manufacturer's CF Card.
-  Once PS-A data is lost, it cannot be recovered. Since accidental data loss can occur at any time, be sure to back up all PS-A unit screen and CF Card data regularly.
-  Be sure to follow the instructions given below to prevent the CF Card's internal data from being destroyed or a CF Card malfunction from occurring:
 - DO NOT bend the CF Card.
 - DO NOT drop or strike the CF Card against another object.
 - Keep the CF Card dry.
 - DO NOT touch the CF Card connectors.
 - DO NOT disassemble or modify the CF Card.

■ Inserting the CF Card

Use the following steps to insert the CF Card in the PS-A unit.

- (1) Confirm that the PS-A unit is turned OFF.
- (2) Loosen a screw of the CF Card cover and remove the CF Card cover.

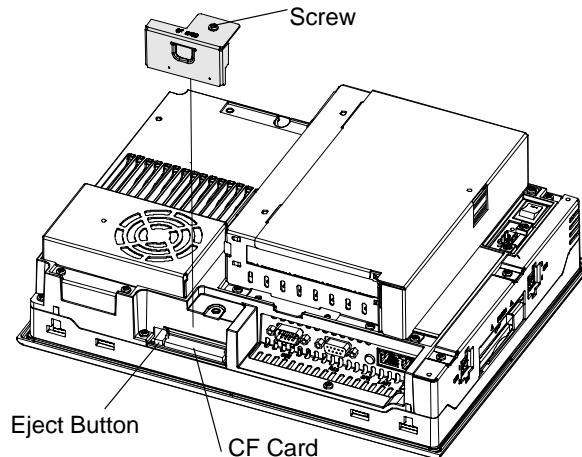

- (3) Confirm the front and back of the CF Card and insert the CF Card in the CF Card slot. Push the eject button completely until the eject button is pushed forward.
- (4) Install the CF Card cover and attach it with a screw.

NOTE

- Make sure that the CF Card cover is closed when accessing the CF Card.
- The torque required to tighten a screw is 0.5 to 0.6N•m.

■ Removing the CF Card

Confirm that the PS-A unit is turned OFF. Remove the CF Card cover, press the eject button and carefully remove the CF Card. After removing the CF Card, be sure to place back the CF Card cover and attach the cover with a screw.

■ Backup of CF Card

The CF Card has a data overwrite limit of approximately 100,000 times. Therefore, be sure to back up all CF Card data regularly to another storage media. (100,000 times assumes the overwriting of 500KB of data in DOS format.)

< If your PC is equipped with a PC Card Slot >

- (1) Install the CF Card into a CF Card Adapter (GP077-CFAD10) and insert it into a PC Card slot of a personal computer.
- (2) Save the data of the CF Card with your personal computer.

<If your PC is NOT equipped with a PC Card slot>

- (1) Use a commercially available PC Card Reader, or a CF Card Reader.

3.2.5 HDD Unit Installation

⚠ WARNING

! Shock Danger! Be sure to unplug the PS-A unit from its power supply prior to installing the HDD unit.

IMPORTANT

- Since the HDD unit and the PS-A unit's circuit board are precision instruments that have a low resistance to shocks, be sure they are neither hit by nor pressed strongly against another object when installing the HDD.
- Even when the screen display of the monitor connected to the PS-A unit is blank, the power might be distributed internally (for example, in the Standby state). Make sure that the power supply of the PS-A unit is off when installing or removing the HDD unit.

■ PS-3650A Series

- (1) Turn OFF the power switch of the PS-A and remove the power cable. Place the PS-A unit on a flat, level surface facing the display face downwards.
- (2) Unscrew the Expansion Board Cover's screws (2) and remove the Expansion Board Cover.

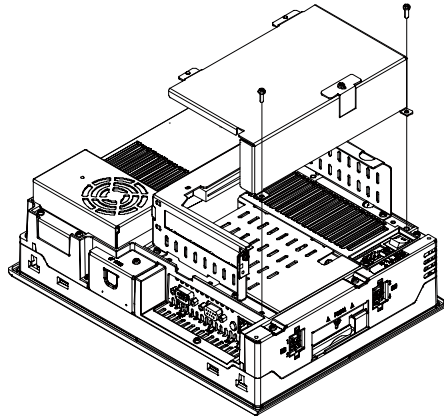

- (3) Unscrew the Expansion Board Base's screws (4) and remove the Expansion Board Base.

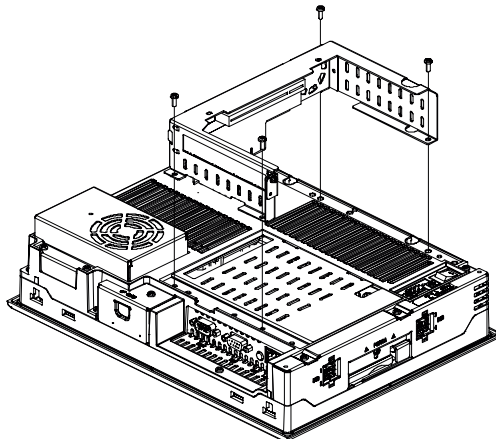

- (4) Remove the DISK cover.

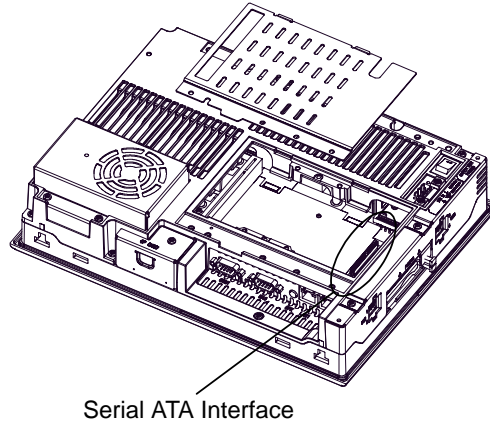

- (5) Mount the HDD unit vertically on the circuit board and plug the HDD unit cable connector in the Serial ATA interface.

IMPORTANT

- Be sure to mount the HDD unit slowly and vertically and not to hit the circuit board with the HDD unit. Contact may cause a malfunction or damage the HDD unit and PS-A unit.

- (6) Attach the HDD unit with the screws (4) which are contained in your package. The torque required to tighten these screws is 0.5 to 0.6 N•m.

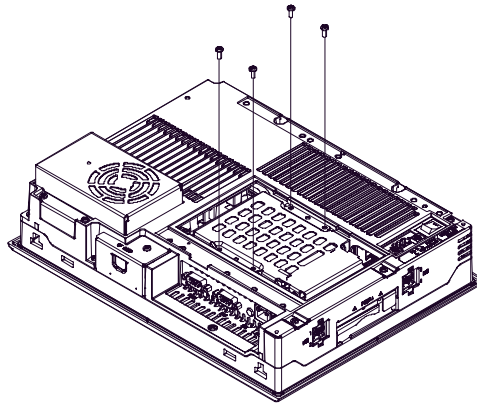

- (7) Reversing the steps above, return the DISK cover, Expansion Board Base, and Expansion Board Cover to the PS-A unit, respectively. The torque required to tighten these screws is 0.5 to 0.6 N•m.

■ PS-3651A Series

- (1) Turn OFF the power switch of the PS-A unit and remove the power cable. Place the PS-A unit on a flat, level surface facing the display face downwards.
- (2) Unscrew the DISK cover's screws (3) and remove the disk cover.

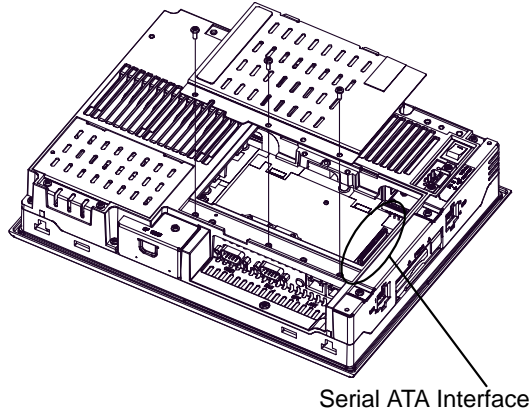

- (3) Mount the HDD unit vertically on the circuit board and plug the HDD unit cable connector in the Serial ATA interface.

IMPORTANT

- Be sure to mount the HDD unit slowly and vertically and not to hit the circuit board with the HDD unit. Contact may cause a malfunction or damage the HDD unit and PS-A unit.

- (4) Attach the HDD unit with the screws (4) which are contained in your package. The torque required to tighten these screws is 0.5 to 0.6 N•m.

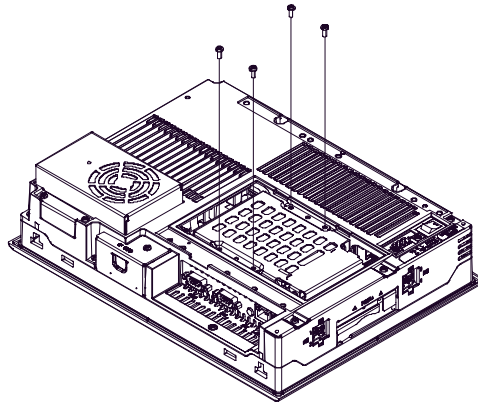

- (5) Reversing the steps above, return the disk cover to the PS-A unit. The torque required to tighten these screws is 0.5 to 0.6 N•m.

3.2.6 USB Holder Attachment/Removal

When using a USB device, attaching the USB holder to the USB Interface located on the side of the PS-A unit prevents the USB cable Interface from becoming disconnected.

■ Attachment

- (1) Attach the USB holder to the USB Interface on the side of the PS-A unit.

Hook the upper pick of the USB holder to the attachment hole of the PS-A unit and then insert the lower pick as shown below to attach the USB holder.

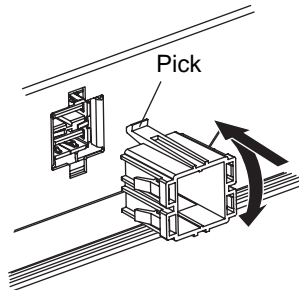

- (2) Insert the USB cable into the USB Interface.

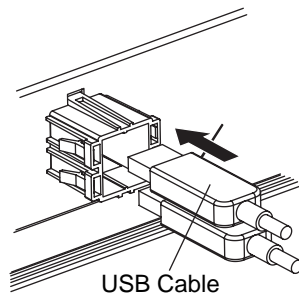

- (3) Insert the USB cover into the tab of the USB holder to attach the USB cable.

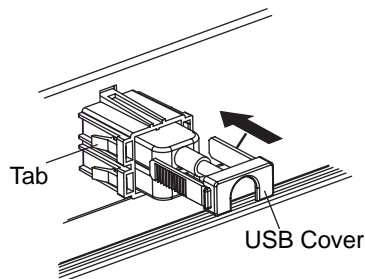

If installing a second USB cable, repeat the steps (2) and (3).

■ Removal

Remove USB Holder by the reverse procedures to the attachment procedures.

- (1) Lift up the tab of the USB holder and then remove the USB cover.

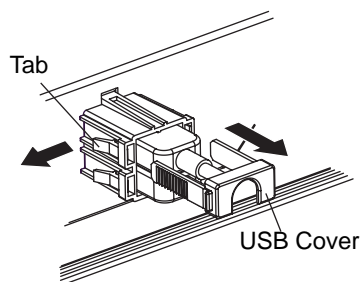





- (2) Remove the USB cable.
- (3) Remove the picks pushing the USB holder from both top and bottom and then remove the USB holder from PS-A unit.

3.3 Wiring Precautions

This section describes the procedures and precautions for wiring power cords.

3.3.1 Connecting the Power Cord

WARNING

-  To avoid an electric shock, prior to connecting the PS-A unit's power cord terminals to the power terminal block, confirm that the PS-A unit's power supply is completely turned OFF, via a breaker, or similar unit.
-  Supplying a power voltage other than that specified will damage the power source and the PS-A unit.
-  Since there is no power switch on the DC Power Supply Type model, be sure to attach a breaker-type switch to the power cord.
-  When the FG terminal is connected, be sure the wire is grounded.

IMPORTANT

- When the FG terminal is connected, be sure the wire is grounded. Not grounding the PS-A unit will result in excess noise and vibration.
- The SG and FG terminals are connected internally in the PS-A unit.
When connecting the SG wire to another device, be sure that the design of the system/connection does not produce a shorting loop.

■ AC Power Supply Type

WARNING

-  The PS-A units is designed to use AC85V to AC265V input. Supplying a power voltage other than that specified will damage the power source and the PS-A unit.

Power Cord Specifications

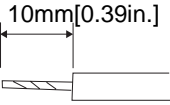
Power Cord Diameter	0.75 to 2.5mm ² (18 to 12 AWG)
Conductor Type	Solid or Stranded Wire *1
Conductor Length	

*1 If the Conductor's end (individual) wires are not twisted correctly, the end wires may either short against each other, or against an electrode.

IMPORTANT

- Use copper conductors only.

Wiring

When connecting the power cord, use the following items when performing wiring. (Items are made by Phoenix Contact. *1)

Recommended Driver	SZS 0.6x3.5 (1205053)
Recommended Pin Terminals	AI 0.75-10GY (3201288) AI 1-10RD (3200182) AI 1.5-10BK (3200195) AI 2.5-12BU (3200962)
Recommended Pin Terminal Crimp Tool	CRIMPFOX ZA3 (1201882)

NOTE

- The Power Supply Connector (plug) is CA7-ACCNL-01 (made by Pro-face) or FKC2.5/3-STF-5.08 (made by Phoenix Contact *1).

*1 For details, please contact your local Phoenix Contact distributor.

Connecting the Power Cord

- (1) Confirm that the power is not supplied to the PS-A unit.
- (2) Unplug the power connector from the rear of the PS-A unit.
- (3) Push the Opening button with a small slot screw driver to open the desired pin hole.

- (4) Insert each pin terminal into its hole. Release the Opening button to clamp the pin place.

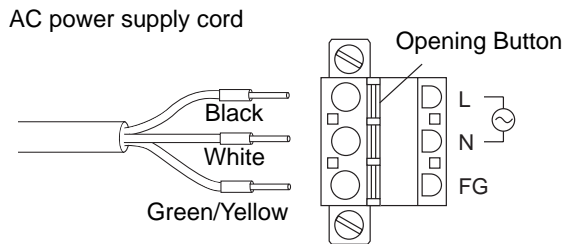

- (5) After inserting all three pins, insert the Power Plug into the PS-A unit's Power Connector. Attach the plug with two (2) slot screws.

IMPORTANT

- Confirm that all wires are connected correctly.
- The torque required to tighten these screws is 0.5 to 0.6N•m.
- To prevent the possibility of a terminal short, use a pin terminal that has an insulating sleeve.

■DC Power Supply Type

Power Cord Specifications

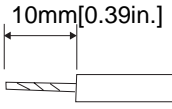
Power Cord Diameter	0.75 to 2.5mm ² (18 to 12 AWG)
Conductor Type	Solid or Stranded Wire ^{*1}
Conductor Length	10mm[0.39in.] 

- *1 If the Conductor's end (individual) wires are not twisted correctly, the end wires may either short against each other, or against an electrode.

IMPORTANT

- Use copper conductors only.

Wiring

When connecting the power cord, use the following items when performing wiring. (Items are made by Phoenix Contact.^{*1)})

Recommended Driver	SZS 0.6x3.5 (1205053)
Recommended Pin Terminals	AI 0.75-10GY (3201288) AI 1-10RD (3200182) AI 1.5-10BK (3200195) AI 2.5-12BU (3200962)
Recommended Pin Terminal Crimp Tool	CRIMPFOX ZA3 (1201882)

NOTE

- The Power Supply Connector (plug) is CA7-DCCNL-01 (made by Pro-face) or GFKC2,5/3-STF-7,62 (made by Phoenix Contact^{*1}).

*1 For details, please contact your local Phoenix Contact distributor.

Connecting the Power Cord

- Confirm that the power is not supplied to the PS-A unit.
- Unplug the power connector from the rear of the PS-A unit.
- Push the Opening button with a small slot screw driver to open the desired pin hole.
- Insert each pin terminal into its hole. Release the Opening button to clamp the pin in place.

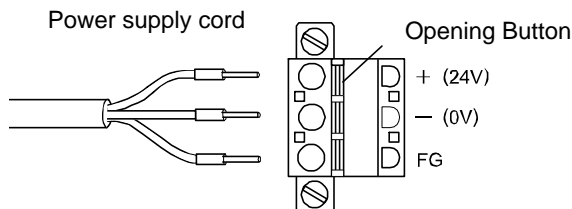

- After inserting all three pins, insert the Power Plug into the Power Connector at PS-A. Attach the plug with two (2) slot screws.

IMPORTANT

- The torque required to tighten these screws is 0.5 to 0.6N•m.
- To prevent the possibility of a terminal short, use a pin terminal that has an insulating sleeve.

3.3.2 Connecting the Power Supply

This section describes the precautions for supplying a power voltage.

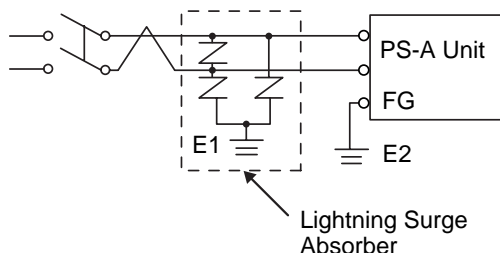
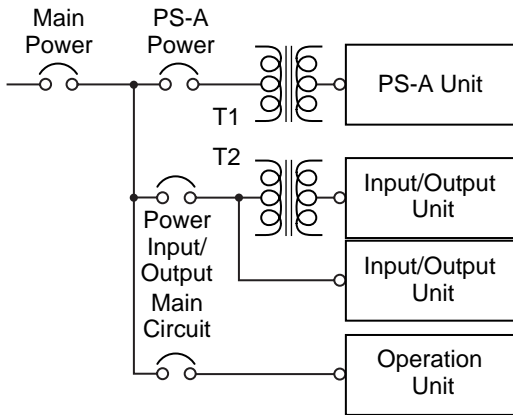
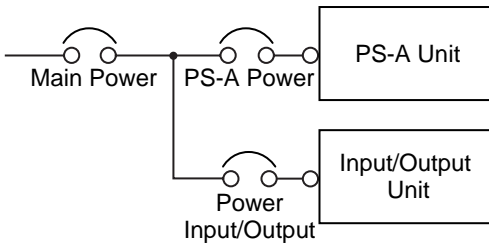
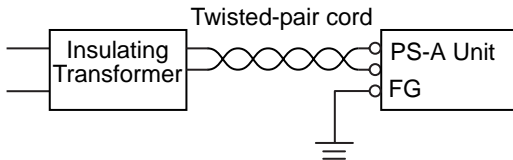
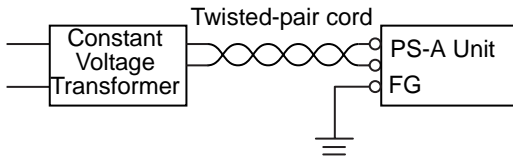

- If the supplied voltage exceeds the PS-A unit's range, connect a constant voltage transformer.

SEE → 2.1.1 Electrical (page2-2)

- Between the line and ground, select a power supply that is low in noise. If there is an excess amount of noise, connect an insulating transformer.

IMPORTANT

- Use constant voltage and insulating transformers with capacities of 200VA or more.
- When supplying power to the PS-A unit, please separate the input/output and power lines, as shown.
- To increase the noise resistance quality of the power cord, it is recommended to attach a ferrite core to the power cord.
- The power supply cable must not be bundled or positioned close to main circuit lines (high voltage, high current), or input/output signal lines.
- Connect a lightning surge absorber, as shown in the diagram, to deal with power surges.
- To avoid excess noise, make the power cord as short as possible.

IMPORTANT

- Be sure to ground the surge absorber (E1) separately from the PS-A unit (E2).
- Select a surge absorber that has a maximum circuit voltage greater than that of the peak voltage of the power supply.

3.3.3 Grounding

This section describes the precautions for grounding the PS-A unit.

⚠ CAUTION

❗ Do not use common grounding, since it can lead to an accident or machine breakdown.

(a) Exclusive Grounding (BEST)

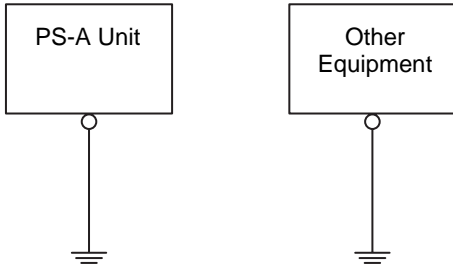

- When supplying power to the PS-A unit, be sure to separate the input/output and power lines, as shown. [diagram (a)]

IMPORTANT

- Check that the grounding resistance is 100Ω or less.
- FG and SG terminals are internally connected in the PS-A unit. When connecting an external device to the PS-A unit using the SG terminal, be sure to check that no short-circuit loop is created when you setup the system.
- The grounding wire should have a cross sectional area of 2mm² or greater. Create the connection point as close to the PS-A unit as possible, and make the wire as short, as possible. When using a long grounding wire, replace the thin wire with a thicker wire, and place it in a duct.

(b) Common Grounding (OK)

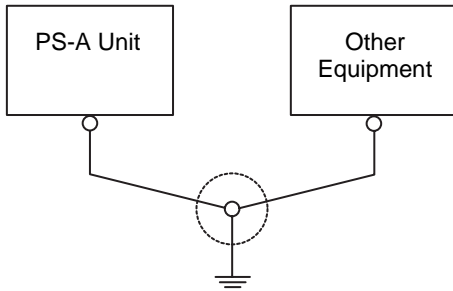

(c) Common Grounding (Not OK)

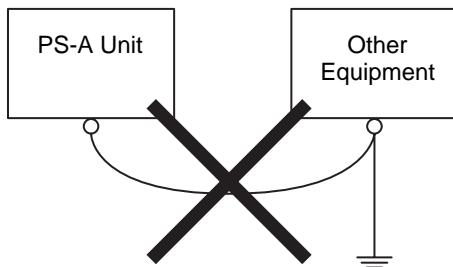

- If exclusive grounding is not possible, use a common connection point. [diagram (b)]

NOTE

- If the equipment does not function properly when grounded, disconnect the ground wire from the FG terminal.

3.3.4 I/O Signal Line Placement

- Input and output signal lines must be separated from the power control cables for operating circuits.
- If this is not possible, use a shielded cable and ground the edge of the shield.

4

Maintenance

1. Cleaning the Display
2. Cleaning the Fan Filter
3. Periodic Check Points
4. Replacing the Installation Gasket
5. Replacing the Backlight
6. Replacing the Internal Battery

This chapter explains cautions and inspection criteria that will ensure trouble-free use of the PS-A unit.

4.1 Cleaning the Display

When the surface or frame of the display becomes dirty, soak a soft cloth in water with a neutral detergent, wring the cloth tightly, and wipe the display surface and frame.

IMPORTANT

- Do not use paint thinner, organic solvents, or a strong acid compound to clean the unit.
- Do not use a hard or pointed object to operate the touch-screen panel, since it can damage the panel surface.

4.2 Cleaning the Fan Filter

In PS-3650A Series, the fan is used for cooling the CPU and the memory. Since excessive dirt and dust in the filter of the fan can potentially affect the performance of the unit, regular cleaning of the filter is strongly recommended.

IMPORTANT

- The PS-A's fan has a lifetime. (Expected life: approx. 5 years at the ambient temperature 25°C)
This lifetime may be shortened depending on the usage environment.
When the fan needs to be replaced, please contact your local PS-A distributor immediately.

- (1) Turn OFF the power switch of the PS-A unit and remove the power cable. Place the PS-A unit on a flat, level surface facing the display face downwards.
- (2) Unscrew the screws (2) (See the figure below) and remove the Fan Unit.

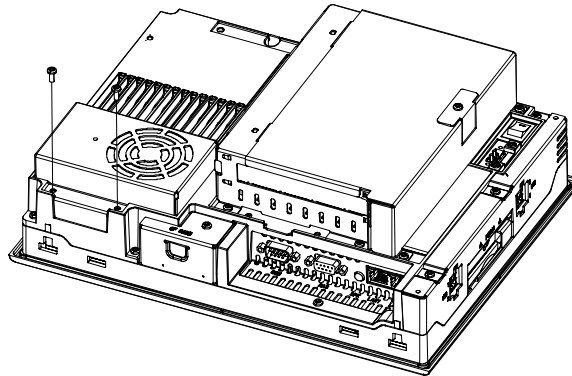

- (3) Turn the Fan Unit upside down. Unscrew the screw (1) and lift the fan. Remove the filter between the fan cover and the fan.

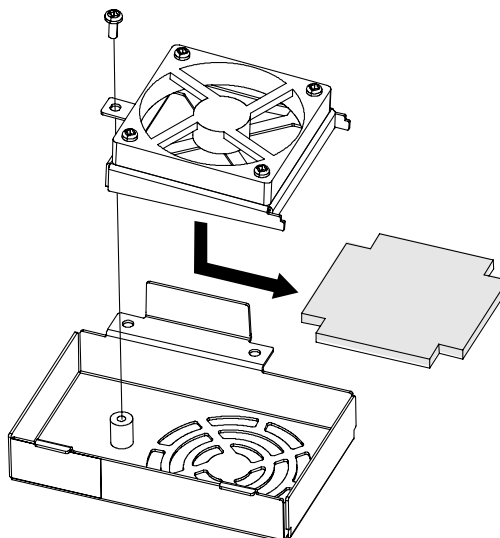

- (4) Remove dust on the filter using a cleaner etc. If stubborn dirt or stains are present, wash the filter with a neutral detergent.

IMPORTANT

- Do not wring the filter to dry it.

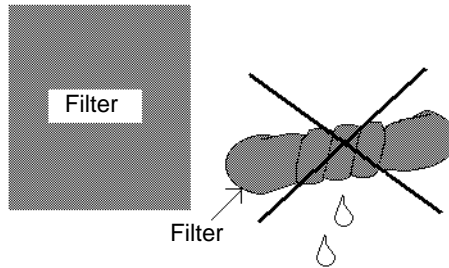

- When drying the filter, dry it without exposing it to direct sunlight.
 - Dry the filter completely before reattaching it.
- (5) Install the filter and tighten the screws of the fan cover.
- (6) Install the Fan Unit in the PS-A unit.

IMPORTANT

- Be sure the fan cover is securely attached to the PS-A unit. This is to ensure the fan cover does not fall while the PS-A unit is operating.
- When installing the Fan Unit in the PS-A unit, be sure to keep the cable on the left side of the back of the PS- A unit so that the fan cannot come into contact with it.

4.3 Periodic Check Points

To keep your PS-A unit in its best condition, please inspect the following points periodically.

■ PS-A Operation Environment

- Is the operating temperature within the allowable range?

(PS-3650A Series)

When using HDD	When not using HDD
5 to 50°C	0 to 50°C

(PS-3651A Series)

When using HDD	When not using HDD
5 to 45°C	0 to 50°C

- Is the operating humidity within the specified range?
10 to 90%RH (Not condensing, wet bulb temperature: 39°C or less, or with HDD 29°C or less.)
- Is the operating atmosphere free of corrosive gasses?
When using the PS-A unit inside a panel, the ambient environment refers to the interior of the panel.

■ Electrical specifications check

- Is the input voltage appropriate?
AC Power Supply Type: AC85 to 265V, 50/60Hz
DC Power Supply Type: DC19.2 to 28.8V

■ Related Items

- Are all power cords and cables connected properly? Have any become loose?
- Are all mounting brackets holding the unit securely?
- Are there many scratches or traces of dirt on the installation gasket?

4.4 Replacing the Installation Gasket

The installation gasket provides protection against dust and moisture.

IMPORTANT

- A gasket which has been used for a long period of time may have scratches or dirt on it, and could have lost much of its water resistance. Be sure to change the gasket at least once a year, or when scratches or dirt become visible.
- The PS-A unit installation gasket's model number is CA3-WPG12-01.

■ Installation Gasket Attachment Procedure

- (1) Place the PS-A unit on a flat, level surface facing the display face downwards.
- (2) Remove the gasket from the PS-A unit.
- (3) Attach the new gasket to the PS-A unit. Be sure to insert the gasket into the PS-A unit's groove so that the gasket's groove sides are vertical.

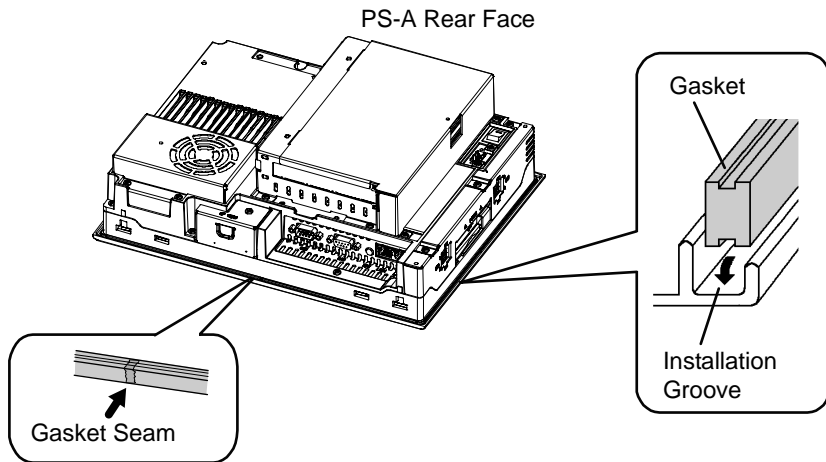

- (4) Check that the gasket is attached correctly to the PS-A unit. The upper surface of the gasket should protrude approximately 2 mm [0.08 in.] out of the groove evenly.

Unit: mm [in.]

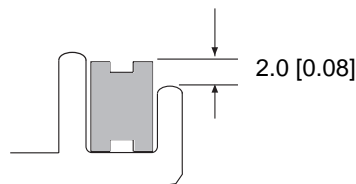

IMPORTANT

- Be sure to confirm the installation condition of the gasket when you install the unit in the panel. The gasket must be inserted correctly into the groove for the PS-A unit's moisture resistance to be equivalent to IP65f.
- Since the gasket is flexible but not elastic, be careful not to stretch it unnecessarily, as doing so could tear the gasket.
- Be sure the gasket's seam is not inserted into any of the unit's corners, only in the straight sections of the groove. Inserting it into a corner may lead to its eventually tearing.
- To ensure stable resistance against dust and moisture, insert the gasket so that the seam is at the bottom of the PS-A unit.

4.5 Replacing the Backlight

PS-A units use a CFL, long-life type backlight. The actual life of the backlight however, will vary depending on the PS-A unit's operating conditions. It is recommended that it be replaced periodically. The service life (half brightness life) of the backlight when it is lit continuously at room temperature is as described below.
60,000 hours - approx. 6.8 years (ambient temperature: 25°C, when lit continuously)

NOTE

- When the LED setting is specified with the RAS control in Control Panel and a backlight burnout is detected, the status LED illuminates in orange.
- If the backlight or the display unit is damaged, the screen display will go out. Even if the screen goes out, however, there is a possibility that the touch panel is still operating correctly. Therefore, since any type of touch panel contact could have an unexpected or dangerous effect or result, be sure not to touch the screen when this condition occurs.
- A backlight burnout is detected by monitoring the consumed current. Depending on the condition of the backlight, a backlight burnout may not be detected or it may be detected before the backlight burns out completely.

⚠ WARNING

⚠ [Electric Shock]

- Whenever changing the backlight, be sure the PS-A unit's power cord has been disconnected and that the unit is cooled down.
- When the PS-A unit's power cord is connected and the PS-A unit is ON, high voltage runs through the wires in the backlight area, do not touch them!

⚠ [Burn]

- The backlight becomes very hot while it is lit. Do not touch the backlight area until the area is cooled down. Be sure to wear gloves to prevent being burned.

⚠ [Glass]

- The backlight is very fragile. Do not touch the glass tube directly or try to remove its power cord, if the glass tube breaks you may be injured.

■ Preparation

Please have the following ready beforehand.

- Replacement backlight (Model:CA8-BLU12XGA-01)
- One pair of clean (preferably new) cotton gloves.
- Phillips screwdriver (no.2)

4.5.1 Backlight Replacement Procedure for PS-3650A Series

Be sure to wear gloves when exchanging the backlight, and follow the following procedures.

- (1) Turn OFF the power switch of the PS-A unit and remove the power cable.
- (2) Remove the PS-A unit from the equipment (panel etc.) to which the unit has been incorporated, and place the PS-A unit on a flat, level surface facing the display face downwards.

IMPORTANT

- Be sure to perform the backlight changeover on a flat, level surface. This will prevent damage to the PS-A unit and the accidental cutting of any of its power cords.
 - Be sure to protect the display surface to prevent damage during the operations.
- (3) Unscrew the screws (2) of the Expansion Board Cover, and remove the Cover.

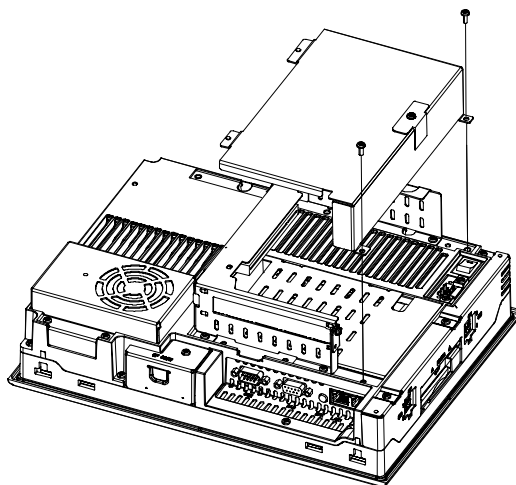

NOTE

- When using the PCI board, it is required to remove the Expansion Board Support first. Then remove the Expansion Board Cover and the PCI board.
- (4) Unscrew the screws (3) of the Mask Cover and remove the cover.

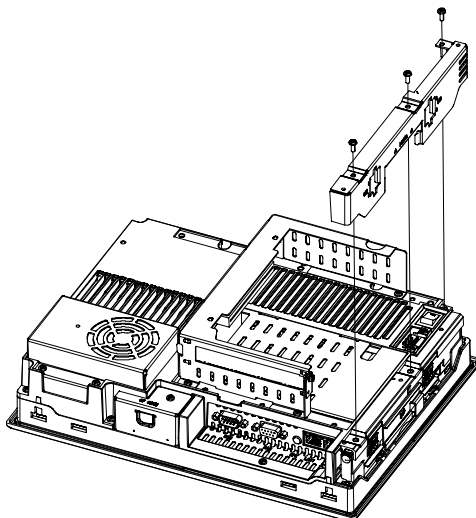

- (5) Unscrew the screws (6) as the figure below indicates.

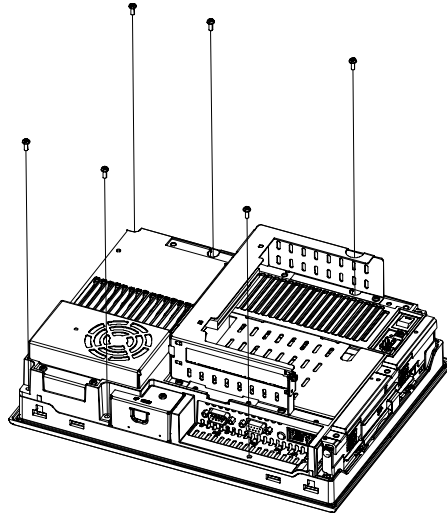

- (6) Open the PS-A unit as the figure below indicates.

Backlight Unit

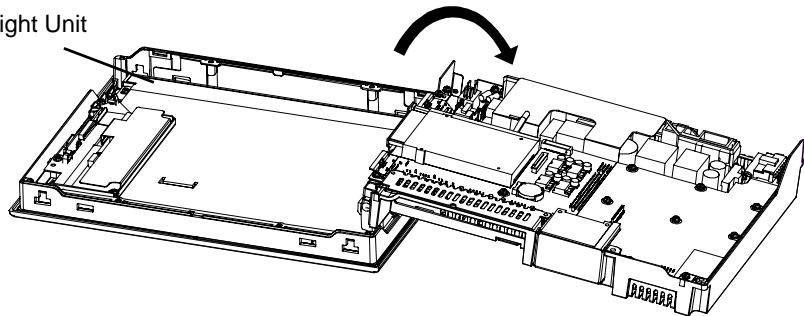

- (7) Disconnect the Backlight Unit cable from the connector on the inverter board. Remove the cable from the cable clamp.

Cable Clamp

Connector

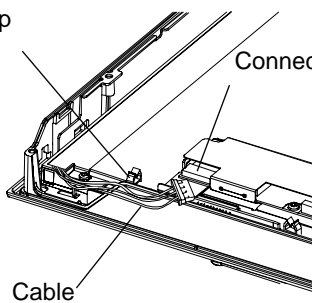

- (8) Loosen the Backlight Unit setscrew (1), lift the edge of the Backlight Unit, and remove the unit by sliding it along the groove.

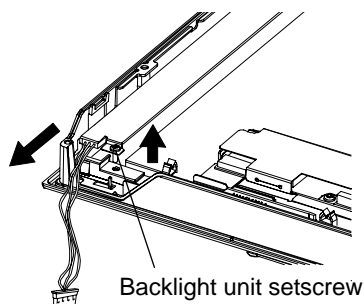

- (9) Insert a new Backlight Unit by sliding it along the groove and fasten the setscrew. The necessary torque is $0.166\text{N}\cdot\text{m}$.

IMPORTANT

- Be sure that no dust or dirt adheres to the backlight surface or to the backlight holder.
- Be sure not to soil the Backlight with moisture, oil content or finger prints; otherwise the life duration of the Backlight will be shortened.

- (10) Insert the Backlight Unit cable to the connector on the inverter board. Secure the cable with the cable clamp.

IMPORTANT

- Be sure to insert the cable into the backlight connector securely. Failure to do so may damage the connector.
- The cable clamp is used to prevent the cable from being caught inside in the PS-A unit and possibly damaged. Be sure to insert the cable into the cable clamp before closing the PS-A unit.

- (11) Return the PS-A unit to the original condition and tighten the screws (6).

IMPORTANT

- If any of the screws is missing, check if it fell inside the PS-A unit's chassis. If the power is turned ON while a screw is inside, it may cause a malfunction.

- (12) Re attach the Mask Cover and then the Expansion Board Cover. The necessary torque is $0.5\text{N}\cdot\text{m}$ to $0.6\text{N}\cdot\text{m}$.

NOTE

- After backlight replacement is completed, turn the PS-A unit's power ON and check if the screens display is normal. If the display is not correct, please contact the Pro-face distributor from whom you purchased the backlight unit.

4.5.2 Backlight Replacement Procedure for PS-3651A Series

Be sure to wear gloves when exchanging the backlight, and follow the following procedures.

- (1) Turn OFF the power switch of the PS-A unit and remove the power cable.
- (2) Remove the PS-A unit from the equipment (panel etc.) to which the unit has been incorporated, and place the PS-A unit on a flat, level surface facing the display face downwards.

IMPORTANT

- Be sure to perform the backlight changeover on a flat, level surface. This will prevent damage to the PS-A unit and the accidental cutting of any of its power cords.
- Be sure to protect the display surface to prevent damage during the operations.

- (3) Unscrew the screws (3) of the Master Cover, and remove the Mask Cover.

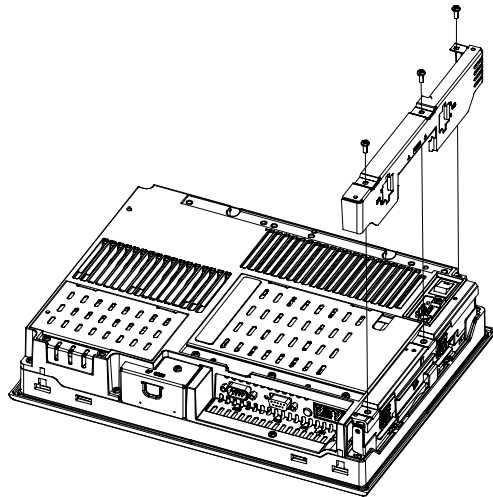

- (4) Unscrew the screws (6) as the figure below indicates.

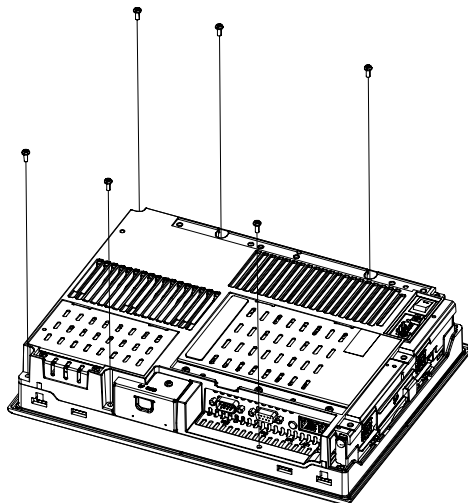

- (5) Open the PS-A unit as the figure below indicates.

Backlight Unit

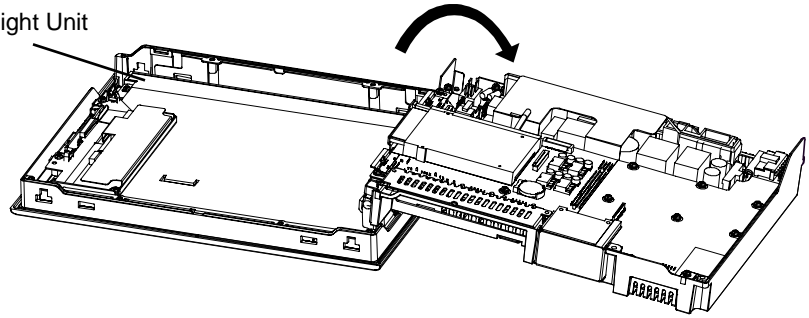

- (6) Disconnect the Backlight Unit cable from the connector on the inverter board. Remove the cable from the cable clamp.

Cable Clamp

Connector

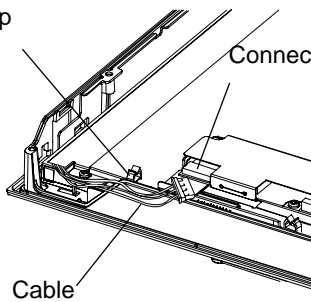

- (7) Loosen the Backlight Unit setscrew (1), and lift the edge of the Backlight Unit. Remove the unit by sliding it along the groove.

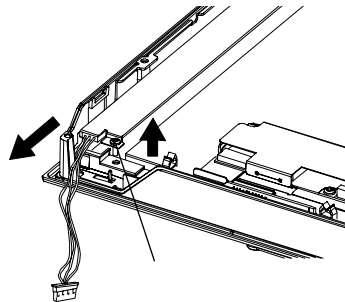

- (8) Insert a new Backlight Unit by sliding it along the groove and fasten the setscrew. The necessary torque is 0.166N•m.

IMPORTANT

- Be careful that no dust or dirt adheres to the backlight surface or to the backlight holder.
- Be careful not to soil the Backlight with moisture, oil content or finger prints; otherwise, the life duration of the Backlight will be shortened.

- (9) Insert the Backlight Unit cable to the connector on the inverter board and secure the cable with the cable clamp.

IMPORTANT

- Be sure to insert the cable into the backlight connector securely. Failure to do so may damage the connector.
- The cable clamp is used to prevent the cable from being caught inside in the PS-A unit and possibly damaged. Be sure to insert the cable into the cable clamp before closing the PS-A unit.

- (10) Return the PS-A unit to the original condition and tighten the screws (6).

IMPORTANT

- If any of the screws is missing, check if it fell inside the PS-A unit's chassis. If the power is turned ON while a screw is inside, it may cause a malfunction.

- (11) Put the Mask Cover back in place and tighten the screws (3).The necessary torque is 0.5N•m to 0.6N•m.

NOTE

- After backlight replacement is completed, turn the PS-A unit's power ON and check if the screen display is normal. If the display is not correct, please contact the Pro-face distributor from whom you purchased the backlight unit.

4.6 Replacing the Internal Battery

The PS-A unit has an internal battery for backup of internal clock data.

Compatible Battery	Service Life
Lithium Battery CR2032 (Hitachi Maxell, Ltd.)	5 years

IMPORTANT

- The expected battery service life is 5 years, however the battery may die before then. It is strongly recommended that you replace the battery regularly.
- When the battery is replaced, the BIOS settings are initialized. Configure the BIOS settings again after replacing the battery.

CAUTION

- ❗ There is a danger of explosion if the PS-A unit's battery is incorrectly replaced. This battery should be replaced with equivalent type recommended by Pro-face.
- ❗ Prior to replacing the battery, be sure to turn OFF the PS-A unit's power.
- ❗ Be careful not to cause a short circuit.
- ⊘ Do NOT touch any internal parts except the battery and the battery holder.
- ❗ During the replacement, be extremely careful not to drop the battery onto the PC board inside the PS-A unit. This may cause product failure.
- ❗ Dispose of used batteries according to the battery manufacturer's instructions.

■ Battery Replacement Procedure

The battery is on the PC board inside the PS-A unit. Refer to “4.5 Replacing the Backlight” for how to open the PS-A unit.

SEE → 4.5.1 Backlight Replacement Procedure for PS-3650A Series (page 4-9)
 4.5.2 Backlight Replacement Procedure for PS-3651A Series (page 4-12)

- (1) Be sure to confirm that power is not supplied to the PS-A unit and open the unit.

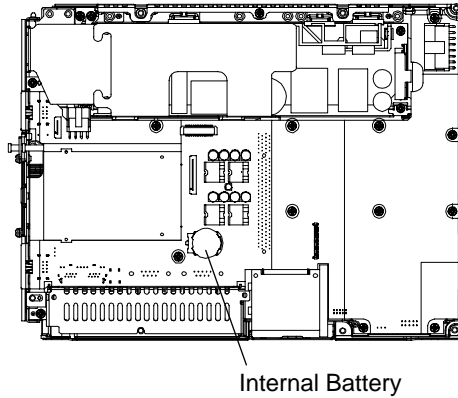

- (2) Remove the battery. Push the clip of the battery holder with your finger, the forceps etc. and the battery is pushed up and removed.

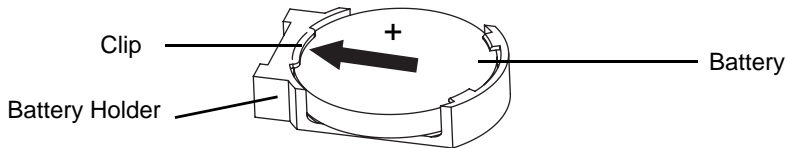

- (3) Insert the new battery. Insert the battery in the side of the clip of the battery holder first with the plus pole (+) facing upward. Push the battery from above until you hear the click to fit it in the battery holder.

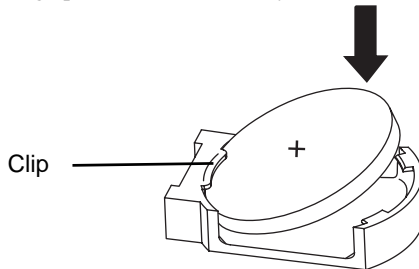

IMPORTANT • Be sure the battery's plus(+) and minus(-) sides are correctly oriented.

- (4) Return the PS-A unit to the original condition.

IMPORTANT • Be sure to adjust the time of the internal clock after replacing the battery.