

PS-3000B Series Hardware Manual



Preface

Thank you for purchasing Pro-face's PS-3000B Series (Hereafter referred to as the "PS-B unit").

Before operating your PS-B unit, be sure to read this manual to familiarize yourself with the PS-B unit's operation procedures and features.

NOTICE

1. Copying this manual's contents, either in whole or in part, is prohibited without the express permission of Digital Electronics Corporation, Japan.
2. The information contained in this manual is subject to change without notice.
3. If you should you find any errors or omissions in this document, please contact Digital Electronics Corporation to report your findings.
4. Regardless of Clause 3 above, Digital Electronics Corporation shall not be held responsible for any damages, losses or third-party damages resulting from the use of this product.

© 2008 Copyright Digital Electronics Corporation. All rights reserved.





Product names used in this manual are the trademarks / registered trademarks of their respective owners.

Essential Safety Precautions

All safety-related procedures stated in this document must be followed to operate the PS-B correctly and safely. Be sure to read this and any related documents thoroughly to understand the correct operation and functions of the PS-B unit.



Safety Icons

Throughout this manual, these icons provide essential safety information for PS-B operation procedures requiring special attention. These icons indicate the following levels of danger:



 WARNING	Indicates situations where severe bodily injury, death or major equipment damage can occur.
 CAUTION	Indicates situations where slight bodily injury or minor equipment damage can occur.
	Indicates actions or procedures that should NOT be performed.
	Indicates actions or procedures that MUST be performed to ensure correct unit operation.

WARNING

System Design

-  Be sure to design your system so that a communication fault between the PS-B and its host controller will not cause equipment to malfunction. This is to prevent any possibility of bodily injury or equipment damage.
-  Do not use the PS-B with aircraft control devices, aerospace equipment, central trunk data transmission (communication) devices, nuclear power control devices, or medical life support equipment, due to these devices' inherent requirements of extremely high levels of safety and reliability.
-  When using the PS-B with transportation vehicles (trains, cars, and ships), disaster and crime prevention devices, various types of safety equipment, and medical devices that are not life-support related, use redundant and/or failsafe system designs to ensure proper reliability and safety.

Handling

-  Do not disassemble or modify the PS-B unit. Doing so may cause a fire or an electric shock.
-  Do not operate the PS-B in an environment where flammable gases are present, since it may cause an explosion.

Wiring

- ⚠ To prevent electrical shock or equipment damage, unplug the PS-B unit's power cord from the power supply prior to installing or wiring the PS-B.
- ⊘ Do not use the voltage not specified in the manual. Doing so may cause a fire or an electric shock.

Maintenance

- ⊘ Do not connect or disconnect Host and PS-B unit communication cables while the PS-B is turned ON.
- ⊘ The PS-B uses a lithium battery for backing up its internal clock data and the battery may explode if it is replaced incorrectly. When replacement is required, use a Pro-face-designated replacement product. SEE "4.3 Replacing the Internal Battery" (page 4-4)

CAUTION

Installation

- ❗ Be sure all cable connectors are securely attached to the PS-B unit. A loose connection may cause incorrect input or output signals.

Wiring

- ❗ Be sure to ground the PS-B unit's FG wire separately from other equipment FG lines. Also, be sure to use a grounding resistance of 100Ω or less and a 2mm² or thicker wire, or your country's applicable standard. Otherwise, electric shock or malfunctions may result.
- ❗ Be sure to use only the designated torque to tighten the PS-B unit's terminal block screws. If these screws are not tightened firmly, it may cause a short-circuit, fire or incorrect unit operation.
- ❗ Be sure that metal particles and wiring debris do not fall inside the PS-B unit. They can cause a fire, malfunction or incorrect unit operation.

Maintenance

- ⊘ Do not reset or turn the PS-B OFF, or insert or remove the CF Card while the PS-B unit's CF Card or hard disk is being accessed. Otherwise, CF Card and the hard disk internal data may be damaged or lost.

Unit Disposal

- ❗ When the product is disposed of, it should be disposed of in a manner appropriate to, and in accordance with, the user country's industrial machinery disposal/recycling standards.



General Safety Precautions

- ⊘ Do not install the PS-B where the ambient temperature exceeds the specified range. Doing so may cause a unit malfunction.
- ⊘ To prevent abnormally high temperatures from occurring inside the PS-B, do not restrict or block the PS-B unit's rear-face ventilation slots.
- ⊘ Do not operate the PS-B in areas where large, sudden temperature changes can occur. These changes can cause condensation to form inside the PS-B, possibly causing it to malfunction.
- ⊘ Do not allow water, liquids or metal fragments to enter inside the PS-B unit's case, since they can cause either a malfunction or an electric shock. The allowable pollution degree is 2.
- ⊘ Do not operate or store the PS-B in locations where it can be exposed to direct sunlight, high temperatures, excessive dust, moisture or vibration.

- ⊘ Do not operate or store the PS-B where chemicals evaporate, or where chemicals are present in the air.
Corrosive chemicals: Acids, alkalines, liquids containing salt
Flammable chemicals: Organic Solvents
- ⊘ Do not use paint thinner or organic solvents to remove dirt or oil from the PS-B unit's surface. Instead, use a soft cloth moistened with a diluted neutral detergent.
- ⚠ After turning OFF the PS-B, be sure to wait a few seconds before turning it ON again. The PS-B may not operate correctly if it is restarted too quickly.
- ⚠ Due to the possibility of unexpected accidents, be sure to back up the PS-B unit's data regularly.

Information Symbols

This manual uses the following icons:

	Indicates a warning or a product limitation. Be sure to follow the instructions given with this icon to ensure the safe operation of the PS-B.
*	Indicates useful or important supplemental information.
	Contains additional or useful information.
	Indicates pages containing related information.

Package Contents

The following items are included in the PS-B unit's package. Before using the PS-B, please check that all items listed here are present.

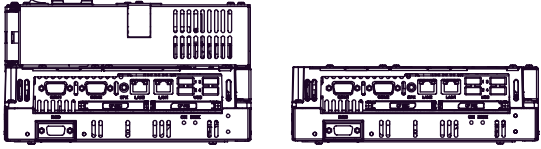
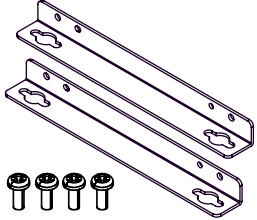
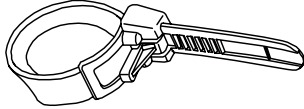
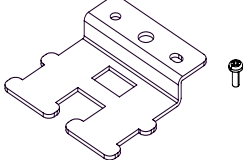
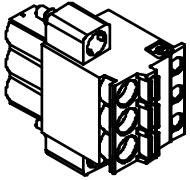
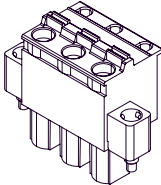
<p>PS-B Unit: 1</p>  <p>PS3000-BA PS3001-BD</p>	<ul style="list-style-type: none"> • Installation Guides (Set of Japanese/ Set of English) • Warning/Caution Information (1) 	<p>Installation Fasteners Set: 1 (Fasteners: 2, Screws:4)</p> 
<p>USB Cable Clamp: (2 ports) 2</p> 	<p>USB Holder: 1 Screw: 1</p> 	
<p>Power Connector: 1 (AC type: Included, DC type: Attached to the PS-B unit)</p> <div style="display: flex; justify-content: space-around; align-items: flex-end;"> <div data-bbox="271 909 511 1151">  <p>(for AC type) (5.08mm [0.2in.] pitch)</p> </div> <div data-bbox="861 896 1108 1145">  <p>(for DC type) (7.62mm [0.3in.] pitch)</p> </div> </div>		

IMPORTANT

- Be careful when installing the PS-B not to damage the built-in HDD.

This unit has been carefully packed, with special attention to quality. However, should you find anything damaged or missing, please contact your local PS-B distributor immediately.

Installation prerequisites for standards

- UL listed products

Industrial Control Equipment	refer to UL508	see [a] in the "Product List"
------------------------------	----------------	-------------------------------

- c-UL listed products

Process Control Equipment	refer to CSA-C22.2 No.142	see [b] in the "Product List"
---------------------------	---------------------------	-------------------------------

- Product List

Product Model No.	Registration Model No.	UL	c-UL
		[a]	[b]
PS3000-BA	3681601-01	✓	✓
PS3001-BD	3681601-12	✓	✓

UL/c-UL File No.: E220851

For the detailed certification's information, refer to the Pro-face Home page.

<Cautions>

Be aware of the following items when building the PS-B into an end-use product:

- The PS-B unit is approved as an open-type unit.
- Install the PS-B unit on a flat surface. The PS-B unit must be mounted according to the installation requirements with the specified distance from adjacent structures and equipment. The temperature must be checked on the final product in which the PS-B is installed.

The safety certificate can be downloaded from Pro-face Home Page.

Home Page URL

<http://www.pro-face.com/>

CE Marking

PS3000-BA units are CE marked products that conform to EMC directives and Low Voltage Directives.

PS3001-BD units are CE marked products that conform to EMC directives.

For the detailed information on CE Marked, be downloaded and refer the Declaration of Conformity from Pro-face Home Page.

Home Page URL

<http://www.pro-face.com/>

FCC Statement

United States FCC Part 15, Subpart B, Class A EMI Compliance Statement:

NOTE: This equipment has been tested and found to comply with the limits for a Class A digital device, pursuant to part 15 of the FCC Rules. These limits are designed to provide reasonable protection against harmful interference when the equipment is operated in a commercial environment. This equipment generates, uses, and can radiate radio frequency energy and, if not installed and used in accordance with the instruction manual, may cause harmful interference to radio communications. Operation of this equipment in a residential area is likely to cause harmful interference in which case the user will be required to correct the interference at his or her own expense.

Contents

Preface	1
Essential Safety Precautions.....	2
Information Symbols.....	6
Package Contents	7
Installation prerequisites for standards.....	8
CE Marking.....	8
FCC Statement.....	9
Contents	11

Chapter 1 Overview

1.1 System Design.....	1-2
1.1.1 PS3000-BA	1-2
1.1.2 PS3001-BD	1-3
1.2 Accessories	1-4
1.2.1 Option Items	1-4
1.2.2 Maintenance Items	1-4
1.3 Part Names and Functions	1-5
1.3.1 PS3000-BA	1-5
1.3.2 PS3001-BD	1-7
1.4 Prior to Operating the PS-B Unit.....	1-9
1.4.1 Power Supply.....	1-9

Chapter 2 Specifications

2.1 PS3000-BA	2-2
2.1.1 General Specifications	2-2
2.1.2 Performance Specifications	2-5
2.1.3 Interface Specifications	2-7
2.1.4 Dimensions	2-16
2.2 PS3001-BD	2-19
2.2.1 General Specifications	2-19
2.2.2 Performance Specifications	2-21
2.2.3 Interface Specifications	2-22
2.2.4 Dimensions	2-30

Chapter 3 Installation and Wiring

3.1 Installation • Uninstallation.....	3-2
3.1.1 Installation.....	3-2

3.2 Peripheral Devices Installation	3-6
3.2.1 Main Memory Installation	3-6
3.2.2 Expansion Board (PCI) Installation	3-7
3.2.3 HDD Unit Installation.....	3-10
3.2.4 CF Card Insertion/Removal	3-12
3.2.5 USB Cable Clamp Attachment/Removal	3-14
3.3 Wiring Precautions.....	3-16
3.3.1 Connecting the Power Cord.....	3-16
3.3.2 Connecting the Power Supply.....	3-20
3.3.3 Grounding	3-21
3.3.4 I/O Signal Line Placement	3-22

Chapter 4 Maintenance

4.1 Cleaning the Fan Filter	4-2
4.2 Periodic Check Points.....	4-3
4.3 Replacing the Internal Battery	4-4

1 | Overview

1. System Design
2. Accessories
3. Part Names and Functions
4. Prior to Operating the PS-B Unit

This chapter describes peripheral devices that can be connected to PS-B Series units along with the name and functions of each part.

1.1 System Design

1.1.1 PS3000-BA

The following diagram illustrates the standard range of items that can be connected to PS3000-BA units.

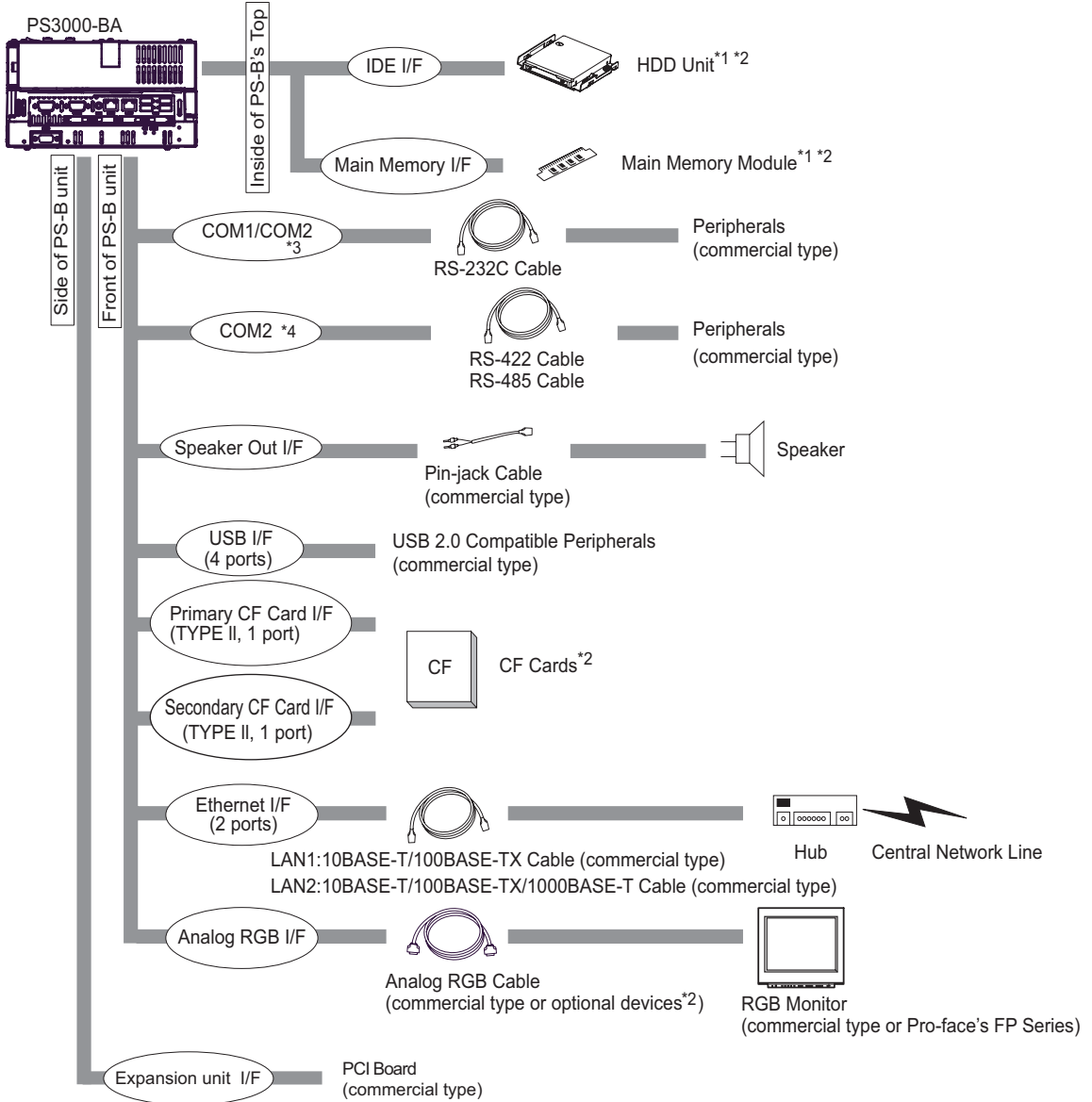

*1 Built-in accessory only

*2 Pro-face's optional devices and commercial products.
Please refer to 1.2 Accessories.

*3 When setting RS-232C mode for COM2.

*4 When setting RS-422 or RS-485 mode for COM2.

1.1.2 PS3001-BD

The following diagram illustrates the standard range of items that can be connected to PS3001-BD units.

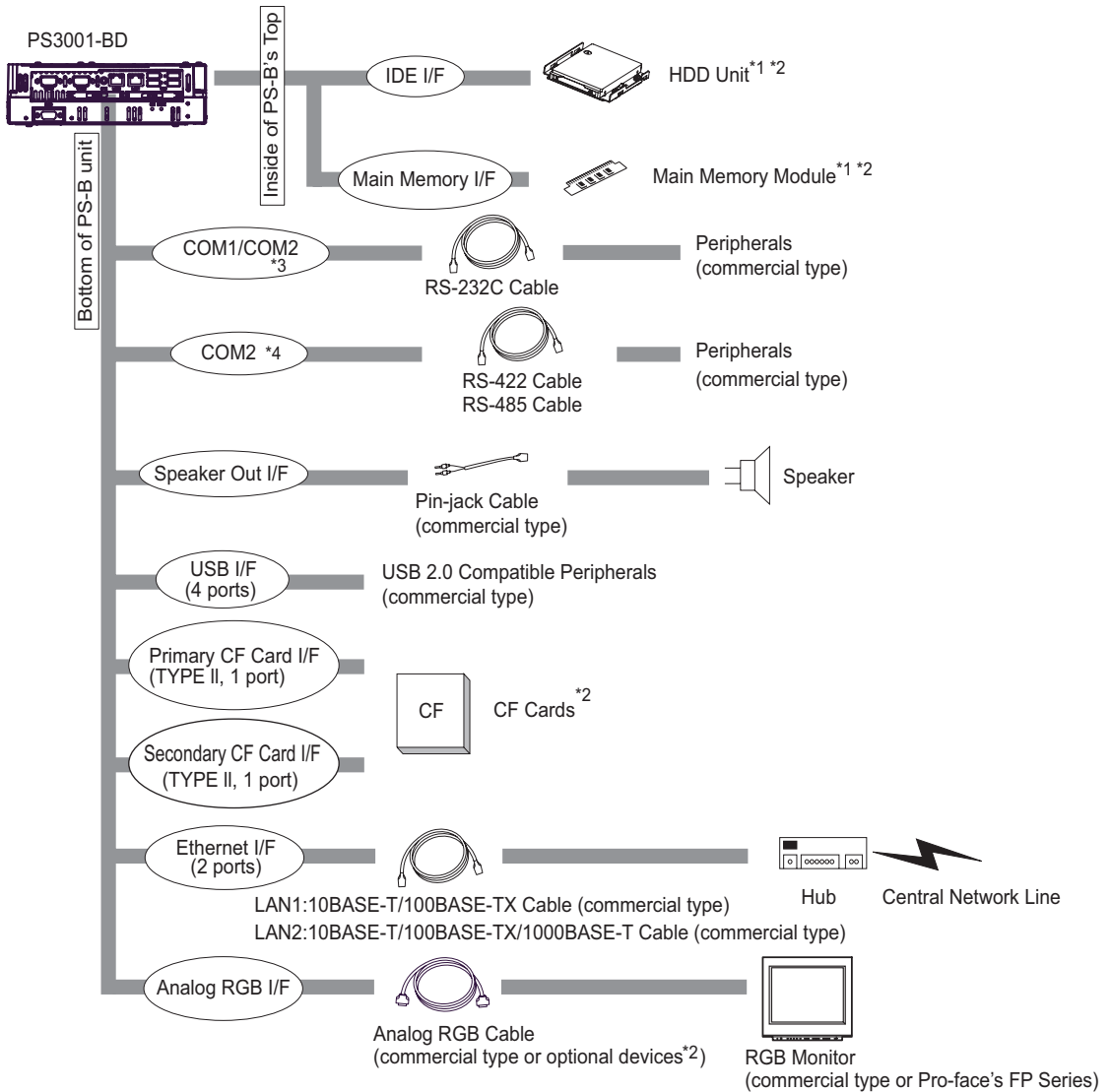

*1 Built-in accessory only

*2 Pro-face's optional devices and commercial products.

Please refer to 1.2 Accessories.

*3 When setting RS-232C mode for COM2.

*4 When setting RS-422 or RS-485 mode for COM2.

1.2 Accessories

All accessories listed here are produced by Digital Electronics Corporation.

1.2.1 Option Items

Product Name	Model No.	Description
DIM module	PSA-DDR512	Memory module 512MB
	PSA-DDR1G	Memory module 1GB
Hard Disk Unit	PS345XA-HD40	HDD Unit mounted is a Type 2.5" PATA Hard Disk (40GB minimum without OS) (only for PS3000-BA)
CF Card	CA3-CFCALL/128MB-0	Type 1 128MB
	CA3-CFCALL/256MB-0	Type 1 256MB
	CA3-CFCALL/512MB-0	Type 1 512MB
	CA6-CFCALL/1GB-01	Type 1 1GB
USB Front Cable	CA5-USBEXT-01 (1m)	Extension cable attaching USB port to the pane
Analog RGB cable	FP-CV02-45	Analog RGB interface cable when image signal is output to the FP Series made by Pro-face from PS-B. (D-sub15 pin, plug) (4.5m)

1.2.2 Maintenance Items

Product Name	Model No.	Description
Installation Fastener	PS3000-ATFB-01	Used to install the PS-B unit. (Fasteners: 2, Screws: 4)
DC Power Supply Connector (Straight)	CA7-DCCNL-01	DC Power Supply Connector (5 connectors/set)
AC Power Supply Connector (Straight)	CA7-ACCNL-01	AC Power Supply Connector (5 connectors/set)

1.3 Part Names and Functions

1.3.1 PS3000-BA

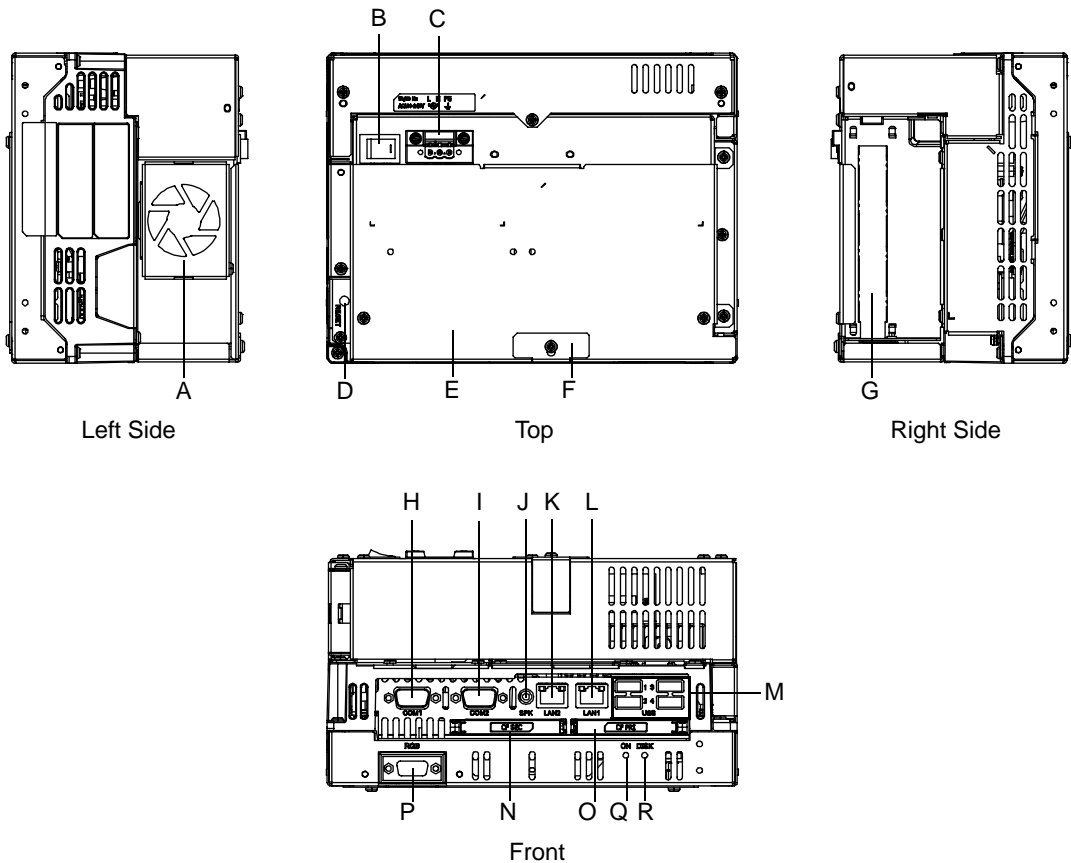

A: Cooling FAN

B: Power Switch

C: Power Connector

D: Reset Switch (RESET)

Used to restart PS-B / turn on the power. Used in combination with System Set SW. Please refer to “◆ Switches (page 2-10)” for details.

E: Expansion Board Cover

F: Expansion Board Support

G: Expansion Unit Interface

1 port. Used to attach the PCI Unit.

H: Serial Interface (COM1)

D-sub 9-pin plug type. RS-232C.

I: Serial Interface (COM2)

D-sub 9-pin plug type. RS-232C, RS-422, RS-485 Changeover. RI/+5V Changeover.

J: Speaker Output Interface (SPK)

1 port. (Mini pin jack connector)

K: Ethernet Interface (LAN2)

10BASE-T/100BASE-TX/1000BASE-T Auto Changeover and Wake On LAN feature. This interface uses an RJ-45 type modular jack connector (8 pins).

L: Ethernet Interface (LAN1)

10BASE-T/100BASE-TX Auto Changeover. This interface uses an RJ-45 type modular jack connector (8 pins).

M: USB Interface (USB)

4 ports. USB 2.0. compatible. Uses a "TYPE-A" connector.

Power supply voltage	5 VDC ±5%
Output current	Each port: 500mA (max.), 4 ports total: 500mA (max.)
Maximum communication distance	5m

N: Secondary CF Card Interface

Open the cover and insert the CF Card. CF Card (Type I/II-compliant) is available. IDE-type connection.*1

O: Primary CF Card Interface

Open the cover and insert the CF Card. CF Card (Type I/II-compliant) is available. IDE-type connection.*1

P: Analog RGB Interface

A mini D-sub 15 pin (socket) is used to connect a RGB monitor on the market or FP Series unit manufactured by Pro-face.

Q: Power LED / RAS Status Lamp (ON)

LED	PS-B Status
Green (lit)	Normal Operation (power is on)
Green (blinking)	Soft OFF state
Orange (lit)	System Monitor Error RAS Error
Not lit	Power is OFF

R: HDD / IDE Access Lamp (DISK)

LED	PS-B Status
Green (lit)	Access to HDD or IDE.
Not lit	Not access to HDD or IDE.

IMPORTANT

- When attaching peripheral units to the PS-B, be sure the PS-B's power cord is disconnected from the main power supply.

*1 Since an IDE-type connection is used, the unit is not hot-swappable. When inserting/removing the CF Card, be sure that power is turned OFF.

1.3.2 PS3001-BD

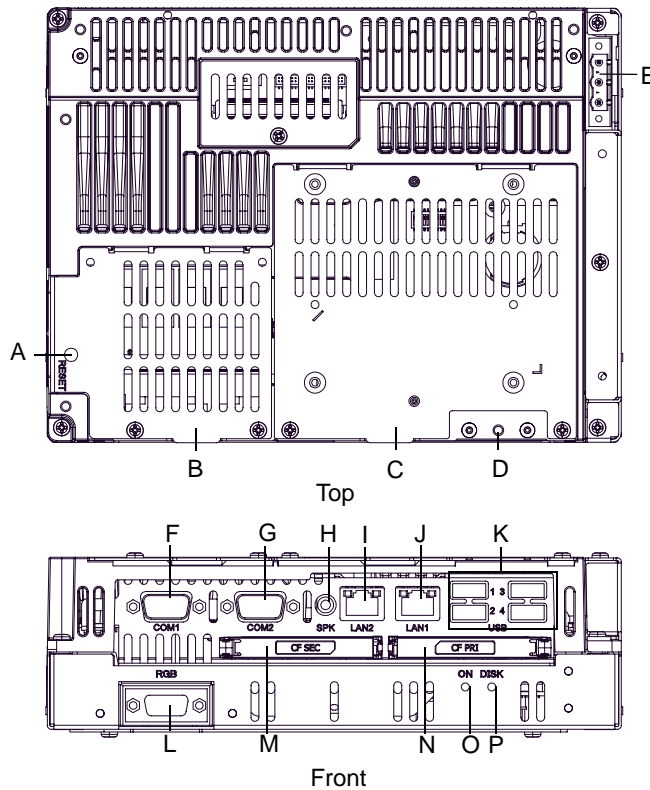
**A: Reset Switch (RESET)**

Used to restart PS-B / turn on the power. Used in combination with System Set SW. Please refer to “◆ Switches (page 2-25)” for details.

B: Memory Slot Cover**C: Maintenance Cover**

When removing this cover, you can set the switches on the PS-B’s circuit board.

D: USB Holder Attachment Area**E: Power Connector****F: Serial Interface (COM1)**

RS-232C. D-sub 9-pin plug type.

G: Serial Interface (COM2)

RS-232C/RS-422/RS-485 Changeover, RI/+5V Changeover. D-sub 9-pin plug type.

H: Speaker Output Interface (SPK)

1 port. (Mini pin jack connector)

I: Ethernet Interface (LAN2)

10BASE-T/100BASE-TX/1000BASE-T Auto Changeover and Wake On LAN feature. This interface uses an RJ-45 type modular jack connector (8 pins).

J: Ethernet Interface (LAN1)

10BASE-T/100BASE-TX Auto Changeover.

This interface uses an RJ-45 type modular jack connector (8 pins).

K: USB Interface (USB)

4 ports. USB 2.0 compatible. Uses a “TYPE-A” connector.

Power supply voltage	5 VDC ±5%
Output current	Each port: 500mA (max.), 4 ports total: 500mA (max.)
Maximum communication distance	5m

L: Analog RGB Interface

A mini D-sub 15 pin (socket) is used to connect a RGB monitor on the market or FP Series unit manufactured by Pro-face.

M: Secondary CF Card Interface

Open the cover and insert the CF Card.

CF Card (Type I/II-compliant) is available. IDE-type connection. *1

N: Primary CF Card Interface

Open the cover and insert the CF Card.

CF Card (Type I/II-compliant) is available. IDE-type connection. *1

O: Power LED / RAS Status Lamp (ON)

LED	PS-B Status
Green (lit)	Normal Operation (power is on)
Green (blinking)	Soft OFF state
Orange (lit)	System Monitor Error RAS Error
Not lit	Power is OFF

P: HDD / IDE Access Lamp (DISK)

LED	PS-B Status
Green (lit)	Access to IDE.
Not lit	Not access to IDE.

IMPORTANT

- When attaching peripheral units to the PS-B, be sure the PS-B's power cord is disconnected from the main power supply.

*1 Since an IDE-type connection is used, the unit is not hot-swappable. When inserting/removing the CF Card, be sure that power is turned OFF.

1.4 Prior to Operating the PS-B Unit

1.4.1 Power Supply

About states of PS-B's power supply, there are three kinds of states, which are No Power, Active State (Normal), and Soft OFF State^{*1}. Each state is outlined in the following.

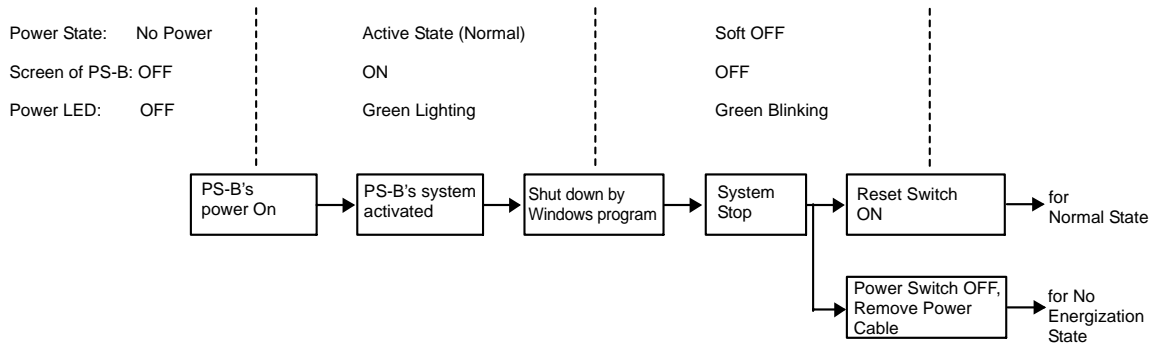

*1 The Soft OFF refers to the state that Windows[®] has been shut down and the power is provided only for the electric circuit to boot system. This Soft OFF State is different from what is System Standby set by Windows[®].

2 | Specifications

1. PS3000-BA
2. PS3001-BD

This chapter describes the general, functional and interface specifications of the PS-B as well as its part names and dimensions.

2.1 PS3000-BA

2.1.1 General Specifications

■ Electrical Specifications

Power Supply	Input Voltage	AC100/240V
	Rated Voltage	AC85 to 265V
	Rated Frequency	50/60Hz
	Allowable Voltage Drop	1 cycle or less (Voltage drop interval must be 1s or more.)
	Power Consumption	120VA or less
	Rush current	At AC100V (normal temperature): 30A or less At AC240V (normal temperature): 50A or less
Voltage Endurance		AC1500V 20mA for 1minute (between charging and FG terminals)
Insulation Resistance		DC500V 10MΩ (min.) (between charging and FG terminals)

■ Environmental Specifications

Physical	Surrounding Air Temperature	0 to 50°C: without HDD 5 to 50°C: with HDD
	Storage Temperature	-20 to +60°C
	Ambient Humidity	10 to 90%RH (Not condensing, wet bulb temperature: 39°C or less. Wet bulb temperature with HDD: 29°C or less.)
	Storage Humidity	10 to 90%RH (Not condensing, wet bulb temperature: 39°C or less.)
	Dust	Free of dust
	Pollution Degree	For use in Pollution Degree 2 environment
	Corrosive gas	Free of corrosive gases
	Atmosphere (Using height)	800 to 1114hPa (-300 to 2,000 meters above sea-level and below)
Mechanical	Vibration Resistance	<Without HDD> IEC61131-2 compliant 5 to 9Hz single-amplitude 3.5mm 9 to 150Hz constant-accelerated velocity 9.8m/s ² X, Y, Z directions for 10 cycle (100 minute) <With HDD> 4.9m/s ² (10 to 25Hz X,Y,Z directions for 30 minute)
Electrical	Noise Immunity	Noise Voltage: 1500V _{P-P} Pulse Duration: 50ns, 500ns, 1μs Rise Time: 1ns (via noise simulator)
	Electrostatic Discharge Immunity	6kV (complies with EN 61000-4-2 Level 3)
Noise Immunity (Fast Transient Burst Noise)		Power supply line: 2kV (IEC61000-4-4) COM port: 1kV (IEC61000-4-4)

IMPORTANT

- When using any of the PS-B's optional devices, be sure to check that device's specifications for any special conditions or cautions that may apply to its use.
- Be aware that not only does the Hard Disk have a fixed lifetime, but that accidents can always occur. Therefore, be sure to back up your Hard Disk's data regularly, or prepare another Hard Disk unit that can be used for backup.
- The Hard Disk lifetime given here may be reduced due to unforeseen environmental factors, however, generally speaking, the disk should last for 20,000 hours (of operation) or approximately 5 years, whichever comes first at an operating temperature of 20°C and 333 hours of operation per month. (HDD access frequency of 20% or less)
- Using the Hard Disk in an environment that is excessively hot and/or humid will shorten the disk's usage lifetime. A wet bulb temperature of 29°C or less is recommended. This is equivalent to the following data.

Temperature	Humidity
at 35°C	no higher than 64% RH
at 40°C	no higher than 44% RH

- In order to extend the lifetime of the hard disk, Pro-face recommends you set the Windows® 2000's [Control panel]-[Power Options]-[Turn off hard disks] selection or the Windows® XP's [Control panel]-[Performance and Maintenance]-[Power Management option]-[Turn off hard disks] selection to turn the hard disk off when the unit is not being operated. A setting of 5 minutes is recommended.

■ Structural Specifications

Installation	Grounding	Protective grounding: D type (Same for FG and SG terminals) Functional grounding: D type (Same for FG and SG terminals)
	Structure	Rating: Equivalent to IP20 Feature size: All-in-one Installation configuration: In-cabin installation
	Cooling Method	Forced cooling by unit fan
	Weight	Approx. 3.0kg [6.6lb] max. (unit only)
	External Dimensions	W255mm [10.04in] X H164mm [6.46in] X D124mm [4.88in]

2.1.2 Performance Specifications

■ Performance Specifications

CPU	ULV Intel® Celeron® M (1GHz)				
L2 Cache Memory	Not installed				
Main Memory	1Slot (Max.1GB) SO-DIMM socket 256MB to 1GB (PC2700)				
Chipset	Intel® 855GME+ICH4				
Graphic accelerator	Built-in Intel® 855GME				
BIOS	FirstBIOS Embedded Pro (Phoenix Technologies Co.)				
Graphics	VGA (640 x 480 pixels) to (1920 x 1080 pixels)				
Video Memory	Max.64MB (When using Windows®) UMA Type				
Interface	Serial (RS-232C)	COM1	D-sub 9 pin (plug)		
		COM2	D-sub 9 pin (plug) (RS-232C/RS-422/RS-485 switch possible. RI/+5V switch possible.)		
	Disk	IDE I/F	Primary *1	Master	2.5inch HDD I/F
				Slave	CF Card I/F
			Secondary	Master	CF Card I/F
	USB	USB 2.0 compatible front 4 ports Connector: USB type A Power Supply Voltage: DC5V±5% Output Current: Each port: 500mA (max.), 4 ports total: 500mA (max.) Maximum communication distance: 5m			
	LAN	Front 2 ports. This interface uses an RJ-45 type modular jack connector (8 pins). LAN1: auto change to 10BASE-T/100BASE-TX LAN2: auto change to 10BASE-T/100BASE-TX/1000BASE-T, corresponding to Wake On LAN feature			
	Sound	SPEAKER OUT Front 1 port (A mini pin jack connector is used.)			
	Analog RGB	Front 1 port. Mini D-sub 15 pin (socket).			
	PCI	Rev.2.2 compatible PCI I/F (5V) side 1 Port			
Clock Accuracy *2	±180 sec. /month (timing error depending on temperature and power-off)				

*1 To change the Master/Slave setting of Primary IDE I/F, set Serial Mode Select Switch #9 pin on the circuit board to the desired position.

SEE → ◆ Switches (page 2-10)

*2 The clock, RTC, built-in the PS-B has a timing error. The range if the error will be between +300 and -300 sec. / month, depending on the PS-B's conditions such as life-time usage or temperature difference. If you use the PS-B in a system where timing is critical, adjust the clock at regular intervals.

■ Expansion Slots

Slot Type	PCI 2.2(5V)			
Board Size	106.68 x 174.63mm [4.20 x 6.88in.]			
Power Supply Capacity	DC5V	DC12V	DC-12V	DC3.3V
Power Consumption	1.0A	0.25A	0.1A	0.5A

- ◆ About power consumption load factor for PCI board and temperature derating

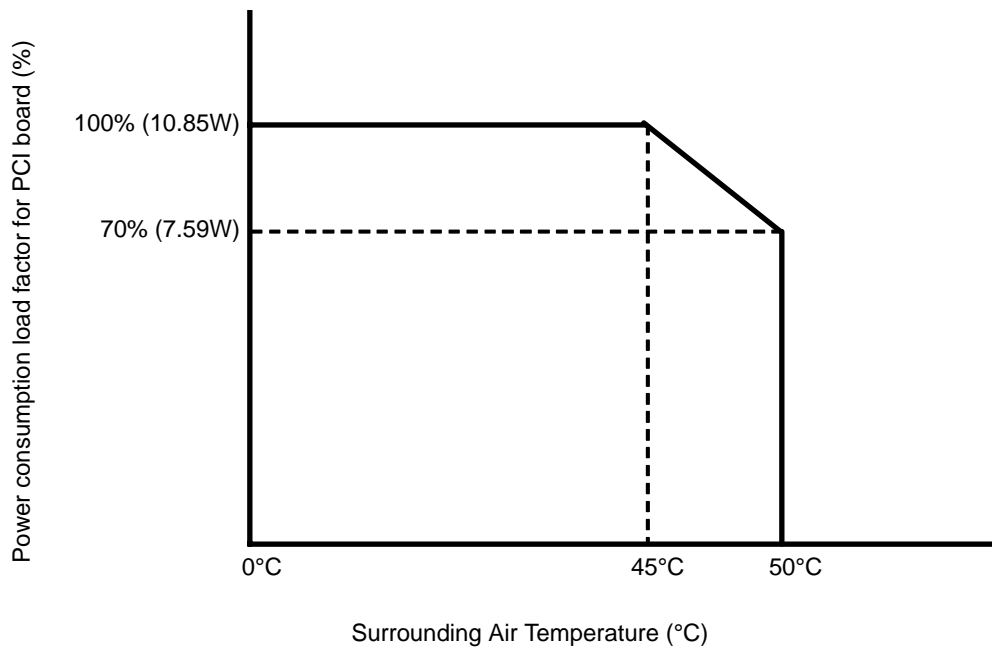

2.1.3 Interface Specifications

This section describes the specifications of each interface of the PS3000-BA unit.

IMPORTANT

- This PS-B unit's serial port is not isolated. When the host (PLC) unit is also not isolated, and to reduce the risk of damaging the RS-232C/RS-422/RS-485 circuit, be sure to connect the #5 SG (Signal Ground) terminal.

■ Serial Interface (COM1,COM2)

Interfit Bracket	#4-40 (UNC)
------------------	-------------

◆ COM1

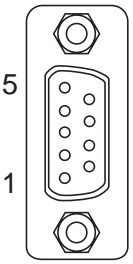
Pin Arrangement	Pin No.	RS-232C		
		Signal Name	Direction	Meaning
 <p>(PS-B side)</p>	1	CD	Input	Carrier Detect
	2	RD(RXD)	Input	Receive Data
	3	SD(TXD)	Output	Send Data
	4	ER(DTR)	Output	Data Terminal Ready
	5	GND	-	Signal Ground
	6	DR(DSR)	Input	Data Set Ready
	7	RS(RTS)	Output	Request to Send
	8	CS(CTS)	Input	Clear to Send
	9	CI(RI)	Input	Called status display
	FG	FG	-	Frame Ground (Common with SG)

◆ COM2

COM2 can be changed to either RS-232C, RS-422 or RS-485. (The factory setting is RS-232C.) To change this setting, set Serial Mode Select Switch on the circuit board to the desired position.

SEE → ◆ *Switches (page 2-10)*

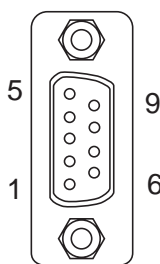
Pin Arrangement	Pin No.	RS-232C		
		Signal Name	Direction	Meaning
 <p>(PS-B side)</p>	1	CD	Input	Carrier Detect
	2	RD(RXD)	Input	Receive Data
	3	SD(TXD)	Output	Send Data
	4	ER(DTR)	Output	Data Terminal Ready
	5	GND	-	Signal Ground
	6	DR(DSR)	Input	Data Set Ready
	7	RS(RTS)	Output	Request to Send
	8	CS(CTS)	Input	Clear to Send
	9	CI(RI)/+5V*1	Input / Output	Called status display / +5V Output (Switching available)
	FG	FG	-	Frame Ground (Common with SG)

*1 To change the RI/+5V setting of #9 pin set System Set switch to the desired position.

Pin No.	RS-422		
	Signal Name	Direction	Meaning
1	RDA	Input	Receive Data A (+)
2	RDB	Input	Receive Data B (-)
3	SDA	Output	Send Data A (+)
4	NC	-	No Connection
5	GND	-	Signal Ground
6	NC	-	No Connection
7	SDB	Output	Send Data B (-)
8	NC	-	No Connection
9	NC	-	No Connection
FG	FG	-	Frame Ground (Common with SG)

Pin No.	RS-485		
	Signal Name	Direction	Meaning
1	DATA +	Input / Output	Send/Receive Data (+)
2	DATA -	Input / Output	Send/Receive Data (-)
3	NC	-	No Connection
4	NC	-	No Connection
5	GND	-	Signal Ground
6	NC	-	No Connection
7	NC	-	No Connection
8	NC	-	No Connection
9	NC	-	No Connection
FG	FG	-	Frame Ground (Common with SG)

IMPORTANT

- Be sure to connect pin number 5 (GND) of COM1, COM2 (RS-232C) to the host unit's Signal Ground terminal.
- Be sure to confirm what settings will be used by the other device and set the slide switches accordingly. Failure to do so can result in a unit malfunction or damage.
- Whenever changing the PS-B switches, be sure to first turn the PS-B's power supply OFF. Failure to do so can cause a PS-B malfunction.
- Connect the FG terminal line to the shell.
- FG and SG terminals are internally connected in the PS-B. When connecting to another device, be sure not to create an SG shorting loop in your system.

◆ Switches

The following switch settings corresponding to each Serial Interface need to be signified. The switches are on the PS-B's circuit board.

- To change the switch settings

The switches are on the PS-B's circuit board. First of all, remove the cover.

<For PS3000-BA without built-in HDD unit>

- (1) Unscrew the screws (2) from the Expansion Board Cover, and remove the cover. When replacing the cover, the torque required for these screws is 0.5 to 0.6N•m.

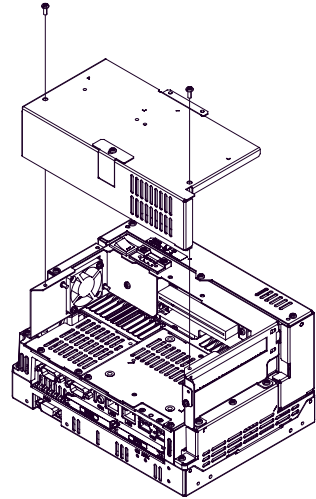

- (2) Unscrew the screws (2) of the IDE cover and remove the IDE cover. When replacing the cover, the torque required for these screws is 0.5 to 0.6N•m.

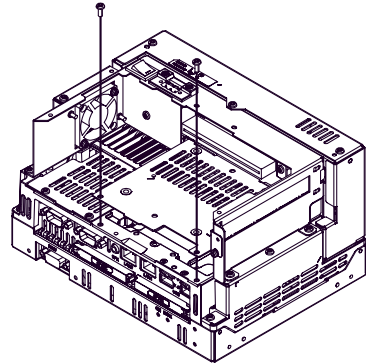

<For PS3000-BA with built-in HDD unit>

- (1) Unscrew the screws (2) from the Expansion Board Cover, and remove the cover. When replacing the cover, the torque required for these screws is 0.5 to 0.6N•m.

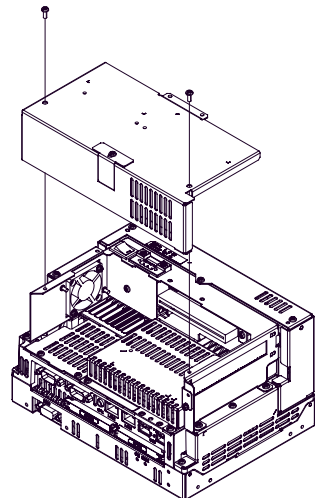

- (2) Unscrew the screws (2) of the HDD cover and remove the HDD cover. When replacing the cover, the torque required for these screws is 0.5 to 0.6N•m.

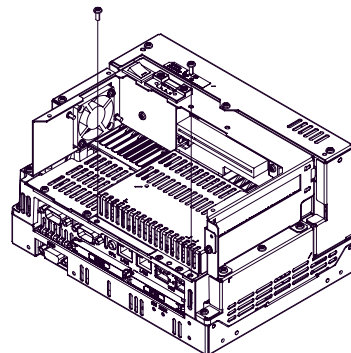

- (3) Unscrew the screws (4) of the HDD unit, remove the cable connector from IDE I/F while lifting up the HDD unit, and remove it. To replace the HDD unit, connect the cable connector to IDE I/F securely and fix the HDD unit with the screws (4). (For the location of the IDE I/F, refer to the following figure “Inside of the top”.) The torque required for these screws is 0.5 to 0.6N•m.

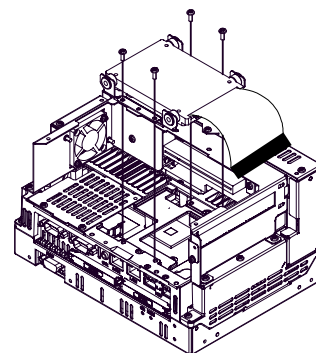

• About Switches

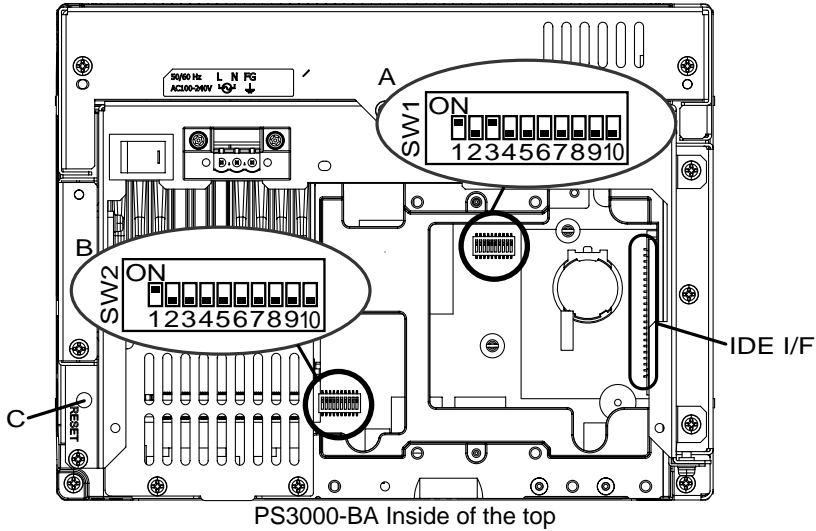

Switch Location	Switch Name	Description
A	System Set SW (SW1)	10-point dip switch. For System Set SW and factory settings details, see Table (1).
B	Serial Mode Select SW (SW2)	10-point dip switch. Designates COM2 communication settings. For Serial Mode Select SW details, see Table (2). Factory Settings: For RS-232C
C	Reset SW	<p>■Power Button Mode In advance, turn ON the System Set SW No.6. For Windows® 2000, the mode of [When I press the power button on my computer] that is selected from PS-B's start menu-[Settings]-[Control panel]-[Power Options]-[Advanced]-[Power buttons] is operated when pressing the Reset SW. For Windows® XP, the mode of [When I press the power button on my computer] that is selected from [Control panel]-[Performance and Maintenance]-[Power Management option]-[Advanced] is operated.</p> <p>NOTE</p> <ul style="list-style-type: none"> PS-B restarts when pressing the switch at the Soft OFF*1 state (the Power LED / RAS Status Lamp is blinking in green). <p>■Reset Switch Mode In advance, turn OFF the System Set SW No.6. PS-B restarts when pressing the Reset SW.</p>

*1 The Soft OFF refers to the state that Windows® has been shut down and the power is provided only for the electric circuit to boot system. This Soft OFF State is different from what is System Standby set by Windows®.

Switch No.	Description	ON	OFF	Notes
1	Used for the system.	Reserved	Reserved	Factory Settings: ON
2	Used for the system.	Reserved	Reserved	Factory Settings: OFF
3	Used for the system.	Reserved	Reserved	Factory Settings: ON
4	Used for the system.	Reserved	Reserved	Factory Settings: OFF
5	Used for the system.	Reserved	Reserved	Factory Settings: OFF
6	Changes Reset SW mode.	Power button	Reset SW	Factory Settings: OFF
7	Used for the system.	Reserved	Reserved	Factory Settings: OFF
8	Changes COM2 (RI <---> +5V). (enabled only when RS-232C mode)	+5V Output	RI	Factory Settings: OFF
9	Changes a Master/Slave setting for Primary CF Card Interface.	Slave	Master	The factory settings depend on your selected built-in accessory.
10	Used for the system.	Reserved	Reserved	Factory Settings: OFF

Table 1) System Set Switches

Switch Number	Description	ON	OFF	RS-232C	RS-422	RS-485
1	Changes COM2's communication method	RS-232C	RS-422 / RS-485	ON	OFF* ¹	OFF* ¹
2	Changes COM2's communication method	RS-422 / RS-485	RS-232C	OFF	ON	ON
3	Changes COM2's communication method	RS-422 / RS-485	RS-232C	OFF	ON	ON
4	Changes TX data's output mode	TX data output is controlled via the RTS signal.	TX data output is NOT controlled via the RTS signal. (normally output)	OFF	ON/OFF	ON/OFF* ³
5	Switches the TX termination resistance ON/OFF	Inserts termination resistance of 220Ω between TXA and TXB.	No termination	OFF	ON	ON/OFF* ²
6	Switches the RX termination resistance ON/OFF	Inserts termination resistance of 220Ω between RXA and RXB.	No termination	OFF	ON	ON/OFF* ²
7	Switches the shorting of TXA and RXA ON/OFF	Shorts TXA and RXA. (RS-485 mode)	No shorting (RS-422 mode)	OFF	OFF	ON
8	Switches the shorting of TXB and RXB ON/OFF	Shorts TXB and RXB. (RS-485 mode)	No shorting (RS-422 mode)	OFF	OFF	ON
9	RTS Automatic control mode	The data is automatically controlled via the RTS signal.	The data is not automatically controlled via the RTS signal.	OFF	OFF	ON/OFF* ³
10	(enabled only when RS-485 mode)	The data is automatically controlled via the RTS signal.	The data is not automatically controlled via the RTS signal.	OFF	OFF	ON/OFF* ³

Table2) Serial Mode Select Switches

- *1 Be sure to keep the settings, "OFF" for RS-422 or RS-485.
- *2 If you use the termination resistance, base your settings on the connection specifications.
- *3 To control TX output driver via RTS automatically, set ON. Be sure to set SW No.4 OFF.
To control TX output driver via RTS signal, set OFF. Be sure to set SW No.4 ON.

Serial Mode Select Switches (SW4 to SW10) operate as shown in the circuit diagram below.

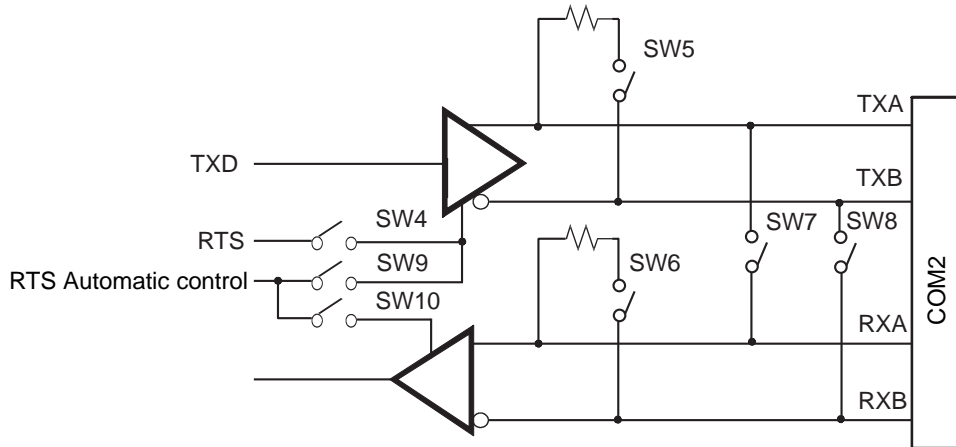

2.1.4 Dimensions

The following dimensions apply to PS3000-BA.

■ Installation Fasteners Attached Dimensions

Unit: mm[in.]

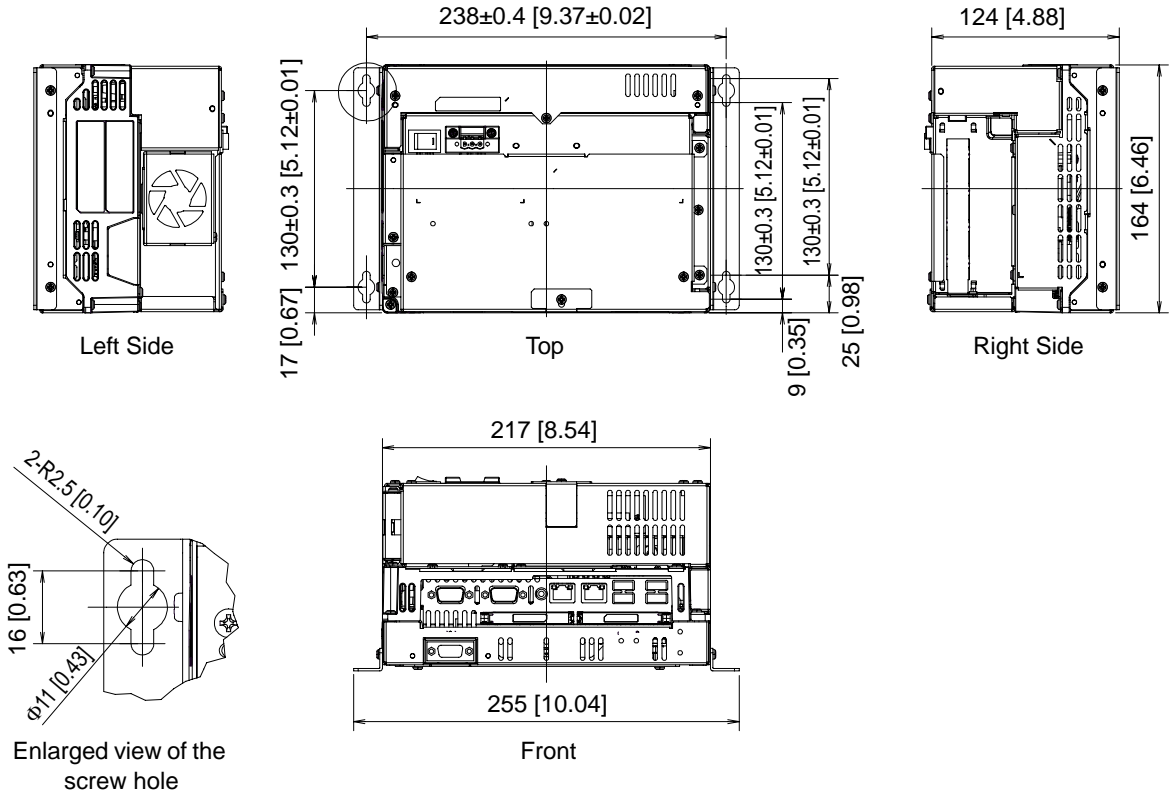

■ Cable Attached Dimensions

Unit: mm[in.]

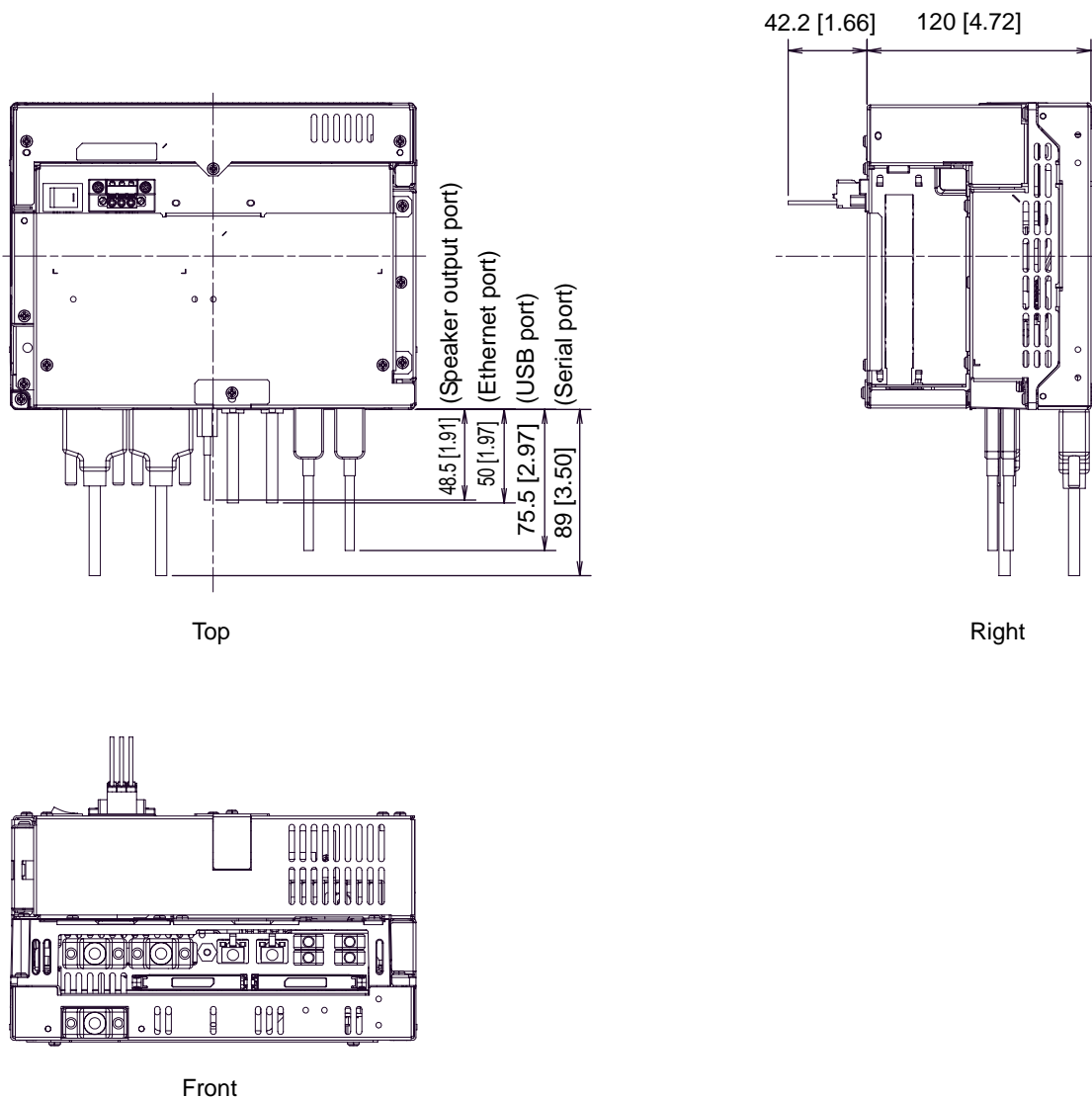

IMPORTANT

- All the above values are designed in case of cable bending. The dimensions given here are representative values depending on the type of connection cable used. Therefore, they are all intended for reference only.

■ Dimensions of the Screw Holes

Use the following dimension drawings to drill the attachment bracket attachment screw holes in the installation panel. Use M4 size screws.

Unit: mm [in.]

◆ Horizontal mounting / Wall mounting 1

4-M4 [0.16]

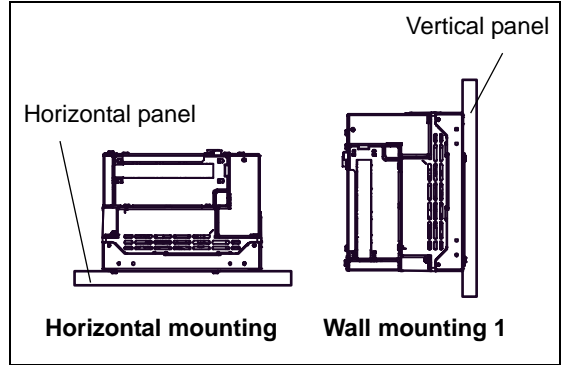
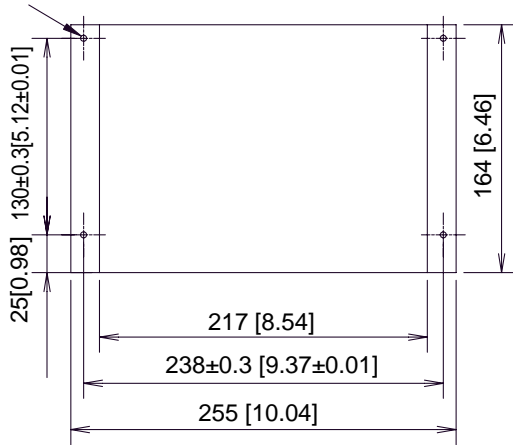

◆ Wall mounting 2

4-M4 [0.16]

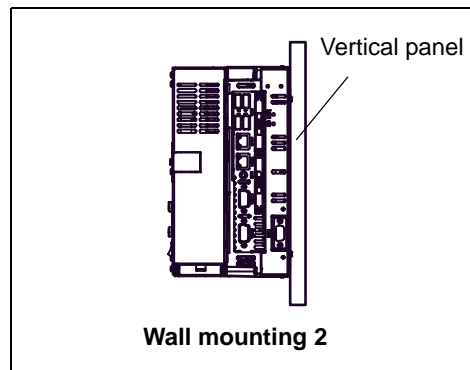
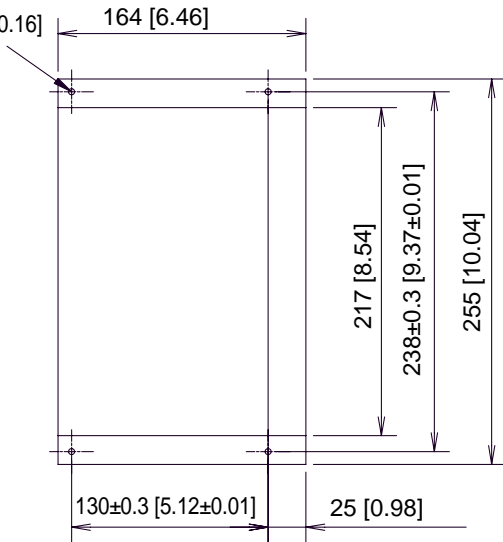

2.2 PS3001-BD

2.2.1 General Specifications

■ Electrical Specifications

Power Supply	Input Voltage	DC24V
	Rated Voltage	DC19.2 to 28.8V
	Allowable Voltage Drop	5ms (max.)
	Power Consumption	40W or less
	Rush current	30A (max.) (Ambient Temperature)
Voltage Endurance		AC500V 20mA for 1minute (between charging and FG terminals)
Insulation Resistance		DC500V 10MΩ(min.) (between charging and FG terminals)

■ Environmental Specifications

Physical	Surrounding Air Temperature	0 to 50°C
	Storage Temperature	-20 to +60°C
	Ambient Humidity	10 to 90%RH (Not condensing, wet bulb temperature: 39°C or less.)
	Storage Humidity	10 to 90%RH (Not condensing, wet bulb temperature: 39°C or less.)
	Dust	Free of dust
	Pollution Degree	For use in Pollution Degree 2 environment
	Corrosive gas	Free of corrosive gases
	Atmosphere (Using height)	800 to 1114hPa (-300 to 2,000 meters above sea-level and below)
Mechanical	Vibration Resistance	IEC61131-2 compliant 5 to 9Hz single-amplitude 3.5mm 9 to 150Hz constant-accelerated velocity 9.8m/s ² X, Y, Z directions for 10 cycle (100 minute)
Electrical	Noise Immunity	Noise Voltage: 1500V _{P-P} Pulse Duration: 50ns, 500ns, 1μs Rise Time: 1ns (via noise simulator)
	Electrostatic Discharge Immunity	6kV (complies with EN 61000-4-2 Level 3)
Noise Immunity (Fast Transient Burst Noise)		Power supply line: 2kV (IEC61000-4-4) COM port: 1kV (IEC61000-4-4)

IMPORTANT

- When using any of the PS-B's optional devices, be sure to check that device's specifications for any special conditions or cautions that may apply to its use.

■ Structural Specifications

Installation	Grounding	Protective grounding: D type (Same for FG and SG terminals) Functional grounding: D type (Same for FG and SG terminals)
	Structure	Rating: Equivalent to IP20 Feature size: All-in-one Installation configuration: In-cabin installation
	Cooling Method	Natural air circulation
	Weight	Approx. 2.0kg [4.4lb] max. (unit only)
	External Dimensions	W255mm [10.04in] X H164mm [6.46in] X D68.8mm [2.71in]

2.2.2 Performance Specifications

■ Performance Specifications

CPU	ULV Intel® Celeron® M (600MHz)				
L2 Cache Memory	512KB				
Main Memory	1Slot (Max.1GB) SO-DIMM socket 256MB to 1GB (PC2700)				
Chipset	Intel® 855GME+ICH4				
Graphic accelerator	Built-in Intel® 855GME				
BIOS	FirstBIOS Embedded Pro (Phoenix Technologies Co.)				
Graphics	SVGA (800 x 600 pixels) to (1920 x 1080 pixels)				
Video Memory	Max.64MB (When using Windows®) UMA Type				
Interface	Serial (RS-232C)	COM1	D-sub 9 pin (plug)		
		COM2	D-sub 9 pin (plug) (RS-232C/RS-422/RS-485 switch possible. RI/+5V switch possible.)		
	Disk	IDE I/F	Primary	Master	CF Card I/F
			Secondary	Master	CF Card I/F
	USB	USB 2.0 compatible front 4 ports Connector: USB type A Power Supply Voltage: DC5V±5% Output Current: Each port: 500mA (max.), 4 ports total: 500mA (max.) Maximum communication distance: 5m			
	LAN	Front 2 ports. This interface uses an RJ-45 type modular jack connector (8 pins). LAN1: auto change to 10BASE-T/100BASE-TX LAN2: auto change to 10BASE-T/100BASE-TX/1000BASE-T, corresponding to Wake On LAN feature			
	Sound	SPEAKER OUT Front 1 port (A mini pin jack connector is used.)			
	Analog RGB	Front 1 port. Mini D-sub 15 pin (socket).			
Clock Accuracy*1	±180 sec. /month (timing error depending on temperature and power-off)				

*1 The clock, RTC, built-in the PS-B has a timing error. The range of the error will be between +300 and -300 sec. / month, depending on the PS-B's conditions such as lifetime usage or temperature difference. If you use the PS-B in a system where timing is critical, adjust the clock at regular intervals.

2.2.3 Interface Specifications

This section describes the specifications of each interface of the PS3001-BD unit.

IMPORTANT

- This PS-B unit's serial port is not isolated. When the host (PLC) unit is also not isolated, and to reduce the risk of damaging the RS-232C/RS-422/RS-485 circuit, be sure to connect the #5 SG (Signal Ground) terminal.

■ Serial Interface (COM1,COM2)

Interfit Bracket	#4-40 (UNC)
------------------	-------------

◆ COM1

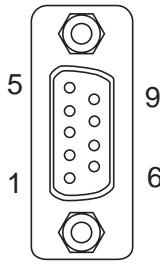
Pin Arrangement	Pin No.	RS-232C		
		Signal Name	Direction	Meaning
 <p>(PS-B side)</p>	1	CD	Input	Carrier Detect
	2	RD(RXD)	Input	Receive Data
	3	SD(TXD)	Output	Send Data
	4	ER(DTR)	Output	Data Terminal Ready
	5	GND	-	Signal Ground
	6	DR(DSR)	Input	Data Set Ready
	7	RS(RTS)	Output	Request to Send
	8	CS(CTS)	Input	Clear to Send
	9	CI(RI)	Input	Called status display
	FG	FG	-	Frame Ground (Common with SG)

◆ COM2

COM2 can be changed to either RS-232C, RS-422 or RS-485. (The factory setting is RS-232C.) To change this setting, set Serial Mode Select Switch on the circuit board to the desired position.

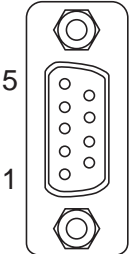

◆ *Switches (page 2-25)*

Pin Arrangement	Pin No.	RS-232C		
		Signal Name	Direction	Meaning
 (PS-B side)	1	CD	Input	Carrier Detect
	2	RD(RXD)	Input	Receive Data
	3	SD(TXD)	Output	Send Data
	4	ER(DTR)	Output	Data Terminal Ready
	5	GND	-	Signal Ground
	6	DR(DSR)	Input	Data Set Ready
	7	RS(RTS)	Output	Request to Send
	8	CS(CTS)	Input	Clear to Send
	9	CI(RI)/+5V*1	Input / Output	Called status display / +5V Output (Switching available)
	FG	FG	-	Frame Ground (Common with SG)

*1 To change the RI/+5V setting of #9 pin set System Set switch to the desired position.

Pin No.	RS-422		
	Signal Name	Direction	Meaning
1	RDA	Input	Receive Data A (+)
2	RDB	Input	Receive Data B (-)
3	SDA	Output	Send Data A (+)
4	NC	-	No Connection
5	GND	-	Signal Ground
6	NC	-	No Connection
7	SDB	Output	Send Data B (-)
8	NC	-	No Connection
9	NC	-	No Connection
FG	FG	-	Frame Ground (Common with SG)

Pin No.	RS-485		
	Signal Name	Direction	Meaning
1	DATA +	Input / Output	Send/Receive Data (+)
2	DATA -	Input / Output	Send/Receive Data (-)
3	NC	-	No Connection
4	NC	-	No Connection
5	GND	-	Signal Ground
6	NC	-	No Connection
7	NC	-	No Connection
8	NC	-	No Connection
9	NC	-	No Connection
FG	FG	-	Frame Ground (Common with SG)

IMPORTANT

- Be sure to connect pin number 5 (GND) of COM1, COM2 (RS-232C) to the host unit's Signal Ground terminal.
- Be sure to confirm what settings will be used by the other device and set the slide switches accordingly. Failure to do so can result in a unit malfunction or damage.
- Whenever changing the PS-B switches, be sure to first turn the PS-B's power supply OFF. Failure to do so can cause a PS-B malfunction.
- Connect the FG terminal line to the shell.
- FG and SG terminals are internally connected in the PS-B. When connecting to another device, be sure not to create an SG shorting loop in your system.

◆ Switches

The following switch settings corresponding to each Serial Interface need to be signified. The switches are on the PS-B's circuit board.

- To change the switch settings

The switches are on the PS-B's circuit board. First of all, remove the cover.

Unscrew the screws (2) of the Maintenance Cover and remove the Maintenance Cover. When replacing the cover, the torque required for these screws is 0.5 to 0.6N•m.

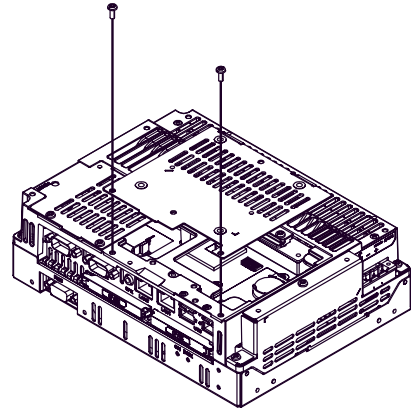

• About Switches

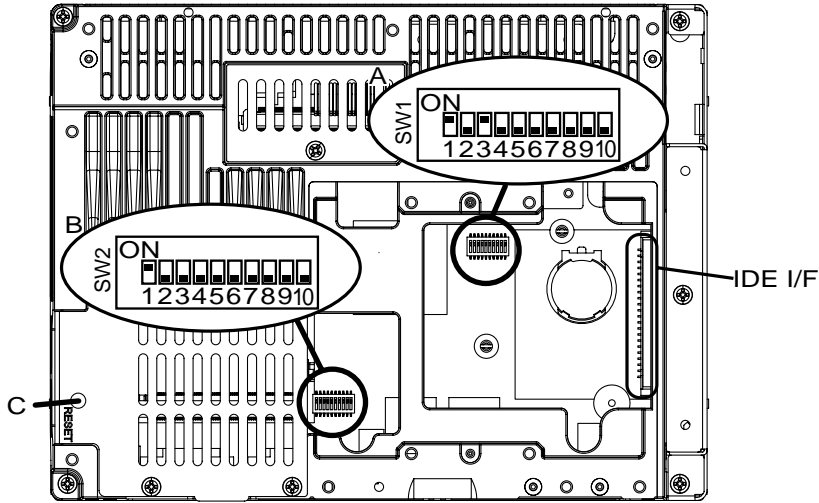

PS3001-BD Inside of the top

Switch Location	Switch Name	Description
A	System Set SW (SW1)	10-point dip switch. For System Set SW and factory settings details, see Table (1).
B	Serial Mode Select SW (SW2)	10-point dip switch. Designates COM2 communication settings. For Serial Mode Select SW details, see Table (2). Factory Settings: For RS-232C
C	Reset SW	<p>■Power Button Mode In advance, turn ON the System Set SW No.6. For Windows® 2000, the mode of [When I press the power button on my computer] that is selected from PS-B's start menu-[Settings]-[Control panel]-[Power Options]-[Advanced]-[Power buttons] is operated when pressing the Reset SW. For Windows® XP, the mode of [When I press the power button on my computer] that is selected from [Control panel]-[Performance and Maintenance]-[Power Management option]-[Advanced] is operated.</p> <p>NOTE</p> <ul style="list-style-type: none"> PS-B restarts when pressing the switch at the Soft OFF*1 state (the Power LED / RAS Status Lamp is blinking in green). <p>■Reset Switch Mode In advance, turn OFF the System Set SW No.6. PS-B restarts when pressing the Reset SW.</p>

*1 The Soft OFF refers to the state that Windows® has been shut down and the power is provided only for the electric circuit to boot system. This Soft OFF State is different from what is System Standby set by Windows®.

Switch No.	Description	ON	OFF	Notes
1	Used for the system.	Reserved	Reserved	Factory Settings: ON
2	Used for the system.	Reserved	Reserved	Factory Settings: OFF
3	Used for the system.	Reserved	Reserved	Factory Settings: ON
4	Used for the system.	Reserved	Reserved	Factory Settings: OFF
5	Used for the system.	Reserved	Reserved	Factory Settings: OFF
6	Changes Reset SW mode.	Power button	Reset SW	Factory Settings: OFF
7	Used for the system.	Reserved	Reserved	Factory Settings: OFF
8	Changes COM2 (RI <---> +5V). (enabled only when RS-232C mode)	+5V Output	RI	Factory Settings: OFF
9	Changes a Master/Slave setting for Primary CF Card Interface.	Slave	Master	Factory Settings: OFF *1
10	Used for the system.	Reserved	Reserved	Factory Settings: OFF

Table 1) System Set Switches

*1 Be sure to use No.9 switch with factory settings (OFF).

Switch Number	Description	ON	OFF	RS-232C	RS-422	RS-485
1	Changes COM2's communication method	RS-232C	RS-422 / RS-485	ON	OFF* ¹	OFF* ¹
2	Changes COM2's communication method	RS-422 / RS-485	RS-232C	OFF	ON	ON
3	Changes COM2's communication method	RS-422 / RS-485	RS-232C	OFF	ON	ON
4	Changes TX data's output mode	TX data output is controlled via the RTS signal.	TX data output is NOT controlled via the RTS signal. (normally output)	OFF	ON/OFF	ON/OFF* ³
5	Switches the TX termination resistance ON/OFF	Inserts termination resistance of 220Ω between TXA and TXB.	No termination	OFF	ON	ON/OFF* ²
6	Switches the RX termination resistance ON/OFF	Inserts termination resistance of 220Ω between RXA and RXB.	No termination	OFF	ON	ON/OFF* ²
7	Switches the shorting of TXA and RXA ON/OFF	Shorts TXA and RXA. (RS-485 mode)	No shorting (RS-422 mode)	OFF	OFF	ON
8	Switches the shorting of TXB and RXB ON/OFF	Shorts TXB and RXB. (RS-485 mode)	No shorting (RS-422 mode)	OFF	OFF	ON
9	RTS Automatic control mode	The data is automatically controlled via the RTS signal.	The data is not automatically controlled via the RTS signal.	OFF	OFF	ON/OFF* ³
10	(enabled only when RS-485 mode)	The data is automatically controlled via the RTS signal.	The data is not automatically controlled via the RTS signal.	OFF	OFF	ON/OFF* ³

Table2) Serial Mode Select Switches

- *1 Be sure to keep the settings, "OFF" for RS-422 or RS-485.
- *2 If you use the termination resistance, base your settings on the connection specifications.
- *3 To control TX output driver via RTS automatically, set ON. Be sure to set SW No.4 OFF.
To control TX output driver via RTS signal, set OFF. Be sure to set SW No.4 ON.

Serial Mode Select Switches (SW4 to SW10) operate as shown in the circuit diagram below.

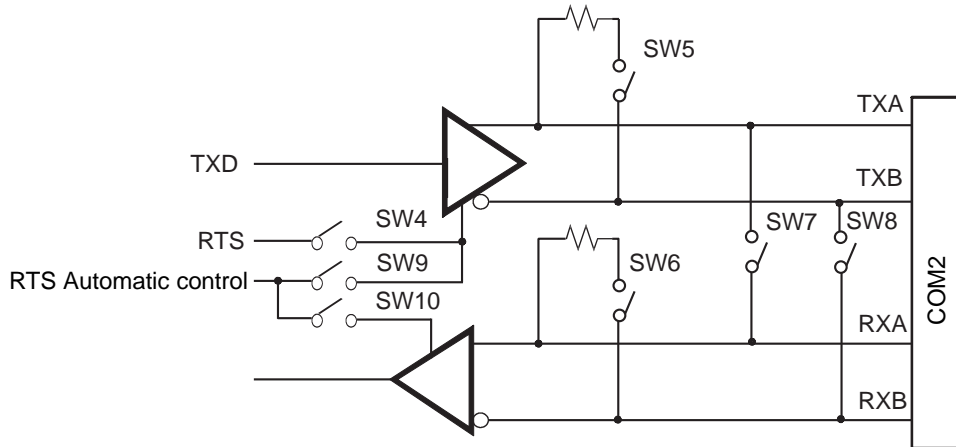

2.2.4 Dimensions

The following dimensions apply to PS3001-BD.

■ Installation Fasteners Attached Dimensions

Unit: mm[in.]

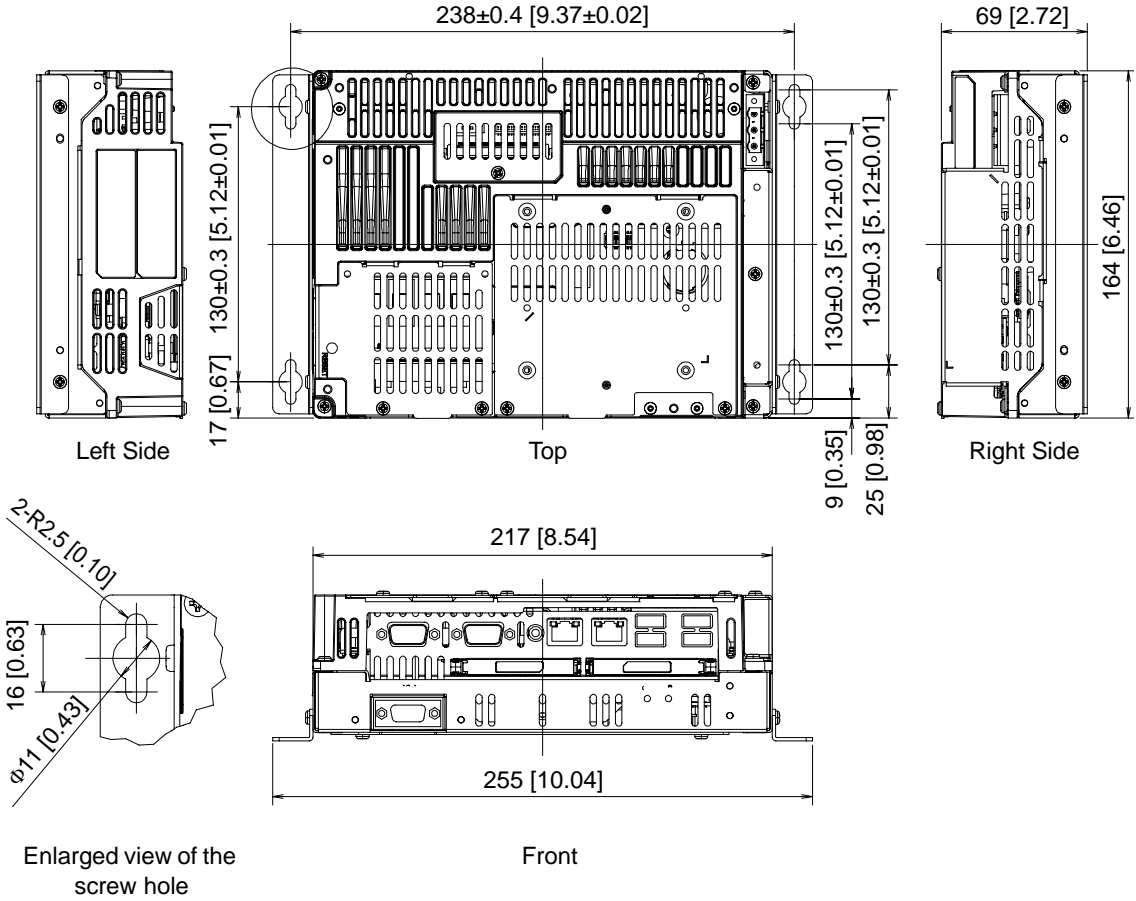

■ Cable Attached Dimensions

Unit: mm[in.]

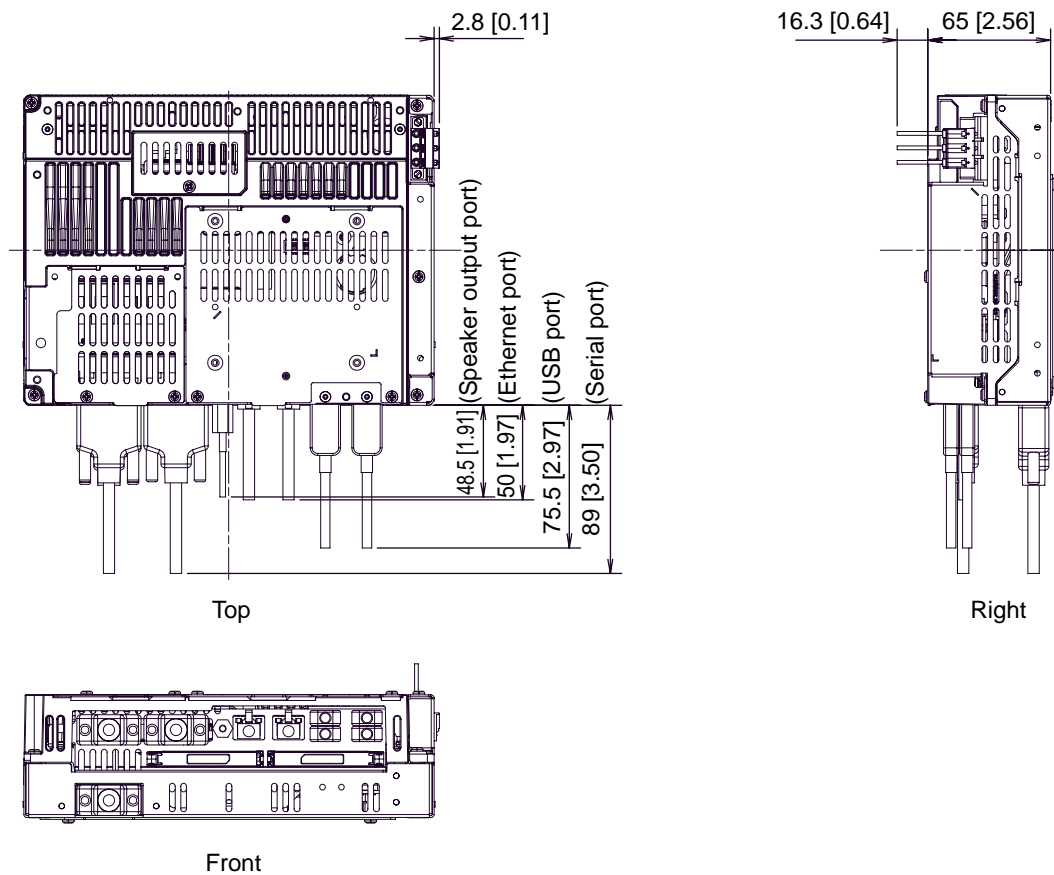

IMPORTANT

- All the above values are designed in case of cable bending. The dimensions given here are representative values depending on the type of connection cable used. Therefore, they are all intended for reference only.

■ Dimensions of the Screw Holes

Use the following dimension drawings to drill the attachment bracket attachment screw holes in the installation panel. Use M4 size screws.

Unit: mm [in.]

◆ Horizontal mounting / Wall mounting 1

4-M4 [0.16]

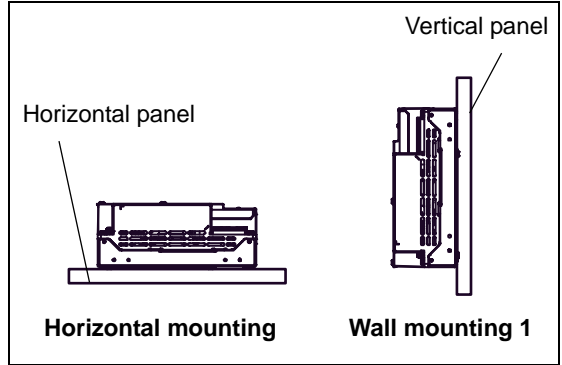
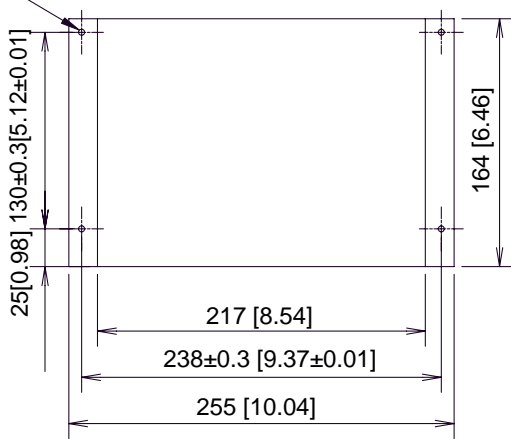

◆ Wall mounting 2

4-M4 [0.16]

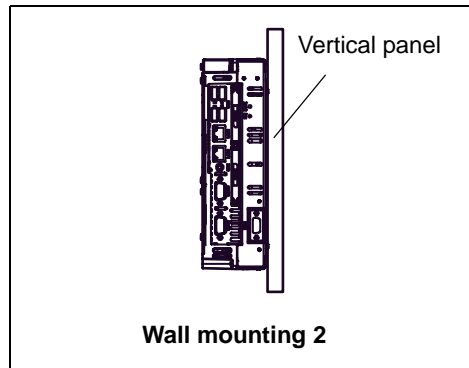
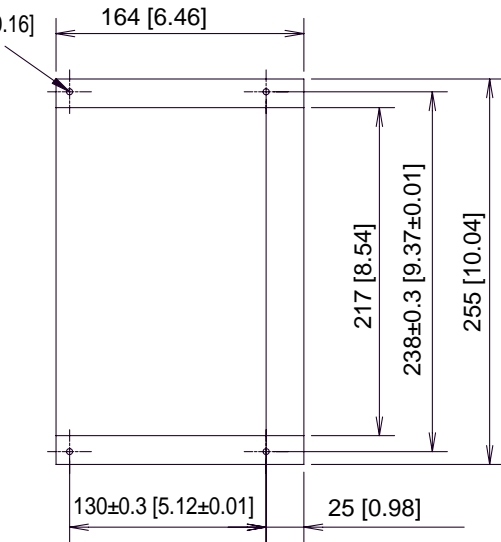

3



Installation and Wiring

1. Installation • Uninstallation
2. Peripheral Devices Installation
3. Wiring Precautions

3.1 Installation • Uninstallation

3.1.1 Installation

This section describes the procedures and precautions for installing the PS-B units.

■ Installation Requirements

The PS-B unit can be mounted horizontally on a panel as well as attached to a wall. To prevent abnormally high temperatures from occurring inside the PS-B unit, mount the unit on a horizontal panel or attach it to a vertical wall.

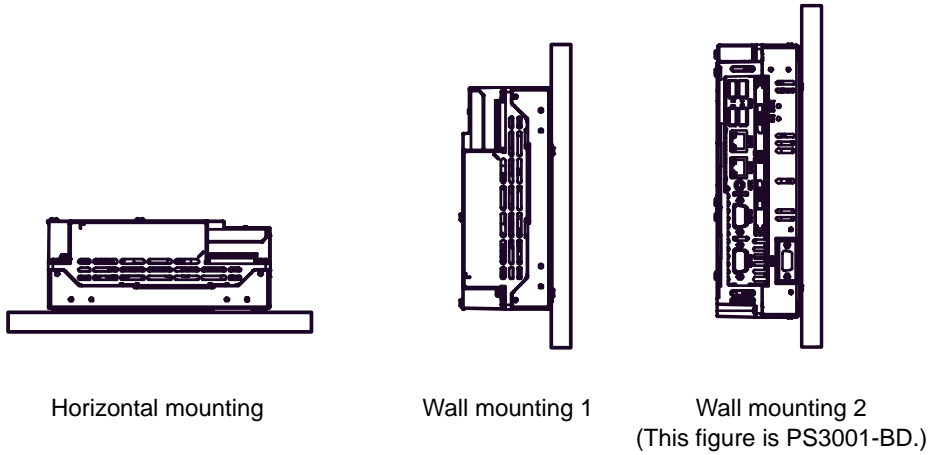
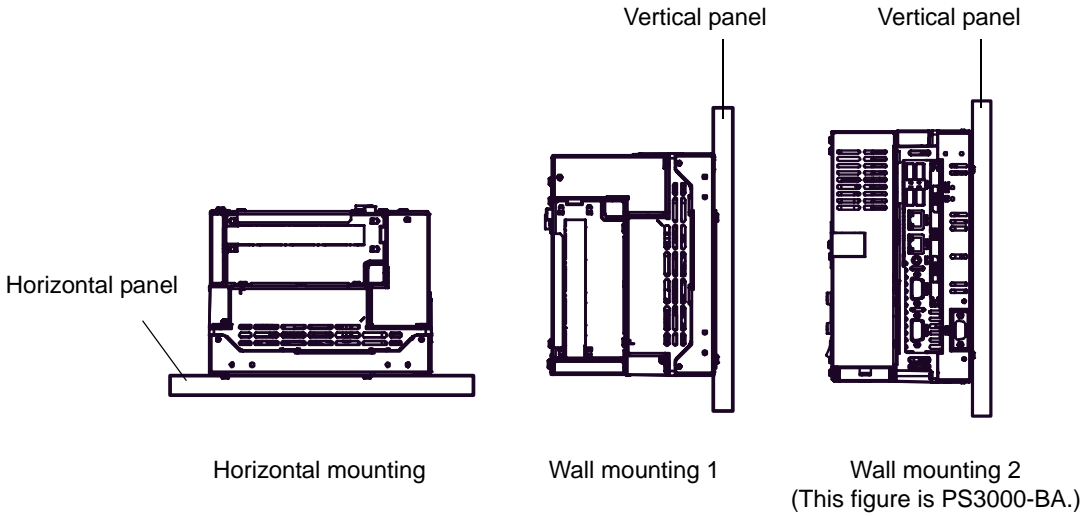

- For easier maintenance, operation, and improved ventilation, be sure to install the PS-B at least 50mm [1.97in.] away from adjacent structures and other equipment. 120mm [4.72in.] space (minimum) is necessary at the front for cable curve.

Unit: mm[in.]

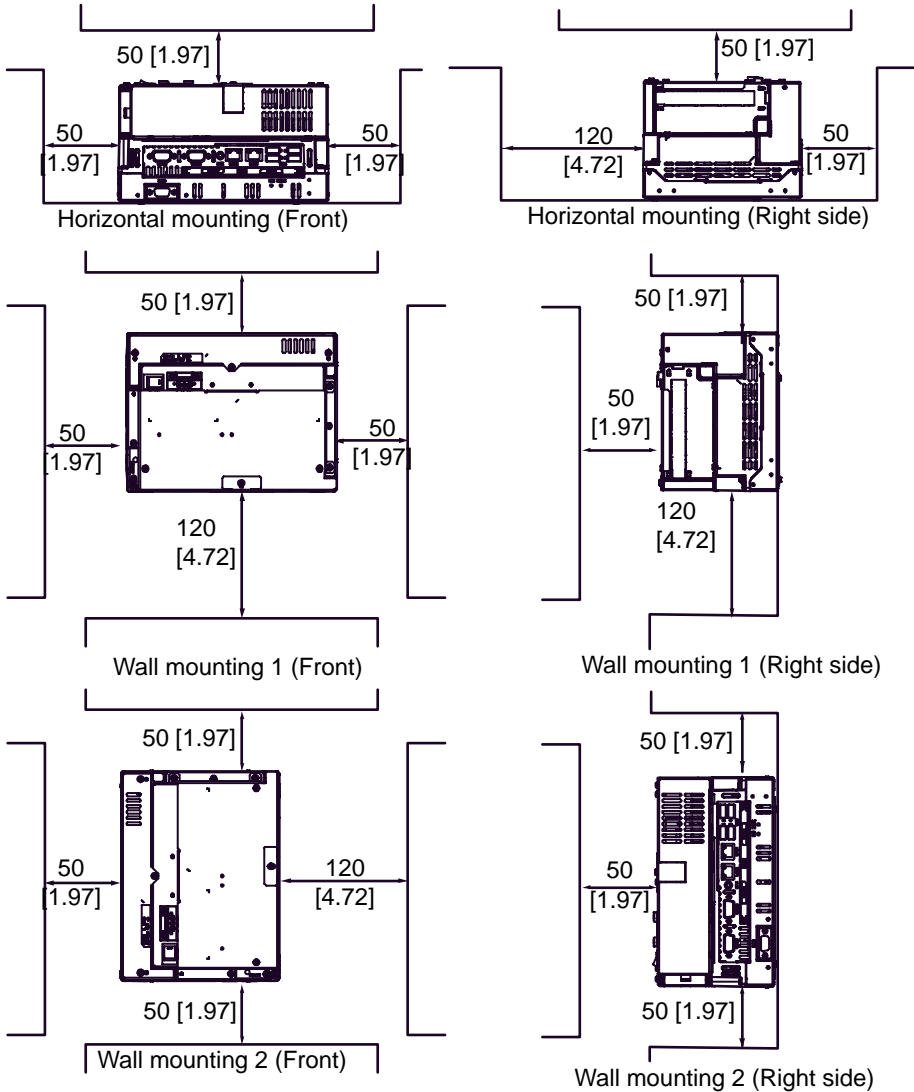

(This figure is PS3000-BA.)

- Be sure that the surrounding air temperature and the ambient humidity are within their specified ranges. Check the surrounding air temperature 30mm [1.18in.] away from the main unit.

Unit: mm[in.]

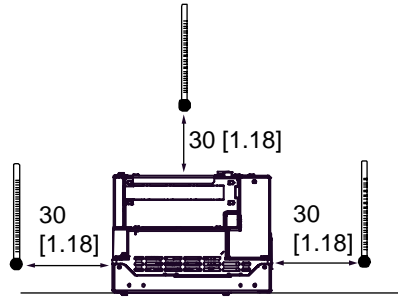
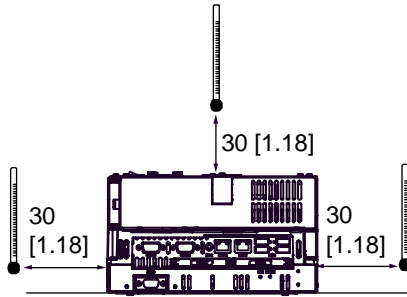

(This figure is PS3000-BA.)

- Be sure that heat from surrounding equipment does not cause the PS-B to exceed its standard operating temperature.

■ Creating Screw Holes

Create the correct sized openings required to install the PS-B, using the installation dimensions given.

SEE →

PS3000-BA

■ *Dimensions of the Screw Holes (page 2-18)*

PS3001-BD

■ *Dimensions of the Screw Holes (page 2-32)*

■ Installing the PS-B

- (1) Attach installation fasteners with the accompanying four M3 screws to the PS-B unit.

The torque should be 0.5 to 0.6 N•m.

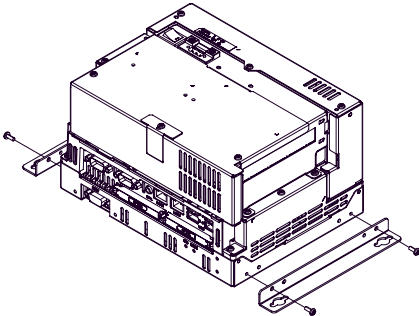

(This figure is PS3000-BA.)

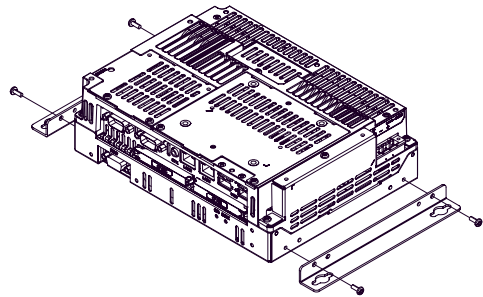

(This figure is PS3001-BD.)

- (2) Attach the PS-B unit to the board with M4 screws (not supplied): First, tighten the screws temporarily on the board; mount installation fasteners temporarily onto the screws; and then tighten the screws until the PS-B unit is securely fixed. The torque should be 1.0 to 1.2 N•m.

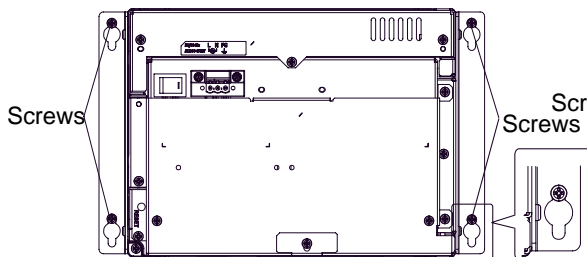

Horizontal mounting / Wall mounting 1
(PS3000-BA Top)

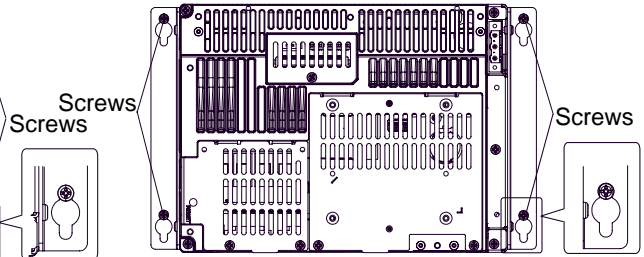

Horizontal mounting / Wall mounting 1
(PS3001-BD Top)

IMPORTANT

- Depending on the panel's material and design, the installation surface may need to be strengthened. If high levels of vibration are expected and the PS-B unit's installation surface (i.e. an operation panel's door, etc.) can move (i.e. open or close) due consideration should be given to the PS-B unit's weight.
- Determine the thickness of the panel in consideration of its material and strength as well as the environment in which the PS-B unit is used. The thickness must be 1.6mm [0.06in.] or more, considering the length of M4 screws.
- M4 screws are not included with the PS-B unit. Please provide them yourself.
- Tightening the screws with too much force can damage the PS-B unit.
- Be sure to insert installation fasteners in the recessed portion of an installation fasteners hole. If the fasteners are not correctly attached, the PS-B unit may shift or fall out of the panel.

3.2 Peripheral Devices Installation

A wide variety of optional units, DIM module, CF Cards, manufactured by Pro-face and commercial Expansion boards (PCI bus compatible board) can be used with the PS-B.

When installing the optional units, refer to each unit's "Installation Guide".

⚠ WARNING

- ⊘ Be sure to confirm that power is not supplied to the PS-B unit before installing or removing any optional units, DIM module, CF Cards, or Expansion boards (PCI boards). Failure to do so can result in an electric shock.

IMPORTANT

- If the PS-B unit is in the Soft OFF Status, power is supplied to a part of circuits even when no screen connected to the PS-B unit is displayed. Be sure to confirm that a power cable is not connected before installing or removing peripheral equipment.
- Use a screwdriver to loosen or tighten the screws. Be sure not to tighten screws too tightly, since it may damage the unit.
- When removing or replacing screws, be careful that they do not fall inside the PS-B unit's chassis.
- When installing the PS-B unit, or when attaching an optional item to the PS-B unit, do not hold the PS-B unit's rear-face fan cover while performing the work. Doing so may damage the fan cover or cause the cover to fall off.

3.2.1 Main Memory Installation

- (1) For PS3000-BA, unscrew the screws (2) from the Expansion Board Cover in advance, and remove the cover. For PS3001-BD users, please go to Step (2).

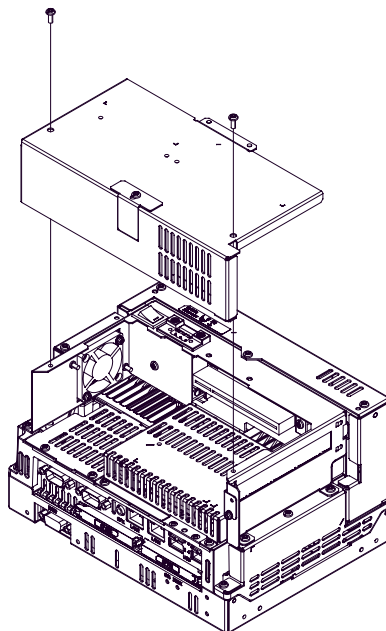

(Only for PS3000-BA.)

- (2) Unscrew the screws (2) from the Memory Slot Cover, and remove the cover.

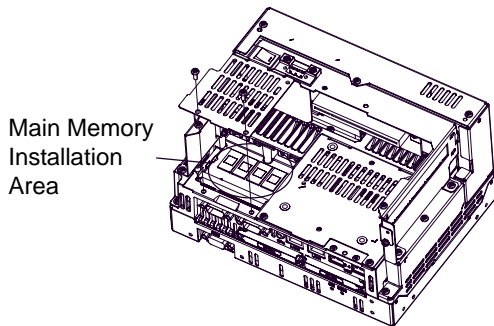

(This figure is PS3000-BA.)

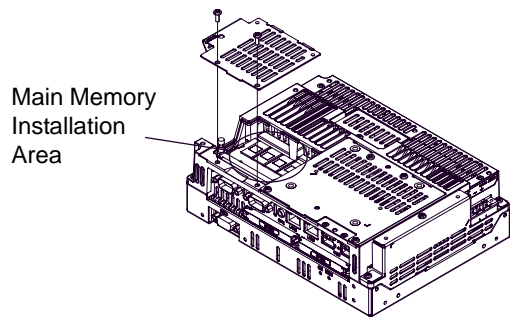

(This figure is PS3001-BD.)

- (3) Angle the main memory module down slightly, and push it in until the connector pins mate with the module's pins. Then, lower the module until it is horizontal and insert it completely into the connector. This connector is shown in (2).

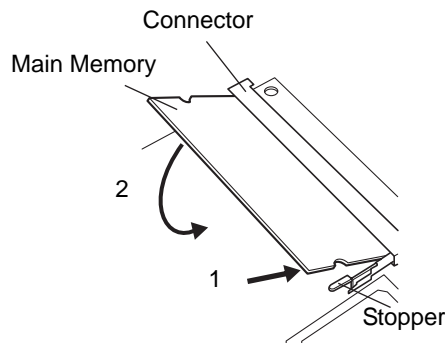

- (4) Push in the main memory module until the stopper snaps into place.
- (5) Replace the Memory Slot Cover and reattach two (2) attachment screws.
- The torque should be 0.5 to 0.6N•m.
- (6) For PS3000-BA, replace the Expansion Board Cover and reattach two (2) attachment screws lastly. The torque should be 0.5 to 0.6N•m.

3.2.2 Expansion Board (PCI) Installation

NOTE

- The Expansion Board (PCI) is corresponding to PS3000-BA units.

A PCI board, which is sold on the market, can be installed on PS3000-BA.

NOTE

- The maximum size allowed for a PCI board is 106.68mm [4.2in.] x 174.63mm [6.88in.] .

- (1) Turn OFF the power switch of the PS-B and remove the power cable. Place the PS-B on a flat, level surface facing the top side upwards.

- (2) Unscrew a screw of the expansion board support and remove the expansion board support.

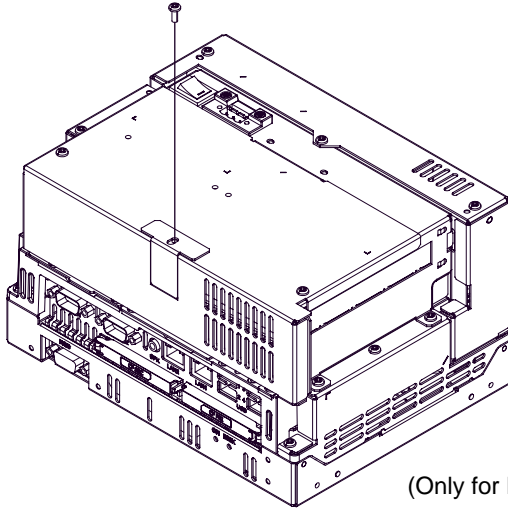

(Only for PS3000-BA.)

- (3) Unscrew the screws (2) from the Expansion Board Cover, and remove the cover.

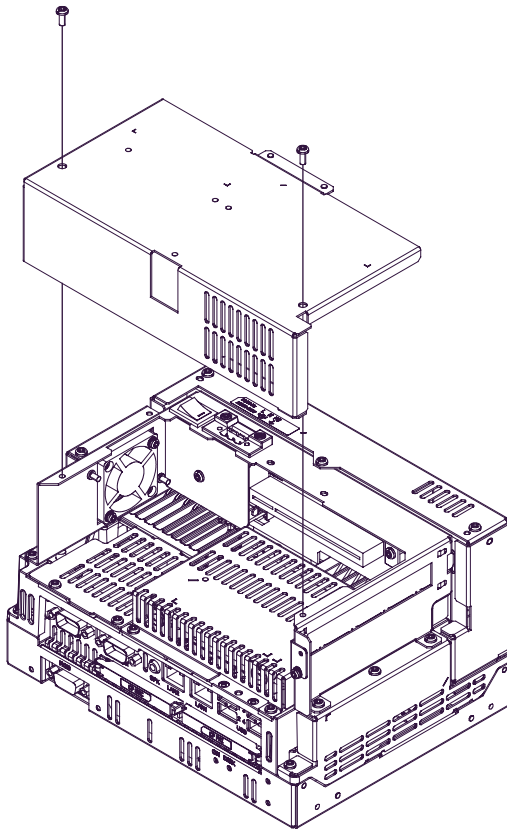

(This figure is PS3000-BA built-in HDD unit.)

- (4) Remove the blank panel's screw, and detach the blank panel.

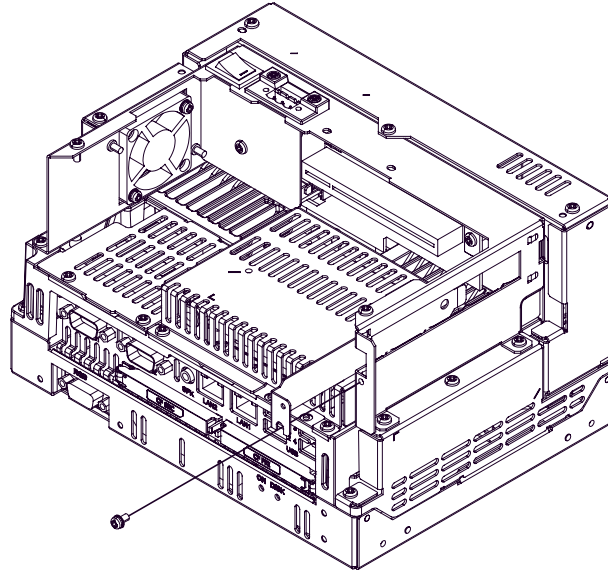

- (5) Insert the expansion board (commercial-type PCI) into the expansion board connector, and secure it in place using the filler panel's screw. The necessary torque is $0.5\text{N}\cdot\text{m}$ to $0.6\text{N}\cdot\text{m}$.

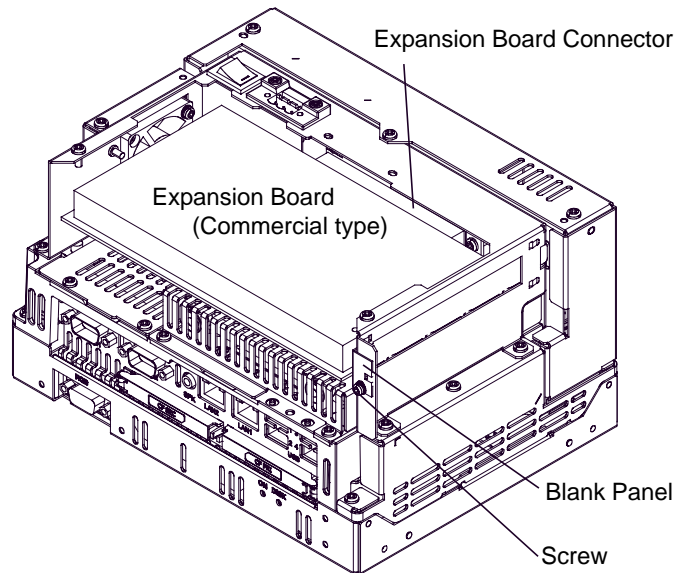

- (6) Place back both of the expansion board cover and expansion board support. The torque required to tighten each of the screws is 0.5 to $0.6\text{N}\cdot\text{m}$.

3.2.3 HDD Unit Installation

⚠ WARNING

! Shock Danger! Be sure to unplug the PS-B unit from its power supply prior to installing the HDD unit.

IMPORTANT

- Since the HDD unit is a precision instrument that has a low resistance to shocks, be sure it is neither hit by nor pressed strongly against another object when installing it.
- Even when the PS-B unit's screen display disappears, the power might be distributed inside (such as the "Standby" status etc.). Be sure to confirm that the power supply switch on the top side of the PS-B unit is OFF or that the power is not supplied to the PS-B unit.
- The HDD unit can not be attached to the PS3001-BD.

(1) Unscrew the screws (2) from the Expansion Board Cover, and remove the cover.

When replacing the cover, the torque required for these screws is 0.5 to 0.6N•m.

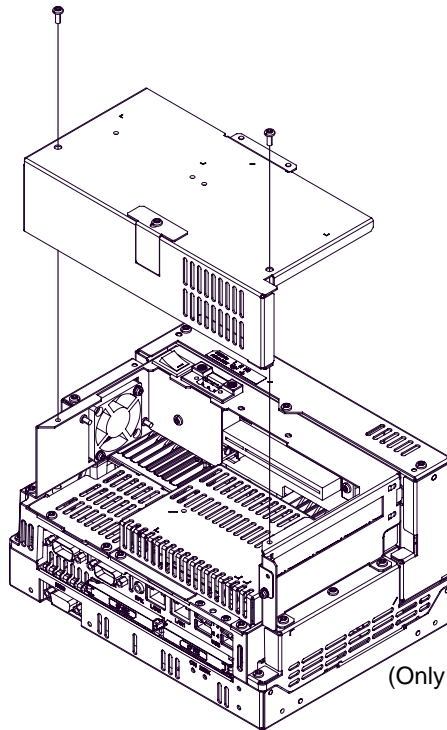

(Only for PS3000-BA.)

- (2) Unscrew the screws (2) of the HDD cover and remove the HDD cover.

When replacing the cover, the torque required for these screws is 0.5 to 0.6N•m.

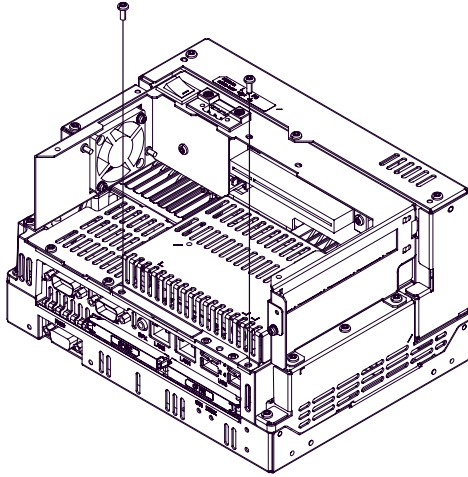

- (3) Unscrew the screws (4) of the HDD unit, remove the cable connector from IDE I/F while lifting up the HDD unit, and remove it. To replace the HDD unit, connect the cable connector to IDE I/F securely and fix the HDD unit with the screws (4). The torque required for these screws is 0.5 to 0.6N•m.

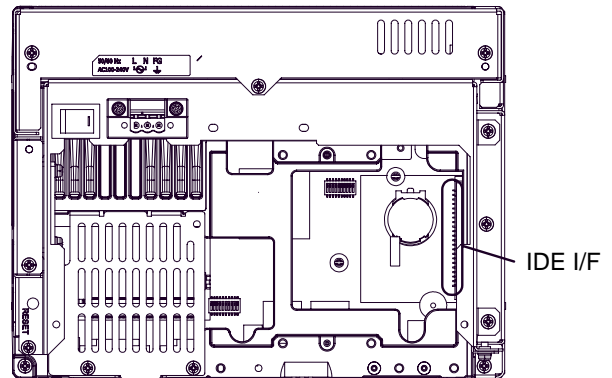
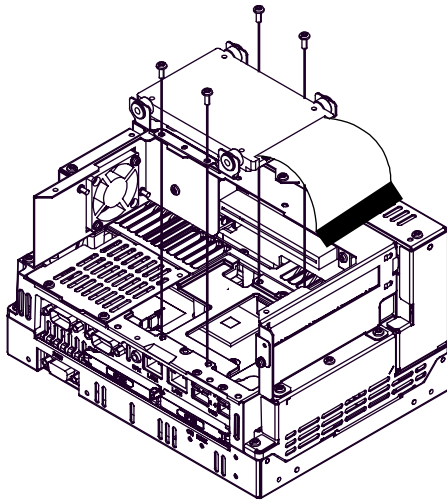

PS3000-BA Inside of the top

3.2.4 CF Card Insertion/Removal

⚠ CAUTION

- ⊘ Prior to inserting or removing a CF Card, be sure to confirm that the PS-B unit is turned OFF. If you do not, CF Card internal data may be damaged or lost or the OS may stop.
- ⊘ While a CF Card is being accessed (IDE Access Lamp: Lit in green), NEVER turn OFF or reset the PS-B, or insert or remove the CF Card. If you do not, CF Card internal data may be damaged or lost.
- ❗ Prior to inserting a CF Card, familiarize yourself with the CF Card's front and rear face orientation, as well as the CF Card connector's position. If the CF Card is not correctly positioned when it is inserted into the Multi Unit, the CF Card's internal data, CF Card and the PS-B unit may be damaged or broken.
- ❗ Be sure to use only CF Cards manufactured by the Pro-face. The CF Card's internal data may be damaged when using another manufacturer's CF Card.
- ❗ Once PS-B data is lost, it cannot be recovered. Since accidental data loss can occur at any time, be sure to back up all PS-B screen and CF Card data regularly.
- ⊘ Be sure to follow the instructions given below to prevent the CF Card's internal data from being destroyed or a CF Card malfunction from occurring:
 - DO NOT bend the CF Card.
 - DO NOT drop or strike the CF Card against another object.
 - Keep the CF Card dry.
 - DO NOT touch the CF Card connectors.
 - DO NOT disassemble or modify the CF Card.

■ When inserting the CF Card

- (1) Remove the CF Card cover.

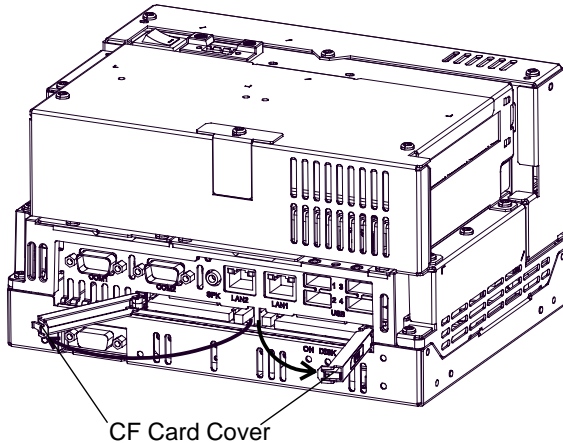

(This figure is PS3000-BA.)

- (2) Insert the CF Card firmly into the CF Card slot, and check that the eject button pops out.

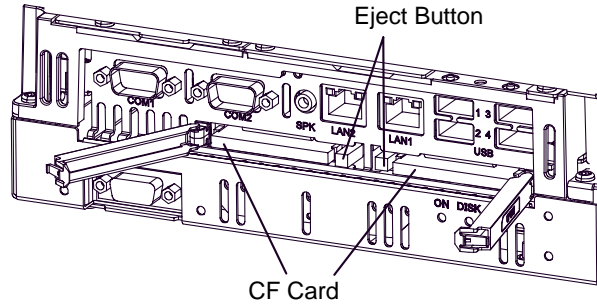

■ Removing the CF Card

- (3) Press the eject button in fully to remove the CF Card from the CF Card slot.
- (4) After inserting/removing the CF Card, be sure to replace the CF Card cover and secure it in place using the attachment screw.

■ Backup of CF Card

The CF Card has a data overwrite limit of approximately 100,000 times. Therefore, be sure to back up all CF Card data regularly to another storage media. (100,000 times assumes the overwriting of 500KB of data in DOS format.)

3.2.5 USB Cable Clamp Attachment/Removal

This clamp is used to prevent the USB cable connected to the USB Host Interface on the front of the PS-B unit from being unplugged due to vibration or other causes.

■ Attachment

- (1) Place the PS-B unit face-down on a flat surface as shown below. Your PS-B unit has four USB connectors.

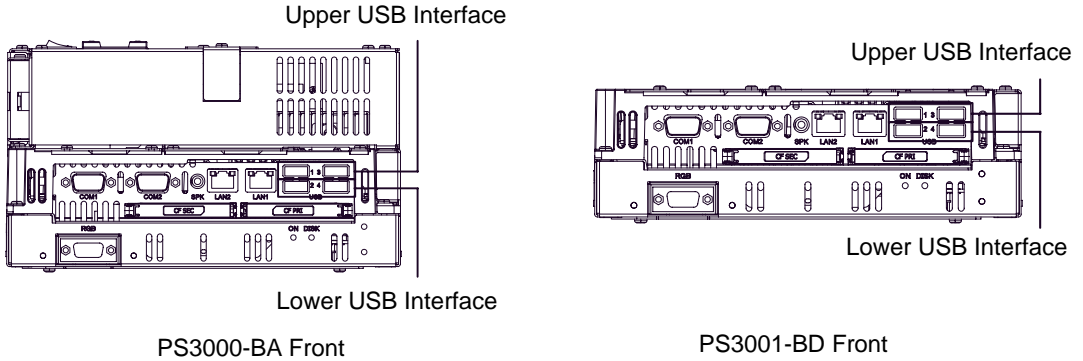

NOTE

- When using two or more USB ports, be sure to first connect one USB cable to the upper USB connector, and then connect the second USB cable to the lower USB connector.
- When using only one of the USB ports, be sure to use the upper USB connector. This allows you to securely clamp the USB cable in the cable clamp.

- (2) For PS3000-BA, unscrew the screws (2) from the Expansion Board Cover, and open the cover.

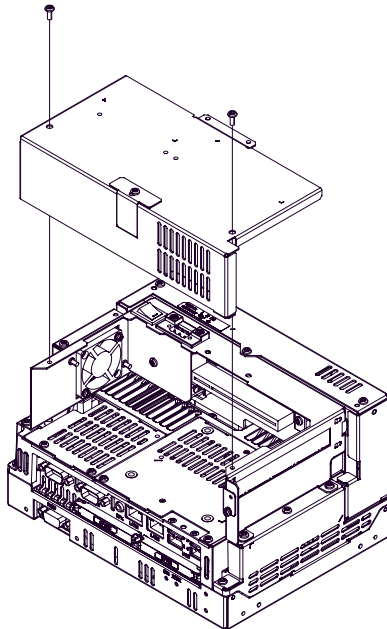

(This figure is PS3000-BA.)

- (3) Fix the USB holder with a screw. The torque required for this screw is 0.5 to 0.6N•m. Next, as shown, insert the USB Cable Clamp's band through the bridge. Pass the USB cables through the Cable Clamp's band and securely tighten the clamp band around the cables.

NOTE

- Be sure the clamp is securely holding the USB cable's plug and collar.
- Be sure the clamp is positioned as shown below, with the clamp pointing upwards - not to the side. This is to keep the clamp from interfering with nearby connectors and their cables.

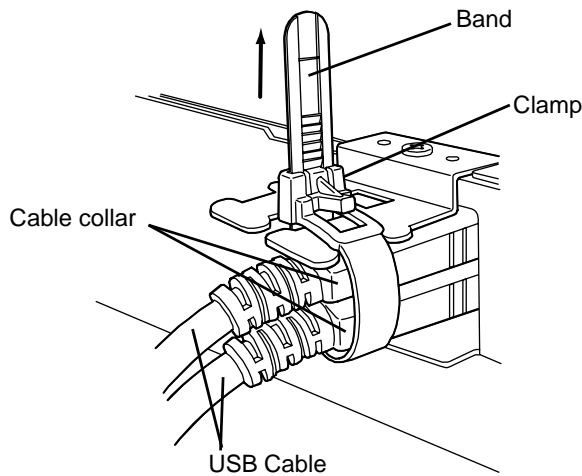

- (4) For PS3000-BA, replace the Expansion Board Cover and reattach two (2) attachment screws. The torque required for these screws is 0.5 to 0.6N•m.

■ Removing the USB Cable Clamp

- (1) To remove the clamp from the USB cables, push down on the clamp strap's clip to release it while pulling up on the clamp.

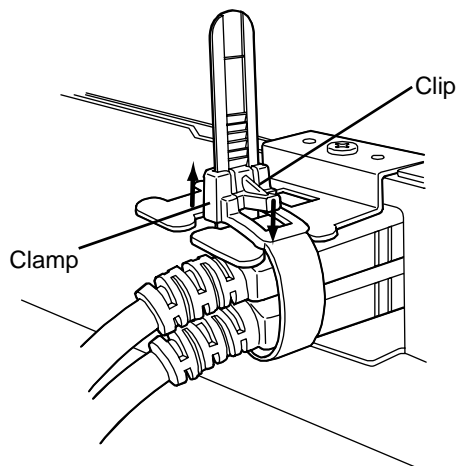





3.3 Wiring Precautions

This section describes the procedures and precautions for wiring power cords.

3.3.1 Connecting the Power Cord

 **WARNING**

-  Be sure to confirm that power is not being supplied to the PS-B unit before wiring . Failure to do so can result in an electric shock.
-  Supplying a power voltage other than that specified will damage the power source and the PS-B unit.
-  Since there is no power switch on the DC type PS-B unit, be sure to attach a breaker-type switch to its power cord.
-  When the FG terminal is connected, be sure the wire is grounded.

IMPORTANT

- When the FG terminal is connected, be sure the wire is grounded. Not grounding the PS-B unit will result in excess noise and vibration.
- The SG and FG terminals are connected internally in the PS-B unit.
When connecting the SG wire to another device, be sure that the design of the system/connection does not produce a shorting loop.

■ AC Connections

 **WARNING**

-  The PS-B units is designed to use AC100V to 240V input. Supplying a power voltage other than that specified will damage the power source and the PS-B unit.

Power Cord Specifications

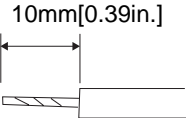
Power Cord Diameter	0.75 to 2.5mm ² (18 to 12 AWG)
Conductor Type	Simple or Stranded Wire ^{*1}
Conductor Length	

^{*1} If the Conductor's end (individual) wires are not twisted correctly, the end wires may either short against each other, or against an electrode.

IMPORTANT

- Use copper conductors only.

Wiring

When connecting the power cord, use the following items when performing wiring. (Items are made by Phoenix Contact.^{*1})

Recommended Driver	SZS 0.6x3.5 (1205053)
Recommended Pin Terminals	AI 0.75-10GY (3201288) AI 1-10RD (3200182) AI 1.5-10BK (3200195) AI 2.5-12BU (3200962)
Recommended Pin Terminal Crimp Tool	CRIMPFOX ZA3 (1201882)

NOTE

- Accompanying AC type power supply connector (plug) is CA7-ACCNL-01 from Pro-face or FKC2.5/3-STF-5.08 is manufactured by Phoenix Contact^{*1}.

^{*1} For details, please contact your local Phoenix Contact distributor.

Connecting the Power Cord

- (1) Confirm that the power is not supplied to the PS-B unit.
- (2) Unplug the power connector from the top of the PS-B unit.
- (3) Push the Opening button with a small and flat screw driver to open the desired pin hole.

(4) Insert each pin terminal into its each hole. Release the Opening button to clamp the pin in place.

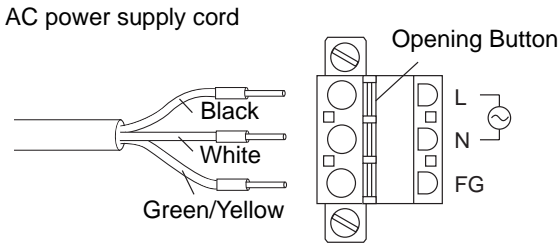

(5) After inserting all three pins, insert the Power Plug into the Power Connector at PS-B. Fix the plug with two (2) slot screws.

IMPORTANT

- Confirm that all wires are connected correctly.
- The torque required to tighten these screws is 0.5 to 0.6N•m.
- To prevent the possibility of a terminal short, use a pin terminal that has an insulating sleeve.

■ DC Connections

Power Cord Specifications

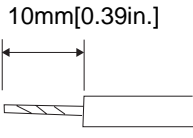
Power Cord Diameter	0.75 to 2.5mm ² (18 to 12 AWG)
Conductor Type	Simple or Stranded Wire* ¹
Conductor Length	10mm[0.39in.] 

*1 If the Conductor's end (individual) wires are not twisted correctly, the end wires may either short against each other, or against an electrode.

IMPORTANT

- Use copper conductors only.

Wiring

When connecting the power cord, use the following items when performing wiring. (Items are made by Phoenix Contact. *1)

Recommended Driver	SZS 0.6x3.5 (1205053)
Recommended Pin Terminals	AI 0.75-10GY (3201288) AI 1-10RD (3200182) AI 1.5-10BK (3200195) AI 2.5-12BU (3200962)
Recommended Pin Terminal Crimp Tool	CRIMPFOX ZA3 (1201882)

NOTE

- The power supply connector (plug) is CA7-DCCNL-01 from Pro-face or GFKC2,5/3-STF-7,62 (made by Phoenix Contact *1).

*1 For details, please contact your local Phoenix Contact distributor.

Connecting the Power Cord

- Confirm that the power is not supplied to the PS-B unit.
- Unplug the power connector from the top of the PS-B unit.
- Push the Opening button with a small and flat screw driver to open the desired pin hole.
- Insert each pin terminal into its each hole. Release the Opening button to clamp the pin in place.

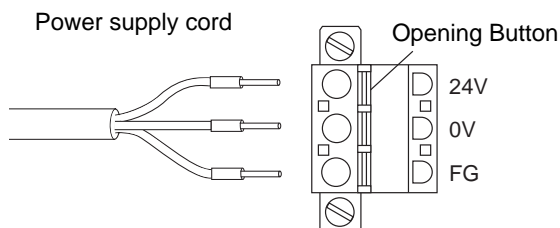

- After inserting all three pins, insert the Power Plug into the Power Connector at PS-B. Fix the plug with two (2) slot screws.

IMPORTANT

- The torque required to tighten these screws is 0.5 to 0.6N•m.
- To prevent the possibility of a terminal short, use a pin terminal that has an insulating sleeve.

3.3.2 Connecting the Power Supply

This section describes the precautions for supplying a power voltage.

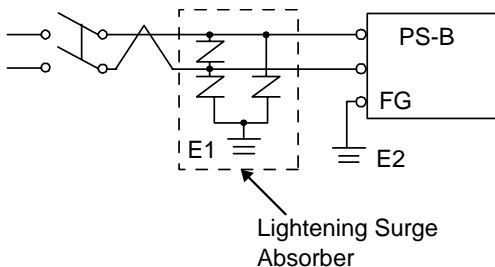
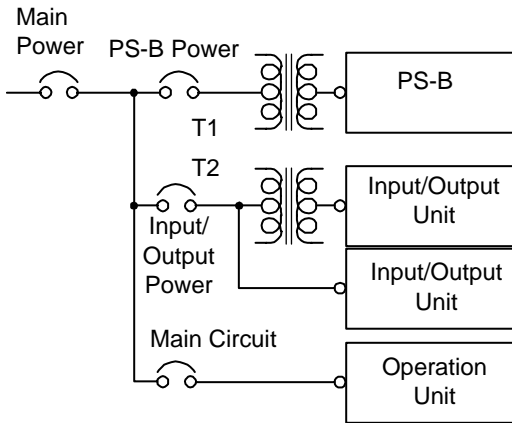
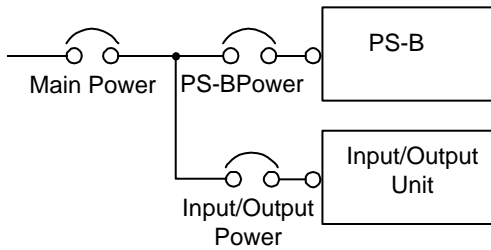
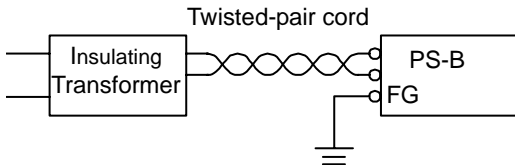
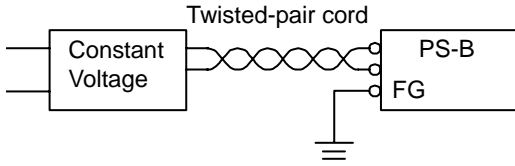

- If the supplied voltage exceeds the PS-B unit's range, connect a constant voltage transformer.

SEE → Chapter 2 "Specifications" (page 2-1)

- For between the line and ground, select a power supply that is low in noise. If there is an excess amount of noise, connect an insulating transformer.

IMPORTANT

- Use constant voltage and insulating transformers with capacities exceeding Power Consumption value.

- When supplying power to the PS-B unit, be sure to separate the input/output and power lines, as shown.
- To increase the noise resistance quality of the power cord, simply twist each power wire before attaching the Ring Terminal.
- The power supply cable must not be bundled or positioned close to main circuit lines (high voltage, high current), or input/output signal lines.
- Connect a lightning surge absorber, as shown in the diagram, to deal with power surges.
- To avoid excess noise, make the power cord as short as possible.
- 24V DC input unit is must be used with a Class 2 power supply.
- The temperature rating of field installed conductors: 75°C only.

IMPORTANT

- Be sure to ground the surge absorber (E1) separately from the PS-B unit (E2).
- Select a surge absorber that has a maximum circuit voltage greater than that of the peak voltage of the power supply.

3.3.3 Grounding

This section describes the precautions for grounding the PS-B unit.

⚠ CAUTION

❗ Do not use common grounding, since it can lead to an accident or machine breakdown.

(a) Exclusive Grounding (BEST)

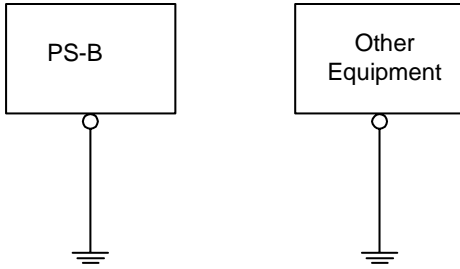

(b) Exclusive Grounding (OK)

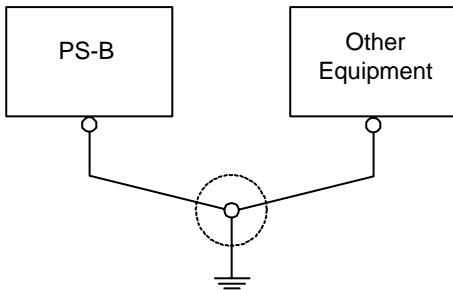

(c) Common Grounding (Not OK)

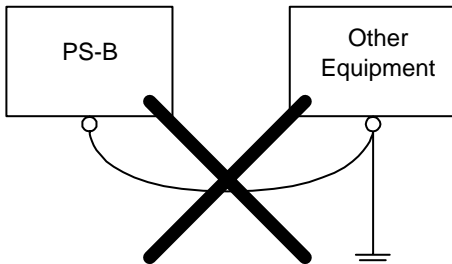

- When supplying power to the PS-B unit, be sure to separate the input/output and power lines, as shown. [diagram (a)]

IMPORTANT

- Check that the grounding resistance is 100Ω or less.
- FG and SG terminals are internally connected in the PS-B. When connecting an external device to the PS-B using the SG terminal, be sure to check that no short-circuit loop is created when you setup the system.
- The grounding wire should have a cross sectional area greater than 2mm^2 . Create the grounding point as close to the PS-B unit as possible, and make the wire as short, as possible. When using a long grounding wire, replace the thin wire with a thicker wire, and place it in a duct.

- If exclusive grounding is not possible, use a common grounding point. [diagram (b)] A grounding or equivalent should be used for the grounding point.

NOTE

- If the equipment does not function properly when grounded, disconnect the ground wire from the FG terminal.

3.3.4 I/O Signal Line Placement

- Input and output signal lines must be separated from the power control cables for operating circuits.
- If this is not possible, use a shielded cable and ground the edge of the shield.

4

Maintenance

1. Cleaning the Fan Filter
2. Periodic Check Points
3. Replacing the Internal Battery

This chapter explains cautions and inspection criteria that will ensure trouble-free use of the PS-B.

4.1 Cleaning the Fan Filter

Since excessive dirt and dust in the filter of the PS3000-BA's electric fan can potentially affect the performance of the unit, regular inspection and cleaning of the filter is strongly recommended.

IMPORTANT

- The PS-B's fan has a lifetime. (Expected life: approx. 5 years at the ambient temperature 25°C)

This lifetime may be shortened depending on the usage environment.

When the fan needs to be replaced, please contact your local PS-B distributor immediately.

NOTE

- The fan rotation speed can be monitored on the System Monitor.



PS-3450A/PS-3451A/PS-3000BA/PS-3001BD Reference Manual

- (1) Turn OFF the power switch of the PS-B and remove the power cable. Place the PS-B on a flat, level surface facing the top side upwards.
- (2) Unscrew the screw (1) as shown below, and remove the fan unit. Remove the filter between the fan cover and the fan.

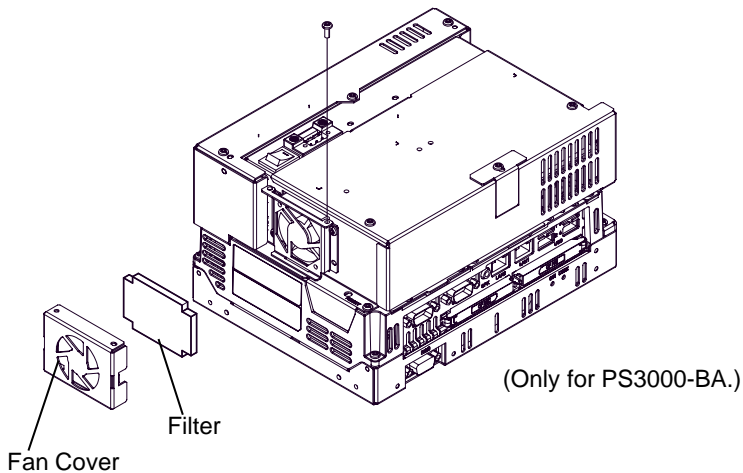

- (3) Clean the filter completely.

If stubborn dirt or stains are present, wash the filter with a neutral detergent.

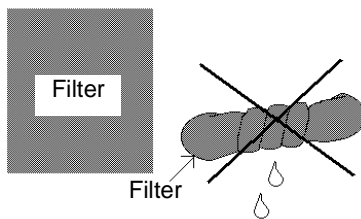

IMPORTANT

- Do not wring the filter to dry it.
- When drying the filter, dry it without exposing it to direct sunlight.
- Allow it to air dry completely before reattaching to the PS-B.

- (4) After reattaching the filter to the filter cover, reattach the fan cover with its cover attachment screw (1).
The torque should be 0.5 to 0.6N•m.

IMPORTANT

- Be sure the fan cover is securely attached to the PS-B unit. This is to ensure the fan cover does not fall off while the PS-B unit is operating.

4.2 Periodic Check Points

To keep your PS-B unit in its best condition, please inspect the following points periodically.

■ PS-B Operation Environment

- Is the operating temperature within the allowable range?

PS3000-BA: 0°C to 50°C (without HDD) 5°C to 50°C (with HDD)

PS3001-BD: 0°C to 50°C

- Is the operating humidity within the specified range?

PS3000-BA: 10 to 90%RH (Not condensing, wet bulb temperature: 39°C or less. Wet bulb temperature with HDD: 29°C or less.)

PS3001-BD: 10 to 90%RH (Not condensing, wet bulb temperature: 39°C or less.)

- Is the operating atmosphere free of corrosive gasses?

When using the PS-B unit inside an enclosure, the enclosure's atmosphere is the ambient environment.

■ Electrical Specifications

- Is the input voltage appropriate?

AC type: AC85 to 265V, 50/60Hz

DC type: DC19.2 to 28.8V

■ Related Items

- Are all power cords and cables connected properly? Have any become loose?

- Are all mounting brackets holding the unit securely?

4.3 Replacing the Internal Battery

The PS-B unit has an internal battery for backup of internal clock data.

Compatible Battery	Service Life
Lithium Battery CR2032 (Hitachi Maxell, Ltd.)	5 years

IMPORTANT

- The expected battery service life is 5 years, however the battery may die before then. It is strongly recommended that you replace the battery regularly.
- When the battery is replaced, a part of the BIOS settings are initialized. Configure the BIOS settings again after replacing the battery.

⚠ CAUTION

- ⚠ There is a danger of explosion if the PS-B unit's battery is incorrectly replaced. This battery should be replaced with equivalent type recommended by Pro-face.
- ⚠ Prior to replacing the battery, be sure to turn OFF the PS-B unit's power.
- ⚠ Be careful not to cause a short circuit.
- ⊘ Do NOT touch any internal parts except the battery and the battery holder.
- ⚠ During the replacement, be extremely careful not to drop the battery onto the PC board inside the PS-B unit. This may cause product failure.
- ⚠ Dispose of used batteries according to the battery manufacturer's instructions.

■ Battery Replacement Procedure

The battery is on the PC board inside the PS-B unit. Refer to the following for how to open the PS-B unit.

PS3000-BA: “2.1.3Interface Specifications ◆ Switches (page 2-10)”

PS3001-BD: “2.2.3Interface Specifications ◆ Switches (page 2-25)”

- (1) Be sure to confirm that power is not supplied to the PS-B unit and open the unit.

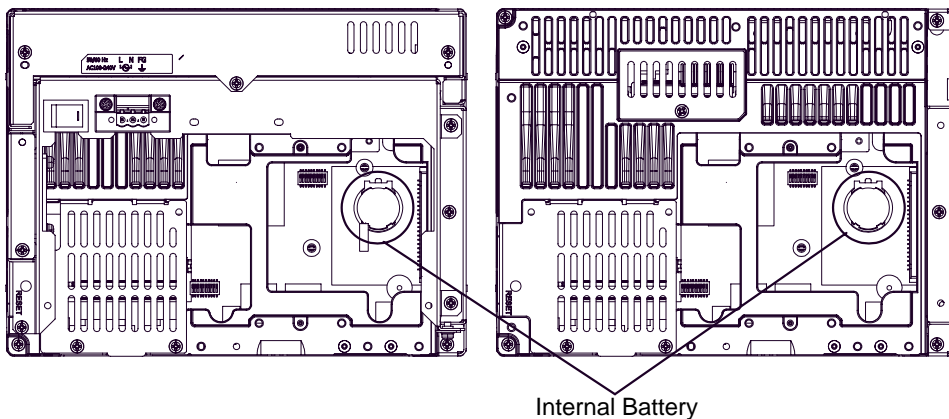

PS3000-BA Internal View

PS3001-BD Internal View

- (2) Insert a tool having a flat tip such as insulated slot-head screwdriver into the groove between the battery and battery holder as shown below. Then move the battery while lifting its bottom to remove it from the holder.

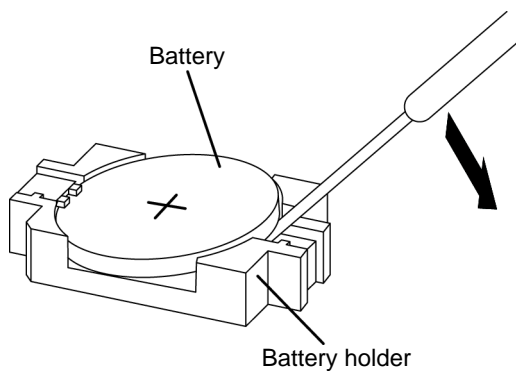

- (3) Insert the new battery. Insert the battery in the side of the clip of the battery holder first with the plus pole (+) facing upward. Push the battery from above until you hear the click to fit it in the battery holder.

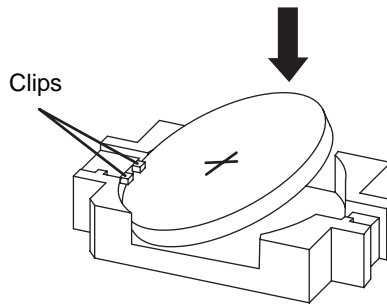

IMPORTANT

- Be sure the battery's plus(+) and minus(-) sides are correctly oriented.

- (4) Return the PS-B unit to the original condition.

IMPORTANT

- Be sure to adjust the time of the internal clock after replacing the battery.