



WARNINGS

- When inserting the PS-3701A(Eden™ ESP6000 - 667MHz Model) (hereafter referred to as the "PS-A")'s power cord into the PS-A's Power Plug, check first that the PS-A's power supply is completely turned OFF, via a breaker, or similar unit.
- Before either plugging in or unplugging interface connector, be sure to turn the PS-A's power OFF.
- Whenever changing the Backlight, to prevent electric shocks and burns, be sure to turn OFF the PS-A's power and wear protective gloves.
- After the PS-A's backlight burns out, unlike the PS-A's "Standby Mode", the touch panel is still active. If the operator fails to notice that the backlight is burned out and touches the panel, a potentially dangerous machine operation error can occur.
If your PS-A's backlight suddenly turns OFF, use the following steps to determine if the backlight is actually burned out.
 - 1) If your PS-A is not set to "Standby Mode" and the screen has gone blank, your backlight is burned out.
 - 2) Or, if your PS-A is set to Standby Mode, but touching the screen does not cause the display to reappear, your backlight is burned out.
- Do not open or remodel the PS-A unit, since it may lead to a fire or electric shock.
- Do not use power beyond the PS-A unit's specified voltage range. Doing so may cause a fire or electric shock.
- Do not use the PS-A unit in an environment where flammable gases are present, since operating the PS-A unit may cause an explosion.
- The PS-A uses a lithium battery for backing up its internal clock data. If the battery is incorrectly replaced (i.e. its + and - sides are reversed), the battery may explode. When changing the battery, please contact your local PS-A distributor.
- Do not use the PS-A unit as a warning device for critical alarms that can cause serious operator injury, machine damage or production stoppage. Critical alarm indicators and their control/activator units must be designed using stand-alone hardware and/or mechanical interlocks.
- To prevent operator injury or machine damage, be sure to design your machine operation system so that the machine will not malfunction due to a communication fault between the PS-A and its host controller.
- Do not use PS-A touch panel switches in life-related or important disaster prevention situations. For safety related switches, such as an emergency switch, be sure to use a separate mechanical switch.
- The PS-A is not appropriate for use with aircraft control devices, aerospace equipment, central trunk data transmission (communication) devices, nuclear power control devices, or medical life support equipment, due to these devices inherent requirements of extremely high levels of safety and reliability.
- When using the PS-A with transportation vehicles (trains, cars and ships), disaster and crime prevention devices, various types of safety equipment, non-life support related medical devices, etc. redundant and/or failsafe system designs should be used to ensure the proper degree of reliability and safety.

To prevent this unit from malfunctioning :

- In order to extend the lifetime of the hard disk, Pro-face recommends you set the Windows [Control panel]-[Power Management option]-[Turn off hard disks] selection to turn the hard disk off when the unit is not being operated. A setting of 5 minutes is recommended.
- Do not strike the PS-A's touch panel with a hard or heavy object, or press on the touch panel with excessive force, since it may damage the display.
- Do not install the PS-A where the temperature will exceed its specified range.
- Be sure that water, liquids or metal particles do not enter the PS-A, since it may cause a malfunction or a short circuit.
- Avoid installing the PS-A where sudden, large changes in temperature may occur. These changes may cause condensation to form inside the unit, possibly causing a malfunction.
- To prevent excessive heat from building up inside the PS-A, do not install it where its ventilation holes may be blocked. Also, do not install or store the PS-A near high temperature equipment.
- Do not install or store the PS-A in direct sunlight or where high levels of dust exist.
- Since the PS-A is a precision instrument, do not install or store it where either strong shocks or excessive vibration may occur.
- Do not install or store the PS-A in an area containing chemicals or chemical fumes.
- Do not use paint thinner or organic solvents to clean the PS-A's case or screen.
- Due to the danger of unforeseeable accidents, back up all PS-A data regularly.
- After turning this unit OFF, be sure to wait a few seconds before turning it ON again. If the unit is started too soon, it may not start up correctly.

UL/CSA Application Notes

The PS3701A-T41-DU-E66 unit is a UL/CSA listed product (UL File No. E220851). Please pay special attention to the following instructions when applying for UL/CSA approval for machinery which includes any of these PS-A unit.

The PS-A conforms as a component to the following standards:

■ **UL508** Industrial Control Equipment

■ **CAN Std C22.2 No. 14-1995 CAN/CSA 22.2 No.60950**

PS3701A-T41-DU-E66 (UL Registration Model No.:3280022-01)

- Equipment with a PS-A unit mounted in it requires UL/CSA evaluation for the combination of the PS-A unit and equipment.
- The PS-A unit must be used as a built-in component of an end-use product.
- Use the PS-A indoors only.
- When connecting the PS-A unit's power cable, be sure to use a cable that is appropriate for the current and voltage used and that has conductive wires that are AWG18 or larger.
- When using the PS-A unit in an end-use product, be sure to install the PS-A unit's power cut-off switch where the operator can easily reach it.
- Danger of explosion if backup battery is incorrectly replaced. Should be replaced only with same or equivalent type recommended by the manufacturer. Dispose of used batteries according to the manufacturer's instructions.
- Be sure the unit the PS-A unit is built into uses a UL508 compatible structure.

CE Marking Notes

The PS3701A-T41-DU-E66 unit is CE marked, EMC compliant product.

<Complies with the following Standards>

• **Safety**

EN60950

• **EMI**

EN61000-6-4, EN55011 (Group 1, Class A)

• **EMS <EN61000-6-2/EN61131-2>**

EN61000-4-2, EN61000-4-3, EN61000-4-4, EN61000-4-5, EN61000-4-6,
EN61000-4-8, EN61000-4-12

• **FCC**

47CFR Part 15 Class A

If the following requirements are not met, the PS-A may fail to meet EN60950 standard requirements.

- The PS-A must be used as a built-in component of an end-use product.
- Use the PS-A indoors only.
- When connecting the PS-A unit's power cable, be sure to use a cable that is appropriate for the current and voltage used and that has conductive wires that are AWG18 or larger.
- When using the PS-A unit in an end-use product, be sure to install the PS-A unit's power cut-off switch where the operator can easily reach it.
- There is a danger of explosion if the backup battery is incorrectly replaced. This battery should be replaced only with same or equivalent type recommended by the manufacturer. Dispose of used batteries according to the manufacturer's instructions.
- Be sure the PS-A unit's enclosure is an EN60950 approved sheet steel structure.

Package Contents

The following items are included in the PS-A package. Before using the PS-A, please confirm that all items listed here are present.

- PS-A Unit (1)
(PS3701A-T41-DU-E66)

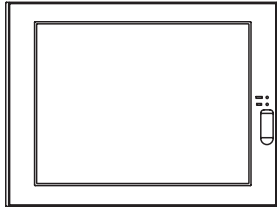

- Moisture Resistant Gasket (1)
<Attached to the PS-A Unit>



- Installation Fasteners (4/set x 2)

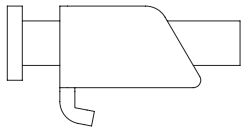

- Installation Guide (1)
<This Guide>



- USB Cable Clamp (1)

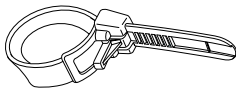

- CD-ROM [PS370XA-E666 User Manual & Driver CD] (1)



- Power Plug (1)

<Attached to the PS-A Unit>

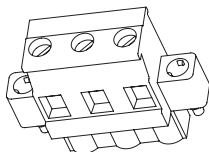

Be careful when installing the PS-A not to damage the built-in HDD.



- **The CD-ROM included in this package contains a User Manual, API Reference Manual, and PS-A Series Utility and Driver files. Please refer to PDF manuals.**

This unit has been carefully packed, with special attention to quality. However, should you find anything damaged or missing, please contact your local PS-A distributor immediately.

When you order a PS-A unit built to your specifications, that PS-A package should include each optional item's Installation Guide. Please use that guide to check the contents of each optional item's package.

About The Manual

The PS-A unit's CD-ROM contains the following PDF manual files.

- Compact Panel Computer PS-3701A (Eden™ ESP6000 - 667MHz Model) Series User Manual (psse6e.pdf)
- PS Series Type A (Eden™ ESP6000 - 667MHz Model) API Reference Manual (psae6ape.pdf)

Reading a PDF file requires installation of the Adobe Corporation's Acrobat® Reader.

■ Acrobat® Reader Installation:

To install the Acrobat® Reader software, follow the steps given below.

- 1) This software, in the form of a self-extracting file, is located in this CD-ROM in the folder titled [reader]. Use the Explorer software to find the file [Reader\Eng\ar505enu.exe], and double-click on the file icon to begin the Reader installation.
- 2) After installation begins, follow the instructions given.

■ Viewing the PDF manual:

To view the PDF manual contained in this CD-ROM, follow the steps given below.

- 1) Use the Explorer software to locate the file [Manual\Eng\psse6e.pdf or psae6ape.pdf] in the folder titled [Manual].
- 2) Double-click on the PDF file's icon. Acrobat® Reader will automatically start and the first page of the PDF manual will appear.

1 Part Names

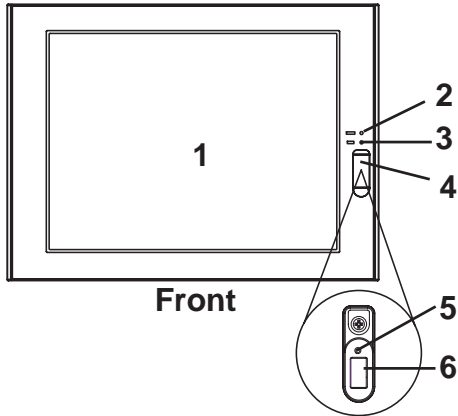

Front

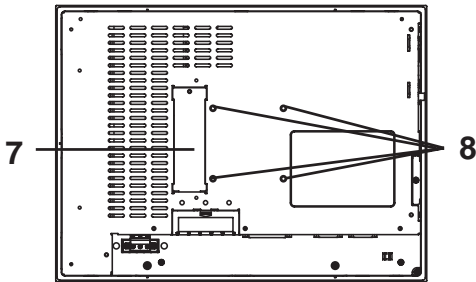

Rear

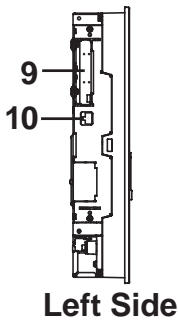

Left Side



Top



Bottom

1: Display/Touch Panel

2: Power LED Status Lamp (POWER)

LED	PS-A Status
Green	Normal Operation (Power On)
Orange	RAS Error Touch Panel Self Test Error
Orange/Red	Backlight is not functioning

3: IDE Access Lamp

LED	PS-A Status
Green	Currently using IDE I/F

4: Front Packing

5: Hardware Reset Switch (RESET)

6: USB Interface

1 Port

7: CD-ROM Driver Interface Cover

8: Arm Insertion Hole Location

VESA 75mm

9: PCMCIA Interface

2 Ports

10: Ethernet Interface (LAN)

10BASE-T/100BASE-TX Auto Changeover

11: Rear Cover

12: PS2 Keyboard Interface (KEYBOARD)

13: USB Interface (USB)

2 Ports

14: Serial Interface (COM2)

RS-232C/RS-422/RS-485 Changeover,
RI/+5V Changeover

15: Serial Interface (COM1)

RS-232C, RI/+5V Changeover

16: Speaker Output Interface (SPEAKER)

17: Printer Interface (LPT1)

18: CF Card Interface Cover

19: Power Plug



- When attaching peripheral units to the PS-A, be sure the PS-A's power cord is disconnected from the main power supply.
- To prevent an electrical shock, be sure to disconnect the PS-A's power cord from the power supply before connecting the cord's power terminals or any peripheral devices to the PS-A.

2 Dimensions

The PS-A unit dimensions are as follows.

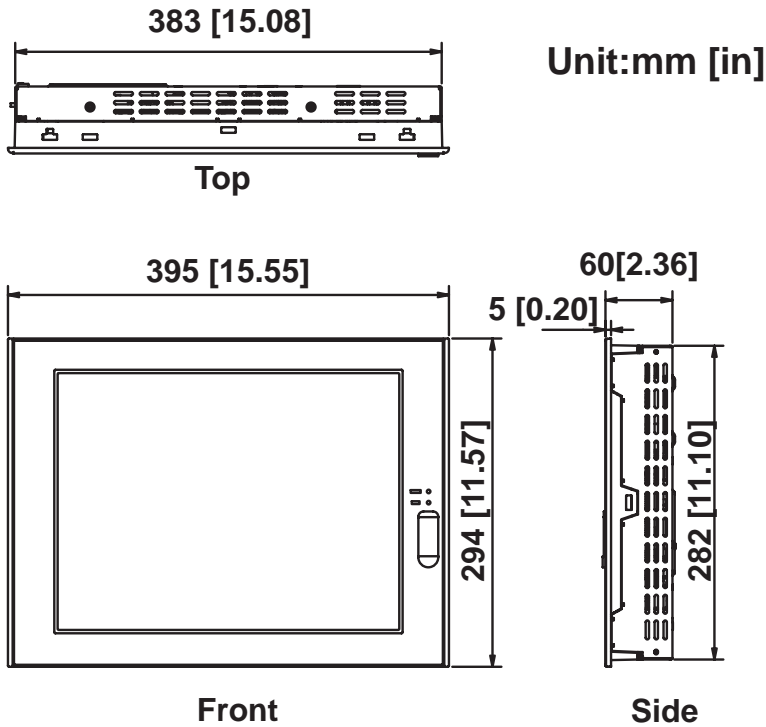

The following drawing shows the PS-A unit with installation fasteners.

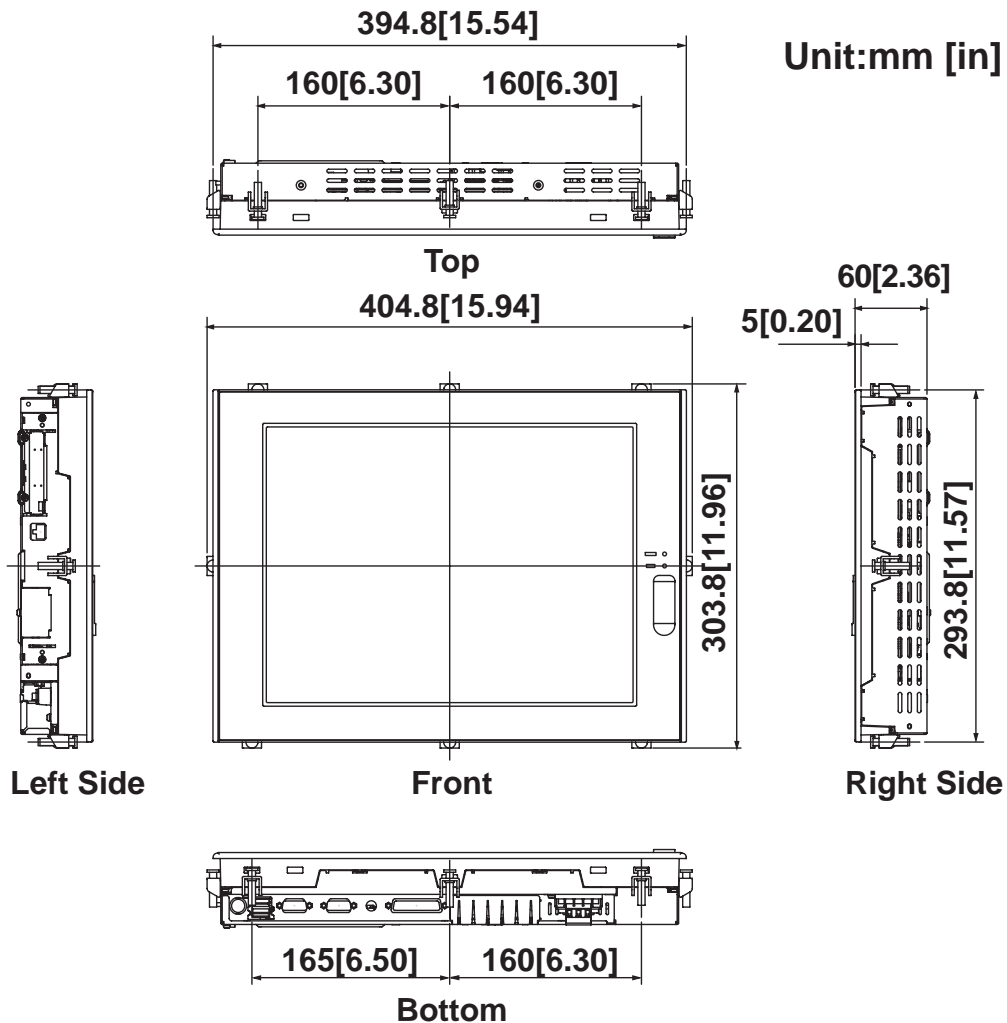

3 General Specifications

■ Electrical

Rated Voltage	DC24V
Voltage Supply Range	DC19.2V to DC28.8V
Power Consumption	90VA or less
Voltage Endurance	AC1000V 20mA for 1 minute (between charging and FG terminals)
Insulation Resistance	10MΩ or higher at DC500V (between charging and FG terminals)

■ Environmental

Ambient Operating Temperature	0 °C to +40 °C : without HDD +5 °C to +40 °C : with HDD
Storage Temperature	-10 °C to + 60 °C
Ambient Humidity	10%RH to 85%RH (Non condensing, wet bulb temperature : 29°C or less)
Storage Humidity	10%RH to 85%RH (Non condensing, wet bulb temperature : 29°C or less)
Air Purity (Dust)	Free of dust
Pollution Degree	Pollution Degree 2
Corrosive Gases	Free of corrosive gases
Vibration Resistance	19.6m/s ² at 10Hz to 25Hz : without HDD 4.9m/s ² at 10Hz to 25Hz : with HDD
Noise Immunity (via noise simulator)	Impulse Noise : 1500Vp-p (Line) Pulse Duration : 50ns, 500ns, 1μs Rise Time : 1ns
Noise Immunity (First transient burst noise)	Power Line : 2kV IEC 61000-4-4 COM Port : 1kV IEC 61000-4-4
Electrostatic Discharge Immunity	4kV IEC 61000-4-2



- *When using any of the PS-A's optional devices, be sure to check that device's specifications for any special conditions or cautions that may apply to its use.*
- *Be aware that not only does the Hard Disk have a fixed lifetime, but that accidents can always occur. Therefore, be sure to back up your Hard Disk's data regularly, or prepare another Hard Disk unit that can be used for backup.*



- *The Hard Disk lifetime given here may be reduced due to unforeseen environmental factors, however, generally speaking, the disk should last for 20,000 hours (of operation) or approximately 5 years, whichever comes first at an operating temperature of 20°C and 333 hours of operation per month. (HDD access frequency of 20% or less)*
- *Using the Hard Disk in an environment that is excessively hot and/or humid will shorten the disk's usage lifetime. A wet bulb temperature of 29°C or less is recommended. This is equivalent to the following data.*

Temperature	Humidity
at 35°C	no higher than 64%RH
at 40°C	no higher than 44%RH

- *When running the PS-A unit continuously, use Windows Control Panel Power Management Property to turn off the HDD motor when not performing any operation on the unit. It helps to lengthen the HDD's lifetime.*

■ Structural

Grounding	100Ω or less, or your country's applicable standard
Ratings ^{*1}	Equivalent to IP65f (JEM 1030) (When Not Using USB Port on Front face of installed unit) Design Type: Modular Installation method: Panel / VESA Arm
Cooling Method	Natural air cooling
Weight	Approx. 6.0kg (13.2lb)
Dimensions (W x H x D)	395 mm [15.55 in.] x 294 mm [11.57 in.] x 60 mm [2.36 in.]

**1 The front face of the PS-A unit, installed in a solid panel, has been tested using conditions equivalent to the standard shown in the specification. Even though the PS-A unit's level of resistance is equivalent to this standard, oils that should have no effect on the PS-A can possibly harm the unit. This can occur in areas where either vaporized oils are present, or where low viscosity cutting oils are allowed to adhere to the unit for long periods of time. If the PS-A unit's front face protection sheet becomes peeled off, these conditions can lead to the ingress of oil into the PS-A and separate protection measures are suggested. Also, if non-approved oils are present, it may cause deformation or corrosion of the front panel's plastic cover. Therefore, prior to installing the PS-A be sure to confirm the type of conditions that will be present in the PS-A unit's operating environment.*

If the installation gasket is used for a long period of time, or if the unit and its gasket are removed from the panel, the original level of the protection cannot be guaranteed. To maintain the original protection level, Schneider Electric recommends that you replace the installation gasket regularly.

4 Dip Switches

The dip switches are located on the circuit board inside the PS-A unit's rear cover. For information about removing the Rear cover, **Reference** 6. Installation.

The factory settings are all OFF.

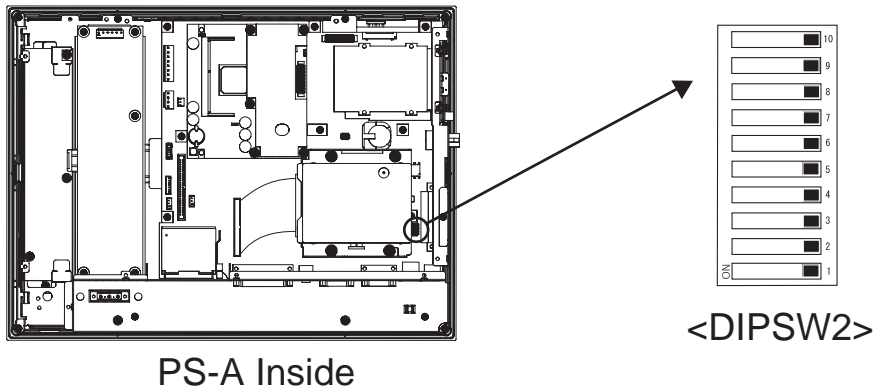

Dip Switches	Description	ON	OFF	RS-232C (COM1)	RS-232C (COM2)	RS-422 (COM2)	RS-485 (COM2)
1	Changes #9 pin (RI <-> +5V)	+5V 500mA external output possible	RI	ON/OFF	ON/OFF	ON/OFF	ON/OFF
2	Changes COM2's communication method	RS-422/RS-485	RS-232C	OFF	OFF	ON	ON
3	Changes COM2 (RS-232C) #9 pin (RI <-> +5V)	+5V 500mA external output possible	RI	ON/OFF	ON/OFF	ON/OFF	ON/OFF
4	Changes TX data's output mode	TX data output is NOT controlled via the RTS signal	TX data output is controlled via the RTS signal. (normally output)	OFF	OFF	ON/OFF	ON
5	Switches the TX termination resistance ON/OFF	Inserts termination resistance of 220Ω between TXA and TXB.	No termination	OFF	OFF	ON	ON/OFF *1
6	Switches the RX termination resistance ON/OFF	Inserts termination resistance of 220Ω between RXA and RXB.	No termination	OFF	OFF	ON	ON/OFF *1
7	Switches the shorting of TXA and RXA ON or OFF	Shorts TXA and RXA (RS-485 mode)	No shorting (RS-422 mode)	OFF	OFF	OFF	ON
8	Switches the shorting of TXB and RXB ON or OFF	Shorts TXB and RXB (RS-485 mode)	No shorting (RS-422 mode)	OFF	OFF	OFF	ON
9	Changes COM2's communication method	RS-422/RS-485	RS-232C	OFF	OFF	ON	ON
10	No Connection	-	-	-	-	-	-

*1 If you use the termination resistance, base your settings on the connection specifications.

The COM2 compatible Serial Mode Select Switches (SW4 to SW8) operate as shown in the circuit diagram below.

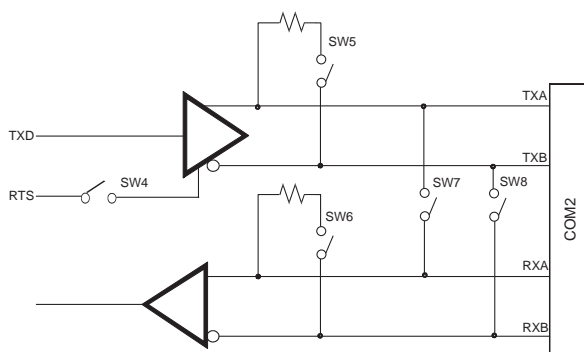

5 Interfaces

Serial Interface (COM1,COM2)

◆COM1(RS-232C)

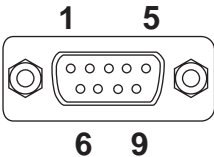
Pin Arrangement	Pin No.	Signal	Signal Name	Direction
	1	CD	Carrier Detect	Input
	2	RXD	Receive Data	Input
	3	TXD	Send Data	Output
	4	DTR	Data Terminal Ready	Output
	5	GND	Signal Ground	-
	6	DSR	Data Set Ready	Input
	7	RTS	Request Send	Output
	8	CTS	Clear Send	Input
	9	RI/+5V	Ring Indicate/+5V - Power Supply for External Devices	In/Output
	FG	FG	Frame Ground	-

To change the RI/+5V setting of #9 pin, open the PS-A unit's rear cover and set dip switch (DIPSW2) to the desired position.

▼ **Reference** 4 . Dip switches



Note: Use inch type (#4-40UNC) threads to hold the cable's set (fastening) screws in place.

◆COM2

COM2 can be changed to either RS-232C, RS-422 or RS-485. The default setting is RS-232C. To change this setting to RS-422 or RS-485, open the PS-A unit's rear cover and set dip switch (DIPSW2) to the desired position.

▼ **Reference** 4 . Dip switches

(RS-232C)

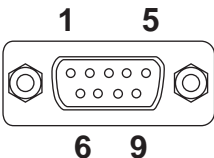
Pin Arrangement	Pin No.	Signal	Signal Name	Direction
	1	CD	Carrier Detect	Input
	2	RXD	Receive Data	Input
	3	TXD	Send Data	Output
	4	DTR	Data Terminal Ready	Output
	5	GND	Signal Ground	-
	6	DSR	Data Set Ready	Input
	7	RTS	Request Send	Output
	8	CTS	Clear Send	Input
	9	RI/+5V	Ring Indicate/+5V - Power Supply for External Devices	In/Output
	FG	FG	Frame Ground	-

In RS-232C mode, the RI/+5V setting of #9 pin can be changed. To change this setting, open the PS-A unit's rear cover and set dip switch (DIPSW2) to the desired position.

▼ **Reference** 4 . Dip switches

(RS-422)

Pin No.	Signal	Signal Name	Direction
1	RXA	Receive Data (+)	Input
2	RXB	Receive Data (-)	Input
3	TXA	Send Data (+)	Output
4	NC	No Connection	-
5	GND	Ground	-
6	NC	No Connection	-
7	TXB	Send Data (-)	Output
8	NC	No Connection	-
9	NC	No Connection	-
FG	FG	Frame Ground	-

(RS-485)

Pin No.	Signal	Signal Name	Direction
1	DATE+	Send/Receive Data (+)	In/Output
2	DATE-	Send/Receive Data (-)	In/Output
3	NC	No Connection	-
4	NC	No Connection	-
5	GND	Ground	-
6	NC	No Connection	-
7	NC	No Connection	-
8	NC	No Connection	-
9	NC	No Connection	-
FG	FG	Frame Ground	-



- *Be sure to connect pin number 5 (SG) of COM1 to the host unit's Signal Ground terminal.*
- *Be sure to confirm what settings will be used by the other device and set the dip switches accordingly. Failure to do so can result in a unit malfunction or damage.*
- *Whenever changing the PS-A switches, be sure to first turn the PS-A's power supply OFF. Failure to do so can cause a PS-A malfunction.*
- *Connect the FG terminal line to the connector cover's PS-A connector attachment screw.*
- *FG and SG terminals are internally connected in the PS-A. When connecting to another device, be sure to create an SG shorting loop in your system.*



Use inch type (#4-40UNC) threads to hold the cable's set (attachment) screws in place.

■ Printer Interface (LPT1)

This interface conforms to Centronics standards.



Electrical specifications

- **O.D** : Open Drain
- **T.S** : State Input/Output
- **TTL** : TTL Input

Pin Arrangement	Pin No.	SPP/EPP Mode Signal Name	EPP Mode Signal Name	Direction	Electrical Specification
	1	STRB	WRITE	In/Output	O.D/T.S * ¹
	2	DATA0	DATA0	In/Output	O.D
	3	DATA1	DATA1	In/Output	O.D
	4	DATA2	DATA2	In/Output	O.D
	5	DATA3	DATA3	In/Output	O.D
	6	DATA4	DATA4	In/Output	O.D
	7	DATA5	DATA5	In/Output	O.D
	8	DATA6	DATA6	In/Output	O.D
	9	DATA7	DATA7	In/Output	O.D
	10	ACKNLG	ACKNLG	Input	TTL
	11	BUSY	WAIT	Input	TTL
	12	PE	PE	Input	TTL
	13	SLCT	SLCT	Input	TTL
	14	AUTOFD	DSTRB	In/Output	O.D/T.S * ¹
	15	ERROR	ERROR	Input	TTL
	16	INIT	INIT	In/Output	O.D/T.S * ¹
	17	SLCTIN	ADSTRB	In/Output	O.D/T.S * ¹
	18	GND	GND	-	-
	19	GND	GND	-	-
	20	GND	GND	-	-
	21	GND	GND	-	-
	22	GND	GND	-	-
	23	GND	GND	-	-
	24	GND	GND	-	-
	25	GND	GND	-	-

*1 Pins 1, 14, 16 and 17 will become O.D when the SPP mode specification is used. If the mode changes to ECP or EPP, these pins will become T.S.

■ PS2 Keyboard Interface (KEYBOARD)

This is a PS2 compatible Keyboard Interface.

■ Ethernet Interface (LAN)

This interface complies with the IEEE802.3 Ethernet communication standard (10BASE-T/100BASE-TX Auto Changeover).

■ USB Interfaces (USB)

These interfaces are used to connect USB equipment. (Ver.1.1 compatible)

■ PCMCIA Interfaces (PCMCIA)

These interfaces are used to connect PCMCIA Type I, Type II cards.

■ Speaker Output Interface (SPEAKER)

This interface uses a mini-pin jack-type connector.

■ CF Card Interface

This interface accepts a CF Card, and uses an IDE connection *1.

■ CD-ROM Drive Interface

This interface is used to connect Digital's CD-ROM Drive unit (PSS-CD01).

6 Installation

■ Confirm the Installation Gasket's Positioning

It is strongly recommended that you use the installation gasket.

Place the PS-A on a level surface with the display panel facing downward.

Check that the PS-A's installation gasket is seated securely into the gasket's groove, which runs around the perimeter of the panel's frame.



- Before installing the PS-A unit into a cabinet or panel, check that the installation gasket is securely attached to the unit.
- A gasket which has been used for a long period of time may have scratches or dirt on it, and could have lost much of its water resistance. Be sure to change the gasket at least once a year, or when scratches or dirt become visible.
- Be sure to use gasket model CA3-WPG15-01.
- Be sure the gasket's seam is not inserted into any of the unit's corners, only in the straight sections of the groove. Inserting it into a corner may lead to its eventually tearing.
- To ensure the installation gasket's maximum level of moisture resistance, be sure the gasket's seam is inserted as shown into the panel's bottom face.

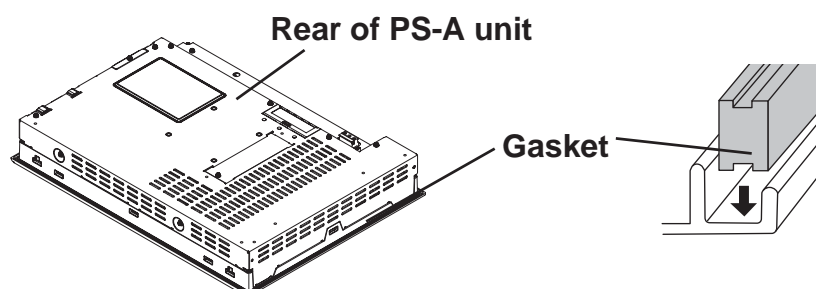

*1 Since an IDE-type connection is used, the unit is not hot-swappable. When removing the unit, be sure that power is turned OFF.

■ Create a Panel Cut

Insert the PS-A unit into the panel from the front.

Unit: mm [in.]

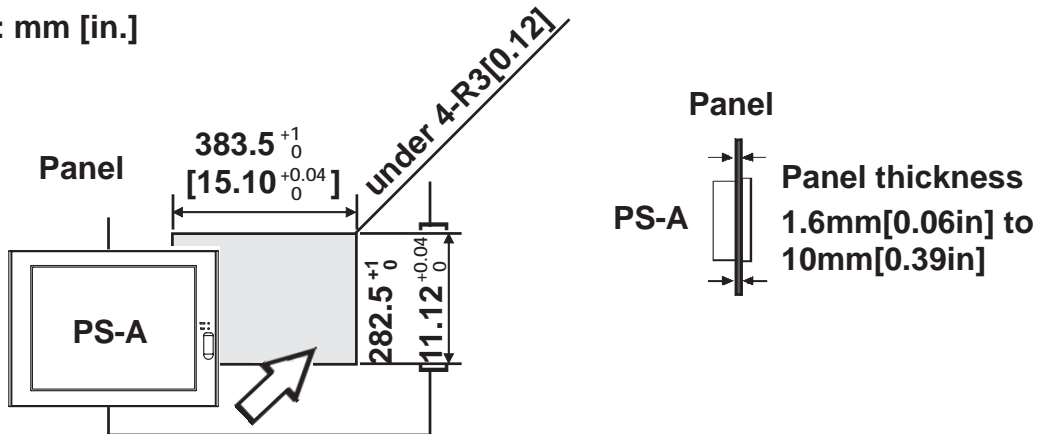

■ Attach the Installation Fasteners from Inside the Panel

The following figures show the eight (8) insertion slot locations of the PS-A installation fasteners. Insert the hook section into the slot and tighten the fastener with a screwdriver, as shown.

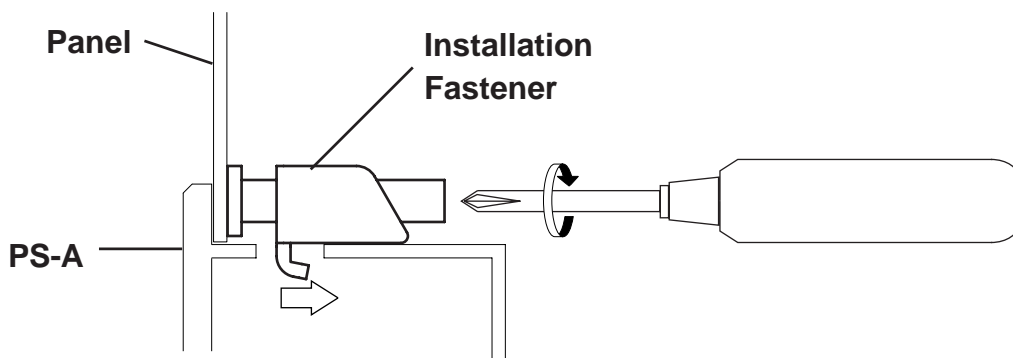
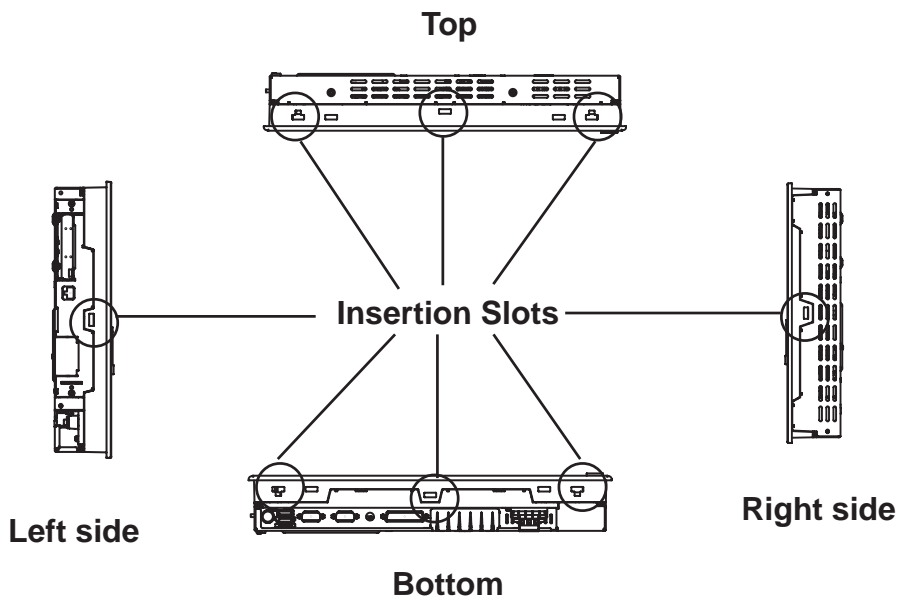



- Do not tighten the screws with too much force, since it can damage the PS-A unit's.
- The torque necessary to create a drip-resistant seal is 0.5 N•m.



- Depending on the installation panel's thickness, etc., the number of installation fasteners used may need to be increased to provide the desired level of moisture resistance.
- Be sure to use installation fastener model CA3-ATFALL-01.

■ Attach the PS-A unit to an Arm

To attach the PS-A unit to an Arm or to the wall, insert the attachment screws for a commercial-type arm or wall mount adaptor into the holes in the PS-A's rear face. (Holes specifications: VESA 75mm)

For detailed attachment instructions, please refer to that product's installation guide. The VESA Arm Attachment Hole dimensions are signified as follows;

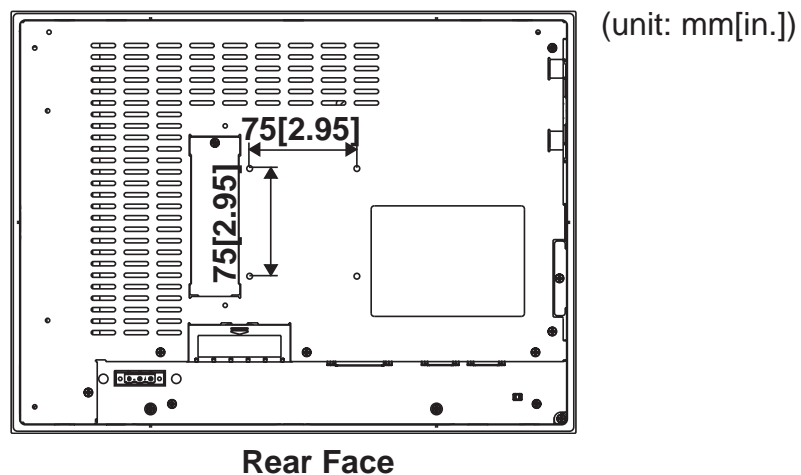

Attach the four (4) M4 attachment screws. (Screw length : 6mm or less.) The torque required for these screws is 0.7 to 0.8 N.m.

■ Installation Requirements

- To enhance the PS-A's maintainability, operability and ventilation, allow at least 100 mm clearance between the PS-A and other objects. (The clearance must be large enough to allow you to install or uninstall option units and to attach connectors.)

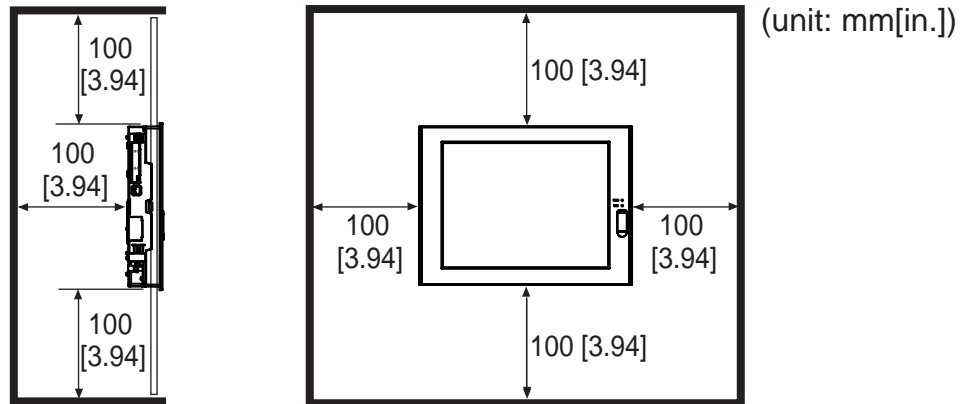

- Standard installation for the PS-A unit is in a vertical panel. If the PS-A unit is to be installed in a slanted panel, the panel should not incline more than 30° from the vertical.
- Horizontal installation (that is, rotating the panel so that one of its sides is the base) is not supported.

■ Removal/Attachment the Rear Cover



- Use a screwdriver to loosen or tighten the screws. Be sure not to tighten screws too tightly, since it may damage the unit.
- Be careful when removing or inserting any screws that they do not fall inside the PS-A.

Unscrew the eight (8) attachment screws used to hold the Rear Cover in place, and remove the Rear Cover.

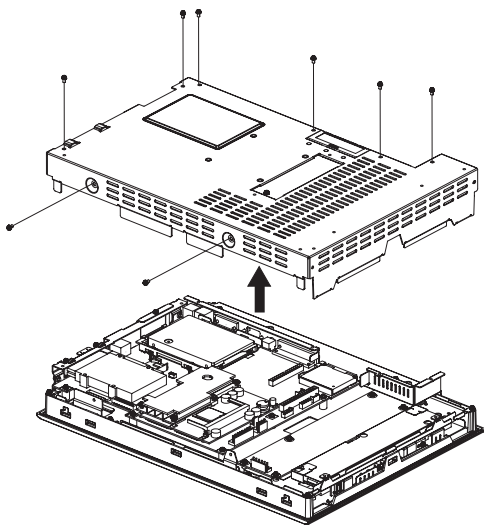

■ USB Cable Holder Installation

This holder prevents the USB cable from becoming disconnected due to vibration, etc. Place the PS-A unit face-down on a flat surface as shown below. Your PS-A unit has two USB connectors.

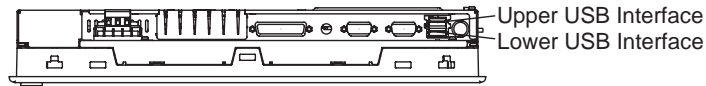

Note:

- When using both USB connectors, be sure to first connect one USB cable to the lower USB connector, then connect the second USB cable to the upper USB connector.
- When using only one of the USB ports, be sure to use the lower USB connector. This allows you to securely clamp the USB cable in the cable clamp.

[Attachment]

As shown below, insert the USB Cable Clamp's band through the Bridge. Pass the USB cables through the Cable Clamp's band and securely tighten the clamp band around the cables.



Note:

- Be sure the clamp is securely holding the USB cable's plug and collar.
- Be sure the clamp is positioned as shown below, with the clamp pointing upwards – not to the side. This is to keep the clamp from interfering with nearby connectors and their cables.

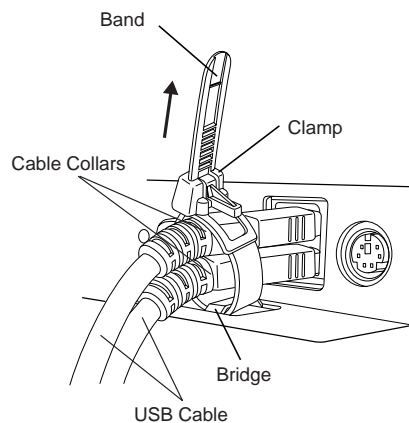

[Removal]

To remove the clamp from the USB cables, push down on the clamp strap's clip to release it while pulling up on the clamp.

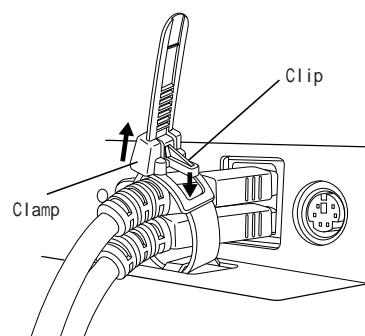

7 Wiring

WARNINGS

- To avoid an electric shock, check that the PS-A unit's power supply is completely turned OFF, via a breaker or similar unit before connecting the PS-A power cord terminals to the PS-A unit's power terminal block.
- The PS3701A-T41-DU-E66 unit can accept only DC24V input. If you use power other than DC24V, you can damage both the power supply and the PS-A unit.
- Since the PS-A unit has no power ON/OFF switch, be sure to attach a breaker-type switch to its power cord.



When the FG terminal is connected, be sure the wire is grounded.
Not grounding the PS-A unit will result in excess noise and vibration.



- Wherever possible, use thick wires (max. 2 mm²) for PS-A power Plug. Also, to reduce noise be sure to twist the wire ends.
- Recommended power plug is Phoenix Contact Co.'s GMVSTB2.5-3-STF-7.62.

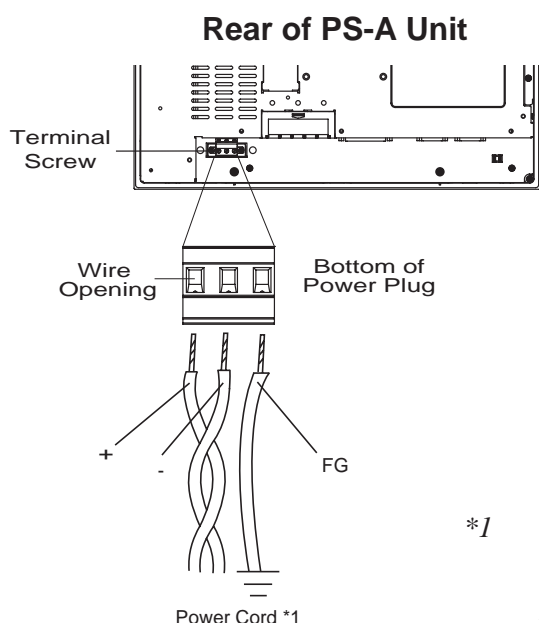

*1 + : Positive electrode
- : Negative electrode

FG : Ground Terminal connected to the PS-A chassis

■ Connecting the PS-A unit's Power Cord Terminals

When connecting the power cord, be sure to follow the procedures given below.

1. Confirm that the PS-A unit's power cord is unplugged from the power supply.
2. Loosen the three (3) screws from the power plug.
3. Remove the insulation of the power cord's 3 internal wires and insert each wire into the Power Plug's wire opening.
4. Re-attach the screws.



- The torque required to tighten these screws is 0.5 to 0.6N•m.
- Do not solder the wire itself.
- If the wire's strands are not twisted carefully, the end strands may either short against each other, or against an electrode.

8 Power Supply Cautions

Please pay special attention to the following instructions when connecting the power plug to the PS-A unit.

- If the power supply voltage exceeds the PS-A unit's specified range, connect a voltage transformer.
- Between the line and the ground, be sure to use a low noise power supply. If there is still an excessive amount of noise, connect a noise reducing transformer.



Note: Be sure any constant or insulating transformer used has a capacity of 200VA or more.

- Input and Output signal lines must be separated from the power control cables for operational circuits.
- To increase noise resistance, be sure to twist the ends of the power cord wires before connecting them to the PS-A unit's power terminal block.
- The PS-A unit's power supply cord should not be bundled with or kept close to main circuit lines (high voltage, high current), or input/output signal lines.
- Connect a surge absorber to handle power surges.



- **Ground the lightning surge absorber and the PS-A separately.**
- **Select a lightning surge absorber which will not exceed the allowable circuit voltage, even when the voltage rises to the maximum.**

- To reduce noise, make the power cord as short as possible.

9 Grounding Cautions

- When attaching a wire to the PS-A unit's rear face FG terminal, (on the Power Input Terminal Block), be sure to create an exclusive ground.*1
- FG and SG terminals are internally connected in the PS-A. When connecting to another device, be sure to create an SG shorting loop in your system.

10 Input/Output Signal Line Cautions

- Input and Output signal lines must be separated from the power control cables used for operational circuits.
- If this is not possible, use a shielded cable and the shield should be grounded.

*1 Use a grounding resistance of 100Ω, a wire of 2mm² or thicker, or your country's cable standard.

11 Replacing the Backlight

- The PS-A unit's backlight is user replacable. For an explanation of how to replace the PS-A unit's backlight, please refer to the instruction manual which comes with the replacement backlights (sold separately).
- Be sure to use backlight model CA3-BLU15-01.



Using any backlight other than the model written above may cause an accident or PS-A unit malfunction.

Note

Be aware that the Digital Electronics Corporation shall not be held liable for any real or estimated damages or losses, or third party claims resulting from the use of this product.