



## WARNINGS

- When inserting the Compact Panel Computer PS-3700A(Pentium®4M-1.7GHz Model) (hereafter referred to as the "PS-A")'s power cord into the PS-A's AC Connector, check first that the PS-A's power supply is completely turned OFF, via a breaker, or similar unit.
- Before either plugging in or unplugging a board or interface connector, be sure to turn the PS-A's power OFF.
- Whenever changing the Backlight, to prevent electric shocks and burns, be sure to turn OFF the PS-A's power and wear protective gloves.
- After the PS-A's backlight burns out, unlike the PS-A's "Standby Mode", the touch panel is still active. If the operator fails to notice that the backlight is burned out and touches the panel, a potentially dangerous machine miss-operation can occur.  
If your PS-A's backlight suddenly turns OFF, use the following steps to determine if the backlight is actually burned out.
  - 1) If your PS-A is not set to "Standby Mode" and the screen has gone blank, your backlight is burned out.
  - 2) Or, if your PS-A is set to Standby Mode, but touching the screen does not cause the display to reappear, your backlight is burned out.
- Do not open or remodel the PS-A unit, since it may lead to a fire or electric shock.
- Do not use power beyond the PS-A's specified voltage range. Doing so may cause a fire or an electric shock.
- Do not use the PS-A in an environment where flammable gases are present, since operating the PS-A may cause an explosion.
- The PS-A uses a lithium battery for backing up its internal clock data. If the battery is incorrectly replaced (i.e. its + and - sides are reversed), the battery may explode. When changing the battery, please contact your local PS-A distributor.
- Do not use the PS-A unit as a warning device for critical alarms that can cause serious operator injury, machine damage or production stoppage. Critical alarm indicators and their control/activator units must be designed using stand-alone hardware and/or mechanical interlocks.
- To prevent operator injury or machine damage, be sure to design your machine operation system so that the machine will not malfunction due to a communication fault between the PS-A and its host controller.
- Do not use PS-A touch panel switches in life-related or important disaster prevention situations. For safety related switches, such as an emergency switch, be sure to use a separate mechanical switch.
- The PS-A is not appropriate for use with aircraft control devices, aerospace equipment, central trunk data transmission (communication) devices, nuclear power control devices, or medical life support equipment, due to these devices inherent requirements of extremely high levels of safety and reliability.
- When using the PS-A with transportation vehicles (trains, cars and ships), disaster and crime prevention devices, various types of safety equipment, non-life support related medical devices, etc. redundant and/or failsafe system designs should be used to ensure the proper degree of reliability and safety.

### **To prevent this unit from malfunctioning :**

- In order to extend the lifetime of the hard disk, Pro-face recommends you set the Windows [Control panel]-[Power Management option]-[Turn off hard disks] selection to turn the hard disk off when the unit is not being operated. A setting of 5 minutes is recommended.
- Do not strike the PS-A's touch panel with a hard or heavy object, or press on the touch panel with excessive force, since it may damage the display.
- Do not install the PS-A where the temperature will exceed its specified range.
- Be sure that water, liquids or metal particles do not enter the PS-A, since it may cause a malfunction or a short circuit.
- Avoid installing the PS-A where sudden, large changes in temperature may occur. These changes may cause condensation to form inside the unit, possibly causing a malfunction.
- To prevent excessive heat from building up inside the PS-A, do not install it where its ventilation holes may be blocked. Also, do not install or store the PS-A near high temperature equipment.
- Do not install or store the PS-A in direct sunlight or where high levels of dust exist.
- Since the PS-A is a precision instrument, do not install or store it where either strong shocks or excessive vibration may occur.
- Do not install or store the PS-A in an area containing chemicals or chemical fumes.
- Do not use paint thinner or organic solvents to clean the PS-A's case or screen.
- Due to the danger of unforeseeable accidents, back up all PS-A data regularly.
- After turning this unit OFF, be sure to wait a few seconds before turning it ON again. If the unit is started too soon, it may not start up correctly.

# UL/CSA Application Notes

The PS3700A-T41-ASU-P41 is a UL/CSA listed product (UL File No. E220851). Please pay special attention to the following instructions when applying for UL/CSA approval for machinery which includes this PS-A unit.

**The PS-A conforms as a component to the following standards:**

- **UL508** Industrial Control Equipment
- **CAN std C22.2 No.14-1995, CAN/CSA22.2 No.60950**

**PS3700A-T41-ASU-P41 (UL Registration Model No.:3180046-01)**

- Equipment with a PS-A unit mounted in it requires UL/CSA evaluation for the combination of the PS-A and equipment.
- The PS-A must be used as a built-in component of an end-use product.
- Use the PS-A indoors only.
- When connecting the PS-A's power cord, be sure to use a cord that is appropriate for the current and voltage used and that has conductive wires that are 0.75 mm<sup>2</sup> or larger.
- When using the PS-A in an end-use product, be sure to install the PS-A unit's power cut-off switch where the operator can easily reach it.
- Danger of explosion if backup battery is incorrectly replaced. Should be replaced only with same or equivalent type recommended by the manufacturer. Dispose of used batteries according to the manufacturer's instructions.
- Be sure the unit the PS-A is built into uses a UL508 compatible structure.

# CE Marking Notes

The PS3700A-T41-ASU-P41 is a CE marked, EMC compliant product.

**<Complies with the following Standards>**

- **Safety**  
EN60950
- **EMI**  
EN61000-6-4, EN55011(Group 1, Class A)
- **EMS (EN61000-6-2)**  
EN61131-2, EN61000-4-2, EN61000-4-3, EN61000-4-4, EN61000-4-5, EN61000-4-6, EN61000-4-8, EN61000-4-11, EN61000-4-12
- **FCC**  
47 CFR Part15 Class A

If the following requirements are not met, the PS-A may fail to meet EN60950 standard requirements.

- The PS-A must be used as a built-in component of an end-use product.
- Use the PS-A indoors only.
- When connecting the PS-A's power cord, be sure to use a cord that is appropriate for the current and voltage used and that has conductive wires that are 0.75 mm<sup>2</sup> or larger.
- When using the PS-A in an end-use product, be sure to install the PS-A unit's power cut-off switch where the operator can easily reach it.
- There is a danger of explosion if the backup battery is incorrectly replaced. This battery should be replaced only with same or equivalent type recommended by the manufacturer. Dispose of used batteries according to the manufacturer's instructions.
- Be sure the PS-A unit's enclosure is an EN60950 approved sheet steel structure.

# Package Contents

The following items are included in the PS-A's package. Before using the PS-A, please confirm that all items listed here are present.

■ PS-A Unit (1)

(PS3700A-T41-ASU-P41)

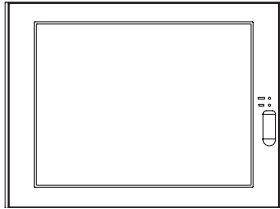

■ Installation Gasket (1)



■ Installation Fasteners (4/set ×2)

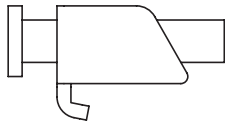

■ USB Cable Clamp (1)



■ AC Power Cord (1)

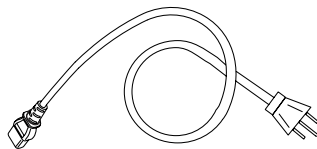

■ AC Power Cord Clamp (1)

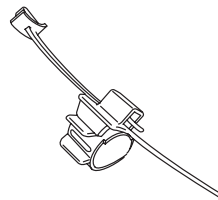

■ CD-ROM (1)



■ Installation Guide (1)

<This Guide>



- *Be careful when installing the PS-A not to damage the built-in HDD.*
- *The Power Cord included in the FP unit's package is designed only for AC100V or AC115V use. Any other voltage will require a different cord.*



- **The CD-ROM included in this package contains a User Manual, RAS-API Reference Manual, and PS-A Series Utility and Driver files. Please refer to PDF manuals.**

This unit has been carefully packed, with special attention to quality. However, should you find anything damaged or missing, please contact your local PS-A distributor immediately. When you order a PS-A unit built to your specifications, that PS-A package should include each optional item's Installation Guide. Please use that guide to check the contents of each optional item's package.

# About The Manual

The PS-A unit's CD-ROM contains the following PDF manual files.

- Compact Panel Computer PS-3700A (Pentium® 4M - 1.7GHz Model) User Manual (psap4e.pdf )
- PS Series Type A (Pentium® 4M - 1.7GHz Model) API Reference Manual (psap4ape.pdf)

Reading a PDF file requires installation of the Adobe Corporation's Acrobat® Reader.

## ■ Acrobat® Reader Installation:

To install the Acrobat® Reader software, follow the steps given below.

- 1) This software, in the form of a self-extracting file, is located in this CD-ROM in the folder titled [reader]. Use the Explorer software to find the file [Reader\Eng\ar505enu.exe], and double-click on the file icon to begin the Reader installation.
- 2) After installation begins, follow the instructions given.

## ■ Viewing the PDF manual:

To view the PDF manual contained in this CD-ROM, follow the steps given below.

- 1) Use the Explorer software to locate the file [Manual\Eng\psap4e.pdf or psap4ape.pdf] in the folder titled [Manual].
- 2) Double-click on the PDF file's icon. Acrobat® Reader will automatically start and the first page of the PDF manual will appear.

# 1 Part Names

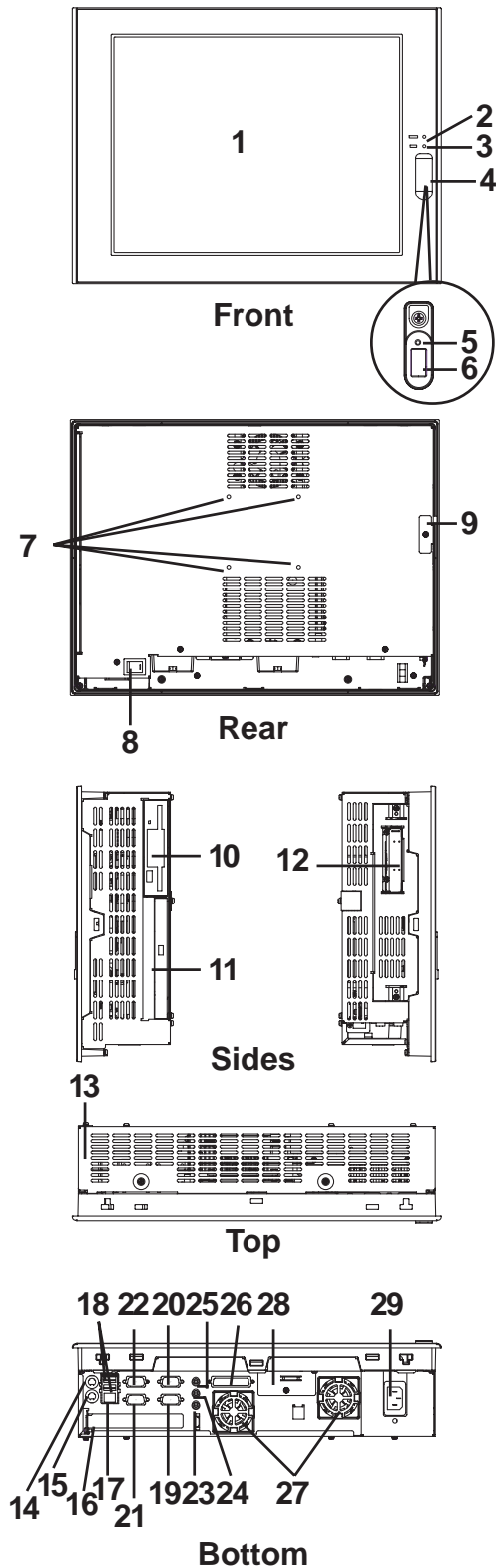

- 1 : Display / Touch Panel
- 2 : Power Lamp LED (POWER)

LED	PS-A Status
Green	Normal Operation (Power On)
Orange	System Monitor Error Touch Panel Self Test Error
Orange/Red	Backlight is not functioning

- 3 : IDE Access Lamp

LED	PS-A Status
Green	Currently using IDE I/F

- 4 : Front Packing
- 5 : Hardware Reset Switch (RESET)
- 6 : USB Connector (1 port)  
[USB Ver. 1.1 compatible] \*1
- 7 : Arm Attachment Screw Holes  
[VESA 75mm]
- 8 : Power Switch
- 9 : Expansion Board Support
- 10 : FD Drive
- 11 : CD-ROM Drive
- 12 : PCMCIA Connectors (PCMCIA)(2 ports)
- 13 : Rear Cover
- 14 : Mouse Connector (MOUSE)
- 15 : Keyboard Connector (KEYBOARD)
- 16 : Expansion Slot
- 17 : LAN Connector (LAN)  
[10 BASE-T /100 BASE-TX]
- 18 : USB Connectors (2 ports)  
[USB Ver. 2.0 compatible]
- 19 : RS-232C Connector (COM1)  
[+5V/RI Changeover]
- 20 : RS-232C Connector (COM2)  
[+5V/RI Changeover]
- 21 : RS-232C Connector (COM3)  
[RS-422/RS-485 Changeover]
- 22 : RS-232C Connector (COM4)
- 23 : Line Input Connector (LINE IN)
- 24 : Speaker Output Connector  
(SPEAKER)
- 25 : Mike Input Connector (MIC IN)
- 26 : Printer Connector (LPT1)
- 27 : Cooling FAN
- 28 : CF Card Slot
- 29 : AC Inlet Connector

\*1 USB HUB and USB Ver. 2.0 compatible devices cannot be connected.



- Prior to attaching peripheral units to the PS-A, be sure the PS-A's power cord is disconnected from the main power supply.
- To prevent an electrical shock, be sure to disconnect the PS-A's power cord from the power supply before connecting the cord or any peripheral devices to the PS-A.

## 2 Dimensions

### ■ PS-A Unit

Unit:mm [in]

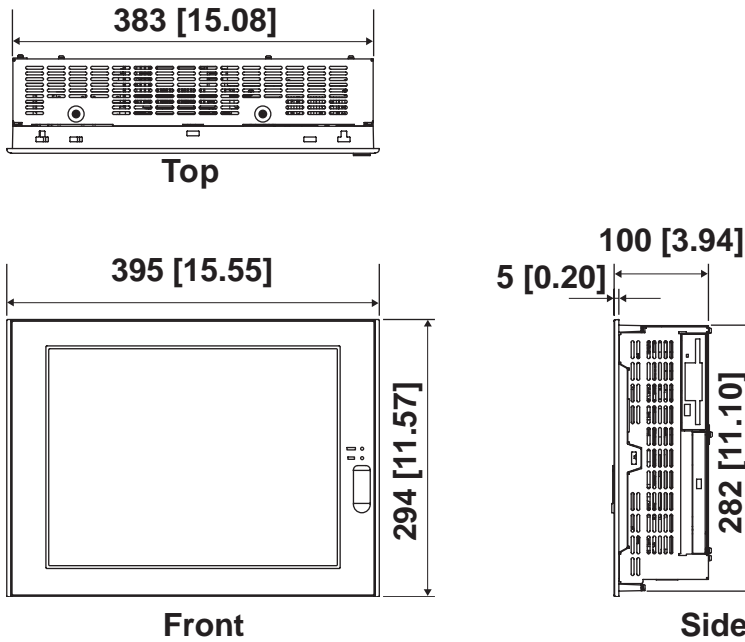

### ■ External Dimensions (with Installation Fasteners installed)

Unit:mm [in]

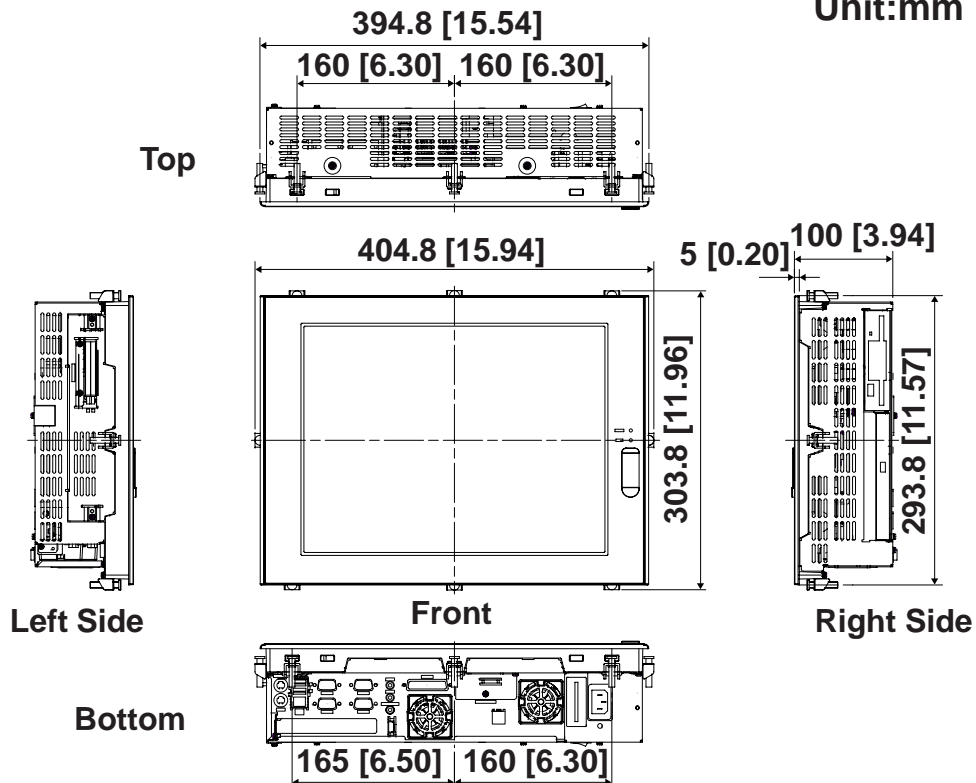

### 3 General Specifications

#### ■ Electrical

Rated Voltage	AC100V / AC240V
Voltage Supply Range	AC85V to AC265V
Rated Frequency	50/60Hz
Allowable Voltage Drop	1 cycle or less (pause occurrences must be more than 1 second apart)
Power Consumption	150VA or less
Voltage Endurance	AC1500V 20mA for 1 minute (between charging and FG terminals)
Insulation Resistance	10M $\Omega$ or higher at DC500V (between charging and FG terminals)

#### ■ Environment

Ambient Operating Temperature	+5 °C to +50 °C (When Using HDD) 0 °C to +50 °C (When NOT Using HDD)	
Storage Temperature	-10 °C to + 60 °C	
Ambient Humidity	10%RH to 85%RH (Non condensing, wet bulb temperature : 29°C or less)	
Storage Humidity	10%RH to 85%RH (Non condensing, wet bulb temperature : 29°C or less)	
Air Purity (Dust)	Free of dust	
Pollution Degree	Pollution Degree 2	
Corrosive Gases	Free of corrosive gases	
Vibration Resistance	When using HDD	4.9m/s <sup>2</sup> at 10Hz to 25Hz in X, Y, Z directions for 30 minutes
	When NOT using HDD	9.8m/s <sup>2</sup> at 10Hz to 25Hz in X, Y, Z directions for 30 minutes
Noise Immunity (Impulse Noise)	Noise Voltage : 1500Vp-p (via noise simulator) Pulse Duration : 50ns, 500ns, 1 $\mu$ s Rise Time : 1ns	
Noise Immunity (First transient burst noise)	Power Line : 2kV IEC 61000-4-4 COM Port : 1kV IEC 61000-4-4	
Electrostatic Discharge Immunity	4kV IEC 61000-4-2	



- *When using any of the PS-A's optional devices, be sure to check that device's specifications for any special conditions or cautions that may apply to its use.*
- *Be aware that not only does the Hard Disk have a fixed lifetime, but that accidents can always occur. Therefore, be sure to back up your Hard Disk's data regularly, or prepare another Hard Disk unit that can be used for backup.*



- *The Hard Disk lifetime given here may be reduced due to unforeseen environmental factors, however, generally speaking, the disk should last for 20,000 hours (of operation) or approximately 5 years, whichever comes first at an operating temperature of 20°C and 333 hours of operation per month. (HDD access frequency of 20% or less)*
- *Using the Hard Disk in an environment that is excessively hot and/or humid will shorten the disk's usage lifetime. A wet bulb temperature of 29°C or less is recommended. This is equivalent to the following data.*

Temperature	Humidity
at 35°C	no higher than 64%RH
at 40°C	no higher than 44%RH

- *In order to extend the lifetime of the hard disk, Pro-face recommends you set the Windows [Control panel]-[Power Management option]-[Turn off hard disks] selection to turn the hard disk off when the unit is not being operated. A setting of 5 minutes is recommended.*
- *When using CD-ROM Drive, be sure to use the PS-A unit where no excessive vibration. It causes data read error.*

## ■ Structural

Grounding	100Ω or less, or your country's applicable standard
Ratings*1	Equivalent to IP65f (JEM 1030) (When Not Using front-face USB Port unit) Design Type: Modular Installation method: Panel / VESA Arm
Cooling Method	Via Cooling Fans (for Unit/ for CPU)
Weight	Approx. 8.0kg (17.6lb)
Dimensions (W x H x D)	395 mm [15.55 in.] x 294 mm [11.57 in.] x 100 mm [3.94 in.]

\*1 *The front face of the PS-A unit, installed in a solid panel, has been tested using conditions equivalent to the standard shown in the specification. Even though the PS-A unit's level of resistance is equivalent to this standard, oils that should have no effect on the PS-A can possibly harm the unit. This can occur in areas where either vaporized oils are present, or where low viscosity cutting oils are allowed to adhere to the unit for long periods of time. If the PS-A's front face protection sheet becomes peeled off, these conditions can lead to the ingress of oil into the PS-A and separate protection measures are suggested. Also, if non-approved oils are present, it may cause deformation or corrosion of the front panel's plastic cover. Therefore, prior to installing the PS-A, be sure to confirm the type of conditions that will be present in the PS-A's operating environment. If the installation gasket is used for a long period of time, or if the unit and its gasket are removed from the panel, the original level of the protection cannot be guaranteed. To maintain the original protection level, Pro-face recommends that you replace the installation gasket regularly.*



## 4 Interfaces

### ■ Serial Interface (COM1,COM2,COM3,COM4)

#### ◆ RS-232C Interface (COM1, COM2, COM3, COM4)

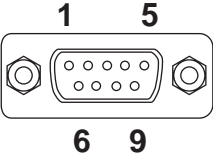
Pin Arrangement	PIN#	Signal	Condition	Direction
	1	CD	Carrier Detect	Input
	2	RXD	Receive Data	Input
	3	TXD	Send Data	Output
	4	DTR	Data Terminal Ready	Output
	5	GND	Signal Ground	-
	6	DSR	Data Set Ready	Input
	7	RTS	Request Send	Output
	8	CTS	Clear Send	Input
	9	RI/5V	Ring Indicate	In/Output
	FG	FG	Frame Ground	-

#### ◆ RS-422 Interface (COM3)

Pin#	Signal	Condition	Direction
1	RXA	Receive Data (+)	Input
2	RXB	Receive Data (-)	Input
3	TXA	Send Data (+)	Output
4	NC	No Connection	-
5	GND	Ground	-
6	NC	No Connection	-
7	TXB	Send Data (-)	Output
8	NC	No Connection	-
9	NC	No Connection	-
FG	FG	Frame Ground	-

#### ◆ RS-485 Interface (COM3)

Pin#	Signal	Condition	Direction
1	DATA+	Send/Receive Data (+)	In/Output
2	DATA-	Send/Receive Data (-)	In/Output
3	NC	No Connection	-
4	NC	No Connection	-
5	GND	Signal Ground	-
6	NC	No Connection	-
7	NC	No Connection	-
8	NC	No Connection	-
9	NC	No Connection	-
FG	FG	Frame Ground	-



- COM3 and COM4 cannot be used for +5V Output.
- Do not connect any pins to COM3 [NC].
- No. 5 pin (GND) for RS-232C (COM1, COM2, COM3, COM4) is the signal ground. Be sure to connect the GND terminal to the other unit's SG (signal ground) terminal.
- Be sure to confirm what settings will be used by the other device when setting the switches. Failure to do so can result in a unit malfunction or damage.
- Whenever changing any PS-A switch settings, be sure to first turn the PS-A's power supply OFF. Failure to do so can cause a PS-A malfunction.
- Connect the FG terminal line to the connector cover's PS-A connector attachment screw.
- FG and SG terminals are internally connected in the PS-A. When connecting to another device, be sure to create an SG shorting loop in your system.



Use inch type (#4-40UNC) threads to hold the cable's set (attachment) screws in place.

### ◆ Switches

The following switch settings corresponding to each Serial Interface need to be signified. To set the switches, remove the PS-A's Rear Cover and locate the following switches, next to the PS-A's circuit board. For information about attaching/removing the Rear Cover, [Reference 5. Installation ■ Removing and Installing the Rear Cover](#) The switches are located as follows;

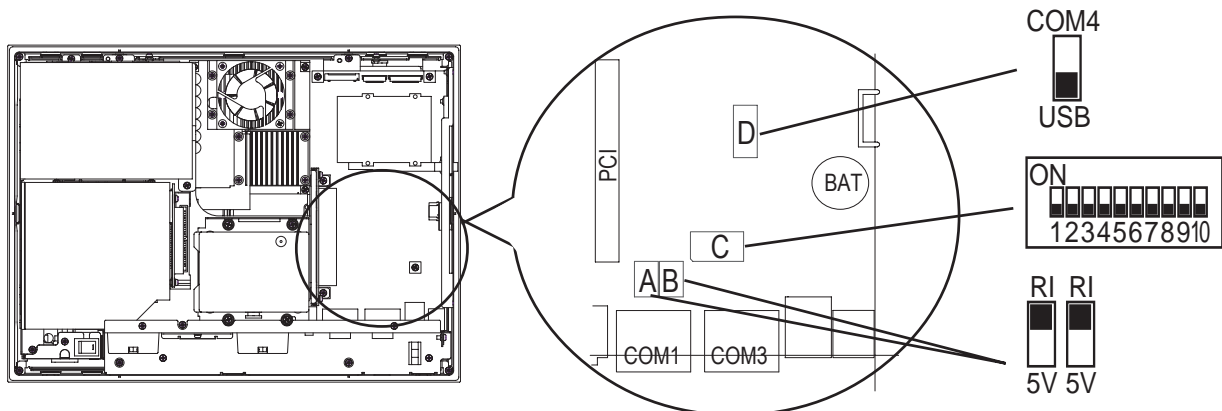

Switch Location	Switch Name	Compatible I/F	Description
A	+5V/RI Changeover SW	COM1	Changes # 9 pin (RI <---> 5V).
B	+5V/RI Changeover SW	COM2	The factory setting is RI.
C	Serial Mode Select SW	COM3	10-point dip switch. Designates COM3 communication settings. For Serial Mode Select SW details, see Table (1). The factory settings are all OFF. (RS-232C)
D	Touch Panel's Communication Changeover SW	COM4 USB	Changes the Touch Panel communication method. (Serial <---> USB) The factory setting is USB. (If "Serial" is selected, COM4 cannot be used.)

SW No.	Description	ON	OFF	RS-232C	RS-422	RS-485
1	Used by the system	Reserved	Reserved	OFF <sup>*1</sup>	OFF <sup>*1</sup>	OFF <sup>*1</sup>
2	Changes COM3's communication method	RS-422/RS-485	RS-232C	OFF	ON	ON
3	Changes COM3's communication method	RS-422/RS-485	RS-232C	OFF	ON	ON
4	Changes TX data's output mode	TX data output is controlled via the RTS signal.	TX data output is NOT controlled via the RTS signal. (normally output)	OFF	ON/OFF	ON
5	Switches the TX termination resistance ON/OFF	Inserts termination resistance of 220Ω between TXA and TXB.	No termination	OFF	ON	ON/OFF <sup>*2</sup>
6	Switches the RX termination resistance ON/OFF	Inserts termination resistance of 220Ω between RXA and RXB.	No termination	OFF	ON	ON/OFF <sup>*2</sup>
7	Switches the shorting of TXA and RXA ON or OFF	Shorts TXA and RXA (RS-485 mode)	No shorting (RS-422 mode)	OFF	OFF	ON
8	Switches the shorting of TXB and RXB ON or OFF	Shorts TXB and RXB (RS-485 mode)	No shorting (RS-422 mode)	OFF	OFF	ON
9	Used by the system	Reserved	Reserved	OFF <sup>*1</sup>	OFF <sup>*1</sup>	OFF <sup>*1</sup>
10	Used by the system	Reserved	Reserved	OFF <sup>*1</sup>	OFF <sup>*1</sup>	OFF <sup>*1</sup>

**Table (1) Serial Mode Select SW**

( The factory settings are all OFF. Compatible I/F: COM3 )

\*1 Be sure to keep the settings, "OFF".

\*2 If you use termination resistance, base your settings on your connection specifications.

The COM3 compatible Serial Mode Select Switches (SW4 to SW8) operate as shown in the circuit diagram below.

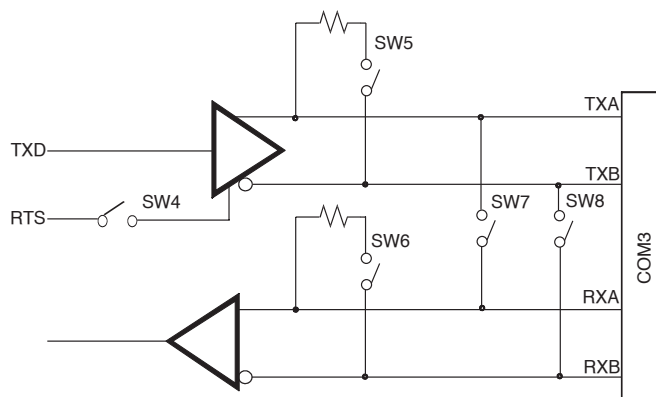
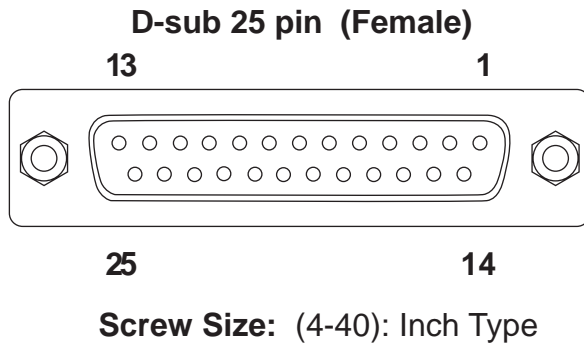

Fig. 1 Serial Mode Select Switches (SW4 to SW8) circuit diagram

## ■ Printer Interface (LPT1)

This interface conforms to Centronics standards.



**Note:** **Electrical Specifications**  
**O.D** : Open Drain  
**T.S** : 3 state I/O  
**TTL** : TTL Input

Pin No.	SPP/ECP Mode Signal Name	EPP Mode Signal Name	Direction	Electrical Specif.	Pin No.	SPP/ECP Mode Signal Name	EPP Mode Signal Name	Direction	Electrical Specif.
1	STRB	WRITE	In/Output	O.D/T.S <sup>*1</sup>	14	AUTOFD	DSTRB	In/Output	O.D/T.S <sup>*1</sup>
2	DATA0	DATA0	In/Output	O.D	15	ERROR	ERROR	Input	TTL
3	DATA1	DATA1	In/Output	O.D	16	INIT	INIT	In/Output	O.D/T.S <sup>*1</sup>
4	DATA2	DATA2	In/Output	O.D	17	SLCTIN	ADSTRB	In/Output	O.D/T.S <sup>*1</sup>
5	DATA3	DATA3	In/Output	O.D	18	GND	GND		
6	DATA4	DATA4	In/Output	O.D	19	GND	GND		
7	DATA5	DATA5	In/Output	O.D	20	GND	GND		
8	DATA6	DATA6	In/Output	O.D	21	GND	GND		
9	DATA7	DATA7	In/Output	O.D	22	GND	GND		
10	ACKNLG	ACKNLG	Input	TTL	23	GND	GND		
11	BUSY	WAIT	Input	TTL	24	GND	GND		
12	PE	PE	Input	TTL	25	GND	GND		
13	SLCT	SLCT	Input	TTL					

*\*1 Pins 1, 14, 16 and 17 will become O.D when the SPP mode specification is used. If the mode changes to ECP or EPP, these pins will become T.S*

## ■ Keyboard / Mouse Interface

PS/2 compatible Keyboard / Mouse Interface

## ■ Ethernet Interface (10BASE-T / 100BASE-TX)

This interface complies with the IEEE802.3 Ethernet communication standard (10BASE-T / 100BASE-TX) and uses an RJ-45 type modular jack connector (8 points).

## ■ CF Card Interface

This interface accepts a CF Card, and connects to IDE.

## ■ USB Interface

This interface is for connecting USB compatible devices.

The USB port on the unit's Front face is USB Ver. 1.1 compatible. USB HUB and USB Ver. 2.0 compatible devices cannot be connected. The USB ports (2 ports) on the unit's Bottom face are USB Ver. 2.0 compatible.

## ■ PCMCIA Interface (PCMCIA)

These interfaces (2) are used to attach a PCMCIA Type II units.

## ■ Sound Interface

This interface uses 3 mini-pin jack connectors.

## ■ Expansion Unit Interface

This interface is used to attach a PCI unit.

# 5 Installation

## ■ Confirm the Installation Gasket's Positioning



- *When installing the PS-A unit, or when attaching an optional item to the PS-A unit, do not hold the PS-A unit by its rear-face fan cover while performing the work. Doing so may damage the fan cover or cause the cover to fall off.*

It is strongly recommended that you use the installation gasket.

Place the PS-A on a level surface with the display panel facing downward.

Check that the PS-A's installation gasket is seated securely into the gasket's groove, which runs around the perimeter of the panel's frame.



- *Before installing the PS-A into a cabinet or panel, check that the installation gasket is securely attached to the unit.*
- *A gasket which has been used for a long period of time may have scratches or dirt on it, and could have lost much of its water resistance. Be sure to change the gasket at least once a year, or when scratches or dirt become visible.*
- *The corresponding gasket is CA3-WPG15-01.*
- *Be sure the gasket's seam is not inserted into any of the unit's corners, only in the straight sections of the groove. Inserting it into a corner may lead to its eventually tearing.*
- *To ensure the installation gasket's maximum level of moisture resistance, be sure the gasket's seam is inserted as shown into the panel's bottom face.*

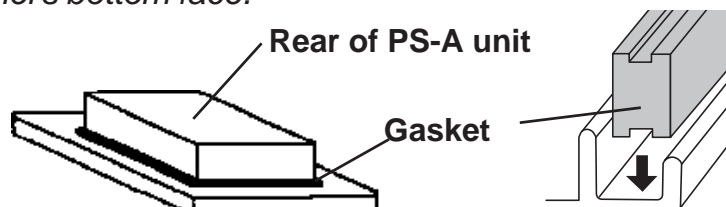

■ Create a Panel Cut

Insert the PS-A into the panel from the front.

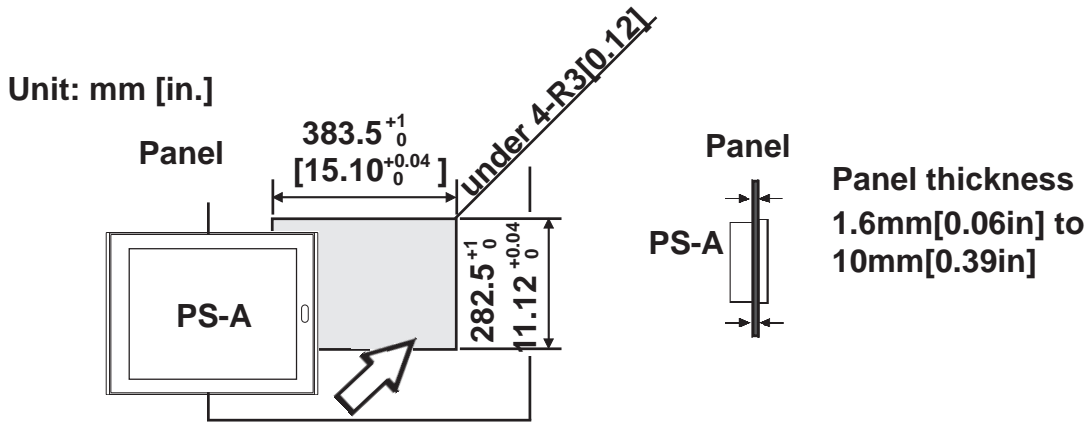

■ Attach the Installation Fasteners from Inside the Panel

The following figures show the eight (8) insertion slot locations of the PS-A installation fasteners. Insert the hook section into the slot and tighten the fastener with a screwdriver, as shown.

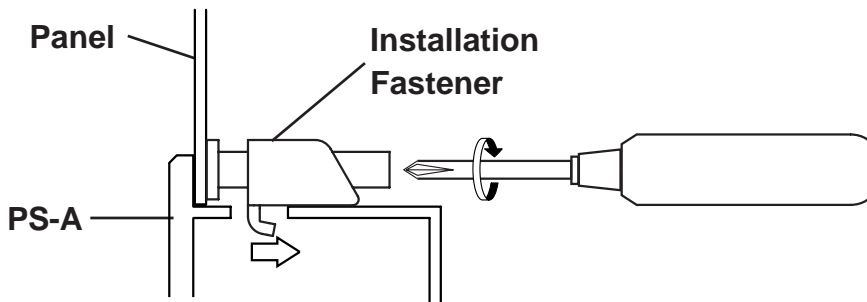
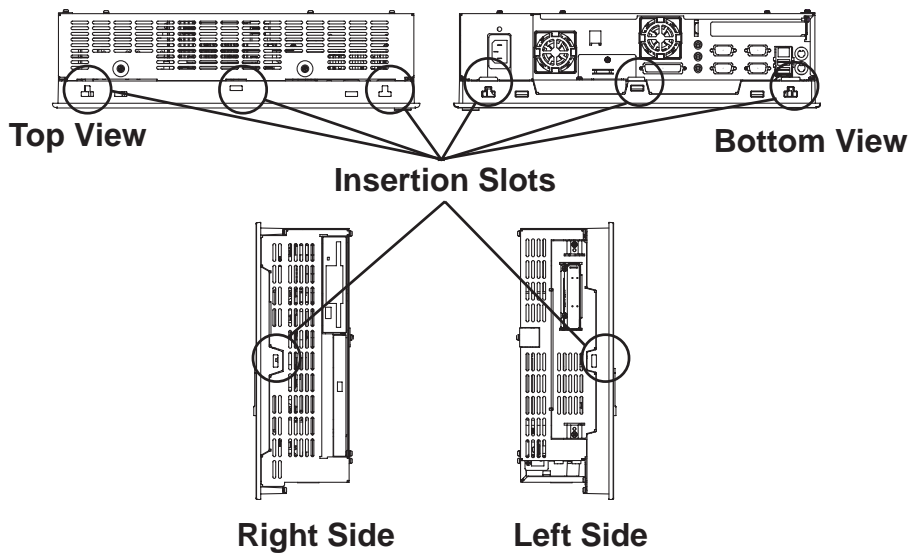

- Do not tighten the screws with too much force, since it can damage the PS-A unit.



- The torque necessary to create a drip-resistant seal is 0.5 N•m.
- Depending on the installation panel's thickness, etc., the number of installation fasteners used may need to be increased to provide the desired level of moisture resistance.

## ■ Attaching the PS-A to a VESA Arm or to the Wall

To attach the unit to an Arm or to a wall, use the attachment screws to attach a commercial-type arm or wall mount adaptor to the PS-A's rear face. (Screw hole to screw hole width: VESA 75mm)

Please refer to each device's installation guide for installation instructions.

The VESA Arm attachment screw hole dimensions are as follows;

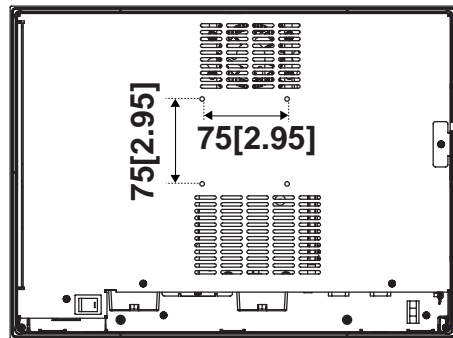

(unit: mm[in.])

Insert and tighten the four (4) M4 screws. (6mm or shorter.) The torque required for these screws is only 0.7 to 0.8 N.m.

## ■ Installation Requirements

- To enhance the PS-A's maintainability, operability and ventilation, allow at least 100 mm clearance between the PS-A and other objects. (The clearance must be large enough to allow you to install or uninstall option units and to attach connectors.)

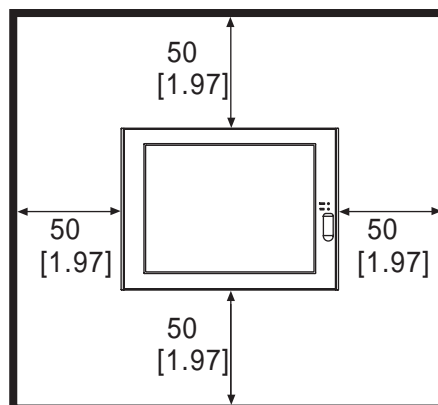
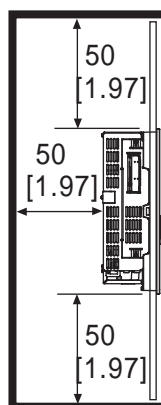

(unit: mm[in.])

- Standard installation for the PS-A unit is in a vertical panel. If the PS-A unit is to be installed in a slanted panel, the panel should not incline more than 30° from the vertical.
- If the PS-A panel is to be installed in a slanted panel that inclines more than 30°, use forced-air cooling to ensure the ambient operation temperature does not exceed 50° C.
- Horizontal installation (that is, rotating the panel so that one of its sides is the base) is not supported.

## ■ Removing and Installing the Rear Cover



- Use a screwdriver to loosen or tighten the screws. Be sure not to tighten screws too tightly, since it may damage the equipment.
- Be careful when removing or installing any screws that they do not fall inside the PS-A.

Lay the PS-A unit on its side and remove the five (5) cover attachment screws. Slide the rear cover up to remove it in the direction shown. (When reattaching the screws, use a torque of 0.5 to 0.6N•m.)

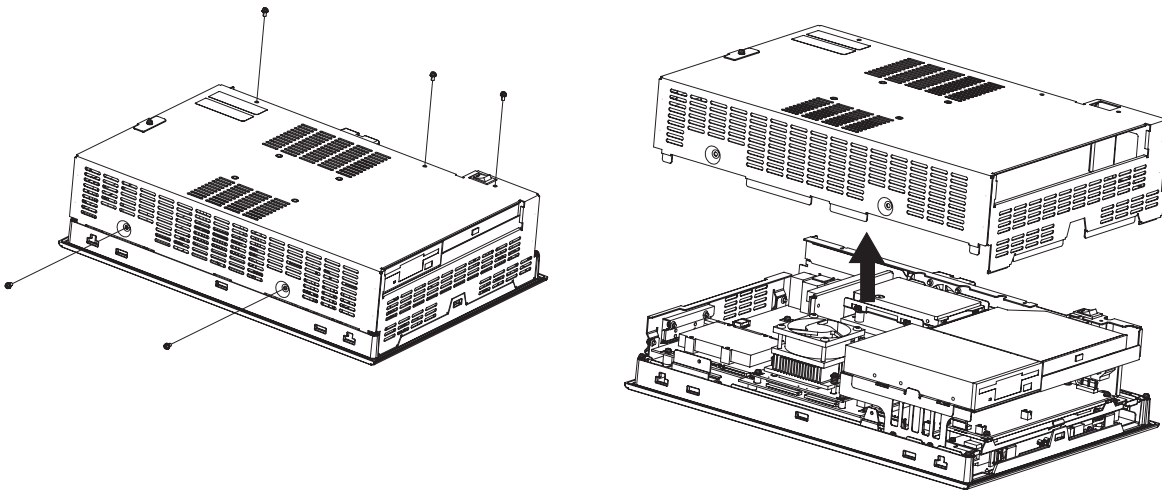

## ■ USB Cable Clamp Installation

This holder prevents the USB cable from becoming disconnected due to vibration, etc.

- 1) Place the PS-A unit face-down on a flat surface as shown below. Your PS-A unit has two USB connectors.

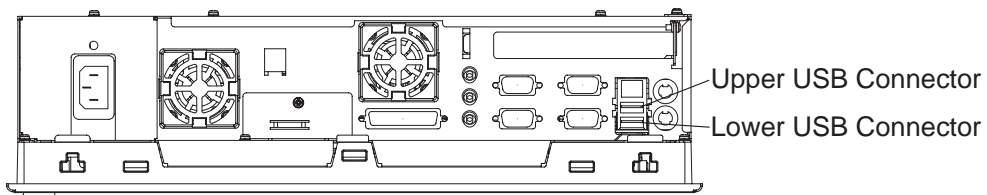

**Note:** When using only one of the USB ports, be sure to use the lower USB connector. This allows you to securely clamp the USB cable in the cable clamp.



## ◆ Attachment

As shown below, insert the USB Cable Clamp's band through the Bridge. Pass the USB cables through the Cable Clamp's band and securely tighten the clamp band around the cables.



- Be sure the clamp is securely holding the USB cable's plug and collar.
- Be sure the clamp is positioned as shown below, with the clamp pointing upwards - not to the side. This is to keep the clamp from interfering with nearby connectors and their cables.

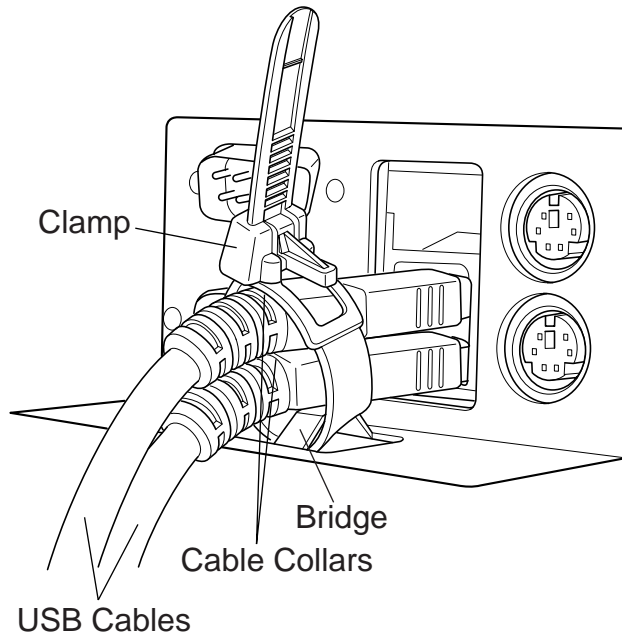

## ◆ Removal

To remove the clamp from the USB cables, push down on the clamp strap's clip to release it while pulling up on the clamp.

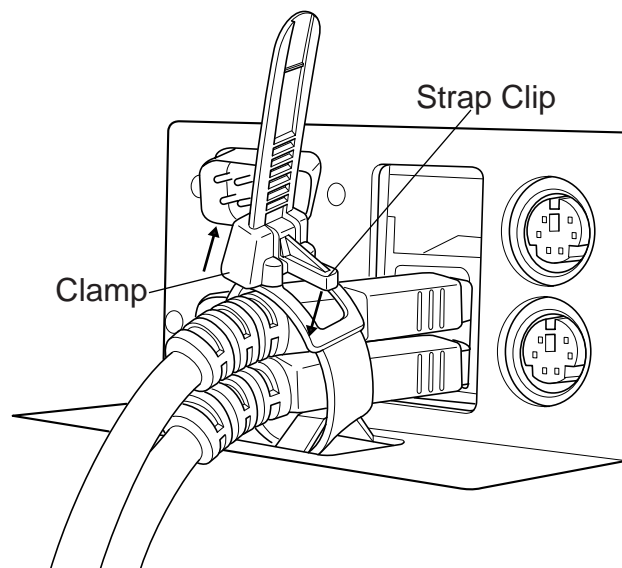

## 6 Wiring

Insert the power cord (AC inlet plug) into the PS-A's bottom face AC connector.

### WARNINGS

- To avoid an electric shock, check that the PS-A's power supply is turned OFF, via a breaker, or similar unit before connecting the PS-A's power cord to the AC connector.
- To avoid the dangers of fire, electric hazards and equipment damage, be sure to use only the specified voltage when operating the PS-A.

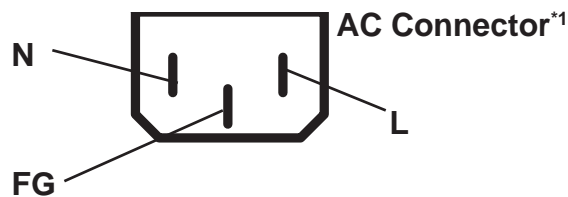

- *The Power Cord included in the PS-A unit's package is designed only for AC100V or AC115V use. Any other voltage will require a different cord.*

#### ■ Installing the AC Power Cord Clamp



- *Be sure to connect the power cord only after confirming that the PS-A unit rear face power switch is turned OFF.*

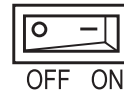

#### ◆ Attaching the AC Power Cord

- 1) Open the AC Power Cord Clamp and insert the AC Power Cord as shown in fig. 1. Then, close the Cord Clamp until it clicks into place and locks around the AC Power Cord Collar.



- **The Cord Clamp has four teeth for locking. These are to adjust the amount of grip used to hold the AC Power Cord Collar.**

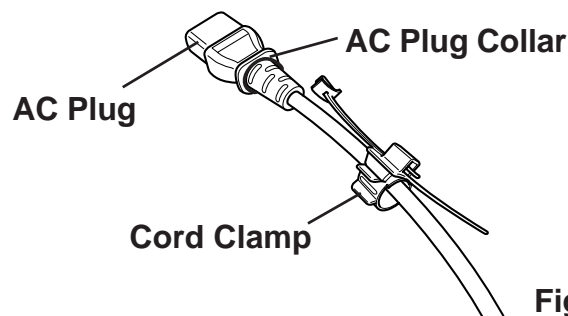

Figure 1

\*1 L : AC Input Terminal-live line

N : AC Input Terminal-neutral line

FG : Ground Terminal connected to the PS-A chassis

2) Connect the AC plug to the PS-A's AC connector, as shown in fig. 2.

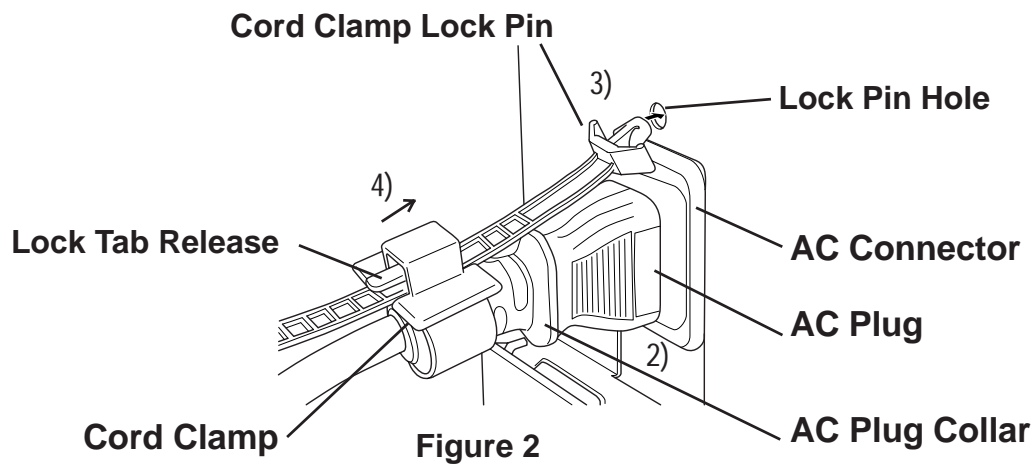

3) Insert the Cord Clamp Lock Pin into the PS-A's Lock Pin Hole.

4) Adjust the Lock Pin's Lock Tab length until it is securely held.

### ◆ Removing the AC Power Cord

1) While lifting up on the Lock Pin's Lock Tab Release, pull the AC Plug, Plug Collar and Cord Clamp backwards to disconnect it from the PS-A.

2) Open the Cord Clamp and remove the AC Power Cord from the Cord Clamp.

## 7 Power Supply Cautions

Please pay special attention to the following instructions when connecting the AC Connector to the PS-A unit.

- If the power supply voltage exceeds the PS-A unit's range, connect a voltage transformer.
- Between the line and the ground, be sure to use a low noise power supply. If there is still an excessive amount of noise, connect a noise reducing transformer.



**Note:** Be sure any constant or insulating transformer used has a capacity of 200VA or more.

- Input and Output signal lines must be separated from the power control cables for operational circuits.
- To increase the noise resistance, be sure to twist the ends of the power cord before connecting it to the PS-A unit.
- The PS-A unit's power cord should not be bundled with or kept close to main circuit lines (high voltage, high current), or input/output signal lines.
- Connect a surge absorber to handle power surges.



- *Ground the lightning surge absorber and the PS-A separately.*
- *Select a lightning surge absorber which will not exceed the allowable circuit voltage, even when the voltage rises to the maximum.*

- To reduce noise, make the power cord as short as possible.

## 8 Grounding Cautions

- When attaching a wire to the PS-A's bottom face FG terminal, (on the AC Connector), be sure to create an exclusive ground.\*<sup>1</sup>
- FG and SG terminals are internally connected in the PS-A. When connecting to another device, be sure to create an SG shorting loop in your system.

\*<sup>1</sup> Use a grounding resistance of 100Ω, a wire of 2mm<sup>2</sup> or thicker, or your country's applicable standard.

## 9 Input/Output Signal Line Cautions

- Input and Output signal lines must be separated from the power control cables for operational circuits.
- If this is not possible, use a shielded cable and the shield should be grounded.
- To improve noise immunity, it is recommended to attach a ferrite core to the power cord.

## 10 Replacing the Backlight

The PS-A unit's backlight is user replacable. For an explanation of how to replace the PS-A's backlight, please refer to the Installation Guide which comes with the replacement backlights (sold separately). The corresponding backlight is CA3-BLU15-01.



*Using any backlight other than the model written above may cause an accident or PS-A unit malfunction.*

### Note

Please be aware that Digital Electronics Corporation shall not be held liable by the user for any damages, losses, or third party claims arising from the uses of this product.