

# Preface

The PS-3700A Series Windows® XP Multi Language Preinstalled Hard Disk Unit includes an HDD drive with Microsoft corporation's preinstalled Windows® XP operating system, as well as other driver and utility software. These items are used when operating Pro-face's Compact Panel Computer PS-3700A Series unit, hereafter referred to collectively as the "PS-A".

Corresponding models: PS-3700A Series units

The following trade names are registered trademarks of the following companies.

Pro-face® : Digital Electronics Corporation (in Japan and other countries)

Windows® XP : Microsoft® Corporation

Symantec Ghost™ : Symantec Corporation

## **IMPORTANT - Read Prior to Opening and Operating**

This HDD unit contains a preinstalled version of Windows® XP Professional. Be sure to read and agree to all conditions stated herein prior to using this product. If you do not agree to all the conditions stated in this agreement, please return the entire product.

COA Data

*\* This Installation Guide is an important part of this product. Be sure to keep it in an easy-to-find location.*

# Microsoft® Windows® XP Professional for Embedded Systems

## End User License Agreement

- You have acquired a device (“DEVICE”) that includes software licensed by Digital Electronics Corporation from an affiliate of Microsoft Corporation (“MS”). Those installed software products of MS origin, as well as associated media, printed materials, and “online” or electronic documentation (“SOFTWARE”) are protected by international intellectual property laws and treaties. Manufacturer, MS and its suppliers (including Microsoft Corporation) own the title, copyright, and other intellectual property rights in the SOFTWARE. The SOFTWARE is licensed, not sold. All rights reserved.
- This EULA is valid and grants the end-user rights ONLY if the SOFTWARE is genuine and a genuine Certificate of Authenticity for the SOFTWARE is included. For more information on identifying whether your software is genuine, please see <http://www.microsoft.com/piracy/howtotell>.
- IF YOU DO NOT AGREE TO THIS END USER LICENSE AGREEMENT (“EULA”), DO NOT USE THE DEVICE OR COPY THE SOFTWARE. INSTEAD, PROMPTLY CONTACT Digital Electronics Corporation FOR INSTRUCTIONS ON RETURN OF THE UNUSED DEVICE(S) FOR A REFUND. **ANY USE OF THE SOFTWARE, INCLUDING BUT NOT LIMITED TO USE ON THE DEVICE, WILL CONSTITUTE YOUR AGREEMENT TO THIS EULA (OR RATIFICATION OF ANY PREVIOUS CONSENT).**
- **GRANT OF SOFTWARE LICENSE.** This EULA grants you the following license:
  - You may use the SOFTWARE only on the DEVICE.
  - **Restricted Functionality.** You are licensed to use the SOFTWARE to provide only the limited functionality (specific tasks or processes) for which the DEVICE has been designed and marketed by *Digital Electronics Corporation*. This license specifically prohibits any other use of the software programs or functions, or inclusion of additional software programs or functions that do not directly support the limited functionality on the DEVICE. Notwithstanding the foregoing, you may install or enable on a DEVICE, systems utilities, resource management or similar software solely for the purpose of administration, performance enhancement and/or preventive maintenance of the DEVICE.
  - If you use the DEVICE to access or utilize the services or functionality of Microsoft Windows Server products (such as Microsoft Windows Server 2003), or use the DEVICE to permit workstation or computing devices to access or utilize the services or functionality of Microsoft Windows Server products, you may be required to obtain a Client Access License for the DEVICE and/or each such workstation or computing device. Please refer to the end user license agreement for your Microsoft Windows Server product for additional information.
  - **NOT FAULT TOLERANT.** THE SOFTWARE IS NOT FAULT TOLERANT. *Digital Electronics Corporation* HAS INDEPENDENTLY DETERMINED HOW TO USE THE SOFTWARE IN THE DEVICE, AND MS HAS RELIED UPON *Digital Electronics Corporation* TO CONDUCT SUFFICIENT TESTING TO DETERMINE THAT THE SOFTWARE IS SUITABLE FOR SUCH USE.
  - **NO WARRANTIES FOR THE SOFTWARE.** THE SOFTWARE is provided “AS IS” and with all faults. THE ENTIRE RISK AS TO SATISFACTORY QUALITY, PERFORMANCE, ACCURACY, AND EFFORT (INCLUDING LACK OF NEGLIGENCE) IS WITH YOU. ALSO, THERE IS NO WARRANTY AGAINST INTERFERENCE WITH YOUR ENJOYMENT OF THE SOFTWARE OR AGAINST INFRINGEMENT. **IF YOU HAVE RECEIVED ANY WARRANTIES REGARDING THE DEVICE OR THE SOFTWARE, THOSE WARRANTIES DO NOT ORIGINATE FROM, AND ARE NOT BINDING ON, MS.**
  - **No Liability for Certain Damages.** EXCEPT AS PROHIBITED BY LAW, MS SHALL HAVE NO LIABILITY FOR ANY INDIRECT, SPECIAL, CONSEQUENTIAL OR INCIDENTAL DAMAGES ARISING FROM OR IN CONNECTION WITH THE USE OR PERFORMANCE OF THE SOFTWARE. THIS LIMITATION SHALL APPLY EVEN IF ANY REMEDY FAILS OF ITS ESSENTIAL PURPOSE. IN NO EVENT SHALL MS BE LIABLE FOR ANY AMOUNT IN EXCESS OF U.S. TWO HUNDRED FIFTY DOLLARS (U.S.\$250.00).

- **Restricted Uses.** The SOFTWARE is not designed or intended for use or resale in hazardous environments requiring fail-safe performance, such as in the operation of nuclear facilities, aircraft navigation or communication systems, air traffic control, or other devices or systems in which a malfunction of the SOFTWARE would result in foreseeable risk of injury or death to the operator of the device or system, or to others.
- **Limitations on Reverse Engineering, Decompilation, and Disassembly.** You may not reverse engineer, decompile, or disassemble the SOFTWARE, except and only to the extent that such activity is expressly permitted by applicable law notwithstanding this limitation.
- **SOFTWARE as a Component of the DEVICE - Transfer.** This license may not be shared, transferred to or used concurrently on different computers. The SOFTWARE is licensed with the DEVICE as a single integrated product and may only be used with the DEVICE. If the SOFTWARE is not accompanied by a DEVICE, you may not use the SOFTWARE. You may permanently transfer all of your rights under this EULA only as part of a permanent sale or transfer of the DEVICE, provided you retain no copies of the SOFTWARE. If the SOFTWARE is an upgrade, any transfer must also include all prior versions of the SOFTWARE. This transfer must also include the Certificate of Authenticity label. The transfer may not be an indirect transfer, such as a consignment. Prior to the transfer, the end user receiving the SOFTWARE must agree to all the EULA terms.
- **Consent to Use of Data.** You agree that MS, Microsoft Corporation and their affiliates may collect and use technical information gathered in any manner as part of product support services related to the SOFTWARE. MS, Microsoft Corporation and their affiliates may use this information solely to improve their products or to provide customized services or technologies to you. MS, Microsoft Corporation and their affiliates may disclose this information to others, but not in a form that personally identifies you.
- **Internet Gaming/Update Features.** If the SOFTWARE provides, and you choose to utilize, the Internet gaming or update features within the SOFTWARE, it is necessary to use certain computer system, hardware, and software information to implement the features. By using these features, you explicitly authorize MS, Microsoft Corporation and/or their designated agent to use this information solely to improve their products or to provide customized services or technologies to you. MS or Microsoft Corporation may disclose this information to others, but not in a form that personally identifies you.
- **Internet-Based Services Components.** The SOFTWARE may contain components that enable and facilitate the use of certain Internet-based services. You acknowledge and agree that MS, Microsoft Corporation or their affiliates may automatically check the version of the SOFTWARE and/or its components that you are utilizing and may provide upgrades or supplements to the SOFTWARE that may be automatically downloaded to your DEVICE. Microsoft Corporation or their affiliates do not use these features to collect any information that will be used to identify you or contact you. For more information about these features, please see the privacy statement at <http://go.microsoft.com/fwlink/?LinkId=25243>.
- **Links to Third Party Sites.** You may link to third party sites through the use of the SOFTWARE. The third party sites are not under the control of MS or Microsoft Corporation, and MS or Microsoft are not responsible for the contents of any third party sites, any links contained in third party sites, or any changes or updates to third party sites. MS or Microsoft Corporation is not responsible for webcasting or any other form of transmission received from any third party sites. MS or Microsoft Corporation are providing these links to third party sites to you only as a convenience, and the inclusion of any link does not imply an endorsement by MS or Microsoft Corporation of the third party site.
- **Notice Regarding Security.** To help protect against breaches of security and malicious software, periodically back up your data and system information, use security features such as firewalls, and install and use security updates.
- **No Rental/Commercial Hosting.** You may not rent, lease, lend or provide commercial hosting services with the SOFTWARE to others.
- **Separation of Components.** The SOFTWARE is licensed as a single product. Its component parts may not be separated for use on more than one computer.

- **Additional Software/Services.** This EULA applies to updates, supplements, add-on components, product support services, or Internet-based services components (“Supplemental Components”), of the SOFTWARE that you may obtain from *Digital Electronics Corporation*, MS, Microsoft Corporation or their subsidiaries after the date you obtain your initial copy of the SOFTWARE, unless you accept updated terms or another agreement governs. If other terms are not provided along with such Supplemental Components and the Supplemental Components are provided to you by MS, Microsoft Corporation or their subsidiaries then you will be licensed by such entity under the same terms and conditions of this EULA, except that (i) MS, Microsoft Corporation or their subsidiaries providing the Supplemental Components will be the licensor with respect to such Supplemental Components in lieu of the “COMPANY” for the purposes of the EULA, and (ii) TO THE MAXIMUM EXTENT PERMITTED BY APPLICABLE LAW, THE SUPPLEMENTAL COMPONENTS AND ANY (IF ANY) SUPPORT SERVICES RELATED TO THE SUPPLEMENTAL COMPONENTS ARE PROVIDED AS IS AND WITH ALL FAULTS. ALL OTHER DISCLAIMERS, LIMITATION OF DAMAGES, AND SPECIAL PROVISIONS PROVIDED BELOW AND/OR OTHERWISE WITH THE SOFTWARE SHALL APPLY TO SUCH SUPPLEMENTAL COMPONENTS. MS, Microsoft Corporation or their subsidiaries reserve the right to discontinue any Internet-based services provided to you or made available to you through the use of the SOFTWARE.
- **Recovery Media.** If SOFTWARE is provided by *Digital Electronics Corporation* on separate media and labeled “Recovery Media” you may use the Recovery Media solely to restore or reinstall the SOFTWARE originally installed on the DEVICE.
- **Backup Copy.** You may make one (1) backup copy of the SOFTWARE. You may use this backup copy solely for your archival purposes and to reinstall the SOFTWARE on the DEVICE. Except as expressly provided in this EULA or by local law, you may not otherwise make copies of the SOFTWARE, including the printed materials accompanying the SOFTWARE. You may not loan, rent, lend or otherwise transfer the backup copy to another user.
- **End User Proof of License.** If you acquired the SOFTWARE on a DEVICE, or on a compact disc or other media, a genuine Microsoft “Proof of License”/Certificate of Authenticity label with a genuine copy of the SOFTWARE identifies a licensed copy of the SOFTWARE. To be valid, the label must be affixed to the DEVICE, or appear on *Digital Electronics Corporation*’s software packaging. If you receive the label separately other than from *Digital Electronics Corporation*, it is invalid. You should keep the label on the DEVICE or packaging to prove that you are licensed to use the SOFTWARE.
- **Product Support.** Product support for the SOFTWARE is not provided by MS, Microsoft Corporation, or their affiliates or subsidiaries. For product support, please refer to *Digital Electronics Corporation* support number provided in the documentation for the DEVICE. Should you have any questions concerning this EULA, or if you desire to contact *Digital Electronics Corporation* for any other reason, please refer to the address provided in the documentation for the DEVICE.
- **Termination.** Without prejudice to any other rights, *Digital Electronics Corporation* may terminate this EULA if you fail to comply with the terms and conditions of this EULA. In such event, you must destroy all copies of the SOFTWARE and all of its component parts.
- **EXPORT RESTRICTIONS.** You acknowledge that SOFTWARE is subject to U.S. and European Union export jurisdiction. You agree to comply with all applicable international and national laws that apply to the SOFTWARE, including the U.S. Export Administration Regulations, as well as end-user, end-use and destination restrictions issued by U.S. and other governments. For additional information see <http://www.microsoft.com/exporting/>.
- No Office Automation and Personal Computing Functions may run locally on the Embedded System, except for network/Internet browsing functionality;
- A maximum of ten (10) computers or other electronic devices may connect to the Embedded System to access and use services of the Licensed Product solely for file and print services, internet information services, or remote access (including connection sharing and telephone services). The ten-connection maximum includes any indirect connections made through “multiplexing”, or other software or hardware which pools or aggregates connections.
- **Microsoft® Windows® Preinstallation Environment Only**
  - Software. You may install, use, access, display and run one (1) copy of the SOFTWARE on the DEVICE only as a boot, diagnostic, setup or recovery tool for the DEVICE. You may not use the SOFTWARE as a general purpose operating system or as a substitute for an operating system product.
  - Security Feature. The SOFTWARE contains a security feature that will cause the DEVICE to reboot without prior notification to the after 24 hours of continuous use. Please take applicable precautions.

# **DMC Corporation Mouse Emulation Software (TSC-1310D/DD) Software License Agreement**

Before unsealing and using this product, please read the following license agreement carefully:

This license agreement regarding the following software product (hereinafter called “product”) is concluded between you the individual or entity licensing the product (hereinafter called (“licensee”) and DMC Co., Ltd. (hereinafter called “DMC”). With unsealing, installing, copying or using the product, the licensee is regarded to agree this contract and the contract is in force. Please confirm and understand this agreement fully in advance. If you do not agree this contract, do not unseal, install, copy or use the software product at all. In such a case, please return the product at an unused state to the place you the licensee purchased it. Your payment will be returned to the licensee.

## **1. Copyright**

The copyright of the software product belongs to Touch-Base, Ltd.

## **2. License**

For the programs included in this product and the documents related to it, DMC grants untransferable nonexclusive license to licensee, which permits use of the product under the following conditions:

- (1)When a licensee does not purchase the license which permits the licensee to use a licensed product and its copy(s) and/or the license which permits use of the product on multiple computers, the licensee is granted the right to use the product on a single computer.
- (2)The licensee can create one copy of the product for archival purposes. For the other purposes, copying the whole or part of the product is strictly prohibited whichever medium you use.
- (3)The licensee shall display the copyright notice and other necessary information which is the same as that for the product on every copy of the product.
- (4)The intangible property right of the product and its copy(s) belong to DMC or the DMC supplier.

## **3. Term of use**

This contract shall maintain its validity from conclusion of the contract to the cancellation by DMC or the licensee.

## **4. Termination of the right of use**

- (1)The licensee can at any time terminate the right to use the product by expunging or destroying the product and all the copied contents.
- (2)When a licensee contravenes these license contents, DMC can notify the licensee of termination of the right to use the product. In this case, the licensee shall return the product or all the copied contents to DMC within one month.

## 5. Limited Warranty

- (1) DMC guarantees that 90 days after the licensee purchased the product, neither material nor manufacturing flaws shall be found at the medium where the product has been recorded or stored. If any errors related to the material or manufacturing is recognized when the product is installed, we shall replace the medium used to install the product on the condition that we are notified of it within the guaranteed period.
- (2) DMC shall grant the right to use the product at a state it has been supplied without explicit or implicit guarantee except for replacement of the medium containing product described in the above clause. Further, we do not guarantee that the product is suitable as useful for the licensee's specific purpose of use and that execution of the product is neither interrupted nor an error is found at its execution.
- (3) The responsibility attributable to DMC based on this agreement is limited to replacement of the medium containing the product, and DMC shall not assume any responsibility for the explicit or implicit guarantee including the other legal warranty against a defect and a liability for reparation given from a third party to the licensee regarding the licensee's profit loss caused by the product, damage arising from a special circumstance and the damage against data or intangible property right.

## 6. Licensee's obligation

The licensee shall recognize that the product shall possess the confidential information or property information including the intangible property right protected by the Copyright Act and shall not take the following actions:

- (1) Use and copying of the product against the terms of the license and disassembling, reverse engineering, and modifying the product.
- (2) Deletion and/or change of display of the intangible property right including the copyright displayed on the medium containing the product.

## 7. Restrictions on Export

When the product is subjected to the regulation of the Foreign Exchange and Foreign Trade Control Act and the laws and regulations accompanying it and the Export, the licensee shall observe the corresponding laws and regulations and rules.



<http://www.dmccoltd.com>

Hironokougyoudanchi, Hirono-machi, Futaba-gun, Fukushima  
979-0401, Japan

Phone: +81-240-27-4030 Fax: +81-240-27-4025

## **IN-fINITY soft Keyclick32**

Digital Electronics Corporation shall be in no case liable for any loss or damages to you or any third party whatsoever arising from any faulty performance of IN-fINITY soft, nor shall be responsible to correct such error of the software program in question.

# Safety Cautions



## WARNINGS

- **Be sure to check that the PS-A unit's power is disconnected before installing the unit, in order to prevent an electrical shock.**
- **Do not attempt to modify or open the HDD unit, since it can cause a shock or fire.**
- **When installing the HDD unit, be sure to read the following "2. Installation" section's information completely to insure that the unit is correctly installed.**
- **When this HDD unit is disposed of, it should be done so according to your country's regulations for similar types of industrial waste.**

### To Prevent Accidents

- Since the HDD unit is a precision instrument, be sure it is neither hit by nor pressed strongly against another object. After unpacking, be sure the unit is not dropped or jolted during installation. Also, a PS-A unit built in to a larger unit (i.e. operation panel) should be removed and packed separately prior to shipping.
- Be sure water, liquids or metal particles are not allowed to enter the HDD unit. Any of these may cause either a breakdown or an electrical shock.
- Do not place or store this unit in a location where there is direct sunlight, excessive heat, dust or vibration.
- Do not store or operate this unit near chemicals, or where there are chemical fumes.
- Do not allow anyone other than Pro-face's own service staff to perform maintenance or adjustments to this unit.
- Do not move or shift the PS-A unit while the HDD unit is installed and the PS-A unit's power is ON.
- Do not use the HDD unit in locations where corrosive gasses are present, since they can lead to a hard disk breakdown.
- To prevent damage to file data, be sure to shut down the PS-A unit's OS before turning OFF the main power.
- To prevent HDD memory leaks, restart the OS periodically.
- In order to extend the lifetime of the hard disk, Pro-face recommends you set the Windows [Control panel]-[Power Management option]-[Turn off hard disks] selection to turn the hard disk off when the unit is not being operated. A setting of 5 minutes is recommended.

# Package Contents

Please check that the following items are all included in your package.

- Windows® XP Multi-Language

Preinstalled HDD unit (1)

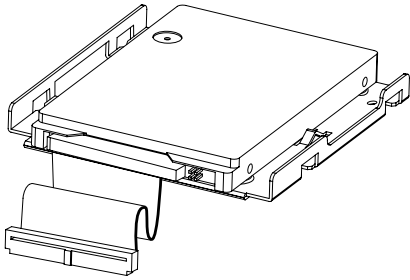

- Recovery CD (5)

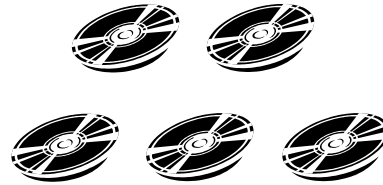

- Symantec Ghost™ EULA (1)

- Attachment Screws (4)

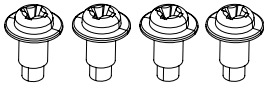

- Installation Guide (this guide)



Pro-face has taken the utmost care to ensure the quality of this product when it was shipped, however, should, for any reason, problems or damage have occurred during shipping, please contact your Pro-face representative immediately for service.



# 1 Hardware Specifications

## ■ Features

Capacity	20GB
Average Seek Time	12msec(TYP)
Power Consumption	At Startup : 4.7W (TYP)
	Read/Write : 2.0/2.1W (TYP)
	During Wait : 0.25W(TYP)
Interface	ATA
Operation Lifetime	5 years, or 20,000 operating hours, whichever comes first
Weight	Approx. 200g



- ***This HDD unit has a finite usage lifetime. Therefore, be sure to back up all HDD data periodically and/or prepare a backup HDD unit.***
- ***The HDD unit's lifetime will vary, depending on the usage conditions and environment. The above value is calculated assuming an ambient temperature of 20°C and 333 hours of operation per month. (HDD access frequency of 20% or less)***

## ■ Environment

Operating Temperature	PS-3700A	+5°C to +50°C
	PS-3701A	+5°C to +45°C
Storage Temperature		-10°C to +60°C
Ambient Humidity		10%RH to 85%RH (no condensation) (Wet bulb temperature: 29°C or less)
Noise Resistance (via Noise Simulator)		Noise Voltage: 1500Vp-p Pulse Width: 50ns, 500ns, 1μs
Electrostatic Discharge Immunity		4kV
Vibration Resistance		4.9m/s <sup>2</sup> (10Hz to 25Hz) (When Operating)
Shock Resistance		3920m/s <sup>2</sup> (1ms, Half-sine shock pulse)(When Operating)



- ***The environment specifications given here are for an HDD unit installed in a PS-A.***



- ***Pro-face does not guarantee the preservation of any data stored on the HDD unit if the HDD unit has an accident, malfunctions or is damaged in any way. Therefore, the regular backing up of important HDD unit data to either a floppy disk, or other type of suitable magnetic media is strongly recommended.***
- ***This HDD unit has a finite usage lifetime. The lifetime figure given in this document is for reference, and the periodic replacement of the current HDD unit with a new HDD unit is strongly advised.***
- ***Using the HDD unit in an environment that is excessively hot and/or humid will shorten the disk's usage lifetime. A wet bulb temperature of 29°C or less is recommended. This is equivalent to the following data.***

Temperature	Humidity
at 35°C	no higher than 64%RH
at 40°C	no higher than 44%RH

- ***In order to extend the lifetime of the hard disk, Pro-face recommends you set the Windows [Control panel]-[Power Management option]-[Turn off hard disks] selection to turn the hard disk off when the unit is not being operated. A setting of 5 minutes is recommended.***

## 2 Installation

Be sure to use the following installation procedures to insure that the HDD unit is correctly installed. The Installation location will differ, depending on the type of PS-A unit you are using.



### WARNING

**Shock Danger! Be sure to disconnect the PS-A unit from its power supply prior to installing the HDD unit.**



- *Since the HDD unit is a precision instrument that has a low resistance to shocks, be sure it is neither hit by nor pressed strongly against another object when installing it.*

#### ■ When using PS-3700A (Pentium® 4 - 1.7GHz Model)/PS-3700A (Eden™ 6000 - 667MHz Model) unit

The following procedure uses a PS-3700A(Pentium® 4 - 1.7GHz Model) unit as an example.

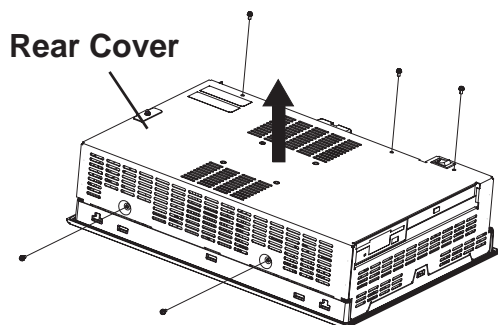

1) Place the PS-A unit face down and unscrew five (5) cover attachment screws. (See diagram)

2) lift the Rear Cover off of the PS-A unit.

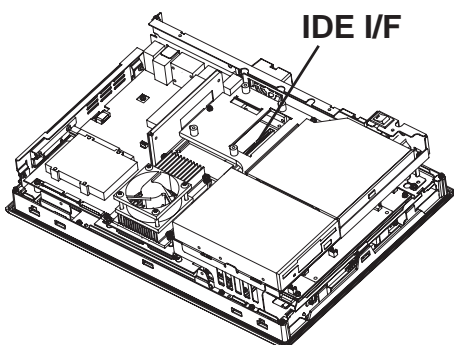

3) Insert the HDD unit's cable connector completely into the IDE I/F.

4) Attach the HDD unit using the four (4) attachment screws. (See diagram) The torque should be 0.5 to 0.6 N•m.

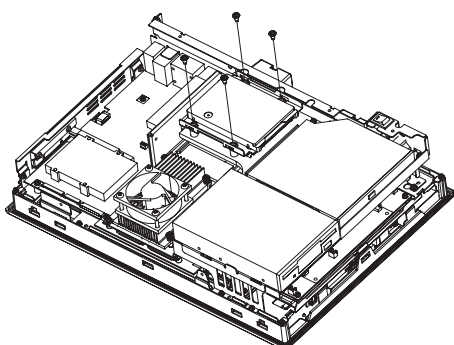

5) Replace the PS-A unit's cover and reattach five (5) attachment screws. The torque should be 0.5 to 0.6 N•m.

■ When using PS-3701A(Eden™ 6000 - 667MHz Model) unit

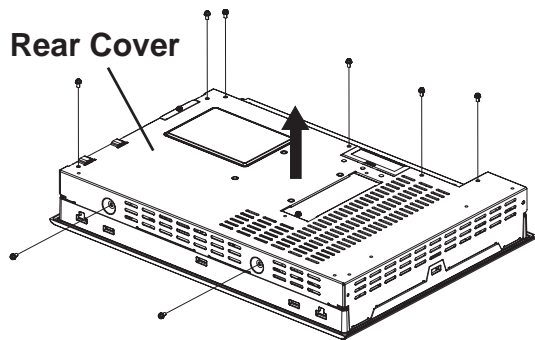

1) Place the PS-A unit face down and unscrew eight (8) cover attachment screws.

2) Lift the Rear Cover off of the PS-A unit.

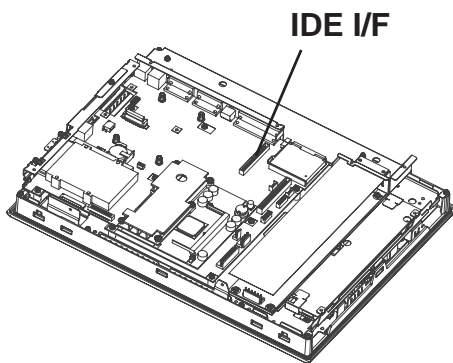

3) Insert the HDD unit's cable connector completely into the IDE I/F.

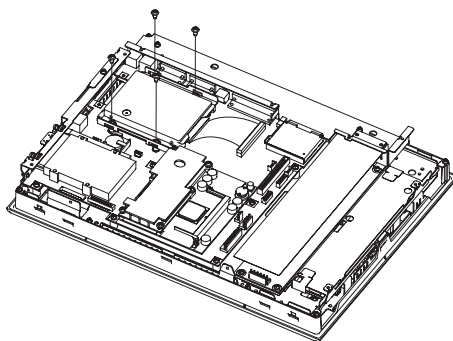

4) Attach the HDD unit using the four (4) attachment screws. (See diagram) The torque should be 0.5 to 0.6 N•m.

5) Replace the PS-A unit's Rear Cover and reattach eight (8) attachment screws. The torque should be 0.5 to 0.6 N•m.

## 3

# Hardware Setup



- *Normally, the factory default settings should be used.*
- *Certain BIOS screen items may differ from those shown here due to new versions or the PS-A unit you are using.*
- *The following explanation uses the PS-A unit's factory settings.*

The HDD unit's installation and system data settings are as follows.

- 1) Install the HDD unit in the PS-A. Refer to **2 Installation** for details. If the HDD unit is already installed, this step is not necessary.
- 2) Connect a keyboard to the PS-A.
- 3) Turn on the PS-A unit's power supply and use the following steps to set up the system data and recognize the HDD unit.
- 4) When the start-up screen appears, press your Keyboard's [DEL] key.

The Setup utility will start. Select [Standard CMOS Features], then select [IDE Primary Master]. The following screen will appear.

Phoenix - AwardBIOS CMOS Setup Utility		Item Help
IDE Primary Master		Menu Level ▶▶
IDE HDD Auto-Detection	[Press Enter]	To auto-detect the HDD's size, head... on this channel
IDE Primary Master	[Auto]	
Access Mode	[Auto]	
Capacity	0 MB	
Cylinder	0	
Head	0	
Precomp	0	
Landing Zone	0	
Sector	0	

↑↓←→:Move Enter:Select +/-/PU/PD:Value F10:Save ESC:Exit F1:General Help  
 F5: Previous Values F6: Fail-Safe Defaults F7: Optimized Defaults

- 5) Confirm whether "AUTO" is selected for IDE Primary Master. Also, confirm whether "AUTO" is selected for the [Access Mode]. If AUTO is not selected, change these settings to AUTO with the + or - key. If AUTO is selected in both, disk parameters will be automatically read when the PS-A is turned ON. The factory setting is AUTO and recommended for most users.
- 6) After all changes are made, press the ESC key and select [Save & EXIT Setup] to save the settings. The OS will then start.

## ■ Software Included

Your Windows® XP Multi Language preinstalled hard disk unit contains the following software.

- Microsoft corporation's Windows® XP Professional for Embedded OS
- Pro-face's PS-A utility software and drivers
- DMC Corporation's Mouse Emulation Software (TSC-1310D/DD)
- IN-fINITY soft's Keyboard Emulation Software KeyClick32

## ■ Windows® XP Setup Procedure

The Windows® XP Setup Procedure will be described below. The setting items differ depending on a user's environment. Please check with your network manager and make correct settings.



- **A detailed explanation of the software included, as well as a list of the revisions made after the printing of this document can be found in the HDD unit's README.txt file. Be sure to see it before work.**
- **A keyboard is required in order to set up OS.**

- 1) Once the power of the PS-A unit with Windows® XP preinstalled is turned ON, the [Welcome to Microsoft Windows] screen will appear. Click on [Next].
- 2) The [The End User License Agreement] screen will appear.  
After reading the contents, press [Yes, I accept] if you agree, and click [Next] to continue.
- 3) The [Help protect your PC] screen will appear. Choose whether to update Windows® automatically. To enable the Automatic Updates, check on [Help protect my PC by turning on Automatic Updates now (recommended)]. To disable it, check [Not right now]. Click [Next] to continue.
- 4) The [What's your computer's name?] screen will appear.  
After entering the computer's name, click [Next] to continue. At default, the computer's name has been entered. If it's not necessary to change it, click [Skip].
- 5) The [What's your Administrator password?] screen will appear. If the password is set, enter the password in [Administrator password:] and [Confirm password:] and click [Next]. If the password is not set, click [Skip].
- 6) The [Is this computer in a domain?] screen will appear. To join the domain, select [Yes, make this computer a member of the following domain:] and enter the domain's name. Not to join the domain, click [Next] to continue.

- 7) The [Checking your internet connectivity?] screen will appear and your internet connectivity will be automatically checked.
- 8) The [Ready to register with Microsoft?] screen will appear.  
If you register, check [Yes, I'd like to register with Microsoft now].  
If not, check [No, not at this time]. Press [Next].
- 9) The [Who will use this computer?] will appear. Up to 5 names can be entered for a user's name. After entering the user's name, click [Next] to continue.
- 10) The [Thank you!] screen will appear. Click [Finish] to complete the setting.



As for how to change BIOS Setting, refer to the PS-3700A Series User Manual. After changing the BIOS, restart the Windows® and make the setting following the instructions shown on the screen.

## 5 The Languages

The Windows® XP Multi Language Preinstalled Hard Disk Unit contains the following languages;

Chinese (Simplified)	French	Portuguese (Brazil)	Estonian
Chinese (Traditional)	German	Russian	Latvian
Czech	Greek	Spanish	Lithuanian
Danish	Hungarian	Swedish	Romanian
Dutch	Italian	Turkish	Slovak
English	Polish	Bulgarian	Slovenian
Finnish	Portuguese	Croatian	Thai

### ■ Designating the Language

- 1) Select the Windows® XP [Start] menu's [Control Panel].
- 2) Select [Date, Time, Language, and Regional Options] in the Control Panel and then the [Regional and Language Options] command.
- 3) Select the appropriate language from "Language used in menus and dialogs" in the [Languages] tab.

## 6 HDD Recovery Procedure



- ***After performing hard disk recovery, the PS-A unit's hard disk is returned to its factory shipped condition.***
- ***For recovery, the following things are required;  
The PS-A unit, HDD to be recovered, a CD-ROM drive (PSS-CD01 or a commercial USB-type CD-ROM drive), and a PS/2 keyboard.***

Use the following steps used to recover the Windows® XP Multi-Language Preinstalled Hard Disk.

1. Insert the Recovery CD's Disk 1 into the CD-ROM drive and turn the PS-A unit's power ON. Immediately after the power turns ON, keep pressing the [Del] key. The unit's BIOS setup screen will appear.
2. Select [CDROM] for [First Boot Device] of [Advanced BIOS Features].  
(When using a commercial USB-type CD-ROM drive, select [USB-CDROM] for [First Boot Device].)
3. Press the [F10] key to save the setting and restart the PS-A unit.
4. After the PS-A unit restarts, the Symantec Ghost™ will automatically start.
5. After the Symantec Ghost™ starts, the [Question] dialog box will appear.  
"Partition sizes correct?"
6. The volume displayed in New Size will be recovered. After confirming it, press the [Yes] button. To change it, press the [No] button and go to the [Destination Drive Details] dialog box. In the [Destination Drive Details] dialog box, change the size of the New Size and press the [OK] button.
7. The [Question] dialog box will appear. Press the [Yes] button. It will be reconfirmed that the data of the hard disk is all reset to the original values at the time of delivery.  
"Proceed with disk restore?  
Destination drive will be permanently overwritten."
8. The Recovery CD's Disk 1's hard disk recovery program will start. After a while, the [Span Volume [1] Done] dialog box will appear. Replace the Recovery CD's Disk 1 in the CD-ROM drive with the Recovery CD Disk 2 and press the [OK] button. Follow the same step for the Recovery CD Disk 3 and press the [OK] button.



9. After the recovery operation finishes, Symantec Ghost™ finishes and the following message will appear.  
After the message appears, turn off the power supply of the unit.  
"Please turn off the computer."
10. After turning on the power supply once again, push the [DEL] key to go to the BIOS Setup Screen.
11. In the Setup screen, set Load Optimized Defaults to reset all BIOS settings to their original values at the time of delivery. Press the [F10] key to save the settings and restart the unit.
12. After the unit restarts, set up your OS.

**Reference** *4 OS Setup*



- ***If the hard disk unit breaks down due to a hardware problem, (Ex. if BIOS cannot find the hard disk, if the hard disk's lifetime expires, or it breaks down), Symantec Ghost™ cannot recover the hard disk. Pro-face recommends that in this case you contact your local PS-A distributor for instructions about hard disk recovery or replacement.***
- ***Pro-face does not guarantee the preservation of any data stored on the HDD unit if the HDD unit has an accident, malfunctions or is damaged in any way. Therefore, the regular backing up of important HDD unit data to either floppy disks, or other type of suitable magnetic media is strongly recommended.***

**Note**

Please be aware that Digital Electronics Corporation shall not be held liable by the user for any damages, losses, or third party claims arising from the uses of this product.

Digital Electronics Corporation

8-2-52 Nanko Higashi, Suminoe-ku, Osaka 559-0031, Japan

URL: <http://www.pro-face.com/>

**Memo**

**Memo**

**Memo**