

15-inch Unit Stand (CA4-STD15-01) 15-inch Unit Power Supply (CA4-PWU15-01) Installation Guide

Thank you for purchasing Pro-face's 15-inch Unit Stand and 15-inch Unit Power Supply. These items are attached to the PS-3701A/PS-3711A unit (hereafter referred to as the PS-A.)

All product names used in this document are the trademarks of their respective manufactures.

Pro-face : Digital Electronics Corporation (in Japan and other countries)

Safety Precautions

This Installation Guide includes important safety-related information that must be followed to ensure the correct and safe use of the 15-inch Unit Stand and 15-inch Unit Power Supply. Prior to attaching either of these products, be sure to read both this Guide and any related manuals thoroughly to understand the correct operation and function of these two units.



WARNING

- Installing the 15-inch Unit Stand and 15-inch Unit Power Supply while power is supplied to the Unit may lead to an electric shock. Prior to installing the 15-inch Unit Stand and 15-inch Unit Power Supply, confirm that PS-A's power supply is disconnected.
- Prior to installing the 15-inch Unit Stand and 15-inch Unit Power Supply, read Section 3. Installation carefully.

■ To Prevent Unit Failure

- Since the Unit is a precision device, do not subject it to shocks or excessive vibration.
- Be sure that no water, liquid or metal particles are adhering to the Unit, since they can cause unit failure or an electric shock.
- Do not operate or store the Unit in locations exposed to direct sunlight, high temperatures or dust.
- Do not operate or store the Unit in locations where vaporized chemicals are present in the air, or where chemicals may contact the unit.
- Do not attempt to open or modify the Unit.
- Do not use the Unit where corrosive gasses are present.
- To prevent overheating, do not include the 15-inch Unit Cover as a built-in component of an end-user product.

■ Unit Disposal

- When the product is disposed of, it should be done so according to your country's regulations for similar types of industrial waste.

Package Contents

The 15-inch Unit Stand and 15-inch Unit Power Supply packages include the following items. Prior to using these products, please check that all their related items are present.

■ 15-inch Unit Stand (CA4-STD15-01)	■ 15-inch Unit Power Supply (CA4-PWU15-01)
•Attachment Screws (M4) :8	•Attachment Screws (M3) :4
•CD-ROM Unit Cover :1	•Power Unit Attachment Strips :2
•Hinge Angle Set Screws (M3) :2	•Power Unit Attachment Screws (M3) :8
•Installation Guide (This Guide) :1	•AC Power Cord (2m) :1
	•AC Power Cord Clamp :1
	•Cable Tie :1
	•Installation Guide (This Guide) :1

This product has been carefully packed, with special attention to quality. However, should you find anything damaged or missing, please contact your local distributor immediately.

UL/c-UL Application and CE Marking Notes

The CA4-PWU15-01 is a UL recognized component(UL File No. E250309)

The CA4-PWU15-01 conforms as a component to the following standards:

■ UL60950 Standard for Safety of Information Technology Equipment

CA4-PWU15-01(UL Registration Model No.:3382802-01)

The CA4-PWU15-01 is a CE marked, EMC compliant product.

<Complies with the following Standards>

Safety

EN60950

EMI

EN61000-6-3,EN61000-6-4,EN55011(Group1,Class A)

EMS<EN61000-6-2>

EN61000-4-2,EN61000-4-3,EN61000-4-4,EN61000-4-5,EN61000-4-6,

EN61000-4-8, EN61000-4-11

If the following requirements are not met, the 15-inch Unit Power Supply may fail to meet UL standard requirements.

- The 15-inch Unit Power Supply must be used as a built-in component of an end-use product.
- The 15-inch Unit Power Supply is designed for indoor use only.
- When connecting the 15-inch Unit Power Supply's power cord, be sure to use a cord that is appropriate for the current and voltage used and that has conductive wires that are AWG18 or larger.
- Be sure the 15-inch Unit Power Supply's enclosure is a UL60950 approved sheet steel structure.
- Be sure to use PS-A unit with the 15-inch Power Supply. Use of PS-A without the power supply can cause it to fail to meet UL standards and EN60950.

1 General Specifications

■ 15-inch Unit Power Supply (CA4-STD15-01)

Electrical Specifications	Rated Voltage	AC100V or AC240V
	Voltage Supply Range	AC85V to AC264V
	Rated Frequency	50/60Hz
	Frequency Supply Range	47Hz to 66Hz
	Power Consumption	150VA or less
	Voltage Endurance	AC1500V 20mA for 1 minute (between charging and FG terminals)
	Insulation Resistance	10MΩ or higher at DC500V (between charging and FG terminals)
Environmental Specifications	Ambient Operating Temperature	0°C to 40°C
	Storage Temperature	-10°C to +60°C
	Ambient Humidity	10%Rh to 85%RH (Non-condensing, wet bulb temperature: 29°C or less)
	Storage Humidity	10%Rh to 85%RH (Non-condensing, wet bulb temperature: 29°C or less)
	Air Purity(Dust)	Free of dust
	Pollution Degree	For use in Pollution Degree 2 environment
	Corrosive Gases	Free of corrosive gases
	Vibration Resistance	9.8m/s ² (10Hz to 25Hz)
	Noise Immunity (Impulse Noise)	Noise Voltage:1,500V Pulse Duration: 50ns,500ns,1μs Rise Time: 1ns (via noise simulator)
	Noise Immunity (First transient burst noise)	Power Line : 2kV (IEC61000-4-4) COM Port : 1kV (IEC61000-4-4)
Electrostatic Discharge Immunity	6.0kV(IEC61000-4-2)	
Structural Specifications	Grounding	100Ω or less, or your country's applicable standard
	Cooling Method	Via natural air circulation
	Weight	Approx.1.5kg (3.3lb)
	Dimensions(WxHxD)	231.0mm × 121.0mm × 42mm [9.09in. x 4.76in. x 1.65in.]

■ 15-inch Unit Stand (CA4-STD15-01)

Structural Specifications	Ratings	Installation : VESA Standard 75mm×75mm [2.95in. x 2.95in.]
	Stand Adjustment Angle	15° to 40°*1
	Weight (Approx.)	0.6kg (1.3lb)
	Dimensions (WxHxD)	257.4.0mm[10.13in]×177.5mm[6.99in]×12.7mm[0.5in]

*1 When using this stand with Hard Disk Drive Unit, be sure to adjust angles from 15° to 30°.

2

Part Names and External Dimensions

15-inch Stand Part Names

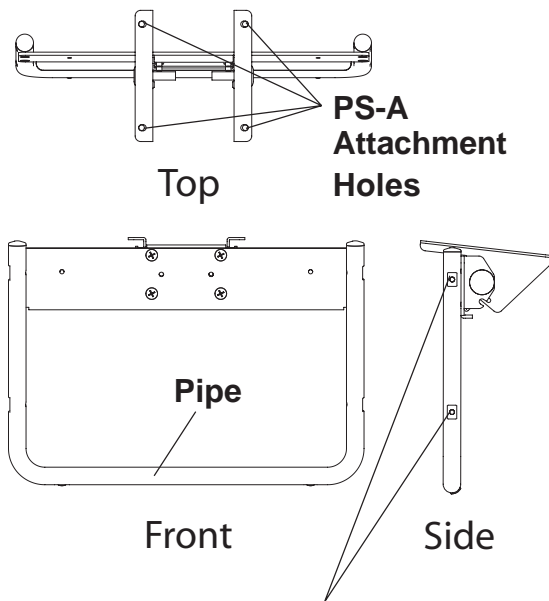

15-inch Unit Power Supply Attachment Holes

15-inch Power Supply Part Names

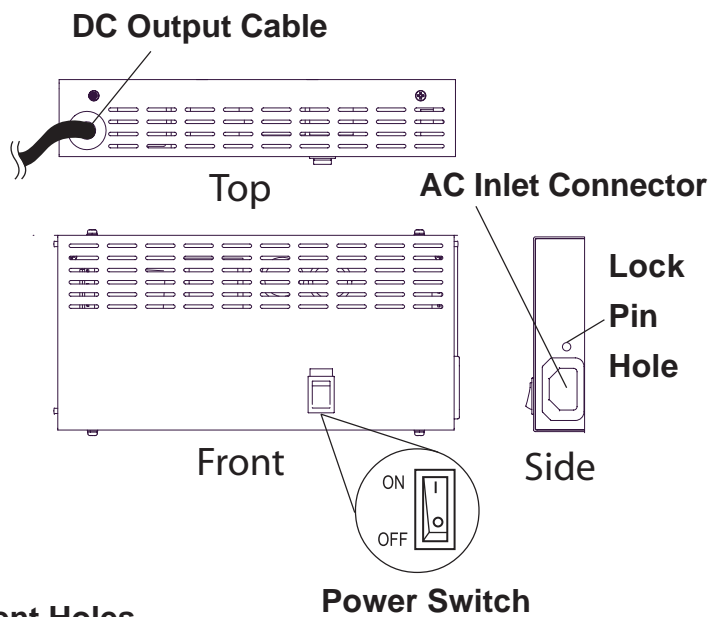

External Dimensions

The following External Dimensions are for when the 15-inch Unit Stand and the 15-inch Unit Power Supply are attached to the PS-3701A unit (same as PS-3711A unit)

Unit: mm [in.]

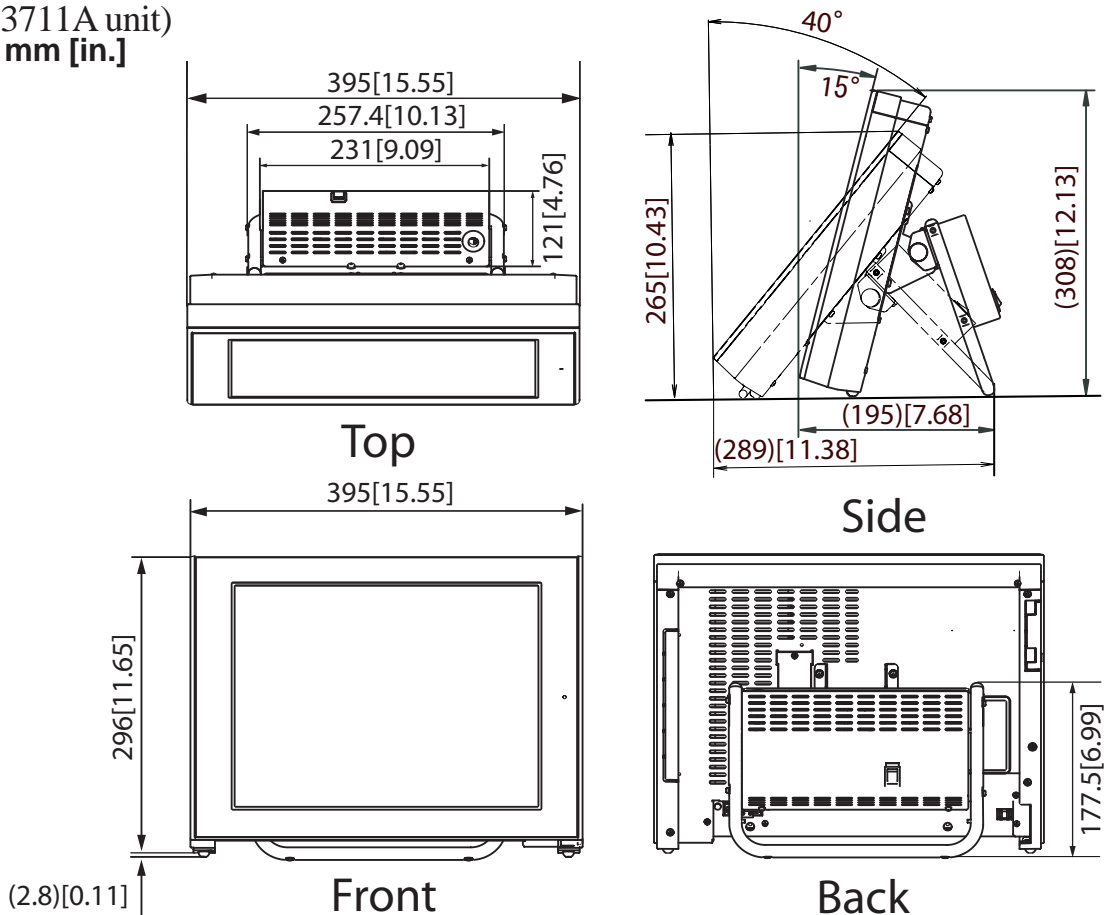

3 Installation



The 15-inch Unit Cover Set is required when using the 15-inch Unit Stand.



For 15-inch Unit Cover Set installation procedures, refer to the “15-inch Unit Cover Set Installation Guide”.

■ Attaching the 15-inch Unit Stand to the PS-3701A unit

The same procedures as PS-3711A unit.

- 1) Attach the 15-inch Unit Stand to the PS-A using the four (4) M4 attachment screws. When PS-3701A using the CD-ROM Driver Unit PSS-CD01, be sure to attach the stand to the CD-ROM Unit Cover. This cover should be oriented so its positioning notch is facing upwards. (See *1 below) (Required torque: 0.5 to 0.6 N•m.)

◆When PS-3701A using CD-ROM Drive Unit (PSS-CD01) *1

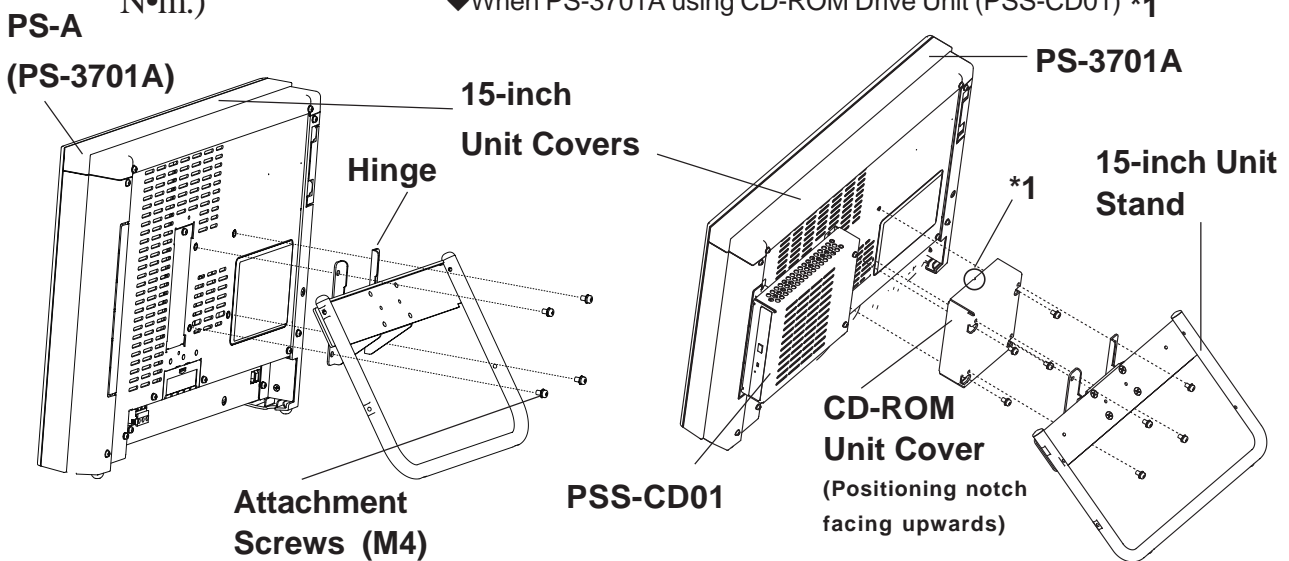

- 2) Attach the 15-inch Unit Power Supply to the 15-inch Unit Stand using the four (4) M3 attachment screws. (Required torque: 0.5 to 0.6 N•m.)

◆When PS-3701A using CD-ROM Drive Unit (PSS-CD01)

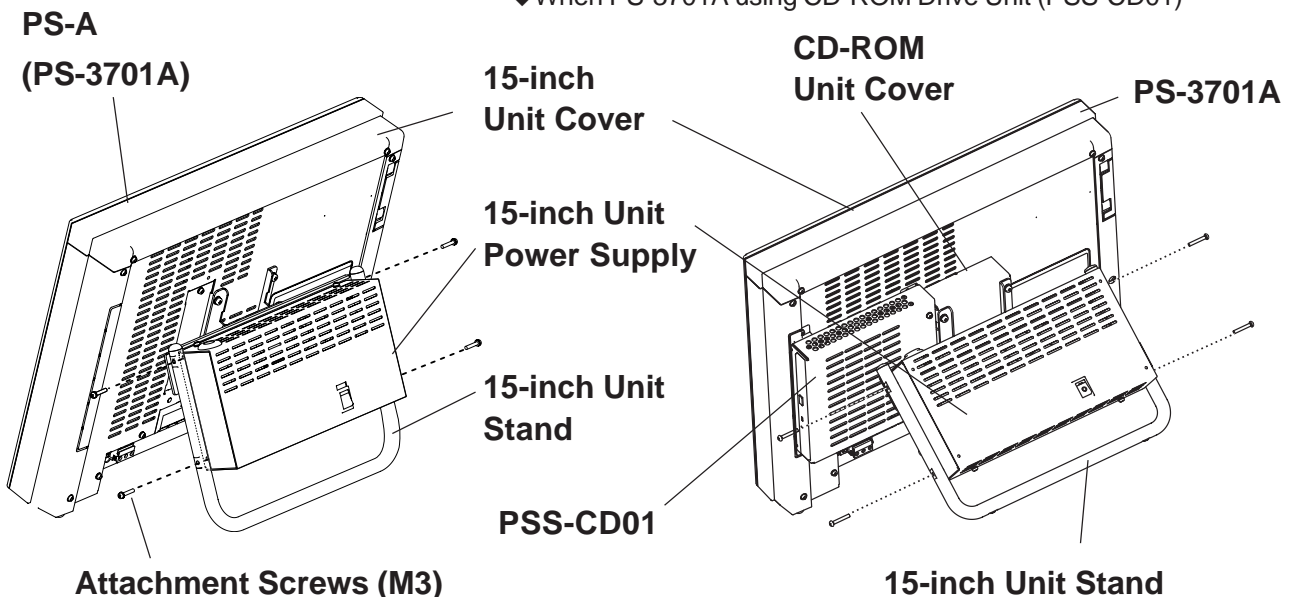

■ Attaching the 15-inch Unit Power Supply

- 1) Use four (4) Power Unit Attachment Screws to attach the Power Unit Attachment Strips to the 15-inch Unit Power Supply. Be sure to attach these strips as shown below. (Required torque: 0.5 to 0.6 N•m.)

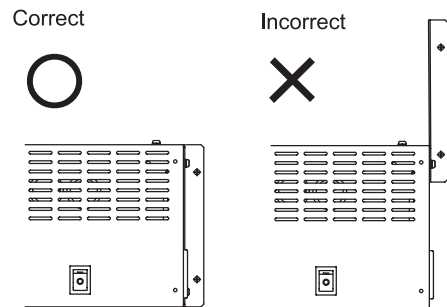
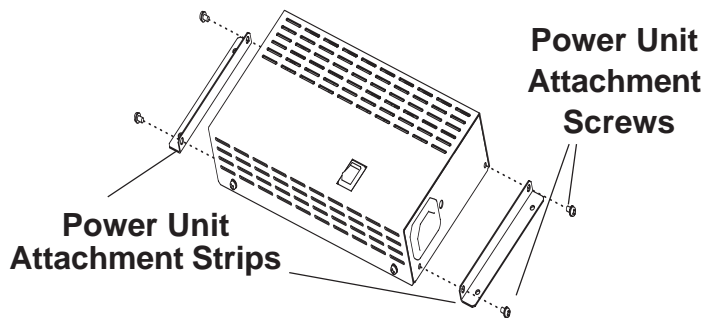

- 2) Attach the Power Supply to the Stand using the remaining Power Unit Attachment Screws. (Required torque: 0.5 to 0.6 N•m.)

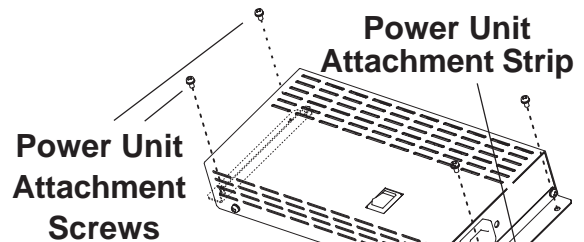

■ Fix the Stand Viewing Angle

When fixing the Stand in position, set the Stand's viewing angle at 30° and insert the Hinge Angle Set Screws as shown. (Required torque: 0.5 to 0.6 N•m.)

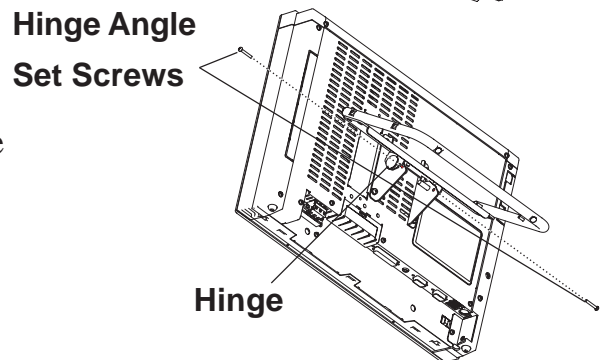

4 Wiring

■ Connecting the DC Output Cable to the PS-A

As for the wiring of the DC Output Cable to PS-A, please refer to the "Compact Panel Computer PS-3701A (Eden™ESP6000 - 667MHz Model) User Manual" for PS-3701A unit, or "PS-3710A/PS-3711A Series Hardware Manual" for PS-3711A unit.

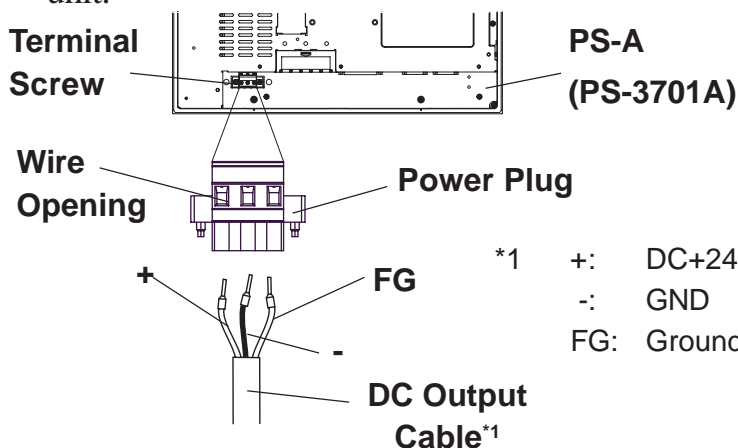

Signal	Wire Color
+	White
-	Black
FG	Green (with Yellow Spiral)

*1
 +: DC+24V
 -: GND
 FG: Ground Terminal Connected to the Power Supply

■ Connecting the AC Power Cord to the AC Connector of the 15-inch Unit Power Supply

WARNING

- To prevent an electric shock, check that the 15-inch Unit Power Supply is turned OFF before connecting the AC Power Cord to the 15-inch Unit Power Supply.
- To prevent fires, electrical hazards and equipment damage, be sure to use only the specified voltage when operating the PS-A.

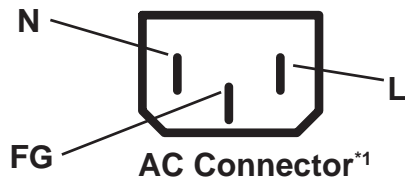

*1 L : AC Input Terminal-live line
 N : AC Input Terminal-neutral line
 FG : Ground Terminal (Connected to Power Supply)

■ Installing the AC Power Cord Clamp



Be sure to connect the power cord only after confirming that the 15-inch Unit Power Supply unit's power switch is turned OFF.

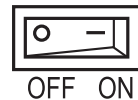

◆ Attaching the AC Power Cord

- 1) Open the AC Power Cord Clamp and insert the AC Power Cord (fig. 1). Close the Cord Clamp until it clicks into place around the AC Power Cord Collar.



Note: The Cord Clamp has four teeth for locking. These are to adjust the amount of grip used to hold the AC Power Cord Collar.

- 2) Connect the AC plug to the 15-inch Unit Power Supply's AC connector, as shown in Fig. 2.
- 3) Insert the Cord Clamp Lock Pin into the 15-inch Unit Power Supply's Lock Pin Hole.
- 4) Adjust the Lock Pin's Lock Tab length until it is securely held.

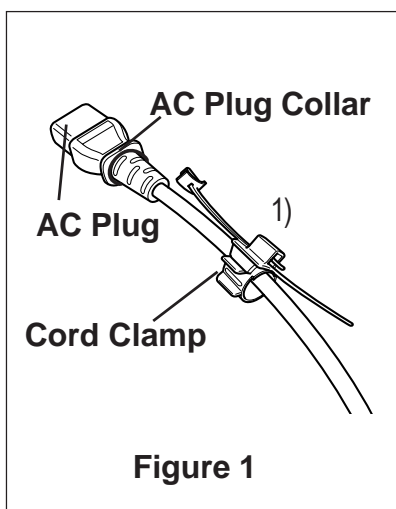

Figure 1

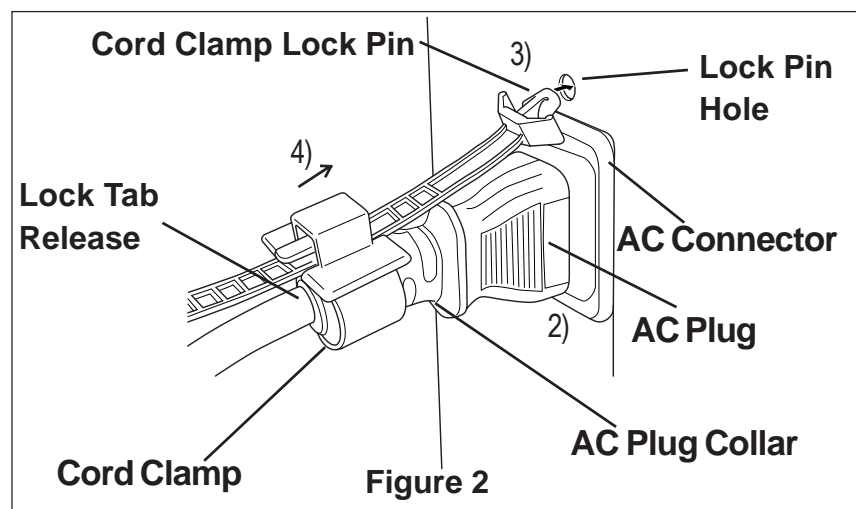

Figure 2

◆ Removing the AC Power Cord

- 1) While lifting up on the Lock Pin's Lock Tab Release, pull the AC Plug, Plug Collar and Cord Clamp backwards to disconnect it from the 15-inch Unit Power Supply.
- 2) Open the Cord Clamp and remove the AC Power Cord from the Cord Clamp.

5 Power Supply Cautions

Please pay special attention to the following instructions when connecting the AC Connector to the 15-inch Unit Power Supply.

- If the power supply voltage exceeds the 15-inch Unit Power Supply's range, connect a voltage transformer.
- Between the line and the ground, be sure to use a low noise power supply. If there is still an excessive amount of noise, connect a noise reducing transformer.



Note: Be sure any constant or insulating transformer used has a capacity of 200VA or more.

- Input and Output signal lines must be separated from the power control cables for operational circuits.
- To increase the unit's noise resistance, be sure to twist the ends of the power cord wires before connecting them to the 15-inch Unit Power Supply.
- The 15-inch Unit Power Supply's AC power cord should not be bundled with or kept close to main circuit lines (high voltage, high current), or input/output signal lines.
- Connect a surge absorber to handle power surges.



- Ground the lightning surge absorber and the 15-inch Unit Power Supply separately.
- Select a lightning surge absorber which will not exceed the allowable circuit voltage, even when the voltage rises to the maximum.
- To reduce noise, make the AC power cord as short as possible.

6 Grounding Cautions

- When attaching a wire to the 15-inch Unit Power Supply's right side FG terminal, (AC Connector), be sure to create an exclusive ground.*¹
- FG and SG terminals are internally connected in the 15-inch Unit Power Supply. When connecting to another device, be sure to create an SG shorting loop in your system.

*1 Use a grounding resistance of 100Ω, a wire of 2mm² or thicker, or your country's applicable standard.

Note

Be aware that the Digital Electronics Corporation shall not be held liable for any real or estimated damages or losses, or third party claims resulting from the use of this product.

Digital Electronics Corporation

8-2-52 Nanko Higashi, Suminoe-ku, Osaka 559-0031, Japan

URL: <http://www.pro-face.com/>