

Introduction

Thank you for purchasing Proface's PL-B900/PL-B910 series Box Type Industrial Computer, hereafter referred to as "the PL". This unit embodies Proface's latest, cost-effective architecture and is designed for Industrial Automation users.

Prior to using your PL, be sure to read this manual thoroughly to familiarize yourself with the unit's operation procedures and functions.

NOTE:

1. It is forbidden to copy the contents of this manual in whole, or in part, without the permission of the Digital Electronics Corporation.
2. The information in this manual is subject to change without notice.
3. This manual was written with care; however, if you should find any errors or omissions, please contact Digital and inform them of your findings.
- 4) Please be aware that Digital Electronics Corporation shall not be held liable by the user for any damages, losses, or third party claims arising from the uses of this product.

© Copyright 2000 Digital Electronics Corporation

MS-DOS®, Windows® 95, Windows® 98 Second Edition and Windows® NT are registered trademarks of the Microsoft Corporation.

IBM®, and DOS® are registered trademarks of IBM.

Product names used in this manual are the trademarks of their respective manufacturers.

Essential Safety Precautions

This manual includes the following cautions concerning procedures that must be followed to operate the PL correctly and safely. Prior to operating the PL, be sure to read this manual and any related materials thoroughly to understand the correct operation and functions of this unit.

Safety Icons

To allow you to use the PL correctly, throughout this manual, the following icons are provided next to operations requiring special attention. These icons are used to describe the following situations:



Indicates situations where severe bodily injury, death or major equipment damage may occur.



Indicates situations where slight bodily injury or machine damage can occur.

WARNINGS

- **To avoid the possibility of an electric shock, be sure to connect the power cord to the PL before connecting it to the main power supply.**
- **A fire or electrical shock may occur if voltages used with the PL are beyond the specified range. Be sure to use only the specified voltage.**
- **Before opening the PL's protective cover, be sure to turn the unit's power OFF. This is because the PL's internal parts carry high voltages.**
- **To avoid fires or electrical hazards, do not modify the PL in any way.**
- **Do not create touch panel switches that are used to either control or to ensure the safety of equipment and personnel. Mechanical switches, such as an emergency stop switch, a deadman (two-handed) start switch, etc., must be installed and operated via a separate control system.**



WARNINGS

- **When a problem occurs with the PL's backlight or display that causes the screen to go blank, the touch-panel may still be active, since it is a separate unit. In such a case, do not operate the touch panel, since an unexpected machine action or movement may occur, which may in turn cause machine damage or operator injury.**
- **If metal particles, water or other types of liquids contact any of the PL's internal parts, immediately turn the unit's power OFF, unplug the power cord, and contact either your PL distributor or the Digital Electronics Corporation.**
- **Read and understand Chapter 4 "Installation and Wiring" thoroughly in order to select an appropriate installation location for the PL.**
- **Before either plugging in or unplugging a board or interface connector, be sure to turn the PL's power OFF.**
- **To prevent a possible explosion, do not install the PL in areas containing flammable gases.**
- **The PL is not appropriate for use with aircraft control devices, aerospace equipment, central trunk data transmission (communication) devices, nuclear power control devices, or medical life support equipment, due to these devices' inherent requirements of extremely high levels of safety and reliability.**
- **When using the PL with transportation vehicles (trains, cars and ships), disaster and crime prevention devices, various types of safety equipment, non-life support related medical devices, etc. redundant and/or failsafe system designs should be used to ensure the proper degree of reliability and safety.**



CAUTIONS

- Avoid exposing the PL to, or operating the PL in direct sunlight, high temperatures and humidity, and in areas where excessive dust and vibration will occur.
- Avoid using the PL in areas where sudden, extreme changes in temperature can occur. This may cause condensation to form inside the unit, possibly leading to an accident.
- To prevent the PL from overheating, be sure its air circulation vents are clear and clean, and keep the unit's operation area well-ventilated.
- Avoid operating or storing the PL near chemicals, or where chemicals can come into contact with the unit.
- When the Standard display is connected to the PL, after turning the display OFF, be sure to wait at least three (3) seconds before turning it ON again.

When PL Hard Disk (HDD) data is lost:

- The Digital Electronics Corporation cannot be held responsible or provide any compensation for damage(s) caused by the loss of data stored in the PL's hard disk drive (HDD). It is therefore strongly suggested that all important data and software be backed up regularly to an external data backup device.
- Please be aware that the Digital Electronics Corporation bears no responsibility for any damages resulting from the customer's application of this unit's hardware or software.
- Since the PL unit's hard disk drive (HDD) is a consumable item, i.e. it has a limited lifetime, be sure to back up its data regularly and prepare a spare HDD unit.
- To prevent file data damage, be sure to shut down the PL's OS before turning OFF the main power.
- After turning OFF the PL's power, wait until the internal HDD stops spinning before turning on the power again (approx. 5 seconds).

Table of Contents

Introduction	1
Essential Safety Precautions	2
Table of Contents	5
Documentation Conventions	8
PL Series Model Numbers	8
Package Contents	9
Special Features	10
UL/c-UL Application Notes	11
CE Marking Notes	11

CHAPTER 1 - PL BASICS

1.1 Prior to Operating the PL	1-1
1.2 PL System Design	1-2
1.2.1 Connecting the Dual Displays	1-3
1.3 Optional Items	1-4

CHAPTER 2 - SPECIFICATIONS

2.1 General Specifications	2-1
2.1.1 Electrical	2-1
2.1.2 Structural	2-1
2.1.3 Environmental	2-2
2.2 Functional Specifications	2-3
2.2.1 General	2-3
2.2.2 Expansion Slots	2-4
2.2.3 Clock (RTC) Accuracy	2-4
2.3 Interface Specifications	2-5
2.3.1 Keyboard Interface	2-5
2.3.2 Mouse Interface	2-5
2.3.3 CRT Interface	2-5
2.3.4 RS-232C Interface (COM1/COM2/COM3)	2-6
2.3.5 Printer Interface (LPT1)	2-6
2.3.6 RAS Interface	2-7
2.3.7 USB Interface	2-8

Preface

2.4	PL Part Names and Features	2-9
2.5	PL External Dimensions	2-12
2.5.1	PL-B900/PL-B910 Unit External Dimensions	2-12
2.5.2	Installation Fasteners.....	2-13
2.5.3	Full-Sized Cover/Mirror Disk Unit Attachment Dimensions.....	2-15

CHAPTER 3 INSTALLING OPTIONAL UNITS AND EXPANSION BOARDS

3.1	Installation	3-1
3.1.1	Removing the Rear Maintenance Cover	3-2
3.1.2	Installing the DIM Module (PL-EM220 / PL-EM230).....	3-4
3.1.3	Installing the FDD Unit (PL-FD200).....	3-5
3.1.4	Installing the FDD Unit (PL-FD210).....	3-6
3.1.5	Removing/Installing the HDD unit (PL-HD2*0)	3-8
3.1.6	Installing an Expansion Board	3-9
3.1.7	Connectiong the CD-ROM unit (PL-DK200)	3-10
3.1.8	Connecting the Standard Display (DU-6900/DU-7900)	3-11
3.1.9	Installing the Display Expansion Board (PL-PE200)	3-12
3.1.10	Connecting an Analog RGB Monitor	3-13
3.1.11	Removing the Cooling Fan Unit.....	3-14

CHAPTER 4 INSTALLATION AND WIRING

4.1	Installation Cautions	4-1
4.2	Installing the PL	4-3
4.2.1	Installation Procedures.....	4-3
4.3	Wiring the PL	4-4
4.3.1	Connecting the Power Cord.....	4-4
4.3.2	Power Supply Cautions	4-6
4.3.3	Grounding Cautions.....	4-7
4.3.4	Cautions When Connecting I/O Signal Lines.....	4-7

CHAPTER 5 SYSTEM SETUP

5.1	Setup Procedures	5-1
5.2	System Parameters	5-2
5.2.1	STANDARD CMOS SETUP	5-2
5.2.2	BIOS FEATURES SETUP	5-4
5.2.3	CHIPSET FEATURES SETUP	5-6
5.2.4	POWER MANAGEMENT SETUP	5-8
5.2.5	PNP/PCI CONFIGURATION SETUP	5-10
5.2.6	LOAD BIOS DEFAULTS	5-12
5.2.7	LOAD SETUP DEFAULTS	5-12
5.2.8	SYSTEM MONITOR UTILITY	5-12
5.2.9	INTEGRATED PERIPHERALS	5-14
5.2.10	IDE HDD AUTO DETECTION SETUP	5-17

Preface

CHAPTER 6 OS SETUP

6.1	Setting Up Your PL OS	6-1
-----	-----------------------------	-----

CHAPTER 7 MAINTENANCE AND INSPECTION

7.1	Cleaning the Filter	7-1
7.2	Periodic Maintenance Points	7-3



APPENDICES

A.1	Hardware Configuration	A-1
A.1.1	I/O Mapping	A-1
A.1.2	Memory Map	A-2
A.1.3	Interrupt Map	A-3
A-2	RAS Feature	A-4
A.2.1	PL's RAS Features	A-4
A.2.2	RAS Feature Details	A-5
A.2.3	RAS Feature Overview	A-9

INDEX

Documentation Conventions

The list below describes the documentation conventions used in this manual.

Symbol	Meaning
	Indicates important information or procedures that must be followed for correct and risk-free software/device operation.
	Provides useful or important supplemental information.
*1	Indicates useful or important supplemental information.
	Refers to useful or important supplemental information
1) , 2)	Indicates steps in a procedure. Be sure to perform these steps in the order given.
PL	Abbreviation for the PL-B900 and PL-B910 Series Box Type Industrial Computers.
DU	Standard display unit for the PL-B900 and PL-B910 Series Box Type Industrial Computers.

PL Series Model Numbers

PL - B 9 * * - 4 * - ** **

A B C D E F G H I

Item	Code	Meaning
A	PL	PL Series Panel Computer
B	B	"Box" type industrial computer
C	9	PL-X900 Series unit
D	0	PL-B900 Series unit (Single display type)
	1	PL-B910 Series unit (Dual display type)
E	0	4-Slot type*1
	1	2-Slot type *1
F	4	CE Marking, UL/c-UL(CSA) Approval
G	*	PL unit's revision number
H	HU	Equipped with Hard Disk - without OS
	None	No Hard Disk
I	**	HD Revision No.
	None	No Hard Disk

*1 Refers to the number of available ISA Bus expansion slots.

Package Contents

The PL's packing box contains the items listed below. Please check to confirm that all items shown below have been included.

■ **PL Unit**

PL-B900 Series
PL-B910 Series

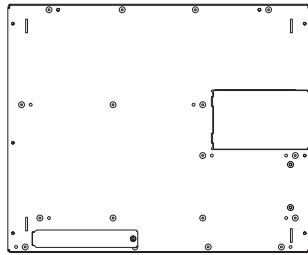

Be careful when handling the PL not to damage the built-in HDD

■ **Power Cord**

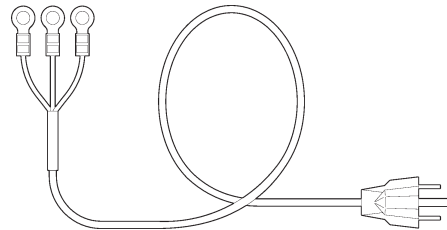

This cord is designed only for AC100/115V use. Any other voltage will require a different cord.

- **PL-B900/PL-B910 Series Box Type Industrial Computer User Manual (English)***

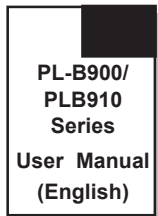

*(This manual)

- **PL-B900/PL-B910 Series Box Type Industrial Computer User Manual (Japanese)**

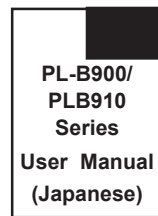

- **Installation Brackets (2 brackets - left and right) (6 attachment screws)**

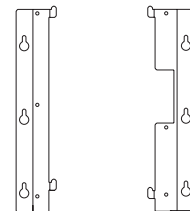

- **Floppy Disks (3) (PLX900 Series Driver and Utility Disks)**

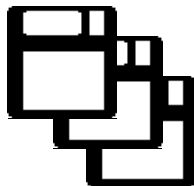

- **Floppy Disks (2) (PL-B910 Series USB Touch Panel Control Utility Disks)**



Special Features

The PL series units are equipped with the following unique features:

■ The Latest, High-Performance Architecture

Designed around the 333MHz AMD-K6[®]-2 Processor, the PL utilizes the type of high performance IBM compatible architecture that offers you superior performance. This allows you to easily use the popular Windows[®] 95, Windows[®] 98 Second Edition, Windows[®] NT operating systems, as well as others.

However, the software contained in the accompanying [Driver and Utility Disk] is designed specifically for use with only Windows[®] type OS. If this software is used with other OS types, its performance cannot be guaranteed.

▼ **Reference** ▲ For further information, refer to **6.1 Setting Up Your PL OS**

■ Highly Expandable

Choose from the PL-B901/PLB11 series unit - with 2 ISA slots, or the PL-B900/PL-B910 series unit - with 4 ISA slots. In addition, the PL-B901/PL-B911 unit provides a single PCI bus (slot 2), while the PL-B900/PL-B910 unit provides two PCI buses (slots 2 and 3). Also, these slots can accommodate both Digital's own optional boards as well as other commercially available expansion boards.

Digital also offers a wide variety of optional products, such as a -5/-12V DC power unit, DIM memory modules, etc.

■ Separately Designed Main Unit and Display

The PL's separated main unit and display offer you an expanded range of installation options for all your applications.

■ Special Design Digital Video Interface

The PL's unique state-of-the-art digital video interface dramatically reduces LCD display flickering.

■ Single Cable for Video and Touch Panel Signals

This all-in-one cable allows you to easily connect the PL's display and main units together.

■ Dual Display Feature (PL-B910 Series)

When the Display Expansion Board is installed in a single PL, two display units can be connected.

■ Dual Touch Panel Feature (PL-B910 Series)

In order to prevent the accidental misoperation of two simultaneously connected display units, a special interlock feature is used. This interlock feature, which is contained in the Interlock program, prevents accidental misoperation without requiring additional programming.

■ USB Interface (PL-B910 Series)

This standard type USB interface allows you to easily connect any standard type of USB compatible device.

UL/c-UL(CSA) Application Notes

The PL-B900 series and the PL-B910 series units are (c)UL 1950 recognized products. (UL File No. E171486). Please pay special attention to the following instructions when applying for UL/c-UL approval for machinery which includes any of these PL units. Equipment with a PL mounted in it requires UL/c-UL evaluation for the combination of the PL and equipment.

The PL conforms as a component to the following standards:

UL 1950, Third Edition, dated March 1,1998 (Standard for Safety of Information Technology Equipment, including Electrical Business Equipment)

CSA-C22.2 No. 950-M95 (Standard for Safety of Information Technology Equipment, including Electrical Business Equipment)

PL-B900-4*.*.*.* (UL Registration Model: 2780053-02) PL-B901-4*.*.*.* (UL Registration Model: 2780053-01)

PL-B910-4*.*.*.* (UL Registration Model: 2780056-02) PL-B911-4*.*.*.* (UL Registration Model: 2780056-01)

- The PL should be used as a built-in component of another product.
- Use the PL indoors only.
- When connecting the PL's power cord, be sure to use a cord that is appropriate for the current and voltage used, and that has conductive wires that are 0.75 mm² or larger.
- When an end-use product will include the PL, be sure to design the PL's power cut-off switch as a separate disconnect device and locate it where the operator can easily reach it.
- Danger of explosion if backup battery is incorrectly replaced. Replaced only with same or equivalent type recommended by the manufacturer. Dispose of used batteries according to the manufacturer's instructions.
- Be sure the unit the PL is built into is a (c)UL1950 approved structure.

CE Marking Notes

The PL-B900 and PL-B910 series units are CE marked, EMC compliant products.

<These units comply with the following standards>

■ **Safety**

EN60950

■ **EMI (EN50081-2)**

EN55011 Group1 (Class A)

■ **EMS (EN50082-2)**

EN61000-4-2, EN61000-4-3, EN61000-4-4, EN61000-4-6, EN61000-4-8, ENV50204

If following requirements are not met, the PL may fail to meet EN60950 standard requirements.

- The PL must be used as a built-in component of an end-use product.
- The PL is intended for indoor use only.
- When connecting the PL's power cord, be sure to use a cord that is appropriate for the current and voltage used and that has conductive wires that are 0.75 mm² or larger.
- When installing the PL in a metal panel or cabinet, be sure to place the PL's Power disconnect device (cut-off switch) where the unit's operator can easily reach it.
- There is a danger of explosion if the PL's backup battery is incorrectly replaced. This battery should be replaced only with same or equivalent type recommended by the manufacturer. Dispose of used batteries according to the manufacturer's instructions.
- Be sure the cabinet/enclosure the PL is built into uses an EN60950 approved sheet steel structure.

Memo

Chapter

1 PL Basics

1. Prior to Operating the PL
2. PL System Design
3. Optional Items

1.1 Prior to Operating the PL

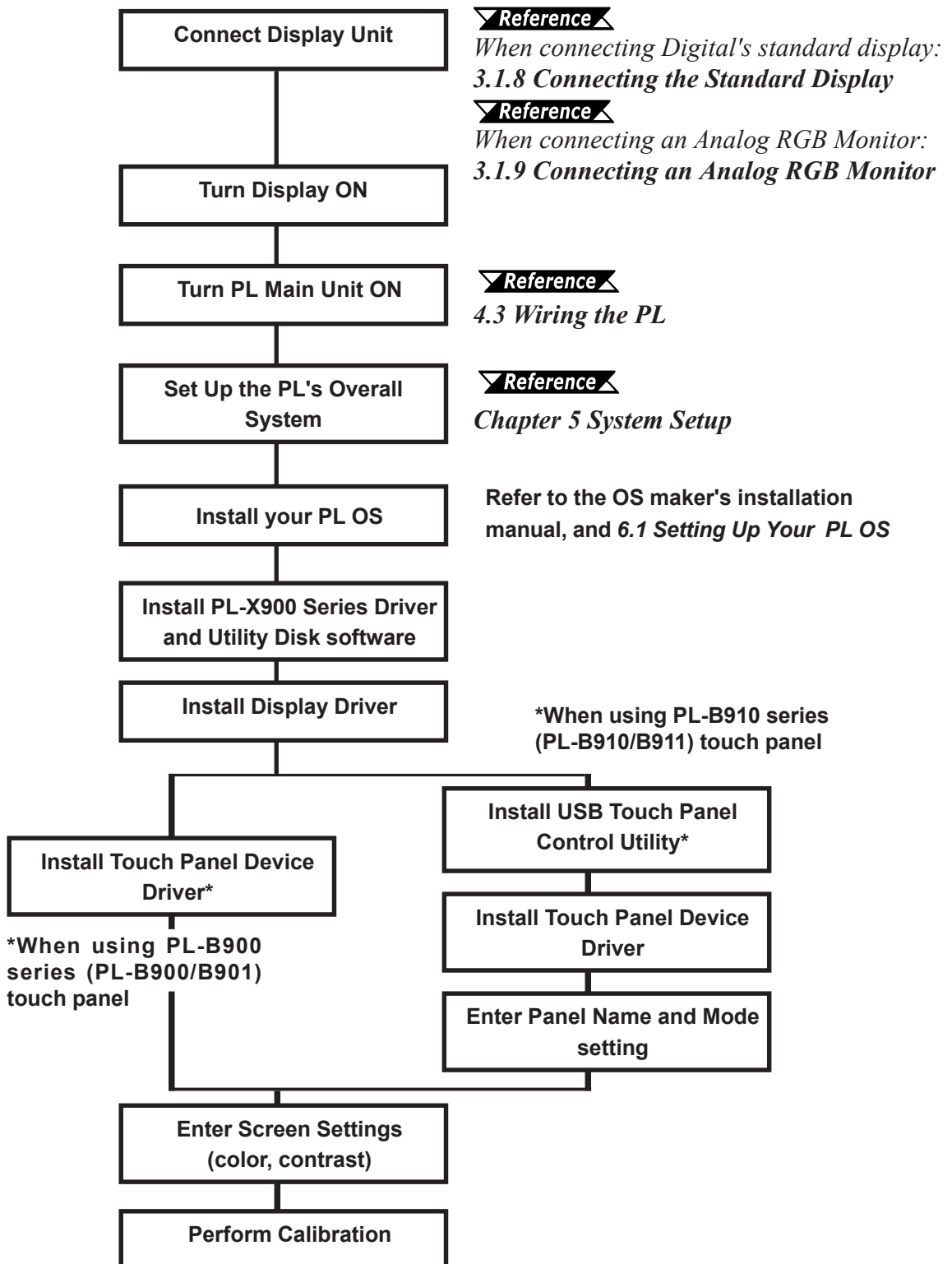



- **After completing the hardware setup, before any data or applications can be placed on the HDD drive, the OS (Windows® or MS DOS®, etc.) must be used to initialize the HDD and create partitions. For details concerning these procedures, refer to the OS maker's installation manual.**
- **For system setup and OS installation, a PS/2 type keyboard is necessary.**
- **Since the PL's hard disk drive (HDD) is a consumable item, i.e. it has a limited lifetime, be sure to back up its data regularly and prepare a spare HDD unit.**
- **After turning the PL OFF, be sure to wait at least 5 seconds before turning it ON again. If the unit is started too soon, it may not start up correctly.**
- **The software contained in the PL's accompanying [Driver and Utility Disk] is designed specifically for use with only the following OS types. If this software is used with other OS types, its performance cannot be guaranteed.**

PL Model	OS Type
PL-B900 Series units (PL-B900/PL-B901)	Windows® 95 Windows® NT
PL-B910 Series units (PL-B910/PL-B911)	Windows® 98 Second Edition

1.2 PL System Configuration

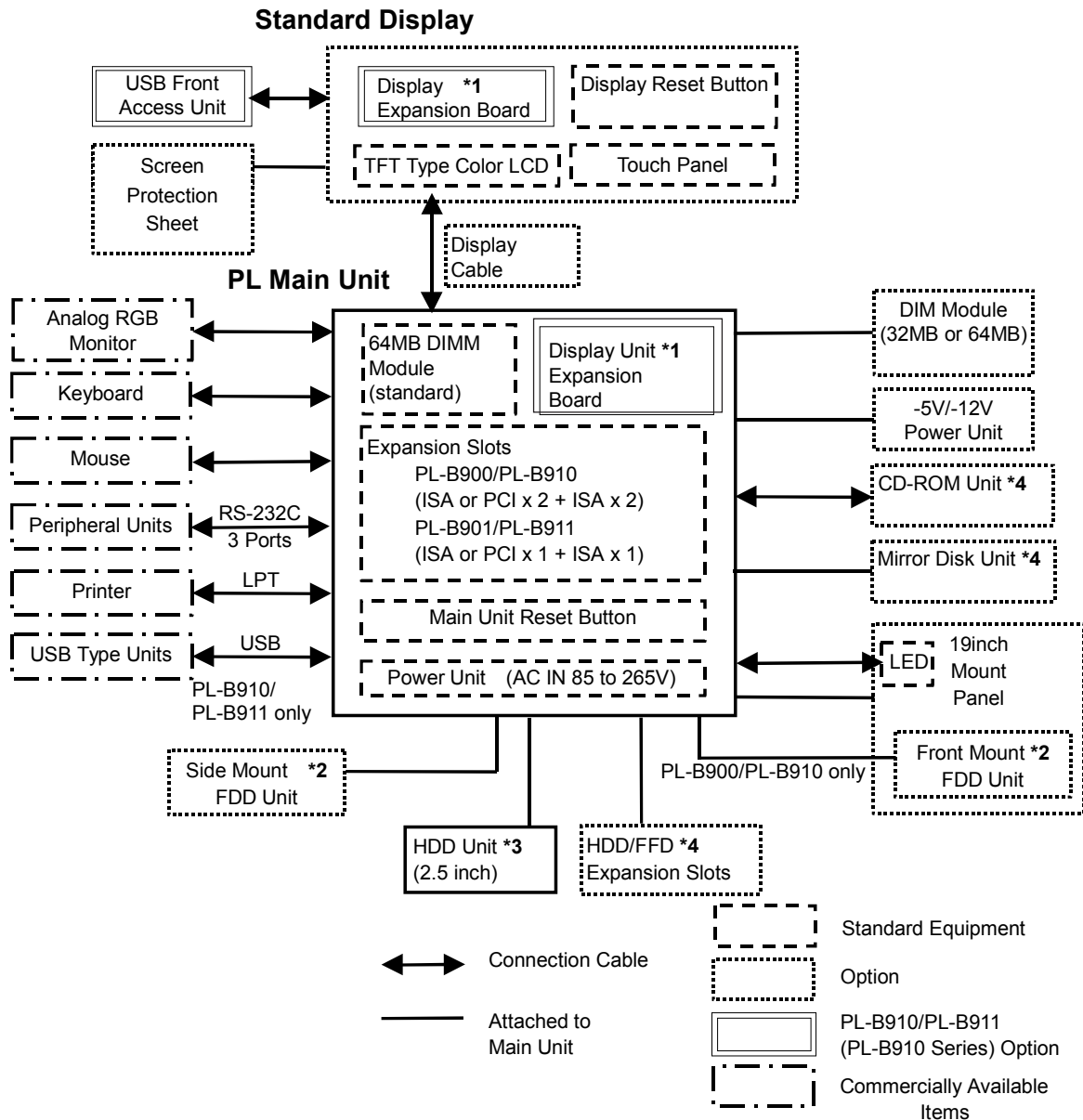

*1 The PL-B910/B911 Dual Display requires the Display Expansion board for either the PL or the DU.

*2 The PL-B900/B910 side and front mount FDD units can be used individually, not simultaneously.

*3 This unit becomes an option when the PL Main Unit contains no standard HDD unit.

*4 Certain limitations exist for the combinations of the HDD unit, the FFD unit, the Mirror

Disk unit and the CD-ROM drive. **Reference** 1.3 Optional Items



The above system configuration represents the internal design and peripheral equipment connectable to the PL. The user's actual combination of these items may differ.

1.2.1 Connecting the Dual Displays

The PL-B910/PL-B911(PL-B910 Series) units can use up to 2 DU series displays. Connecting two displays requires two of the optional display cables (PL-CB200-5M) and one Display Expansion Board (PL-PE200). Use the following explanations when connecting the DUs and the Display Expansion Board.

Reference Chapter 3.1.8 Attaching the Display Expansion Board (PL-PE200)

When using the PL-B900/PL-B901 units, only one display can be attached to one PL unit.

There are two types of installation methods; the Star connection or the Daisy Chain connection.



The performance of any connection method used that is different from those shown below is not guaranteed.

■ Star Connection

With the Star Method, the Display Expansion Board is installed in the PL and both display cables are connected to the PL.

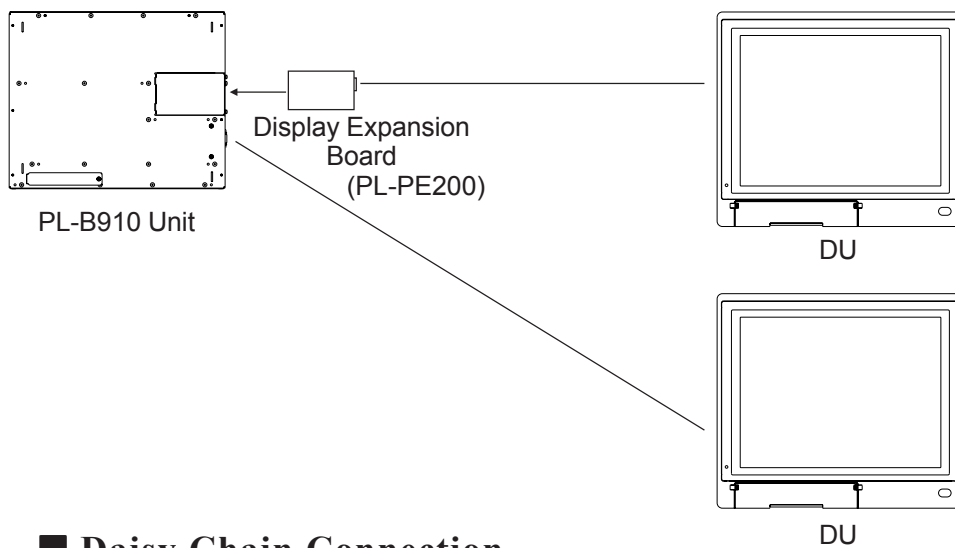

■ Daisy Chain Connection

With this method, the Display Expansion Unit is installed in the first DU unit, and the 2nd DU unit is connected to the first DU unit.

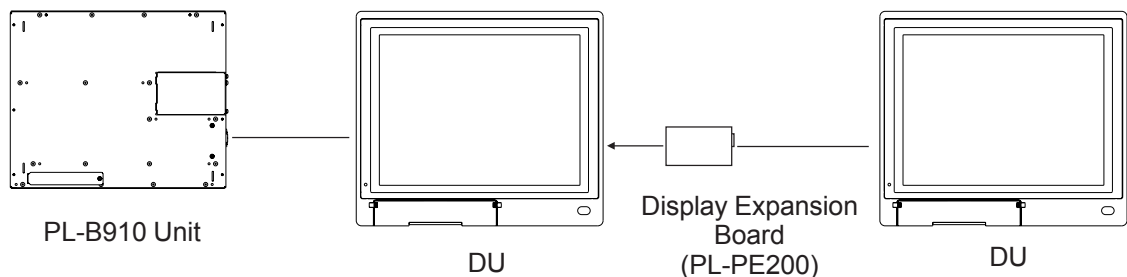

Note: If the first DU unit in the chain is not turned ON, the second DU cannot operate.

Chapter 1 - PL Basics

When attaching the Dual Displays, be sure of the following points.

- The PL unit is a PL-B910 series unit (PL-B910 or PL-B911).
- The DU units used are the same model.
- The operating system is Windows 98 Second Edition.
- Set the DU's dip switches according to the "PL-B910 Series" setting.

Reference *PL-DU6900/PL-DU7900 User Manual 2.3.1 Using Dip Switch for Settings*

- Be sure each DU unit's station number is unique.

Reference *PL-DU6900/PL-DU7900 User Manual 2.3.1 Using Dip Switch for Settings*

- Be sure the display cable is the PL-CB200-5M.



- **Do not connect more than 2 DU units to a single PL, since doing so may cause the PL to malfunction.**
- **When using Dual Displays, be sure to install the PL's interlock program to prevent interlock feature conflicts and PL unit malfunctions.**
- **To prevent accidental touch operation conflicts or misoperation when the Dual Display feature is used, be sure to use the Touch Interlock program included with the PL's utility disks.**

1.3 Optional Items

Name	Model number	Description
Standard Display	PL-DU6900-T42	12.1 inch TFT display panel made by the Digital Electronics Corporation. Connects to PL Main Unit.
	PL-DU7900-T42	15 inch TFT display panel made by the Digital Electronics Corporation. Connects to PL Main Unit.
Display Unit Cable	PL-CB200-5M	Connects Standard Display and Main Unit. (5m)
	PL-CB200-10M	Connects Standard Display and Main Unit. (10m) (Used only with PL-B900/PL-B910 units)
DIM Module	PL-EM220	SDRAM (DIMM) Provides 32MB of memory
	PL-EM230	SDRAM (DIMM) Provides 64MB of memory
FDD Unit	PL-FD200	IBM PC Compatible 3.5" FDD unit (Attaches to side slot)
	PL-FD210	IBM PC Compatible 3.5" FDD unit (Attaches to front slot) Only for PL-B900 & PL-B910
FFD Unit	PL-FF200	20MB Flash File Disk with IDE interface. Used the same way as an HDD.
Mirror Disk Unit	PL-MD200-HU01	IDE type mirror disk unit without OS. Continuously backs up data to 2nd drive, to protect against an HDD malfunction. Contains two 2.5 inch, 2.1GB hard disk drives.
-5V/-12V Power Unit	PL-PW100	Provides -5V and -12V power to expansion slots. Can provide a total of 200mA of current. (sum of both slots)
LAN Board	DAX-IET02	NE2000 compatible Ethernet board. Provides connectors for 10BASE-5, 10BASE-2 & 10BASE-T.
Display Expansion Board	PL-PE200	Connects an additional DU unit to the PL. (only PL-B910 and PL-B911)
CD-ROM Unit	PL-DK200	IDE (ATAPI) compliant CD-ROM drive unit – for development and maintenance use (special connection cable is included)
19 Inch Mounting Panel	PL-RM200	Used to install the PL into a 19 inch rack.
Full-sized Cover	PL-FC200	Attached when an ISA or PCI bus full-sized board is used in the expansion slot. (for PL-B901, PL-B911)
	PL-FC210	Attached when an ISA or PCI bus full-sized board is used in the expansion slot. (for PL-B900, PL-B910)
Windows® 95 Touch Panel Device Driver	PL-ME000	Required for all PL units sold with no OS. Can be used only with a PL using Windows® 95. To use Windows® NT 4.0, use the Gunze company's TT-WIN/NT driver.



Note: The side and front mount FDD units can be used individually, not simultaneously.

Chapter 1 - PL Basics



The PL is equipped with three IDE interfaces, two (2) of which can be used by the HDD or FFD units, and one (1) which can be used by either the CD-ROM drive or the Mirror Disk unit. Physically, even though up to three (3) IDE drive units can be connected at the same time, IDE interface specifications require that a controller's simultaneous operation be limited to a single master and slave unit, for a total of two devices. The following chart shows the combinations available when using two IDE units.

HDD Unit	MS	M	M	M	S				S		
FFD Unit		S			M	MS	M	M		S	
Mirror Disk Unit			S				S		M	M	M
CD-ROM Drive Unit				S				S			S

MS: Any combination of 2 units - Master or Slave, is possible.

M: Used only for Master.

S: Used only for Slave.

■ Maintenance Options

Name	Model Number	Description
HDD Unit	PL-HD2*0	Built-in 2.5" HDD unit (contains no pre-installed OS) *:Hard Disk Revision
Mirror Disk Unit Replacement HDD	PL-MD200-MD01	Mirror Disk Unit's replacement HDD (1)



- *Since the PL unit's hard disk drive (HDD) is a consumable item, i.e. it has a limited lifetime, be sure to back up its data regularly and prepare a spare HDD unit.*
- *The Hard Disk lifetime given here may be reduced due to unforeseen environmental factors, however, generally speaking, at an operating temperature of 20°C the disk should last for 20,000 hours (of operation) or approximately 5 years, whichever comes first.*

■ Commercially Available Items

- When setting up the touch panel of a PL-B900 Series (PL-B900/PL-B901) unit with no pre-installed OS, be sure to use the Gunze Company's [TT-WIN/NT] Touch Panel Device Driver if you install the Windows® NT system. If you decide to install the Windows® 95 system, please use Digital's Windows® 95 Touch Panel Device Driver PL-ME000.
- The PL-B900 and PL-B910 Series units can all use commercially available expansion boards (PCI/ISA compatible) as well as a standard keyboard, mouse, printer, etc. The PL-B910 Series units, can also use USB compatible devices. However, among the commercially available USB devices, not all will be compatible with the PL unit. For a list of the USB units that can be used with your PL, please contact your local PL distributor.

Chapter 1 - PL Basics



- **Since the PL expansion slots do not supply DC-5V and DC-12V current. To use expansion boards requiring DC-5V or DC-12 V, the optional PL-PW100 power supply should be installed.**
- **Be sure to use only DIMM modules made by Digital Electronics Corporation. Certain commercial DIMM modules may fail to meet the PL unit's specifications and cause the PL to malfunction.**
- **When using USB type devices, be sure they are USB compatible, and be sure to read that device's installation guide prior to connecting it to the PL.**

Chapter

2 Specifications

1. General Specifications
2. Functional Specifications
3. Interface Connector Specifications
4. PL Part Names and Features
5. Panel Dimensions

2.1 General Specifications

2.1.1 Electrical

	PL-B900/PL-B910	PLB901/PL-B911
Input Voltage	AC100V to AC240V	
Rated Voltage	AC85V to AC265V	
Frequency	50/60Hz	
Allowable Voltage Drop	1 cycle or less (however, pause occurrences must be more than 1 second apart)	
Power Consumption	150VA or less	100VA or less
Voltage Endurance	AC1500V 20mA for 1 minute (between charging and FG terminals)	
Insulation Resistance	10MΩ or higher at DC500V (between charging and FG terminals)	

2.1.2 Structural

	PL-B900/PL-B910	PLB901/PL-B911
Ambient Operating Temperature	With Fan: 5°C to 50°C	
	Without Fan ^{*1} : 5°C to 40°C	
Storage Temperature	-10°C to 60°C	
Ambient Humidity	30%RH to 85%RH	
Air Purity Level	Free of conductive particles and dust	
Atmosphere	Free of corrosive gasses	
Vibration Resistance	19.6m/s ² at 10Hz to 25Hz in X, Y, Z directions for 30 minutes With Hard Disk attached: 4.8m/s ² With Floppy Disk attached: 9.8m/s ²	
Noise Endurance (via noise simulator)	Noise Voltage: 1500V Pulse Width: 50ns, 500ns, 1μs Arise Time: 1ns	
Noise Immunity	2kV	IEC 61000-4-4
Electrostatic Discharge Immunity	4kV	IEC 61000-4-2

*1 When PL's internal fan is removed.

Chapter 2 - Specifications



- **When using any of the PL's optional devices, be sure to check that device's specifications for any special conditions or cautions that may apply to its use.**
- **When using a full sized expansion board, be sure to check its dimensions and shape, since they will affect the PL's environment specifications, such for vibration, etc.**
- **Since the PL unit's hard disk drive (HDD) is a consumable item, i.e. it has a limited lifetime, be sure to back up its data regularly and prepare a spare HDD unit.**
- **The Hard Disk lifetime given here may be reduced due to unforeseen environmental factors, however, generally speaking, at an operating temperature of 20°C the disk should last for 20,000 hours (of operation) or approximately 5 years, whichever comes first.**
- **Using the Hard Disk in an environment that is excessively hot and/or humid will shorten the disk's usage lifetime. A maximum wet bulb temperature of 29°C or less is recommended. This is equivalent to the following data.**

Temperature	Humidity
at 35°C	no higher than 71%
at 40°C	no higher than 54%
at 50°C	no higher than 33%

2.1.3 Environmental

	PL-B900/PL-B910	PL-B901/PL-B911
Grounding	Exclusive grounding: Use your country's applicable standard. *1	
Installation Method	Inside a solid, flat panel	
Cooling Method	Via cooling pipes and power supply cooling fan	
Weight	7.5kg (16.5lb) or less (with HDD and FDD installed)	6.5kg (14.3lb) or less (with HDD and FDD installed)
External Dimensions	330mm(12.99in.) W x 271mm(10.67in.) H x 162mm(6.38in.) D (excluding projections)	330mm(12.99in.) W x 271mm(10.67in.) H x 116mm(4.57in.) D (excluding projections)
Dimensions Including Full-sized Cover	385mm(15.16in.) W x 271mm(10.67in.) H x 162mm(6.38in.) D (excluding projections)	385mm(15.16in.) W x 271mm(10.67in.) H x 116mm(4.57in.) D (excluding projections)
Dimensions Including Mirror Disk Unit	330mm(12.99in.) W x 271mm(10.67in.) H x 166mm(6.54in.) D (excluding projections)	330mm(12.99in.) W x 271mm(10.67in.) H x 166mm(6.54in.) D (excluding projections)

*1 **Reference** Refer to 4.3.3 Grounding Cautions.

2.2 Functional Specifications

2.2.1 General

CPU		333 MHz AMD-K6® -2 Processor (AMD Corporation)		
DRAM (SDRAM DIMM)		64MB Standard (2 DIMM sockets: max. of 128MB)		
BIOS		AWARD PC/AT Compatible		
Secondary Cache Memory		512Kbytes (built-in)		
Graphics		VGA (640 x 480 dots) to XGA (1024 x 768 dots) VESA 16 colors/256 colors/32K colors/64K colors		
Video Memory		2MB (SDRAM)		
Inter-faces	Video	Analog RGB I/F Digital Video I/F (only for PL-DU*900 via PL-CB200-10M or PL-CB200-5M)		
	Touch Panel	COM4 : uses Mouse Emulator USB: uses USB Touch Panel Driver (PL-B910/PL-B911)		
	Serial	RS-232C (w/FIFO)	COM1	D-Sub 9 pin (male)
			COM2	D-Sub 9 pin (male)
			COM3	D-Sub 9 pin (male)
	Printer	Centronics Standard (ECP/EPP equivalent) D-sub 25 pin, female		
	Keyboard	PS/2 Interface (mini DIN 6 pin, female)		
	Mouse	PS/2 Interface (mini DIN 6 pin, female)		
	RAS	RAS Interface (D-sub 25 pin, male)		
	Disk I/F	FDD Unit	Side Access/ 2 modes/ 3.5 inch FD	
Front Access/ 2 modes/ 3.5 inch FD (Available for only PL-B900 & PL-B910)				
E-IDE		2.5 inch HDD I/F		
USB	USB Interface compatible with USB 1.0 1 channel (PL-B910 & PL-B911 only)			

Chapter 2 - Specifications

2.2.2 Expansion Slots

	PL-B900/ PL-B910 (4-slot type)	PL-B901/ PL-B911 (2-slot type)	Board Size		Slot Pitch	Actual Thickness of Expansion Board
			Without Full-sized cover	With Full-sized cover		
1 st slot	ISA	ISA	163 x 122 mm	163 x 122 mm	20 mm	Less than 13 mm
2 nd slot	PCI	PCI	250 x 122 mm	250 x 122 mm	25 mm	Less than 18 mm
	ISA	ISA		338 x 122 mm		
3 rd slot	PCI/ISA	None	250 x 122 mm	338 x 122 mm	25 mm	Less than 18 mm
4 th slot	ISA	None	250 x 122 mm	338 x 122 mm	20 mm	Less than 13 mm
Power Supply	5V: 4A, 12V: 1A (total for 4 slots)	5V: 2A, 12V: 0.5A (total for 2 slots)				



Note: For the 2nd and 3rd slots on the PL-B900/PL-B910, and the 2nd slot on the PL-B901/PL-B911, either a PCI or an ISA type expansion board can be used.

Reference For PL dimensions when using the full-sized cover, refer to **1-3 Optional Items**.

2.2.3 Clock (RTC) Accuracy

Clock(RTC) accuracy	±180 seconds per month
---------------------	------------------------

The PL unit's built-in clock (RTC) has a slight error. At the PL's specified ambient temperature and with the power turned OFF the error is +180 seconds per month. However, ambient temperature fluctuations and the age of the unit may increase this error to +300 seconds per month. If the PL unit's RTC clock accuracy is vital to system performance, regular adjustment of this clock is required.

2.3 Interface Specifications

2.3.1 Keyboard Interface

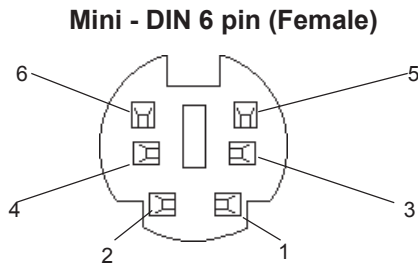

Pin No.	Signal Name
1	KEY DATA
2	NC
3	GND
4	+5V
5	KEY CLK
6	NC
SHIELD	GND

2.3.2 Mouse Interface

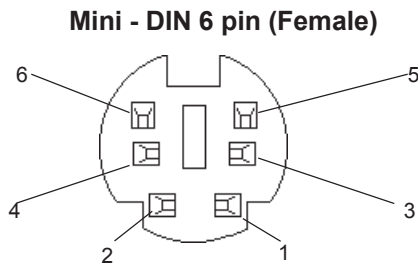

Pin No.	Signal Name
1	Mouse DATA
2	NC
3	GND
4	+5V
5	Mouse CLK
6	NC
SHIELD	GND

2.3.3 CRT Interface

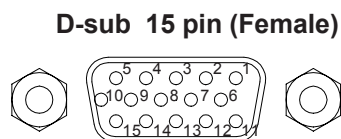

Screw Size: (4-40): Inch Type

Pin No.	Signal Name	Meaning
1	Analog R	R signal input
2	Analog G	G signal input
3	Analog B	B signal input
4	Reserved	NC
5	GND	Digital signal ground
6	Return R	R signal GND
7	Return G	R signal GND
8	Return B	R signal GND
9	Reserved	NC
10	GND	Digital signal ground
11	Reserved	NC
12	Reserved	NC
13	H-SYNC	Horizontal signal Input
14	Y-SYNC	Vertical signal input
15	Reserved	NC

Chapter 2 - Specifications

2.3.4 RS-232C Interface (COM1/COM2/COM3)

D-sub 9 pin (Male)

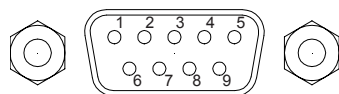

Pin No.	Signal Name	Pin No.	Signal Name
1	CD	6	DSR
2	RXD	7	RTS
3	TXD	8	CTS
4	DTR	9	RI
5	GND		

Screw Size: (4-40): Inch Type



The GND terminal is the signal ground. Be sure to connect it with the cable's opposite side SG terminal.

2.3.5 Printer Interface (LPT1)

D-sub 25 Pin (Female)

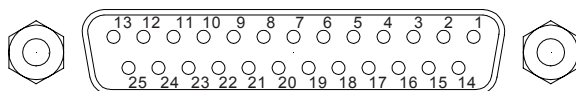

Screw Size: (4-40): Inch Type

Pin No.	SPP/ECP Mode Signal Name	EPP Mode Signal Name	Direction	Electrical Specif.	Pin No.	SPP/ECP Mode Signal Name	EPP Mode Signal Name	Direction	Electrical Specif.
1	STRB	WRITE	In/Output	O.D/T.S	14	AUTOFD	DSTRB	In/Output	O.D/T.S
2	DATA0	DATA0	In/Output	T.S	15	ERROR	ERROR	Input	TTL
3	DATA1	DATA1	In/Output	T.S	16	INIT	INIT	In/Output	O.D/T.S
4	DATA2	DATA2	In/Output	T.S	17	SLCTIN	ADSTRB	In/Output	O.D/T.S
5	DATA3	DATA3	In/Output	T.S	18	GND	GND		
6	DATA4	DATA4	In/Output	T.S	19	GND	GND		
7	DATA5	DATA5	In/Output	T.S	20	GND	GND		
8	DATA6	DATA6	In/Output	T.S	21	GND	GND		
9	DATA7	DATA7	In/Output	T.S	22	GND	GND		
10	ACKNLG	ACKNLG	Input	TTL	23	GND	GND		
11	BUSY	WAIT	Input	TTL	24	GND	GND		
12	PE	PE	Input	TTL	25	GND	GND		
13	SLCT	SLCT	Input	TTL					



Pins 1, 4, 16 and 17 will become O.D when the SPP mode specification is used. If the mode changes to ECP or EPP, these pins will become T.S

Chapter 2 - Specifications

2.3.6 RAS Interface

D-Sub 25 pin (Male)

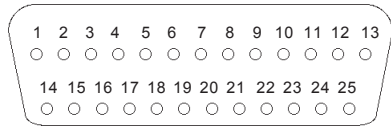

Screw Size: (4-40): Inch Type

Pin No.	Signal Name	Pin No.	Signal Name
1	GND	14	GND
2	+5V	15	+5V
3	+12V	16	NC
4	NC	17	NC
5	RESET INPUT (+)	18	NC
6	DIN 0 (+)	19	NC
7	DOUT (-)	20	NC
8	DOUT (+)	21	LAMP OUT (-)
9	ALARM OUT (-)	22	LAMP OUT (+)
10	ALARM OUT (+)	23	NC
11	RESET INPUT (-)	24	DIN1 (-)
12	DIN 0 (-)	25	NC
13	DIN 1 (+)		



Note: For detailed RAS Feature information,

Reference Appendix 2 RAS Feature.

External Input Signal (Used for both DIN and Remote Set Input)

- External Power : DC12V to DC24V
- Input Hold : Hold Diode
- Isolation (Interface Circuit) : Used (Photo isolation)

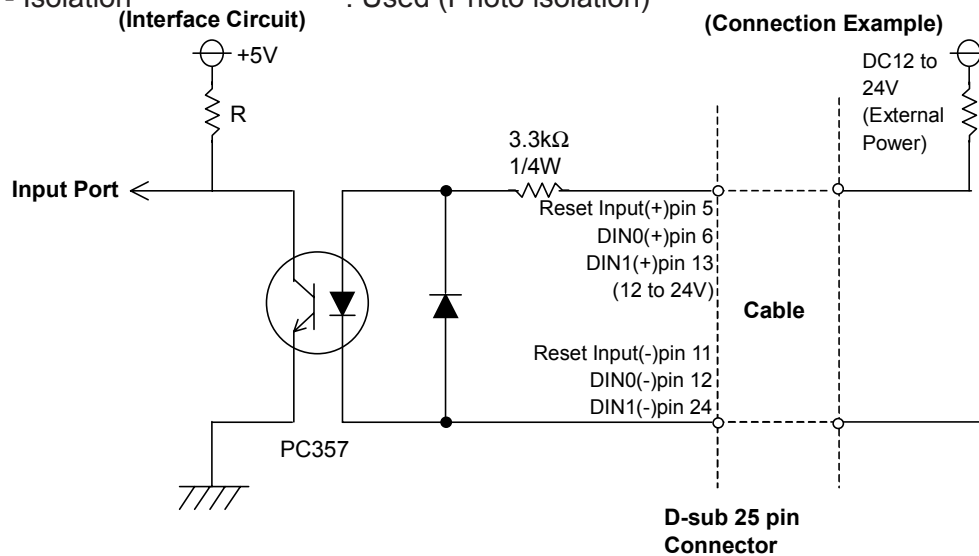

Chapter 2 - Specifications

■ External Output Signal (DOUT, Alarm Output, Lamp Output Port)

- Output Specification : DC24V 100mA (MAX)
- Isolation : Used (Photo isolation)

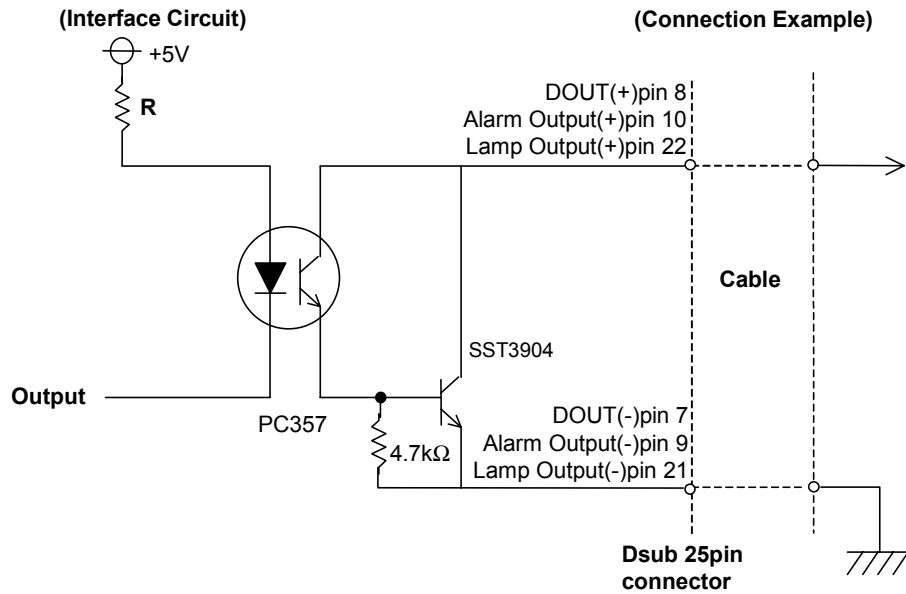

2.3.7 USB Interface (USB)

Receptacle

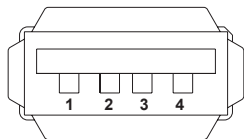

Pin No.	Name
1	Vcc
2	- Data
3	+ Data
4	GND

2.4 PL Part Names and Features

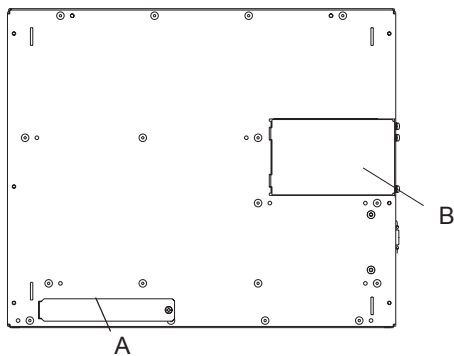

Front Face

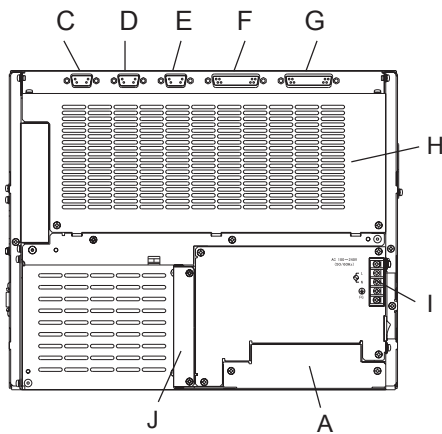

PL-B900/PL-B910 Rear Face

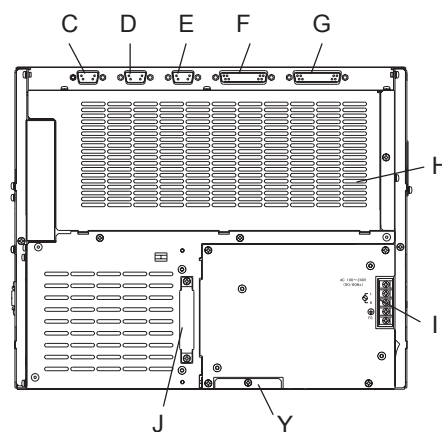

PL-B901/PL-B911 Rear Face

A: Front Face FDD Unit Attachment Slot

Digital's optional PL-FD210 is attached here.

B: Display Expansion Board Cover

Digital's optional expansion board (PL-PE200) is attached here to allow the connection of an additional display unit. (PL-B910/PL-B911 only)

C: RS-232C Connector (COM1)

D: RS-232C Connector (COM2)

E: RS-232C Connector (COM3)

These RS-232C interfaces (D-sub 9 pin male connectors), allow communication with other computers and connection to peripheral devices.

F: Printer Connector (LPT1)

Centronics standard interface (D-sub 25 pin female connector), which connects a parallel device, such as a printer. (supports ECP/EPP)

G: RAS Connector

Interface for DIN, DOUT, Watchdog, and Remote Reset. (D-sub 25 pin male connector)

H: Rear Maintenance Cover

When optional DIM modules or Expansion Boards are installed, this cover must be removed.

I: Power Terminal Block

The PL's AC100V/240V power cord terminals are connected here.

J: IDE I/F Cover

To connect the optional CD-ROM drive unit (PL-DK200) and Mirror Disk Unit (PL-MD200-HU01), remove this cover and use this connector.

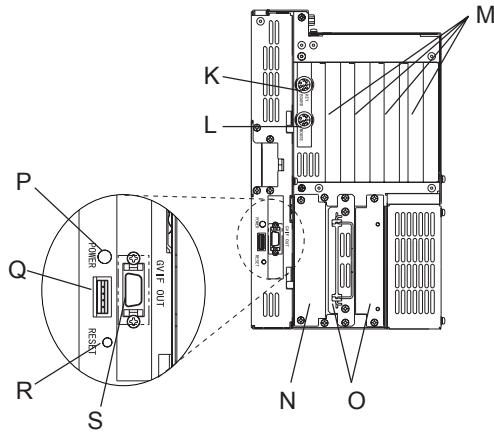

PL-B900 Right Face

K: Keyboard Connector

A PS/2 compatible keyboard can be connected here.

L: Mouse Connector

A PS/2 compatible mouse can be connected here.

M: Expansion Slots

Slots for PCI/ISA Bus compatible expansion boards.

N: Side Mount FDD Slot

Houses the FDD (PL-FD200) unit.

O: HDD/FDD Expansion Slot

Houses either the FFD or the HDD unit.

P: Power LED

This LED indicates both the RAS monitor feature's status and the PL's power status. An RAS alarm will cause this lamp to blink.

Reference *Appendix 2 RAS Feature*

Q: Power LED Output Connector

Used when installing the PL in the optional 19" mount to provide power LED output.

R: Hardware Reset Switch

Pushing this switch resets the PL.

S: Standard Display Connector (GVIF OUT)

Used to connect Digital's Standard Display Cable. (PL-CB200-*M)

T: Standard USB Connector (USB)

This interface is USB 1.0 compliant. Compatible USB devices can be connected here. (PL-B910/PL-B911)

U: Dip Switches (SEL.)

Use the factory settings. (PL-B910/PL-B911 only)

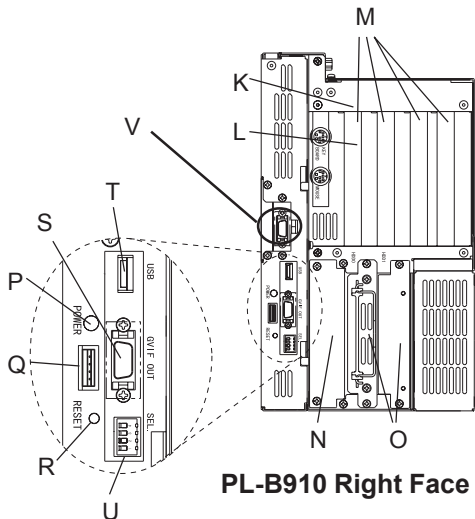

PL-B910 Right Face

OFF ON OFF ON

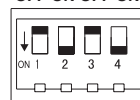

Factory Settings

Be sure to set the DU unit's dip switches to the same setting as the PL.

Reference *PL-X900 Series Standard Display PL-DU6900/PL-DU7900 Users Manual.*

V: Expansion Display Connector

When using 2 DU units, Digital's display cable must be used (PL-CB200-5M). This cable connects to the PL's Display Expansion Board (PL-PE200). The picture used here shows the Display Expansion Board installed. (PL-BP10/PL-B911 only)

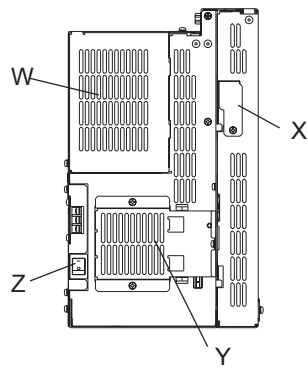

PL-B900/PL-B910

Left Face

W: Half Cover

When installing an optional DIM module or expansion board, this cover is removed.

X: Analog RGB Connector Cover

Provides an analog RGB interface. Remove this cover when attaching an RGB (CRT) monitor to the PL.

Y: Filter Cover

Remove this cover when cleaning or removing the PL's cooling fan.

Z: Power Switch

Turns the PL main unit ON or OFF.

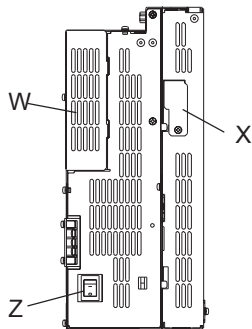

PL-B901/PL-B911

Left Face

2.5 PL External Dimensions

2.5.1 PL-B900/B910 Series External Dimensions

(Unit: mm (in.) - excluding projections)

■ PL-B900/PL-B910 (4-slot type)

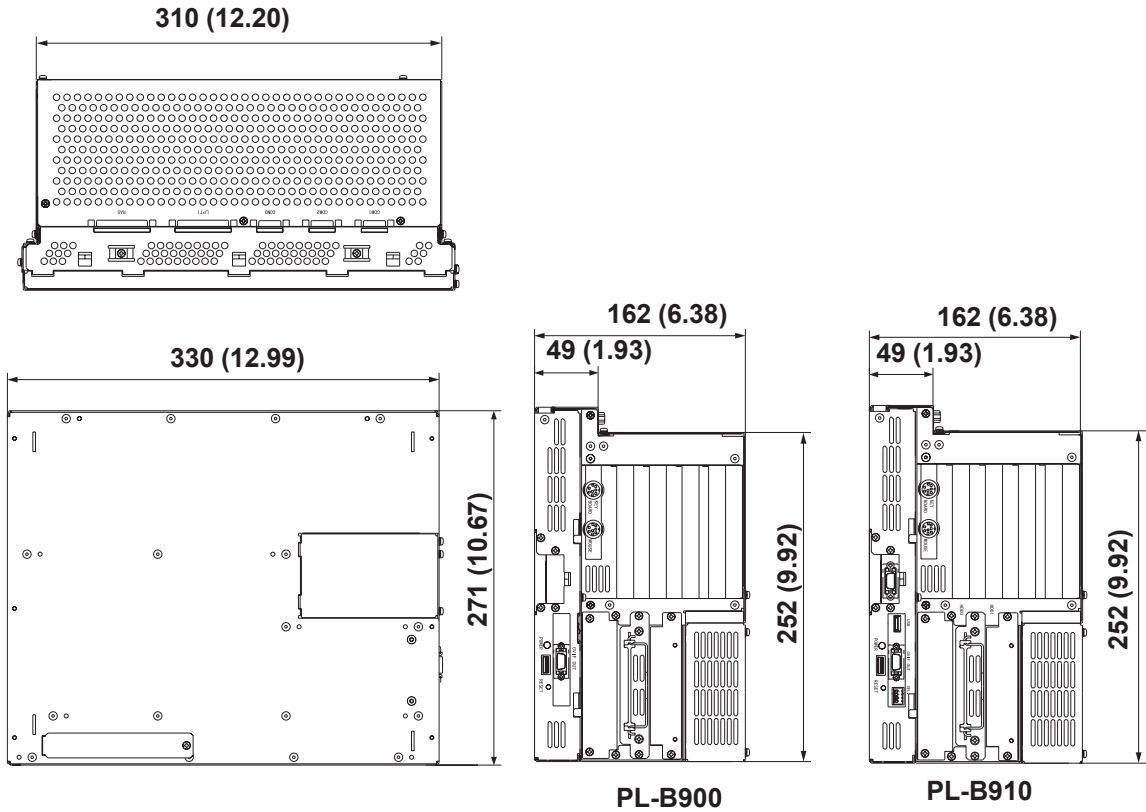

◆ Front Face Mount FDD Unit Installation Slot

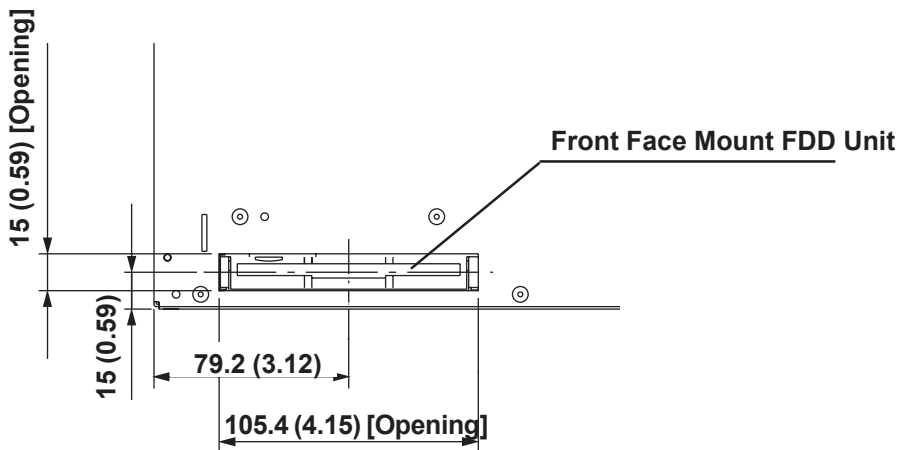

Chapter 2 - Specifications

■ PL-B901/PL-B911 (2-slot type)

(Unit: mm (in.) - excluding projections)

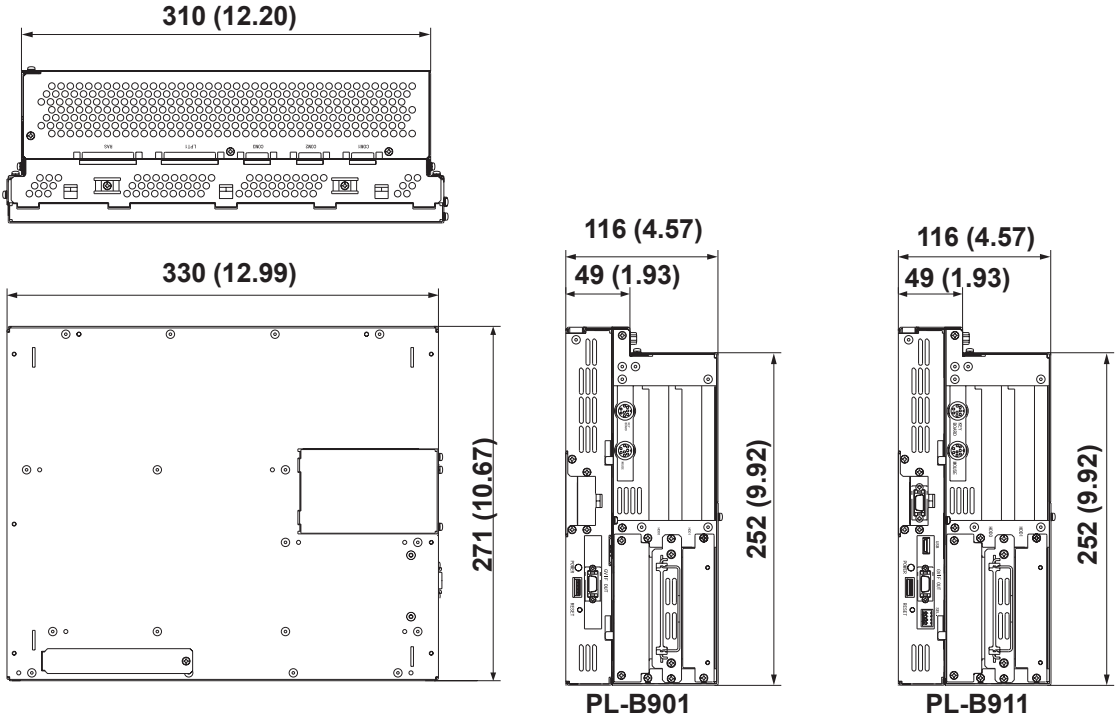

Chapter 2 - Specifications

2.5.2 Installation Fasteners

■ PL-B900/PL-B910 (4-slot type) (Unit: mm - excluding projections)

The attachment screw measurements are the same for both units.

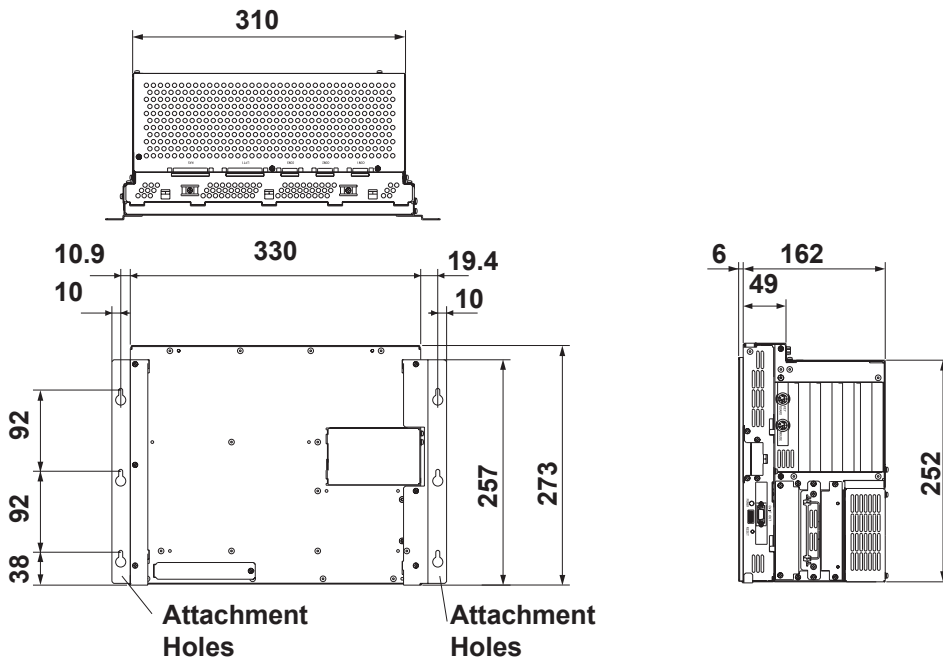

■ PL-B901/PL-B911 (2-slot type)

The attachment screw measurements are the same for both units.

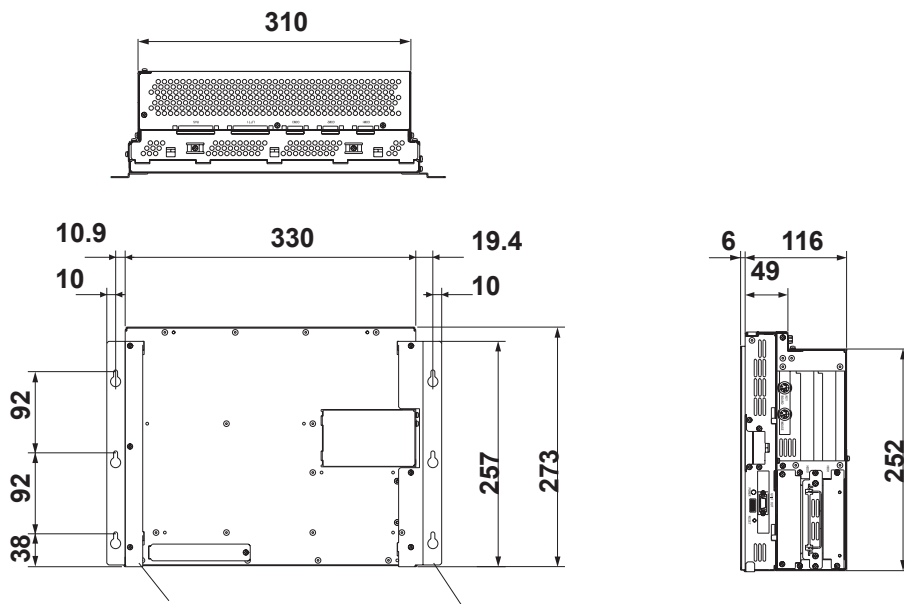

■ Attachment Bracket Attachment Holes (Detail)

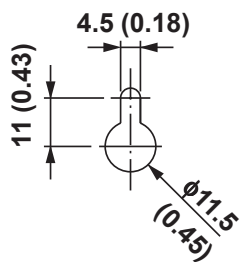

Chapter 2 - Specifications

■ Drilling Attachment Bracket Attachment Holes

Use the following dimension drawing to drill the attachment bracket attachment holes in the installation panel. Use M4 size screws for the screw holes.

(Unit: mm - excluding projections)

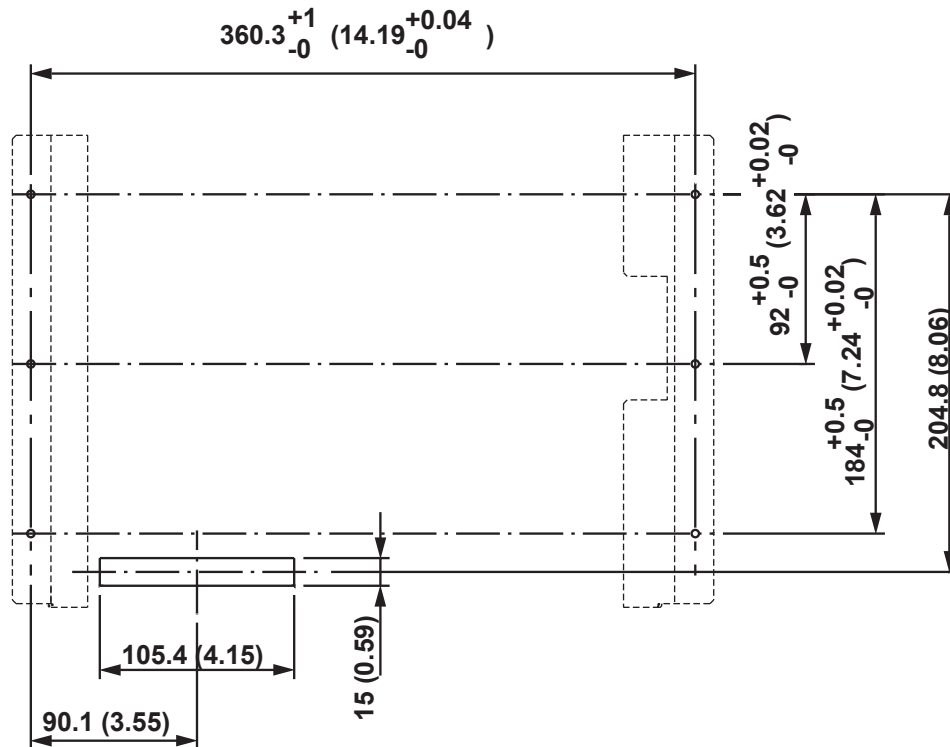

Front View Drawing



- Depending on the panel's material and design, the panel's installation surface may need to be strengthened. If high levels of vibration are expected and the PL's installation surface (i.e. an operation panel's door, etc.) can move (i.e. open or close) due consideration should be given to the PL's weight.

Reference 2.1.3 Environmental

- Be sure all installation tolerances are maintained to prevent the unit from falling out of its installation panel.

Chapter 2 - Specifications

2.5.3 Full-Sized Cover/Mirror Disk Unit Attachment Dimensions

■ PL-B900/PL-B910 (4-slot type) (Unit: mm - excluding projections)

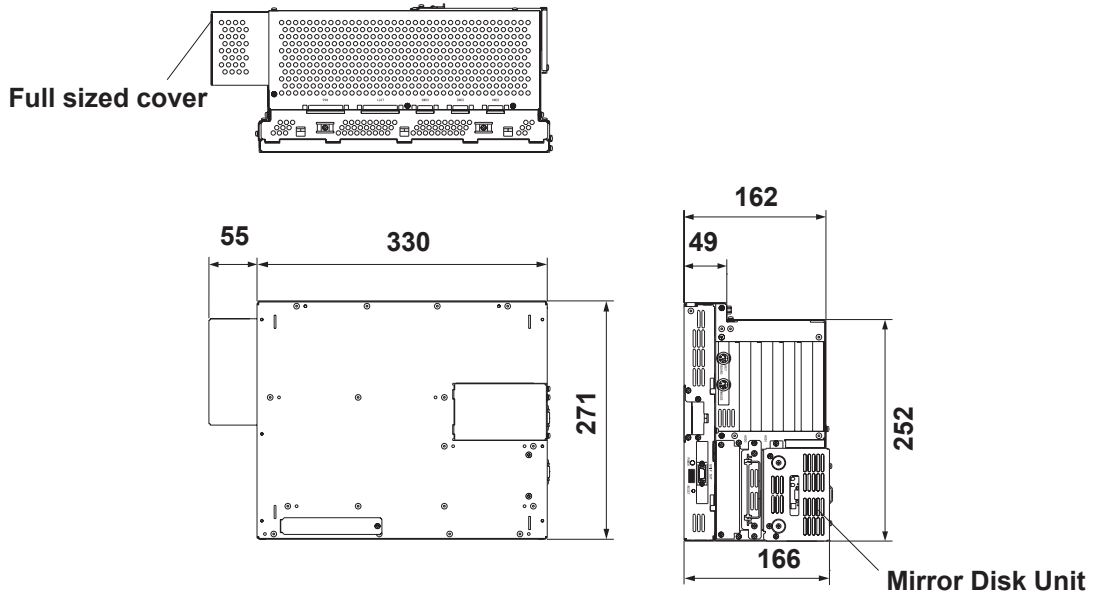

■ PL-B901/PL-B911 (2-slot type)

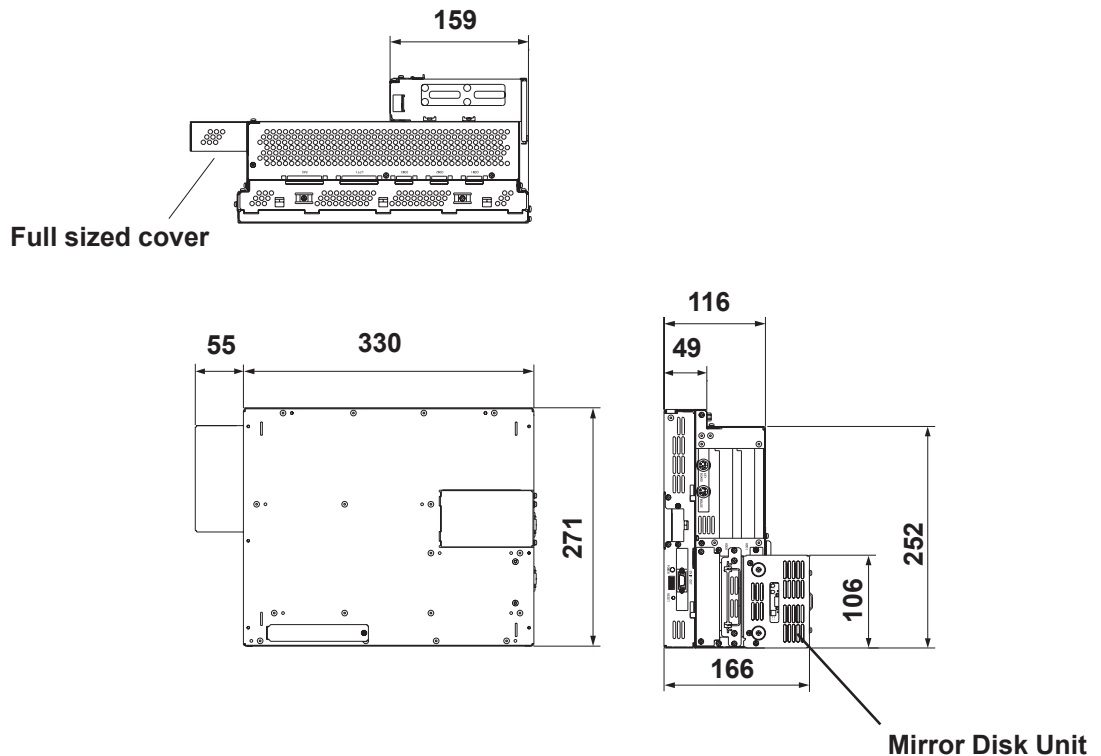

There are two types of full-sized covers - one for 4 slot units and one for 2 slot units.

2-Slot Type PL-FC200

4-Slot Type PL-FC210

Reference 1.3 Optional Items

Chapter 2 - Specifications



- ***Prior to installing a full-sized board and the PL's full-sized cover (PL-FC200/PL-FC210), be sure that the PL is mounted in its attachment panel/cabinet. Due to dimension differences, the PL-FC200 or a full sized expansion board can not be attached prior to installing the PL into a panel.***
- ***When using a full sized expansion board, be sure to check its dimensions and shape, since they will affect the board's environment specifications, such as for vibration, etc.***

Memo

Chapter

3

Installing Optional Units and Expansion Boards

A wide variety of optional units and expansion boards made by Digital can be installed in the PL, as well as a number of commercially available PCI-bus or ISA-bus compatible boards. This chapter describes how to install these products in the PL.

3.1 Installation

The following explanation pages describe the installation procedures for the PL's DIM module (PL-EM220/PL-EM230), FDD unit (PL-FD200/PL-FD210), HDD unit (PL-HD2*0), expansion boards, CD-ROM drive unit (PL-DK200), Display Expansion Board (PL-PE200), Special Display (PL-DU6900/PL-DU7900) and the PL's cooling fan.

For information about the installation of other option units, please refer to those unit's individual [Operation Instructions].



WARNING

To avoid electric hazards, be sure to turn the PL's power OFF before installing any optional units or expansion boards.



- **Use a screwdriver to loosen or tighten the screws. Be careful not to tighten screws too tightly, since it may damage the equipment.**
- **Be careful when removing or inserting any screws that they do not fall inside the PL.**

3.1.1 Removing the Rear Maintenance Cover



Be sure to handle the rear maintenance cover carefully, since it is made of aluminum and is easily bent.

■ PL-B900/PL-B910 Units (4 -slot type)

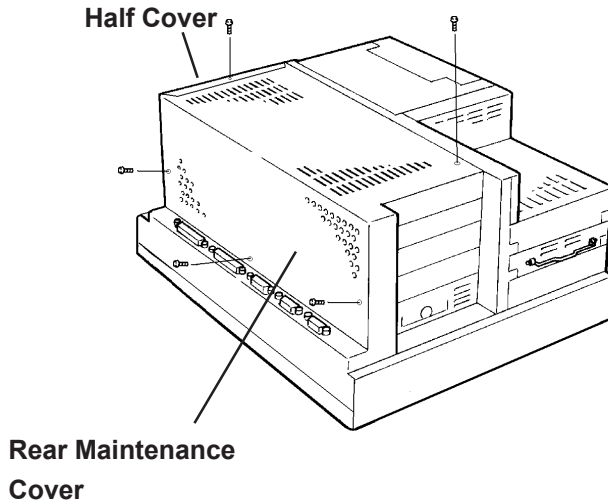

1) Unscrew the five (5) attachment screws used to hold the rear maintenance cover and half cover.

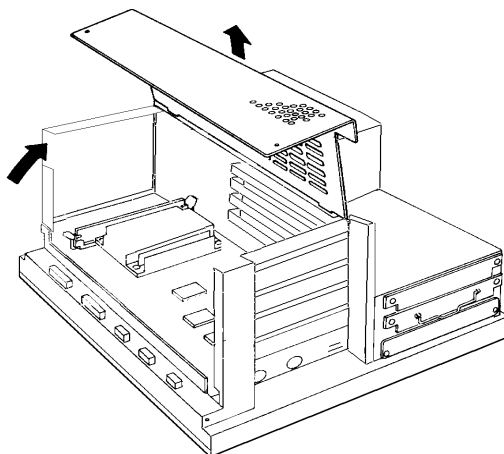

2) Remove the rear maintenance cover.

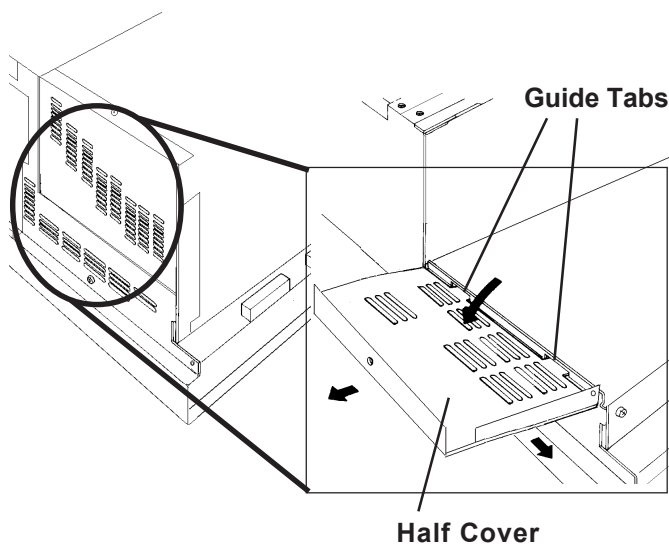

3) Pivot the half cover open and lift up slightly to free the guide tabs. Next, remove the half cover.

■ PL-B901/PL-B911 Unit (2-slot type)

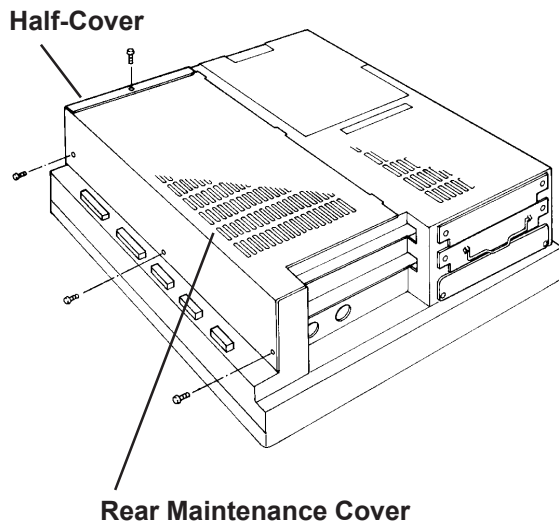

1) Unscrew the four (4) attachment screws used to hold the rear maintenance cover and half cover.

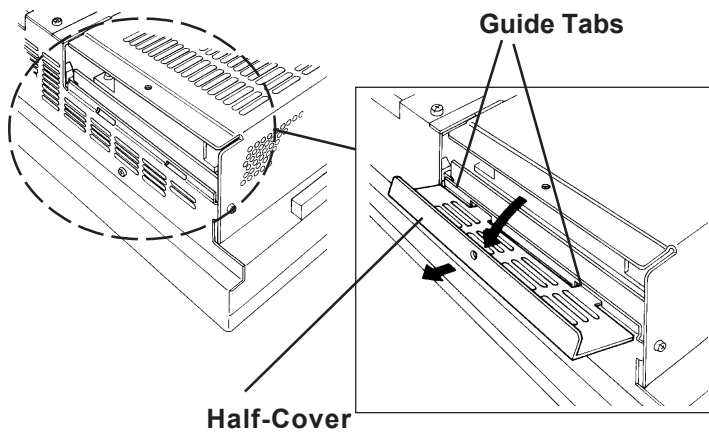

2) Pivot the half cover open and slide the cover slightly to the side to free the guide tabs. Next, remove the half cover.

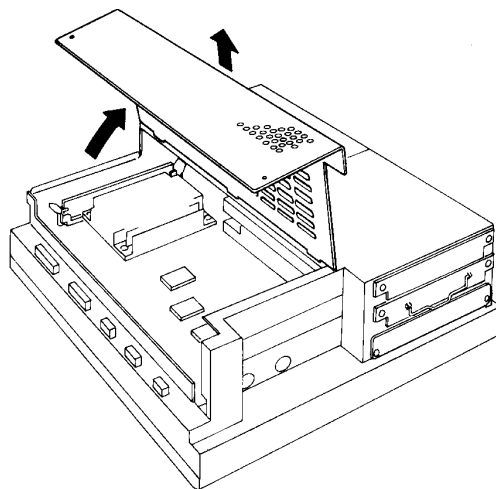

3) Remove the rear maintenance cover.

3.1.2 Installing the DIM Module (PL-EM220 / PL-EM230)



- **Since DIM module sockets are easy to break, be sure to install the DIM module very carefully.**
- **Do not change the factory installed DIM module's socket position.**

The PL comes with a single, 64MB DIM module pre-installed. There is one more empty socket that can be used and the procedures that follow describe how to install a second DIM module in that socket.

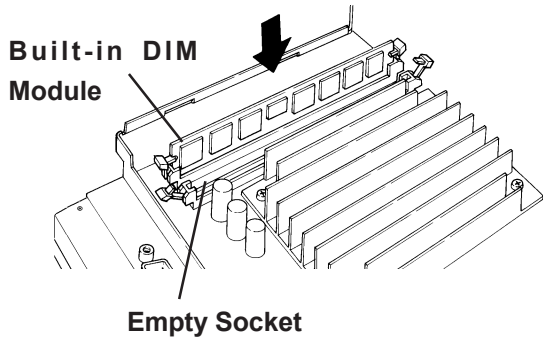

- 1) **Install the DIM expansion module in the empty socket.**

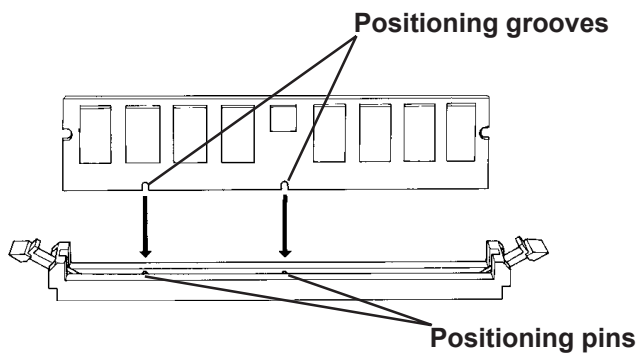

- 2) **Adjust the foolproof positioning grooves so that they align with the foolproof positioning pins.**

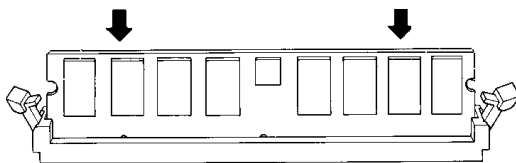

- 3) **Insert the DIM module into the DIM module socket.**

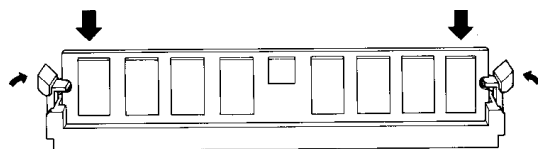

- 4) **Push the DIM module down until the ejector tabs lock.**

- 5) **Replace the rear maintenance cover and the half cover and secure them in place with the attachment**

◆ To Remove the DIM Module

When removing the module from its socket, press down on the socket's ejector tabs to release the module.

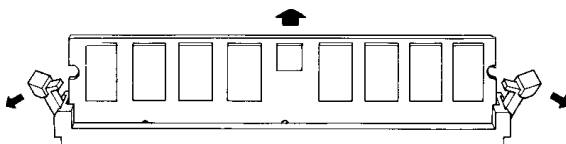

3.1.3 Installing the FDD Unit (PL-FD200)



The PL-FD200 and the PL-FD210 cannot be used at the same time.

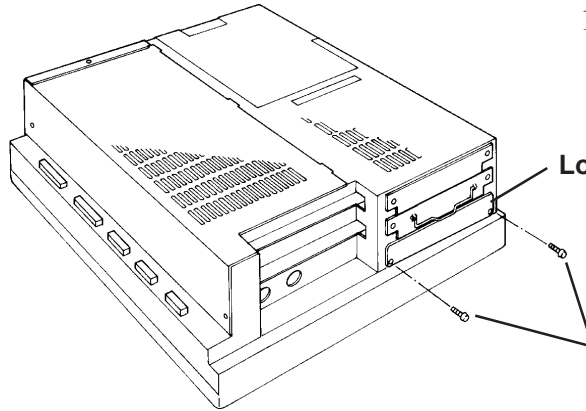

1) Remove the two (2) attachment screws from the lowermost Expansion Slot Cover, and remove the cover.

Lowermost Cover

Attachment Screws

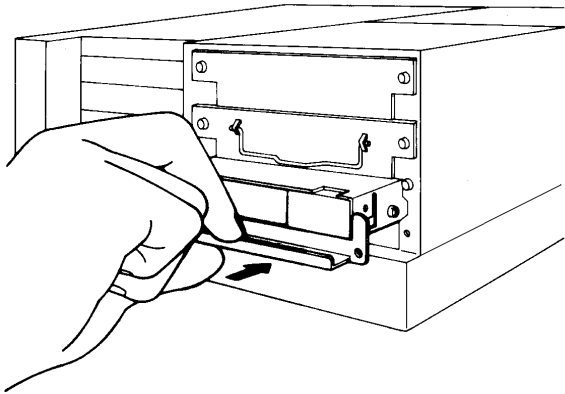

2) Insert the FDD unit so that its guide grooves fit the slot's guide ways. Push the unit in until its rear connector is connected securely.

3) Secure the unit in place with its two(2) attachment screws.

3.1.4 Installing the FDD Unit (PL-FD210)



- The PL-FD-210 can only be used with the PL-B900 and PL-B910 (4-slot type) units, and cannot be used with the PL-B901 and PL-B911 (2-slot type) units.
- The PL-FD200 and the PL-FD210 cannot be used at the same time.

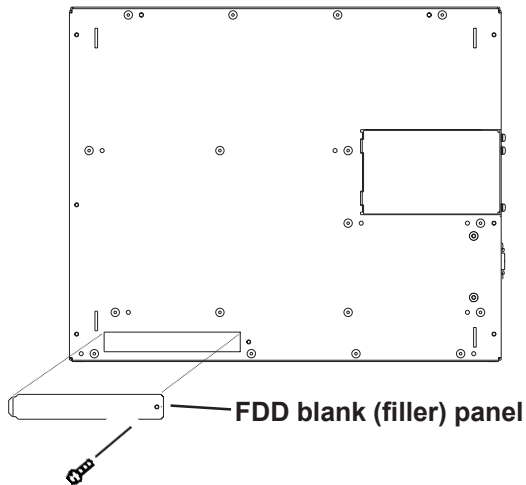

- 1) Unscrew the PL front face's FDD blank panel's attachment screw (1). Remove the blank panel.

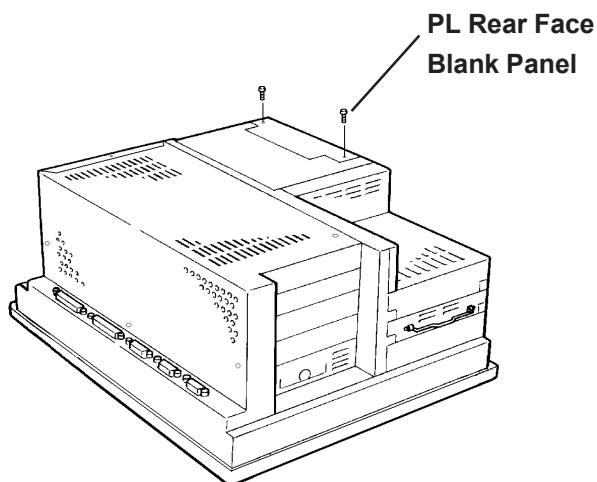

- 2) Unscrew the two (2) attachment screws from the PL's Rear Face Blank Panel, and remove it.

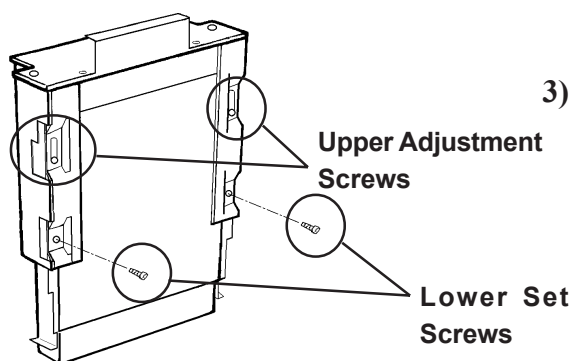

- 3) Loosen the FDD unit chassis two (2) upper adjustment screws, and remove the unit's two (2) lower set screws to allow the FDD unit to slide forward.

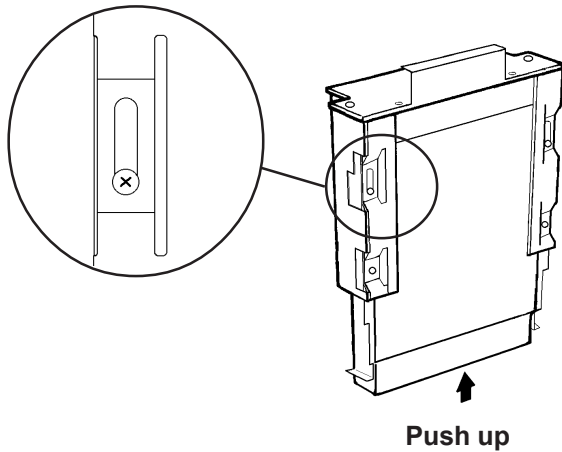

- 4) Push the unit in the direction of the arrow so that the adjustment screw is in the top-most position. Next, secure the unit in place by tightening all four (4) (upper and lower) screws.

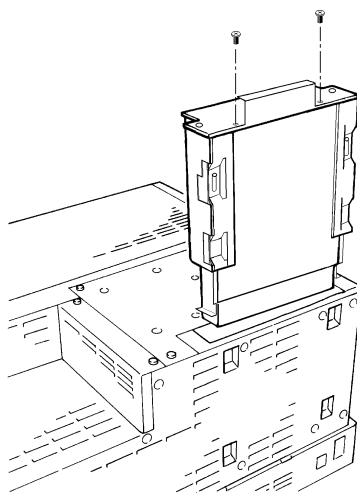
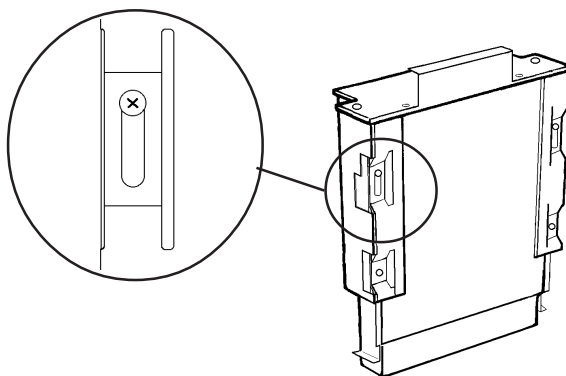

- 5) Insert the FDD unit so that its guide grooves fit the chassis holder's guideways. Push the unit into the holder until its connector (middle of unit) is connected securely.



When installing the PL-FD210, insert it slowly into the PL's installation opening and be sure it is securely attached.

- 6) Fix the unit in place with its two(2) attachment screws.
- 7) Last, replace the Blank Panel (removed in step 3).

3.1.5 Removing/ Installing the HDD Unit (PL-HD2*0)



Note:

- The following insertion/removal procedure is applicable also to the FFD(PL-FF200) unit and the HDD unit.
- Certain usage limitations apply to the HDD, FFD, Mirror Disk and CD-ROM Drive.

Reference *1.3 Optional Items*



Since the HDD unit is a precision instrument, be sure not to jar or shake it unnecessarily.

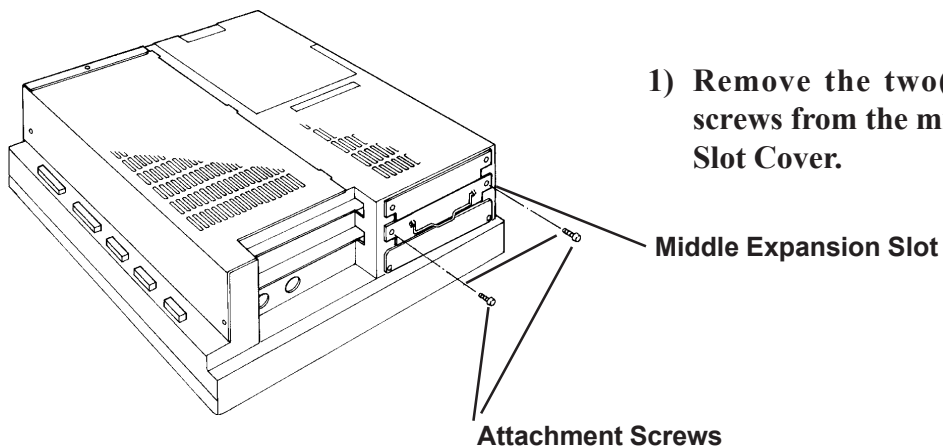

- 1) Remove the two(2) attachment screws from the middle Expansion Slot Cover.

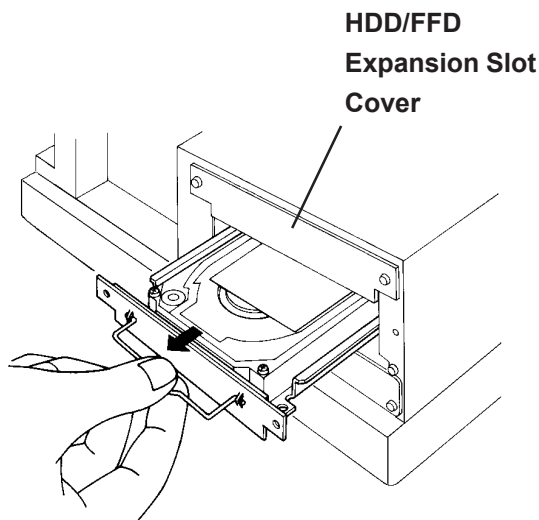

- 2) Grasp the HDD unit's handle and pull the unit slowly out of the PL. Be sure you do not damage the unit.

- 3) Insert the new HDD unit into the PL's guideways and push it in until its rear connector is securely connected.

- 4) Fix the unit in place with its two(2) attachment screws.



Note:

Reattach the Expansion Slot cover using the same steps.

3.1.6 Installing an Expansion Board

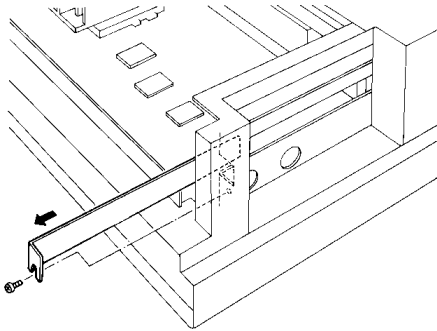

- 1) Unscrew the desired expansion slot's cover attachment screw, and remove the cover.

Reference 3.1.1, *Removing the Rear Maintenance Cover*

Unscrew the Blank Panel's attachment screw to remove the Blank Panel.

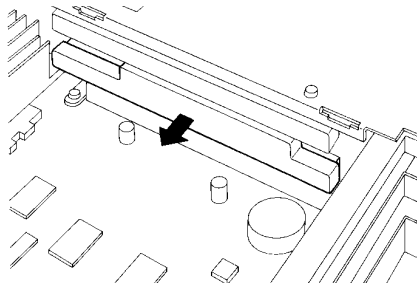

- 2) Remove the expansion slot's duster cover.

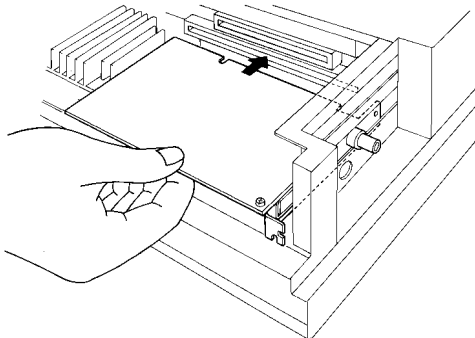

- 3) Insert the expansion board into the expansion slot.

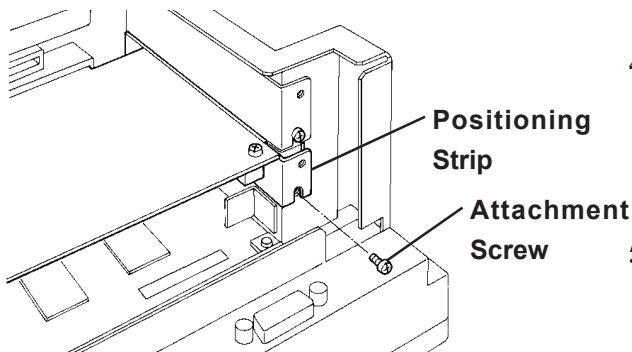

- 4) Secure the expansion board's metal positioning strip in place with its attachment screw.

- 5) Last, replace the rear maintenance cover and half cover and secure them in place with their attachment screws.

3.1.7 Connecting the CD-ROM Unit (PL-DK200)

When using the CD-ROM unit, be sure to change the System Information area's "Integrated Peripherals" [IDE Primary Master PIO] and [IDE Primary Slave PIO] settings to [Mode 2], or set [IDE Primary Master UDMA] or [IDA Primary Slave UDMA] to [Disabled]. **Reference** 5.2.9 *Integrated Peripherals*.

■ PL-B900 Unit

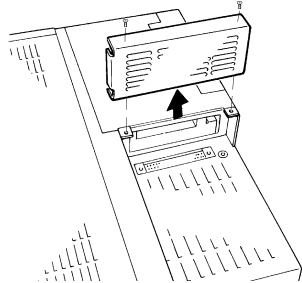

- 1) Unscrew the two(2) IDF I/F cover's attachment screws, and remove the cover.

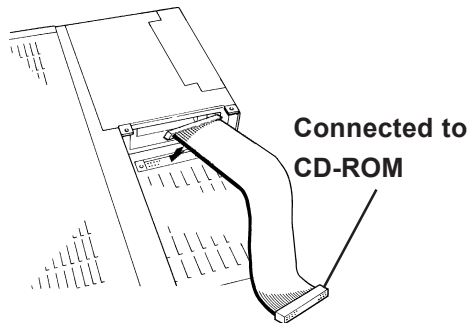

- 2) Connect the CD-ROM unit cable to the PL's IDF I/F connector.



Be sure that the cable is securely connected before turning ON the PL's power switch.

■ PL-B901 Unit

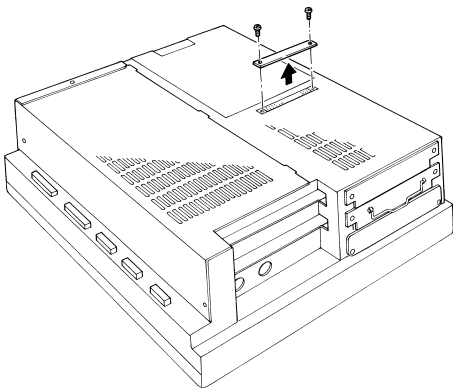

- 1) Unscrew the two(2) IDF I/F cover attachment screws, and remove the cover.

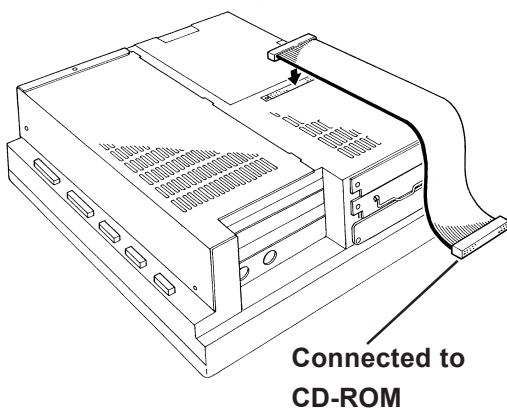

- 2) Connect the CD-ROM unit's cable to the IDF I/Fconnector.



Be sure that the cable is securely connected before turning ON the PL's power switch.

3.1.8 Attaching the Display Expansion Board (PL-PE200)

- 1) Unscrew the PL's two (2) Attachment Screws and remove Cover A. (outermost cover)



Be sure to place the PL unit on a flat, level surface prior to installing the PL-PE200. This will prevent damage to the PL and the accidental cutting of any of its power cord terminals.

- 2) Unscrew the three (3) Attachment Screws and remove Cover B. (inner cover)

- 3) After checking that the PL and the PL-PE200 connectors are correctly aligned, insert the PL-PE200's three (3) attachment screws removed in step 2) and secure the unit in place.



- ***Be sure to handle the Display Expansion Board carefully since it contains precision components.***
- ***Be sure to insert the Board into place carefully, using only the necessary amount of force.***

- 4) Reattach Cover A and secure it in place with its two (2) Attachment Screws.

3.1.9 Connecting the Standard Display (DU-6900/DU-7900)

■ Connecting a Single Display

Use the PL-CB200-10M Display Cable to connect the PL's Standard Display Connector to the DU unit's connector.

Choose your display cable from the following table.

PL Type	Display Cable
PL-B900/PL-B901 (PL-B900 Series)	PL-CB200-5M PL-CB200-10M
PL-B910/PL-B911 (PL-B910 Series)	PL-CB200-5M

■ Connecting Dual Displays (PL-B910 Series only)

Use the PL-CB200-5M Display Cable to connect the Display Expansion Board's connector to the two DU display units.

1.2.1 Connecting the Dual Displays

◆ Star Configuration

When using 1 DU unit:

Use Digital's Standard Display Cable (5m) to connect the PL's Standard Display connector to the DU unit's connector.

When using 2 DU units:

Use the Standard Display Cable (5m) to connect the PL's Display Expansion Board connector to the DU unit's connector.

◆ Daisy Chain Configuration

When using 1 DU unit:

Use Digital's Standard Display Cable (5m) to connect the PL's Standard Display connector to the DU unit's connector.

When using 2 DU units:

Use the Standard Display Cable (5m) to connect the first DU's Display Expansion Board connector to the second DU unit's PL connector.



Note:

- Be sure not to bend, crimp or pull the PL's Standard Display Cable.
- Be sure to insert the cable connectors together until they lock securely.

3.1.10 Connecting an Analog RGB Monitor

The following explanation connects the PL to a commercially available CRT monitor, or to the Flat Panel (FP) display.

■ Connecting a CRT Monitor

When connecting the CRT monitor, be sure that it is a standard analog multiscan VGA compliant type.

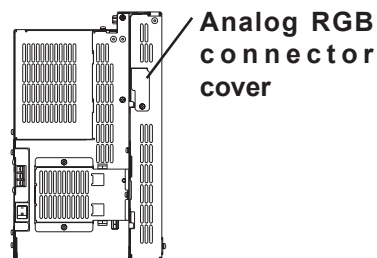

- 1) Unscrew the Analog connector cover's attachment screw, and remove the cover.
- 2) Connect the CRT monitor's cable to the PL's analog RGB connector.

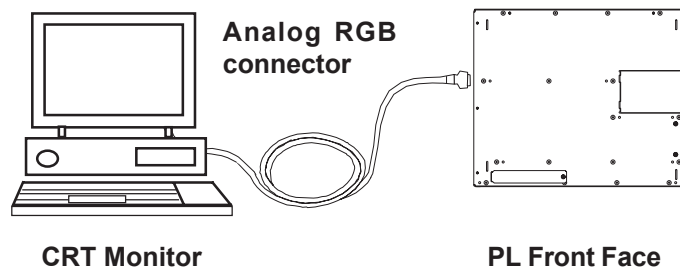

■ Connecting the FP-570

Digital's FP-570 monitor can also be connected to the PL unit. For connection details, **Reference** *FP-570 Series User Manual*.



When the FP is connected to a PL-B910/PL-B911 (PL-B910 series) unit, the touch panel cannot be used, only the display.

When the FP is used, the user's system or OS must be set up first.

Please perform the following steps.

- 1) Connect a standard CRT monitor.
- 2) Perform the specified system setup **Reference** *Chapter 5 - System Setup*
- 3) Set up the OS **Reference** *Chapter 6 - Setting Up Your PL OS*
- 4) Designate the Display (Output) device.

This is performed via the Control Panel's [Screen] settings. Open the [Screen Properties] dialog box and designate the display device as CRT.



If the incorrect display (output) device is designated, simply press the [ESC] key and cancel the settings. If cancelling is not possible, contact your local PL distributor for assistance.

- 5) Shut down the OS.
- 6) Connect the FP-570.
- 7) Restart the OS.

3.1.11 Removing the Cooling Fan Unit

The PL units can be operated without their bottom face cooling fan unit. The user should, however, be aware that doing so (i.e. removing the fan unit) will cause the PL's ambient temperature to rise. **Reference** "2-1-2 Environment Specifications"

■ PL-B900/PLB910 Unit

- 1) Remove the cooling filter cover's attachment screw.

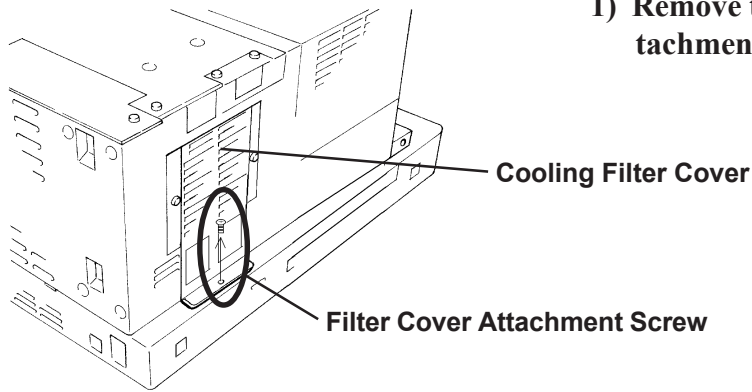

- 2) Remove the cooling filter cover from the fan unit, and then remove the fan unit's two attachment screws.

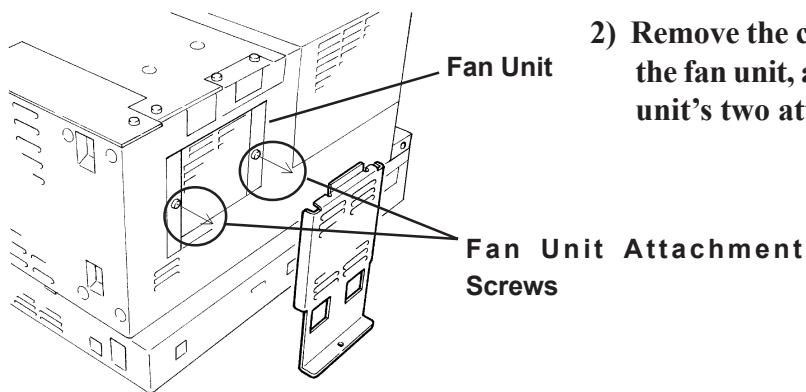

- 3) Remove the fan unit from the PL.

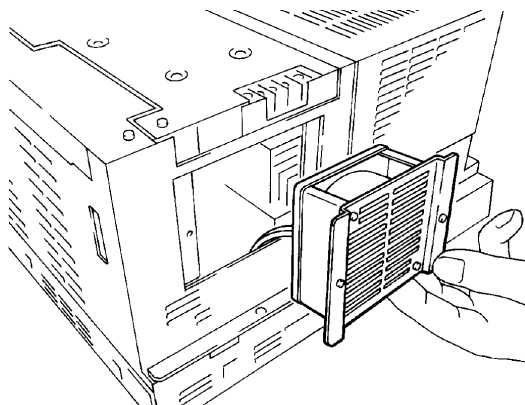

Power Cable Connector

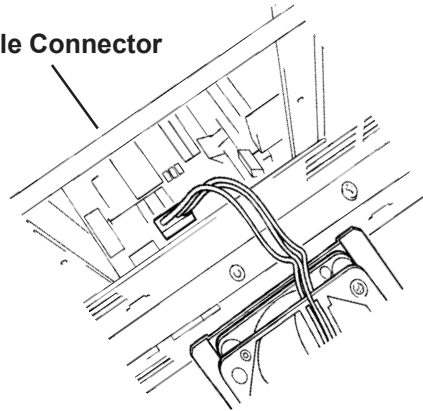

4) Disconnect the fan unit's power cable

5) Replace the cooling filter cover and re-attach the cooling filter cover's attachment screw.

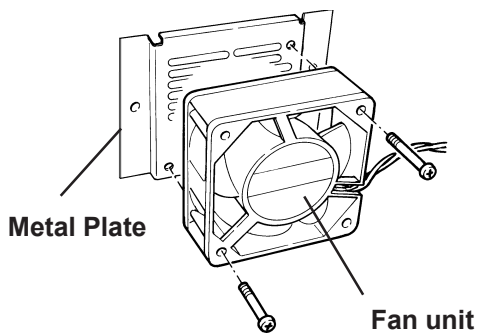

6) Unscrew the two(2) fan unit's attachment screws and remove the fan unit from the metal plate holding the fan unit.

7) Attach the metal plate and the cooling filter cover to the PL.

■ PL-B901/PLB911 Unit

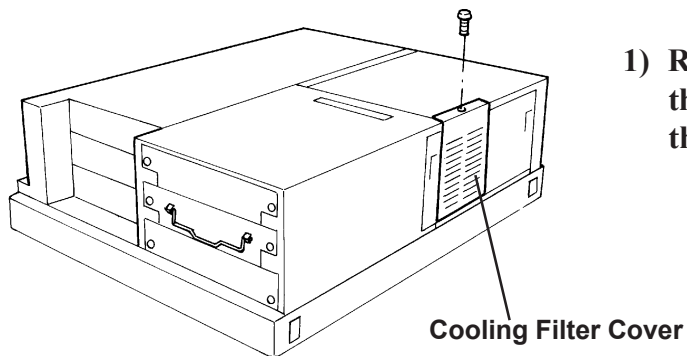

1) Remove the attachment screw on the cooling filter cover, and remove the cover.

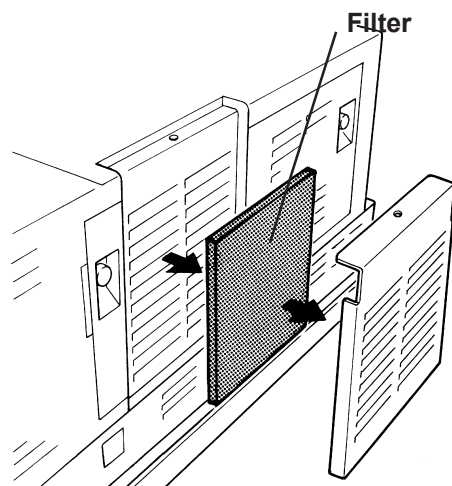

2) Remove the filter.

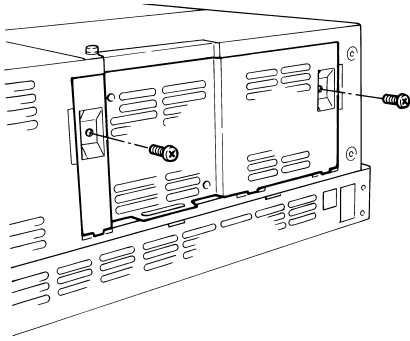

3) Remove the two(2) fan unit attachment screws, and take out the fan unit.

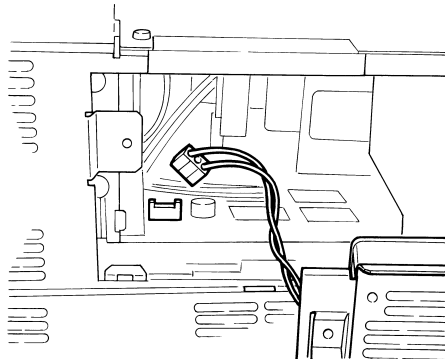
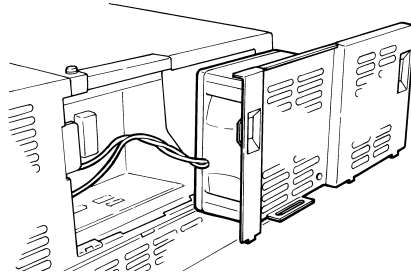

4) Unplug the fan unit's power cable connector from the PL.

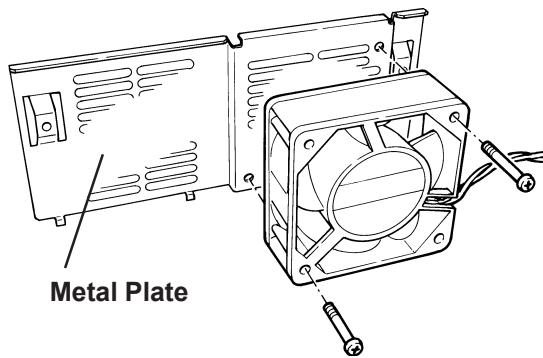

5) Unscrew the two (2) attachment screws and remove the fan unit, and then remove the fan unit from the metal plate.

6) Secure the metal attachment plate and the cooling filter cover to the PL in place.

Chapter

4 Installation and Wiring

4-1 Installation Cautions

4-2 Installing the PL

4-3 Wiring the PL

This chapter explains how to install and wire the PL-B900/PL-B910 series units, as well as the cautions required both before and during installation.

4.1 Installation Cautions

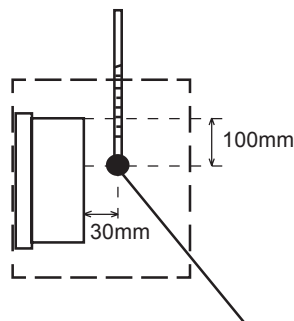

Temperature Sensor
5°C to 50°C (with fan)
5°C to 40°C (without fan)

1) Temperature Related Cautions

- The PL should be installed in a vertical position, and forced air cooling should be used, instead of natural air circulation.
- Be sure to confirm that the area near the PL will be within the allowable temperature range by placing a temperature sensor in the location shown in the left-side drawing. If this area's temperature exceeds the allowed limit, a machine breakdown can occur.



Vertical Installation

Horizontal Installation

2) Installation Positioning Cautions

Be sure to install the panel in an upright (vertical) position.

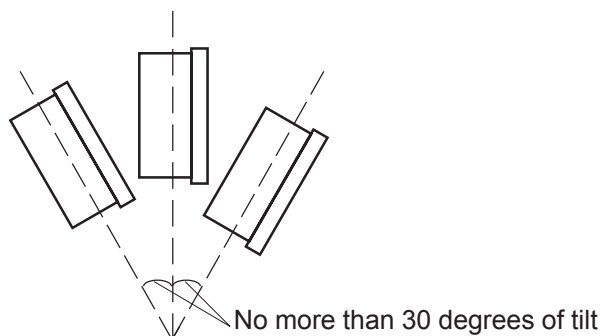

Also, be sure that the panel's viewing angle is tilted no more than 30 degrees from parallel to the operator (i.e. directly in front).

■ **Installation Location**

- Avoid placing the PL next to other devices that might cause overheating.
- Keep the PL away from arc-generating devices such as magnetic switches and non-fuse breakers.
- Avoid using the PL in environments where corrosive gases are present.
- To ensure the reliability, operability and ventilation of the PL, be sure to install it in locations that are more than 50mm away from adjacent structures or equipment. Also, consider the need for installing or removing expansion boards, or connectors when designing and installing your PL.

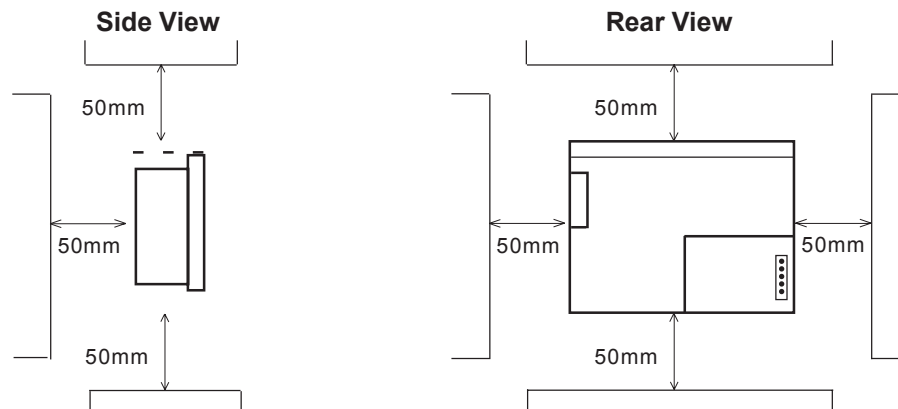

■ **Vibration and Shocks**

If the PL is moved when its enclosure doors are open, or while it is installed in a rack equipped with caster wheels, the hard disk can receive excessive vibration or jolting. Be especially careful at this time.

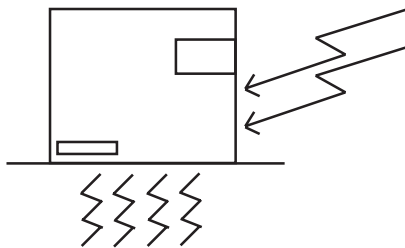

PL Configuration	Can Withstand
HDD	Up to 4.9m/s ²
FDD	Up to 9.8m/s ²
No drives	Up to 19.6m/s ²



- **The Hard Disk Drive is precision equipment and should not be moved or jolted . Especially when the PL is turned ON, even changing the PL's direction while it is on a table, or repositioning the unit should not be performed, since it can lead to a hard disk crash or malfunction.**
- **When using a fan to cool the PL unit, be sure that the fan does not point directly at any of the PL's disk drive units, since it can lead to a hard disk crash or malfunction.**

4.2 Installing the PL

4.2.1 Installation Procedures

Use the following procedures to install the PL into a solid panel.



Be sure to read the previous section's Installation Cautions in order to install the PL safely.



When using the optional 19 inch Mount Panel, refer to the PL-RM200 unit's Installation guide for details.

- 1) Use the six (6) attachment screws included in the PL's packing box to attach the mounting brackets to the PL main unit. Be careful to attach each side's bracket to the correct side.

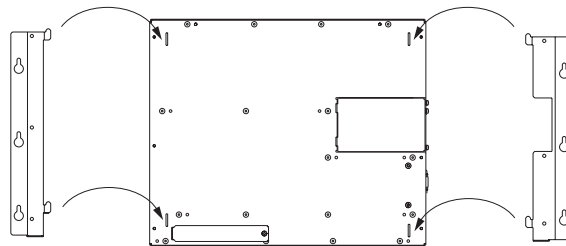

- 2) Drill the attachment holes in the Installation Panel. Be sure to follow the dimensions given for the attachment holes.

Reference 2.5.3 Full Sized Cover Attachment Dimensions

- 3) Attach the PL to the Installation Panel with M4 screws.

First, insert the main unit attachment screws into the Installation Panel's holes, but do not tighten them. Then, place the PL main unit on the panel so that the bracket holes and the screw heads align. Last, slide the PL down so that the main unit is supported by the main unit attachment screws. Tighten the screws until the PL is secured in place.



Be sure to not use too much force when tightening the main unit attachment screws. The torque required is from 0.5 to 0.6N•m.

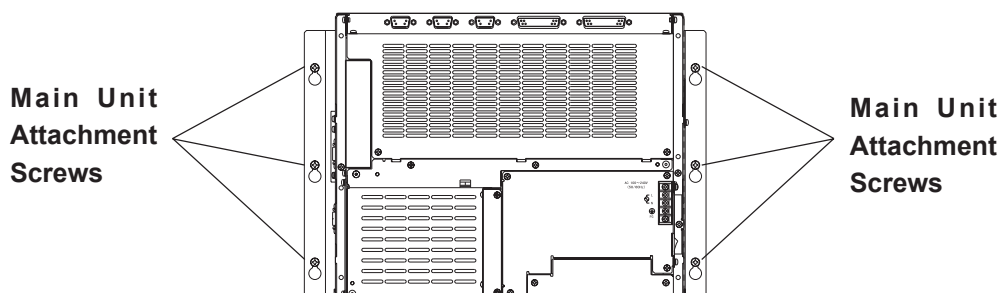

4.3 Wiring the PL

4.3.1 Connecting the Power Cord

Connect the PL's power cord to the PL's rear face power terminals.

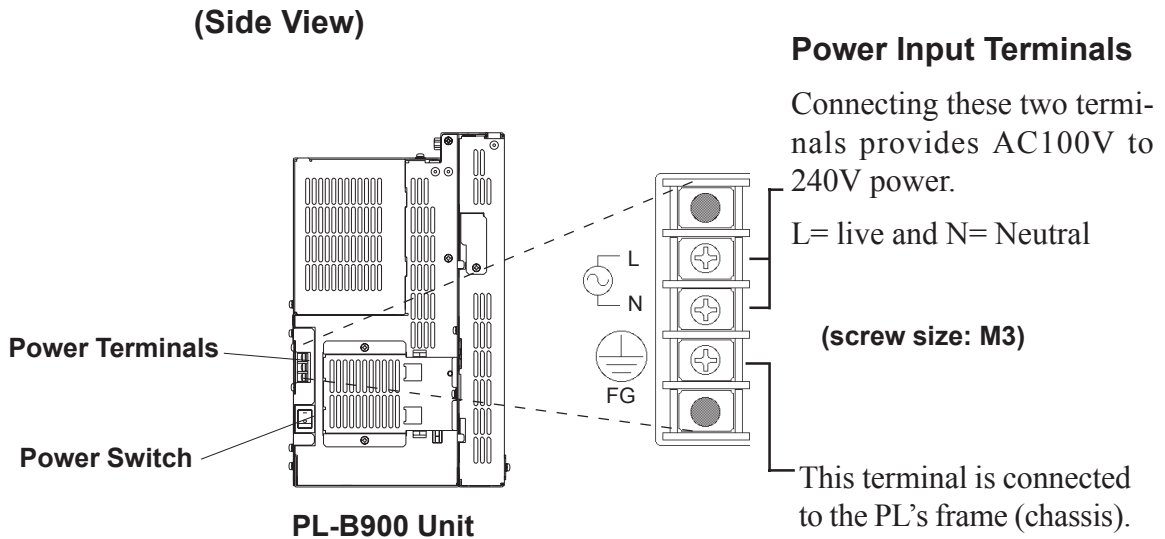

Use the following steps when connecting the power cord to the PL's power terminals.



WARNING

- To prevent electric shocks, be sure to turn the PL OFF before connecting the power cord terminals to the PL.
- To avoid the dangers of fire, electrical hazards and equipment damage, be sure to use only the specified power supply voltage when operating the PL.

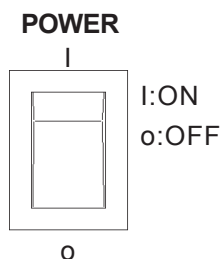

- 1) Confirm that the PL's power switch is turned OFF. Then, remove the power terminal's transparent plastic cover.

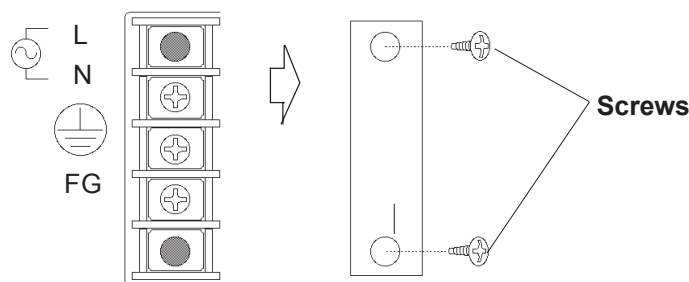

Transparent Cover

Installation and Wiring

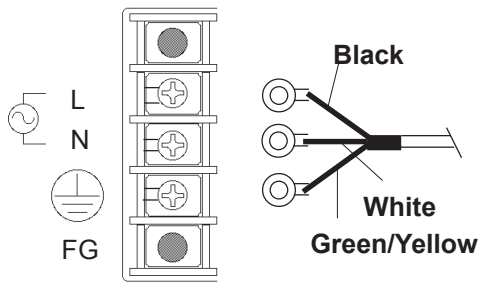

- 2) Loosen and remove the middle three screws from the terminal strip. Align the crimp terminals with each screw hole, and tighten the screws.



Note:

- Crimp Terminal Types : V1.25-3, by J.S.T. or equivalent (JIS standard part number : RAV1.25-3)

- Crimp terminals must be the same as shown below.

Max. 6.0 mm  ϕ 3.2 mm or larger



- **The colors used in these figures are for the cable which came with the PL.**

- **This power cable is designed only for AC100V/115V use. When using other than AC100V/115V power, use a cable that is designed specifically for that level of power.**

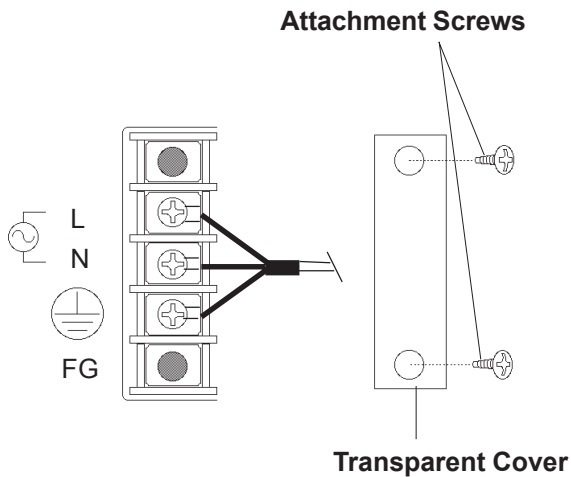

- 3) Reattach the terminal strip's transparent cover and secure it in place with its attachment screws.

4.3.2 Power Supply Cautions

When connecting the PL unit's AC power terminals, please be aware of the following:

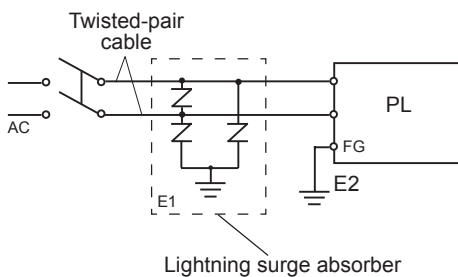
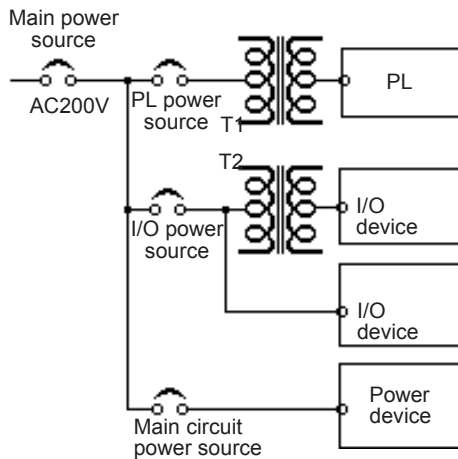
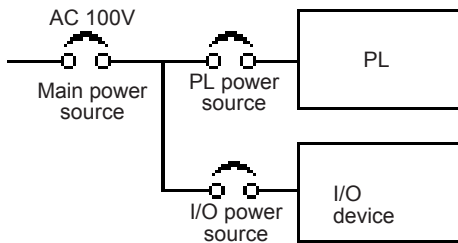
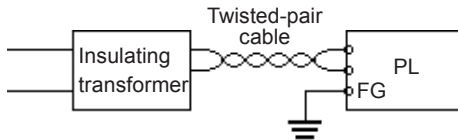
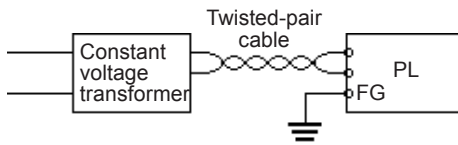

- If voltage fluctuations are expected to vary beyond the specified range, connect a constant voltage transformer.

Reference For information about the specified voltage, refer to **2-1 General Specifications**

- Use a low-noise power supply both between the lines and between the PL and its ground. If there is still excess noise, connect an insulating transformer (noise-prevention type).

Note: Be sure any constant or insulating transformer used has a capacity of 200VA or more.

- Wire the power cords of the PL, I/O devices, and power supply devices separately.

- To improve noise immunity, it is recommended to attach a ferrite core to the power cord.
- Isolate the main circuit (high voltage, large current) line, I/O signal lines, and power cord, and do not bind or group them together.

- To prevent damage from lightning, connect a lightning surge absorber.



- **Ground the lightning surge absorber (E1) and the PL (E2) separately.**
- **Select a lightning surge absorber which will not exceed the allowable circuit voltage, even when the voltage rises to the maximum.**

4.3.3 Grounding Cautions

(a) Dedicated Ground - best ^{*1}



- Set up a dedicated ground when using the rear panel's FG terminal.

(b) Shared Ground - allowed ^{*1}

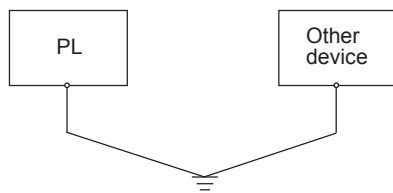

- If a dedicated ground is not possible, use a shared ground, as shown in figure (b).
- The grounding point must be as close to the PL as possible, and the grounding wires must be as short as possible. If the wires must be long, use thick, insulated wires and run them through conduits.

(c) Shared ground - not allowed

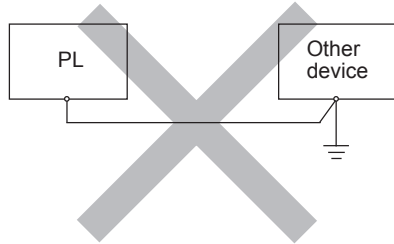

4.3.4 Cautions When Connecting I/O Signal Lines

- I/O signal lines must be wired separately from charged lines. If the power cord needs to be wired together with the (I/O) signal lines for any reason, use shielded lines and ground one end of the shield to the PL's FG terminal.
- To improve noise immunity, attaching a ferrite core to the power cord is recommended.

^{*1} Use a grounding resistance of less than 100 Ω and a 2mm² or thicker wire, or your country's applicable standard. For details, contact your local PL distributor.

Memo

Chapter

5 System Setup

5-1 Setup Procedures

5-2 System Parameters

5.1 Setup Procedures

This chapter explains how to enter a PL unit's system settings, as well as the cautions required both before and during set up.



Note: The following settings are those pre-set at the factory.

- 1) Attach the PL and its DU unit or an RGB monitor.
- 2) Connect a PS/2 keyboard to the PL.
- 3) Turn the PL, and the DU or the Analog monitor's power ON.
- 4) After the message "Press to Enter SETUP" appears, press the [DEL] key until the following screen is displayed.

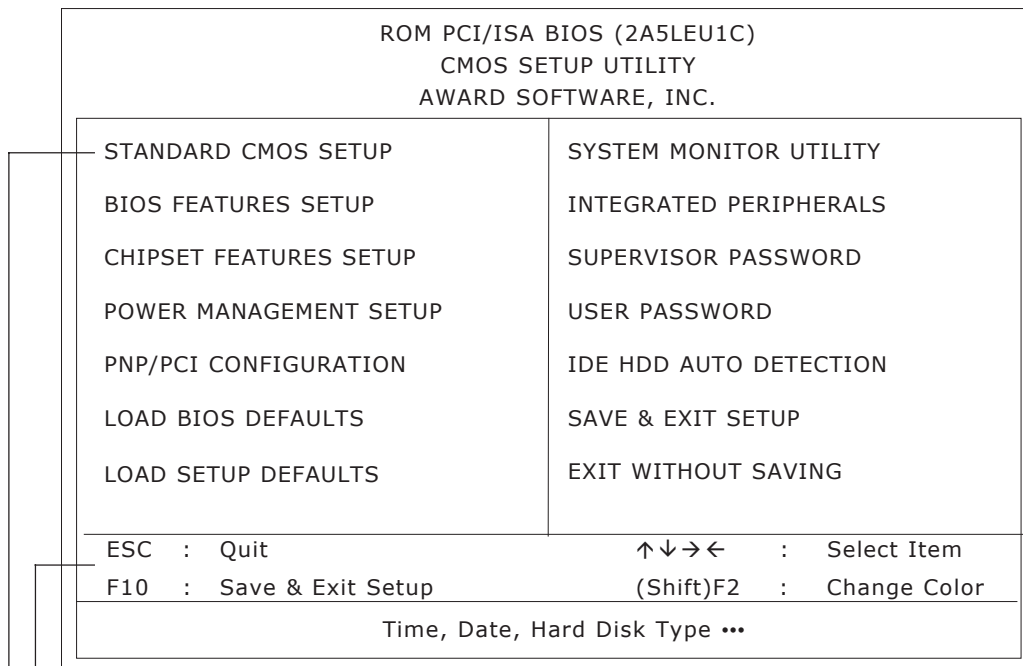

KEYBOARD ACTION KEYS

Provides a summary of the keyboard keys used to carry out the set up.

SYSTEM SETTING SELECTION AREA

Each of the titles (areas) listed here contains system setting items.

- 5) Use the arrow keys to move the cursor to the desired selection and use the [Enter] key to select an item.

5.2 System Parameters

Use the menu screen to select a System Item, and then enter the desired system information. Each item's detailed settings are shown here.



Normally, use only the factory (default) settings.

5.2.1 STANDARD CMOS SETUP

Selecting the STANDARD CMOS SETUP menu item produces the following screen.

ROM PCI/ISA BIOS(2A5LEU1C)						
STANDARD CMOS SETUP						
AWARD SOFTWARE, INC.						
Date (mm:dd:yy): Thu,Jul 2 2000						
Time (hh:mm:ss): 14 : 50 : 3						
		CYLS.	HEADS	PRECOMP	LANDZONE	SECTORS MODE
Drive C	:Auto(0Mb)	0	0	0	0	AUTO
Drive D	:Auto(0Mb)	0	0	0	0	AUTO
Drive A	:1.44M,3.5 in.					
Video :	EGA/VGA					Base Memory : 640K
VGA Text Mode :	Normal					Extended Memory : 645612K
VGA Graphics Mode :	Normal					Other Memory : 384K
Halt On :	All, But Disk/Key					Total Memory : 66536K
ESC :	Quit	↑↓→←	:	Select Item	PU/PD/+/-	: Modify
F1 :	Help	(Shift)F2	:	Change Color		

** The above settings are factory settings.*

■ Date/Time

This data sets the PL's internal time and date.

Hours :00 - 23
 Minutes :00 - 59
 Seconds :00 - 59

■ Drive C

This data sets the IDE hard disk's parameters. When this setting is set to [AUTO], the hard disk's parameters are automatically read in. Also, if the "IDE HDD AUTO DETECTION" is in use, the value entered there is automatically set. The three options are [User],[Auto], and [None]. The [Auto] setting is factory set and recommended for most users.

■ Drive D

The three options are [User],[None]and [Auto].

■ Drive A

This setting determines the format used by the PL's internal floppy disk drive. The[1.44M - 3.5in] selection is factory set and recommended for most users. The other available settings are [720K - 3.5in], [1.2M - 5.25in], [360K - 5.25in], [2.88M - 3.5in.], and [None].

System Setup

■ Video

The selections for the screen (video) mode. The [EGA/VGA] selection is factory set and recommended for most users. The other available settings are [CGA40], [CGA80] and [Mono].

■ VGA Text Mode

This mode changes the screen (video) mode from [Normal](VGA mode) to [Expansion](800×600). The [Normal] selection is factory set and recommended for most users.

■ VGA Graphics Mode

This mode changes the screen (Graphics) mode from [Normal](VGA mode) to [Expansion](800×600). The [Normal] selection is factory set and recommended for most users.

■ Halt On

Designates the type of processing that will be performed when an error occurs during the Initial Start-Up's Self Test. The [All But Disk /Key] selection is factory set and recommended for most users.

- [All Errors] : Displays all errors and stops the unit.
- [No Errors] : Displays all errors and does not stop the unit.
- [All,But Keyboard] : Displays all errors, except for those related to the keyboard, and stops the unit. If the User has no keyboard connected, please use this setting.
- [All,But Diskette] : Displays all errors, except for those related to the disk drive (FDD), and stops the unit.
- [All,But Disk/Key] : Displays all errors, except for those related to the disk drive (FDD) and keyboard, and then stops the unit.

5.2.2 BIOS FEATURES SETUP

Selecting the BIOS FEATURES SETUP menu item calls up the following screen.

ROM PCI/ISA BIOS(2A5LEU1C)			
BIOS FEATURES SETUP			
AWARD SOFTWARE, INC.			
Virus Warning	:Disabled	Video BIOS Shadow	: Enabled
CPU Internal Cache	:Enabled	C8000-CBFFF Shadow	: Disabled
External Cache	:Enabled	CC000-CFFFF Shadow	: Disabled
Quick Power On Self Test	:Enabled	D0000-D3FFF Shadow	: Disabled
Boot Sequence	:A,C,SCSI	D4000-D7FFF Shadow	: Disabled
Boot Up Floppy Seek	:Enabled	D8000-DBFFF Shadow	: Disabled
Boot Up NumLock Status	:On	DC000-DFFFF Shadow	: Disabled
Boot Up System Speed	:High		
Gate A20 Option	:Fast		
Memory Parity/ECC Check	:Enabled		
Typematic Rate Setting	:Disabled	ESC :Quit	↑ ↓→← : Select Item
Typematic Rate(Chars/Sec)	:6	F1 : Help	PU/PD/+/- : Modify
Typematic Delay (Msec)	:250	F5 : Old Values	(Shift)F2 : Color
Security Option	:Setup	F6 : Load BIOS Defaults	
PCI/VGA Palette Snoop	:Disabled	F7 : Load Setup Defaults	
OS Select For DRAM > 64MB	:Non-OS2		

* The above settings are factory settings.

■ Virus Warning

Designates whether a warning message appears when an error occurs during a write to the Hard Disk's Boot Sector. The two selections are [Disabled] and [Enabled]. The [Disabled] selection is factory set and recommended for most users.

■ CPU Internal Cache

Designates if the CPU's Internal Cache Memory is used or not. The two selections available are [Disabled] and [Enabled]. The [Enabled] selection is factory set and recommended for most users.

■ External Cache

Designates if the CPU's External Cache Memory (L2) is used or not. The two selections available are [Disabled] and [Enabled]. The [Enabled] selection is factory set and recommended for most users.

■ Quick Power On Self Test

Designates if a simplified Self Test is used after the power is turned ON. The two selections available are [Disabled] and [Enabled]. The [Enabled] selection is factory set and recommended for most users.

■ Boot Sequence

Designates the drive order used by the OS during start up.

The [A,C,SCSI] is factory set and recommended for most users. The other available settings are [A,C,SCSI], [C,A,SCSI], [C,CDROM,A], [CDROM,C,A], [D,A,SCSI], [SCSI, A,C,], [SCSI,C,A] and [C Only].

System Setup

■ **Boot Up Floppy Seek**

Designates if the floppy disk drive installation check is used or not. The available selections are [Disabled] and [Enabled]. [Enabled] is factory set and recommended for most users.

■ **Boot Up NumLock Status**

Designates the condition of the NumLock key at startup. The two selections are either [On] or [Off]. The [On] selection is factory set and recommended for most users.

■ **Boot Up System Speed**

Designates the speed of CPU. [High] is factory set and recommended for most users. The other available selection is [Low].

■ **Gate A20 Option**

The two selections available are [Fast] and [Normal]. When [Normal] is selected, Keyboard Control is used for Gate A20 control. When [Fast] is selected, the Chipset is used. The [Fast] selection is factory set and recommended for most users.

■ **Memory Parity / ECC Check**

Designates if a Parity Check is used for Parity Memory. The two selections available are [Disabled] and [Enabled]. The [Enabled] selection is factory set and recommended for most users.

■ **Typematic Rate Setting**

Designates the repeat mode for characters on the keyboard. The selections [Disabled] and [Enabled] are available. [Disabled] is factory set and recommended for most users.

■ **Typematic Rate (Chars/Sec)**

When [Enabled] is selected on [Typematic Rate Setting], it designates the actual rate (the number of repeating characters per second). [6],[8],[10],[12],[15], [20],[24] and [30] are the available selections.[6] is factory set.

■ **Typematic Delay (Msec)**

When [Enabled] is selected on [Typematic Rate Setting], it designates the time until repetition of a character starts. The unit is milli-second (msec). The available selections are [250],[500],[750]and [1000]. [250] is factory set.

■ **Security Option**

Designates the location of the Password Entry. The selection [Setup] is for BIOS setup,and the other selection [System] is for both BIOS setup and Start up. When the [Supervisor Password] or [User Password] has not been designated, this setting is disabled. [Setup] is factory set and recommended for most users.



Choose either the "Supervisor Password" or the "User Password" from the Password menu.

■ **PCI/VGA Palette Snoop**

When the PCI/VGA and the MPEG ISA/VESA VAG cards are both used, this setting is set to [Enabled]. In all other cases, this should be set to [Disabled]. The [Disabled] selection is factory set and recommended for most users.

■ **OS Select For DRAM >64MB**

Select either [Non-OS2] or [OS2]. The [Non-OS2] selection is factory set and recommended for most users.

■ **Video BIOS Shadow**

Designates whether Video BIOS ROM is expanded into RAM and used from there (C0000-C7FFF). The two selections available are [Disabled] and [Enabled]. The [Enabled] selection is factory set and recommended for most users.

■ **C8000-CBFFF Shadow to DC000-DFFFF Shadow**

When the Expansion Board's ROM is placed in this area, this setting designates if the ROM expands into the RAM area. The two available selections are [Disabled] and [Enabled]. The [Disabled] selection is factory set and recommended for most users.

5.2.3 CHIPSET FEATURES SETUP

Selecting the CHIPSET FEATURES SETUP menu item calls up the following screen.

ROM PCI/ISA BIOS(2A5LEU1C) CHOS SETUP UTILITY CHIPSET FEATURES SETUP			
Bank 0/1 DRAM Timing	:70ns	OnChip USB	:Disabled
SDRAM Cycle Length	:3		
DRAM Read Pipeline	:Enabled		
Sustained 3T Write	:Enabled		
Cache Rd+CPU Wt Pipeline	:Enabled		
Cache Timing	:Fast		
Video BIOS Cacheable	:Enabled		
System BIOS Cacheable	:Enabled		
Memory Hole At 15Mb Addr.	:Disabled		
		ESC :Quit ↑ ↓ → ← : Select Item	
		F1 : Help PU/PD/+/- : Modify	
		F5 : Old Values (Shift)F2 : Color	
		F6 : Load BIOS Defaults	
		F7 : Load Setup Defaults	

** The above settings are factory settings. However, with a PL-B900/PLB901 (PL-B900 series) unit, change the [OnChip USB] setting to [Enabled].*

■ **Bank 0/1 DRAM Timing**

Designates the length of time of accessing to the memory set up on the memory slot 0/1. The available selections are [70ns], [60ns], [Normal], [Medium], [Fast] and [Turbo]. [70ns] is factory set and recommended for most users.

System Setup

- **SDRAM Cycle Length**

Designates the length of the cycle time of SDRAM. The available selections are [3] and [2]. [3] is factory set and recommended for most users.

- **DRAM Read Pipeline**

Designates if the DRAM performs the pipeline read. The available selections are [Enabled] and [Disabled], [Enabled] is factory set and recommended for most users.

- **Sustained 3T Write**

Designates if the DRAM performs the write back and the write through in the secondary cache. The available selections are [Enabled] and [Disabled]. [Enabled] is factory set and recommended for most users.

- **Cache Rd+CPU Wt Pipeline**

Designates the length of time of waiting for the cache performance. The available selections are [Enabled] and [Disabled]. [Enabled] is factory set and recommended for most users.

- **Cache Timing**

Designates the access speed of the cache. The available selections are [Fast] and [Fastest]. [Fast] is factory set and recommended for most users.

- **Video BIOS Cacheable**

Designates if the cache performs on the Video BIOS. The available selections are [Enabled] and [Disabled]. [Enabled] is factory set and recommended for most users.

- **System BIOS Cacheable**

Designates if the cache performs on the System BIOS. Using System BIOS speeds up the program operation. The available selections are [Enabled] and [Disabled]. [Enabled] is factory set and recommended for most users.

- **Memory Hole At 15Mb Addr.**

Designates if the memory hole 15MB to 16MB is allocated to the buffer memory for the ISA bus card. The available selections are [15M-16M] and [Disabled]. [Disabled] is factory set and recommended for most users.

- **On Chip USB**

Used for USB type peripheral equipment. The available selections are [Enabled] and [Disabled]. The PL-B910/PL-B911 (PL-B910 Series) units should be set to [Enabled].

- **USB Keyboard Support**

If the "On Chip USB" selection is enabled, this setting designates if a USB type keyboard can be used. The available selections are [Enabled] and [Disabled]. The PL-B910/PL-B911 (PL-B910 Series) units should be set to [Enabled].

5.2.4 POWER MANAGEMENT SETUP

Selecting the POWER MANAGEMENT SETUP menu item calls up the following screen.

ROM PCI/ISA BIOS(2A5LEU1C)	
POWER MANAGEMENT SETUP	
AWARD SOFTWARE, INC.	
Power Management : User Define	Primary INTR : ON
PM Control by APM : No	IRQ3 (COM 2) : Primary
Video Off Option : Suspend→Off	IRQ4 (COM 1) : Primary
Video Off method : V/H SYNC+Blank	IRQ5 (LPT 2) : Primary
MODEM Use IRQ : NA	IRQ6 (Floppy Disk) : Primary
	IRQ7 (LPT 1) : Primary
	IRQ8 (RTC Alarm) : Primary
	IRQ9 (IRQ2 Redir) : Primary
	IRQ10 (Reserved) : Primary
	IRQ11 (Reserved) : Primary
	IRQ12 (PS/2 Mouse) : Primary
	IRQ13 (Coprocessor) : Primary
	IRQ14 (Hard Disk) : Primary
	IRQ15 (Reserved) : Primary
	ESC :Quit ↑ ↓ → ← : Select Item
	F1 : Help PU/PD/+/- : Modify
	F5 : Old Values (Shift)F2 : Color
	F6 : Load BIOS Defaults
	F7 : Load Setup Defaults

** The above settings are factory settings.*

■ Power Management

You can choose from three power management options. These are [User Define], [Min Saving] and [Max Saving]. The [User Define] selection is factory set and recommended for most users.

■ PM Control by APM

Designates if the power management is controlled by the APM. The two selections available are [Yes] and [No]. The [No] selection is factory set and recommended for most users.

■ Video Off Option

Turns the display off. The selections are [Always On], [Suspend→Off], and [All Modes→Off]. [Suspend→Off] is factory set and recommended for most users.

■ Video Off Method

Designates the method of turning the display off. The available selections are [V/H SYNC+Blank], [Blank Screen] and [DPMS Support]. To turn off both the display and the Vertical / Horizontal synchronous signal, select [V/H SYNC+Blank]. To turn off the display only, select [Blank Screen]. Select [DPMS support] when the CRT display is supported by DPMS. [V/H SYNC+Blank] is factory set and recommended for most users.

System Setup

■ MODEM Use IRQ

Selections for this feature include [NA],[3],[4],[5],[7],[9][10], and [11]. The [NA] selection is factory set and recommended for most users.

■ HDD Power Down

Designates the length of time until the motor of the hard disk stops. The available selections are [1Min]→[15Min] and [Disabled]. [10Min] is factory set and recommended for most users.

■ Doze Mode

When there is no reply from the system within designated time, by using this mode the CPU operation will be automatically stopped. [Disable] is factory set and recommended for most users.

■ Suspend Mode

When there is no reply from the system within designated time, by using this mode all peripheral equipment operation will be stopped. [Disable] is factory set and recommended for most users.

■ VGA

Designates if the system is turned on when any event is driven in the VGA port. The available selections are [ON] and [OFF]. [OFF] is factory set and recommended for most users.

■ LPT & COM

Designates if the system is turned on when any event is driven in the serial port or the printerport. The available selections are [None], [LPT], [COM] and [LPT /COM]. [LPT/COM] is factory set and recommended for most users.

■ HDD & FDD

Designates if the system is turned on when any event is driven in the hard disk or floppy disk. The available selections are [ON] and [OFF]. [ON] is factory set and recommended for most users.

■ DMA / master

Designates if the system is turned on when any event is driven in the DMA controller. The available selections are [ON] and [OFF]. [OFF] is factory set and recommended for most users.

■ Primary INTR

Designates if the system is turned on when any event is driven in the Primary Interrupt Controller. The available selections are [ON] and [OFF]. [ON] is factory set and recommended for most users.

■ IRQ3-IRQ15

Designates if the COM Port is monitored or not. The available selections are [Disabled], [Primary] and [Secondary].

5. 2. 5 PNP/PCI CONFIGURATION SETUP

Selecting the PNP/PCI CONFIGURATION SETUP menu item displays the following screen.

ROM PCI/ISA BIOS(2A5LEU1C)	
PNP/PCI CONFIGURATION	
AWARD SOFTWARE, INC.	
PNP OS Installed	: No
Resources Controlled By	: Manual
Reset Configuration Data	: Disabled
ACPI I/O Device Node	: Enabled
IRQ-3 assigned to	: Legacy ISA
IRQ-4 assigned to	: Legacy ISA
IRQ-5 assigned to	: PCI/ISA PnP
IRQ-7 assigned to	: Legacy ISA
IRQ-9 assigned to	: Legacy ISA
IRQ-10 assigned to	: Legacy ISA
IRQ-11 assigned to	: PCI/ISA PnP
IRQ-12 assigned to	: Legacy ISA
IRQ-14 assigned to	: Legacy ISA
IRQ-15 assigned to	: PCI/ISA PnP
DMA-0 assigned to	: PCI/ISA PnP
DMA-1 assigned to	: PCI/ISA PnP
DMA-3 assigned to	: PCI/ISA PnP
DMA-5 assigned to	: PCI/ISA PnP
DMA-6 assigned to	: PCI/ISA PnP
DMA-7 assigned to	: PCI/ISA PnP
CPU to PCI Write Buffer	: Enabled
PCI Dynamic Bursting	: Enabled
PCI Master 0 WS Write	: Enabled
PCI Delay Transaction	: Enabled
PCI Master Read Prefetch	: Enabled
PCI#2 Access #1 Retry	: Disabled
PCI IRQ Activated By	: Level
Assign IRQ For USB	: Disabled
ESC: Quit	↑↓→← :Select Item
F1 : Help	PU/PD/+/-:Modify
F5 : Old Values	(Shift)F2:Color
F6 : Load BIOS Defaults	
F7 : Load Setup Defaults	

** The above settings are factory settings.
However, with a PL-B910/PL-B911 (PL-B910 series) unit,
change the [Assign IRQ for USB] setting to [Enabled].*

■ PNP OS Installed

Setting used when the user's OS complies with Plug-And-Play standards. The selection options are either [Yes] or [No]. The [No] setting is factory set and recommended for most users.

■ Resources Controlled By

The Plug and Play feature allows you to designate whether the allocation of I/O Port, IRQ and DMA resources is performed automatically or manually. The two selections available are [Manual] and [Auto]. The [Manual] selection is factory set and recommended for most users.

■ Reset Configuration Data

Designates whether ESCD (Extended System Configuration Data) data should be erased or not. The two selections available are [Disabled] and [Enabled]. The [Disabled] selection is factory set and recommended for most users.

■ ACPI I/O Device Node

When an I/O device is connected to the PL that is ACPI compliant, the PL's ACPI feature is enabled. The two selections available are [Enabled] and [Disabled]. The [Enabled] selection is factory set and recommended for most users.

System Setup

■ IRQ-3 assigned to - IRQ-15 assigned to

Only after the "Resources Controlled By" setting is set to [Manual] can the following IRQ-3 assigned to - IRQ-15 assigned to settings be changed.

These settings are used for the [PCI/ISA PnP] and [Legacy ISA] items.

[PCI/ISA PnP] : Used for PCI or ISA's PnP Card

[Legacy ISA] : Used for ISA Cards that do not comply with PnP

	INITIAL SETTING		INITIAL SETTING
IRQ-3 assigned to	Legacy ISA	IRQ-10 assigned to	Legacy ISA
IRQ-4 assigned to	Legacy ISA	IRQ-11 assigned to	PCI/ISA PnP
IRQ-5 assigned to	PCI/ISA PnP	IRQ-12 assigned to	Legacy ISA
IRQ-7 assigned to	Legacy ISA	IRQ-14 assigned to	Legacy ISA
IRQ-9 assigned to	Legacy ISA	IRQ-15 assigned to	PCI/ISA PnP

■ DMA-0 assigned to - DMA-7 assigned to

Only after the "Resources Controlled By" setting is set to [Manual] can the following DMA-0 assigned to - DMA-7 assigned to settings be changed. These settings are used for the [PCI/ISA PnP] and [Legacy ISA] items.

[PCI/ISA PnP] : Used for PCI or ISA's PnP Card

[Legacy ISA] : Used for ISA Cards that do not comply with PnP

	INITIAL SETTING		INITIAL SETTING
DMA-0 assigned to	PCI/ISA PnP	DMA-5 assigned to	PCI/ISA PnP
DMA-1 assigned to	PCI/ISA PnP	DMA-6 assigned to	PCI/ISA PnP
DMA-3 assigned to	PCI/ISA PnP	DMA-7 assigned to	PCI/ISA PnP

■ CPU to PCI Write Buffer

Setting for the PCI Write Buffer. If [Disabled] is selected, it becomes the CPU's Read Cycle [Enable] or [Disable] toggle. The [Enabled] selection is factory set and recommended for most users.

■ PCI Dynamic Bursting

Setting for the PCI's Burst Transmission. The available settings are [Enable] and [Disable]. [Enabled] is factory set and recommended for most users.

■ PCI Master 0 WS Write

Sets the duration of the wait for the writing to the PCI Bus to "0".

[Enabled] and [Disabled] are available. The [Enabled] setting is factory set and recommended for most users.

■ PCI Delay Transaction

This feature enables or disables the Chip Set's PCI Delay Transaction Cycle's built in 32Bit Posted Buffer support. [Enabled] and [Disabled] are available. The [Enabled] setting is factory set and recommended for most users.

■ PCI Master Read Prefetch

Enables or disables the PCI Master Read Prefetch feature. [Enabled] and [Disabled] are available. The [Enabled] setting is factory set and recommended for most users.

■ **PCI #2 Access #1 Retry**

Enables or disables the PCI "2 Access #1 Retry feature. [Enabled] and [Disabled] are available. The [Disabled] setting is factory set and recommended for most users.

■ **PCI IRQ Activated by**

Designates the interrupt method used for the unit's PCI slots. [Level] or [Edge] can be used. [Level] is factory set and recommended for most users.

■ **Assign IRQ For USB**

Designates if the interrupt is allocated for USB equipment or not. [Enabled] and [Disabled] are available. The PL-B910/PL-B911 (PL-B910 Series) units should be set to [Enabled].

5. 2. 6 LOAD BIOS DEFAULTS

Selecting "LOAD BIOS DEFAULTS" calls up the menu used to enter the minimum level system settings. It is normally not used.

5. 2. 7 LOAD SETUP DEFAULTS

With a PL-B900, PL-B901 (PL-B900 Series) unit, selecting "Load Setup Default" will revert the unit to the original factory settings.

With a PL-B910, PL-B911 (PL-B910 Series) unit, after selecting "Load Setup Default", be sure to change the following settings to revert the unit to the original factory settings.

- CHIPSET FEATURES SETUP Change [On Chip USB] to [Enabled].
Change [USB Keyboard Support] to [Enabled].
- PNP/PCI CONFIGURATION Change [Assign IRQ for USB] to [Enabled].
- INTEGRATED PERIPHERALS Change [Onboard Serial Port 4] to [Disabled].
Change [IDE Primary Master UDMA] to [Disabled].
Change [IDE Primary Slave UDMA] to [Disabled].

5. 2. 8 SYSTEM MONITOR UTILITY

Selecting SYSTEM MONITOR UTILITY menu item displays the following screen.

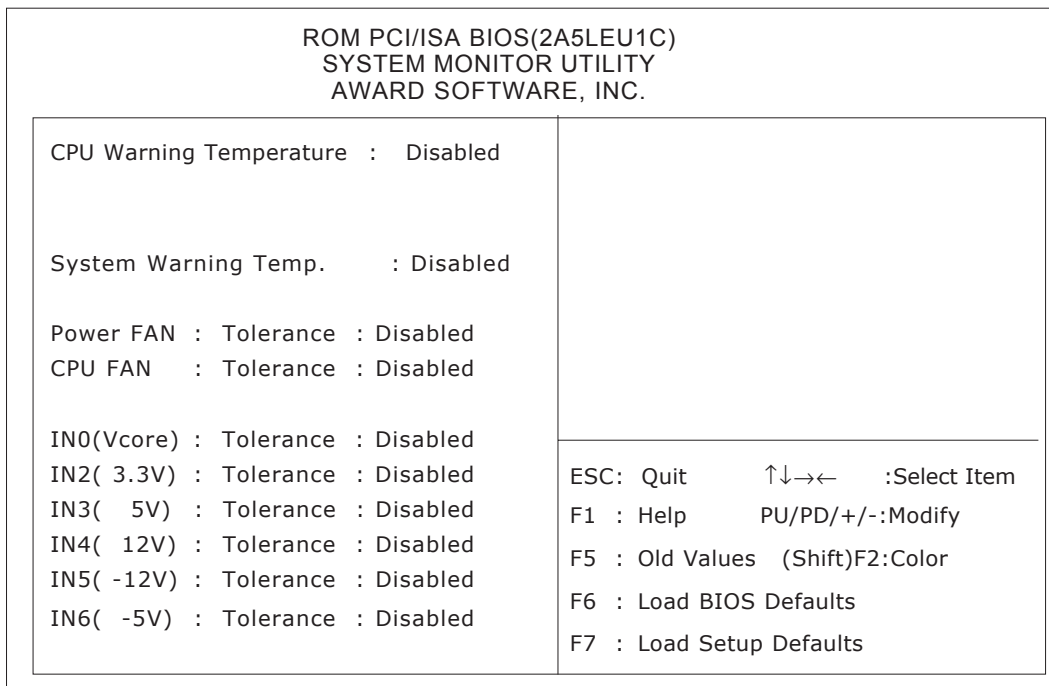

** The above settings are factory settings.*

System Setup

■ CPU Warning Temperature

Sets the temperature level that will trigger a CPU overheating alarm. Ten selections are available - [Disabled], [40°C/104°F], [45°C/113°F], [50°C/122°F], [55°C/131°F], [60°C/140°F], [65°C/149°F], [70°C/158°F], [75°C/167°F], [80°C/176°F]. The [Disabled] selection is factory set and recommended for most users.

■ System Warning Temp

Sets the temperature level where a motherboard overheating alarm is triggered. Ten selections are available - [Disabled], [40°C/104°F], [45°C/113°F], [50°C/122°F], [55°C/131°F], [60°C/140°F], [65°C/149°F], [70°C/158°F], [75°C/167°F], [80°C/176°F]. The [Disabled] selection is factory set and recommended for most users.

■ Power FAN

Sets the allowable range for the PL's power supply fan. [Disabled] , [+/-30%] and [+/-50%] are available. The [Disabled] selection is factory set and recommended for most users.

■ CPU FAN

Sets the allowable range for the PL's power supply fan. [Disabled] , [+/-30%] and [+/-50%] are available. The [Disabled] selection is factory set and recommended for most users.

■ INO(Vcore)

Sets the allowable range for the INO(Vcore) voltage. [Disabled], [+/-4%] and [+/-6%] are available. The [Disabled] selection is factory set and recommended for most users.

■ IN2(3.3V)

Sets the allowable range for the IN2(3.3V) voltage. [Disabled], [+/-4%] and [+/-6%] are available. The [Disabled] selection is factory set and recommended for most users.

■ IN3(5V)

Sets the allowable range for the IN3(5V) voltage. [Disabled], [+/-4%] and [+/-6%] are available. The [Disabled] selection is factory set and recommended for most users.

■ IN4(12V)

Sets the allowable range for the IN4(12V) voltage. [Disabled], [+/-4%] and [+/-6%] are available. The [Disabled] selection is factory set and recommended for most users.

■ IN5(-12V)

Sets the allowable range for the IN5(-12V) voltage. [Disabled], [+/-4%] and [+/-6%] are available. The [Disabled] selection is factory set and recommended for most users.

■ IN6(-5V)

Sets the allowable range for the IN6(-5V) voltage. [Disabled], [+/-4%] and [+/-6%] are available. The [Disabled] selection is factory set and recommended for most users.

5. 2. 9 INTEGRATED PERIPHERALS

Selecting INTEGRATED PERIPHERALS SETUP menu item displays the following screen.

ROM PCI/ISA BIOS(2A5LEU1C) INTEGRATED PERIPHERALS AWARD SOFTWARE, INC.			
OnChip IDE First Channel	:Enabled	Onboard Serial Port 3	: 3E8H
IDE Prefetch Mode	:Disabled	Serial Port 3 Use IRQ	: IRQ9
IDE HDD Block Mode	:Disabled	Onboard Serial Port 4	: 2E8H
IDE Primary Master PIO	:Auto	Serial Port 4 Use IRQ	: IRQ10
IDE Primary Slave PIO	:Auto		
IDE Primary Master UDMA	:Auto		
IDE Primary Slave UDMA	:Auto		
Onboard FDC Controller	:Enabled	ESC: Quit	↑↓→← :Select Item
Onboard Serial Port 1	:3F8/IRQ4	F1 : Help	PU/PD/+/-:Modify
Onboard Serial Port 2	:2F8/IRQ3	F5 : Old Values	(Shift)F2:Color
UR2 Mode	:Standard	F6 : Load BIOS Defaults	
Onboard Parallel Port	:3BC/IRQ7	F7 : Load Setup Defaults	
Parallel Port Mode	:SPP		

** The above settings are factory settings.*

However, with a PL-B910/PL-B911 (PL-B910 series) unit, change the [Onboard Serial Port 4] setting to [Disabled], change the [IDE Primary Master UDMA] to [Disabled], and change the [IDE Primary Slave UDMA] to [Disabled]

■ OnChip IDE First Channel

Designates the internal IDE port's setting. The two selections available are [Disabled] and [Enabled]. The [Enabled] selection is factory set and recommended for most users.

■ IDE Prefetch Mode

Designates if the IDE drive's high speed access is performed by enabling the Prefetch Mode. The two selections available are [Disabled] and [Enabled]. The [Disabled] selection is factory set and recommended for most users.

■ IDE HDD Block Mode

Designates the Hard disk's Block Operation Mode. The two selections available are [Disabled] and [Enabled]. The [Disabled] selection is factory set and recommended for most users.

■ IDE Primary Master PIO

Designates the Master Drive's PIO (Programmed Input/Output Mode. Only after the "Internal PCI/IDE" has been set to [Primary] can these IDE Primary Master PIO settings be entered. The selections available are [Auto], [Mode0], [Mode1], [Mode2], [Mode3], and [Mode4]. When using the CD-ROM unit, set this to "Mode 2".

System Setup

■ IDE Primary Slave PIO

Designates the Slave Drive's Operation Mode. Only after the "Internal PCI/IDE" has been set to [Primary] can these IDE Primary Slave PIO settings be entered. The selections available are [Auto], [Mode0], [Mode1], [Mode2], [Mode3], and [Mode4]. When using the CD-ROM unit, set this to "Mode 2".

■ IDE Primary Master UDMA

Designates the Master Drive's UDMA Operation Mode. The two selections available are [Auto] or [Disabled]. The [Auto] selection is factory set and recommended for most users. When using the CD-ROM unit, or a PL-B910/PLB911 (PL-B910 Series) unit, set this to [Disabled].

■ IDE Primary Slave UDMA

Designates the Slave Drive's UDMA Operation Mode. The two selections available are [Auto] or [Disabled]. The [Auto] selection is factory set and recommended for most users. When using the CD-ROM unit, or a PL-B910/PLB911 (PL-B910 Series) unit, set this to [Disabled].

■ Onboard FDC Controller

Designates whether the PL's FDD(Floppy Disk Drive) controller is used or not. The two selections available are [Disabled] or [Enabled]. The [Enabled] selection is factory set and recommended for most users.

■ Onboard Serial Port1

Designates the PL's Serial Port1 address setting. The selections include [Disabled], [Auto], [3F8/IRQ4], [2F8/IRQ3], [3E8/IRQ4] or [2E8/IRQ3]. The [3F8/IRQ4] selection is factory set and recommended for most users.

■ Onboard Serial Port2

Designates the PL's Serial Port2 address setting. The selections include [Disabled], [Auto], [3F8/IRQ4], [2F8/IRQ3], [3E8/IRQ4] or [2E8/IRQ3]. The [2F8/IRQ3] selection is factory set and recommended for most users.

■ UR2 Mode

Designates the IR function used by the PL's onboard I/O chip. The selections include [Standard], [Sharp IR], [IrDA SIR]. The [Standard] selection is factory set and recommended for most users. When serial port 2 is used for RS-232C communication, and the [standard] option's PL-IR100 selection is used, set this item to [IrDA/SIR].

■ Onboard Parallel Port

Selects the PL Parallel Port 1's I/O Address. The selections include [Disabled], [3BC/IRQ7], [378/IRQ7] or [278/IRQ5]. The [3BC/IRQ7] selection is factory set and recommended for most users.

■ Parallel Port Mode

Here, the parallel port's operation mode can be selected ([SPP], [EPP1.7], [EPP1.9], [ECP], or [ECP + EPP]). Normally, [SPP] is used and recommended for most users. When either [ECP] or [ECP+EPP] is selected, the [ECP Mode Use DMA] setting can be used.

■ ECP Mode Use DMA

Designates the ECP mode's DMA channel. [1] and [3] are available selections, however, this item can be set only when the Parallel Port Mode is set to either [ECP] or [ECP+EPP].

■ Onboard Serial Port 3

Designates the PL's Serial port 3 address setting. The selections include [Disabled], [3F8H], [2F8H], [3E8H], or [2E8H]. The [3E8H] selection is factory set and recommended for most users.

■ Serial Port 3 Use IRQ

Designates the PL's Serial Port 4 allocation numbers. The selections include [IRQ3], [IRQ4], [IRQ9], [IRQ10], or [IRQ15].

■ Onboard Serial Port 4

Designates the PL's Serial Port 4, which is internally connected to the touch panel, address setting. The selections include [Disabled], [3F8H], [2F8H], [3E8H], or [2E8H]. The [2E8H] selection is factory set and recommended for most users.

■ Serial Port 4 Use IRQ

Designates the PL's Serial Port 4 allocation numbers. The selections include [IRQ3], [IRQ4], [IRQ9], [IRQ10], or [IRQ15]. The [IRQ10] selection is factory set and recommended for most users.

5. 2. 10 IDE HDD AUTO DETECTION

Selecting the IDE HDD AUTO DETECTION menu item produces the following screen.

Provides automatic detection of any hard disk connected to the IDE. Normally unused.

```
ROM PCI/ISA BIOS(2A5IIU1C)
CMOS SETUP UTILITY
AWARD SOFTWARE, INC.

CYLS. HEADS PRECOMP LANDZONE SECTORS MODE
Drive C : ( Mb)

Select Drive C Option(N=Skip) : N
OPTIONS SIZE CYLS. HEADS PRECOMP LANDZONE SECTORS MODE
-----
2(Y) 2167 525 128 0 4199 63 LBA
1 2167 4200 16 65535 4199 63 NORMAL
3 2167 525 128 65535 4199 63 LARGE

Note : Some OSes (like SCO-UNIX) must use "NORMAL" for Installation

ESC:Skip
```

** The above settings are factory settings.*

Memo

Chapter

6 OS Setup

This chapter provides information about the set up of the PL's Windows® 95, Windows® 98 Second Edition, or Windows® NT operating systems (OS).

6.1 Setting Up Your PL OS

The Digital Electronics Corporation has prepared the following additional program files which are not supported by the standard versions of the Windows® 95, Windows® 98 Second Edition and Windows NT®4.0 operating systems. These files must be installed from the additional “PL-X900 Series Driver & Utility Disk” and the “USB Touch Panel Control Utility Disk”.

To set up the OS with these files, you will need to prepare one of the FDD units, the PL-FD200 or the PL-FD210 (only for the PL-B910/PL-B900), and a PS/2 compatible keyboard.

The software contained in the PL's accompanying “PL-X900 Series Driver & Utility Disk” and the “USB Touch Panel Control Utility Disk” is designed specifically for use with only the Windows type of OS. If this software is used with other OS types, its performance cannot be guaranteed.

PL Model	OS Type	Utility Disk
PL-B900 Series units (PL-B900/PL-B901)	Windows® 95, Windows® NT	PL-X900 Series Driver and Utility Disk
PL-B910 Series units (PL-B910/PL-B911)	Windows® 98 Second Edition	PL-X900 Series Driver and Utility Disk
		USB Touch Panel Control Utility Disk



Note: Be sure to read the Driver and Utility Disk README documents prior to using the PL unit, since they contain the latest PL related information and manual updates.

The README file contains the following information.

Windows® 95 (README.95)

- I. Preface
- II. Cautions
- III. Software Configuration
- IV. Installation Method
- V. Software Installation

Windows® NT 4.0 (README.NT)

- I. Preface
- II. Cautions
- III. Software Configuration
- IV. Installation Method
- V. Software Installation
- VI. System Automatic Log-On Settings
- VII. Uninterrupted Power Supply

Windows® 98 Second Edition (README.98)

- I. Preface
- II. Cautions
- III. Software Configuration
- IV. Installation Method
- V. Software Installation

6.1.1 Touch Panel Device Driver Settings

When using Digital's Standard Display or the FP-570 display, the following touch panel drivers will be needed.

With Windows® 95: Digital Electronics Corporation's PL-ME000

With Windows® NT 4.0: Gunze Corporation's TT-WINNT



The PL-ME000 software is designed exclusively by Digital for the Windows® 95 OS. The Gunze corporation's TT-WINNT software's performance is still being evaluated by Digital for the Windows® NT 4.0 system.

When installing the Touch Panel's device driver, the following page's dialog boxes will be used. Enter the settings given here in these screens.

◆ **Hardware Controls(Serial)**

COM Port

When connecting the Standard display: COM 4

When connecting the FP-570: COM 1 or COM 2

Configuration

Address : 2E8

Irq : 10

Baud rate : 9600

Parity : None

Data Bits : 8

Stop Bits : 1

◆ **Button Modes**

Current Button Mode : Time/Tap

◆ **User Controls**

Miscellaneous Settings

Click time : One level slower than Fast

Double Click speed : Slow

Lift off time : Fast

Stabilization : Low

Touch Offset : Leave unselected

Sound : Select (check mark)

Button simulation : Left

◆ **Advanced Settings**

Miscellaneous

Swap X/Y : Leave unselected

Initialize : Leave unselected

Memo

Chapter

7 Maintenance and Inspection

7-1 Cleaning the Filter

7-2 Periodic Maintenance Points

7.1 Cleaning the Filter

Since excessive dirt and dust in the filter of the PL's cooling fan can potentially affect the performance of the unit, regular inspection and cleaning of the filter is strongly recommended.

■ PL-B900/PL-B910 Unit

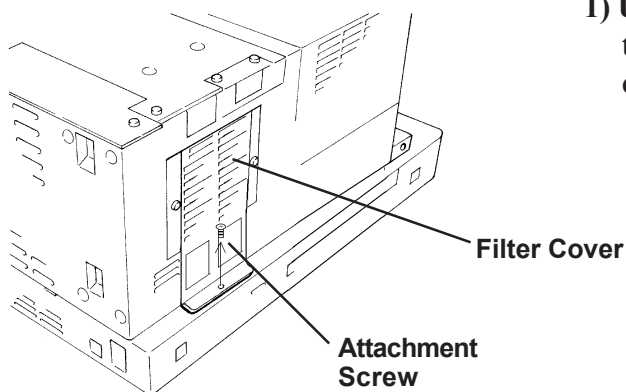

- 1) Unscrew the cooling fan filter cover's attachment screw and remove the filter cover.

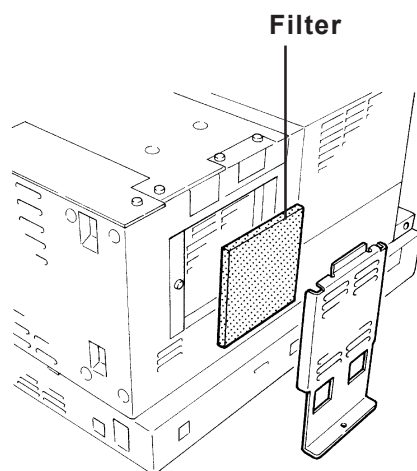

- 2) Remove the filter from the fan cover.

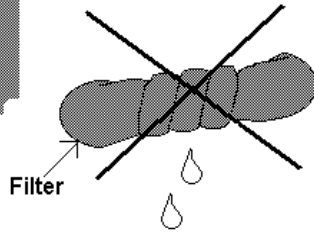
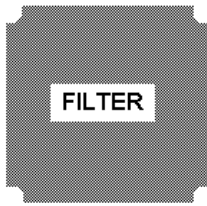

3) Clean the filter completely.

If stubborn dirt or stains are present, wash the filter with a neutral detergent.

- **Do not wring the filter to dry it.**
- **Be sure the filter is completely dry before reattaching the filter to the fan cover.**
- **Allow it to air dry. Do not leave the filter in direct sunlight.**

4) After reattaching the filter to the filter cover, reattach the cover to the cooling unit with the filter cover attachment screw.

■ PL-B901/PL-B911 Unit

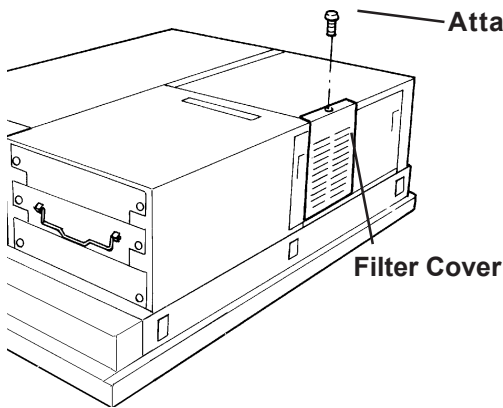

1) Unscrew the cooling fan filter cover's attachment screw and remove the filter cover.

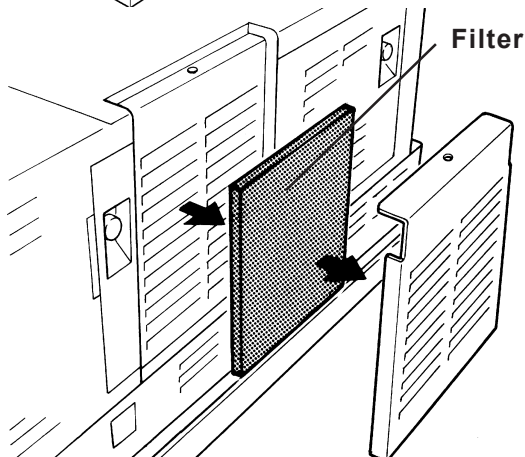

2) Remove the filter from the fan cover.

3) Clean the filter completely.

If stubborn dirt or stains are present, wash the filter with a neutral detergent.

- **Do not wring the filter to dry it.**
- **Be sure the filter is completely dry before reattaching the filter to the fan cover.**
- **Allow it to air dry. Do not leave the filter in direct sunlight.**

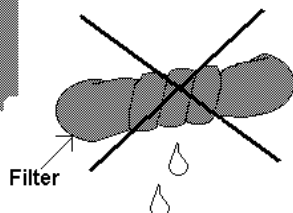
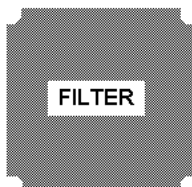

4) After reattaching the filter to the filter cover, reattach the cover to the cooling unit with the cover attachment screw.

7.2 Periodic Maintenance Points

Check the PL periodically to ensure it is in good working condition.

Ambient environment check

- Is the ambient temperature within the specified range?
(5°C to 50°C - with fan, 5°C to 40°C - without fan)
- Is the ambient humidity within the specified range (30%RH to 85 %RH) ?
- Is the atmosphere free of corrosive gas ?

Electrical specifications check

- Is the voltage adequate (AC85V to AC265V, 50/60 Hz) ?

Installation check points

- Is the connection cable firmly connected (not loose) ?
- Are any bolts or screws loose ?
- Are there any flaws or tears in the moisture resistant gesket ?

Display check

- Is the display bright enough ?



Note: When the PL's Standard Display's backlight needs to be replaced, please contact your local PL distributor.

Memo



A-1 Hardware Configuration

A-2 RAS Feature

A.1 Hardware Configuration

The following data explains the design of the I/O Map, Memory Map and Interrupt Map, as well as additional hardware design items including the RAS feature.

A.1.1 I/O Map

Address	AT System Device	System Device
0000H - 001FH	DMA controller (8237)	
0020H - 003FH	Interrupt controller (8259A)	
0040H - 005FH	System timer (8254)	
0060H - 006FH	Keyboard Controller	
0070H - 007FH	Real-time clock, NMI mask	
0080H - 009FH	DMA page register	
00A0H - 00BFH	Interrupt controller 2 (8259A)	
00C0H - 00DFH	DMA controller 2 (8237)	
00F0H - 00FFH	Numeric data processor	
01F0H - 01FFH	Hard disk (IDE)	
0200H - 0207H	Game I/O	
0290H - 0297H	Reserved	System Monitor
0298H - 029FH	Reserved	RAS
02E8H - 02EFH	Reserved	Touch Panel Serial Port 4 (COM4) (for Standard monitor)
02F8H - 02FFH	Serial port 2 (COM2) : General Use	
03B0H - 03BBH	Video controller (VGA)	
03BCH - 03BFH	Parallel port 1 (LPT1)	
03C0H - 03DFH	Video controller (VGA)	
03E8H - 03EFH	Reserved	Serial port 3 (COM3)
03F0H - 03F7H	Floppy disk controller	
03F8H - 03FFH	Serial port 1 (COM1) :General Use	

A.1.2 Memory Map

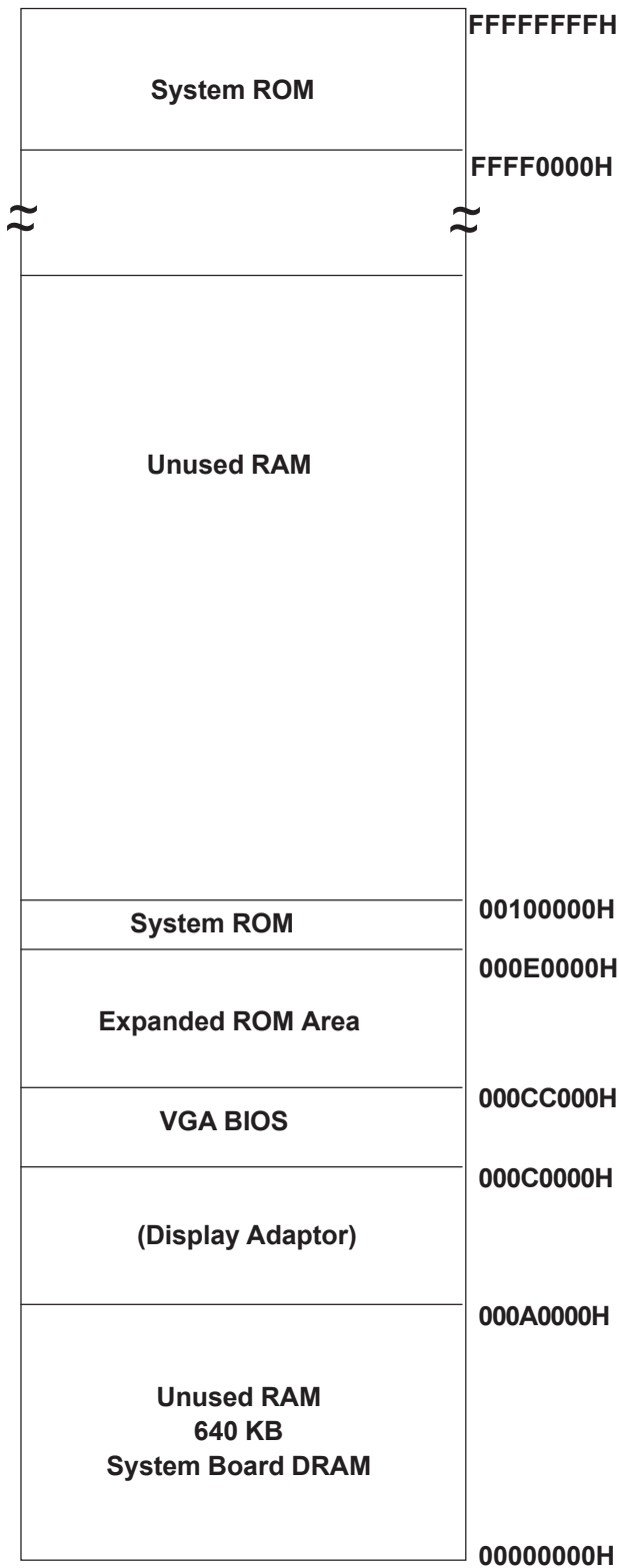

A.1.3 Interrupt Map

■ Hardware Interrupt List

	Description
NMI 0	Parity Error or I/O Channel Check
IRQ 0	Timer (in the Chipset)
IRQ 1	Keyboard
IRQ 2	Cascade from Controller 2
IRQ 3	Serial Port 2 (COM2): General Use Port
IRQ 4	Serial Port 1 (COM2): General Use Port
IRQ 5	Available for users
IRQ 6	Floppy Disk Controller
IRQ 7	Parallel Port 1 (LPT 1) : Printer Port
IRQ 8	Real Time Clock
IRQ 9	Serial Port 3 (COM3): General Use Port
IRQ 10	Serial Port 4 (COM4): Touch Panel (for Standard monitor)
IRQ 11	Available for users
IRQ 12	PS/2 Mouse
IRQ 13	Numeric Data Processor
IRQ 14	Hard Disk (IDE)
IRQ 15	PL-B900/PL-B901: Available for User PL-B910/PL-B911: Used by USB

■ DMA Channel List

	Description	
DMA 0		For 8-bit transmission
DMA 1		
DMA 2	Floppy disk controller	
DMA 3		
DMA 4	Cascade to controller 1	For 16-bit transmission
DMA 5		
DMA 6		
DMA 7		

A.2 RAS Feature

A.2.1 PL's RAS Features

RAS, which stands for Reliability, Availability and Serviceability, is a device-level monitoring function that provides a variety of features to improve the reliability of your PL system.

Though the standard set of RAS features used will vary depending on the devices used, the following features are used to provide Alarm Monitoring and External Input Signal support.

Alarm Monitoring	Power Voltage Alarm Cooling Fan Alarm Internal Temperature Alarm Watchdog Timer Time Up Mirror Disk Alarm
External Input Signal	Standard Signal Input (DIN 2 bit) Remote Reset Input

Also, when either the one of the above mentioned alarms occurs, or an external signal input is received, the following types of alarm processing output signals and features are supported.

External Output Signal	Standard Signal Output (DOUT 1 bit) Alarm Output (1 point) Lamp Output (1 point)
Types of Processing (all units)	LED Indicator (3-state display – 1 point) Pop-up Message Output Buzzer Output System Shutdown

Furthermore, using the PL's System Monitor feature (included in the PL's software utility disk), allows the easy setting and control (Enable/Disable) of the aforementioned Alarm Monitor and External Input Signals.

Last, the system monitor feature's use of an Application Link Library (API-DLL) allows it to also be used with other applications.

**1 When a Mirror Disk Alarm occurs and the standard RAS feature settings are used, the alarm output is limited to the Mirror Disk unit's LED indicator. (Alternately flashing orange and green)*

**2 The remote reset feature's input can be either enabled or disabled, the alarm output setting cannot be set to trigger a forced system reset.*

**3 For System Monitor Feature details, refer to the accompanying Driver and Utility disk.*

▼ Reference ▼ Chapter 6 - Setting up Your PL OS

A.2.2 RAS Feature Details

■ Alarm Monitoring

◆ Power Voltage Alarm

Monitors the condition of the PL's internal and CPU power.

◆ Cooling Fan Alarm

Monitors the condition of the PL's internal power and CPU cooling fans.

◆ Internal Temperature Alarm

Monitors the PL's internal and CPU vicinity temperatures.

The degree of monitoring (3 levels) and the enabling or disabling of the above three items is performed via the System Setup Area's settings.

For detailed information about the monitoring level settings,

Reference *5.2.6 SYSTEM MONITOR UTILITY*

This utility can also be used to enable or disable the above mentioned features, as well as designate what type of processing is to be performed.

◆ Watchdog Timer Time Up

This feature alternately writes Time Up Count values from the CPU to the RAS feature's special programmable timer and then periodically clears them, which provides a means of monitoring the CPU's performance. If the clearing of this count value is stopped, the timer will overflow and an alarm will be detected. The System Monitor utility can be used to enable or disable this feature, as well as designate what type of processing is to be performed.

◆ Mirror Disk Alarm

Whenever a disk crash, or other alarm event occurs to the optional Mirror Disk unit, this unit's LED indicator will flash (either orange or green) to indicate there is a problem.

This unit's error detection occurs independently of and cannot be set by the RAS feature.

■ External Input Signal

The PL's RAS interface connector uses the following input signals.

Standard Signal Input (DIN)

This standard digital input is used for alarm detection in external devices. The input signal uses two bits.

The System Monitor utility can be used to enable or disable this feature, as well as designate what type of processing is to be performed once a signal is received.

Remote Reset Input

This is the reset signal sent from an external device to the PL. When this signal is enabled, a forced reset of the PL is performed.

The System Monitor utility can be used to enable or disable this feature

External Input Signal (for both DIN and Remote Reset Input)

- External Power DC12V to DC24V connections are possible
- Input Protection Protection Diode
- Isolation Used (photo-isolation)

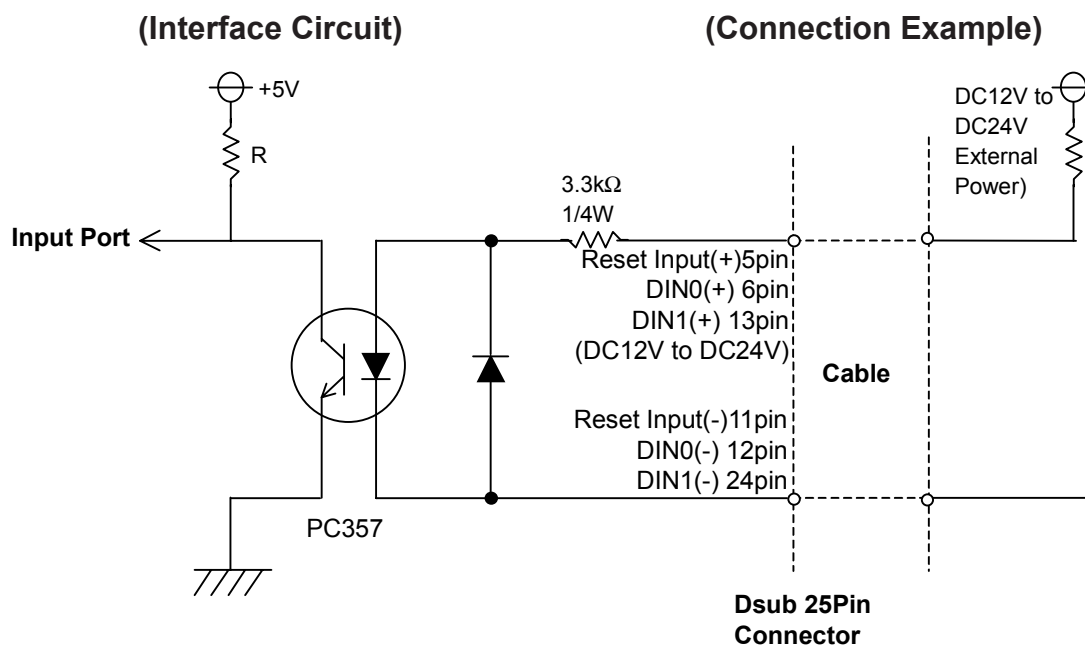

For connection pin location details,

Reference 2.3.5 RAS Interface

Appendices

External Output Signal

The PL's RAS interface connector uses the following output signals.

General Purpose Signal Output (DOOUT)

This general purpose digital output signal provides system condition information to external devices.

The System Monitor's API-DLL are used by applications to control this signal.

Alarm Output (1 point)

Lamp Output (1 point)

The above mentioned general purpose digital output signals provide system condition information to external devices.

The System Monitor utility can be used to enable or disable any of these output signals.

Also, when alarm output is enabled, the orange colored LED indicator will also blink.

External Output Signal (used for DOOUT, Alarm Output, Lamp Output)

- Output Specification DC24V 100mA (MAX)
- Isolation Used (photo-isolation)

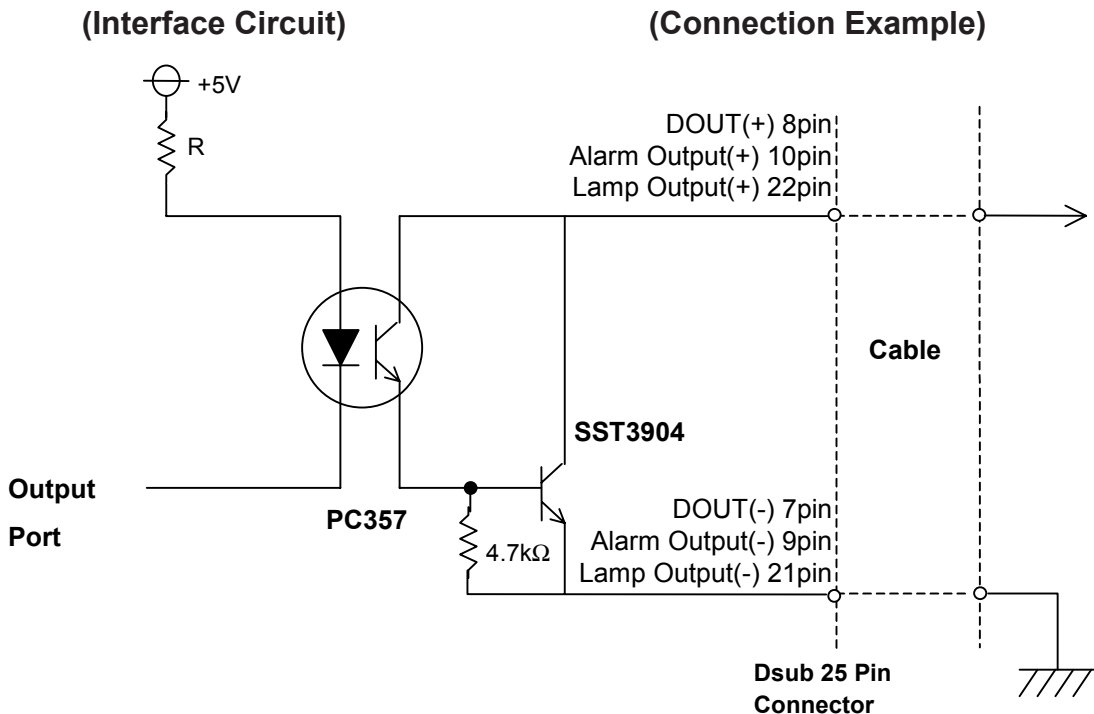

For connection pin location details,
Reference 2.3.5 RAS Interface

■ Types of Processing (all units)

The PL provides system condition information via the following methods.

LED Indicator (3-state display – 1 point)

In addition to indicating if the unit's power is ON or OFF, the 3-state LED indicator (power lamp) provides the following system condition information.

Color	System Condition	Output Created
Green	Normal Operation (Power ON)	None
Orange	RAS has detected a system alarm.	The alarm output set in the system monitor is enabled.
Flashing Orange/ Green	Mirror Disk Alarm has occurred	None

Pop-up Message Output

This feature uses the Windows® system's pop-up message feature to indicate that an alarm has occurred.

Buzzer Output

This feature uses the PL's internal speaker to indicate the system's condition.

System Shutdown

This feature shuts down the PL's OS (Windows® 95/ Windows® 98 Second Edition/ Windows® NT 4.0). The System Monitor utility can be used to enable or disable this feature.

A.2.3 RAS Feature Overview

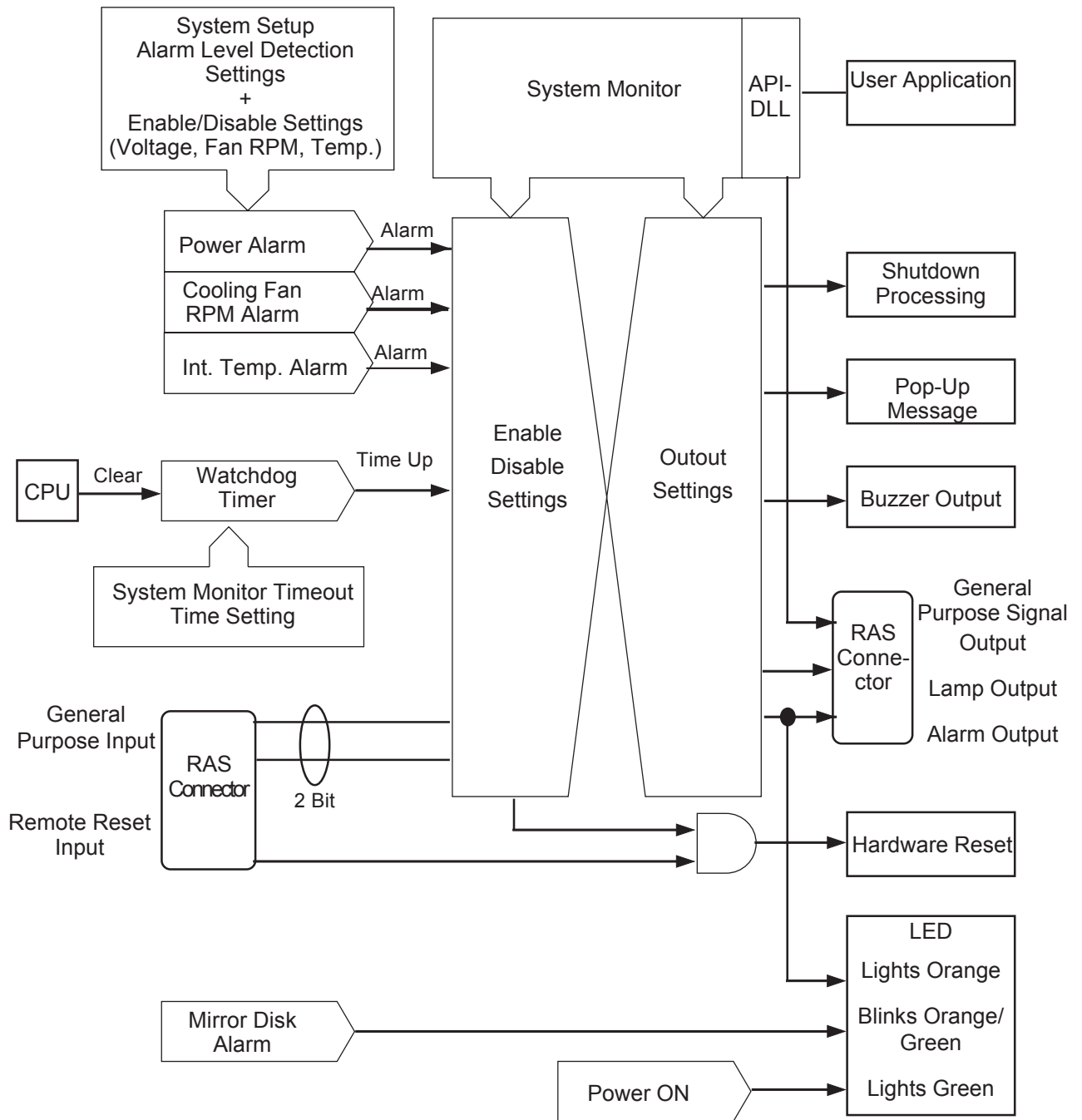

Memo