

PL-6700 Series
Panel Computer
User's Manual

Introduction

Digital's PL-6700 series (PL-6700T, PL-6700S) of Panel Computers are multi-purpose factory automation (FA) computers, which embody Digital's latest, cost-effective architecture.

Before using the PL, read this manual thoroughly to familiarize yourself with the PL's operation procedures and functions.

NOTE:

1. It is forbidden to copy the contents of this manual in whole, or in part, without the permission of the Digital Electronics Corporation.
2. The information in this manual is subject to change without notice.
3. This manual was written with care; however, if you should find any error or omissions, please contact Digital Electronics and inform them of your findings.
4. Please be aware that we are not responsible for any damages resulting from the use of our products, regardless of article 3 above.
5. Specifications set out in this manual are for overseas products only, and, as a result, some differences may exist between the specifications given here and the Japanese ones.

Product names used in this manual are the trademarks of their respective manufacturers.

© Copyright 1998, Digital Electronics Corporation

MS-DOS® and Windows®95 are registered trademarks of the Microsoft Corporation.

IBM® DOS® are registered trademarks of IBM.

Safe Product Usage

This manual contains a variety of safety markings to help you safely and correctly operate Digital's PL-6700 series of Panel Computers, which includes the PL-6700T and PL-6700S, each of which are hereafter referred to collectively as the "PL." Be sure to keep this manual handy for future reference.

■ Safety Icons

This manual uses the two icons below to call attention to information important for the safe and correct use of the PL. Please pay attention to these icons and follow all instructions given by them.

The safety icons and their meanings are:



Indicates a potentially hazardous situation which could result in serious injury or even death, if the instructions are not followed.



Indicates a potentially hazardous situation which could result in minor injury or equipment damage if the instructions are not followed.



Essential Safety Precautions

Be sure to follow the instructions given below to ensure the safe use of the PL.

- To avoid a possibility of electrical shock, be sure to connect the power cord to the PL before connecting it to the main power supply.
- A fire or electrical shock may result if voltages are used with the PL that are beyond the specified range. Be sure to only use the specified voltage.
- Before opening the PL's protective cover, be sure to turn the unit's power OFF. This is because the PL's internal parts carry high voltages.
- To avoid fires or electrical hazards, do not modify the product in any way.
- Do not create touch panel switches that are used to either control or to ensure the safety of equipment and personnel. Mechanical switches, such as an emergency stop switch, a deadman (two-handed) start switch, etc., must be installed and operated via a separate control system.
- If metal particles, water or other types of liquids contact any of the PL's internal parts, immediately turn the unit's power OFF, unplug the power cord, and contact either your dealer or Digital Electronics Corporation.
- Read and understand Chapter 4 "Installation and Wiring" thoroughly in order to select an appropriate installation location for the PL.
- Before either plugging in or unplugging a board or interface connector, be sure to turn the PL's power OFF.
- To prevent a possible explosion, do not install the PL in areas containing flammable gases.
- The PL is not appropriate for use with aircraft control devices, aerospace equipment, central trunk data transmission (communication) devices, nuclear power control devices, or medical life support equipment, due to these devices' inherent requirements of extremely high levels of safety and reliability.
- When using the PL with transportation vehicles (trains, cars and ships), disaster and crime prevention devices, various types of safety equipment, non-life support related medical devices, etc. redundant and/or failsafe system designs should be used to ensure the proper degree of reliability and safety.



General Safety Precautions

Follow the instructions given below for correct and safe use of the PL.

- Do not push on the PL's screen too strongly, with either your finger or with a hard object. Excessive pressure can scratch, crack or damage the screen.
- If the screen becomes dirty or smudged, moisten a soft cloth with diluted neutral detergent, wring the cloth well, and wipe the display. Do not use thinner or organic solvents.
- Do not use a pointed object, such as a mechanical pencil or screwdriver, to press any of the touch panel's switches, since they can damage the display.
- Avoid exposing and operating the PL in direct sunlight, high temperatures and humidity, and in areas where excessive dust and vibration will occur.
- Avoid using the PL in areas where sudden, extreme changes in temperature can occur. This may cause condensation to form inside the unit, possibly leading to an accident.
- To prevent the PL from overheating, be sure its air circulation vents are clear and clean, and keep the unit's operation area well-ventilated.
- Avoid operating or storing the PL near chemicals, or where chemicals can come into contact with the unit.
- Since the PL-6700's hard disk drive (HDD) is a consumable item, i.e. it has a definite usage lifetime, be sure to back up its data frequently and perform regular maintenance.
- To prevent file damage, be sure to shut down your PL's OS before turning the PL OFF.

Notes on Handling the LCD

- The PL's LCD contains a strong irritant. If the panel is ever cracked and the LCD's liquid contacts your skin, be sure to wash it with running water for at least 15 minutes. If any of this liquid should enter your eye, be sure to flush your eye with running water for more than 15 minutes, and see a doctor immediately.
- The current brightness of the LCD screen will depend on the screen's current display and the LCD's contrast adjustment. Any brightness variations that result are normal for LCD displays.
- There are minute grid-points (Dark or light points) on the LCD surface. These points are not defects and are a part of the PL panel's design.
- Occasionally crosstalk (shadows appearing on extended display lines) will appear on the display. This phenomenon is a common attribute of LCDs and is not a defect.
- The displayed color will look different when viewed from an angle outside the specified view angle. This is also normal.

- Displaying a single screen image for long periods of time can cause an afterimage to remain on the screen. To correct this, turn the unit OFF for 5 to 10 minutes, then ON again. This phenomenon is a common attribute of the LCDs, and is not a defect. To prevent this effect, you can:

- use the Display OFF feature; if the same image is to be displayed for a long period of time.
- change the screen display periodically to prevent the displaying of a single image for a long period of time.

For further information about the PL's LCD panel, please contact your local PL distributor.



- **The Digital Electronics Corporation cannot be held responsible or provide any compensation for damage(s) caused by the loss of data stored in the PL-6700's hard disk drive (HDD). It is therefore strongly suggested that all important data and software be backed up regularly to an external data backup device.**
- **Please be aware that the Digital Electronics Corporation bears no responsibility for any damages resulting from the customer's application of this unit's hardware or software.**
- **Please be aware that the Digital Electronics Corporation will not provide compensation for any damages occurring as a result of problems with this unit's software or hardware.**

Notes on UL Application

The PL6700-T4* and the PL-6700-S4* are (c)UL 1950 recognized products. (UL File No. E177793). Please pay special attention to the following instructions when applying for UL approval for machinery which includes one of these PL units built in. Machinery with a PL mounted in it requires UL inspection for the combination of the PL and the machinery.

- PL conforms as a component to the following standards:
 - UL 1950, Third Edition, dated July 26, 1995 (Standard for Safety of Information Technology Equipment, including Electrical Business Equipment)
 - CSA-C22.2 No. 950-M93 (Standard for Safety of Information Technology Equipment, including Electrical Business Equipment)
 - PL6700-T4* (UL Registration Model No.: 0880044-1)
 - PL6700-S4* (UL Registration Model No.: 0880044-2)
- If the PL is installed so as to cool itself naturally, be sure to install the PL in a vertical position. Also, be sure that the PL is installed so that it is at least 50mm away from any adjacent structures or devices. If these requirements are not met, the heat generated by the PL's internal components may cause the unit to fail to meet UL standard requirements.

Notes on CE Marking

The PL6700-T4* and the PL6700-S4* are CE marked, EMC compliant products.

<Complies with the following EC Directives>

89/336/EEC, 92/31/EEC, 93/68/EEC, 73/23/EEC

<Complies with the following Standards>

■ **Safety**

IEC950 (A3:1995), EN60950 (A3:1995)

■ **EMI (EN50081-2)**

EN55022 (Class A) (1994), EN61000-3-2 (1995), EN61000-3-3 (1995)

■ **EMS (EN50082-2)**

EN61000-4-2 (1995), EN61000-4-4 (1995), EN61000-4-5 (1995), EN61000-4-8 (1993), EN61000-4-11 (1994), ENV50140 (1993), ENV50141 (1993), ENV50204 (1995)

What is IP65f?

This unit's protection rating of IP65f is actually a composite code, consisting of the internationally recognized British "Ingress Protection" standard (BS EN 60529:1992) - "IP65", and the standard developed by the Japanese Electronics Manufacturer's Association (JEM) - "f". This code is used in this manual to identify a given product's degree of structural resistance to a variety of environmental elements and thus, prevent problems or accidents related to the inappropriate use of a product.

The individual meaning of each character of this code is explained below. This code indicates the degree of ingress protection provided from the front face of the PL, and assumes that the PL is securely mounted into a metal panel.

IP	6	5	f
(1)	(2)	(3)	(4)

(1) Designates the type of protection provided.

(2) Indicates the degree of protection provided to the human body by the unit, and the degree of protection provided by the unit's front face from particles/dust intrusion into the interior of the unit.

Here, "6" indicates that the unit is completely protected from dust intrusion.

(3) Indicates the degree of protection provided by the unit's front face from water intrusion into the interior of the unit.

Here, "5" indicates that the unit is protected from water intrusion from a direct water jet.

(4) Indicates the degree of protection provided by the unit's front face from oil particle intrusion into the interior of the unit.

Here, "f" indicates that the unit is completely protected from oil intrusion via either oil particles or oil splashes from any direction (to the front panel).



For information about the PL's protective structure, refer to page 2-3.

Table of Contents

Preface

Introduction i
Safe Product Usage ii
Essential Safety Precautions iii
General Safety Precautions iv
What is IP65f? vii
Table of Contents viii
Prior to Using the PL xi
New PL-6700 Features xii
Unpacking the PL xiii
Information Symbols xiv

Chapter 1 Overview

1-1 System Configuration 1-1
1-2 Options 1-2
1-3 PL Series Panel Types 1-3

Chapter 2 Specifications

2-1 General Specifications 2-1
 2-1-1 Electrical Specifications 2-1
 2-1-2 Environment Specifications 2-1
 2-1-3 Dimensions 2-1
2-2 Performance Specifications 2-2
 2-2-1 Performance Specifications 2-2
 2-2-2 Display Functions 2-2
 2-2-3 Expansion Slots 2-3
2-3 Interface Specifications 2-4
 2-3-1 Printer Interface 2-4
 2-3-2 Keyboard Interface 2-4
 2-3-3 Mouse Interface 2-5
 2-3-4 RS-232C Interface (COM1/COM2/COM3) 2-5
 2-3-5 CRT Interface (VIDEO) 2-5
 2-3-6 Contrast Adjustment (PL-6700S only) 2-6
2-4 PL External Features 2-7
2-5 PL Dimensions 2-9
 2-5-1 PL-6700T/PL-6700S General Dimensions 2-9
 2-5-2 Installing the Full Size Cover 2-11
 2-5-2 Installation Slot Dimensions 2-12

Chapter 3 Installing Optional Units and Expansion Boards

3-1 Available Options and Expansion Boards	3-1
3-2 Installing Options and Expansion Boards	3-3
3-2-1 Attaching the PL's Support Leg	3-3
3-2-2 Installing the DIM Module (PL-EM200)	3-4
3-2-3 Removing or Installing the FDD Unit (PL-FD100)	3-6
3-2-4 Removing or Installing the HDD unit (PL-HD100)	3-7
3-2-5 Installing an Expansion Board	3-9
3-2-6 Installing the IDE Slave Adapter (PL-SA100)	3-11

Chapter 4 Installation and Wiring

4-1 Installation Cautions	4-1
4-2 Installing the PL	4-3
4-2-1 Installation Procedures	4-3
4-3 Wiring the PL	4-6
4-3-1 Connecting the Power Cord	4-6
4-3-2 Power Supply Cautions	4-8
4-3-3 Grounding Cautions	4-9
4-3-4 Cautions When Connecting I/O Signal Lines	4-9

Chapter 5 System Setup

5-1 Setup Procedures	5-1
5-2 System Parameters	5-2
5-2-1 STANDARD CMOS SETUP	5-2
5-2-2 BIOS FEATURES SETUP	5-4
5-2-3 CHIPSET FEATURES SETUP	5-6
5-2-4 POWER MANAGEMENT SETUP	5-7
5-2-5 PNP/PCI CONFIGURATION SETUP	5-9
5-2-6 INTEGRATED PERIPHERALS SETUP	5-11
5-2-7 IDE HDD AUTO DETECTION SETUP	5-13
5-2-8 HDD LOW LEVEL FORMAT SETUP	5-14

Chapter 6 Bundled Software

6-1 PL-6700 Floppy Disk File List	6-1
--	------------

Chapter 7 Maintenance and Inspection

7-1 Cleaning the Display 7-1
7-2 Filter Cleaning..... 7-2
7-3 Periodic Maintenance Check Points 7-3

Appendices

1 Hardware Configuration A-1
 1-1 I/O Mapping A-1
 1-2 Memory Mapping A-3
 1-3 IRQ Mapping A-4
2 Serial Communications A-5
3 Printer Cable Connections A-6
4 BIOS Lists..... A-15

Index

Prior To Using the PL

Prior to actual use, be sure to setup your PL as follows.

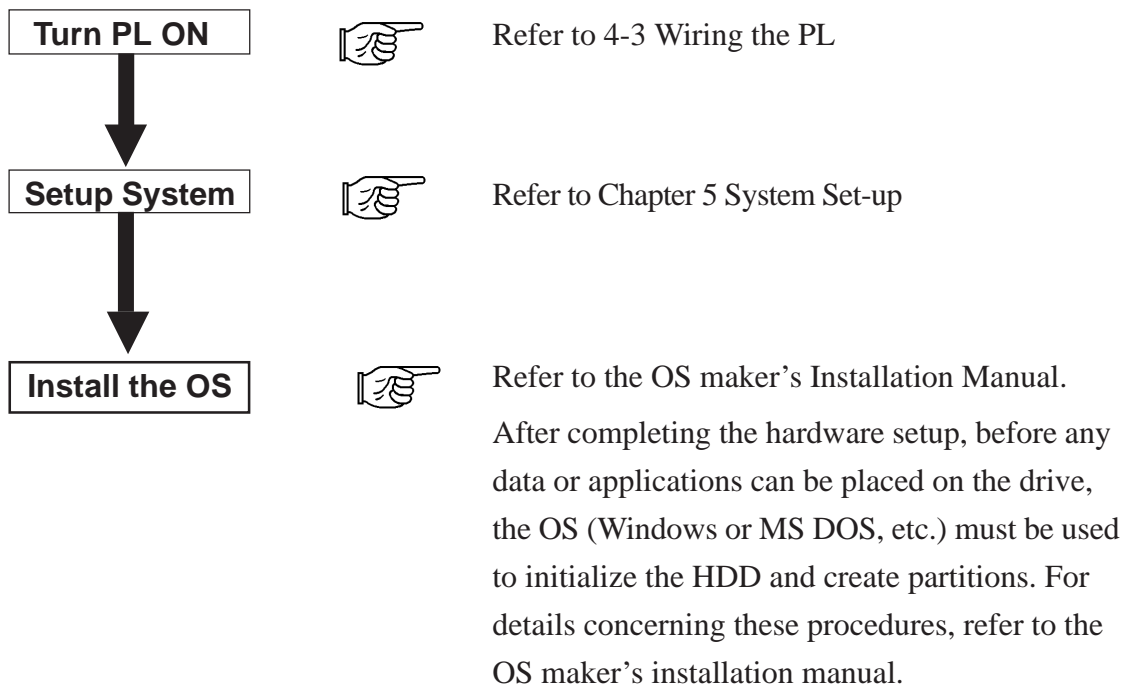

- For system setup and OS installation, a PS/2 type keyboard is necessary.
- When using Windows® NT4.0/Windows® 95, be sure to install the PL-6700 Driver & Utility Disk's Display Driver (For installation procedures, see the disk's README.TXT file).
 - For information on the PL-6700's bundled utility software, see the README.TXT file on the Driver & Utility Disk.
- Since the PL-6700's hard disk drive (HDD) is a consumable item, i.e. it has a definite usage lifetime, be sure to back up its data frequently and perform regular maintenance.

New PL-6700 Features

The PL-6700 series displays are equipped with the following features:

■ The Latest, High-Performance Architecture

Designed around the Pentium® 133 MHz CPU, the PL utilizes the type of high performance architecture that offers you superior compatibility. Add to this unrivalled support of the Windows 95®/NT® and other operating systems.

■ Bright 12.1" LCD with a Wide Viewing Angle

The PL's large 12.1-inch 800 x 600 dot LCD display is available with TFT or STN color, each offering excellent visibility and brightness.



- Digital's top of the line TFT color LCD model allows you to create detailed and powerful visual images, with excellent brightness, a wide viewing angle, and a display capable of 260,000 colors.
- In addition to their superior cost performance, Digital's STN type LCDs provide a high quality color display that rivals our TFT, at a reasonable price.

■ Easy Front Panel Installation

The PL is designed to be installed easily into the front of any panel or device. It is also rugged enough for use in harsh, industrial environments, such as those found in the factory automation industries and boasts an IP65f rating.

■ High Resolution, Analog-Resistance-Film Touch Panel

Standard equipment with the PL is a high resolution 1024 × 1024 touch panel. Also, the Windows® 95 mouse emulation utility provides mouse-like functionality and pointer control.

■ Highly Expandable

For the easy enhancement of your PL unit, 4 ISA-bus expansion slots are provided. (2 PCI slots are also available) These slots can accommodate both Digital's own optional boards as well as other commercially available expansion boards.

Digital also offers a wide variety of optional products, such as an -5/-12V DC power unit, DIM memory modules, etc. to name just a few.

Unpacking the PL

The PL package should include the following items:

PL-6700 Unit

(PL-6700T, PL-6700S)

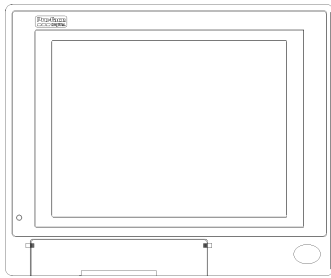

Be careful when installing the PL -6700 to not damage the built-in HDD

Power Cord

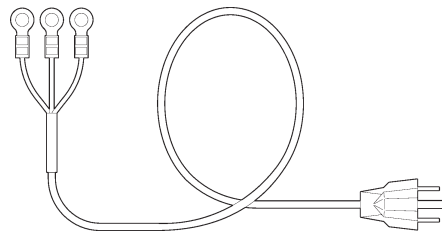

This cord is designed only for 100V use. Any other voltage will require a different cable.

PL6700 Floppy Disks (2)



Installation Brackets (8)



Panel Computer PL-6700 Series User's Manual (English)

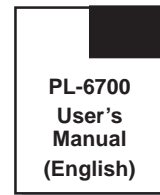

Angle Plate (1)



Panel Computer PL-6700 Series User's Manual (Japanese)

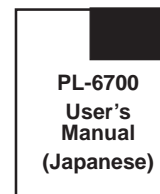

Information Symbols

This manual uses the following icons:



Indicates a warning or a product limitation. Be sure to follow the instructions given with this icon to insure the safe operation of the PL.



Contains additional or useful information.



Indicates terms or items that require further explanation. See the footnote on that page.



Indicates pages containing related information.



Indicates steps used to accomplish a given task. Be sure to follow these steps in the order they are written.

Chapter 1

Overview

- 1-1 System Configuration
- 1-2 Options
- 1-3 PL Series Panel Types

1-1 System Configuration

The following figure shows the peripheral devices that can be connected to the PL.

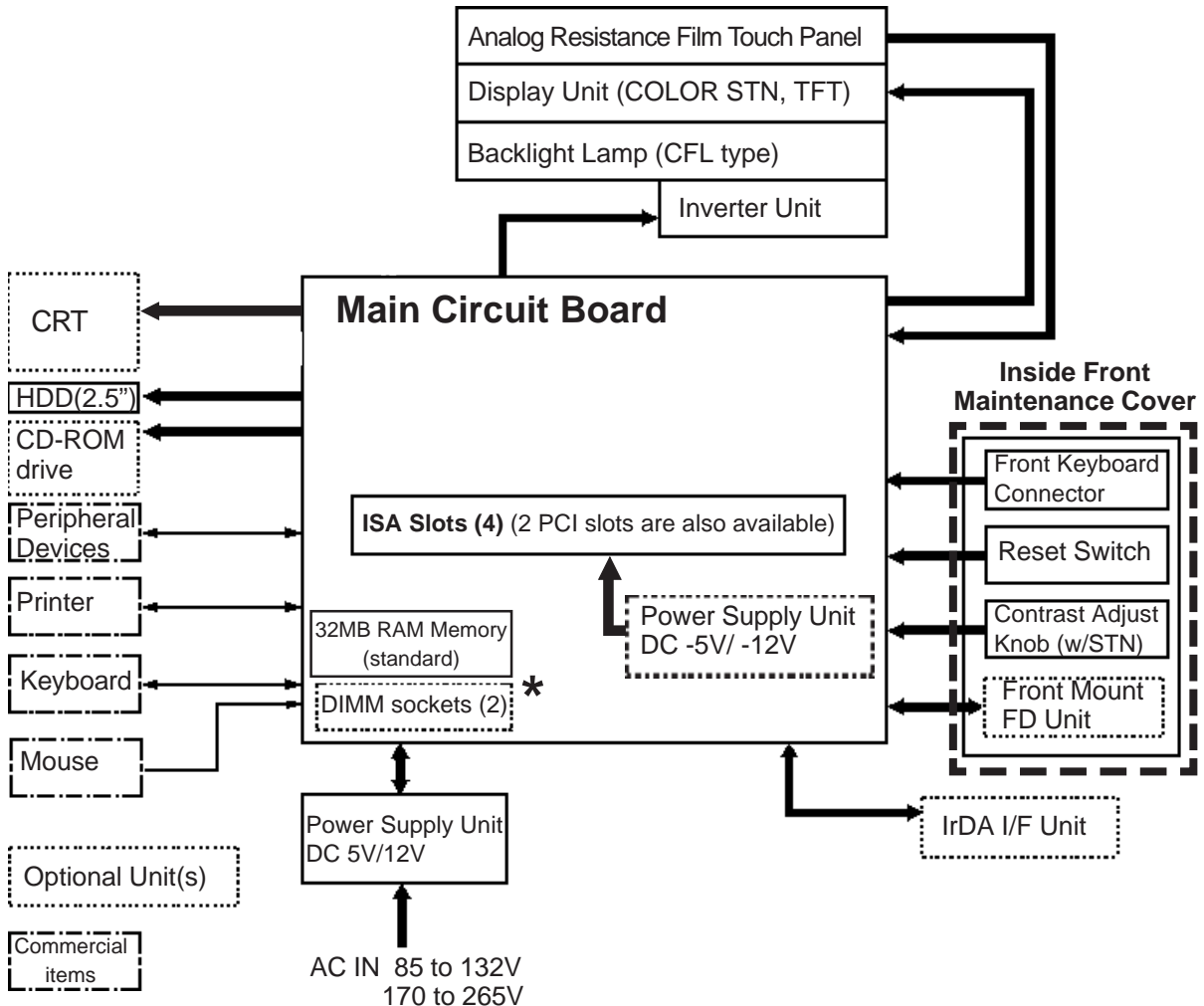

NOTE Boxes marked with a border represent optional items.
 Boxes marked with a border represent User supplied items.

CAUTION! The figure above shows simply the internal data flow and the PL's peripheral connections, and may differ from the actual layout used by the customer.

1-2	Options
------------	----------------

The following table provides a list of optional products for the PL.

Expansion Options

Name	Model number	Description
DIM Module	PL-EM200	Main Memory Board
FDD Unit	PL-FD100	PC/AT Compatible 3.5" FDD unit
IDE Slave Adapter	PL-SA100	Adapter used for attaching an IDE (ATAPI) compliant CD-ROM drive (DC power cord included)
IrDA Unit (under development)	PL-IR100	IrDA (Ver. 1.0) compatible infrared data transmission module.
-5V/-12V Power Unit	PL-PW100	Provides -5V and -12V power to expansion slots. Can provide a total of 200mA of current (sum of all four slots).
CD-ROM Drive Unit	PL-DK200	IDE (ATAPI) compliant CD-ROM drive unit (Connection cable is included in unit)

Accessories

Name	Model number	Description
Screen Protection Sheet	PL-CS100	Disposable overlay sheets for display face protection and stain resistance. Touch panel senses User's touch through sheet.

Maintenance Options

Name	Model number	Description
Mounting Brackets	GP070-AT00-MS	Used to install the PL into a panel or cabinet. Same as original equipment brackets.
Moisture Resistant Gasket	PL-WS100	Used to prevent moisture from entering into the PL's case from the front face. Same as original equipment gasket.
HDD Unit *1	PL-HD100	Built-in 2.5" HDD unit
Full Sized Cover	PL-FC100	Attached when ISA bus full-sized board is installed in expansion slot.

Software Options

Name	Model number	Description
TT-WIN/95 *2		Touch Panel mouse driver that provides mouse-like operability to the PL's touch panel. (for Windows 95 OS)
TT-WIN/NT *2		Touch Panel mouse driver that provides mouse-like operability to the PL's touch panel. (for Windows NT OS)

*1 Since the PL-6700's hard disk drive (HDD) is a consumable item, i.e. it has a definite usage lifetime, be sure to back up its data frequently and perform regular maintenance.

*2 Depending on the customer's OS, one of these drivers will be required to allow this type of touch operation. Please contact your local PL distributor for ordering details.

1-3 PL Series Panel Types

Model Number:

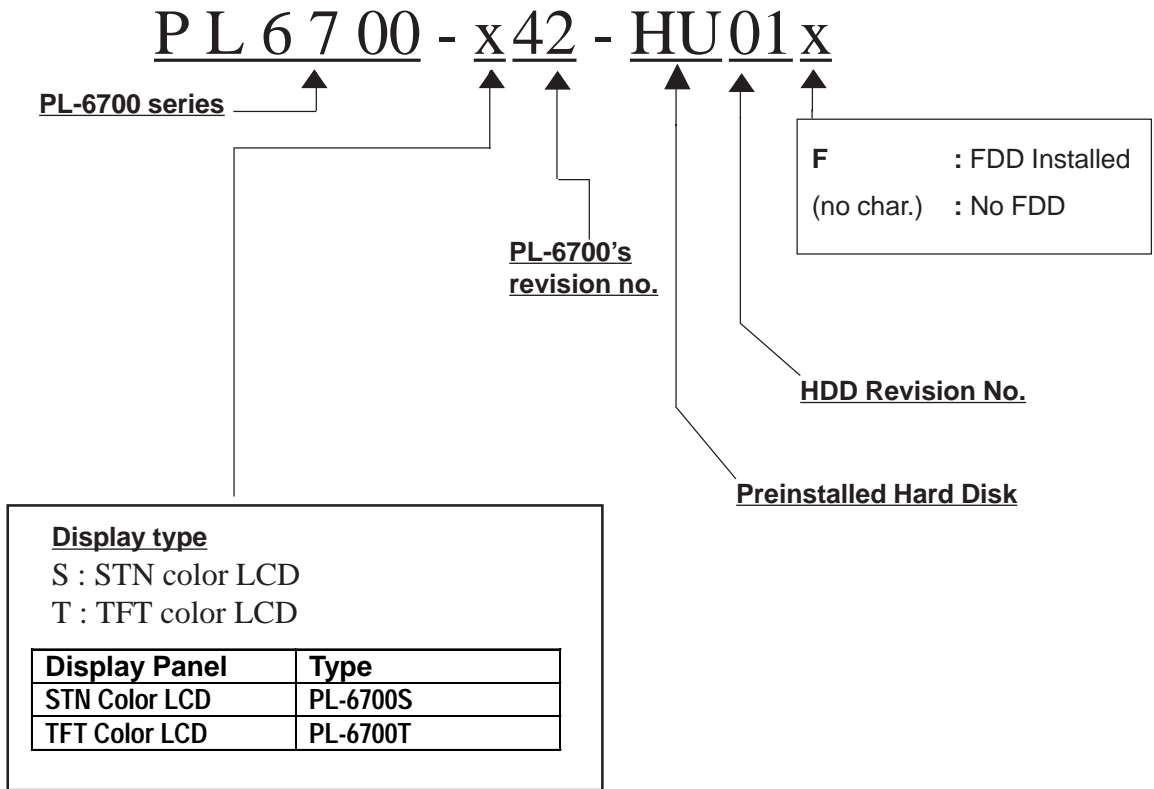

MEMO

This page intentionally left blank.

Specifications

2-1 General Specifications

1 Electrical Specifications

Operating Voltage	85V AC to 132VAC / 170V AC to 265V AC 50/60 Hz
Power Consumption	Less than 150W
Allowable Voltage Drop	less than 20ms
Voltage Endurance	1500V AC at 20mA for 1 minute (between the live wire and the grounding (FG) terminal)
Isolation Resistance	Greater than 10M Ω at 500V DC (between the live wire and the grounding (FG) terminal)

2 Environment Specifications

Operating Temperature	5 to 40°C (with HDD and FDD not installed, 0 to 40°C)
Operating Humidity	30 to 85% RH (no condensation)
Storage Conditions	-10 to 60°C / 30 to 85% RH (no condensation)
Operating Atmosphere	Free of corrosive gas
Noise Immunity (via noise simulator)	Noise Voltage: 1500Vp-p Pulse Duration: 50ns, 500ns, 1 μ s
Electrostatic Voltage Endurance	4kV
Vibration Endurance	2G: 10 to 25Hz applied in X, Y, and Z directions for 30 minutes each (0.5G when using HDD unit, 1.0G when using FDD)
Rating ^{*1} (with front panel closed)	Equivalent to IP65f (JEM1030)

*1 The front face of the GP unit, installed in a solid panel, has been tested using conditions equivalent to the standard shown in the specification. Even though the GP unit's level of resistance is equivalent to the standard, oils that should have no effect on the GP can possibly harm the unit. This can occur in areas where either vaporized oils are present, or where low viscosity cutting oils are allowed to adhere to the unit for long periods of time. If the GP's front face protection sheet becomes peeled off, these conditions can lead to the ingress of oil into the GP and separate protection measures are suggested. Also, if non-approved oils are present, it may cause deformation or corrosion of the front panel's plastic cover. Therefore, prior to installing the GP be sure to confirm the type of conditions that will be present in the GP's operating environment. If the installation gasket is used for a long period of time, or if the unit and its gasket are removed from the panel, the original level of the protection cannot be guaranteed. To maintain the original protection level, you need to replace the installation gasket regularly.



- When using any of the PL's optional devices, be sure to check that device's specifications for any special conditions or cautions that may apply to its use.
- When using a full sized expansion board, be sure to check its dimensions and shape, since they will affect the board's environment specifications, such for vibration, etc.

3 Dimensions

External Dimensions	PL6700T/PL6700S: 346W x 287H x 174D (mm)
Weight	PL6700T/PL6700S: less than 7.4kg (with HDD and FDD installed)
Dimensions (w/cover)	PL6700T/PL6700S: 419W x 287H x 174D (mm)

2-2 Performance Specifications

1 Performance Specifications

CPU		Pentium® 133 MHz (Intel Corporation)		
DRAM		Equipped with 32MB (2 DIMM sockets – max. of 64MB)		
BIOS		AWARD PC/AT Compatible		
Secondary Cache		512K		
Graphics		SVGA (800 x 600 dots) VESA 16 colors/256 colors/32K colors/64K colors		
Touch Panel	Type	Analog Resistant Film		
	Resolution	1024 x 1024		
	Interface	COM4 (uses Mouse Emulator)		
Front and Rear Interfaces	Serial	RS-232C (w/FIFO)	COM1	D-Sub 9 pin (male)
			COM2	D-Sub 9 pin (male)
			COM3	D-Sub 9 pin (male)
	Printer	Centronics Standard (DB 25-pin female connector)		
	Keyboard	PS/2 Interface (mini DIN 6 pin female connector) side & front		
	Mouse	PS/2 Interface (mini DIN 6 pin female connector) side		
	RGB Output	Analog RGB Output		
	Disk I/F	FD Unit	Front Access 2 modes	
		IDE	2.5 inch HDD I/F	



- Be aware that not only does the Hard Disk have a fixed lifetime, but that accidents can always occur. Therefore, be sure to back up your Hard Disk's data regularly, or prepare another Hard Disk unit that can be used for backup.
- The Hard Disk lifetime value given here is for reference purposes only. Unforeseen factors (environmental changes, etc.) may cause it to actually be shorter.

2 Display Functions

	PL6700T	PL6700S
Display Type	TFT Color LCD	STN Color LCD
Pixel Density	800 x 600 (pixels)	800 x 600 (pixels)
Effective Display Area	247W x 185H (mm)	247W x 185H (mm)
Dot Pitch	0.3 x 0.3 (mm)	0.3 x 0.3 (mm)
Display Colors	260,000 colors	8 colors (frame thinning produces graduated halftones)
Contrast Adjustment	Not Possible	Possible (via adjustment knob)
Backlight *1	Replaceable	Replaceable



*1 The PL's backlight should be replaced by only an authorized repairman. For information about this service, please contact your nearest authorized distributor.

3 Expansion Slots

	Board Size	Power Supply
1 st Slot (ISA)	163 x 122 (mm)	5V : 4A 12V : 1.5A (total for all 4 slots)
2 nd Slot (PCI/ISA)	163 x 122 (mm)	
3 rd Slot (PCI/ISA)	250 x 122 (mm)	
4 th Slot (ISA)	250 x 122 (mm)	



- Slots 2 and 3 can be used for either PCI or ISA cards.
- The distance (pitch) between the 1st and 4th slots and their adjacent slots is 20mm. The pitch between the 2nd and 3rd slots is 25mm.
- Slots 3 and 4 can support full-sized boards. However, when using a full-sized board, the top edge of the board will extend beyond the standard case. In this case the optional full-sized cover is recommended.



3-2-5 Installing an Expansion Board

- The power requirement when using all four expansion slots is 5V : 4A / 12V : 1.5A.

2-3 Interface Specifications

1 Printer Interface (LPT1)

D-sub 25 Pin (Female)

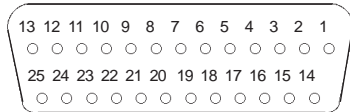

O.D : Open Drain
T.S : 3 state I/O
TTLIN : TTL Input

Pin No.	Signal Name	Direction	Elect. Specif.	Pin No.	Signal Name	Direction	Elect. Specif.
1	STROBE	OUT ^{*1}	O.D	14	AUTOFD	OUT	O.D
2	DATA0	OUT ^{*1}	T.S	15	ERROR	IN	TTLIN
3	DATA1	OUT ^{*1}	T.S	16	INIT	OUT	O.D
4	DATA2	OUT ^{*1}	T.S	17	SLCTIN	OUT	O.D
5	DATA3	OUT ^{*1}	T.S	18	GND		
6	DATA4	OUT ^{*1}	T.S	19	GND		
7	DATA5	OUT ^{*1}	T.S	20	GND		
8	DATA6	OUT ^{*1}	T.S	21	GND		
9	DATA7	OUT ^{*1}	T.S	22	GND		
10	ACKNLG	IN	TTLIN	23	GND		
11	BUSY	IN	TTLIN	24	GND		
12	PE	IN	TTLIN	25	GND		
13	SLCT	IN	TTLIN				

^{*1} Output: The Input and Output settings used will depend the BIOS set up screen settings used.

2 Keyboard Interface

Mini - DIN 6 pin (Female)

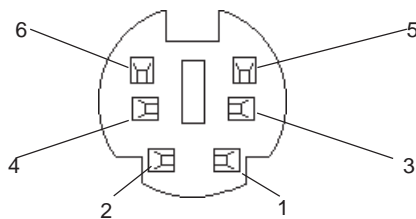

(The PL's front and side connectors are the same)

Pin No.	Signal Name
1	KEY DATA
2	NC
3	GND
4	+5
5	KEY CLK
6	NC
SHIELD	GND

Recommended Keyboard: Any PS-2 type keyboard

3 Mouse Interface

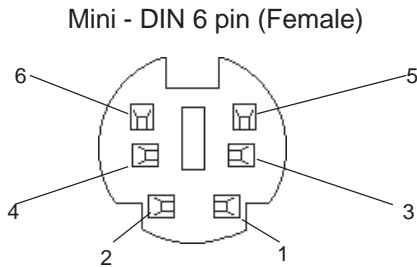

Pin No.	Signal Name
1	Mouse DATA
2	NC
3	GND
4	+5
5	Mouse CLK
6	NC
SHIELD	GND

4 RS-232C Interface (COM1/COM2/COM3)

D-sub 9 pin (Male)

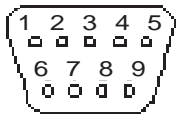

Pin No.	Signal Name	Pin No.	Signal Name
1	CD	6	DSR
2	RXD	7	RTS
3	TXD	8	CTS
4	DTR	9	RI
5	GND		

Screw Size: (4-40): Inch Type

5 CRT Interface (Video)

D-sub 15 pin (Male)

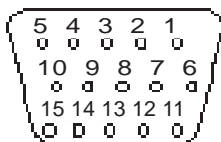

Pin No.	Signal Name	Pin No.	Signal Name
1	R	9	NC
2	G	10	GND
3	B	11	NC
4	NC	12	RESERVE (NC)
5	GND	13	H.SYNC
6	R-GND	14	V.SYNC
7	G-GND	15	RESERVE (NC)
8	B-GND		

6 Contrast Adjustment (PL-6700S only)

The contrast adjustment knob, located inside the PL's front face maintenance cover, can be adjusted to change the PL's contrast setting.



Since the PL's contrast is factory set at the optimal level, adjustment is usually not necessary.

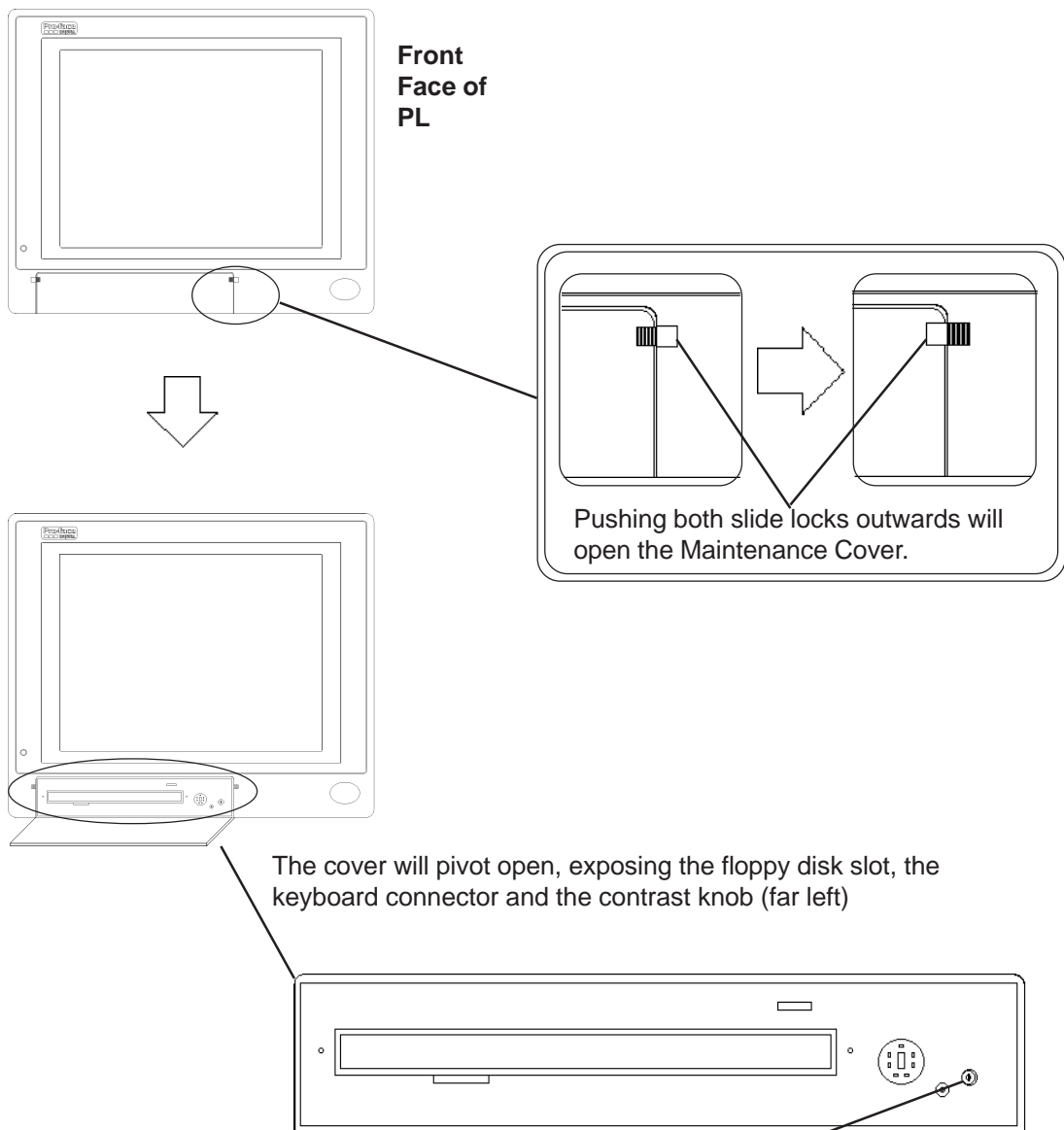

- Turning the contrast knob to the right (clockwise) makes the screen brighter; turning it to the left makes the screen darker.
- A small, fine-tipped plastic screwdriver is recommend for this adjustment.

2-4 PL External Features

The diagram illustrates the external features of the PL-6700T unit. The top view shows the front panel with a large display area, a touch panel, and a front maintenance cover. A callout labeled 'With cover opened:' shows the internal components, including a keyboard connector, a floppy disk insertion slot, and an IrDA unit. The bottom view shows the rear panel with various connectors and expansion slots. Callouts identify the RS-232C connectors (COM1, COM2, COM3), the HDD cover, the analog RGB connector, the printer connector (LPT1), and the expansion slots.

Display Area
Display output area. The built-in SVGA controller supports PC compatible architecture.

Touch Panel
This high-resolution analogue touch panel allows you to configure a keyboard-less system.

Front Maintenance Cover
Open this cover to connect the optional FDD unit or memory card interface unit.

IrDA
When the optional PL-IR100 is installed, infra-red signals are sent and received by this unit.

Keyboard Connector
A PS/2 compatible keyboard is connected here.

Floppy Disk Insertion Slot
This slot is used if the optional FDD unit or memory card interface is installed.

RS-232C Connector (COM1)
RS-232C Connector (COM2)
RS-232C Connector (COM3)
RS-232C interfaces (DB 9-pin male connectors), which allow communication with other computers or connection to peripheral devices.

HDD Cover
When an HDD is installed, this cover is removed.

Analog RGB Connector
A PC/AT compatible multi-scan monitor can be connected here.

Printer Connector (LPT1)
Centronics standard interface (DB 25-pin female connector), which connects a parallel device, such as a printer (supports ECP/EPP)

Expansion Slots
A variety of expansion boards, both Digital's and other makers, can be installed here.

“3-1 Available Options and Expansion Boards”
The PL-6700T/PL-6700S are both equipped with four (4) expansion slots. Seen from the front of the unit, these slots are numbered 1, 2, 3 and 4.

(Drawings shown here are for the PL-6700T unit)

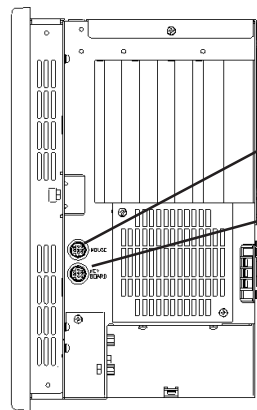

Keyboard Connector

A PS/2 compatible keyboard can be connected here.

Mouse Connector

A PS/2 compatible mouse can be connected here.

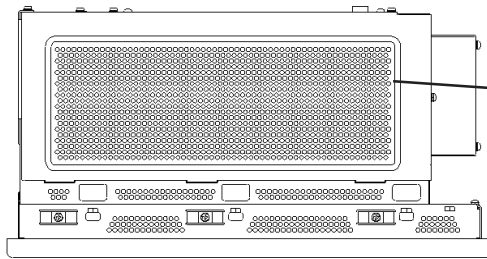

Rear Maintenance Cover

Remove this cover to install the optional DIM module, or an expansion board.

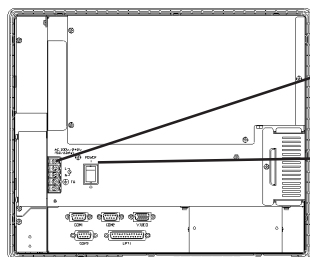

Power Input Terminal Strip

Connect the 100V/240V AC power cord here.

Power Switch

Use this switch to turn the PL's power ON or OFF.

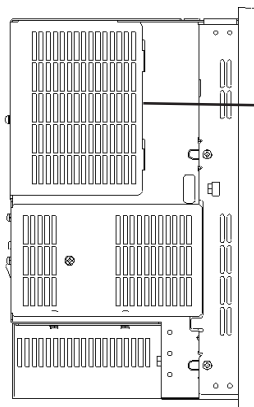

Half Cover

When attaching the optional DIM module or other optional expansion boards, you will need to remove this cover.



- When attaching peripheral units to the PL, be sure the PL's power cord is disconnected from the main power supply.
- To avoid an electrical shock, be sure to disconnect the PL's power cord from the power supply before connecting the cord's power terminals or any peripheral devices to the PL.

2-5 PL Dimensions

1 PL-6700T, PL-6700S:

<General Dimensions>

(Unit: mm - excluding projections)



For detailed PL dimension information, please contact your local PL dealer.

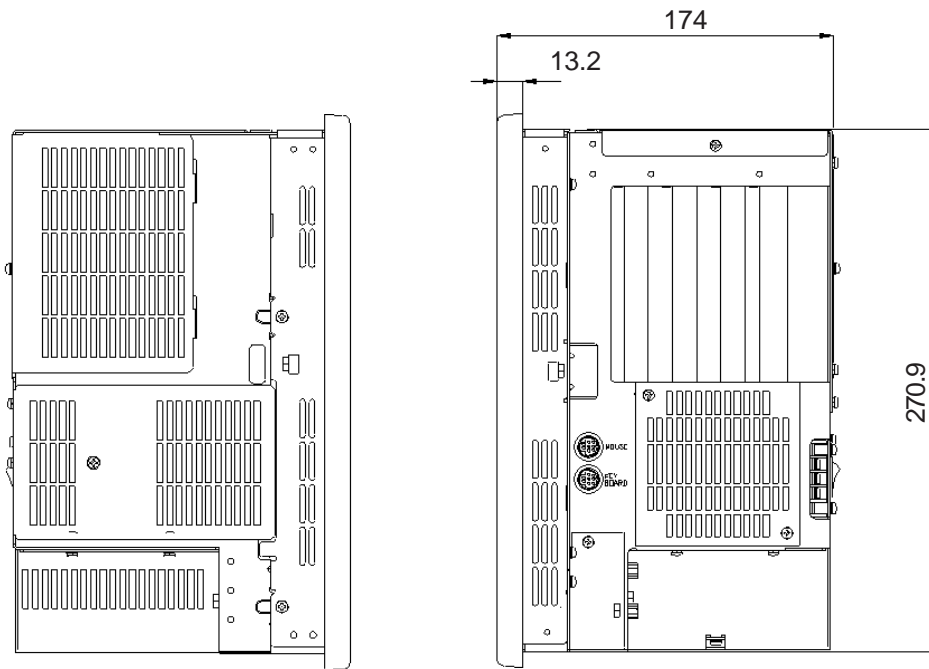
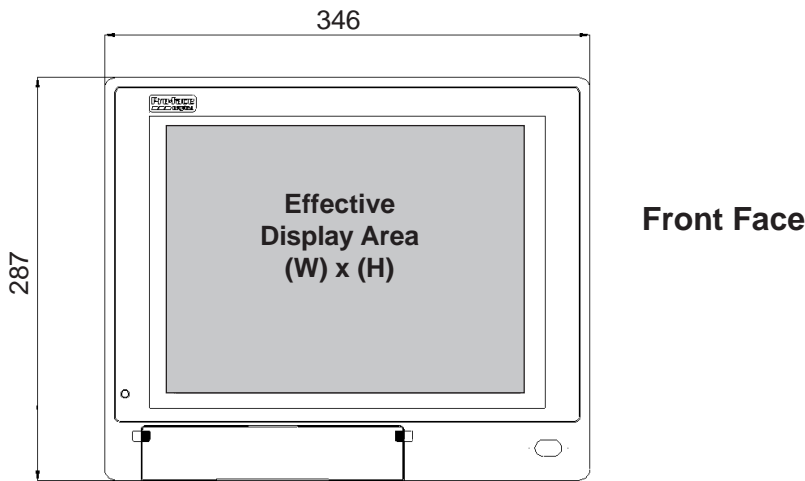

Side View

Side View
(Opposite Side)

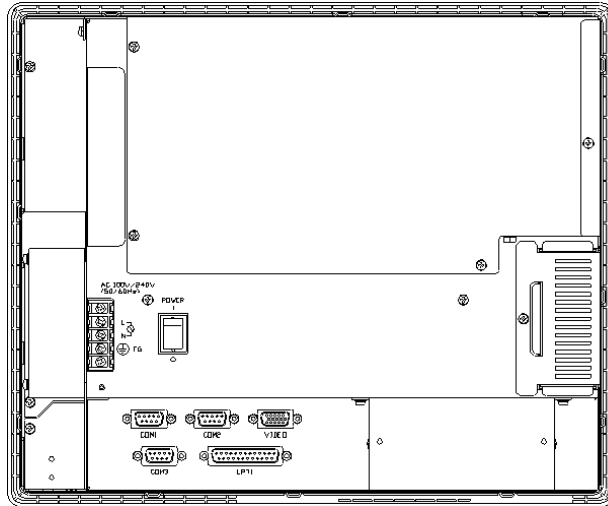

Rear Face

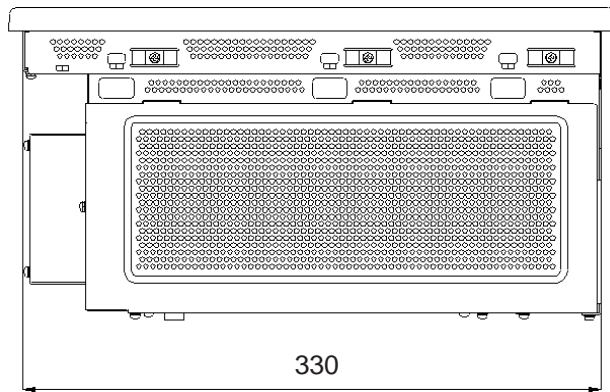

Top Face

2 Full Sized Cover Attachment Dimensions

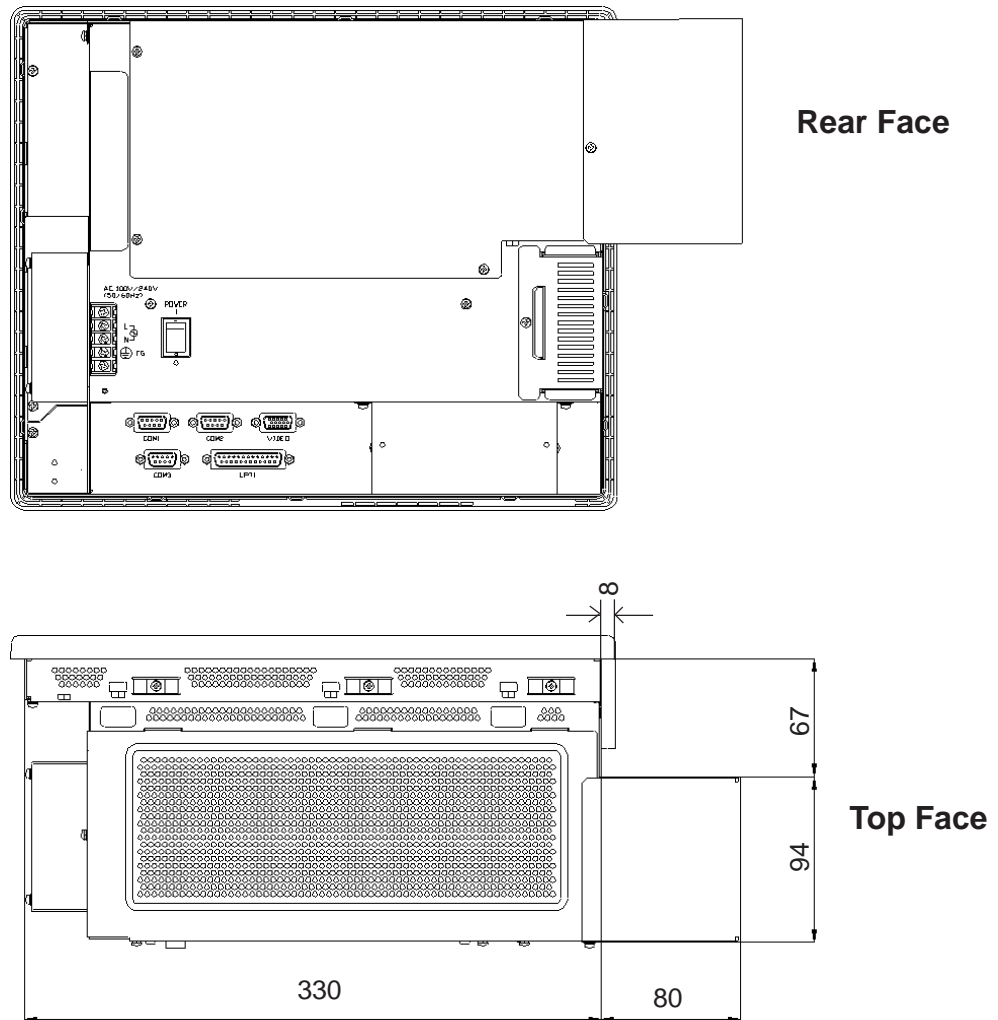

- When using a full-sized board and the PL's full-sized cover (PL-FC100), be sure that the PL is mounted in its attachment panel/cabinet before starting this work. The PL's full sized board and cover cannot be attached first and then the unit installed, due to size differences.
- When using a full sized expansion board, be sure to check its dimensions and shape, since they will affect the board's environment specifications, such for vibration, etc. The specifications given in this manual are without the full-sized cover attached. Please contact your nearest Proface dealer when using a full-sized expansion board.

3 Installation Slot Dimensions

(Unit: mm)

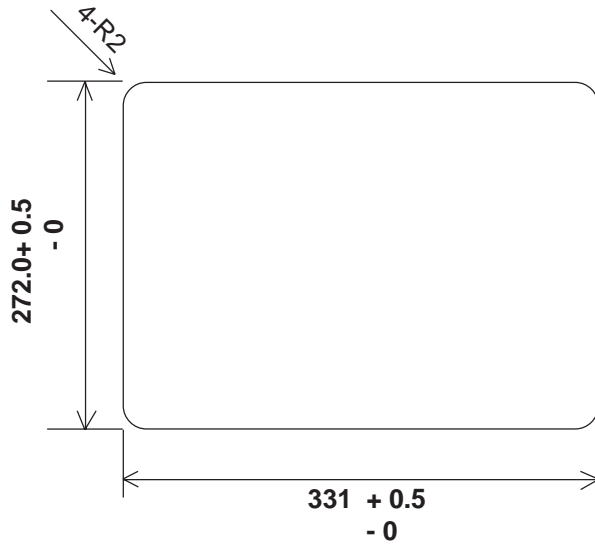

- Be sure the thickness of the panel is from 1.6 to 10 mm.
- To insure that the PL's water resistance is maintained, be sure to install the PL into a panel that is flat and free of scratches or dents.

Installing Optional Units and Expansion Boards

The User can install a variety of optional units and expansion boards made by Digital in the PL, as well as a number of commercially available ISA-bus compatible boards. This chapter describes both the products that can be installed in the PL and how to install them.

3-1 Available Options and Expansion Boards

Digital Electrical Corporation Optional Products

Name	Model	Description	Installation Location
DIM Module	PL-EM220	32MB SDRAM Main memory module for expansion.	Installed inside the PL.
	PL-EM230	64MB SDRAM Main memory module for expansion.	Installed inside the PL.
HDD Unit	PL-HD200	Built-in type special purpose 2.5 inch HDD unit.	Used when replacing the existing HDD unit.
FFD Unit	PL-FF200	20MB flash file disk with IDE interface.	Installed inside the PL.
FDD Unit	PL-FD200	PC/AT compatible 3.5 inch FDD unit.	Installed inside the PL.
-5V/-12V Power Unit	PL-PW100	Provides -5V and -12V power to the expansion slots. Allows each of the 4 slots to draw up to 200mA.	Installed inside the PL.
CD-ROM Unit	PL-DK200	IDE compliant CD-ROM unit (Includes special connection cable)	Attached to the connector on the rear side of PL.
Full-sized cover	PL-FC200	Attached when ISA bus full sized board is used in the expansion slot.	Installed inside PL's Maintenance Cover.
IrDA Unit (under development)	PL-IR100	IrDA (Ver. 1.0) compatible infrared data transmission module.	Installed inside PL's IrDA cover.



- *Since the PL-6700's hard disk is a precision instrument, periodic maintenance is recommended to insure its correct operation.*

Commercially Available Products

Product	Description	Installation Area
PCI/ISA Bus compatible board	<p>In all PL-6700 units, slots 1 and 2 can accommodate boards up to 163mm long. Slots 3 and 4 can accommodate boards up to 250mm long.</p> <p>■ All PL-6700 slot heights are 122mm. When using the full-sized cover, be sure to use boards that are no more than 338mm long in slots 3 and 4.</p> <div style="text-align: center;"> <p>The diagram illustrates a board being inserted into a slot. It shows the board's length, its height (Height₁), and the height of the attachment plate (Height₂). The attachment plate is shown extending beyond the board's edge. Arrows indicate the insertion direction.</p> </div>	Into the PL's expansion slots.

Since the steel attachment plate for the board is longer than the board (Height₁), be sure to measure the board's height from Height₂



<Expansion Slot's Width and Power Supply>

- Check that your expansion board's "foot" matches the width of the expansion slot. Slots 1 and 4 are 20 mm wide, and slots 2 and 3 are 25 mm wide. Be sure the width of your expansion board's width matches that of the intended slot.
- Since the PL does not supply -5 and -12 V current, ISA(AT)-bus compatible boards requiring -5 or -12 volts can be used only if the optional PL-PW100 power supply is installed.

<Commercially Available Boards>

- Certain commercially available boards may not be compatible with Digital's PL unit. Installing incompatible boards may result in either damage to or failure of the PL and will void your warranty.

<PCI Bus>

- Within the entire range of PCI buses currently available on the market, there may be certain devices which will not operate when used with the PL-6700. Prior to the use of any PCI Bus, be sure to contact your local PL distributor.

<Main Memory>

- Be sure to use only DIM modules manufactured by Digital. Installing other DIM modules may result in either damage to or failure of the PL, and will void your warranty.

<When using Standard PC Peripheral Devices>

- Within the range of peripheral devices currently available on the market, there may be certain devices which will not operate correctly when used with the PL-6700. Prior to using any peripheral device, be sure to confirm that it will operate normally with the PL. Installing incompatible boards may result in either damage to or failure of the PL and will void your warranty.

3-2 Installing Options and Expansion Boards



WARNING

To avoid electric hazards, be sure to turn the PL's power OFF before installing any optional units or expansion boards.



Use a screw driver to loosen or tighten the screws. Be careful not to over-tighten any screws, since it may damage the equipment.

Be careful when removing or inserting any screws inside the body of the PL.

1 Attaching the PL's Support Leg



Be sure to remove the support "leg" when placing the PL into a panel or cabinet, since this could damage either the leg, the PL or the panel.

In order to perform development using the PL-6700, an additional "leg" (support) is supplied with the unit to stabilize it when placing it on a table top (i.e. when the unit is not mounted in a panel), due to the irregular shape of the unit's chassis. The procedure for attaching this leg is described below.

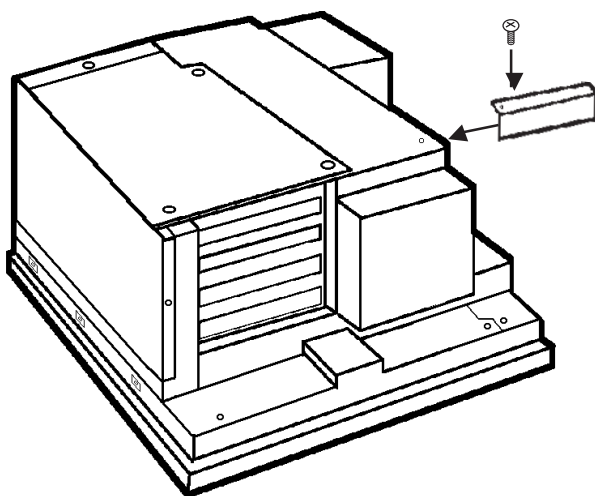

1) Attach the support leg to the PL's chassis, as shown here.

2 Installing the DIM Module (PL-EM200)



Since DIM module sockets are easy to break, be sure to install the DIM module very carefully.

The PL-6700 comes with a single, 32MB module pre-installed. There is one more empty socket that can be used and the procedures that follow describe how to install a second DIM module in that socket.

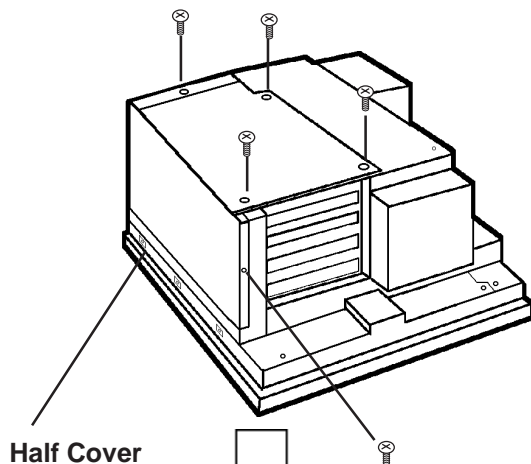

- 1) Unscrew the five (5) attachment screws used to hold the rear maintenance cover and half-cover in place.

Half Cover

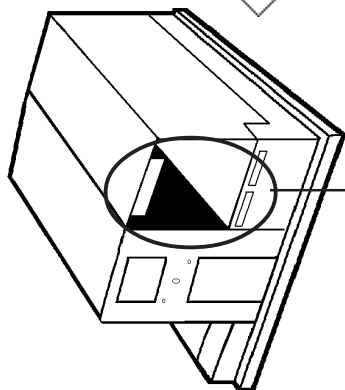

- 2) Remove the half-cover (it will pivot out and away from the unit) and then the rear maintenance cover.

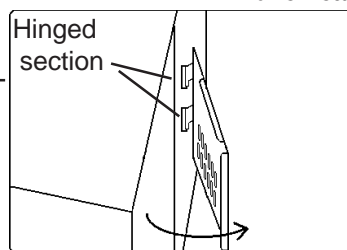

Swings out away from the unit.

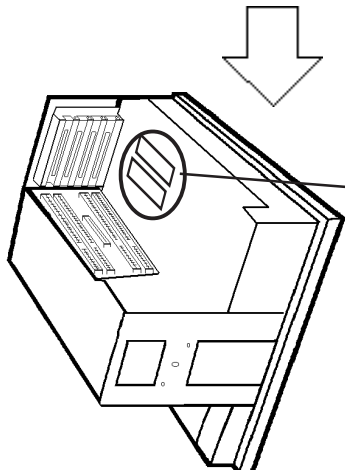

- 3) Locate the two DIM socket holders.

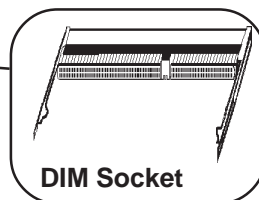

Optional Units and Expansion Boards

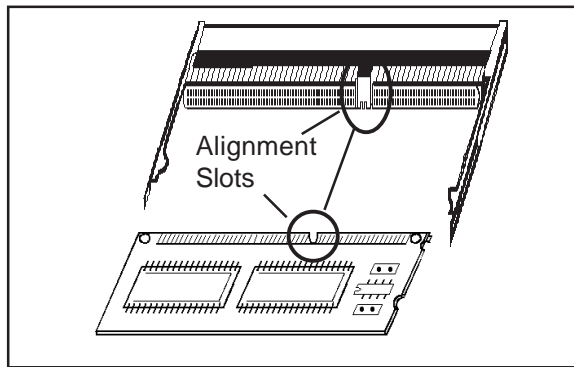

- 4) Position the module so that its alignment slot and the DIM module's alignment slot are aligned.

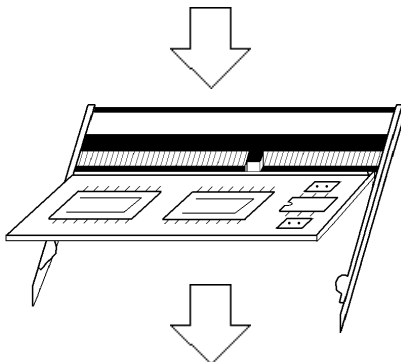

- 5) Position the module so that its contacts are directly in front of the DIM socket and tilted up slightly.

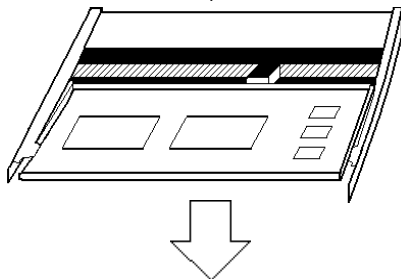

- 6) Then, tilt the module down so that the module and socket's contacts are parallel.

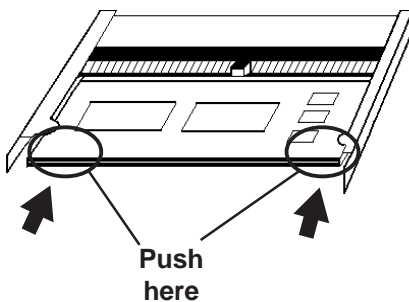

- 7) Push the module slowly but firmly into the socket, until the module's clips lock in place.



Be sure to only push on the points shown here. Pushing on any other point may cause the module to break.

[To Remove the DIM Module]

When removing the module from the socket, please spread the socket's sides as shown.

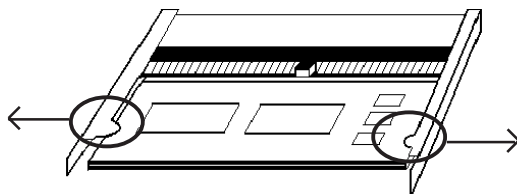

3 Removing or Installing the FDD Unit (PL-FD100)

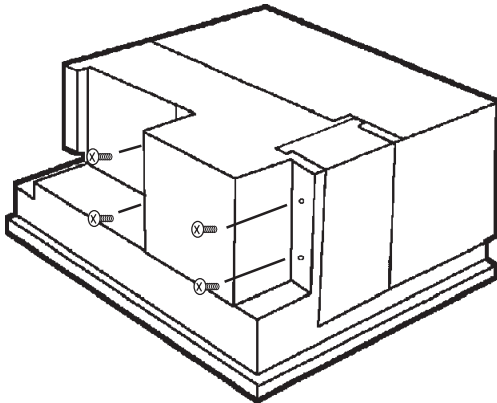

- 1) Remove the floppy disk unit cover's four attachment screws.

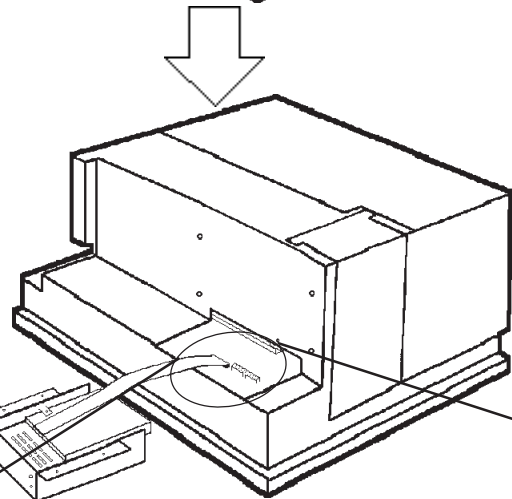

- 2) Around the FDD connection cable is fitted a black plastic pinch collar (Part of the PL's connector - see detail 1, page 3-7).

This pinch collar must be pulled up to release the connection cable's end tab.

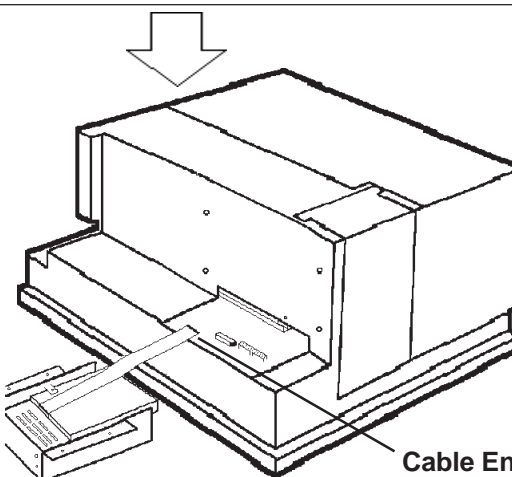
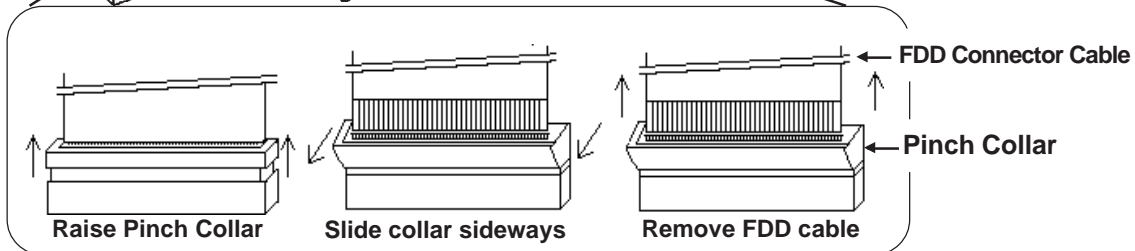

- 3) Remove the cable end from the FDD connector.

NOTE When either exchanging or installing the PL-FD100, before screwing in the unit's attachment screw, be sure that the FDD Connection Cable is attached and the abovementioned connector's pinch collar is in place.

4 Removing or Installing the HDD Unit (PL-HD100)

Follow the steps given below when attaching or detaching the PL-HD100.



Since the PL-6700 is a precision instrument, be sure not to jar or shake it unnecessarily.

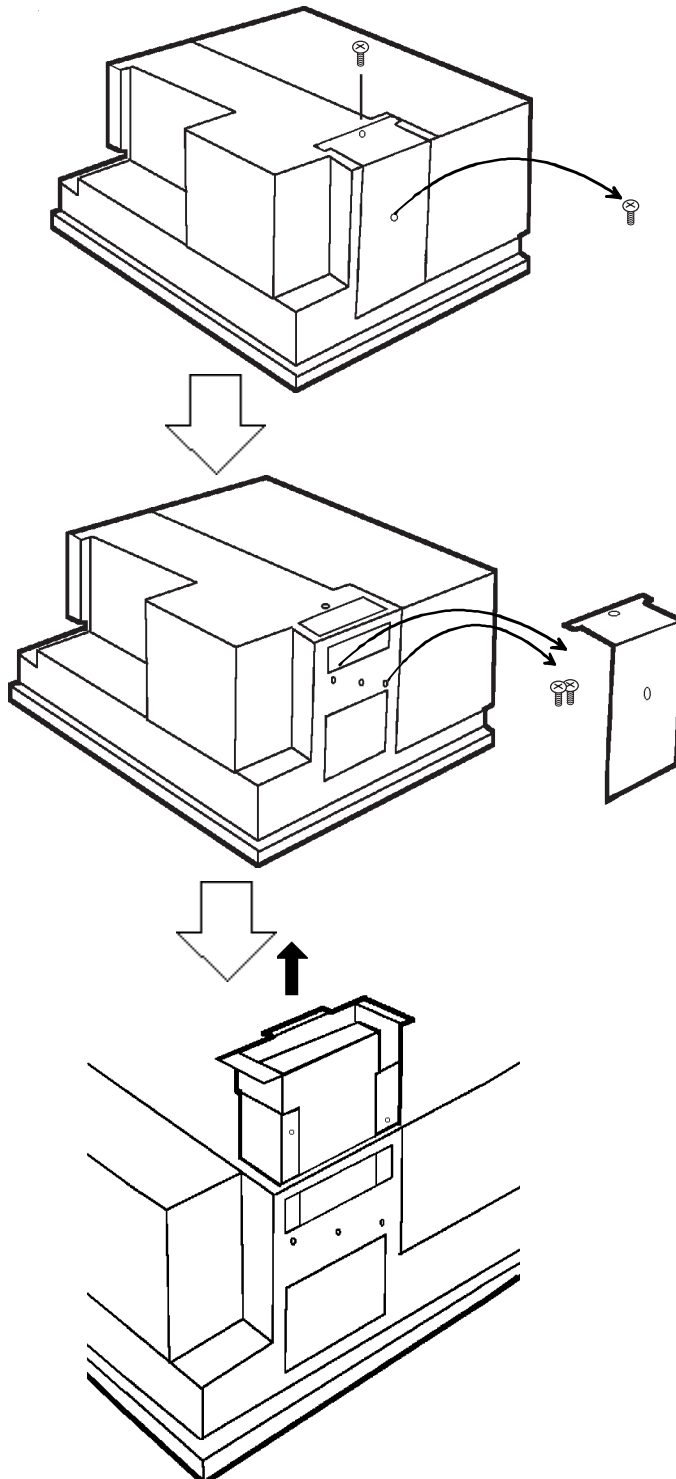

1) Unscrew the HDD unit's protective cover's 2 attachment screws.

2) Remove the HDD unit's cover and unscrew the HDD unit's 2 set screws.

3) Pull out the HDD unit from the PL-6700.

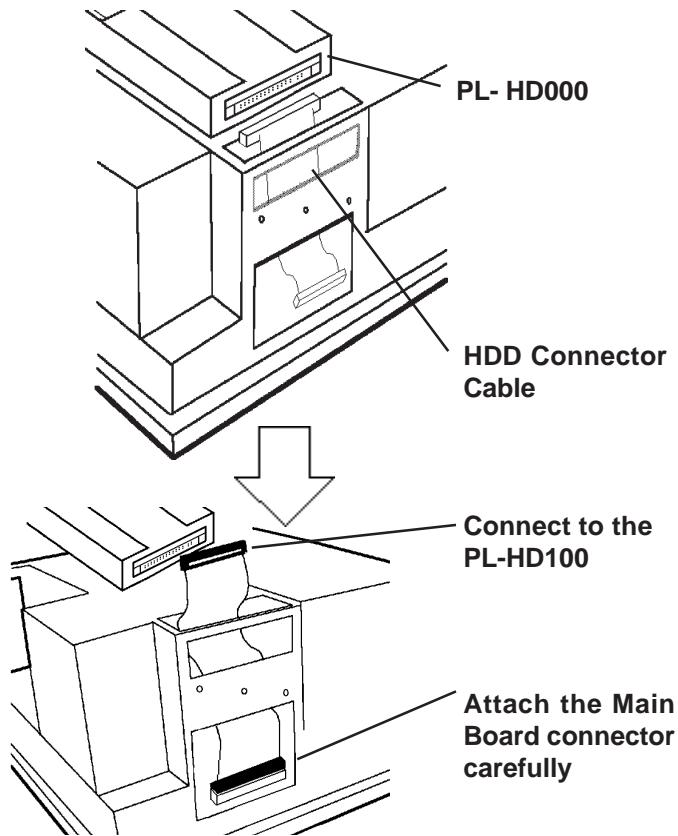

- 4) Detach the PL-HD000's connection cable from the unit.



- Be sure not to bend any of the HDD's connector pins while removing the cable's connector.

- 5) Reattach the connection cable to the PL-HD100's connector (See note below).



Important

If the hard disk unit's connector is attached incorrectly, there is a possibility of damage to the unit. Please follow the instructions given here carefully.

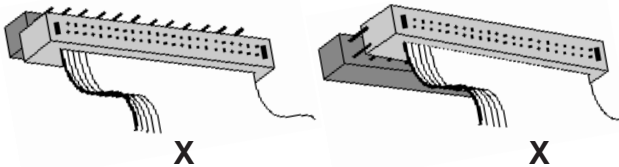

<Figure 1 - PL-HD100 Connector>
Cable Inversion Prevention Pin (Removed)

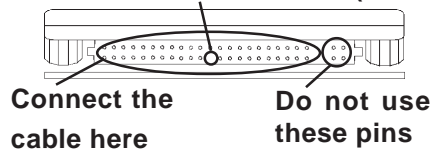

Be sure the hard disk unit cable's main board connector is not skewed from its correct attachment position (see above examples). Incorrect attachment can cause damage to the unit.

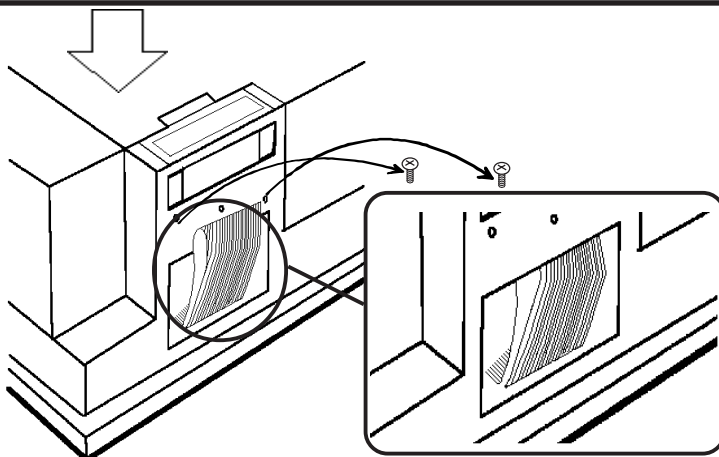

- 6) Secure the HDD unit in place with its 2 attachment screws.

- 7) Fold the HDD's cable so that it looks like the picture, and insert the folded cable's end into the HDD's holder slot.



- Be sure that the cable is not pinched by either the PL's chassis or the attachment screws.

5 Installing an Expansion Board

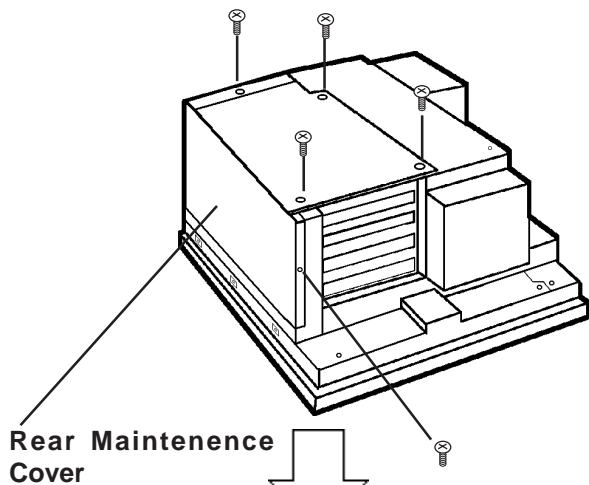

1) Unscrew the five (5) attachment screws used to hold the rear maintenance cover and half-cover in place.

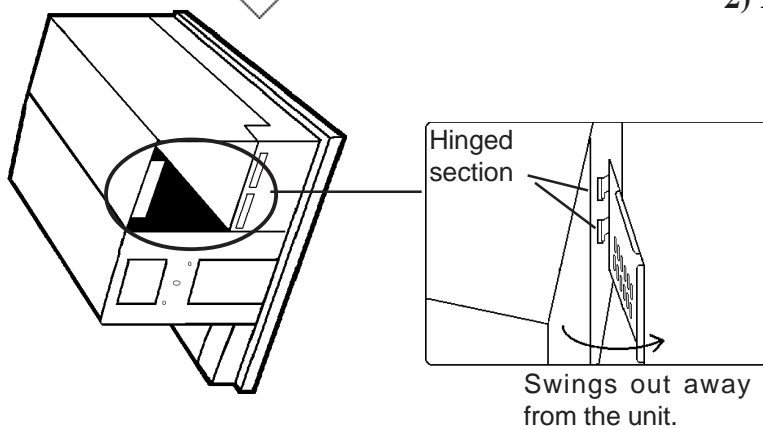

2) Remove the half-cover (it will pivot out and away from the unit) and then the rear maintenance cover.

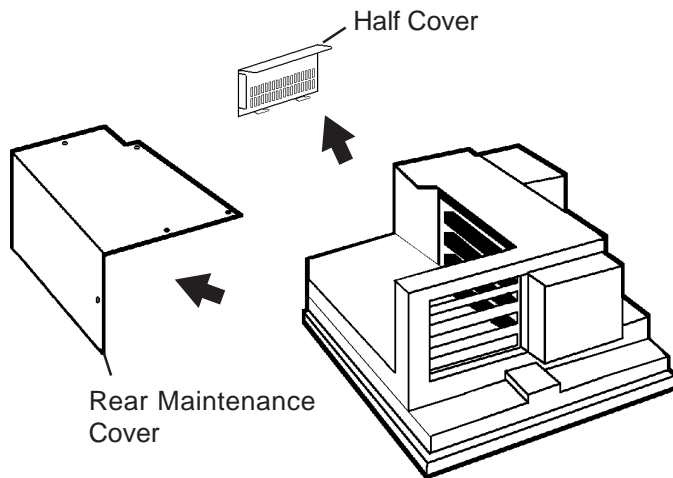

3) Remove the rear maintenance cover and the half cover.

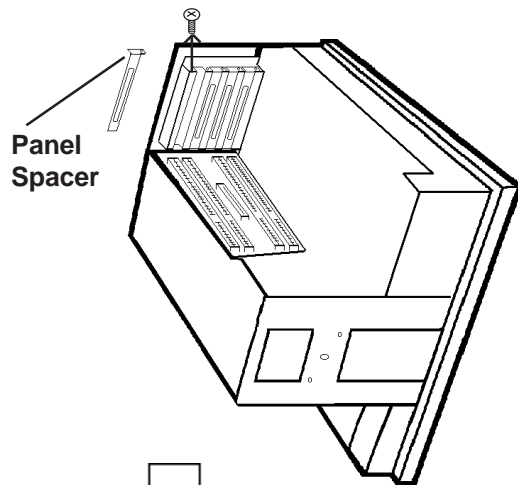

- 4) Remove the desired expansion slot's blank panel by unscrewing the panel's attachment screw.

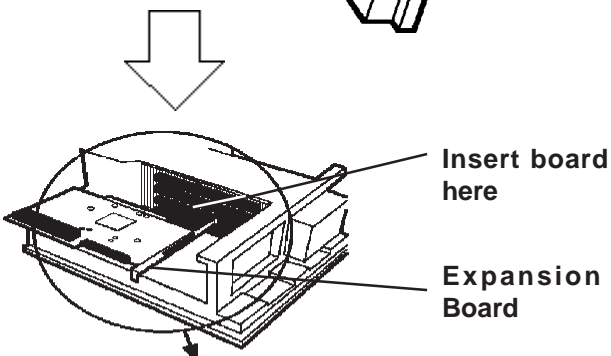

- 5) Gently insert the expansion board into the expansion slot.

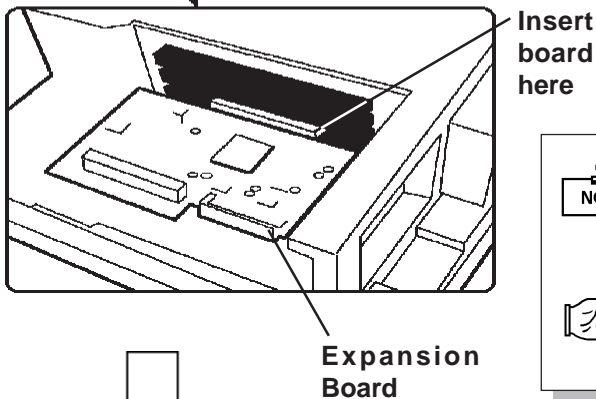

Attaching a full-sized expansion board will cause the end of the board to extend outside of the expansion board area.



3-1 Available Options and Expansion Boards

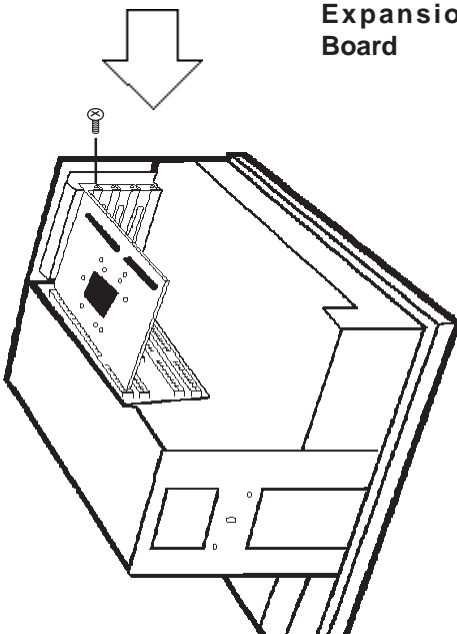

- 6) Re-attach the blank panel's attachment screw (1).

After the board is secured in position, replace the rear maintenance cover and attach it in place with the attachment screws.

- 7) After the rear maintenance cover is secured in position, reattach the half cover and secure it in place.

6 Installing the IDE Slave Adaptor (PL-SA100)

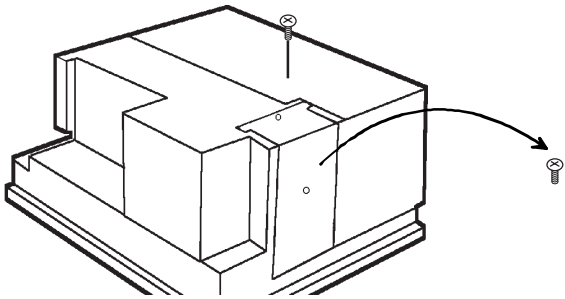

1) Unscrew the HDD unit's protective cover's 2 attachment screws.

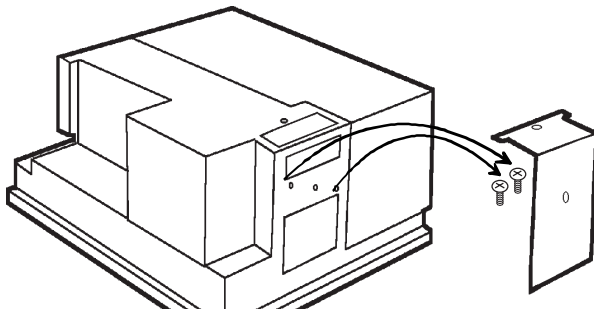

2) Remove the HDD unit's cover and unscrew the HDD unit's two (2) set screws.

! Important

If the hard disk unit's connector is attached incorrectly, there is a possibility of damage to the unit. Please follow the instructions given here carefully.

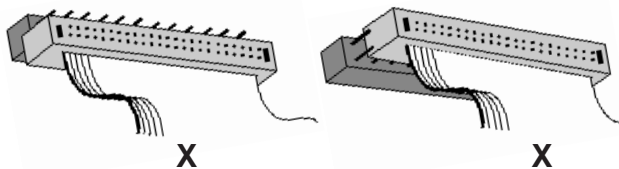

<Figure 1 - PL-HD100 Connector>
Cable Inversion Prevention Pin (Removed)

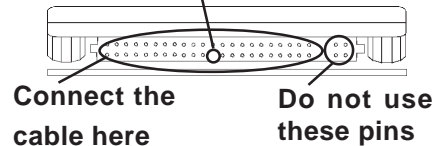

Be sure the hard disk unit cable's main board connector is not skewed from its correct attachment position (see above examples). Incorrect attachment can cause damage to the unit.

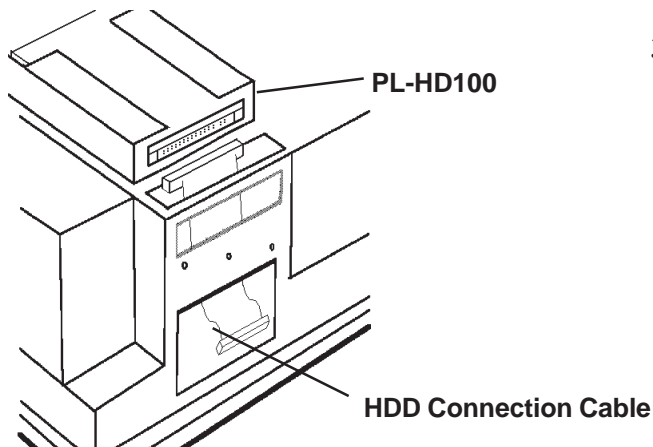

3) Disconnect the PL-HD100 unit from the HDD connection cable.

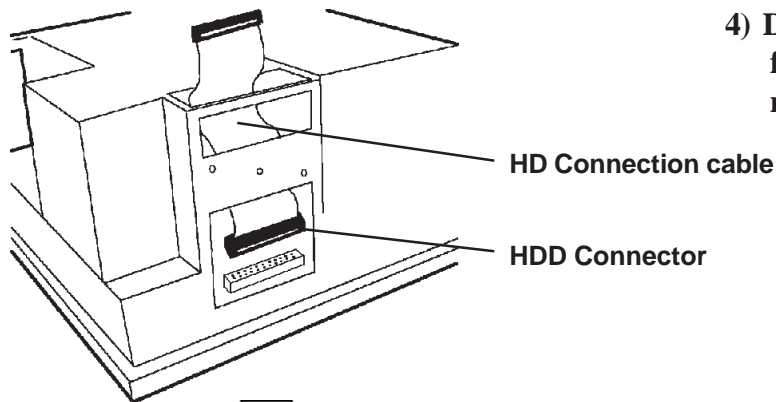

- 4) Disconnect the HD connection cable from the Main Board's HDD connector.

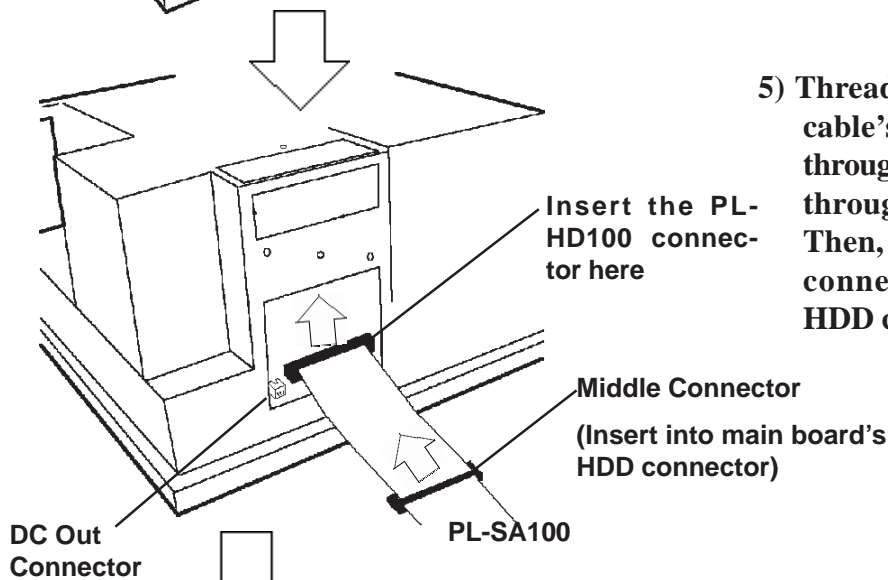

- 5) Thread the PL-SA100 connection cable's PL-HD100 cable connector through the slot shown here and up through to the top of the chassis. Then, connect the cable's middle connector to the main board's HDD connector.

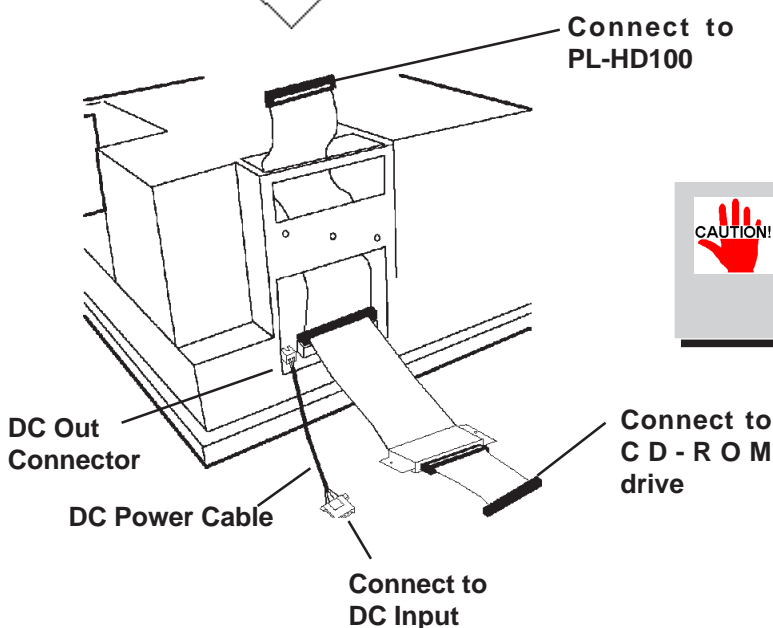

- 6) Connect the PL-SA100's additional DC power cable to the DC OUT connector.



Be sure to connect the CD-ROM drive connector cable's #1 pin mark side with the IDE interface's #1 pin.

- 7) Last, connect the PL-HD100 to the end of the cable and use the attachment screws to fix the HD unit in place. (Refer to page 3-10, Step 2)

Chapter

4

4-1 Installation Cautions

4-2 Installing the PL

4-3 Wiring the PL

Installation and Wiring

This chapter explains how to install and wire the PL-6700, as well as the cautions required both before and during installation.

4-1 Installation Cautions

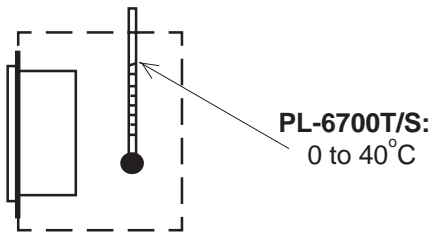

1) Temperature Related Cautions

Be sure to confirm that the area near the PL will be within the allowable temperature range. If this area's temperature exceeds the allowed limit, a machine breakdown can occur.

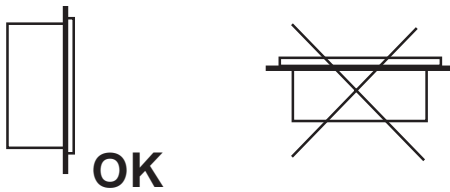

2) Installation Positioning Cautions

Be sure to install the panel in an upright (vertical) position.

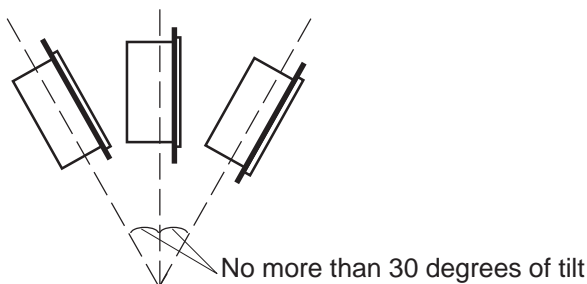

Also, be sure that the panel's viewing angle is tilted no more than 30 degrees from parallel to the operator (i.e. directly in front).

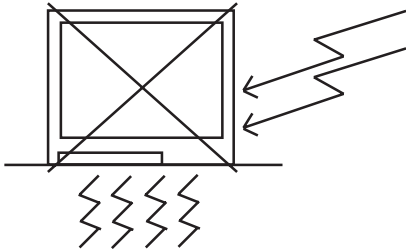

3) Vibration Related Cautions

Be sure to protect the PL from excessive vibration or jolting. These kinds of shocks can cause the PL to malfunction.

PL Condition	Shock Strength
When using the HDD	Up to 0.5G
When using the FDD	Up to 1.0G
When using no drives	Up to 2.0G



- Be sure to not move the PL unit while the HDD is starting up. This can lead to a machine breakdown.
- When using a fan to cool the PL unit, be sure that the fan does not point directly at either of the PL's disk drive units, i.e both the hard disk and the floppy disk.

4-2 Installing the PL

1 Installation Procedures

Follow the steps given below when installing the PL-6700.

Confirm the moisture resistant seal's seating

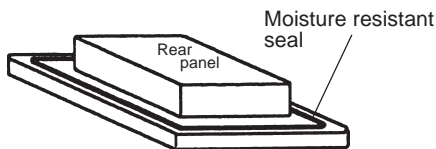

Place the PL on a level surface with the display panel facing downward. Check that the PL's moisture resistant seal is seated securely into the seal's groove, which runs around the perimeter of the panel's frame.

Create a mounting hole

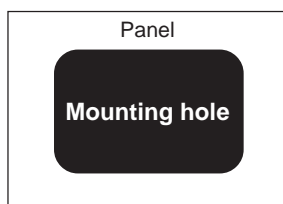

Create a hole for mounting the PL, like that pictured here. These two items, the moisture resistant packing and the mounting brackets are required when installing the PL.

See "2-5 PL Dimensions"

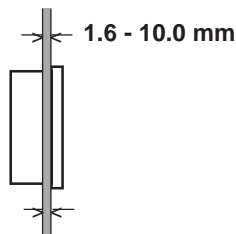

- To obtain the maximum degree of moisture resistance, be sure to mount the PL on a smooth, flat surface.
- The panel itself can be from 1.6 to 10 mm thick.



To enhance the PL's maintainability, operability and ventilation, allow at least 50 mm or more clearance between the PL and any other objects. (The clearance must be large enough to allow you to insert or remove expansion boards and to attach connectors.)

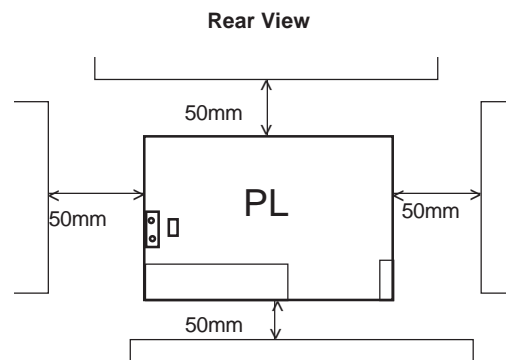
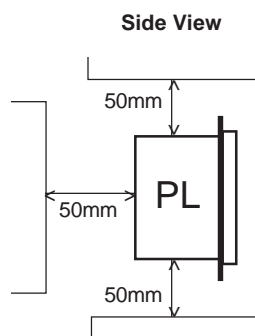

- Be sure that the panel's viewing angle is tilted no more than 30 degrees from parallel to the operator (i.e. operator is directly in front).

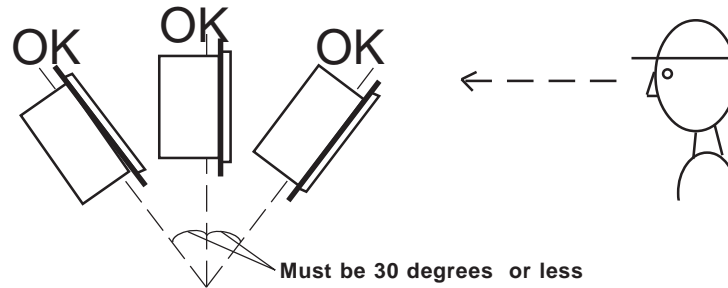

- Avoid placing the PL next to other devices that might cause overheating.
- Avoid using the PL where the ambient temperature will exceed 40°C.
- Keep the PL away from arc-generating devices such as magnetic switches and non-fuse breakers.
- Avoid using the PL in environments where corrosive gases are present.

Insert the PL into the installation slot

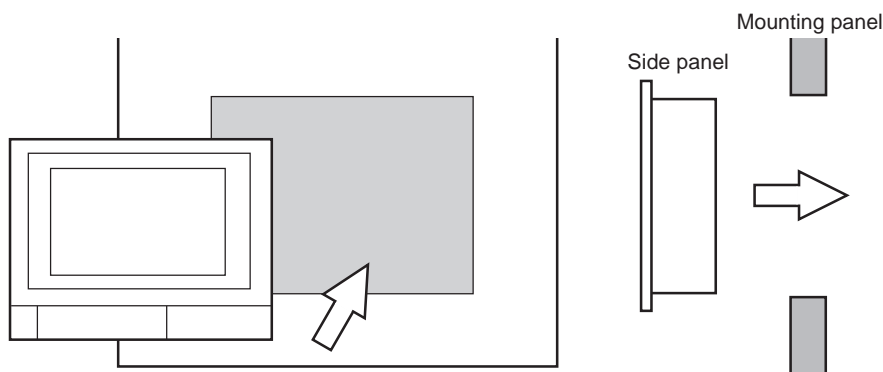

Attach and Secure the Rear Attachment Brackets

- 1) Locate the PL's eight (8) attachment holes, located on the top, bottom, and sides of the PL.

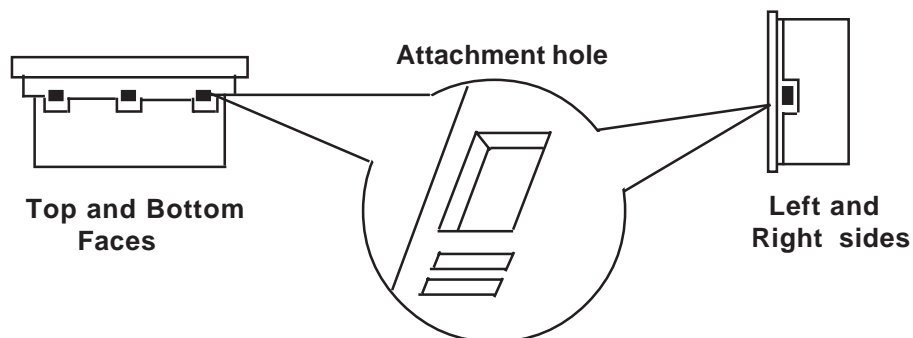

Optional Units and Expansion Boards

- 2) Insert each bracket into its attachment hole.

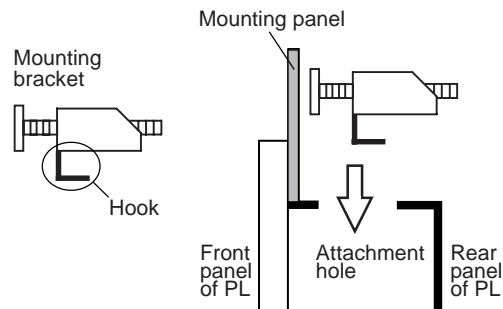

- 3) Insert each mounting bracket into aattachment hole, and slide the bracket backwards until it stops.

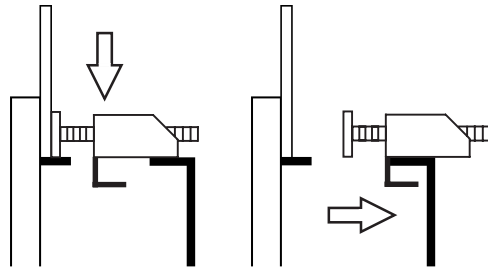

- 4) Use a screwdriver to tighten the bracket's adjustment screw. To ensure a high degree of moisture resistance, the torque should be 0.5 to 0.6 N•m.

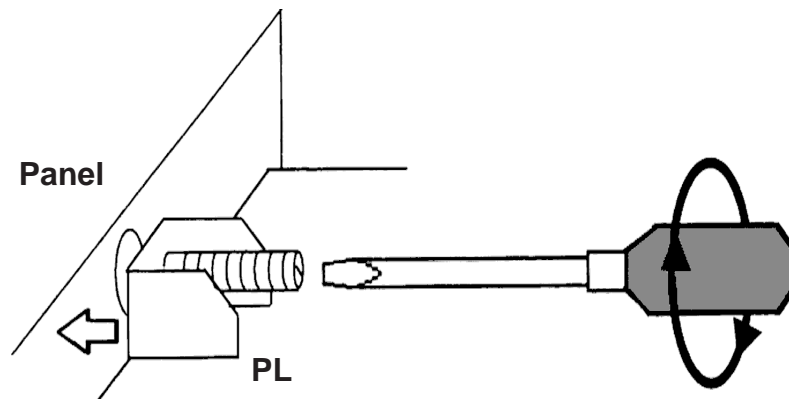

Excessive torque may damage the panel or bracket.

4-3 Wiring the PL

1 Connecting the Power Cord

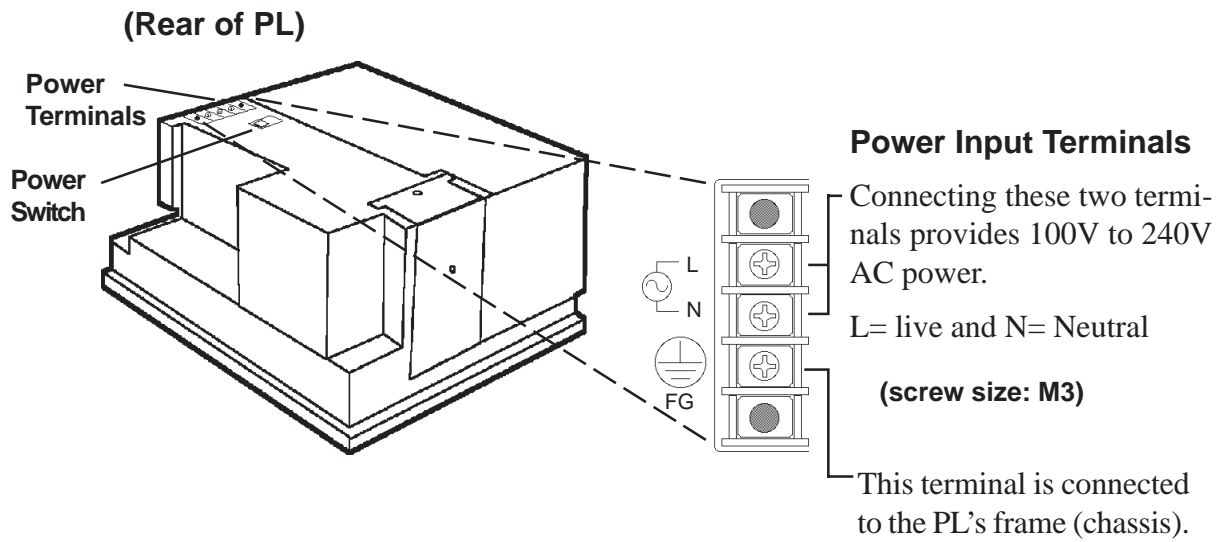

WARNING

- To prevent electric shocks, be sure to turn the PL OFF before connecting the power cord.
- To avoid the dangers of fire, electric hazards and equipment damage, be sure to use only the specified power supply voltage when operating the PL-6700.

Use the following steps when connecting the power cord to the PL's power terminals.

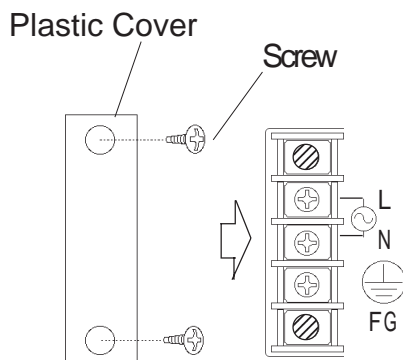

- 1) **Confirm that the power switch is turned OFF. Then, remove the power terminal's transparent plastic cover.**

Optional Units and Expansion Boards

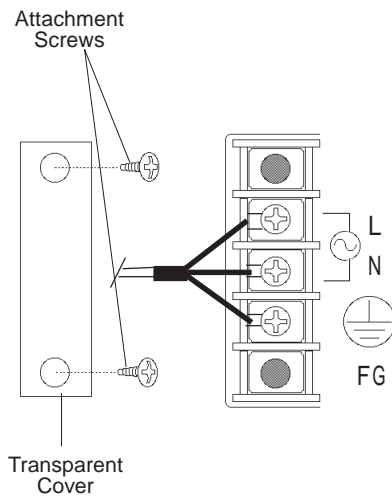
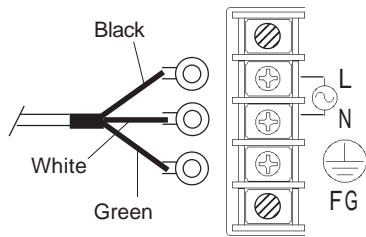

- 2) Loosen and remove the middle three screws from the terminal strip. Align the crimp terminals with each screw hole, and tighten the screws.



- Crimp Terminal Types : V1.25-3, by J.S.T. or equivalent (JIS standard part number : **RAV1.25-3**)
- Crimp terminals must be the same as shown below.

Max. 6.0 mm  ϕ 3.2 mm or larger



- The colors in the figure above are for the cable which came with the PL.
- This power cable is designed only for 100V use. Be sure to use a different cable when using other than 100V power.

- 3) Reattach the terminal strip's transparent cover.

2 Power Supply Cautions

When connecting power to the PL unit's AC power terminals, please be aware of the following:

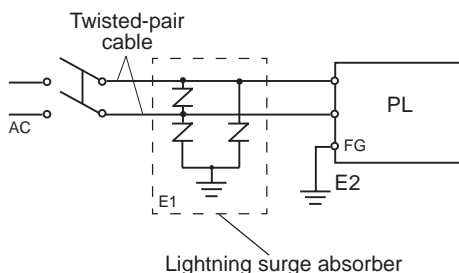
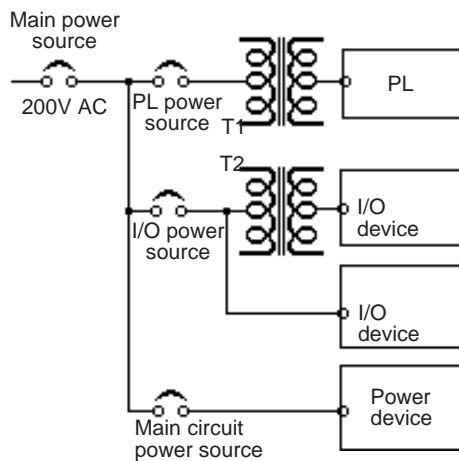
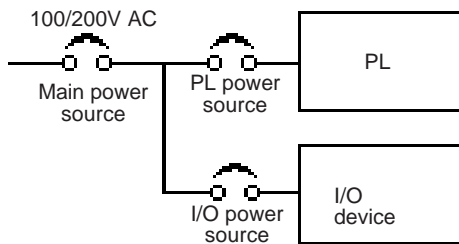
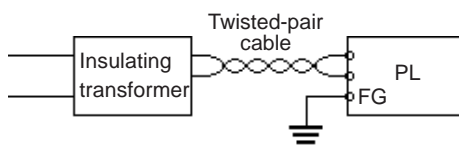
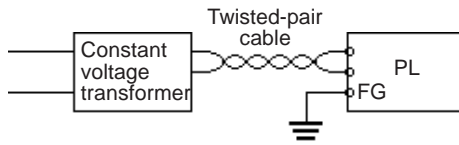

- If voltage fluctuations are expected to vary beyond the specified range, connect a constant voltage transformer.

 For information about the specified voltage, refer to “2-1 General Specifications”

- Use a low-noise power supply both between the lines and between the PL and its ground. If there is still excess noise, connect an insulating transformer (noise-prevention type) .

 Be sure any constant or insulating transformer used has a capacity of 200VA or more.

- Wire the power cords of the PL, I/O devices, and power supply devices separately.

- To improve noise immunity, it is recommended to attach a ferrite core to the power cord.
- Isolate the main circuit (high voltage, large current) line, I/O signal lines, and power cord, and do not bind or group them together.

- To prevent damage from lightning, connect a lightning surge absorber.

 • **Ground the lightning surge absorber (E1) and the PL (E2) separately.**

• **Select a lightning surge absorber which will not exceed the allowable circuit voltage, even when the voltage rises to the maximum.**

3 Grounding Cautions

(a) Dedicated Ground *1

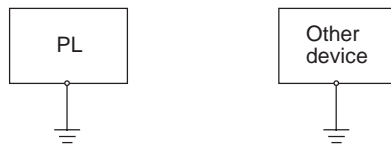

- Set up a dedicated ground when using the rear panel's FG terminal.

(b) Shared Ground - allowed *1

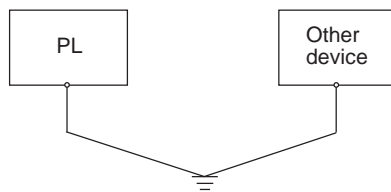

- If a dedicated ground is not possible, use a shared ground, as shown in figure (b).
- The grounding point must be as close to the PL as possible, and the grounding wires must be as short as possible. If the wires must be long, use thick, insulated wires and run them through conduits.

(c) Shared ground - not allowed

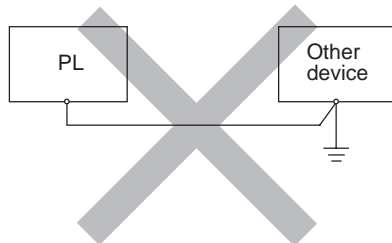

4 Cautions When Connecting I/O Signal Lines

- I/O signal lines must be wired separately from the power circuit cable.
- If the power circuit cable needs to be wired together with the input/output (I/O) signal lines for any reason, use shielded cables and ground one end of the shield to the PL's FG terminal.
- To improve noise immunity, it is recommended to attach a ferrite core to the power cord.

*1 Use a grounding resistance of less than 100 Ω and a 2mm² or thicker wire, or your country's applicable standard. For details, contact your local PL distributor.

MEMO

This page intentionally left blank.

Chapter 5

5-1 Setup Procedures

5-2 System Parameters

System Setup

This chapter explains how to enter the PL-6700's system settings, as well as the cautions required both before and during set up.

5-1 Setup Procedures



CAUTION! Normally, use only the factory (default) settings.



NOTE The following settings are those pre-set at the factory.

- 1) Connect the keyboard to the PL.
- 2) Turn the PL's power ON.
- 3) After the message "Press to Enter SETUP" appears, press the [DEL] key until the following screen appears.

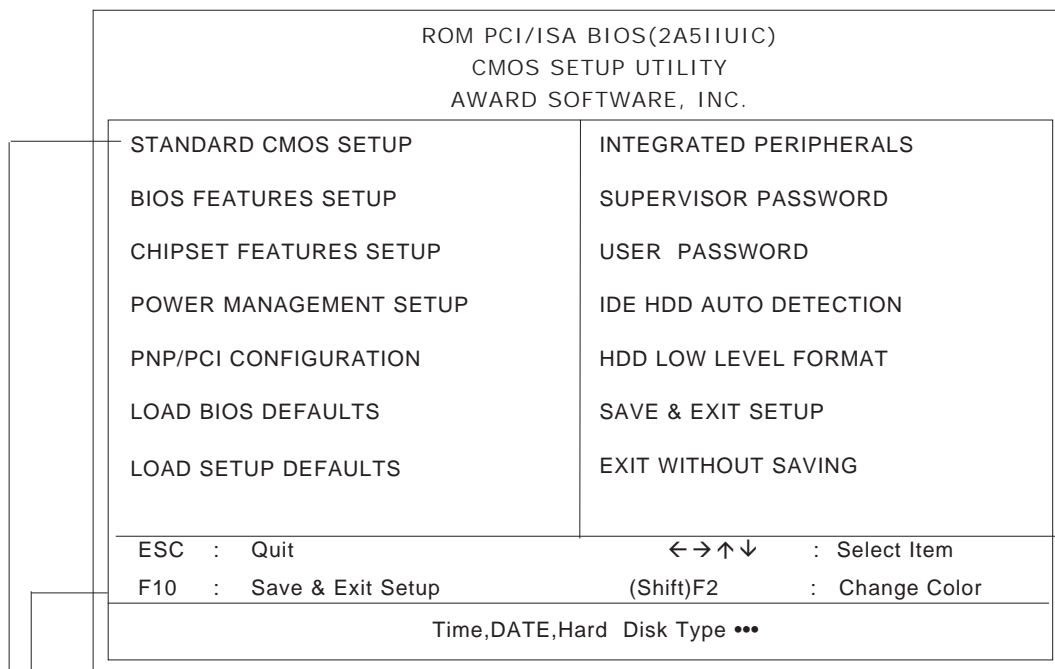

KEYBOARD ACTION KEYS

Provides a summary of the keyboard keys used to carry out the setup.

SYSTEM SETTING SELECTION AREA

Each of the titles (areas) listed here contains system setting items.

- 4) Use the arrow keys to move the cursor to the desired selection.

5-2 System Parameters

1 STANDARD CMOS SETUP

Selecting the STANDARD CMOS SETUP menu item produces the following screen.

```

ROM PCI/ISA BIOS(2A51IU1C)
  CMOS SETUP UTILITY
  AWARD SOFTWARE, INC.

Date (mm:dd:yy): Wed,Jul 2 1997

Time (hh:mm:ss): 14 : 50 : 3

HARD DISKS  TYPE SIZE CYLS HEAD PRECOMP  LANDZ  SECT0R  MODE
Primary Master :Auto  0   0   0       0       0       0       AUTO
Primary Slave  :Auto  0   0   0       0       0       0       AUTO

Drive A : 1.44M , 3.5 in.
Drive B : None
VGA Text Mode:Expansion
VGA Graphic Mode:Expansion
Floppy3 Mode Support:Disabled
LCD & CRT : Both
Halt On : All Errors

Base Memory :    640K
Extended Memory : 31744K
Other Memory :   384K
-----
Total Memory :  32768K

ESC  : Quit          ← → ↑ ↓ : Select Item          PU/PD/+/- : Modify
F1   : Help          (Shift)F2 : Change Color

```

Date/Time

This data sets the PL's internal time and date.

Hours :00 - 23
 Minutes :00 - 59
 Seconds :00 - 59

■ Primary Master

This data sets the ISE hard disk's parameters. When this setting is set to [AUTO], the hard disk's parameters are automatically read in. Also, if the "IDE HDD AUTO DETECTION" is in use, the value entered there is automatically set. The three options are [User],[Auto], or [None]. The [Auto] setting is factory set and recommended for most users.

Primary Slave

The three options are [User],[Auto], or [None]. The [Auto] setting is factory set and recommended for most users.

DriveA

This setting determines the format used by the PL's internal floppy disk drive.

The selection [1.44MB - 3.5in] is recommended. The other available settings are [720K - 3.5in], [1.2M - 5.25in], [360 - 5.25in], [2.88M - 3.5in.], or [None]. The[1.44M - 3.5in] selection is factory set and recommended for most users.

System Setup

DriveB

The selection [None] is recommended. The other available settings are [1.44MB - 3.5in], [720K - 3.5in], [1.2M - 5.25in], [360 - 5.25in], [2.88M - 3.5in.], or [None]. The [None] selection is factory set and recommended for most users.

Floppy 3 Mode Support

The possible selections include [Disabled],[DriveA],[DriveB]or[Both].The [Disabled] selection is factory set and recommended for most users.

LCD & CRT

This setting determines the type of display device used. The list of selections include [Both], [LCD] or [CRT]. The [Both] selection is factory set and recommended for most users.

- [Both]** : Displays on both the PL-6700's [LCD] and the external CRT.
- [LCD]** : Displays on the PL-6700's [LCD].
- [CRT]** : Displays on the CRT.

VGA Text Mode

Designates if the characters displayed in English Text Mode are displayed in expanded or normal form.The selections are [Expansion] or [Normal]. The [Expansion] selection is factory set and recommended for most users.



When the BIOS setup utility's Text Expansion feature is set to "Expansion", and the English DOS "50 Character Display Mode" is used, the screen's display will expand horizontally, not vertically.

VGA Graphics Mode

Designates if the display used in VGA graphics Mode shows screen data in the expanded or normal form. The selections are [Expansion] or [Normal]. The [Expansion] selection is factory set and recommended for most users.

Halt On

Designates the type of processing that will be performed when an error occurs during the Initial Start-Up's Self Test. The [All Errors] selection is factory set and recommended for most users.

- [All Errors]** : Displays all errors and stops the unit.
- [No Errors]** : Displays all errors and does not stop the unit.
- [All,But Keyboard]** : Displays all errors, except for those related to the keyboard, and stops the unit. If the User has no keyboard connected, please use this setting.
- [All,But Diskette]** : FDisplays all errors, except for those related to the disk drive (FDD), and stops the unit.
- [All,But Disk/Key]** : Displays all errors, except for those related to the disk drive (FDD) and keyboard, and then stops the unit.

2 BIOS FEATURES SETUP

Selecting the BIOS FEATURES SETUP menu item calls up the following screen.

ROM PCI/ISA BIOS(2A5LLU1C)		
BIOS FEATURES SETUP		
AWARD SOFTWARE, INC.		
Virus Warning	:Disabled	Video BIOS Shadow : Enabled
CPU Internal Cache	:Enabled	C8000-CBFFF Shadow : Disabled
External Cache	:Enabled	CC000-CFFFF Shadow : Disabled
Quick Power On Self Test	:Enabled	D0000-D3FFF Shadow : Disabled
Boot Sequence	:C,A	D4000-D7FFF Shadow : Disabled
Swap Floppy Drive	:Disabled	D8000-DBFFF Shadow : Disabled
Boot Up NumLock Status	:Off	DC000-DFFFF Shadow : Disabled
Gate A20 Option	:Fast	
Memory Parity Check	:Disabled	ESC :Quit ←→↑↓ :Select Item
Security Option	:Setup	F1 : Help PU/PD/+/- :Modify
PCI/VGA Palette Snoop	:Disabled	F5 : Old Values (Shift)F2 :Color
OS Select For DRAM > 64MB	:Non-OS2	F6 : Load BIOS Defaults
		F7 : Load Setup Defaults

■ Virus Warning

Designates whether a warning message appears when an error occurs during a write to the Hard Disk's Boot Sector. The two selections are [Disabled]or[Enabled]. The [Disabled] selection is factory set and recommended for most users.

■ CPU Internal Cache

Designates if the CPU's Internal Cache Memory is used or not. The two selections available are [Disabled]or[Enabled]. The [Enabled] selection is factory set and recommended for most users.

■ External Cache

Designates if the CPU's External Cache Memory (L2) is used or not. The two selections available are [Disabled]or [Enabled]. The [Enabled] selection is factory set and recommended for most users.

■ Quick Power On Self Test

Designates if a simplified Self Test is used after the power is turned ON. The two selections available are [Disabled]or[Enabled]. The [Enabled] selection is factory set and recommended for most users.

■ Boot Sequence

Designates the drive order used by the OS during start up. The possible selections are [C only], [A,C], [C,A], [C,CDROM,A] or [CDROM,C,A]. The [C,A] selection is factory set and recommended for most users.

System Setup

- **Swap Floppy Drive**

When two (2) floppy disk drives (FDD) are installed, setting this selection to [Enabled] will cause the order of the A and B drives to be swapped. The two selections available are [Disabled] or [Enabled]. The [Disabled] selection is factory set and recommended for most users.
- **Boot Up Numlock Status**

Designates the condition of the NumLock key at startup. The two selections are either [On] or [Off]. The [Off] selection is factory set and recommended for most users.
- **Gate A20 Option**

The two selections available are [Fast] or [Normal]. When [Normal] has been selected, Keyboard Control is used for Gate A20 control. When [Fast] is selected, the Chipset is used. The [Fast] selection is factory set and recommended for most users.
- **Memory Parity Check**

Designates if a Parity Check is used for Parity Memory. The two selections available are [Disabled] or [Enabled]. The [Disabled] selection is factory set and recommended for most users.
- **Security Option**

Designates the location of the Password Entry, [Setup], used during BIOS setup, or [System], which is used during BIOS setup and Startup. When the [Supervisor Password] or User Password] area's password has not been designated, this setting is disabled. The two selections available are [Disabled] or [Enabled]. The [Disabled] selection is factory set and recommended for most users.
- **PCI/VGA Palette Snoop**

When the PCI/VGA and the MPEG ISA/VESA VAG cards are both used, this setting is set to [Enabled]. In all other cases, this should be set to [Disabled]. The [Disabled] selection is factory set and recommended for most users.
- **OS Select For DRAM >64MB**

Select either [Non-OS2] or [OS2]. The [Non-OS2] selection is factory set and recommended for most users.
- **Video BIOS Shadow**

Designates whether Video BIOS ROM is expanded into RAM and used from there (C0000-C7FFF). The two selections available are [Disabled] or [Enabled]. The [Enabled] selection is factory set and recommended for most users.
- **C8000-CBFFF Shadow to DC000-DFFFF Shadow**

When the Expansion Board's ROM is placed in this area, this setting designates if the ROM expands into the RAM area. The two selections available are [Disabled] or [Enabled]. The [Disabled] selection is factory set and recommended for most users.

3 CHIPSET FEATURES SETUP

Selecting the CHIPSET FEATURES SETUP menu item calls up the following screen.

Since the CHIPSET FEATURES SETUP screen is a view only screen, no selections or input can be performed.

ROM PCI/ISA BIOS(2A51IU1C)	
CHIPSET FEATURES SETUP	
AWARD SOFTWARE, INC.	
Auto Configuration	: Disabled
L2 (WB) Tag Bit Length	: 8bits
SRAM Back-to-Back	: Enabled
NA# Enable	: Enabled
Starting Point of Paging	: 1T
Refresh Cycle Time (us)	: 15.6
RAS Pulse Width Refresh	: 6T
RAS Precharge Time	: 5T
RAS to CAS Delay	: 5T
CAS# Pulse Width(FP)	: 2T
CAS# Pulse Width(EDO)	: 1T
RAMW# AssertionTiming	: 3T
CAS Precharge Time(FP)	: 2T
CAS Precharge Time(EDO)	: 2T
Enhanced Memory Write	: Disabled
Read Prefetch memory RD	: Disabled
CPU to PCI Post Write	: 4T
CPU to PCI Burst Mem.WR	: Disabled
ISA Bus Clock Frequency	: PCICLK/4
ESC: Quit	←→↑↓ :Select Item
F1 : Help	PU/PD/+/- :Modify
F5 : Old Values (Shift)	F2 :Color
F6	: Load BIOS Defaults
F7	: Load Setup Defaults

4 POWER MANAGEMENT SETUP

Selecting the POWER MANAGEMENT SETUP menu item calls up the following screen.

ROM PCI/ISA BIOS(2A51IU1C)			
POWER MANAGEMENT SETUP			
AWARD SOFTWARE, INC.			
Power Management	: Disabled	HDD Ports Activity	: Enabled
PM Control by APM	: Yes	VGA Activity	: Disabled
Video Off Option	: Always on	IRQ3 (COM 2)	: Enabled
Video Off method	: DPMS Supported	IRQ4 (COM 1)	: Enabled
		IRQ5 (LPT 2)	: Enabled
Doze Speed (div by)	: 2	IRQ6 (Floppy Disk)	: Enabled
Stdby Speed (div by)	: 3	IRQ7 (LPT 1)	: Enabled
Suspend Option	: Static Suspend	IRQ3 (RTC Alarm)	: Disabled
MODEM Use IRQ	: 3	IRQ9 (IRQ2 Redir)	: Enabled
FAN Control	: Disabled	IRQ10 (COM 4)	: Enabled
PM Timers		IRQ11 (COM 3)	: Enabled
HDD Off After	: Disabled	IRQ12 (PS/2 Mouse)	: Enabled
Doze Mode	: Disabled	IRQ13 (Coprocessor)	: Enabled
Standby Mode	: Disabled	IRQ14 (Hard Disk)	: Enabled
Suspend Mode	: Disabled	IRQ15 (Reserved)	: Enabled
PM Events		ESC: Quit	← → ↑ ↓ :Select Item
COM Ports Activity	: Enabled	F1 : Help	PU/PD/+/- :Modify
LPT Ports Activity	: Enabled	F5 : Old Values (Shift)	F2 :Color
		F6 : Load BIOS Defaults	
		F7 : Load Setup Defaults	

Power Management

You can choose from four power management options. These are [User Defined],[Disabled], [Min Saving] or [Max Saving]. The [Disabled] selection is factory set and recommended for most users.

PM Control by APM

Designates if the power management is controlled by the APM. The two selections available are [Yes]or [No]. The [Yes] selection is factory set and recommended for most users.

Video Off Option

Turns the PL-6700's display OFF. The selections include [Always on], [Suspend Off], [Susp,Stby Off] and [All Modes Off].

Video Off method

When Auto Configuration [Enabled] has been selected, this selection cannot be used.

Doze Speed (div by)

Selections for this feature include [1],[2],[3],[4],[5],[6],[7]or[8]. The [2] selection is factory set and recommended for most users.

Stdby Speed (div by)

Selections for this feature include [1],[2],[3],[4],[5],[6],[7]or[8]. The [3] selection is factory set and recommended for most users.

Suspend Option

When Auto Configuration Enable has been selected, this selection cannot be used. The [Static Suspend] selection is factory set and recommended for most users.

MODEM Use IRQ

Selections for this feature include [1],[2],[3],[4],[5],[6],[7]or[8]. The [3] selection is factory set and recommended for most users.

FAN Control (CPU Fan)

The two selections available are [Disabled]or [Enabled]. The [Disabled] selection is factory set and recommended for most users.

HDD Off After

Designates the period of time to elapse before the HDD's motor turns itself OFF. The selections include [1Min] [15Min], [1-15Min]or[Disabled].The [Disabled] selection is factory set and recommended for most users.

Doze Mode

Only after Auto Configuration has been set to [User Define] can the Doze Mode be used. The [Disabled] selection is factory set and recommended for most users.

Standby Mode

Only after Auto Configuration has been set to [User Define] can the Standby Mode be used. The [Disabled] selection is factory set and recommended for most users.

Suspend Mode

Only after Auto Configuration has been set to [User Define] can the Suspend Mode be used. The [Disabled] selection is factory set and recommended for most users.

COM Ports Activity

Designates if the COM Port is monitored or not. The two selections available are [Disabled]or [Enabled]. The [Enabled] selection is factory set and recommended for most users.

LPT Ports Activity

Designates if the LPT (Parallel) Port is monitored or not. The two selections available are [Disabled]or [Enabled]. The [Enabled] selection is factory set and recommended for most users.

HDD Ports Activity

Designates if the HDD (Hard Disk) Port is monitored or not. The two selections available are [Disabled]or [Enabled]. The [Enabled] selection is factory set and recommended for most users.

VGA Activity

Designates if the VGA Port is monitored or not. The two selections available are [Disabled]or [Enabled]. The [Disabled] selection is factory set and recommended for most users.

IRQ3-IRQ15

Designate if the COM Port is monitored or not. The two selections available are [Disabled]or [Enabled].

5 PNP/PCI CONFIGURATION SETUP

Selecting the PNP/PCI CONFIGURATION SETUP menu item displays the following screen.

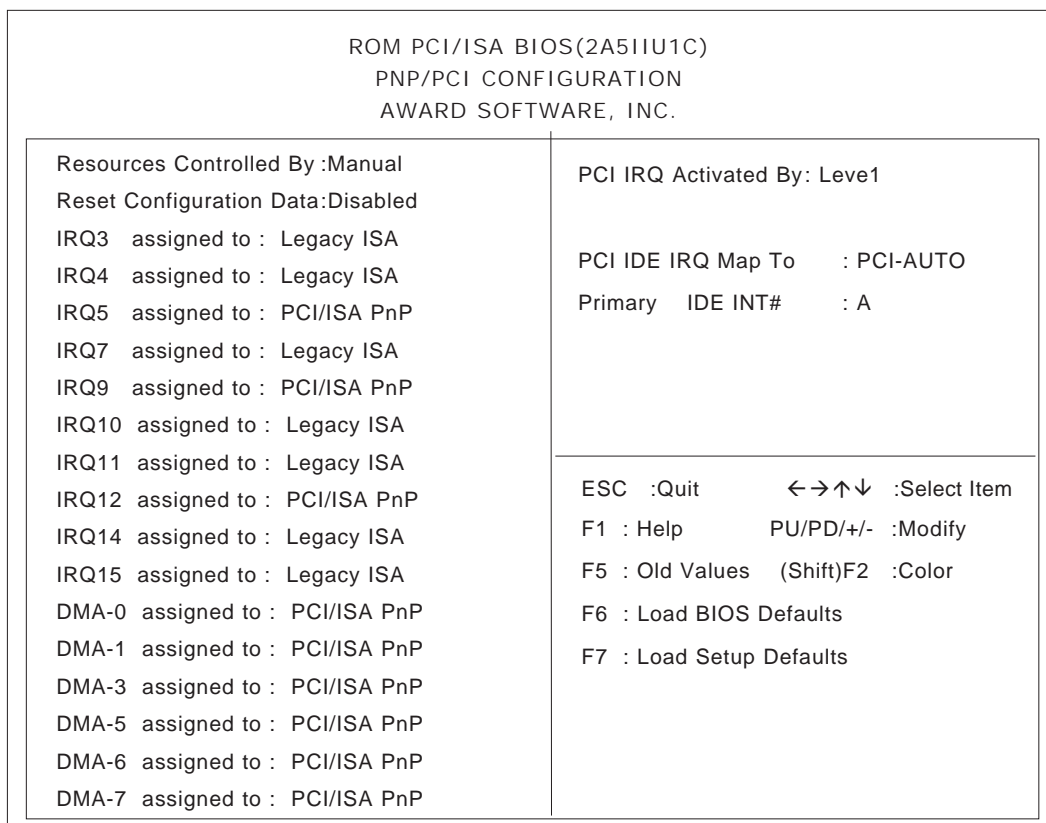

Resources Controlled By

Designates whether the allocation of I/O Port, IRQ and DMA resources is done automatically or manually. The two selections available are [Manual] or [Auto]. The [Manual] selection is factory set and recommended for most users.

Reset Configuration Data

Designates whether all current setting data should be erased or not. The two selections available are [Disabled] or [Enabled]. The [Disabled] selection is factory set and recommended for most users.

IRQ-3 assigned to - IRQ-15 assigned to

Only after the "Resources Controlled By" setting is set to [Manual] can the following IRQ-3 assigned to - IRQ-15 assigned to settings be changed. These settings are used for the [PCI/ISA PnP] and [Legacy ISA] items.

[PCI/ISA PnP] :Used for PCI or ISA's PnP Card

[Legacy ISA] :Used for ISA Cards that do not comply with PnP

	INITIAL SETTING		INITIAL SETTING
IRQ-3 assigned to	Legacy ISA	IRQ-10 assigned to	Legacy ISA
IRQ-4 assigned to	Legacy ISA	IRQ-11 assigned to	Legacy ISA
IRQ-5 assigned to	PCI/ISA PnP	IRQ-12 assigned to	PCI/ISA PnP
IRQ-7 assigned to	Legacy ISA	IRQ-14 assigned to	Legacy ISA
IRQ-9 assigned to	PCI/ISA PnP	IRQ-15 assigned to	Legacy ISA

DMA-0 assigned to - DMA-7 assigned to

Only after the "Resources Controlled By" setting is set to [Manual] can the following DMA-0 assigned to - DMA-7 assigned to settings be changed. These settings are used for the [PCI/ISA PnP] and [Legacy ISA] items.

[PCI/ISA PnP] : Used for PCI or ISA's PnP Card

[Legacy ISA] : Used for ISA Cards that do not comply with PnP

	INITIAL SETTING		INITIAL SETTING
DMA-0 assigned to	PCI/ISA PnP	DMA-5 assigned to	PCI/ISA PnP
DMA-1 assigned to	PCI/ISA PnP	DMA-6 assigned to	PCI/ISA PnP
DMA-3 assigned to	PCI/ISA PnP	DMA-7 assigned to	PCI/ISA PnP

IRQ-3 assigned to - IRQ-15 assigned to

Only after the "Resources Controlled By" setting is set to [Manual] can the following IRQ-3 assigned to - IRQ-15 assigned to settings be changed. These settings are used for the [PCI/ISA PnP] and [Legacy ISA] items.

[PCI/ISA PnP] : Used for PCI or ISA's PnP Card

[Legacy ISA] : Used for ISA Cards that do not comply with PnP

PCI IRQ Activated By

Designates allocation method used for the PCI slots. The two selections available are [Level] or [Edge]. The [Level] selection is factory set and recommended for most users.

PCI IDE IRQ Map To

Designates if the CPU board IDE controller's allocation is performed automatically by the PCI, or fixed as ISA. The two selections available are [PCI-AUTO] or [ISA]. The [PCI-AUTO] selection is factory set and recommended for most users.

Primary IDE INT#

Only after selecting the "PCI IDE IRQ Map To" menu item's [PCI-AUTO] can the Primary IDE INT# setting be used. These settings can be [A], [B], [C] or [D].

6 INTEGRATED PERIPHERALS SETUP

Selecting INTEGRATED PERIPHERALS SETUP menu item displays the following screen.

ROM PCI/ISA BIOS(2A51IU1C)			
INTEGRATED PERIPHERALS			
AWARD SOFTWARE, INC.			
Internal PCI/IDE	: Primary	Com 3 & Com 4 Mode	: Enable
IDE Primary Master PIO	: Auto	Com 3 Port Resource	: 3E8/IRQ11
IDE Primary Slave PIO	: Auto	Com 4 Port Resource	: 2E8/IRQ10
IDE Burst Mode	: Disabled		
IDE Date Port Post Write	: Enabled		
IDE HDD Block Mode	: Enabled		
Onboard FDC Controller	: Enabled		
Onboard Serial Port1	: 3F8/IRQ4	ESC : Quit	←→↑↓ :Select Item
Onboard Serial Port2	: 2F8/IRQ3	F1 : Help	PU/PD/+/- :Modify
UART2 Mode	: Normal	F5 : Old Values (Shift)F2	:Color
Onboard Parallel Port	: 3BC/IRQ7	F6 : Load BIOS Defaults	
Parallel Port Mode	: Compatible	F7 : Load Setup Defaults	

Internal PCI/IDE

Designates the internal IDE port's setting. The two selections available are [Disabled] or [Primary]. The [Primary] selection is factory set and recommended for most users.

IDE Primary Master PIO

Designates the Master Drive's Operation Mode. Only after the "Internal PCI/IDE" has been set to [Primary] can these IDE Primary Master PIO settings be entered. The two selections available are [Auto] or [Mode0] ->[Mode4]. The [Auto] selection is factory set and recommended for most users.

IDE Primary Slave PIO

Designates the Slave Drive's Operation Mode. Only after the "Internal PCI/IDE" has been set to [Primary] can these IDE Primary Slave PIO settings be entered. The two selections available are [Auto] or [Mode0] [Mode4]. The [Auto] selection is factory set and recommended for most users.

IDE Burst Mode

Only after the Internal PCI/IDE has been set to [Primary] can these IDE Primary Slave PIO settings be entered. The two selections available are [Disabled] or [Enabled]. The [Disabled] selection is factory set and recommended for most users.

IDE Date Port Post Write

The two selections available are [Disabled] or [Enabled]. The [Enabled] selection is factory set and recommended for most users.

IDE HDD Block Mode

Designates the Hard disk's Block Operation Mode. The two selections available are [Disabled] or [Enabled]. The [Enabled] selection is factory set and recommended for most users.

Onboard FDC Controller

Designates whether the PL's FDD(Floppy Disk Drive) controller is used or not. The two selections available are [Disabled] or [Enabled]. The [Enabled] selection is factory set and recommended for most users.

Onboard Serial Port1

Designates the PL's Serial 1(COM1) port address setting. The selections include [Disabled], [2F8/IRQ3] or [3F8/IRQ4]. The [3F8/IRQ4] selection is factory set and recommended for most users.

Onboard Serial Port2

Designates the PL's Serial 2(COM2) port address setting. The selections include [Disabled], [2F8/IRQ3] or [3F8/IRQ4]. The [2F8/IRQ3] selection is factory set and recommended for most users.

UART2 Mode

Only when the Onboard Serial Port2 is set to [Disabled] can the UART2 Mode be used. The selections include [Normal], [Sharp IR], [IrDA SIR], [IrDA MIR] or [IrDA FIR]. The [Normal] selection is factory set and recommended for most users.

Onboard Parallel Port

Selects the PL's Parallel Port Address. Normally, use [3BC/IRQ7]. The selections include [Disabled], [3BC/IRQ7], [378/IRQ7] or [278/IRQ5]. When any selection other than [Disabled] is used, [EPP], [ECP], [Compatible] or [Extended] must also be selected. Also, if [EPP] has been selected, either Ver [1.7] or Ver [1.9] must be selected. Last, if [ECP] has been selected, either ECP Mode use DMA's [1] or [3] must also be selected.

Parallel Port Mode

Here, the parallel port's single-direction ([Normal]) or dual-direction ([EPP], [ECP] or [ECP->EPP]) modes can be selected. The selections include [Compatible], [Extended] or [ECP]. Normally, [Compatible] is used, however when a selection other than [Compatible] is used, the [ECP mode Use DMA] selection must also be used.

ECP Mode Use DMA

Designates which DMA setting is used for the ECP mode. The two selections available are [1] or [3]. The [1] selection is factory set and recommended for most users.

Com 3 & Com 4 Mode

Designates whether the PL's COM3 and COM4 (Touch Panel) are used or not. The two selections available are [Disabled] or [Enabled].

Com 3 Port Resource

Only when the "Com 3 & Com 4 Mode" is set to [Enabled] will this selection appear. The [3E8/IRQ11] selection is factory set and recommended for users.

Com 4 Port Resource

Only when the Com 3 & Com 4 Mode is set to [Enabled] will this selection appear. The [2E8/IRQ10] selection is factory set and recommended for most users.

7 IDE HDD AUTO DETECTION SETUP

Selecting the IDE HDD AUTO DETECTION menu item produces the following screen.

Provides automatic detection of any hard disk connected to the IDE. Normally unused.

ROM PCI/ISA BIOS(2A511U1C)
CMOS SETUP UTILITY
AWARD SOFTWARE, INC.

HARD DISKS TYPE SIZE CYLS HEAD PRECOMP LANDZ SECTOR MODE
Primary Master :

Select Primary Master Option(N=Skip) : N

OPTIONS	SIZE	CYLS	HEAD	PRECOMP	LANDZ	SECTOR	MODE
2(Y)	1630	790	64	0	3161	63	LBA
1	1632	3162	16	65535	3161	63	NORMAL
3	1632	1581	32	65535	3161	63	LARGE

Note : Some OS (like SCO-UNIX) must use "NORMAL" for Installation

ESC:Skip

8 HDD LOW LEVEL FORMAT SETUP

Selecting the HDD LOW LEVEL FORMAT menu item produces the following screen.

Performs low-level formatting of the hard disk. Normally unused.

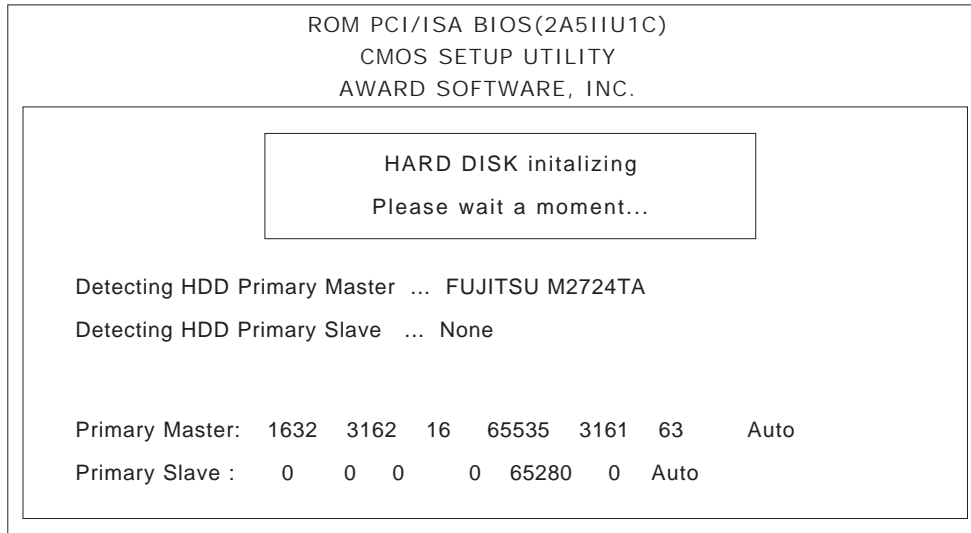

6 Bundled Software

The Digital Electronics Corporation has prepared the following additional program files, which are not supported by the standard version of Windows® 95 or Windows® NT.

This chapter describes the contents of the PL's additional program files, hereafter referred to as "PL Software".

6-1 PL-6700 Floppy Disk File List



If the User installs an OS (operating system) other than that written here, the correct operation of the following programs cannot be guaranteed.

File Name	Contents
README95e.TXT	This file is for Windows 95 users and contains the latest detailed information about the PL's additional software programs. Please be sure to read this file before operating any of the PL's additional software.
READMEnte.txt	This file is for Windows NT users and contains the latest detailed information about the PL's additional software programs. Please be sure to read this file before operating any of the PL's additional software.

The following additional program files are designed to run on both the Windows 95 and Windows NT operating systems.

File Name	Contents
DISP.EXE	This program is used to turn the PL's display ON or OFF. (includes turning backlight OFF)
FANALARM.EXE	Used to detect the CPU's cooler fan alarm.
BLSAVER.SCR	This screen saver program is used to turn the PL's backlight OFF.
PL67API.DLL	This DLL is used by the DISP, FANALARM, and BLSAVER programs. Both the Windows 95 and Windows NT versions of this file are included.
PL67DRV.SYS	This file is the device driver used by the PL67API.DLL, specifically for the Windows NT OS.

MEMO

This page intentionally left blank.

Maintenance and Inspection

This chapter describes how to properly maintain your PL unit.

7-1 Cleaning the Display

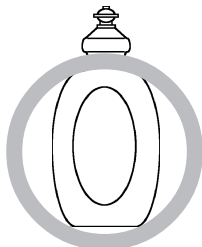

Neutral detergent

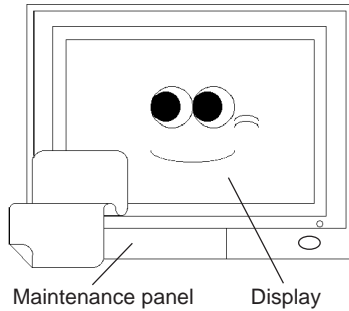

Maintenance panel Display

When the display surface or frame become dirty, use a soft cloth moistened with neutral detergent to wipe away any dust or stains.

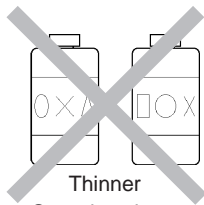

Thinner
Organic solvent
Strong acid

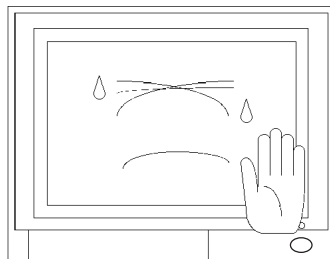

Do not clean the unit with thinner, organic solvents, or strong acids.

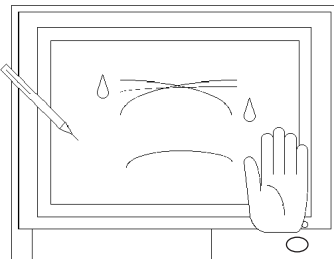

Do not use sharp or hard objects, such as a mechanical pencil or screwdriver, to push on the display. This could damage the unit.

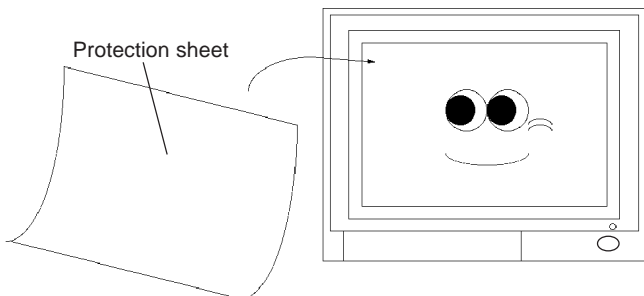

Protection sheet

Use the screen protection sheet when using the PL in extremely dirty or dusty areas.

■ About the Moisture Resistant Gasket

The moisture resistant gasket protects the GP and improves its water resistance. For instructions on installing the GP's gasket,

Reference Chapter 3.1 "Installation and Wiring"



- **A gasket which has been used for a long period of time may have scratches or dirt on it, and could have lost much of its water resistance. Be sure to change the gasket periodically (or when scratches or dirt become visible).**

7-2 Filter Cleaning

Since excessive dirt and dust in the filter of the PL-6700's cooling fan can potentially affect the performance of the unit, regular inspection and cleaning of the filter is strongly recommended.

Cleaning the PL-6700 cooling unit's filter:

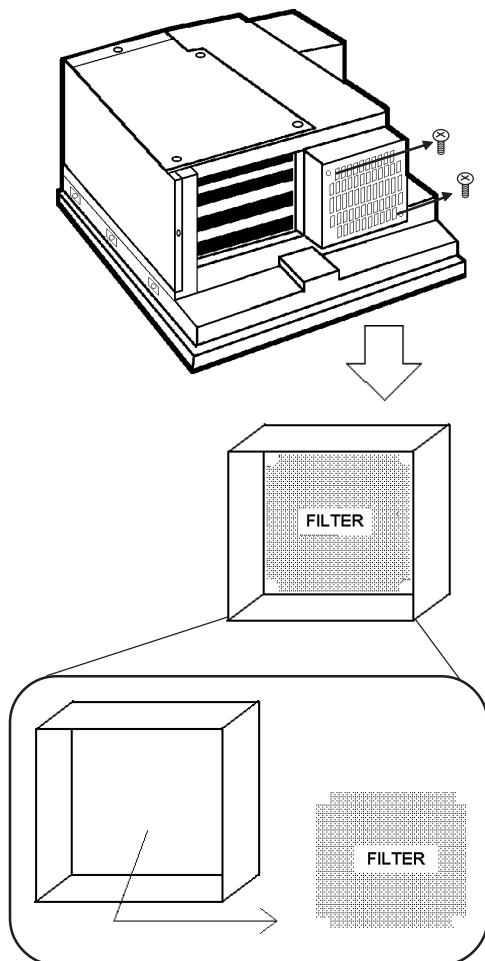

- 1) Remove the cooling fan cover's two (2) attachment screws.



Be sure to not drop the filter after removing the cover.

- 2) Remove the filter from the fan cover.

Maintenance and Inspection

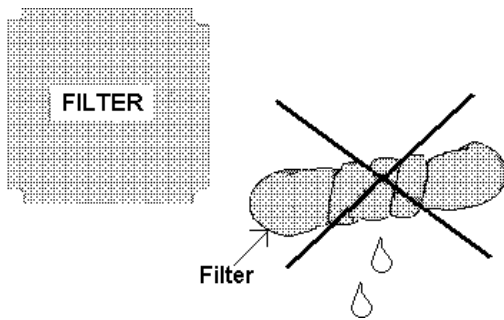

3) Clean the filter completely.

If stubborn dirt or stains are present, wash the filter with a neutral detergent.



- **Be sure the filter is completely dry before reattaching the filter to the fan cover.**
- **Do not wring the filter to dry it. Allow it to air dry.**

4) After reattaching the filter to the fan cover, reattach the filter cover to the cooling unit with the two cover attachment screws.

7-3 Periodic Maintenance Check Points

Check the PL periodically to ensure it is in good working condition.

- Ambient Environment
 - Is the ambient temperature within the specified range?
5 to 40°C for the PL-6700T and PL-6700S
 - Is the ambient humidity within the specified range (30 to 85 %RH) ?
 - Is the atmosphere free of corrosive gas ?
- Electrical Specifications
 - Is the voltage adequate (85 to 132 V AC, 50/60 Hz) ?
(170 to 260V AC, 50/60 Hz) ?
- Installation Conditions
 - Is the connection cable firmly connected (not loose) ?
 - Are any bolts or screws loose ?
 - Are there any flaws or tears in the moisture resistant packing ?
- Display Conditions
 - Is the display bright enough ?



When the PL's backlight needs to be replaced, please contact your nearest authorized service center for prompt service.

MEMO

Appendix

Hardware Configuration

1. Hardware Configuration
2. Serial Communications
3. Printer Cable Connections
4. BIOS Lists

1 Hardware Configuration

1. I/O Mapping

Address	AT system device	System-specific device
0000H - 001FH	DMA controller (8237)	
0020H - 003FH	Interrupt controller (8259A)	
0040H - 005FH	System timer (8254)	
0060H - 006FH	Keyboard (H8/3332)	
0070H - 007FH	Real-time clock, NMI mask	
0080H - 009FH	DMA bank register	
00A0H - 00BFH	Interrupt controller (8259A)	
00C0H - 00DFH	DMA controller 2 (8237)	
00F0H - 00FFH	Numeric data processor	
016CH - 016FH	Used by main board	016EH FAN ALARM
01F0H - 01FFH	Hard disk (IDE)	
0200H - 0207H	Game I/O *1	
02E8H - 02EFH	Serial port 4 (COM4) : Touch panel	Touch panel
02F8H - 02FFH	Serial port 2 (COM2) : General Use	or, used for IrDA
03B0H - 03BBH	Video controller (VGA)	
03BCH - 03BFH	Parallel port 1 (LPT1) : Printer	
03C0H - 03DFH	Video controller (VGA)	
03E8H - 03EFH	Serial port 3 (COM3): General Use	
03F0H - 03F7H	Floppy disk controller	
03F8H - 03FFH	Serial port 1 (COM1) :General Use	

*1 The game I/O is not used by the PL system, but is normally reserved.

<Extended I/O Bit Mapping>

Address #16EH is used by the PL system: do not assign it to other devices.

Bit7	Bit6	Bit5	Bit4	Bit3	Bit2	Bit1	Bit0
Sw4	Sw3	Sw2	Sw1			CPU Fan	Power Fan

Sw1 to Sw4: Circuit board switch (SW)'s lead.

CPU Fan: H = normal, L = Fan alarm

Power Fan: H = Fan alarm, L = normal

2. Memory Mapping

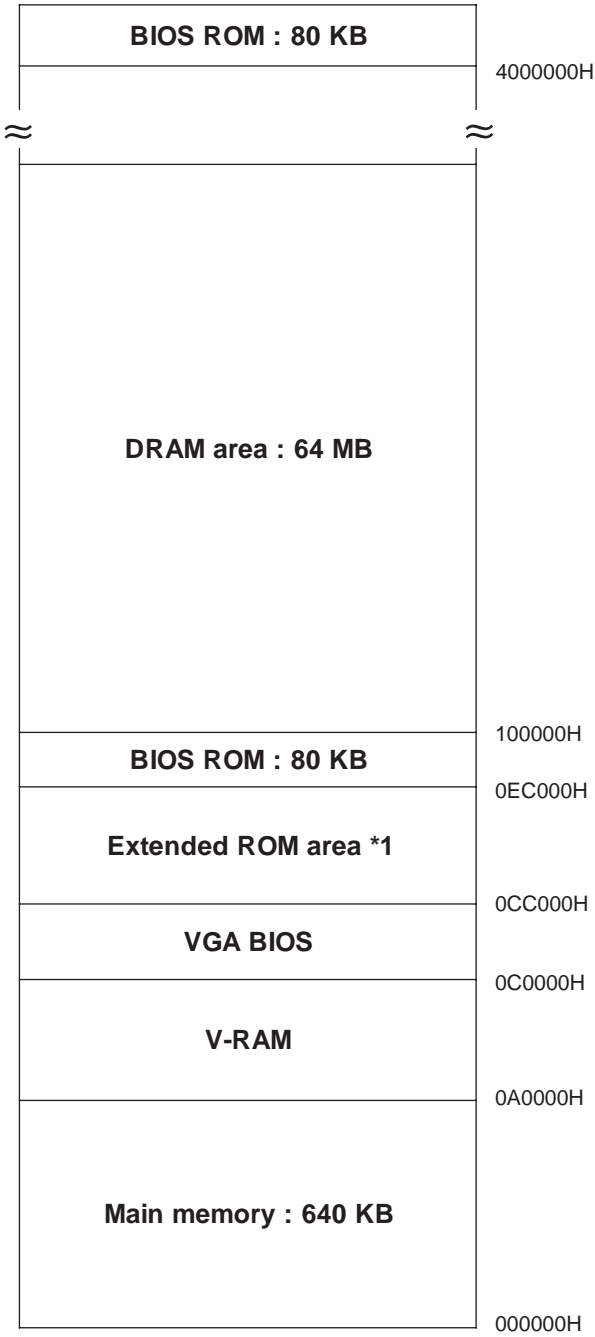

**1 This area is reserved for extended boards.*

3. IRQ Mapping

■ Hardware Interruption List

	Description
NMI	Parity error or I/O channel check
IRQ 0	Timer (in the chipset)
IRQ 1	Keyboard
IRQ 2	Cascade from controller 2
IRQ 3	Serial port 2 (COM2) : General Use port
IRQ 4	Serial port 1 (COM1) : General Use port
IRQ 5	Available to User
IRQ 6	Floppy disk controller
IRQ 7	Parallel port 1 (LPT1) : Printer port
IRQ 8	Real time clock
IRQ 9	Video controller (VGA) *1
IRQ 10	Serial port 4 (COM4) : Touch panel
IRQ 11	Serial port 3 (COM3) : General Use Port
IRQ 12	PS/2 mouse
IRQ 13	Numeric data processor
IRQ 14	Hard disk (IDE)
IRQ 15	Available to User

■ DMA Channel List

	Description	
DMA 0		For 8-bit transmission
DMA 1		
DMA 2	Floppy disk controller	
DMA 3		
DMA 4	Cascade to controller 1	For 16-bit transmission
DMA 5		
DMA 6		
DMA 7		

*1 IRQ 9 is not used by the PL, but reserved as standard.

2 Serial Communication

This section explains how to perform serial communications with the PL.

■ RS-232C (COM1/COM2/COM3) Cable Connections

<Example 1>

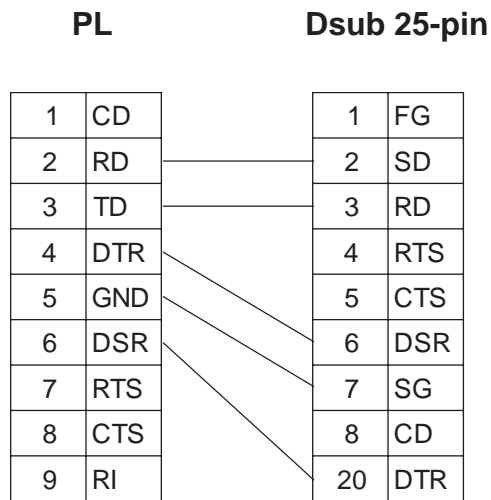

<Example 2>

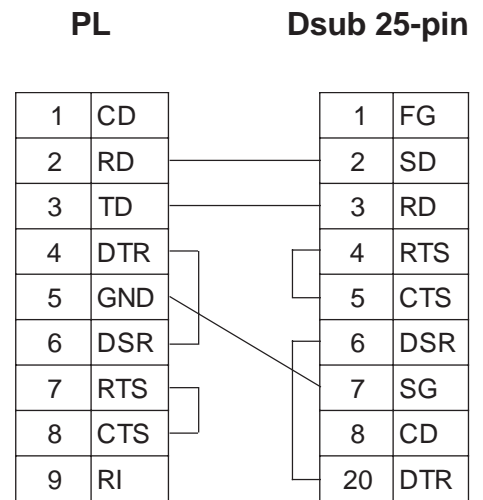

3 Printer Cable Connections

Below is an example of how to connect a printer to the PL.

Example: Connection to a printer with Centronics port

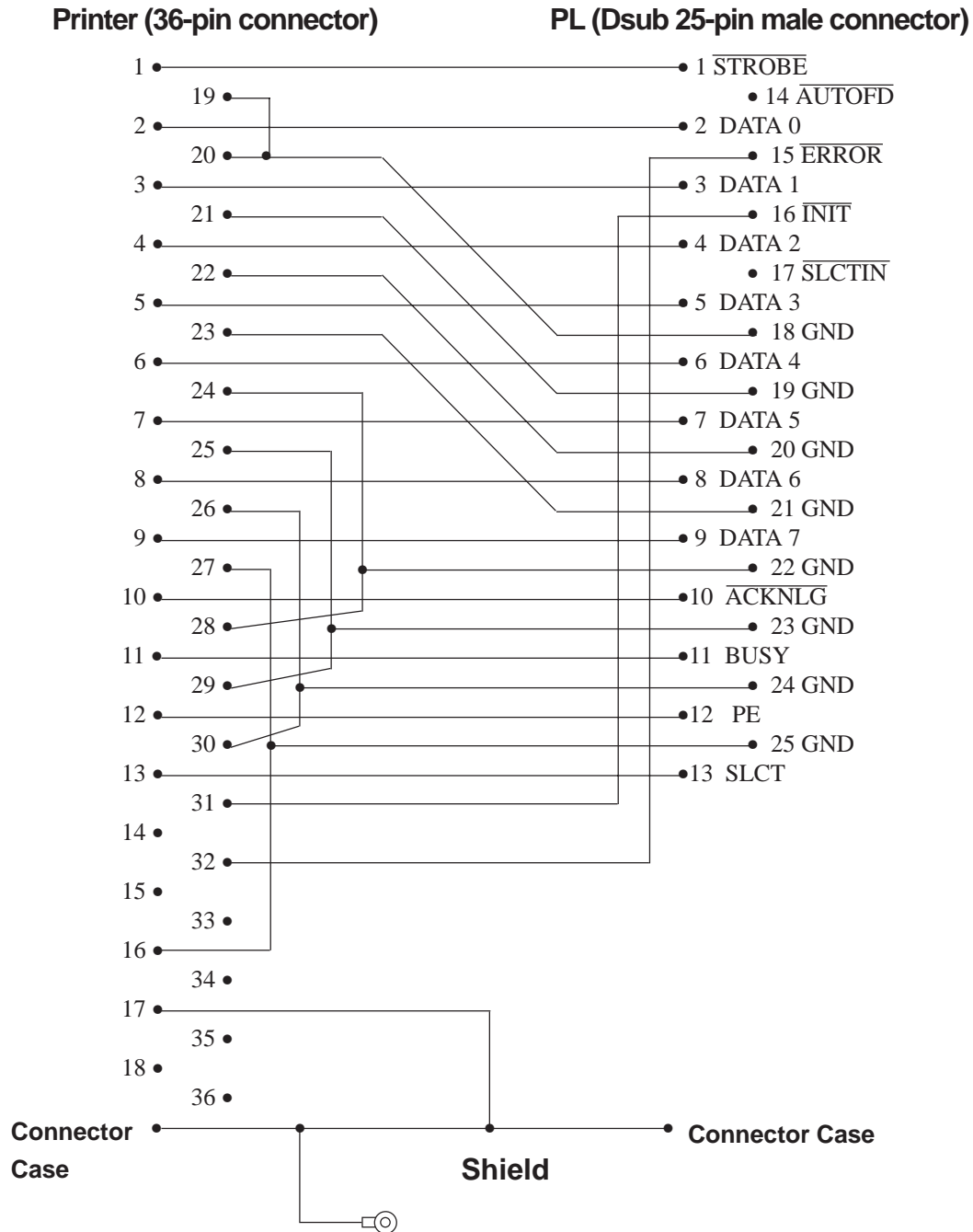

4 BIOS Lists

■ INT 5h Display Hard Copy

Operation	Input	Output
Screen hard copy		0050:0000h Print-screen flag 0: Hard copy function unused or completed successfully 1: Now printing -1: Error

■ INT 10h Video BIOS

Operation	Input	Output
Setting video mode	AH = 00h AL = Value of selected mode (Bits 0 ~ 6), Video RAM clear(Bit 7)	
Setting cursor shape	AH = 01h CH = Cursor start position and display CL = Cursor end position	
Setting cursor position	AH = 02h BH = Page No. DH = Value of specified line DL = Value of specified column	
Reading cursor position	AH = 03h BH = Page No.	CH = Cursor start position and display CL = Cursor end position DH = Current cursor line position DL = Current cursor column position
Reading light pen position	AH = 04h	AH = 0: Light pen switch is off. = 1: Light pen switch is on. BX = X coordinate (0 - 319, 639) CH = Y coordinate (0 - 199) CX = Y coordinate in new graphic mode (0, XXX) DH = Light pen line position in character units DL = Light pen column position in character units
Switching active page	AH = 05h AL = Page No.	
Scrolling up	AH = 06h AL = Number of lines to scroll up BH = Attribute of line to clear CH = Highest line in scroll up range CL = Farthest left column in scroll up range DH = Lowest line in scroll up range DL = Farthest right column in scroll up range	
Scrolling down	AH = 07h AL = Number of lines to scroll down BH = Attribute of line to clear CH = Highest line in scroll down range CL = Farthest left column in scroll down range DH = Lowest line in scroll down range DL = Farthest right column in scroll down range	

Operation	Input	Output
Reading character/attribute at cursor position	AH = 08h BH = Page No.	AL = Character code AH = Attribute (In text mode)
Writing character/attribute at cursor position	AH = 09h AL = Character code BH = Page No. BL = Attribute CX = Number of characters to output	
Writing character at cursor position	AH = 0Ah AL = Character code BH = Page No. BL = Attribute (Effective only in graphic mode) CX = Number of characters to output	
Setting color pallet		
Setting overscan, background color, and display color brightness	AH = 0Bh BH = 00h BL = Color code	
Setting color group	AH = 0Bh BH = 01h BL = Color group	
Writing point in graphic mode	AH = 0Ch AL = Attribute BH = Page No. CX = X coordinate DX = Y coordinate	
Reading point in graphic mode	AH = 0Dh BH = Page No. CX = X coordinate DX = Y coordinate	AL = Attribute
Writing character/attribute at cursor position and move cursor	AH = 0Eh AL = Character code BL = Attribute (Effective only in graphic mode)	
Reading video data	AH = 0Fh	AH = Number of single lines AL = Video mode BH = Active page No.
Setting pallet register		
Setting pallet register	AH = 10h AL = 00h BH = Pallet code BL = Pallet register No.	
Setting overscan register	AH = 10h AL = 01h BH = Pallet code	
Setting pallet register and overscan register	AH = 10h AL = 02h ES:DX= 17-byte data address	
Setting attribute code intensity/brink	AH = 10h AL = 03h BH = 00h: Set attribute bit 7 to intensity function. = 01: Set attribute bit 7 to blink function.	
Reading basic pallet register	AH = 10h AL = 07h BL = Basic pallet register to read (0 - 15)	BH = Value read

Operation	Input	Output
Setting pallet register		
Reading overscan register	AH = 10h AL = 08h	BH = Value read
Reading basic pallet register and overscan register	AH = 10h AL = 09h ES:DX = 17-byte buffer in which return value is located	
Setting expansion pallet register	AH = 10h AL = 10h BX = Selected expansion pallet register DH = Red value CH = Green value CL = Blue value	
Setting block in expansion pallet register	AH = 10h AL = 10h ES:DX = Color value table BX = First expansion pallet register to set CX = Number of blocks set in expansion pallet registers	
Selecting pallet page mode	AH = 10h AL = 12h BL = 00h BH = Pallet page mode = 00h: 4-pallet page mode = 01h: 16-pallet page mode	
Selecting pallet page	AH = 10h AL = 13h BL = 01h BH = Expansion pallet page No.	
Reading expansion pallet register	AH = 10h AL = 15h BX = Expansion pallet register to read	
Reading block in expansion pallet register	AH = 10h AL = 17h ES:DX = Buffer address of value to read BX = Expansion pallet address No. where to start reading CX = Number of registers to read	Buffer selected in ES:DX
Reading pallet page	AH = 10h AL = 17h	Current pallet page BL = mode = 0: 4-pallet page mode = 1: 16-pallet page mode BH = Current expansion pallet page mode
Gray scale conversion	AH = 10h AL = 1Bh BX = First expansion pallet register CX = Number of expansion pallet registers to convert	
Font registration		
Font registration of user-defined character	AH = 11h AL = 00h BH = Number of vertical bits in character BL = Character generator bank No. CX = Number of characters to register DX = First character code to register ES:BP = Top address in user-defined table	

Operation	Input	Output
Font registration		
8 x 14 dot font registration (PC character set, inside video BIOS ROM)	AH = 11h AL = 01h BL = Character generator bank No.	
8 x 8 dot font registration (PC character set, inside video BIOS ROM)	AH = 11h AL = 02h BL = Character generator bank No.	
Overwriting character map register	AH = 11h AL = 03h BL = Character map register value	
8 x 16 dot font registration (PC character set, inside video BIOS ROM)	AH = 11h AL = 04h BL = Character generator bank No.	
Font registration of user- defined character (Video controller auto set)	AH = 11h AL = 10h BH = Number of vertical bits in character (Horizontal fixed to 8 bits) BL = Character generator bank No. CX = Number of characters to register DX = First character code to register ES:BP = Top address in user-defined table	
8 x 14 dot font registration (PC character set, inside video BIOS ROM) [Video controller auto set]	AH = 11h AL = 11h BL = Character generator bank No.	
8 x 8 dot font registration (PC character set, inside video BIOS ROM) [Video controller auto set]	AH = 11h AL = 12h BL = Character generator bank No.	
8 x 16 dot font registration (PC character set, inside video BIOS ROM) [Video controller auto set]	AH = 11h AL = 14h BL = Character generator bank No.	
Font registration (CGA) in 0:7Ch (INT 1Fh)	AH = 11h AL = 20h ES:BP = Top address in font table	
Font registration (CGA) in 0:10Ch (INT 43h)	AH = 11h AL = 21h BL = 0: (Number of lines per DL register value) 1: 14 lines 2: 25 lines 3: 43 lines CX = Number of vertical bits per character DL = Number of screen lines (When BL = 0) ES:BP = Top address in font table	
8 x 14 dot font registration (PC character set, inside video BIOS ROM) [Graphics]	AH = 11h AL = 22h BL = 0: (Number of lines per DL register value) 1: 14 lines 2: 25 lines 3: 43 lines DL = Number of screen lines (When BL = 00h)	

Operation	Input	Output
Font registration		
8 x 8 dot font registration (PC character set, inside video BIOS ROM) [Graphics]	AH = 11h AL = 23h BL = 0: (Number of lines per DL register value) 1: 14 lines 2: 25 lines 3: 43 lines DL = Number of screen lines (When BL = 00h)	
8 x 16 dot font registration (PC character set, inside video BIOS ROM) [Graphics]	AH = 11h AL = 24h BL = 0: (Number of lines per DL register value) 1: 14 lines 2: 25 lines 3: 43 lines DL = Number of screen lines (When BL = 00h)	
Reading font table data	AH = 11h AL = 30h BL = 0: Return INT 1Fh (CGA font) entry address with ES:BP register. 1: Return INT 43h entry address with ES:BP register. 2: Return 8 x 14 font address with ES:BP register. 3: Return 8 x 8 font address with ES:BP register. 4: Return 8 x 8 font (80h) address with ES:BP register. 5: Reserved	CX = Number of vertical bits per character DL = Number of lines per screen - 1 ES:BP = Address of data specified in BH
Performance selection		
Reading video mode data (Color/B/W mode)	AH = 12h BL = 10h	BH = 0: Color mode 1: B/W mode (MDA mode) BL = Video RAM memory size CH = Reserved CL = DIP switch setting
Selecting video BIOS print-screen	AH = 12h BL = 20h	
Selecting vertical resolution	AH = 12h BL = 30h AL = Selected vertical resolution = 00h: 200 display lines = 01h: 350 display lines = 02h: 400 display lines	AL = 12h Successfully executed
Default pallet load enable/disable	AH = 12h BL = 31h AL = Load selection 0: Default pallet loading enabled 1: Default pallet loading disabled	AL = 12h Successfully executed
Video enable/disable	AH = 12h BL = 32h AL = 0: Video enabled 1: Video disabled	AL = 12h Successfully executed
Gray scale enable/disable	AH = 12h BL = 33h AL = 0: Gray scale enabled 1: Gray scale disabled	AL = 12h Successfully executed

Operation	Input	Output
Performance selection		
Cursor emulator enable/disable	AH = 12h BL = 34h AL = Selection 0: Cursor emulator enabled 1: Cursor emulator disabled	AL = 12h : Successfully executed
Screen ON/OFF	AH = 12h BL = 36h AL = 0: Screen ON 1: Screen OFF	AL = 12h : Successfully executed
Character string output to screen		
Character output without cursor movement	AH = 13h AL = 00h BH = Page No. BL = Attribute CX = Length DH = Starting line position of first character in character string DL = Starting column position of first character in character string ES:BP = Top address in character string	
Character output with cursor movement	AH = 13h AL = 01h BH = Page No. BL = Attribute CX = Number of characters DH = Starting line position of first character in character string DL = Starting column position of first character in character string ES:BP = Top address in character string	
Character output and attribute selection without cursor movement	AH = 13h AL = 02h BH = Page No. CX = Number of characters DH = Starting line position of first character in character string DL = Starting column position of first character in character string ES:BP = Top address in character string	
Character output and attribute selection with cursor movement	AH = 13h AL = 03h BH = Page No. CX = Number of characters DH = Starting line position of first character in character string DL = Starting column position of first character in character string ES:BP = Top address in character string	
Display combination code		
Reading display combination code	AH = 1Ah AL = 00h	AL = 1Ah : Successfully executed BL = Active-display code BH = Nonactive-display code
Writing display combination code	AH = 1Ah AL = 01h BL = Active-display code BH = Nonactive-display code	AL = 1Ah : Successfully executed
Status information	AH = 1Bh BX = Implementation type ES:DI = Return information buffer	AL = 1Bh : Successfully executed

Operation	Input	Output
Video status save & restore		
Reading buffer size	AH = 1Ch AL = 00H CX = Request status Bit 0: Video hardware status Bit 1: Video BIOS data area Bit 2: Expansion pallet register ssave / restore	AL = 1Ch : Successfully executed BX = Buffer size in 64-byte units
Status save	AH = 1Ch AL = 01h CX = Request status Bit 0: Video hardware status Bit 1: Video BIOS data area Bit 2:Expansion pallet register ssave / restore ES:BX = Address of data save area	AL = 1Ch : Successfully executed
Status save as	AH = 1Ch AL = 02h CX = Request status Bit 0: Video hardware status Bit 1: Video BIOS data area ES:BX = Bit 2: Expansion pallet register ssave / restore	

■ INT 11h Reading System Data

Operation	Input	Output
Reading system data		AX = System configuration data AX bit : Number of printer ports : Number of RS-232C Bits 15 & 14 : ports Bits 11, 10 & 9 : Number of internal Bits 7 & 6 : FDDs 0, 0 : 1 0, 1 : 2 Bits 5 & 4 : Screen mode 0, 1 : 40 x 25 line mode 1, 0 : 80 x 25 line mode Bit 1 : 80287 CPU yes/no 0 : No 1 : Yes Bits 13, 12, 8, 3, 2 & 0 : Reserved

■ INT 12h Reading Memory Size

Operation	Input	Output
Reading memory size		AX =Memory size in 1 K units

■ INT 13h Disk BIOS

Operation	Input	Output																																														
Disk reset	AH = 00h DL = Drive No. (FDD:00h-01h;HDD:80h-81h)	CY = 0: Successfully completed = 1: Error AH = Status Floppy disk status table <table border="1"> <thead> <tr> <th>Status</th> <th>Description</th> </tr> </thead> <tbody> <tr> <td>00h:</td> <td>Successfully completed</td> </tr> <tr> <td>01h:</td> <td>Wrong command sent</td> </tr> <tr> <td>02h:</td> <td>Cannot find address mark.</td> </tr> <tr> <td>03h:</td> <td>Attempted writing on protected disk</td> </tr> <tr> <td>04h:</td> <td>Cannot find requested sector.</td> </tr> <tr> <td>06h:</td> <td>Disk was changed.</td> </tr> <tr> <td>08h:</td> <td>DMA overrun</td> </tr> <tr> <td>10h:</td> <td>CRC error during diskette reading</td> </tr> <tr> <td>20h:</td> <td>Crashed FDC</td> </tr> <tr> <td>80h:</td> <td>Crashed during seek operation Timer overflowed</td> </tr> </tbody> </table> Hard disk status table <table border="1"> <thead> <tr> <th>Status</th> <th>Description</th> </tr> </thead> <tbody> <tr> <td>00h:</td> <td>Successfully completed</td> </tr> <tr> <td>01h:</td> <td>Wrong command sent</td> </tr> <tr> <td>02h:</td> <td>Cannot find address mark.</td> </tr> <tr> <td>04h:</td> <td>Cannot find requested sector.</td> </tr> <tr> <td>07h:</td> <td>Drive parameter error</td> </tr> <tr> <td>08h:</td> <td>DMA overrun</td> </tr> <tr> <td>10h:</td> <td>Error during reading</td> </tr> <tr> <td>20h:</td> <td>Crashed HDC</td> </tr> <tr> <td>40h:</td> <td>Crashed during seek operation</td> </tr> <tr> <td>80h:</td> <td>Timer overflowed</td> </tr> <tr> <td>BBh:</td> <td>Undefined error</td> </tr> </tbody> </table>	Status	Description	00h:	Successfully completed	01h:	Wrong command sent	02h:	Cannot find address mark.	03h:	Attempted writing on protected disk	04h:	Cannot find requested sector.	06h:	Disk was changed.	08h:	DMA overrun	10h:	CRC error during diskette reading	20h:	Crashed FDC	80h:	Crashed during seek operation Timer overflowed	Status	Description	00h:	Successfully completed	01h:	Wrong command sent	02h:	Cannot find address mark.	04h:	Cannot find requested sector.	07h:	Drive parameter error	08h:	DMA overrun	10h:	Error during reading	20h:	Crashed HDC	40h:	Crashed during seek operation	80h:	Timer overflowed	BBh:	Undefined error
Status	Description																																															
00h:	Successfully completed																																															
01h:	Wrong command sent																																															
02h:	Cannot find address mark.																																															
03h:	Attempted writing on protected disk																																															
04h:	Cannot find requested sector.																																															
06h:	Disk was changed.																																															
08h:	DMA overrun																																															
10h:	CRC error during diskette reading																																															
20h:	Crashed FDC																																															
80h:	Crashed during seek operation Timer overflowed																																															
Status	Description																																															
00h:	Successfully completed																																															
01h:	Wrong command sent																																															
02h:	Cannot find address mark.																																															
04h:	Cannot find requested sector.																																															
07h:	Drive parameter error																																															
08h:	DMA overrun																																															
10h:	Error during reading																																															
20h:	Crashed HDC																																															
40h:	Crashed during seek operation																																															
80h:	Timer overflowed																																															
BBh:	Undefined error																																															
Reading disk drive data	AH = 01h DL = Drive No. (FDD:00h-01h, HDD:80h-81h)	AH = Disk drive status																																														
Reading sector	AH = 02h AL = Number of sectors CH = Track No. CL = Sector No. CH = Cylinder No. CL = Insignificant 8 bits Sector No. (Bits 0 - 6) = Cylinder No. Significant 2 bits (Bits 7 - 8) DH = Head No. DL = Drive No. (FDD: 00h - 01h, HDD: 80h - 81h) ES:BX = Buffer address	CY = 0: Successfully completed = 1: Error AH = Status																																														

Operation	Input	Output
Writing sector	AH = 03h AL = Number of sectors CH = Track No. CL = Sector No. CH = Cylinder No. Insignificant 8 bits CL = Sector No. (Bits 0 - 6) = Cylinder No. Significant 2 bits (Bits 7-8) DH = Head No. DL = Drive No. (FDD: 00h - 01h, HDD: 80h - 81h) ES:BX = Buffer address	CY = 0: Successfully completed = 1: Error AH = Status
Sector content check	AH = 04h AL = Number of sectors CH = Track No. CL = Sector No. CH = Cylinder No. Insignificant 8 bits CL = Sector No. (Bits 0 - 6) = Cylinder No. Significant 2 bits (Bits 7- 8) DH = Head No. DL = Drive No. (FDD: 00h - 01h, HDD: 80h - 81h)	CY = 0: Successfully completed = 1: Error AH = Status
Track/Cylinder format	AH = 05h AL = Track/Cylinder No. Insignificant 8 bits CL = Track/Cylinder No. Significant 2 bits (Bits 7 - 8) DH = Head No. DL = Drive No. ES:BX = Top address in format data table	CY = 0: Successfully completed = 1: Error AH = Status
Reading drive parameters	AH = 08h DL = Drive No. (FDD: 00h - 01h, HDD: 80h - 81h)	CY = 0: Successfully completed = 1: Error AH = Status When FDD drive No. specified in DL ES:DI = Drive parameter starting address CH = Insignificant 8 bits in 10 bit value for max. number of tracks CL = Bits 7 & 6: Insignificant 2 bits in 10 bit value for max. number of tracks Bits 5 - 0: Max. number of sectors per track DH = Max. number of heads DL = Number of built-in floppy disk drives BL = Bits 3 - 0: CMOS valid drive type value Bits 7 - 4: Fixed to 0 When HDD drive No. specified in DL CH = Max. number of cylinders CL = Max. number of usable sectors and Significant bit in max. number of cylinders DH = Max. number of usable heads DL = Number of built-in hard disk drives

Operation	Input	Output
Hard disk drive parameter initialization	AH = 09h DL = Drive No.	CY = 0: Successfully completed = 1: Error AH = Status
Hard disk seek	AH = 0Ch CH = Insignificant 8 bits in cylinder No. CL = Significant 2 bits in cylinder No. DL = Drive No. DH = Head No.	CY = 0: Successfully completed = 1: Error AH = Status
Hard disk drive reset	AH = 0Dh DL = Drive No.	CY = 0: Successfully completed = 1: Error AH = Status
Hard disk drive ready check	AH = 10h DL = Drive No.	CY = 0: Successfully completed = 1: Error AH = Status
Hard disk drive recalibration	AH = 11h DL = Drive No.	CY = 0: Successfully completed = 1: Error AH = Status
Disk type check	AH = 15h DL = Drive No.	CY = 0: Successfully completed = 1: Error CX:DX = Total number of sectors (HDD only) AH = 00h: No disk = 01h: Floppy disk unchanged = 02h: Disk was changed = 03h: Hard disk
Media change check	AH = 16h DL = Drive No.	AH = 00h: Disk unchanged = 01h: Inconsistent parameter = 06h: Disk was changed (Carry bit ON) = 80h: Drive not ready
Setting drive type for formatting	AH = 17h DL = Drive No. AL = 0: No disk 1: Use 2-sided disk on 2-sided drive. 2: Use 2-sided disk on high-density drive. 3: Use 2HD disk on high-density drive. 4: Use 720K disk on 720K-byte drive.	CY = 0: Successfully completed = 1: Error AH = Status
Setting media type for formatting	AH = 18h CH = Insignificant 8 bits in 10 bit value for max. number of tracks CL = Bits 7 & 6: 10 bit value for max. number of tracks Bits 5 - 0: Max. number of sectors per track DL = Drive No.	ES:DI = Address of drive parameter table for floppy disk type AH = 00h and CY =0: Supports tracks and number of tracks per sector. AH = 01h and CY =1: Cannot use function. AH = 00h and CY =1: Does not support tracks and number of tracks per sector.

■ INT 14h RS-232C

Operation	Input	Output
Setting RS-232C line mode	AH = 00h AL = Line mode/Parameter Bits 7, 6, 5: Baud rate 0, 0, 0: 110 Bauds 0, 0, 1: 150 Bauds 0, 1, 0: 300 Bauds 0, 1, 1: 600 Bauds 1, 0, 0: 1200 Bauds 1, 0, 1: 2400 Bauds 1, 1, 0: 4800 Bauds 1, 1, 1: 9600 Bauds Bits 4&3: Parity X, 0: No parity 0, 1: Odd parity 1, 2: Even parity Bit 2: Stop bits 0: 1 bit length 1: 2 bit length Bits 1&0: Word length 1, 0: 7 bits 1, 1: 8 bits DX = Port No.	
Sending 1-byte data	AH = 01h AL = Data to send DX = Port No.	AH = Line control status Bit 7: Time over error Bit 6: Transmission shift register empty Bit 5: Transmission hold register empty Bit 4: Break detected Bit 3: Framing error Bit 2: Parity error Bit 1: Overrun Bit 0: Data ready
Receiving 1-byte data	AH = 02h DX = Port No.	AL = Received data AH = Line control status
Reading communication port status	AH = 03h DX = Port No.	AL = Line control status AL = Modem status Bit 7: Carry detected Bit 6: Call signal received Bit 5: Data-set ready Bit 4: Transmission enabled (CTS) Bit 3 - 0: Not in use

■ INT 15h Other System Services

Operation	Input	Output
Wait time check	AH = 83h AL = 00h: Interval timer start 01h: Interval timer stop ES:BX = End flag address CX:DX = Wait time in 1 µsec units	CY = 0: Successfully completed = 1: Error

Operation	Input	Output								
Joystick										
Reading button status	AH = 84h DX = 00h	AL = Button status 00h: Pressed 01h: Not pressed Bit 7: 2nd button status on 2nd joystick Bit 6: 1st button status on 2nd joystick Bit 5: 2nd button status on 1st joystick Bit 4: 1st button status on 1st joystick								
Reading resistance value	AH = 84h DX = 01h	AX = Resistance value of horizontal coordinate of 1st joystick BX = Resistance value of vertical coordinate of 1st joystick CX = Resistance value of horizontal coordinate of 2nd joystick DX = Resistance value of vertical coordinate of 2nd joystick								
Wait timer overwait	AH = 86h CX:DX = Wait time in μ sec units	CY = 0: Successfully completed = 1: Already triggered or not supported								
Transmitting memory block in protect mode	AH = 87h ES:SI = Top address in descriptor ES:SI = <table border="1" style="margin-left: 20px;"><tr><td>Dummy (00h)</td></tr><tr><td>GDT (00h)</td></tr><tr><td>Source segment descriptor</td></tr><tr><td>Destination segment descriptor</td></tr><tr><td>BIOS CS (00h)</td></tr><tr><td>SS (00h)</td></tr></table> CX = Number of words to transfer	Dummy (00h)	GDT (00h)	Source segment descriptor	Destination segment descriptor	BIOS CS (00h)	SS (00h)	ZF = 1: Successfully completed CY = 1: Error AH = 00h: Successfully completed = 01h: RAM parity error = 02h: Not in protect mode		
Dummy (00h)										
GDT (00h)										
Source segment descriptor										
Destination segment descriptor										
BIOS CS (00h)										
SS (00h)										
Engaging the protect mode	AH = 89h BH = Offset of insignificant (mask) interrupt vector address BL = Offset of significant (slave) interrupt vector address ES:SI = Top address in below table <table border="1" style="margin-left: 20px;"><tr><td>CS dummy (00h)</td></tr><tr><td>GDT</td></tr><tr><td>IDT</td></tr><tr><td>DS</td></tr><tr><td>ES</td></tr><tr><td>SS</td></tr><tr><td>CS</td></tr><tr><td>TEMP BIOS CS(00h)</td></tr></table>	CS dummy (00h)	GDT	IDT	DS	ES	SS	CS	TEMP BIOS CS(00h)	CY = 0: Successfully completed AH = 00h CS = CS value specified in ES:SI table DS = DS value specified in ES:SI table ES = ES value specified in ES:SI table SS = DS value specified in ES:SI table CY = 1: Error AH = FFh
CS dummy (00h)										
GDT										
IDT										
DS										
ES										
SS										
CS										
TEMP BIOS CS(00h)										

■ INT 16h Keyboard BIOS

Operation	Input	Output
Reading data by key input	AH = 00h	AH = Secondary code AL = Primary code (Character code)
Data check by key input	AH = 01h	ZF = 0: Input data exists. = 1: Input data does not exist. AH = Secondary code AL = Primary code (Character code)
Reading shift status	AH = 02h	AL = Shift status
Setting repeat delay and repeat rate	AH = 03h AL = 05h BH = Delay time (Bits 0 &1) BL = Primary code (Bits 0 - 4)	
Writing key data	AH = 05h CH = Secondary code CL = Primary code	AL = 00h: Successfully completed = 01h: No available space in buffer (CY =1)
Wiring data by key input (101/AXkeyboard compatible)	AH = 10h	AH = Secondary code AL = Primary code (Character code)
Data check by key input (101/AXkeyboard compatible)	AH = 11h	ZF = 0: Input data exists. = 1: Input data does not exist. AH = Secondary code AL = Primary code (Character code)
Reading shift status (101/AX keyboard compatible)	AH = 12h	AL = Shift status 1 AH = Shift status 2

■ INT 17h Printer BIOS

Operation	Input	Output
1-character output	AH = 00h AL = Character code of character to DX = output Device No.	AH = Printer status
Printer initialization	AH = 01h DX = Device No.	AH = Printer status
Status check	AH = 02h DX = Device No.	AH = Printer status

■ INT 1Ah Setting/Reading Time and Date

Operation	Input	Output
Reading clock	AH = 00h	CX = Significant 16 bits of current clock data DX = Insignificant 16 bits of current clock data AL = Overflow flag on 24-hour system
Setting clock	AH = 01h CX = Significant 16 bits of clock data DX = Insignificant 16 bits of clock data	
Reading time	AH = 02h	CH = Hours (BCD) CL = Minutes (BCD) DH = Seconds (BCD) DL = Summertime option (0 or 1) CY = End status 0: Successfully completed 1: Error
Setting time	AH = 03h CH = Hours (BCD) CL = Minutes (BCD) DH = Seconds (BCD) DL = Summertime option (0 or 1)	
Reading date	AH = 04h	CH = Western calendar (Year given as 2-digit BCD, significant 2 bits: 19 or 20) CL = Year (BCD) DH = Month (BCD) DL = Day (BCD) CY = End status 0: Successfully completed 1: Error
Setting date	AH = 05h CH = Western calendar (Year given as 2-digit BCD, significant 2 bits: 19 or 20) CL = Year (BCD) DH = Month (BCD) DL = Day (BCD)	
Setting alarm	AH = 06h CH = Hours (BCD) CL = Minutes (BCD) DH = Seconds (BCD)	CY = End status 0: Successfully completed 1: Error
Clearing alarm	AH = 07h	

INDEX

Symbols

100V	4- 7
12.1" LCD	pref- xi
170 - 265V	1- 1
50/60 Hz	7- 3
85 - 132V	1- 1

A

AC power terminals	4- 8
Accessories	1- 2
aerospace equipment	pref- iii
Afterimage	pref- v
ambient humidity	7- 3
ambient temperature	4- 4
Analog Resistance Film Touch Panel	1- 1
Analog RGB Connector	2- 6
Analog-Resistance-Film	pref- xi
Angle Plate	pref- xii
arc-generating devices	4- 4
arrow keys	5- 1
Attachment Brackets	4- 4
attachment screws	3- 4, 3- 9
automatic detection	5- 13
Available Options and Expansion Boards	3- 10

B

backlight	7- 3
Backlight Lamp (CFL type)	1- 1
BIOS FEATURES SETUP	5- 1, 5- 4
blank panel	3- 10
Boot Sequence	5- 4
brightness	
conditions	pref- iv
variations	pref- iv
Bundled Software	6- 1

C

Cautions When Connecting I/O Signal Lines	4- 9
CD-ROM drive	3- 12
CHIPSET FEATURES SETUP	5- 6
Class 3 Ground	4- 9
Cleaning the Display	7- 1
Com 3 & Com 4 Mode	5- 12
Com 3 Port Resource	5- 12
Com 4 Port Resource	5- 12
COM Ports Activity	5- 8
Commercially Available Products	3- 2
condensation	pref- iv
conduits	4- 9
Connecting the Power Cord	4- 6
connecting the power cord	4- 6
connection cable	7- 3
Constant voltage transformer	4- 8

corrosive gas	7- 3
corrosive gases	4- 4
CPU Internal Cache	5- 4
crime prevention devices	pref- iii
crimp terminals	4- 7
crosstalk	pref- v

D

damage the screen	pref- iv
DC -5V/ -12V	1- 1
DC Input	3- 12
DC OUT connector	3- 12
DC power cable	3- 12
deadman (two-handed) start switch	pref- iii
Dedicated ground	4- 9
Digital Electrical Corporation Optional Products	3- 1
DIM modules	3- 2
Dimensions	pref- vii
DIMM module sockets	3- 4
DIMM Socket	3- 4
DIMM socket	3- 5
DIMM sockets	1- 1
direct sunlight	pref- iv
Display Area	2- 6
Display check	7- 3
Display Functions	pref- vii
Display Unit (COLOR STN, TFT)	1- 1
Displayed color	pref- v
Doze Speed	5- 7
Driver & Utility Disk	pref- x

E

electric hazards	3- 3, 4- 6
electric shocks	4- 6
electrical shock	pref- iii
Electrical Specifications	pref- vii
Environment Specifications	pref- vii
equipment damage	4- 6
Essential Safety Precautions	pref- vii
excessive vibration	4- 2
Expansion Board	3- 10
expansion boards	pref- xi
Expansion Options	1- 2
Expansion Slots	pref- vii, 2- 3, 2- 6
External Cache	5- 4

F

factory automation	pref- i
failsafe system design	pref- iii
FDD connection cable	3- 6
FDD connector	3- 6
Features	pref- vii, pref- xi
ferrite core	4- 8
FG terminal	4- 9

- fire 4- 6
- flammable gases pref- iii
- Floppy Disk Insertion Slot 2- 6
- front and side connectors 2- 4
- Front Keyboard Connector 1- 1
- Front Maintenance Cover 2- 6
- Front Mount FD Unit 1- 1
- Front Panel Installation pref- xi
- full-sized boards 2- 3
- full-sized expansion board 3- 10
- ## G
- General Safety Precautions pref- v, pref- vii
- General Specifications pref- vii
- Graphic Panel
- Caution pref- xii
- grid-points pref- iv
- Grounding Cautions 4- 9
- grounding point 4- 9
- grounding resistance 4- 9
- ## H
- hardware setup pref- x
- hazardous situation pref- ii
- HDD Cover 2- 6
- HDD LOW LEVEL FORMAT 5- 14
- HDD Off After 5- 8
- high temperatures pref- iv
- high voltages pref- iii
- High-Performance Architecture pref- xi
- humidity pref- iv
- ## I
- I/O device 4- 8
- I/O power source 4- 8
- I/O signal lines 4- 8
- icons pref- ii
- IDE Burst Mode 5- 11
- IDE Date Port Post Write 5- 11
- IDE HDD AUTO DETECTION 5- 13
- incompatible boards 3- 2
- Information Symbols pref- vii
- Install the OS pref- x
- Installation and Wiring pref- iii
- Installation Brackets pref- xii
- Installation Procedures 4- 3
- Installing Optional Units and Expansion Boards 3- 1
- Installing Options and Expansion Boards 3- 3
- Installing the DIM Module 3- 4
- Installing the FDD Unit 3- 6
- Installing the HDD Unit 3- 7
- Installing the IDE Slave Adaptor 3- 11
- Installing the PL 4- 3
- insulating transformer 4- 8
- INTEGRATED PERIPHERALS SETUP 5- 11
- interface connector pref- iii
- Interface Specifications pref- vii, 2- 4
- internal data flow 1- 1
- Internal PCI/IDE 5- 11
- Introduction pref- i
- Inverter Unit 1- 1
- IrDA 2- 6
- IrDA I/F Unit 1- 1
- ISA Slots 1- 1
- ISA(AT)-bus compatible boards 3- 2
- ISA-bus expansion slots pref- xi
- ## K
- Keyboard Connector 2- 7
- KEYBOARD ACTION KEYS 5- 1
- Keyboard Connector 2- 6
- ## L
- LCD surface pref- iv
- lightning 4- 8
- lightning surge absorber 4- 8
- low-noise power supply 4- 8
- ## M
- machine breakdown 4- 2
- magnetic switches 4- 4
- Main Board's HDD connector 3- 11
- main board's HDD connector 3- 12
- main circuit 4- 8
- Main Circuit Board 1- 1
- Main Memory 3- 2
- Main power source 4- 8
- maintainability 4- 3
- Maintenance and Inspection 7- 1
- Maintenance Cover 2- 6, 2- 7
- maintenance cover 3- 10
- Maintenance Options 1- 2
- medical devices pref- iii
- metal particles pref- iii
- minor injury pref- ii
- Model number 1- 3
- module's clips 3- 5
- moisture resistance 4- 3, 4- 5
- moisture resistant packing 7- 3
- moisture resistant seal 4- 3
- mounting hole 4- 3
- Mounting panel 4- 5
- Mouse 1- 1
- Mouse Connector 2- 7
- mouse emulation utility pref- xi
- ## N
- neutral detergent 7- 1
- noise immunity 4- 8
- non-fuse breakers 4- 4

Index

Notes on Handling the LCD pref- iv
nuclear power control devices pref- iii

O

Onboard FDC Controller 5- 12
Onboard Parallel Port 5- 12
Onboard Serial Port1 5- 12
Onboard Serial Port2 5- 12
operator 4- 4
Options 1- 2
organic solvents 7- 1
OS (operating system) 6- 1
overheating pref- iv
overseas products pref- i
Overview pref- vii

P

panel 2- 11, 4- 3
panel's viewing angle 4- 1, 4- 4
PC/AT compatible multi-scan monitor 2- 6
PCI slots pref- xi
Performance Specifications pref- vii
Periodic Check 7- 3
peripheralconnection 1- 1
pinch collar 3- 6
PL power source 4- 8
PL Series Panel Types pref- vii
PL Software 6- 1
PL-6700 Floppy Disk File List 6- 1
PL-6700 Unit pref- xii
PL-HD100 3- 7
PL-IR100 2- 6
PL-SA100 3- 11
Plastic Cover 4- 6
PL's backlight 7- 3
PL's frame 4- 6
pointed object pref- iv
possible explosion pref- iii
Power Cord pref- xii
power cord 2- 7, 4- 6
Power Input Terminal Strip 2- 7
Power Input Terminals 4- 6
Power Management 5- 7
POWER MANAGEMENT SETUP 5- 7
Power Supply Cautions 4- 8
power supply devices 4- 8
Power Supply Unit 1- 1
power supply voltage 4- 6
Power Switch 2- 7
pre-set 5- 1
Primary Master 5- 2
Primary Slave 5- 2
Printer Connector (LPT1) 2- 6
Printer Interface pref- vii, 2- 4
Prior To Using the PL pref- xi
Protection sheet 7- 1

PS-2 type keyboard 2- 4
PS/2 type keyboard pref- x

R

Rear Maintenance Cover 2- 7
rear maintenance cover 3- 4, 3- 9
Reset Configuration Data 5- 9
Reset Switch 1- 1
Resources Controlled By 5- 9
RS-232C Connector (COM1) 2- 6
RS-232C Connector (COM2) 2- 6
RS-232C Connector (COM3) 2- 6

S

Safe Product Usage pref- vii
Safety Icons pref- ii
Screen display pref- v
screen protection sheet 7- 1
screw size 4- 6
separate control system pref- iii
Shared ground 4- 9
socket's contacts 3- 5
Software Options 1- 2
specified view angle pref- v
specified voltage 4- 8
STANDARD CMOS SETUP 5- 2
Stdby Speed 5- 7
strong acids 7- 1
strong irritant pref- iv
support leg 3- 3
System Configuration pref- vii
System Parameters 5- 1
SYSTEM SETTING SELECTION AREA 5- 1

T

Table of Contents pref- vii
Temperature Related Cautions 4- 1
terminal strip 4- 7
TFT Color LCD 1- 3
thinner or organic solvents pref- iv
Touch Panel 2- 6
touch panel switches pref- iii
transparent plastic cover 4- 6
transportation vehicles pref- iii
Twisted-pair cable 4- 8

U

Unpacking the PL pref- vii
User supplied item 1- 1
utility software pref- x

V

ventilation 4- 3
Vibration Related Cautions 4- 2
Video BIOS Shadow 5- 5

Video Off method 5- 7
Video Off Option 5- 7
Virus Warning 5- 4

W

weight 2-1
warranty 3- 2
water resistance 2- 11
Windows NT 6- 1
Windows NT driver 1- 2
Wiring the PL 4- 6