

# PL-CF200

## Installation Guide

This CF Card unit (PL-CF200) is made by Pro-face for use with PL Series Panel computers, hereafter referred to as the "PL".

Corresponding PL units: PL-5900/PL-5910/ PL-X900/ PL-X920/ PL-X930 Series units  
(All product names that appear in this guide are the trademarks of their respective companies)

Pro-face: Digital Electronics Corporation (in Japan and other countries)

MS-DOS, Windows: Microsoft Corporation (USA)



## WARNINGS

- **Be sure to check that the PL's power is disconnected before installing the unit, in order to prevent an electrical shock.**
- **Do not attempt to modify or open the PL-CF200, due to the dangers of shock and fire.**
- **When installing the PL-CF200, be sure to read the following "3. Installation" section's information completely to insure that the unit is correctly installed.**

### To Prevent Accidents

- Since the PL-CF200 is a precision instrument, be sure it is neither hit by nor pressed strongly against another object.
- The PL-CF200 is designed to use only CF Cards whose rated voltage is DC 5V. Be sure not to use any other type of CF Card.
- Be sure water, liquids or metal particles are not allowed to enter the unit. Any of these may cause either a breakdown or an electrical shock.
- Do not place or store this unit in a location where there is direct sunlight, excessive heat, dust or vibration.
- Do not store or operate this unit near chemicals, or where there are chemical fumes.
- Do not allow anyone other than service staff trained by Pro-face to perform maintenance or make adjustments to this unit.
- Do not use the PL-CF200 in locations where corrosive gasses are present.
- To prevent damage to file data, be sure to shut down the PL unit's OS before turning OFF the main power.

### Unit Disposal

- When the product is disposed of, it should be done so according to your country's regulations for similar types of industrial waste.

# Package Contents

Please check that the following items are included in your package.

■ **PL-CF200 (1)**

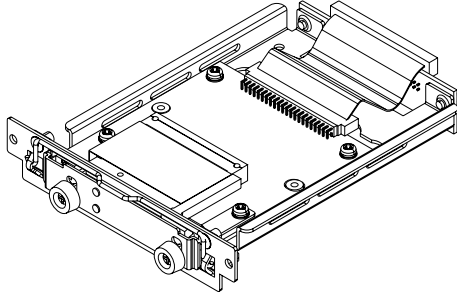

■ **Installation Guide  
(PL-CF200)**

**Installation  
Guide**

Digital has taken the utmost care to insure the quality of this product when it was shipped, however, should, for any reason, problems or damage have occurred during shipping, please contact your Pro-face representative immediately for service.

## 1 Hardware Specifications

### ■ Features

Rated Voltage	5V (supplied from the PL)
Compatible CF Cards	Cards based on CFA standard (Only 5V cards supported)
CF Card Interface	True-IDE mode

### ■ Environment

Surrounding Air Temperature	0°C to 50°C
Storage Temperature	-10°C to +60°C
Ambient Humidity	30%RH to 85%RH (no condensation)
Dust	0.1mg/m <sup>3</sup> or less (Non-conductive particles)
Atmosphere	Free of corrosive gases
Vibration Resistance	19.6m/s <sup>2</sup> (10Hz to 25Hz) X,Y,Z directions for 30 minutes



The environment specifications given here are for a unit installed in a PL, that is built into a solid panel.

## ■ External

Cooling Method	Natural air Circulation
Weight	Approx. 200g (without CF Card)

## 2 CF Card Unit Settings

The PL-CF200 is factory set for use as the PL's Slave drive, however, if the user desires, this setting can be changed so that the PL-CF200 can be used as the PL's Master drive. Refer to the following diagram when changing the Master/Slave Setting Switch.



- Be sure to check that the PL's power is disconnected before changing the Master/Slave Setting Switch.
- Be sure to use the PL-CF200 as Master setting for PL-X930 Series units.
- When using both Pro-face's CD-ROM drive unit "PSS-CD01" and this unit (PL-CF200) built in PL-X930 Series unit's Expansion Slot 1, be sure to set PL-CF200's drive as Master, since it can cause a malfunction.

### PL-CF200 <Front Face View>

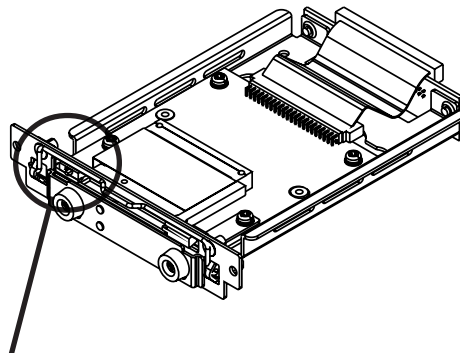

Master/Slave Setting Switch	
Master Setting	Slave Setting
 M    S	 M    S (Factory Setting)

### 3 Installation

Use the following steps to install the PL-CF200 in the PL. Even though the unit shown below is a PL-X920 Series unit, the other corresponding PL units' installation procedures are the same for all compatible PL Series units.

## WARNING

- **Shock Danger!** Be sure to unplug the PL unit from its power supply prior to installing the PL-CF200.
- Even when the PL-X930 Series unit's screen display disappears, the power might be distributed inside (such as the "Soft OFF" status\*1 etc). Be sure to confirm that the power supply switch on the rear side of the PL unit is OFF.



Since the PL-CF200 is a precision instrument, be sure it is neither hit by nor pressed strongly against another object.

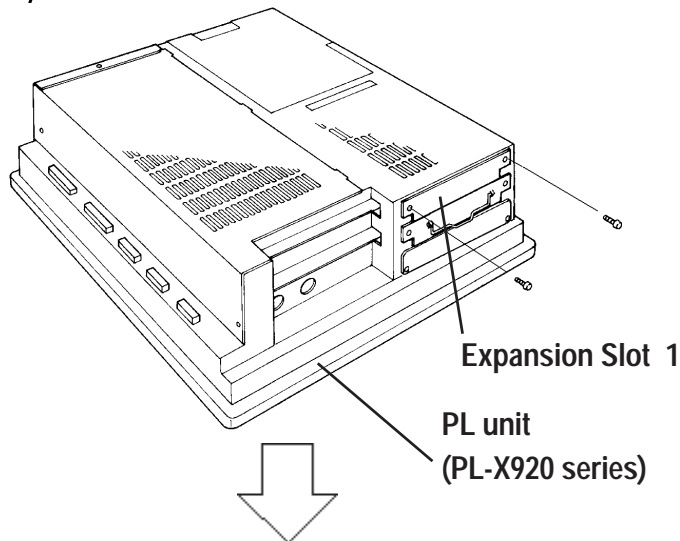

- 1) Remove the uppermost (Expansion Slot 1) expansion slot cover's two (2) attachment screws.

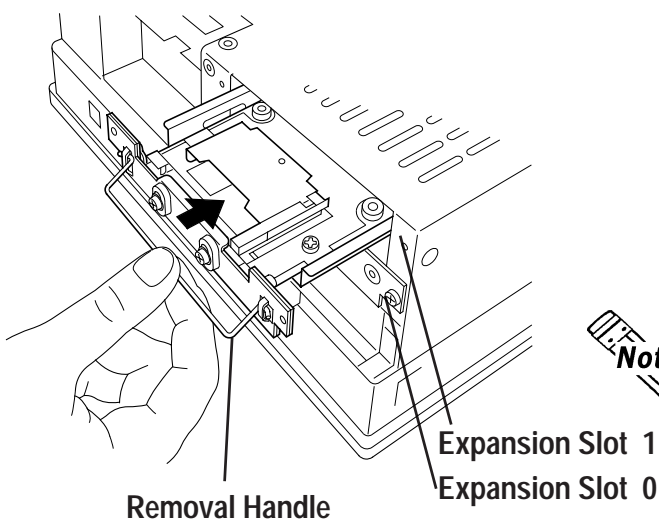

- 2) Hold the PL-CF200's removal handle and push the unit slowly into the expansion slot, so that the rear face connector is completely inserted into the slot's connector pins.
- 3) Reattach the two (2) expansion slot cover attachment screws.



**Note:** The installation procedures are the same When installing an CF Card unit in Expansion Slot 0.

\*1 The Soft OFF refers to the state that Windows(R) has been shut down and the power is provided only for the electric circuit to boot system. This Soft OFF State is different from what is System Standby set by Windows(R).



## CAUTIONS

### CF Card Handling

- The CF Cards manufactured by the Digital Electronics Corporation are recommended for use with this unit. The performance of this CF Card Unit cannot be guaranteed when using another manufacturer's CF Card.
- Be sure to use a CF Card with a rated voltage of DC 5V.
- Be sure to follow the instructions given below to prevent the CF Card's internal data from being destroyed or a CF Card malfunction from occurring:
  - DO NOT bend the CF Card.
  - DO NOT drop or strike the CF Card against another object.
  - Keep the CF Card dry.
  - DO NOT touch the CF Card's connector holes or the CF card unit's connector pins.
  - DO NOT disassemble or modify the CF Card.

### When using the CF Card Unit and the CF Card

- Prior to inserting the CF Card, be sure to confirm that the rear and the front of the CF Card are correctly oriented, and that the CF Card connector position is correct. If the CF Card is inserted incorrectly, the CF Card, its internal data, and the CF card unit may be damaged.
- Prior to inserting or removing the CF Card, be sure to turn OFF the PL to prevent damaging file data and stopping OS. When operating, PL-CF200 regards the CF Card as the hard disk.
- Never turn OFF or reset the PL while accessing the CF Card to prevent damaging file data. Also, be sure to shut down the PL unit's OS before turning OFF the main power.

#### ■ Data Overwrite Limit

The CF Card has a data overwrite limit of approximately 300,000 times. Therefore, be sure to back up all CF Card data regularly to another storage media. (300,000 times assumes the overwriting of 500KB of data in DOS format)

#### ■ CF Card Insertion and Removal

Familiarize yourself with the differences between the top and bottom surfaces of the CF Card. Also, be sure to read the CF Card's operation manual to ensure that the CF Card is properly oriented when it is inserted (i.e. whether the top of the card is up or down etc.)

#### ■ Inserting the CF Card

- 1) Turn OFF the PL unit's main power.

- 2) Hold the CF Card by the end opposite the connector and insert it into the CF Card slot until the eject button is pushed forward. If the card seems to jam or does not move smoothly, remove the CF Card. Confirm that the card is properly oriented and that there are no obstructions in the sides of the CF card unit's insertion slots.
- 3) Pivot (Push) the eject button 90° to the right, until it is clear of the front cover.
- 4) Close the front cover and tighten the two (2) attachment screws.

### ■ Removing the CF Card

- 1) Turn OFF the PL unit's main power.
- 2) Unscrew the two (2) attachment screws and open the front cover.
- 3) Pivot the eject button outwards and push it in. Grasp the edges of the CF Card with your fingers, and slowly pull it out.

## 5 Hardware Setup



**Normally, the factory default settings should be used.**



- All the following explanation screens use the PL's factory settings (default settings).
- Certain BIOS screen items may differ from those shown here due to new versions.

### When using a PL-X900 series unit:

- 1) Connect a keyboard to the PL.
- 2) Turn the PL unit's power ON.
- 3) When the "Press <DEL> to enter SETUP" message appears, press your PC's [DEL] key. The Setup utility will start. Select the [STANDARD CMOS SETUP] and the following screen will appear.

ROM PCI/ISA BIOS(2A5LEU1C)						
STANDARD CMOS SETUP						
AWARD SOFTWARE, INC.						
Date (mm:dd:yy): Thu, Apr 26 2001						
Time (hh:mm:ss): 14 : 50 : 3						
	CYLS.	HEADS	PRECOMP	LANDZONE	SECTORS	MODE
<b>Drive C :Auto( 0b)</b>	0	0	0	0	0	AUTO
<b>Drive D :Auto( 0b)</b>	0	0	0	0	0	AUTO
Drive A :1.44M,3.5 in.				Base Memory : 640K Extended Memory: 31744K Other Memory: 384K		
Video :	EGA/VGA					
VGA_Text Mode:	Normal					
Halt On:	All, But Keyboard					
Total Memory: 32768K						
ESC:Quit		↑↓→←: Select Item		PU/PD/+/-: Modify		
F1:Help		(Shift)F2: Change Color				

- 4) Confirm that the C and D drives are both set to [Auto]. This designates that when the PL is started up, the hard disk's parameters are automatically read out and used. If [Auto] is not selected, be sure to select it. The [Auto] setting is factory set and recommended for most users.
- 5) Press the [ESC] key, select [SAVE & EXIT SETUP] and save all setting data.

**When using a PL-5900/PL-5910/PL-X920 series unit:**

Even though the BIOS screen shown below is for PL-5900 Series unit, the PL-5910/PL-X920 Series setup procedures is the same.

- 1) Connect a keyboard to the PL.
- 2) Turn the PL unit's power ON.
- 3) When the [Press <DEL> to enter SETUP] message appears, press your PC's DEL key. The Setup utility will start.

Select the [STANDARD CMOS SETUP] screen, and from there, select either the IDE Primary Master or IDE Primary Slave menus. Next, the following screen will appear.

CMOS Setup Utility - Copyright (C) 1984-2000 Award Software		Item Help
IDE Primary Master		
IDE HDD Auto-Detection	Press Enter	
<b>IDE Primary Master</b>	<b>Auto</b>	Menu Level ▶▶
Access Mode	Auto	To auto-detect the HDD's size, head...on this channel
Capacity	0 MB	
Cylinder	0	
Head	0	
Precomp	0	
Landing Zone	0	
Sector	0	
↑↓→←: Move    Enter: Select    +/-/PU/PD: Value    F10: Save    ESC: Exit    F1: General Help F5: Previous Values    F6: Fail-Safe Defaults    F7: Optimized Defaults		

- 4) Confirm whether [AUTO] is selected in the Master and Slave screens. If [AUTO] is selected in both, disk parameters will be automatically read when the PL is turned ON. If [AUTO] is not selected, be sure to select it. The factory setting is [AUTO] and recommended for most users. (When using together with HDD unit.)
- 5) After changing all settings, press the [ESC] key and select [Save & EXIT Setup] and save all setting data.

## When using a PL-X930 series unit:

- 1) Connect a keyboard to the PL.
- 2) Right after turn the PL unit's power ON, keep on pressing [F2] key.  
The Setup utility will start.
- 3) Depending on the PL-CF200's installation point (Expansion Slot 0 or 1), the following menu will be displayed.
  - When installing to the Expansion Slot 0: [Primary Master]
  - When installing to the Expansion Slot 1: [Secondary Master]Point the cursor to either [Primary Master] or [Secondary Master] on [Main] menu and press the [Enter] key and the following screen appears.



- **Be sure to use the PL-CF200 as Master setting for PL-X930 Series units. For the details, see [2. CF Card Unit Settings].**

PhoenixBIOS Setup - Copyright 1985-2001 Phoenix Technologies Ltd.		
Main		
Type:	[Auto]	Item Specific Help
Total Sectors:		User = you enter
Maximum Capacity:		Parameters of hard-disk drive installed at this connection.
Multi-Sector Transfer:	[16 Sectors]	Auto = autotypes hard-disk drive installed here.
LBA Mode Control:	[Enabled]	1-39 = you select pre-determined type of hard-disk drive installed here.
32 Bit I/O:	[Disabled]	CD-ROM = a CD-ROM drive is installed here.
Transfer Mode:	[FPIO 4 / DMA 2]	ATAPI Removable = removable disk drive is installed here.
Ultra DMA Mode:	[Mode 5]	
F1 Help   ↓ ↑ Select Item   -/+ Change Values   F9 Setup Defaults		
Esc Exit   ← → Select Menu   Enter Select   ► Sub-Menu   F10 Previous Values		

- 4) Confirm whether "AUTO" is selected for [Type]. (The factory setting is "AUTO" and recommended for most users.)
- 5) Press the [ESC] key and the screen returns to the previous one. Select [Exit] menu and point the cursor to [Exit Saving Changes] and press the [Enter] key. The system settings will be saved and this process will exit and the OS will then start.

### Note

Please be aware that Digital Electronics Corporation shall not be held liable by the user for any damages, losses, or third party claims arising from the uses of this product.

Digital Electronics Corporation

8-2-52 Nanko Higashi, Suminoe-ku, Osaka 559-0031, Japan

URL: <http://www.pro-face.com/>