

# **PL-6920/PL-7920 Series Windows® 2000 Multi Language Preinstalled Hard Disk Package Installation Guide**

The PL-6920/PL-7920 Series Windows® 2000 Multi Language Preinstalled Hard Disk package is a set that includes not only the HDD drive with Microsoft corporation's preinstalled Windows® 2000 operating system, but also the DMC corporation's Mouse Emulation software (TSC-1310D/DD), as well as other driver and utility software, and a recovery media CD-ROM used when operating Pro-face's PL-X920 Series computers, hereafter referred to collectively as the "PL".

Corresponding models: PL-6920/PL-7920 Series units

The following trade names are registered trademarks of the following companies.

Pro-face® : Digital Electronics Corporation (in Japan and other countries)

Windows® 2000: Microsoft Corporation

EasyRestore™: PowerQuest® Corporation

## **IMPORTANT - Read Prior to Opening and Operating**

This HDD unit contains a preinstalled version of Windows® 2000 Professional. Be sure to read and agree with all conditions stated herein prior to using this product. If you do not agree to all the conditions stated in this agreement, please return the entire product.

# COA Data

*\* This Installation Guide is an important part of this product. Be sure to keep it in an easy to find location.*

# Microsoft Corporation Windows<sup>®</sup> 2000

## User Licence Agreement

- You have acquired a device ("DEVICE") that includes software licensed by Digital Electronics Corporation from Microsoft Licensing Inc. or its affiliates ("MS"). Those installed software products of MS origin, as well as associated media, printed materials, and "online" or electronic documentation ("SOFTWARE") are protected by international intellectual property laws and treaties. The SOFTWARE is licensed, not sold. All rights reserved.
- IF YOU DO NOT AGREE TO THIS END USER LICENSE AGREEMENT ("EULA"), DO NOT USE THE DEVICE OR COPY THE SOFTWARE. INSTEAD, PROMPTLY CONTACT Digital Electronics Corporation FOR INSTRUCTIONS ON RETURN OF THE UNUSED DEVICE(S) FOR A REFUND. **ANY USE OF THE SOFTWARE, INCLUDING BUT NOT LIMITED TO USE ON THE DEVICE, WILL CONSTITUTE YOUR AGREEMENT TO THIS EULA (OR RATIFICATION OF ANY PREVIOUS CONSENT).**
- **GRANT OF SOFTWARE LICENSE.** This EULA grants you the following license:
  - You may use the SOFTWARE only on the DEVICE.
  - NOT FAULT TOLERANT. THE SOFTWARE IS NOT FAULT TOLERANT. Digital Electronics Corporation HAS INDEPENDENTLY DETERMINED HOW TO USE THE SOFTWARE IN THE DEVICE, AND MS HAS RELIED UPON Digital Electronics Corporation TO CONDUCT SUFFICIENT TESTING TO DETERMINE THAT THE SOFTWARE IS SUITABLE FOR SUCH USE.
  - NO WARRANTIES FOR THE SOFTWARE. THE SOFTWARE is provided "AS IS" and with all faults. THE ENTIRE RISK AS TO SATISFACTORY QUALITY, PERFORMANCE, ACCURACY, AND EFFORT (INCLUDING LACK OF NEGLIGENCE) IS WITH YOU. ALSO, THERE IS NO WARRANTY AGAINST INTERFERENCE WITH YOUR ENJOYMENT OF THE SOFTWARE OR AGAINST INFRINGEMENT. IF YOU HAVE RECEIVED ANY WARRANTIES REGARDING THE DEVICE OR THE SOFTWARE, THOSE WARRANTIES DO NOT ORIGINATE FROM, AND ARE NOT BINDING ON, MS.
  - Note on Java Support. The SOFTWARE may contain support for programs written in Java. Java technology is not fault tolerant and is not designed, manufactured, or intended for use or resale as online control equipment in hazardous environments requiring fail-safe performance, such as in the operation of nuclear facilities, aircraft navigation or communication systems, air traffic control, direct life support machines, or weapons systems, in which the failure of Java technology could lead directly to death, personal injury, or severe physical or environmental damage. Sun Microsystems, Inc. has contractually obligated MS to make this disclaimer.

- No Liability for Certain Damages. EXCEPT AS PROHIBITED BY LAW, MS SHALL HAVE NO LIABILITY FOR ANY INDIRECT, SPECIAL, CONSEQUENTIAL OR INCIDENTAL DAMAGES ARISING FROM OR IN CONNECTION WITH THE USE OR PERFORMANCE OF THE SOFTWARE. THIS LIMITATION SHALL APPLY EVEN IF ANY REMEDY FAILS OF ITS ESSENTIAL PURPOSE. IN NO EVENT SHALL MS BE LIABLE FOR ANY AMOUNT IN EXCESS OF U.S. TWO HUNDRED FIFTY DOLLARS (U.S.\$250.00).
- Limitations on Reverse Engineering, Decompilation, and Disassembly. You may not reverse engineer, decompile, or disassemble the SOFTWARE, except and only to the extent that such activity is expressly permitted by applicable law notwithstanding this limitation.
- SOFTWARE TRANSFER ALLOWED BUT WITH RESTRICTIONS. You may permanently transfer rights under this EULA only as part of a permanent sale or transfer of the Device, and only if the recipient agrees to this EULA. If the SOFTWARE is an upgrade, any transfer must also include all prior versions of the SOFTWARE.
- EXPORT RESTRICTIONS. You acknowledge that SOFTWARE is of US-origin. You agree to comply with all applicable international and national laws that apply to the SOFTWARE, including the U.S. Export Administration Regulations, as well as end-user, end-use and country destination restrictions issued by U.S. and other governments. For additional information on exporting the SOFTWARE, see <http://www.microsoft.com/exporting/>.
- LIMITATION ON SOFTWARE PROGRAMS USED ON THE DEVICE. The combination of software programs you use on the DEVICE shall address not more than two (2) general office automation or consumer computing functions. Such functions include, but are not limited to: e-mail, word processing, spreadsheets, database, network browsing, scheduling, and personal finance.
- Storage/Network Use. The SOFTWARE may not be installed, accessed, displayed, run, shared, or used concurrently on or from different computers, including a workstation, terminal, or other digital electronic device ("Computing System"). Notwithstanding the foregoing and except as otherwise provided below, any number of Computing Systems may access or otherwise utilize the file and print services and Internet information services of the SOFTWARE, if included.  
You may use the SOFTWARE on a single DEVICE as interactive workstation software, but not as server software. However, you may permit a maximum of ten (10) Computing Systems to connect to the DEVICE to access and use services of the SOFTWARE, such as file and print services and Internet information services. The ten-connection maximum includes any indirect connections made through other software or hardware which pools or aggregates connections.

IN-fINITY soft® Keyclick32

Digital Electronics Corporation shall be in no case liable for any loss or damages to you or any third party whatsoever arising from any faulty performance of IN-fINITY software, nor shall be responsible to correct such error of the software program in question.

## **DMC Corporation Mouse Emulation Software (TSC-1310D/DD) Software License Agreement**

Before unsealing and using this product, please read the following license agreement carefully:

This license agreement regarding the following software product (hereinafter called “product”) is concluded between you the individual or entity licensing the product (hereinafter called (“licensee”) and DMC Co., Ltd. (hereinafter called “DMC”). With unsealing, installing, copying or using the product, the licensee is regarded to agree this contract and the contract is in force. Please confirm and understand this agreement fully in advance. If you do not agree this contract, do not unseal, install, copy or use the software product at all. In such a case, please return the product at an unused state to the place you the licensee purchased it. Your payment will be returned to the licensee.

### **1. Copyright**

The copyright of the software product belongs to Touch-Base, Ltd.

### **2. License**

For the programs included in this product and the documents related to it, DMC grants untransferable nonexclusive license to licensee, which permits use of the product under the following conditions:

- (1) When a licensee does not purchase the license which permits the licensee to use a licensed product and its copy(s) and/or the license which permits use of the product on multiple computers, the licensee is granted the right to use the product on a single computer.
- (2) The licensee can create one copy of the product for archival purposes. For the other purposes, copying the whole or part of the product is strictly prohibited whichever medium you use.
- (3) The licensee shall display the copyright notice and other necessary information which is the same as that for the product on every copy of the product.
- (4) The intangible property right of the product and its copy(s) belong to DMC or the DMC supplier.

### **3. Term of use**

This contract shall maintain its validity from conclusion of the contract to the cancellation by DMC or the licensee.

### **4. Termination of the right of use**

- (1) The licensee can at any time terminate the right to use the product by expunging or destroying the product and all the copied contents.
- (2) When a licensee contravenes these license contents, DMC can notify the licensee of termination of the right to use the product. In this case, the licensee shall return the product or all the copied contents to DMC within one month.

## 5. Limited Warranty

- (1) DMC guarantees that 90 days after the licensee purchased the product, neither material nor manufacturing flaws shall be found at the medium where the product has been recorded or stored. If any errors related to the material or manufacturing is recognized when the product is installed, we shall replace the medium used to install the product on the condition that we are notified of it within the guaranteed period.
- (2) DMC shall grant the right to use the product at a state it has been supplied without explicit or implicit guarantee except for replacement of the medium containing product described in the above clause. Further, we do not guarantee that the product is suitable as useful for the licensee's specific purpose of use and that execution of the product is neither interrupted nor an error is found at its execution.
- (3) The responsibility attributable to DMC based on this agreement is limited to replacement of the medium containing the product, and DMC shall not assume any responsibility for the explicit or implicit guarantee including the other legal warranty against a defect and a liability for reparation given from a third party to the licensee regarding the licensee's profit loss caused by the product, damage arising from a special circumstance and the damage against data or intangible property right.

## 6. Licensee's obligation

The licensee shall recognize that the product shall possess the confidential information or property information including the intangible property right protected by the Copyright Act and shall not take the following actions:

- (1) Use and copying of the product against the terms of the license and disassembling, reverse engineering, and modifying the product.
- (2) Deletion and/or change of display of the intangible property right including the copyright displayed on the medium containing the product.

## 7. Restrictions on Export

When the product is subjected to the regulation of the Foreign Exchange and Foreign Trade Control Act and the laws and regulations accompanying it and the Export, the licensee shall observe the corresponding laws and regulations and rules.



<http://www.dmccoltd.com>

Hironokougyoudanchi, Hirono-machi, Futaba-gun, Fukushima  
979-0401, Japan

Phone: +81-240-27-4030 Fax: +81-240-27-4025

# PowerQuest® Corporation's EasyRestore™

## End User License Agreement

The following license agreement displays when an end user uses the EasyRestore system recovery software.

**IMPORTANT:** Read this before using your copy of PowerQuest software.

This document is a legal agreement between you, the "end user," and PowerQuest Corporation.

Use of the software indicates your acceptance of these terms. As used in this License Agreement, the term "Software" means the EasyRestore software included on the CD provided with this License Agreement.

1. **PROPRIETARY RIGHTS.** The Software is a proprietary product of PowerQuest Corporation ("PowerQuest") or its licensors and is protected under U.S. copyright laws and international treaty provisions. Ownership of the Software and all copies, modifications, and merged portions thereof shall at all times remain with PowerQuest or its licensors.
2. **GRANT OF LICENSE.** The Software is being licensed to you, which means you have the right to use the Software only in accordance with this License Agreement. The Software contains pre-installed software for disaster recovery purposes. The Software is only authorized for distribution together with a specific computer. This License authorizes you to use the Software for disaster recovery purposes only, to restore the hard disk image contained on the CD to the computer with which the CD and Software were originally shipped.
3. **NONPERMITTED USES.** Without the express permission of PowerQuest, you may not (a) use, copy, modify, alter, or transfer, electronically or otherwise, the Software or documentation except as expressly permitted in this License Agreement, or (b) translate, reverse program, disassemble, decompile, or otherwise reverse engineer the Software.
4. **TECHNICAL SUPPORT.** PowerQuest is NOT responsible to provide technical support. Any and all technical support questions regarding the Software should be referred to the place of purchase.
5. **U.S. GOVERNMENT RESTRICTED RIGHTS.** If you are acquiring the Software on behalf of any unit or agency of the United States Government, the following provision applies: It is acknowledged that the Software and the documentation were developed at private expense and that no part is in the public domain and that the Software and documentation are provided with RESTRICTED RIGHTS. Use, duplication, or disclosure by the Government is subject to restrictions as set forth in subparagraph (c)(1)(ii) of the Rights in Technical Data and Computer Software clause at DFARS 252.227-7013 or subparagraphs (c)(1) and (2) of the Commercial Computer Software-Restricted Rights at 48 CFR 52.227-19, as applicable. Contractor/manufacturer is PowerQuest Corporation/P.O. Box 1911/Orem, UT 84059.

6. NO WARRANTY. The Software is being provided to you AS IS.

PowerQuest does not warrant the Software to end users. If the Software fails to perform substantially in accordance with the documentation provided to your hardware supplier, PowerQuest will repair or replace the copy of the Software provided to your hardware supplier and will authorize your hardware supplier to provide such repaired or replaced Software to you without charge.

7. LIMITATION OF LIABILITY. NEITHER POWERQUEST NOR ITS SUPPLIERS SHALL IN ANY EVENT BE LIABLE FOR ANY DAMAGES WHATSOEVER ARISING OUT OF OR RELATED TO THE USE OF OR INABILITY TO USE THE SOFTWARE, INCLUDING BUT NOT LIMITED TO DIRECT, INDIRECT, SPECIAL, INCIDENTAL, OR CONSEQUENTIAL DAMAGES, AND DAMAGES FOR LOSS OF BUSINESS PROFITS, BUSINESS INTERRUPTION, LOSS OF BUSINESS INFORMATION, OR OTHER PECUNIARY LOSS, EVEN IF POWERQUEST CORPORATION HAS BEEN ADVISED OF THE POSSIBILITY OF SUCH DAMAGES, WHETHER SUCH LIABILITY IS BASED ON CONTRACT, TORT, WARRANTY, OR ANY OTHER LEGAL OR EQUITABLE GROUNDS. BECAUSE SOME STATES DO NOT ALLOW THE EXCLUSION OR LIMITATION OF LIABILITY FOR CONSEQUENTIAL OR INCIDENTAL DAMAGES, THE ABOVE LIMITATION MAY NOT APPLY TO YOU.

This License Agreement constitutes the entire agreement between you and PowerQuest pertaining to its subject matter. This License Agreement is governed by the laws of the State of Utah. Any litigation arising from this license will be pursued only in the state or federal courts located in the State of Utah.

Should you have any questions concerning this Agreement, or if you desire to contact PowerQuest Corporation for any reason, write: PowerQuest Corporation, P.O. Box 1911, Orem, Utah 84059 U.S.A.

©1994-2001 PowerQuest Corporation. All rights reserved. The Software may be protected by U.S. patents, with other patents pending in the U.S.A. and elsewhere. PowerQuest is a registered trademark and EasyRestore is a trademark of PowerQuest Corporation.

# Safety Cautions



## WARNINGS

- **Be sure to check that the PL's power is disconnected before installing the unit, in order to prevent an electrical shock.**
- **Do not attempt to modify or open the HDD unit, since it can cause a shock or fire.**
- **When installing the HDD unit, be sure to read the following "2. Installation" section's information completely to insure that the unit is correctly installed.**

### To Prevent Accidents

- Since the HDD unit is a precision instrument, be sure it is neither hit by nor pressed strongly against another object. After unpacking, be sure the unit is not dropped or jolted during installation. Also, a PL built in to a larger unit (i.e. operation panel) should be removed and packed separately prior to shipping.
- Be sure water, liquids or metal particles are not allowed to enter the HDD unit. Any of these may cause either a breakdown or an electrical shock.
- Do not place or store this unit in a location where there is direct sunlight, excessive heat, dust or vibration.
- Do not store or operate this unit near chemicals, or where there are chemical fumes.
- Do not allow anyone other than Pro-face's own service staff to perform maintenance or adjustments to this unit.
- Do not move or shift the PL while the HDD unit is installed and the PL unit's power is ON.
- Do not use the HDD unit in locations where corrosive gasses are present, since they can lead to a hard disk breakdown.
- To prevent damage to file data, be sure to shut down the PL unit's OS before turning OFF the main power.
- To prevent HDD memory leaks, restart the OS periodically.
- In order to extend the lifetime of the hard disk, Pro-face recommends you set the Windows [Control panel]-[Power Management option]-[Turn off hard disks] selection to turn the hard disk off when the unit is not being operated. A setting of 5 minutes is recommended.



# Package Contents

Please check that the following items are all included in your package.

- Windows® 2000 Multi Language Preinstalled HDD unit
- Recovery Media CD-ROM (2)

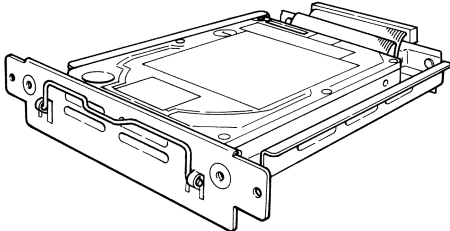

- Installation Guide



Pro-face has taken the utmost care to ensure the quality of this product when it was shipped, however, should, for any reason, problems or damage have occurred during shipping, please contact your Pro-face representative immediately for service.

## 1 Hardware Specifications

### ■ Features

Capacity	20GB
Average Seek Time	12msec(TYP)
Power Consumption	At Startup : 4.7W (MAX)
	Read/Write : 2.0/2.1W (TYP)
	During Wait : 0.65W(TYP)
Interface	ATA
Operation Lifetime	5 years, or 20,000 operating hours, whichever comes first



- This HDD unit has a finite usage lifetime. Therefore, be sure to back up all HDD data regularly and/or prepare a backup HDD unit.
- The HDD unit's lifetime will vary, depending on the usage conditions and environment. The above value is calculated assuming an ambient temperature of 20°C and 333 hours of operation per month. (HDD access frequency of 20% or less)

## ■ Environment

<b>Operating Temperature</b>	5°C to 50°C
<b>Storage Temperature</b>	-10°C to +60°C
<b>Ambient Humidity</b>	10%RH to 85%RH (no condensation) Wet bulb temperature: 29°C or less
<b>Noise Resistance</b> (via Noise Simulator)	Noise Voltage: 1500Vp-p Pulse Width: 50ns, 500ns, 1μs
<b>Electrostatic Discharge Immunity</b>	6kV
<b>Vibration Resistance</b>	4.9m/s <sup>2</sup> (10Hz to 25Hz) (When Operating)
<b>Shock Resistance</b> <sup>*1</sup>	3920m/s <sup>2</sup> (1ms, Half-sine shock pulse)

\*1 In factory-packed condition.



- The environment specifications given here are for a unit installed in a PL, that is built into a solid panel.
- Pro-face does not guarantee the preservation of any data stored on the HDD unit if the HDD unit has an accident, malfunctions or is damaged in any way. Therefore, the regular backing up of important HDD unit data to either a floppy disk, or other type of suitable magnetic media is strongly recommended.
- This HDD unit has a finite usage lifetime. The lifetime figure given in this document's Features is for reference, and the regular exchanging of the current HDD unit for a new HDD unit is strongly advised.
- Using the HDD unit in an environment that is excessively hot and/or humid will shorten the disk's usage lifetime. A wet bulb temperature of 29°C or less is recommended. This is equivalent to the following data.

Temperature	Humidity
at 35°C	no higher than 64%
at 40°C	no higher than 44%

- In order to extend the lifetime of the hard disk, Pro-face recommends you set the Windows [Control panel]-[Power Management option]-[Turn off hard disks] selection to turn the hard disk off when the unit is not being operated. A setting of 5 minutes is recommended.

## 2 Installation

Use the following steps to install the HDD unit in the PL.



### WARNING

**Shock Danger! Be sure to unplug the PL unit from its power supply prior to installing the HDD unit.**



Since the HDD unit is a precision instrument that has a low resistance to shocks, be sure it is neither hit by nor pressed strongly against another object when installing it.

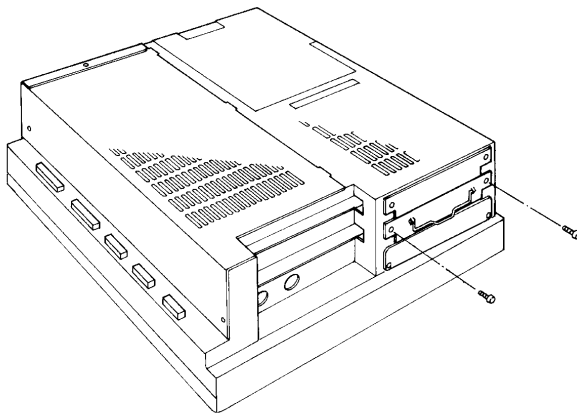

- 1) Unscrew the expansion slot's two (2) blank panel screws, and remove the blank panel.

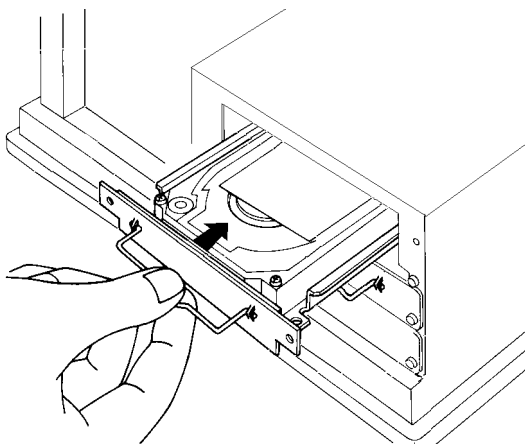
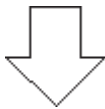

- 2) Hold the HDD unit's removal handle and slide the unit slowly into the expansion slot, until the rear face connector is completely inserted into the slot's connector pins.

- 3) Reattach the two (2) expansion slot cover attachment screws.



**Note:** When installing an HDD unit in other Expansion Slots, use the above installation procedures.

### 3

## Hardware Setup

The HDD unit's installation and system data settings are as follows.

- 1) Install the HDD unit in the PL. Refer to **2 Installation** for details. If the HDD unit is already installed, this step is not necessary.
- 2) Connect a keyboard to the PL.
- 3) Turn on the PL unit's power supply and use the following steps to set up the system data and recognize the HDD unit.



- Normally, use the factory (initial) settings.
- Your PL unit's system data screen menus may differ slightly from these due to installation of newer software.
- The following explanation uses the PL unit's factory settings.

- 4) When the "Press <DEL> to enter SETUP" message appears, press your PC's DEL key.

The Setup utility will start. Select the [Standard CMOS Features] and the following screen will appear.

CMOS Setup Utility - Copyright (C) 1984-2001 Award Software	
IDE Primary Master	
IDE HDD Auto-Detection [Press Enter]	Item Help
IDE Primary Slave [Auto]	Menu Level ▶▶
Access Mode [Auto]	To auto-detect the HDD's size, head.... on this channel
Capacity 0 MB	
Cylinder 0	
Head 0	
Precomp 0	
Landing Zone 0	
Sector 0	
↑↓→←: Move Enter:Select +/-PU/PD:Value F10:Save ESC:Exit F1:General Help	
F5:Previous Values F6:Fail-Safe Defaults F7:Optimized Defaults	

- 5) Confirm whether "AUTO" is selected in the Master screens. If AUTO is selected in both, disk parameters will be automatically read when the PL is turned ON. If AUTO is not selected, change these settings to AUTO. The factory setting is AUTO and recommended for most users. (When using together with HDD unit.)
- 6) After changing all settings, press the ESC key and select [Save & EXIT Setup] to save the settings. The OS will then start.

## OS Setup

### ■ Software Design

Your Windows® 2000 Multi Language preinstalled hard disk unit contains the following software.

- Microsoft corporation's Windows® 2000 Professional OS
- DMC corporation Mouse Emulation Software (TSC-1310D/DD)
- Keyboard Emulator Keyclick32
- Pro-face's PL utility software and drivers

### ■ Windows® 2000 Setup Procedure



**Note:** A detailed explanation of the software, as well as a list of the revisions made after the printing of this document can be found in the HDD unit and the Recovery CD-ROM's README.txt files.

- 1) Once the PS-B unit's power is turned ON, this HDD unit's [Windows 2000 Professional Setup] screen, and then the [Welcome to the Windows 2000 Setup Wizard] will appear. Click on [Next].
- 2) The [License Agreement] screen will appear.  
After reading the contents, press [I accept this agreement] if you agree, and click [Next] to continue.
- 3) The [Regional Settings] screen will appear.  
After entering the data for your area, click [Next] to continue.
- 4) The [Personalize Your Software] screen will appear  
After entering your name [Name] and [Organization], click on [Next] to continue.
- 5) The [Your Product Key] screen will appear.  
After entering the product key data, click on [Next] to continue.
- 6) The [Computer Name and Administrator Password] screen will appear.  
Enter the [Computer Name and Administrator Password], and [Confirm Password], then click [Next] to continue.  
When entering the [Computer Name], if the name shown on the display is not correct, you can enter another name. When the computer is connected to a network, be sure to ask your network manager what is the correct name for this field.
- 7) The [Date and Time Settings] screen will appear.  
After entering these settings, select [Next] to continue.
- 8) [Network Settings] screen will appear.  
Choose whether to use typical or custom settings depending on your PC circumstance.
- 9) [Workgroup or Computer Domain] screen will appear.  
Choose wheter to make your PC on a network or not depending on your PC circumstance.

- 10) [Performing Final Tasks] is automatically done by the PS-B.  
 The [Completing the Windows 2000 Setup Wizard] will appear.  
 Press [Finish] and the system will automatically restart.
- 11) When the [Network Identification Wizard] screen and the [Welcome to the Network Identification Wizard] is started, please press [Next]. The [Users of This Computer] screen will appear. After entering the desired settings, press [Next] and then press the [Finish] button.
- 12) The [Selection of a Display] screen will appear.  
 Select the PL Series name you are using and the display size will be adjusted.  
 The system will automatically restart, now you can use the Windows® 2000.

## 5 Multi Language

The Windows® 2000 Multi Language Preinstalled Hard Disk Unit contains the following languages;

Chinese (Simplified)	English	Hungarian	Russian
Chinese (Traditional)	Finnish	Italian	Spanish
Czech	French	Polish	Swedish
Danish	German	Portuguese (Brazil)	Turkish
Dutch	Greek	Portuguese (Portugal)	

### ■ Designating the Language

- 1) Select the Windows® 2000 [Start] menu's [Settings], then [Control Panel] command.
- 2) Select the [Regional Options] command.
- 3) Select the appropriate language from "Menu and dialogs:" in the "General" tab.

## 6

# HDD Recovery Procedure



- **After performing hard disk recovery, the PL unit's hard disk is returned to its factory shipped condition.**
- **A USB-type CD-ROM drive cannot be used to start the Recovery CD. Be sure to use Digital's CD-ROM drive unit (PL-DK200/PSS-CD01).**

Use the following steps used to recover the Windows® 2000 Multi-Language Preinstalled Hard Disk.

1. Insert the Recovery CD's Disk 1 into the CD-ROM drive and turn the PL unit's power ON. Immediately after the power turns ON, press the [Del] key. The unit's BIOS setup screen will appear.
2. Select the Setup Utility Advanced BIOS Features' First Boot Device's CD-ROM setting.
3. Press the [F10] key to save the setting and restart the unit.
4. After the unit restarts, the EasyRestore™ program will automatically start.
5. After the EasyRestore™ program starts, Press the [Continue] button.
6. When the Warning screen's "You are about to destroy all of the data on drive1. Are you sure you want to continue?" message appears, click [Yes].
7. The previously inserted Disk 1's hard disk recovery program will start. When the message "Insert media2" appears, insert Recovery CD Disk2 and press the [Enter] key.
8. When CD Disk2's operation finishes, recovery is completed. Next, the Reboot dialog box will appear. Click on "Reboot" and the unit will restart.
9. During the restart, press the [Del] key to enter the BIOS Setup mode.
10. In the Setup screen, set Load Optimized Defaults to reset all BIOS settings to their original values. Next, press [F10] key to save the settings and restart the unit.
11. After the unit restarts, set up your OS as desired.

▼ **Reference** ▲ *4 OS Setup*



- **If the hard disk unit breaks down due to a hardware problem, (Ex. if BIOS cannot find the hard disk, if the hard disk's lifetime expires, or it breaks down), EasyRestore cannot recover the hard disk. Pro-face recommends that in this case you contact your local PS-B distributor for instructions about hard disk recovery or replacement.**
- **Pro-face does not guarantee the preservation of any data stored on the HDD unit if the HDD unit has an accident, malfunctions or is damaged in any way. Therefore, the regular backing up of important HDD unit data to either floppy disks, or other type of suitable magnetic media is strongly recommended.**

▼ **Reference** ▲ *1 Hardware Specifications*

# 7

## When using PL-B920 Series Unit

The connection method used can be via either a serial or USB interface. Also, the type of OS and Touch Panel Device Driver (mouse emulator) used will depend on the type of connection method used for the display and for the touch panel.

Display Type	Touch Panel Connection	Touch Panel Device Driver (Mouse Emulator)
PL-DU6900 PL-DU7900	Serial (RS-422)	U-TP (Gunze Inc.) <sup>*1 *2</sup>
	USB	USB Touch Panel Device Driver <sup>*2</sup> (included with DU)
FP-2500 FP-2600	Serial (RS-232C)	Perform calibration
	USB	<sup>*3</sup>
FP-790	Serial (RS-232C)	U-TP (Gunze Inc.) <sup>*1 *2</sup>

\*1 For product details, please contact your local PL distributor or representative.

\*2 Use the [Control Panel] area's [Add/Remove Programs] feature to remove the [Universal Pointer Device Driver]. Then, install the [Touch Panel Device Driver].

\*3 Use the [Control Panel] area's [Add/Remove Programs] feature to remove the [Universal Pointer Device Driver].

Use the "RUN" feature to start up the [C:\Proface\Updd\Setup.exe] file. When the list of drivers appears, select "Digital.TSC-1310D Series.USB" and follow the instructions given to complete the driver installation.

When the connection method is changed to USB, the following BIOS level System settings must also be changed.

**Reference** *BOX-Type Industrial Computer PL-B920 Series User Manual*  
Chapter 5 - System Setup

System Setting Menu	Setting Item	USB Setting
Integrated Peripherals	USB Controller	Enabled
	Onboard Serial Port 4	Disabled
PnP/PCI Configuration	Assign IRQ For USB	Enabled

When the DU display unit is used, the PL's dip switch settings must also be changed. For details,

**Reference** *BOX-Type Industrial Computer PL-B920 Series User Manual*  
2.4 PL Part Names and Features

### Note

Please be aware that Digital Electronics Corporation shall not be held liable by the user for any damages, losses, or third party claims arising from the uses of this product.

Digital Electronics Corporation

8-2-52 Nanko Higashi, Suminoe-ku, Osaka

559-0031, Japan

URL : <http://www.pro-face.com/>

© 2004 Digital Electronics Corporation All rights reserved.

060698G

.PL-HDX920-W2K-MULTI-MM03

2004.5

JM/A