

PL-FD210

Installation Guide

The PL-FD210 (FDD Unit) is an internally mounted 3.5 inch floppy disc drive unit, designed for use with Proface's Panel Computer, hereafter referred to as the "PL."

Corresponding PL unit: PL-X900 Series Units(4Slot type), PL-X920 Series Units (4-Slot type)

All product names used in this document are the trademarks of their respective manufacturers.

Pro-face: Digital Electronics Corporation



Warning - Safety Precautions

- Be sure to confirm that the PL unit's power cord is disconnected prior to installing PL-FD210, in order to prevent electrical shock.
- Do not attempt to modify the PL-FD210, due to the danger of fire or electrical shock.
- Prior to installing the PL-FD210, be sure to read this Installations Guides' "2. Installation" section completely to insure that this unit is correctly installed.

To Prevent Accidents

- Since the PL-FD210 is a precision instrument, be sure that it is neither hit by nor pressed strongly against another object.
- Be sure that water, liquids, or metal particles are not allowed to contact or enter this unit. Either of these may cause either a breakdown or an electrical shock.
- Do not install or operate this unit in a location where there is direct sunlight, excessive heat, dust or vibration.
- Do not store or operate this unit near chemicals, or where there are chemical fumes.
- Do not use the PL-FD210 in locations where corrosive gasses are present.
- To prevent damage to file data, be sure to shut down the unit's OS before turning OFF the main power.

Package Contents

When you open the PL-FD210's package, please check immediately that the following items are included.

■ **PL-FD210 (1)**

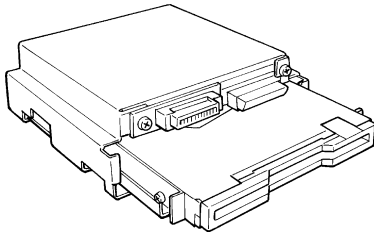

■ **Installation Guide (1)**
(PL-FD210)



■ **Attachment Screws (2)**

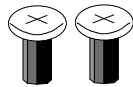

Pro-face has taken the utmost care to insure the quality of this product when it was shipped. However, should, for any reason, problems or damage have occurred during shipping, please contact your Pro-face representative immediately for service.

1 Hardware Specifications

■ **Performance**

Operation mode	2MB mode record/write	1MB mode record/write
Disc Type (3.5 inch)	high density type (2HD)	double density type (2DD)
Unformatted data capacity	2M bytes	1M bytes
Data Transmission speed	500k bits/second	250k bits/second
Disc rotation speed	300 rpm	
Track density	135 tpi	
Track-track seek speed	3 ms	
Power consumption	At start: 0.7A (typ.) At read/write: 0.3A (typ.) During wait: 0.01A (typ.)	
Reliability (MTBF)	30,000 hours	

■ Environment

Ambient operating temperature	5 ⁰ C to 50 ⁰ C
Ambient storage temperature	-10 ⁰ C to +60 ⁰ C
Ambient humidity	20%RH to 80%RH (no condensation)
Vibration resistance	(During operation) 9.8m/s ² (10Hz to 25Hz)
Shock resistance	(During shipping) 980.7m/s ²



- ***The above specifications are for the PL-FD210 unit only.***
- ***The Pro-face does not guarantee the preservation of any data stored on the PL-FD210 if the PL-FD210 has an accident, malfunctions or is damaged in any way. Therefore, the regular backing up of important HDD data to either a floppy disk, or other type of magnetic media is strongly recommended.***

2 Installation

Be sure to use the following installation procedures to insure that the unit is correctly installed.



WARNING

Shock Danger! Be sure to disconnect the PL unit's power cord prior to installing the PL-FD210.



- *The PL-FD210 can only be installed in the PL-X900/X920 Series 4-slot unit.*
- *The PL-FD210 and FD-200 cannot be used at the same time.*

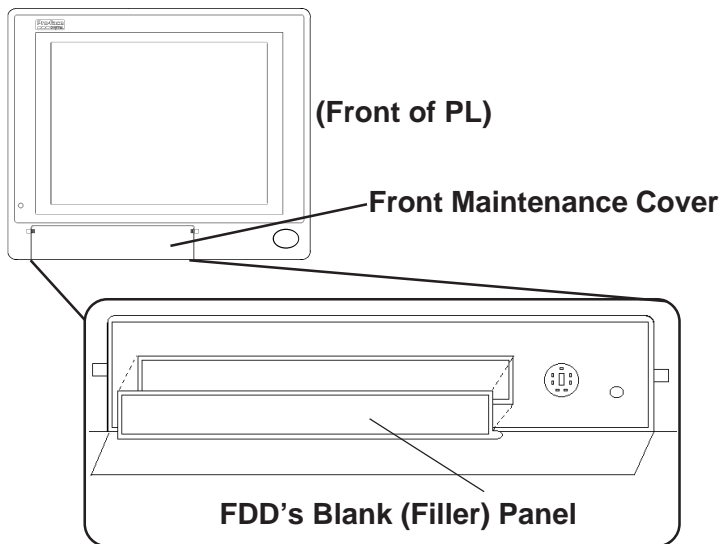

1) Open the PL unit's front face maintenance cover and remove the FDD's blank (filler) panel.

2) Close the front maintenance cover.

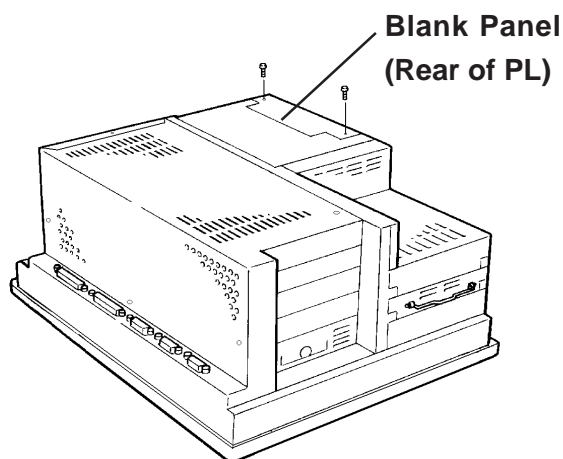

3) Unscrew the two attachment screws from the PL unit's rear face Blank Panel, and remove the cover.



Note: When attaching this unit to a PL-7900/7920 Series unit, steps 4 and 5 are not required. Please continue from step 6.

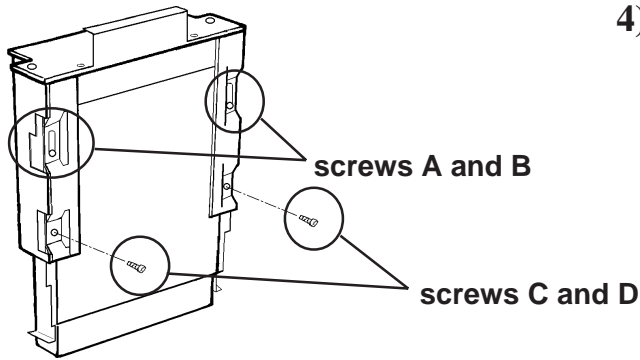

- 4) Loosen the PL-FD210 unit's two (2) upper adjustment screws (screws A and B), and remove the two (2) lower set screws (screws C and D).

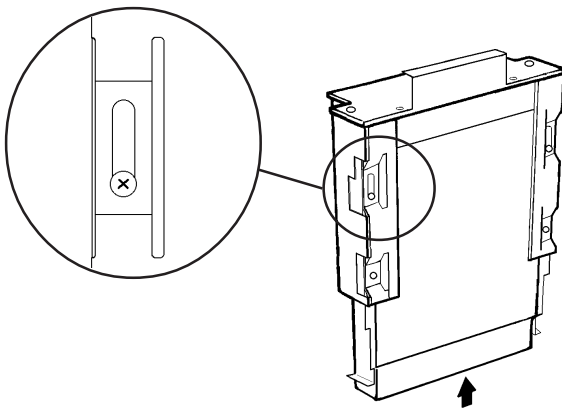

- 5) Slide the unit in the direction shown by the arrow, until the lower set screws' screw hole appears. Re-insert the two (2) lower set screws, and tighten both upper and lower (4) screws.

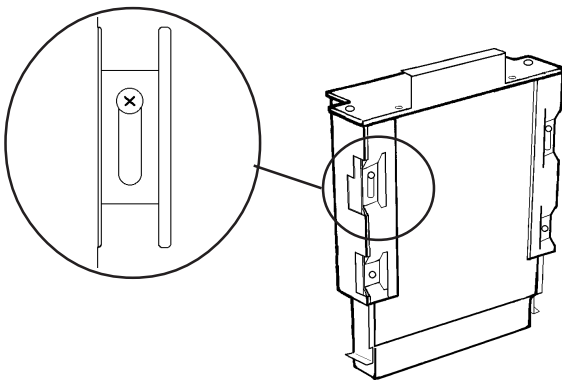

- 6) Insert the FDD unit so that its guide grooves fit the chassis guide ways. Push the unit in until its rear connector is connected securely.

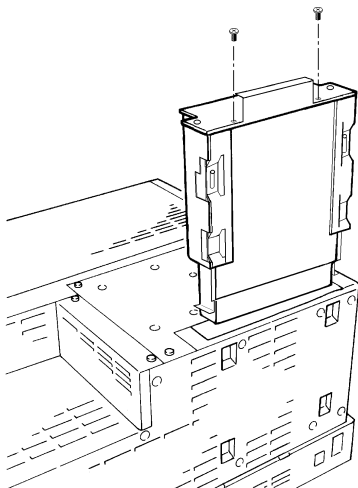

- 7) Fix the unit in place with its two (2) attachment screws.

- 8) Last, re-attach the rearface Blank Panel removed in step 3).

3 Hardware Setup

- 1) Connect a keyboard to the PL.
- 2) Turn the PL's power ON.
- 3) After the message, "Press to Enter SETUP" appears at the left bottom of the screen, hold down the [DEL] key.

The setup utility will start and the following screen will appear.

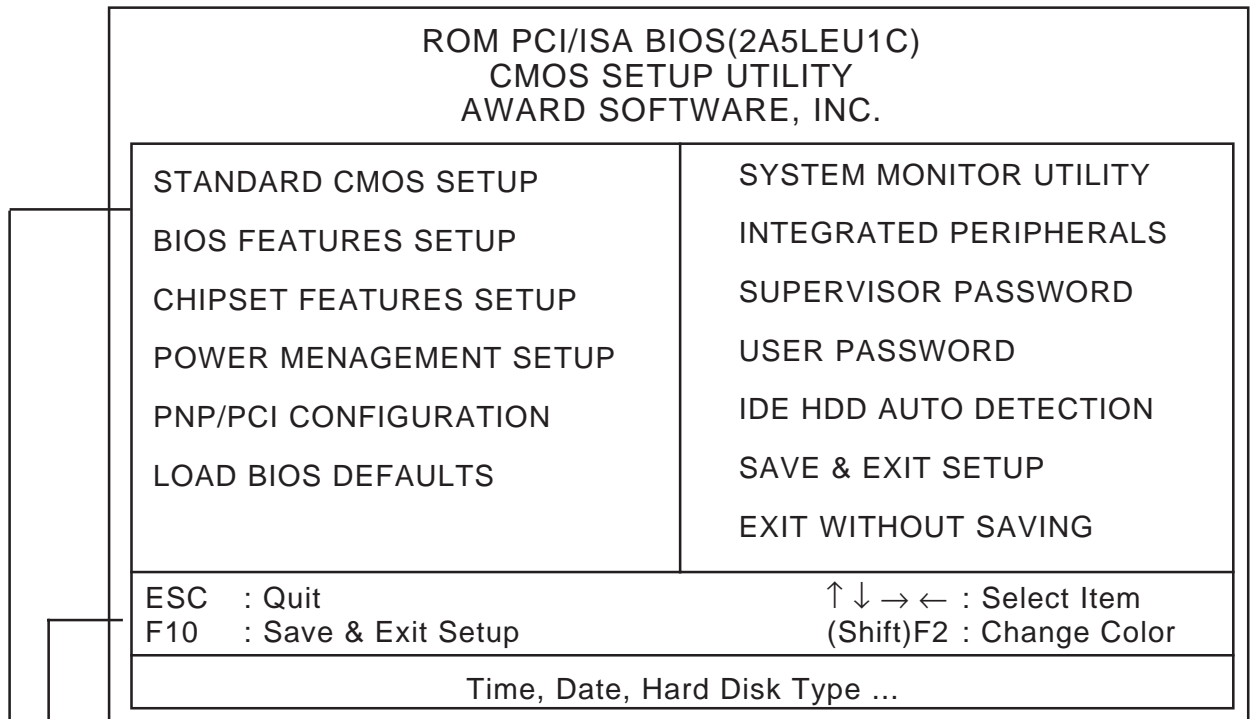

Operation Keys

Provides a list of keys used for setup procedures.

System Setting Areas

Each selection item shown here represents a separate menu area, where settings can be entered.

- 4) Use the cursor to select "STANDARD CMOS SETUP," and the following screen will appear.

ROM PCI/ISA BIOS(2A5LEU1C)
STANDARD CMOS SETUP
AWARD SOFTWARE, INC.

Date (mm:dd:yy): Wed, Jul 2 1998

Time (hh:mm:ss): 14 : 50 : 3

	CYLS.	HEADS	PRECOMPL	ANDZONE	SECTORS	MODE
Drive C AUTO	: Auto(0b)	0	0	0	0	0
Drive D AUTO	: Auto(0b)	0	0	0	0	0

Drive A : 1.44M, 3.5 in.

Video : EGA/VGA
VGA Text Mode:Normal
VGA Graphics Mode:Normal

Halt On : All, But Keyboard

Base Memory	:	640K	
Extended Memory	:	31744K	
Other Memory	:	384K	
Total Memory		:	32768K

ESC : Quit ↑↓→←: Select Item PU/PD/+/- : Modify
F1 : Help (Shift)F2: Change Color

- 5) Confirm that “Drive A:” is set to “1.44M, 3.5 in.” If the setting is different, Place the cursor on the “Drive A:” selection item and use the [PU], [PD] or [+], [-] key to select the “1.44M, 3.5 in.” drive setting.
- 6) Press the [ESC] key, and the initial (main) menu screen will appear.
- 7) Place the cursor on the “SAVE & EXIT SETUP” selection item and press the [Enter] key.
- 8) After “SAVE to CMOS and EXIT (Y/N)? N” appears, press the [Y] key to quit the setup utility.

Note

Be aware that the Digital Electronics Corporation shall not be held liable for any real or estimated damages or losses, or third party claims resulting from the use of this product.

Digital Electronics Corporation

8-2-52 Nanko Higashi, Suminoe-ku, Osaka 559-0031, Japan

URL: <http://www.pro-face.com/>