

PL-FD200

Installation Guide

The PL-FD200 (FDD Unit) is an internally mounted 3.5 inch floppy disc drive unit, designed for use with Pro-face's Panel Computer, hereafter referred to as the "PL."

Corresponding PL unit: PL-X900, PL-X920 Series Units

All product names used in this document are the trademarks of their respective manufacturers.

Pro-face: Digital Electronics Corporation



Warning - Safety Precautions

- Be sure to confirm that the PL unit's power cord is disconnected prior to installing PL-FD200, in order to prevent electrical shock.
- Do not attempt to modify the PL-FD200, due to the danger of fire or electrical shock.
- Prior to installing the PL-FD200, be sure to read this Installation Guide's "2. Installation" section completely to ensure that this unit is correctly installed.

To Prevent Accidents

- Since the PL-FD200 is a precision instrument, be sure that it is neither hit by nor pressed strongly against another object.
- Be sure that water, liquids, or metal particles are not allowed to contact or enter this unit. Either of these may cause either a breakdown or an electrical shock.
- Do not install or operate this unit in a location where there is direct sunlight, excessive heat, dust or vibration.
- Do not store or operate this unit near chemicals, or where there are chemical fumes.
- Do not use the PL-FD200 in locations where corrosive gasses are present
- To prevent damage to file data, be sure to shut down the PL unit's OS before turning OFF the main power.

Package Contents

When you open the PL-FD200's package, please check immediately that the following items are included.

■ **PL-FD200**

(1)

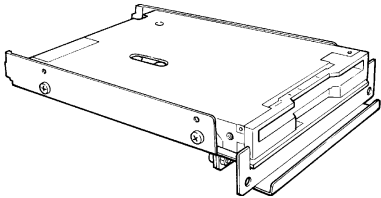

■ **Installation Guide**

(1)

(PL-FD200)



Pro-face has taken the utmost care to insure the quality of this product when it was shipped. However, should, for any reason, problems or damage have occurred during shipping, please contact your local Pro-face representative immediately for service.

1

Hardware Specifications

■ Performance

Operation Mode	2MB mode record/write	1MB mode record/write
Disc Type (3.5 inch)	high density type (2HD)	double density type (2DD)
Unformatted Data Capacity	2M bytes	1M bytes
Data Transmission speed	500k bits/second	250k bits/second
Disc Rotation Speed	300 rpm	
Track Density	135 tpi	
Track-track Seek Speed	3 ms	
Power Consumption	At start: 0.7A (typ.) At read/write: 0.3A (typ.) During wait: 0.01A (typ.)	
MTBF(Mean Time Between Failures)	30,000 hours	

■ Environment

Ambient Operating Temperature	5 ⁰ C to 50 ⁰ C
Ambient Storage Temperature	-10 ⁰ C to +60 ⁰ C
Ambient Humidity	20% to 80%RH (no condensation)
Vibration Resistance	(During operation) 9.8m/s ² (10Hz to 25Hz)
Shock Resistance	(During shipping) 980.7m/s ²



- ***The above specifications are for the PL-FD210 unit only.***
- ***Pro-face does not guarantee the preservation of any data stored on the PL-FD210 if the PL-FD210 has an accident, malfunctions or is damaged in any way. Therefore, the regular backing up of important HDD data to either a floppy disk, or other type of magnetic media is strongly recommended.***

2 Installation

Be sure to use the following installation procedures to insure that the unit is correctly installed.



WARNING

WARNING: Shock Danger! Be sure to disconnect the PL unit's power cord prior to installing the PL-FD200.

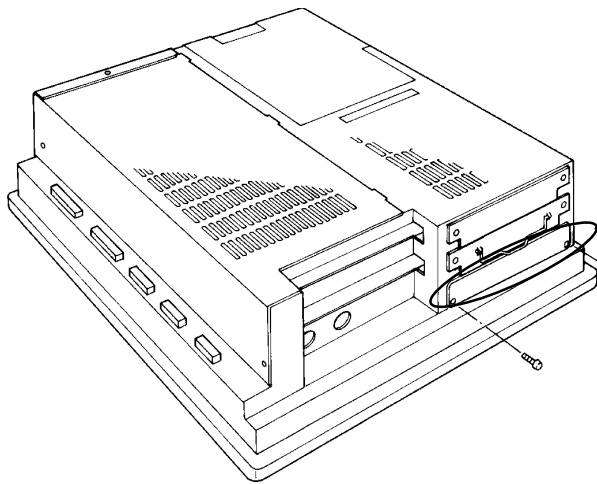

- 1) Remove the lowermost of the PL's blank panels (located on the PL's side face) by unscrewing that panel's two(2) attachment screws. Then, remove the blank panel.

Note: This slot is reserved for the PL-FD200 unit. Do not insert this unit into any other slot.

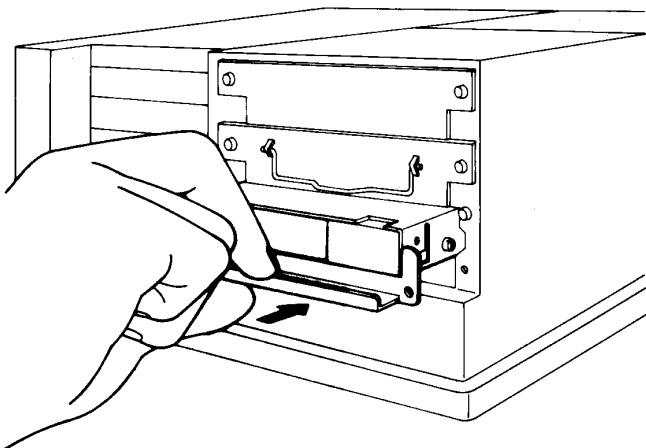
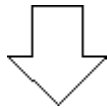

- 2) Insert the FDD unit into its installation slot, along the inside guide rail, until the FDD unit's connector contacts the rear connector receptacle and is inserted securely in place.
- 3) Reattach the panel attachment screws removed in step 1) and tighten them securely.

3 Hardware Setup

- 1) Connect a keyboard to the PL.
- 2) Turn the PL's power ON.
- 3) After the message, "Press to Enter SETUP" appears at the left bottom of the screen, hold down the [DEL] key.

The setup utility will start and the following screen will appear.

ROM PCI/ISA BIOS(2A5LEU1C) CMOS SETUP UTILITY AWARD SOFTWARE, INC.	
STANDARD CMOS SETUP BIOS FEATURES SETUP CHIPSET FEATURES SETUP POWER MENAGEMENT SETUP PNP/PCI CONFIGURATION LOAD BIOS DEFAULTS LOAD SETUP DEFAULTS	SYSTEM MONITOR UTILITY INTEGRATED PERIPHERALS SUPERVISOR PASSWORD USER PASSWORD IDE HDD AUTO DETECTION SAVE & EXIT SETUP EXIT WITHOUT SAVING
ESC : Quit	↑ ↓ → ← : Select Item
F10 : Save & Exit Setup	(Shift)F2 : Change Color
Time, Date, Hard Disk Type ...	

Operation Keys

Provides a list of keys used for setup procedures.

System Setting Areas

Each selection item shown here represents a separate menu area, where settings can be entered.

- 4) Use the cursor to select "STANDARD CMOS SETUP," and the following screen will appear.

ROM PCI/ISA BIOS(2A5LEU1C)
STANDARD CMOS SETUP
AWARD SOFTWARE, INC.

Date (mm:dd:yy): Wed, Jul 2 1998

Time (hh:mm:ss): 14 : 50 : 3

	CYLS.	HEADS	PRECOMP	LANDZONE	SECTORS	MODE
Drive C: Auto(0b)	0	0	0	0	0	AUTO
Drive D: Auto(0b)	0	0	0	0	0	AUTO

Drive A : 1.44M, 3.5 in.

Video: EGA/VGA
VGA Graphics Mode: Normal

Base Memory	:	640K
Extended Memory	:	31744K
Other Memory	:	384K
<hr/>		
Total Memory	:	32768K

Halt On : All, But Keyboard

ESC : Quit ↑↓→← : Select Item PU/PD/+/- : Modify
F1 : Help (Shift)F2 : Change Color

- 5) Check if the “Drive A:” is designated as “1.44M, 3.5 in.” If not, place the cursor on the “Drive A:” selection and use the [PU], [PD] or [+], [-] key to select the “1.44M, 3.5 in.” drive setting.
- 6) Press the [ESC] key, and the initial (main) menu screen will appear.
- 7) Place the cursor on the “SAVE & EXIT SETUP” selection item and press the [Enter] key.
- 8) After “SAVE to CMOS and EXIT (Y/N)? N” appears, press the [Y] key to quit the setup utility.

Note

Please be aware that Digital Electronics Corporation shall not be held liable by the user for any damages, losses, or third party claims arising from the uses of this product.

Digital Electronics Corporation

8-2-52 Nanko Higashi, Suminoe-ku, Osaka 559-0031, Japan

URL: <http://www.pro-face.com/>

© Copyright 1998 Digital Electronics Corporation All rights reserved.