

PL-B920 Series Standard Display  
PL-DU6900/PL-DU7900  
User Manual

# Preface

---

Thank you for purchasing Pro-face's PL-B920 Series Standard Display PL-DU6900/PL-DU7900 (hereafter referred to as "the DU").

The DU unit uses the most up-to-date, cost-effective, high-performance architecture and is designed exclusively for use with Pro-face's BOX-Type Industrial Computers (hereafter referred to as "the PL").

Please read this manual carefully as it explains, step by step, how to use the DU correctly and safely.

- 1) It is forbidden to copy the contents of this manual, in whole or in part, except for the user's personal use, without the express permission of the Digital Electronics Corporation of Japan.
- 2) The information provided in this manual is subject to change without notice.
- 3) This manual has been written with care and attention to detail; however, should you find any errors or omissions, please contact Digital Electronics and inform them of your findings.
- 4) Please be aware that Digital Electronics Corporation shall not be held liable by the user for any damages, losses, or third party claims arising from the uses of this product.

All Company/Manufacturer names used in this manual are the registered trademarks of those companies.

© copyright 2002 Digital Electronics Corporation. All rights reserved.

# Essential Safety Precautions

This manual includes procedures that must be followed to operate the DU correctly and safely. Be sure to read this manual and any related materials thoroughly to understand the correct operation and functions of this unit.

## Icon Meaning

Throughout this manual, the following icons are provided next to operations requiring special attention to allow you to use the DU safely. The operations described with these icons contain essential safety information. The following is an example of these icons and their meanings:



Indicates situations where severe bodily injury, death or major equipment damage can occur.



Indicates situations where slight bodily injury or machine damage can occur.

## WARNINGS

### System Design

- **Before connecting the DU's power cord terminals to its terminal block, be sure the power cord is disconnected from the power supply.**
- **Do not use power that is beyond the DU's specified voltage range. It may cause a fire or electric shock.**
- **Before opening the DU unit's cover, to prevent electric shocks or burns, be sure to disconnect the DU's power cord from the power supply.**
- **Do not modify the DU unit. It may cause a fire or an electric shock.**
- **Do not create touch panel switches which could possibly endanger the safety of humans or equipment. This is due to the possibility of a malfunction in the DU, PL or its cable(s) causing the output of a signal that could result in a major accident. All of a system's major, safety-related switches should be designed to be operated separately from the DU.**

- Do not use the DU unit as a warning device for critical alarms that can cause serious operator injury, machine damage or production stoppage. Critical alarm indicators and their control/activator units must be designed using stand-alone hardware and/or mechanical interlocks.
- After the DU's backlight burns out, unlike the DU's "Standby Mode", the touch panel is still active. If the operator fails to notice that the backlight is burned out and touches the panel, a potentially dangerous machine miss-operation can occur.

If your DU's backlight suddenly turns OFF, use the following steps to determine if the backlight is actually burned out.

- 1) If your PL is not set to "Standby Mode" and the screen has gone blank, your backlight is burned out.
  - 2) Or, if your PL is set to Standby Mode, but touching the screen does not cause the display to reappear, your backlight is burned out.
- Do not allow water, liquids, or metal particles to enter inside the DU's chassis, since they can cause either a malfunction or an electrical shock. If, however, either of these events occurs, disconnect the DU unit's power cord immediately and contact your local DU distributor.
  - Read and understand Chapter 4 "Installation and Wiring" thoroughly before selecting an installation location for the DU.
  - Do not insert/remove an expansion board or an interface unit while the DU unit's power cord is connected to the power supply.
  - To prevent a possible explosion, do not install the DU in areas containing flammable gases.
  - The DU is not appropriate for use with aircraft control devices, aerospace equipment, central trunk data transmission (communication) devices, nuclear power control devices, or medical life support equipment, due to these devices' inherent requirements of extremely high levels of safety and reliability.
  - When using the DU with transportation vehicles (trains, cars and ships), disaster and crime prevention devices, various types of safety equipment, non life-support related medical devices, etc. redundant and/or fail-safe system designs should be used to ensure the sufficient degree of reliability and safety.



## CAUTIONS

- When the surface or the frame of the display becomes dirty, soak a soft cloth in water with a neutral detergent, wring the cloth tightly, and wipe the display. Do not use paint thinner, organic solvents, or a strong acid compound to clean the unit.
- Avoid using or storing the DU in direct sunlight, or in excessively dusty, dirty or hot environments.
- Do not use the DU in areas where large, sudden temperature changes can occur thereby causing condensation to form inside the unit. This can cause the unit to malfunction.
- Avoid restricting the DU's naturally occurring ventilation, or storing or using the DU in an environment that is too hot.
- Do not store or use the DU where chemicals and acids evaporate, or where chemicals and acids are dispersed into the air.
- Do not hold the DU's display stand to carry the DU. This stand is not meant for carrying the DU and if it breaks, the unit may fall and injure you.

### LCD Handling Caution

The DU's LCD contains a strong irritant. If the panel is ever cracked and the LCD's liquid contacts your skin, be sure to wash it with running water for at least 15 minutes. If any of this liquid should enter your eye, be sure to flush your eye with running water for more than 15 minutes and see a doctor as soon as possible.

# General Safety Precautions

---

## LCD Usage and Handling

- The brightness of the LCD screen will depend on the screen's current display and the LCD's contrast adjustment. Any brightness variations that result are normal for LCD displays.
- There are minute grid-points (Dark or Light points) on the LCD surface. These points are not defects and are a part of the DU panel's design.
- The displayed color will look different when viewed from an angle outside the specified view angle. This is also normal.
- When installing this unit, be sure that the screen is viewable from within the designated direction, otherwise the view angle will be effected.
- Displaying a single screen image for long periods of time can cause an afterimage to remain on the screen. To correct this, turn the unit OFF for 5 to 10 minutes, then ON again. This phenomenon is a common attribute of the LCDs, and is not a defect. To prevent this effect, you can:
  - 1) Use the Display OFF feature; if the same image is to be displayed for a long period of time.
  - 2) Change the screen display periodically to prevent the displaying of a single image for a long period of time.(For further information about LCD usage and handling, contact your local DU distributor.)

# Prior to Using the DU

---

## ■ Additional Floppy Disk

When attaching a DU Standard Display to a PL unit, the Touch Panel Device Driver (Mouse Emulator) is required (included with the PL-B920 Series unit).

## "USB Touch Panel Control Utility Disk" - 2 disks

These disks contain the USB Touch Panel Device Driver. This software is used when the connection method is "USB".

When attaching this display's touch panel interface to a PL Series unit using a USB connection, be sure to install the USB Touch Panel Device Driver (USB Touch Panel Control Utility Disk) included with this display.

Be aware that in this situation, the PL-B910 Series unit's "USB Touch Panel Control Utility Disk" cannot be used.

For details on installing the USB Touch Panel Device Driver, refer to the floppy disk's "Readmee.wri" file.

## "FP-ME000" - 2 disks

These disks contain the Japanese version of the touch panel driver U-TP. This software is used when the touch panel connection method is "RS-422" and the OS is Japanese.

Prior to installing and using the FP-ME000 software, be sure that you read and accept the usage conditions stated in the "Software License Agreement".

For installation and usage information, refer to the "U-TP Installation Procedures" or the "U-TP User Guide Procedures" files contained in these floppy disks.



- **Opening a PDF file requires that the Adobe® Acrobat® Reader software be installed on your PC. The Acrobat® Reader software is contained in the PL-B920 Series unit's CD-ROM disk. Please use this CD-ROM to install the software.**
- **When using "RS-422" connection with an English OS, the Gunze corporation's "U-TP" software is required. For purchasing information, contact your local Pro-face distributor.**

## ■ Touch Panel Calibration

After connecting the DU to the PL and setting up the PL's OS, you will need to input the DU's screen settings and perform touch panel calibration.

**▼Reference▲** *BOX-Type Industrial Computer PL-B920 Series User Manual*

## ■ Power LEDs during Screen Mode Changeover

When connecting a DU unit to a PL unit, the DU unit's power LED may blink orange when the screen's display mode is changed. This is due to the PL unit's requiring a 1 second stop of display output.



**▼Reference▲** *2.3 Names and Functions of DU Parts*

## ■ When Using the USB Connector

When using a USB hub to connect USB compatible devices to the PL-B920 unit, be sure to use one of the PL unit's side-by-side USB ports (2), not the single USB port. The DU unit, however, cannot use a USB hub when connecting USB devices.

# Documentation Conventions

The list below describes the documentation conventions used in this manual.

Symbol	Meaning
	Indicates important information or procedures that <u>must</u> be followed for correct and risk-free software/device operation.
*1	Indicates useful or important supplemental information.
1) , 2)	Indicates steps in a procedure. Be sure to perform these steps in the order given.
	Refers to useful or important supplemental information.
	Provides useful or important supplemental information.
PL	Refers to all BOX-Type Industrial Computers (PL-B920 Series models).
DU	Refers to all standard Displays (PL-DU6900, PL-DU7900).

## PL Model Number

The meaning of the DU model number is explained below.

PL-DU \* 900 - T42

A      B      C      D      E F G

Item	Code	Meaning
A	PL	PL Series Industrial Computer
B	DU	PL-B920 Series Display Unit
C	6	12.1 inch SVGA
	7	15 inch XGA
D	9	X900 Series
E	T	TFT Color LCD
F	4	CE Marked, UL/c-UL(CSA) Approved
G	2	Revision No.



# Special Features

---

The PL-DU\*900's special features are as follows.

■ **PL-DU6900 - 12.1" High-Brightness Color Display and Wide View Angle**

The PL-DU6900's large 12.1 inch, 800 X 600 pixel TFT LCD display offers excellent visibility and brightness.



**Note:** Pro-face's top of the line TFT color LCD model allows you to create detailed and powerful visual images, with excellent brightness, a wide viewing angle, and a display capable of 260,000 colors.

■ **PL-DU7900 - 15.0" High-Brightness Color Display and Wide View Angle**

The PL-DU7900's large 15.0 inch, 1024 X 768 pixel TFT LCD display offers excellent visibility and brightness.



**Note:** Pro-face's top of the line TFT color LCD model allows you to create detailed and powerful visual images, with excellent brightness, a wide viewing angle, and a display capable of 260,000 colors.

■ **Installation Options**

The PL's separately designed main unit and display offer you an expanded range of usage options for all your applications.

■ **Easy Front Panel Installation**

The PL is designed to be installed easily into the front of any panel or device. It is also rugged enough for use in harsh, industrial environments, such as those found in the factory automation industries and boasts an IP65f rating.

■ **High Resolution, Resistive Film Touch Panel**

Standard equipment with the PL is a high resolution 1024 X 1024 touch panel. Also, the mouse emulation utility provides mouse-like functionality and pointer control.

■ **USB Interface Feature**

The DU is equipped with a USB interface which allows you to connect the DU with any other USB equipped units (USB I/F Series A).

# Package Contents

The DU's packing box contains the items listed below. Please check to confirm that all items shown below have been included.

## ■ DU Unit (1)

PL-DU6900-T42  
PL-DU7900-T42

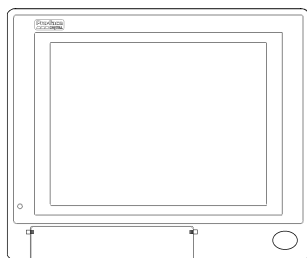

## ■ Installation Fasteners

(PL-DU6900 8/set)  
(PL-DU7900 12/set)

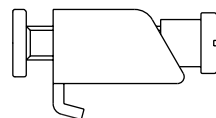

## ■ Power Cord (1)

(for AC100V/AC115V)

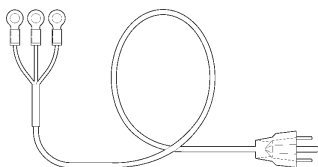

*This power cord is designed only for AC100V/AC115V use. Be sure to use a different cable when using other than AC100V/AC115V power.*

## ■ Floppy Disks

USB Touch Panel Control Utility Disk (2)



FP-ME000 (2)



*FP-ME000 contains the Japanese version of the touch panel driver U-TP.*

**▼ Reference ▲** *1.1.1 When Setting Up the Touch Panel*

## ■ PL-B920 Series Standard Display

PL-DU6900/PL-DU7900 User Manual :  
English/Japanese (1)  
(This manual)

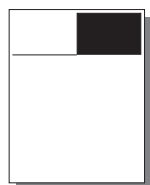

# UL/c-UL(CSA) Application Notes

---

The PL-DU\*900-T4\* units are UL/c-UL(CSA)1950 recognized product. (UL File No. E171486). Machinery which has a DU installed in it requires UL/c-UL inspection for the combination of this unit and the machinery.

**This unit conforms as a component to the following standards:**

UL 1950, Third Edition, dated 1998 March 1st.

(Standard for Safety of Information Technology Equipment, including Electrical Business Equipment)

CAN/C22.2 No.950-M95

(Standard for Safety of Information Technology Equipment, including Electrical Business Equipment)

**PL-DU6900-T4\* (UL Registration Model: 2780053-04)**

**PL-DU7900-T4\* (UL Registration Model: 2780053-03)**

- The DU must be used as a built-in component of an end-use product.
- Use the DU indoors only.
- When connecting the DU's power cord, be sure to use a cord that is appropriate for the current and voltage used (0.75mm<sup>2</sup> or larger).
- When installing the DU in a metal panel or cabinet, be sure to design the DU's power cut-off switch as a separate device that is within easy reach by the unit's operator.
- There is a danger of explosion if the DU's backup battery is incorrectly replaced. Replace only with same or equivalent type recommended by the manufacturer. Dispose of used batteries according to the manufacturer's instructions.
- Be sure the unit the DU is built into uses a UL1950 UL/c-UL(CSA) approved structure.

## CE Marking Notes

---

The PL-DU\*900-T4\* is a CE marked product that conforms to EMC directives.

**This unit conforms as a component to the following standards:**

Safety	EN60950
EMI <EN50081-2>	EN55011, Class A
EMS <EN50082-2>	EN61000-4-2, EN61000-4-3, EN61000-4-4, EN61000-4-6, EN61000-4-8, ENV50204

**The DU unit may fail to meet the above standards if the following conditions are not maintained.**

- The DU must be used as a built-in component of an end-use product.
- Use the DU indoors only.

- When connecting the DU's power cord, be sure to use a cord that is appropriate for the current and voltage used (0.75mm<sup>2</sup> or larger).
- When installing the DU in a metal panel or cabinet, be sure to design the DU's power cut-off switch as a separate device that is within easy reach by the unit's operator.
- There is a danger of explosion if the DU's backup battery is incorrectly replaced. Replace only with same or equivalent type recommended by the manufacturer. Dispose of used batteries according to the manufacturer's instructions.
- Be sure the unit the DU is built into uses an EN60950 approved structure.

# Table of Contents

<b>Preface .....</b>	<b>E1</b>
<b>Essential Safety Precautions .....</b>	<b>E2</b>
<b>General Safety Precautions .....</b>	<b>E5</b>
<b>Prior to Using the DU .....</b>	<b>E6</b>
<b>Documentation Conventions .....</b>	<b>E7</b>
<b>PL Model Number .....</b>	<b>E7</b>
<b>Special Features .....</b>	<b>E8</b>
<b>Package Contents .....</b>	<b>E9</b>
<b>UL/c-UL(CSA) Application Notes .....</b>	<b>E10</b>
<b>CE Marking Notes .....</b>	<b>E10</b>
<b>Table of Contents .....</b>	<b>E12</b>

## CHAPTER 1 INTRODUCTION

<b>1.1 System Design .....</b>	<b>E1-1</b>
1.1.1 When Setting Up the Touch Panel .....	E1-2
<b>1.2 Accessories .....</b>	<b>E1-3</b>

## CHAPTER 2 SPECIFICATIONS

<b>2.1 General Specifications .....</b>	<b>E2-1</b>
2.1.1 Electrical .....	E2-1
2.1.2 Environmental .....	E2-1
2.1.3 Structural .....	E2-2
<b>2.2 Functional Specifications .....</b>	<b>E2-3</b>
2.2.1 Performance .....	E2-3
2.2.2 Display .....	E2-3
<b>2.3 Names and Functions of DU Parts .....</b>	<b>E2-4</b>
<b>2.4 Display Unit Dimensions .....</b>	<b>E2-5</b>
2.4.1 PL-DU6900 External Dimensions .....	E2-5
2.4.2 PL-DU7900 External Dimensions .....	E2-5
2.4.3 PL-DU6900 Panel Cut .....	E2-6
2.4.4 PL-DU7900 Panel Cut .....	E2-6

**CHAPTER 3 OPTIONAL UNITS**

**3.1 Installation ..... E3-1**  
 3.1.1 Installing the USB Front Access Unit (PL-US200) ..... E3-2

**CHAPTER 4 INSTALLATION AND WIRING**

**4.1 DU Installation Cautions ..... E4-1**  
 4.1.1 Temperature Related Cautions ..... E4-1  
 4.1.2 Installation Positioning Cautions ..... E4-1  
 4.1.3 Shock / Vibration Related Cautions ..... E4-1  
**4.2 DU Installation ..... E4-2**  
 4.2.1 Installation ..... E4-2  
**4.3 Wiring Cautions ..... E4-5**  
 4.3.1 Connecting to PL ..... E4-5  
 4.3.2 Connecting the Power Cord ..... E4-5  
 4.3.3 Connecting the DU's Power Supply ..... E4-7  
 4.3.4 Grounding the DU ..... E4-8  
 4.3.5 Cautions When Connecting I/O Signal Lines ..... E4-8

**CHAPTER 5 MAINTENANCE**

**5.1 Regular Cleaning ..... E5-1**  
 5.1.1 Cleaning the Display ..... E5-1  
 5.1.2 Installation Gasket Replacement ..... E5-2  
**5.2 Changing the Backlight ..... E5-3**  
**5.3 Periodic Check Points ..... E5-10**

**INDEX**

# *Memo*

# Chapter 1 Introduction

1. System Design
2. Accessories

## 1.1 System Design

---

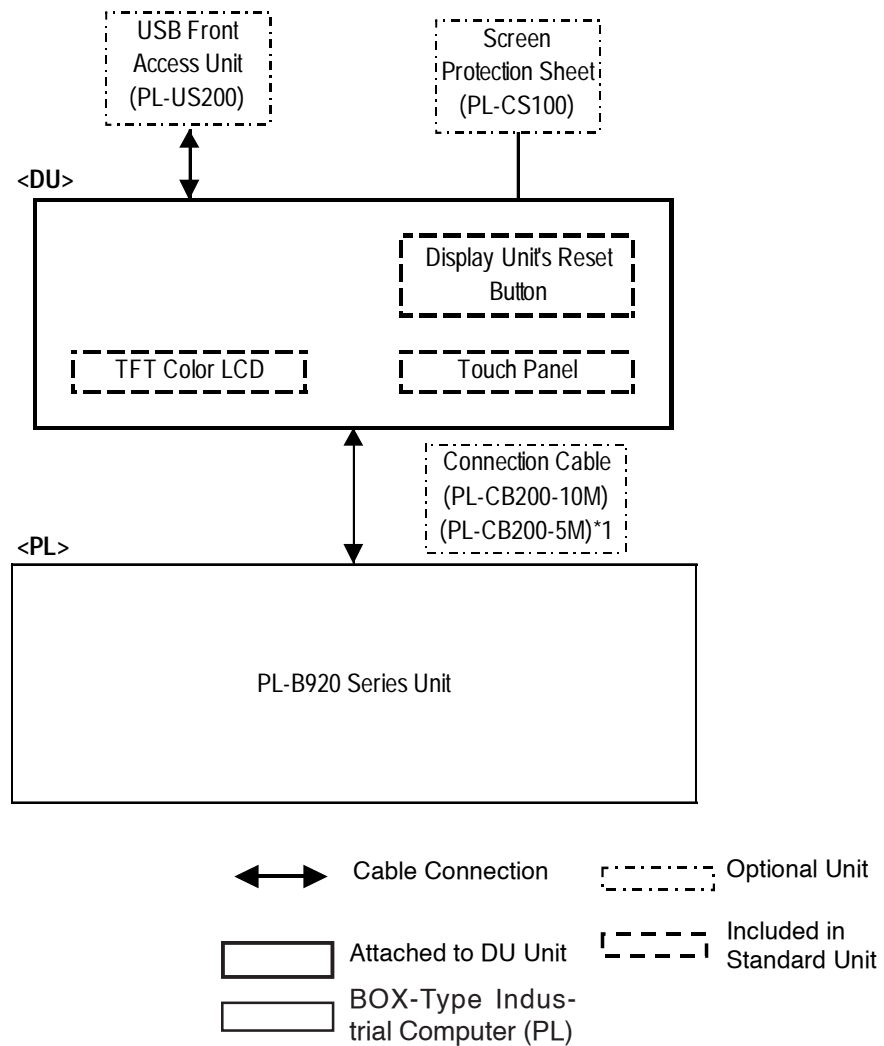

\*1 When connecting the Touch Panel using a USB cable, be sure to use the PL-CB200-5M.



**The above System Configuration indicates only the connection between DU unit and the PL. The actual positioning of these units will differ.**



# Chapter 1 - Introduction

## 1.1.1 When Setting Up the Touch Panel

You can connect a touch panel using either RS-422 or USB. As shown below, each connection method has its limitations concerning the OS and Touch Panel Device Driver that can be used.

Touch Panel Connection Method	OS Type	Touch Panel Device Driver (Mouse Emulator)
RS-422	Windows® 95	When using Japanese OS: FP-ME000 (included with DU unit) When using English OS: U-TP English version *1 (Gunze Inc.)
	Windows® 98 Second Edition	
	Windows NT® 4.0	
	Windows® 2000	
USB	Windows® 98 Second Edition	USB Touch Panel Device Driver (included with DU unit)
	Windows® 2000	

\*1 When using "RS-422" connection with an English OS, the English-version of Gunze corporation's "U-TP" software is required. For purchasing information, contact your local Pro-face distributor.



- **When a DU is connected via a USB cable, be sure to wait 3 seconds after turning the power OFF before turning it ON again.**
- **Be sure to use only the OS types shown here with each cable. If a different type OS is used, the utility software (drivers, etc.) is not supported.**

### ■ System Parameter Setup

Depending on the type of touch panel connection method used, the PL unit's system (BIOS) settings will differ. The PL unit's factory-set connection method is for an RS-422 cable.

**Reference** "BOX-Type Industrial Computer PL-B920 Series User Manual"

### ■ Dip Switch Settings

Depending on the touch panel cable used, the DU unit's rear face dip switch settings will change. These settings must also be set on the PL unit's side face dip switches.

#### ◆ RS-422 Connection Settings

PL Settings	SW No.	1	2	3	4
	On or OFF	ON	OFF	ON	OFF

DU Settings	SW No.	1	2	3	4	5	6	7	8
	On or OFF	ON	OFF	ON	OFF	Reserved			ON

#### ◆ USB Connection Settings

PL Settings	SW No.	1	2	3	4
	On or OFF	OFF	ON	OFF	ON

DU Settings	SW No.	1	2	3	4	5	6	7	8
	On or OFF	OFF	ON	OFF	ON	Reserved			OFF

## 1.2 Accessories

All accessories listed below are produced by the Digital Electronics Corporation.

### ■ Attachment Units

Product Name	Model No.	Description
USB Front Access Unit	PL-US200	Allows you to connect other USB equipped units to the DU from the front of the DU.

### ■ Screen Protection Items

Product Name	Model No.	Description
Screen Protection Sheet	PL-CS100	Disposable protective and dirt-resistant sheet for the DU's screen. The DU's touch panel can be used with this cover sheet attached. (5/set) <Both for PL-DU6900 and PL-DU7900>

### ■ Display Cables

Product Name	Model No.	Description
Display Expansion Board	PL-CB200-5M	Connects Standard Display and Main Unit. (5m)
USB Front Access Unit	PL-CB200-10M	Connects Standard Display and Main Unit. (10m) (Used only with RS-422 connection)

### ■ Maintenance Items

These optional items were originally included in either the DU itself or in its packing box. These items are sold separately as optional maintenance items.

Product Name	Model No.	Description
Installation Fastener	GP070-AT01	Fasteners to attach the DU to a panel. Same as the fastener included in the DU's original equipment package.
Installation Gasket	PL6900-WP00	Provides a drip resistant seal when installing the DU. <For PL-DU6900>
	PL7900-WP00	Provides a drip resistant seal when installing the DU. <For PL-DU7900>
Replacement Backlight	GP675-BL00-MS	Spare Backlight for maintenance. (2 bulbs/set) <For PL-DU6900>
	PL7900-BL00-MS	Spare Backlight for maintenance. (2 bulbs/set) <For PL-DU7900>

## Chapter 1 - Introduction

### ■ Commercially Available Items

The PL-B910 Series units can use USB compatible devices. However, among the commercially available USB devices, not all will be compatible with the PL unit. For a list of the USB units that can be used with your PL, please contact your local PL distributor.



**Note:**

When using USB type devices, be sure they are USB compatible, and be sure to read that device's installation guide prior to connecting it to the PL.

# Chapter

# 2 Specifications

1. General Specifications
2. Functional Specifications
3. Names and Functions of DU Parts
4. Display Unit Dimensions

## 2.1 General Specifications

---

### 2.1.1 Electrical

---

<b>Rated Voltage</b>	AC100V to AC240V
<b>Rated Voltage Range</b>	AC85V to AC265V
<b>Rated Frequency</b>	50Hz or 60Hz
<b>Allowable Voltage Interruption</b>	1 cycle or less (Actual interruption can be more than 1 second)
<b>Power Consumption</b>	50VA or less
<b>Voltage Endurance</b>	AC1500V, 20mA for 1 minute (between charging and FG terminals)
<b>Insulation Resistance</b>	10M $\Omega$ or higher at DC500V (between charging and FG terminals)

### 2.1.2 Environmental

---

<b>Ambient Operating Temperature (Panel interior and Panel face)</b>	0°C to +50°C
<b>Storage Temperature</b>	-10°C to +60°C
<b>Ambient Humidity</b>	10%RH to 85%RH (with no condensation)
<b>Maximum Wet Bulb Temperature</b>	29°C
<b>Atmosphere</b>	Free of conductive dust and corrosive gasses
<b>Vibration Endurance</b>	19.6m/s <sup>2</sup> (10Hz to 25Hz in X, Y, Z directions for 30min.)
<b>Noise Endurance (Impulse Noise)</b>	Noise Voltage: 1500V Pulse Duration: 50ns, 500ns, 1 $\mu$ s Arise Time: 1ns (via noise simulator)
<b>Electrostatic Discharge Immunity</b>	4kV (complies with IEC 61000-4-2)
<b>Noise Immunity(First transient burst noise)</b>	2kV (complies with IEC 61000-4-4)

## Chapter 2 - Specifications

### 2.1.3 Structural

	PL-DU6900	PL-DU7900
<b>Grounding</b>	100Ω or less ,or your country's applicable standard <sup>*1</sup>	
<b>Protection</b>	Equivalent to IP65f <sup>*2</sup> (JEM1030) (front face only - when installed in panel) Unit Composition: Single Unit Type Installation Method: In a solid panel	
<b>Cooling Method</b>	Natural air circulation	
<b>Weight</b>	5.5 Kg (12.1lb) or less	7.0 Kg (15.4lb) or less
<b>External Dimensions</b>	346mm (13.62in.) <W> x 287mm (11.3in.) <H> x 63mm (2.48in.) <D> (main unit only)	374mm (14.72in.) <W> x 325mm (12.8in.) <H> x 74mm (2.91in.) <D> (main unit only)

\*1  Refer to 4.3.4 Grounding the DU

\*2 The front face of the DU unit, installed in a solid panel, has been tested using conditions equivalent to the standards shown in the specification . Even though the DU unit's level of resistance is equivalent to these standards, oils that should have no effect on the DU can possibly harm the unit. This can occur in areas where either vaporized oils are present, or where low viscosity cutting oils are allowed to adhere to the unit for long periods of time. If the DU's front face protection sheet becomes peeled off, these conditions can lead to the ingress of oil into the DU and separate protection measures are suggested. Also, if non-approved oils are present, it may cause deformation or corrosion of the front panel's plastic cover. Therefore, prior to installing the DU be sure to confirm the type of conditions that will be present in the DU's operating environment.

If the installation gasket is used for a long period of time, or if the unit and its gasket are removed from the panel, the original level of the protection cannot be guaranteed. To maintain the original protection level, you need to replace the installation gasket regularly.



**When using the DU with an optional unit, be sure to also confirm the option unit's specifications.**

## 2.2 Functional Specifications

### 2.2.1 Performance

		PL-DU6900	PL-DU7900
<b>Graphics</b>		SVGA (800 X 600 dots)	XGA (1024 X 768 dots)
<b>VESA</b>		16 colors/ 256 colors/ 32k colors/ 64k colors	
<b>Display Unit</b>		12.1 inch TFT SVGA	15.0 inch TFT XGA
<b>Touch Panel I/F</b>	<b>Type</b>	Resistive Film (Analog)	
	<b>Resolution</b>	1024 X 1024	
	<b>Interface</b>	COM4 (Uses Mouse Emulator) USB Interface (USB cable uses the USB interface)	
<b>USB I/F</b>		1ch (Only when using USB cable)	

### 2.2.2 Display

		PL-DU6900	PL-DU7900
<b>Type</b>		TFT Color LCD (12.1 inch)	TFT Color LCD (15 inch)
<b>Density</b>		800 X 600 pixels	1024 X 768 pixels
<b>Dot Pitch</b>		0.3075mm X 0.3075 mm (0.01in. X 0.01in.)	0.297mm X 0.297mm (0.01in. X 0.01in.)
<b>Nominal Display Area</b>		246.0mm X 184.5 mm (9.69in. X 7.26in.)	304.1mm X 228.1mm (11.97in. X 8.98in.)
<b>Colors</b>		260,000	
<b>Brightness Control</b>		Not Available	Available
<b>Contrast Control</b>		Not Available	
<b>Backlight</b>		CCFL (Replaceable)	
<b>Backlight Lifetime</b> (time required for brightness to fall to half its normal level)		25,000 hours at an ambient temperature of 25°C	50,000 hours at an ambient temperature of 25°C



**When replacing the Backlight, contact your local distributor.**

**Reference** [5.2 Changing the Backlight](#)

## 2.3 Names and Functions of DU Parts

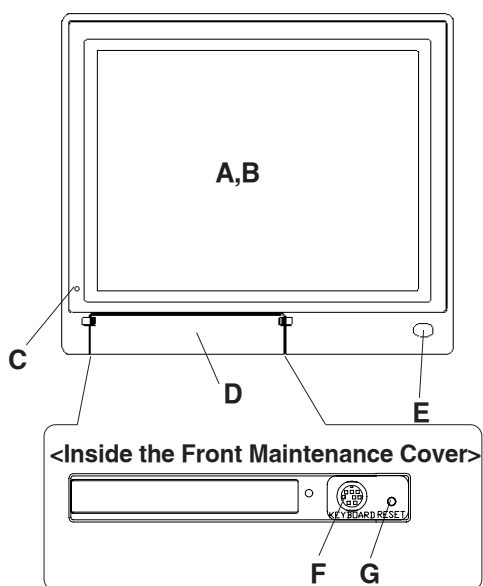

PL-DU6900

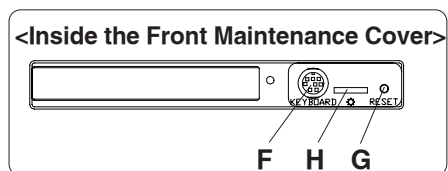

PL-DU7900

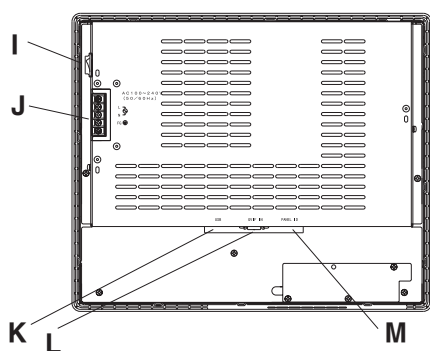

PL-DU6900 Rear View

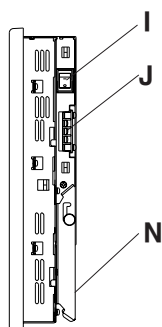

PL-DU6900 Side View

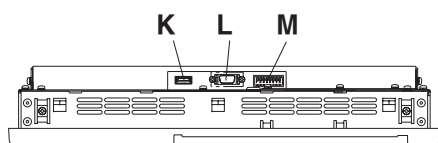

PL-DU6900 Bottom View

### A: Display Area

Display output area.

### B: Touch Panel

A high resolution analog type touch panel. Allows you to create your control systems without using a key board.

### C: Status LED

The status of the lamp changes according to the alarm type detected by the RAS feature.

**Reference** *BOX-Type Industrial Computer PL-B920 Series User Manual*

### D: Front Maintenance Cover

Open this cover when using the Hardware Reset Switch.

### E: IrDA

This feature is currently unavailable.

### F: Keyboard Connector (KEYBOARD)

This feature is currently unavailable.

### G: Hardware Reset Switch (RESET)

Resets the Display Unit only.

### H: Brightness Adjustment Slide

Allows adjustment of backlight brightness. (Can be used for PL-DU7900 only.)

### I: Power Switch

Turns ON/OFF the DU's power supply.

### J: Power Terminals

The DU's AC100V/240V power cord terminals are connected here.

### K: USB Connector (USB)

USB I/F, (USB 1.0 compatible.) Any other USB connection compatible units can be connected here.

### L: PL Connector (GVIF IN)

The communication interface for PL-B920. To use this connector, the optional cable (PL-CB200-5M or PL-CB200-10M) is required.

### M: Dip Switch (PANEL ID)

Used for setting the Touch Panel Communication method (RS-422/USB) and station (ID) numbers.

**Reference** *1.1.1 When Setting Up the Touch Panel ■ Dip Switch Settings*

### N: Display Stand

Used to support the DU when it is removed from its installation panel.

## 2.4 Display Unit Dimensions

### 2.4.1 PL-DU6900 External Dimensions

Unit: mm <in.> (Main Unit Only)

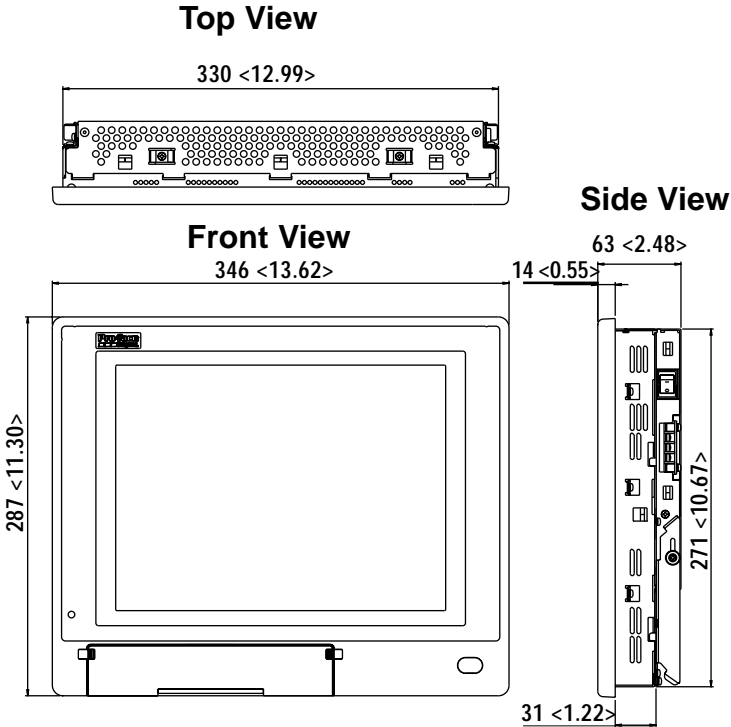

### 2.4.2 PL-DU7900 External Dimensions

Unit: mm <in.> (Main Unit Only)

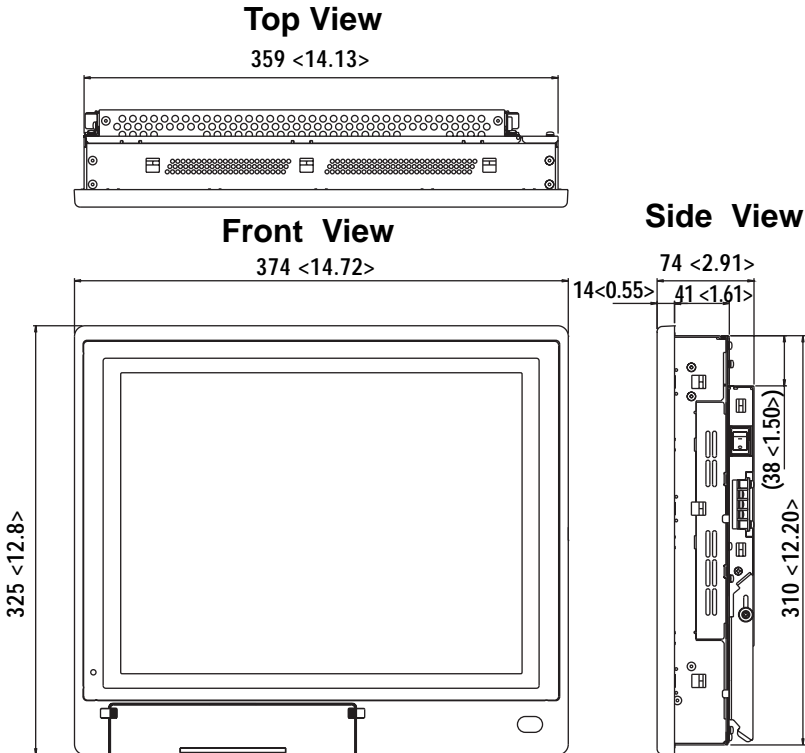



## Chapter 2 - Specifications

### 2.4.3 PL-DU6900 Panel Cut

---

Unit: mm <in.>

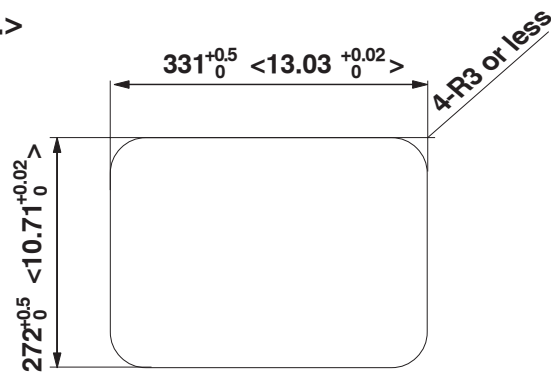

- **Be sure the thickness of the panel is from 1.6mm (0.06in.) to 10mm (0.39 in.)**
- **Depending on material used for panel surface, you may need to strengthen the panel surface. Especially, if high levels of vibration are expected and the DU's installation surface (i.e. an operation panel's door, etc.) can move (i.e. open or close) due consideration should be given to the DU's weight.**
- **To insure that the DU's water resistance is maintained, be sure to install the DU into a panel that is flat and free of scratches or dents.**
- **Be sure all installation tolerances are maintained to prevent the unit from falling out of its installation panel, or allowing water to enter inside.**

### 2.4.4 PL-DU7900 Panel Cut

---

Unit: mm <in.>

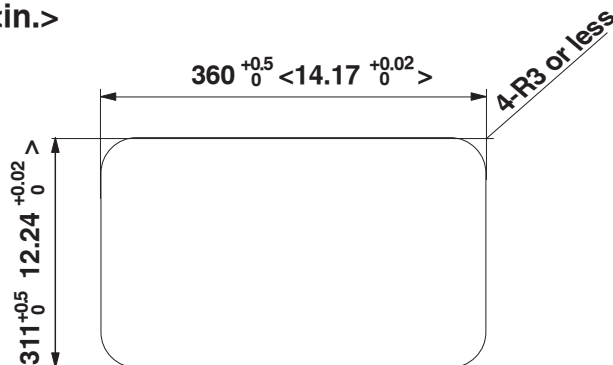

- **Be sure the thickness of the panel is from 1.6mm (0.06in.) to 10mm (0.39 in.)**
- **Depending on material used for panel surface, you may need to strengthen the panel surface. Especially, if high levels of vibration are expected and the DU's installation surface (i.e. an operation panel's door, etc.) can move (i.e. open or close) due consideration should be given to the DU's weight.**
- **To insure that the DU's water resistance is maintained, be sure to install the DU into a panel that is flat and free of scratches or dents.**
- **Be sure all installation tolerances are maintained to prevent the unit from falling out of its installation panel, or allowing water to enter inside.**

# Chapter

## 3 Optional Units

### 3.1 Installation

---

The following explanation pages describe the installation procedures for the USB Front Access Unit (PL-US200).

For information about the installation of other option units, please refer to those unit's individual [Operation Instructions].



## WARNINGS

**To avoid electric hazards, be sure to turn the DU's power OFF before installing any optional units or expansion boards.**



- ***Use a screwdriver to loosen or tighten the screws. Be careful not to over-tighten any screws, since it may damage the equipment.***
- ***Be careful when removing or inserting any screws that they do not fall inside the body of the DU.***

## Chapter 3 - Optional Units

### 3.1.1 Installing the USB Front Access Unit (PL-US200)

Use the following procedure to install the PL-US200 in the DU.



- **Do not pinch the PL-US200 cable against the DU's chassis or against other devices.**
- **Do not pull the PL-US200's cable too strongly.**

- 1) Unscrew the blank panel's three (3) attachment screws and remove the DU rear face's PL-US200 blank panel.

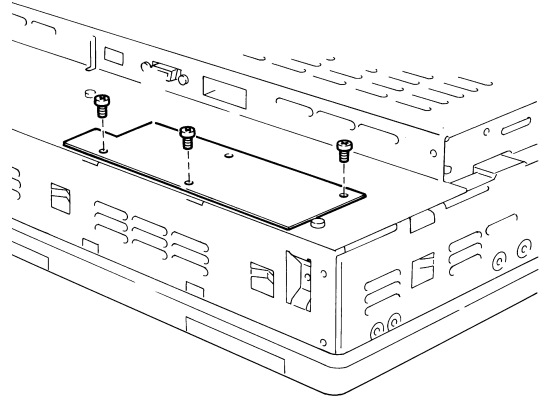

- 2) Unscrew the PL-US200 front blank panel's two (2) screws from inside the DU's rear face.

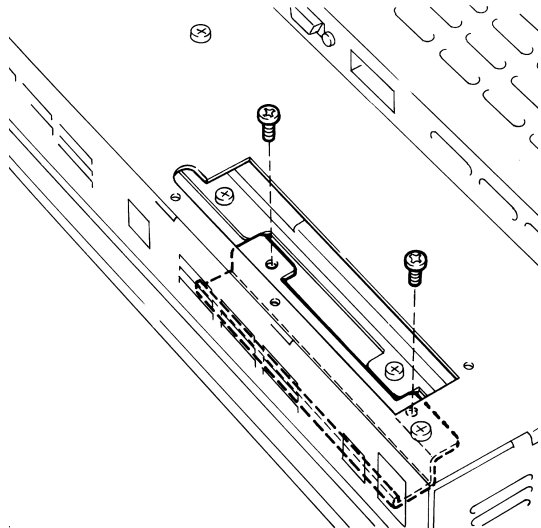

## Chapter 3 - Optional Units

- 3) Insert the PL-US200 into the PL and secure it in place with two (2) attachment screws.

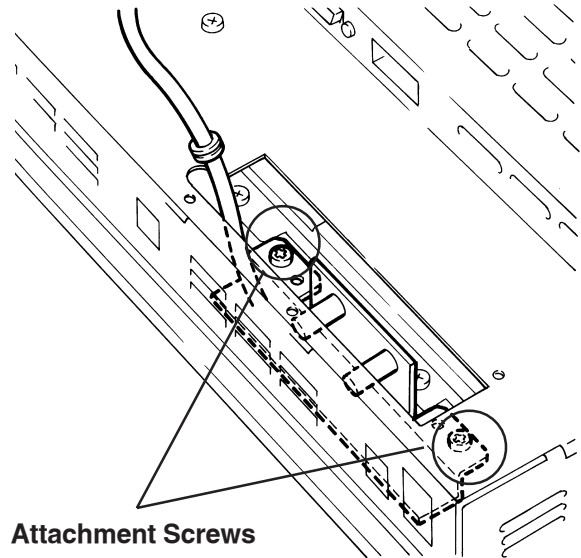

- 4) Insert the PL-US200's USB Connector into the DU's USB Socket.
- 5) Insert the PL-US200 cable's black Rubber Stopper in the DU rear panel's notch. Then, replace the PL-US200's rear blank panel, rotating it 180° from its original orientation, and secure it in place with its three (3) attachment screws.

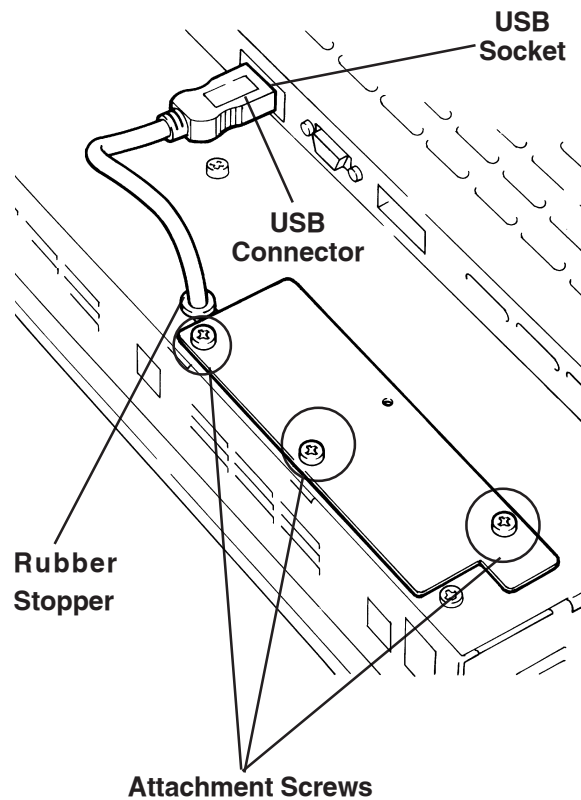

# *Memo*

# Chapter

# 4 Installation and Wiring

1. DU Installation Cautions
2. DU Installation
3. Wiring Cautions

## 4.1 DU Installation Cautions

### 4.1.1 Temperature Related Cautions

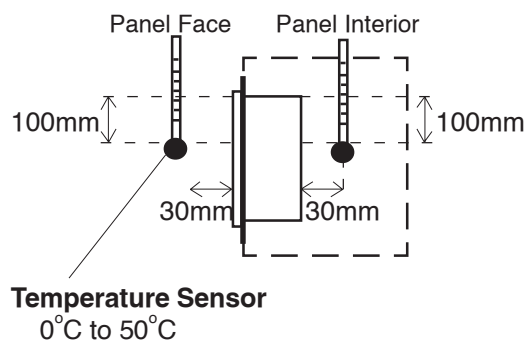

To prevent a machine breakdown, be sure to use the DU within the allowable temperature range as below-listed. Be sure to confirm that the area near the DU will be within the allowable temperature range by placing a temperature sensor in the location shown in the left-side drawing. (“Ambient Operating Temperature” indicates both the panel interior and panel face temperature.)

### 4.1.2 Installation Positioning Cautions

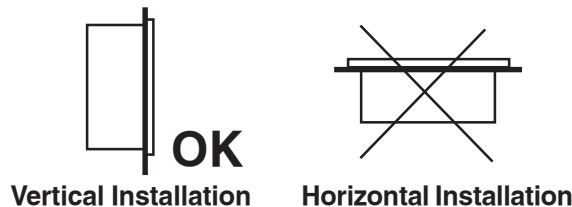

Be sure to install the panel in an upright (vertical) position.

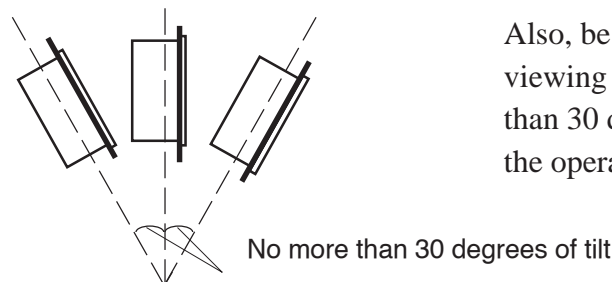

Also, be sure that the panel’s viewing angle is tilted no more than 30 degrees from parallel to the operator (i.e. directly in front).

### 4.1.3 Shock / Vibration Related Cautions

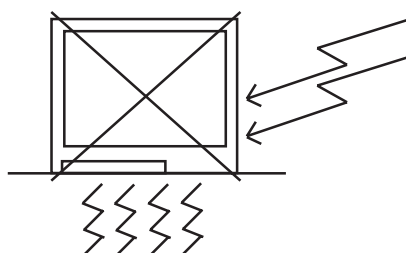

Be sure to protect the DU from excessive vibration or jolting. These kinds of shocks can cause the DU to malfunction.

**Shock Resistance**

19.6m/s<sup>2</sup>

## 4.2 DU Installation

### 4.2.1 Installation

#### ■ Confirm the Installation Gasket's Seating

It is strongly recommended that you use the gasket.

Place the DU on a level surface with the display panel facing downward. Check that the DU's installation gasket is seated securely into the gasket's groove, which runs around the perimeter of the panel's frame.



**Be sure the gasket is in place before installing the DU.**

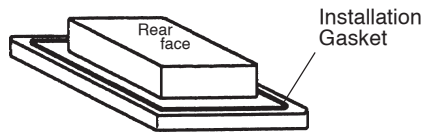

#### ■ Creating a Panel Cut Out

Create the correct sized opening required to install the DU, using the installation dimensions given. The moisture resistant gasket, installation fasteners and attachment screws are all required when installing the DU.

**Reference** 2.4 Display Unit Dimensions

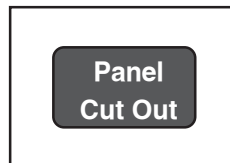

- Check that the installation panel or cabinet's surface is flat, in good condition and has no jagged edges.
- Panel thickness should be from 1.6mm to 10.0mm.
- Be sure to consider the weight of the DU when designing the panel.

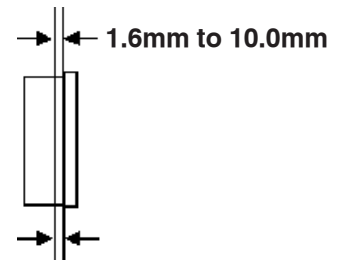

To enhance the DU's maintainability, operability and ventilation, allow at least 50mm clearance between the DU and any other objects. (The clearance must be large enough to allow you to insert or remove expansion boards and to attach connectors.)

Side View

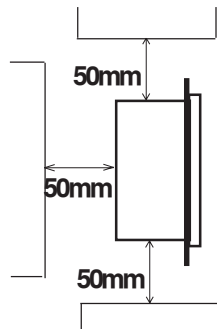

Rear View

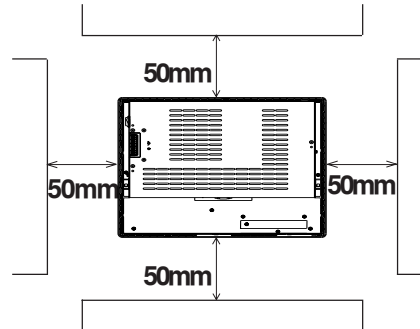

### ■ DU Viewing Angle



- The DU must be installed vertically. Also, the DU uses a cooling fan. To operate the DU correctly, be sure that the panel's viewing angle is tilted no more than 30 degrees from parallel to the operator (i.e. when the operator is directly in front).

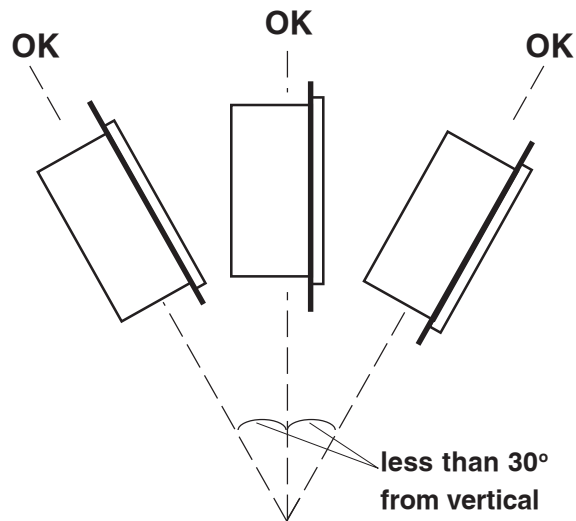

- Avoid placing the DU next to other devices that might cause overheating.
- Avoid using the DU where the ambient temperature will exceed 50°C.
- Keep the DU away from arc-generating devices such as magnetic switches and non-fuse breakers.
- Avoid using the DU in environments where corrosive gases are present.

### ■ Insert the DU into the Panel Cut Out

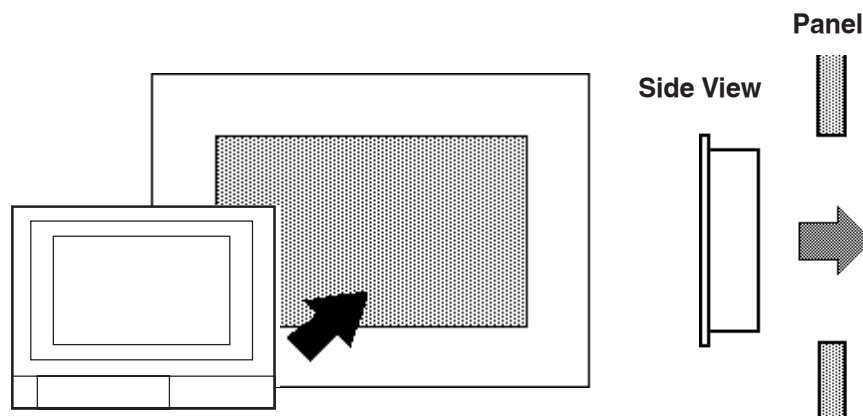

**Be sure the installation panel's actual measurements are the same as those given in this chapter, otherwise the DU may slip or fall out of the panel.**



## Chapter 4 - Installation and Wiring

### ■ Attach and Secure the Rear Installation Fasteners

- 1) Locate the DU's attachment holes, located on the top, bottom, and sides of the DU.

#### PL-DU6900 Series (8 attachment holes)

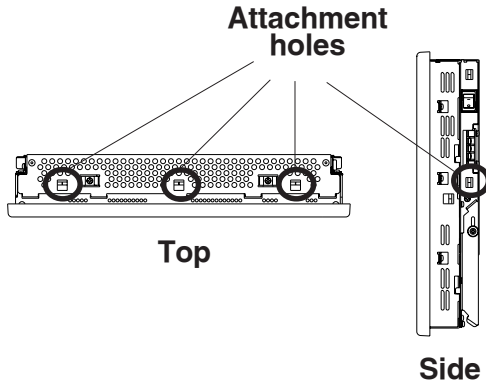

#### PL-DU7900 Series (12 attachment holes)

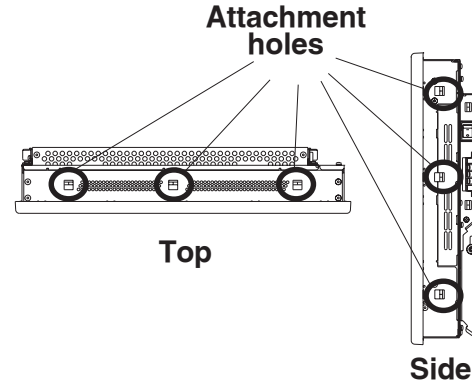

- 2) Insert each fastener into its attachment hole.

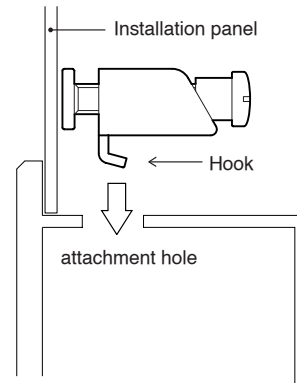

- 3) Slide the fastener backwards until it stops.

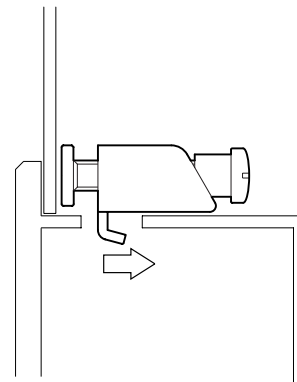

- 4) Use a screwdriver to tighten the fastener's adjustment screw.



**To ensure a high degree of moisture resistance, the torque should be 0.5N•m.**

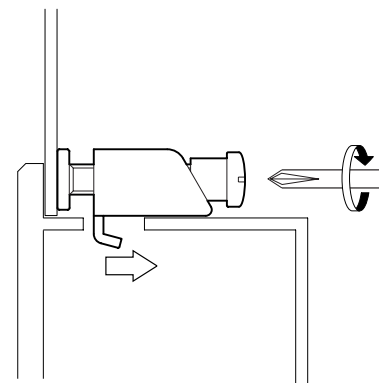

## 4.3 Wiring Cautions

### 4.3.1 Connecting to PL

After connecting the DU to the PL-B920 Series unit and setting up the PL's OS, you will need to complete the DU's screen settings and touch panel calibration.

For details, refer to **Reference** *BOX-Type Industrial Computer PL-B920 Series User Manual*.

### 4.3.2 Connecting the Power Cord

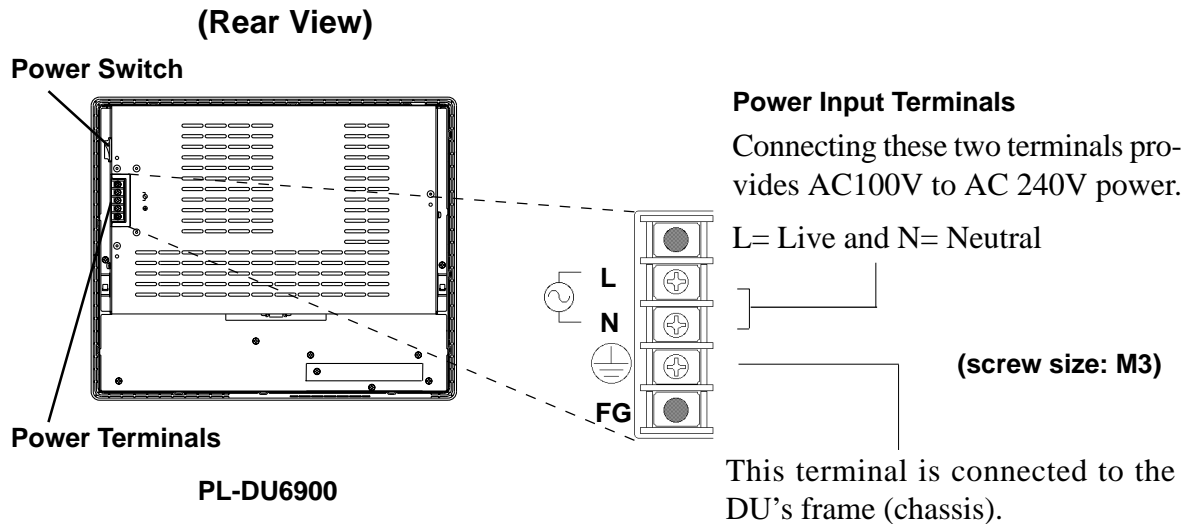

#### ■ Insert the DU into the Panel Cut

- To prevent electric shocks, be sure to turn the DU OFF before connecting the power cord.
- To prevent fires, electrical hazards and equipment damage, be sure to use only the specified power supply voltage when operating the DU.

Use the following steps when connecting the power cord to the DU's power terminals.

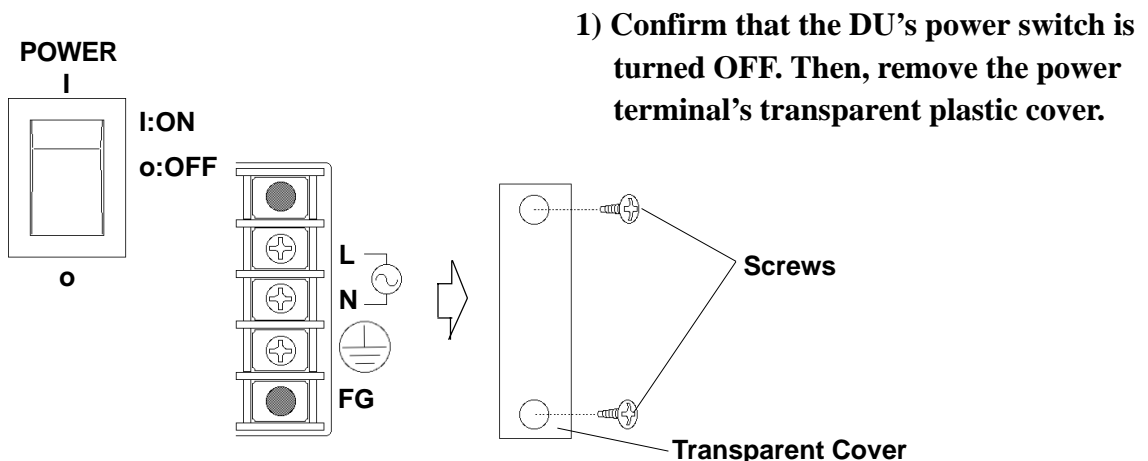

## Chapter 4 - Installation and Wiring

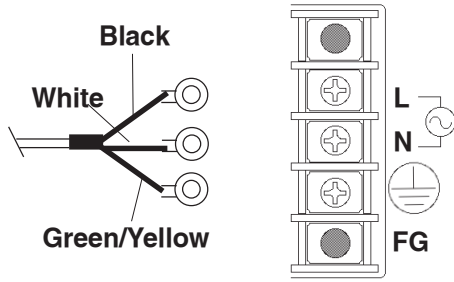

- 2) Loosen and remove the middle three screws from the terminal strip. Align the crimp terminals with each screw hole, and tighten the screws.



- Crimp Terminal Types : V1.25-3, by J.S.T. or equivalent (JIS standard part number : RAV1.25-3)
- Crimp terminals must be the same as shown below.

Max. 6.0 mm   $\phi$  3.2 mm or larger

Attachment Screws

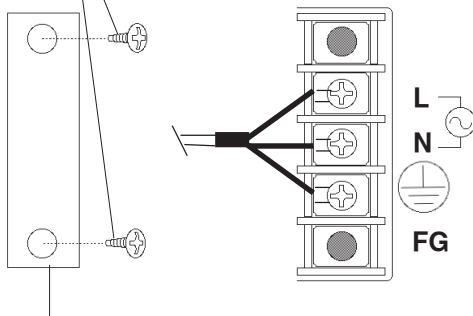

Transparent Cover



**Important**

- The colors used in the figure above are for the cord which came with the DU.
- This power cord is designed only for AC100V/AC115V use. Be sure to use a different cable when using other than AC100V/AC115V power.

- 3) Reattach the terminal strip's transparent cover and secure it in place with its attachment screws.

## 4.3.3 Connecting the DU's Power Supply

Be sure to follow cautions explained here when connecting the power cord to the DU's Power Input Terminals.

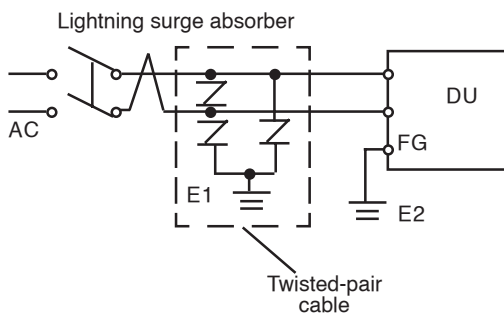
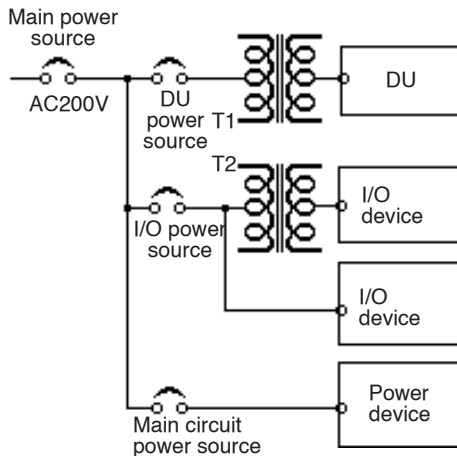
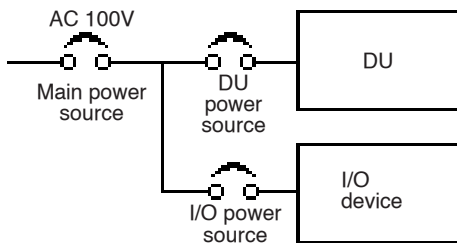
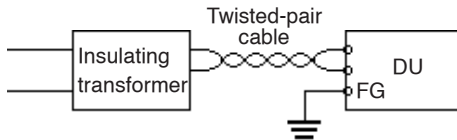
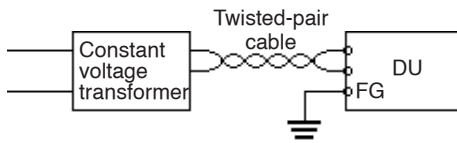

- If voltage fluctuations are expected to vary beyond the specified range, connect a constant voltage transformer.

**Reference** For information about the specified voltage, refer to **2.1 General Specifications.**

- Use a low-noise power supply both between the lines and between the DU and its ground. If there is still excess noise, connect an insulating transformer (noise-prevention type).



**Be sure any constant or insulating transformer used has a capacity of important 70VA or more.**

- Wire the power cords of the DU, I/O devices, and power supply devices separately.

- To improve noise immunity, it is recommended to attach a ferrite core to the power cord.
- Isolate the main circuit (high voltage, large current) line, I/O signal lines, and power cord, and do not bind or group them together.
- To prevent damage from lightning, connect a lightning surge absorber.



**Ground the lightning surge absorber (E1) and the DU (E2) separately.**

- **Select a lightning surge absorber which will not exceed the allowable circuit voltage, even when the voltage rises to the maximum.**

## Chapter 4 - Installation and Wiring

### 4.3.4 Grounding the DU

---

#### (a) Dedicated Ground - best <sup>\*1</sup>



- Set up a dedicated ground when using the rear panel's FG terminal.

#### (b) Shared Ground - allowed <sup>\*1</sup>

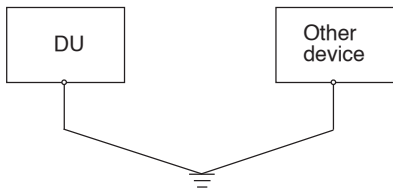

- If a dedicated ground is not possible, use a shared ground, as shown in figure (b).
- The grounding point must be as close to the DU as possible, and the grounding wires must be as short as possible. If the wires must be long, use thick, insulated wires and run them through conduits.

#### (c) Shared ground - not allowed

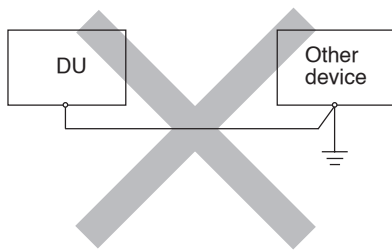

### 4.3.5 Cautions When Connecting I/O Signal Lines

---

- I/O signal lines must be wired separately from the power cord.
- If the power cord needs to be wired together with the cord (I/O) signal lines for any reason, use shielded cables and ground one end of the shield to the DU's FG terminal.
- To improve noise immunity, attaching a ferrite core to the power cord is recommended.

---

*\*1 Use a grounding resistance of 100  $\Omega$  or less, a 2mm<sup>2</sup> or thicker wire, or your country's applicable standard. For details, contact your local DU distributor.*

# Chapter

# 5 Maintenance

1. Regular Cleaning
2. Changing the Backlight
3. Periodic Check Points

## 5.1 Regular Cleaning

---

### 5.1.1 Cleaning the Display

---

When the surface or the frame of the display gets dirty, soak a soft cloth in water with a neutral detergent, wring the cloth tightly, and wipe the display.



- ***Do not use paint thinner, organic solvents, or a strong acid compound to clean the unit.***
- ***Do not use hard or pointed objects to operate the touch-screen panel, since it can damage the panel surface.***



**Note:** Use the optional Screen Protection Sheet when using the DU in extremely dirty or dusty areas.

## Chapter 5 - Maintenance

### 5.1.2 Installation Gasket Replacement

The Installation Gasket protects the DU and improves its water resistance. Even if the your DU's Installation Gasket is not needed to prevent water from entering the unit, the gasket also acts as a vibration absorber and should always be attached.

A gasket which has been used for a long period of time may have scratches or dirt on it, and could have lost much of its water resistance. Be sure to change the gasket periodically (or when scratches or dirt become visible).

#### ■ Attaching the Installation Gasket

To install the gasket, place the PL face down on a soft surface and attach the gasket to the rear side of the display face, in the plastic bezel's groove (see picture below).



- **Since the gasket is flexible but not elastic, be careful not to stretch it unnecessarily, as doing so could tear the gasket.**
- **Be sure, when pushing the gasket into the installation groove and around the corners of the DU, that the gasket's seam is not placed in a corner. Placing the seam there could eventually cause the gasket to tear.**

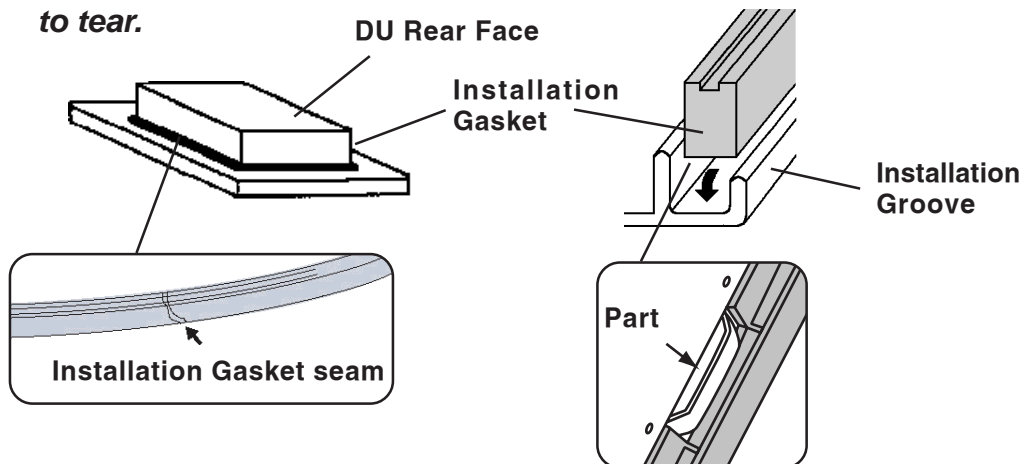

- **Be sure to place the gasket's flat, non-grooved side facing down.**
- **The DU's bezel has a part attached to it. To prevent the installation gasket from contacting this part, be sure to press the installation gasket completely into its groove.**



- **When the installation gasket is properly inserted, approximately 2.0 mm of it will extend outside the groove. Before installing a DU into a panel, be sure to confirm that the gasket is correctly in place.**
- **If the installation gasket is not properly inserted into the groove, the gasket's moisture resistance may not be equivalent to IP65f.**

## 5.2 Changing the Backlight

The DU's backlight can be replaced after it has burned out. To replace the backlight, follow the steps shown below.



**Note:** Please use the following table to identify which backlight model number to use when ordering your backlight.

DU unit	Backlight Type
PL-DU6900	GP675T-BL00-MS
PL-DU7900	PL7900T-BL00-MS



**Important** *If the backlight or the display unit are damaged, the screen display will go out. Even if the screen goes out, however, there is a possibility that the touch panel is still operating correctly. Therefore, since any type of touch panel contact could have an unexpected or dangerous result, be sure not to touch the screen when this condition occurs.*

### WARNINGS

- Whenever changing the backlight, be sure the DU's power cord has been disconnected.
- When the DU's power has just been turned OFF, the backlight area is still very hot! Be sure to wear gloves to prevent being burned.
- When the DU's power cord is connected and the DU is ON, high voltage runs through the wires in the backlight area—*do not touch them!*
- Do not try to replace the backlight while the DU is installed in a cabinet or panel. Remove the DU first, then begin the backlight replacement procedures.
- Do not touch the glass tube. If the glass tube is broken you may be injured.

Follow the steps shown below to replace the DU's backlight. Be sure to wear cotton gloves while replacing the backlight to prevent burns.

- 1) Unplug the DU's power cord from the main power supply. If you do not, it may cause an electric shock.
- 2) Disconnect the DU power cord terminals from the DU's power terminal block.

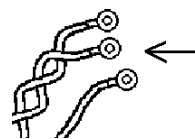

**Remove Power Terminals**

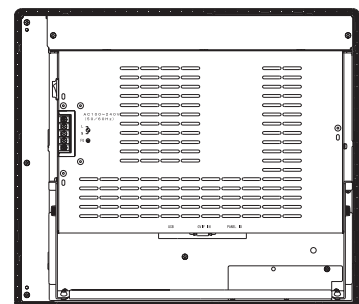

PL-DU7900



## Chapter 5 - Maintenance



- **Be sure to replace the backlight on a flat, level surface. This will prevent damage to the DU unit and the accidental cutting of any of its power cord terminals.**
- **The PL-DU7900 has a cover. When replacing the PL-DU7900's backlight, you need to unscrew this cover's two (2) attachment screws and remove it.**

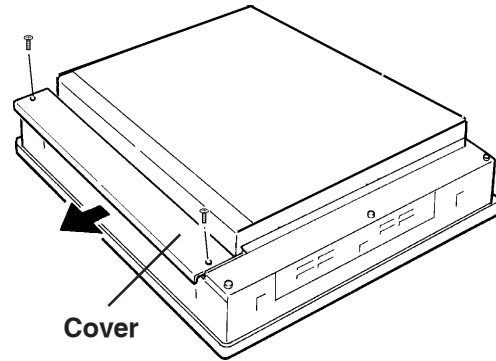

- 3) Remove the DU's four (4) chassis attachment screws.

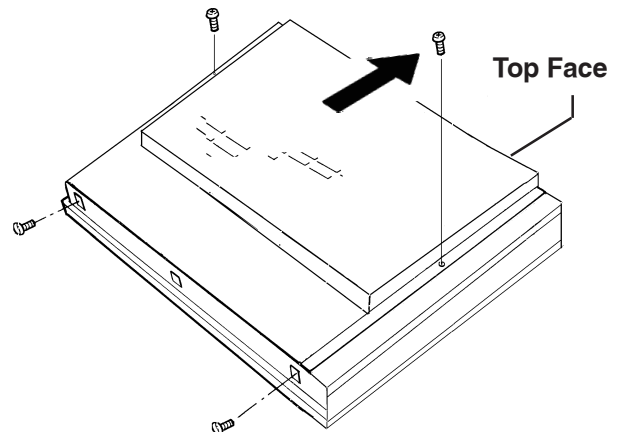

- 4) Hold both sides of the DU's front panel section and use your thumbs to slide (push) the chassis forward in the direction shown here (see figure).

The chassis can then be pivoted back and open. Remove the three (3) attachment screws from inside the Front Unit.

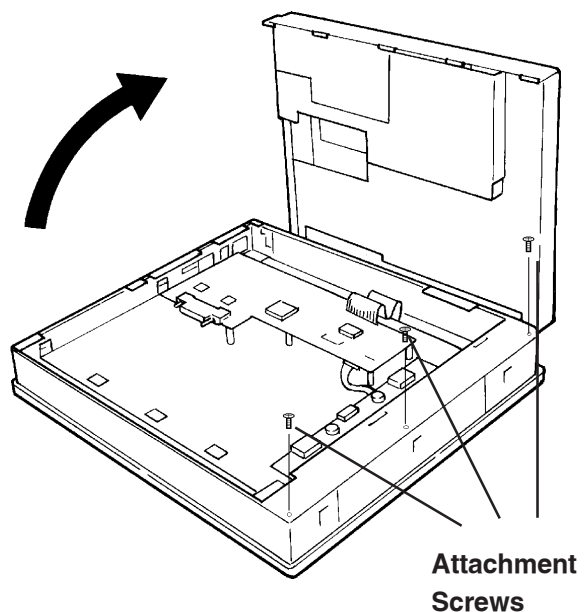

When changing the PL-DU6900 backlight, use steps 5) to 12) on Pages 5-5 to 5-8.

When changing the PL-DU7900 backlight, use steps 5) to 14) on pages 5-8 to 5-9.

## ■ When Changing the PL-DU6900 Backlight

- 5) Disconnect both backlight power connectors from the inverter board.

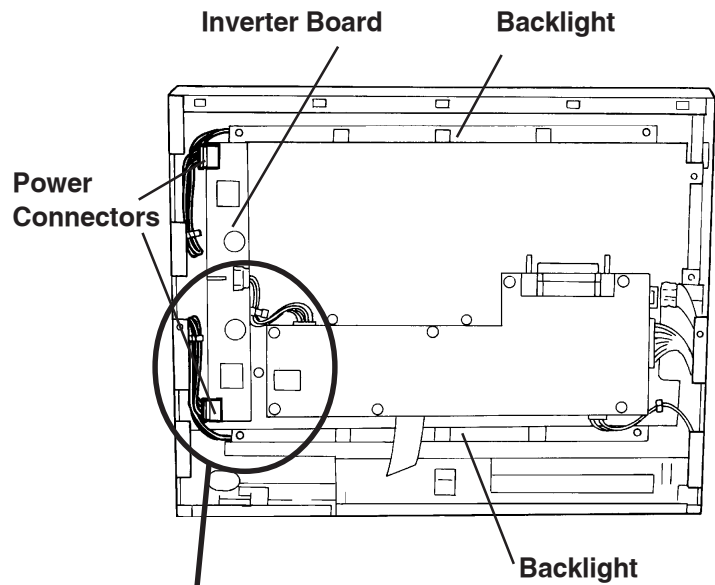

- 6) Each backlight (upper and lower) is fixed in place with two (2) attachment screws. Remove these 4 screws.

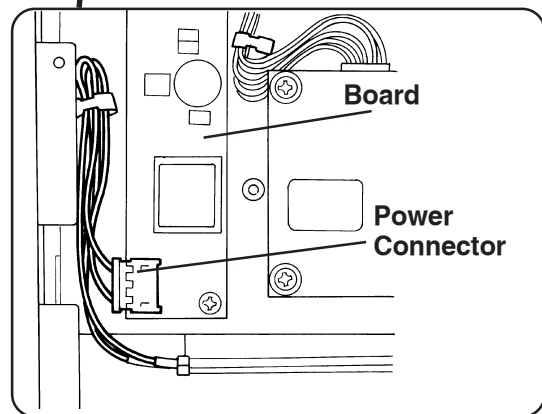

- **Use an "0" sized Phillips screwdriver to remove the backlight attachment screws.**
- **Be careful not to lose any of the small attachment screws.**
- **Do not let any attachment screws fall inside the DU unit's chassis or front panel area, since it could cause an electrical short when the DU's power is turned ON again.**

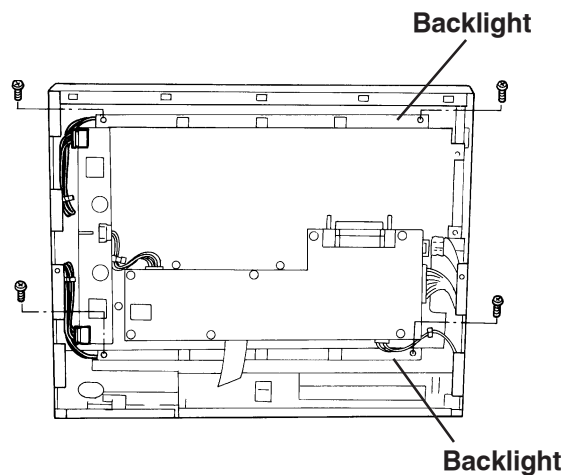

## Chapter 5 - Maintenance

- 7) Open/release each plastic cable holder.



**Note:** Each backlight uses a cable holder to prevent the cable from becoming caught or pinched when the DU's rear cover is opened or closed. Be sure both cables are secured by their holder before closing the rear cover.

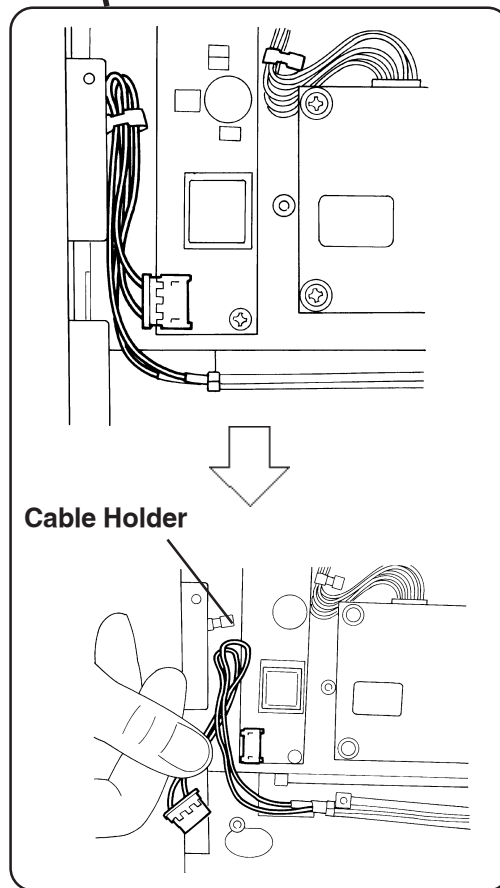
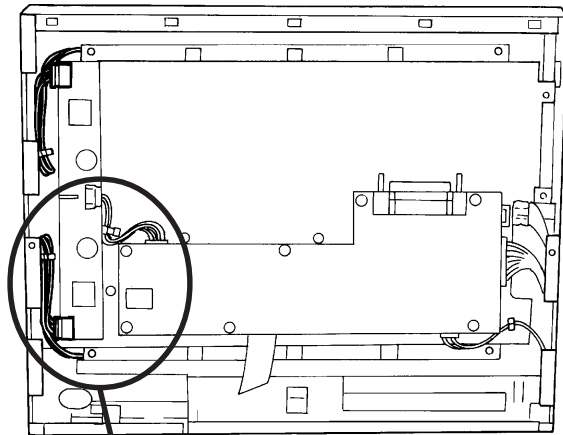

- 8) Remove each backlight unit.
- 9) Insert each new backlight.  
Be sure to hold the new backlights with the metal clips.
- 10) After installing both new backlights using steps 7) to 9), replace and tighten all attachment screws (total of 4 screws). Then, re-connect both board power connectors.

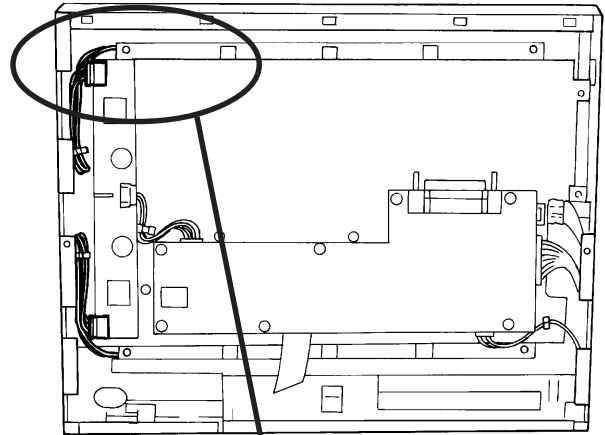

- ***Be sure to always change both DU backlights at the same time.***
- ***Be sure that the backlight's power cord connector is inserted completely into the board's receptacle. If not, the DU may be damaged.***

- 11) Reattach the rear cover, being careful not to pinch any internal electrical wires.
- 12) Replace and tighten the DU Rear face's four (4) chassis attachment screws.

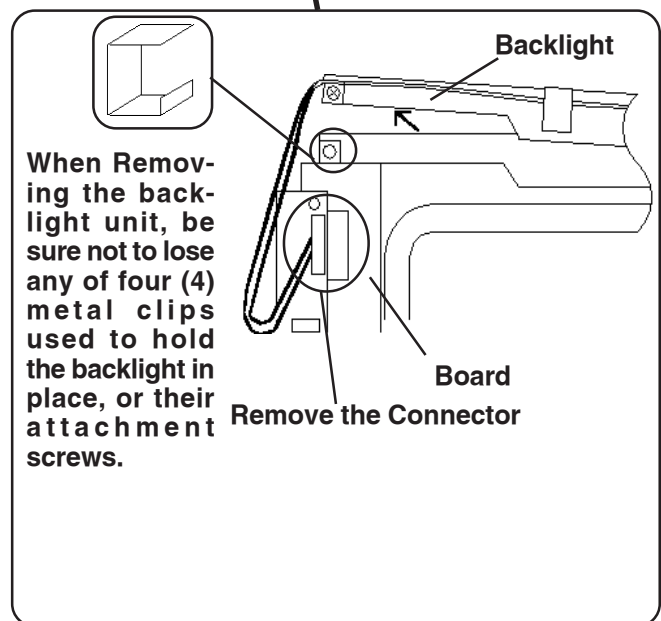

## Chapter 5 - Maintenance

### ■ When Changing the PL-DU7900 Backlight

5) The DU's LCD display unit is fixed in place with two (2) attachment screws. Remove these screws.

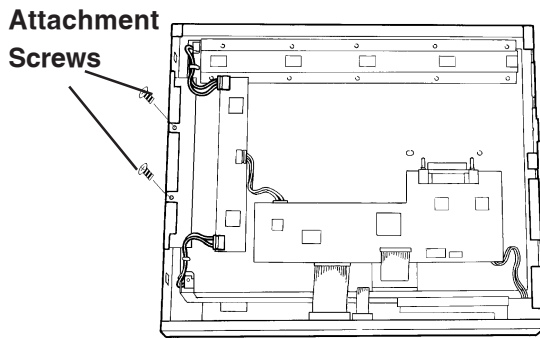

6) Disconnect both backlight power connectors from the Invertor Board.

7) Each backlight (upper and lower) is fixed in place with two (2) attachment screws. Remove each of these screws.

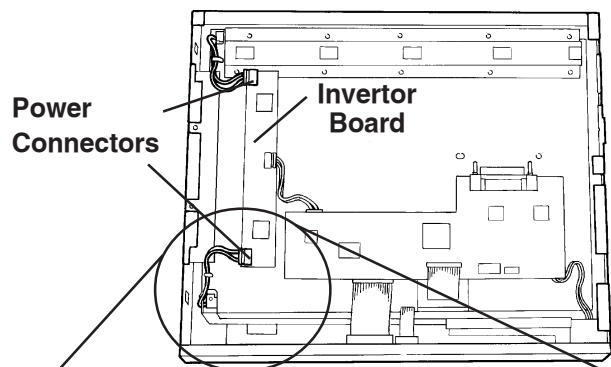

• **Use a "1" sized Phillips screwdriver to remove the backlight attachment screws.**

• **Be careful not to lose any of the small attachment screws.**

• **Do not let any of attachment screws fall inside the DU unit's chassis or front panel area, since it could cause an electrical short when the DU's power is turned ON again.**

8) Open/release each plastic cable holder.

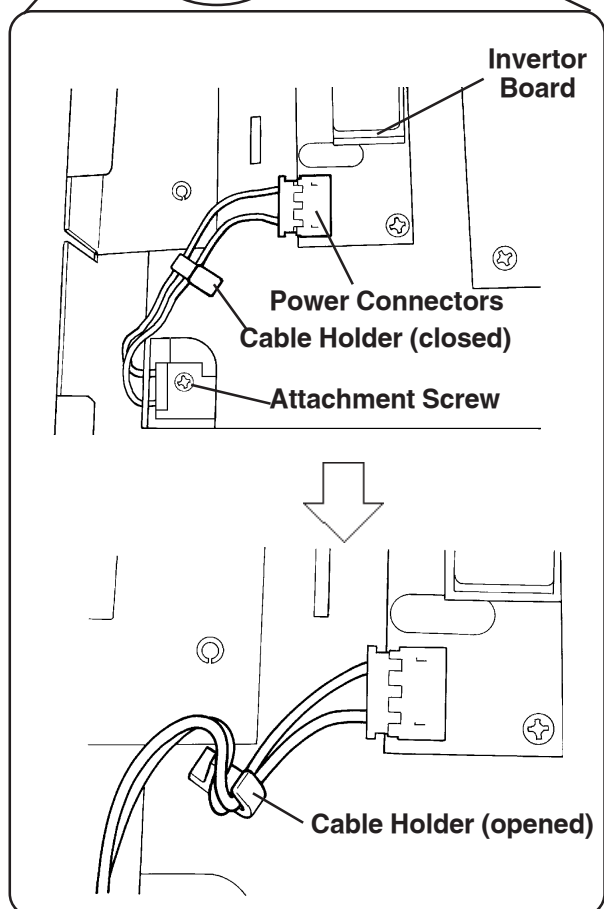

Each backlight uses a cable holder to prevent the cable from becoming caught or pinched when the DU's rear cover is opened or closed. Be sure both cables are secured by their holder before closing the rear cover.

- 9) Remove each backlight unit.
- 10) Insert each new backlight.
- 11) After installing both new backlights using steps 8) to 10), replace and tighten all backlight and LCD panel attachment screws (total of 4 (4) screws). Then, re-connect both board power connectors.

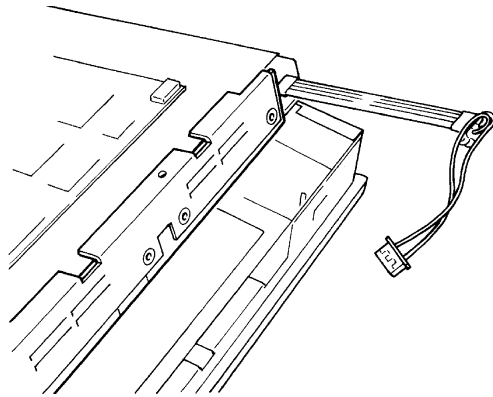

**important**

- ***Be sure to always change both DU backlights at the same time.***
  - ***Be sure that the backlight's power cord connector is inserted completely into the board's receptacle. If not, the DU may be damaged.***
- 12) Reattach the rear cover, being careful not to pinch any internal electrical wires.
  - 13) Replace and tighten the DU's four chassis attachment screws.

### 5.3 Periodic Check Points

---

To keep your DU unit in good working condition, please check the following points periodically.

#### **DU Operation Environment**

- Is the operating temperature within the allowable range?
- Is the operating humidity within the specified range (10% RH to 85% RH)?
- Is the operating atmosphere free of any corrosive gasses?

#### **Electrical Specifications**

- Is the input voltage appropriate (AC85V to AC265V 50/60Hz) ?

#### **Related Items**

- Are all cables connected properly? Have any become loose?
- Are all installation fasteners holding the unit securely?
- Are there many scratches or traces of dirt on the moisture resistant gasket?

#### **Display Check**

- Is the display bright enough ?



**Note:** When the DU's backlight needs to be replaced, please contact your local DU distributor.

# Index

<b>A</b>	Accessories ..... E1-3	<b>I</b>	Icon Meaning ..... E2 Insert the DU into the Installation Slot E4-3, E4-4, E4-5 Installation ..... E3-1 Installation and Wiring ..... E4-1 Installation Cautions ..... E4-1 Installation Fasteners ..... E2-6 Installation Gasket ..... E4-2 Installation Gasket Replacement ..... E5-1 Installation Positioning Cautions ..... E4-1 Introduction ..... E1-1 IrDA ..... E2-4
<b>B</b>	backlight type ..... E5-2 Brightness Adjustment Slide ..... E2-4	<b>L</b>	LCD Handling Caution ..... E4 LCD Usage and Handling ..... E5
<b>C</b>	CE Marking Notes ..... E10 Changing the Backlight ..... E5-2 Cleaning the Display ..... E5-1 Connecting I/O Signal Lines ..... E4-8 Connecting the DU's Power Supply ..... E4-7 Connecting the Power Cord ..... E4-5 Connecting to PL ..... E4-5 Crimp Terminal Types ..... E4-6	<b>M</b>	Maintenance ..... E5-1 Moisture Resistant Gasket ..... E4-2 Moisture Resistant Gasket Replacement ..... E4-2, E5-1 moisture resistant seal ..... E4-2
<b>D</b>	Display Area ..... E2-4 Display Specifications ..... E2-3 Display Unit Dimensions ..... E2-5 DU Installation ..... E3-1, E4-2	<b>N</b>	Names and Functions ..... E2-4
<b>E</b>	electric hazards ..... E3-1 Electrical Specifications ..... E2-1 Environmental Specifications ..... E2-1 Essential Safety Precautions ..... E2 External Dimensions ..... E2-5	<b>P</b>	Package Contents ..... E9 Panel Installation Opening ..... E4-2 panel thickness ..... E2-6, E4-2 Performance Specifications ..... E2-3 Periodic Check Points ..... E5-9 PL Connector ..... E2-4 Power Input Terminals ..... E4-5 Power Switch ..... E2-4 Power Terminals ..... E2-4 Preface ..... E1 Prior to Using the DU ..... E6
<b>F</b>	Front Maintenance Cover ..... E2-4 Functional Specifications ..... E2-3	<b>R</b>	Regular Cleaning ..... E5-1
<b>G</b>	General Safety Precautions ..... E5 General Specifications ..... E2-1 Grounding ..... E2-2, E4-8		
<b>H</b>	Hardware Reset Switch ..... E2-4		



# Index

## S

Shock / Vibration Related Cautions .....	E4-1
Specifications .....	E2-1
Status LED .....	E2-4
Structural Specifications .....	E2-2
System Design .....	E1-1

## T

Table of Contents .....	E12
Temperature Related Cautions .....	E3-2, E4-1
Touch Panel .....	E2-4

## U

UL/c-UL(CSA) Application Notes .....	E10
--------------------------------------	-----

## V

Viewing Angle .....	E4-3
---------------------	------

## W

Wiring Cautions .....	E4-5
-----------------------	------