

PL-FD500

Installation Guide

The PL-FD500 is an internally mounted 3.5 inch floppy disc drive unit, designed for use with Proface's Panel Computer, PL-5900/PL-5910 Series Units, hereafter referred to as the "PL."

Corresponding Product : PL-5900/PL-5910 Series Units

All product names used in this document are the trademarks of their respective manufacturers.

Pro-face : Digital Electronics Corporation

WARNINGS

- Be sure to confirm that the PL unit's power cord is disconnected prior to installing the FDD unit, in order to prevent electrical shock.
- Do not attempt to modify the FDD unit, due to the danger of fire or electrical shock.
- Prior to installing the FDD unit, be sure to read section "2. Installation" completely to insure that this unit is correctly installed.
- The PL is not appropriate for use with aircraft control devices, aerospace equipment, central trunk data transmission (communication) devices, nuclear power control devices, or medical life support equipment, due to these devices inherent requirements of extremely high levels of safety and reliability.
- When using the PL with transportation vehicles (trains, cars and ships), disaster and crime prevention devices, various types of safety equipment, non-life support related medical devices, etc. redundant and/or failsafe system designs should be used to ensure the proper degree of reliability and safety.

To prevent this unit from malfunctioning :

- Since the FDD unit is a precision instrument, be sure that it is neither hit by nor pressed strongly against another object.
- Be sure that water, liquids, or metal particles are not allowed to contact or enter this unit. Either of these may cause either a breakdown or an electrical shock.
- Do not install or operate this unit in a location where there is direct sunlight, excessive heat, dust or vibration.
- Do not store or operate this unit near chemicals, or where there are chemical fumes.
- To prevent damage to file data, be sure to shut down the PL unit's OS before turning OFF the main power.

Package Contents

When you open the FDD unit's package, please check immediately that the following items are included.

■ **PL-FD500 (1)**

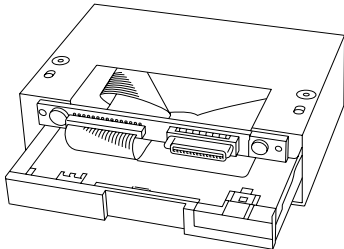

■ **PL-FD500 Installation Guide (This Guide) (1)**

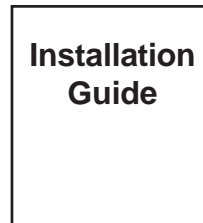

■ **Attachment Screws (4)**



Proface has taken the utmost care to insure the quality of this product when it was shipped. However, should, for any reason, problems or damage have occurred during shipping, please contact your Proface representative immediately for service.

1 Hardware Specifications

■ **Performance**

Operation Mode	2MB mode record/write	1MB mode record/write
Disc Type (3.5 inch)	High density type (2HD)	Double density type (2DD)
Unformatted Data Capacity	2MB	1MB
Data Transfer Speed	500K bits/second	250K bits/second
Disc Rotation Speed	300 rpm	
Track Density	135 tpi	
Track-track Seek Speed	3 ms	
Power Consumption	At start : 0.8A (typ.) At read/write : 0.3A (typ.) During wait : 0.01A (typ.)	
Reliability (MTBF)	30,000 hours	

■ Environmental

Ambient Operating Temperature	5°C to 45°C
Ambient Storage Temperature	-10°C to 60°C
Ambient Humidity	20%RH to 80%RH (no condensation)
Vibration Resistance	(During operation) 9.8m/s ² (10Hz to 25Hz)
Shock Resistance	(During shipping) 980.7m/s ²



- The above specifications are for the FDD unit only.
- Proface does not guarantee the preservation of any data stored on the HDD if the HDD malfunctions or is damaged in any way. Therefore, the regular backing up of important HDD data to either a floppy disk, or other type of suitable magnetic media is strongly recommended.

2 Installation

Be sure to use the following installation procedures to insure that the unit is correctly installed.



WARNING

Shock Danger! Be sure to disconnect the PL unit's power cord prior to installing the FDD Unit.

The FDD unit's installation procedure is different, depending on the PL (main unit) type, i.e. the PL-5900T/PL-5910T or the PL-5901T/PL-5911T. The instructions given in steps 1 to 3 are the same for both the PL-5900T/PL-5910T and the PL-5901T/PL-5911T, however the instructions used from step 4 on are different. After completing step 1 to 3, proceed to the explanation to pertain to your specific PL unit.

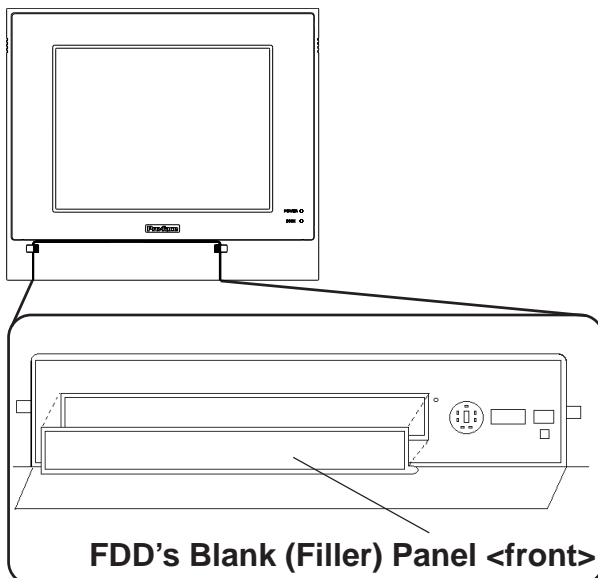

- 1) Open the front maintenance cover and remove the FDD's blank (filler) panel.
- 2) Close the front maintenance cover.

FDD's Rear Blank (Filler) Panel

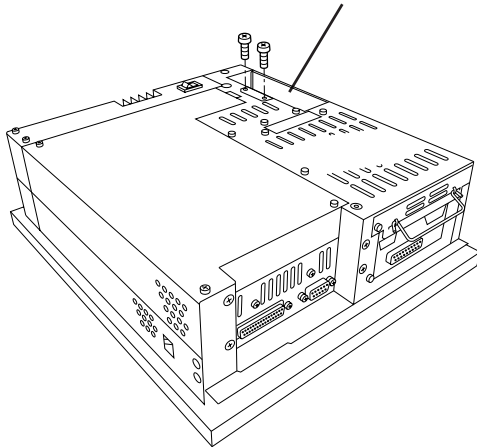

- 3) Unscrew the two rear face Blank Panel attachment screws, and remove the Blank Panel.

■PL-5900T/PL-5910T (3 Slot Type)

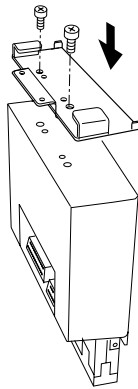

- 4) Attach the Blank Panel removed in step 3) to the FDD unit, using its two (2) attachment screws. (Do not use the bracket that comes with the FDD unit.)

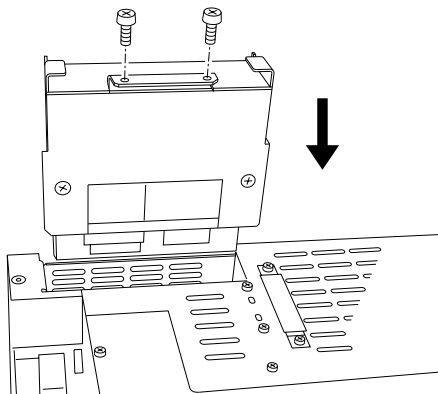

- 5) Insert the FDD unit into the PL. Be sure the connectors of the PL and the FDD unit are securely connected.

- 6) Attach the FDD unit to the PL using the FDD unit's four (4) attachment screws. – This includes the two (2) PL bottom face attachment screws.

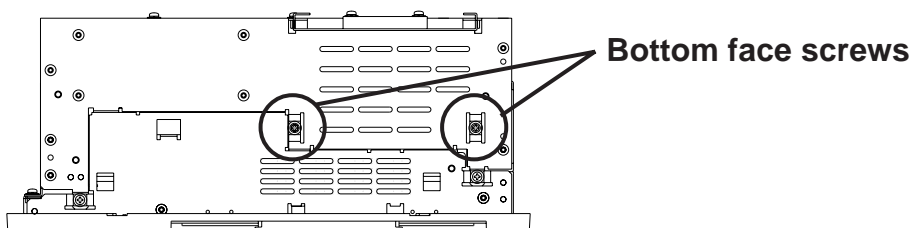

■PL-5901T /PL-5911T(1 Slot Type)

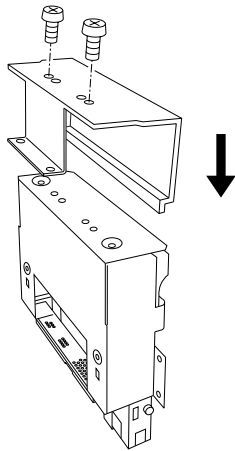

4) Attach the bracket that comes with the FDD unit to the FDD unit and secure it with the two (2) attachment screws. (Do not use the bracket removed in step 3).

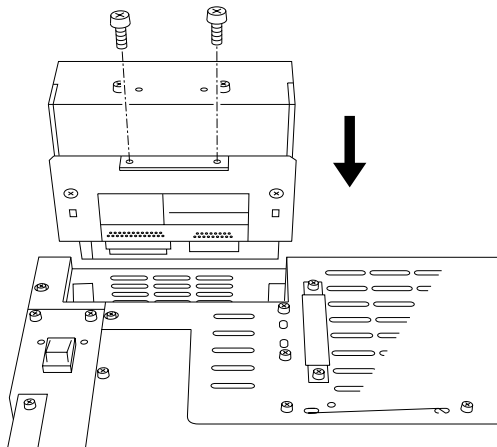

5) Insert the FDD unit into the PL. Be sure the connectors of the PL and the FDD unit are securely connected.

6) Attach the FDD unit to the PL using the FDD unit's four (4) attachment screws. – This includes the two (2) PL bottom face attachment screws.

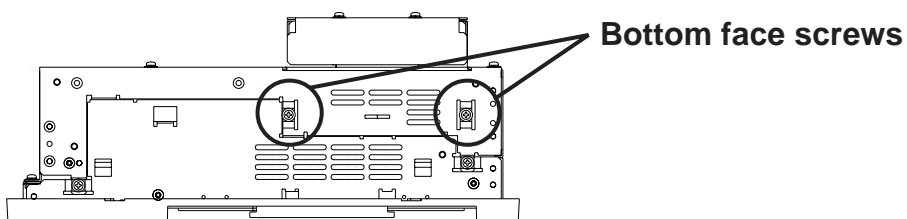

Note: Even after the unit is securely attached to the PL, part of the unit will extend out from the PL.

3 Hardware Setup

Use the following steps to setup the hardware. Even though the BIOS screen shown below is for PL-5900 Series unit, the PL-5910 Series setup procedures is the same.



Certain BIOS screen items may differ from those shown here due to new versions.

- 1) Connect a keyboard to the PL.
- 2) Turn the PL's power ON.
- 3) After the message, "Press to Enter SETUP" appears at the left bottom of the screen, hold down the [DEL] key.

The setup utility will start and the following screen will appear.

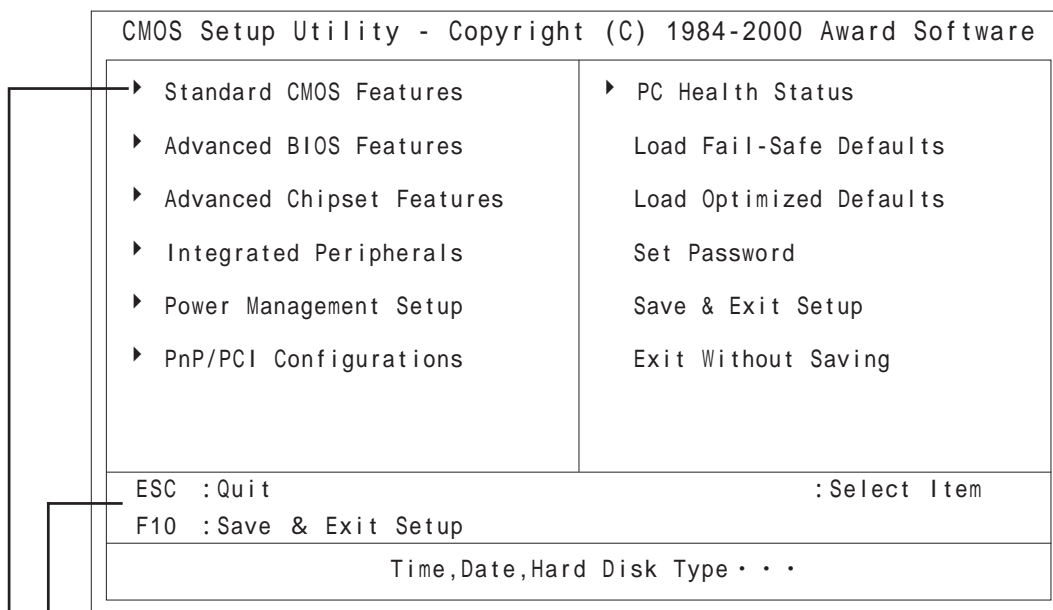

Operation Keys

Provides a list of keys used for setup procedures.

System Setting Areas

Each selection item shown here represents a separate menu area, where settings can be entered.

- 4) Use the cursor to select "STANDARD CMOS SETUP," and the following screen will appear.

CMOS Setup Utility - Copyright (C) 1984-2000 Award Software Standard CMOS Features		Item Help
Date (mm:dd:yy):	Thu, Aug 24 2000	Menu Level ▶ Change the day, month, year and century
Time (hh:mm:ss):	11 : 15 : 14	
▶ IDE Primary Master	Press Enter 10056 MB	
▶ IDE Primary Slave	Press Enter None	
Drive A	1.44M, 3.5 in.	
Drive B	None	
Video	EGA/VGA	
Halt On	All,But Keyboard	
Base Memory	640K	
Exterded Memory	56320K	
Total Memory	57344K	
:Move Enter:Select +/-/PU/PD:Value F10:Save ESC:Exit F1:General Help F5:Previous Values F6:Fail-Safe Defaults F7:Optimized Defaults		

- 5) Confirm that “Drive A:” is set to “1.44M, 3.5 in.” If the setting is different, place the cursor on the “Drive A:” selection item and use the [PU], [PD] or [+], [-] key to select the “1.44M, 3.5 in.” drive setting.
- 6) Press the [ESC] key, and the initial (main) menu screen will appear.
- 7) Place the cursor on the “SAVE & EXIT SETUP” selection item and press the [Enter] key.
- 8) After the “SAVE to CMOS and EXIT (Y/N)? N” message appears, press the [Y] key to quit the setup utility.

Note

Be aware that the Digital Electronics Corporation shall not be held liable for any real or estimated damages or losses, or third party claims resulting from the use of this product.