

# Preface

Thank you for purchasing Digital's TFT type color display panel, the 'FP-770T'(hereafter referred to as "the FP").

The FP is a TFT type color liquid crystal display monitor for IBM-PC compatible personal computers (VGA, XGA and SVGA modes).

Please read this manual completely to insure the correct use and complete understanding of the FP's functions.

The FP's analog interface is designed to comply with VESA standards. Please be aware that this unit may not be able to be connected with devices using nonstandard VGA interfaces. For further information, please refer to this chapter's "PC Connection Notes" section.

## <Note>

- 1) It is forbidden to copy the contents of this manual, in whole or in part, except for the user's personal use, without the express permission of the Digital Electronics Corporation of Japan.
- 2) The information provided in this manual is subject to change without notice.
- 3) This manual has been written with care and attention to detail; however, should you find any errors or omissions, please contact the Digital Electronics Corporation and inform them of your findings.
- 4) Please be aware that the Digital Electronics Corporation is not responsible for any damages resulting from the use of our products, regardless of article 3 above.

All Company/Manufacturer names used in this manual are the registered trademarks of their respective companies.

© Copyright 1998 Digital Electronics Corporation

# Safety Symbols

This section describes the safety precautions necessary for the correct use of the FP. Please keep this manual close at hand and refer to it when necessary.

## ■ Safety Symbol Types

The following symbols are used throughout this manual to ensure the safe use of the FP. Please be sure to follow all instructions given since they explain important safety points.



This mark warns of a situation that could cause either serious or fatal injury if the instruction is ignored and/or the unit is used incorrectly.



This mark warns of a situation that could cause either personal injury or property damage if the instruction is ignored and/or the unit is used incorrectly.



# Safety Instructions

For the safe use of this unit, be sure to follow these guidelines:

- Because of the danger of electrical shock, be sure to unplug (disconnect) the power cable from the FP before plugging the cable's other end into the power supply.
- Do not use power in excess of the unit's specified voltage range since it may cause a fire, an electrical shock, or damage the unit.
- Because the FP contains high voltage parts, an electric shock can occur when disassembling the unit. Therefore, be sure to always unplug the unit before disassembling it.
- Do not modify the FP in any way, since it may cause either a fire or an electrical shock.
- When changing the backlight, be sure to turn off the unit's power first, to prevent an electric shock.
- Do not use touch panel keys to perform life-threatening or vitally important safety functions. Use separate hardware switches to provide machine emergency stop or other safety functions.
- If substantial amounts of metallic dust, water or liquids enter the FP's case, turn off the FP's power immediately, unplug the power cord, and contact your local FP distributor.
- When installing the FP, be sure to follow the instructions given in "Chapter 3. Installation and Wiring," to insure it is performed correctly.
- Do not use the FP in an environment with flammable gas since it may cause an explosion.
- The FP is not intended for applications requiring extremely-high reliability and safety, such as aircraft equipment, aerospace equipment, central communication equipment, nuclear control equipment or life-supporting medical equipment.
- When the FP is used for equipment that must provide high reliability and safety in its functions and accuracy, the entire system that uses the FP must have its safety features designed to include redundancy and error-prevention.  
Examples of such usage are: transportation (trains, automobiles, ships, etc.), disaster/crime-prevention devices, numerous safety devices, and medical equipment not related to life support.



## Safety Instructions

For the correct use of this unit, please follow these guidelines:

- Do not press the screen's touch surface too strongly with either your finger or a hard object, since the touch surface may be damaged.
- Do not press on the touch panel's face with sharp objects, such as a mechanical pencil or a screwdriver, since it can damage the panel surface.
- When the surface of the display screen becomes dirty or smudged, clean the display with a cloth soaked in a neutral detergent. Do not use paint thinner or organic solvent.
- Avoid using or storing the FP in direct sunlight, excessively dusty or dirty environments, or where chemicals or their vapors are present in the air.
- Please avoid using the FP in areas where sudden, large changes in temperature may occur. These changes can cause condensation to form inside the unit, possibly causing an accident.
- Avoid restricting the FP's natural ventilation, or storing and using the FP in an environment that will raise the FP's internal temperature above its designated limits.
- Do not use or store the FP in areas where chemical vapors are present or where chemicals may come into contact the unit.

### Notes on the FP's Liquid Crystal Display (LCD)

---

- There are minute grid-points on the LCD surface. These points are not defects.
- The displayed color will look different when viewed from an angle outside the specified view angle. This phenomenon is a common attribute of LCD's and is not a defect.
- Displaying a single screen image for long periods of time can cause an afterimage to remain on the screen. To correct this, turn the unit OFF for a short period (5 to 10 minutes), then ON again. This phenomenon is a common attribute of the LCDs, and not a defect. To prevent the creation of an afterimage, you can change the screen display periodically to prevent the displaying of a single image for a long period of time.

## UL Application Notes

The FP-770 is a (c)UL 1950 recognized product. (UL File No.190533). Please pay special attention to the following instructions when applying for UL approval for machinery which includes one of these FP units built in. Machinery with an FP unit mounted in it requires UL inspection for the combination of the FP and the machinery.

- The FP-770T conforms as a component to the following standards:
  - UL 1950, Third Edition, dated April 30, 1998 (Standard for Safety of Information Technology Equipment, including Electrical Business Equipment)
  - CSA-C22.2 No. 950-M95 (Standard for Safety of Information Technology Equipment, including Electrical Business Equipment)
  - FP-770T (UL Registration Model No.: 0880047)
  
- If the FP is installed so as to cool itself naturally, be sure to install the unit in a vertical position. Also, be sure that the FP is installed so that it is at least 100mm away from any adjacent structures or devices. If these requirements are not met, the heat generated by the PL's internal components may cause the unit to fail to meet UL standard requirements.

## CE Marking Notes

The FP-770T is a CE marked, EC compliant product.

**<Complies with the following EC Directives>**

EMC Directives 89/336/EEC, 92/31/EEC, 93/68/EEC

Low Voltage Directives 73/23/EEC, 93/68/EEC

**<Complies with the following Standards>**

■ **Safety**

EN60950/A2:1993), VDE 0805/A2:1994

■ **EMI (EN50081-2)**

EN55022:1994(Class A), EN61000-3-2:1995, EN61000-3-3:1995

■ **EMS (EN50082-2)**

EN61000-4-2 :1995, EN61000-4-4:1995, EN61000-4-5:1995,

EN61000-4-11:1995, ENV50204:1995, ENV50140:1993,

ENV50141:1993

# Table of Contents

Preface .....	i
For the Safe And Correct Use of this Unit .....	ii
Warning: Safety Instructions .....	iii
Caution: Safety Instructions .....	iv
UL Application/CE Marking Notes .....	v
Table of Contents .....	vi
PC Connection Notes .....	viii
FP-770T Features .....	ix
Package Contents .....	x
Manual Symbol Information .....	xi

## Chapter 1—Introduction

1-1 Connecting the FP to a PC .....	1-1
1-2 Optional Equipment .....	1-3

## Chapter 2—Specifications

2-1 General Specifications .....	2-1
1 Electrical Specifications .....	2-1
2 Environment Specifications .....	2-1
3 Structural Specifications .....	2-2
2-2 Functional Specifications .....	2-2
2-3 Interface Specifications .....	2-3
1 Analog RGB Interface .....	2-3
2 Serial Interface .....	2-4
3 Keyboard Interface .....	2-5
4 Mouse Interface .....	2-5
5 PC Interface .....	2-5
2-4 Option Cable Pin Diagrams .....	2-6
2-5 Names and Descriptions of FP Parts .....	2-8
2-6 Flat Panel (FP) Dimensions .....	2-9
1 FP-770T External Dimensions .....	2-9
2 Installation Brackets .....	2-10
3 FP Installation Hole Dimensions .....	2-10

## **Chapter 3—Installation and Wiring**

<b>3-1 Installation</b> .....	<b>3-1</b>
1 Installation Procedures .....	3-1
<b>3-2 Wiring</b> .....	<b>3-4</b>
1 Power Cable Connection Precautions .....	3-4
2 FP Power Cable Connection Procedures .....	3-6
3 FP Power Supply Connection Procedures .....	3-7
4 FP Grounding Cautions .....	3-7
5 FP Input/Output Signal Line Cautions .....	3-7
<b>3-3 Setup of Operation Mode and Positioning of Display</b> .....	<b>3-8</b>
1 Operation Mode Setup and Adjustment .....	3-8

## **Chapter 4—Touch Panel Commands**

<b>4-1 Command List</b> .....	<b>4-1</b>
<b>4-2 Touch Panel Data Input</b> .....	<b>4-3</b>
<b>4-3 Boot-up Initialization</b> .....	<b>4-7</b>

## **Chapter 5—Troubleshooting**

<b>5-1 Troubleshooting</b> .....	<b>5-1</b>
1 Possible Device Problems .....	5-1
2 No Display .....	5-2
3 The Touch Panel Does Not Function .....	5-4

## **Chapter 6—Maintenance**

<b>6-1 Cleaning the FP's Display</b> .....	<b>6-1</b>
<b>6-2 Periodic Check-Up</b> .....	<b>6-2</b>
<b>6-3 Changing the Backlight</b> .....	<b>6-3</b>

# PC Connection Notes

The FP's analog RGB interface offers normal display performance within the following ranges:

VESA standard display mode	Size	Horizontal frequency	Vertical frequency	Dot clock frequency
<b>VGA</b>	640 x 480	31.5 kHz	60 Hz	25.175 MHz $\pm$ 0.4 %
		37.9 kHz	72 Hz	31.500 MHz $\pm$ 0.4 %
		37.5 kHz	75 Hz	31.500 MHz $\pm$ 0.4 %
<b>SVGA</b>	800 x 600	35.1 kHz	56 Hz	36.000 MHz $\pm$ 0.4 %
		37.9 kHz	60 Hz	40.000 MHz $\pm$ 0.4 %
		48.1 kHz	72 Hz	50.000 MHz $\pm$ 0.4 %
		46.9 kHz	75 Hz	49.500 MHz $\pm$ 0.4 %
<b>XGA</b>	1024x 768	48.4 kHz	60 Hz	65.000 MHz $\pm$ 0.4 %
		56.5 kHz	70 Hz	75.000 MHz $\pm$ 0.4 %
		60.0 kHz	75 Hz	78.750 MHz $\pm$ 0.4 %
<b>US Text</b>	720 x 400	31.5 kHz	70 Hz	28.300 MHz $\pm$ 0.4 %

Since some commercially-available video interface equipment also accomodates tracking ranges in excess of those shown above, they may not offer normal display performance when used with the PC. Before using a video interface, be sure to check its specifications.

Also, even if the same type personal computer is used to transfer data to the PC, the above mentioned problems can also occur when the PC's video board is replaced.

The touch panel's PS/2 mouse connector can be used with equipment conforming to PS/2 mouse standards, however specified performance cannot be guaranteed with every PC and mouse combination.

Also, certain restrictions may apply to the touch panel's PS/2 mouse connector depending on the OS being used.

If an extended mouse/keyboard cable is connected through the FP, the FP may not operate normally, depending on the combination of the host and mouse/keyboard or its cable length. In such a case, connect the mouse/keyboard cable directly to the host.

While the FP('s OS) is starting up, please do not touch the screen's touch panel.



# FP-770T Features

- **Large-sized, high-quality color LCD**

The monitor uses a 13.8 inch TFT type color LCD, and the 260,000 display colors allow a wide variety of screen designs. The features of this display are easy-to-read images and text, wide view angle, high contrast, and fast response.
  - **FP's large-sized display is compatible with the XGA mode**

The FP is compatible with XGA mode, allowing a large variety of information to be displayed.
  - **Display mode is automatically selected (Multi-scan)**

The FP's multi-scan feature automatically selects the display mode, according to the host's display mode (VGA, SVGA, XGA or US Test).
  - **PC data can be displayed on the FP**

Since the FP is connected to the host through an analog RGB interface, it can also be easily connected to a personal computer and used as a display.

For the available display modes, see “*PC Connection Notes*”)
- Reference** 
- **Rear-mounting type is designed to be built into other equipment**

The slim and compact body is designed specifically to be built into machine cabinets and panels. Since the FP can be easily used with other equipment, it can be used as a monitor for your PC-based FA or PA system. Also, the FP front panel's moisture resistant gasket provides a dust-proof and drip-proof seal between the FP's front face and the installation panel. Thus, the FP can be used even in harsh industrial environments.
  - **Touch panel can be operated while PLC data is monitored (Standard feature)**

The FP's touch panel is standard equipment and is suitable for monitoring systems that require touch operations. Also, the FP provides two types of interfaces between the touch panel and the host: an RS-232C interface and PS/2 output via the mouse port. These interfaces can be selected according to your system configuration needs.

# Package Contents

The FP's packing box contains the items listed below. Please check to be sure each is included and is not damaged.

**FP unit (FP770-T41)**

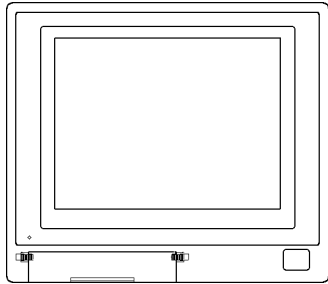

**FP-770T User's Manual**

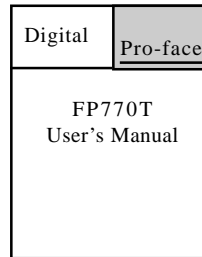

**3.5 inch floppy disk \*1**



**Mounting brackets (12)**

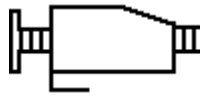

**Moisture-resistant gasket**



**Function key sticker**

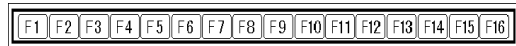

When creating function keys, attach this sticker as shown below.

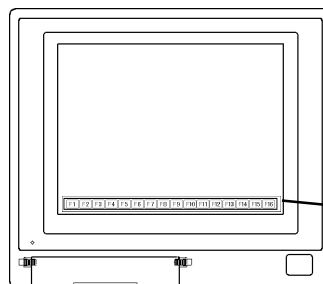

**Attach stickers here**





These items have all been carefully packed with special attention to product quality. However, should you find any item(s) damaged or missing, please contact your local distributor immediately for prompt service.

---

\*1 For description and usage of the application programs stored in the floppy disk, see that disk's English "READM\_E.DOC" file.

# Symbol Information

The list below describes the symbols used in this manual.

Symbol	Meaning
 <b>Warning</b>	Used to indicate situations where severe bodily injury, death or major machine damage can occur.
 <b>Caution</b>	Used to indicate situations where slight bodily injury or machine damage can occur.
 <b>Important</b>	Used to indicate important information or procedures that <u>must</u> be followed for correct and risk-free software/device operation.
*1	Footnote marker used to provide useful or important supplemental information.
1) , 2)	Indicates steps in a procedure. Be sure to perform these steps in the order given.
	Used to refer to useful or important supplemental information.
 <b>Note:</b>	Used to provide useful or important supplemental information.
<b>GP Screen Editor</b>	Indicates the GP-PRO/PBIII or GP-PRO/PBIII for Windows 95 screen editor software.
<b>PLC</b>	Abbreviation for Programmable Logic Controller.
<b>n:1</b>	Indicates a multi-link type of connection is used.

# *MEMO*

# Chapter 1

## Introduction

1. Connecting the FP to a PC
2. Optional Equipment

The following diagram illustrates the connection options available between the FP and a PC.

<b>1-1</b>	<b>Connecting the FP to a PC</b>
------------	----------------------------------

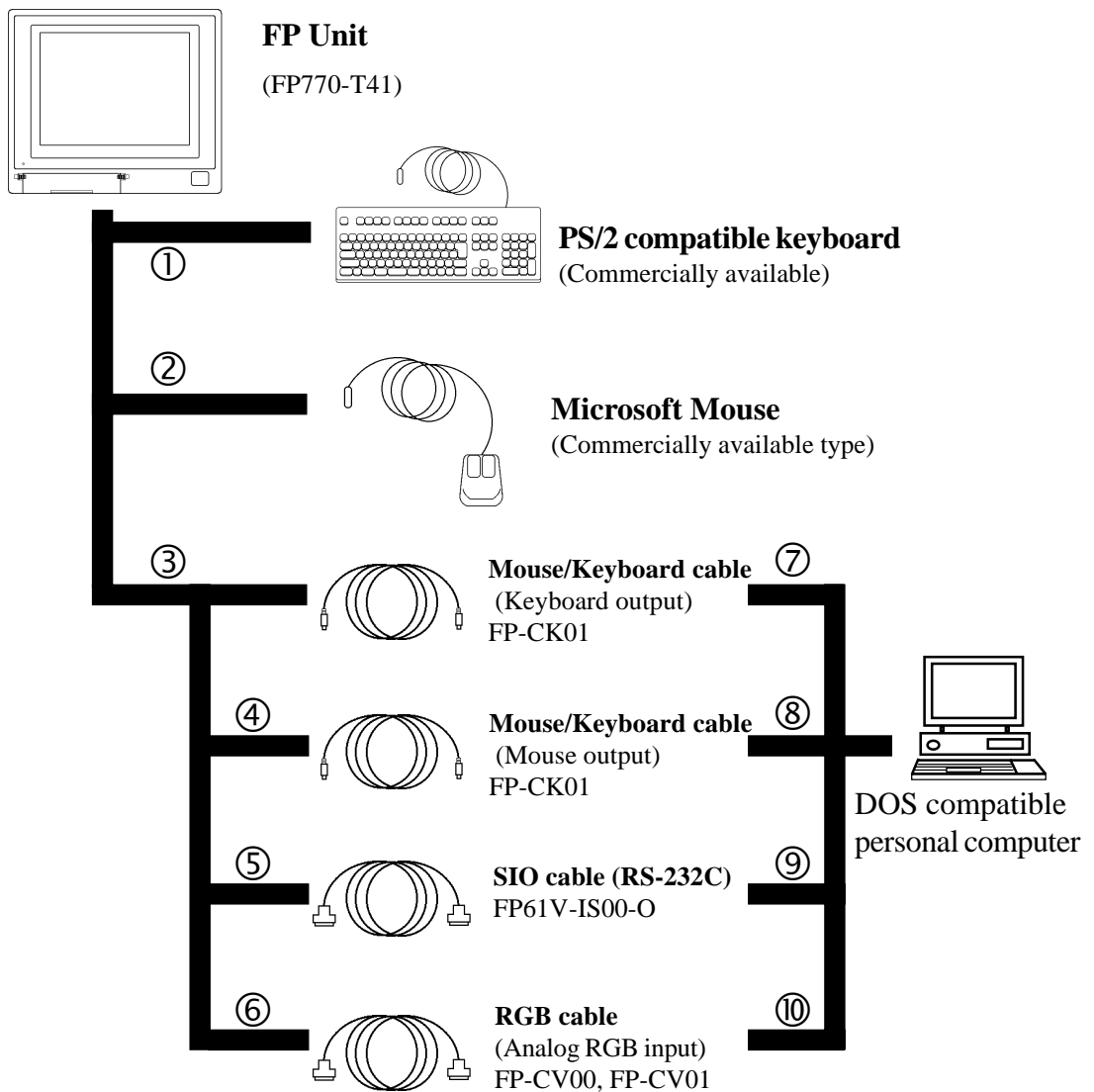

**Reference** For a description of each reference no. used (⑥, etc.) refer to the next page (page 1-2)

## Optional Parts

(Sold separately)



Display Protection Sheets (5 sheets/set)  
FP77-COVER-5P

## Optional Maintenance Parts

These parts are included in either the FP or its package as standard equipment, and are also optionally available for FP maintenance.

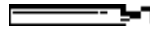

Backlight (2 lights/set)  
FP770T-BL00-MS

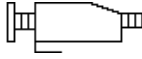

Mounting Brackets (4 brackets/set)  
GP070-AT00-MS



Moisture-Resistant Gasket  
FP77-WP00-MS

### Page 1-1 Item Description

#### FP interface

- ① KEYBOARD/Keyboard
- ② MOUSE/Mouse
- ③ KEYBOARD/PC
- ④ MOUSE/PC
- ⑤ RS-232C connector
- ⑥ Analog RGB I/F connector

**Reference** 2-5 Names and Functions of FP Parts

#### Personal computer interface

- ⑦ Keyboard interface
- ⑧ Mouse interface
- ⑨ Serial interface
- ⑩ Analog RGB interface

## Introduction

<b>1-2</b>	<b>Optional Equipment</b>
------------	---------------------------

All optional equipment listed below are products of Digital Electronics Corp.

	Item Name	Model No.	Description
<b>Interface</b>	SIO cable	FP61V-IS00-O	Serial interface cable used for transmission of touch panel data between the FP and various hosts (PCs), and for the transmission of commands to the FP. (5 m) Compatible with PC/AT (D-sub 9-pin female connector) computers
	RGB cable	FP-CV00	Analog RGB interface cable used to output image signals from various host (PCs) to the FP. (2.5 m) Compatible with analog RGB interface (D-sub 15-pin male connector).
	RGB cable	FP-CV01	Analog RGB interface cable used to output image signals from various host (PCs) to the FP. (5 m) Compatible with analog RGB interface (D-sub 15-pin male connector).
	Mouse/Keyboard cable	FP-CK01	Used to connect a mouse or keyboard between the host and the FP. (2.5 m) Compatible with PS-2 (mini DIN 4-pin male connector) devices
<b>Maintenance Parts</b>	Backlight	FP770T-BL00-MS	Replacement Backlights (2 lights/set)
	Mounting brackets	GP070-AT00-MS	Used to secure the FP to its installation panel. (4 brackets/set)
	Moisture resistant gasket	FP77-WP00-MS	Used to prevent moisture from entering the FP's chassis. Same gasket as originally included with the FP.
<b>Optional Parts</b>	Display protection sheets	FP77-COVER-5P	Disposable sheets that protect the display from dust and dirt. The touch panel can be used when one of these sheets is attached. (5 sheets/set)





# Chapter 2

## Specifications

1. General Specifications
2. Functional Specifications
3. Interface Specifications
4. Option Cable Pin Diagrams
5. Names and Descriptions of FP Parts
6. Flat Panel (FP) Dimensions

This chapter includes general specifications, functional specifications, interface specifications, and part names and dimensions of the FP.

<b>2-1</b>	<b>General Specifications</b>
------------	-------------------------------

### 2-1-1 Electrical Specifications

<b>Input Voltage</b>	AC 85 V to 265 V 50/60 Hz
<b>Power Consumption</b>	Less than 65 VA
<b>Allowable Power Failure</b>	Within 20 ms
<b>Maximum Voltage</b>	AC 1500 V 20 mA 1 minute (between the live wire and grounding terminals)
<b>Isolation Resistance</b>	DC 500 V greater than 10 M $\Omega$ (between the live wire and grounding terminals)

### 2-1-2 Environment Specifications

<b>Operating Temperature</b>	0 to 40 degrees Celsius
<b>Storage Temperature</b>	- 10 to 60 degrees Celsius
<b>Ambient Humidity</b>	30 to 85 % RH (non-condensing)
<b>Vibration Resistance</b>	2 Gs at 10 to 25 Hz (X, Y, Z directions: 30 minutes each)
<b>Atmosphere</b>	Must be free of corrosive gas
<b>Noise</b>	Noise voltage : 1500 Vp-p
	Pulse length : 50 ns/500 ns/ 1 $\mu$ .s
	Arise time (rise/fall): 1 ns
<b>Grounding</b>	Meets Class 3 requirements
<b>Rating<sup>*1</sup></b> (with front panel closed)	Equivalent to IP65f (JEM1030)

\*1 (See the next page's note)

\*1 (Continued from previous page)

*The front face of the GP unit, installed in a solid panel, has been tested using conditions equivalent to the standard shown in the specification. Even though the GP unit's level of resistance is equivalent to the standard, oils that should have no effect on the GP can possibly harm the unit. This can occur in areas where either vaporized oils are present, or where low viscosity cutting oils are allowed to adhere to the unit for long periods of time. If the GP's front face protection sheet becomes peeled off, these conditions can lead to the ingress of oil into the GP and separate protection measures are suggested. Also, if non-approved oils are present, it may cause deformation or corrosion of the front panel's plastic cover. Therefore, prior to installing the GP be sure to confirm the type of conditions that will be present in the GP's operating environment.*

*If the installation gasket is used for a long period of time, or if the unit and its gasket are removed from the panel, the original level of the protection cannot be guaranteed. To maintain the original protection level, you need to replace the installation gasket regularly.*

### 2-1-3 Structural Specifications

<b>External Dimensions (mm)</b>	405 W × 350 H × 75 D (Unit only, including rear projections)
<b>Weight</b>	6.5 kg or less (Unit only)
<b>Cooling System</b>	Natural air circulation

### 2-2 Functional Specifications

<b>Display Media</b>	TFT color LCD
<b>Display Colors</b>	260,000
<b>Contrast Adjustment</b>	Possible via adjustment menu
<b>Dot Pitch (mm)</b>	0.273 W × 0.273 H
<b>Touch Panel Resolution</b>	1024 × 1024
<b>Display Area (mm)</b>	279 W × 209 H
<b>Display Mode (selected with a switch)</b>	640 × 480 (VGA) 720 × 400 (US Text) 800 × 600 (SVGA) 1024 × 768 (XGA)
<b>Interfaces</b>	Analog RGB input, RS-232C input, PS/2 input and output (both mouse and keyboard)
<b>Backlight</b>	CFL (under continuous 24 hour operation, lifespan = 10,000 hours)

# Specifications

## 2-3 Interface Specifications



**Please use Digital's optional cable. If any other cable is used, due to possible noise interference, Digital cannot guarantee the FP will perform as specified.**

### 2-3-1 Analog RGB Interface

<b>Input signal type</b>	<b>Analog RGB</b>
<b>Input signal characteristics</b>	Image signal : analog RGB Synchronous signal : TTL level, negative true or positive true Scanning type : non-interlaced
<b>Adjustment features</b>	Flicker adjustment (PHASE, CLOCK) Contrast adjustment BRIGHT (Brightness) adjustment Color adjustment (R,G,B) Horizontal display positioning Vertical display positioning

VESA standard display mode	Size	Horizontal frequency	Vertical frequency	Dot clock frequency
<b>VGA</b>	640 × 480	31.5 kHz	60 Hz	25.175MHz ± 0.4 %
		37.9 kHz	72 Hz	31.500MHz ± 0.4 %
		37.5 kHz	75 Hz	31.500MHz ± 0.4 %
<b>SVGA</b>	800 × 600	35.1 kHz	56 Hz	36.000MHz ± 0.4 %
		37.9 kHz	60 Hz	40.000MHz ± 0.4 %
		48.1 kHz	72 Hz	50.000MHz ± 0.4 %
		46.9 kHz	75 Hz	49.500MHz ± 0.4 %
<b>XGA</b>	1024 × 768	48.4 kHz	60 Hz	65.000MHz ± 0.4 %
		56.5 kHz	70 Hz	75.000MHz ± 0.4 %
		60.0 kHz	75 Hz	78.750MHz ± 0.4 %
<b>US Text</b>	720 × 400	31.5 kHz	70 Hz	28.300MHz ± 0.4 %

### Pin Assignments and Signal Names for Analog RGB Connector

Pin No.	Signal Name	Condition	Pin Location
1	Analog R	R signal input	
2	Analog G	G signal input	
3	Analog B	B signal input	
4	Reserved	NC (reserved for input)	
5	Digital Ground	Digital signal GND	
6	Return R	R signal GND	
7	Return G	G signal GND	
8	Return B	B signal GND	
9	Reserved	NC (reserved for input)	
10	Digital Ground	Digital signal GND	
11	Reserved	NC (reserved for input)	
12	Reserved	NC (reserved for input)	
13	H. SYNC	Horizontal synchronous signal input	
14	V. SYNC	Vertical synchronous signal input	
15	Reserved	NC (reserved for input)	

Connector : Mini Dsub 15 pin BIOS  
Connector set screw : Inch type (4-40)  
Cable : Digital Electronic Corporation RGB cable  
(FP61V-IV00-0) (conforms to VGA standards)

## 2-3-2 Serial Interface

<b>Serial Interface</b>	Baud rate :	9600 bps
	Data length :	8 bits
	Parity :	None
	Stop bit :	1

### Pin Assignments and Signal Names for Serial Interface Connector

Pin No.	Signal Name	Condition	Pin Location
1	CD	Carrier Detect (FP -> Host)	
2	RD	Receive Data (FP -> Host)	
3	SD	Send Data (FP <- Host)	
4	DTR	Data Terminal Ready (FP <- Host)	
5	GND	Ground	
6	DSR	Data Set Ready (FP -> Host)	
7	RS	Request to Send (FP <- Host)	
8	CS	Clear to Send (FP -> Host)	
9	NC	No connection	

Connector : Dsub 9 pin female

Connector set screw : Inch type (4-40)

Cable : Digital Electronic Corporation SIO cable (FP61V-IS00-0)

#### Signal Names

Signal names used for the FP's serial interface are designed to match the pin order used on most PC serial interfaces, so that a straight cable can be used to connect the two. Therefore, connect each pin's signal to the same signal name on the PC connector.

For example, pin #2 'RD' should be connected to the 'RD' input terminal on the FP's connector.

Refer to section "2-4 Option Cable Pin Diagrams" for information about each signal's direction.

# Specifications

## 2-3-3 Keyboard Interface (KEYBOARD - Keyboard)

### Mini DIN 6-pin (Female)

(Common to front and side)

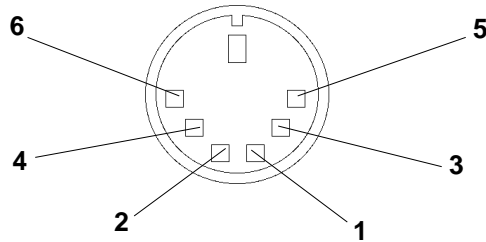

<Manufactured by Hoshi Electronics, Inc.:  
TCS7568-43-201 or equivalent>

Pin No.	Signal name
1	KEY DATA
2	NC
3	GND
4	+5V
5	KEY CLK
6	NC

Possible keyboards: FKB1424-001 (compact type) manufactured by Fujitsu, Inc.  
FKB4874-101 manufactured by Fujitsu, Inc.

## 2-3-4 Mouse Interface (MOUSE - Mouse)

### Mini DIN 6-pin (Female)

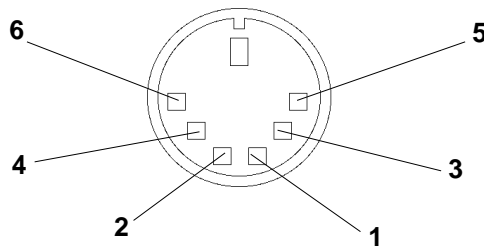

<Manufactured by Hoshi Electronics, Inc.:  
TCS7568-43-201 or equivalent>

Pin No.	Signal name
1	MOUSE DATA
2	NC
3	GND
4	+5V
5	MOUSE CLK
6	NC

Suggested Mouse: Microsoft (Corp.)'s Microsoft mouse (PS/2 type)

## 2-3-5 PC Interface (MOUSE-PC/KEYBOARD-PC)

### Mini DIN 4-pin (Female)

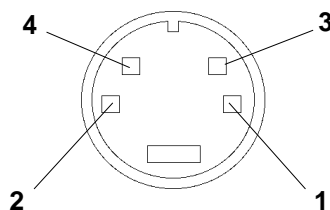

Pin No.	Signal name
1	GND
2	+ 5V
3	CLK
4	DATA

<Connector Maker: JST, JST/MD-S6100 or equivalent>

## 2-4 Option Cable Pin Diagrams

### RGB Interface Cable Pin (Optional cable: VGA specification) Assignments

FP Connector			RGB cable		PC Connector				
1	Analog R	Input	1	RED IN	RED VIDEO	1	Output	RED VIDEO	1
2	Analog G	Input	2	GRN IN	GRN VIDEO	2	Output	GRN VIDEO	2
3	Analog B	Input	3	BLU IN	BLU VIDEO	3	Output	BLU VIDEO	3
4	Reserved	-	4	NC	NC	4	-	NC	4
5	Digital ground	-	5	GND	GROUND	5	-	GROUND	5
6	Return R	-	6	RED	GROUND RED	6	-	GROUND RED	6
7	Return G	-	7	GRN	GROUND GRN	7	-	GROUND GRN	7
8	Return B	-	8	GND	GROUND BLU	8	-	GROUND BLU	8
9	Reserved	-	8	BLU	NC	9	-	NC	9
10	Digital ground	-	9	GND	GROUND	10	-	GROUND	10
11	Reserved	-	10	NC	MONITOR	11	-	MONITOR	11
12	Reserved	-	11	GND	SENSE(COLOR)	12	-	SENSE(COLOR)	12
13	H.SYNC	Input	12	NC	MONITOR	13	-	MONITOR	13
14	V.SYNC	Input	13	HSYN	SENSE(MONO)	14	-	SENSE(MONO)	14
15	Reserved	-	14	VSYN	HSYN	15	Output	HSYN	15
FG	FG	-	15	NC	VSYN	14	Output	VSYN	14
			FG	FG	NC	15	-	NC	15
					FG	FG			

Signal names for the FP's RGB interface are designed to match the same pin order as the RGB interface on standard PCs. Since this cable is designed to use the same pin numbers for the FP and the PC, it can be connected in either direction. Since the PC connector's pitch is designated in "inch" units, the interface cable and the FP connector's pitch are also designated in "inch" units (4-40).

## Specifications

### Pin Connections for the SIO Interface Cable (Optional cable: PC/AT specification)

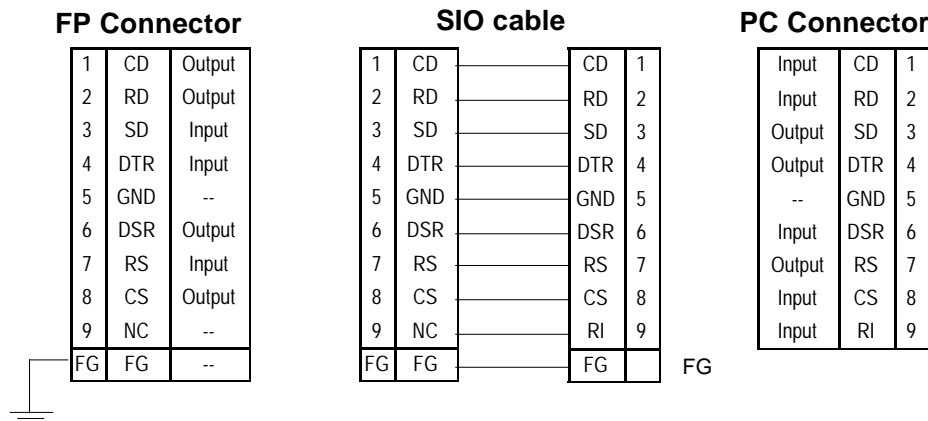

Signal names for the FP's SIO interface are designed to match the same pin order as the SIO interface on standard PCs. As a result, it can be connected in either direction. Since the PC connector's pitch is designated in "inch" units, the interface cable and the FP connector's pitch are also designated in "inch" (4-40) units.

### Mouse/Keyboard cable pin numbers

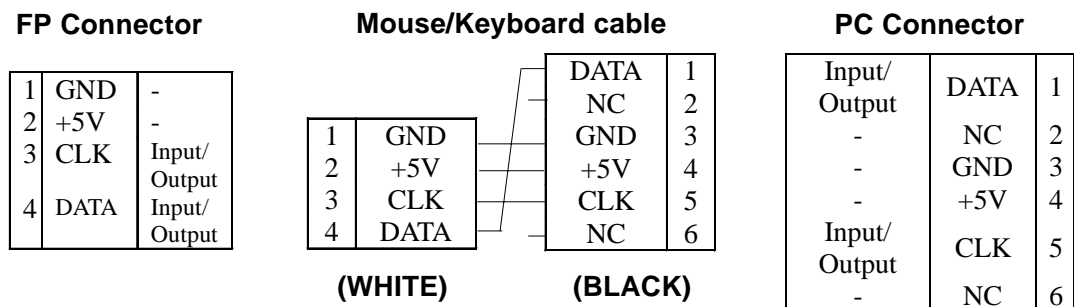

The signal names of the FP unit interface and the mouse/keyboard cable (FP-CK01) conform to those of the personal computer interface. To prevent accidents and connector damage, please be aware that the ends of this connector are different. Connect the 4 pin (white) connector to the FP, and the 6 pin (black) connector to the PC.

### Front View

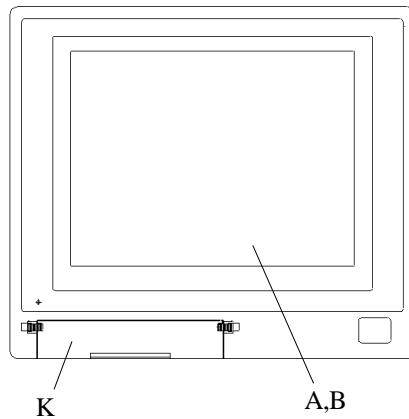

**A: TFT type color LCD**

The FP units' output display. Data from the host are displayed.

**B: Touch panel**

Used to switch screens and write data into the host.

**C: Power input terminal block**

Used to connect the power supply cable.

**D: Setup switches (DIP switches)**

Used to set the FP's operation mode.

**E: Analog RGB I/F connector**

Analog RGB interface connector

**F: RS-232C connector**

RS-232C (serial) interface connector used to send touch panel data between the FP and host, and to send commands to the FP.

**G: MOUSE/Mouse connector**

Accepts standard mouse input.

**H: MOUSE/PC connector**

Used to output mouse data from the FP (to a PC). Cable from here connects to any PS/2 compatible mouse input connector.

**I: KEYBOARD/Keyboard connector**

Used to connect the PS/2 compatible keyboard.

**J: KEYBOARD/PC connector**

Used for FP keyboard data output. Connects to the PS/2 compatible keyboard input connector.

**K: Front maintenance cover**

Protects the FP's RESET switch and keyboard connector.

### Rear View

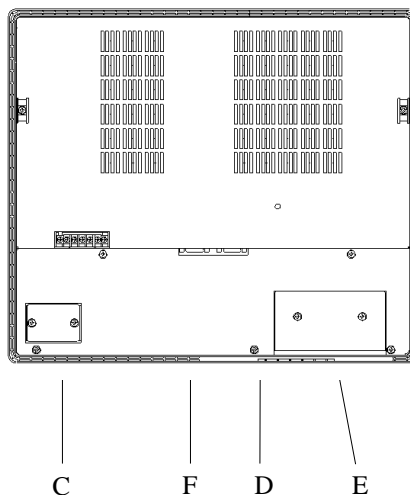

### Bottom View

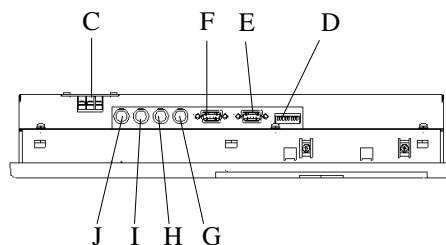

**Be sure that all cables are connected correctly and that the FP is turned OFF before any cables are disconnected, since either of these can cause the FP to malfunction.**



# Specifications

<b>2-6</b>	<b>Flat Panel (FP) Dimensions</b>
------------	-----------------------------------

## 2-6-1 FP-770T External Dimensions

Unit: mm

### Top View

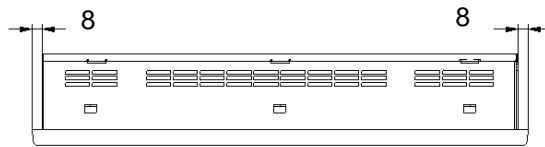

### Front View

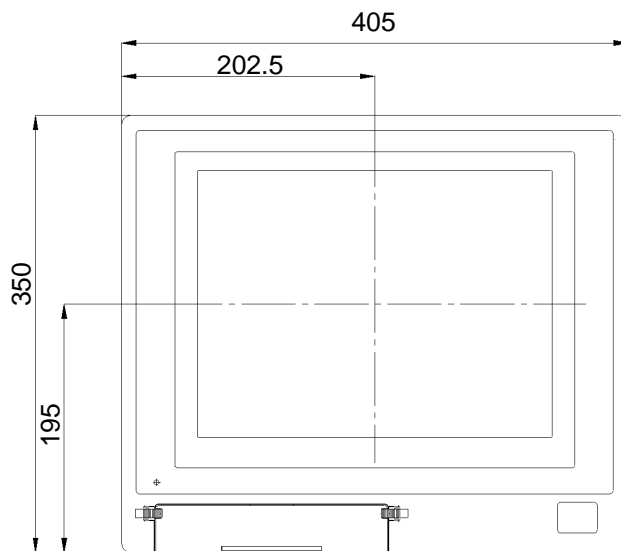

### Side View

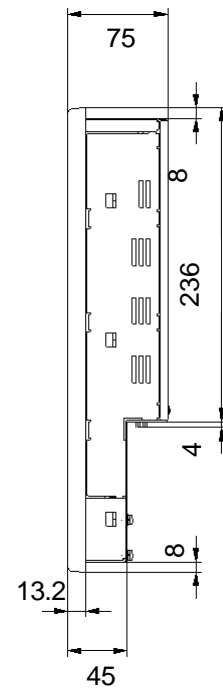

### Rear View

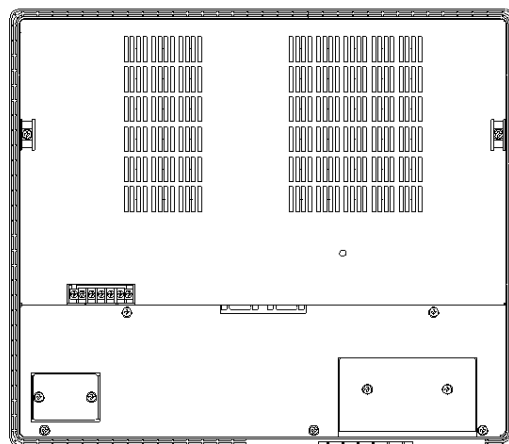

2-6-2 Installation Brackets

Unit: mm

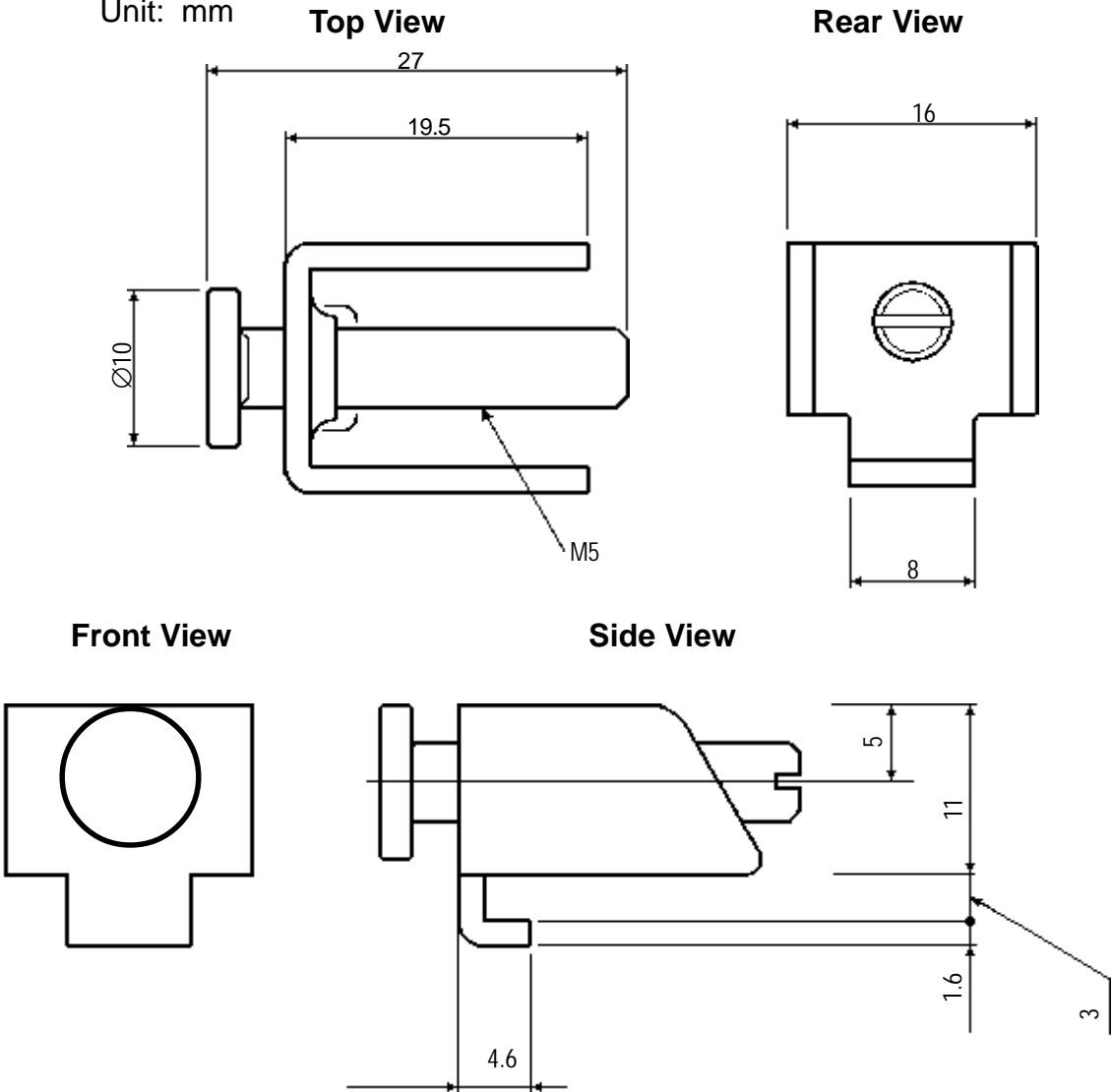

2-6-3 FP Installation Hole Dimensions

Unit: mm

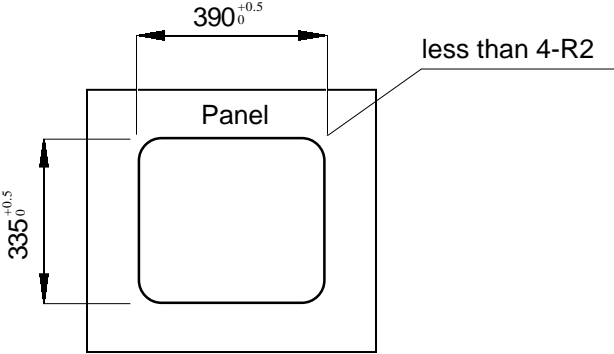

*If the FP's mounting panel is not sufficiently thick or strong, the specified level of moisture-resistance may not be possible.*

## Chapter 3 Installation and Wiring

1. Installation
2. Wiring
3. Setup of Operation Mode and Positioning of Display

### 3-1 Installation

#### 3-1-1 Installation Procedures

Install the FP according to the following procedures.



- **Before installing the FP, be sure the moisture-resistant gasket is securely attached.**

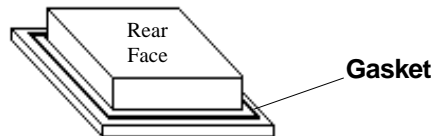

##### 1. Create an Installation Hole

Using these FP installation dimensions as a guide, create (cut) the correct sized installation opening. The FP's seal, installation brackets and screws are all required when installing the FP. .. **Reference** 2-6-3 FP Installation Hole Dimensions

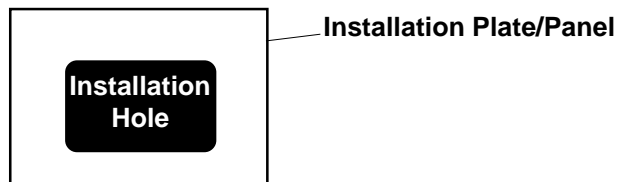

- It is important that the plate/panel surface is flat, clean, and without any jagged edges. If the panel is thin and may warp, attach a reinforcing plate to the panel.
- The Plate/Panel thickness should be between 1.6 and 10.0mm.

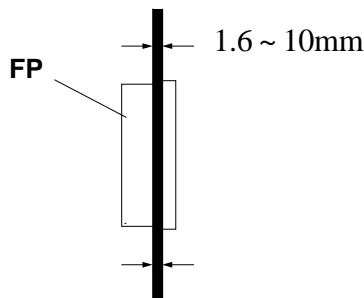

- **If the plate/panel used is too thin or weak, a satisfactory moisture-resistant seal may not be created.**

## Installation and Wiring



- For easier maintenance and operation, and improved ventilation, be sure the FP is installed at least 100 mm away from any adjacent structures or objects.

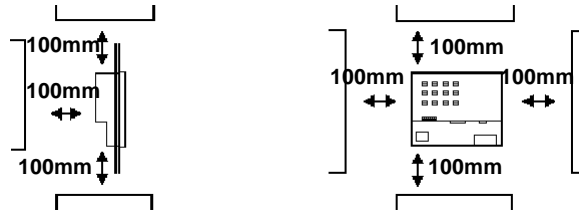

- The FP uses natural ventilation through its outer shell for cooling. When installing the unit horizontally or sideways (portrait style), use a fan or air conditioning unit to prevent overheating.

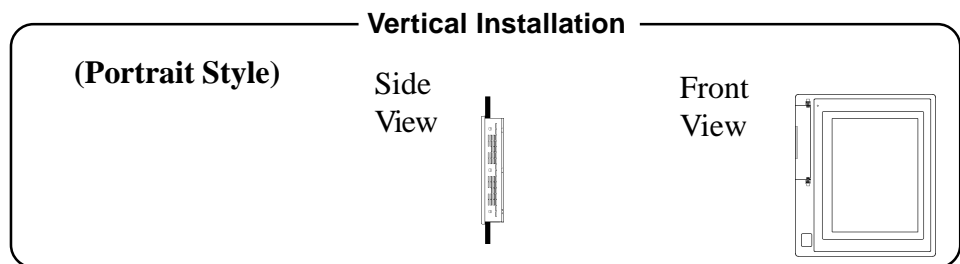
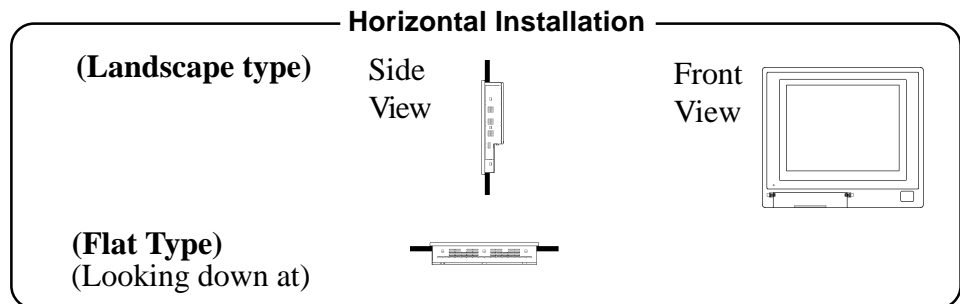

- Check that heat from surrounding equipment will not cause the FP to overheat.
- Be sure this unit is located as far away as possible from electromagnetic circuits, non-fuse type breakers, and other equipment that can cause arcing.
- When installing the FP in a panel with an angled face, the face should not incline either backwards or forwards more than 30°.

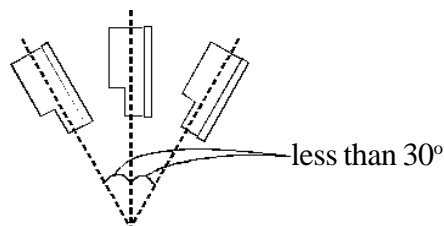

Insert the FP into the installation hole from the front of the panel.

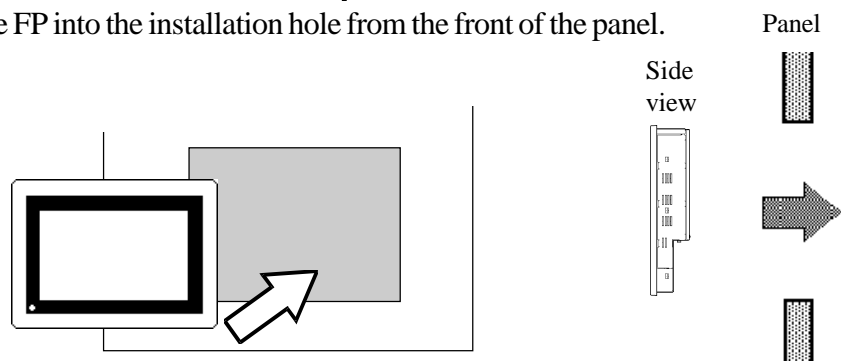

## Installation and Wiring

### 2. Secure the FP in place using the mounting brackets.

Insert the mounting bracket hooks into the slots provided on the top, bottom and sides of the FP (three slots on the top and bottom and three slots in the right and left sides, respectively).

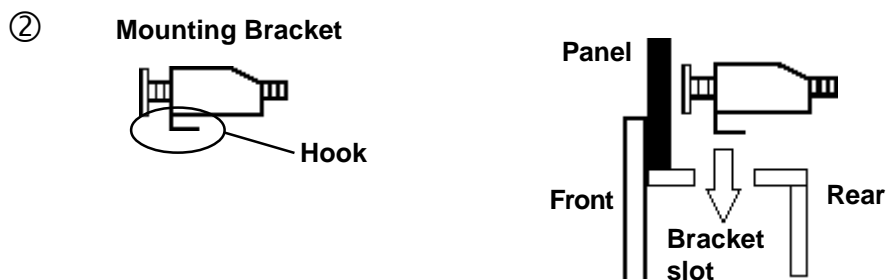
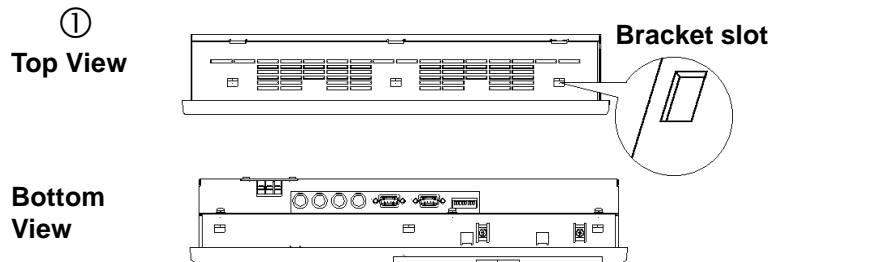

- ③ After inserting the hook into the slot, move the bracket backward. Then, use a screwdriver to tighten the screw and secure the FP in place.



Tighten the mounting bracket's screw with a screwdriver. To ensure the FP's front panel is sufficiently moisture-resistant, tighten the screw with no more than 0.5 to 0.6 N-m of torque.

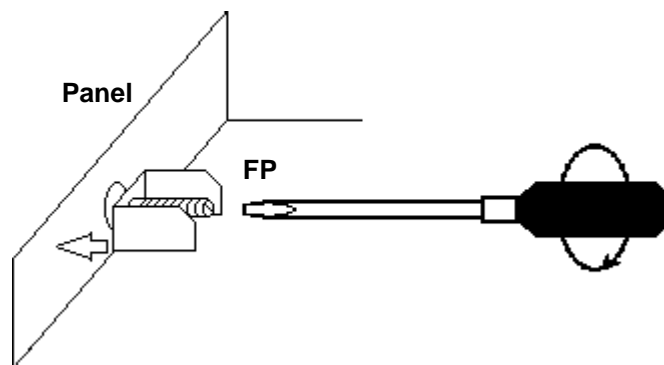

**Excessive torque may cause damage to the unit.**

## 3-2 Wiring

This section describes wiring installation precautions and the FP's power cable wiring procedure.

### 3-2-1 Power Cable Connection Precautions



- When connecting the power cable, be sure that power is not supplied to the FP due to the danger of electric shock.
- If a voltage exceeding the FP's specified power range is applied, both the FP and the power supply units will be damaged.
- Since the FP has no power switch, set up a separate circuit breaker.



- When the frame ground (FG) terminal is not connected, the FP is easily affected by noise interference. Be sure to ground the unit.



- Use thick wire (2 mm<sup>2</sup> max.) for the FP's power cable. Be sure that the cable is twisted near the ring terminals.
- Use ring terminals with the following dimensions:

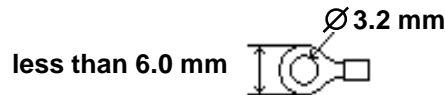

- To prevent the power terminals from being short-circuited due to a loose screw, use ring terminals with insulating sleeves.

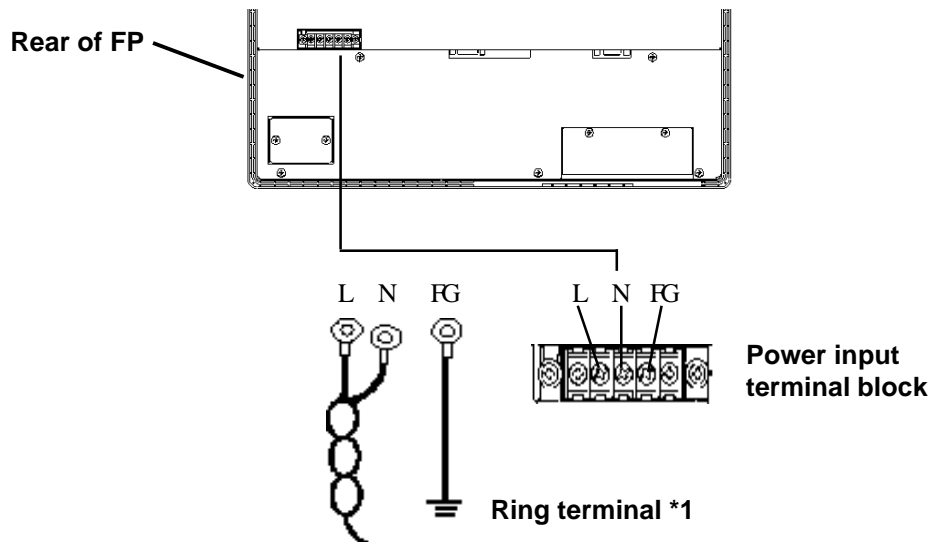

- \*1 L = Live line for AC input  
 N = Neutral line for AC input  
 FG = Ground terminal to be connected to the FP housing  
 Recommended ring terminal: V2-MS3 or equivalent  
 (Manufactured by JST Co.)

## Installation and Wiring

### 3-2-2 FP Power Cable Connection Procedure

---

- 1) Connect the FP's power cable to the main power supply.
- 2) Check to make sure the FP's power cord is disconnected from the main power supply.
- 3) Remove the terminal block's transparent cover.
- 4) Remove the screws from the 3 middle terminals, align the ring terminals and re-attach the screws. (Check that each wire is securely connected)
- 5) Replace the terminal block's transparent plastic cover.

 **Note:** Use no more than 0.5~0.6N•m of torque to tighten the screws.

## 3-2-3 FP Power Supply Connection Procedures

Please pay special attention to the following points when connecting the power cable to the FP-770T's Terminal Block.

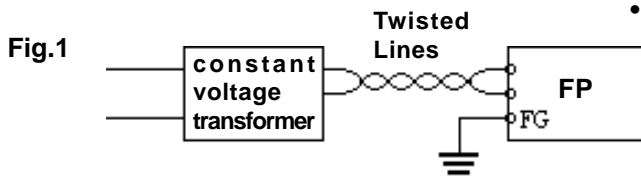

- If the voltage supplied exceeds the FP's designated range, connect a voltage transformer.

**Reference** Chapter 2, "Specifications", for the allowable voltage range.

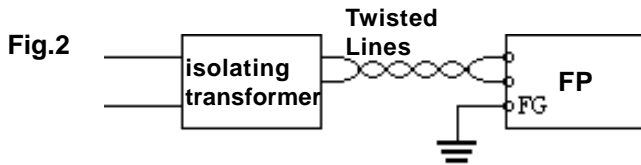

Between the line and ground, select a power supply that is low in noise. If there is an excessive amount of noise, connect a noise reducing transformer.

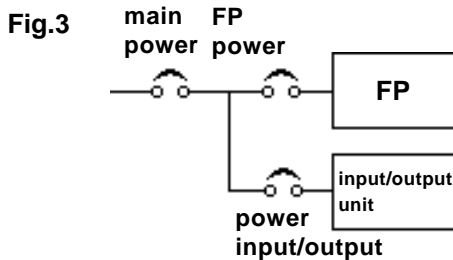

**Note:** Use Voltage and Noise Reducing transformers with capacities in excess of 100VA.

- When supplying power to the FP, separate the power input/output and operation signal lines as shown in figure 3.

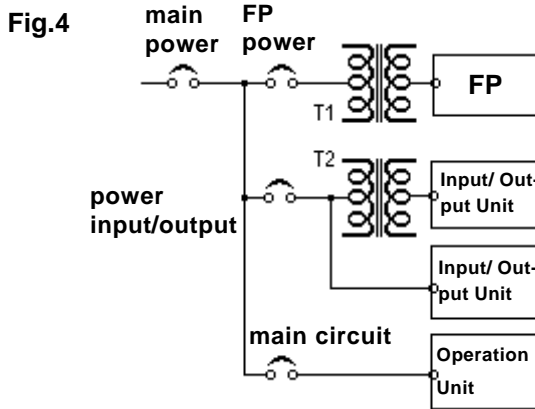

- To increase the FP's noise resistance, twist the power cable before connecting it to the FP.

- The power cable must not be bundled or kept close to the main circuit lines (high voltage, high current), or input/output signal lines.

- Connect a surge absorber, as shown in the diagram, to deal with power surges.

- To prevent noise, make the power cable as short as possible.

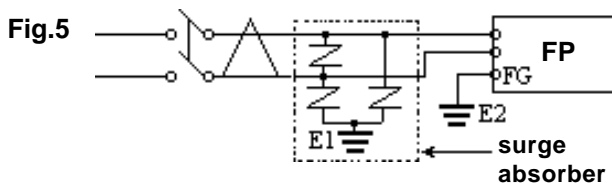

**Note:** Be sure the surge absorber (E1) is grounded separately from the FP (E2).

- Select a surge absorber that has a maximum circuit voltage greater than the power supply's peak voltage.



# Installation and Wiring

## 3-2-4 FP Grounding Cautions

---

- (a) **Exclusive grounding (BEST)** • Connect the FP's FG terminal to an exclusive ground. [Grounding resistance of under 100Ω.]

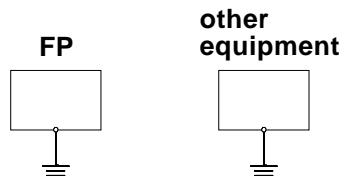

- (b) **Common grounding (OK)** • If exclusive grounding is not possible, use a common grounding point.

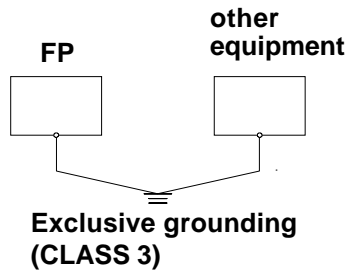

- The grounding wire should have a cross section larger than 2mm<sup>2</sup>. Make the connection point as close to the FP as possible, and make the wire as short as possible. When using a long grounding wire, use a thicker wire placed in a duct.

- (c) **Common grounding (BAD)**

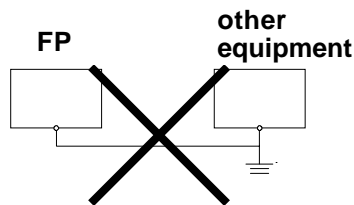

- If the FP does not function properly when grounded this way, disconnect the ground wire from the FP's FG terminal.

## 3-2-5 FP Input/Output Signal Line Cautions

---

- Input and output signal lines must be separated from power cables.
- If this is not possible, use a shielded cable and connect the shield to the FP chassis.

## 3-3 Setup of Operation Mode and Positioning of Display

### 3-3-1 Operation Mode Setup and Adjustment

The setup switches (dip-switches) are located in the rear of the FP.

FP-770T (rear view)

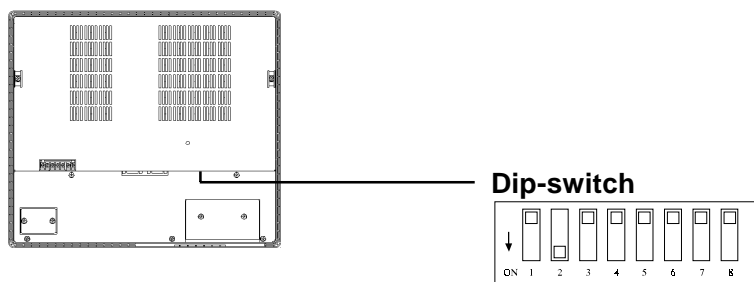

Prior to shipment, the FP's DIP switches (SW1) have been set as shown above. These 8 bit DIP switches (SW1) control the items listed below:

No.	Function	OFF	ON
1	Touch Panel Output Method	RS-232C output	PS/2 mouse compatible output
2	Backlight Setting 1	See table on next page	
3	Backlight Setting 2		
4	Backlight Setting 3		
5	Calibration	Normal mode	Calibration mode
6	Click Sound	Click sound OFF	Click sound ON
7	Reserved	Set this switch to OFF	
8	Reserved	Set this switch to OFF	

#### • SW1-1

Designates the touch panel data output method.

**OFF:** SIO (RS-232C) output

When the FP is connected to the host (PLC), emulation software (e.g TT-WIN) is required to perform touch operation.

**ON:** PS/2 mouse compatible output

Touch panel data is converted to PS/2 mouse-compatible format, and output through the mouse output port.

When the FP is connected to the Host's PS/2 mouse port, you can perform touch operation without using special emulation software or a special driver.



• **The use of PS/2 mouse compatible output may be limited, depending on the OS being used.**

**Reference** 4-2 Touch Panel Data Input

## Installation and Wiring

### • SW1-2, SW1-3, and SW1-4

These switches are used in various combinations to control the backlight brightness used at start-up, automatic dimming, and automatic switch-off of the backlight after 2.5 and 5 minute intervals of no SIO communication or touch panel operation.

Once SIO communication or touch operation is performed, the backlight is returned to its initial condition.

SW1-2	SW1-3	SW1-4	Brightness at start-up	After 2.5 minutes without SIO communication or touch operation	After 5 minutes without SIO communication or touch operation
OFF	OFF	OFF	Low brightness		
ON	OFF	OFF	High brightness		
OFF	ON	OFF	Low brightness		OFF
ON	ON	OFF	High brightness		OFF
OFF	OFF	ON	Disabled		
ON	OFF	ON	High brightness		Low brightness
OFF	ON	ON	Disabled		
ON	ON	ON	High brightness	Low brightness	OFF



• **When the FP receives a display-related SIO command from the host, the backlight's automatic brightness reduction/power-off functions are canceled.**

• **To perform simultaneous keyboard and touch panel operation, do not enable the backlight's automatic dimming/switch-off functions, since during keyboard operation these functions cannot be activated.**

### • SW1-5

This switch is used to enable recalibration of the PS/2 mouse compatible output mode (when the SW 1-1 is ON). This feature allows the User to correct any displacement that way have developed between the screen's displayed position and the actual touch position.

Use the following steps to recalibrate the screen:

- 1) Set the SW1-5 switch to ON to start the recalibration mode. (The FP's buzzer sounds, and stops touch panel data output)
- 2) Press the upper right corner of the display.
- 3) Press the lower left corner of the display.



• **In calibration mode, removing your finger from the screen will enable that position and cause a short beep to sound.**

• **When the input is incorrect (due to the procedures being performed out of order, etc.) a warning beep will sound and the unit will wait for the correct input.**

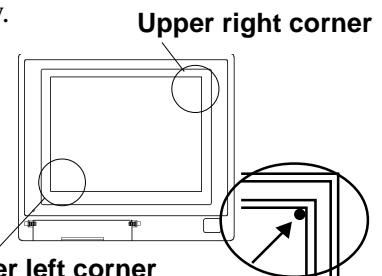

- 4) Set the SW1-5 switch to OFF to quit the recalibration mode. (The FP stores the calibration data, sounds the buzzer, and re-starts touch panel data output)



• **The buzzer will sound continuously while the calibration data is being saved. While the buzzer is sounding, do not reset the unit or turn it OFF.**

• **SW1-6**

This switch is used to set the FP touch panel's click sound.  
When set to ON, every time the touch panel is touched in the PS/2 mouse compatible output mode (when SW 1-1 is ON), a click will sound.

• **SW1-7**

This switch is reserved for future system expansion.  
Set this switch to OFF.

• **SW1-8**

This switch is reserved for future system expansion.  
Set this switch to OFF.

**Using the touch panel to adjust display features**

Press both the RESET switch located in the front maintenance panel and the upper left corner of the FP display to start display adjustment mode.  
In display adjustment mode, specified areas on the touch panel are used as setting switches (see the figure below). These switches can be used to adjust the dot clock phase/frequency and display position. (The following figure is a schematic view only for explanation. An actual screen will show host output data)

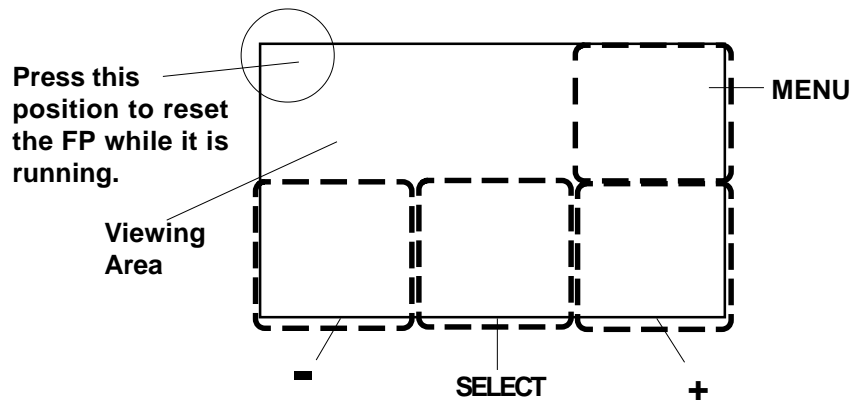

**MENU**

This area displays one of the FP's two adjustment menus. Every time you press this switch, the display toggles between Adjustment Menu 1 and 2.

**Adjustment Menu 1**

- PHASE
- CLOCK
- H-POS
- V-POS
- SIZE (NORM EXP)
- MODE(VESAMAC)

**Adjustment Menu 2**

- R-CONT
- G-CONT
- B-CONT
- CONT
- BRIGHT

- PHASE Adjust the dot clock phase.
- CLOCK Adjust the dot clock frequency.
- H-POS Adjust the horizontal position.
- V-POS Adjust the vertical position.

## Installation and Wiring

SIZE	Used to select the display size. Either center display mode or full screen display mode can be selected. (In the XGA display mode, selecting “NORM” automatically selects the full screen display mode.)
	NORM: Center display      EXP: Full screen display
MODE	Always select “VESA”.
R-CONT	Used to adjust red.
G-CONT	Used to adjust green.
B-CONT	Used to adjust blue.
CONT	Used to adjust the contrast.
BRIGHT	Used to adjust the brightness.
SELECT	Used to select the adjustment items. Press this switch to select an item.(Item changes to reverse video) Pressing again deselects the item.
+	Used to increment the value of the selected item. When the value reaches the upper limit of the setting range, any further switch input is ignored. Pressing this switch in the SIZE (size switching) mode sets the display size to “EXP” (Expanded display).
-	Used to decrement the value of the selected item. When the value reaches the lower limit of the setting range, any further switch input is ignored. Pressing this switch in the SIZE (size switching) mode sets the display size to “NORM” (Normal display).

To perform display adjustments, follow the procedures given below:

- 1) Press the RESET switch located in the front maintenance panel while touching the upper left corner of the FP display to start the display adjustment mode.
- 2) Normally, display adjustment mode is in standby. Press the [MENU] switch to activate the setting switches. Adjustment Menu 1 is then displayed.
- 3) Use the [SELECT] switch to select a desired item.
- 4) Use the [UP] or [DOWN] switches to change the value of the selected item.
- 5) Press the upper left corner of the FP display again to exit the display adjustment mode.



- To adjust the FP's image quality, press the [PHASE] and [CLOCK] switches alternately until the optimal image appears.



## Chapter 4

# Touch Panel Commands

1. Command List
2. Touch Panel Data Input
3. Boot-up Initialization

### 4-1 Command List

This section describes the serial commands available with the FP (command transmission from the host (PLC) to the touch panel (FP)).

#### <Serial Command List>

Code	Function
65h	Turns on the backlight at high brightness.
66h	Turns on the backlight at low brightness.
67h	Turns off the backlight. (Automatic reset)
68h	Turns off the backlight. (Command reset)
69h	Turns on the click sound.
6Ah	Turns off the click sound.
71h	Turns on the buzzer.
72h	Turns off the buzzer.
73h	Turns on calibration mode.
74h	Turns off calibration mode.
75h	Turns on touch panel data output.
76h	Turns off touch panel data output.



**Important** • All codes other than those shown here are reserved. These commands should never be issued when using the FP.



**Note:** • All data and command codes are expressed in hexadecimal numbers. (Example: 65h = 65HEX)

Backlight ON (High brightness) 65h

Turns on the backlight at high brightness.

Backlight ON (Low brightness) 66h

Turns on the backlight at low brightness.

## Touch Panel Commands

**Backlight OFF (Automatic reset)** 67h

Turns off the backlight. When either SIO communication or touch operation is performed, the backlight is turned on.

 **Note:** • The backlight condition after reset depends on the DIP switch settings (SW1-2, SW1-3, and SW1-4).

**Backlight OFF (Command reset)** 68h

Turns off the backlight. After a different serial command (e.g. 65h, 66h) is received, the backlight is turned on.

**Click sound ON** 69h

Every time you touch the display panel a click will sound.

**Click sound OFF** 6Ah

Turns off the click sound.

**Buzzer ON** 71h

Turns on the buzzer output

**Buzzer OFF** 72h

Turns off the buzzer output.

 **Note:** • Priority is given to buzzer output over the click sound. Thus, when both the buzzer output and click sound are set to ON, the buzzer output is activated.

Buzzer	Click	Status
ON	ON	Buzzer ON
ON	OFF	Buzzer ON
OFF	ON	Click sound ON
OFF	OFF	Buzzer and click sound OFF

**Calibration mode ON** 73h

Starts touch panel calibration mode. (Same function as when SW1-5 is ON.)

**Calibration mode OFF** 74h

Ends touch panel calibration mode. (Same function as when SW1-5 is OFF.)

**Touch data ON** 75h

Enables touch panel data output.

**Touch data OFF** 76h

Disables touch panel data output.



## Touch Panel Commands

### 4-2 Touch Panel Data Input

Two connection methods are available for sending touch panel data from the FP to the host: an RS-232C connection and a PS/2 mouse compatible connection. This section includes instructions for creating both.

#### RS-232C connection (When SW1-1 is OFF)

When the touch panel is used during the RS-232C (SIO) connection mode, coordinate output data sent from the FP to the host is not exactly equal to the coordinates used on the display device. Therefore, an I/F program is necessary to convert the coordinates on the touch panel into those used on the display device. It is also necessary to calibrate individual differences, depending on the touch panel used.

The mouse emulation software listed below can automatically convert the coordinates with simple initial settings.

OS	I/F program	Calibration	Application	SW1-1 setting
Windows® 95	PL-ME000*1	Included in I/F program	i.e. FIX-32*1	OFF (RS-232C output)
WindowsNT™4.0	TT-WIN/NT*1	Included in I/F program	i.e. FIX-32*1	
Windows® 3.1	TT-WIN*1	Included in I/F program	i.e. FIX-DMACS*1	
Other OS	Prepared by user		Depending on the specifications of the program	

A separate conversion program is required for a different user-prepared OS. To create a conversion program for a different OS, please observe the following instructions:

#### (1) Resolution

The FP has “1024” resolution in both the X and Y axes. The origin point (0,0) is in the upper right corner.

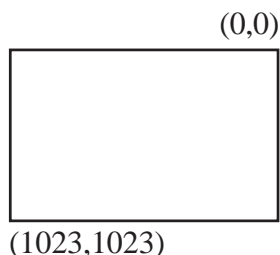

The display device however provides “1024 x 768” resolution with the origin point located in its upper left corner. Therefore, the FP's touch panel data must be converted to the actual display coordinates.

\*1 The following software programs are sold separately:

- PL-ME000: Mouse simulation software for Windows 95, manufactured by the Digital Electronics Corporation
- TT-WIN: PC/AT-compatible mouse simulation software for Windows 3.1, manufactured by GUNZE LIMITED
- TT-WIN/NT: PC/AT-compatible mouse simulation software for Windows NT, manufactured by GUNZE LIMITED
- FIX-DMACS: Personal computer instrumentation package software, manufactured by INTELLUSION
- FIX-32: Personal computer instrumentation package software, manufactured by INTELLUSION

# Touch Panel Commands

## (2) Data Format

All data is in 8-bit ASCII format, and is structured in the following 11 byte strings.

Header: 1 byte (T = touched; R = released)  
 X coordinate: 4 bytes (0000 ~ 1023)  
 Separator: 1 byte (,)  
 Y coordinate: 4 bytes (0000 ~ 1023)  
 Termination code: 1 byte (CR = 0Dh)

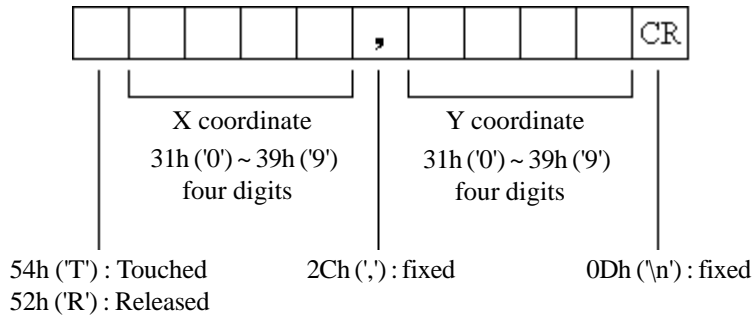

<Example> If the coordinate (X=23, Y=500) is touched.

T0023, 0500CR — touched  
 T0023, 0500CR — continuous output at the same location  
 T0024, 0500CR — moving the finger without releasing touch  
 T0024, 0499CR  
 ⋮  
 ⋮  
 T0022, 0501CR  
 T0023, 0500CR  
 R0023, 0500CR — when released, only 1 unit of data is sent

continuous data output unless finger is released

## (3) Sampling Rate

A maximum of 87 points per second.



- **The PL's touch panel provides a resolution of “1024” (10 bit). However, the resolution of the actual output data is only 20 to 990 (approx.). Therefore, the coordinates of all this pixels on the horizontal axis cannot be detected. According to this calculation, the FP's output data includes coordinates that cannot be displayed, since the touch panel is larger than the display device.**

## (4) Cable Connection

Connect the RS-232C connector provided at the rear of the FP to the host's serial interface through the optional SIO cable.

### **Reference** Chapter 1 Introduction

Connect the host (PLC) data cable to the FP's rear mounted RS-232C connector. (Digital's optional SIO cable is recommended)

## Touch Panel Commands

### Connecting a PS/2 mouse (When SW1-1 switch is ON)

When the FP's PS/2 mouse connection mode is selected and the User's OS supports the PS/2 mouse, touch panel data is converted to PS/2 mouse data, and output through the MOUSE/PC connector. In this case, the I/F program that converts the coordinates output from the FP to the host (PLC) into the display device coordinates is not necessary.

#### (1) Setting up the mouse according to the current OS

Turn the FP and host (PLC)'s power on, and set up your OS's mouse and driver settings so that the PS/2 mouse can be used.



- For information about the mouse's setup procedure, refer to your OS maker's Operation manual.

#### (2) Connecting the data cable

Connect the optional mouse/keyboard cable to the MOUSE/PC connector provided at the rear of the FP and to the host (PLC)'s mouse connector port.

**Reference** Chapter 1 Introduction

#### (3) Connecting the mouse

The FP's touch panel can be used together with a mouse. Connect the mouse to the MOUSE/Mouse connector at the rear of the FP.



- After connecting the mouse, re-start the FP's OS.
- When Windows 95 or Windows NT is used, set the "Control panel - Mouse - Operation" feature to the slowest pointer speed and hide the pointer trace.
- To use OS/2, set the SW1-7 switch to ON.

**Reference** 3-3 Operation Mode Setup and Display Positioning



**Important**

- Do not connect this cable when the power to the FP and the host (PLC) are both ON.
- When a mouse is connected to the FP, it may not operate normally, depending on the combination of host (PLC) and mouse used, as well as the cable length.
- The mouse connection can be used for all equipment conforming to the PS/2 mouse standards. However, Digital cannot guarantee the FP will operate normally for all types of host and mouse combinations.
- This unit was developed using the Microsoft Mouse®. Microsoft's other mouse products, the "Itellimouse" and the "3 Button" mouse may not be used with this unit.

### Conditions and restrictions : Connecting a PS/2 mouse

The following conditions and restrictions apply when a PS/2 type mouse is used with the FP770T. Due to the effect of the combination of the type of PC, mouse and OS used, the FP-770T's touch panel may not operate correctly.

- (1) If the mouse used with the FP-770T is fully compliant with all PS/2 mouse standards there should be no usage problems, however, all commercially available PS/2 mouse products may not be fully compliant. This unit was developed using the Microsoft Mouse®. Microsoft's other mouse products, the "Itellimouse" and the "3 Button" mouse may not be used with this unit.
- (2) Please be sure that the mouse driver used is the "Microsoft PS/2 Port Mouse". In the Windows 95/NT "Control Panel" settings area, double-click on the Mouse icon to bring up the Mouse settings. First, click on the "Motion" tab, then drag the "Pointer Speed" setting bar to the far left for the fastest movement. Next, be sure the "Pointer Trail" "Show Pointer Trail" checkbox is not checked.
- (3) The "double-click" feature should be used only for maintenance or when developing applications, due to mouse operability problems that may occur.
- (4) The following PC's may have some coordinate positioning errors.
  - When the FP-770T is connected to a PC running the Windows NT OS, if the video controller used is the TRIO64 ViRGE S3, the touch position may be slightly skewed.

This phenomenon has been confirmed on the IBM-PC350 and the Fujitsu FMV-620T6C7 personal computers.
  - When using a laptop-type PC, or PC that utilizes both mouse and non-mouse pointing devices, or a PC that accepts "Hot Plug-in" type devices, the touch position may be slightly skewed.

This phenomenon has been confirmed on the Toshiba Dynabook 440CDT, and the SONY VAIO laptop PCs.
- (5) This unit is not compatible with OS/2 PCs and devices.

Since OS/2 PCs and devices use the function is not compatible, it cannot use in this unit.

When using the FP-770T in your system, be sure to test the unit carefully with all the connected devices.

## Touch Panel Commands

### 4-3 Boot-up Initialization

When the power is turned ON, the touch panel is initialized as follows.

- Clears its internal buffer.
- Initializes the serial communication mode.

<b>Baud rate</b>	9600bps
<b>Data length</b>	8 bits
<b>Parity</b>	None
<b>Stop bit</b>	1 bit

- Initializes the system default values.

<b>Function</b>	<b>Default setting</b>
Backlight	ON
Backlight condition	Depending on the SW1-2,3,4 settings
Click sound	Depending on the SW1-6 setting
Buzzer	OFF
Calibration mode	OFF
Touch panel data output	ON



# Chapter 5

## Troubleshooting

### 1. Troubleshooting

<b>5-1</b>	<b>Troubleshooting</b>
------------	------------------------

#### 5-1-1 Possible Device Problems

---

Two possible types of trouble are as follows.

- **No display**
  - No display appears after the unit is switched on.
  - The screen disappears during RUN mode.
  - The screen display is not normal.
- **Touch panel doesn't respond**

The touch panel does not react when pressed, or its reaction time is abnormally slow.

Troubleshooting procedures for these problems are described in the flowcharts on the following pages.



### Warning

- Because of the danger of an electric shock, be sure the power cable is not connected when wiring the unit.
- When changing the backlight, since there is a danger of an electric shock or burn, be sure to turn the FP off and wear gloves.



**Important**

***This section assumes that the FP is the cause of a problem, not the host (PLC). When the host is the problem, please refer to that device's manual.***

5-1-2 No Display

When the screen does not display when powering up, or if the screen turns OFF by itself, use the flowchart below to find an appropriate solution.

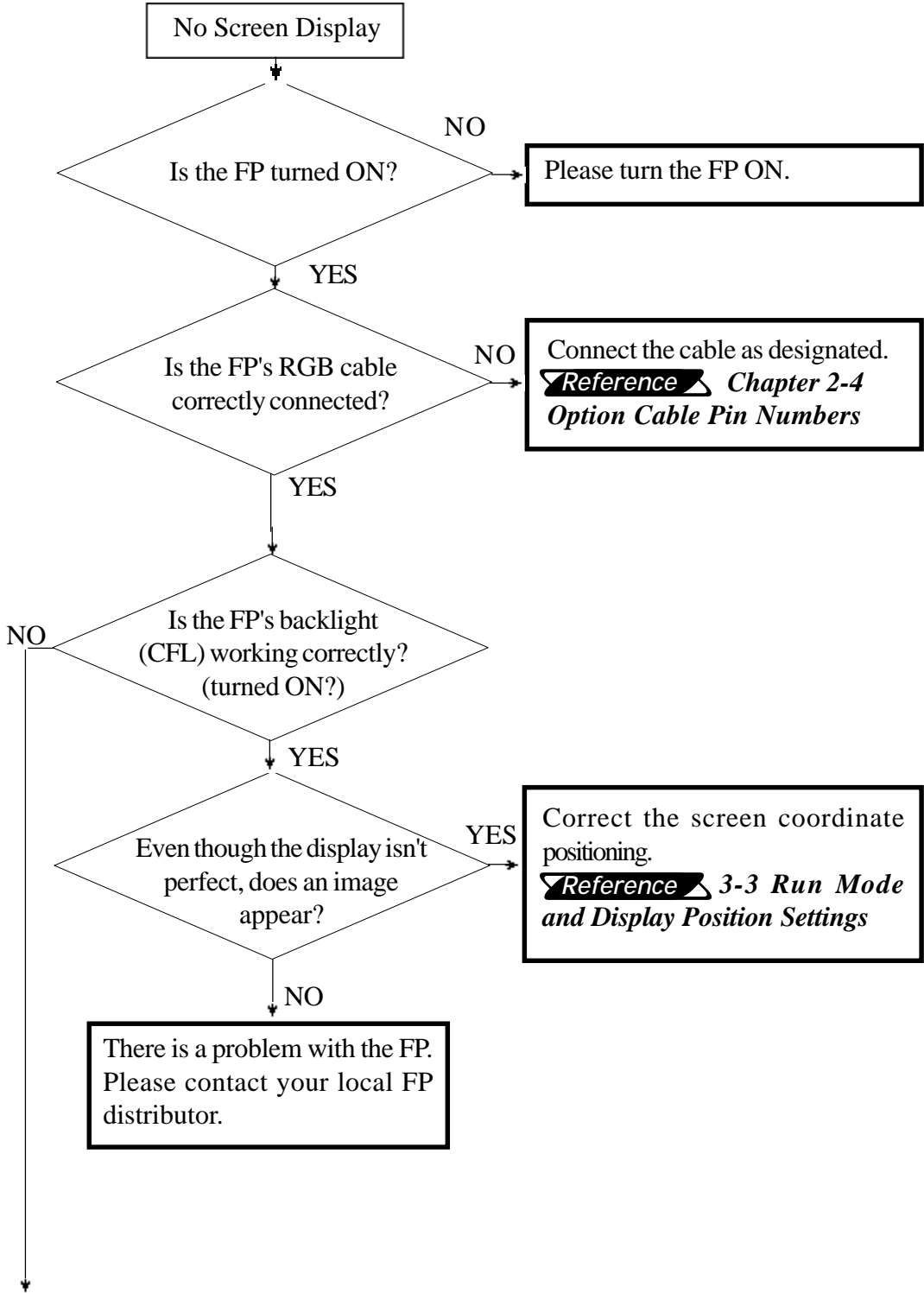



## Troubleshooting

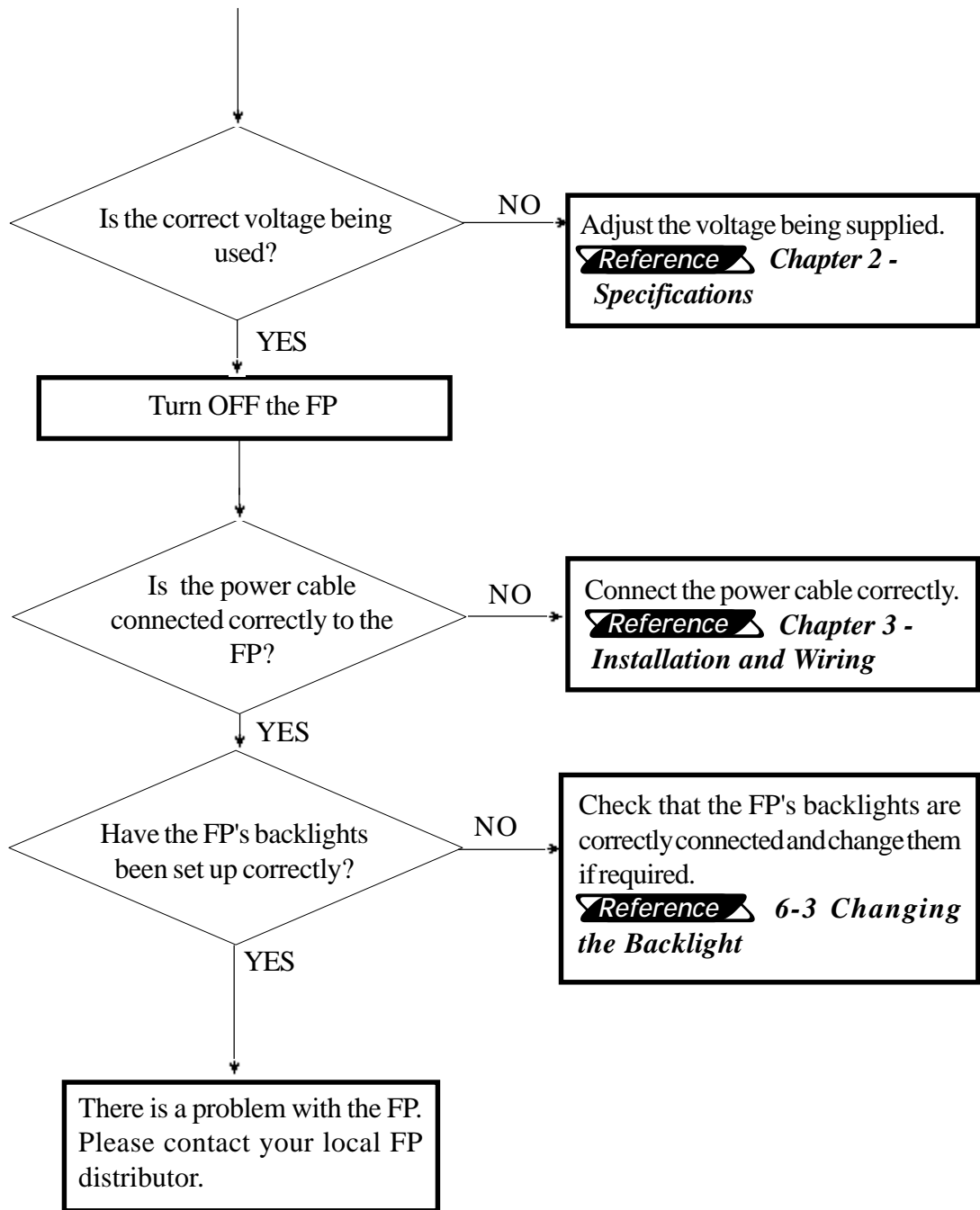

5-1-3 The Touch Panel Does Not Respond

When the touch panel does not react to your touch, use the flowchart below to find the origin of the problem and the appropriate solution.



- To use the SIO connection mode, a touch panel communication program is required.
- To use the mouse connection mode, it is necessary to set up the PS/2 mouse driver included in your OS.

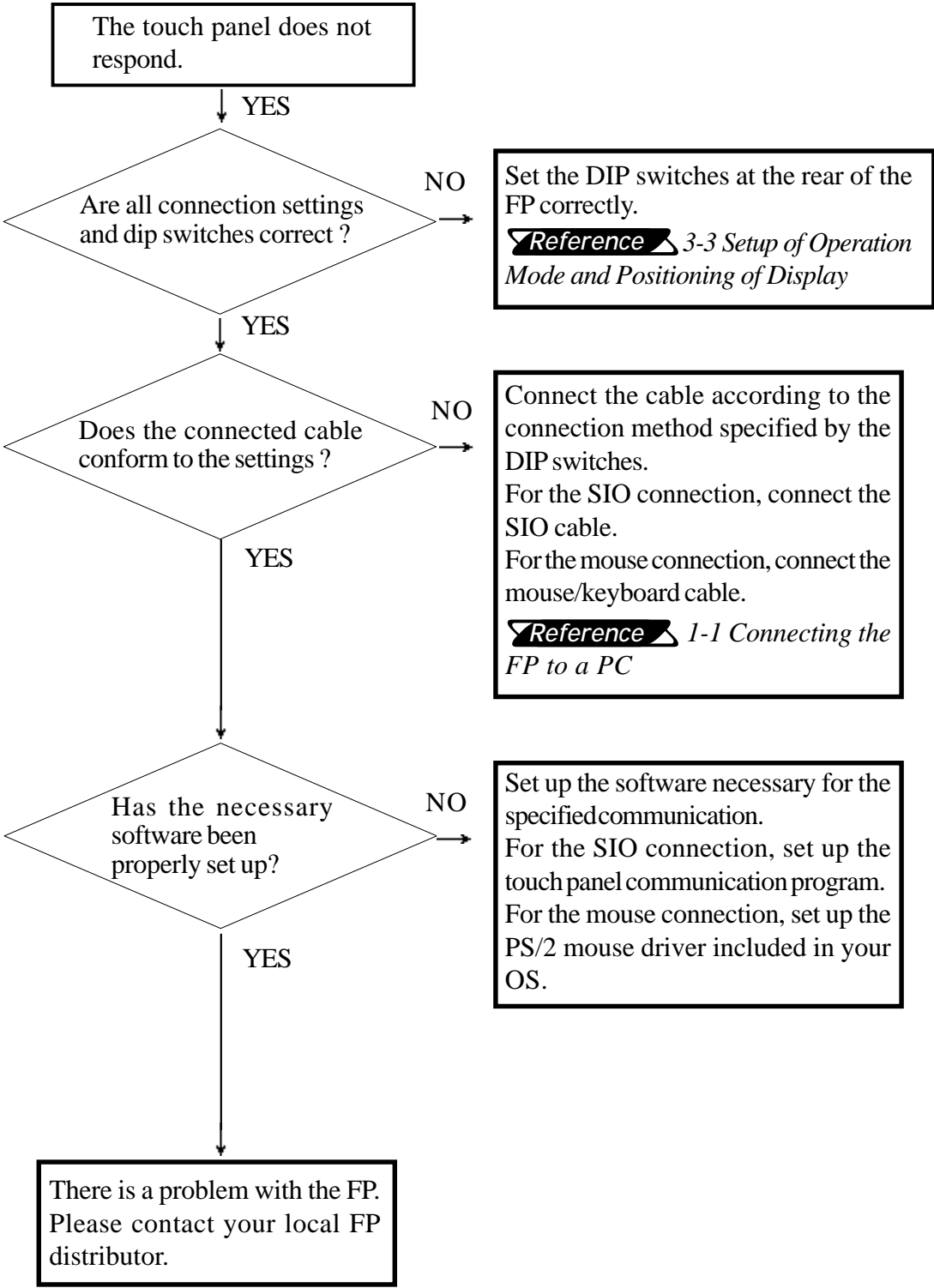

# Chapter 6

## Maintenance

1. Cleaning the FP's Display
2. Periodic Check-up
3. Changing the Backlight

This chapter describes the precautions and inspection procedures necessary to ensure satisfactory FP performance.

### 6-1 Cleaning the FP's Display



Neutral detergent

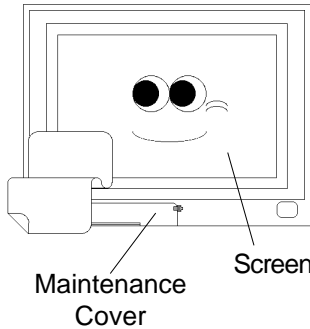

When the FP's display or case becomes dirty, use a neutral detergent applied to a damp soft cloth to clean the surface.



Paint thinner  
Organic solvent  
Acidic agents

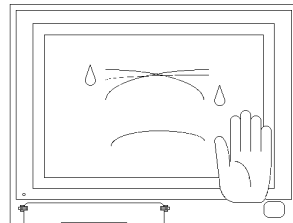

Do not use paint thinner, organic solvents, or highly-acidic agents to clean the unit.

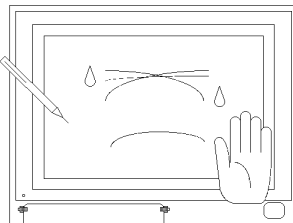

Do not press the touch panel display with sharp objects, such as a mechanical pencil; otherwise, the display may be damaged.

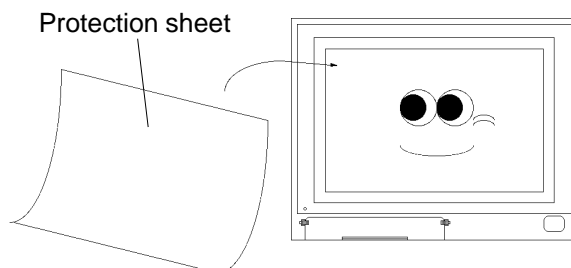

Attach the protection sheet when using the FP in a harsh environment.

### 6-2 Periodic Check-Up

To maintain your FP in its best condition, please check the unit periodically.

#### **Inspection Items:**

( When the FP is mounted into a cabinet, the conditions inside the cabinet are considered to be the environment )

#### **Surrounding Environment**

- Is the surrounding temperature within the allowable range? (0~40°C)
- Is the humidity within the specified range? (30~85% RH)
- Is the atmosphere free of corrosive gas?

#### **Electrical Specifications**

- Is the input voltage appropriate? (85 TO 265 VAC)
- Is the power supply voltage stable ?
- Is the power supply frequency correct (50/60 Hz) ?

#### **Attachments**

- Is the cable connected properly? Is it loose?
- Are the mounting brackets holding the unit securely?
- Are there many scratches, cuts or traces of dirt on the moisture-resistant seal?

### 6-3 Changing the Backlight



## Warning

- Whenever changing the backlight, be sure the power has been turned OFF.
- When the unit is hot, be sure to use gloves to prevent burns.
- When the unit is still ON, high voltage runs through the backlight area—*do not touch!*
- When the power has just been turned OFF, both the unit and backlight are still very hot.

Replace the backlight according to the procedure below. (The following explanation assumes that the FP has already been removed from the panel)

- ① Place the FP on a flat worktable with the front facing down.
- ② Loosen the screws at the seven positions shown on the rear of the FP, and remove the rear cover.

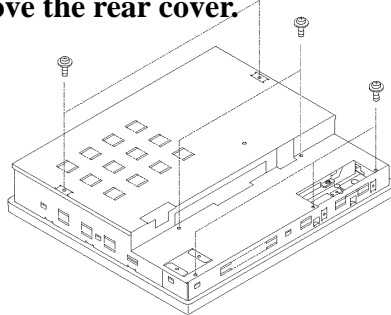

- ③ Loosen the screws at the three positions shown inside the FP, and remove the side bracket.

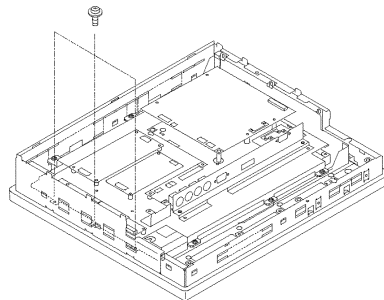

- ④ Remove the two connectors that connect the backlight to the inverter.

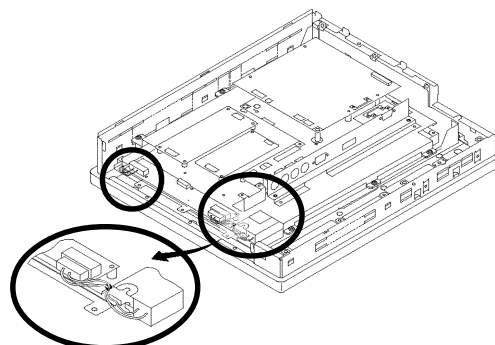

- ⑤ Lift up and hold either side of the inner unit.

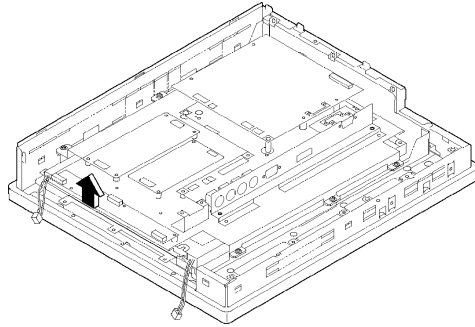

- ⑥ Gently, pull out each backlight horizontally from its holder.

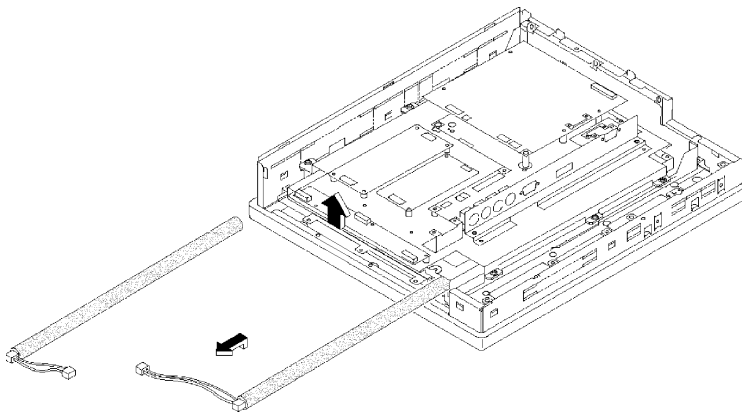

- ⑦ Insert each replacement backlight completely into its holder, and re-connect both connectors.
- ⑧ Attach the side bracket, and replace all three screws.
- ⑨ Mount the rear cover, and replace all the screws.



- *During replacement, be sure to protect the front surface of the FP's display so that it is not scratched or damaged.*
- *The FP has both an upper and a lower backlight bulb. Be sure to replace both at the same time.*

# Index

## Symbols

640 x 480 pixels  
Features viii

## A

Adjusting the Touch Panel's Display 3-9  
Afterimage iii  
Analog RGB  
    features viii  
Analog RGB Interface 2-3  
Analog RGB Interface Cable 1-1  
Angled Face  
    Installation 3-2  
Arcing 3-2  
ATPH.EXE 4-3

## B

Boot-up Initialization 4-2  
Brightness  
    conditions iii  
    variations iii  
Bundled Software  
    Communication Programs 5-1  
Buzzer 4-1  
Buzzer output 4-5

## C

Cable Diagrams 2-5  
CALIB.EXE 4-3  
Calibration mode 5-8  
Calibration program 4-3, 5-1  
Caution  
    explanation i  
Cleaning the Display  
    Maintenance 7-1  
Cleaning the display iii  
Click sound 4-1  
Color displacement 3-10  
Command List 4-1  
Common grounding 3-7  
Connecting the FP to a PC 1-1  
Contrast Volume 3-10

## D

Damages  
    responsibility iv  
Data Format  
    8-bit ASCII 4-4  
Default Contrast Volume Setting 3-10  
Dip switches 3-8  
Disassembling the unit ii  
Display coordinates 5-3  
Display mode vii  
Displayed color iii  
Dot Clock 3-9

## E

Easy Installation  
    Features viii  
Electrical shock ii  
    Wiring 3-5  
Electrical Specifications 2-1  
Environmental Specifications 2-1  
Excessively dusty or dirty environments iii  
Exclusive grounding 3-7

## F

FA (Factory Automation) viii  
Fire (Hazard) ii  
Flammable gas (environment) ii  
Flat Panel (FP) Dimensions 2-8  
Forced Reset 4-1  
FP Installation  
    Dimensions 2-9  
FP Parts  
    Names and functions 2-7  
Functional Specifications 2-1, 2-2

## G

General Specifications 2-1  
GLOBAL WINDOW SETUP  
    GLOBAL WINDOW 5-5  
Graphic Panel  
    Auxiliary Input/Output 2-7  
    GP-470 External Dimensions 2-8  
    Installation Brackets 2-9  
    Installation Dimensions 2-9  
    Names and Functions of parts 2-5, 2-7  
    Power Input Terminal Block 2-7  
    Serial Interface 2-7  
    Ventilation 3-2  
Ground wire  
    Wiring 3-5  
Grounding wire 3-7  
Guidelines ii

## **H**

- Header
  - Data Format 4-4
- High voltage ii

## **I**

- I/O cover
  - Contrast Adjustment 3-10
- Infinite wait
  - Touch Panel Input 5-5
- Insertion Slot 3-3
- Inspection Items
  - Maintenance 7-2
- Installation 3-1
- Installation brackets
  - Dimensions 2-9
  - Packaging ix
- INT 59H Function List 5-5
- Interface Specifications 2-3
- Internal buffer 4-2
- IP65F standard 2-1

## **L**

- Liquid Crystal Display (LCD) iii

## **M**

- Main circuit
  - Wiring 3-6
- Main Menu 4-2, 4-3
- Metallic dust ii
- Mouse simulation driver 4-3

## **N**

- Natural ventilation iii, 3-2
- No Screen Display
  - Troubleshooting 6-2
- Noise resistance
  - Wiring 3-6
- Non-Digital cable 2-3

## **O**

- OA (Office Automation) viii
- Operating Environment
  - Oil Resistance 2-1
- Operation Mode Setup 3-8
- Optional Equipment 1-2
- Overheating 3-2

## **P**

- Packaging
  - Contents ix
- PC Connectivity
  - Notes vii
- Periodic Check-Up
  - Maintenance 7-2
- Pin Assignments 2-3
- Possible Device Problems 6-1
- Power Cable Connection
  - Wiring 3-5
- Power Terminal
  - Wiring 3-5
- Power Terminal Block 3-5
  - Wiring 3-5
- Power Terminals 3-2
- Precautions: Grounding 3-7
- Precautions: Input/Output Signal Lines 3-7
- Precautions: Power Supply 3-6
- Printer Connection 3-1, 3-8
- Printer Interface 2-3
- Priority
  - Buzzer and Click sounds 4-6

## **R**

- Reserved
  - Commands 4-6
- RGB Interface Cable
  - Pin connections 2-5
- Rubber gasket 3-1

## **S**

- Safety Instructions ii
- Sampling Rate
  - Screen 4-4
- Screen display iii
- Screen display origin 4-3
- Screen flicker 3-10
- Serial communication mode 4-2
- Serial Interface 2-4
- Shielded cable
  - Wiring 3-7
- Sideways Installation 3-2
- Signal Names 2-3, 2-4
- SIO Interface Cable 1-1
- SIO transmission 3-9
- Specifications
  - Electrical 2-1
  - Environmental 2-1
  - Interface 2-3
  - Structural 2-3



Structural Specifications 2-3  
Surge Absorber 3-7  
Surge absorber 3-7  
Switch SW1-4 2-3  
Symbols i  
System default values  
    Initialization 4-2  
SYSTEM ENVIRONMENT SETUP 5-3  
    SYSTEM SETUP 5-3, 5-7  
SYSTEM SETUP  
    Touch Buzzer sound 5-3

## T

Terminals  
    Crimp On Ring 3-5  
Termination code  
    Data Format 4-4  
TFT Color LCD viii  
Touch Interface Data 4-3  
Touch Panel Command 4-1  
Touch Panel Commands 4-5  
Touch Panel Coordinate Data 4-3  
Touch panel coordinates 5-3  
Touch Panel Data Calibration  
    CALIB.EXE 5-7  
Touch Panel Does Not Work  
    Troubleshooting 6-4  
Touch panel input  
    Infinite Wait 5-5  
    Instant Return 5-5  
    Non-renewing 5-5  
Touch Panel Input Drivers  
    Bundled Software 5-3  
Touch Panel programs  
    Floppy disk ix  
Troubleshooting 6-1  
TT-WIN95 4-3

## U

User's Manual ix

## V

Vector number 5-4  
Vertical Installation 3-2  
VGA board vii  
VGA text mode  
    Right side 80 pixels 2-3  
Viewing angle  
    Definition 2-2  
Voltage Transformer 3-6

## W

Wiring 3-5  
    Grounding 3-7  
    Input/Output Signal Lines 3-7  
    Power Cable 3-5  
    Power Supply 3-6

# *MEMO*