

Pro-face

Factory Gateway

User Manual

(Pro-Designer Compatible)

Preface

Thank you for purchasing the Pro-face Graphic Logic Controller Factory Gateway Series (hereby referred to as “Factory Gateway” or “Factory Gateway unit”).

This unit is designed to be connected to an External Device (PLC, etc.) that does not have its own Ethernet interface, via the Pro-Designer system’s Ethernet connection. Pro-Designer also allows the Factory Gateway unit to communicate with a host-level PC without specialized programming. This allows data collection and sharing of data with other PLC units.

Also, Pro-Designer’s packaged software, Pro-eView, allows you to display and to operate a maintenance screen from a host-level or a remote PC.

In this manual’s examples, the Mitsubishi MELSEC-AnA Series PLC is used whenever possible, connected in a one-to-one relationship with a Factory Gateway unit.

< Note >

1. It is forbidden to copy the contents of this manual, in whole or in part, except for the user’s personal use, without the express permission of Digital Electronics Corporation of Japan.
2. The information provided in this manual is subject to change without notice.
3. This manual has been written with care and attention to detail; however, should you find any errors or omissions, contact Digital Electronics Corporation and inform them of your findings.
4. Please be aware that Digital Electronics Corporation shall not be held liable by the user for any damages, losses, or third party claims arising from any uses of this product.

All Company/Manufacturer names used in this manual are the registered trademarks of those companies.

© Copyright 2002 Digital Electronics Corporation

Table of Contents

Preface	1
Essential Safety Precautions	4
General Safety Precautions	7
Factory Gateway Models	8
Package Contents	8
UL/c-UL (CSA) Application Notes	9
CE Marking Notes	9
Documentation Conventions	10

CHAPTER 1 INTRODUCTION

1.1 System Design	1-1
1.2 Accessories	1-3

CHAPTER 2 SPECIFICATIONS

2.1 General Specifications	2-1
2.1.1 Electrical	2-1
2.1.2 Environmental	2-2
2.1.3 Structural	2-3
2.2 Functional Specifications	2-3
2.2.1 Memory	2-3
2.2.2 Clock	2-3
2.2.3 Interfaces	2-3
2.3 Interface Specifications	2-4
2.3.1 Serial Interface (COM)	2-4
2.4 Part Names and Functions	2-6
2.5 Dimensions	2-8

CHAPTER 3 INSTALLATION AND WIRING

3.1 Installation	3-1
3.2 Wiring Cautions	3-2
3.2.1 Connecting the Power Cord	3-2
3.2.2 Connecting the Power Supply	3-4
3.2.3 Grounding	3-5
3.2.4 I/O Signal Line Cautions	3-6
3.3 Tool Connector	3-6
3.4 Ethernet Cable Connector	3-7

3.5 IP Address Settings 3-8

CHAPTER 4 TROUBLESHOOTING

4.1 Troubleshooting..... 4-1
4.1.1 LED Status Indicators 4-2
4.1.2 Diagnosing Problems 4-3
4.2 Periodic Check Points 4-4

Essential Safety Precautions

This manual includes procedures that must be followed to operate the FACTORY GATEWAY correctly and safely. Be sure to read this manual and any related materials thoroughly to understand the correct operation and functions of the FACTORY GATEWAY unit.

■ Safety Symbols

Please pay attention to the following safety symbols and their meanings:



Indicates situations that may result in major machine damage, severe bodily injury, or death if the instructions are not followed.



Indicates situations that may result in damage to the machinery, or minor bodily injury if the instructions are not followed.

WARNINGS

System Design

- **Please design your system so that equipment will not malfunction due to a communication fault between the Factory Gateway and its host controller. This is to prevent any possibility of bodily injury or material damage.**
- **Do not use the Factory Gateway unit as a warning device for critical alarms that can cause serious operator injury, machine damage or production stoppage. Critical alarm indicators and their control/activator units must be designed using stand-alone hardware and/or mechanical interlocks.**
- **The Factory Gateway is not appropriate for use with aircraft control devices, aerospace equipment, central trunk data transmission (communication) devices, nuclear power control devices, or medical life support equipment, due to these devices' inherent requirements of extremely high levels of safety and reliability.**

 **WARNINGS**

- When using the Factory Gateway with transportation vehicles (trains, cars and ships), disaster and crime prevention devices, various types of safety equipment, non life-support related medical devices, etc. redundant and/or fail-safe system designs should be used to ensure the proper degree of reliability and safety.

Installation

- High voltage runs through the Factory Gateway. Never disassemble the Factory Gateway, otherwise an electric shock can occur.
- Do not modify the Factory Gateway unit. Doing so may cause a fire or an electric shock.
- Do not use the Factory Gateway in an environment where flammable gasses are present, since operating the Factory Gateway may cause an explosion.

Wiring

- To prevent an electric shock, be sure to confirm that the Factory Gateway's power cord is not connected to the main power when connecting any cords, cables or lines to the Factory Gateway.
- Be sure to replace the Factory Gateway's plastic terminal block cover after wiring is completed, since operating the Factory Gateway without the cover may lead to an electric shock.
- Do not use power beyond the Factory Gateway's specified voltage range. Doing so may cause a fire or an electric shock.

Maintenance

- The Factory Gateway uses a lithium battery for backing up its internal clock data. If the battery is incorrectly replaced, the battery may explode. To prevent this, please do not replace the battery yourself. When the battery needs to be replaced, please contact your local Factory Gateway distributor.



CAUTIONS

Installation

- Be sure to securely connect all cable connectors to the Factory Gateway. A loose connection may cause incorrect input or output.

Wiring

- Ground the Factory Gateway's FG line separately from other units' FG lines. Putting these FG lines too close may cause an electric shock or unit malfunction. Be sure to use a grounding resistance of 100Ω or less and a 2mm^2 or thicker wire, or your country's applicable standard.
- When wiring the Factory Gateway, be sure that the rated voltage and terminal layout are within the designated range. If the voltage supplied differs from the rated voltage, or incorrect wiring or grounding is performed, it may cause a fire or unit malfunction.
- Use only the designated torque to tighten the Factory Gateway's terminal block screws. If these screws are not tightened firmly, it may cause a short-circuit, fire, or Factory Gateway malfunction.
- Be careful that metal filings and wiring debris do not fall inside the Factory Gateway, since they can cause a fire, Factory Gateway malfunction, or incorrect operation.

Unit Disposal

- When this unit is disposed of, it should be done so according to your country's regulations for similar types of industrial waste.

General Safety Precautions

- Do not install the Factory Gateway where the ambient temperature can exceed the allowed range. Doing so may cause the Factory Gateway to malfunction or shorten its operation life.
- Do not restrict or limit the Factory Gateway's naturally occurring rear-face ventilation, or store or use the Factory Gateway in an environment that is too hot.
- Do not use this unit in areas where large, sudden temperature changes can occur. These changes can cause condensation to form inside the unit, possibly causing the unit to malfunction.
- Do not allow water, liquids, metal or charged particles to enter inside the Factory Gateway's case, since they can cause either a Factory Gateway malfunction or an electrical shock.
- Do not use or store the Factory Gateway in direct sunlight, or in excessively dusty or dirty environments.
- Do not store or use the unit where strong jolting or excessive vibration can occur.
- Do not store or use the Factory Gateway where chemicals (such as organic solvents, etc.) and acids can evaporate, or where chemicals and acids are present in the air.
Corrosive chemicals: Acids, alkalies, liquids containing salt
Flammable chemicals: Organic Solvents
- Do not use paint thinner or organic solvents to clean the Factory Gateway.
- Do not connect or disconnect the communication cable to the host machine while the power is ON.

Factory Gateway Models

The Factory Gateway Series in this manual refers to the following Factory Gateway model number:

Series Name	Model Number	Comments
FactoryGateway	FGW-SE41-24V	UL/c-UL (CSA) Approved CE Marked

Package Contents

The following items are included in the Factory Gateway’s package. Before using the Factory Gateway, please confirm that all items listed here are present.

- Factory Gateway Unit (1)
(FGW-SE41-24V)

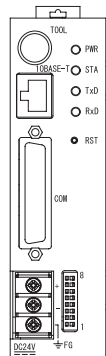

- Installation Guide (1)

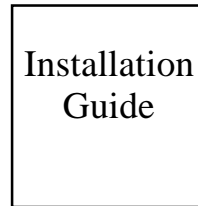

This unit has been carefully packed, with special attention to quality. However, should you find anything damaged or missing, please contact your local Factory Gateway distributor immediately.

UL/c-UL (CSA) Application Notes

The FGW-SE41-24V is a UL/c-UL (CSA) recognized unit. (UL File No. E220851)

The FGW-SE41-24V unit conforms to the following standards.

- UL508 Electrical Control System for Industry

- CAN/CSA-C22.2 No.1010-1

(Safety requirements for electrical equipment for measurement and laboratory use)

FGW-SE41-24V (UL Registration Model: 3080034-01)

<Notes>

- The Factory Gateway must be installed in other equipment.

- If the unit is installed in an area with no air conditioning system, be sure to attach the DIN rail to the rear of the unit. Also, be sure the unit is installed so it is at least 100 mm away from all of the unit's directions except the rear side. If these requirements are not met, the heat generated by the unit's internal components may cause the unit to fail to meet UL standards requirements.

- The power supply unit connected to the I/O unit must be a UL/c-UL (CSA) approved Class 2 power supply unit or Class 2 transformer*¹. When the Factory Gateway or multiple I/O units under load are operated with a single power supply, the amount of current consumption and full-load current of the I/O units must be within the rated load of the Class 2 power supply unit or Class 2 power supply transformer. Be aware that the number of points which can be turned ON simultaneously may be limited, depending on the amount of load and load current value.

**1. A Class 2 power supply unit or Class 2 power supply transformer is 30V and, at 8A or less output, less than 100VA. (Prescribed by National Electrical Code.)*

CE Marking Notes



The FGW-SE41-24V is a CE Marked unit that conforms to EMC directives EN55011 Class A and EN61000-6-2.

<Caution>

While this unit is officially marked as conforming to the relevant EMC directives, it is the user's final application of this unit in a larger system (i.e. the machinery, wiring, control panel, installation method, etc.) that will determine if this unit maintains or loses this conformance marking. Therefore, it is strongly advised that the user investigate and confirm whether their overall system (i.e. all related machinery and equipment) also conforms with these EMC directives.

Documentation Conventions

The list below describes the documentation conventions used in this manual.

Symbol	Meaning
	Indicates important information or procedures that must be followed for correct and risk-free software/device operation.
Screen Creation Software	Indicates the Pro-Designer (Ver. 4.0 or later)
Pro-eView	Indicates the software that displays screens created by the Screen Creation Software using Internet Explorer.
PLC	Abbreviation for Programmable Logic Controller.
*	Indicates additional important information.
	Indicates an important hint or explanation.

Chapter 1 Introduction

- 1. System Design
- 2. Accessories

1.1 System Design

The following diagram represents the main selection of devices connectable to the Factory Gateway unit.

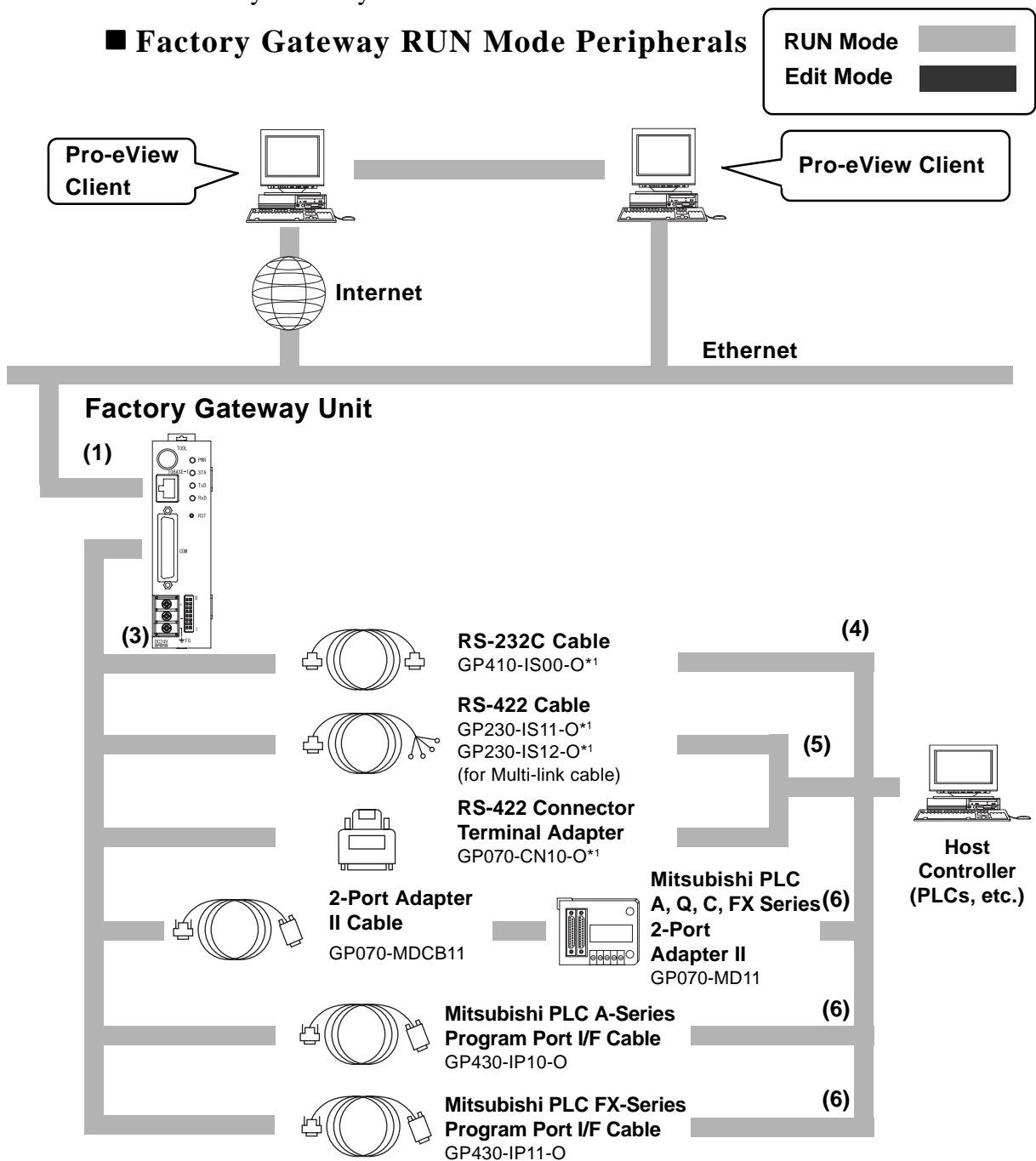

*1. Certain PLC types and models cannot be connected.

Reference Pro-Designer On-line Help

Chapter 1 – Introduction

■ Factory Gateway Edit Mode Peripherals

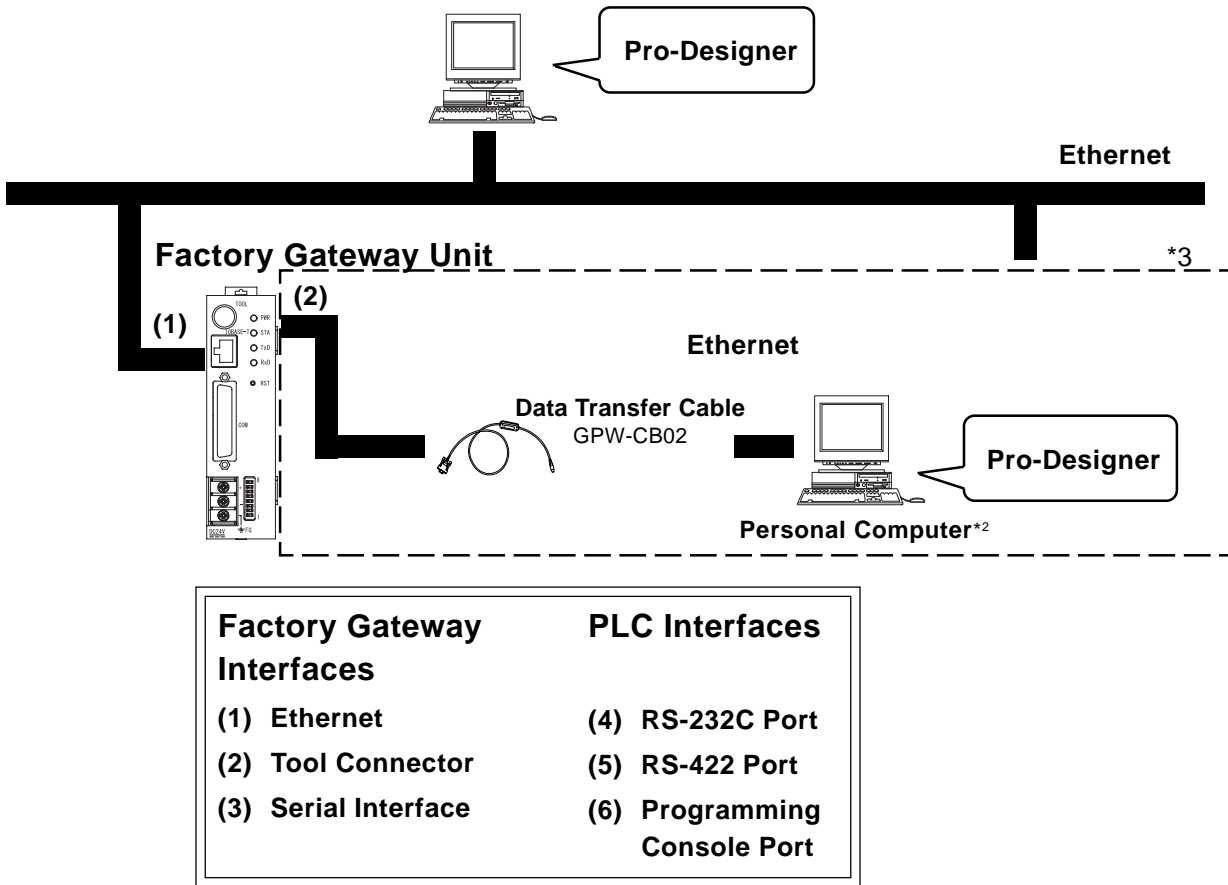

*2. For the full range of compatible PCs, refer to the following manual.

Reference *Pro-Designer On-line Help*

*3. Normally, maintenance (data transfer) is possible using an Ethernet network. However, depending on the data transfer cable used, a Factory Gateway System Error may occur, preventing communication.

1.2 Accessories

All optional equipment listed here is produced by Digital Electronics Corporation.

■ Available Software

Product Name	Model No.	Description
Pro-Designer Ver. 4.0 or later (including Pro-eView)	PS-DWE01-V40	Software used to create screen data and to set protocol to use the remote monitoring feature (Pro-eView) or the data sharing feature of Internet Explorer on Factory Gateway.
Pro-eView License	PS-EPR01	Software license to use Pro-eView on Factory Gateway.

■ Tool Connector

Product Name	Model No.	Description
Data Transfer Cable ^{*1}	GPW-CB02	Cable to connect Factory Gateway with a PC and to transfer screen data from Pro-Designer.

**1. Normally, maintenance (data transfer) is possible using an Ethernet network. However, depending on the data transfer cable used, a Factory Gateway System Error may occur, preventing communication.*

■ Serial Interfaces

Product Name	Model No.	Description
RS-232C Cable ^{*1}	GP410-IS00-O	Interface cables between the host (PLC) and the Factory Gateway.
RS-422 Cable ^{*1}	GP230-IS11-O	
RS-422 Terminal Block Adapter ^{*1}	GP070-CN10-O	Conversion adapter to convert serial data to RS-422 format.
2 Port Adapter II	GP070-MD11	Interface unit that allows use of both Factory gateway and Mitsubishi A, Q, C and FX series equipment in the same location.
2 Port Adapter II Cable	GP070-MDCB11	Connects the Factory Gateway to the 2-Port Adapter II.
Mitsubishi A Series Programming Port I/F Cable	GP430-IP10-O	Connects directly to Mitsubishi's PLC I/F Programming Console. Simultaneous use of program console, however, is not possible.
Mitsubishi FX Series Programming Port I/F Cable	GP430-IP11-O	

**1. For details about the range of connectable PLCs:*

Reference *Pro-Designer On-line Help*

■ Maintenance Items

Product Name	Model No.	Description
Connector Cover	PS-BH00	Side face connector cover.

Memo

Chapter

2 Specifications

1. General Specifications
2. Functional Specifications
3. Interface Specifications
4. Part Names and Functions
5. Dimensions

2.1 General Specifications

2.1.1 Electrical

Rated Voltage	DC 24V
Rated Voltage Range	DC 19.2V to DC 28.8V
Allowable Voltage Drop	10ms max.
Power Consumption	10W max.
In-Rush Current	30A max.
Voltage Endurance	AC 500V 20mA for 1 minute (between charging and FG terminals)
Insulation Resistance	10M Ω or more at DC 500V (between charging and FG terminals)

Chapter 2 – Specifications

2.1.2 Environmental

Ambient Operating Temperature	0°C to +55°C
Storage Temperature	-20°C to +60°C
Ambient Humidity	10%RH to 90%RH (non-condensing, wet bulb temperature: 39°C max.)
Storage Humidity	10%RH to 90%RH (non-condensing, wet bulb temperature: 39°C max.)
Air Purity (Dust)	0.1mg/m ³ max. (non-conductive levels)
Atmosphere	Free of corrosive gasses
Atmospheric Endurance (Factory Gateway Operation Altitude)	800hPa to 1,114hPa (2000 meters max.)
Shock Resistance	IEC61131-2 (JIS B 3501) compliant (147m/s ² , three times for each [X, Y, Z] direction)
Vibration Resistance	IEC61131-2 (JIS B 3501) compliant When Vibration is NOT Continuous 10Hz to 57Hz 0.075mm, 57Hz to 150Hz 9.8m/s ² When Vibration is Continuous 10Hz to 57Hz 0.035mm, 57Hz to 150Hz 4.9m/s ² (10 times [80 min.] for each [X, Y, Z] direction)
Noise Immunity (via noise simulator)	Noise Voltage: 1200Vp-p, Pulse Duration: 1μs Rise Time: 1ns
Electrostatic Discharge Immunity	Contact Discharge Method 6kV (complies with IEC 61000-4-2 Level 3)

2.1.3 Structural

Grounding	100Ω max., or your country's applicable standard
External Dimensions	W37mm x H131mm x D105mm [1.46 in.x 5.16 in. x 4.13 in.]
Weight	Approx. 0.6 kg [1.32 lb]
Cooling Method	Natural air circulation

2.2 Functional Specifications

2.2.1 Memory

Application	4MB FLASH EPROM
--------------------	-----------------

2.2.2 Clock

Clock Accuracy	±65 seconds/month (at room temperature)
-----------------------	---



Note: The FACTORY GATEWAY unit's internal clock has a slight error. At normal operating temperatures and conditions, with the FACTORY GATEWAY operating from its lithium battery, the degree of error is 65 seconds per month. Variations in operating conditions and battery life can cause this error to vary from -380 to +90 seconds per month. For systems where this degree of error will be a problem, the user should be sure to monitor this error and make adjustments when required.

Reference *Pro-Designer On-line Help*

2.2.3 Interfaces

Serial Interface (COM)	Asynchronous Transmission: RS232C/RS422 Data Length: 7 or 8 bits Stop Bit: 1 or 2 bits Parity: None, Odd or Even Data Transmission Speed: 2,400 to 115,200bps
Ethernet Interface	IEEE802.3, 10BASE-T
Tool Connector	Asynchronous TTL level nonprocedural command I/F Used for transferring data between the Pro-Designer and the Factory Gateway.

2.3 Interface Specifications

2.3.1 Serial Interface (COM)

This interface can be either RS-232C or RS-422. It connects the FACTORY GATEWAY to the Host (PLC). This interface uses a socket-type connector.

Pin Assignments	Pin #	Signal Name	Condition
	1	FG	Frame ground
	2	SD	Send data (RS-232C)
	3	RD	Receive data (RS-232C)
	4	RS	Request send (RS-232C)
	5	CS	Clear send (RS-232C)
	6	DR	Data Set Ready (RS-232C)
	7	SG	Signal ground
	8	CD	Carrier detect (RS-232C)
	9	TRMX	Termination (RS-422)
	10	RDA	Receive data A (RS-422)
	11	SDA	Send data A (RS-422)
	12	NC	No connection (Reserved)
	13	NC	No connection (Reserved)
	14	VCC	5V±5% output 0.25A
	15	SDB	Send data B (RS-422)
	16	RDB	Receive data B (RS-422)
	17	RI	Ring Indicate (RS-232C)
	18	CSB	Clear send B (RS-422)
	19	ERB	Enable receive B (RS-422)
	20	ER	Enable receive (RS-232C)
	21	CSA	Clear send A (RS-422)
	22	ERA	Enable receive A (RS-422)
	23	NC	No connection (Reserved)
	24	NC	No connection (Reserved)
	25	NC	No connection (Reserved)

Recommended Parts

Connector	Dsub25pin plug XM2A-2501	(OMRON)
Cover	Dsub25pin cover XM2S-2511	(OMRON)
	Dsub25pin cover XM2S-2521	(OMRON)
	Jack Screws XM2Z-0071	(OMRON)
Cable	CO-MA-VV-SB5P x 28AWG	(Hitachi Cable Ltd.)



Use rough metric type M2.6x0.45 p threads used to secure the cable's set screws.

Reference *Pro-Designer On-line Help*

Chapter 2 – Specifications



Use the following instructions to create your own cable:

With an RS-422 cable:

- The following pins must be shorted as follows:
 - #18 (CSB) and #19 (ERB)
 - #21 (CSA) and #22 (ERA)
- Connecting the RS-422 cable's #9 (TRMX) and #10 (RDA) pins inserts a termination resistance of 100Ω between #10 (RDA) and #16 (RDB).
- When making a cable for a Memory Link system, use a 4-wire type cable.

With an RS-232C cable:

- Do NOT use the following pins:
 - #9 (TRMX), #10 (RDA), #11 (SDA), #15 (SDB), #16 (RDB), #18 (CSB), #19 (ERB), #21 (CSA), #22 (ERA)
- Connect the #1 (FG) terminal only if it is required by a connected device.



-
- **This FACTORY GATEWAY unit's serial port is not isolated. When the host (PLC) unit is also not isolated, and to reduce the risk of damaging the RS-422 circuit, be sure to connect the #7 SG (Signal Ground) terminal.**
 - **Pin #14 (VCC) DC 5V Output is not protected. To prevent damage or unit malfunction, use only the designated level of current.**
-

2.4 Part Names and Functions

A : Tool Connector

Connects the data transfer cable when transferring data for maintenance.

B : Ethernet I/F (10BASE-T)

Provides a 10BASE-T interface.

C : Network Status LED

These LEDs are positioned vertically and indicate the Ethernet data transfer status.

Location	Color	Indicates	Not Lit Indicates
Upper	Green	Ready to transfer data	Not connected to network / Network trouble
Lower	Yellow	Transferring data	Not transferring data

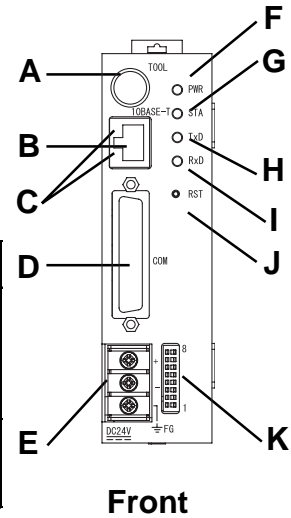

D : Serial I/F(Dsub 25pin)

Used for the Dsub25 pin's RS-232C and RS-422 cables. Is connected to the Host (PLC.)

Reference 2.3 Interface Specifications

E : Power Input Terminal Block

Connects the power cord.

F : Power LED (PWR)

This LED indicates the Factory Gateway's status.

LED	Factory Gateway Status
Green	Normal operation
Orange	Transferring data
Red	Unit malfunction
Not Lit	No power is available

G : Error Status LED (STA)

LED	Factory Gateway Status
Green	Normal operation
Orange	System program error/Data error
Red	Run-time Application program error including a PLC communication error
Not Lit	Unit malfunction

Reference For details, see 4.1.1 LED Status Indicators

- H : Serial I/F (TxD)
When this indicator blinks, data is being sent.
- I : Serial I/F (Rx/D)
When this indicator blinks, data is being received.
- J : Reset Switch (RST)
Resets the Factory Gateway unit.
- K : DIP Switches
When Pro-Designer Runtime is installed using an Ethernet network in either a new (factory settings) Factory Gateway unit, or a Factory Gateway unit that has already been set up using GP-PRO/PBIII system data, be sure to turn Factory Gateway unit dip switches 5 and 6 “ON” (System Overwrite Enabled).
If Pro-Designer runtime has been previously installed, the Factory Gateway unit's dip switches do not need to be changed.
The Factory Gateway unit's factory-shipped dip switch settings are “OFF”. This setting is recommended for protecting the Factory Gateway unit's data.

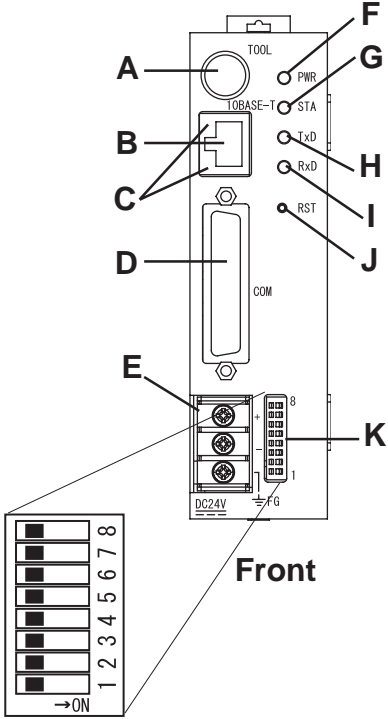

- L : DIN Rail Attachment Holder
 - M: Rotary Switches
These switches are used to set the unit's IP Address. The factory settings are “0”.
- Reference** For details, see 3.5 Setting IP Addresses

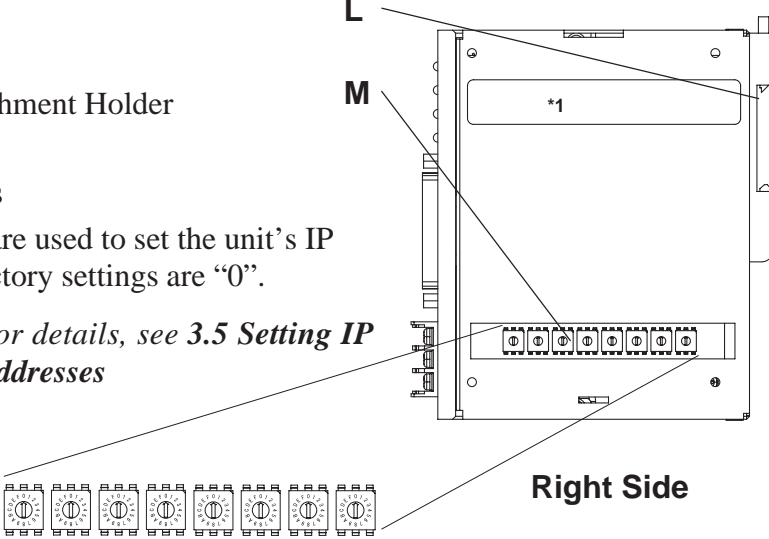

*1. This section is used only for maintenance by Pro-face. Do not open this cover.

2.5 Dimensions

Unit:mm [in.]

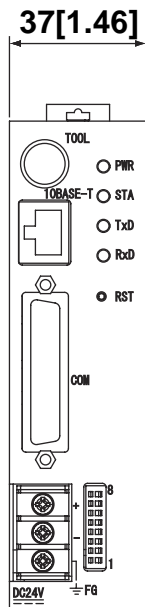

Front

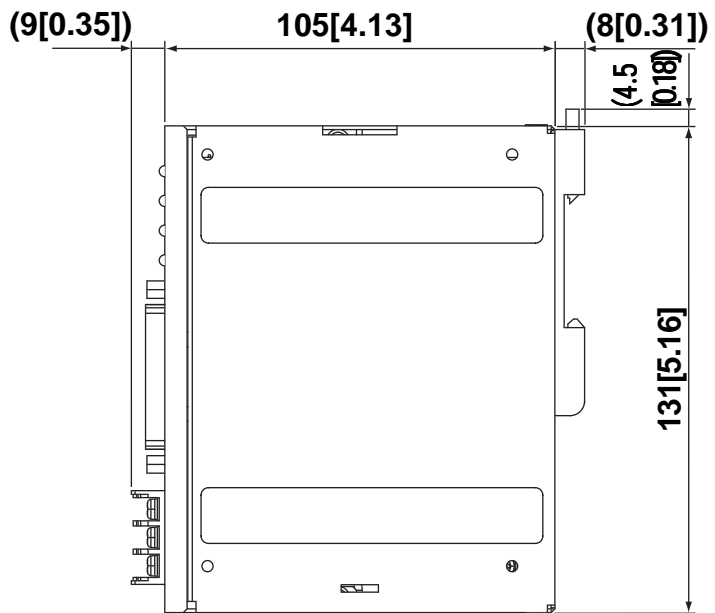

Right Side

Chapter

3 Installation and Wiring

1. Installation
2. Wiring Cautions
3. Tool Connector
4. Ethernet Cable Connector
5. IP Address Settings

3.1 Installation

The following information explains how to attach a 35mm DIN rail to the Factory Gateway.

◆ Attachment

Place the unit's curved, bottom lip over the bottom of the DIN rail, and tilt the unit up until the top face attachment clip clicks into place.

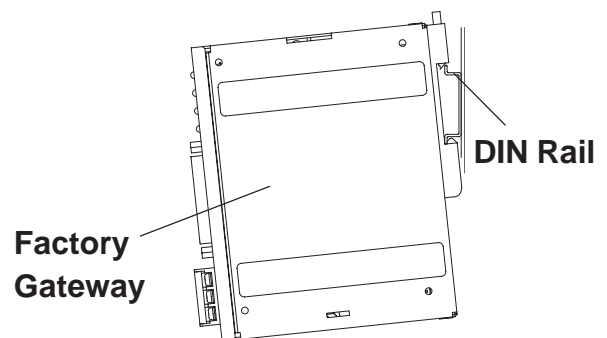

- Be sure that the top and bottom faces of the unit are correctly oriented and that the unit is vertical. Incorrect installation may prevent heat from dissipating correctly.
- When removing the unit from the attachment clips, hold the unit with your hand to prevent it from falling. To prevent the Factory Gateway unit from being dislodged from the DIN Rail due to being struck or bumped from the side, the following Stabilizer Clips are recommended.

BNL5P (IDEC Corporation)

HDV-1 (TOYO GIKEN Corporation)

◆ Removal

Use a standard screwdriver to force the unit's attachment clip up until the top of the unit is freed from the rail. Next, tilt the unit down and remove.

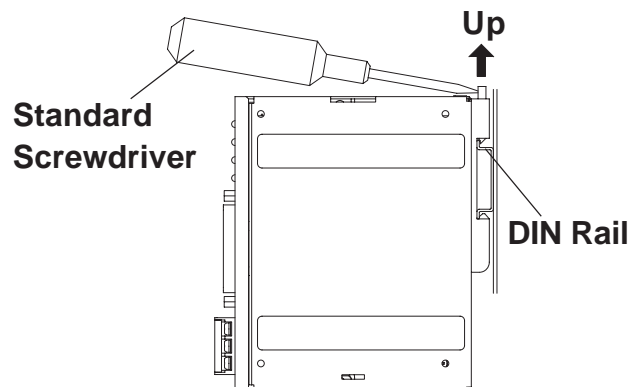

When removing the unit from the attachment clips, hold the unit with your hand to prevent it from falling.

3.2 Wiring Cautions

3.2.1 Connecting the Power Cord

WARNINGS

- To avoid an electric shock, prior to connecting the Factory Gateway's power cord terminals to the power terminal block, confirm that the Factory Gateway's power supply is completely turned OFF, via a breaker, or similar unit.
- The Factory Gateway FGW-SE41-24V unit is designed to use only DC24V input. Any other power level can damage both the Factory Gateway and the power supply.
- Since there is no power switch on the Factory Gateway unit, be sure to attach a breaker type switch to its power cord.
- When the FG terminal is connected, be sure the wire is grounded. Otherwise, an electric shock can occur when the unit is broken.



- To avoid a short caused by loose ring terminals, be sure to use ring terminals with an insulating sleeve.
- When the FG terminal is connected, be sure the wire is grounded. Not grounding the Factory Gateway unit will result in excess noise and vibration.
- The SG and FG terminals are connected internally in the Factory Gateway unit.
- When connecting the SG line to another device, be sure that the design of the system does not produce a shorting loop.



- Wherever possible, use thick wires (max. 2 mm²) for power terminals, and twist the wire ends before attaching the ring terminals.
- Be sure to use the following size ring terminals.*¹

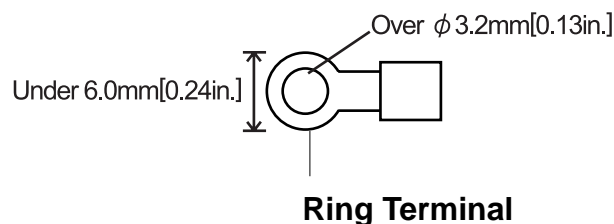

*¹ Suggested Ring Terminal : V2-MS3 (made by JST)

Chapter 3 – Installation and Wiring

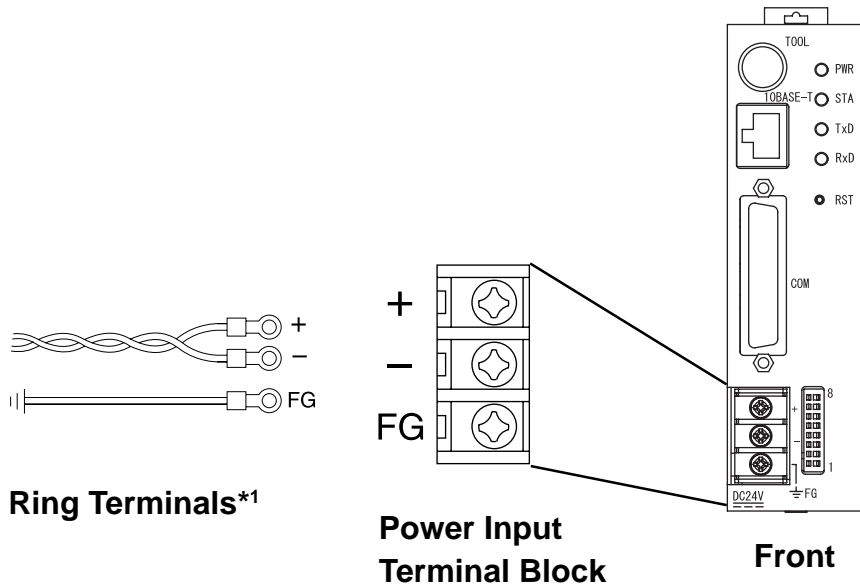

+	Positive Electrode
-	Negative Electrode
FG	Frame ground (connected to FGW chassis)

When connecting the power cord, be sure to follow the procedures given below.

1. Confirm that the Factory Gateway's Power Cord is disconnected from the power supply.
2. Use a screwdriver to remove the Power Input Terminal Block's clear plastic cover.
3. Remove the screws from the middle three (3) terminals, align the Ring Terminals and reattach the screws.

Reference See 3.2.2 *Connecting the Power Supply*



- Confirm that the wires are connected correctly.
- The torque required to tighten these screws is 0.5 N•m.

4. Replace the Power Input Terminal Block's clear plastic cover.

*1 Suggested Ring Terminal : V2-MS3 (made by JST)

Chapter 3 – Installation and Wiring

3.2.2 Connecting the Power Supply

- When supplying power to the Factory Gateway unit, separate the input/output and operation unit lines (see Diagram 1).
- To increase the noise resistance quality of the power cord, twist each power wire before attaching the Ring Terminal.
- The power supply cord must not be bundled or positioned close to main circuit lines (high voltage, high current), or input/output signal lines (see Diagram 2).
- Connect a lightning surge absorber (see Diagram 3) to deal with power surges.
- To avoid excess noise, make the power cord as short as possible.



- **Ground the surge absorber (E1) separately from the Factory Gateway unit (E2).**

- **Select a surge absorber with a maximum circuit voltage that is greater than that of the power supply's peak voltage.**

Dia. 1

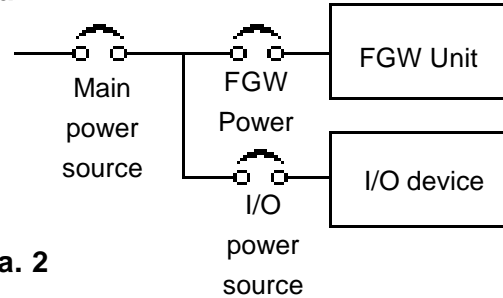

Dia. 2

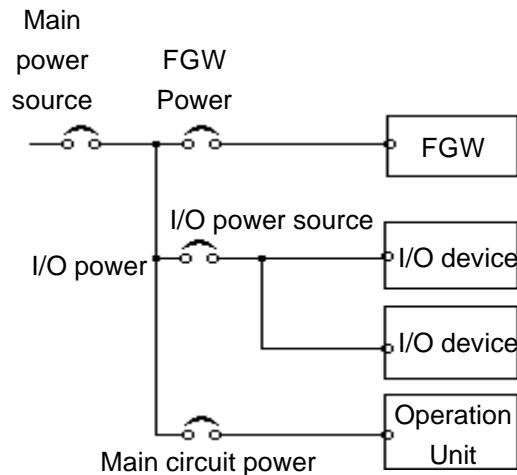

Dia. 3

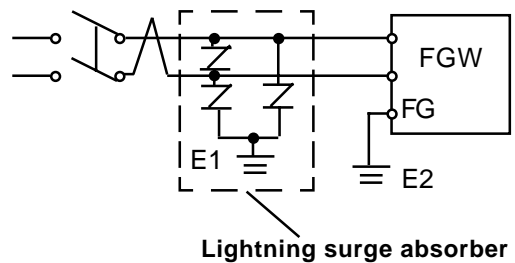

3.2.3 Grounding



CAUTION

Do NOT use common grounding, since it can lead to an accident or machine breakdown.

Connect the FG terminal found on the back of the Factory Gateway unit to an exclusive ground (diagram A).

(A) Excluding Grounding (BEST)



- Make sure that the grounding resistance is less than 100Ω.
- The FG and SG lines are connected internally in the Factory Gateway.
- The grounding wire should have a cross-sectional area of at least 2 mm². Create the grounding point as close to the Factory Gateway unit as possible, and keep the wire as short as possible. Replace thin wire with a thicker wire, and place it in a duct.
- When connecting the SG line to another device, be sure that the design of the system does not produce a shorting loop.

If exclusive grounding is not possible, use a common connection point (diagram B).

(B) Common Grounding (OK)

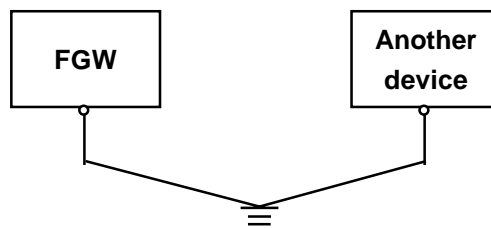

(C) Common Grounding (Not OK)

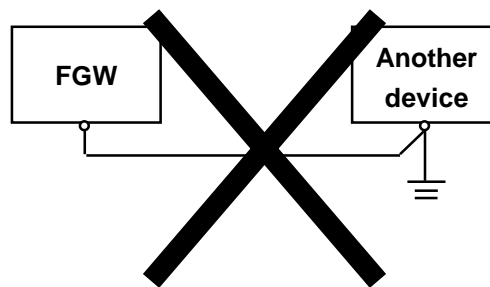

If the equipment does not function properly when grounded, disconnect the ground wire from the FG terminal.

Chapter 3 – Installation and Wiring

3.2.4 I/O Signal Line Cautions

- To help prevent noise and interference problems, separate all communication lines from power lines by placing them in a separate duct.
- If different wires must be placed in the same duct, separate them with an earthed/ grounded divider.

3.3 Tool Connector

A data transfer cable can be attached to the Factory Gateway unit's tool connector. The location of the Factory Gateway unit's tool connector is shown in the following diagram.

WARNINGS

To prevent an electrical shock, be sure to unplug the Factory Gateway unit's power cord from the main power supply prior to attaching or detaching any connectors to or from the Factory Gateway.

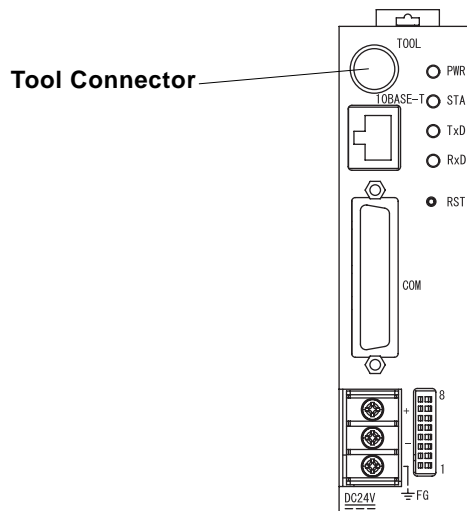

Front

3.4 Ethernet Cable Connector

The Factory Gateway Ethernet interface is IEEE802.3 compliant, and transmits data at 10 Mbps. The Ethernet connector's location is shown below.

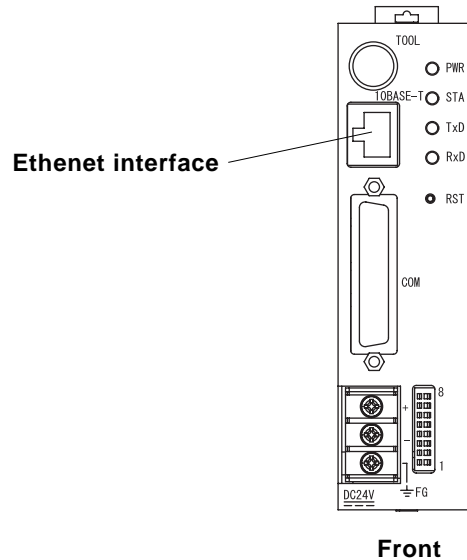

- Pro-face strongly recommends that a trained engineer install your Ethernet network.
- You may not be able to use the 1:1 connection by a cross cable depending on PCs or network cards. Be sure to connect those with a hub.

3.5 IP Address Settings

To set the Factory Gateway unit's IP address, the 8 side face rotary switches are used.

To set these switches, you must first remove the right face Rotary Switch Cover. The factory settings are all "0".

Also, the Factory Gateway unit's IP address is set using HEX.

The example below uses an IP address (DEC) of 192.168.0.1.

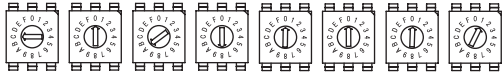
	IP Address			
Decimal	192	168	0	1
Hexadecimal	C0	A8	00	01
Rotary Switch Settings				



- Be sure to enter all IP address settings prior to connecting the Factory Gateway unit to the power supply. If power is connected to the Factory Gateway unit prior to setting these switches, a communication (illegal IP address) error will occur. In this case, please disconnect the Factory Gateway unit's power supply, set these switches, and reconnect the power supply.
- The "Subnet Mask" and "Default Gateway" settings are not set via these switches. They are set using the Pro-Designer software and then sent to the Factory Gateway unit.

Reference *Pro-Designer On-line Help*

- The IP Addresses should be set as follows:
00.00.00.01 -> 7F.FF.FF.FE (0.0.0.1 to 127.255.255.254)
80.00.00.01 -> BF.FF.FF.FE (128.0.0.1 to 191.255.255.254)
C0.00.00.01 -> DF.FF.FF.FE (192.0.0.1 to 223.255.255.254)
- After setting the IP Addresses, be sure to reattach the cover.



Chapter 4 Troubleshooting

4.1 Troubleshooting

The following information explains how to troubleshoot the Factory Gateway unit. The first steps should always be to check the following items.

- Is the Factory Gateway receiving the correct level of power?
- Is the Device/PLC receiving the correct level of power?
- Is the Factory Gateway correctly connected to the Device/PLC?
- Is the Factory Gateway unit's current protocol data correct for the type of Device/PLC that is connected?

Chapter 4 – Troubleshooting

4.1.1 LED Status Indicators

The Factory Gateway unit uses two LED indicators (PWR and STA) to display the status of the Factory Gateway unit. The following table describes the problems indicated by these LEDs, and gives suggestions for how to solve each problem.

Lamp Name		Problem/Condition	Possible Solution(s)
PWR	STA		
OFF	OFF	No power	Power supply is not operating.
	Green	Normally OFF	If lit, a hardware error has occurred.
	Red		
	Orange		
Green	OFF	System Program Error	Reinstall the run-time system using the run-time installer via the data transfer cable.
		Factory Gateway Error	If lit, a hardware error has occurred.
	Green	No problem	(Run-time system is operating Normally)
	Red	System Program Error	Reinstall the run-time system using the run-time installer via the data transfer cable.
		Factory Gateway Error	If lit, a hardware error has occurred.
	Orange	Incorrect IP Address	Correct the unit's current rotary switch IP Address settings.
		Run-time Application Error	Confirm the contents of system variables for storing error messages using Pro-eView or the data-sharing feature, and perform appropriate treatment depending on each error.
	Red	OFF	Normally OFF
Green			
Red			
Orange			
Orange	OFF	System Program Error	Reinstall the run-time system using the run-time installer via the data transfer cable.
		Factory Gateway Error	Possible hardware error.
	Green	Transferring data	(Transferring data)
	Red	System Program Error	Reinstall the run-time system using the run-time installer via the data transfer cable.
		Factory Gateway Error	Possible hardware error.
	Orange	Incorrect IP Address	Correct the unit's current rotary switch IP Address settings.
		Run-time Application Error	Confirm the contents of system variables for storing error messages using Pro-eView or the data-sharing feature, and perform appropriate treatment depending on each error.



When a hardware error occurs, please contact your local Pro-face distributor for service and repair.

4.1.2 Diagnosing Problems

The following solutions may solve the problem.

■ Unable to transfer data

CAUSE1: The network settings are incorrect.

SOLUTION: Enter them correctly in Pro-Designer, and transfer the project file again.

CAUSE2: The protocol settings are incorrect.

SOLUTION: Using Pro-Designer, confirm if the correct Device/PLC has been set. If an incorrect protocol has been set, correct the setting and transfer the project file again.

CAUSE3: The protocol communication settings are incorrect.

SOLUTION: Enter them correctly in Pro-Designer, and transfer the project file again.

■ Unable to Refer to Data or Perform Data-sharing with Pro-eView

CAUSE1: Pro-Designer/Data-Sharing data settings are incorrect.

SOLUTION: Enter them correctly in Pro-Designer, and transfer the project file again.

CAUSE2: The network settings are incorrect.

SOLUTION: Enter them correctly in Pro-Designer, and transfer the project file again.



Note: For troubleshooting details, refer to Pro-Designer On-line Help.

4.2 Periodic Check Points

To keep your Factory Gateway unit in good condition, be sure to inspect the following points periodically.

Operation Environment

- Is the operating temperature within the allowable range (0° C to 55° C)?
- Is the operating humidity within the specified range (10%RH to 90%RH, wet bulb temperature of 39° C or less)?
- Is the operating atmosphere free of corrosive gasses?

Electrical Specifications

- Is the input voltage (DC 19.2V to DC 28.8V) appropriate?

Related Items

- Are all power cords and cables connected properly? Have any become loose?
- Is the DIN rail holding the unit securely?