

Rear Cover(CA1-RCVLRG-01) Desktop Stand(CA1-STDLRG-01) Installation Guide

Thank you for purchasing Pro-face's Rear Cover.

This Rear Cover can be attached to the following products: PS-600G Series, PS-500P Series, GP-2500/2600 Series, GLC2600 Series, FP-2500/2600 Series, and FP-3500T/3600T/3650T Series units (hereafter referred to as the "Unit".)

Using this Rear Cover in combination with the separately sold Desktop Stand or Wall Mount Adaptor enables any of the Units to be mounted on a desk or wall.



The Rear Cover is not CE marked or UL/c-UL(CSA) compliant. Therefore, be aware that when it is used in combination with a product that is CE marked and UL/c-UL(CSA) compliant, that product will lose its conformance with these standards.

All Company/Manufacturer names used in this manual are the registered trademarks of those companies.

Safety Precautions

This Installation Guide includes important safety-related information that must be followed to ensure the correct and safe use of the Rear Cover and the Unit. Prior to attaching this product, be sure to read both this guide and any related manuals thoroughly to understand the correct operation and functions of both the Rear Cover and the Unit.

■ Safety Icons

Throughout this manual the following icons are used to indicate procedures requiring special attention to safety.

These icons have the following meaning:

| | |
|--|---|
|  WARNING | Indicates situations where severe bodily injury, death or major machine damage can occur. |
|--|---|

| | |
|--|---|
|  CAUTION | Indicates situations where bodily injury or machine damage can occur. |
|--|---|

| | |
|--|--|
|  WARNING | |
| <ul style="list-style-type: none">• Installing the Rear Cover while power is supplied to the Unit may lead to an electric shock. Prior to installing the Rear Cover, confirm that the Unit's power supply is disconnected.• Prior to installing the Rear Cover, carefully read Section 3. Installation. | |

■ To Prevent Unit Failure

- Since the Unit is a precision device, do not subject it to shocks or excessive vibration.
- Be sure that no water, liquid or metal particles are adhering to the Unit, since they can cause unit failure or an electric shock.
- Do not operate or store the Unit in locations exposed to direct sunlight, high temperatures or dust.
- Do not operate or store the Unit in locations where vaporized chemicals are present in the air, or where chemicals may contact the unit.
- Do not attempt to open or modify the Unit.
- Do not use the Unit where corrosive gasses are present.

Package Contents

The Rear Cover's package includes the following items. Prior to using the unit, be sure to check that all the items are included in the package.

Rear Cover (Model No. CA1-RCVLRG-01)

■ Rear Cover : 1

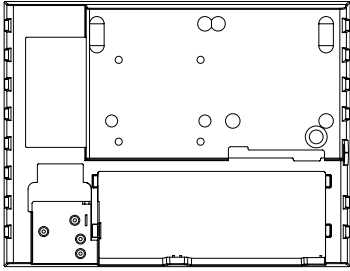

■ Installation Guide : 1

<This Guide>

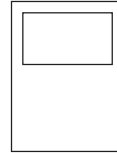

■ Bracket : 1

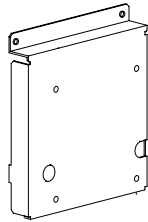

■ Bracket Attachment Screws : 4



■ Power Terminal Cover : 1

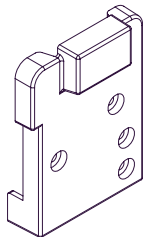

■ Power Terminal Cover

Attachment Screws (Black) : 4



Pro-face has thoroughly inspected this package's contents and quality prior to shipping. If, however, any of the items listed here is broken or missing, or you have any comments regarding the product, immediately contact your local Pro-face distributor.

Options

Desktop Stand (Model No. CA1-STDLRG-01)

- Desktop Stand : 1

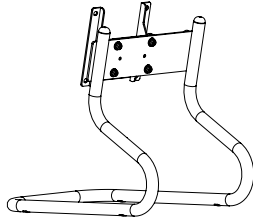

- Display Attachment Screws : 4

Wall Mount Adaptor (Model No. CA1-WMALRG-01)

- Unit Rear Face Plate : 1

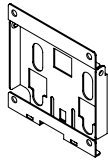

- Wall Mount Adaptor Plate : 1

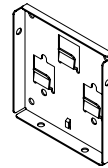

- Unit Rear Face Attachment

Screws: 4

- Wall Mount Adaptor

Attachment Screws: 2

- Installation Guide : 1

Rear Cover

The Rear Cover can be used in combination with the separately sold Desktop Stand, the Wall Mount Adaptor, or a commercially available arm. The combinations are shown below.

- Desk Mount
requires Rear Cover (CA1-RCVLRG-01) and Desktop Stand (CA1-STDLRG-01)
- Wall Mount
requires Rear Cover (CA1-RCVLRG-01) and Wall Mount Adaptor (CA1-WMALRG-01)
- Arm Mount
requires Rear Cover (CA1-RCVLRG-01) and commercially available VESA FPMPI compliant arm.

The Rear Cover can be connected with a commercially available VESA FPMPI compliant arm type fixture or wall mount fixture. (Arm mounting plate dimensions: 75mm x 75mm)



VESA: Video Electronics Standard Association

FPMPI: Flat Panel Monitor Physical Mounting Interface

(Specifications for attaching a liquid crystal display or similar device to a VESA compliant arm or stand stipulated)

1 External Dimensions

■ Rear Cover

The following drawings show the Unit's external dimensions with the Rear Cover attached.

For the external dimensions of the Rear Cover, refer to “2. Specifications”.

Unit: mm [in.]

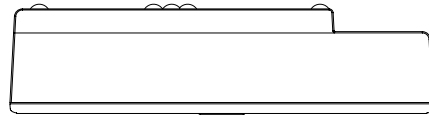

Top

317[12.48]

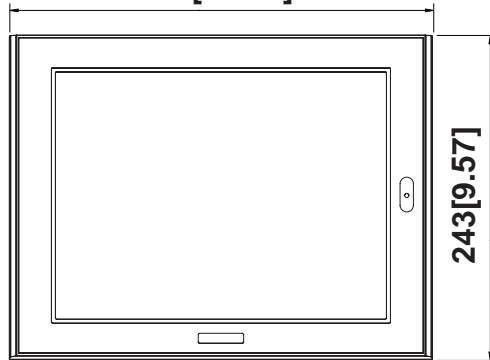

243[9.57]

Front

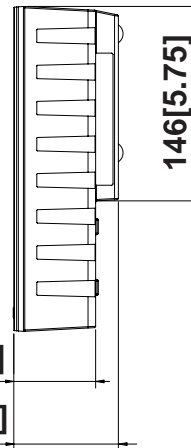

146[5.75]

62[2.44]

79[3.11]

Side

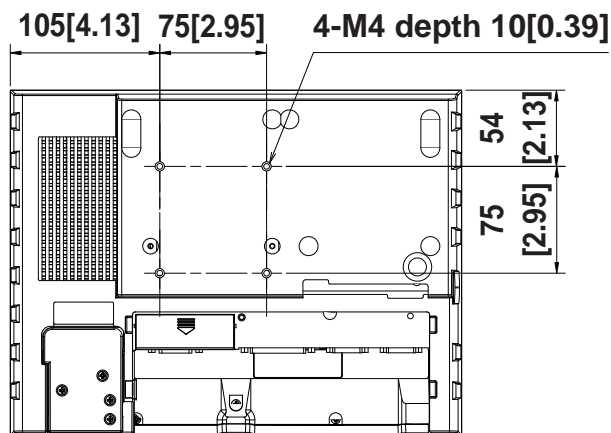

Rear

(Excluding projections)

■ Desktop Stand

The following drawings show the Unit's external dimensions with the Rear Cover and Desktop Stand attached.

For the external dimensions of the Desktop Stand, refer to “2. Specifications”.

Unit: mm [in.]

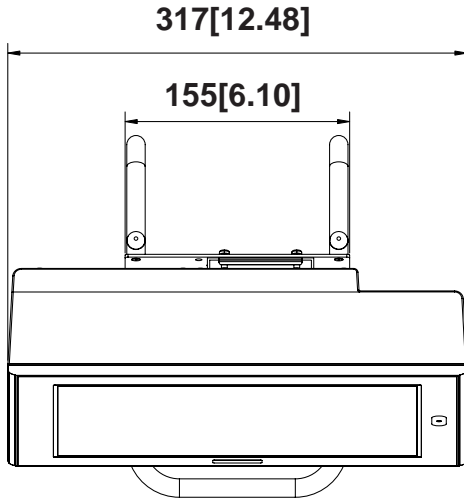

Top

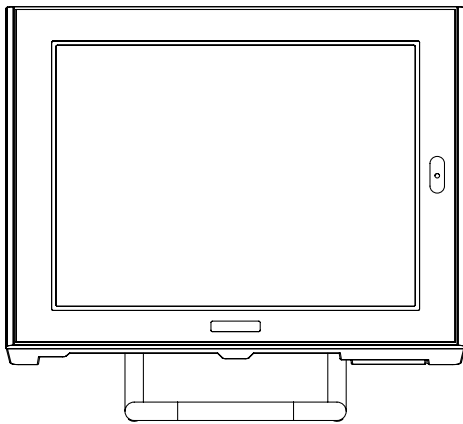

Front

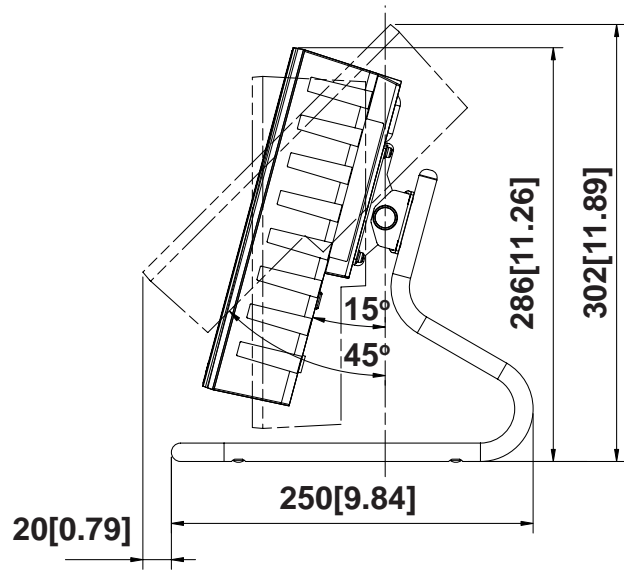

Side

(Excluding projections)

2 Specifications

■ Environmental

| | |
|-------------------------------|--|
| Ambient Operating Temperature | 0°C to 40°C |
| Storage Temperature | -10°C to +60°C |
| Ambient Humidity | 10%RH to 90%RH (non-condensing) |
| Dust | 0.1 mg/m ³ or less |
| Atmosphere | Free of corrosive gasses |
| Vibration Resistance | <p>Conforms to IEC61131-2 (JIS B 3501)</p> <p>When intermittent vibration is present:</p> <p>10 Hz to 57 Hz 0.075 mm</p> <p>57 Hz to 150 Hz 9.8 m/s²</p> <p>When continuous vibration is present:</p> <p>10 Hz to 57 Hz 0.035 mm</p> <p>57 Hz to 150 Hz 4.9 m/s²</p> <p>10 times in X, Y, and Z directions (for 80 min.)</p> |



- ***The operating temperature range of the Unit is between 0°C and 40°C with the Cover attached. This range is narrower than the Unit's normal range.***
- ***The Unit's IP65f equivalent rating is unavailable when the Rear Cover is attached to the Unit.***
- ***Vibration Cautions:***
When the Rear Cover is attached to the Unit, the Unit may vibrate due to resonance phenomena, similar to other wall-mount or tilt-stand products. This may result in screen data being difficult to view or the touch panel being difficult to operate. Be sure to install the Unit away from vibration sources, or install vibration absorbing materials.

■ Structural

| | |
|---------------------|---|
| External Dimensions | <p>Rear Cover : W317 [12.48] x H243 [9.57] x D71 [2.80] mm [in.]</p> <p>Desktop Stand : W155 [6.10] x H221 [8.70] x D250 [9.84] mm [in.]</p> <p>(Main unit only, excluding projections and connector)</p> |
| Weight | <p>Rear Cover : Approx. 0.6 kg [1.3 lb.]</p> <p>Desktop Stand : Approx. 0.8 kg [1.8 lb.]</p> |

3 Installation

You can use the Rear Cover in combination with the Desktop Stand, the Wall Mount Adaptor, or a commercially available arm. The installation procedures are described below.

- When attaching the Unit to the Desktop Stand
After attaching the Rear Cover to the Unit, attach the Desktop Stand to the Unit.
- When attaching the Unit to an Arm (Commercial Type)
After attaching the Rear Cover to the Unit, attach the Unit to the arm.



Note: For the procedures to install the Wall Mount Adaptor, refer to its “Wall Mount Adaptor Installation Guide”.



WARNING

- Installing the Rear Cover while power is supplied to the Unit may lead to an electric shock. Prior to installing the Rear Cover, confirm that the Unit's power supply is disconnected.
- Be sure to wear gloves, to prevent cuts or abrasions.

■ Attaching the Rear Cover

- 1) Remove the power supply terminal block plastic cover, installation gasket and I/F covers as shown below.

(The presence of each cover and the cover type depend on the Unit.)

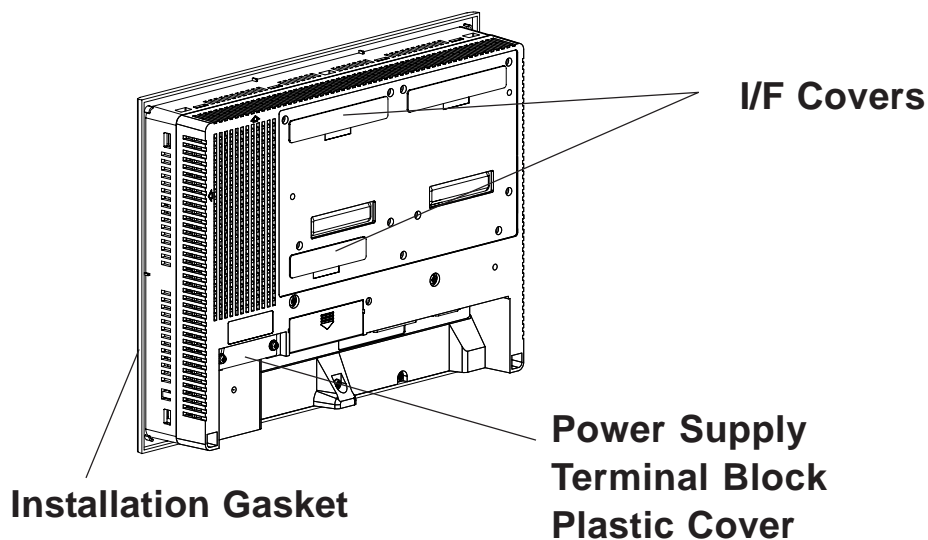

- 2) Attach the bracket as shown. The proper torque is 0.6 to 0.8 N•m. When attaching an expansion unit to EXT1, the bracket is not required.

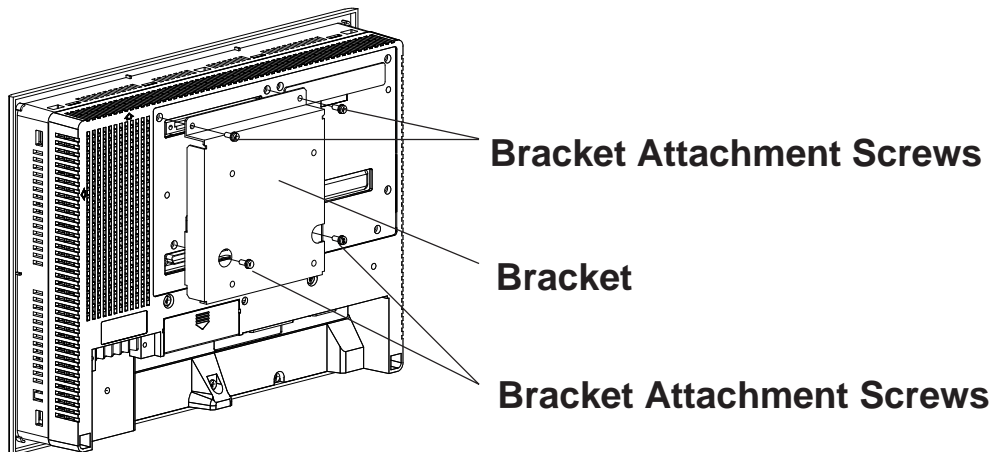

- 3) Place the Rear Cover on the rear of the Unit, and slowly push the Cover onto the Unit so that the Cover attachment clips catch on the upper and lower edges of the Unit.

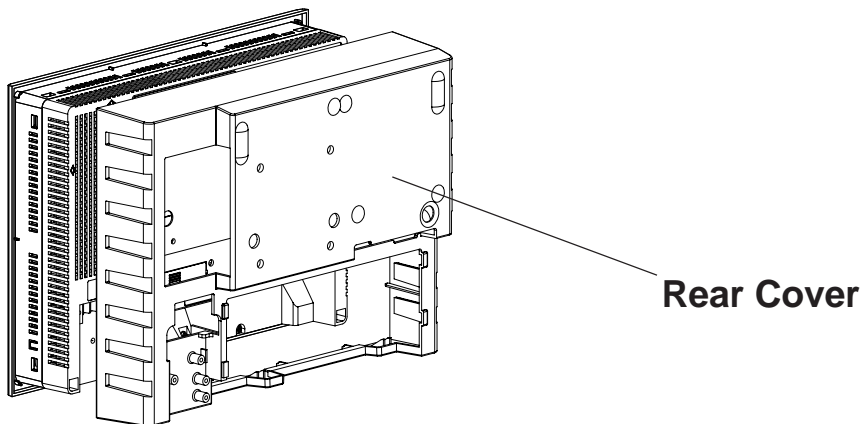

- 4) Connect the power supply terminals to the power supply terminal block. Route the cable as indicated by the arrows in the figure below.

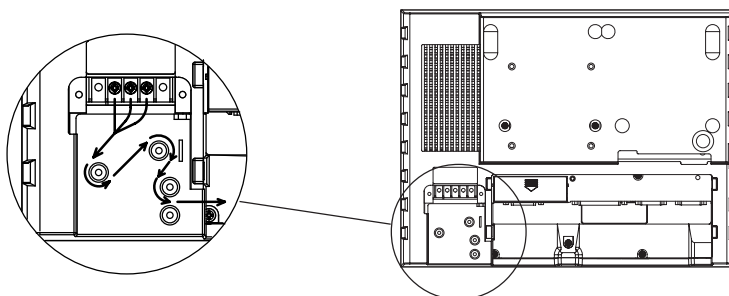

- 5) Attach the power terminal cover to the power supply terminal block, and secure it in place with the power terminal cover attachment screws. The proper torque is 0.5 to 0.6 N•m.



When attaching the power terminal cover, be careful not to pinch the power supply cable.

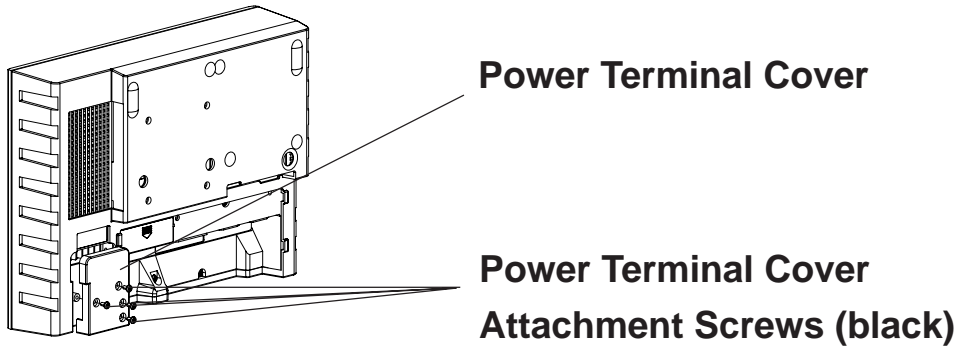

- 6) Connect all the cables according to the specifications of the Unit.



When attaching a keyboard or a similar device to the PS-600G, remove the sticker from the side face of the Rear Cover.

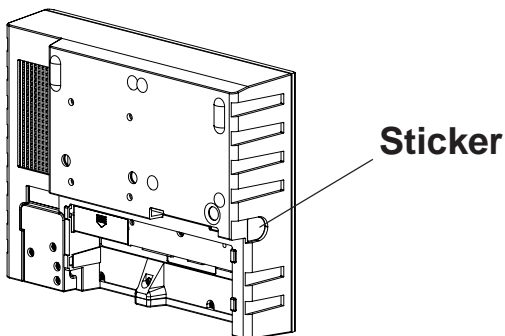

■ Attaching the Desktop Stand

- 1) As shown below, use the display attachment screws to attach the Desktop Stand to the Unit's Rear Cover. The proper torque is 0.6 to 0.8 N•m.

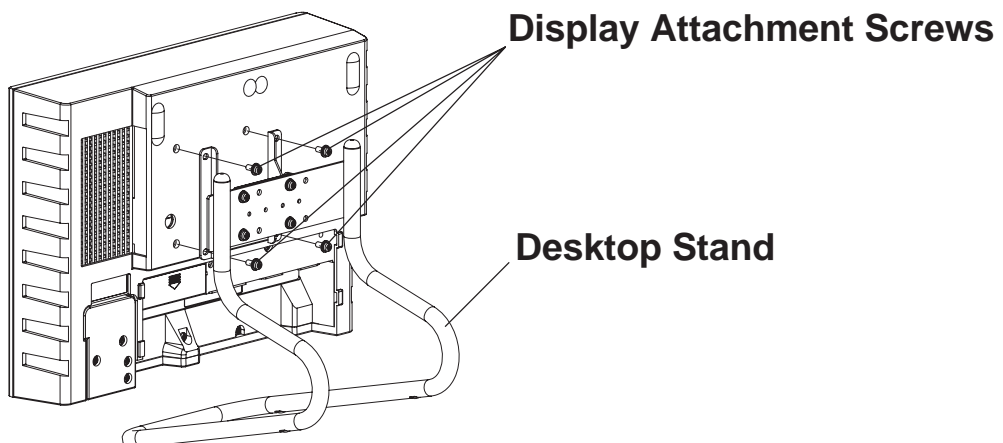

- 2) Adjust the screen angle.

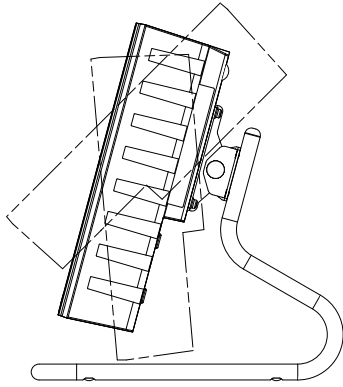

■ Attaching an Arm

A commercially available arm or similar device that conforms to VESA FPMPI standards can be connected with the Unit's Rear Cover.

Attach the Unit to the arm with the attachment screws.



The length of screws that can be used is limited.

With the Rear Cover, the screw depth is limited to 10 mm [0.39 in.] or less.

4 Cover Removal

Remove the Rear Cover from the Unit using the procedures described below.

- 1) Remove the power supply cover and disconnect all power cord terminals.
- 2) Use a slotted screwdriver to release the Rear Cover from the three clips on the bottom face of the Unit.

To do this, insert a standard screwdriver into the clip positions shown below, and lift up the Cover to release the Clip. Repeat for each clip.



Cover the tip of the slotted screwdriver with a cloth or paper to prevent the Unit's case from being damaged or scratched.

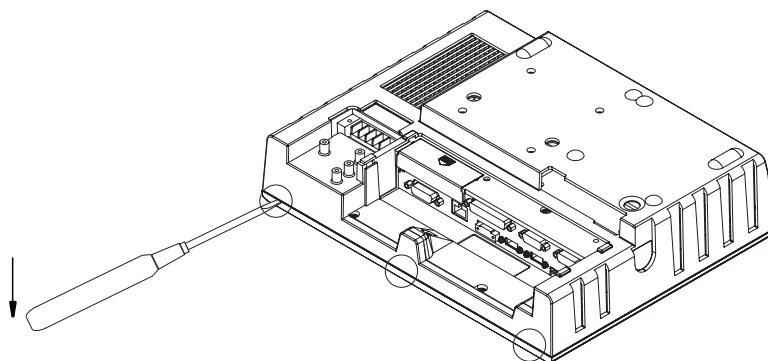

3) Release the Cover from the three top face clips in the same way.

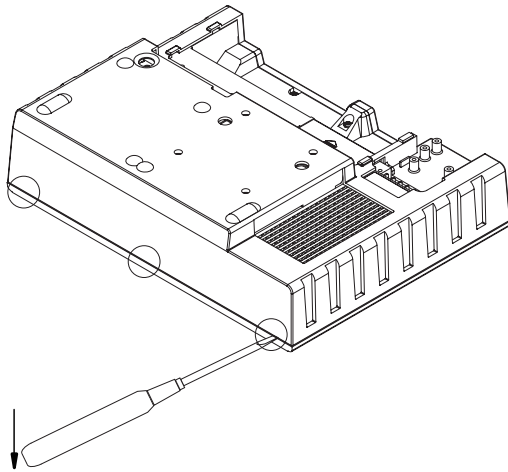

4) Slowly lift up the Cover to detach it from the Unit.

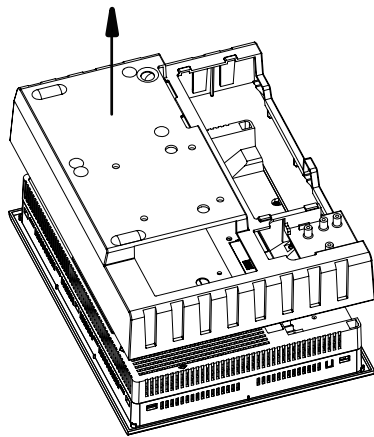

Note

Please be aware that Digital Electronics Corporation shall not be held liable by the user for any damages, losses, or third party claims arising from the uses of this product.

Digital Electronics Corporation

8-2-52 Nanko Higashi, Suminoe-ku, Osaka 559-0031, Japan

URL: <http://www.pro-face.com/>

© Copyright 2002 Digital Electronics Corporation. All rights reserved.

PFX102994L .CA1-RCVLRG-MT01E 2008.4. JM/A