

PREFACE

Thank you for purchasing the GP Screen Editor Software, "GP-PRO/PB III for Windows Ver. 5.0" for use with Digital's GP series programmable operator interfaces.

Please read this manual carefully in order to use this software properly, and be sure to keep this manual handy for future reference.

NOTES

- (1) The copyrights to all programs and manuals included in the GP-PRO/PB III for Windows Ver. 5.0 (hereinafter referred to as "this product") are reserved by the Digital Electronics Corporation. Digital grants the use of this product to its users as described in the "Software Operating Conditions" documentation, included with this product's CD-ROM. Any actions violating the above-mentioned conditions are prohibited by both Japanese and foreign regulations.
- (2) The contents of this manual have been thoroughly inspected. However, if you should find any errors or omissions in this manual, please inform your local GP representative of your findings.
- (3) Regardless of article (2), the Digital Electronics Corporation shall not be held responsible for any damages or third party claims resulting from the use of this product.
- (4) Differences may occur between the descriptions found in this manual and the actual functioning of this product. Therefore, the latest information on this product is provided in data files (i.e. Readme.txt files, etc.) and in separate documents. Please consult these sources as well as this manual prior to using the product.
- (5) Even though the information contained in and displayed by this product may be related to intangible or intellectual properties of the Digital Electronics Corporation or third parties, the Digital Electronics Corporation shall not warrant or grant the use of said properties to any users and/or other third parties.
- (6) The specifications set out in this manual are for overseas products only. As a result, some differences may exist between the specifications given here and for those of the identical Japanese product.

© Copyright 2001 Digital Electronics Corporation All rights reserved.
Digital Electronics Corporation, May 2001

Please refer to "Trademark Rights" for the rights to trademarks and trade names.

TRADEMARK RIGHTS

All company or product names used in this manual are trade names, trademarks (including registered trademarks), or service marks of their respective companies.

This product omits individual descriptions of each of these rights.

Trademark / Trade Name	Right Holder
Microsoft, MS, MS-DOS, Windows, Windows 95, Windows 98, Windows 2000, Windows NT, Windows Explorer, Microsoft Excel 95	Microsoft Corporation, USA
Intel, Pentium	Intel Corporation, USA
Pro-face	Digital Electronics Corporation (in Japan and other countries)
Ethernet	Western Digital Electric Corporation, USA
IBM, VGA, IBM Compatible	International Business Machines Corporation (IBM), USA

The following terms differ from the above mentioned formal trade names and trademarks.

Terms used in this manual	Formal Trade Name or Trademark
Windows 95	Microsoft® Windows®95 Operating System
Windows 98	Microsoft® Windows®98 Operating System
Windows 2000	Microsoft® Windows®2000 Operating System
Windows NT	Microsoft® Windows NT® Operating System
MS-DOS	Microsoft® MS-DOS® Operating System

HOW TO USE THIS MANUAL

■ Structure of this Manual

The "PLC Connection Manual" is the fourth of four volumes for this product, and explains how to use the "GP-PRO/PB III for Windows Ver. 5.0" software (hereinafter referred to as "this product"). Please refer to all of these manuals when using this product.

In addition to these manuals, data files containing supplemental information on updated functions are also provided.

To read these files, click on the [Start] button in your Windows OS main screen and select the [Programs]→[ProPB3Win] menu. Then click on the [Read Me] selection.

For detailed information about GP series products, please refer to each GP's "User's Manual". (Optionally available)

Vol. 1	Operation Manual	Describes this product's operation procedures and all standard functions. (provided as PDF data)
Vol. 2	Tag Reference Manual	Describes the function of and detailed settings for all GP-PRO/PBIII Tags. (provided as PDF data)
Vol. 3	Parts List	Describes this product's pre-made Parts and symbols. (provided as PDF data)
Vol. 4	PLC Connection Manual (this manual)	Describes the methods for connecting the GP to other, supported manufacturer PLCs. (provided as PDF data)

The PDF Manual CD-ROM also contains "Screen Data Layout Sheets" in Excel 95 format. To view this data, use your Excel program to open any of the files shown below.

These sheets are useful for designing tag address settings, etc. and example sheets are installed as part of the GP-PRO/PBIII for Windows standard installation.

The following two layout sheets, "Device Allocation Table" and "Tag Layout Sheet", are in Microsoft Excel 95 format and are located in the PDF Manual CD-ROM.

The following folder and file names are used.

Folder Name	File Name	Contents
propbwin/sheet	Device1E.xls	Device Allocation Table
	TAG1E.xls	Tag Layout Sheet
	TAG2E.xls	
	TAG3E.xls	
	TAG4E.xls	

For information on the use of Microsoft Excel, please refer to the Excel software's Users manual.

■ **GP/GLC Series Product Names** *1

The GP-PRO/PBIII functions and settings available will vary, depending on the model of GP used. Use the following table to identify your GP/GLC's model number.

◆ **GP Series**

	Series	Product Name	Model
GP 70 series	GP-H70 series	GP-H70L	GPH70-LG11-24V
			GPH70-LG41-24VP
		GP-H70S	GPH70-SC11-24V
			GPH70-SC41-24VP
	GP-270 series	GP-270L	GP270-LG11-24V
			GP270-LG21-24VP
			GP270-LG31-24V
		GP-270S	GP270-SC11-24V
			GP270-SC21-24VP
			GP270-SC31-24V
	GP-370 series	GP-370L	GP370-LG11-24V
			GP370-LG21-24VP
			GP370-LG31-24V
			GP370-LG41-24VP
		GP-370S	GP370-SC11-24V
			GP370-SC21-24VP
			GP370-SC31-24V
			GP370-SC41-24VP
	GP-470 series	GP-470E	GP470-EG11
			GP470-EG21-24VP
GP470-EG31-24V			
GP-570 series	GP-570S	GP570-SC11	
		GP570-SC21-24VP	
		GP570-SC31-24V	
	GP-570T	GP570-TC11	
		GP570-TC21-24VP	
		GP570-TC31-24V	
	GP-570L	GP570-LG21-24V	
		GP-570VM	GP570-TV11
	GP-571T	GP571-TC11	
GP-57JS		GP57J-SC11	
GP-675 series	GP-675T	GP675-TC11	
		GP675-TC41-24VP	
	GP-675S	GP675-SC11	
GP-870 series	GP-870VM	GP870-PV11	
GP77 series	GP-377 series	GP-377L	GP377-LG11-24V
			GP377-LG41-24V
	GP-377S	GP377-SC11-24V	
		GP377-SC41-24V	
GP-37W2 series	GP-37W2B	GP37W2-BG41-24V	

*1 For information about available models in your country, please contact your local distributor.

Series		Product Name	Model
GP77R series	GP-377R series	GP-377RT	GP377R-TC11-24V
			GP377R-TC41-24V
	GP-477R series	GP-477RE	GP477R-EG11
			GP477R-EG41-24VP
	GP-577R series	GP-577RT	GP577R-TC11
			GP577R-TC41-24VP
GP-577RS			GP577R-SC11
GP2000 series		GP-2400T	GP2400-TC41-24V
		GP-2500T	GP2500-TC11
			GP2500-TC41-24V
		GP-2501T	GP2501-TC11
		GP-2600T	GP2600-TC11
GP2600-TC11-24V			

◆ **GLC Series**

	Series	Product Name	Model
GLC series	GLC 100 series	GLC 100L	GLC100-LG41-24V
		GLC 100S	GLC100-SC41-24V
	GLC 300 series	GLC 300T	GLC300-TC41-24V
	GLC 400 series	GLC 2400T	GLC2400-TC41-24V

TABLE OF CONTENTS

PREFACE	i
Trademark Rights	ii
How to Use This Manual	iii
TABLE OF CONTENTS	vi
Manual Symbols and Terminology	xvii
Precautions	xx

CHAPTER 1 Direct Access Communication

1.1 Communication Method	1-1-1
1.1.1 System Area Start Address	1-1-2
1.1.2 LS Area Structure	1-1-3
1.1.3 About Each Address	1-1-4
1.1.4 Contents and Range of System Data Area	1-1-5
1.1.5 Special Relays	1-1-14
1.2 Efficient Data Communication	1-2-1
1.2.1 Block Transfer	1-2-1
1.2.2 LS Area Communication	1-2-2
1.2.3 Reset GP on Data Write Error	1-2-3
1.3 Connectable PLCs	1-3-1

CHAPTER 2 PLC-GP Connection

2.1 Mitsubishi Electric	2-1-1
2.1.1 System Structure	2-1-1
2.1.2 Cable Diagrams	2-1-11
2.1.3 Supported Devices	2-1-19
2.1.4 Environment Setup	2-1-29
2.1.5 2-Port Feature	2-1-35
2.2 Omron	2-2-1
2.2.1 System Structure	2-2-1
2.2.2 Cable Diagrams	2-2-5
2.2.3 Supported Devices	2-2-15
2.2.4 Environment Setup	2-2-19

2.3	Fuji Electric	2-3-1
2.3.1	System Structure	2-3-1
2.3.2	Cable Diagrams	2-3-3
2.3.3	Supported Devices	2-3-6
2.3.4	Environment Setup	2-3-9
2.4	Yaskawa Electric	2-4-1
2.4.1	System Structure	2-4-1
2.4.2	Cable Diagrams	2-4-5
2.4.3	Supported Devices	2-4-11
2.4.4	Environment Setup	2-4-18
2.5	Hitachi	2-5-1
2.5.1	System Structure	2-5-1
2.5.2	Cable Diagrams	2-5-4
2.5.3	Supported Devices	2-5-9
2.5.4	Environment Setup	2-5-17
2.6	Sharp	2-6-1
2.6.1	System Structure	2-6-1
2.6.2	Cable Diagrams	2-6-2
2.6.3	Supported Devices	2-6-7
2.6.4	Environment Setup	2-6-10
2.7	Matsushita Electric Works	2-7-1
2.7.1	System Structure	2-7-1
2.7.2	Cable Diagrams	2-7-2
2.7.3	Supported Devices	2-7-5
2.7.4	Environment Setup	2-7-7
2.8	Yokogawa Electric	2-8-1
2.8.1	System Structure	2-8-1
2.8.2	Cable Diagrams	2-8-4
2.8.3	Supported Devices	2-8-7
2.8.4	Environment Setup	2-8-13
2.9	Toyota Machine Works	2-9-1
2.9.1	System Structure	2-9-1
2.9.2	Cable Diagrams	2-9-3
2.9.3	Supported Devices	2-9-11
2.9.4	Environment Setup	2-9-15

2.10 Toshiba	2-10-1
2.10.1 System Structure	2-10-1
2.10.2 Cable Diagrams	2-10-2
2.10.3 Supported Devices	2-10-6
2.10.4 Environment Setup	2-10-8
2.11 Toshiba Machine	2-11-1
2.11.1 System Structure	2-11-1
2.11.2 Cable Diagrams	2-11-2
2.11.3 Supported Devices	2-11-3
2.11.4 Environment Setup	2-11-4
2.12 Koyo Electronics Industries	2-12-1
2.12.1 System Structure	2-12-1
2.12.2 Cable Diagrams	2-12-3
2.12.3 Supported Devices	2-12-7
2.12.4 Environment Setup	2-12-11
2.13 GE Fanuc Automation	2-13-1
2.13.1 System Structure	2-13-1
2.13.2 Cable Diagrams	2-13-4
2.13.3 Supported Devices	2-13-9
2.13.4 Environment Setup	2-13-12
2.14 Fanuc Motion Controller	2-14-1
2.14.1 System Structure	2-14-1
2.14.2 Cable Diagrams	2-14-2
2.14.3 Supported Devices	2-14-4
2.14.4 Environment Setup	2-14-5
2.15 IDEC	2-15-1
2.15.1 System Structure	2-15-1
2.15.2 Cable Diagrams	2-15-4
2.15.3 Supported Devices	2-15-13
2.15.4 Environment Setup	2-15-18
2.15.5 Error Codes	2-15-24
2.16 Siemens	2-16-1
2.16.1 System Structure	2-16-1
2.16.2 Cable Diagrams	2-16-4
2.16.3 Supported Devices	2-16-9
2.16.4 Environment Setup	2-16-15

- 2.17 Rockwell (Allen-Bradley) 2-17-1**
 - 2.17.1 System Structure 2-17-1
 - 2.17.2 Cable Diagrams 2-17-2
 - 2.17.3 Supported Devices 2-17-5
 - 2.17.4 Environment Setup 2-17-9
- 2.18 Keyence 2-18-1**
 - 2.18.1 System Structure 2-18-1
 - 2.18.2 Cable Diagrams 2-18-2
 - 2.18.3 Supported Devices 2-18-4
 - 2.18.4 Environment Setup 2-18-7
- 2.19 Shinko Electric 2-19-1**
 - 2.19.1 System Structure 2-19-1
 - 2.19.2 Cable Diagrams 2-19-2
 - 2.19.3 Supported Devices 2-19-3
 - 2.19.4 Environment Setup 2-19-3
- 2.20 Matsushita Electric Industrial 2-20-1**
 - 2.20.1 System Structure 2-20-1
 - 2.20.2 Cable Diagrams 2-20-2
 - 2.20.3 Supported Devices 2-20-3
 - 2.20.4 Environment Setup 2-20-4
- 2.21 Modicon 2-21-1**
 - 2.21.1 System Structure 2-21-1
 - 2.21.2 Cable Diagrams 2-21-1
 - 2.21.3 Supported Devices 2-21-2
 - 2.21.4 Environment Setup 2-21-3
- 2.22 ORIM VEXTA 2-22-1**
 - 2.22.1 System Structure 2-22-1
 - 2.22.2 Cable Diagrams 2-22-1
 - 2.22.3 Supported Devices 2-22-2
 - 2.22.4 Environment Setup 2-22-3
- 2.23 FATEK 2-23-1**
 - 2.23.1 System Structure 2-23-1
 - 2.23.2 Cable Diagrams 2-23-1
 - 2.23.3 Supported Devices 2-23-2
 - 2.23.4 Environment Setup 2-23-3

CHAPTER 3 Memory Link Communication

3.1	Setting Up Memory Link Communication	3-1-1
3.1.1	System Area	3-1-2
3.1.2	Contents and Range of System Data Area	3-1-3
3.1.3	Special Relay	3-1-6
3.2	Cable Diagrams	3-2-1
3.2.1	RS-232C Communication	3-2-1
3.2.2	RS-422 Communication	3-2-2
3.3	Memory Link Command	3-3-1
3.3.1	Read Command	3-3-3
3.3.2	Reply Command	3-3-4
3.3.3	Write Command	3-3-5
3.4	Sample System	3-4-1

CHAPTER 4 n:1 (Multi-link)

4.1	n:1 About Multi-link	4-1-1
4.2	Connectable PLCs	4-2-1
4.3	Prior to RUN mode	4-3-1
4.4	PLC Scan Time	4-4-1
4.5	About PLC Monopolize	4-5-1
4.6	SYSTEM AREA SETUP	4-6-1
4.7	STATION SETUP	4-7-1
4.8	CUSTOMIZE SETUP	4-8-1

CHAPTER 5 PLC-GP Connection (Multi-link)

5.1	Mitsubishi Electric	5-1-1
5.1.1	System Structure	5-1-1
5.1.2	Cable Diagrams	5-1-4
5.1.3	Supported Devices	5-1-8
5.1.4	Environment Setup	5-1-14
5.2	OMRON	5-2-1
5.2.1	System Structure	5-2-1
5.2.2	Cable Diagrams	5-2-3
5.2.3	Supported Devices	5-2-12
5.2.4	Environment Setup	5-2-16

5.3 Hitachi	5-3-1
5.3.1 System Structure	5-3-1
5.3.2 Cable Diagrams	5-3-3
5.3.3 Supported Devices	5-3-6
5.3.4 Environment Setup	5-3-7
5.4 Matsushita Electric	5-4-1
5.4.1 System Structure	5-4-1
5.4.2 Cable Diagrams	5-4-2
5.4.3 Supported Devices	5-4-3
5.4.4 Environment Setup	5-4-4
5.5 Yokogawa Electric	5-5-1
5.5.1 System Structure	5-5-1
5.5.2 Cable Diagrams	5-5-2
5.5.3 Supported Devices	5-5-5
5.5.4 Environment Setup	5-5-8
5.6 Toshiba.....	5-6-1
5.6.2 Cable Diagrams	5-6-1
5.6.1 System Structure	5-6-1
5.6.3 Supported Devices	5-6-3
5.6.4 Environment Setup	5-6-3
5.7 Rockwell (Allen-Bradley)	5-7-1
5.7.1 System Structure	5-7-1
5.7.2 Cable Diagrams	5-7-1
5.7.3 Supported Devices	5-7-3
5.7.4 Environment Setup	5-7-5
5.8 Keyence.....	5-8-1
5.8.1 System Structure	5-8-1
5.8.2 Cable Diagrams	5-8-1
5.8.3 Supported Devices	5-8-4
5.8.4 Environment Setup	5-8-5
5.9 Yaskawa Electric	5-9-1
5.9.1 System Structure	5-9-1
5.9.2 Cable Diagrams	5-9-1
5.9.3 Supported Devices	5-9-3
5.9.4 Environment Setup	5-9-4

5.10 SHARP	5-10-1
5.10.1 System Structure	5-10-1
5.10.2 Cable Diagrams	5-10-2
5.10.3 Supported Devices	5-10-5
5.10.4 Environment Setup	5-10-6

CHAPTER 6 Special Connection

6.1 Connectable PLCs	6-1-1
6.2 Rockwell (Allen-Bradley)	6-2-1
6.2.1 System Structure	6-2-1
6.2.2 Cable Diagrams	6-2-3
6.2.3 Supported Devices	6-2-7
6.2.4 Environment Setup	6-2-11
6.3 Modicon	6-3-1
6.3.1 System Structure	6-3-1
6.3.2 Cable Diagrams	6-3-2
6.3.3 Supported Devices	6-3-3
6.3.4 Environment Setup	6-3-4

CHAPTER 7 Ethernet Connections

7.1 Connectable PLCs	7-1-1
7.2 Mitsubishi Electric	7-2-1
7.2.1 System Structure for Ethernet Connection	7-2-1
7.2.2 Supported Devices	7-2-4
7.2.3 Environment Setup	7-2-7
7.2.4 Error Code	7-2-14
7.3 TOSHIBA	7-3-1
7.3.1 System Structure for Ethernet Connection	7-3-1
7.3.2 Supported Devices	7-3-2
7.3.3 Environment Setup	7-3-4
7.4 Yokogawa Electric	7-4-1
7.4.1 System Structure for Ethernet Connection	7-4-1
7.4.2 Supported Devices	7-4-2
7.4.3 Environment Setup	7-4-4

7.5 Omron	7-4-1
7.5.1 System Structure for Ethernet Connection	7-4-1
7.5.2 Supported Devices	7-4-5
7.5.3 Environment Setup	7-4-8
7.5.4 Error Code	7-4-20
7.6 Protocol Stack Error Codes.....	7-5-1
7.6.1 Protocol Stack Error Codes	7-5-1

CHAPTER 8 Profibus-DP

8.1 Connectable PLCs	8-1-1
8.2 Profibus-DP	8-2-1
8.2.1 System Structure for Profibus-DP Connection	8-2-1
8.2.2 Data Transfer with GP via Profibus-DP	8-2-3
8.2.3 Cable Diagram.....	8-2-5
8.2.4 Supported Devices.....	8-2-6
8.2.5 Environment Setup	8-2-8
8.2.6 Profibus Specific Error Codes	8-2-9

CHAPTER 9 CC-Link

9.1 Connectable PLCs	9-1-1
9.2 Remote Device Station	9-2-1
9.2.1 System Structure	9-2-1
9.2.2 Cable Diagram.....	9-2-2
9.2.3 Environment Settings	9-2-3
9.2.4 Monitoring Specifications	9-2-5
9.2.4.1 Overview	9-2-5
9.2.4.2 Ordinary Monitoring	9-2-12
9.2.4.3 Command Monitoring	9-2-14
9.2.5 Occupied Node	9-2-23
9.2.6 Error Code	9-2-26
9.3 Intelligent Device Station.....	9-3-1
9.3.1 System Configuration.....	9-3-1
9.3.2 Cable Diagram.....	9-3-4
9.3.3 Supported Devices.....	9-3-5
9.3.4 Environment Setup	9-3-14
9.3.5 Error Codes	9-3-18

CHAPTER 10 Device Net

10.1 Connectable PLCs	10-1-1
10.2 Slave I/O	10-2-1
10.2.1 System Structure for Device Net Connection	10-2-1
10.2.2 Cable Diagram	10-2-2
10.2.3 Environment Setup	10-2-3
10.2.4 Supported Devices	10-2-5
10.2.5 Error Codes	10-2-6

CHAPTER 11 Interbus

11.1 Connectable PLCs	11-1-1
11.2 Slave I/O	11-2-1
11.2.1 System Structure	11-2-1
11.2.2 Cable Diagrams	11-2-5
11.2.3 Supported Devices	11-2-6
11.2.4 Environment Setup	11-2-7
11.2.5 Interbus Specific Error Code	11-2-8

CHAPTER 12 Indicating Controllers

12.1 Connectable Controllers	12-1-1
12.2 Yokogawa Electric/Yokogawa M&C Controllers.....	12-2-1
12.2.1 System Structure	12-2-1
12.2.2 Cable Diagrams	12-2-2
12.2.3 Supported Devices	12-2-5
12.2.4 Environment Setup	12-2-7
12.3 Yamatake Controllers	12-3-1
12.3.1 System Structure	12-3-1
12.3.2 Cable Diagrams	12-3-3
12.3.3 Supported Devices	12-3-10
12.3.4 Environment Setup	12-3-12
12.4 RKC INSTRUMENT INC. Controllers	12-4-1
12.4.1 System Structure	12-4-1
12.4.2 Cable Diagrams	12-4-3
12.4.3 Supported Devices	12-4-8
12.4.4 Environment Setup	12-4-9

12.5 Omron Corporation Controllers	12-5-1
12.5.1 System Structure	12-5-1
12.5.2 Cable Diagrams	12-5-3
12.5.3 Supported Devices	12-5-7
12.5.4 Environment Setup	12-5-11
12.6 Shinko Technos Corporation Controllers	12-6-1
12.6.1 System Structure	12-6-1
12.6.2 Cable Diagrams	12-6-4
12.6.3 Supported Devices	12-6-8
12.6.4 Environment Setup	12-6-16
12.6.5 Error Code	12-6-17
12.7 Fuji Electronic Corporation Controllers	12-7-1
12.7.1 System Structure	12-7-1
12.7.2 Cable Diagrams	12-7-2
12.7.3 Supported Devices	12-7-5
12.7.4 Environment Setup	12-7-8
12.7.5 Error Code	12-7-9
12.8 Toho Electronics Inc. Controllers	12-6-1
12.8.1 System Structure	12-6-1
12.8.2 Cable Diagrams	12-6-5
12.8.3 Supported Devices	12-6-9
12.8.4 Environment Setup	12-6-22
12.8.5 Error Code	12-6-23

CHAPTER 13 Inverters

13.1 List of Connectable Inverters	13-1-1
13.2 Mitsubishi Electric Inverters	13-2-1
13.2.1 System Structure	13-2-1
13.2.2 Cable Diagrams	13-2-4
13.2.3 Supported Devices	13-2-6
13.2.4 Environment Setup	13-2-9
13.2.5 Error Codes	13-2-10

13.3 Fuji Electric Inverters	13-3-1
13.3.1 System Structure	13-3-1
13.3.2 Cable Diagrams	13-3-3
13.3.3 Supported Devices	13-3-7
13.3.4 Environment Setup	13-3-9
13.3.5 Error Codes	13-3-10

CHAPTER 14 Connecting to the GP-H70

14.1 Connecting a GP-H70 Series Unit	14-1-1
14.2 System Design	14-2-1
14.3 Cable Diagrams	14-3-1

A1 Maximum Number of Consecutive PLC Addresses

A1.1 Maximum number of Consecutive PLC Addresses (by Maker) ..	Appendix1-1
---	--------------------

A 2 Device Codes and Address Codes

A 2.1 PLC Devices and Address Codes (by Maker)	Appendix2-2
---	--------------------

A 3 Device Monitor

A 3.1 Functions	Appendix3- 3
A 3.2 Screen Operation	Appendix3- 4
A 3.2.1 Starting Device Monitor	Appendix3- 4
A3.2.2 Monitor Menu	Appendix3- 5
A 3.2.3 Writing Data	Appendix3- 17

MANUAL SYMBOLS AND TERMINOLOGY





This manual uses the following symbols and terminology.

If you have any questions about the contents of this manual, please contact your local GP distributor.

Also, if you have any question about your personal computer or Windows, please contact your PC distributor or manufacturer.



■ Safety Symbols and Terms

This manual uses the following symbols and terms to identify important information related to the correct and safe operation of this product.

Symbol	Description
	Indicates a potentially hazardous situation that could result in serious injury or death.
	Indicates a potentially hazardous situation that could result in minor injury or equipment damage.
	Indicates a potentially damaging action or dangerous situation that could result in abnormal equipment operation or data loss.
	Indicates instructions or procedures that must be performed to ensure correct product use.
	Indicates instructions or procedures that must not be performed.

■ General Information Symbols and Terms

This manual uses the following symbols and terms for general information.

Symbol	Description
	Provides hints on correct product use, or supplementary information.
	Indicates an item's related information (manual name, page number).
IBM Compatible	Indicates a PC that can run the Windows® operating system.
PLC	Abbreviation for Programmable Logic Controller. Includes programmable logic controllers and sequencers.
GP	Generic name for the "GP Series" of programmable operator interface made by the Digital Electronics Corporation.
GLC	Generic name for the "GLC Series" of Graphic Logic Controller made by the Digital Electronics Corporation.

■ **Keyboard Compatibility List**

This manual uses the following symbols to indicate computer keyboard keys.

The key names used by your computer keyboard may differ. Please use the chart below for reference.

Type Symbol	PS/2 Compatible 101 Keyboard
Esc	Esc
Tab	Tab ⇄
Ctrl	Ctrl
Shift	↑ Shift
Alt	Alt
Delete	Delete
Back space	Backspace

■ **Typical User Configuration**

This manual's description of this software's operating procedures and features is based on the PC system configuration shown below.

If you use a different configuration, the PC and GP screens, as well as the names used for pre-made Parts may differ. In this case, please substitute the equivalent screen and part names of your system for those given in this manual.

Hardware/Software	Specification	Remarks
Personal Computer	IBM compatible machine	
Memory	32 MB	
Mouse	Windows 95 compatible mouse	
O/S	Windows 95/98/NT (4.0 or higher)	
Host PLC	Mitsubishi MELSEC AnA series (Link)	
GP	GP-477RE	
Connection between the GP and PC	RS-232C	GPW-CB02 cable from Digital Electronics Corporation

The meaning of symbols used in the section titled "Supported Devices" in Chapter 2 and Chapter 5 are described below.

	Setup the address as Octal
	Word address' bottom column bit can only be set to 0
	Word address can only be set to multiples of 16
	Word address can only be set to multiples of 16 + 1
	Word address can only be set to even numbers
	Word address can only be set to multiples of 8
	Bit setup possible. After the word address, set the bit position, from 0-15
	Bit setup possible. After the word address, set the bit position, from 0-F
	Bit setup possible. After the word address, set the bit position, from 0-7
	Bit setup possible. After the word address, set the bit position, from 0-31
	When using 2 words (32 bit data), the relationship between the top and bottom data is: <div style="display: flex; align-items: center; margin-left: 20px;"> <div style="margin-right: 5px;">0</div> <div style="border: 1px solid black; padding: 2px;">L (low pos.)</div> </div> <div style="display: flex; align-items: center; margin-left: 20px;"> <div style="margin-right: 5px;">1</div> <div style="border: 1px solid black; padding: 2px;">H (high pos.)</div> </div>
	When using 2 words (32 bit data), the relationship between the top and bottom data is: <div style="display: flex; align-items: center; margin-left: 20px;"> <div style="margin-right: 5px;">0</div> <div style="border: 1px solid black; padding: 2px;">H (high pos.)</div> </div> <div style="display: flex; align-items: center; margin-left: 20px;"> <div style="margin-right: 5px;">1</div> <div style="border: 1px solid black; padding: 2px;">L (low pos.)</div> </div>

The device ranges listed in the sections titled "Supported Devices" are the maximum setup ranges. The ranges may be smaller than illustrated, depending on your PLC type. For further details, refer to the corresponding PLC manual.

Setup the System Area in the devices that are shaded.

Reference *For information on System Area, refer to "1.1 Communication Method"*

PRECAUTIONS

■ CD-ROM and Floppy Disk Usage Precautions

To prevent CD-ROM and floppy disk damage or failure, be sure to observe the following guidelines:



- Turn your PC ON or OFF only after you remove CD-ROM disk or floppy disk from it's drive.



- Do not remove the CD-ROM from the CD-ROM drive while the CD-ROM drive operation lamp is lit.
- Do not touch the CD-ROM recording surface or the floppy disk's internal magnetic disk.
- Do not place CD-ROMs or floppy disks where they may be exposed to extremely high or low temperatures, high levels of humidity or dust.
- Do not place the floppy disks near any type of magnetic device (stereo speaker, television, etc.)

■ Product Usage Precautions

For safe and correct use of this product, be sure to observe the following guidelines:



- **Do not create touch panel switches that are used to either control or to ensure the safety of equipment and personnel (such as an emergency stop switch, etc.).**

- **Please separate your safety/protection system from the GP operation system to prevent the danger of personal injury or property damage in case the machine malfunctions or operates incorrectly, or an inadequate system program is used.**



- Be sure to quit this program before turning your PC's power switch OFF.
- After transferring screen data created with this program to the GP unit, do not then send the same screen data from the GP to a DOS version of this screen editor software (e.g. GP-PRO/PB III, GP-PRO III).
- Do not change the contents of this program's project files using the Text Editor software.
- Do not transfer screen data to a GP that does not support all the data's functions (i.e. Logging, Filing, etc.).

1 Direct Access Communication

The *Direct Access* (Programless) format, which does not burden the PLC with protocol programs, runs communication between the GP and PLC. This chapter describes Direct Access Communication.

1.1 Communication Method

Depending on the part or tag setup, the GP can easily specify the PLC device. By doing so, the GP automatically requests the data required for operations (System Data) and the screen display from the PLC. Then the GP, depending on the PLC response, changes its screen display corresponding to its animation settings. Plus, data can be sent to the PLC using GP touch key input.

With Direct Access communication, the GP is always the master in the communication link.

In Direct Access Communication, data required by the screen display is automatically sent and received from the GP. Therefore, a PLC program for screen display operations is not necessary, thereby simplifying installation of the graphical control panel.

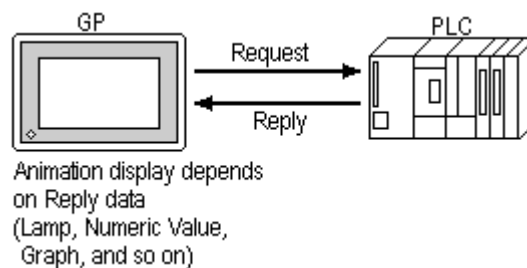

Caution

When an error occurs because data is read or written outside the PLC device range, the read/write operation continues retrying until the error is restored. For this reason, the action on the GP display screen may not seem to work. Check to make sure the device used for the part or tag is within the designated range for the PLC in use.

1.1.1 System Area Start Address

Setting up GP's INITIALIZE/STARTING ADDRESS OF SYSTEM DATA AREA automatically prepares the System Area in the PLC to make communication with the GP possible.

Reference For more information on setting starting address of System Data Area, refer to "PLC SETUP" in each GP unit's User's manual (sold separately).

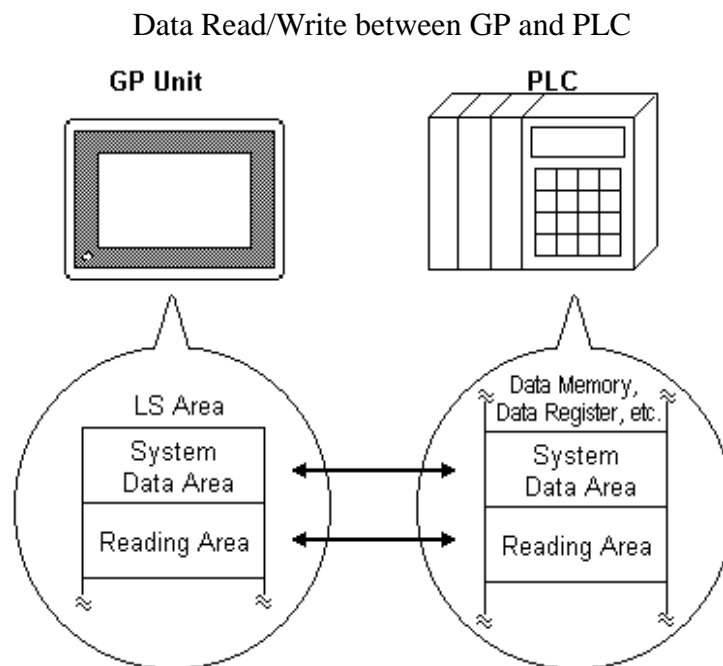

- Depending on the PLC, the System Data Area can be set to a certain device. In that device, only the addresses not used by the PLC can be used for the System Data Area.
- Devices that are highlighted with a double lined box in the device table described in Chapter 2 and Chapter 5 are the only device areas that can be used for the System Area.
- The starting address of the system data area can also be specified using the GP-PRO/PBIII software's "system settings" area.

Reference For more information, refer to the GP-PRO/PBIII for Windows Operation Manual's "Chapter 6 - GP Initial and System Settings" section.

1.1.2 LS Area Structure

The LS Area, located in the GP memory, is the area used for the GP's operations. The LS Area structure is as follows.

LS0	System Data Area
⋮	
LS19	Reading Area
LS20	
⋮	User Area
⋮	
LS2032	Special Relays
⋮	
LS2047	Reserved
LS2048	
⋮	User Area
LS2095	
LS2096	
⋮	
LS4095	

System Data Area This is the data write area for GP screen control data or error information necessary for operations.

Reading Area Stores data common to all screens, the block display data for trend graph, or video control data.*1 Up to 256 words can be designated here.

User Area The devices which are only for the GP's internal use, and cannot be allocated in the PLC. This area is used to process Parts and Tags which can only be processed by the GP internally and cannot be controlled by the PLC. This area can also store the video control data*1.



When using the Device Monitor feature, the User Area (LS2096 to LS4095) will be reserved and cannot be used.

Special Relays This area, during GP communications, is where the various status information is setup.



The following describes how to access the LS Area.

- Word Address access

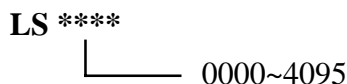

- Bit Address access

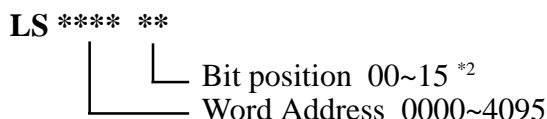

*1 When using the GP-570VM, be sure to set the video control area (22 words). The video control area is designated in either the reading area or the user's area.

Reference Each unit's User Manual (sold separately)

*2 When using Yaskawa Electronic CP9200SH Series protocol, Bit No. is from 0 to F.

Reserved Please do not use this area. It is only for GP's internal use. If you use this area, the GP will not operate properly.

1.1.3 About Each Address

Up to 20 words can be set as the System Data Area; up to 256 words can be set as the Reading Area.*1 The size of these determines each area's number of addresses.

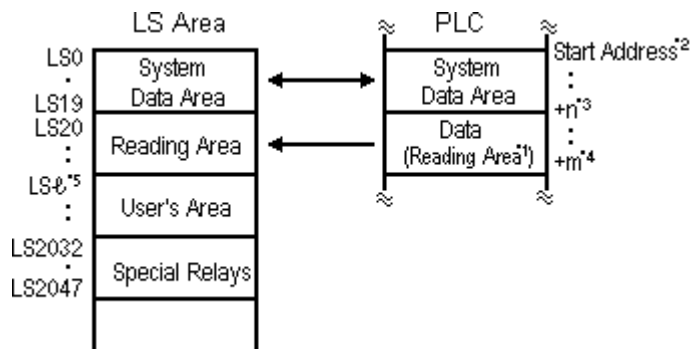

Part or Tag addresses cannot be set so that they include the System Area and the Reading Area, or the Reading Area and the User's Area.

When setting Parts or Tags inside the System Data Area's addresses, specify their data length as 16 bits.

*1 If the device range of your PLC is less than 256 words, the size of the PLC's device range minus the size of System Data Area gives the maximum size for the Reading Area.

*2 The Start Address means the start address of System Data Area specified in the INITIALIZE menu.

Reference For more information, refer to "5.5 PLC SETUP" in each unit's User's Manual (sold separately)

*3 $n = 0 \sim 19$: Differs with the number of items selected for the System Data Area in the INITIALIZE menu.

*4 $m =$ Reading Area Size

*5 $\text{⌘} =$ Reading Area Start Address (20) + Reading Area Size

1.1.4 Contents and Range of System Data Area

The following table describes the data write contents of the System Area for each address.

■ For a PLC using 16-bit addressing



- **If your PLC supports only 8-bit addresses, please refer to the table on page 1-8.**
- **When you wish to turn off the GP's display, use the display's ON/OFF bit (word address +9). Do not use the Control area's Backlight OFF bit (word address +14).**



- **The Word Address values assume that all the items have been selected for the System Data Area in the GP's INITIALIZE menu.**
- **Here, "item #" represents the item numbers shown in the System Environment Setup area's SYSTEM AREA SETUP; found in the GP OFFLINE mode's INITIALIZE area.**

	Item #	Word Addr	Contents	Bit	Detail
GP ↓ PLC E x c l u s i v e W r i t i n g A r e a	1	+0	Display Screen Number	1 to 8999 (However, 1 to 1999 when using BCD input)	
	2	+1	Error Status	0,1	Not used
			Each bit changes to reflect the GP error status. When an error occurs, the bit is set ON. A bit that has turned ON remains ON until the power is turned OFF and back ON, or until RUN mode is re-entered from OFFLINE mode. For Error Status data and processing notes, refer to the end of this section.	2	System ROM/RAM
				3	Memory Checksum
				4	SIO Framing
				5	SIO Parity
				6	SIO Over-run
				7,8	Not used
				9	Memory requires Initialization
				10	Timer Clock Error
	11	PLC			
	12 to 15	Not used			
	3	+2	Current YEAR, BCD 2 digits	Last two digits	
			+3	Current MONTH, BCD 2 digits	01 to 12 (month)
			+4	Current DAY, BCD 2 digits	01 to 31 (date)
			+5	Current TIME, BCD 4 digits	00 to 23 hr, 00 to 59 min
	4	+6	Status ^{*5}	0,1	Reserved
				2	Now Printing ^{*1}
				3	Writes a set value ^{*2}
				4 to 6	Reserved
7				PLC monopoly ^{*3}	
8				K-tag entry error ^{*4}	
9				Display 0: Possible, 1: Not Possible ^{*6}	
10 to 15	Reserved				
5	+7	Reserved			

	Item #	Word Addr	Contents	Bit	Detail					
PLC ↓ GP E x c l u s i v e R e a d i n g A r e a	6	+8	Change Screen Number	1 to 8999 (However, 1 to 1999 when using BCD input)						
	7	+9	Screen Display On/Off ^{*13}	FFFFh: Screen clears almost immediately. 0h: Screen turns ON. All other bits are reserved.						
	8	+10	+11	Clock's YEAR set value, BCD 2 digits (+flag)	Last 2 digits (bit #15 is the clock's data write change flag ^{*7})					
					+12	Clock's MONTH set value, BCD 2 digits	01 to 12			
							+13	Clock's DATE set value, BCD 2 digits	01 to 31	
									Clock's TIME set value, BCD 4 digits	00 to 23 Hr: 00 to 59 Min
	9	+14	Control ^{*14}	0	Backlight OFF ^{*8}					
				1	Buzzer ON					
				2	Starts printing					
				3	Reserved					
				4	Buzzer ^{*9} 0: Enabled, 1: Disabled					
				5	AUX Output ^{*9} 0: Enabled, 1: Disabled					
				6	Reserved					
				7	PLC monopoly ^{*10} 0: Disabled, 1: Enabled					
				8	VGA Display ^{*11} 0: Disabled, 1: Enabled					
				9,10	Reserved					
		11	Hard copy output ^{*12} 0: Enabled, 1: Disabled							
		12 to 15	Reserved							
	A	+15	Reserved	Set to 0						
	B	+16	Window Control ^{*15}	0	Display - 0: OFF, 1: ON					
				1	Changing the order of window overlapping 0: Possible, 1: Not Possible					
2 to 15				Reserved						
C	+17	Window Registration Number ^{*15}	Global Window registration number selected by Indirect setup (Bin/BCD)							
D	+18	Window Display Position (X coordinate data) ^{*15}	Global Window display coordinates selected by Indirect setup (Bin/BCD)							
	+19	Window Display Position (Y coordinate data) ^{*15}								

**1 This bit turns on during printing. Changing to OFFLINE mode while this bit is ON can scramble the print output.*

**2 Every time a value is written with the K-tag or Keypad Input Display, the bit is reversed.*

**3 When using Multi-link, the bit turns ON in the middle of PLC Monopolize.*

**4 When an alarm is setup in the middle of K-tag input, and a value outside the alarm range is entered, the bit turns ON. When you enter a value within the alarm range, or a screen change takes place, the bit turns OFF.*

*5 Monitor, in bit units, only the necessary bits. Since reserved bits may be used for GP system maintenance, etc., their ON/OFF status is not defined.

*6 Adding the screen display ON/OFF status

Adding the screen display ON/OFF bit to the system data area status allows you to detect the screen display OFF status based on the stand-by time period, on the PLC.

Add the screen display ON/OFF status bit to the system data area's Bit 9.

This bit will change in the following cases:

- (1) "FFFF" is written to the system data area's screen display ON/OFF bit (LS9 when using link type), to turn the screen display OFF. (Bit 9 = 1)
- (2) After the stand-by time has been elapsed, the screen display OFF bit is turned ON automatically. (Bit 9 = 1)
- (3) The screen display OFF status has been changed to the screen display ON status via screen switching, etc. (Bit 9 = 0)
- (4) The screen display ON/OFF status bit will not change via turning ON/OFF the system data area backlight OFF bit (Bit 0).

<System Data Area Status>

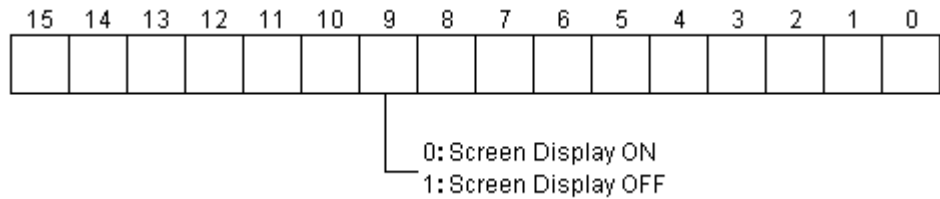

*7 When the data write flag changes (OFF—>ON, or ON—>OFF), the clock data is rewritten.

E.g. October 16, 1995, 9:57 pm

The current data in word address +10 is 0000.

Month, Date, Time data is written as follows:

- In word address +11 0010
- In word address +12 0016
- In word address +13 2157

When the YEAR's 15th bit is turned on, the data is written.

- Inputting 8095 into word address +10 causes the clock data to rewrite.

*8 With the GP series except GP-477R, GP-470 and GP870 series units, the backlight turns OFF when this bit is ON(LCD display does not change) and turns ON when the bit is OFF.

When the Backlight OFF bit (word address +14) turns ON, only the backlight will turn OFF, however, the LCD display will remain ON and all touch switches set up on the display can still be used. Use the Screen display ON/OFF bit (word address +9) to actually turn the screen display OFF.

*9 Control Bit 1(Buzzer On) is output as shown below.

Buzzer output..... When control bit 1 is ON, the GP internal buzzer is activated.

*10 When using n:1 (multi-link), PLC is monopolized when ON.

Reference Refer to **Chapter 4.5, "About PLC Monopolize."**

*11 For GP-570VM and GP-870VM, the entire screen becomes a VGA display. Touching any position on the screen in the middle of the display turns this OFF.

*12 Turning ON bit 11(Hard Copy Output) in the Control Area (word address +14) cancels the current printing of the display's hard copy.

- After printing is cancelled, bit 11, however, will not turn OFF automatically. Therefore, after checking the Status Area's Now Printing bit, turn OFF the Control Area's bit 11.

- When bit 11 in the Control Area is turned ON, hard copy cannot be created. If you cancel printing before it is completed, printing will stop after the last line of data on the panel's current display has been output. Data already input in the printer buffer's memory will not be deleted.

*13 After the screen display ON/OFF bit (word address +13) is set to OFF, simply touching the screen will turn the display ON again.

*14 Be sure to turn all reserved bits OFF since they may be used for GP system maintenance, etc.



When writing data to the Control Area (Address +14) be sure to use bit units. Writing data in Word units can cause values to change.

*15 **Reference** For more about windows, refer to "2.26 U-tag (Window Display)" in the Tag Reference Manual.

■ For a PLC using 8-bit addressing



- **The Byte Address values assume all the items have been selected for INITIALIZE's System Area.**
- **The High and Low positions of the Byte Address of all items vary among PLCs.**
- **Use the Screen Display ON/OFF bit (word address +22) to turn OFF the screen display. Do not use the Backlight OFF bit in the Control area (word address +34).**



Here, "item numbers" represent the item numbers shown in the [System Environment Setup] area's [SYSTEM AREA SETUP]; found in the GP OFFLINE mode's [INITIALIZE] area.

	Item #	Byte Addr	Contents	Bit	Detail	
GP ↓ PLC E x c l u s i v e W r i t i n g A r e a	1	+0	Display Screen Number	1 to 8999 (However, 1 to 1999 when using BCD input)		
		+1				
	2	+2	Error Status Each bit changes to reflect the GP error status. When an error occurs, the bit is set ON. A bit that has turned ON remains ON until the power is turned OFF and back ON, or until RUN mode is re-entered from OFFLINE mode.	0,1	Not used	
				2	System ROM/RAM	
				3	Memory Checksum	
				4	SIO Framing	
				5	SIO Parity	
				6	SIO Over-run	
		+3	For details and the handling process about the Error Status contents, refer to the end of this section.	7	Not used	
				0	Not used	
				1	Memory requires Initialization	
				2	Timer Clock Error	
	3			3	PLC SIO Error	
				4 to 7	Not used	
				+4	Current YEAR	Last 2 digits
				+5	BCD 2digits	
+6				Current MONTH	01 to 12 (month)	
+7				BCD 2digits		
+10				Current DAY	01 to 31 (date)	
+11	BCD 2digits					
+12	Current TIME	00 to 23 hr, 00 to 59 min				
+13	BCD 4digits					

	Item #	Byte Addr	Contents	Position	Bit	Detail						
GP ↓ PLC	4	+14	Status *5	Low	0,1	Reserved						
					2	Now Printing *1						
					3	K-tag write *2						
					4 to 6	Reserved						
					7	PLC Monopoly *3						
	High	0	K-tag entry error *4									
2 to 7		Reserved										
5	+16	Reserved										
	+17											
PLC ↓ GP E x c l u s i v e R e a d i n g A r e a	6	+20	Change Screen Number	1 to 8999 (However, 1 to 1999 when using BCD input)								
		+21										
	7	+22	Screen Display On/Off *14	FFFFh: Screen clears almost immediately. 0h: Screen turns ON. All other bits are reserved.								
		+23										
	8	+24	Clock's YEAR setup value BCD 2 digits (+flag)	Last 2 digits (15th bit of high address is the clock's data write change flag *6)								
		+25										
		+26						Clock's MONTH setup value BCD 2 digits	01 to 12			
		+27										
		+30						Clock's DATE setup value BCD 2 digits	01 to 31			
		+31										
	+32	Clock's TIME setup value BCD 4 digits	00 to 23 Hr: 00 to 59 Min									
	+33											
	9	+34			Low	0	Backlight OFF *7					
1						Buzzer ON						
2						Starts printing						
3						Reserved						
4						Buzzer *8 0: Enabled, 1: Disabled						
5						AUX Output *8 0: Enabled, 1: Disabled						
6						Reserved						
7		PLC Monopoly *9 0: Disabled, 1: Enabled										
High		0				VGA Display *10 0: Disabled, 1: Enabled						
		1 to 2				Reserved						
	3	Hard Copy output 0: Enabled, 1: Disabled										
	4 to 7	Reserved										
A	+36	Reserved				Set to 0						
	+37											

	Item #	Byte Addr	Contents	Position	Bit	Detail	
PLC ↓ GP E R e c e d i n g A r e a	B	+40	Window Control *11 *13	Low	0	Display 0: Possible, 1: Not Possible	
					1	Changing the order of window overlapping 0: Possible, 1: Not Possible	
		+41			High	2 to 15	Reserved
						High	2 to 15
	C	+42	Window Registration Number *11	Selected Global registration number for Indirect setup (Bin/BCD)			
		+43					
	D	+44	Window Display Position (X coordinate data) *11	Global Window display coordinates for Indirect setup (Bin/BCD)			
		+45					
		+46	Window Display Position (Y coordinate data) *11	Global Window display coordinates for Indirect setup (Bin/BCD)			
		+47					

*1 This bit turns ON during printing. Changing to OFFLINE mode while this bit is ON can scramble the print output.

*2 Every time a value is written with the K-tag, the bit is reversed.

*3 When using Multi-link, the bit turns on in the middle of PLC Monopolize.

*4 When an alarm is set up in the middle of K-tag input, and a value outside the alarm range is entered, the bit turns ON. When you enter a value within the alarm range, or a screen change takes place, the bit turns OFF.

*5 The vertical relationship of addresses differs depending on the PLC type.

Monitor, in bit units, only the necessary bits.

Since reserved bits may be used for GP system maintenance, etc., their ON/OFF status is not defined.

*6 When the data write flag changes (OFF→ON, or ON→OFF), the clock data is rewritten.

E.g. October 16, 1995, 9:57 pm

The current data in byte data addresses +24 and +25 is 0000.

Month, Date, Time byte data is written as follows:

- In byte addresses +26,27 0010
- In byte addresses +30,31 0016
- In byte addresses +32,33 2157

When the YEAR's 15th bit is turned on, the data is written.

- Inputting 8095 into byte addresses +24 and +25 causes the clock data to rewrite.

*7 For GP-675, GP-570, GP-577R, GP-370, GP-270, and GP-H70, the backlight turns OFF when this bit is ON. (LCD displays do not change.) Lights up when this bit turns OFF. When the Backlight OFF bit (byte address +34) turns ON, only the backlight will turn OFF, however, the LCD display will remain ON, and all touch switches set up on the display can still be operated. Use the Screen display ON/OFF bit (byte address +22) to turn OFF the screen display.

- *8 Control Bit 1(Buzzer On) is output as shown below.
 Buzzer output When control bit 1 is ON, the GP internal buzzer is activated.
 AUX output When control bit 1 is ON, the AUX buzzer is activated.
- *9 When using **n:1** (multi-link), PLC is monopolized when ON.
Reference Refer to **Chapter 4.5, "About PLC Monopolize."**
- *10 For GP-570VM, the entire screen becomes a VGA display. Pressing a free position on the screen in the middle of VGA display turns this OFF.
- *11 **Reference** For more about windows, refer to "**2.26 U-tag (Window Display)**" in the Tag Reference Manual.
- *12 The vertical relationship of addresses differs depending on the PLC type. Be sure to keep all Reserved bits turned OFF, since these bits may be needed for the GP system maintenance.
- *13 The vertical relationship of addresses differs depending on the PLC type.
- *14 After the screen display ON/OFF bit in byte address +22 is set to OFF, simply touching the screen will turn the display ON again.
- *15 Turning ON bit 3(Hard Copy Output) in the Control Area (byte address +35) cancels the current printing of the display's hard copy.
 - After printing is cancelled, bit 3, however, will not turn OFF automatically. Therefore, after checking the Status area's Now Printing bit, turn OFF Control area bit 3.
 - When bit 3 in the Control area is turned ON, hard copy cannot be created. If you cancel printing before it is completed, printing will stop after the last line of data on the panel's current display has been output. Data already input in the printer buffer's memory will not be deleted.

■ Error Status Contents and Correction Process

Error	Origin	Solution
System ROM/RAM	Problem with the hardware	Run Self-Diagnosis.
Memory Checksum	Because the screen file is corrupted, the screen memory data checksum does not match.	After powering up, check the screen where the error developed. (For details, refer to your Use's Manual, "Error Message" section.)
SIO Framing	Framing error	Check the SIO Setup. (For details, refer to you User's Manual, "Would Not Communicate" section.)
SIO Parity	Parity error	
SIO Over-run	Over-run error	
Memory requires Initialization	Internal Memory has not been initialized.	Initialize internal memory.
Timer clock Error	The GP internal clock has been interrupted.	The GP internal battery may be drained. Contact your local GP distributor for service.
PLC SIO Error (only for Direct Access type)	Either the SIO setup between the GP and PLC do not match, or an error has developed on the PLC side.	Check the SIO Setup. (For details, refer to you User's Manual, "Would Not Communicate" section.)

■ Printing out from the GP

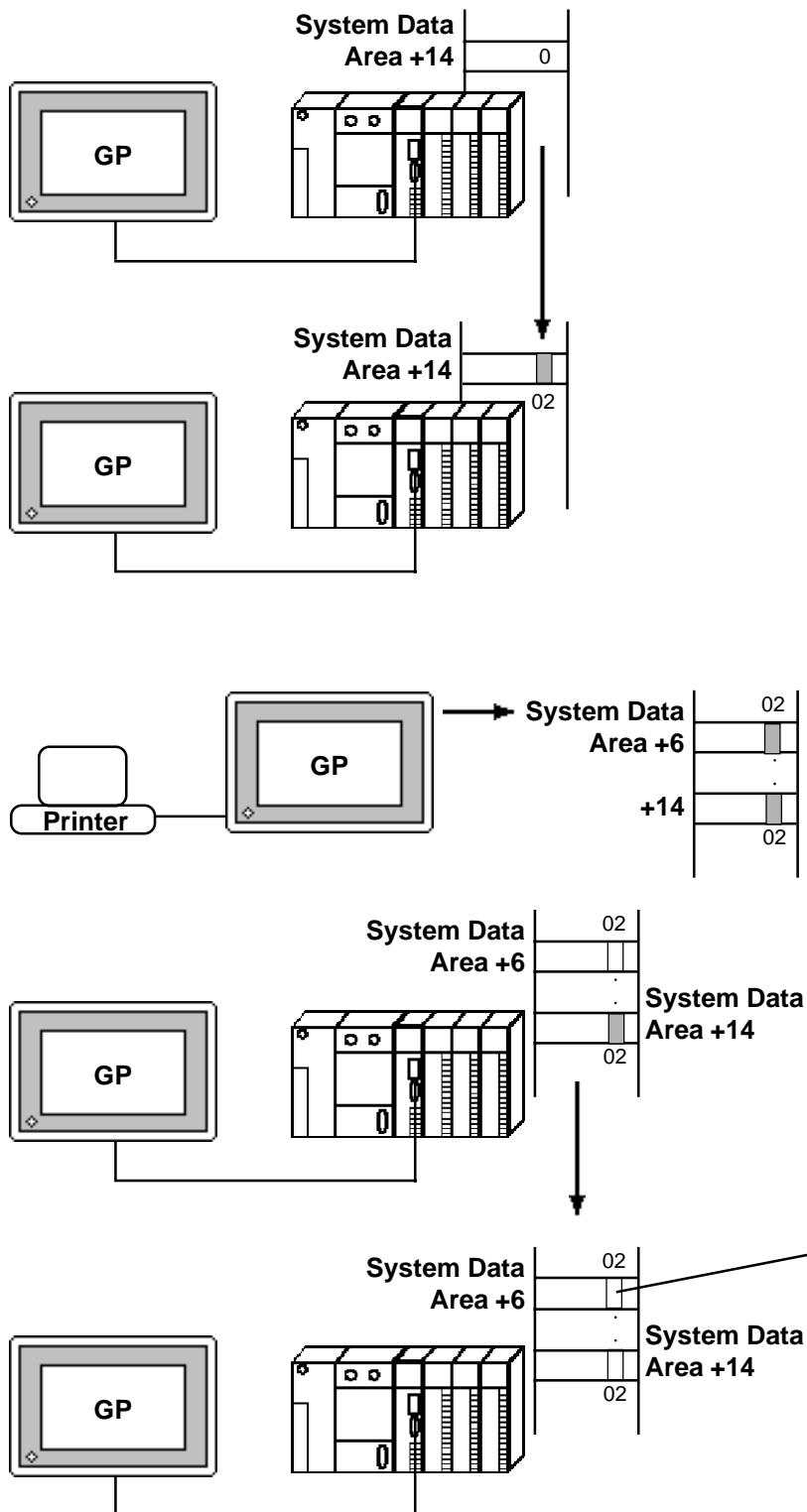

1) When the second bit in PLC System Data Area +14 is turned ON, (data 4) is written.

2) When the second bit in System Data Area +14 is turned ON, the on-screen data is output to the printer for (hard copy).

At the same time, the second bit in System Data Area +6 is turned ON.

3) After printing is finished, the second bit in System Data Area +6 turns OFF, however, the second bit in System Data Area +14 remains ON.

4) After checking the second bit in System Area +6 turned OFF, please turn OFF the second bit in System Area +14. Be sure to use the PLC to turn this bit OFF.

1.1.5 Special Relays

The structure of the GP-*70 Series' Special Relays is as follows.

LS2032	Common Relay Information	
LS2033	Base Screen Information	
LS2034	Reserved	
LS2035	1 Second Binary Counter	
LS2036	Tag Scan Time	
LS2037	SIO Cycle Time	
LS2038	Tag Scan Counter	
LS2039	SIO Error Code	
LS2040	max Token Circulation Speed	} Used only with n:1 multi-link connection
LS2041	current Token Circulation Speed	
LS2042	Reserved	
:		
:		
LS2047		

◆ **Common Relay Information (LS2032)**

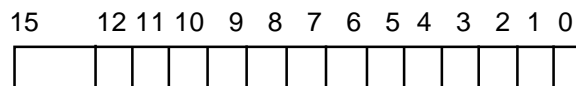

Bit	Contents
0	Repeatedly turns ON/OFF in a communication cycle.
1	Remains ON after when a screen change (base, window)occurs until the tag scan is complete.
2	ON only in the middle of an SIO error developing.
3	ON when displaying the Initial screen after powering up.
4	Always ON
5	Always OFF
6	Turns ON when backup SRAM data has been delated (Only for GP's equipped with backup SRAM).
7	Turns ON if a BCD error occurs while D script is being used. For more information about D script, refer to the Tag Reference Manual's section 3.1 "D script".
8	Turns ON if a zero division error occurs while D script is being used.
9	Filing data. Turns ON if the data is not transferred to Backup SRAM.
10	Filing data transfer is triggered by the Control Word Address. Turns ON if the data can not be transferred from PLC to SRAM. Also data transfer between PLCs is triggered by the Filing Data Display. Turns ON if the data is not transferred from PLC to SRAM only when the transfer complete bit address is used.
11	Filing data. Via transfer data to and from SRAM to LS area, via Filing Data Display.
12	When using D-script, turns ON if a communication error occurs when the function memcpy () is used, or reading the data from designated Address Offset. Turns OFF when data read is normally completed.
13-15	Reserved

Reference

For more information about D script, refer to Tag Reference Manual "3.1 D-Script/ Global D-Script".

◆ **Base Screen Information (LS2033)**

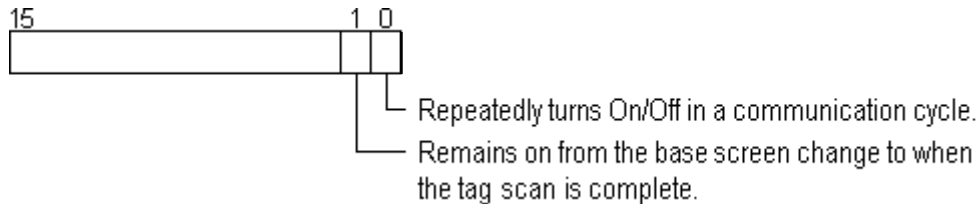

◆ **Reserved (LS2034)**

The *Reserved* area value is indeterminate. Do not use this area.

◆ **1 Second Binary Counter (LS2035)**

Begins counting in 1 second units, after powering up. The data is in binary format.

◆ **Tag Scan Time (LS2036)**

The time it takes to scan the setup screen display tags. The data is stored in binary *ms* units. The data renews at the point when the management of all the object tags is complete. The initial data value is **0**. The measured time may differ by ± 10 ms with the actual time.

◆ **SIO Cycle Time (LS2037)**

The time it takes in 1 cycle, from the beginning to the end, to scan the SIO object (PLC internal System Area) and various devices. The data renews at the point when the management of the System Area and all the object devices is complete. The initial data value is **0**. The unit is 10ms.

◆ **Tag Scan Counter (LS2038)**

Begins counting in binary units, roughly when the scan of the tags setup on the display screen is complete.

◆ **SIO Error Code (LS2039)**

When an SIO error arises, the SIO error code displayed last is stored in binary data.

◆ **Maximum Token Circulation Speed (LS2040)**

(only when using **n:1** Multi-link connection)

The maximum time it takes for the *token packet* (the right to communicate exclusively to the PLC) to circulate to the **n** number of connected GP's. The data is stored in binary *ms* units. The data renews when the maximum value changes or a screen change occurs. Its initial data value is **0**. The unit is 10ms.

◆ **Current Token Circulation Speed** (LS2041)

(only when using **n:1** Multi-link connection)

The current time it takes for the *token packet* (the right to communicate exclusively to the PLC) to circulate to the **n** number of connected GP's. The data is stored in binary *ms* units. The data renews when the current value changes or a screen change occurs. The initial data value is **0**. The unit is 10ms.



- ***If a problem occurs which causes an SIO error for an extended period of time, such as the unit's data transmission cable becomes loose or disconnected, etc., it may ultimately create a System Error. When this occurs, reset the GP.***
- ***When using the 1 Second Binary Counter and Tag Scan Counter value as the W-tag's monitor bit or D script's trigger bit, and the SIO error condition continues, it may develop into a System Error. When this occurs, reset the GP.***



Special Relays are not write protected. Be careful not to use a tag to overwrite this data.



When using a 1:1 connection, the initial Token Circulation Speed values remain (0).

1.2 Efficient Data Communication

When using the PLC Direct Access Type, the GP unit communicates based on the device addresses set on each screen. As a result, the more parts or tags set on a screen, the more data is transferred, reducing the communication speed. For this reason, to speed up the response times, make data communication as efficient as possible.

On the GP, in addition to the ordinary communication method, there are the *Block Transfer* and *LS Area Communication* methods, which upgrade data transfer efficiency.

1.2.1 Block Transfer

When displaying consecutive PLC devices on the GP, the GP automatically groups the transmission data into a block, which increases the communication speed.

The addresses in the determined data number range*¹ must be consecutive to use Data Block Transfer.

When parts or tags are set up in consecutive addresses, the GP automatically reads the data as a single block. When you wish to transfer a block, design your part or tag layout so that the addresses are consecutive.

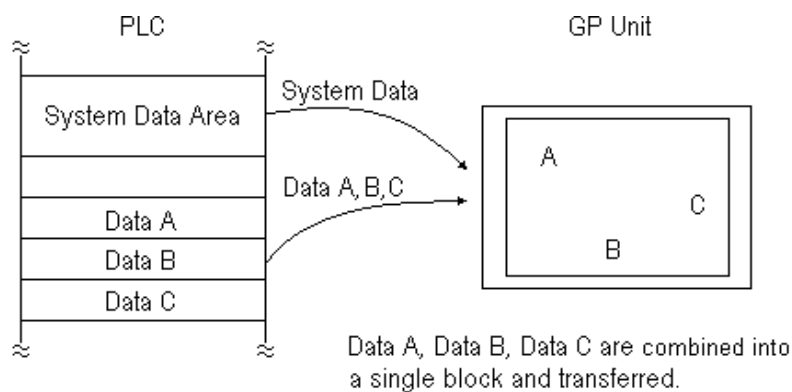

*1 The maximum number of consecutive addresses is limited by the PLC device. Refer to the Appendix, "Maximum Number of Consecutive Addresses".

1.2.2 LS Area Communication

Use the LS area for communication in the following cases: when there is display data common to all screens, when there is Trend Graph block display data, or when a video window display is used. (GP-570VM only)

To run LS Area communication, first set up the size of the Reading Area in GP's INITIALIZE setting. Then transfer the common display data or block display trend graph data to the Reading Area, allocated in the PLC's internal memory. (Transfer according to the PLC ladder program.)

By doing so, the data transferred into the Reading Area *and* the System Data is transmitted to the GP unit in one transmission.

By using the LS Area Communication method, no matter what screen is displayed on the GP, the System Data is transmitted continually. Therefore, to change screens quicker, use LS Area Communication instead of Block Transfer.

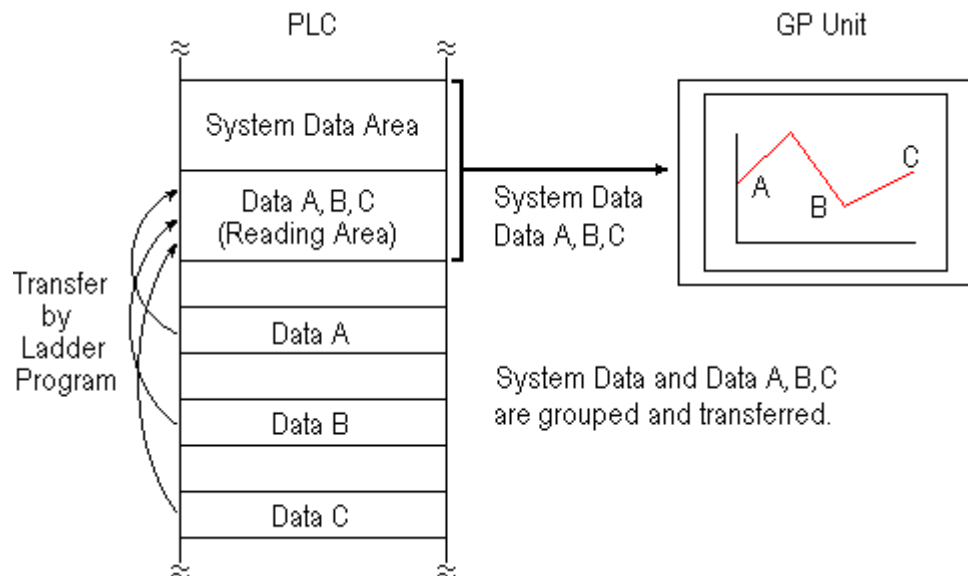

Important

- **Use LS Area transmission only when there is data common to all screens, when Trend Graph block display data is available, or when a video window display is being used. Otherwise, communication efficiency will not be realized.**
- **Setting up a Reading Area that is too large can cause the display of tags that do not use the Reading Area, or can slow data communication speed.**
- **When there are many parts or tags on a screen, set all the parts or tags to consecutive addresses. Block data transfer can be utilized as a result, speeding up transmission.**

1.2.3 Reset GP on Data Write Error

If a Write error occurs, you can cancel the error from the error display. You will need to set up this feature beforehand via the GP's OFFLINE mode's INITIALIZE area.

Reference Each GP User's Manual OFFLINE Mode



- This feature is available only with GP77R, GP-377, GP-2000 series units.
- The factory setting is OFF.

The following list shows the PLC types which do not support this feature.

SIEMENS	Profibus Interbus-S Slave
Allen-Bradley	PLC-5 DataHighway+ SLC500 DH485 Remote I/O
Modicon	Modibus Master Modibus Slave Modibus Plus
Device Net Slave I/O	
CC-Link	
Memory Link SIO	
Memory Link Ethernet	

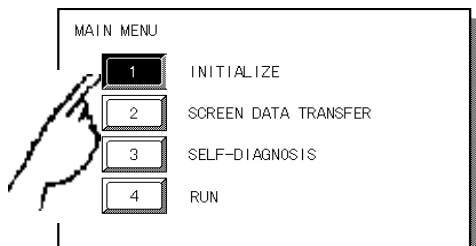

1) Touch item #1, INITIALIZE. The INITIALIZE menu will appear.

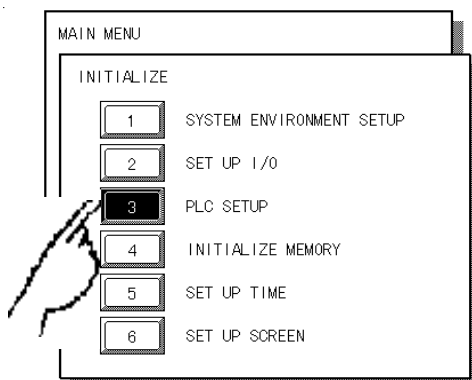

2) Touch item #3, PLC SETUP. The PLC SETUP menu appears.

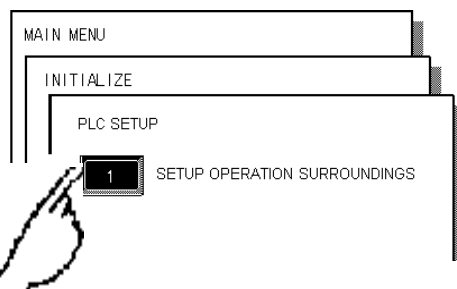

3) Touch item #1, SET UP OPERATION SURROUNDINGS. The SET UP OPERATION SURROUNDINGS menu will appear.

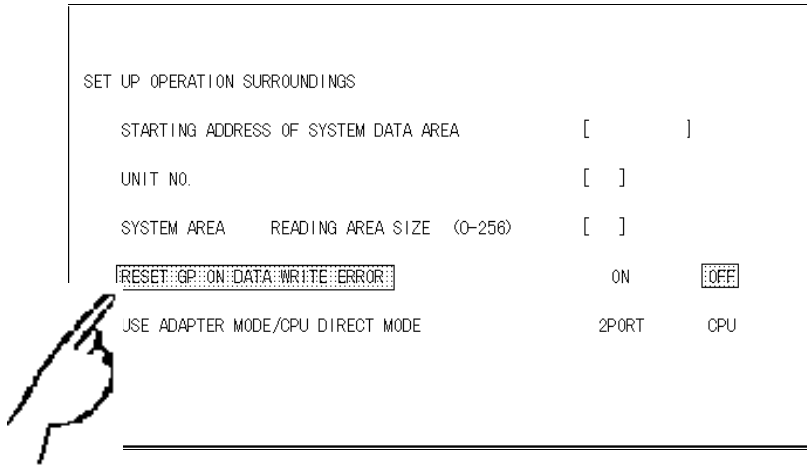

4) Touch the “RESET GP ON DATA WRITE ERROR” selection. The selected item is highlighted.



5) When DATA WRITE ERROR occurs, select ON to cancel the data write error.

When a DATA WRITE ERROR occurs, the screen shown here will be displayed.

*OFFLINE Mode **Reference**
GP User Manual OFFLINE Mode

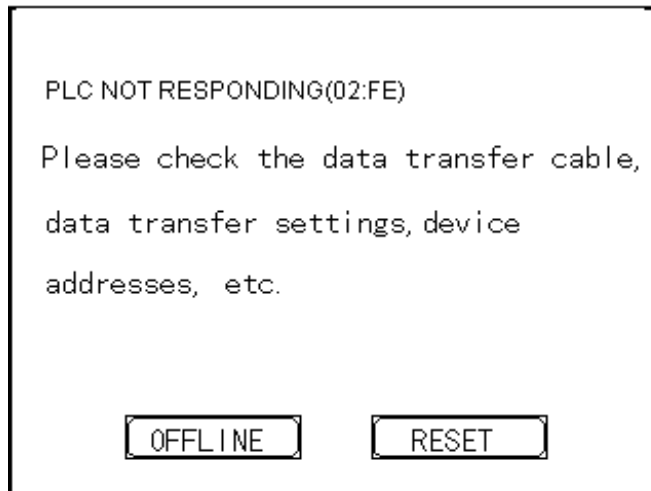

- If you select "OFFLINE" : The main menu will be displayed.
- If you select " RESET" : The GP will be reset, then change automatically to "OFFLINE" mode and a DATA WRITE ERROR will not occur.

1.3 Connectable PLCs

The following tables list the PLCs that can be connected and used with the GP.

Reference For more information on connectable PLC models that are also Multi-Link unit compatible, "4.2 Connectable PLCs".

Co.	Series Name	CPU	Link Unit	Comments	PLC name in PRO/PBIII	GP Series GLC 2400 Series	GLC 100 Series GLC 300 Series
M I T S U B I S H I	MELSEC-A	A2A, A3A , A4U	AJ71C24-S6 AJ71C24-S8 AJ71UC24		mitsubishi MELSEC-AnA (LINK)	○	○
			CPU Direct Connection	Can use the A-series exclusive Programming Console I/F cable (GP430-IP10-O). (Sold separately.)	mitsubishi MELSEC-AnA (CPU)	○	X
		A2U, A3U	AJ71C24-S6 AJ71C24-S8 AJ71UC24		mitsubishi MELSEC-AnA (LINK)	○	○
		A2U-S1, A3U, A2US-S1	CPU Direct Connection	Can use the A-series exclusive Programming Console I/F cable (GP430-IP10-O). (Sold separately.)	mitsubishi MELSEC-AnA (CPU)		
		A0J2, A0J2H	A0J2-C214-S1		mitsubishi MELSEC-AnN (LINK)		
		A0J2H	CPU Direct Connection	Can use the A-series exclusive Programming Console I/F cable (GP430-IP10-O). (Sold separately.)	mitsubishi MELSEC-AnN (CPU)		
		A1N, A2N, A3N	AJ71C24 AJ71C24-S3 AJ71C24-S6 AJ71C24-S8 AJ71UC24	The link unit, AJ71UC24 has been confirmed only with A2N CPU.	mitsubishi MELSEC-AnN (LINK)	○	X
			CPU Direct Connection	Can use the A-series exclusive Programming Console I/F cable (GP430-IP10-O). (Sold separately.)	mitsubishi MELSEC-AnN (CPU)		
		A3H, A2CJ-S3	CPU Direct Connection	Can use the A-series exclusive Programming Console I/F cable (GP430-IP10-O). (Sold separately.)	mitsubishi MELSEC-AnN (CPU)		
		A1S	A1SJ71C24-R2 A1SJ71UC24-R2 A1SJ71C24-R4		mitsubishi MELSEC-AnN (LINK)		
			CPU Direct Connection	Can use the A-series exclusive Programming Console I/F cable (GP430-IP10-O). (Sold separately.)	mitsubishi MELSEC-AnN (CPU)		
		A2US	A1SJ71C24-R2 A1SJ71UC24-R2 A1SJ71C24-R4		mitsubishi MELSEC-AnA (LINK)	○	○
			CPU Direct Connection	Can use the A-series exclusive Programming Console I/F cable (GP430-IP10-O). (Sold separately.)	mitsubishi MELSEC-AnA (CPU)	○	X

Co.	Series Name	CPU	Link Unit	Comments	PLC name in PRO/PBIII	GP Series GLC 2400 Series	GLC 100 Series GLC 300 Series		
MITSUBISHI	MELSEC-A	A1SJ, A2SH, A1SH	A1SJ71UC24-R4 A1SJ71UC24-R2		MITSUBISHI MELSEC-AnN (LINK)	○	x		
			CPU Direct Connection	Can use the A-series exclusive Programming Console I/F cable (GP430-IP10-O). (Sold separately.)	MITSUBISHI MELSEC-AnN (CPU)				
		A2USH-S1	A1SJ71UC24-R4 A1SJ71UC24-R2		MITSUBISHI MELSEC-AnA (LINK)			○	○
		CPU Direct Connection	Can use the A-series exclusive Programming Console I/F cable (GP430-IP10-O). (Sold separately.)	MITSUBISHI MELSEC-AnA (CPU)					
		A2CCPU24	Link I/F on CPU unit		MITSUBISHI MELSEC-AnN (LINK)				
				CPU Direct Connection	Can use the A-series exclusive Programming Console I/F cable (GP430-IP10-O). (Sold separately.)	MITSUBISHI MELSEC-AnN (CPU)			
	MELSEC-F ₂	F ₂ -20M, F ₂ -40M, F ₂ -60M	F ₂ -232GF		MITSUBISHI MELSEC-F ₂ series				
	MELSEC-FX	FX ₀ , FX ₁ , FX ₂ C, FX ₂ FX ₂ N-64MR FX ₂ NC-32MT FX ₀ N-60MR	CPU Direct Connection	* When using a RS-232C connection, an FX-232AW interface unit is necessary with the RS-232C/RS-422 adapter. * If you use the FX Series' exclusive Programing Console I/F Interface cable (GP430-IP11-O), you can connect directly to the CPU unit without having to use the adapter.	MITSUBISHI MELSEC-FX (CPU)	○	x		
		A1FX	CPU Direct Connection	You can use the A Series' exclusive Programing Console I/F Interface cable	MITSUBISHI MELSEC-AnN (CPU)				
		FX ₂ N	FX2N-232-BD FX2N-485-BD	PLC's system must be Ver.1.06 or later.	MITSUBISHI MELSEC-FX2 (LINK)				
	MELSEC-QnA	Q2A, Q2A-S1, Q4A	AJ71QC24 AJ71QC24-R4		MITSUBISHI MELSEC-QnA (LINK)	○	○		
			AJ71UC24	Usable devices are limited	MITSUBISHI MELSEC-AnA (LINK)				
		Q2AS Q2ASH	A1SJ71QC24		MITSUBISHI MELSEC-QnA (LINK)				
			A1SJ71UC24	Usable devices are limited	MITSUBISHI MELSEC-AnA (LINK)				

Co.	Series Name	CPU	Link Unit	Comments	PLC name in PRO/PBIII	GP Series GLC 2400 Series	GLC 100 Series GLC 300 Series		
M I T S U B I S H I	MELSEC-QnA	Q2AS-S1	A1SJ71QC24N		MITSUBISHI MELSEC-QnA (LINK)	○	○		
			A1SJ71UC24-R2 A1SJ71UC24-R4	Usable devices are limited	MITSUBISHI MELSEC-AnA (LINK)				
		Q2A Q4A Q2AS Q2AS-S1 Q4AR	CPU Direct Connection		Can use the A-series exclusive Programming Console I/F cable (GP430-IP10-O). (Sold separately.)	MITSUBISHI MELSEC-QnA (CPU)	○	X	
			Q4AR	AJ71QC24N		MITSUBISHI MELSEC-QnA (LINK)			
	MELSEC-Q	Q02CPU-A Q02HCPU-A Q06HCPU-A	A1SJ71UC24-R2 A1SJ7aUC24-R4		MITSUBISHI MELSEC-AnA (LINK)				
			CPU Direct Connection		MITSUBISHI MELSEC-AnA (CPU)				
		Q02CPU Q02HCPU Q06HCPU Q12HCPU Q25HCPU	QJ71C24 QJ71C24-R2		MITSUBISHI MELSEC-QnA (LINK)				
			CPU Direct Connection		Cannot connect to USB port on CPU unit.	MITSUBISHI MELSEC-Q (CPU)			
O M R O N	SYSMAC C	C500 C500F C1000H C1000HF C2000 C2000H	C500-LK201-V1 C500-LK203	C1000HF can only use C500-LK203 link unit.	OMRON SYSMAC-C series	○			○
			C200H C200HS	C200H-LK201 C200H-LK202					
		C20H C28H C40H C200HS CQM1-CPU42	Link I/F on CPU unit (RS-232C Port)						
		C120 C120F C200H C500 C500F C1000H C2000 C2000H C1000HF	C120-LK201-V1 C120-LK202-V1 C500-LK203						
		SRM1-CO2, CPM1-20CDR-A CPM2A	CPM1-CIF01 CPM1-CIF11						
		C200HS, SRM1-CO2, CQM1-CPU11, CQM1-CPU42, CPM1-20CDR-A CPM2A, CQM1H-CPU2I	CPU Direct Connection	Omron's isolation cable (CQM1-CIF01) is necessary.					
		CPM2C	CPU Direct Connection	Omron's isolation cable CS1W-CN114 and CQM1-CIF01 are necessary.					
			CPM2C-CIF01						

Co.	Series Name	CPU	Link Unit	Comments	PLC name in PRO/PBIII	GP Series GLC 2400 Series	GLC 100 Series GLC 300 Series	
O M R O N	SYSMAC-α	C200HX-CPU85-Z	C200HW-COM06	RS422 can use only the 4-wire type.	OMRON SYSMAC-C series	○	○	
		C200HX-CPU64	RS-232C Port on CPU unit					
		C200HX-CPU44						
		C200HE-CPU42						
		C200HG-CPU63						
		C200HG-CPU43						
		C200HE-CPU42-Z	C200H-LK202-V1					
		C200HX-CPU64-Z	C200H-LK201-V1					
	SYSMAC CV	CV500 CV1000 CVM1	Link I/F on CPU unit, CV500-LK201 (Host Link)	Tested with the CVM1-CPU01 for the CVM1 Series	OMRON SYSMAC-CV series	○	x	
	SYSMAC CS1	CS1H-CPU67 CS1H-CPU66 CS1H-CPU65 CS1H-CPU64 CS1H-CPU63 CS1G-CPU45 CS1G-CPU44	RS-232C Port on CPU unit Peripheral port on CPU unit CS1W-SCB21 CS1W-SCB41 CS1W-SCU21		OMRON SYSMAC-CS1 series			
F U J I	MICREX-F	F80H, F120H F250	FFU120B		FUJI MICREX-F series	○	x	
		F80H F120H F250 F30 F50 F60 F80 F81 F120 F120S F200	FFK100A-C10 FFK120A-C10	*When using FFK100A-C10, the ROM cassette FMC312A-T (PC exclusive) is necessary. *To use FFK120A-C10, use the command setup type synchronous nonprocedure mode 1. The ROM cassette is unnecessary.				
		F70S	NC1L-RS2	Tested with the NC1P-S0 CPU				
		F80H F250	CPU Direct Connection Use the loader port. T-link I/F unit	Use the PC loader adapter (FLT-ASFK) made by Fuji Electric. Refer to T-link I/F unit User's Manual				FUJI MICREX-F series (FLT) FUJI MICREX-F series (T-link)
		FLEX-PC	NB1, NB2, NB3 NJ NS NB1, NB2, NB3 NJ, NS	NB-RS1-AC NJ-RS2, NJ-RS4 NS-RS1 CPU Direct Connection		FUJI FLEX-PC series (Link) FUJI FLEX-PC (CPU)		
	Y A S K A W A	Memocon-SC	U84 U84J	JAMSC-C8110		YASKAWA Memocon SC series	○	x
			U84S	JAMSC-C8610				
GL40S			JAMSC-IF61 JAMSC-IF41A (extension)					
GL60S GL60H GL70H			JAMSC-IF60 JAMSC-IF61					
GL60S			JAMSC-IF612					
GL120			CPU Direct Connection					

Co.	Series Name	CPU	Link Unit	Comments	PLC name in PRO/PBIII	GP Series GLC 2400 Series	GLC 100 Series GLC 300 Series			
Y A S K A W A	MP900	MP930	MEMOBUS Port on CPU unit		YASKAWA CP9200SH series	○	x			
		MP920	MEMOBUS Port on CPU unit							
			JEPMC-CM200							
	Control Pack	CP-9200 CP-9200H	CPU Direct Connection		YASKAWA Memocon SC series					
		CP-9200SH	Link I/F on CPU unit		YASKAWA CP9200SH series					
	Memocon Micro	Micro	CPU Direct Connection		YASKAWA Memocon SC series					
PROGIC-8	PROGIC-8 PC01	Link I/F on CPU unit		YASKAWA PROGIC 8 series						
MEMCON-SC	GL120 GL130	JAMSC- 120MON27100		YASKAWA GL120/130 series						
H I T A C H I	HIDIC-S10 α	2 α 2 α E	Link I/F on CPU unit		HITACHI HIDIC-S10 α series	○	x			
		4 α 4 α F	LWE805							
		HIDIC H	H20 H28 H40 H64	CPU Direct Connection				Previously known as HIZAC H Series. Refer to Procedure 1 for data communication control.	HITACHI HIDIC-H series	
	H-200 H-300 H-302 H-700 H-702 H-2000 H-2002 H-252C H-4010 EH-150									
	H-300 H-700 H-2000 H-2002		COMM-H COMM-2H							
	H-302 H-702 H-4010		COMM-2H							
	EH-150 (EH-CPU448)		Serial Port 1 on CPU unit		Refer to Procedure 2 for data communication control.					HITACHI HIDIC-H2 series
	H-302 H-702 H-2002 H-4010		COMM-2H							
	HIZAC EC		EC-40HR		CPU Direct Connection					
	S10mini	LQP000 LQP010 LQP011	LQE060		HITACHI HIDIC-S10 α series					

Co.	Series Name	CPU	Link Unit	Comments	PLC name in PRO/PBIII	GP Series GLC 2400 Series	GLC 100 Series GLC 300 Series					
SHARP	New Satellite JW	JW20 JW70 JW100 JW-32CUH JW-32CUH1 JW-33CUH3	Link I/F on CPU unit (COMM Port)	CPU module equipped with a communication port is necessary. JW20, JW70, and JW100 is equipped as the standard for JW-22CU, JW-70CU, and JW-100CU.	SHARP New Satellite JW series							
		JW20 JW-32CUH JW-32CUH1 JW-33CUH3	JW-21CM									
		JW50 JW70 JW100	ZW-10CM, JW-10CM	JW-10CM tested only with 4-line.								
MATSUSHITA	MEWNET	FP3	AFP3462		MATSUSHITA MEWNET-FP series	○	x					
		FP5	AFP5462									
		FP10(S)	COM. Port on CPU unit AFP3462									
		FP1	RS-232C Port on CPU unit CPU Direct Connection	Tested using C24C and C40C.								
		FP-M	Serial port connector on Board CPU Direct Connection									
		FP10SH	COM.Port on CPU unit									
		FP2	COM.Port on CPU unit CPU Direct Connection									
		FP0	RS-232C Port on CPU unit CPU Direct connection	CPU unit built-in RS-232C is required.								
		YOKOGAWA	FACTORY ACE	FA500				LC01-0N LC02-0N	A-type CPU MP*0/AP*0 are not supported. Use together with B-type or higher. Can also use together with A-type CPU MP*1/AP*1.	YOKOGAWA FACTORY ACE ** 1:1 Comm.	○	○
				FA-M3				F3LC01-1N	Can communicate with F3SP10-0N CPU.			
F3LC11-1N F3LC11-2N F3LC11-1F												
CPU Direct Connection					○	x						

* 1 Previously titled "FA-500" software on the GP-PRO II and GP-PRO III software.

Co.	Series Name	CPU	Link Unit	Comments	PLC name in PRO/PBIII	GP Series GLC 2400 Series	GLC 100 Series GLC 300 Series
Y O K O G A W A	FACTORY ACE	FA500 (1:n connection)	LC02-0N	Instead of the FA500, the digital indication controller (UT37/38/2000) and the MR series recorder can be used in a multi-link connection, without programming.	YOKOGAWA FACTORY ACE *1 1:n Comm.		
		FA-M3 (1:n connection)	F3LC11-2N	Instead FA-M3, a digital indicating controller (UT37/ 38/ 2000) can be used with and recorder (mR Series) multi-link connections, without programming. Communication is tested with F3SP20-ON and F3SP35-5N CPUs.			
T O Y O T A	TOYOPUC-PC2	PC2, L2	TLU-2652		TOYOTA	○	○
		PC2J	THU-2755		TOYOPUC-PC2		
	TOYOPUC-PC3	PC2J (1:n connection)	THU-2755		TOYOTA TOYOPUC-PC2 1:n Comm.	○	x
		PC3J	Link I/F on CPU unit THU-2755		TOYOTA TOYOPUC-PC3J		
T O S H I B A	PROSEC EX	EX2000	Link I/F on CPU unit		TOSHIBA PROSEC -EX2000 series	○	x
	PROSEC T	T3,T3H, T2N,T2E	Link I/F on CPU unit		TOSHIBA PROSEC-T series		
	PROVISOR B	B200CH B200CUF B200CURM B200CUFRM	B2000LM		TOSHIBA MACHINE TC200 series		
A O C S H H I I N B E A	PROVISOR TC200	TCCUH	TCCMW TCCMO Link I/F on CPU unit	When connecting the GP and PLC directly, set the Unit No. in the SET UP OPERATION SURROUNDINGS menu to 64.	TOSHIBA MACHINE TC200 series	○	x

* 1 It was known as "FA-500M" software on GP-PRO II and GP-PRO III.

Co.	Series Name	CPU	Link Unit	Comments	PLC name in PRO/PBIII	GP Series GLC 2400 Series	GLC 100 Series GLC 300 Series	
K O Y O	KOSTAC SG	SG-8	Link VF on CPU unit	Disconnect the programming console when communicating	KOYO KOSTAC-SG8 series	○	x	
			G-01DM					
	KOSTAC SU	SU-5 SU-6	Link VF on CPU unit					
			U-01DM					
		SU-6B	Link VF on CPU unit					
	KOSTAC SZ	SZ-4	Link VF on CPU unit					
	KOSTAC SR	SR-21 SR-22	E-02DM-R1					KOYO KOSTAC-SR21 /22 series
			DL205	D2-240				Link VF on CPU unit*1
	DL405	D4-430 D4-440	D4-DCM					
			Link VF on CPU unit*1					
DL305	D3-330	D3-DCM		KOYO DL-305 Series				
G E F A N U C	Series 90-30	CPU311 CPU331	CPU Direct Connection		GE FANUC SERIES 90 SNP-X	○	x	
			IC693CMM311					
		CPU311 CPU360 CPU313 CPU363 CPU323 CPU364 CPU331 CSE311 CPU340 CSE313 CPU341 CSE323 CPU350 CSE331 CPU351CSE340 CPU352	Serial port on CPU unit		GE FANUC SERIES 90-30/70 SNP			
		CPU731 CPU772 CPU732 CPU781 CPU771 CPU782	IC693CMM711		GE FANUC SERIES 90 SNP-X			
		CPU731 CPX935 CPU771 CGR935 CPU772 CPM790 CPU780 CSE784 CPU781 CSE924 CPU782 CSE925 CPU788 CPX772 CPU789 CPX782 CPM915 CPX928 CPM925 CGR772	Serial port on CPU unit		GE FANUC SERIES 90-30/70 SNP			
F A N U C	FANUC Power Mate (Motion controller)	Power Mate	CPU Direct Connection	Designate the GPs host as a Fanuc PLC. The GP series cannot connect to the CRT/MDI. The handy-type programmer DPL/MDI can be used jointly with the GP series connection type.	FANUC Power Mate series	○	x	
	FANUC Series	16-MC	Link VF on CPU unit	Designate the GPs host as a Fanuc PLC. Only RS232C Serial Port 2 (JP5B) can be used at this time.				

* 1 Connected to CPU module's general communication port.

Co.	Series Name	CPU	Link Unit	Comments	PLC name in PRO/PBIII	GP Series GLC 2400 Series	GLC 100 Series GLC 300 Series
I D E C	FA-2	PF2-CPU1 PF2-CPU5M	CPU Direct Connection	For an RS-232C connection, a link adapter PF2-CLA or computer link interface unit PFA-1U51 is necessary. For RS-422 connection, a link unit PFJ-U21 is necessary.	*1 Refer to the table below .	○	x
	FA-2J	PF2J-CPU1	CPU Direct Connection				
	FA-3S	PF3S-CP11, PF3S-CP12, PF3S-CP13	CPU Direct Connection				
		PF3S-CP12, PF3S-CP13	PF3S-SIF2 PF3S-SIF4				
	MICRO ³	MICRO ³	CPU Direct Connection				
	MICROSmart FC4A Series	FC4A-C10R2B FC4A-C16R2B FC4A-C24R2B	RS-232C Port on CPU module	I D E C FC3/FC4A Series	○	○	
			RS-232C Communication Board (Mini DIN type) FC4A-PC1				
			RS-485 Communication Board (Mini DIN type) FC4A-PC2				
			RS-485 Communication Board (Terminal Type) FC4A-PC3				
	OpenNet Controller FC3 Series	FC3A-CP2K FC3A-CP2S	RS-232C Port on CPU module	○	○		
RS-485 Port on CPU module							
S I E M E N S	SIMATIC S5	90 95U 100U	CP 521 SI	SIEMENS S5 3964(R) Protocol	○	x	
			CPU Direct Connection	SIEMENS S5 90-115 series			
	115U	CP524, CP525	SIEMENS S5 3964(R) Protocol				
		CPU Direct Connecton	SIEMENS S5 90-115 series				
	135U 155U	CP524, CP525	SIEMENS S5 3964(R) Protocol				
			CPU Direct Connection	SIEMENS S5 135-155 series			

*1 When connecting the GP with Izumi Electric's FA Series PLC, setup the object PLC to match the CPU.

CPU	PLC name in PRO/PBIII
PF2-CPU1	IZUMI IDEC_1
PF2J-CPU1, PF3S-CP11	IZUMI IDEC_2
PF2-CPU5M, PF3S-CP12, PF3S-CP13	IZUMI IDEC_3

Co.	Series Name	CPU	Link Unit	Comments	PLC name in PRO/PBIII	GP Series GLC 2400 Series	GLC 100 Series GLC 300 Series
S I E M E N S	SIMATIC S7-200	CPU212, CPU214	CPU Direct Connection		SIEMENS S7-200PPI	○	x
	SIMATIC S7-300	CPU312IFM, CPU313, CPU314, CPU315, CPU315-2DP	CPU Direct (via MPI Port)		SIMATIC S7-300 / 400 via MPI		
			CP340 CP341	3964R via RK512	SIMATIC S7 via 3964 /		
	SIMATIC S7-400	CPU413-2DP	CPU Direct (via MPI Port)		SIMATIC S7-300/400 via MPI		
			CP441-2		SIMATIC S7 via 3964/RK512		
SIMATIC 505	SIMATIC 545-1101, SIMATIC 545-1102, SIMATIC 545-1103, SIMATIC 545-1104, SIMATIC 545-1105, SIMATIC 545-1106, SIMATIC 555-1101, SIMATIC 555-1102, SIMATIC 555-1103, SIMATIC 555-1104, SIMATIC 555-1105, SIMATIC 555-1106	Link I/F on CPU unit		SIMATIC 545/555 CPU	○	x	
A L L E N B R A D L E Y	AB SLC 500	SLC-5/03 SLC-5/04	Link unit on CPU		Allen-Bradley SLC 500 series	○	x
	AB PLC-5	All PLC-5 processors which connect to the link units shown on the right	1785-KE 1770-KF2 1785-KE/C		Allen-Bradley PLC-5 series		
			PLC-5/11 PLC-5/20 PLC-5/30 PLC-5/40 PLC-5/40L PLC-5/60 PLC-5/60L	CPU Direct Connection			
K E Y E N C E	KEYENCE	KZ-300 KZ-350	KZ-L2		Keyence KZ-300 series	○	x
		KZ-A500	CPU Direct Connection		Keyence KZ-A500 (CPU)		
	KZ-L10				Keyence KZ-A500 (Link)		
S H I N K O	SELMART	SELMART	UC1-6		SHINKO SELMART series	○	x

Co.	Series Name	CPU	Link Unit	Comments	PLC name in PRO/PBIII	GP Series GLC 2400 Series	GLC 100 Series GLC 300 Series
M A T S U S H I T A	Panadac 7000	P7000-PLC-001 P7000-PLC-031H P7000-PLC-031S P7000-PLC-A01	GCP001		MATSUSHITA Panadac P7000 series	○	x
M O D I C O N	884/984	884, 984A, 984B	Modbus Port on CPU		MODICON (Master)	○	x
O R I M V E X T A	E1	CPU11	MM01		ORIM VEXTA E1 Series	○	x
F A T E K	Facon FB	20MC	Programming Port on CPU		FATEK FACON FB	○	x



- ***If a PLC maker changes their PLC specifications or upgrades a PLC version, there is a possibility that communication with the GP may not work.***
- ***Depending on the CPU or Link I/F being used, communication speed varies. When designing your system, please check the communication speed.***
- ***If the PLC has a Data Reception (Write) ENABLE/DISABLE feature, used to control the reception of data from external devices while the PLC is in RUN mode, be sure to select [ENABLE] when using the unit.***
- ***The range of devices covered in this manual are only those which can communicate with a GP unit. However, among the PLC maker series names and device names mentioned here, certain devices may not be able to be used with all GP models.***
- ***Please be aware that necessary explanations, not reflected here, concerning GP-PLC connections may be added later.***
- ***GP77R and GP 2000 series unit's baud rate can be set to either 115.2kbps or 57600bps, however, if the PLC does not support the baud rate set on the GP, an error message will appear on the GP's display. The messages will differ depending on the PLC type.***
- ***When screen data is sent at 57600bps or higher to a GP series unit which does not support that rate, the baud rate will automatically change to 38400bps.***

2 PLC-GP Connection

This chapter describes the system configuration of PLC made by various manufacturers and the GP, and shows connection diagrams, supported devices, and examples of setting up the operating environment.





2.1 Mitsubishi Electric

2.1.1 System Structure

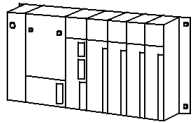

The following describes the system structure for connecting the GP to Mitsubishi Electric PLCs.

Reference  The Cable Diagrams mentioned in the following tables are listed in the section titled "2.1.2 Cable Diagrams".

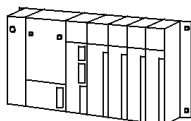

■ MELSEC-A Series (using Link I/F)

CPU	Link I/F	Cable Diagram	Cables	GP
	 Computer Link Unit			
A2A,A3A,A2U, A3U,A4U	AJ71C24-S6	RS-232C (Cable Diagram 1)	Digital's GP410-IS00-0(5m)	GP Series
	AJ71C24-S8		Digital's GP230-IS11-0(5m)	
A2US	AJ71UC24	RS-422 (Cable Diagram 2)	Digital's GP230-IS11-0(5m)	
	A1SJ71C24-R2	RS-232C (Cable Diagram 3)	Digital's GP000-IS02-MS(3m)	
A2USH-S1	A1SJ71UC24-R2	RS-422 (Cable Diagram 2)	Digital's GP230-IS11-0	
	A1SJ71UC24-R4	RS-422 (Cable Diagram 2)	Digital's GP230-IS11-0	
	A1SJ71UC24-R2	RS-232C (Cable Diagram 3)	Digital's GP000-IS02-MS(3m)	

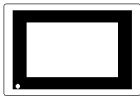
■ MELSEC-N Series (using Link I/F)

CPU	Link I/F	Cable Diagram	Cables	GP
	 Computer Link Unit			
A1N, A2N, A3N,	AJ71C24 AJ71C24-S3 AJ71C24-S6 AJ71C24-S8 AJ71UC24(Only A2N)	RS-232C (Cable Diagram 1)	Digital's GP410-IS00-0(5m)	GP Series
A0J2, A0J2H	AOJ2-C214-S1	RS-422 (Cable Diagram 2)	Digital's GP230-IS11-0	
A1S	A1SJ71C24-R2 A1SJ71UC24-R2	RS-232C (Cable Diagram 3)	Digital's GP000-IS02-MS(3m)	
A1SJ, A2SH, A1SH	A1SJ71C24-R4	RS-422 (Cable Diagram 2)	Digital's GP230-IS11-0(5m)	
	A1SJ71UC24-R2	RS-232C (Cable Diagram 3)	Digital's GP000-IS02-MS(3m)	
A2CCPU24	Link I/F unit on CPU	RS-232C (Cable Diagram 3)	Digital's GP000-IS02-MS(3m)	

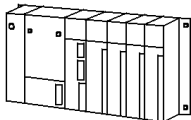
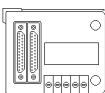
■ MELSEC-A Series (CPU Direct Connection)

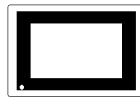

CPU *1	Adapter	Cable Diagram	Cables	GP
				
A2A, A3A, A4U, A3U, A2U-S1, A2US-S1, A2USH-S1, A2US			Digital's A-Series Programming Console I/F Cable (isolation type) GP430-IP10-O(5m)	GP Series
A2A, A3A, A4U, A3U, A2U-S1, A2US-S1, A2USH-S1, A2US	Digital's 2 Port Adapter *2 GP030-MD11-0	RS-422 (Refer to Mitsubishi's A Series PLC Manual "2 Port adapter II " for cable diagram information)		
A2A, A4U, A2U-S1 A2US, A3A, A2USH-S1	Digital's 2 Port Adapter II *3 GP070-MD11	RS-422 (Refer to Mitsubishi's A Series PLC Manual "2 Port adapter II " for cable diagram information)	Digital's GP070- MDCB11(5m) cable or user's own made RS- 422Cable	
	Mitsubishi's I/F unit FX- 2PIF	Refer to Mitsubishi's manual		

*1 Connect to the Programming Console I/F port.

*2 When a Read/Write command is sent from ladder software while data is being transmitted between the PLC and the GP, there is a possibility the data transmission will not be completed normally.

*3 When using 2 Port Adapter II, refer to its manual for the connectable PLCs.

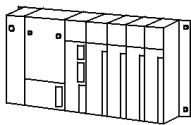
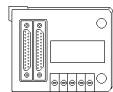
■ MELSEC-N Series (CPU Direct Connection)

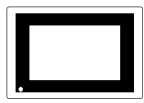
CPU *1	Adapter	Cable Diagram	Cables	GP
				
A1N,A2N,A3N,A3H, A1S,A2SH, A2CJ-S3,A1SH, A2CCPUC24,A1SJ, A0J2H			Digital's A-Series exclusive Programing Console I/F Cable(isolation type) GP430-IP10-0(5m)	GP Series
A1N,A2N,A3N,A3H, A1S,A2SH,A1SJ, A1SH	Digital's 2 Port Adapter *2 GP030-MD11-0	RS-422 (Refer to Mitsubishi's A Series PLC Manual "2 Port adapter " for cable diagram information)		
A1S,A2N,A3H, A3N,A1SJ,A2SH A1SH,A2CJ-S3, A0J2H	Digital's 2 Port Adapter II *3 GP070-MD11	RS-422 (Refer to Mitsubishi's A Series PLC Manual "2 Port adapter " for cable diagram information)	Digital's GP070-MDCB11(5m) or user's own made cable (RS-422)	
	Mitsubishi's Interface Unit FX-2PIF	Refer to Mitsubishi's PLC Manual		

*1 Connect to the Programming Console I/F port.

*2 When a Read/Write command is sent from ladder software while data is being transmitted between the PLC and the GP, there is a possibility the data transmission will not be completed normally.



*3 When using 2 Port Adapter II, refer to its manual for the connectable PLCs.





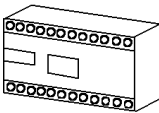
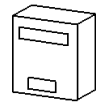

Caution

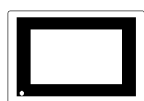
- If you connect a CPU not listed here via the Direct CPU connection, you may damage the PLC.
- If the PLC has two ports, both of them cannot be connected to a GP at the same time.

■ MELSEC-F₂ Series (using Link I/F)

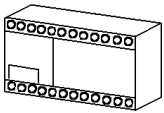
CPU	Adapter	Cable Diagram	Cables	GP
	 Interface Unit			
F2-20M, F2-40M, F2-60M	F2-232GF	RS-232C (Cable Diagram 1)	Digital's GP410-IS00-0(5m)cable, Mitsubishi's F2-232CAB(3m)cable	GP Series

■ MELSEC-FX Series (CPU Direct Connection)

CPU	Adapter	Cable Diagram	Cables	GP
				
FX ₁ *2 FX ₂ *2 FX _{2c} *2 FX ₀ , *3 *4 FX _{2N} -64MR *3 *4 FX _{2NC} -32MT *3 FX _{0N} -60MR *3 *4	Mitsubishi's I/F unit FX-232AW *1	RS-232C (Cable Diagram 1)	Digital's FX Series exclusive Programming Console I/F Cable (isolation type) GP430-IP11-0 (5m)	GP Series
FX ₂ *5 FX _{2N} -64MR *6 FX _{2NC} -32MT *6 FX _{0N} -60MR *6	Digital's 2 Port Adapter II GP070-MD11 *8	Refer to Mitsubishi's PLC 2 Port Adapter II for A series Manual	Digital's GP070-MDCB11 or User-Prepared cable (RS-422)	
A1FX *7			Digital's GP410-IS00-0(5m) Mitsubishi's F2-232CAB(3m)	
	Digital's 2 Port Adapter II GP070-MD11 *8	Refer to Mitsubishi's PLC 2 Port Adapter II for A series Manual	Digital's GP070-MDCB11 or User-Prepared cable (RS-422)	

*1 Although MELSEC-FX Series and the GP uses a CPU direct connection, to change an RS-422 signal to RS-232C's, the FX-232AW interface unit is necessary.

When connecting to FX₁, FX₂, and FX_{2c}, it is necessary to connect the Interface Unit with the PLC using Mitsubishi's FX-422CAB.

Diagram 1

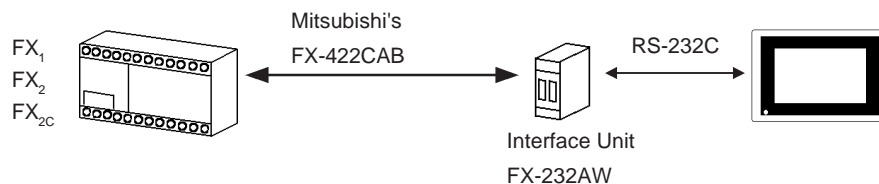

*2 When using Digital's GP430-IP11-0 for connecting an FX₁, FX₂, or FX_{2c}, use the Cable Diagram 2 shown below.

Diagram 2

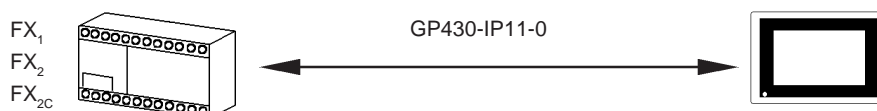

*3 When using Digital's GP430-IP11-0 for connecting FX_0 , FX_{2N} -64MR, FX_{2NC} -32MT or FX_{0N} -60MR, use Cable Diagram 3 shown.

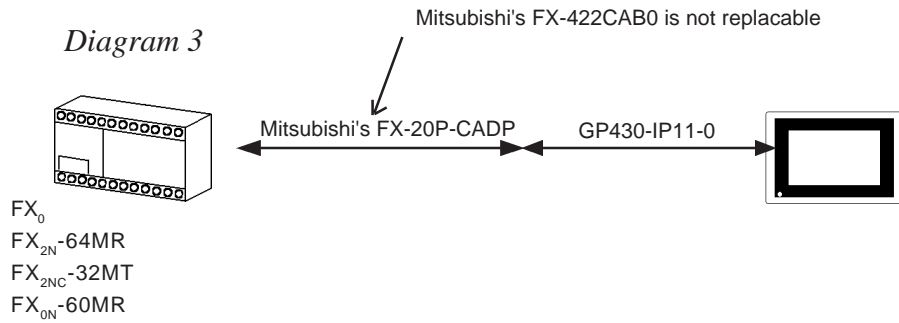

*4 When connecting to FX_0 , FX_{2N} -64MR, FX_{0N} -60MR, it is necessary to connect the Interface Unit with the PLC using Mitsubishi's RS-422CAB and FX-20P-CADP (see Diagram 4).

Diagram 4

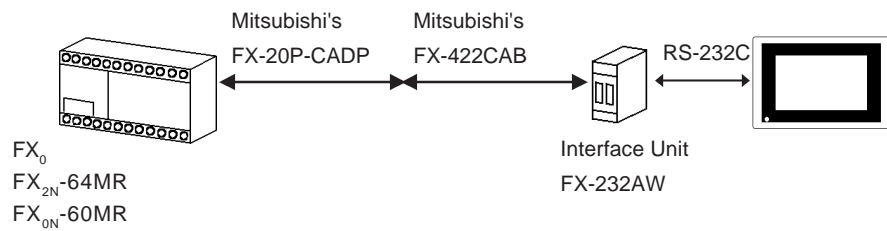

*5 When using Digital's 2 Port Adapter II, it is necessary to connect the unit to the GP as shown below.

Diagram 5 < When using the FX_2 >

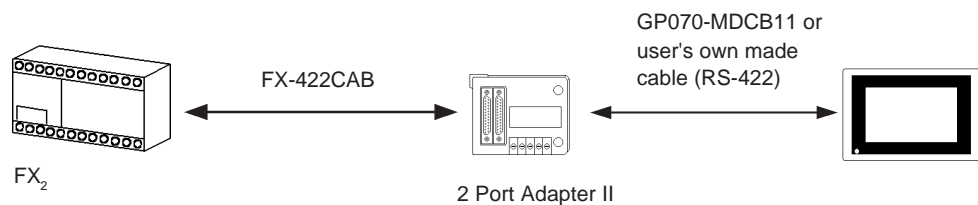

*6 When using Digital's 2 Port Adapter II, it is necessary to connect the units to the GP as shown below.

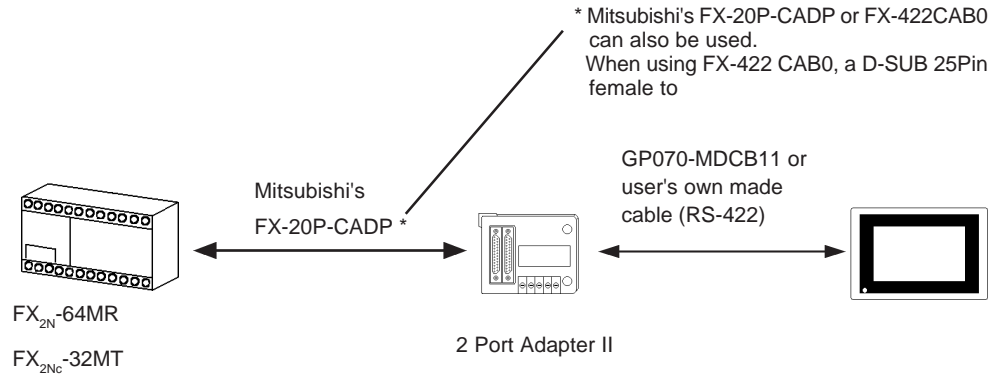
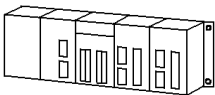
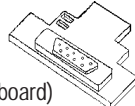

Diagram 6 < When using the FX_{2N}-64MR or FX_{2Nc}-32MT >



*7 When using an A1FX, choose the MELSEC-N series as the GP-PRO/PBIII project file's PLC type (refer to the MELSEC-N series manuals for the range of devices available). You will also need an adaptor to adjust the connector's height to align it with that of the PLC's CPU cover.

*8 When using 2 Port Adapter II, refer to its manual for the connectable PLCs



■ MELSEC-FX Series (using Expansion Board with Link Protocol)*1

CPU	Adapter	Cable Diagram	GP
 FX _{2N} *2	 (Expansion board)		 GP Series
	FX2N-232-BD	(Cable Diagram 6) (RS-232C)	
	FX2N-485-BD	(Cable Diagram 7) (RS-422)	

*1 Choose the Mitsubishi MELSEC-FX₂(LINK) selection as the GP-PRO/PB III project file's PLC type.

*2 The PLC's system version should be at least 1.06 or later. Check the PLC's version by reading out the data from the register (D8001). For detailed information refer to the Mitsubishi's FX 2N Series Micro Sequencer manuals.

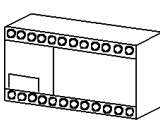
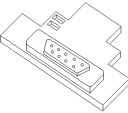
■ MELSEC-FX Series (Expansion board using CPU Direct Connection protocol)*1

CPU	Adapter	Cable Diagram	Cables	GP
	 (Expansion board)			
FX _{2N} -64MR	FX _{2N} -232-BD (Diagram 1)	RS-232C *2 (Cable Diagram 1)	Digital's GP410-IS00-0 (5m) Mitsubishi's F2-232CAB(5m)	GP Series
		RS-232C (Cable Diagram 4)		
	FX _{2N} -422-BD *3 (Diagram 2)		Digital's FX-Series exclusive Programming Console I/F Cable (isolation type) GP430-IP11-0 (5m)	

*1 Choose the Mitsubishi MELSEC-FX(CPU) selection as the PLC type in the GP-PRO/PB III screen creation software.

*2 Since a 9-pin connector is used by the PLC, a 25-pin conversion adapter is required.

Diagram 1

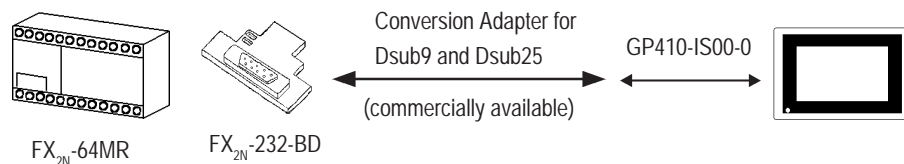



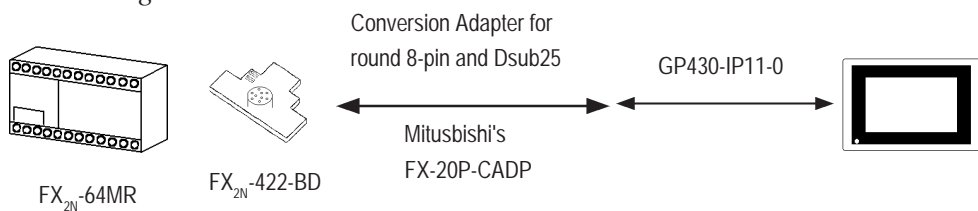

*3 A round 8-pin to 25-pin conversion cable, (Mitsubishi Electronic FX-20P-CADP) is required.

Diagram 2

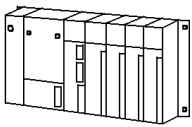



■ MELSEC-QnA Series (using Link I/F)

CPU	Adapter	Cable Diagram	Cables	GP
	 Serial Communication Unit / Computer Link Unit			
Q2A Q2A-S1 Q4A	AJ71QC24 (Serial Communication Unit) *1	RS-232C (Cable Diagram 1)	Digital's GP410-IS00-0(5m)	GP Series
	AJ71UC24 (Computer Link Unit)	RS-422 (Cable Diagram 2)	Digital's GP230-IS-11-0(5m)	
	AJ71QC24N-R4	RS-422 (Cable Diagram 2) for CN-2	Digital's GP230-IS-11-0(5m)	
		RS-422 (Cable Diagram 5) for CN-1		
Q2AS Q2ASH	A1SJ71QC24 (Serial Communication Unit) *2	RS-232C (Cable Diagram 3)	Digital's GP000-IS02-MS (3m)	
	A1SJ71UC24 (Computer Link Unit)	RS-422 (Cable Diagram 2)	Digital's GP230-IS-11-0(5m)	
Q2AS-S1	A1SJ71UC24-R2 A1SJ71UC24-R4	RS-232C (Cable Diagram 3)	Digital's GP000-IS02-MS (3m)	
		RS-422 (Cable Diagram 2)	Digital's GP230-IS-11-0(5m)	
	A1SJ71QC24N	RS-232C (Cable Diagram 3)	Digital's GP000-IS02-MS (3m)	
		RS-422 (Cable Diagram 2)	Digital's GP230-IS-11-0(5m)	
Q4AR	AJ71QC24N	RS-232C (Cable Diagram 1)	Digital's GP410-IS00-0(5m)	
		RS-422 (Cable Diagram 2)	Digital's GP230-IS-11-0(5m)	

*1 ROM : must be 7179B or higher.

*2 ROM : must be 7179M or higher.

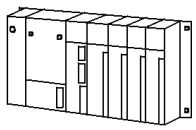
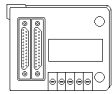
■ MELSEC-QnA Series (CPU Direct Connection)

CPU	Adapter	Cable Diagram	Cables	GP
				
Q2A Q4A Q2AS Q2AS-S1 Q4AR			Digital's A Series exclusive Programming Console I/F cable (isolation type) GP430-IP10-O (5m)	GP Series
Q2A Q4A Q2AS Q2AS-S1	Digital's 2 Port Adapter ^{*1} GP030-MD11-O ^{*2}	RS-422 (Refer to "Mitsubishi's PLC 2 Port Adapter Manual" for cable diagram information)		
Q2A Q4A Q2AS-S1 Q2ASH	Digital's 2 Port Adapter II ^{*1} GP070-MD11 ^{*2}	Refer to "Mitsubishi's PLC A Series 2 Port Adapter II ^{*1} Manual"	Digital's GP070-MDCB11 or user's own cable (RS422)	

*1 When using 2 Port Adapter II, refer to its manual for the connectable PLCs.





*2 When a Read/Write command is sent from ladder software while data is being transmitted between the PLC and the GP, there is a possibility the data transmission will not be completed normally. You may need to set the GP to the OFFLINE mode before you Read/Write in the program



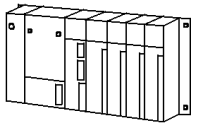

Digital's 2-port Adapter (GP030-MD11-0) will have this identification label.

Adapters that support the MELSEC-QnA unit have a circle around the "B" or later character.

■ MELSEC-Q Series (using Link I/F)

CPU	Link I/F	Cable Diagram	Cable	GP
	 Serial Communication Unit / Computer Link Unit			
Q02CPU-A Q02HCPU-A Q06HCPU-A	A1SJ71UC24-R4	RS-422 <Cable Diagram 2>	Digital's GP230-IS11-0	GP Series
	A1SJ71UC24-R2	RS-232C <Cable Diagram 3>	Digital's GP000-IS02-MS (3m)	
Q02CPU Q02HCPU Q06HCPU Q12HCPU Q25HCPU	QJ71C24	RS-422 <Cable Diagram 2>	Digital's GP230-IS11-0	
	QJ71C24-R2	RS-232C <Cable Diagram 3>	Digital's GP000-IS02-MS (3m)	
		RS-232C <Cable Diagram 3>	Digital's GP000-IS02-MS (3m)	

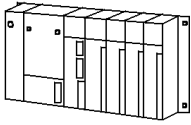
■ MELSEC-QnA Series (CPU Direct Connection)

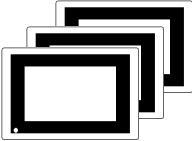
CPU	Link I/F	Cable Diagram	Cable	GP
				
Q02CPU Q02HCPU Q06HCPU Q12HCPU Q25HCPU		RS-232C <Cable Diagram 8>	Mitsubishi's QC30R2 (9pin/25pin conversion adaptor is necessary.)	GP Series
	RS-232C <Cable Diagram 9>	Diatrend's DQCABR2 (3m) *1		

*1 When designating the length of a cable, be sure to use meters (*m).

For the available range of cable lengths, please contact the Diatrend company.

2.1.2 Cable Diagrams

The cable diagram illustrated below and the cable diagrams recommended by Mitsubishi Electric Corporation may differ. Using these cables for your PLC, however, will not cause any problems.



Ground your PLC's FG terminal according to your country's applicable standard. For details, refer to the corresponding PLC manual.



- **Connect the FG line of the Shield cable to either the GP or PLC, depending on your environment. When using a connector hood and grounding the FG line, be sure to use an electrical conductor. The following connection diagrams show examples for connecting a shielded cable to the PLC.**
- **For the RS-232C connection, use a cable length less than 15m.**
- **If a shielded cable is connected to the RS-422 port, it must be no longer than 600 m.**
- **If a communications cable is used, it must be connected to the SG (signal ground).**

Cable Diagram 1 (RS-232C)

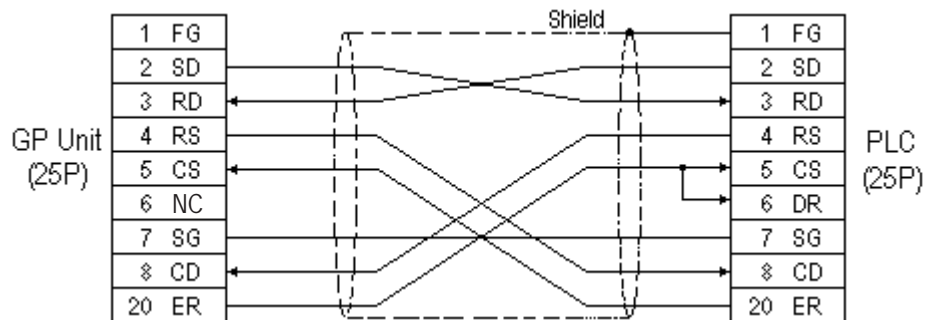

Cable Diagram 2 (RS-422)

- When using Digital's RS-422 connector terminal adapter GP070-CN10-0



- **Turn on the PLC's termination resistance switch.**
- **Depending on the type of PLC used, a termination resistance of 330Ω 1/2W is needed between SDA and SDB, and also between RDA and RDB if no DIP switch is available.**

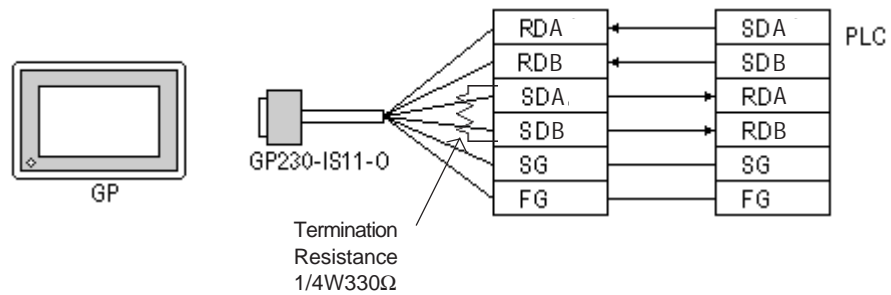
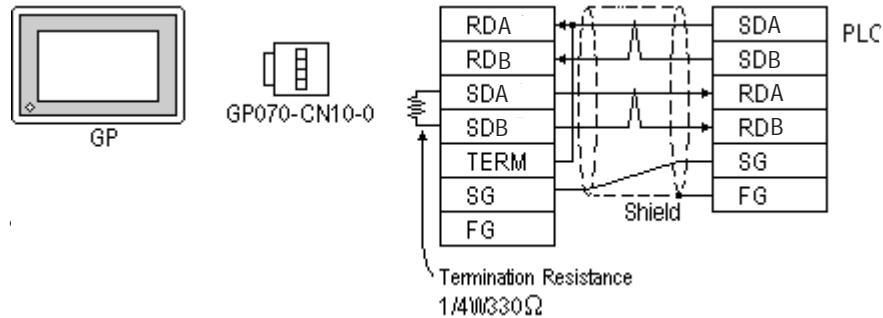

- When making your own cable connections

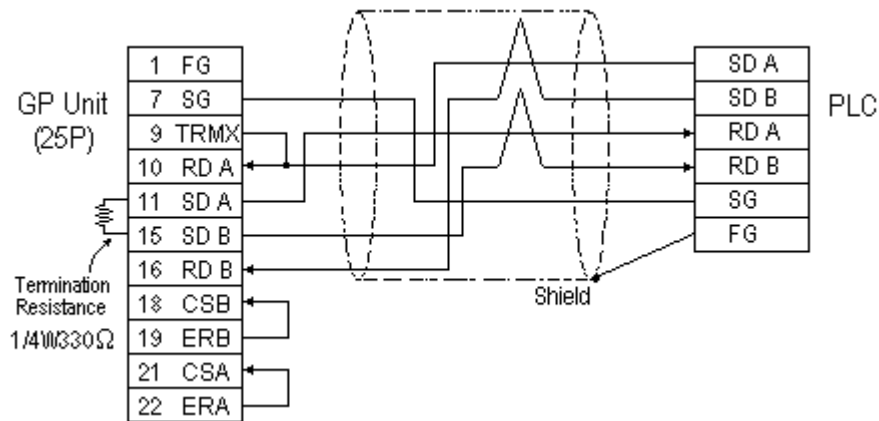

- When making your own cable connections, we recommend using Mitsubishi's SPEV (SB)-MPC-0.2*3P for the cable.
- When connecting the #9 and #10 pins in the GP Serial I/F, a termination resistance of 100Ω is added between RDA and RDB.



A termination resistance of 1/2W 330Ω is needed between the PLC connector's SDA and SDB, and also between RDA and RDB.

Cable Diagram 3 (RS-232C)

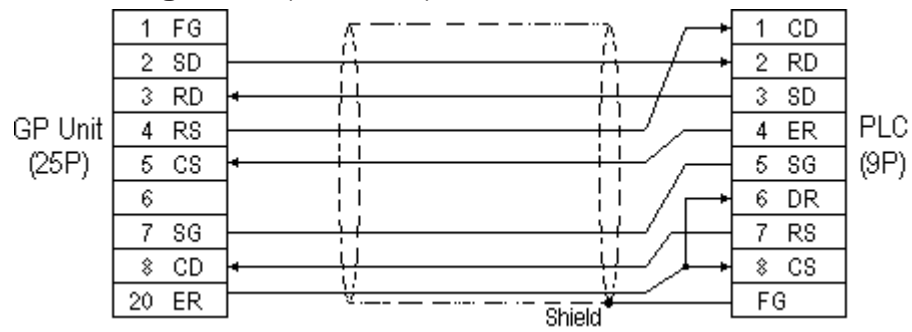

Connect the Shield to the PLC's FG terminal.

Cable Diagram 4 (RS-232C)

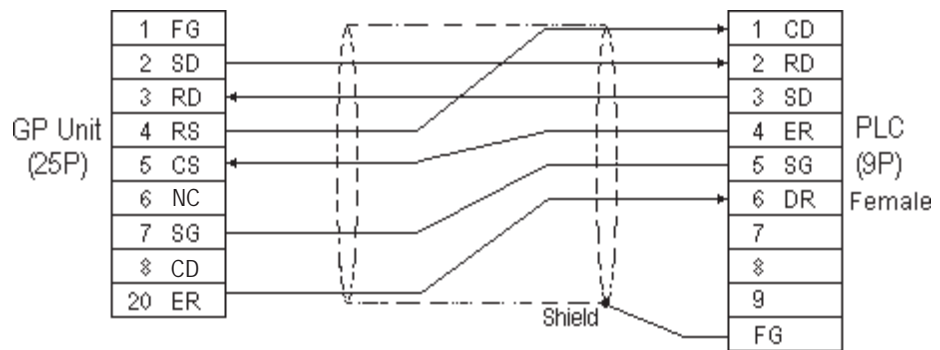

Cable Diagram 5 (RS-422)

- When using Digital's RS-422 connector terminal adapter GP070-CN10-0

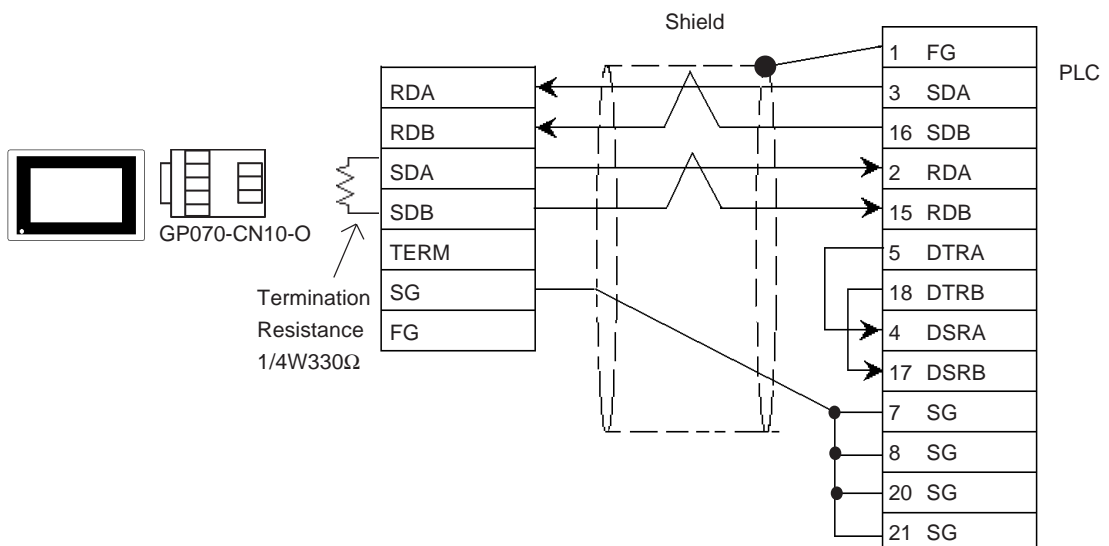

- When using Digital's RS-422 connector terminal adapter GP230-IS11-0

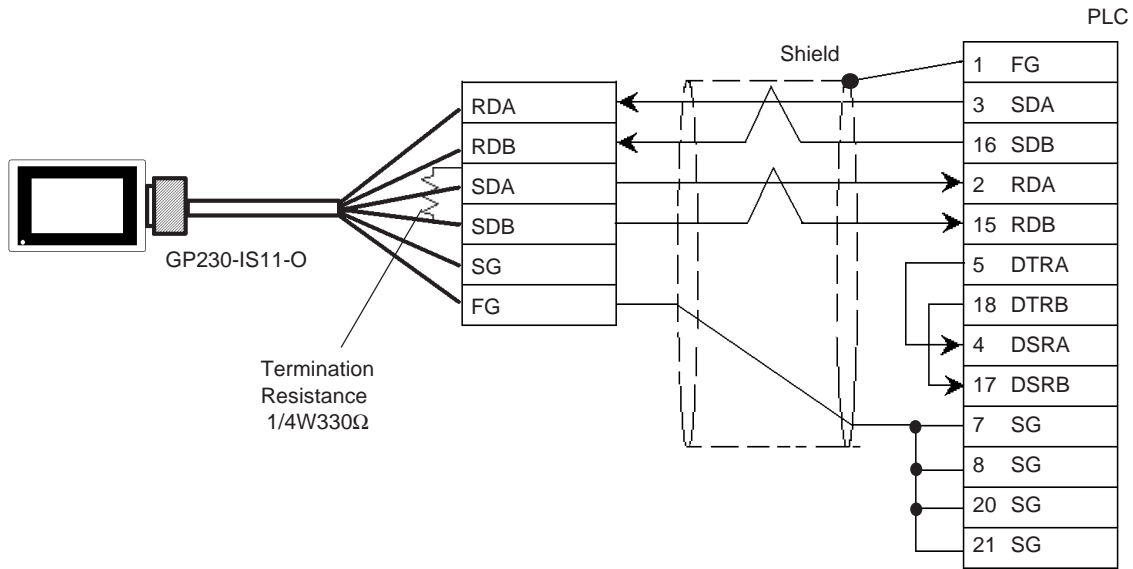

- When making your own cable

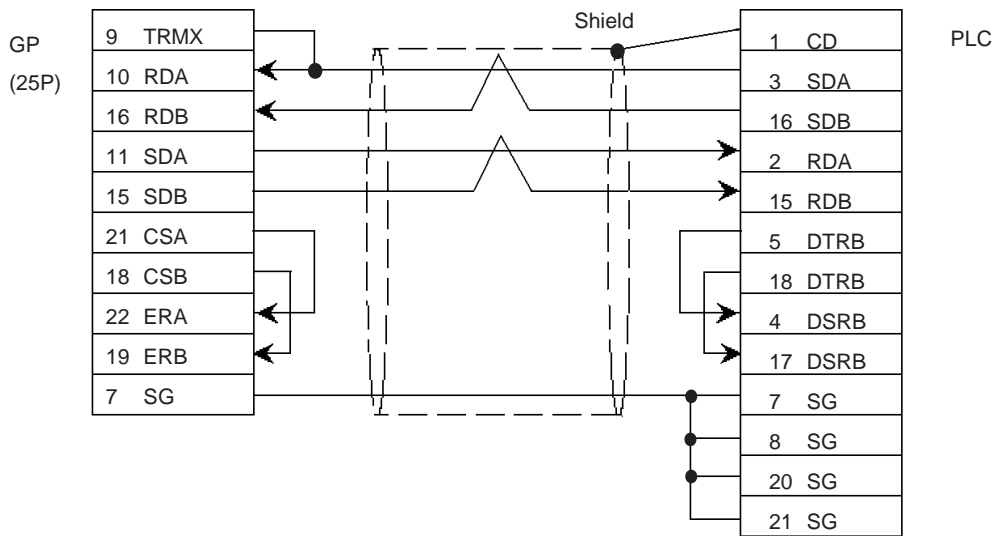

Cable Diagram 6 (RS-232C)

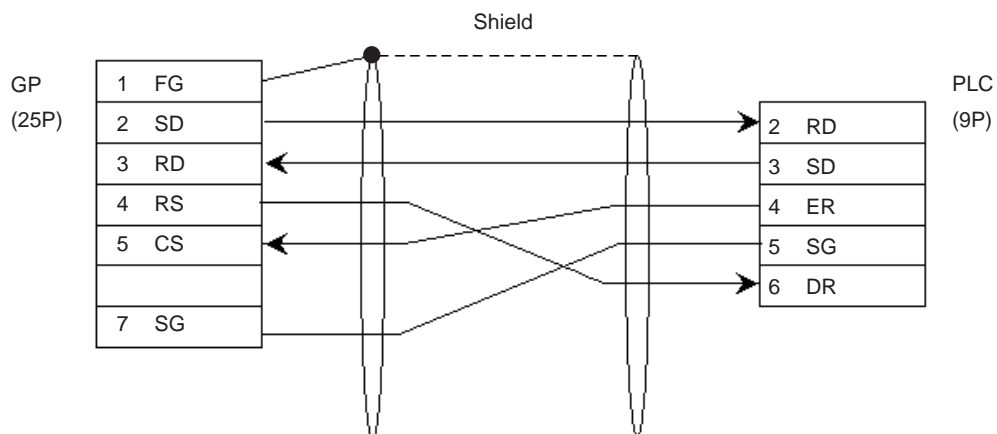

Cable Diagram 7 (RS-422)



- A termination resistance of 330Ω is needed between the PLC connector's SDA and SDB, and also between RDA and RDB.
- When using the FX2N-485-BD, be sure the cable is less than 50 meters.
- When using Digital's RS-422 connector terminal adapter GP070-CN10-0

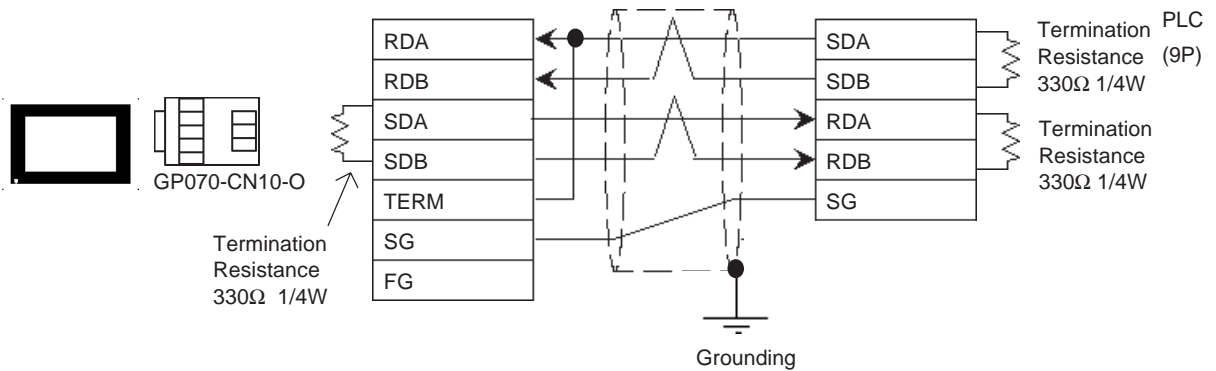

- When using Digital's RS-422 connector terminal adapter GP230-IS11-0

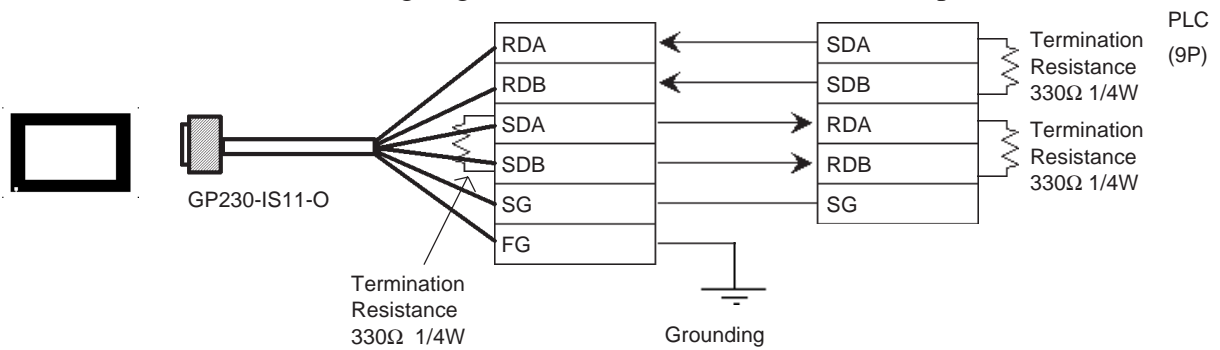

- When making your own cable

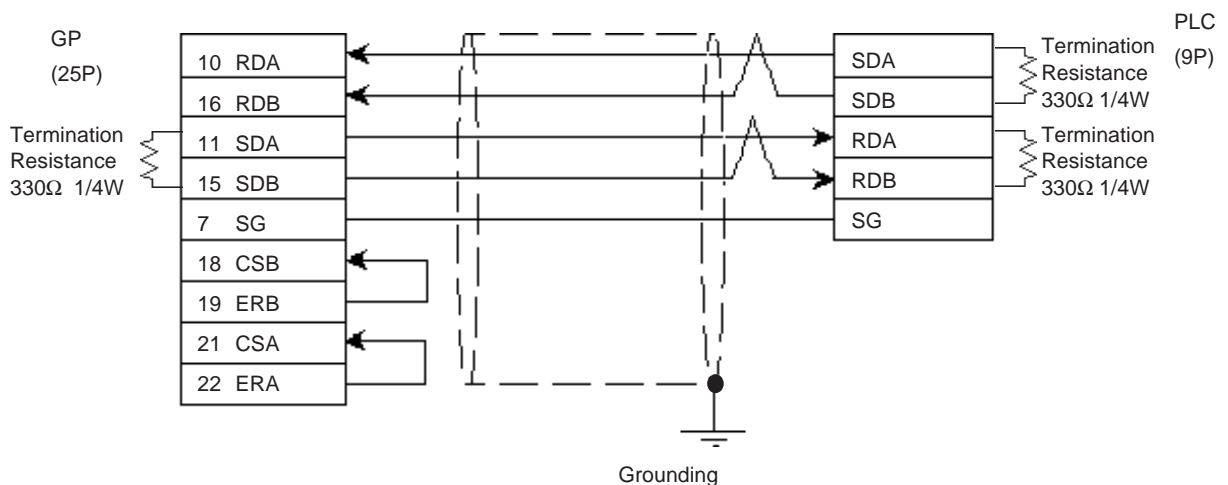

Digital recommends Mitsubishi Electric's SPEV(SB)-0.2-2P cable for this connection.



- **Attaching a Ferrite Core will reduce the amount of noise in your cable.**
- **Attach two (2) Ferrite Cores to your cable, one at each end. Also, as shown in the drawing below, loop the cable once around the Ferrite Core.**
- **When using a data communication cable that is 3m(approx. 10ft.) or longer, please use a cable made by the Diatrend company.**
- **Be sure all cables are less than 15 meters long.**

Cable Diagram 8 (RS-232C)

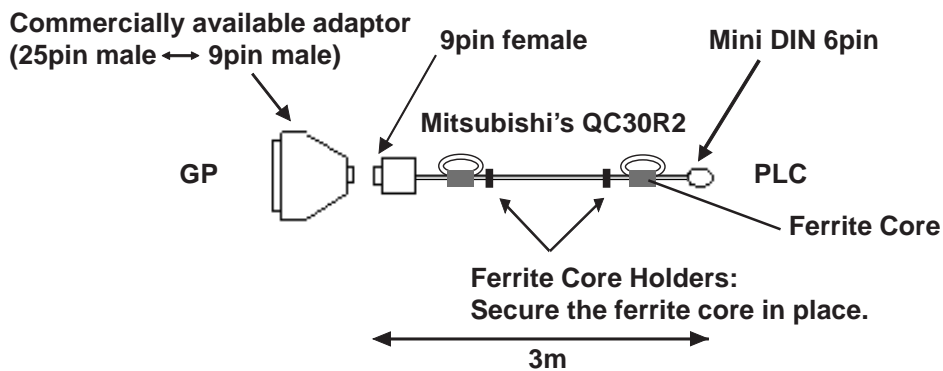

<Reccomended Ferrite Core>

Maker :Seiwa Electronics Corporation

Model :E04SR301334

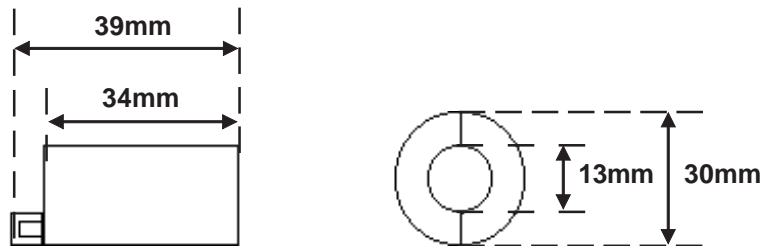

Conversion Adaptor Specifications

- Straight connection type
- D-Sub 25pin male Lock-screw (mm)
- D-Sub 9pin male Lock nut (inch)

<Adaptor : Roas Co. Model No. ZA-403>

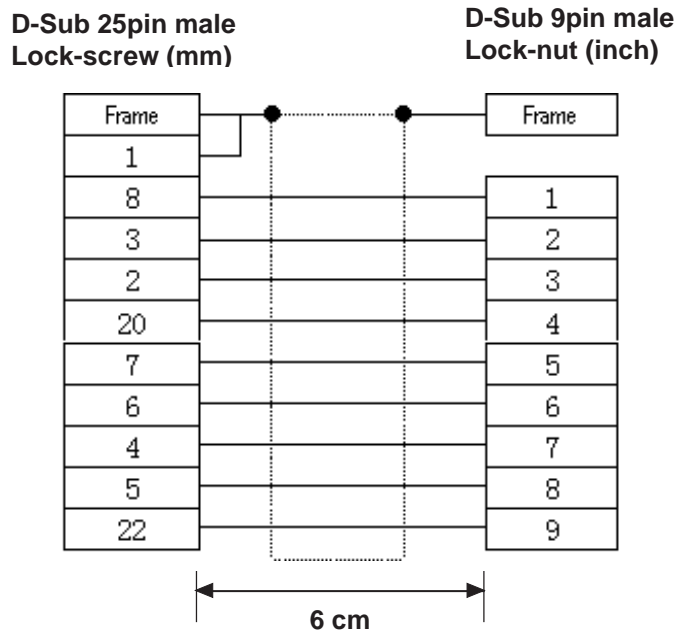

- **Attaching a Ferrite Core will reduce the amount of noise in your cable.**
- **Attach two (2) Ferrite Cores to your cable, one at each end. Also, as shown in the drawing below, loop the cable once around the Ferrite Core.**
- **When using a data communication cable that is 3m(approx. 10ft.) or longer, please use a cable made by the Diatrend company.**
- **Be sure all cables are less than 15 meters long.**

Cable Diagram 9 (RS-232C)

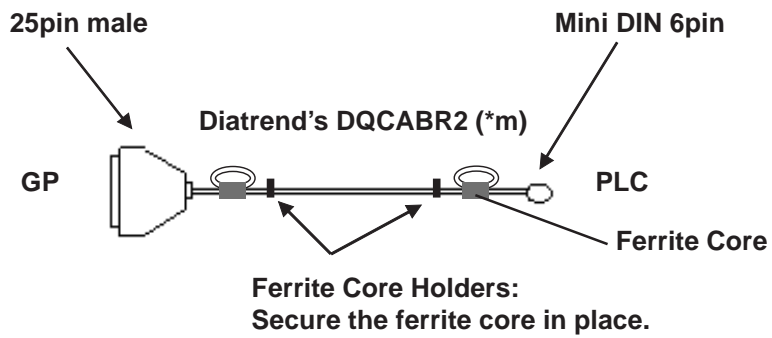

<Reccomended Ferrite Core>

Maker :Seiwa Electronics Corporation

Model :E04SR301334

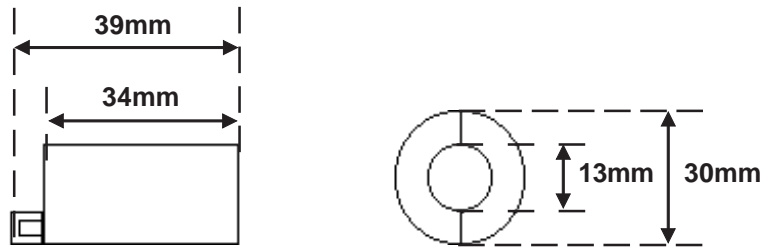











Note: Any other maker's ferrite core can be also used. (The size should be the same as shown here.)

2.1.3 Supported Devices

The following table describes the range of devices supported by the GP.

MELSEC-A Series (AnA/ AnU/ A2US/ A2USH-S1)

 Setup System Area here.

Device	Bit Address	Word Address	Particulars
Input Relay	X0000 ~ X1FFF	X0000 ~ X1FF0	
Output Relay	Y0000 ~ Y1FFF	Y0000 ~ Y1FF0	
Internal Relay	M0000 ~ M8191	M0000 ~ M8176	
Latch Relay	L0000 ~ L8191	L0000 ~ L8176	
Special Relay	M9000 ~ M9255	M9000 ~ M9240	
Annunciator	F0000 ~ F2047	F0000 ~ F2032	
Link Relay	B0000 ~ B1FFF	———	
Timer (contact)	TS0000 ~ TS2047	———	
Timer (coil)	TC0000 ~ TC2047	———	
Counter (contact)	CS0000 ~ CS1023	———	
Counter (coil)	CC0000 ~ CC1023	———	
Timer (current value)	———	TN0000 ~ TN2047	
Counter (current value)	———	CN0000 ~ CN1023	
Data Register	———	D0000 ~ D8191	
Special Register	———	D9000 ~ D9255	
Link Register	———	W0000 ~ W1FFF	
File Register	———	R0000 ~ R8191	 *1

L/H

*1 When using the File Register on AnA or AnU, use the User's Memory area in the memory cassettes listed below.

A3NMCA-0 A3NMCA-2 A3NMCA-4 A3NMCA-8

A3NMCA-16 A3NMCA-24 A3NMCA-40 A3NMCA-56

A4UMCA-8E (only when using CPU Direct Communication)

When the File Register is setup and the memory cassette is not in use, an error will develop when communicating.



Caution

If a ladder program is stored in ROM when a direct connection is used, there may be cases where the file register may not be used.

■ MELSEC-N Series (AnN/ A2C/ A1S/ A3H/A0J2/A1SJ/A2SH/A1SH/A2CJ-S3)

 Setup System Area here.

Device	Bit Address	Word Address	Particulars
Input Relay	X0000 ~ X07FF	X0000 ~ X07F0	***0
Output Relay	Y0000 ~ Y07FF	Y0000 ~ Y07F0	***0 *1
Internal Relay	M0000 ~ M2047	M0000 ~ M2032	÷16
Latch Relay	L0000 ~ L2047	———	
Special Relay	M9000 ~ M9255	M9000 ~ M9240	÷16 *2
Annunciator	F000 ~ F255	F000 ~ F240	÷16
Link Relay	B0000 ~ B03FF	———	
Timer (contact)	TS000 ~ TS255	———	
Timer (coil)	TC000 ~ TC255	———	
Counter (contact)	CS000 ~ CS255	———	
Counter (coil)	CC000 ~ CC255	———	
Timer (current value)	———	TN000 ~ TN255	
Counter (current value)	———	CN000 ~ CN255	
Data Register	———	D0000 ~ D1023	Bit15
Link Register	———	W0000 ~ W03FF	BitF
File Register	———	R0000 ~ R8191	Bit15 *3

L/H

- * 1 With the A2C, the Output Relays Y01F0~Y01FF (the word is Y01F0) cannot be setup for use on the PLC (only for A2C).
- * 2 MELSEC-AnN and AJ71C24-S3 (or AJ71C24) cannot be matched and used.
- * 3 When using the File Register on AnN or A3H, use the User's Memory area in the memory cassettes listed below.

A3NMCA-0 A3NMCA-2 A3NMCA-4 A3NMCA-8
 A3NMCA-16 A3NMCA-24 A3NMCA-40 A3NMCA-56
 A4UMCA-8E (only when using CPU Direct Connection)

When the File Register is setup when the memory cassette is not in use, an error will develop when communicating.



If a ladder program is stored in ROM when a direct connection is used, there may be cases where the file register can not be used.

■ MELSEC-F₂ Series



Setup System Area here.

Device	Bit Address	Word Address	Particulars
Input Relay (X)	000 ~ 013, 400 ~ 413, 500 ~ 513	———	
Output Relay (Y)	030 ~ 037, 430 ~ 437, 530 ~ 537	———	
Timer (contact)(T)	050 ~ 057, 450 ~ 457, 550 ~ 557, 650 ~ 657	———	
Counter (contact)(C)	060 ~ 067, 460 ~ 467, 560 ~ 567, 660 ~ 667	———	
Hold Relay (M)	070 ~ 077, 100 ~ 177, 200 ~ 277, 470 ~ 477, 570 ~ 577	———	
Keep Relay (M)	300 ~ 377	———	
State (S)	800 ~ 877, 900 ~ 977, 600 ~ 647	———	
Timer (current v alue)	———	TC050 ~ TC057 TC450 ~ TC457 TC550 ~ TC557 TC650 ~ TC657	
Timer (set v alue)	———	TS050 ~ TS057 TS450 ~ TS457 TS550 ~ TS557 TS650 ~ TS657	
Counter (current v alue)	———	CC060 ~ CC067 CC460 ~ CC467 CC560 ~ CC567 CC660 ~ CC667	
Counter (set v alue)	———	CS060 ~ CS067 CS460 ~ CS467 CS560 ~ CS567 CS660 ~ CS667	
Data Register	———	DW700 ~ DW777	







Since the word addresses in F₂ Series' *Timer, Counter, and Data Register* bit length is 12, some tag functionality (i.e. N-tag, S-tag, C-tag, etc.) is limited.



You cannot use 2 word (32 bit) data.

■ MELSEC-FX Series (FX₀)









 Setup System Area here.

Device	Bit Address	Word Address	Particulars
Input Relay	X000 - X017	X000	
Output Relay	Y000 - Y015	Y000	
Internal Relay	M000 - M511	M000 - M496	
State	S000 - S063	S000 - S048	
Timer (contact)	TS000 - TS055	———	
Counter (contact)	CS000 - CS015	———	
Timer (current value)	———	TN000 - TN055	
Counter (current value)	———	CN000 - CN015	
Data Register	———	D000 - D031	

L/H

■ MELSEC-FX Series (Using Expansion Board with Link Protocol)

 Setup System Area here.

Device	Bit Address	Word Address	Particulars
Input Relay	X0000 - X0267	X0000 - X0240	 
Output Relay	Y0000 - Y0267	Y0000 - Y0240	 
Auxiliary Relay	M0000 - M3071	M0000 - M3056	
State	S0000 - S0991	S0000 - S0976	
Special Auxiliary relay	M8000 - M8255	M8000 - M8240	 *1
Timer (contact)	TS000 - TS255	———	
Counter (contact)	CS000 - CS255	———	
Timer (current)	———	TN000 - TN255	
Counter (current)	———	CN000 - CN255	*2
Data Register	———	D0000 - D7999	
Special Data Register	———	D8000 - D8255	 *1







L/H

*1 The Special Auxiliary Relay and the Special Data Register are divided into three areas. These are the Exclusive Reading Area, the Exclusive Writing Area and the System Area. For details, refer to your PLC's manual.

*2 Word addresses CN200 to CN255 are 32 bit counters.

■ MELSEC-FX Series (FX₁/FX₂/FX_{2N}-64MR/FX_{0N}-60MR, using CPU Direct Connection)

 Setup System Area here.

Device	Bit Address	Word Address	Particulars
Input Relay	X000 - X337	X000 - X320	  *2
Output Relay	Y000 - Y337	Y000 - Y320	 
Internal Relay	M0000 - M1535	M0000 - M1520	
State	S000 - S999	S000 - S976	
Timer (contact)	TS000 - TS255	——	L/H
Counter (contact)	CS000 - CS255	——	
Timer (current value)	——	TN000 - TN255	
Counter (current value)	——	CN000 - CN255 *1	
Data Register	——	D000 - D999	

* 1 Addresses CN200 to CN255 are 32 bits long.

















* 2 Cannot perform data write.



- The FX_{2N}-64MR can only be used for the range of devices listed above.
- Refer to the MELSEC-N series manuals for the A1FX's range of available devices.

■ MELSEC-QnA Series (using Computer Unit AJ71QC24/A1SJ71QC24N/AJ71QC24N-R4/AJ71QC24N or using CPU Direct Connection)

 Setup System Area here.

Device	Bit Address	Word Address	Particulars
Input Relay	X0000 ~ X1FFF	X0000 ~ X1FF0	
Output Relay	Y0000 ~ Y1FFF	Y0000 ~ Y1FF0	
Internal Relay	M00000 ~ M32767	M00000 ~ M32752	
Special Relay	SM0000 ~ SM2047	SM0000 ~ SM2032	
Latch Relay	L00000 ~ L32767	L00000 ~ L32752	
Annunciator	F00000 ~ F32767	F00000 ~ F32752	
Edge Relay	V00000 ~ V32767	V00000 ~ V32752	
Step Relay	S0000 ~ S8191	S0000 ~ S8176	
Link Relay	B0000 ~ B7FFF	B0000 ~ B7FF0	
Special Link Relay	SB000 ~ SB7FF	SB000 ~ SB7F0	
Timer (contact)	TS00000 ~ TS22527	——	
Timer (coil)	TC00000 ~ TC22527	——	
Aggregate Timer (contact)	SS00000 ~ SS22527	——	
Aggregate Timer (coil)	SC00000 ~ SC22527	——	
Counter (contact)	CS00000 ~ CS22527	——	
Counter (coil)	CC00000 ~ CC22527	——	
Timer (current value)	——	TN00000 ~ TN22527	
Aggregate Timer (current value)	——	SN00000 ~ SN22527	
Counter (current value)	——	CN00000 ~ CN22527	
Data Register	——	D00000 ~ D25599	
Special Data Register	——	SD0000 ~ SD2047	
Link Data Register	——	W0000 ~ W63FF	
Special Link Register	——	SW000 ~ SW7FF	
File Register (normal)	——	R00000 ~ R32767	 *1
File Register (serial)	——	0R0000 ~ 0R7FFF : 1R0000 ~ 1R7FFF	 *1

L/H

* 1 When using File Register, a Memory Card is necessary.

Usable capacity of the File Register varies depending on the capacity of the Memory Card.

■ MELSEC-QnA Series (using Computer Unit AJ71UC24/A1SJ71UC24-R2/A1SJ71UC24-R4)

Setup System Area here.

Device	Bit Address	Word Address	Particulars
Input Relay	X0000 ~ X03FF	X0000 ~ X03F0	***0
Output Relay	Y0000 ~ Y03FF	Y0000 ~ Y03F0	***0
Internal Relay	M00000 ~ M8191	M00000 ~ M8176	÷16
Special Relay	SM1000 ~ SM1255	SM1000 ~ SM1240	÷16 *1
Annunciator	F0000 ~ F2047	F0000 ~ F2032	÷16
Link Relay	B0000 ~ B0FFF	———	***0
Timer (contact)	TS0000 ~ TS2047	———	
Timer (coil)	TC0000 ~ TC2047	———	
Counter (contact)	CS0000 ~ CS1023	———	
Counter (coil)	CC0000 ~ CC1023	———	
Timer (current value)	———	TN0000 ~ TN2047	
Counter (current value)	———	CN0000 ~ CN1023	
Data Register	———	D0000 ~ D6143	Bit15
Special Data Register	———	SD1000 ~ SD1255	Bit15 *1
Link Register	———	W0000 ~ W0FFF	BitF

L/H

**1 Table data will change depending on whether the perspective is from the PLC or the User's PC.*

Device	GP-PRO/PBIII	PLC Manual
Special Relay	M9000 ~ M9255	SM1000 ~ SM1255 (cannot use SM0000~SM0999)
Special Register	D9000 ~ D9255	SD1000 ~ SD1255 (cannot use SD0000~SD0999)

◆ MELSEC-QnA series communications mode selection (when using a link unit)

When using the MELSEC-QnA series unit, either mode 2 or mode 1 can be selected during the entering of the initial settings, when the GP is in the OFFLINE mode.

Mode 2: This is a new communications mode. It is enabled when less than 64 devices have been designated by a single screen's tags. The communications speed has been improved. Select this mode when using less than 64 devices.











Mode 1: This mode is equivalent to the communications mode used previously. This mode is valid for 64 or more devices have been specified by a single screen's tags. The communications speed has been improved. Select this mode when using 64 or more devices.



- ***If the on-screen data memory area in the GP is initialized or if the on-screen data is transferred from the drawing software, the GP returns to mode 1 (its initial setting). Use the offline settings area to select mode 2.***
- ***In mode 2, the communications speed may not always be improved depending on which tags and system area are used, as well as how the PLC's read areas are allocated.***

■ MELSEC-Q Series (A mode CPU)

 Setup System Area here.

















Device	Bit Address	Word Address	Particulars
Input Relay	X0000 ~ X1FFF	X0000 ~ X1FF0	
Output Relay	Y0000 ~ Y1FFF	Y0000 ~ Y1FF0	
Internal Relay	M0000 ~ M8191	M0000 ~ M8176	
Latch Relay	L0000 ~ L8191	L0000 ~ L8176	
Special Relay	M9000 ~ M9255	M9000 ~ M9240	
Annunciator	F0000 ~ F2047	F0000 ~ F2032	
Link Relay	B0000 ~ B1FFF	————	
Timer (contact)	TS0000 ~ TS2047	————	
Timer (coil)	TC0000 ~ TC2047	————	
Counter (contact)	CS0000 ~ CS1023	————	
Counter (coil)	CC0000 ~ CC1023	————	
Timer (current value)	————	TN0000 ~ TN2047	
Counter (current value)	————	CN0000 ~ CN1023	
Data Register	————		
Special Data Register	————	D9000 ~ D9255	
Link Register	————	W0000 ~ W1FFF	
File Register	————	R0000 ~ R8191	 *1

L/H

* 1 When using a File Register, a Memory Card is necessary. Usable capacity of the File Register will vary depending on the capacity of the Memory Card.

■ MELSEC-Q Series (Q mode CPU)

 Setup System Area here.

Device	Bit Address	Word Address	Notes
Input Relay	X0000 - X1FFF	X0000 - X1FF0	
Output Relay	Y0000 - Y1FFF	Y0000 - Y1FF0	
Internal Relay	M00000 - M32767	M00000 - M32752	
Special Relay	SM0000 - SM2047	SM0000 - SM2032	
Latch Relay	L0000 - L32767	L0000 - L32752	
Annunciator	F0000 - F32767	F0000 - F32752	
Edge Relay	V0000 - V32767	V0000 - V32752	
Step Relay	S0000 - S8191	S0000 - S8176	
Link Relay	B0000 - B7FFF	B0000 - B7FF0	
Special Link Relay	SB000 - SB7FF	SB000 - SB7F0	
Timer (contact)	TS00000 - TS23087	———	
Timer (coil)	TC00000 - TC23087	———	
Aggregate Timer (contact)	SS00000 - SS23087	———	
Aggregate Timer (coil)	SC00000 - SC23087	———	
Counter (contact)	CS00000 - CS23087	———	
Counter (coil)	CC00000 - CC23087	———	
Timer (current value)	———	TN00000 - TN23087	
Aggregate Timer (current value)	———	SN00000 - SN23087	
Counter (current value)	———	CN00000 - CN23087	
Data Register	———	D00000 - D25983	
Special Data Register	———	SD0000 - SD2047	
Link Data Register	———	W0000 - W657FF	
Special Link Register	———	SW000 - SW7FF	
File Register (normal)	———	R00000 - R32767	 *1
File Register (serial)	———	0R0000 - 0R7FFF	 *1
	———	1R0000 - 1R7FFF : 31R0000 - 31R67FF	 *1

L/H

*1 When using a File Register, a Memory Card is necessary. Usable capacity of the File Register will vary depending on the capacity of the Memory Card.

2.1.4 Environment Setup

The following lists Digital's recommended PLC and GP communication settings.



Items affecting the PLC program cycle—

Please be aware that PLC program cycle time slows by approximately 8% when you connect the GP to the programming port and begin communications with the GP.

■ MELSEC-A Series / N Series (using Calculation Link Unit)

GP Setup		Computer Link Unit Settings	
Baud Rate	19200 bps	Baud Rate	19200 bps
Data Length	7 bits	Data Bit	7 bits
Stop Bit	2 bits	Stop Bit	2 bits
Parity Bit	Even	Parity Check Parity setting even/odd	Yes Even
Data Flow Control	ER Control	---	
Communication Format (RS-232C)	RS-232C	Channel Setup ^{*1} Mode Setup (RS-232C)	RS-232C 4 (Format 4 protocol)
Communication Format (RS-422)	4-wire type	Channel Setup ^{*1} Mode Setup (RS-422)	RS-422 8 (Format 4 protocol)
---		Write possible in RUN mode.	Possible
---		Sum Check	Yes
---		Enable Sender Termination Resistor ^{*2}	Yes
---		Enable Receiver Termination Resistor ^{*2}	Yes
Unit No.	0	Station Number	0

*1 A1SJ71C24-R2, A1SJ71UC24-R2, and A1SJ71C24-R4 do not have this setting.

*2 The A171UC24 does not have this setting.

■ MELSEC-A Series / N Series (CPU Direct Connection)

GP Setup		PLC Settings
Baud Rate	9600 bps (fixed)	---
Data Length	8 bit (fixed)	---
Stop Bit	1 bit (fixed)	---
Parity Bit	Odd (fixed)	---
Data Flow Control	ER Control	---
Communication Format ^{*1} (RS-232C)	RS-232C	---
Communication Format (RS-422)	4-wire type	---
Unit No.	0 (fixed)	---

**1 Only when using Digital's Programming Console I/F cable(GP430-IP10-0) for the A series unit. Otherwise a 4-wire type cable is required.*

■ MELSEC-A2C

GP Setup		A2C Settings	
Baud Rate	19200 bps	Baud Rate	19200 bps
Data Length	8 bits	Data Bit	8 bits
Stop Bit	1 bit	Stop Bit	1 bit
Parity Bit	Even	Parity Check Parity setting even/oddd	Yes Even
Data Flow Control	ER Control	---	
Communication Format	RS-232C	Channel Setup Mode Setup	RS-232C 4 (Format 4 protocol)
---		Write possible in RUN mode	Possible
---		Sum Check	Yes
Unit No.	0	Station Number	0

■ MELSEC-F₂ Series

GP Setup		Interface Settings	
Baud Rate	9600 bps	Baud Rate	9600 bps
Data Length	7 bits	Data Bit	7 bits
Stop Bit	1 bit (fixed)	Stop Bit	1 bit (fixed)
Parity Bit	Even	Parity Bit	Even
Data Flow Control	ER Control	---	
Communication Format	RS-232C	---	
---		Resistor Setting	Yes
---		Sum Check	Yes
Unit No.	0	Station Number	0

■ MELSEC-FX Series (using Expansion Board with Link Protocol)

GP Setup		Computer Link Unit Settings	
Baud Rate	19200 bps	Baud Rate	19200 bps
Data Length	7 bits	Data Bit	7 bits
Stop Bit	2 bits	Stop Bit	2 bits
Parity Bit	Even	Parity Bit	Even
Data Flow Control	ER Control	---	
Communication Format (RS-232C)	RS-232C	Computer Link	RS-232C I/F
Communication Format (RS-422)	4-wire type	Computer Link	RS485 (RS422) I/F
Unit No.	0	Station Number	0
---		Sum Check	Yes
---		Protocol	Yes
---		Control Method	4
---		Header	No
---		Terminator	No



The PLC's Station Number setting must be written to data register D8121, and all other PLC settings for the PLC must be written to data register D8120. For details, please refer to the Mitsubishi Electronics FX Series User Manual.

■ MELSEC-FX Series *1 (CPU Direct Connection)

GP Setup		FX Series Settings
Baud Rate	9600 bps (fixed)	---
Data Length	7 bits (fixed)	---
Stop Bit	1 bit (fixed)	---
Parity Bit	Even (fixed)	---
Data Flow Control	ER Control	---
Communication Format	RS-232C	---
Unit No.	0 (fixed)	---

*1 The A1FX unit's settings are the same as the MELSEC-N Series (CPU Direct Connection).



When the adapter (FX_{2N}-232-BD) is used, store "0" data in D8120.

■ MELSEC-QnA (using Serial Communication Unit)

GP Setup		Serial Communication Unit Settings	
Baud Rate	19200 bps ^{*1}	Baud Rate	19200 bps
Data Length	7 bits	Data Bit	7 bits
Stop Bit	2 bits	Stop Bit	2 bits
Parity Bit	Even	Parity Check Parity setting even/odd	Yes Even
Data Flow Control	ER Control	---	
Communication Format (RS-232C)	RS-232C	Mode Setup (RS-232C)	4 (Format 4 Protocol Mode)
Communication Format (RS-422)	4-wire type	Mode Setup (RS-422)	4 (Format 4 Protocol Mode)
---		Sum Check	Yes
---		Enable Sender Termination Resistor	Yes
---		Enable Receiver Termination Resistor	Yes
Unit No.	0	Station Number	0

*1 AJ71QC24-R4 , AISJ71QC24N and AJ71QC24N can use a baud rate of 115200bps.



- When your environment setup involves using MELSEC-QnA and the Computer Link Unit AJ71UC24 together, refer to the MELSEC A Series' table.
- Serial communication units CH1 and CH2 can communicate at the same time, given any of the following conditions are true.
 - Condition 1 : The sticker on the top of the communication unit indicates the version is AB or later.
 - Condition 2 : The date shown on the side of the communication unit indicates it was produced in September 1996(9609) or later.
 - Condition 3 : The communication unit's ROM version is 7179M or later.

■ MELSEC-QnA (CPU Direct Connection)

GP Setup		PLC Settings
Baud Rate	19200 bps	---
Data Length	8 bits	---
Stop Bit	1 bit	---
Parity Bit	Odd	---
Data Flow Control	ER Control	---
Communication Format ^{*1} (RS-232C)	RS-232C	---
Communication Format (RS-422)	4-wire type	---
Unit No.	0 (fixed)	---

*1 Only when using Digital 's Programming Console I/F cable (GP430-IP10-0) for the A series unit. Otherwise a 4-wire type cable is required.

■ MELSEC-Q Series (A Mode CPU Direct Connection)

GP Setup		PLC Settings
Baud Rate	9600bps (fixed)	——
Data Length	8bit (fixed)	——
Stop Bit	1bit (fixed)	——
Parity Bit	Odd (fixed)	——
Data Flow Control	ER Control	——
Communication Format	RS-232C	——
Unit No.	0 (fixed)	——

■ MELSEC-Q Series (Q Mode CPU Direct Connection)

GP Setup		PLC Settings
Baud Rate	19200 bps	——
Data Length	8bit (fixed)	——
Stop Bit	1bit (fixed)	——
Parity Bit	Odd (fixed)	——
Data Flow Control	ER Control (fixed)	——
Communication Format	RS-232C (fixed)	——
Unit No.	0 (fixed)	——

■ MELSEC-Q Series (using A Mode CPU Computer Link Unit)

GP Setup		Computer Link Unit Settings	
Baud Rate	19200bps (fixed)	Baud Rate	19200 bps
Data Length	7bits (fixed)	Data Bit	7 bits
Stop Bit	2bits (fixed)	Stop Bit	2 bits
Parity Bit	Even	Parity Check Parity setting even/odd	Yes Even
Data Flow Control	ER Control	---	
Communication Format (RS-232C)	RS-232C	Mode Setup (RS-232C)	4 (Format 4 Protocol Mode)
Communication Format (RS-422)	4-wire type	Mode Setup (RS-422)	4 (Format 4 Protocol Mode)
-	-	Write possible in RUN mode	Possible
-	-	Sum Check	Yes
Unit No.	0 (fixed)	Station Number	0

■ MELSEC-Q Series (Q Mode CPU Serial Communication Unit)

GP Setup		Serial Communication Unit Settings ^{*1}	
Baud Rate	19200bps	Baud Rate	19200 bps
Data Length	7 bits	Data Bit	7 bits
Stop Bit	2 bits	Stop Bit	2 bits
Parity Bit	Even	Parity Check Parity setting even/odd	Yes Even
Data Flow Control	ER Control	---	
Communication Format (RS-232C)	RS-232C	Mode Setup (RS-232C)	4 (Format 4 Protocol Mode)
Communication Format (RS-422)	4-wire type	Mode Setup (RS-422)	4 (Format 4 Protocol Mode)
---		Sum Check	Yes
Unit No.	0	Station Number	0

***1 The setting is made by Mitsubishi's GPP function software.**

2.1.5 2-Port Feature

The 2-Port feature can be used in two ways:

- (1) Via the GP's built-in 2-Port feature
- (2) Via the external 2-Port Adapter II.

Both methods are described below:

■ When Using GP unit's Internal 2-Port feature *1

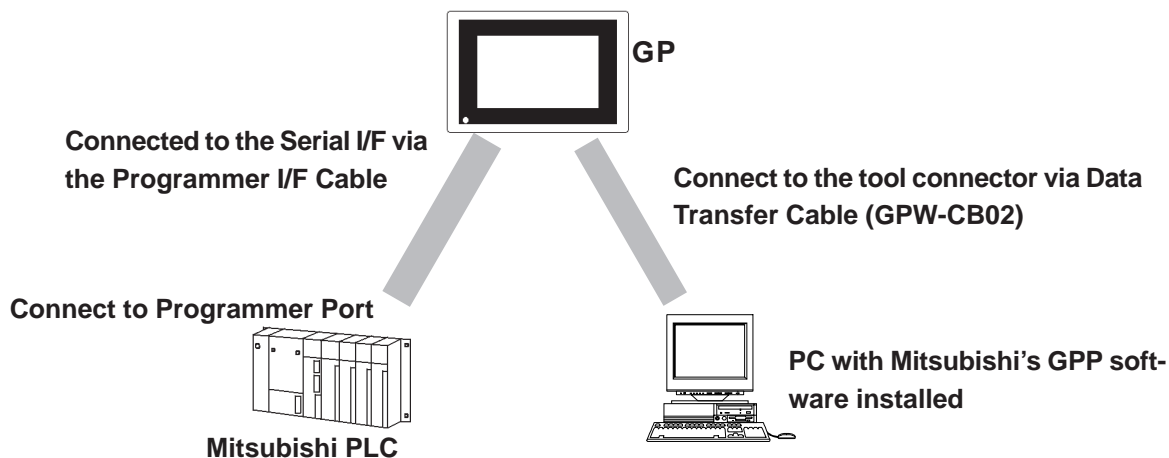

*1 The Device Monitor feature can also be used at the same time.

◆ PLC models supporting Internal 2-Port Feature

Series	CPU
MELSEC-AnA Series	A2A, A2U-S1, A2USH-S1, A3A, A2US
MELSEC-AnN Series	A1S, A1SH, A2N, A3H, A2SH, A3N, A0J2H
MELSEC-QnA Series	Q2A, Q2A-S1, Q2AS-S1, Q2ASH, Q4A
MELSEC-FX Series *1	FX2N, FX2NC, FX0N
MELSEC-Q Series	Q02CPU-A, Q02HCPU-A, Q06HCPU-A, Q02CPU, Q02HCPU, Q06HCPU, Q12HCPU, Q25HCPU

*1 MELSEC-FX Series' FX2 cannot use the internal 2-Port feature.

◆ GP models supporting Internal 2-Port Feature

Series	GP type
GP-377 Series	GP-377L
	GP-377S
GP77R Series	GP-377R Series
	GP-477R Series
	GP-577R Series
GP2000 Series	GP-377RT
	GP-477RE
	GP-577RT GP-577RS
GP2000 Series	GP-2400
	GP-2500
	GP-2600

◆GPP Feature Software Package

MELSEC-A Series	NEC 98 Series SW2NX-GPPA type GPP feature software package or later DOS/V Series SW31VD-GPPA type GPP feature software package or later Windows95, Windows NT SW0D5*-GPPW type GPP feature software package or later
MELSEC-QnA Series	NEC 98 Series SW0NX-GPPQ type GPP feature software package DOS/V Series SW01VD-GPPQ type GPP feature software package Windows95, Windows NT SW0D5*-GPPW type GPP feature software package or later
MELSEC-FX Series	Windows 95 SW0PC-FXGP/WIN type GPP feature software package Windows 95, Windows NT SW4D5C-GPPW type GPP feature software package or later
MELSEC-Q Series	Windows 95, Windows NT SW4D5C-GPPW type GPP feature software package or later

■Internal 2-Port Feature Usage Notes



- The selections “USE ADAPTER MODE/CPU DIRECT MODE” will be displayed only when a direct CPU connection is used.
- The factory setting will become “Adapter”(the setting when using 2-Port Adapter II).
- This feature can be used only while the GP is in ONLINE mode.
- Use the Digital's transfer cable GPW-CB02.



- ***If you transfer screen data while the GP is in ONLINE mode, the screen will not change to the data transfer screen automatically. Thus, you will need to change the screen manually to the OFFLINE mode's [Main Menu/ Transfer] screen.***
- ***Since the internal 2-Port feature uses the GP's single tool connector, you will not be able to use optional equipment which requires the tool connector (i.e. a Barcode Reader, etc.)***
- ***Peripheral equipment which cannot be connected to the GP's tool connector (such as a Programming Console) is not compatible with the GP's Internal 2-Port feature. To use this type of equipment, you will need to use the external 2- Port Adapter II.***
- ***When using the GP's built-in 2-Port feature, be sure not to switch to OFFLINE mode while the GPP software is communicating with the PLC. Switching to OFFLINE mode will result in a communication (data transfer) break***
- ***With GP77R series units, if the 2-Port feature is designated, the Simulation feature cannot be used. Be sure to select “Adapter” or “Direct” when using the Simulation feature.***



- When using the GP's built-in 2-Port feature with the MELSEC-Q Series, be sure to set your PC's data link speed to the same values as used by the GP. If the setting values are different, an error will appear on the GP and your PC. The error will appear as shown below.

<GP>

"PC's data link speed is different. (02:F5)"

<PC>

"Cannot communicate with the PC."

<e.g : GP-377 series unit's screen>

- ① Touch item, PLC SETTING.
The SET UP OPERATION SURROUNDINGS menu will appear.

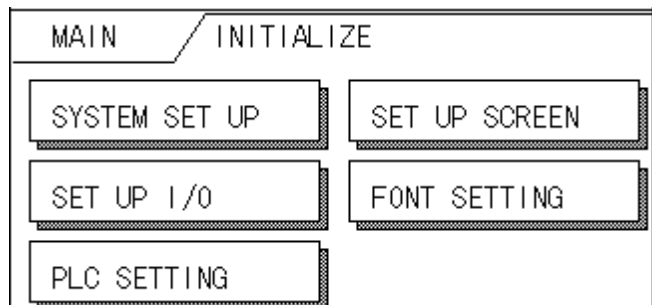

- ② Touch the button, SET on the upper right on the screen.
The SET UP OPERATION SURROUNDINGS 2 menu appears.

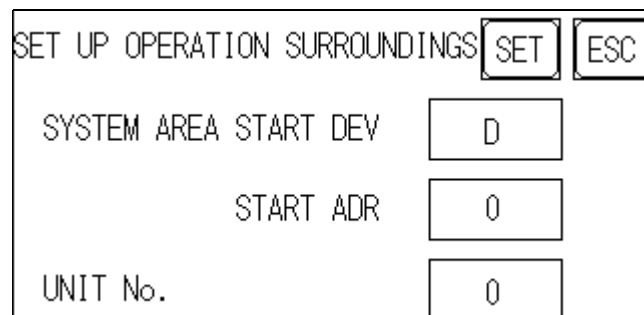

- ③ Touch the "2-Port Feature/CPU Direct" selection's right side setting box until "INSIDE" appears. When using the 2-Port Adapter II unit, select "Adapter", or "CPU" for a direct CPU connection.

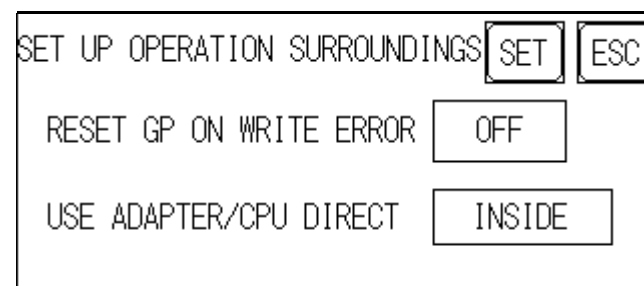

■ When Using the External 2-Port Adapter Cable *1

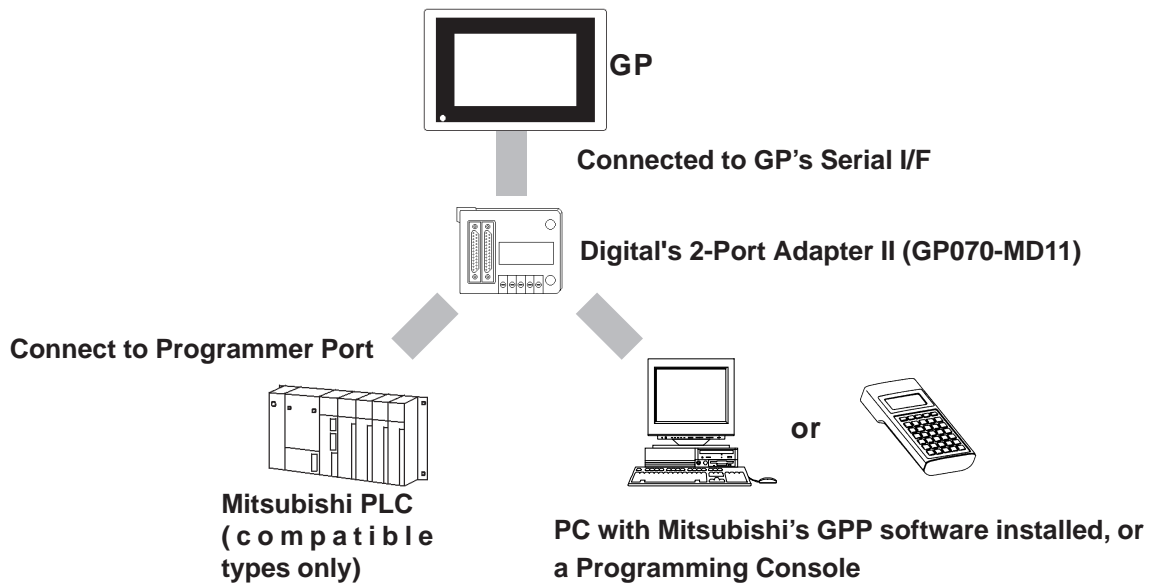

*1 2-Port Adapter can be used for the GP series units supporting the internal 2-Port feature .

■ PLCs supported by the 2-Port Adapter II



Note: For information about which CPUs the 2-Port Adapter II (GP070-MD11) can connect to, refer to the 2-Port Adapter II Users Manual.

■ When Using the 2-Port Adapter II

Set up from the GP's OFFLINE mode when using 2-Port Adapter II.

Reference GP User Manual (Sold separately), "OFFLINE Mode"

◆ GP70 Series (except GP-377 series)



- The selections "USE ADAPTER MODE/CPU DIRECT MODE" will be displayed only when a direct CPU connection is used.
- The factory setting will become "2 Port".

<e.g : GP-570 series unit's screen>

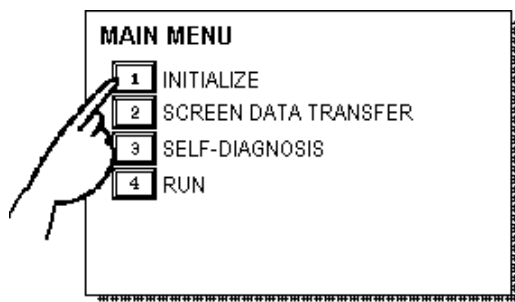

- ① Touch item #1, INITIALIZE. The INITIALIZE menu will appear.

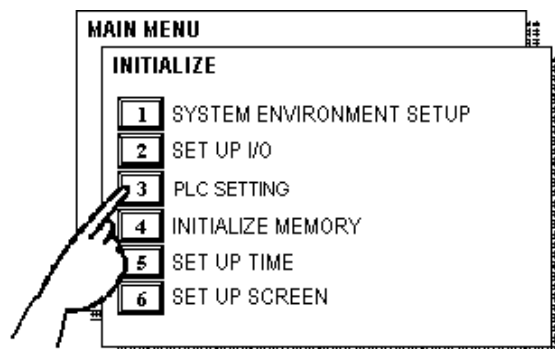

- ② Touch item #3, PLC SETTING. The PLC SETTING menu appears.

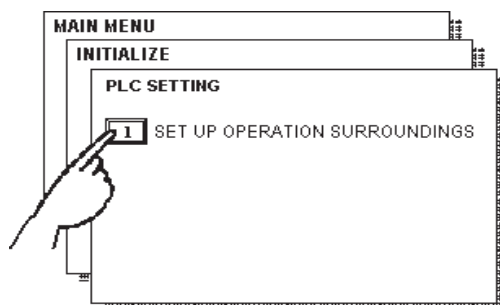

- ③ Touch item #1, SET UP OPERATION SURROUNDINGS. The SET UP OPERATION SURROUNDINGS menu will appear.

SET UP OPERATION SURROUNDINGS	[]
STARTING ADDRESS OF SYSTEM DATA AREA	[]
UNIT NO.	[]
SYSTEM AREA READING AREA SIZE (0-256)	[]
RESET GP ON DATA WRITE ERROR	ON OFF
USE ADAPTER MODE/CPU DIRECT MODE	<input checked="" type="radio"/> 2PORT <input type="radio"/> 2PORT+GPH <input type="radio"/> CPU

GP70 Series Units

- ④ Touch the “USE ADAPTER MODE/CPU DIRECT MODE” selection. The selected item is highlighted.

- ⑤ When using the 2 port adapter II (GP070-MD11), select the *2PORT* option. For *GP70* however, select *2PORT + GPH*. Select CPU when connecting CPU directly.

◆ GP77R/GP2000 Series



- The selections “2 Port Mode/CPU DIRECT MODE” will be displayed only when a direct CPU connection is used.
- The factory setting will become “Adapter”.

<e.g : GP-577R series unit's screen>

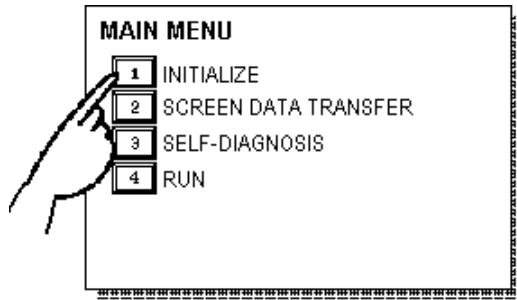

- ① Touch item #1, INITIALIZE. The INITIALIZE menu will appear.

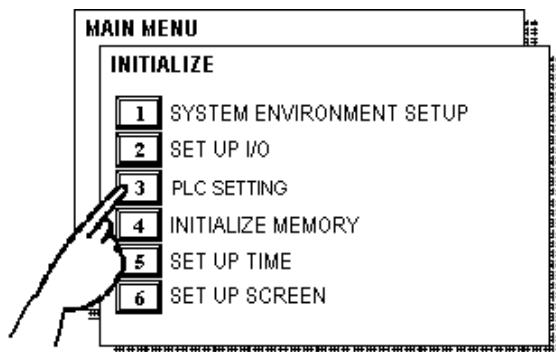

- ② Touch item #3, PLC SETTING. The PLC SETTING menu appears.

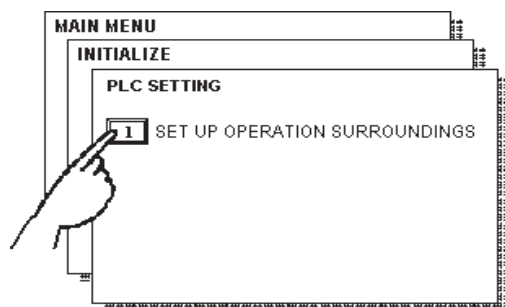

- ③ Touch item #1, SET UP OPERATION SURROUNDINGS. The SET UP OPERATION SURROUNDINGS menu will appear.

SET UP OPERATION SURROUNDINGS			
STARTING ADDRESS OF SYSTEM DATA AREA	[]		
UNIT NO.	[]		
SYSTEM AREA READING AREA SIZE (0-256)	[]		
RESET GP ON DATA WRITE ERROR		ON	OFF
<input type="checkbox"/> USE ADAPTER MODE/CPU DIRECT MODE	<input type="checkbox"/> ADAPTER	<input type="checkbox"/> CPU	<input type="checkbox"/> INSIDE

- ④ Touch the “USE ADAPTER MODE/CPU DIRECT MODE” selection. The selected item is highlighted.

GP77R Series Units

- ⑤ When using the 2 Port Adapter II (GP070-MD11), select the *ADAPTER* option. Select *CPU* when connecting CPU directly. When using the internal 2-Port feature, select *INSIDE* option.

2.2 Omron

2.2.1 System Structure

The following describes the system structure for connecting the GP to Omron PLCs.





Reference The Cable Diagrams mentioned in the following tables are listed in the section titled "2.2.2 Cable Diagrams".

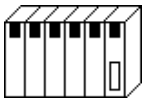

Important

If the PLC is used in RUN mode, "PLC COM. ERROR (02: 01)" may briefly display. The GP subsequently forces the PLC to enter the MONITOR mode (data can be written to the PLC, while it is in RUN mode); data communication will not be affected.

■ SYSMAC C Series (using Link I/F)

CPU	Link I/F	Cable Diagram	Cables	GP
	 Upper Link Unit			
C200H	C200H-LK201 ^{*1} C120-LK201-V1 ^{*2}	RS-232C (Cable Diagram 1)	Digital's GP410-IS00-O (5m)	GP Series
	C200H-LK202 ^{*1} C120-LK202-V1 ^{*2}	RS-422 (Cable Diagram 2)		
C200HS	C200H-LK201 ^{*1} C120-LK201-V1 ^{*2}	RS-232C (Cable Diagram 1)	Digital's GP410-IS00-O (5m)	
	C200H-LK202 ^{*1}	RS-422 (Cable Diagram 2)		
	CPU unit Link I/F ^{*3}	RS-232C (Cable Diagram 3)	Digital's GP000-IS03-MS (3m)	
C500, C500F, C1000H, C2000, C2000H	C120-LK201-V1 ^{*2}	RS-232C (Cable Diagram 1)	RS-232C Digital's GP410-IS00-O (5m)	
	C120-LK202-V1 ^{*2}	RS-422 (Cable Diagram 2)		
	C500-LK201-V1 ^{*1}	RS-232C (Cable Diagram 1) RS-422 (Cable Diagram 2)		
	C500-LK203 ^{*1}	RS-232C (Cable Diagram 1)		
C1000HF	C500-LK203 ^{*1}	RS-422(Cable Diagram 4)		
C20H, C28H, C40H	CPU unit Link I/F ^{*3}	RS-232C (Cable Diagram 5)		
C120, C120F	C120-LK201-V1 ^{*2}	RS-232C (Cable Diagram 1)	Digital's GP410-IS00-O (5m)	
	C120-LK202-V1 ^{*2}	RS-422 (Cable Diagram 2)		



* 1 Base installation type.

* 2 CPU installation type.

* 3 Connect to the RS-232C port.

CPU	Link I/F	Cable Diagram	Cables	GP
CQM1-CPU42	RS-232C Port on CPU unit	RS-232C (Cable Diagram 3)	Omron's RS-232C cable XW2Z-200S (2m) XW2Z-500S (5m) Digital's GP000-IS03-MS (3m)	GP Series
SRM1-C02 CPM2A	CPM1-CIF01	RS-232C (Cable Diagram 3)	Omron's RS-232C cable XW2Z-200S (2m) XW2Z-500S (5m) Digital's GP000-IS03-MS (3m)	
	RS-232C Port on CPU unit			
	CPM1-CIF11	RS-422 (Cable Diagram 9)		
CPM1-20CDR-A	CPM1-CIF01	RS-232C (Cable Diagram 3)	Omron's RS-232C cable XW2Z-200S (2m) XW2Z-500S (5m) Digital's GP000-IS03-MS (3m)	
	CPM1-CIF11	RS-422 (Cable Diagram 9)		
CQM1H-CPU21	RS-232C Port on CPU unit	RS-232C (Cable Diagram 3)	Omron's RS-232C cable XW2Z-200S (2m) XW2Z-500S (5m) Digital's GP000-IS03-MS (3m)	
CPM2C	Peripheral port on CP2C-CIF01	RS-232C	Omron's cable CS1W-CN114 and CQM1-CIF01 are required.	
	RS-232C port on CPM2C-CIF01	RS-232C (Cable Diagram 3)	Omron's RS-232C cable XW2Z-200S (2m) XW2Z-500S (5m) Digital's GP000-IS03-MS (3m)	

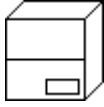
■ SYSMAC C Series (CPU Direct Connection)

CPU ^{*1}	Cables	GP
		
C 200HS, SRM1-C 02, CQM1-CPU11, CQM1-CPU42, CPM1-20CDR-A, CQM1H-CPU21 ^{*2} CPM2C ^{*2}	Omron Isolation Cable CQM1-CIF01	GP Series

* 1 Connect to a peripheral port.

*2 Omron's cable (CSIW-CN114) is required.





The CQM1-CPU11 has only one peripheral port, so a programming console cannot be used at the same time with the GP.



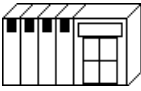
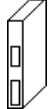

If power to CQM1 is turned OFF while it is connected to the GP, "RUN" (operation) will stop. To change CQM1 to RUN mode when the power is turned back ON, change the CQM1's [Power ON Operation Mode Setting] to [RUN].

■ SYSMAC-α Series (using Link I/F)

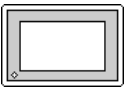

CPU	Link I/F	Cable Diagram	Cables	GP
	Communication board 			
C200HX-CPU85-Z C200HE-CPU64 C200HG-CPU44 C200HG-CPU42 C200HG-CPU63 C200HG-CPU43	C200HW-COM06	RS-232C (Cable Diagram 3) RS422 (Cable Diagram 6)	Omron's RS232C cable XW2Z-200S (2m) XW2Z-500S (5m) Digital's RS232C cable GP000-IS03-MS (3m)	GP Series
C200HE-CPU42-Z	RS-232C Port on CPU unit	RS-232C (Cable Diagram 3)	Omron's RS232C cable XW2Z-200S (2m) XW2Z-500S (5m) Digital's RS232C cable GP000-IS03-MS (3m)	
C200HX-CPU64-Z	C200H-LK202-V1	RS-422 (Cable Diagram 2)		
	C200H-LK201-V1	RS-232C (Cable Diagram 1)	Digital's RS232C cable GP410-IS00-0 (5m)	

■ SYSMAC CV Series (using Link I/F)

CPU	Link I/F	Cable Diagram	Cables	GP
	 Upper Link Unit			
CV500, CV1000, CVM1	CV500-LK201	RS-232C <SIO port 1 connection> (Cable Diagram 1) RS-232C <SIO port 2 connection> (Cable Diagram 7) RS422 <SIO port 2 connection> (Cable Diagram 8)	RS232C (SIO port 1 connection) Digital's GP410-IS00-O (5m)	GP Series
	CPU unit Link I/F *1	RS-232C (Cable Diagram 7) RS422 (Cable Diagram 8)		

*1 Connect to the Host Link Port

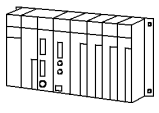
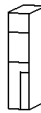
■ SYSMAC CS1 Series (1:1)

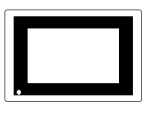
CPU	Link I/F	Cable Diagrams		GP
				
CS1H-CPU67 CS1H-CPU66 CS1H-CPU65 CS1H-CPU64 CS1H-CPU63 CS1G-CPU45 CS1G-CPU44 CS1G-CPU43 CS1G-CPU42	RS-232C port for CPU unit	RS-232C (Cable Diagram 3)	Digital's GP000-IS03-MS(3m) Omron's XW2Z-200S(2m) XW2Z-500S(5m)	GP Series
	Peripheral Port for CPU unit	RS-232C *1 (Cable Diagram 11)	Omron's CS1W-CN225 *1 CS1W-CN625 *1	
	CS1W-SCU21	RS-232C (Port 1,2) (Cable Diagram 3)	Digital's GP000-IS03-MS(3m)	
	CS1W-SCB21	RS-232C (Port 1,2) (Cable Diagram 3)	Omron's XW2Z-200S(2m) XW2Z-500S(5m)	
	CS1W-SCB41	RS-232C (Port 1) (Cable Diagram 3)		
		RS-422 (Port 2) (Cable Diagram 10)		

*1 When connecting to the peripheral port, a particular cable is needed between GP and the CS1W-CN*25 cable, refer to this section's Cable Diagram 11 for the required cable.

2.2.2 Cable Diagrams

The cable diagrams illustrated below and the cable diagrams recommended by Omron Corp. may differ; in any case, using these cables for your PLC operations will not cause any problems.



Ground your PLC's FG terminal according to your country's applicable standard. For details, refer to the corresponding PLC manual.



- **Connect the FG line of the Shield cable to either the GP or PLC, depending on your environment. When using a connector hood and grounding the FG line, be sure to use an electrical conductor.**
- **For the RS-232C connection, use a cable length less than 15m.**

Cable Diagram 1 (RS-232C)

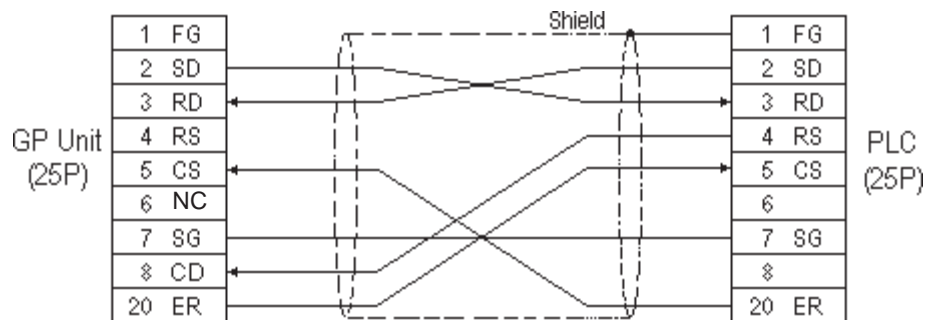

Cable Diagram 2 (RS-422)



- Turn on the Termination Resistor switch, on the PLC.
- Signals A and B are opposite on the GP and PLC.

- When using Digital's RS-422 connector terminal adapter GP070-CN10-0

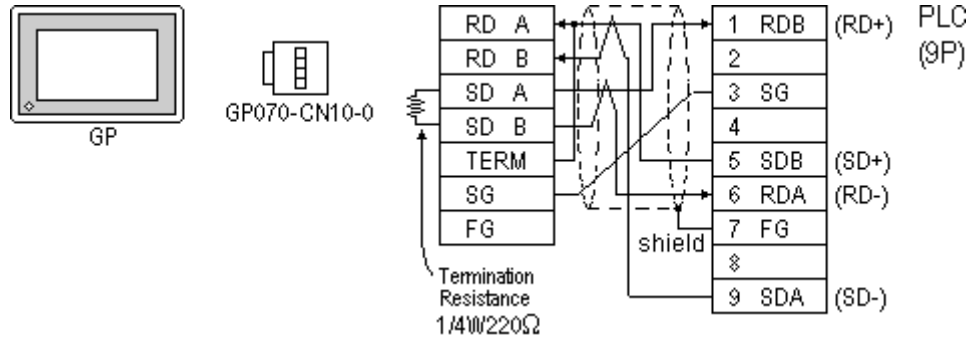

- When using Digital's RS-422 Cable, GP230-IS11-0

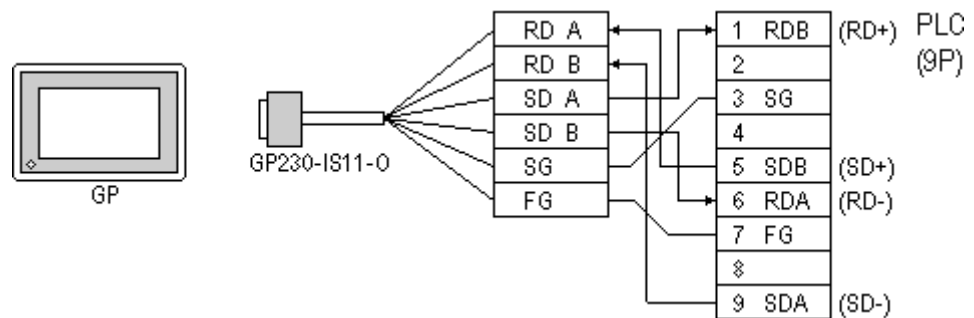

- When making your own cable connections

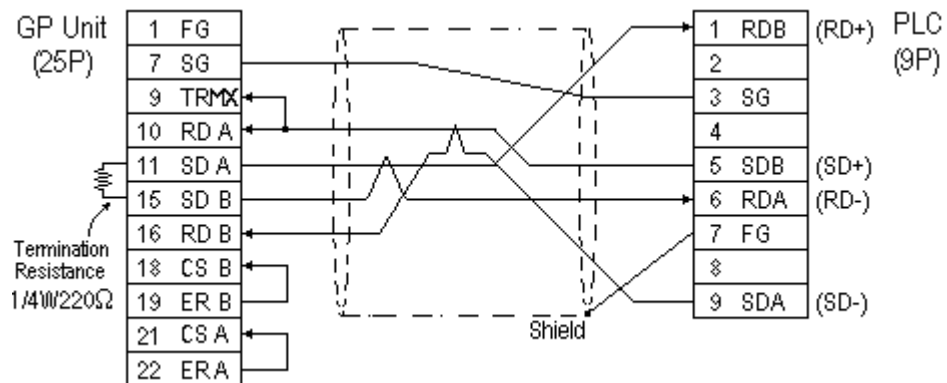



Note: When making your own cable connections, we recommend using Hiramawa Densen's H-9293A (CO-HC-ESV-3P*7/0.2) cable.



- When connecting the #9 and #10 pins in the GP Serial I/F, a termination resistance of 100Ω is added between RDA and RDB.
- If a shielded cable is connected to the RS-422 port, it must be no longer than 500 meters.
- If a communications cable is used, it must be connected to the SG (signal ground).

Cable Diagram 3 (RS-232C)

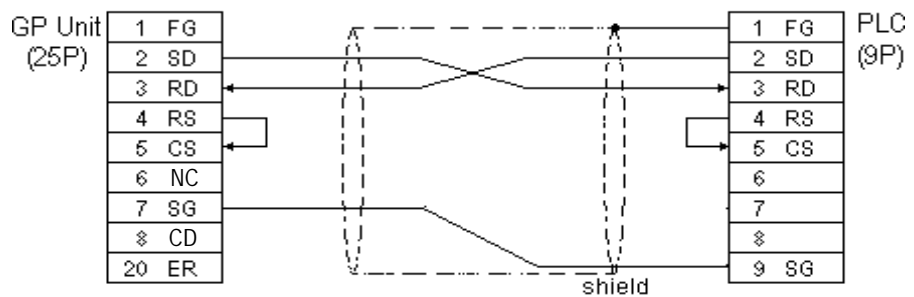

Note: While the above connection diagram will differ slightly from the Omron XW2Z-200S (2m) and XW2Z-500S (5m) RS-232C cables, the system will operate smoothly using this design.

Cable Diagram 4 (RS-422)



- Turn the PLC's Termination Resistor switch ON.
- Signals A and B are opposite on the GP and PLC.

- When using Digital's RS-422 connector terminal adapter GP070-CN10-0

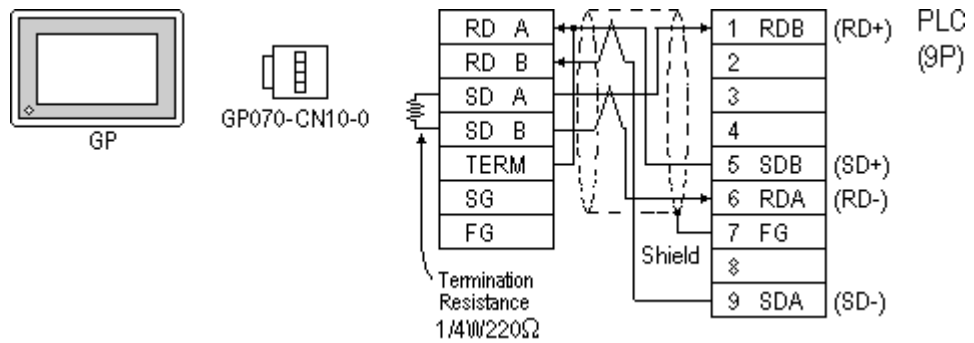

- When using Digital's RS-422 Cable, GP230-IS11-0

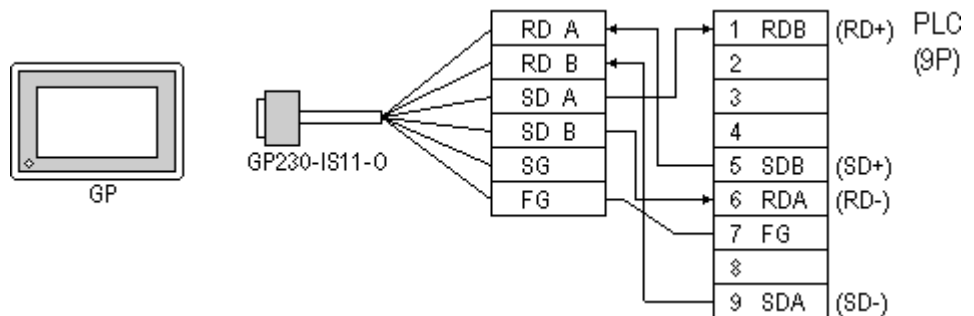

- When making your own cable connections

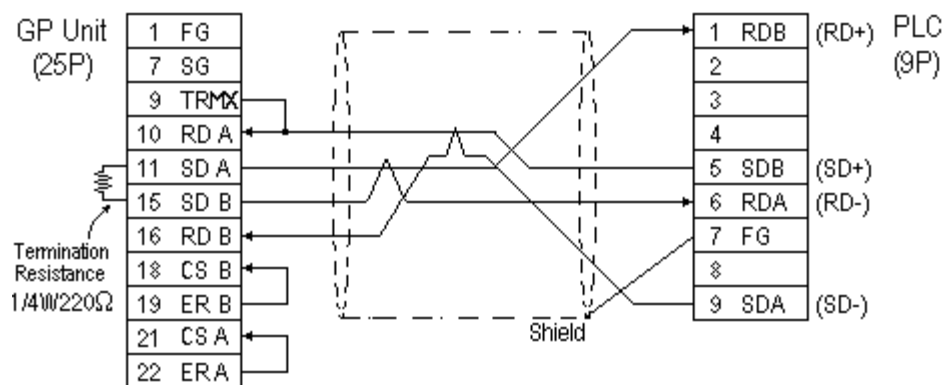

- When making your own cable connections, we recommend using Hirakawa Densen's H-9293A (CO-HC-ESV-3P*7/0.2) cable.
- When connecting the #9 and #10 pins in the GP Serial I/F, a termination resistance of 100Ω is added between RDA and RDB.

Cable Diagram 5 (RS-232C)

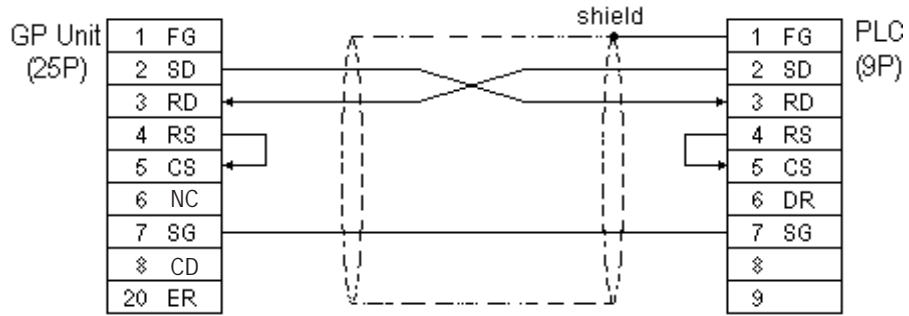

Hirakawa Densen's H-9293A (CO-HC-ESV-3P*7/0.2) cable is recommended as the connection cable.

Cable Diagram 6 (RS-422)



- Turn on the Termination Resistor switch, on the PLC side.
- Signals A and B are opposite on the GP and PLC.
- The connector and the connector hood, listed below, are included with the Communication board.

Connector XW2A-0901

Connector Hood XW2S-0901

- When using Digital's RS-422 connector terminal adapter GP070-CN10-0

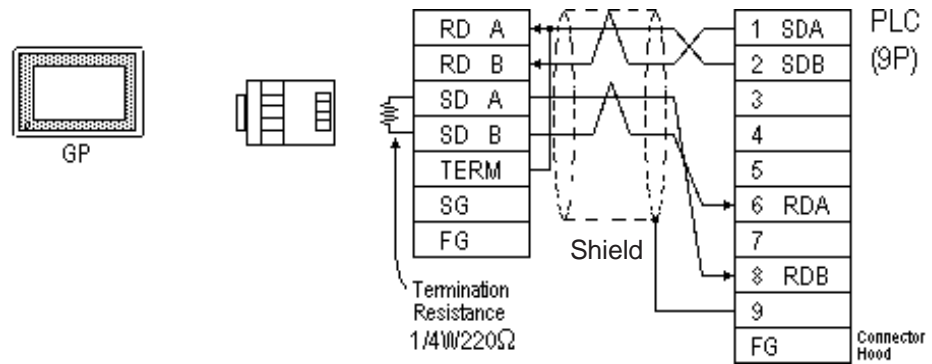

- When using Digital's RS-422 connector terminal adapter GP230-IS11-0

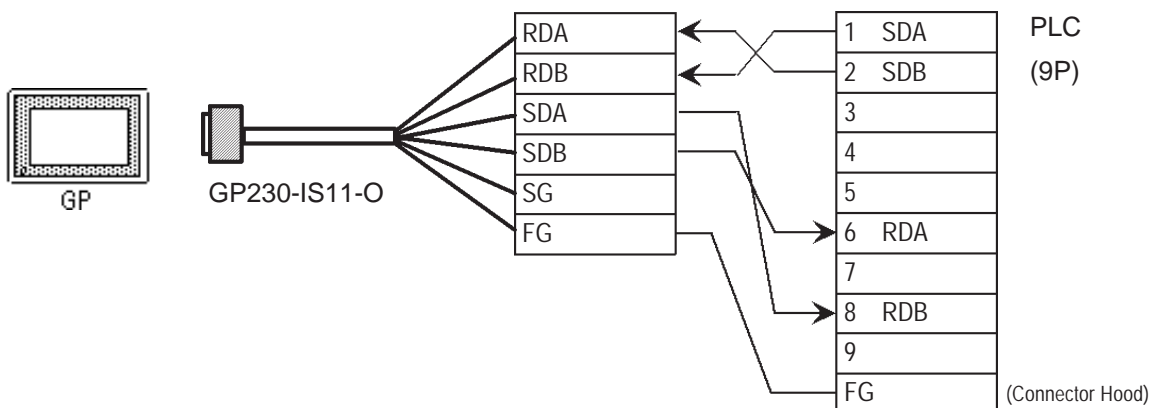

- When making your own cable connections

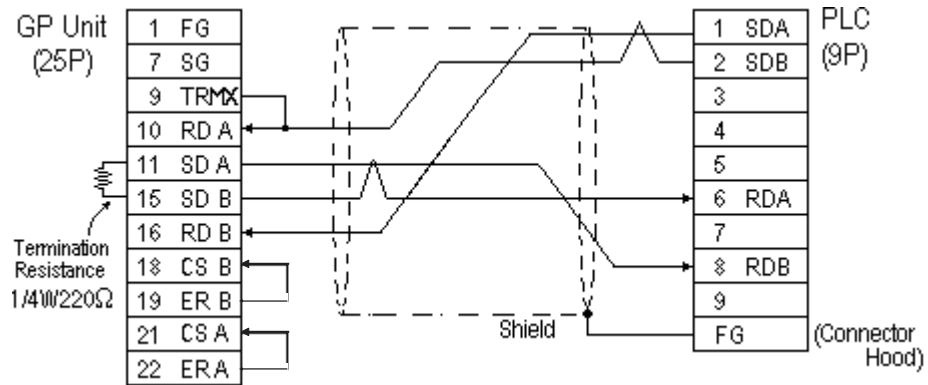

- When making your own cable connections, we recommend using Hirakawa Densen's H-9293A (CO-HC-ESV-3P*7/0.2) cable.
- When connecting the #9 and #10 pins in the GP Serial I/F, a termination resistance of 100Ω is added between RDA and RDB.

Cable Diagram 7 (RS-232C)

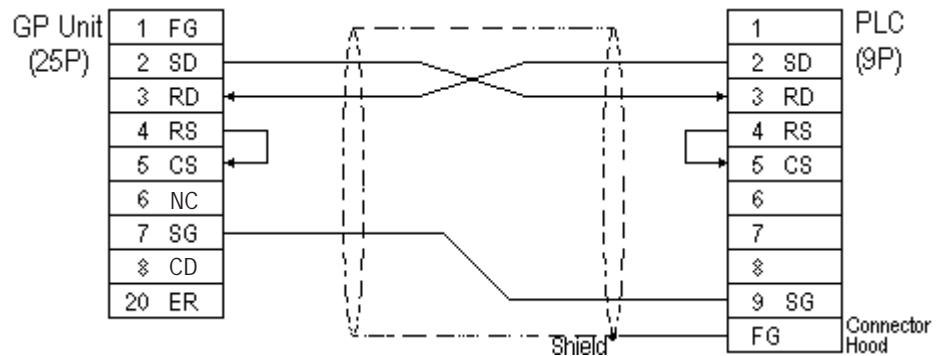

- One each of the connector and connector hood, listed below, are included with the CV500/CV1000 CPU unit. Only these connectors listed below can be used.

Connector XM2A-0901

Connector Hood XM2S-0911

- Hirakawa Densen's H-9293A (CO-HC-ESV-3P*7/0.2) cable is recommended as the connection cable.

Cable Diagram 8 (RS-422)



- Setup the PLC's RS-232C/RS-422 toggle switch to RS-422.
- Turn on the Termination Resistor switch, on the PLC side.
- Signals A and B are opposite on the GP and PLC
- The connector and connector hood, listed below, are included with the CV500/CV1000 CPU unit. Only these connectors can be used.

1 Connector XM2A-0901

1 Connector Hood XM2S-0911

- When using Digital's RS-422 connector terminal adapter GP070-CN10-0

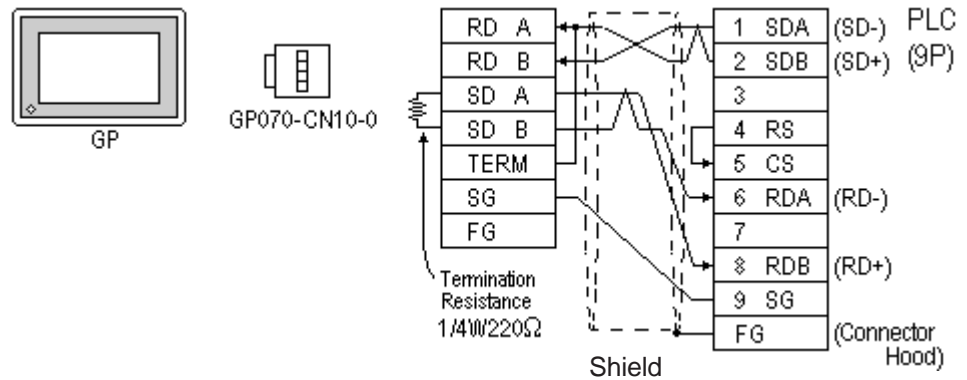

- When using Digital's RS-422 Cable, GP230-IS11-0

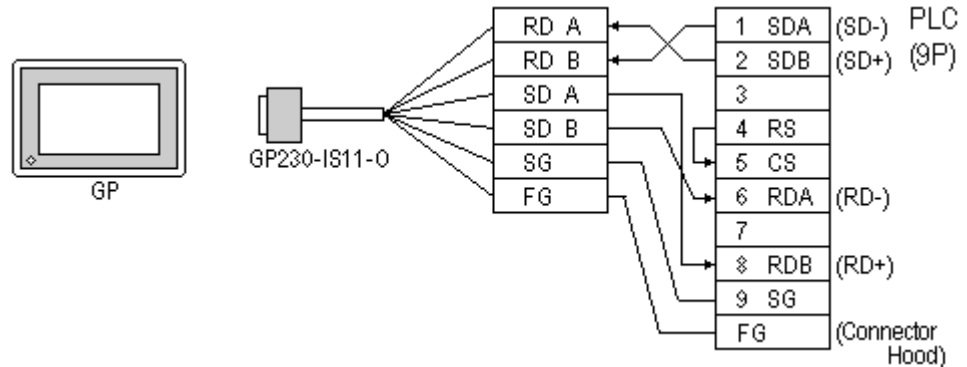

- When making your own cable connections

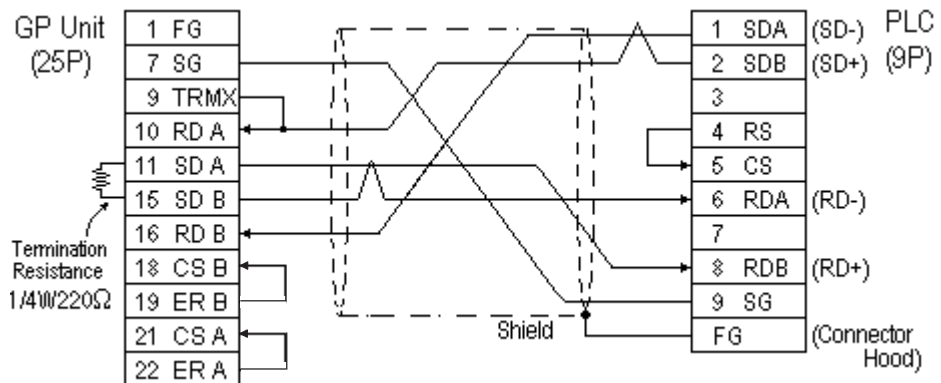



- When making your own cable connections, we recommend using Hirakawa Densen's H-9293A (CO-HC-ESV-3P*7/0.2) cable.
- When connecting the #9 and #10 pins in the GP Serial I/F, a termination resistance of 100Ω is added between RDA and RDB.

Cable Diagram 9 (RS-422)

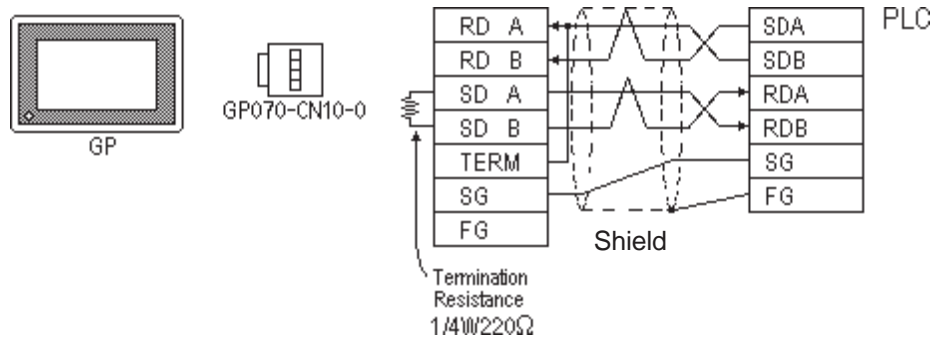

- When using Digital's RS-422 connector terminal adapter GP230-IS11-0

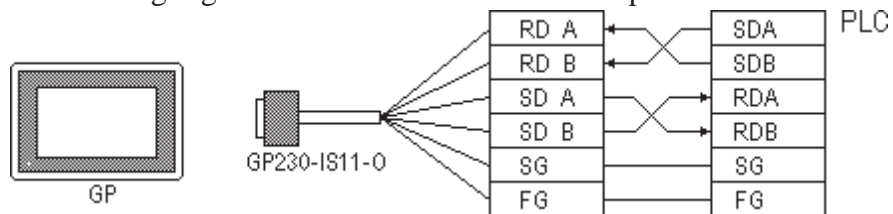

- When making your own cable connections

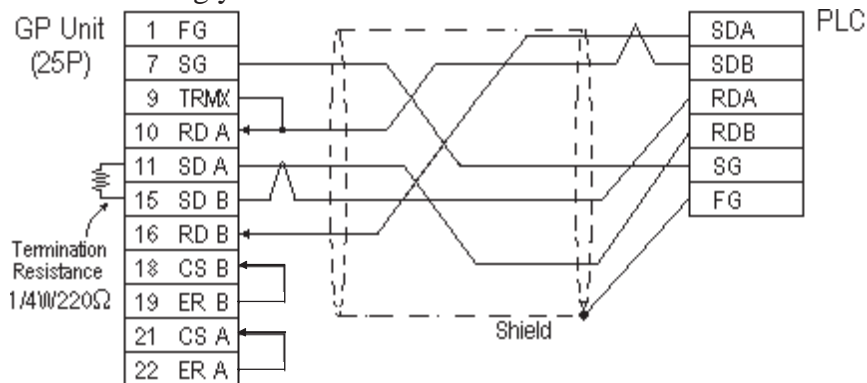

Cable Diagram 10 (RS-422)

- When using Digital's RS-422 connector terminal adapter GP070-CN10-O

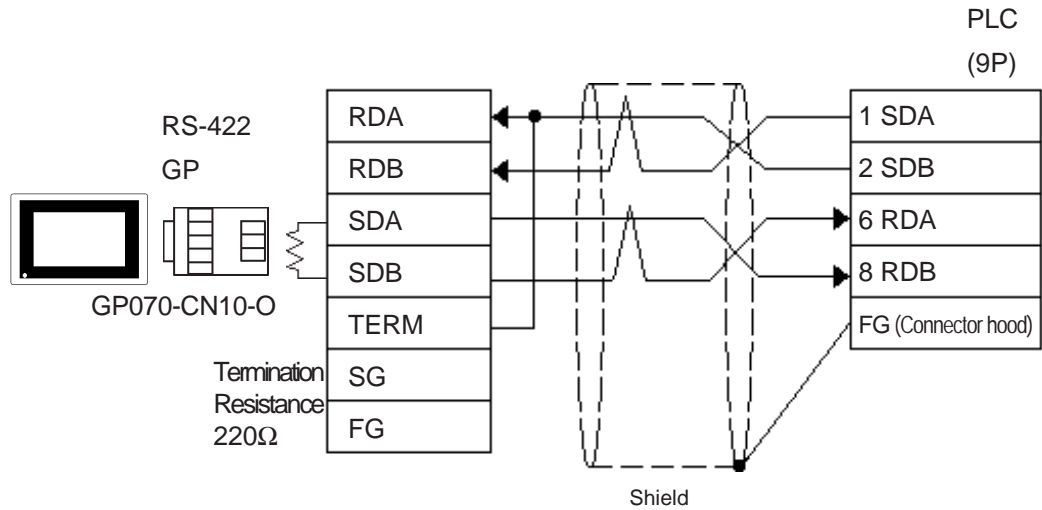

- When making your own cable connection

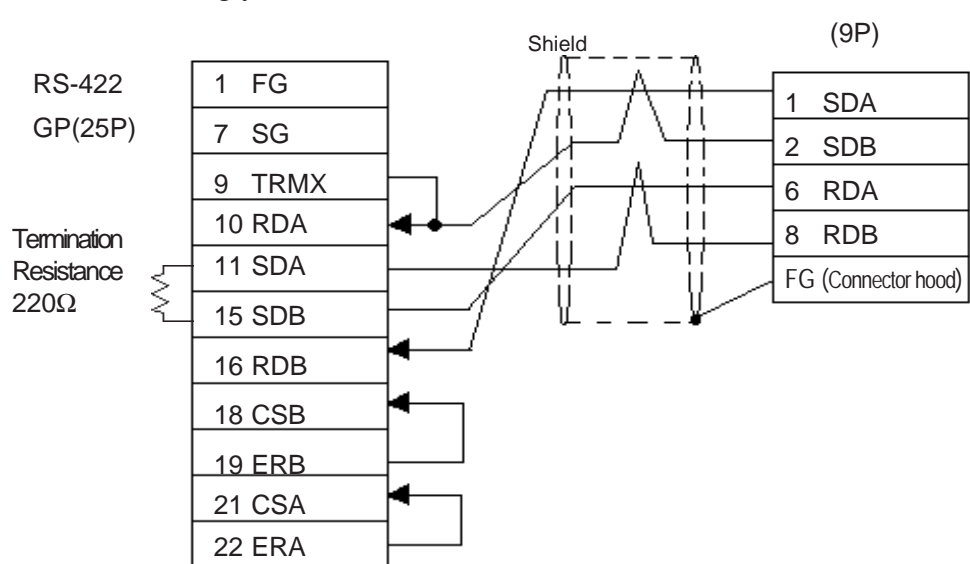

- Turn ON the PLC's termination resistance switch.
- When connecting the #9 and #10 pins in the GP Serial I/F, a termination resistance of 100Ω is added between RDA and RDB.
- Be aware the A and B signals of the GP and PLC are opposite to each other.
- The cable length must be 500 meters or less.
- The Hiraga Hutech's CO-HC-ESV-3PX7/0.2 cable is recommended for this connection.

Cable Diagram 11 (RS-232C)

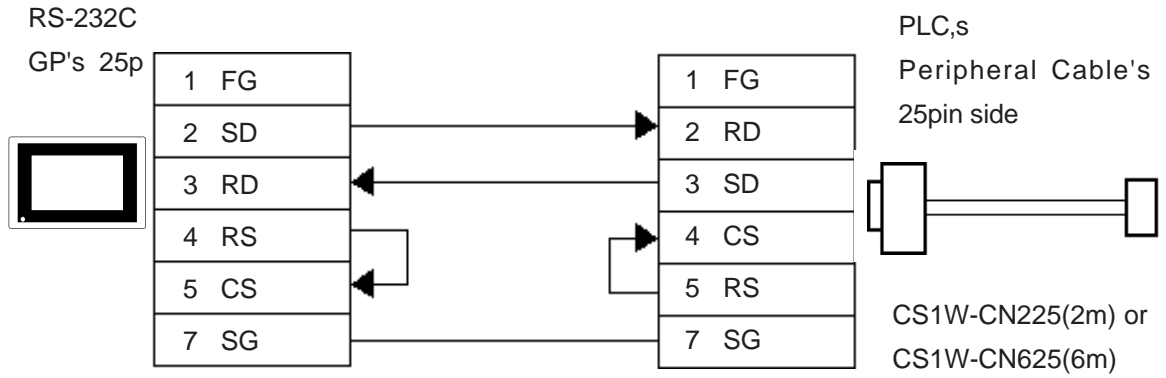

2.2.3 Supported Devices

The following describes the range of devices supported by the GP.

■ SYSMAC C Series

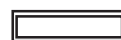

Setup System Area here.

Device	Bit Address	Word Address	Particulars	
I/O Relay	00000 ~ 51115	000 ~ 511	*1	
Internal Hold Relay				
Special Hold Relay				
Analog Setup Value Storage Area	22000 ~ 22315	220 ~ 223	*2	
Data Link Relay	LR0000 ~ LR6315	LR00 ~ LR63	L/H	
Auxiliary Memory Relay	AR0000 ~ AR2715	AR00 ~ AR27		
Latch Relay	HR0000 ~ HR9915	HR00 ~ HR99		
Timer (contact)	TIM000 ~ TIM511	---		
Counter (contact)	CNT000 ~ CNT511	---		
Timer (current value)	---	TIM000 ~ TIM511		
Counter (current value)	---	CNT000 ~ CNT511		
Data Memory	---	DM0000 ~ DM9999		

* 1 Depending on the CPU, differ the range of each supported device and the possibility of Data write. Before using, refer to each CPU User Manual.

* 2 Can only be used by CQM1-CPU42.



- The method of writing bits will differ depending on the GP series.

<GP-*30 series>

When the bit write operation (other than *Reverse*) is performed, the corresponding word address will set the bits to 0 (except the designated bits).

<Except GP-*30 series>

When the bit write operation is performed, the GP reads the PLC's corresponding word address and turns a bit ON, then send back to PLC. Do not write to the word address from the ladder program in the middle of this operation.

- When running a GP-*30 Series ladder program, be aware of the above points.

■ SYSMAC-α Series

 Setup System Area here.

Device	Bit Address	Word Address	Particulars	
I/O Relay I	00000 ~ 02915	000 ~ 029	L/H	
I/O Relay II	30000 ~ 30915	300 ~ 309		
Internal Hold Relay I	03000 ~ 23515	030 ~ 235		
Internal Hold Relay II	31000 ~ 51115	310 ~ 511		
Special Hold Relay I	23600 ~ 25507	236 ~ 255		
Special Hold Relay II	25600 ~ 29915	256 ~ 299		
Latch Relay	HR0000 ~ HR9915	HR00 ~ HR99		
Auxiliary Memory Relay	AR0000 ~ AR2715	AR00 ~ AR27		
Link Relay	LR0000 ~ LR6315	LR00 ~ LR63		
Timer (contact)	TIM000 ~ TIM511	---		
Counter (contact)	CNT000 ~ CNT511	---		
Timer (current value)	---	TIM000 ~ TIM511		
Counter (current value)	---	CNT000 ~ CNT511		
Data Memory	---	DM0000 ~ DM6655		Bit 5



- The method of writing bits will differ depending on the GP series.

<GP-*30 series>

When the bit write operation (other than *Reverse*) is performed, the corresponding word address will set the bits to 0 (except the designated bits).

<Except GP-*30 series>

When the bit write operation is performed, the GP reads the PLC's corresponding word address and turns a bit ON, then send back to PLC. Do not write to the word address from the ladder program in the middle of this operation.

- When running a GP-*30 Series ladder program, be aware of the above points.

◆ SYSMAC C or α series communications mode selection

When using the SYSMAC C or α series with the GP in OFFLINE mode, either mode 2 or mode 1 can be selected during the entry of the initial settings. Be aware you cannot designate this settings from GP-PRO/PBIII for Windows.

- Mode 2: This is a newly added communications mode. This mode is enabled when less than 64 devices have been designated by a single screen's tags. The communications speed has been improved. Select this mode when using less than 64 devices.

- Mode 1: A communications mode equivalent to the old one. This mode is valid for 64 or more devices have been specified by a single screen's tags. The communications speed has been improved. Select this mode when using 64 or more devices.



- **If the on-screen data memory area in the GP is initialized or if the on-screen data is transferred from the drawing software, the GP returns to mode 1 (its initial setting). Use the offline settings area to select mode 2.**
- **In mode 2, the communications speed may not always be improved depending on which tags and system area are used, as well as how the read areas are allocated.**

■ SYSMAC-CV Series

Setup System Area here.

Device	Bit Address	Word Address	Particulars
I/O Relay I	00000 ~ 19915	000 ~ 199	L/H
Internal Hold Relay			
Sysmac BUS/2 Remote I/O Relay	020000 ~ 099915	0200 ~ 0999	
Data Link Relay	100000 ~ 119915	1000 ~ 1199	
Special Hold Relay	A00000 ~ A51115	A000 ~ A511	
Latch Relay	120000 ~ 149915	1200 ~ 1499	
Internal Aux. Relay	190000 ~ 229915	1900 ~ 2299	
SYSBUS Remote I/O Relay	230000 ~ 255515	2300 ~ 2555	
Timer (contact)	T0000 ~ T1023	---	
Counter (contact)	C0000 ~ C1023	---	
Timer (current value)	---	T0000 ~ T1023	
Conter (current value)	---	C0000 ~ C1023	
Data Memory	---	D0000 ~ D9999	<input type="text" value="Bit 5"/>



- Write operations cannot be performed on the *Timer* and *Counter* bit devices.
- The method of writing bits will differ depending on the GP series.
<GP-*30 series>

When the bit write operation (other than *Reverse*) is performed, the corresponding word address will set the bits to 0 (except the designated bits).

<Except GP-*30 series>

When the bit write operation is performed, the GP reads the PLC's corresponding word address and turns a bit ON, then send back to PLC. Do not write to the word address from the ladder program in the middle of this operation.

- When running a GP-*30 Series ladder program, be aware of the above points.

■ SYSMAC CS1 Series

In this list, "Exp." means "Expansion".

 Setup system area here.

Device	Bit Address	Word Address	Particulars
Channel I/O	C1000000 ~ C10614315	C100000 ~ C106143	
Internal Auxiliary Relay	W00000 ~ W51115	W000 ~ W511	
Hold Relay	H00000 ~ H51115	H000 ~ H511	
Special Auxiliary Relay	A00000 ~ A95915	A000 ~ A959	*1
Timer(Contact)	T0000 ~ T4095	----	*3
Counter(Contact)	C0000 ~ C4095	----	*3
Timer(Current)	----	T0000 ~ T4095	
Counter(Current)	----	C0000 ~ C4095	
Data Memory	D0000000 ~ D3276715	D00000 ~ D32767	*2
Exp. Data Memory (E0 ~ EC)	E0000000 ~ EC3276715	E000000 ~ EC32767	*4
Exp. Data Memory (Current Bank)	----	EM00000 ~ EM32767	Bit 15
Task Flag	----	TK0 ~ TK30	2 Bit 15 *3
Index Register	----	IR0 ~ IR15	Bit 31 *3
Data Register	----	DR0 ~ DR15	Bit 15 *3

*1 Addresses A000 to A477 cannot be written to.

*2 When using the Communication Unit (CS1W-SCU21), addresses D30000 to D31599, since they are used for PLC system settings, should not be written to from the GP.

When using the Communication Board (CS1W-SCB21/41), addresses D32000 to D32767 are used for PLC settings, should not be written to from the GP.

*3 Cannot be written to.

*4 The range of Expansion Data Memory varies depending on the CPU type.

Reference For details about each device, refer to Omron's SYSMAC CS1 Series Communication Board CS1W-SCB21-/41 Communication CS1W-SCU21 Users Manual.

2.2.4 Environment Setup

The following lists Digital's recommended PLC and GP communication settings.

■ SYSMAC C Series

GP Setup		Upper Link Unit Setup	
Baud Rate	19200 bps	Baud Rate	19200 bps
Data Length	7 bits	Data Bit	7 bits
Stop Bit	2 bits	Stop Bit	2 bits
Parity Bit	Even	Parity Bit	Even
Data Flow Control	ER Control	---	
Communication Format (RS-232C)	RS-232C	Communication Format ^{*1} (RS-232C)	RS-232C
Communication Format (RS-422)	4-wire type	Communication Format ^{*1} (RS422)	RS-422
---		Command Level ^{*1}	Level 1,2,3 is valid
---		Relation ^{*1}	1:N
---		DC +5V power supply ^{*1}	No
---		CTS Setup ^{*1}	Normally On
---		Mode Setup ^{*2}	Upper Link
---		Communication Conditions Setting Switch ^{*3}	OFF
---		Communication Port Function Setting Switch ^{*4}	SW1:OFF SW2:ON
Unit No.	0	Station Number	0

*1 This setup is unavailable for the RS-232C port of C200HS, CQM1 and CPH2A.

*2 This setup is available only for the RS-232C port of C200HS and CQM1.

*3 This setup is available only for CPM2A.

*4 This setup is available only for CPM2C.

■ SYSMAC-α Series (using Communication board)

GP Setup		Communication board Setup	
Baud Rate	19200 bps	Baud Rate	19200 bps
Data Length	7 bits	Data Bit	7 bits
Stop Bit	2 bits	Stop Bit	2 bits
Parity Bit	Even	Parity Bit	Even
Data Flow Control	ER Control	---	
Communication Format (RS-232C)	RS-232C	---	
Communication Format (RS-422)	4-wire type	RS-422/485 cable (2-wire/4-wire type) switching setting (dip switch 1)	4
Unit No.	0	Station Number	0



When using the above list's recommended settings, please perform the following.

Port A: Store "0001" in DM6555, and store "0304"<HEX> in DM6556.

Port B: Store "0001" in DM6550, and store "0304"<HEX> in DM6551.

■ **SYSMAC-α Series** (when using the CPU’s RS-232C port)

GP Setup		RS-232C port Setup	
Baud Rate	19200 bps	Baud Rate	19200 bps
Data Length	7 bits	Data Bit	7 bits
Stop Bit	2 bits	Stop Bit	2 bits
Parity Bit	Even	Parity Bit	Even
Data Flow Control	ER Control	---	
Communication Format	RS-232C	Using Mode	Host (PLC) Link
Unit No.	0	Station Number	0



When using the above list’s recommended settings, please follow the instructions given here.
CPU 232C Port: Store “0001” in DM6645, and store “0304” <HEX> in DM6646.

■ **SYSMAC CV Series**

GP Setup		Upper Link Unit Setup	
Baud Rate	19200 bps	Baud Rate	19200 bps
Data Length	7 bits	Data Bit	7 bits
Stop Bit	2 bits	Stop Bit	2 bits
Parity Bit	Even	Parity Bit	Even
Data Flow Control	ER Control	---	
Communication Format (RS-232C)	RS-232C	Communication Format (RS-232C)	RS-232C
Communication Format (RS-422)	4-wire type	Communication Format (RS-422)	RS-422
Unit No.	0 ^{*1}	Station Number	0 ^{*1}

* 1 When GP is connected to the Port 1 on the Upper Link Unit CV500-LK201, the station number must be fixed as "0". (The station number cannot be set on the PLC.)

■ **SYSMAC CS1 Series <CPU unit's RS-232C Port>**

GP Setup		PLC Setup	
Baud Rate	19200	Baud Rate	19200
Data Length	7	Data Length	7
Stop Bit	2	Stop Bit	2
Parity Bit	Even	Parity Bit	Even
Data Flow Control	ER	_____	_____
Communication Format	RS232C	_____	_____
Unit No.	0	Station No.	0
_____	_____	Dip Switch	SW1: OFF SW5: OFF SW7: OFF SW8: OFF
_____	_____	Mode Setup	Upper Link

■ **SYSMAC CS1 Series <CPU unit's Peripheral Port>**

GP Setup		PLC Setup	
Baud Rate	19200	Baud Rate	19200
Data Length	7	Data Length	7
Stop Bit	2	Stop Bit	2
Parity Bit	Even	Parity Bit	Even
Data Flow Control	ER	_____	_____
Communication Format	RS232C	_____	_____
Unit No.	0	Station No.	0
_____	_____	Dip Switch	SW1: OFF SW4: ON SW7: OFF SW8: OFF
_____	_____	Mode Setup	Upper Link

■ **SYSMAC CS1 Series**

< **When using the Communication Board /Unit**>

GP Setup		PLC Setup	
Baud Rate	19200	Baud Rate	19200
Data Length	7	Data Length	7
Stop Bit	2	Stop Bit	2
Parity Bit	Even	Parity Bit	Even
Data Flow Control	ER	_____	_____
Communication Format (using RS232C)	RS232C	_____	_____
Communication Format (using RS422)	4-wire type	WIRE (2-wire/4-wire type Switch)	4-wire type
		TERM (Termination Resistance Switch)	Termination Resistance ON
Unit.No	0	Upper Link Station No.	0
_____	_____	Serial Communication mode	Upper Link
_____	_____	Communication Delay Time	0
_____	_____	CTS Control	None





2.3 Fuji Electric

2.3.1 System Structure

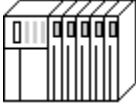

The following describes the system structure for connecting the GP to Fuji Electric Corporation, Ltd. PLCs.

Reference Cable Diagrams mentioned in the following tables are listed in the section titled "2.3.2 Cable Diagrams".

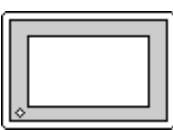

■ MICREX-F Series (using Link I/F)

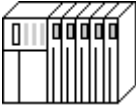
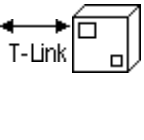
CPU	Link I/F	Cable Diagram	Cables	GP
	 PC I/F Module/ Generic I/F			
F80H, F120H, F250	FFU-120B PC Interface Module	RS-232C (Cable Diagram 1) RS-422 (Cable Diagram 2)	RS-232C Digital's GP410-IS00-O (5m)	GP Series
F70S (NC1P-S0)	NC1L-RS2 (Generic Interface)	RS-232C (Cable Diagram 1)	Digital's GP410-IS00-O (5m)	

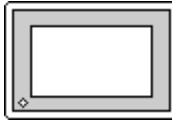

■ MICREX-F Series <T-link> (using Link I/F)

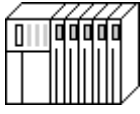
CPU	Link I/F	Cable Diagram	Cables	GP
	 T-Link PC Interface Module			
F80H, F120H, F250	FFK120A-C10	RS-232C (Cable Diagram 1)	RS-232C Digital's GP410-IS00-O (5m)	GP Series
F30, F50, F60, F80, F81, F120		RS-422 (Cable Diagram 2)		
F120S, F200	FFK100A-C10	RS-232C (Cable Diagram 3)		

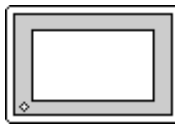
■ MICREX-F Series (FLT-ASFK) (CPU Direct Connection)

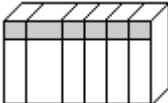

CPU	Adapter	Cable Diagram	Cables	GP
	PC Loader adapter 			
F80H, F250	Fuji Electric's FLT-ASFK	RS-232C (Cable Diagram 1)	RS-232C Digital's GP410-IS00-O	GP Series

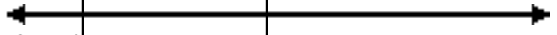
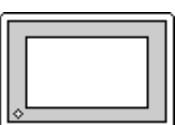
■ FLEX-PC Series (using Link I/F)

CPU	Link I/F	Cable Diagram	Cables	GP
	 General SIO Unit/ General I/F Module			
NB1, NB2, NB3	NB-RS1-AC (Generic RS-232C/ 485 SIO unit)	RS-232C (Cable Diagram 1) RS-422 (Cable Diagram 2)	RS-232C Digital's GP410-IS00-O (5m)	GP Series
NJ	NJ-RS2 (Generic RS-232C SIO interface module)	RS-232C (Cable Diagram 1)	Digital's GP410-IS00-O (5m)	
	NJ-RS2 (Generic RS-485 SIO interface module)	RS-422 (Cable Diagram 2)		
NS	NS-RS1 (Generic RS-232C/485 interface module)	RS-232C (Cable Diagram 1) RS-422 (Cable Diagram 2)	RS-232C Digital's GP410-IS00-O (5m)	

Note: Places noted as RS-422 can also use RS-485 on the PLC side.

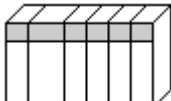
■ FLEX-PC Series (CPU Direct Connection)

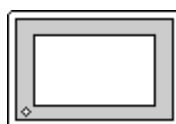
CPU	Cable Diagram	GP
		
NB1, NB2, NB3, NJ, NS	RS-422 (Cable Diagram 4)	GP Series

Note: When using Digital's T-Link I/F Unit, refer to the GP-*50/70 Series T-Link I/F Unit User's Manual.

2.3.2 Cable Diagrams

The cable diagrams illustrated below and the cable diagrams recommended by Fuji Electric Co., Ltd. may differ; in any case, using these cables for your PLC operations will not cause any problems.



Ground your PLC's FG terminal according to your country's applicable standard. For details, refer to the corresponding PLC manual.



- **Connect the FG line of the Shield cable to either the GP or PLC, depending on your environment. When using a connector hood and grounding the FG line, be sure to use an electrical conductor.**
- **For the RS-232C connection, use a cable length less than 15m.**
- **If a communications cable is used, it must be connected to the SG (signal ground).**

Cable Diagram 1 (RS-232C)

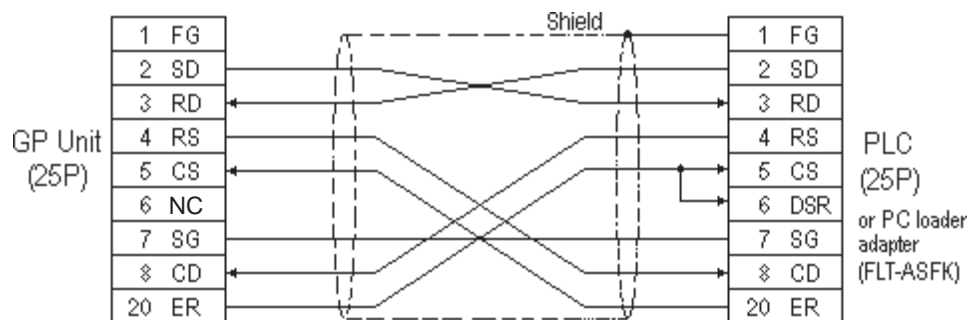

Cable Diagram 2 (RS-422)



Turn on the Termination Resistor switch, on the PLC side.

- When using Digital's RS-422 connector terminal adapter GP070-CN10-0

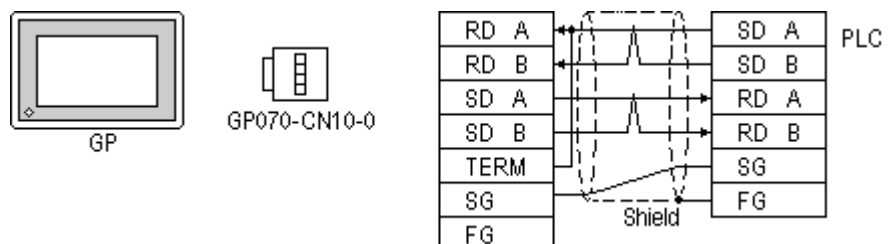

- When using Digital's RS-422 Cable, GP230-IS11-0

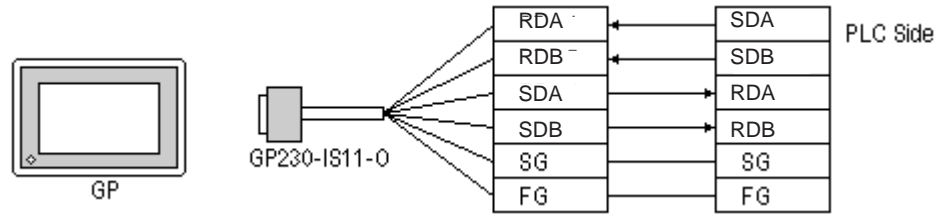

- When making your own cable connections

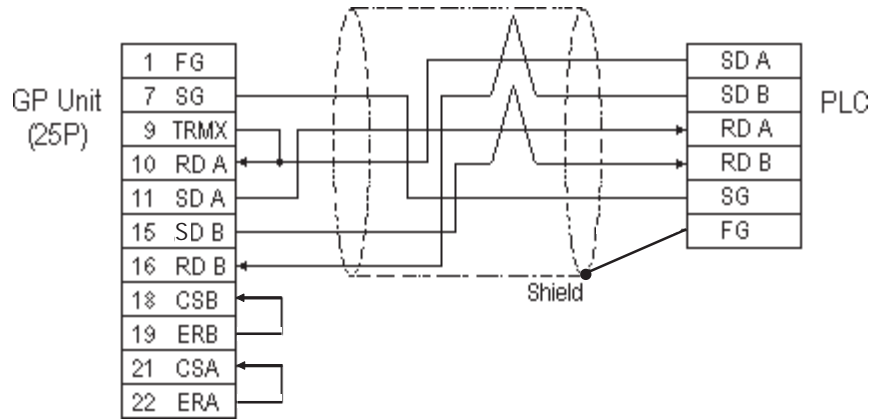

- When making your own cable connections, we recommend using Hitachi Densen's CO-SPEV-SB(A)3P*0.5S cable.
- When connecting the #9 and #10 pins in the GP Serial I/F, a termination resistance of 100Ω is added between RDA and RDB.

Cable Diagram 3 (RS-232C)

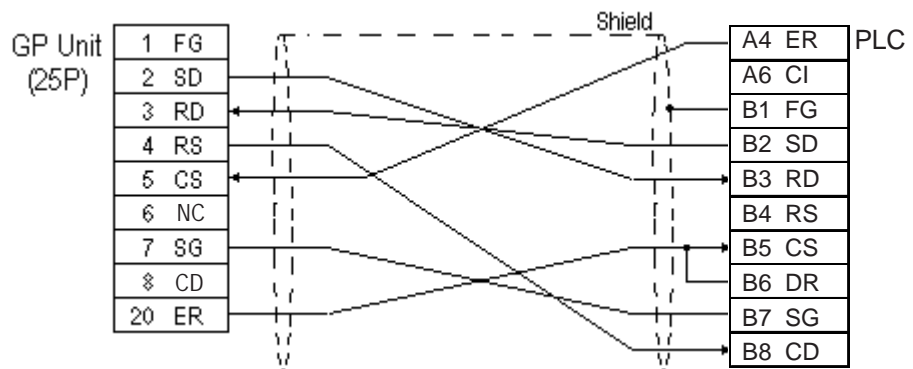

Cable Diagram 4 (RS-422)

Note:

For the PLC side connector (modular-jack) you can use Hirose's TM11P-88P.

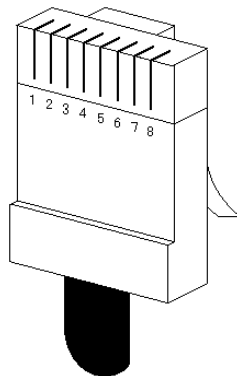

The pin numbers of the modular-jack for the connection diagrams below are based on the order described in the figure at the left.

- When using Digital's RS-422 connector terminal adapter GP070-CN10-0

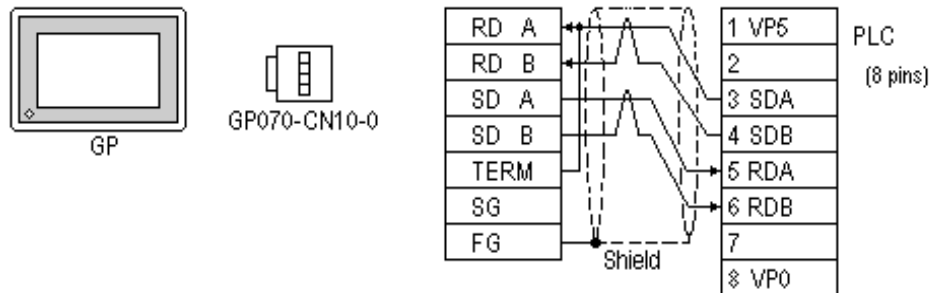

- When using Digital's RS-422 Cable, GP230-IS11-0

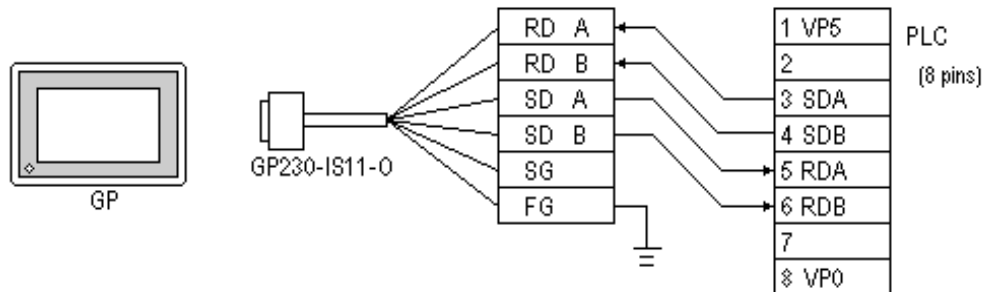

- When making your own cable connections

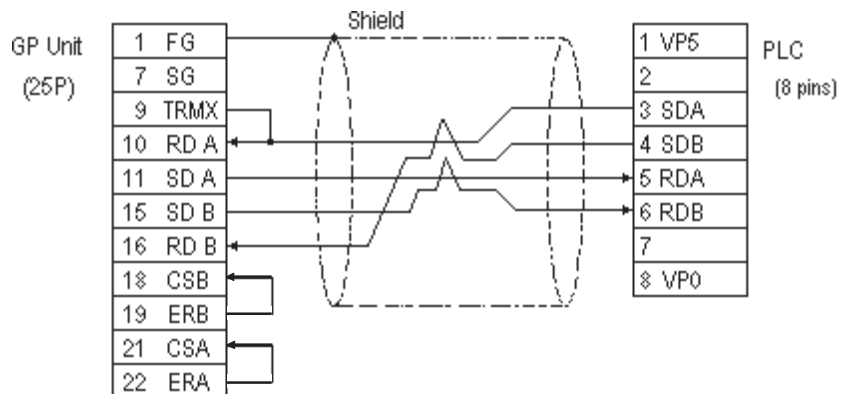

Note:

When connecting the #9 and #10 pins in the GP Serial I/F, a termination resistance of 100Ω is added between RDA and RDB.

2.3.3 Supported Devices

The following describes the range of devices supported by the GP.

■ MICREX-F Series

Setup System Area here.

Device	Bit Address	Word Address	Particulars
I/O Relay	B0000 ~ B511F	WB0000 ~ WB0511	*1
Direct I/O	---	W24.0000 ~ W24.0159	
Auxiliary Relay	M0000 ~ M511F	WM0000 ~ WM0511	*1
Keep Relay	K0000 ~ K063F	WK000 ~ WK063	*1
Differential Relay	D0000 ~ D063F	WD000 ~ WD063	*1 *4
Link Relay	L0000 ~ L511F	WL000 ~ WL0511	*1
Special Relay	F00000 ~ F4095F	WF0000 ~ WF4095	*1 *4
Announce Relay	A00000 ~ A4095F	WA0000 ~ WA4095	*1 *4
Timer 0.01 sec	T0000 ~ T0511	---	
Timer 0.1 sec	T0512 ~ T1023	---	
Counter	C 0000 ~ C 0255	---	
Timer 0.01 sec (current value)	---	TR0000 ~ TR0511	
Timer 0.01 sec (setup value)	---	TS0000 ~ TS0511	
Timer 0.1 sec (current value)	---	W9.000 ~ W9.511	
Counter (current value)	---	CR0000 ~ CR0255	
Counter (setup value)	---	CS0000 ~ CS0255	
Data Memory	---	BD0000 ~ BD4095	Bit 31
	---	DI0000 ~ DI4095	Bit 31
	---	SI0000 ~ SI4095	Bit 15
File Memory	---	W30.0000 ~ W30.4094	Bit 15 *2
	---	W31.0000 ~ W31.4094	Bit 15 *2
	---	W32.0000 ~ W32.4094	Bit 15 *2
	---	W33.0000 ~ W33.4094	Bit 31 *3
	---	W34.0000 ~ W34.4094	Bit 31 *3

H/L

* 1 The MSB (most significant bit) of a word device corresponds to bit 0 of the device, and the LSB (least significant bit) corresponds to bit F.

E.g. When hexadecimal data **0001** is written to a Word device address

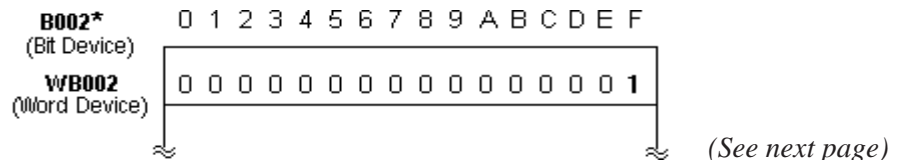

(from previous page)

- * 2 Define and use 16 bit length data.
- * 3 Define and use 32 bit length data.
- * 4 This device cannot write. Use it only for reading.



- **In this LS area, no 32-bit device is supported. Therefore, when the System Area is allocated to the BD, DL, or W33 devices, no LS Area other than the System Area can be used.**
- **When using the GP-570VM or GP-870VM, do not allocate the System Area for BD, DI, or W33 word addresses.**
- **Certain PLC models and versions may not be able to perform bit reading or writing.**

F30 not possible with versions 0.9 or lower
F50 not possible with versions 1.4 or lower
F50H not possible with versions 0.7 or lower
F80 not possible with any version
F81 not possible with any version
F120 not possible with any version
F200 not possible with any version

Check the information plate on the side of the PLC to find the PLC's version information.

When processing 16-bit single word data:

Internally, the GP basically processes 1 word as 16 bit length data. As a result, the reading and writing of 32 bit length data devices are processed as follows:

- Reading From 32 bit data, reads data only from the bottom 16 bits.
- Writing From 32 bit data, writes data only to the bottom 16 bits, as 0 is written to the top 16 bits.

E.g. When data is **12345678** hex.

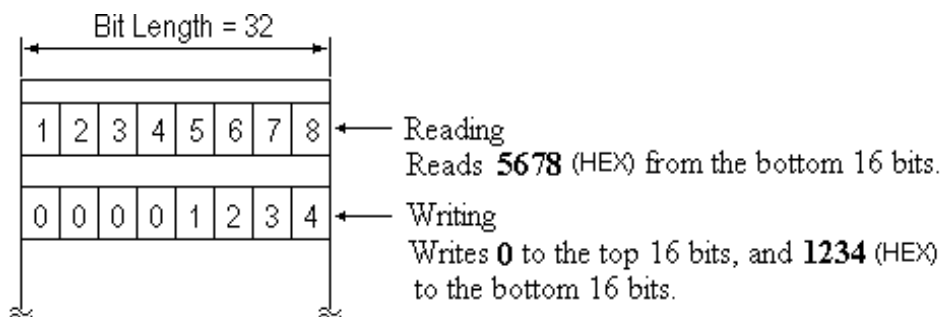

When processing 2 word 32-bit data:

Two word addresses at bit length 16 are necessary to handle 32 bit long data, but when using a 32 bit device, only one word address needs to be specified.

When using a 16 bit device

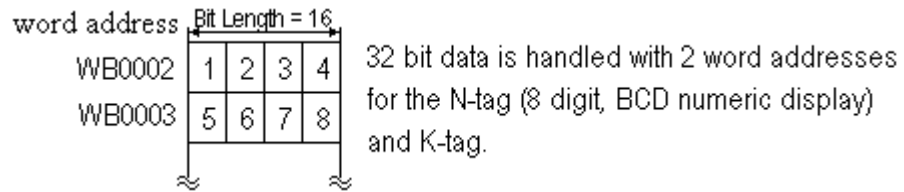

When using a 32 bit device

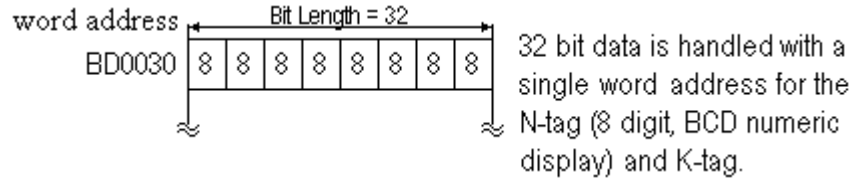

■ **FLEX-PC Series**

 Setup System Area here.

Device	Bit Address	Word Address	Particulars	
Input Relay	X0000 - X07FF	WX0000 - WX07F	L/H	
Output Relay	Y0000 - Y07FF	WY0000 - WY07F		
Internal Relay	M0000 - M03FF	WM000 - WM03F		
Extended Internal Relay	M0400 - M1FFF	WM040 - WM1FF		
Latch Relay	L0000 - L03FF	WL000 - WL03F		
Extended Latch Relay	L0400 - L1FFF	WL040 - WL1FF		
Special Relay	M8000 - M81 FF	WM800 - WM81F		
Timer	T0000 - T03FF	---		
Counter	C0000 - C01FF	---		
Timer (current value)	---	T0000 - T03FF		
Timer (setup value)	---	TS0000 - TS03FF		*1
Counter (current value)	---	C0000 - C01FF		
Counter (setup value)	---	CS0000 - CS01FF		*1
Data Register	---	D0000 - D2FFF		[Bit] 5]
Special Register	---	D8000 - D837F		[Bit] 5]
Link Register	---	W0000 - W3FFF		[Bit] 5]
File Register	---	R0000 - R7EFF	[Bit] 5]	

* 1 Define and use 16 bit length data.



- **Cannot read the *Timer* and *Counter* setup value. However, the write operation is possible only when the PLC is in program mode.**

- When the *Timer* and *Counter* setup values are written from the GP, the ladder is changed so that the setup value uses a relative reference. For this reason, be careful when the setup value for the *Timer* and *Counter* uses an indirect ladder. Normally, *access* is recommended for indirectly referenced devices.

2.3.4 Environment Setup

The following tables list Digital's recommended PLC and GP communication settings.

■ MICREX-F Series (using PC I/F module FFU120B)

GP Setup		FFU120B Setup	
Baud Rate	19200 bps	Baud Rate	19200 bps
Data Length	7 bits	Data Length	7 bits
Stop Bit	2 bits	Stop Bit	2 bits
Parity Bit	Even	Parity Bit	Even
Data Flow Control	ER Control	Transfer Condition	DTR on/ CTS on
Communication Format (RS-232C)	RS-232C	MODE Switch (RS-232C)	1
Communication Format (RS-422)	4-wire type	MODE Switch (RS-422)	3
---		Char. structure Switch	8 (INIT) is Off
---		RS-485 Station # setup Switch (Only for RS-485)	0
Unit No.	0 (fixed)	---	



Setup this data in *File Definition*. Communication is not possible when using a Link I/F switch.

■ MICREX-F Series (using General Interface Module NC1L-RS2)

GP Setup		NC1L-RS2 Setup	
Baud Rate	19200 bps	Baud Rate	19200 bps
Data Length	8 bits	Data Bit	8 bits
Stop Bit	1 bit	Stop Bit	1 bit
Parity Bit	None	Parity Bit	None
Data Flow Control	ER Control	Transfer Condition	DTR on/CTS on
Communication Format	RS-232C	MODE Setup	1
---		Character Structure Switch	8 (Initialize Setup Process) is Off (Initial file)
Unit No.	0 (fixed)	---	



Setup this data in *File Definition*. Communication is not possible when using a Link I/F switch.

■ MICREX-F Series (using PC I/F capsule FFK120A-C10)

GP Setup		FFK120A-C10 Setup	
Baud Rate	19200 bps	Baud Rate	19200 bps
Data Length	7 bits	Data Length	7 bits
Stop Bit	2 bits	Stop Bit	2 bits
Parity Bit	Even	Parity Bit	Even
Data Flow Control	ER Control	Transfer Condition	None
Communication Format (RS-232C)	RS-232C	MODE Switch (RS-232C)	1
Communication Format (RS-422)	4-wire type	MODE Switch (RS-422)	3
---		RS-485 Station # setup Switch (Only when using RS-485)	0
Unit No.	0 (fixed)	---	



Setup this data in *File Definition*. Communication is not possible when using a Link I/F switch.

■ MICREX-F Series (using PC I/F capsule FFK100A-C10)

GP Setup		FFK100A-C10 Setup	
Baud Rate	19200 bps	Baud Rate	19200 bps
Data Length	7 bits	Data Length	7 bits
Stop Bit	2 bits	Stop Bit	2 bits
Parity Bit	Even	Parity Bit	Even
Data Flow Control	ER Control	---	
Communication Format (When using RS-232C)	RS-232C	---	
Unit No.	0 (fixed)	---	
---		PK access	Permitted
---		Code conversion	Available



Setup this data in *File Definition*. Communication is not possible when using a Link I/F switch.

■ **MICREX-F Series (FLT-ASFK)**

GP Setup		Adapter Setup	
Baud Rate	19200 bps	Baud Rate	19200 bps
Data Length	8 bits	Data Length	8 bits
Stop Bit	1 bit	---	
Parity Bit	None	Parity Bit ON/OFF EVEN/ODD	OFF None
Data Flow Control	ER Control	---	
Communication Format	RS-232C	---	
Unit No.	0	---	
---		MODE	LOADER

■ **FLEX-PC Series (using Link I/F)**

GP Setup		Communication Unit / Interface Module Setup	
Baud Rate	19200 bps	Baud Rate	19200 bps
Data Length	7 bits	Data Length	7 bits
Stop Bit	1 bit	Stop Bit	1 bit
Parity Bit	Even	Parity Bit	Even
Data Flow Control	ER Control	Transfer Condition	DTR on/ CTS on
Communication Format (RS-232C)	RS-232C	MODE Switch (RS-232C)	1
Communication Format (RS-422)	4-wire type	MODE Switch (RS-422)	3
Unit No.	1	Station No.	1

■ **FLEX-PC Series (using CPU Direct Connection)**

GP Setup		PLC side Setup
Baud Rate	19200 bps (fixed)	---
Data Length	8 bits (fixed)	---
Stop Bit	1 bit (fixed)	---
Parity Bit	Odd (fixed)	---
Data Flow Control	ER Control (fixed)	---
Communication Format	4-wire type (fixed)	---
Unit No.	1 (fixed)	---





2.4 Yaskawa Electric

2.4.1 System Structure

The following describes the system structure for connecting the GP to Yaskawa PLCs.

Reference The Cable Diagrams mentioned in the following tables are listed in the section titled "2.4.2 Cable Diagrams".

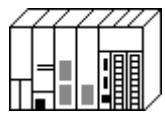
■ Memocon-SC Series (using Link I/F)

CPU	Link I/F	Cable Diagram	Cables	GP
		←————→		
	SIO Module			
U84, 84J	JAMSC-C8110	RS-232C (Cable Diagram 1)	Yaskawa Electric Corp's memory bus cable JZMSZ-W1015-21 ^{*1}	GP series
U84S	JAMSC-C8610			
GL40S	JAMSC-IF61 JAMSC-IF41A			
GL60H, GL70H	JAMSC-IF60 JAMSC-IF61			
GL60S	JAMSC-IF60 JAMSC-IF61			
	JAMSC-IF612	RS-422 (Cable Diagram 2)		

* 1 Due to the size of its connector case, this cable cannot be used for GP-270, GP-370, GP-377 and GP-377R series.



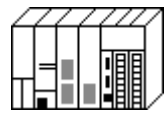
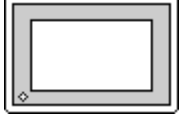

Note: Using Multiple Link I/Fs, maximum of 4 GP units can be connected at one time.

■ Memocon-SC Series (CPU Direct Connection)

CPU	Cable Diagram	Cables	GP
	←————→		
GL120	RS-232C (Cable Diagram 3)	Yaskawa Electric Corp's JZMSZ-120W0200-03	GP Series

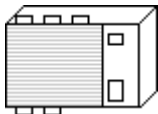
■ Control Pack Series (CPU Direct Connection)

CPU	Cable Diagram	Cables	GP
			
CP-9200 CP-9200H	RS-232C (Cable Diagram 1)	Yaskawa Electric Corp's Memo BUS Cable JZMSZ-W1015-21 ^{*2}	GP Series





* 1 Connect to CP9200/CP9200H's machine controller (4CN, 6CN).

* 2 Due to the size of its connector case, this cable cannot be used for GP-270, GP-370, GP-377, GP-377R series.

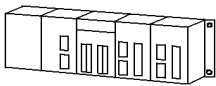

Two GPs can be connected to one CP-9200/CP9200H. When using two GPs, set it up so that the System Area of the GPs do not overlap.

■ Control Pack Series (Link I/F)

CPU	Link I/F	Cables	GP
			
CP-9200SH ^{*3}	JACP-317217(CN1)	(Cable Diagram 7) (RS-232C)	GP Series
	JACP-317217(CN2)	(Cable Diagram 8) (RS-232C)	
	JACP-317217(CN3)	(Cable Diagram 9) (RS-422)	

* 3 <1:1 Connection>

The drawing shown below is for the 1:1 connection. (CN means the circuit number.)

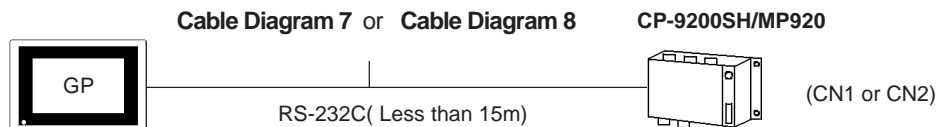

CN1, CN2, CN3 can be connected at the same time, however, only one GP can be connected to one CN since it cannot use the Multi Link connection.

When connecting a GP77R series' unit to a "***_21700_*****" or an older version of a 217IF unit, set the GP-PRO/PB III software "GP settings" Area's "Send Wait Time" to 20ms. ("GP Settings" - "Communication Settings" - "Advanced...")**

< 1:n Communication >

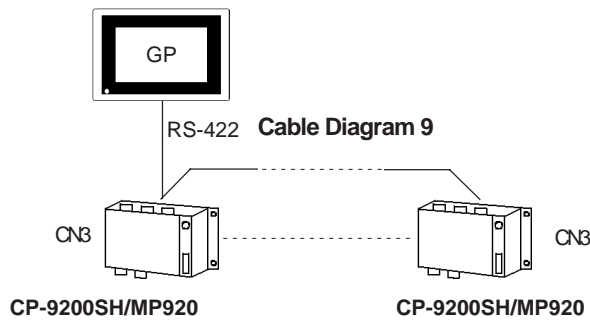

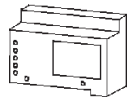
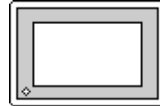

- Within this system a total of thirty two (32) CPU units can be connected to one GP. The GP is designed so that it can be connected with a maximum of thirty two (32) CPU units.
- Two GPs can be connected to one CP-9200/CP9200H. When using two GPs, set them up so that their System Areas do not overlap.

■ Memocon Micro (CPU Direct Connection)

CPU	Cable Diagram	GP
	←→	
Micro *1	RS-232C (Cable Diagram 5)	GP Series

* 1 Connect to **COM1** port.





■ PROGIC-8 Series (using CPU unit Link I/F)

CPU	Cable Diagram	Cables	GP
	←→	←→	
PROGIC-8 *1	RS-232C (Cable Diagram 4)	Yaskawa Electric 's JEPMC-W5310-03 *2	GP Series





* 1 Connect to the PLC unit's **PORT1(9P)** or **PORT2(15P)**.

* 2 Can only use with **PORT1** connection; **PORT2** cannot be used because it has a 15P connector.

■ Memocon-SC Series (GL 120/GL 130) (using Link I/F)

CPU	Link I/F	Cables	GP
	Computer Link Unit 		
GL120, GL130	FAMSC-120NOM 27100	RS-422 (Cable Diagram 6)	GP Series

■ MP900 Series (using Link I/F)

CPU	Link I/F	Cable Diagram	GP
	Computer Link Unit 		
MP930	MEMOBUS Port on CPU unit (Port1, Port2)	RS-232C (Cable Diagram 7)	GP Series
MP920	MEMOBUS Port on CPU unit (Port1, Port2)	RS-232C (Cable Diagram 7)	
	JEPMC-CM200 ^{*1} (CN1, CN2)		
	JEPMC-CM200 ^{*1} (CN3)	RS-422 (Cable Diagram 9)	

**1 Refer to the previous page's CP-9200SH data for connection details.*

Cable Diagram 2 (RS-422)

- When using Digital's RS-422 connector terminal adapter GP070-CN10-0

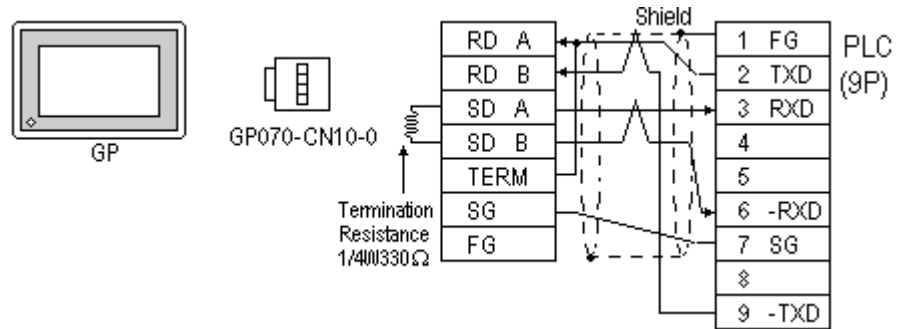

- When using Digital's RS-422 Cable, GP230-IS11-0

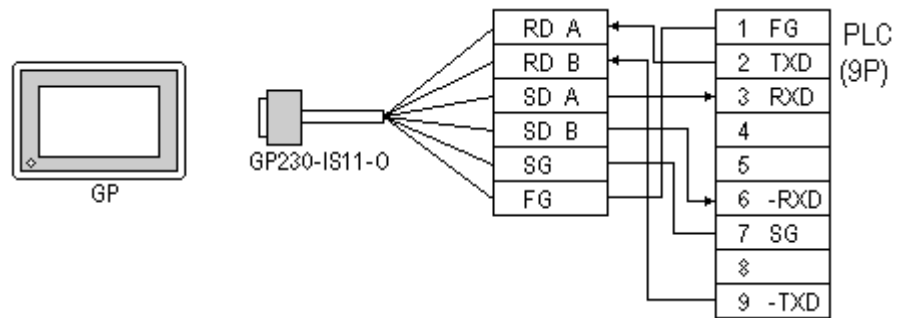

- When making your own cable connections

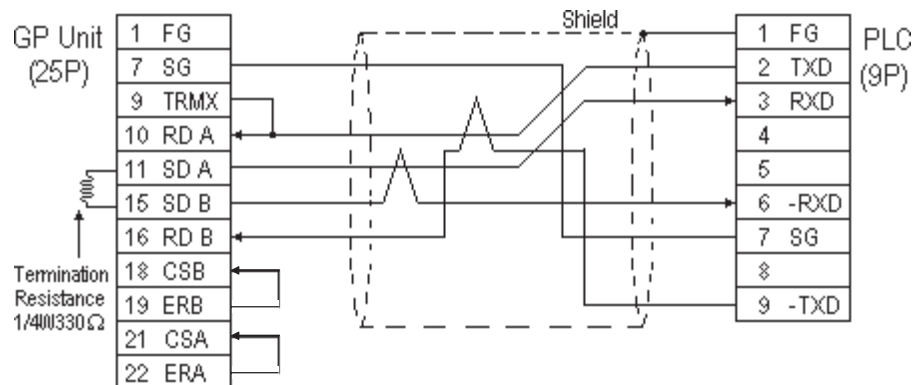

When connecting the #9 and #10 pins in the GP Serial I/F, a termination resistance of 100Ω is added between RDA and RDB.

Cable Diagram 3 (RS-232C)

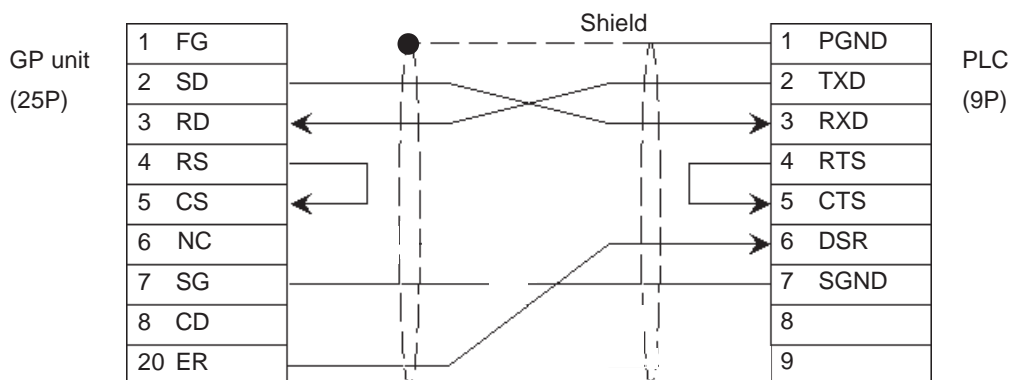

Cable Diagram 4 (RS-232C)

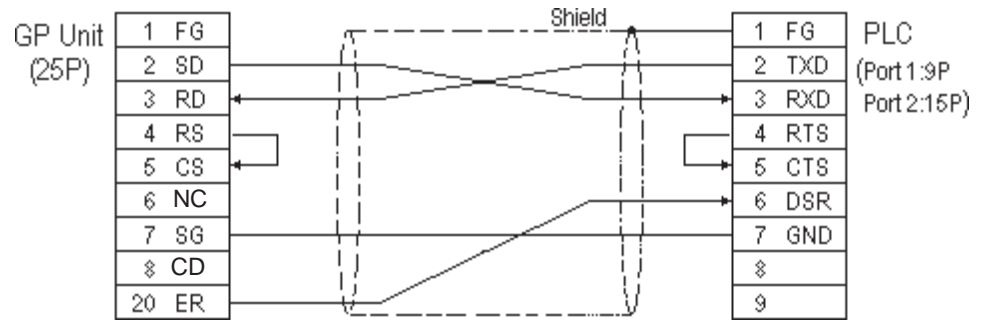

Cable Diagram 5 (RS-232C)

Note:

An RJ45 jack is used for the PLC.

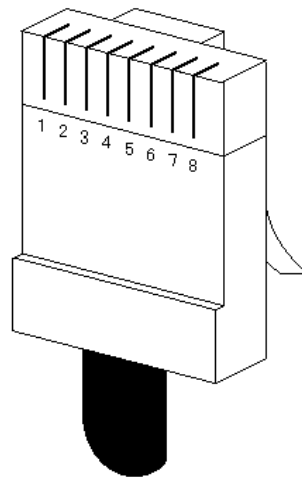

The pin numbers of the modular-jack for the connection diagrams below are based on the order described in the figure at the left.

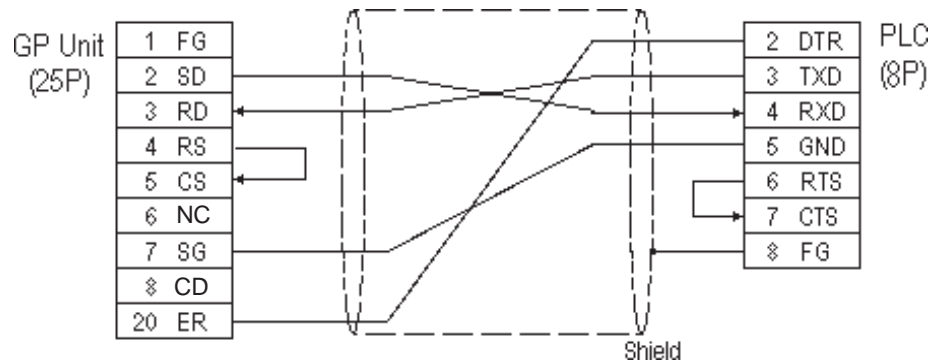

Cable Diagram 6 (RS-422)

- When using Digital's RS-422 connector terminal adapter GP070-CN10-0

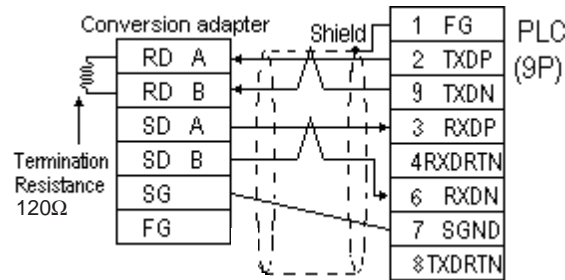

- When using Digital's RS-422 Cable, GP230-IS11-0

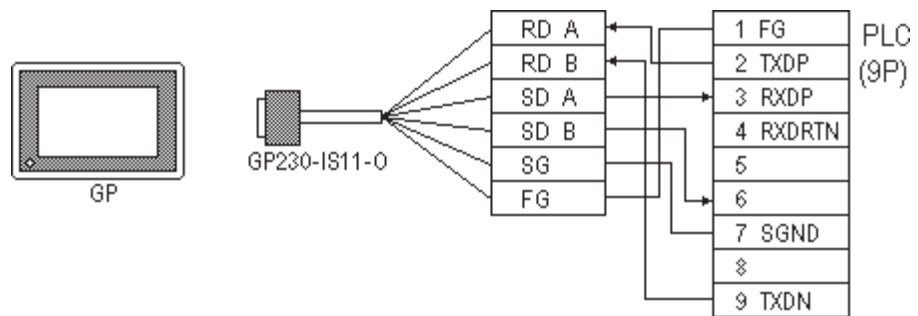

- When making your own cable connections

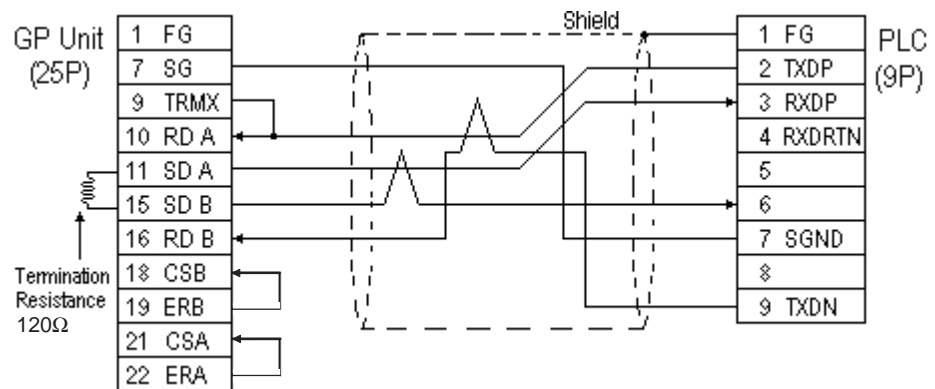

Note: When connecting the #9 and #10 pins in the GP Serial I/F, a termination resistance of 100Ω is added between RDA and RDB.

Cable Diagram 7 (RS-232C)

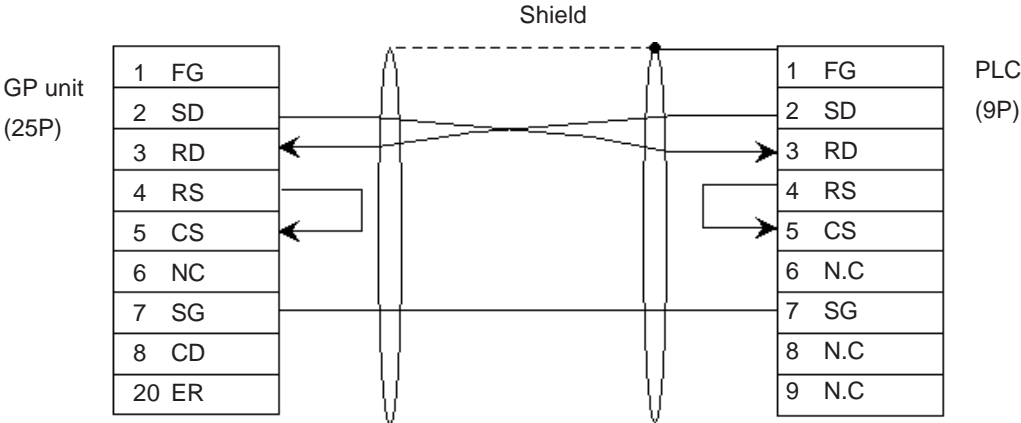

Cable Diagram 8 (RS-232C)

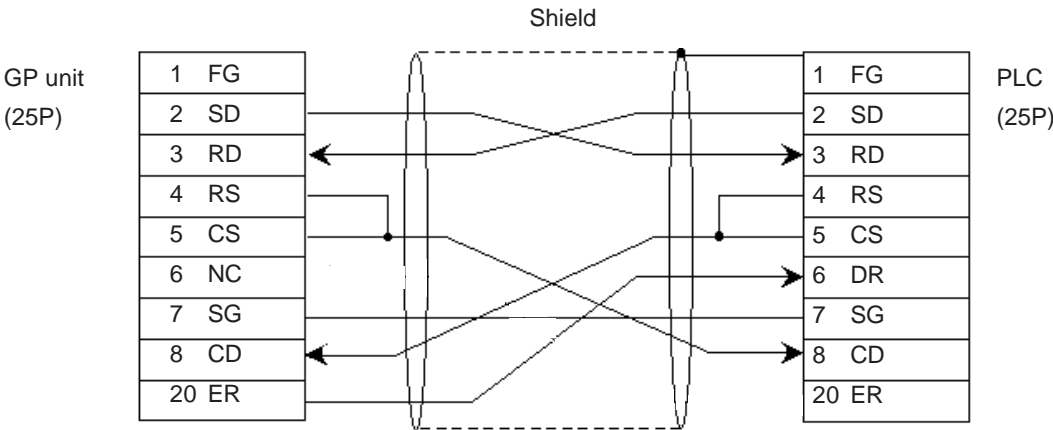

Cable Diagram 9 (RS-422)

- When using Digital's RS-422 Connector terminal adapter GP070-CN10-O.

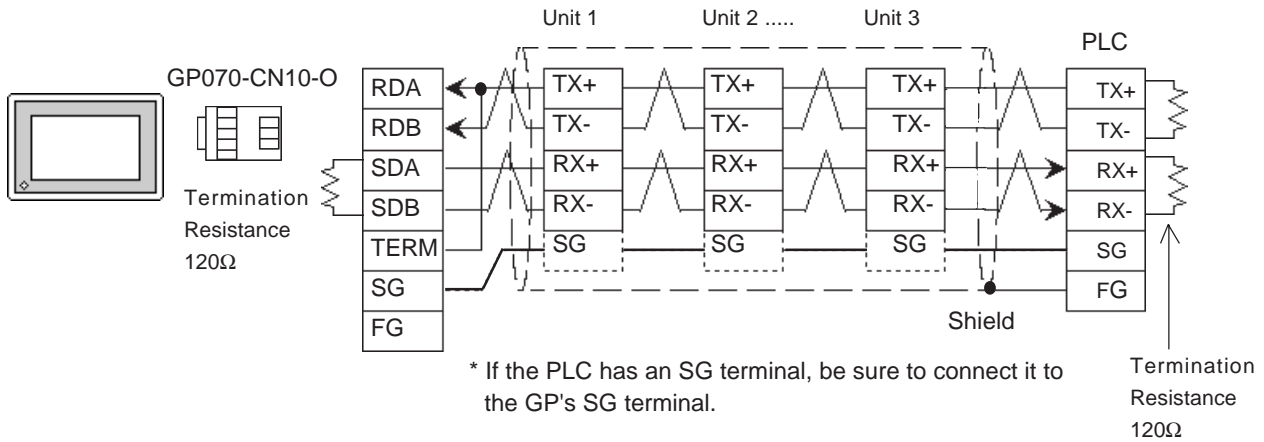

- When using Digital's RS-422 Cable, GP230-IS11-O.

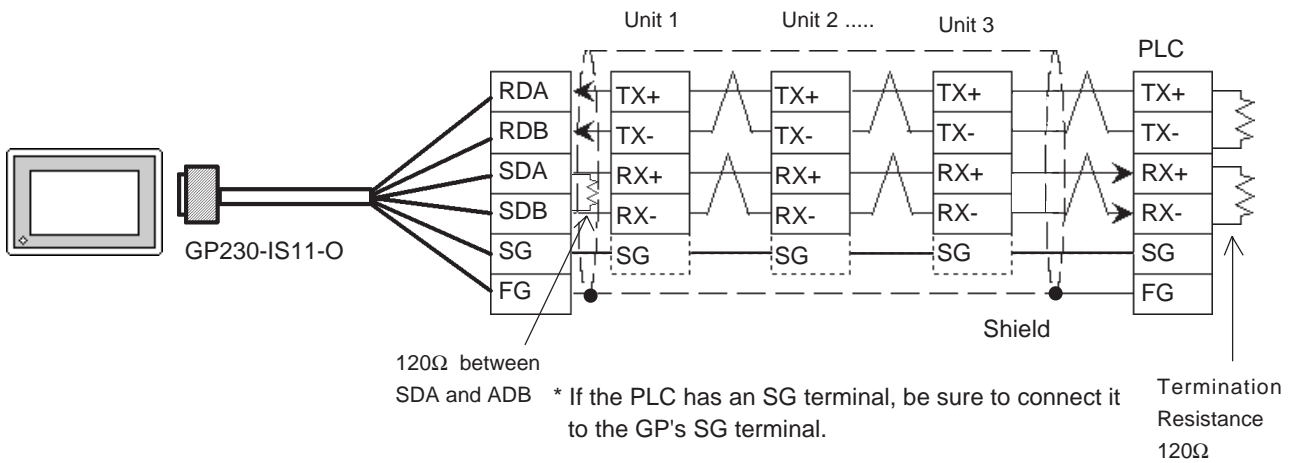

- When making your own cable connections

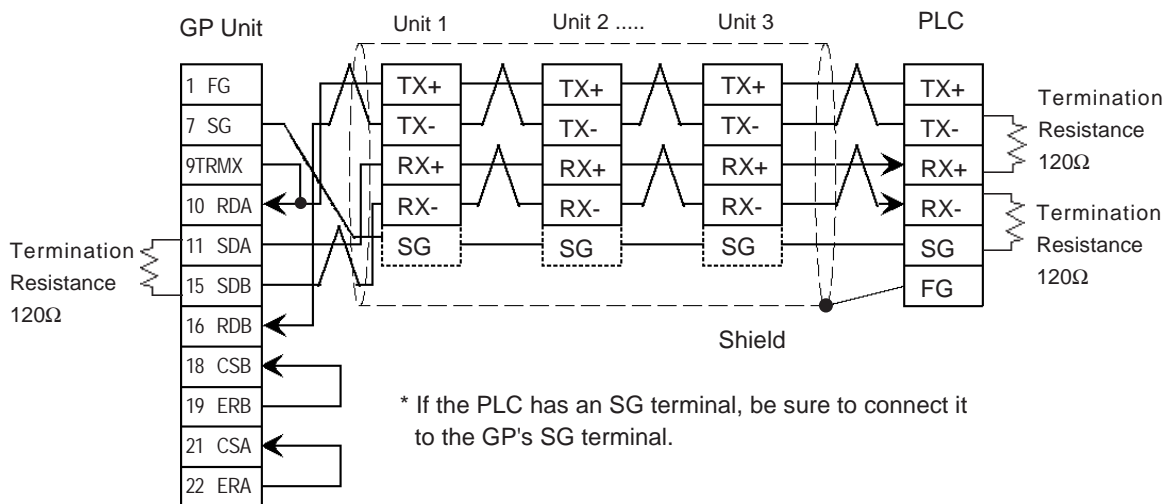

2.4.3 Supported Devices

The following describes the range of devices supported by the GP.

■ **Memocon-SC Series**

(U84/84J/U84S/GL40S/GL60H/GL70H/GL60S)

Setup System Area here.

Device	Bit Address	Word Address	Particulars	
Coil (Output/Internal)	00001 ~ 08192	---	'1	H/L
Input Relay	10001 ~ 14096	---	'1 '2	
Link Coil	D0001 ~ D1024	---	'1	
Input Register	---	30001 ~ 30512	Bit 5 '2	
Output/Keep Register	---	40001 ~ 49999	Bit 5	
Link Register	---	R0001 ~ R1024	Bit 5	
Constant Register	---	31001 ~ 35096	Bit 5	
Extended Register	---	A0000 ~ A7FFF	Bit 7	

■ Memocon-SC Series (GL120/GL130)

 Setup System Area here.

Device	Bit Address	Word Address	Particulars
Coil (Output/Internal)	000001 ~ 008192	---	*1
Input Relay	100001 ~ 101024	---	*1 *2
Link Coil 1	D10001 ~ D11024	---	*1
Link Coil 2	D20001 ~ D21024	---	*1
MC Relay 1	X10001 ~ X10256	---	*1 *2
MC Relay 2	X20001 ~ X20256	---	*1 *2
MC Coil 1	Y10001 ~ Y10256	---	*1
MC Coil 2	Y20001 ~ Y20256	---	*1
MC Code Relay 1	M10001 ~ M10096	---	*1 *2
MC Code Relay 2	M20001 ~ M20096	---	*1 *2
MC Control Relay 1	P10001 ~ P10256	---	*1 *2
MC Control Relay 2	P20001 ~ P20256	---	*1 *2
MC Control Coil 1	Q10001 ~ Q10256	---	*1
MC Control Coil 2	Q20001 ~ Q20256	---	*2
Input Register	---	300001 ~ 300512	Bit 1 5 *2
Output Register	---	300001 ~ 300512	Bit 1 5
Keep Register	---	400001 ~ 409999	Bit 1 5
Link Register 1	---	R10001 ~ R11024	Bit 1 5
Link Register 2	---	R20001 ~ R21024	Bit 1 5
Constant Register	---	700001 ~ 704096	Bit 1 5

H/L

*1 Can also specify as a word (16 bit data)

*2 Cannot perform data write.

■ Control Pack Series

 Setup System Area here.

Device	Bit Address	CP-9200/CP-9200H's Register No. Corresponding to Address	Particulars
Input Register	00001 ~ 02048	IB00000 ~ IB007FF	"1" rowspan="3">L/H
Output Register	02049 ~ 04096	OB00000 ~ OB007FF	
System Register	10001 ~ 12048	SB000000 ~ SB00127F (CPU#0's S-Register)	

Device	Word Address	CP-9200/CP-9200H's Register No. Corresponding to Address	Particulars
Input Register	49744 ~ 49871	IB00000 ~ IB007FF	"1" L/H
Output Register	49872 ~ 49999	OB00000 ~ OB007FF	
System Register	30001 ~ 30256	SW00000 ~ SW00255 (CPU#0's S-Register)	
Data Register	31001 ~ 33048 (CP-9200H only)	DW00000 ~ DW02047 (CPU#1's D-Register)	
	40001 ~ 42048	DW00000 ~ DW02047 (CPU#0's D-Register)	
Common Register	42049 ~ 49743	MW00000 ~ MW07694	

* 1 Can also specify as a word (16 bit data).



- If the above devices are used in the Control Pack series, the addresses converted using the above table should be entered.
- When you wish to use CP-9200 with CPU#1's Data Register or System Register, be sure to copy it to the Common Register (MW00000 ~ MW07694) first.

■ Memocon Micro

 Setup System Area here.

Device	Bit Address	Word Address	Particulars
Coil (Output/Internal)	00001 ~ 01531	---	"1" H/L
Input Relay	10001 ~ 10511	---	
Input Register	---	30001 ~ 30047	
Output/Keep Register	---	40001 ~ 41871	

* 1 Can also specify as a word (16 bit data).

■ PROLOGIC-8 Series

 Setup System Area here.

Device	Bit Address	Word Address	Particulars
Output Coil	O1 ~ O512	---	*1
Input Relay	I1 ~ I512	---	*1 *2
Internal Coil	N1 ~ N1536	---	*1
Link Coil	D1 ~ D1024	---	*1
Data Register	---	W1 ~ W2048	Bit 15
Data Register (1-word data)	---	SW1 ~ SW2048	Bit 15 *3 H/L
Data Register (2-word data)	---	DW1 ~ DW2048	Bit 15 *3
Input Register	---	Z1 ~ Z128	*2
Link Register	---	R1 ~ R1024	
Link (1-word data)	---	SR1 ~ SR2048	*3
Link (2-word data)	---	DR1 ~ DR2048	*3

* 1 Can also specify as a word (16 bit data)

* 2 Cannot perform data write.

* 3 A data format compatible register. This is a virtual register applicable for the data in the PLC. It uses data register (W) and link register (R). The range of data which can be handled as 1-word is -9999 to 9999.

1) Cautions related to using data register (SW) and link register (SR) are applicable to 1-word data.

If the SW and the SR are used, be sure to use values in the range from -9999 to 9999. Data must be displayed in four digits (decimal notation).

Differences in displayed values between SW, SR and W, R

Data in the PLC	SW, SR	W, R
9999	9999	9999
1001	1001	1001
1000	1000	1000
999	999	999
0	0	0
-1	-1	32769
-999	-999	33767
-1000	-1000	33768
-1001	-1001	33769
-9999	-9999	42767

(Continued on next page)

2) *Cautions related to using a register applicable for 2-word data.
Using data register (DW) and link register (DR)*

If the DW and the DR are used, be sure to use values in the range from -9999 to 9999. Data must be displayed in four digits (decimal notation).

Differences in displayed values between DW, DR and W, R (2-word)

Data in the PLC	DW, DR	W, R
99999999	99999999	655304463
10000001	10000001	65536001
10000000	10000000	65536000
9999999	9999999	65535999
10000	10000	65536
9999	9999	9999
0	0	0
-1	-1	2147483649
-9999	-9999	2147493647
-10000	-10000	2147549184
-10001	-10001	2147549185
-9999999	-9999999	2212955111

■ CP-9200SH / MP900 Series

Setup System Area here.

Device	GP Device Address	CP-9200SH Device	Amount	Particulars
Coil (bit device)	GMB00000 ~ GMB0624E	MB00000 + OFFSET to MB0624E + OFFSET	9999	
Coil (word device)	GMB0000 ~ GMB0624	MB0000 + OFFSET to MB0624 + OFFSET	625	*2
Input Relay (bit device)	GIB00000 ~ GIB0270E	IB00000 + OFFSET to IB0270E + OFFSET	9999	*1
Input Relay (word device)	GIB0000 ~ GIB0270	IB0000 + OFFSET to IB0270 + OFFSET	625	*1 *2
Hold Register (word device)	GMW0000 ~ GMW1023	MW0000 + OFFSET to MW1023 + OFFSET	1024	Bit F
	GMW1024 ~ GMW2047	MW1024 + OFFSET to MW2047 + OFFSET	1024	Bit F
	GMW2048 ~ GMW3071	MW2048 + OFFSET to MW3071 + OFFSET	1024	Bit F
	GMW3072 ~ GMW4095	MW3072 + OFFSET to MW4095 + OFFSET	1024	Bit F
	GMW4096 ~ GMW5119	MW4096 + OFFSET to MW5119 + OFFSET	1024	Bit F
	GMW5120 ~ GMW6143	MW5120 + OFFSET to MW6143 + OFFSET	1024	Bit F
	GMW6144 ~ GMW7167	MW6144 + OFFSET to MW7167 + OFFSET	1024	Bit F
	GMW7168 ~ GMW8191	MW7168 + OFFSET to MW8191 + OFFSET	1024	Bit F
	GMW8192 ~ GMW9215	MW8192 + OFFSET to MW9215 + OFFSET	1024	Bit F
	GMW9216 ~ GMW9998	MW9216 + OFFSET to W9998 + OFFSET	783	Bit F
Input Register (word device)	GIW0000 ~ - GIW03FF	IW0000 + OFFSET to IW03FF + OFFSET	1024	Bit F *1
	GIW0400 ~ GIW07FF	IW0400 + OFFSET to IW07FF + OFFSET	1024	Bit F *1
	GIW0800 ~ GIW08FF	IW0800 + OFFSET to IW08FF + OFFSET	1024	Bit F *1
	GIW0C00 ~ GIW0FFF	IW0C00 + OFFSET to IW0FFF + OFFSET	1024	Bit F *1
	GIW1000 ~ GIW13FF	IW1000 + OFFSET to IW13FF + OFFSET	1024 *Device range "0000" indicates it is hexa-decimal	Bit F *1

L/H

*1 Can be read out from a GP, however cannot be written to a GP.

*2 Cannot be written in the last (16th) bit of this address.(i.e, GMB0624/GIB0270)



- Designate the LS area bit at the end of the Word Address, using from 0 to F.
- Since the CP-9200SH unit's protocol is applicable to a 1:n connection, it will differ from the MEMOCON-SC's protocol and internal method of representing devices. When you wish to modify the screen data from a MEMOCON-SC, you will need to reenter device data.
- All system area settings must be entered within each block. Any settings that extend into other blocks are not allowed.

(Example: You cannot enter a 20 word long setting, starting from GMW1010.)



When you are setting up parts and tags in GP-PRO/PB III, you can designate PLC's station numbers as you are inputting addresses. If you do not designate the station numbers, the number following the one you previously entered will be automatically selected. (The factory setting is "1".)

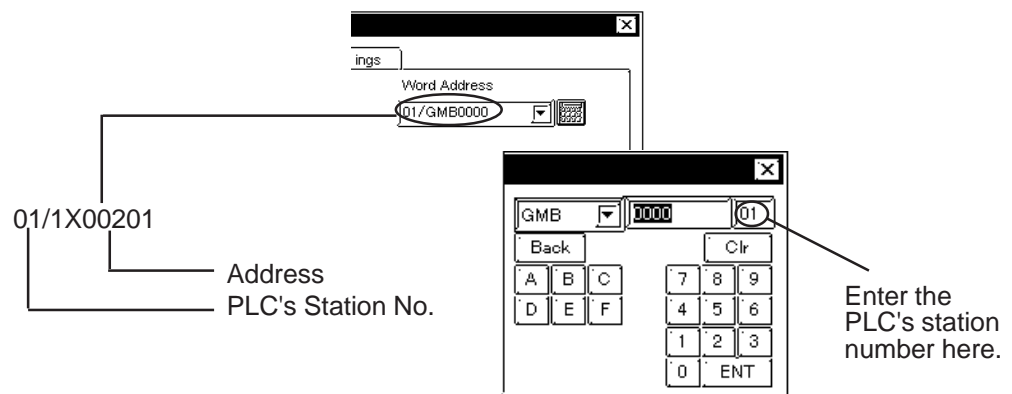

2.4.4 Environment Setup

The following lists Digital's recommended PLC and GP communication settings.

■ Memocon-SC Series (GL40S/GL60S/GL60H/GL70H) (GL120CPU Direct Connection)

GP Setup		Communication Module Setup	
Baud Rate	19200 bps	Baud Rate	19200 bps
Data Length	8 bits (fixed)	Transfer Mode	RTU Mode (fixed)
Stop Bit	1 bit	Stop Bit	1 bit
Parity Bit	Even	Parity On/Off EVEN/ODD	ON EVEN
Data Flow Control	ER Control	---	
Communication Format	RS-232C	---	
---		Delay Count *1	0
Unit No.	1	Station Number Setting	1

■ Memocon-SC Series (U84/U84J/U84S)

GP Setup		Communication Module Setup	
Baud Rate	19200 bps	Baud Rate	19200 bps
Data Length	8 bits	Transfer Mode	RTU Mode
Stop Bit	1 bit	Stop Bit	1 bit
Parity Bit	Even	Parity Bit	EVEN
Data Flow Control	ER Control	---	
Communication Format	RS-232C	---	
---		Port Delay Timer	0
Unit No.	1	Address	1

■ Memocon-SC Series (GL120/GL130)

GP Setup		Communication Module Setup	
Baud Rate	19200 bps	Baud Rate	19200 bps
Data Length	8 bits		
Stop Bit	1 bit	Stop Bit	1 bit
Parity Bit	Even	ON/OFF	ON
Data Flow Control	ER Control	Even/ODD	Even
Communication Format	RS-422	Communicationsport	RS-422
---		Slave address No.	1
Unit No.	1	Communications bit	RTU mode (fixed)

* 1 There is no Delay Count for the JAMSC-IF60 SIO Module.

■ **PROGIC-8**

GP Setup		Port 1/Port 2 Setup	
Baud Rate (for Port 1 connection)	9600 bps (fixed)	---	
Baud Rate (for Port 2 connection)	19200 bps	Baud Rate (for Port 2 connection)	19200 bps
Data Length	8 bits	---	
Stop Bit	1 bit	---	
Parity Bit	Even	---	
Data Flow Control	ER Control	---	
Communication Format	RS-232C	---	
Unit No.	1	---	

■ **Control Pack Series**

GP Setup		Machine Controller 4CN/6CN Setup	
Baud Rate	9600 bps	Baud Rate	9600 bps
Data Length	8 bits	Data Bit	8 bits
Stop Bit	1 bit	Stop Bit	1 bit
Parity Bit	Even	Parity Bit	Even
Data Flow Control	ER Control	---	
Communication Format	RS-232C	---	
Unit No.	1	Station Number Setting	1

■ **Memocon Micro**

GP Setup		Comm1 Port Setup	
Baud Rate	9600 bps	Baud Rate	9600 bps
Data Length	8 bits	Data Bit	8 bits
Stop Bit	1 bit	Stop Bit	1 bit
Parity Bit	Even	Parity Bit	Even
Data Flow Control	ER Control	---	
Communication Format	RS-232C	---	
Unit No.	1	Station Number Setting	1

■ Control Pack Series for CP-9200SH

	GP Setup	PLC Setup
Baud rate	9600bps	9600bps
Data Length	8	8
Stop Bit	1	1
Parity Bit	Even	Even
Data Flow Control	ER Control	ER Control
Communication Format (RS-232C)	RS-232C	CN1 or CN2
(RS-422)	4 Wire-Type	CN3
System Area Start Address	GMW0000	-----
Station No.	1 ~ 32	1 ~ 32



- When connecting the GP77R Series unit to the "*****-21700-*****" or older version of 217IF unit, select the "GP Settings" menu's "Communication Settings" tab in 3.0 or later version of GP-PRO/PB III for Windows screen creation software, and click on the "Advanced" field, and then designate "20ms" for the "Send Wait" setting.
- A ladder program is needed when connecting the GP to a Yaskawa CP-217IF link I/F unit.
- Be aware that this sample program enables the GP to communicate with only one CN unit, and when you wish to use more than one CN unit at the same time you will need to create a ladder program for each CN.
- The PLC's communication settings cannot be entered by this program. You will need to enter these settings via the ladder software.

■ MP900 Series

GP Setup		PLC Setup	
Baud rate	19200bps	Baud rate	19.2Kbps
Data Length	8	Data Length	8
Stop Bit	1	Stop Bit	1
Parity Bit	Even	Parity Bit	Even
Data Flow Control	ER Control	Send Mode	RTU
Communication Format (RS-232C)	RS-232C	Serial I/F (RS-232C)	RS-232C
Communication Format (RS-422)	4 Wire-Type	Serial I/F (RS-422)	RS-485
Unit No.	1	Device Address	01
_____		Master Slave	Slave
_____		Transmission Protocol	MEMOBUS



- A ladder program is needed when connecting the GP Series unit to a Yaskawa Electric corporation CP-217IF link I/F unit's CN1,CN2,CN3 or to a MP930 CPU's MEMOBUS Port (Port 1, Port 2).
- Be aware that this sample program enables the GP to communicate with only one CN unit, and when you wish to use more than one CN unit at the same time you will need to create a ladder program for each CN.
- The PLC's communication settings cannot be entered by this program. You will need to enter these settings via the ladder software.

■ MP900 Series Sample program

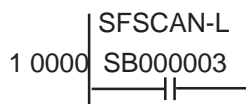

1 0001 IFON

2 0002 |-----| 00000

2 0004 |-----| 00000

2 0006 |-----| 00000

2 0008 |-----| 00000

2 0010 |-----| 00000

2 0012 |-----| 32787

2 0014 |-----| 00000

2 0016

2 0017

1 0018 IEND

Excuted once only,
when the unit's power
is turned on. (Initialize
the message receive
function parameters.)

- ⇒ DW00008 Coil Offset Setting
- ⇒ DW00009 Input Relay Offset Setting
- ⇒ DW00010 Input Register Offset Setting
- ⇒ DW00011 Hold Register Offset Setting
- ⇒ DW00012 Write Range LO
- ⇒ DW00013 Write Range HI
- ⇒ DW00014 System Register Clear
- ⇒ DW00024 Normal Path Counter Clear
.../036@
- ⇒ DW00025 Error Counter Clear
.../039@

1 0019

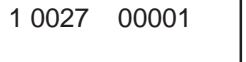
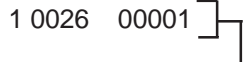
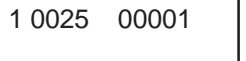
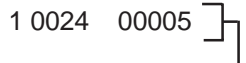
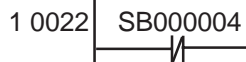

1 0028

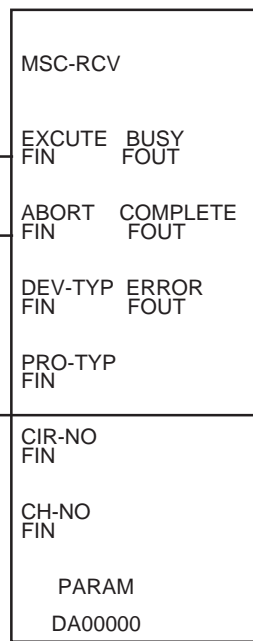

Message Reception Function
(Standard System Function)

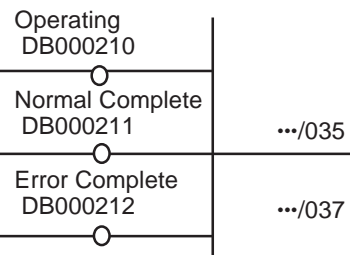

Enter 8 to Port 1 and Port 2 with the MP930CPU.
Enter 5 when using CN1, CN2 or CN3 with the CP-217IF.

Enter the GP or CN's Port No.

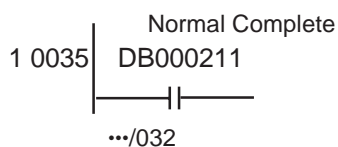

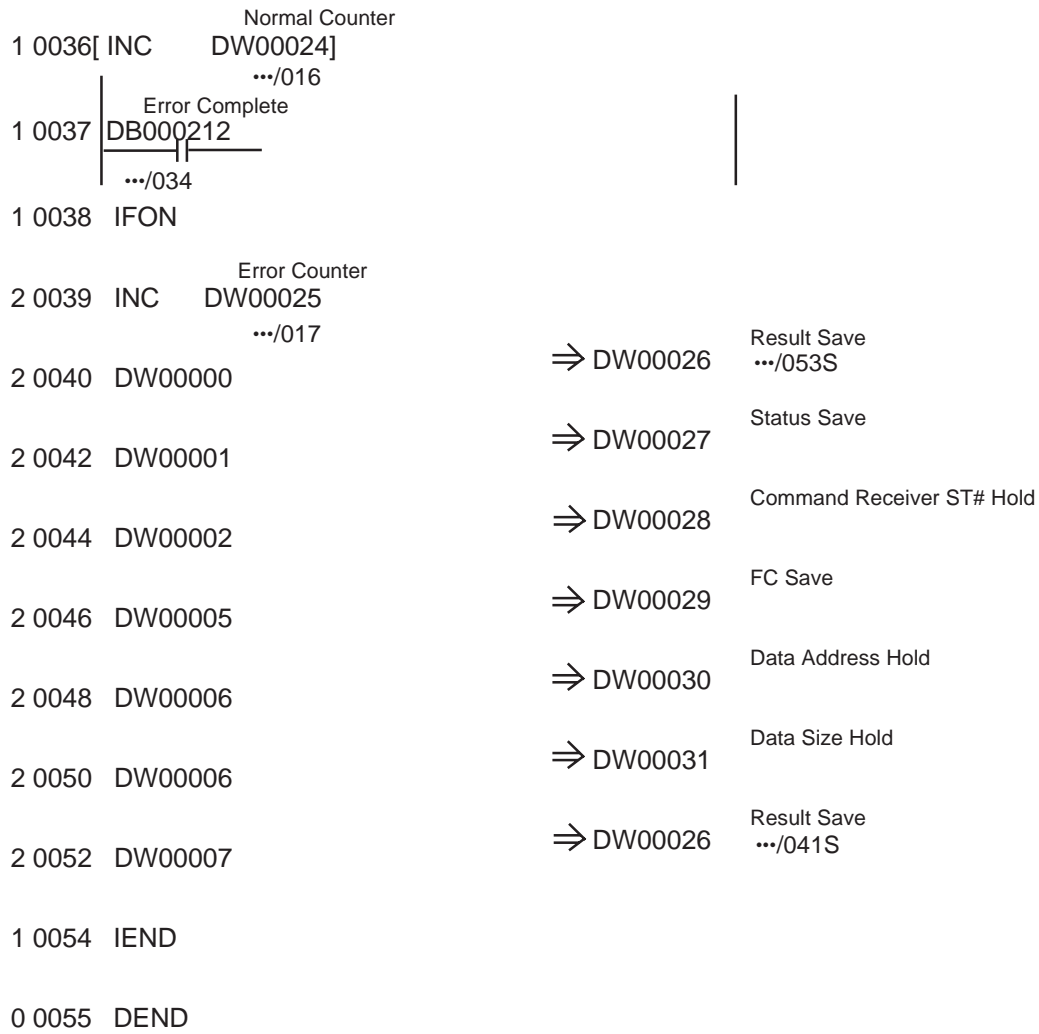



2.5 Hitachi

2.5.1 System Structure

The following describes the system structure for connecting the GP to Hitachi Ltd. PLCs.

Reference The Cable Diagrams mentioned in the following tables are listed in the section titled "2.5.2 Cable Diagrams".

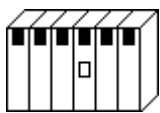
■ HIDIC-S10α Series (using Link I/F)

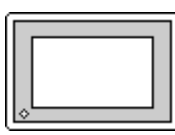
CPU	Link I/F	Cable Diagram	GP
	 Upper Link Module		
2α (LWP000) ^{*1} 2α E(LWP040) ^{*1} 2α H(LWP070) ^{*1}	CPU unit Link I/F	RS-422 (Hitachi H-7338 type; Cable Diagram 1)	GP Series
4α, 4αF	LWE805		



* 1 Connect to the CPU Module's HOST LINK COMPUTER LINK Input/Output Terminal (Upper Calculation I/F).

■ S10 mini Series (using Link I/F)

CPU	Link I/F	Cable Diagram	GP
LQP000 LQP010 LQP011	LOE060	RS-232C <Cable Diagram 6>	GP Series

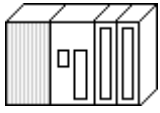
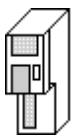

■ HIDIC H Series (using Link I/F)

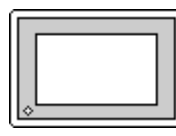
Procedure 1 for transmission control

CPU	Link I/F	Cable Diagram	Cable	GP
	 COMM Module			
H-300(CPU-03Ha), H-700(CPU-07Ha), H-2000(CPU-20Ha), H-2002 (CPU2-20H)	COMM-H COMM-2H	RS-232C (Cable Diagram 2)	RS-232C Hitachi peripheral cable GPCB05H ^{*1}	GP Series
H-302(CPU2-03H) H-702(CPU2-07H) H-4010 (CPU3-40H)	COMM-2H	RS-422 (Cable Diagram 4)		

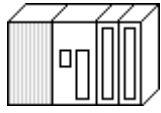
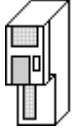

* 1 Due to the size of its connector case, this cable cannot be used for GP-270, GP-370, GP-377, and GP-377R series.

■ HIDIC H Series/COMM-2H (using Link I/F)
 Procedure 2 for transmission control

CPU	Link I/F	Cable Diagram	Cable	GP
	 COMM Module			
H-302 (CPU2-03H) H-702 (CPU2-07H) H-2002 (CPU2-20H) H-4010 (CPU3-40H)	COMM-2H	RS-232C (Cable Diagram 2) RS-422 (Cable Diagram 4)	RS-232C Hitachi's peripheral cable GPCB05H ^{*1}	GP Series

**1 Due to the size of its connector case, this cable cannot be used for GP-270, GP-370, GP-377, and GP-377R series.*

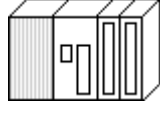
■ HIDIC H Series (CPU Direct Connection)

CPU	Cable Diagram	Cable	GP
			
H20,H28,H40,H64 H-200(CPU-02H) ^{*1} H-300(CPU-03Ha) ^{*1} H-700(CPU-07Ha) ^{*1} H-2000(CPU-20Ha) ^{*1}	RS-232C (Cable Diagram 2)	Hitachi peripheral cable GPCB05H ^{*9}	GP Series
H-252C(CPU22-02HC) ^{*1*2} H-302(CPU2-03H) H-702(CPU2-07H) H-2002(CPU2-20H) ^{*1} H-4010(CPU3-40H) ^{*1*4}	(Cable Diagram 2,3) ^{*3}		
EH-150(EH-CPU104, EH-CPU208, EH-CPU316) ^{*5*7}	RS-232C (Cable Diagram 2,3) ^{*8}		
EH-150(EH-CPU448) ^{*6*7}	RS-422 (Cable Diagram7)		

** 1 Connect to the CPU module's peripheral port.*

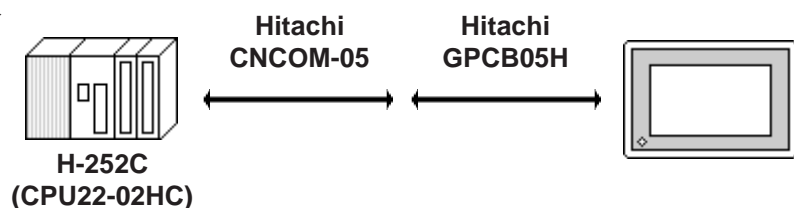

** 2 If the CPU is connected to port 2, a Hitachi CNCOM-05 conversion cable between the round connector (8-pin) and the D sub-connector (15-pin) is required.*

<Fig. 1>

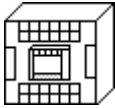

- *3 You will need to change the wiring depending on the baud rate. Use (Cable Diagram 2) when the baud rate is 4800bps, and use (Cable Diagram 3) when the baud rate is 19200bps. <Fig.1> is only for when the baud rate is 4800bps.
- *4 If the CPU's software revision is J or later, and DIPSWI's No.3 and No.4 are turned OFF, you can set the baud rate to 38400bps by using (Cable Diagram3).
- *5 Connect to the CPU module's serial port 1 or serial port 2.
- *6 Connect to the CPU module's serial port 1.
- *7 If the CPU is connected to a GP, a Hitachi EH-RS05 conversion cable between the modular jack (8-pin) and the D sub-connector (5-pin) is required.
- *8 If the CPU is connected to serial port 2, you will need to change the wiring depending on the baud rate.
 When the baud rate is 19200bps or 38400bps, use Cable Diagram 3.
 When the baud rate is 4800bps or 9600bps, use Cable Diagram2.
- *9 Due to the size of its connector case, this cable cannot be used for GP-270, GP-370, GP-377, and GP-377R series.

■ HIZAC EC Series (CPU Direct Connection)

CPU	Cable Diagram	GP
		
EC-40HR	RS-232C (Cable Diagram 5)	GP Series

2.5.2 Cable Diagrams

The cable diagrams illustrated below and the cable diagrams recommended by Hitachi Ltd. may differ; however, using these cables for your PLC operations will not cause any problems.



Ground your PLC's FG terminal according to your country's applicable standard. For details, refer to the corresponding PLC manual.



- **Connect the FG line of the Shield cable to either the GP or PLC, depending on your environment. When using a connector hood and grounding the FG line, be sure to use an electrical conductor. The following connection diagrams show examples for connecting a shielded cable to the PLC.**
- **For the RS-232C connection, use a cable length less than 15m.**
- **If a communications cable is used, it must be connected to the SG (signal ground).**
- **For the RS-422 connection, refer to Hitachi's PLC manual for the cable length.**

Cable Diagram 1 (RS-422)

- When using Digital's RS-422 connector terminal adapter GP070-CN10-0

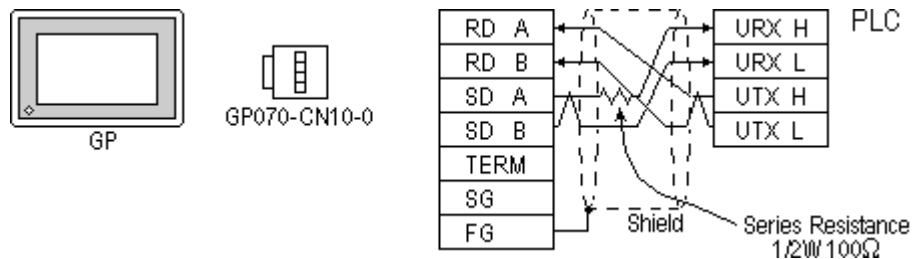

- When using Digital's RS-422 Cable, GP230-IS11-0

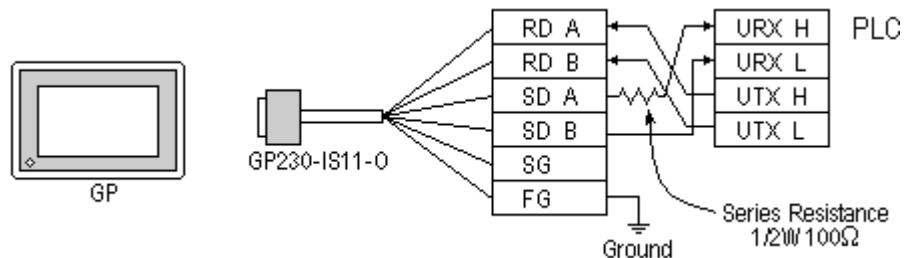

- When making your own cable connections

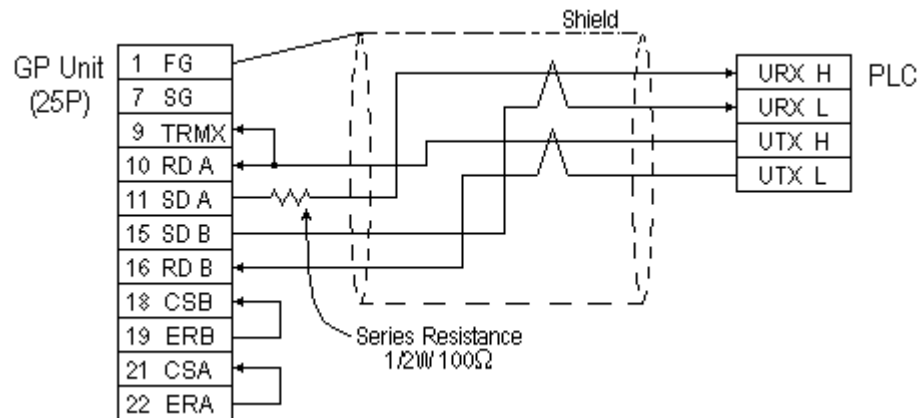

- When making your own connections, we recommend using Hitachi Densen's KPEV-SB-3P0.5mm² cable.
- When connecting the #9 and #10 pins in the GP Serial I/F, a termination resistance of 100Ω is added between RDA and RDB.

Cable Diagram 2 (RS-232C)

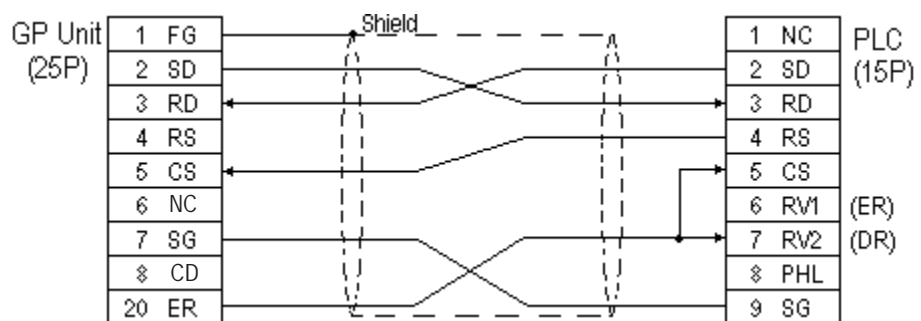

When an error develops during communication, there may be a delay before the error message displays as the unit runs the retry process.



In Procedure 1 for transmission control, when the GP and PLC program console (GPCL) are operated at the same time, a PLC COM ERROR: (02:37) on the GP and a CPU Hold Error in the GPCL may develop. In such cases, the GP automatically reverts to its normal state. Run the GPCL operation again.

Cable Diagram 3 (RS-232C)

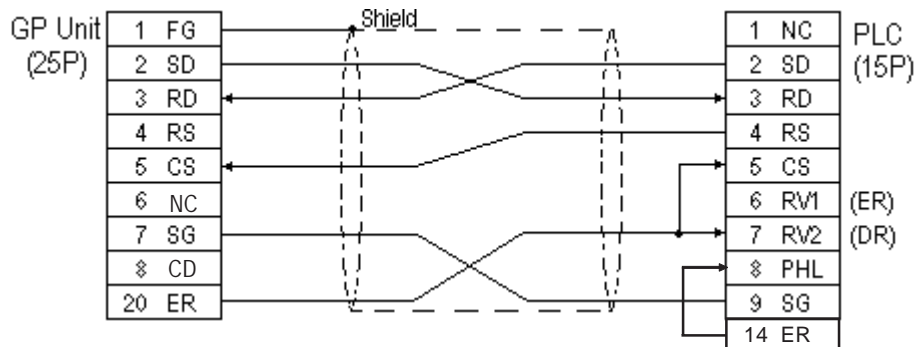

Note: When an error develops during communication, there may be a delay before the error message displays as the unit runs the retry process.



In Procedure 1 for transmission control, when the GP and PLC program console (GPCL) are operated at the same time, a PLC COM ERROR: (02:37) on the GP and a CPU Hold Error in the GPCL may develop. In such cases, the GP automatically reverts to its normal state. Run the GPCL operation again.

Cable Diagram 4 (RS-422)

- When using Digital's RS-422 connector terminal GP070-CN10-0 adapter

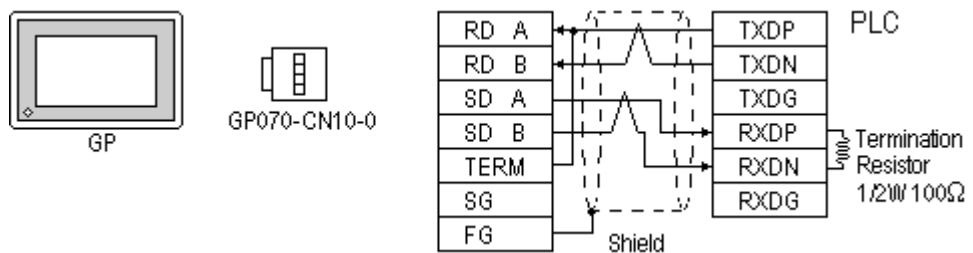

- When using Digital's RS-422 Cable, GP230-IS11-0

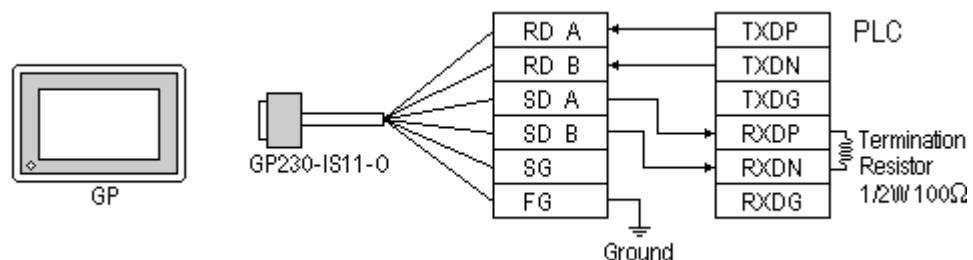

- When making your own cable connections

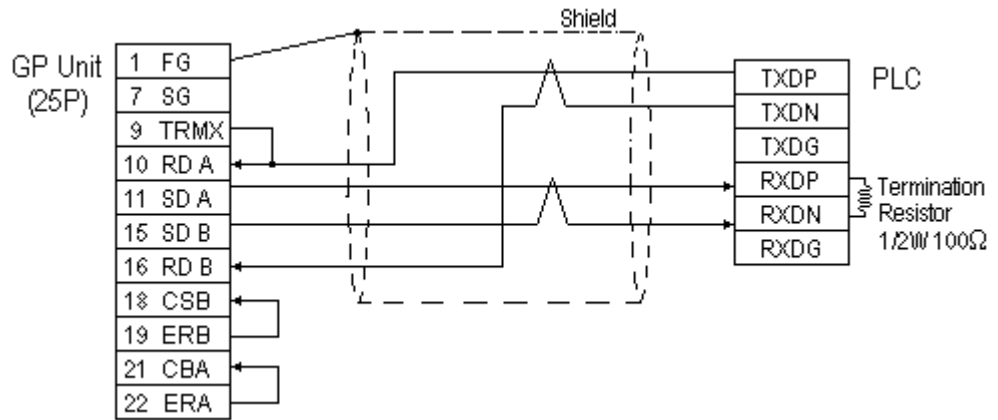

When an error develops during communication, there may be a delay before the error message displays, as the unit runs the *retry* process.



When the GP and PLC program consoles (GPCL) are operated at the same time, a PLC COM ERROR: (02:37) on the GP and a CPU Hold Error in the GPCL may develop. In such cases, the GP automatically reverts to its normal state. Run the GPCL operation again.



- When making your own connections, we recommend using Hitachi Densen's KPEV-SB-3P0.5mm² cable.
- When connecting the #9 and #10 pins in the GP Serial I/F, a termination resistance of 100Ω is added between RDA and RDB.

Cable Diagram 5 (RS-232C)

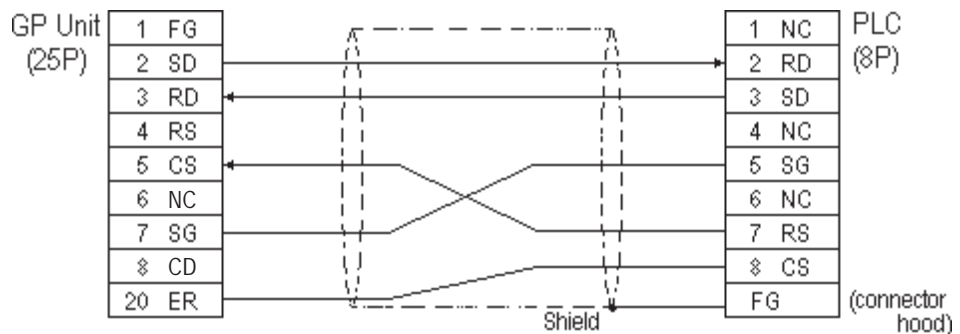

Cable Diagram 6 (RS-232C)

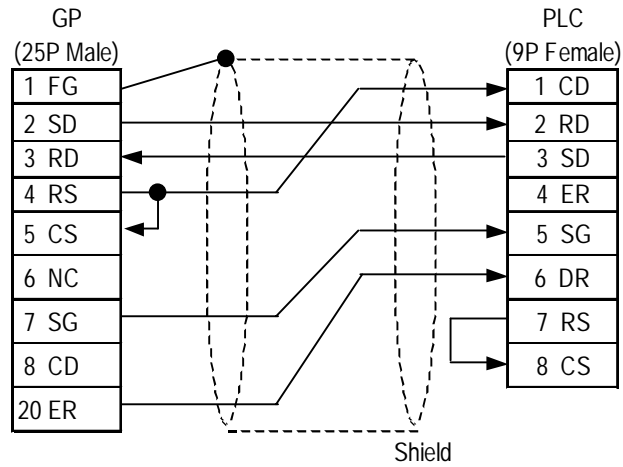

Cable Diagram 7 (RS-422, 4-wire)

- When using Digital's RS-422 connector terminal GP070-CN10-0 adapter

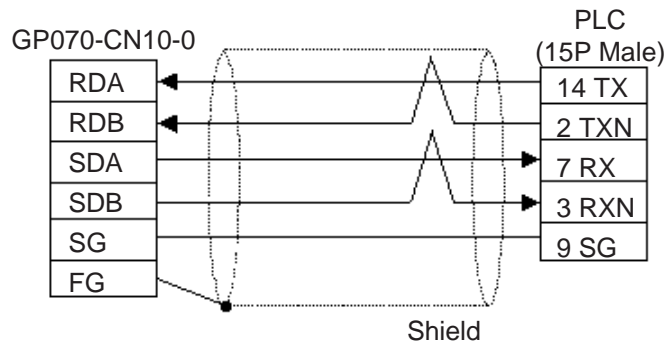

- When making your own cable connections

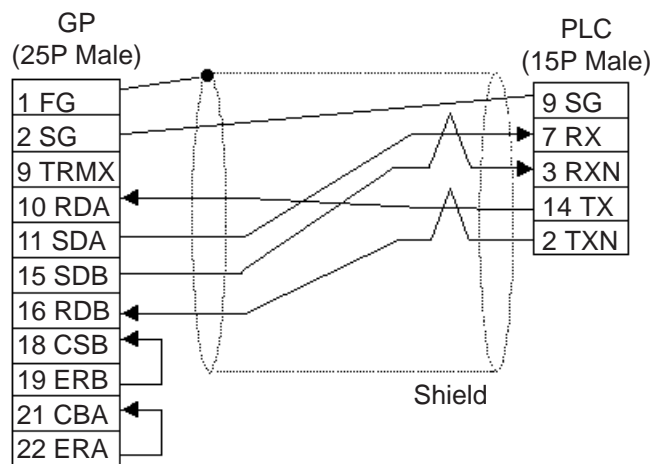















2.5.3 Supported Devices

The following describes the range of devices supported by the GP.

■ HIDIC S10α Series

 Setup System Area here.

Device	Bit Address	Word Address	Particulars	
Input Relay	X000 ~ X7FF	XW000 ~ XW7F0		H/L
Output Relay	Y000 ~ Y77FF	YW000 ~ YW7F0		
Internal Relay	R000 ~ R7FF	RW000 ~ RW7F0		
Global Link	G000 ~ GFFF	GW000 ~ GWFF0		
System Register	S000 ~ SBFF	SW000 ~ SWBF0		
E Word	EW400 ~ EWFFF	EW400 ~ EWFF0		
Event	E000 ~ E0FF	EW000 ~ EW0F0		
Keep Relay	K000 ~ K1FF	KW000 ~ KW1F0		
On-Delay Timer	T000 ~ T1FF	TW000 ~ TW1F0		
One Shot Timer	U000 ~ U07F	UW000 ~ UW070		
Up/Down Counter	C000 ~ C03F	CW000 ~ CW030		
On-Delay Timer (elapsed value)	---	TC000 ~ TC1FF		L/H
On-Delay Timer (setup value)	---	TS000 ~ TS1FF		
One Shot Timer (elapsed value)	---	UC000 ~ UC07F		
One Shot Timer (setup value)	---	US000 ~ US07F		
Up/Down Counter (elapsed value)	---	CC000 ~ CC03F		
Up/Down Counter (setup value)	---	CS000 ~ CS03F		
Data Register	---	DW000 ~ DWFFF		H/L
Work Register	---	FW000 ~ FWBFF		
Extended Register	---	MS000 ~ MSFFF Address on GP-PRO/PBIII		















* 1 Cannot perform data write.

* 2 Point of Contact.

* 3 Access is possible for 4K words of Extended Memory (8 bits per address). The top address of the Extended Memory to be accessed is set in the [SET UP OPERATION SURROUNDINGS] area of the INITIALIZE menu. (Refer to "Extended Memory Top Address Setup.") Be sure to set the address(es) accessed by the GP within the limits of the PLC's specified Extended Memory address area. For PLC Extended Memory address setting procedures, refer to the PLC maker's manual.

■ S10 mini Series

 Setup System Area here.

Device	Bit Address	Word Address	Remarks
External Input	X000 - XFFF	XW000 - XWFF0	 *1
External Output	Y000 - YFFF	YW000 - YWFF0	 *1
Internal Resistor	R000 - RFFF	RW000 - RWFF0	 *1
Global Link Resistor	G000 - GFFF	GW000 - GWFF0	 *1
Event Resistor	E000 - E0FF	EW000 - EW0F0	 *1
Event Resistor	EW400 - EWFFF	EW400 - EWFF0	 *2
Keep Relay	K000 - KFFF	KW000 - KWFF0	 *1
System Resistor	S000 - SBFF	SW000 - SWBF0	 *1*3
On-delay Timer	T000 - T1FF	TW000 - TW1F0	 *1
One-shot Timer	U000 - U0FF	UW000 - UW0FF	 *1
Up-down Counter	C000 - C0FF	CW000 - CW0FF	 *1
On-delay Timer (Current Value)	———	TC000 - TC1FF	
On-delay Timer (Set Value)	———	TS000 - TS1FF	
One-shot Timer (Current Value)	———	UC000 - UC0FF	
One-shot Timer (Set Value)	———	US000 - US0FF	
Up-down Counter (Current Value)	———	CC000 - CC0FF	
Up-down Counter (Set Value)	———	CS000 - CS0FF	
Work Register	———	FW000 - FWBFF	
Data Register	———	DW000 - DWFFF	
Expansion Resistor	———	MS000 - MSFFF	 *4

*1 Because of the PLC specifications, the highest bit has been designated as 0 and the lowest bit as 15. Therefore, when Bit 0 turns ON, “32768” will be written to the top Word.

*2 The higher and lower bit order will be reversed. When EW400 is turned ON, E40F will be turned ON on the PLC.

*3 Data cannot be written.

*4 In expansion memory (1 address = 8 bits), 4K Words can be accessed. Designate the top address of the expansion memory to be accessed, via [Default Settings] - [Set Up Operation Surroundings] (see the following page). The GP’s access address will then be designated within the range of expansion memory address range set up in the PLC. For the detailed information about how to set up the PLC’s expansion memory address range, refer to that PLC’s manual.

Cautions when using HIDIC S10α and S10 mini

◆ **Accessed Extended Memory Address**

Access Address = Top Address + Device Address set by GP-PRO/PBIII for Windows

E.g. When the Top Address = 180000 and the Device Address is MS 1FF;

$$180000 + 3FE = 1803FE$$

Since the PLC uses 8 bits for its extended memory addresses, this number is doubled.

◆ **Extended Memory Top Address Setup**

Specify the extended memory address at the initial setup when the GP is in the OFFLINE mode.

Reference OFFLINE mode → Refer to → User's Manuals (sold separately), Chapter 4 "OFFLINE Mode"



Note: For the input range (values) 0HEX to FE000HEX, be sure to add the offset value (100000HEX) to the range values to create the actual address setting. If, however, the GP does not access Extended Memory, these addresses do not need to be set.

If the GP uses tags or parts to access the PLC's program area, errors in either the PLC or the GP may occur. Therefore, it is recommended that the [Extended Memory Addresses] in an area not used by the PLC.

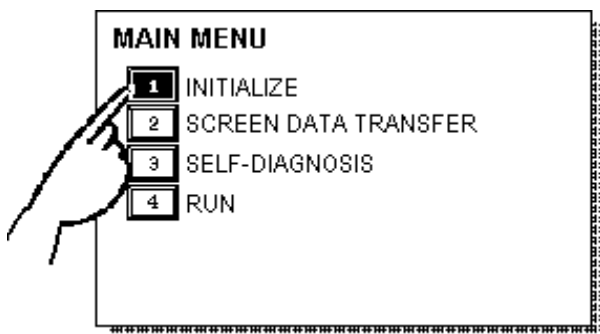

① Touch item #1, INITIALIZE. The INITIALIZE menu will appear.

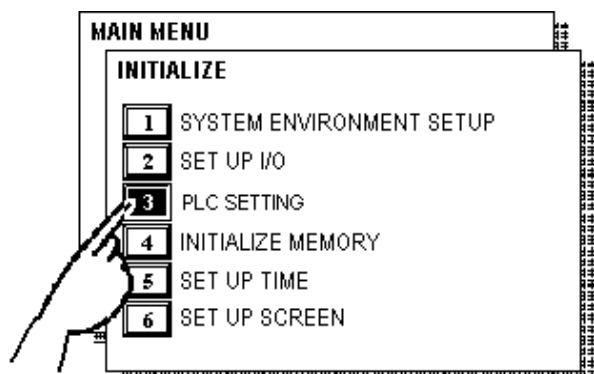

② Touch item #3, PLC SETTING. The PLC SETTING menu will appear.

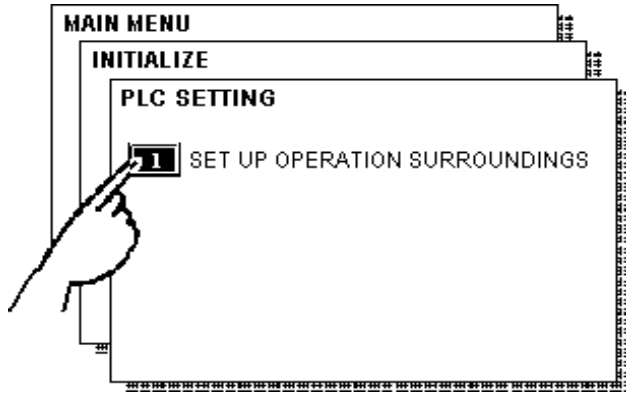

- ③ Touch item #1, SET UP OPERATION SURROUNDINGS. The SET UP OPERATION SURROUNDINGS menu will appear.

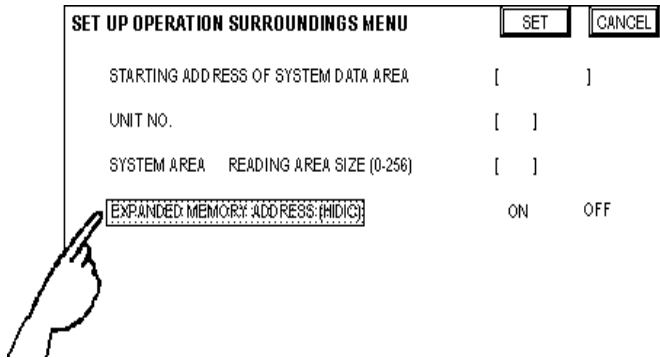

- ④ Touch the “EXPANDED MEMORY ADDRESS (HIDIC)” selection. The selected item is highlighted.

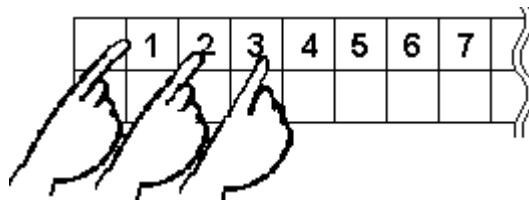

- ⑤ Use the Touch Keys at the bottom of the screens to enter the desired value.
 <Example> When setting the value of 180000, enter [80000].







If the first CPU link (L0000 to L3FFF) and the second CPU link (L10000 to L13FFF) are used with any GP-PRO/PB III for Windows drawing software which is Ver. 1.0 or earlier, enter L00000 to L03FFF for the first CPU link; and enter L100000 to L103FFF for the second CPU link by adding a zero to each one.

If GP-PRO/PB III for Windows Ver. 2.0 or later is used, enter the addresses shown in the previous page's table.

If you upgrade your GP-PRO/PB III for Windows Ver. 1.0 or earlier to Ver. 2.0 or later, your internal data will not be affected. Only the addresses to be entered are different.

■ HIZAC EC Series

 Setup System Area here.

Device	Bit Address	Word Address	Vertical Address	Particulars
External Input	X000 - X015	WX000 - WX014	VX000	 *1 *3 (Only for Vertical Address)
	X020 - X035	WX020 - WX034	VX020	
	X040 - X055	WX040 - WX054	VX040	
	X060 - X075	WX060 - WX074	VX060	
	X080 - X095	WX080 - WX094	VX080	
	X100 - X115	WX100 - WX114	VX100	
	X120 - X135	WX120 - WX134	VX120	
	X140 - X155	WX140 - WX154	VX140	
	X160 - X175	WX160 - WX174	VX160	
X180 - X195	WX180 - WX194	VY180		
External Output	Y200 - Y215	WY200 - WY214	VY200	 *2 *3 (Only for Vertical Address)
	Y220 - Y235	WY220 - WY234	VY220	
	Y240 - Y255	WY240 - WY254	VY240	
	Y260 - Y275	WY260 - WY274	VY260	
	Y280 - Y295	WY280 - WY294	VY280	
	Y300 - Y315	WY300 - WY314	VY300	
	Y320 - Y335	WY320 - WY334	VY320	
	Y340 - Y355	WY340 - WY354	VY340	
	Y360 - Y375	WY360 - WY374	VY360	
Y380 - Y395	WY380 - WY394	VY380		
Internal Output	M400 - M655	WM400 - WM654	VM400 - VM640	 *2  *3 (Only for Vertical Address)
	M700 - M955	WM700 - WM954	VM700 - VM940	
	M960 - M991	WM960 - WM990	VM960 - VM976	
Timer/Counter (contact, or coil)	TC000 - TC095	---	---	
Timer/Counter (elapsed time)	---	TC100 - TC195	---	
Timer/Counter (setup value)	---	TC200 - TC295	---	*4

- * 1 Due to the hardware structure, I/O numbers without the external terminals are OFF during RUN mode.
- * 2 Due to the hardware structure, the I/O numbers without the external terminals will have the same feature as the Internal Output (M).
- * 3 When writing word data, more than two consecutive word addresses cannot be written.
- * 4 Even if you change a value using a T/W/K-tag in the middle of running the PLC, restarting the PLC initializes using the values setup in the ladder program.



A maximum of 108 words from WM400, WM700 can be used as the Read Area. However, Word Addresses from EM960 cannot be used as the Read Area. If any address from EM960 is used as the Read Area, the "PLC COM. ERROR(02:FA)" message will appear.



• **Bit Address**

A bit address (1 point) uses the data area of one byte. The bit address turns the highest bit (b7) on/off in the corresponding data area.

M400	b7	b6	b5	b4	b3	b2	b1	b0
M401	b7	b6	b5	b4	b3	b2	b1	b0

• **Word Address**

Word address uses the data area of 2 bytes. For example, selecting M400 causes the setup of the next address, M401, as well.

M400	b15	b14	b13	b12	b11	b10	b9	b8
M401	b7	b6	b5	b4	b3	b2	b1	b0

• **Vertical Address**

Uses the highest bit (b7) of 16 consecutive addresses to form word data.

M400	b7	b6	b5	b4	b3	b2	b1	b0	M400	b0
M401	b7	b6	b5	b4	b3	b2	b1	b0	M401	b1
M415	b7	b6	b5	b4	b3	b2	b1	b0	M415	b15

The Vertical Address can only use numbers divisible by 16.

• **The Internal Output (bit address) functions as listed below.**

M400~M655	Data not preserved when powered off
M700~M955	Data preserved when powered off
M960~M991	Special Area

2.5.4 Environment Setup

The following tables list Digital's recommended PLC and GP communication settings.

■ HIDIC S10 α Series

GP Setup		Upper Computer I/F, Upper Link Module Setup	
Baud Rate	19200 bps	Baud Rate	19200 bps ^{*1}
Data Length	8 bits (fixed)	---	
Stop Bit	1 bit (fixed)	---	
Parity Bit	Odd (fixed)	---	
Data Flow Control	ER Control	---	
Communication Format	4-wire type	---	
Unit No.	0	---	

**1 LWP000 is fixed (setup is unnecessary).*

■ S10 mini Series

GP Setup		Upper Computer I/F, Upper Link Module Setup	
Baud Rate	19200 bps	Baud Rate	19200 bps
Data Length	8 bits (fixed)	---	
Stop Bit	1 bit (fixed)	---	
Parity Bit	Odd (fixed)	---	
Data Flow Control	ER Control	---	
Communication Format	RS-232C	Communication Format Protocol setting switch	RS-232C 8 or 9 ^{*1}
Unit No.	0	---	

**1 When using CN1 and CN2 simultaneously, set them so that their numbers will not duplicate.*

■ **HIDIC H Series** (using COMM module)

Procedure 1 for transmission control

GP Setup		COMM Module Setup	
Baud Rate	19200 bps	Baud Rate	19200 bps
Data Length	7 bits	Data Bit	7 bits
Stop Bit	1 bit	Stop Bit	1 bit
Parity Bit	Even	Parity Bit	Even
Data Flow Control	ER Control	---	
Communication Format (RS-232C)	RS-232C	Communication Format (RS-232C)	RS-232C
Communication Format (RS-422)	4-wire type	Communication Format (RS-422) Mode Switch	RS-422 2
---		Sum Check	Yes
Unit No. (RS-232C)	0	Station No. (RS-232C)	0
Unit No. (RS-422)	1	Station No. (RS-422)	1

■ **HIDIC-H Series/COMM-2H** Procedure 2 for transmission control

GP Setup		COMM Module Setup	
Baud Rate	19200 bps	Baud Rate	19200 bps
Data Length	7 bits	Data Bit	7 bits
Stop Bit	1 bit	Stop Bit	1 bit
Parity Bit	Even	Parity Bit	Even
Data Flow Control	ER Control	---	
Communication Format (RS-232C)	RS-232C	Communication Format (RS-232C) Mode Switch	RS-232C 9
Communication Format (RS-422)	4-wire type	Communication Format (RS-422) Mode Switch	RS-422 9
---		Sum Check	Yes
Unit No. (RS-232C)	0	Station No. (RS-232C)	0
Unit No. (RS-422)	1	Station No. (RS-422)	1

■ **HIDIC-H Series (CPU Direct Connection)**

GP Setup		PLC Setup	
Baud Rate	4800 bps ^{*1}	Baud Rate	4800 bps ^{*1}
Data Length	7 bits	Data Bit	7 bits
Stop Bit	1 bit	Stop Bit	1 bit
Parity Bit	Even	Parity Bit	Even
Data Flow Control	ER Control	Data Flow Control	DTR Control
Communication Format	RS-232C	Communication Format	RS-232C
---		Operation Mode	Transmission Control Procedure 1
Unit No.	0	Station No.	0

**1 With some CPUs, a baud rate of 19200bps or 38400bps can be used. Refer to "2.5.1 System Structure" for details.*

■ **HIDIC EH150 Series**

GP Setup		PLC Setup	
Baud Rate	19200 bps	Baud Rate ^{*1}	19200 bps
Data Length	7 bits	Data Bit	7 bits
Stop Bit	1 bit	Stop Bit	1 bit
Parity Bit	Even	Parity Bit	Even
Data Flow Control	ER Control	---	
Communication Format	RS-232C or RS-422	Mode Setting Switch	SW1 : OFF (Normal mode)
			SW5 : ON (Exclusive mode)
			SW7 : OFF (Normal Operation mode)
			SW8 : OFF (Normal Operation mode)
		Port ON/OFF Switch	ON (Programmer Connection)
		Exclusive Port Setting ^{*2}	Special Internal Output WRF037 ^{*3}
Unit No.	0	---	

**1 Set the Mode Setting Switch. (SW3, 4 : Port 1, SW6 : Port 2)
When using Prot 2, the cable diagram needs to be changed.*

Reference refer to 2.5.1 System Structure

**2 Set when using EH-CPU448.*

**3 Depending on the your Interface and Procedure, varies as shown below.
RS-232C Procedure 1 : 8000H
RS-232C Procedure 2 : C000H
RS-422 Procedure 1 with unit No. : A1xxH (xx indicates GP's Unit No.)
RS-422 Procedure 2 with unit No. : E1xxH (xx indicates GP's Unit No.)*

**4 Only EH-CPU448's serial port1 can be set.*

■ HIZAC EC Series

GP Setup		PLC Setup	
Baud Rate	9600 bps	Baud Rate	9600 bps
Data Length	7 bits	Data Bit	7 bits
Stop Bit	1 bit	Stop Bit	1 bit
Parity Bit	Even	Parity On/Off Parity	On Even
Data Flow Control	ER Control	Data Flow Control	DTR Control
Communication Format	RS-232C	Communication Mode	COM2 Mode (Command mode)
---		Sum Check	Yes
Unit No.	0 (fixed)	---	





2.6 Sharp

2.6.1 System Structure

The following describes the system structure for connecting the GP to Sharp PLCs.

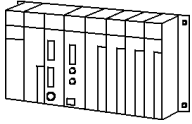
Reference The Cable Diagrams mentioned in the following table are listed in the section titled "2.6.2 Cable Diagrams".

■ New Satellite JW Series (using Link I/F)

CPU	Link I/F	Cable Diagram	GP
	 Link I/F		
JW20	Link I/F on CPU unit *1	RS-232C (Cable Diagram 1)	GP Series
	JW-21CM	RS-422 4-wire type (Cable Diagram 3) RS-422 2-wire type (Cable Diagram 4)	
JW-32CUH JW-32CUH1 JW-33CUH3	Link I/F on CPU unit	RS-232C Connected to PG/COMM2 port (Cable Diagram 2)	
		RS-422 (4 wire type Connected to PG/COMM1 port or PG/COMM2 port (Cable Diagram 5)	
	JW-21CM	RS-422 4-wire type (Cable Diagram 3)	
JW50	JW-10CM	RS-422 4-wire type (Cable Diagram 3)	
	ZW-10CM	RS-422 4-wire type (Cable Diagram 3) RS-422 2-wire type (Cable Diagram 4)	
JW70, JW100	Link I/F on CPU unit *1	RS-232C (Cable Diagram 1)	
	JW-10CM	RS-422 4-wire type (Cable Diagram 3)	
	ZW-10CM	RS-422 4-wire type (Cable Diagram 3) RS-422 2-wire type (Cable Diagram 4)	

*1 Connect to the CPU Module's (JW-22CU, JW-70CU, JW-100CU) communication port.



Places noted as RS-422 can also use RS-485 on the PLC side.

2.6.2 Cable Diagrams

The cable diagrams illustrated below and the cable diagrams recommended by Sharp may differ, however, using these cables for your PLC operations will not cause any problems.



Ground your PLC's FG terminal according to your country's applicable standard. For details, refer to the corresponding PLC manual.



- **Connect the FG line of the Shield cable to either the GP or PLC, depending on your environment. When using a connector hood and grounding the FG line, be sure to use an electrical conductor. The following connection diagrams show examples for connecting a shielded cable to the PLC.**
- **For the RS-232C connection, use a cable length less than 15m.**
- **If a communications cable is used, it must be connected to the SG (signal ground).**
- **For the RS-422 connection, refer to Sharp's PLC manual for the cable length.**

Cable Diagram 1 (RS-232C)

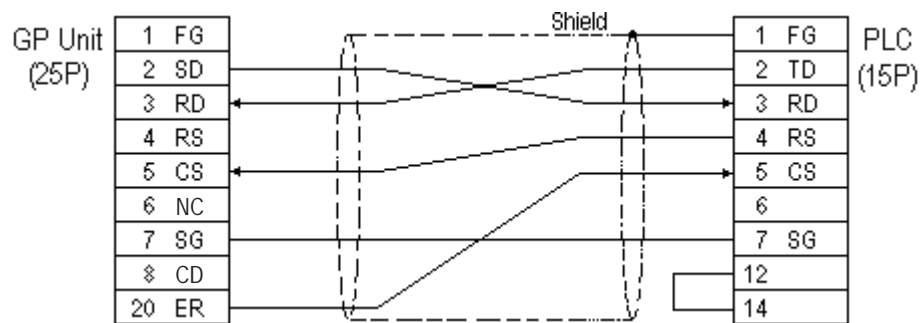

Fujikura Densen's 7P*7/0.18 57VV-SB is recommended for the connection cable.

Cable Diagram 2 (RS-232C)



Do not use pin Nos. 14 and 15 for connection with the GP since their voltage is +5V.

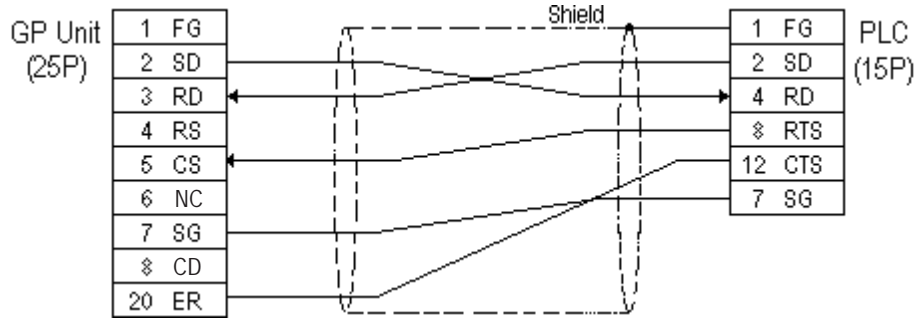

Cable Diagram 3 (RS-422)



Turn on the PLC's Termination Resistor switch.

- When using Digital's RS-422 connector terminal adapter GP070-CN10-0

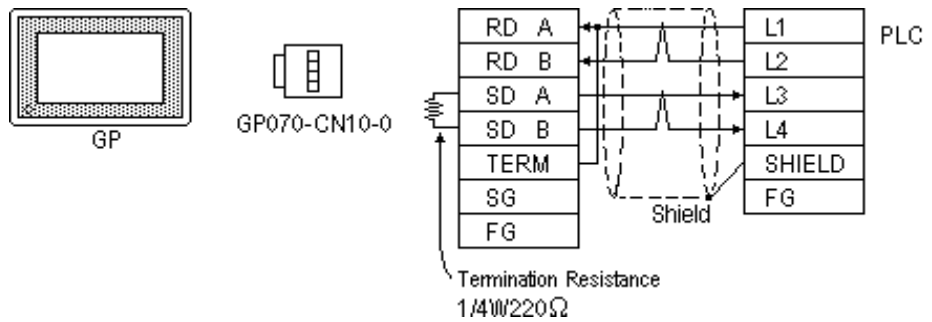

- When using Digital's RS-422 cable, GP230-IS11-0

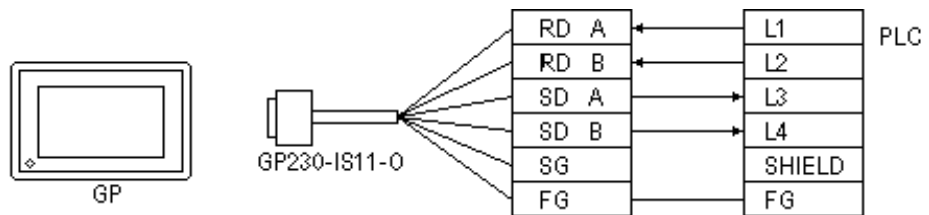

- When making your own cable connections

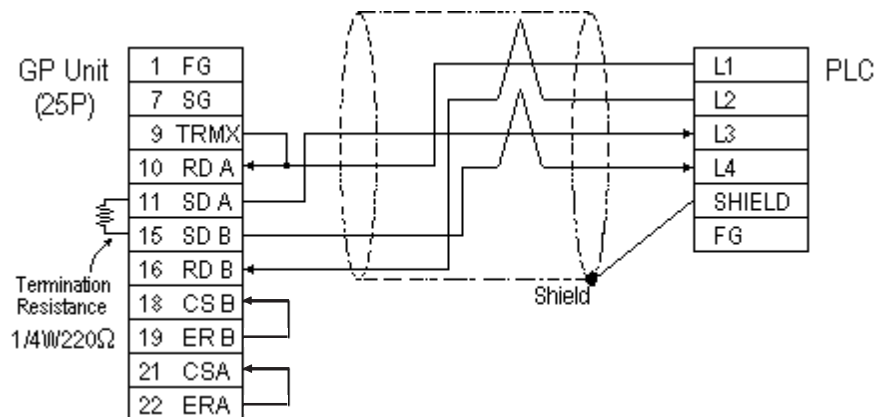



- When making your own cable connections, we recommend using Hitachi Densen's CO-SPEV-SB(A)3P*0.5 cable.
- When connecting the #9 and #10 pins in the GP Serial I/F, a termination resistance of 100Ω is added between RDA and RDB.

Cable Diagram 4 (RS-422)



Turn on the Termination Resistor switch, on the PLC.

- When using Digital's RS-422 connector terminal adapter GP070-CN10-0

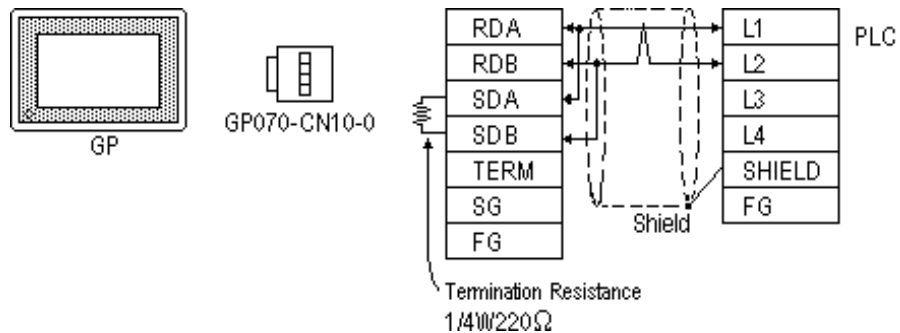

Connect terminals SD A and RD A to terminal base L1, and SD B and RD B to terminal block's L2 line.

- When using Digital's RS-422 cable, GP230-IS11-0

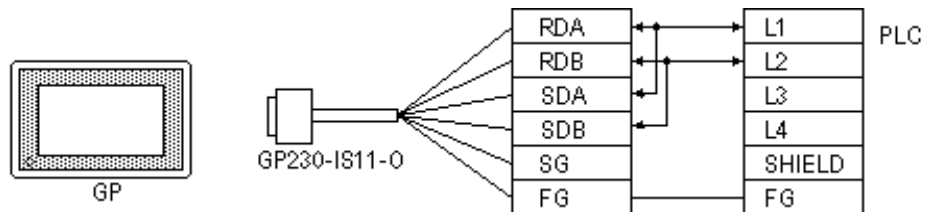

- Connect terminals SD A and RD A to terminal base L1, and SD B and RD B to terminal block's L2 line.

- When making your own cable connections

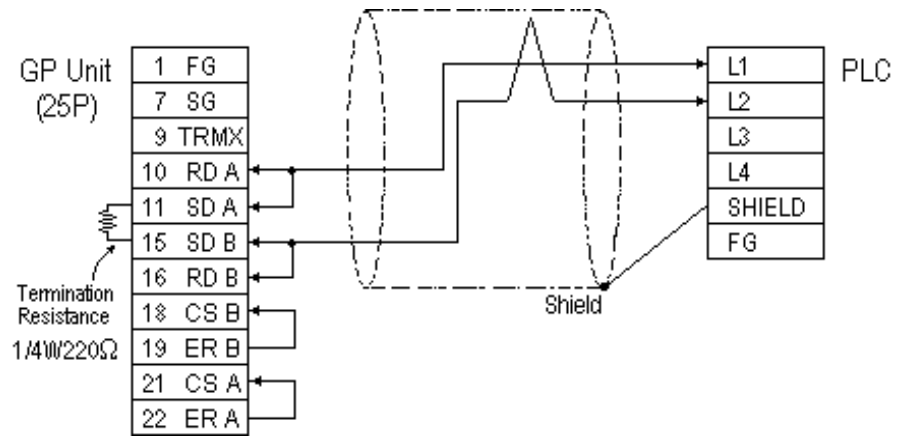

- When making your own cable connections, we recommend using Hitachi Densen's CO-SPEV-SB(A)3P*0.5 cable.
- When connecting the #9 and #10 pins in the GP Serial I/F, a termination resistance of 100Ω is added between RDA and RDB.

Cable Diagram 5 (RS-422)



- Do not connect anything to pin Nos. 2, 4, 8, and 12.
- Do not use pin Nos. 14 and 15 for connection with the GP since their voltage is +5V.

- When using Digital's RS-422 connector terminal adapter GP070-CN10-0

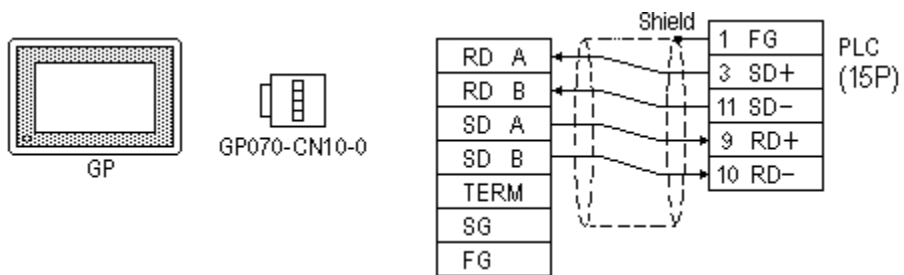

- When using Digital's RS-422 cable, GP230-IS11-0

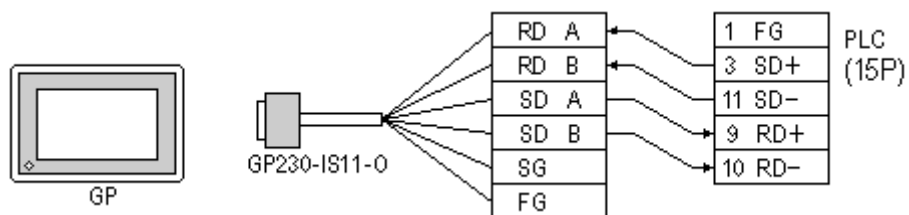

- When making your own cable connections

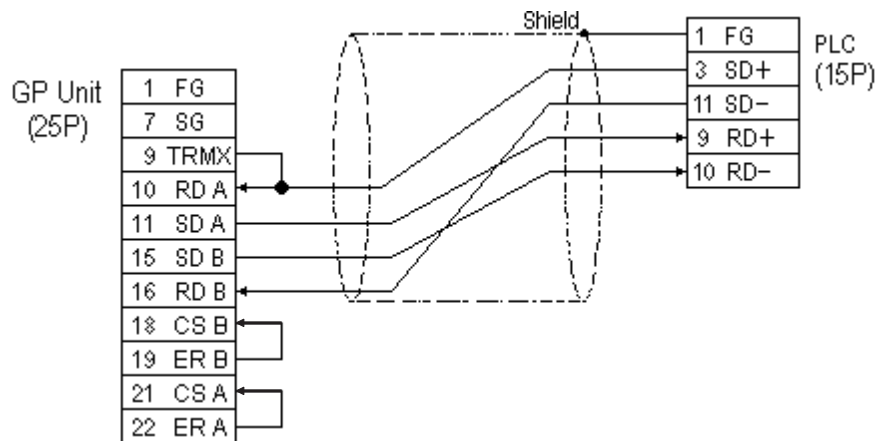







Note: Our recommendation for making your own cable is Hitachi's CO-SPEV-SB(A) 3P0.5mm².

2.6.3 Supported Devices

The following describes the range of devices supported by the GP.

■ New Satellite JW Series

 Setup System Area here.

Device	Bit Address	Word Address	Particulars	
Relay	00000 - 15777	A0000 - A1576 (□0000 - □1576)		L/H
Timer (contact)	T0000 - T0776	---		
Counter (contact)	C0000 - C0776	---		
Timer/Counter (current value)	---	T0000 - T0777		
		B0000 - B3776 (b0000 - b3776)	 	
Register	---	09000 - 09776	 	
		19000 - 19776		
		29000 - 29776		
		39000 - 39776		
		49000 - 49776		
		59000 - 59776		
		69000 - 69776		
		79000 - 79776		
		89000 - 89776		
		99000 - 99776		
File Register	---	1000000 - 717776	  ¹	

* 1 The file register consists of a file number and an address.

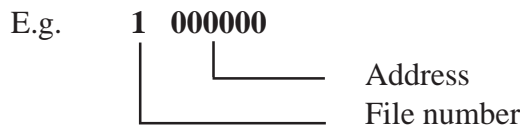

The PLC manual uses the values displayed in brackets for the Relay and Timer/Counter (current value) (B) word addresses; as a result, when entering, be sure to use **AXXXX** or **BXXXX**.



That the range of addresses that can be used will vary depending on the type of PLC.

■ New Satellite JW-32CUH Series

 Setup System Area here.

Device	Bit Address	Word Address	Particulars		
Relay	00000 ~ 15777	A0000 ~ A1576 (□0000 ~ □1576)	÷2		
	20000 ~ 75777	A2000 ~ A7576 (□2000 ~ □7576)			
Timer (contact)	T0000 ~ T1777	---			
Counter (contact)	C0000 ~ C1777	---			
Timer/Counter (current value)	---	B0000 ~ B3776 (b0000 ~ b3776)	÷2		
Register	---	09000 ~ 09776	÷2 [Bit] 5		
	---	19000 ~ 19776			
	---	29000 ~ 29776			
	---	39000 ~ 39776			
	---	49000 ~ 49776			
	---	59000 ~ 59776			
	---	69000 ~ 69776			
	---	79000 ~ 79776			
	---	89000 ~ 89776			
	---	99000 ~ 99776			
	---	E0000 ~ E0776			
	---	E1000 ~ E1776			
	---	E2000 ~ E2776			
	---	E3000 ~ E3776			
	---	E4000 ~ E4776			
	---	E5000 ~ E5776			
	---	E6000 ~ E6776			
	---	E7000 ~ E7776			
	File Register 1	---		1000000 ~ 1037776	÷2 [Bit] 5 ^{*1}
	File Register 2	---		2000000 ~ 2177776	÷2 [Bit] 5 ^{*1}

L/H

* 1 The file register consists of a file number and an address.

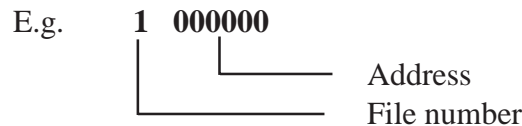

The PLC manual uses the values displayed in brackets for the Relay and Timer/Counter (current value) (B) word addresses; as a result, when entering, be sure to use **AXXXX** or **BXXXX**.



The range of addresses that can be used will vary depending on the type of PLC.

■ New Satellite JW Series (JW-33CUH3)

 Setup System Area here.

Device	Bit Address	Word Address	Particulars
Relay	00000 - 15777	A0000 - A1576 (□0000 - □1576)	⌈ ÷ 2 ⌋
	20000 - 75777	A2000 - A7576 (□2000 - □7576)	
Timer (contact)	T0000 - T1777	—	
Counter(contact)	C0000 - C1777	—	
Timer/Counter (current value)	—	B0000 - B3776 (b0000 - b3776)	⌈ ÷ 2 ⌋
Register	—	09000 - 09776	⌈ ÷ 2 ⌋ [Bit] 5
	—	19000 - 19776	
	—	29000 - 29776	
	—	39000 - 39776	
	—	49000 - 49776	
	—	59000 - 59776	
	—	69000 - 69776	
	—	79000 - 79776	
	—	89000 - 89776	
	—	99000 - 99776	
	—	E0000 - E0776	
	—	E1000 - E1776	
	—	E2000 - E2776	
	—	E3000 - E3776	
	—	E4000 - E4776	
	—	E5000 - E5776	
	—	E6000 - E6776	
—	E7000 - E7776		
File Register 1	—	1000000 - 1037776	⌈ ÷ 2 ⌋ [Bit] 5
File Register 2	—	2000000 - 2177776	
File Register 3	—	3000000 - 3037776	
File Register 10-1F	—	F1000000 - F1F17776	
File Register 20-2C	—	F2000000 - F2C17776	

L/H

* 1

* 1 The file register consists of a file number and an address.

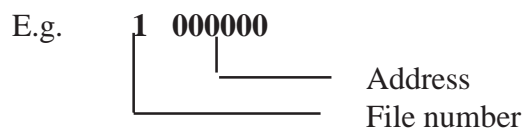

The PLC manual uses the values displayed in brackets for the Relay and Timer/Counter (current value) (B) word addresses; as a result, when entering, be sure to use AXXXX or BXXXX.



Note: The range of addresses that can be used will vary depending on the type of PLC.

2.6.4 Environment Setup

The following lists Digital's recommended PLC and GP communication settings.

■ New Satellite JW Series (Using Link I/F on CPU unit)

GP Setup		Communication Port Setup	
Baud Rate ^{*1}	9600 bps	Baud Rate	9600 bps
Data Length	7 bits	Data Bit	7 bits
Stop Bit	2 bits	Stop Bit	2 bits
Parity Bit	Even	Parity Bit	Even
Data Flow Control	ER Control	---	
Communication Format	RS-232C	---	
Communication Format (4-wire)	4 wire type	---	
Communication Format (2-wire)	2 wire type	---	
Unit No.	1	Station Number	1

■ New Satellite JW Series (Using Link I/F)

GP Setup		Link Unit Setup	
Baud Rate ^{*1}	19200 bps	Baud Rate	19200 bps
Data Length	7 bits (fixed)	Data Bit	7 bits (fixed)
Stop Bit	2 bits (fixed)	Stop Bit	2 bits (fixed)
Parity Bit	Even	Parity Bit	Even
Data Flow Control	ER Control	---	
Communication Format (4-wire)	4 wire type	Comm Mode (SIO Line#) (4-wire type)	4 wire type
Communication Format (2-wire)	2 wire type	Comm Mode (SIO Line#) (4-wire type)	2 wire type
---		Function Setup Switch (S0)	Computer Link
Unit No.	1	Station Number	1

*1 115200bps can be used when the JW-32CUH1 or the JW-33CUH3 is used.





2.7 Matsushita Electric Works

2.7.1 System Structure

The following describes the system structure for connecting the GP to Matsushita Electric Works PLCs.

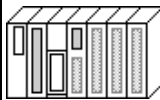
Reference The Cable Diagrams mentioned in the following tables are listed in the section titled "2.7.2 Cable Diagrams".

MEWNET Series (using Link Unit)

CPU	Link I/F	Cable Diagram	Cables	GP
	 Computer Communication Unit (C.C.U.)			
FP1 (C24, C40C)	CPU unit Upper Link I/F *1	RS-232C (Cable Diagram 1) *5	Matsushita AFB85813 *4	GP Series
FP10SH FP2	CPU unit Upper Link I/F *2	RS-232C (Cable Diagram 1)	Matsushita AFB85813 *4	
FP3	AFP3462			
FP5	AFP5462			
FP10(S)	AFP3462			
	Upper Link I/F on CPU *2			
FP-M	Upper Link I/F on CPU *3	RS232C (Cable Diagram 1) *5		
FP0	Upper Link I/F on CPU *1	RS232C (Cable Diagram 6)		

* 1 Connect to the RS-232C port.



* 2 Connect to COM port.

* 3 Connect to Serial port connector.

* 4 Due to the size of its connector case, this cable cannot be used for GP-270 , GP-370 , GP-377, GP-377R series.

*5 Use <Cable Diagram 2 > if the PLC's version is 2.6 or older.

■ MEWNET Series (using CPUdirect connection)

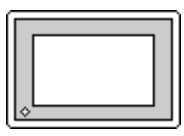
CPU	Adapter	Cable Diagram	Cables	GP
		←————→		
FP1 ^{*1}	Matsushita Electric Works' RS-422/232C terminal changer AFP8550 adapter ^{*2}	RS-422 (Cable Diagram 3)		GP Series
		RS-232C (Cable Diagram 4)		
FP-M ^{*3}		RS-232C (Cable Diagram 5)		
FP0 ^{*4} FP2 ^{*1}		RS-232C (For cable diagram, refer to Matsushita's FP pc M5 type (AFC8513) users manual)	Matsushita's FP personal computer M5 type (AFC8513)	

- * 1 Connect to the Programming Tool connector.
- * 2 It is necessary to connect the RS-422/RS-232C adapter with the PLC using Matsushita's FP1 peripheral AFP15205 connection programmable cable .
- * 3 Connect to the Program connector.
- *4 Connect to the Tool port.

2.7.2 Cable Diagrams

The cable diagrams illustrated below and the cable diagrams recommended by Matsushita Electric Works may differ, however, using these cables for your PLC operations will not cause any problems.



Ground your PLC's FG terminal according to your country's applicable standard. For details, refer to the corresponding PLC manual.



- **Connect the FG line of the Shield cable to either the GP or PLC, depending on your environment. When using a connector hood and grounding the FG line, be sure to use an electrical conductor.**
- **For the RS-232C connection, use a cable length less than 15m.**
- **If a communications cable is used, be sure to connect the SG (signal ground).**
- **For the RS-422 connection, refer to Matsushita's PLC manual for the cable length.**

Cable Diagram 1 (RS-232C)

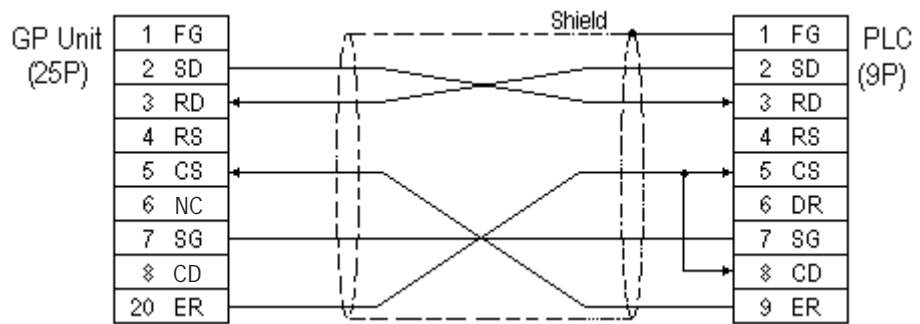

Cable Diagram 2 (RS-232C)

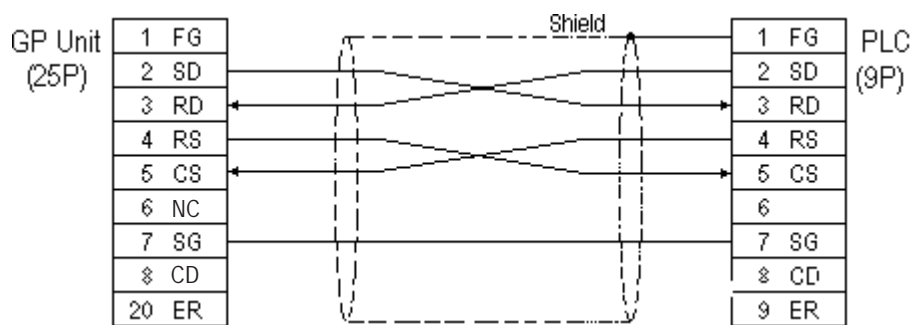

Cable Diagram 3 (RS-422)



You can use Hirose's circular HR212-10P-8P for the PLC connector.

- When using Digital's RS-422 connector terminal adapter GP070-CN10-0

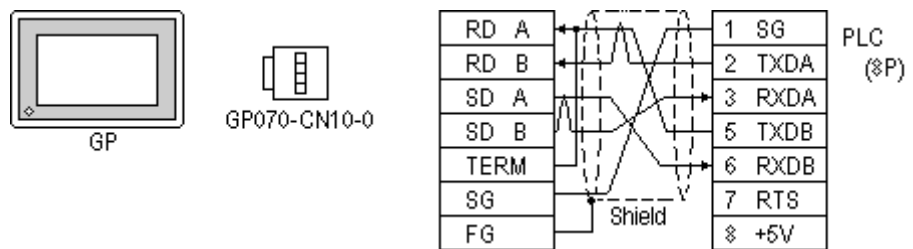

- When using Digital's RS-422 cable, GP230-IS11-0

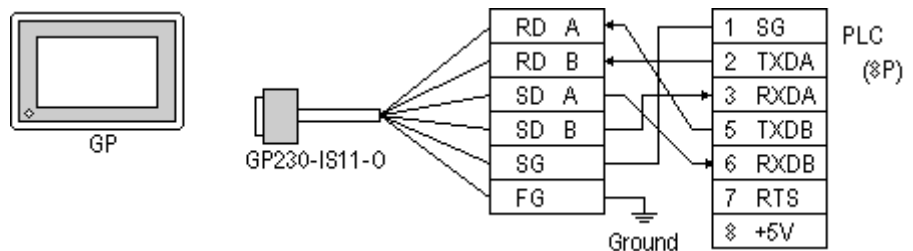

- When making your own cable connections

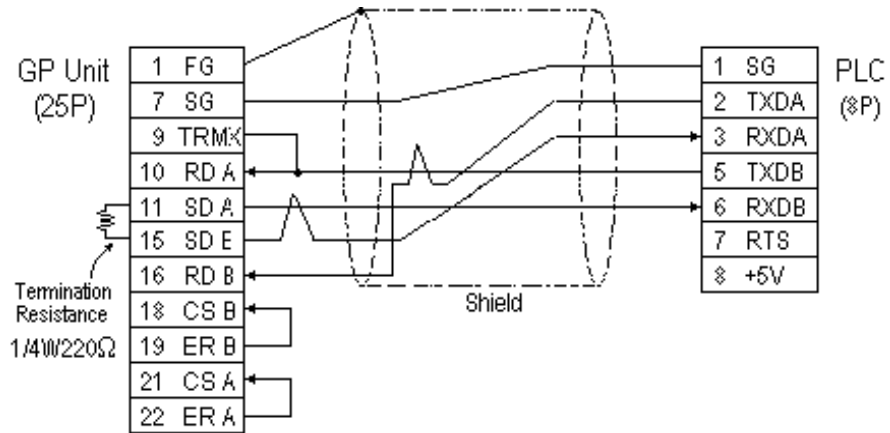

Note: When connecting the #9 and #10 pins in the GP Serial I/F, a termination resistance of 100Ω is added between RDA and RDB.

Cable Diagram 4 (RS-232C)

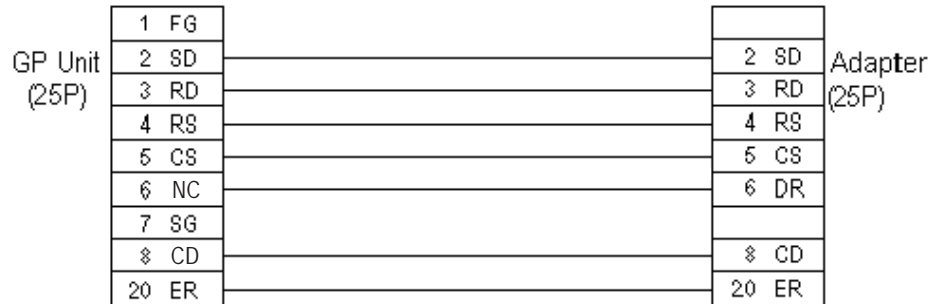

Cable Diagram 5 (RS-232C)

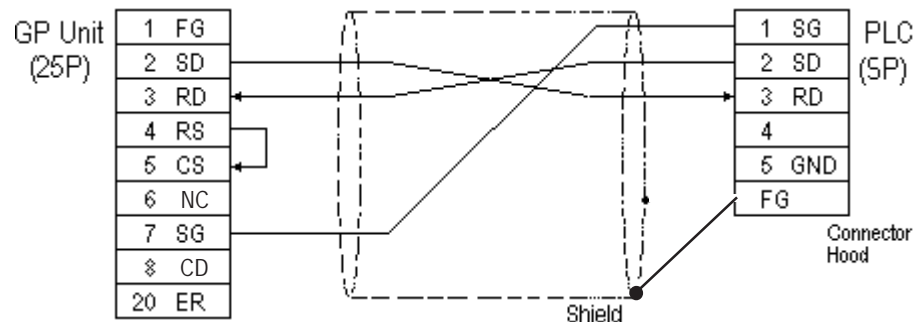

Cable Diagram 6 (RS-232C)

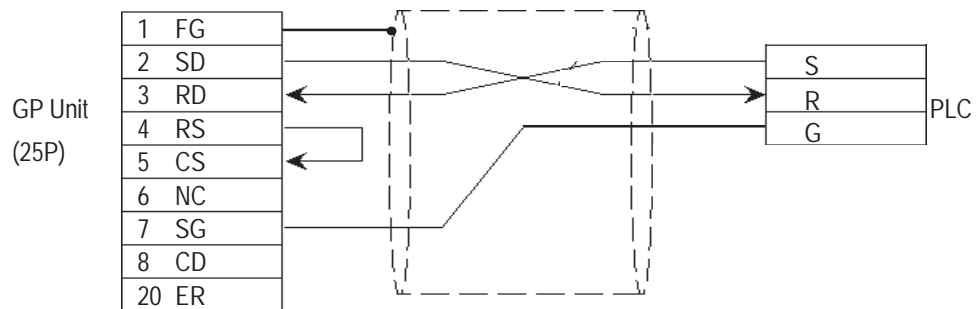

2.7.3 Supported Devices

The following describes the range of devices supported by the GP.

■ MEWNET Series

 Setup System Area here.

Device	Bit Address	Word Address	Particulars
Input Relay	X0000 - X511F	WX000 - WX511	*1
Output Relay	Y0000 - Y511F	WY000 - WY511	
Internal Relay	R0000 - R886F	WR000 - WR886	
Link Relay	L000 - L639F	WL000 - WL639	
Special Relay	R9000 - R910F	WR900 - WR910	*1
Timer (contact)	T0000 - T3071	---	*1
Counter (contact)	C 0000 - C 3071	---	*1
Timer/Counter (elapsed time)	---	EV0000 - EV3071	*1
Timer/Counter (setup value)	---	SV0000 - SV3071	*1
Data Register	---	DT0000 - DT10239	Bit 5 *2
Link Register	---	Ld0000 - Ld8447	Bit 5
File Register	---	FL00000 - FL32764	Bit 5
Special Data Register	---	DT90000-DT90511	Bit 5 *3

L/H

*1 Cannot perform data write.

*2 Some CPU types use this device's word address DT09000 and higher as the Special Data Register.

*3 Only the FP10SH, FP10S, FP10 and FP2 can use this device.



Note: When using the Timer and Counter with FP-M, setup each range in the System Register.



Important: Some CPU devices also have extensions, but only the device ranges shown here can be used.

◆ Monitor Set-up

With the MEWNET-FP series, be sure to change the GP to offline mode before inputting the initial Monitor settings.

Reference Offline mode -> refer to each Users' manual, Chapter 4 Offline Mode



[Monitor is Registered] is preinstalled as the initial value.

When a PLC has 2 or more communication units (CCUs) installed with one CPU, and each of those CCUs is connected to a GP, be sure this setting is [OFF].

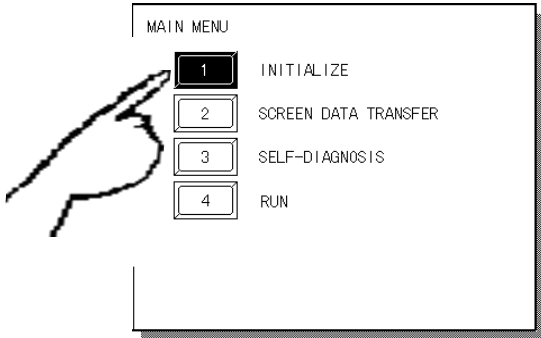

① Touch item #1, INITIALIZE. The INITIALIZE menu will appear.

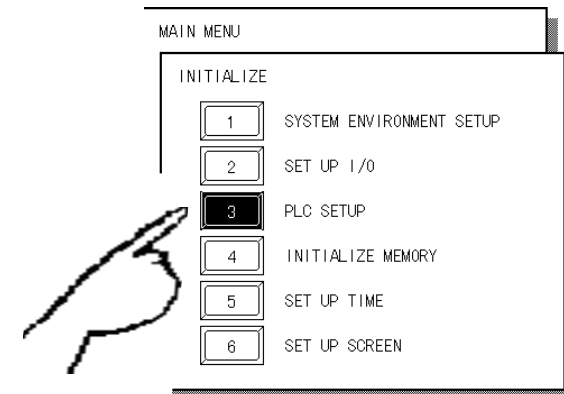

② Touch item #3, PLC SETUP. The PLC SETTING menu will appear.

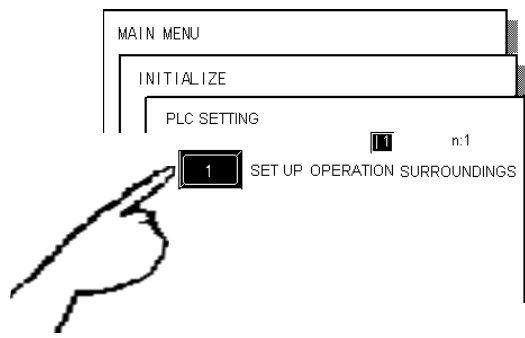

③ Touch selection [1:1] and then item #1, SET UP OPERATION SURROUNDINGS. The selected option is then highlighted.

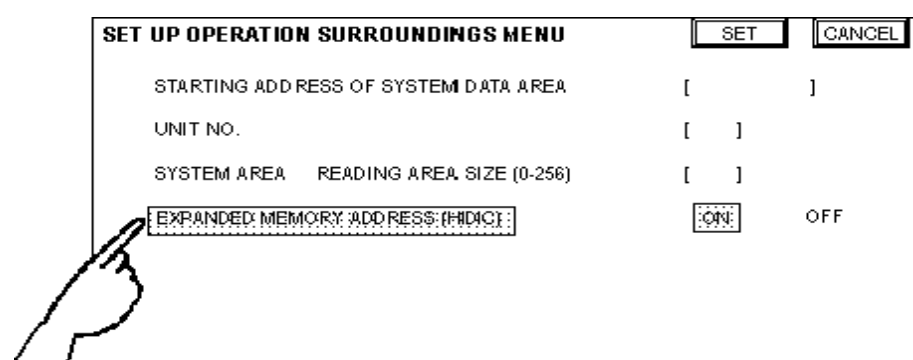

④ Touch MONITOR REGISTER and the text will change to reverse video to show it has been selected.

⑤ When the PLC has only a single (1) communication unit (CCU), which is attached to a single GP, select [ON]. When a PLC has 2 or more communication units (CCUs) installed with one CPU, and each of the CCUs is connected to a GP, select [OFF].



2.7.4 Environment Setup

The following lists Digital's recommended PLC and GP communication settings.

■ FP1 (using CPU Upper Link I/F)

GP Setup		Computer Communication Unit Setup	
Baud Rate	19200 bps	Baud Rate	19200 bps
Data Length	8 bits	Data Bit	8 bits
Stop Bit	1 bit	Stop Bit	1 bit
Parity Bit	Odd	Parity Bit	Odd
Data Flow Control	ER Control		---
Communication Format	RS-232C		---
	---	RS-232C port Operation Select	1 (Computer Link)
	---	RS-422 port Unit No.	1
Unit No.	1	Unit No.	1

■ FP1 (CPU Direct Connection)

GP Setup		Computer Communication Unit Setup	
Baud Rate	19200 bps		---
Data Length	8 bits (fixed)		---
Stop Bit	1 bit (fixed)		---
Parity Bit	Odd (fixed)		---
Data Flow Control	ER Control		---
Communication Format	4-wire type ^{*1}		---
	---	RS-232C Port Operation Selection	1 (computer link)
	---	RS-422 Port Unit No.	1
Unit No.	1 (fixed)		---

*1 If an RS-422/232C conversion adapter is in use, set the communication format to "RS-232C".

■ **FP3/FP5/ FP10(S)** (When using Computer Communication Unit)

GP Setup		Computer Communication Unit Setup	
Baud Rate	19200 bps	Baud Rate	19200 bps
Data Length	8 bits	Data Bit	8 bits
Stop Bit	1 bit	Stop Bit	1 bit
Parity Bit	Odd	Parity Bit	Odd
Data Flow Control	ER Control	Control Signal *1	Make CS/CP ineffective
Communication Format	RS-232C	---	
Unit No.	1	Station No.	1

*1 The FP-10(S) does not have the Control Signal setting.

■ **FP10(S) /FP10SH /FP2**(When using COM Port)

GP Setup		COM Port Setup	
Baud Rate	19200 bps	Baud Rate	19200 bps *1
Data Length	8 bits	Data Bit	8 bits
Stop Bit	1 bit	Stop Bit	1 bit
Parity Bit	Odd	Parity Bit	Odd
Data Flow Control	ER Control	---	
Communication Format	RS-232C	---	
Unit No.	1	Unit No.	1

*1 The FP10SH can also send data at 115200bps.

■ **FP2** (CPU Direct Connection)

GP Setup		Tool Port Setup	
Baud Rate	19200bps	Baud Rate	19200bps
Data Length	8bit	Run Mode Setting Switch	SW1:OFF
Stop Bit	1bit	Data Length	8bit
Parity Bit	Odd	_____	
Data Flow Control	ER Control	_____	
Communication Format	RS-232C	_____	
Unit No.	1	Unit No.	1
_____		Modem Connection	No Connection

■ **FP-M (When using Serial Port Connector)**

GP Setup		FPM Setup	
Baud Rate	19200 bps	Baud Rate	19200 bps
Data Length	8 bits	Data Bit	8 bits
Stop Bit	2 bits	Stop Bit	2 bits
Parity Bit	None	Parity Bit	None
Data Flow Control	ER Control	Start code	No STX
		End code	CR
Communication Format	RS-232C	Communication Format	RS-232C
---		Selection of serial port operation	1 (computer link)
Unit No.	1	Station number	1

■ **FP-M (When using a Programmable Connector)**

GP Setup		FP-M Setup	
Baud Rate	19200 bps	Baud Rate	19200 bps
Data Length	8 bits	Data Bit	8 bits
Stop Bit	1 bit (fixed)	---	
Parity Bit	Odd (fixed)	---	
Data Flow Control	ER Control	---	
Communication Format	RS-232C	---	
Unit No.	1	Station number	1

■ **FPO (Using Link I/F on CPU)**

GP Setup		FPO Setup	
Baud Rate	9600bps	Baud Rate	9600bps
Data Length	8bit	Data Length	8bit
Stop Bit	1bit	Stop Bit	1bit
Parity Bit	Odd	Parity Bit	Odd
Data Flow Control	ER Control	Data Flow Control	ER Control
Unit No.	1	Unit No.	1

■ **FPO (CPU Direct connection)**

GP Setup		FPO Setup	
Baud Rate	9600bps	Baud Rate	9600bps
Data Length	8bit	Data Length	8bit
Stop Bit	1bit (fixed)	Stop Bit	-----
Parity Bit	Odd (fixed)	Parity Bit	-----
Data Flow Control	ER Control	Data Flow Control	ER Control
Unit No.	1	Unit No.	1



2.8 Yokogawa Electric

2.8.1 System Structure

The following describes the system structure for connecting the GP to Yokogawa Electric Corp. PLCs.

Reference The Cable Diagrams mentioned in the following tables are listed in the section titled "2.8.2 Cable Diagrams".

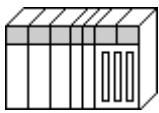
■ FACTORY ACE Series/FA500 (using Link I/F)

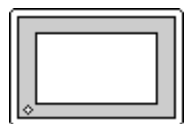
CPU	Link I/F	Cable Diagram	Cables	GP
				
FA500	LC01-ON	RS-232C (Cable Diagram 1)	Digital's GP-410-IS00-O (5m)	GP Series
	LC02-ON	RS-232C (Cable Diagram 1)	RS-232C Digital's GP410-IS00-O (5m)	
		RS-422 (Cable Diagram 2)		
		RS-422 1:n communication *1 (Cable Diagram 3)		

* 1 1:n Communication

The system structure of 1:n communication for Yokogawa PLCs (FA500), or equipment supporting its protocol (n#), and a GP unit (1) used as an upper link protocol is described here.

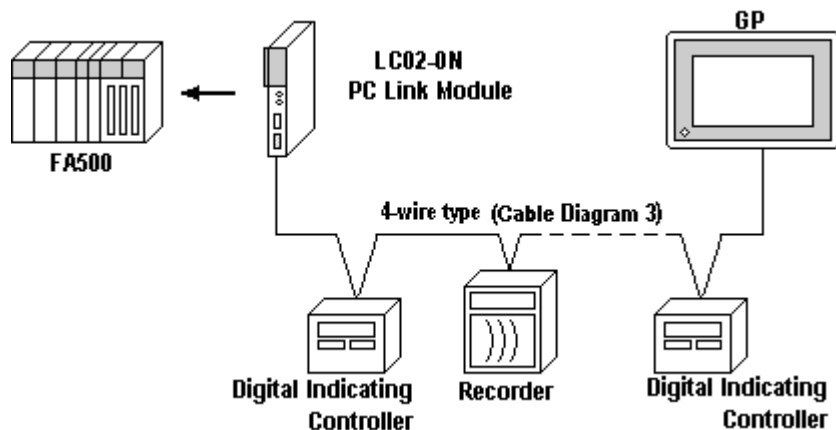

(See next page)

(Continued from previous page)

* FA500 and equipment (Digital Indicating Controller, <UT37/38/2000> and Recorder, <μR-Series>...etc) supporting the same protocol are hereafter referred to as *PA Equipment*.

- Be sure to use only one GP in the system.
- In the Link above, maximum 32 PA Equipment can be connected to one GP.
- When Sequence Control is unnecessary, the system structure is possible without the PLC.
- Using the method above, Unit No. s 1~16 can be setup; a Unit No. of 17 or higher cannot be used.



Wherever RS-422 appears in the table, RS-485 can be used on the PLC.

■ **FACTORY ACE Series/FA-M3** (using Link I/F)

CPU	Link I/F	Cable Diagram	Cables	GP
		← PC Link Module →		
F3SP10-0N	F3LC01-1N	RS-232C (Cable Diagram 4)		GP Series
F3SP20-0N, F3SP21-0N, F3SP25-2N, F3SP28-3N, F3SP30-0N, F3SP35-5N, F3SP38-6N, F3SP53-4H, F3SP58-6H, F3FP36-3N	F3LC11-1N F3LC11-1F	RS-232C (Cable Diagram 4)		
	F3LC11-2N	RS-422 (Cable Diagram 2)		
	F3LC11-2N	RS-422 1:n communication ^{*1} (Cable Diagram 3)		

***1 1:n Communication**

The system structure of 1:n communication for Yokogawa PLCs (FA-M3), or equipment supporting its protocol (n#), and a GP unit (1) used as an upper link protocol is described here.

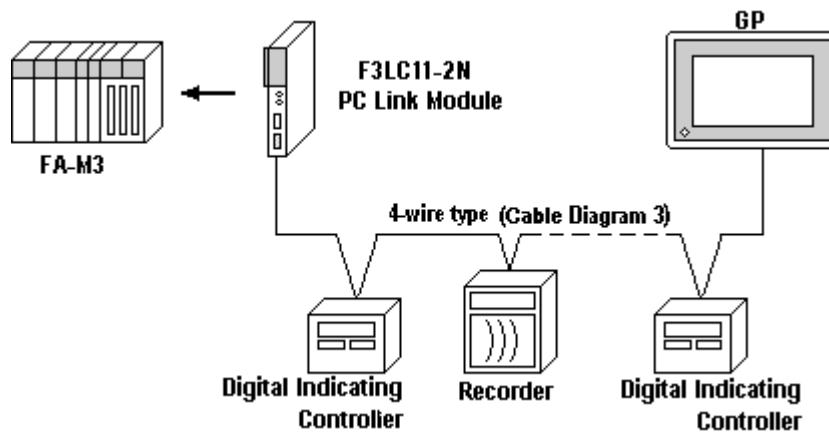

(See next page)



* FA-M3 and equipment (Digital Indicating Controller, <UT37/38/2000> and Recorder, <mR-Series>...etc) supporting the same protocol is referred to as *PA Equipment*, below.

- *Be sure to use only one GP in the system.*
- *In the Link above, maximum 32 PA Equipment can be connected to one GP.*
- *When Sequence Control is unnecessary, the system structure can be created without the PLC.*
- *In the method above, Unit No. of 1~16 can be setup; a Unit No. of 17 or more cannot be used.*

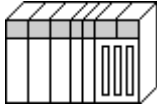

Wherever RS-422 appears in the table, RS-485 can be used on the PLC.

■ **FACTORY ACE Series/FA-M3 (CPU Direct Connection)**

CPU	Cables	GP
		
F3SP21-0N, F3SP25-2N, F3SP28-3N, F3SP35-5N, F3SP38-6N, F3SP53-4H, F3SP58-6H	Yokogawa's cable for programming tool KM11-2N*A	GP Series



Two GP units cannot be connected at the same time using the PC Link I/F.

2.8.2 Cable Diagrams

The cable diagrams illustrated below and the cable diagrams recommended by Yokogawa Electric may differ, however, using these cables for your PLC operations will not cause any problems.



Ground your PLC's FG terminal according to your country's applicable standard. For details, refer to the corresponding PLC manual.



- **Connect the FG line of the Shield cable to either the GP or PLC, depending on your environment. When using a connector hood and grounding the FG line, be sure to use an electrical conductor. The following connection diagrams show examples for connecting a shielded cable to the PLC.**
- **For the RS-232C connection, use a cable length less than 15m.**
- **If a communications cable is used, it must be connected to the SG (signal ground).**
- **For the RS-422 connection, refer to Yokogawa's PLC manual for the cable length.**

Cable Diagram 1 (RS-232C)

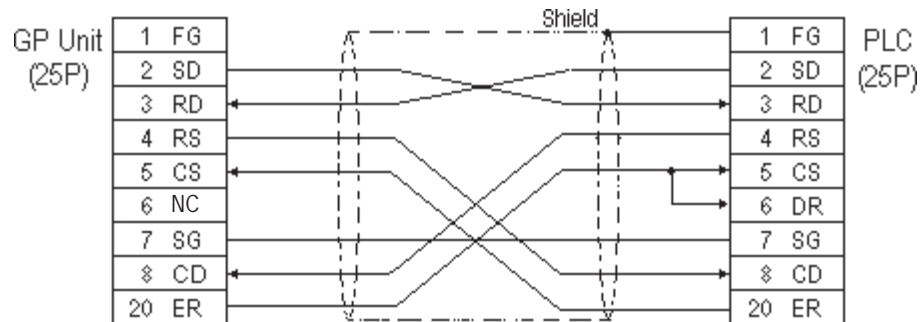

Cable Diagram 2 (RS-422)

- When using Digital's RS-422 connector terminal adapter GP070-CN10-0

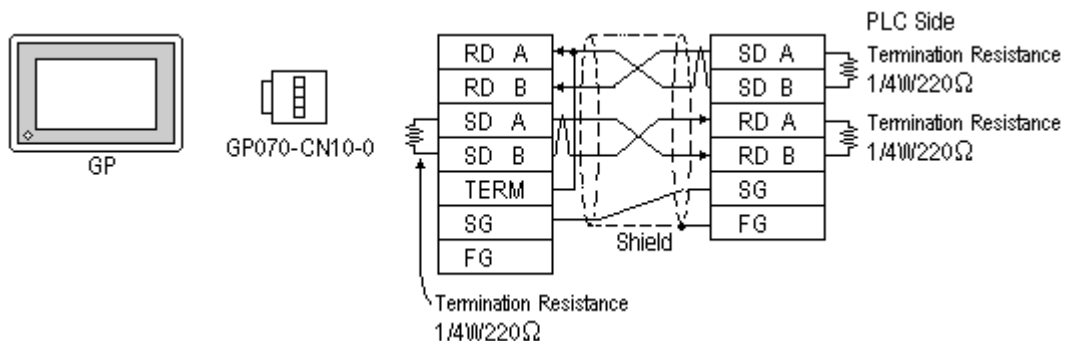

- When using Digital's RS-422 Cable, GP230-IS11-0

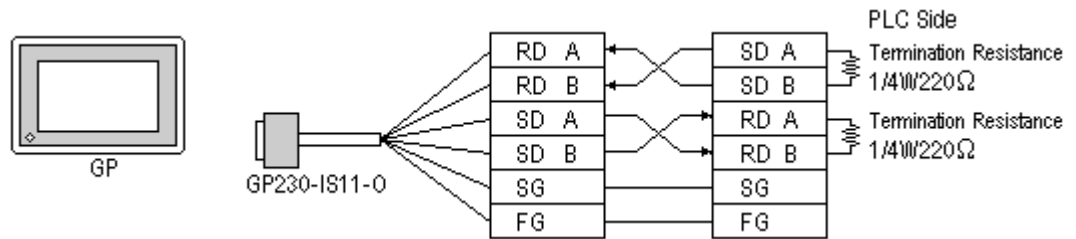

- When making your own cable connections

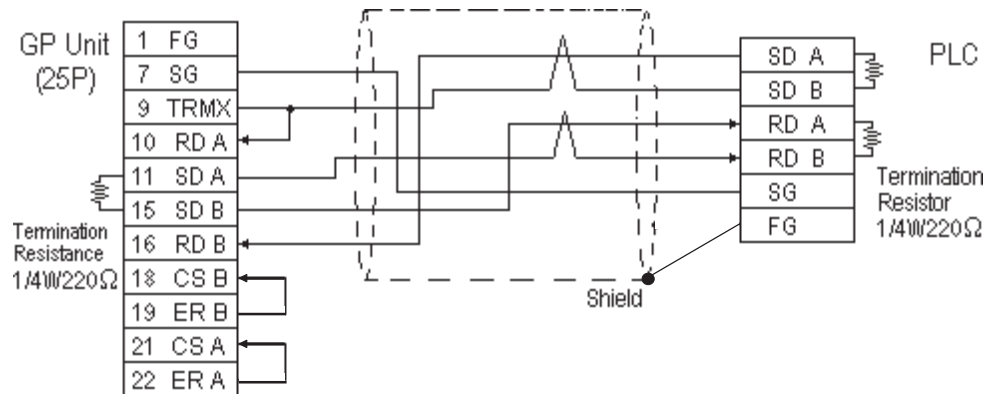

Note:

- When making your own connections, we recommend using Hitachi Densen's CO-SPEV-SB(A)3P*0.5SQ cable.
- When connecting the #9 and #10 pins in the GP Serial I/F, a termination resistance of 100Ω is added between RDA and RDB.

Cable Diagram 3 (RS-422)

The diagrams below are examples of wire connections on both ends of the GP and PLC. Setup the termination resistors on both ends of the equipment, as illustrated.



Important

- **Be careful as the reading of the A signal and B signal is opposite on the GP and the LC02-0N (PLC).**
- **Make the PC Link I/F Station Number from 2 to 32.**
- **Setup the PA unit connected to the GP using different Unit Numbers. An error will develop if multiple PA units are setup using the same Unit Number. When an error occurs, the error message "Receiving Data Error occurs (02:FD:**)" (** indicates the unit No.) will appear.**
- **Setup the GP (1) and PA units (n#) with the same Communication Settings.**

- When using Digital's RS-422 connector terminal adapter GP070-CN10-0

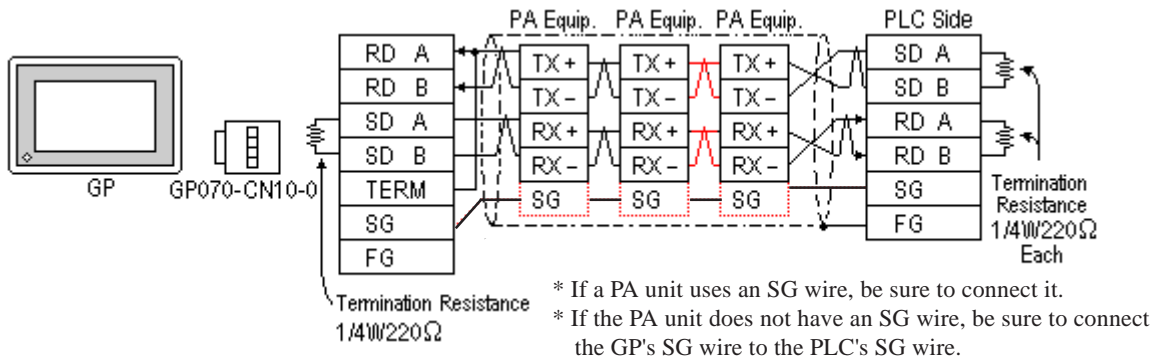

- When using Digital's RS-422 Cable, GP230-IS11-0

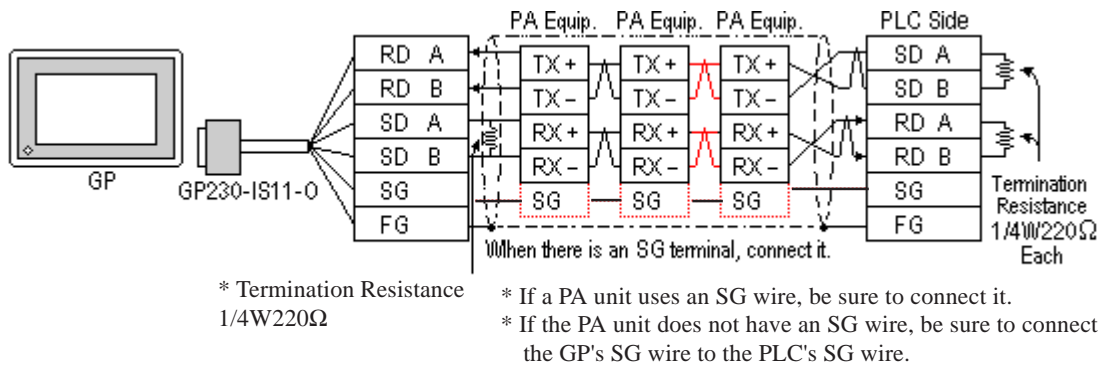

- When making your own cable connections

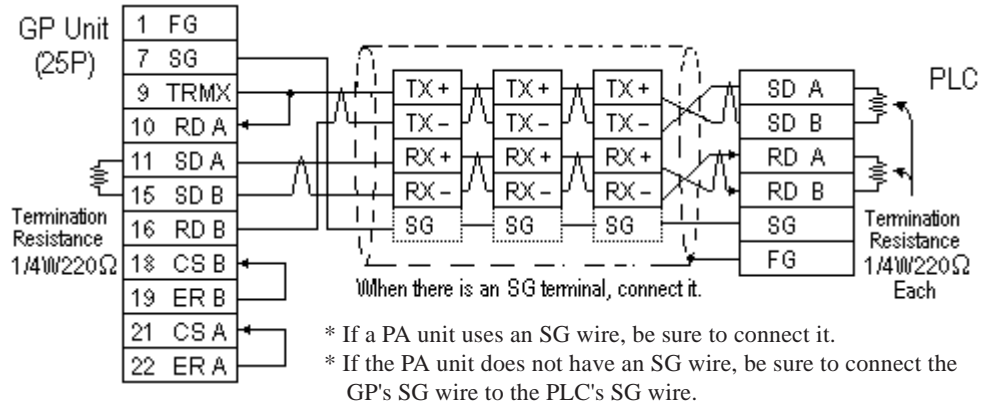





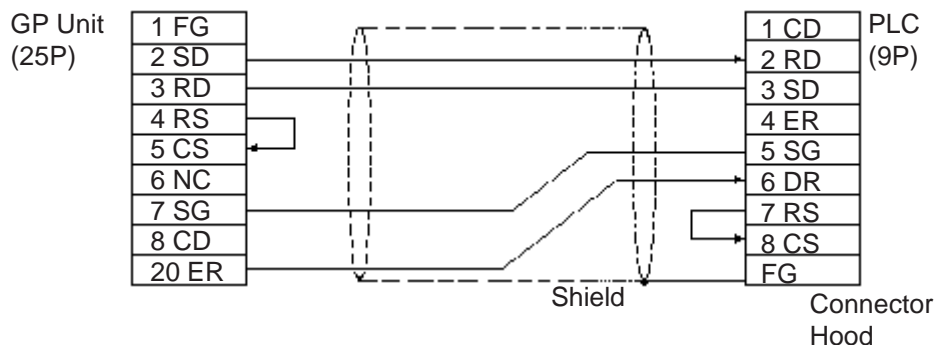





When connecting the #9 and #10 pins in the GP Serial I/F, a termination resistance of 100Ω is added between RDA and RDB.

Cable Diagram 4 (RS-232C)



■ FA500 (1:n communication)

 Setup System Area here.

Device	Bit Address	Word Address	Particulars
Input Relay	X00201 ~ X61164	X00201 ~ X61149	 *1*2
Output Relay	Y00201 ~ Y61164	Y00201 ~ Y61149	 *1*2
Internal Relay	I0001 ~ I2048	I0001 ~ I2033	 *2
Joint Relay	E0001 ~ E2048	E0001 ~ E2033	 *2
Special Relay	M001 ~ M512	M001 ~ M497	 *2*3
Link Relay	L0001 ~ L1024	L0001 ~ L1009	 *2*3
Timer (contact)	T001 ~ T256	---	*2
Counter (contact)	C001 ~ C256	---	*2
Timer (current value)	---	TP001 ~ TP256	*2
Timer (setup value)	---	TS001 ~ TS256	*2
Counter (current value)	---	CP001 ~ CP256	*2
Counter (setup value)	---	CS001 ~ CS256	*2
Data Register	---	D0001 ~ D2047	 *2
Common Register	---	B0001 ~ B2047	 *2
Special Register	---	Z001 ~ Z128	 *2*3
Link Register	---	W0001 ~ W1024	 *2*3

L/H

* 1 When setting Word Address, set the value of the terminal number, 01~49, of the last two digits for the Input Relay and Output Relay to a multiple of 16+1.

E.g. For X00201

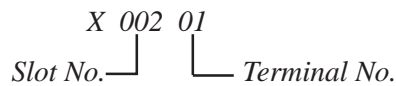

* 2 Write the CPU Number (1~4) in front of the device name.

E.g. For Internal Relay I0001, CPU #3:

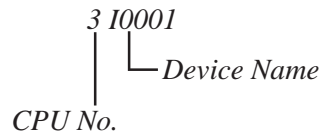

* 3 Cannot perform data write.



When setting tags up in GP-PRO/PBIII for Windows, the PLC Station number can be specified during address Input. If a station number is not indicated, it automatically uses the previously entered station number. (The initial default value is 1.)

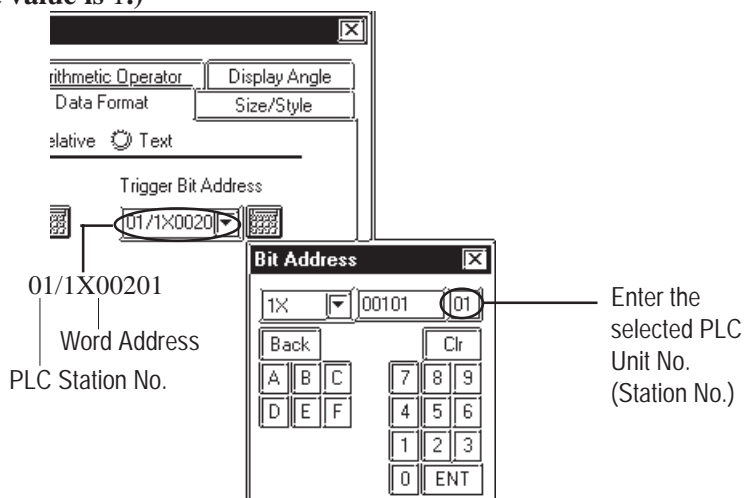

■ FA-M3 (1:1 Communication)

 Setup System Area here.

Device	Bit Address	Word Address	Particulars
Input Relay	X00201 ~ X71664	X00201 ~ X71649	÷16+ *1,2
Output Relay	Y00201 ~ Y71664	Y00201 ~ Y71649	÷16+ *1
Internal Relay	I00001 ~ I32768	I00001 ~ I32753	÷16+
Joint Relay	E0001 ~ E4096	E0001 ~ E4081	÷16+
Special Relay	M0001 ~ M9984	M0001 ~ M9969	÷16+
Link Relay	L00001 ~ L78194	L00001 ~ L78177	÷16+
Timer (contact)	T0001 ~ T3072	---	*2
Counter (contact)	C0001 ~ C3072	---	*2
Timer (current value)	---	TP0001 ~ TP3072	
Timer (setup value)	---	TS0001 ~ TS3072	*2
Counter (current value)	---	CP0001 ~ CP3072	
Counter (setup value)	---	CS0001 ~ CS3072	*2
Data Register	---	D0001 ~ D32768	Bit 5
File Register	---	B00001 ~ B065536	Bit 5 *3,4
		B065537 ~ B131072	
		B131073 ~ B196608	
		B196609 ~ B262144	
Joint Register	---	R0001 ~ R4096	Bit 5
Special Register	---	Z001 ~ Z1024	Bit 5
Link Register	---	W00001 ~ W74096	Bit 5 *5

L/H

(See next page)

*1 The value of the terminal number (bit), 01~49, of the last two digits for the Input Relay and

Output Relay can only be a multiple of 16 +1.

E.g. For X00201

X 002 01
 Slot No. └──┬──┘ Terminal No.

*2 Cannot perform data write.

*3 File registers are each 65,535 words on your GP application.

You cannot extend over more than a single data "block" when performing the following features.

Be sure to set these features' settings so they are within a single data block.

1) "a-tag" settings

2) Performing Block read/write from Pro-Server

3) Designating the "Convert from" and "Convert to" address for the "Address Conversion" features

*4 When using a PC Link module, only Link Register up to B99999 can be used.

*5 A total of up to 4,096 link registers can be used.



• Write the CPU Number (1~4) in front of the device name.

E.g. For Internal Relay I0001, CPU #3:

3 I0001
 CPU No. └──┬──┘ Device Name

• The range of device that can be used will vary depending on the type of PLC.

For detailed information refer to the Yokogawa's Sequence CPU manual.



Note: When running tag setup in GP-PRO/PBIII for Windows, the PLC Station number can be specified at address Input. If a station number is not indicated, it automatically uses the previously entered station number. (The initial default value is 1.)

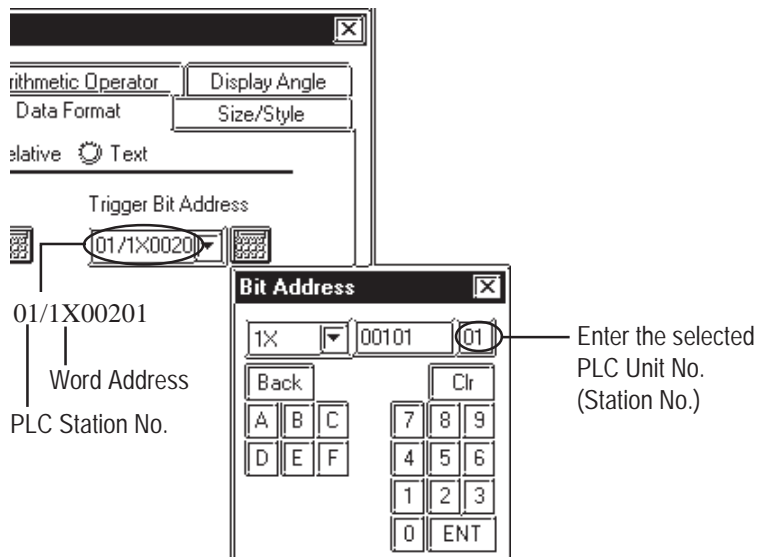

2.8.4 Environment Setup

The following lists Digital's recommended PLC and GP communication settings.

■ FACTORY ACE Series (using Link I/F RS-232C connection)

GP Setup		PC Link Module Setup	
Baud Rate	19200 bps	Baud Rate ^{*1}	19200 bps
Data Length	8 bits	Data Length	8 bits
Stop Bit	1 bit	Stop Bit	1 bit
Parity Bit	None	Parity Bit	None
Data Flow Control	ER Control	---	
Communication Format	RS-232C	---	
---		Check Sum	No
---		Specify End Character	Yes
---		Protect Function	No
---		Data Format Setup Switch	8 OFF
Unit No.	1	Station Number ^{*2}	1

**1 The PC Link I/F F3LC11-1F can be communicated by 115.2kbps.*

**2 The PC Link I/F F3LC01-1N does not have this setting.*

■ FACTORY ACE Series (using Link I/F RS-422 connection)

GP Setup		PC Link Module/PA Equipment Setup	
Baud Rate (1:1 comm)	19200 bps	Baud Rate (1:1 comm)	19200 bps
Baud Rate (1:n comm)	9600 bps	Baud Rate (1:n comm)	9600 bps
Data Length	8 bits	Data Length	8 bits
Stop Bit	1 bit	Stop Bit	1 bit
Parity Bit	None	Parity Bit	None
Data Flow Control	ER Control	---	
Communication Format	4-wire type	---	
---		Check Sum	No
---		Specify End Character	Yes
---		Protect Function	No
---		Data Format Setup Switch	8 OFF
Unit No. (1:1 comm)	FA-500: 2 FA-M3: 1	Station No. (1:1 comm)	FA-500: 2 FA-M3: 1
Unit No. (1:n comm)	Match with PC Link Module station No.	Station No. (1:n comm)	Set up so that all PA Equip., PC Link module No.s are different

■ **FACTORY ACE Series** (FA-M3 CPU Direct Connection)

GP Setup		CPU Communication Port Setup	
Baud Rate	19200 bps	Baud Rate	19200 bps ^{*1}
Data Length	8 bits	---	
Stop Bit	1 bit	---	
Parity Bit	Even	Parity Bit	Even
Data Flow Control	ER Control	---	
Communication Format	RS-232C	---	
---		PC Link Function	Use
---		Check Sum	No
---		Specify End Character	Yes
---		Protect Function	No
Unit No.	1	---	

**1 For F3SP28-3N, F3SP38-6N, F3SP53-4H, and F3SP58-6H, a baud rate of 115200 bps is also available.*



2.9 Toyota Machine Works

2.9.1 System Structure

The following describes the system structure for connecting the GP to Toyota Machine Works PLCs.

Reference The Cable Diagram mentioned in the following table is listed in the section titled "2.9.2 Cable Diagrams."

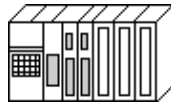
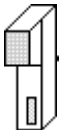
■ TOYOPUC-PC2 Series (using Link I/F)

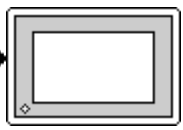
CPU	Link I/F	Cable Diagram	GP
	Computer Link Module/ Link I/F 		
PC2, L2	TPU-2652 (Computer Link Module)	RS-422 (Cable Diagram 1)	GP series
PC2J	THU-2755 (PC/CMP Link Unit)		
	THU-2755	RS-422 *1 1:n communication (Cable Diagram 2)	

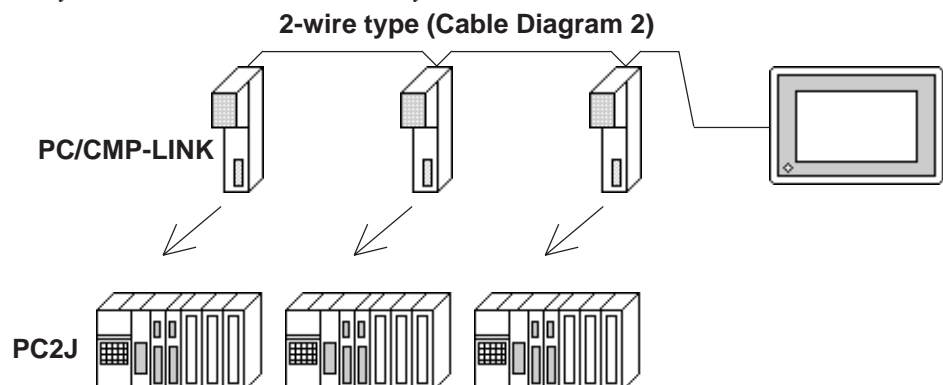

*1 The following system configuration shows how to communicate between one GP and "n" PC2J PLCs, using a host link protocol.

- Only one GP can be used in this system.

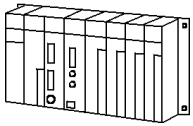

- Up to 16 PC2J units can be connected to the single GP.

■ TOYOPUC-PC3J

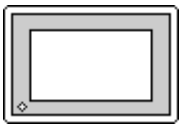
CPU	Link I/F	Cable Diagram	GP
			
PC3J	Link I/F for CPU unit	RS-422 (4 wires) (Cable Diagram 3)	GP Series
		RS-422 (2 wires) (Cable Diagram 4)	
		RS-422 (4 wires) (1:n) (Cable Diagram 5)	
		RS-422 (2 wires) (1:n) (Cable Diagram 6)	
	PC/CMP-Link (THU-2755) *1	RS-422 (2 wires) (Cable Diagram 7)	
		RS-422 (2 wires) (1:n) (Cable Diagram 8)	

*1 When using PC3J commands to operate the PC/CMP-LINK(THU-2775), a Ver.5.00 or higher link unit is required. This unit, however, will not have the settings for the PC2J or PC3J switches (SW). If a PC3J command is sent to a version5.00 or lower link unit, an error code will appear on the bottom left corner on the GP screen.



- A maximum of 16 PLCs can be connected.
- For the connection cable, the Chugoku Densen Kogyo's double shield twist cable, 0-VCTF-SS 2C*0.75mm² is recommended.
- The maximum cable length is 600 meters.

2.9.2 Cable Diagrams

The cable diagrams illustrated below and the cable diagrams recommended by Toyota Machine Works, Ltd. may differ; however, using these cables for your PLC operations will not cause any problems.



Ground your PLC's FG terminal according to your country's applicable standard. For details, refer to the corresponding PLC manual.



- **Connect the FG line of the Shield cable to either the GP or PLC, depending on your environment.**
- **If a communications cable is used, it must be connected to the SG (signal ground).**

Cable Diagram 1 (RS-422)

- When using Digital's RS-422 connector terminal adapter GP070-CN10-0

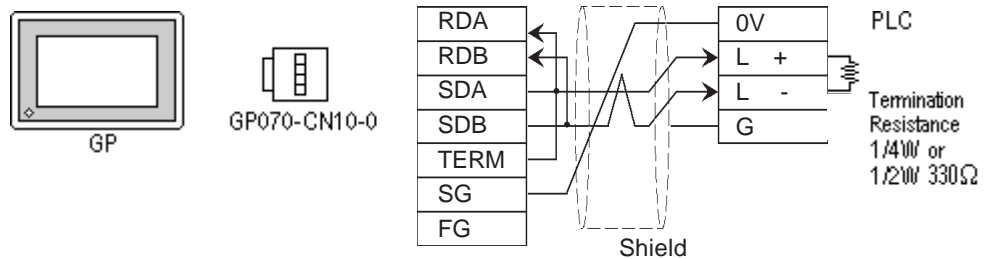

Connect terminals SD A and SD B to terminal L+, and SD B and RD B to terminal L-.

- When using Digital's RS-422 Cable, GP230-IS11-0

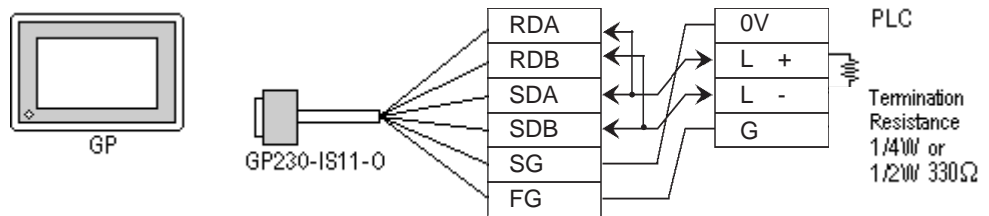

Connect terminals SDA and SDB to terminal L+, and SDB and RDB to terminal L-.

- When making your own cable connections

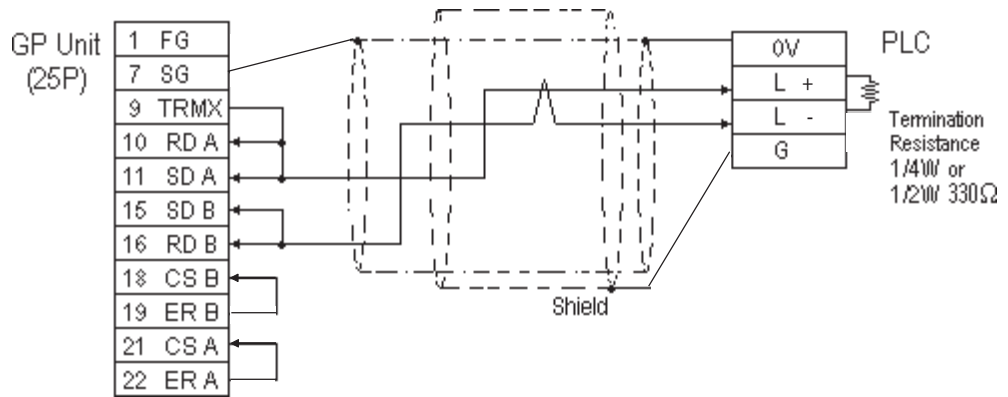

- When making your own connections, we recommend using Chugoku Densen Kogi's O-VCTF-SS2C*0.75mm² (2 overlapping *Shield Twist Pair*) cable.
- When connecting the #9 and #10 pins in the GP Serial I/F, a termination resistance of 100Ω is added between RDA and RDB.

Cable Diagram 2 (RS-422)

- When using Digital's RS-422 connector terminal adapter GP070-CN10-0

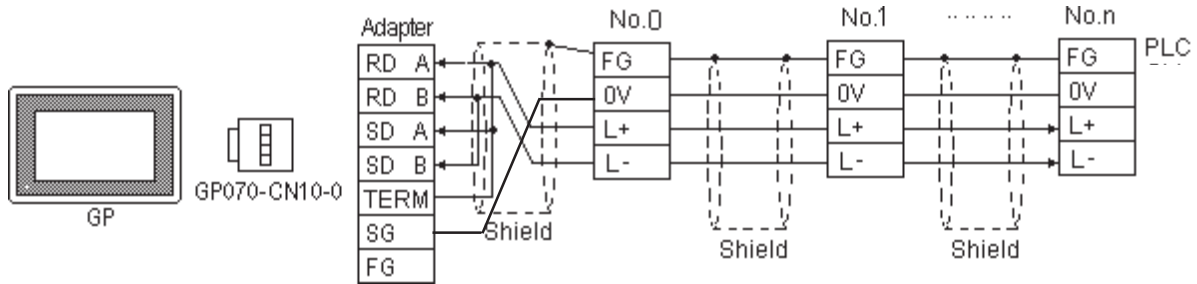

- When using Digital's RS-422 Cable, GP230-IS11-0

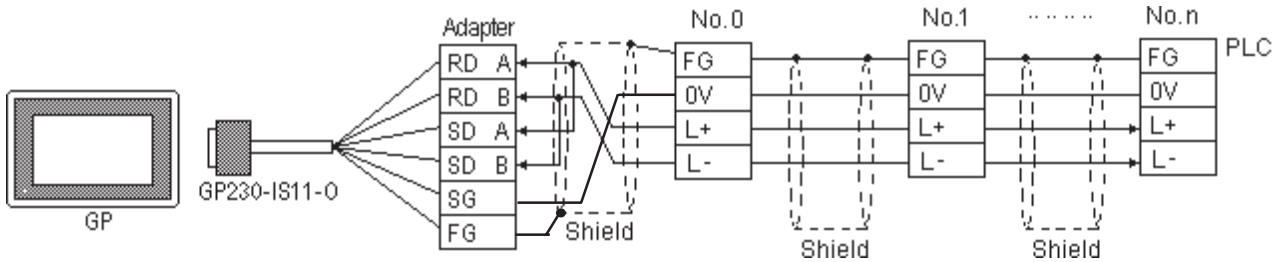

- When making your own cable connections

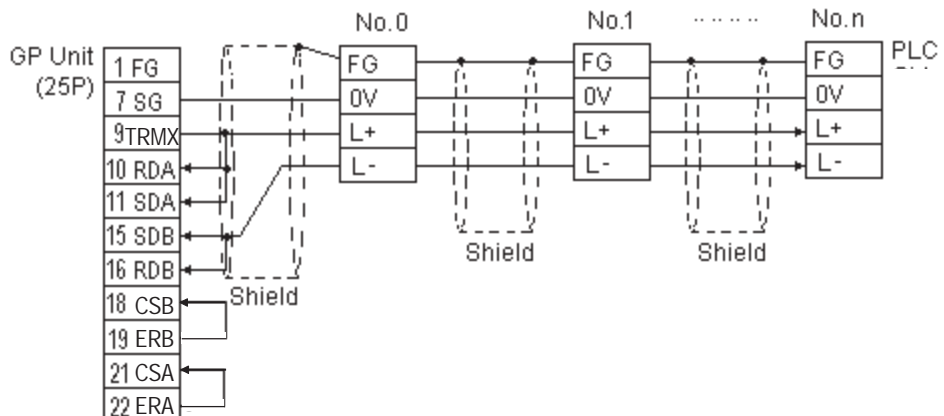

Cable Diagram 3 RS-422 4-wire type

- When using Digital's RS-422 connector terminal adapter GP070-CN10-0

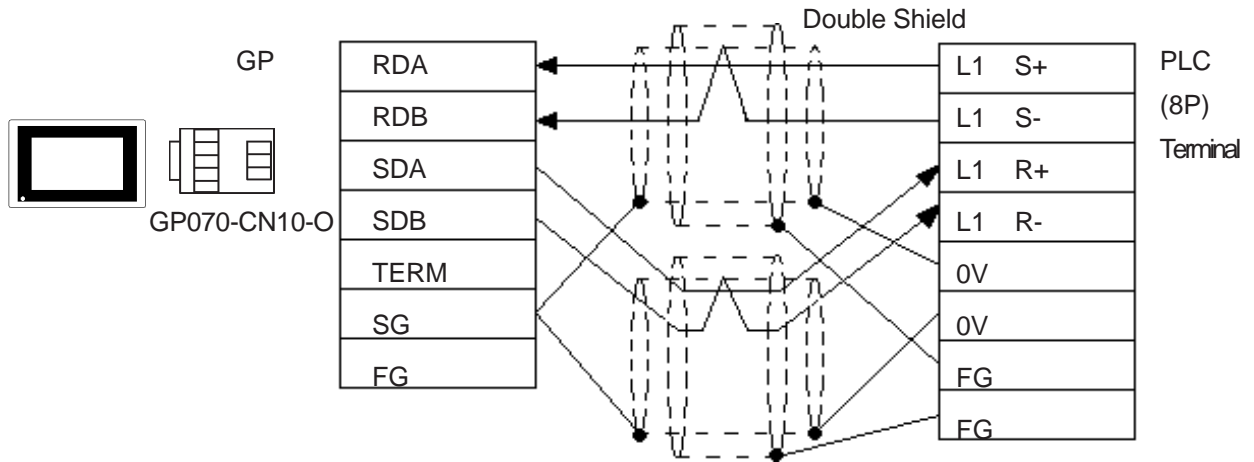

- When using Digital's RS-422 cable, GP230-IS12-0



Note: In areas with excessive noise, use a double shielded cable.

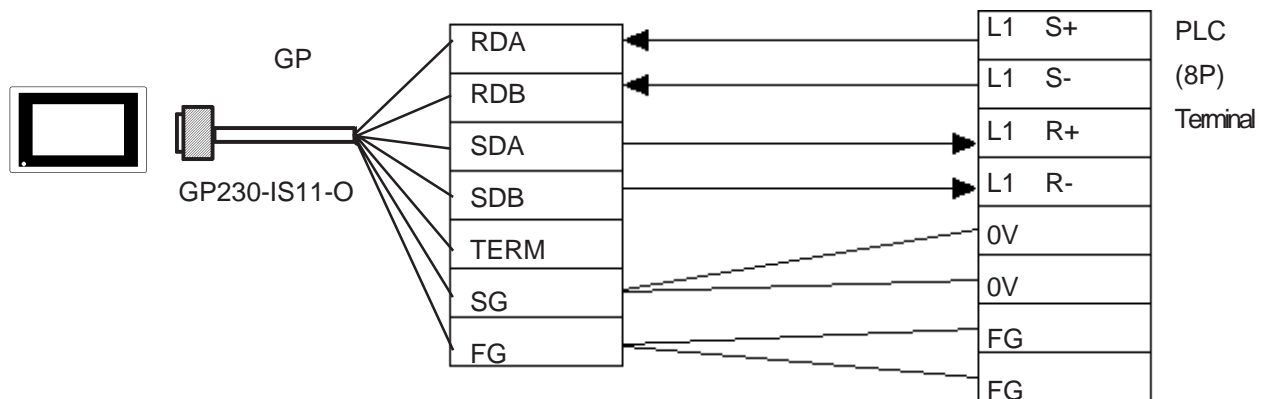

- When making your own cable

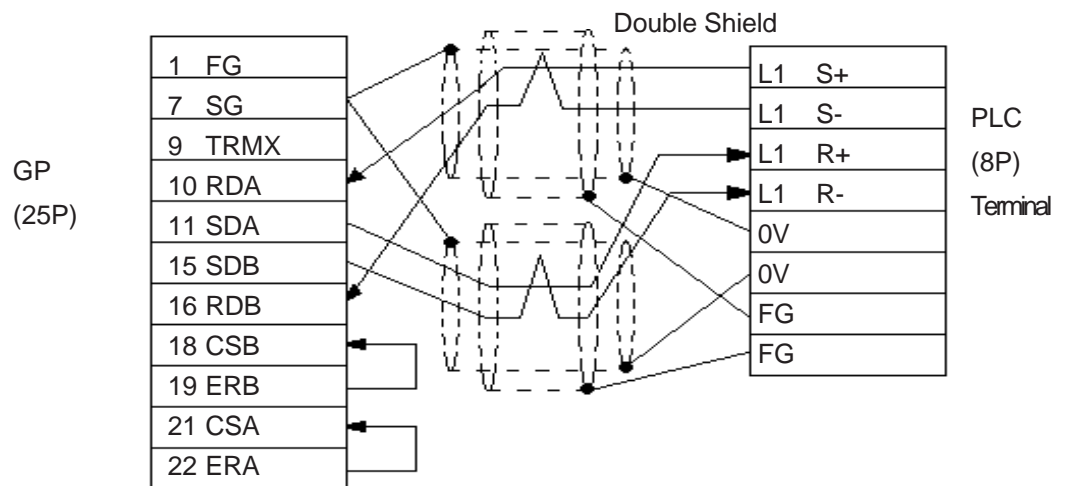

Cable Diagram 4 (1:1) RS-422 2-wire type, using I/F unit for CPU

- When using Digital's RS-422 connector terminal adapter GP070-CN10-0

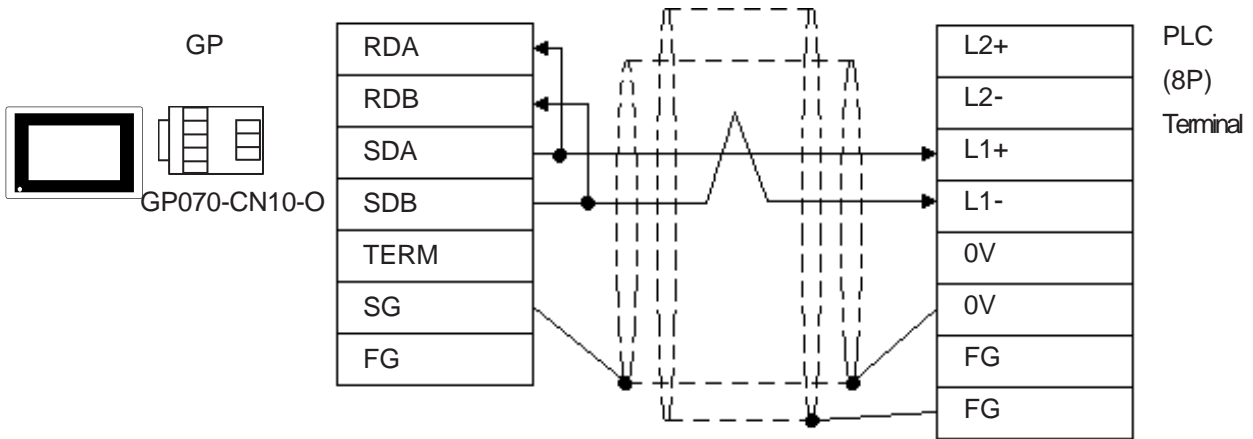

- When using Digital's RS-422 cable, GP230-IS12-0

Note: In areas with excessive noise, use a double shielded cable.

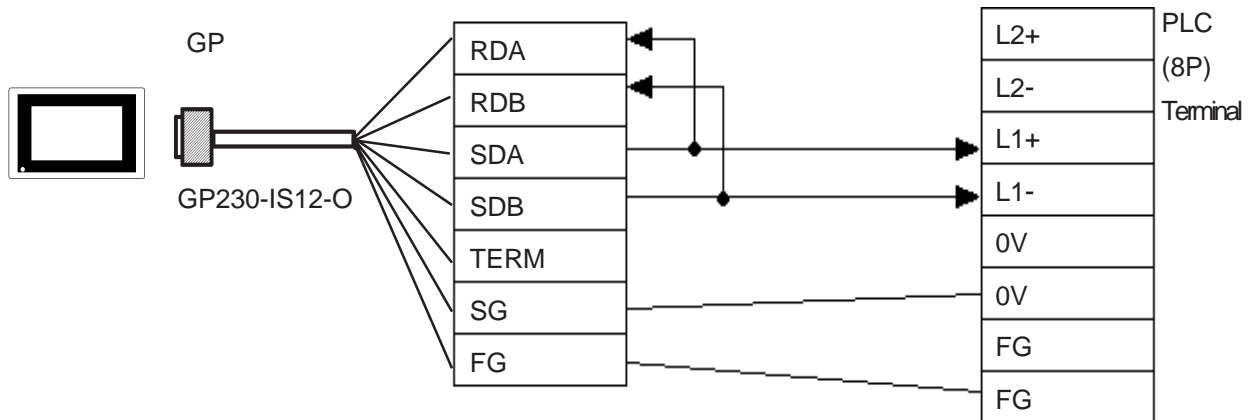

- When making your own cable

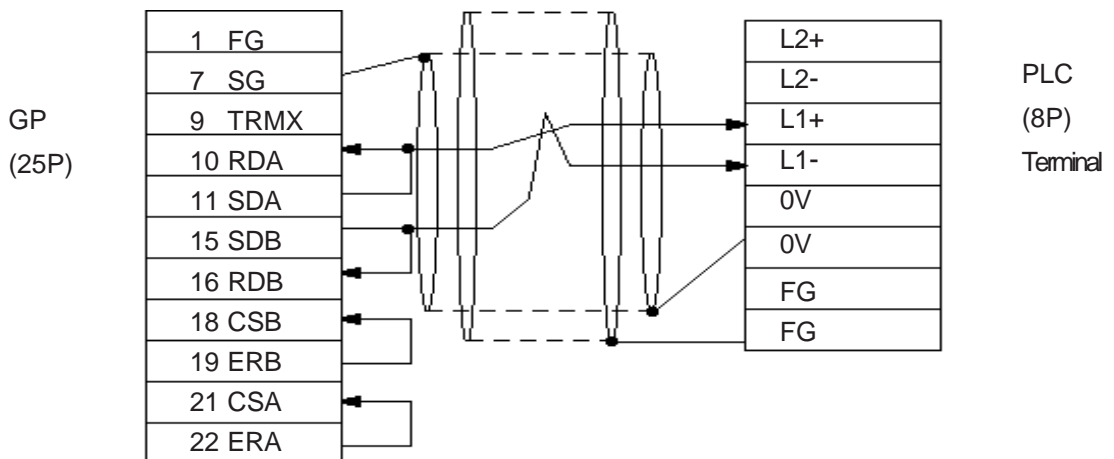

Cable Diagram 5 (1:n) RS-422 4-wire type

- When using Digital's RS-422 connector terminal adapter GP070-CN10-0

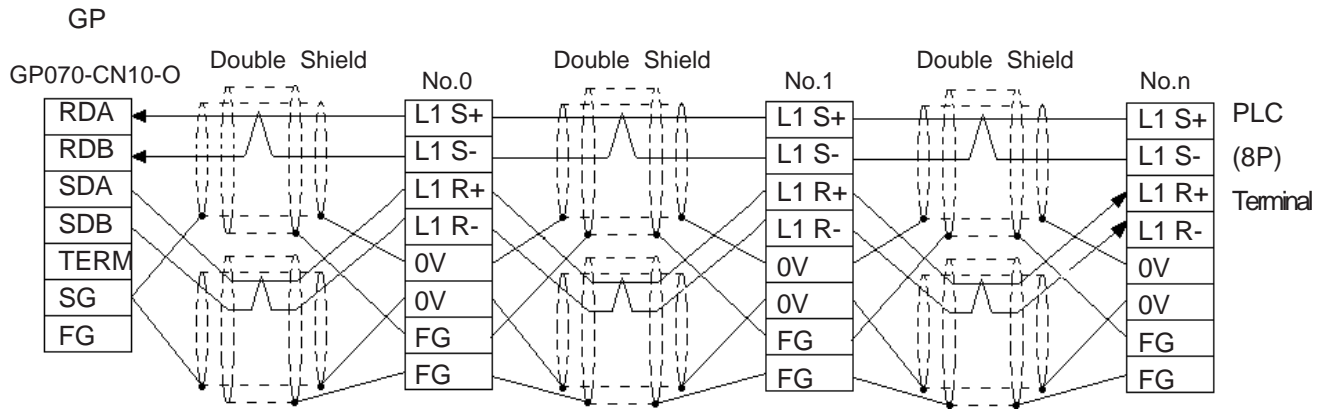

- When using Digital's RS-422 cable, GP230-IS12-0



In areas with excessive noise, use a double shielded cable.

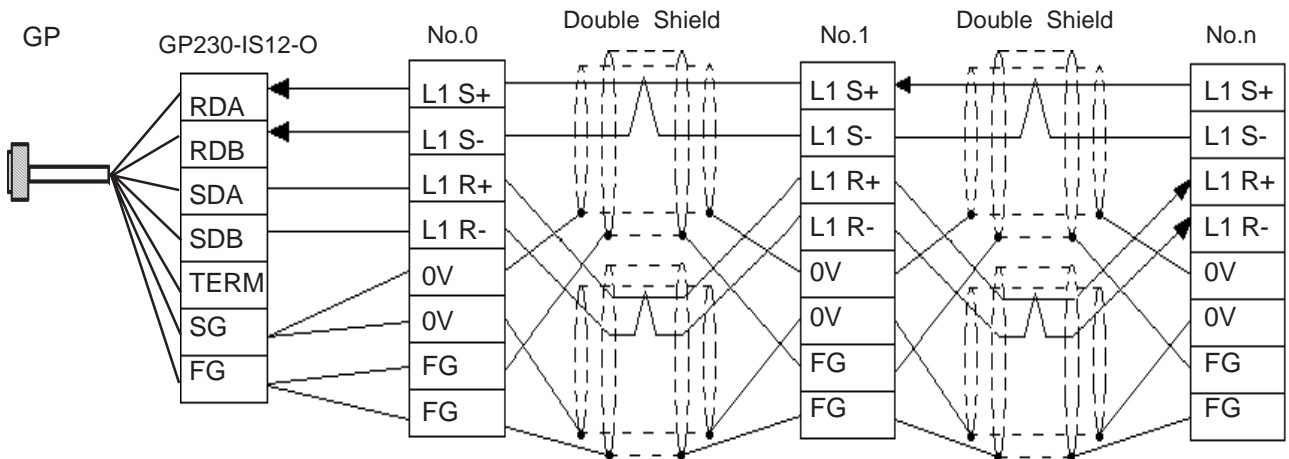

- When making your own cable

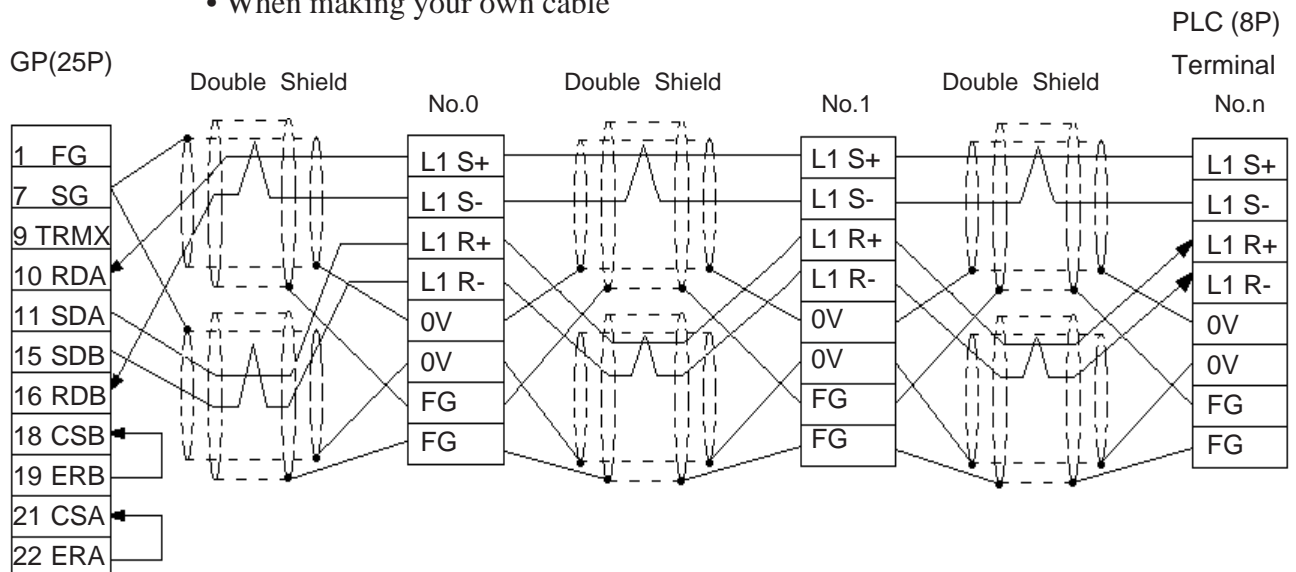

Cable Diagram 6 (1:n) RS-422 2-wire type, using I/F unit for CPU

- When using Digital's RS-422 connector terminal adapter GP070-CN10-0

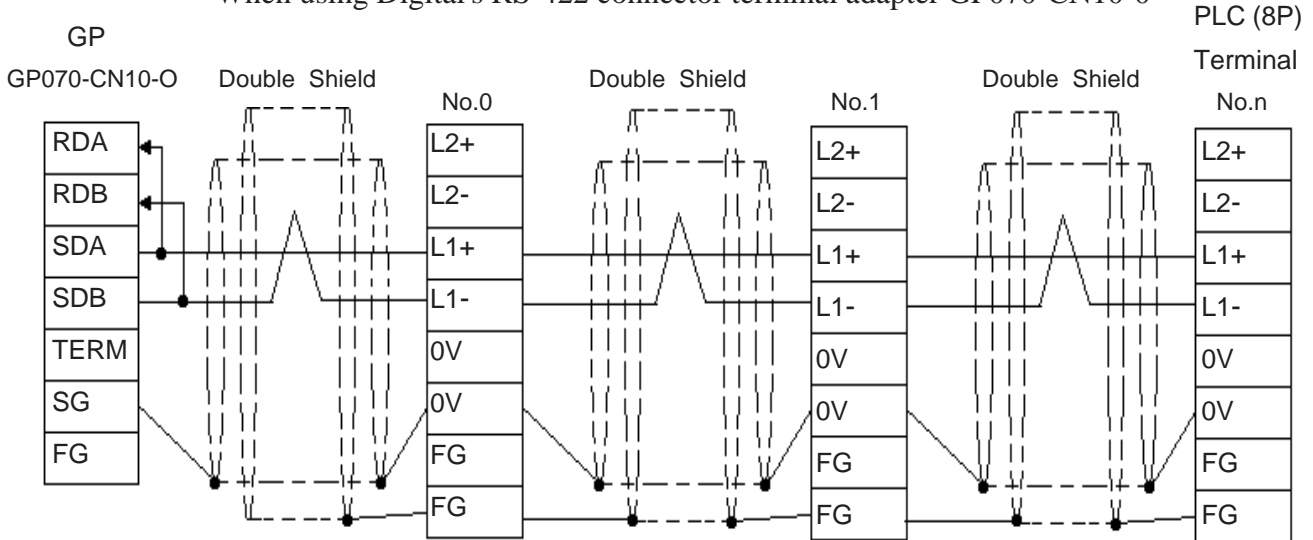

- When using Digital's RS-422 cable, GP230-IS12-0



Note: In areas with excessive noise, use a double shielded cable.

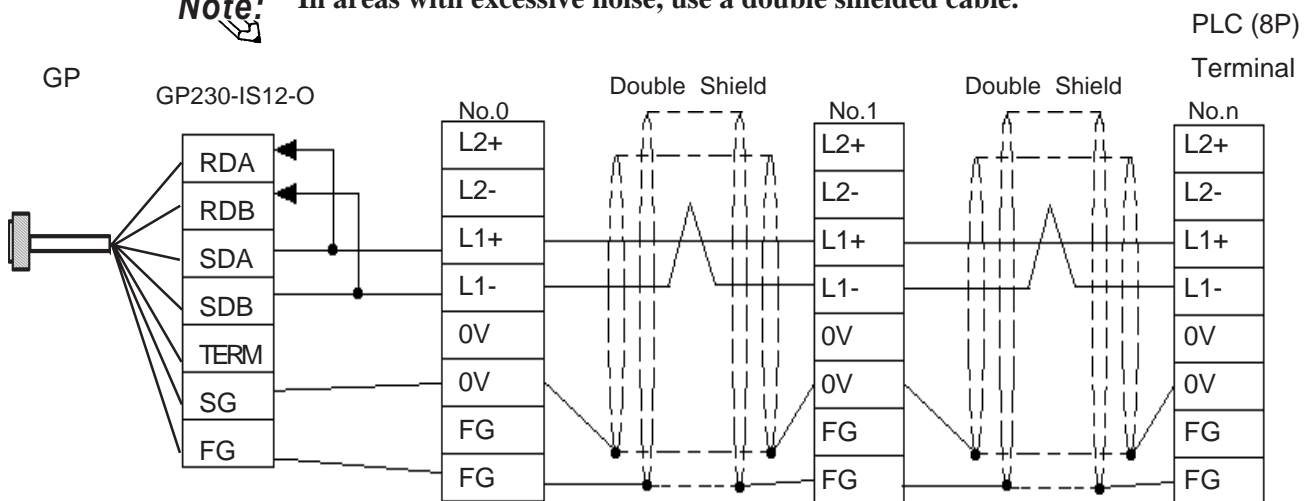

- When making your own cable

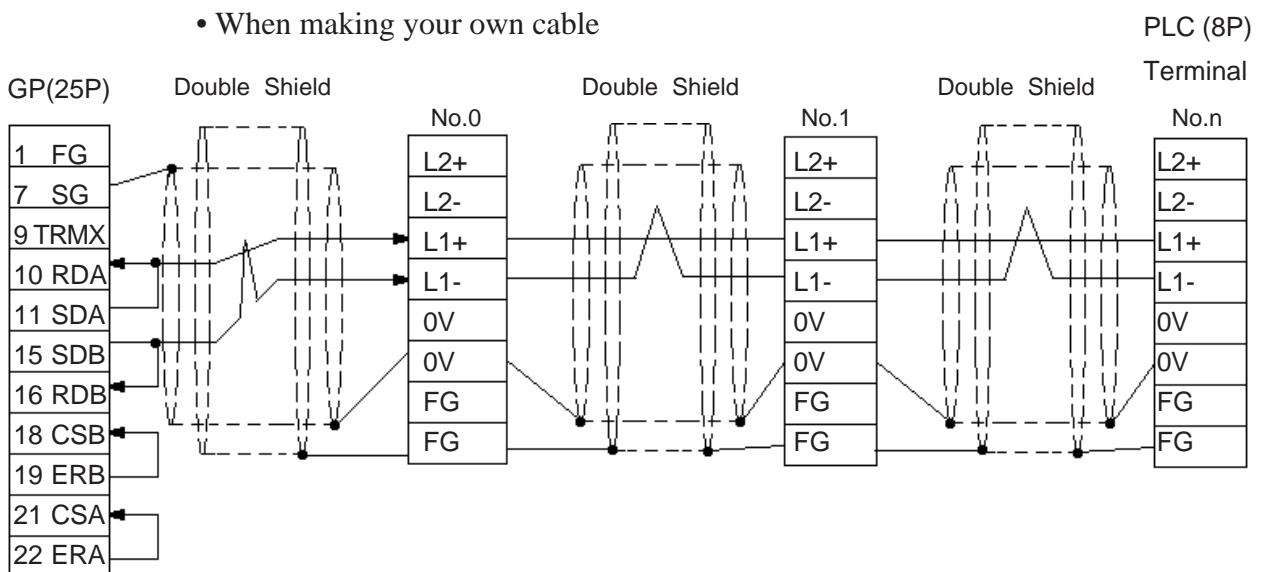

Cable Diagram 7 (1:1) <PC/CMP-Link> RS-422 2-wire type

- When using Digital's RS-422 connector terminal adapter GP070-CN10-0

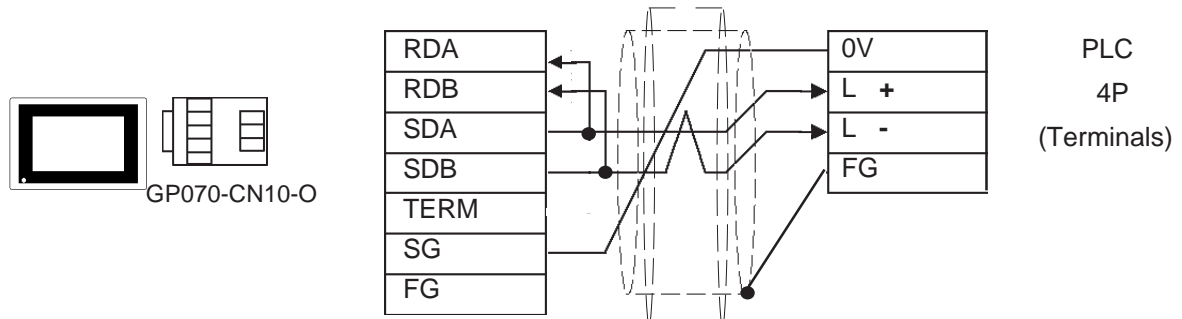

- When using Digital's RS-422 cable, GP230-IS11-0



In areas with excessive noise, use a double shielded cable.

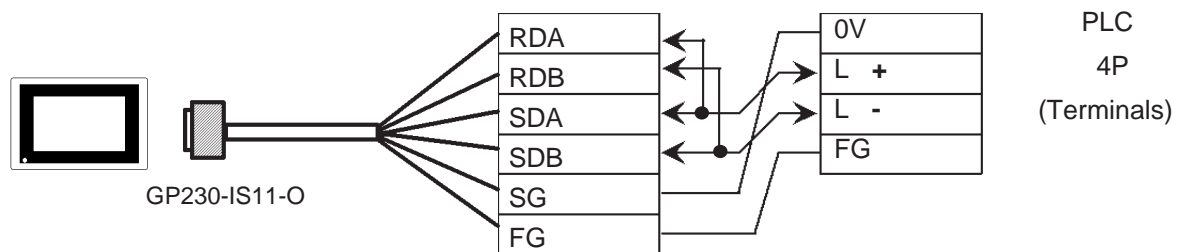

- When making your own cable

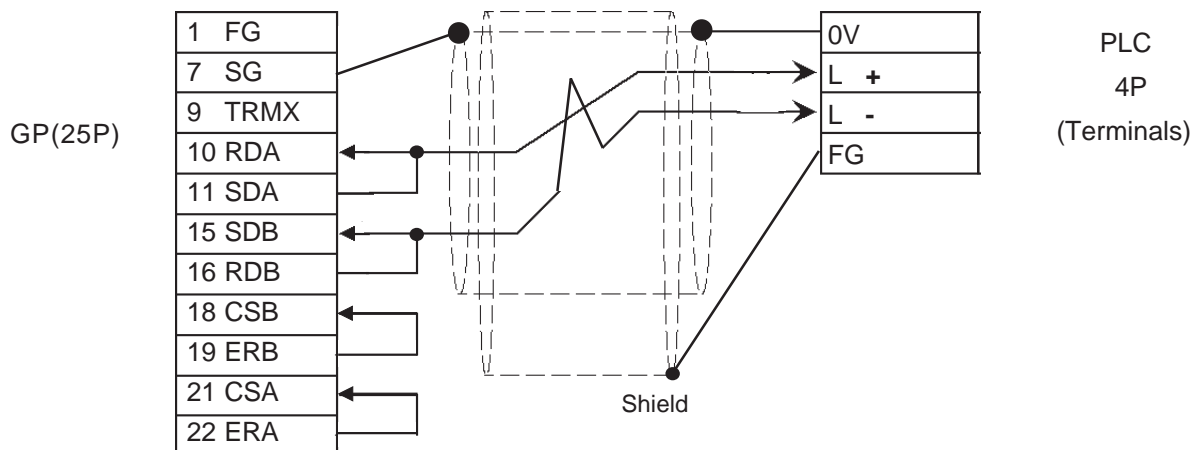

Cable Diagram 8 (1:n) <PC/CMP-Link> RS-422 2-wire type

- When using Digital's RS-422 connector terminal adapter GP070-CN10-0

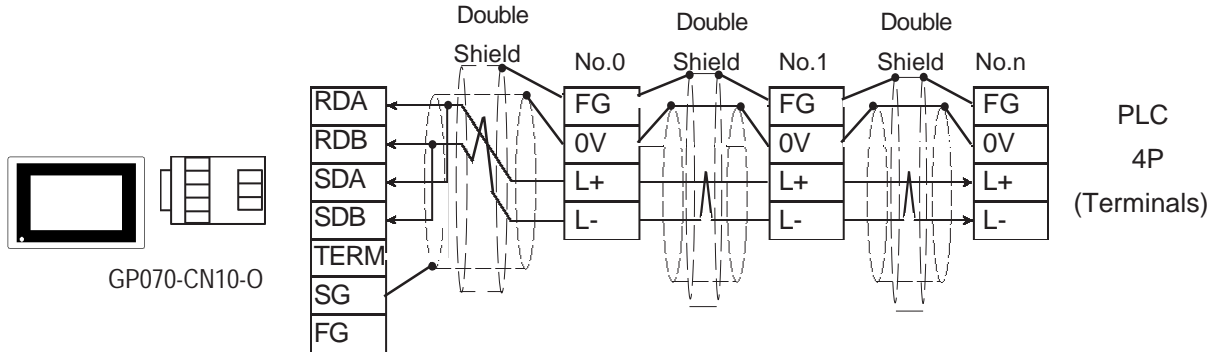

- When using Digital's RS-422 cable, GP230-IS12-0

Note: In areas with excessive noise, use a double shielded cable.

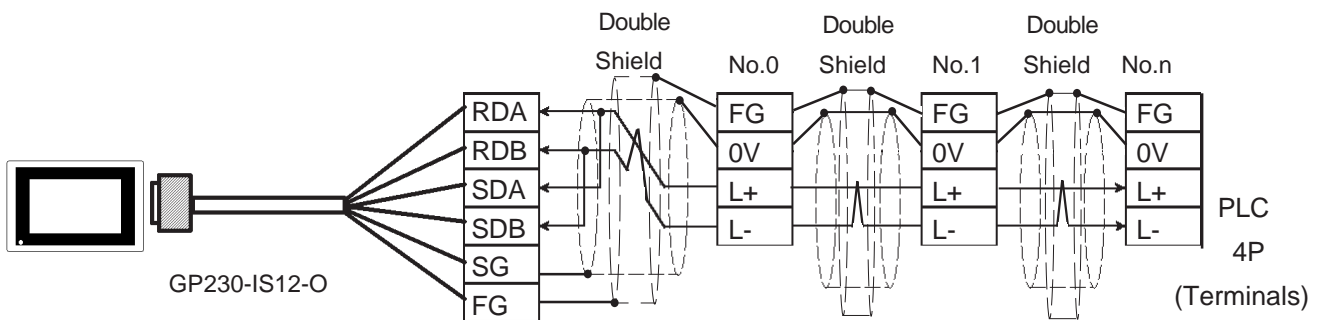

- When making your own cable

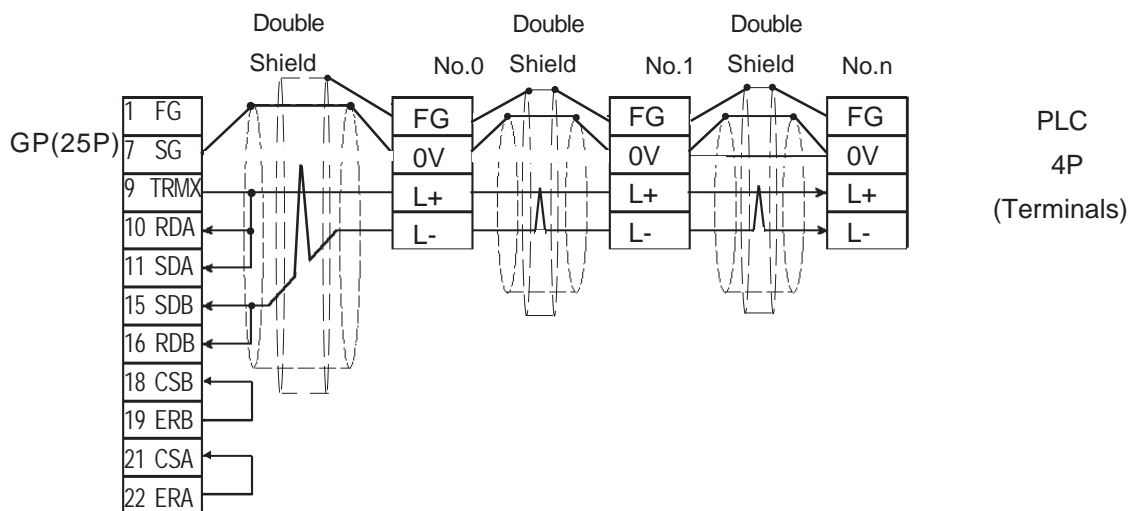





2.9.3 Supported Devices

The following describes the range of devices supported by the GP.

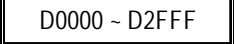



■ **TOYOPUC-PC2 Series**

 Setup System Area here.

Device	Bit Address	Word Address	Particulars	
Input Relay	X000 ~ X7FF	X0000 ~ X007F	L/H	
Output Relay	Y000 ~ Y7FF	Y0000 ~ Y007F		
Internal Relay	M000 ~ M7FF	M0000 ~ M007F		
Keep Relay	K000 ~ K2FF	K0000 ~ K002F		
Link Relay	L000 ~ L7FF	L0000 ~ L007F		
Special Relay	V000 ~V0FF	V000~V00F		
Edge Detection	P000 ~ P1FF	---		
Timer (contact)	T000 ~ T1FF	---		
Counter (contact)	C000 ~ C1FF	---		
Current Value Register	---	N0000 ~ N01FF		
Data Register	---	 D0000 ~ D2FFF		
Link Register	---	R0000 ~ R07FF		
File Register	---	B0000~B1FFF		
Special Register	---	S0000 ~ S03FF		

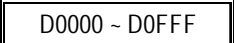
■ **TOYOPUC-PC2 Series (1:n Connection)**

 Setup System Area here.

Device	Bit Address	Word Address	Particulars	
Input Relay	X0000 ~ X07FF	X0000 ~ X007F	L/H	
Output Relay	Y0000 ~ Y07FF	Y0000 ~ Y007F		
Internal Relay	M0000 ~ M07FF	M0000 ~ M007F		
Keep Relay	K0000 ~ K02FF	K0000 ~ K002F		
Link Relay	L0000 ~ L07FF	L0000~L007F		
Special Relay	V0000 ~V00FF	V0000~V000F		
Edge Detection	P0000 ~ P01FF	---		
Timer (contact)	T0000 ~ T01FF	---		
Counter (contact)	C0000 ~ C01FF	---		
Current Value Register	---	N0000 ~ N01FF		
Data Register	---	 D0000 ~ D0FFF		
Link Register	---	R0000 ~ R07FF		
File Register	---	B0000 ~ B0FFF		
Special Register	---	S0000 ~ S03FF		

■ TOYOPUC-PC3J (1:1 connection)

In this list, "Exp." means "Expansion".

Setup system area here.

Device	Bit Address	Word Address	Comments
Input	1X0000 ~ 1X03FF	1X0000 ~ 1X003F	L/H
	2X0000 ~ 2X03FF	2X0000 ~ 2X003F	
	3X0000 ~ 3X03FF	3X0000 ~ 3X003F	
Output	1Y0000 ~ 1Y03FF	1Y0000 ~ 1Y003F	
	2Y0000 ~ 2Y03FF	2Y0000 ~ 2Y003F	
	3Y0000 ~ 3Y03FF	3Y0000 ~ 3Y003F	
Internal Relay	1M0000 ~ 1M07FF	1M0000 ~ 1M007F	
	2M0000 ~ 2M07FF	2M0000 ~ 2M007F	
	3M0000 ~ 3M07FF	3M0000 ~ 3M007F	
Keep Relay	1K0000 ~ 1K02FF	1K0000 ~ 1K002F	
	2K0000 ~ 2K02FF	2K0000 ~ 2K002F	
	3K0000 ~ 3K02FF	3K0000 ~ 3K002F	
Link Relay	1L0000 ~ 1L07FF	1L0000 ~ 1L007F	
	2L0000 ~ 2L07FF	2L0000 ~ 2L007F	
	3L0000 ~ 3L07FF	3L0000 ~ 3L007F	
Special Relay	1V0000 ~ 1V00FF	1V0000 ~ 1V000F	
	2V0000 ~ 2V00FF	2V0000 ~ 2V000F	
	3V0000 ~ 3V00FF	3V0000 ~ 3V000F	
Edge Detection	1P0000 ~ 1P01FF	----	
	2P0000 ~ 2P01FF	----	
	3P0000 ~ 3P01FF	----	
Timer	1T0000 ~ 1T01FF	1T0000 ~ 1T001F	
	2T0000 ~ 2T01FF	2T0000 ~ 2T001F	
	3T0000 ~ 3T01FF	3T0000 ~ 3T001F	
Counter	1C0000 ~ 1C01FF	1C0000 ~ 1C001F	
	2C0000 ~ 2C01FF	2C0000 ~ 2C001F	
	3C0000 ~ 3C01FF	3C0000 ~ 3C001F	
Data Register	1D00000 ~ 1D2FFFF	1D0000 ~ 1D2FFF	
	2D00000 ~ 2D2FFFF	2D0000 ~ 2D2FFF	
	3D00000 ~ 3D2FFFF	3D0000 ~ 3D2FFF	
Link Register	1R00000 ~ 1R07FFF	1R0000 ~ 1R07FF	
	2R00000 ~ 2R07FFF	2R0000 ~ 2R07FF	
	3R00000 ~ 3R07FFF	3R0000 ~ 3R07FF	
Special Register	1S00000 ~ 1S03FFF	1S0000 ~ 1S03FF	
	2S00000 ~ 2S03FFF	2S0000 ~ 2S03FF	
	3S00000 ~ 3S03FFF	3S0000 ~ 3S03FF	
Current Value Register	1N00000 ~ 1N01FFF	1N0000 ~ 1N01FF	
	2N00000 ~ 2N01FFF	2N0000 ~ 2N01FF	
	3N00000 ~ 3N01FFF	3N0000 ~ 3N01FF	
File Register	B00000 ~ B1FFFF	B0000 ~ B1FFF	
Exp. Input	EX0000 ~ EX07FF	EX0000 ~ EX007F	
Exp. Output	EY0000 ~ EY07FF	EY0000 ~ EY007F	
Exp. Internal Relay	EM0000 ~ EM1FFF	EM0000 ~ EM01FF	
Exp. Keep Relay	EK0000 ~ EK0FFF	EK0000 ~ EK00FF	
Exp. n Link Relay	EL0000 ~ EL1FFF	EL0000 ~ EL01FF	
Exp. Special Relay	EV0000 ~ EV0FFF	EV0000 ~ EV00FF	
Exp. Edge Relay	EP0000 ~ EP0FFF	----	
Exp. Timer	ET0000 ~ ET07FF	ET0000 ~ ET007F	
Exp. Counter	EC0000 ~ EC07FF	EC0000 ~ EC007F	
Exp. Special Register	ES00000 ~ ES07FFF	ES0000 ~ ES07FF	
Exp. Current Value Register	EN00000 ~ EN07FFF	EN0000 ~ EN07FF	
Exp. Setting Value Register	H00000 ~ H07FFF	H0000 ~ H07FF	
Exp. Data Register	U00000 ~ U7FFFF	U0000 ~ U7FFF	

■ TOYOPUC-PC3J (1:n connection)

In this list, "Exp." means "Expansion".

Setup system area here.

Device	Bit Address	Word Address	Comments
Input	1X0000 ~ 1X03FF	1X0000 ~ 1X003F	L/H
	2X0000 ~ 2X03FF	2X0000 ~ 2X003F	
	3X0000 ~ 3X03FF	3X0000 ~ 3X003F	
Output	1Y0000 ~ 1Y03FF	1Y0000 ~ 1Y003F	
	2Y0000 ~ 2Y03FF	2Y0000 ~ 2Y003F	
	3Y0000 ~ 3Y03FF	3Y0000 ~ 3Y003F	
Internal Relay	1M0000 ~ 1M07FF	1M0000 ~ 007F	
	2M0000 ~ 2M07FF	2M0000 ~ 007F	
	3M0000 ~ 3M07FF	3M0000 ~ 007F	
Keep Relay	1K0000 ~ 1K02FF	1K0000 ~ 1K002F	
	2K0000 ~ 2K02FF	2K0000 ~ 2K002F	
	3K0000 ~ 3K02FF	3K0000 ~ 3K002F	
Link Relay	1L0000 ~ 1L07FF	1L0000 ~ 007F	
	2L0000 ~ 2L07FF	2L0000 ~ 007F	
	3L0000 ~ 3L07FF	3L0000 ~ 007F	
Special Relay	1V0000 ~ 1V00FF	1V0000 ~ 000F	
	2V0000 ~ 2V00FF	2V0000 ~ 000F	
	3V0000 ~ 3V00FF	3V0000 ~ 000F	
Edge Detection	1P0000 ~ 1P01FF	----	
	2P0000 ~ 2P01FF	----	
	3P0000 ~ 3P01FF	----	
Timer	1T0000 ~ 1T01FF	1T0000 ~ 1T001F	
	2T0000 ~ 2T01FF	2T0000 ~ 2T001F	
	3T0000 ~ 3T01FF	3T0000 ~ 3T001F	
Counter	1C0000 ~ 1C01FF	1C0000 ~ 1C001F	
	2C0000 ~ 2C01FF	2C0000 ~ 2C001F	
	3C0000 ~ 3C01FF	3C0000 ~ 3C001F	
Data Register	1D00000 ~ 1D0FFFF	1D0000 ~ 1D0FFF	
	2D00000 ~ 2D0FFFF	2D0000 ~ 2D0FFF	
	3D00000 ~ 3D0FFFF	3D0000 ~ 3D0FFF	
Link Register	1R00000 ~ 1R07FFF	1R0000 ~ 1R07FF	
	2R00000 ~ 2R07FFF	2R0000 ~ 2R07FF	
	3R00000 ~ 3R07FFF	3R0000 ~ 3R07FF	
Special Register	1S00000 ~ 1S03FFF	1S0000 ~ 1S03FF	
	2S00000 ~ 2S03FFF	2S0000 ~ 2S03FF	
	3S00000 ~ 3S03FFF	3S0000 ~ 3S03FF	
Current Value Register	1N00000 ~ 1N01FFF	1N0000 ~ 1N01FF	
	2N00000 ~ 2N01FFF	2N0000 ~ 2N01FF	
	3N00000 ~ 3N01FFF	3N0000 ~ 3N01FF	
File Register	B00000 ~ B0FFFF	B0000 ~ B0FFF	
Exp. Input	EX0000 ~ EX07FF	EX0000 ~ EX007F	
Exp. Output	EY0000 ~ EY07FF	EY0000 ~ EY007F	
Exp. Internal Relay	EM0000 ~ EM0FFF	EM0000 ~ EM01FF	
Exp. Keep Relay	EK0000 ~ EK0FFF	EK0000 ~ EK00FF	
Exp. Link Relay	EL0000 ~ EL0FFF	EL0000 ~ EL01FF	
Exp. Special Relay	EV0000 ~ EV0FFF	EV0000 ~ EV00FF	
Exp. Edge Relay	EP0000 ~ EP0FFF	----	
Exp. Timer	ET0000 ~ ET07FF	ET0000 ~ ET007F	
Exp. Counter	EC0000 ~ EC07FF	EC0000 ~ EC007F	
Exp. Special Register	ES00000 ~ ES07FFF	ES0000 ~ ES07FF	
Exp. Current Value Register	EN00000 ~ EN07FFF	EN0000 ~ EN07FF	
Exp. Setting Value Register	H00000 ~ H07FFF	H0000 ~ H07FF	
Exp. Data Register	U00000 ~ U0FFFF	U0000 ~ U0FFF	



- The range of devices supported may differ for 1:1 communication and for 1:n communication. A maximum of 16 PLCs can be connected.
- When setting tags in GP-PRO/PBIII for Windows, the PLC Station number can be specified during address Input. If a station number is not indicated, the previously entered station number is used. (The default value is 0)

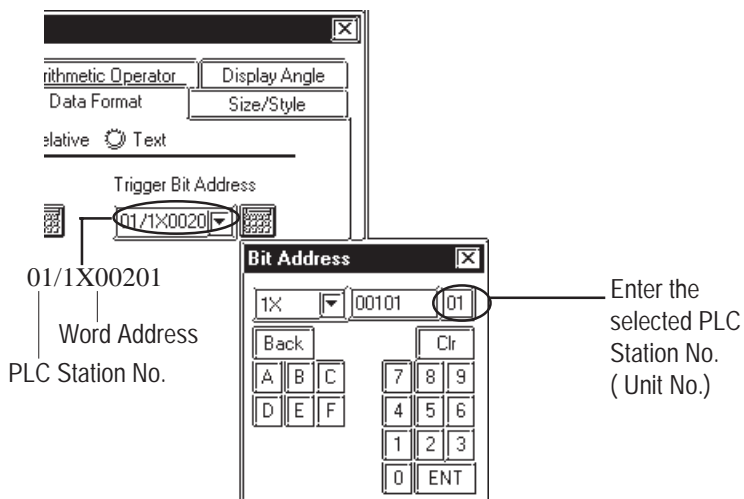

2.9.4 Environment Setup

The following lists Digital's recommended PLC and GP communication settings.

■ **TOYOPUC-PC2 Series (PC2/L2)**

GP Setup		Computer Link Module Setup	
Baud Rate	19200 bps	Baud Rate	19200 bps
Data Length	8 bits	Data Length	8 bits
Stop Bit	1 bit	Stop Bit	1 bit
Parity Bit	Even	Parity Bit	Even
Data Flow Control	ER Control	---	
Communication Format	2-wire type	---	
---		Card Classification	CMP Link
---		SET5	Watch Dog Timer ON
Unit No.	0	Station Number Setting	0

■ **TOYOPUC-PC2 Series (PC2J)**

GP Setup		Computer Link Module Setup	
Baud Rate	19200 bps	Baud Rate	19200 bps
Data Length	8 bits	Data Length	8 bits
Stop Bit	1 bit	Stop Bit	1 bit
Parity Bit	Even	Parity Bit	Even
Data Flow Control	ER Control	---	
Communication Format	2-wire type	---	
---		Internal Switch (SW4)	1 is Off 2 is On
Unit No.	1	Station Number Setting	1

■ TOYOPUC-PC2 Series (PC2J) (1:n connection)

GP Setup		Computer Link Module Setup	
Baud Rate	19200 bps	Baud Rate	19200 bps
Data Length	8 bits	Data Bit	8 bits
Stop Bit	1 bit	Stop Bit	1 bit
Parity Bit	Even	Parity Bit	Even
Data Flow Control	ER Control		---
Communication Format	2-wire type		---
Unit No. ^{*1}	Match this number with that of any PC/CMP link.	Station Number Setting ^{*1}	All PC/CMP link numbers must be different from each other.
	---	Internal Switch (SW4)	1 is Off 2 is On

*1 The memory used for the system area and the read area is allocated to the PLC which has been given the same number as that of the GP.



When entering tag address data in GP-PRO/PBIII for Windows, the PLC Station number can be specified. If a station number is not indicated, the previously entered station number is used. (The initial default value is 1.)

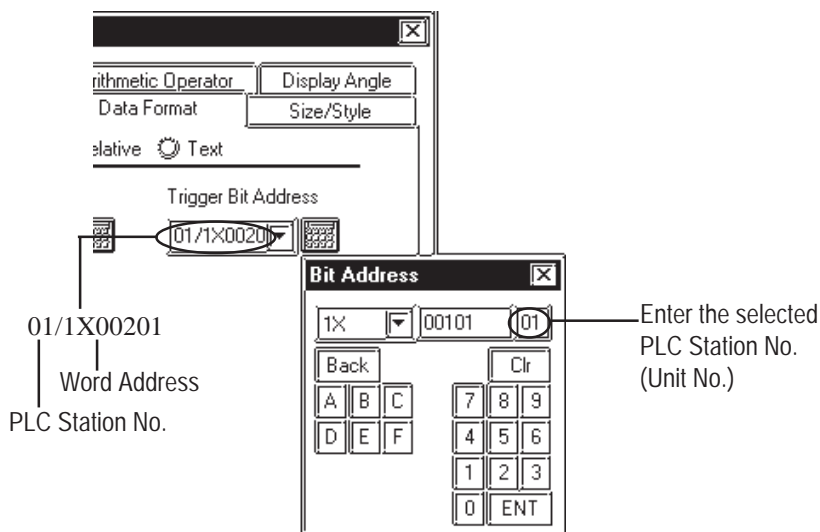

■ TOYOPUC-PC3J (1:1 connection) <Link I/F on CPU unit>

GP Setup		PLC Setup	
Baud Rate ^{*1}	19200 bps	Baud Rate	19200 bps
Data Length	8 bits	Data Length	8 bits
Stop Bit	1 bit	Stop Bit	1 bit
Parity Bit	Even	Parity Bit	Even
Data Flow Control	ER	----	----
Communication Format ^{*2}	4-wire or 2-wire type	RS-422 communication port	4-wire or 2-wire type
Unit No.	0	Station No.	0

*1 The CPU's Link I/F unit maximum baud rate is 57600bps. It does not support 115.2kbps.

*2 Change the communication format depending on the cables you use.

■ TOYOPUC-PC3J (1:n connection) <Link I/F on CPU unit>

GP Setup		PLC Setup	
Baud Rate ^{*1}	19200 bps	Baud Rate	19200 bps
Data Length	8 bits	Data Length	8 bits
Stop Bit	1 bit	Stop Bit	1 bit
Parity Bit	Even	Parity Bit	Even
Data Flow Control	ER	----	----
Communication Format ^{*2}	4-wire or 2-wire type	RS-422 communication port	4-wire or 2-wire type
Unit No.	Select any unit number between 0 to 15. ^{*3}	Station No.	All link station numbers must be different

*1 The CPU's Link I/F unit maximum baud rate is 57600bps. It does not support 115.2kbps.

*2 Change the communication format depending on the cable you use.

*3 A maximum of 16 PLCs can be connected. The PLC's station number must be in base8, however, GP's unit number must be in decimal.

■ TOYOPUC-PC3J (1:1 connection) <PC/CMP-Link>

GP Setup		PLC Setup	
Baud Rate ^{*1}	19200 bps	Baud Rate	19200 bps
Data Length	8 bits	Data Length	8 bits
Stop Bit	1 bit	Stop Bit	1 bit
Parity Bit	Even	Parity Bit	Even
Data Flow Control	ER	----	----
Communication Format	2-wire type	RS-422 communication port ^{*2}	2-wire type
Unit No.	0	Station No.	0

*1 The PC/CMP-Link (THU-2755) unit's maximum baud rate is 57600bps. It does not support 115.2kbps.

*2 With the PC/CMP-Link (THU-2755), only a 2-wire type can be used. When using PC3J commands, the link unit must be version 5.00 or higher.

■ TOYOPUC-PC3J (1:n connection) <PC/CMP-Link>

GP Setup		PLC Setup	
Baud Rate ^{*1}	19200 bps	Baud Rate	19200 bps
Data Length	8 bits	Data Length	8 bits
Stop Bit	1 bit	Stop Bit	1 bit
Parity Bit	Even	Parity Bit	Even
Data Flow Control	ER	----	----
Communication Format	2-wire type	RS-422 communication port ^{*2}	2-wire type
Unit No. ^{*3}	Select any unit number between 0 to 15.	Station No.	All PC/CMP link station numbers must be different
----	----	Internal Switch	SW4-1 OFF SW4-2 ON

*1 The PC/CMP-Link (THU-2755) unit's maximum baud rate is 57600bps. It does not support 115.2kbps.

*2 With the PC/CMP-Link (THU-2755), only a 2-wire type can be used. When using PC3J commands, the link unit must be version 5.00 or higher.

*3 A maximum of 16 PLCs can be connected. The PLC's station number must be in octal, however, GP's unit number must be in decimal.



2.10 Toshiba

2.10.1 System Structure

The following describes the system structure for connecting the GP to Toshiba PLCs.

Reference The Cable Diagrams mentioned in the following tables are listed in the section titled "2.10.2 Cable Diagrams".

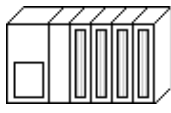
■ PROSEC EX Series (using CPU unit Link I/F)

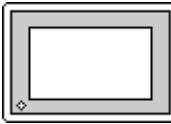

CPU	Cable Diagram	GP
		
EX2000 *1	RS-422 (Cable Diagram 1)	GP series

*1 Connect to the Main Processor module (MPU6620).

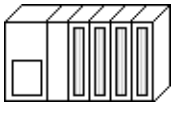

Areas noted as using RS-422 can also use RS-485 on the PLC side.

■ PROSEC T Series (using CPU unit Link I/F)

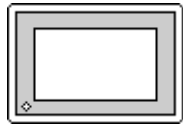



CPU	Link I/F	Cable Diagram	GP
	 Link Master Module		
T3 *1, T3H,	CPU Link I/Funit	RS-422 (Cable Diagram2)	GP Series
T2E	CPU Programming Port	RS-232C (Cable Diagram4)	
T2N	CPU Link I/Funit	RS-422 (Cable Diagram2)	
		RS-232C (Cable Diagram5)	
T2E	CM231E	RS-422 (Cable Diagram1)	

*1 Connect to the CPU module's computer link port.

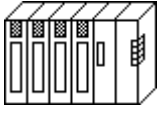

Areas noted as using RS-422 can also use RS-485 on the PLC side.

■ **PROVISOR B Series** (using CPU unit Link I/F)

CPU	Link I/F	Cable Diagram	GP
	 Link Master Module		
B200CU, B200CUF, B200CURM, B200CUFRM	B 2000LM	RS-232C (Cable Diagram 3)	GP Series



When connecting the GP and B200 Series, setup the Link I/F's Mode Setup/Delimiter to **CR**.

2.10.2 Cable Diagrams

The cable diagrams illustrated below and the cable diagrams recommended by Toshiba may differ; however, using these cables for your PLC operations will not cause any problems.



Ground your PLC's FG terminal according to your country's applicable standard. For details, refer to the corresponding PLC manual.



- **Connect the FG line of the Shield cable to either the GP or PLC, depending on your environment. When using a connector hood and grounding the FG line, be sure to use an electrical conductor.**
- **For the RS-232C connection, use a cable length less than 15m.**
- **If a communications cable is used, it must be connected to the SG (signal ground).**
- **When using RS422 connection, please check the length of the cable with Toshiba PLC's users manual.**

Cable Diagram 1 (RS-422)

- When using Digital's RS-422 connector terminal adapter GP070-CN10-0

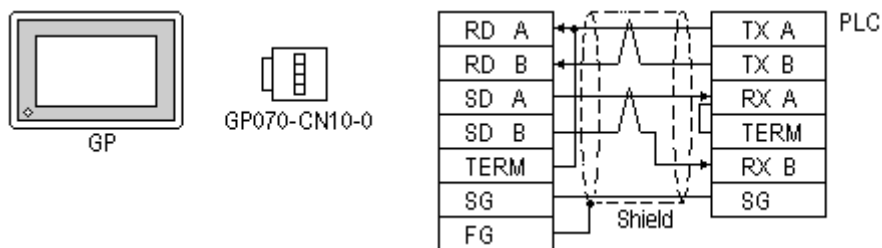

- When using Digital's RS-422 Cable, GP230-IS11-0

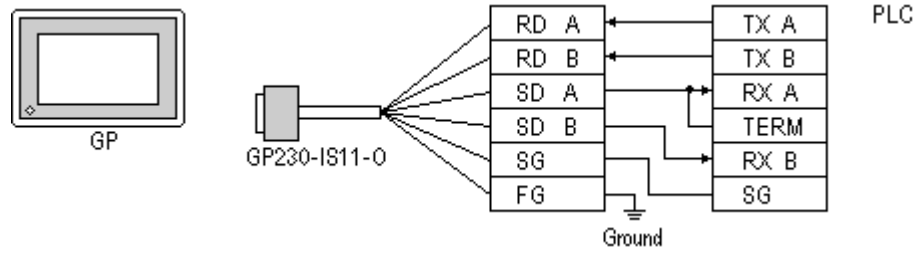

- When making your own cable connections

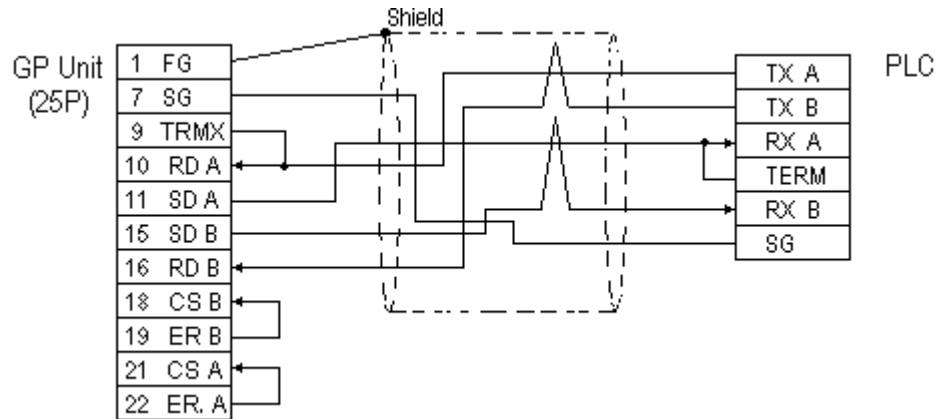

- When making your own connections, we recommend using Hitachi Densen's CO-SPEV-SB(A)3P*0.5 cable.
- When connecting the #9 and #10 pins in the GP Serial I/F, a termination resistance of 100Ω is added between RDA and RDB.

Cable Diagram 2 (RS-422)

- When using Digital's RS-422 connector terminal adapter GP070-CN10-0

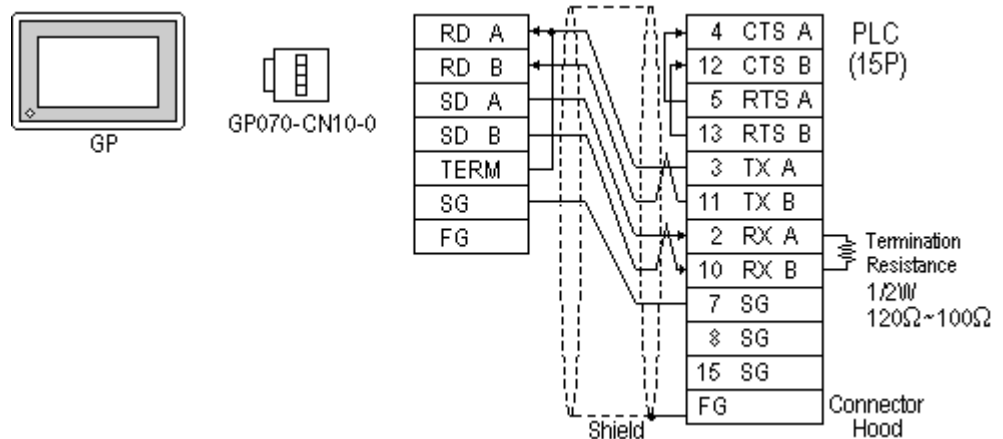

- When using Digital's RS-422 Cable, GP230-IS11-0

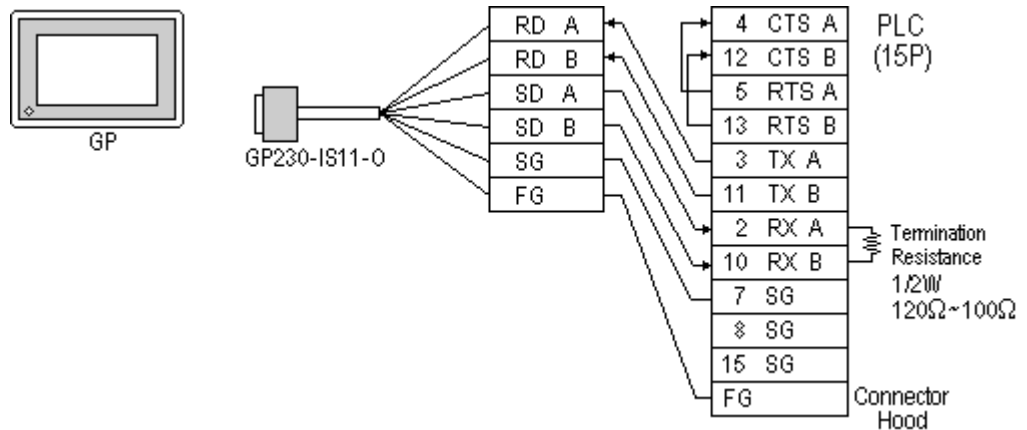

- When making your own cable connections

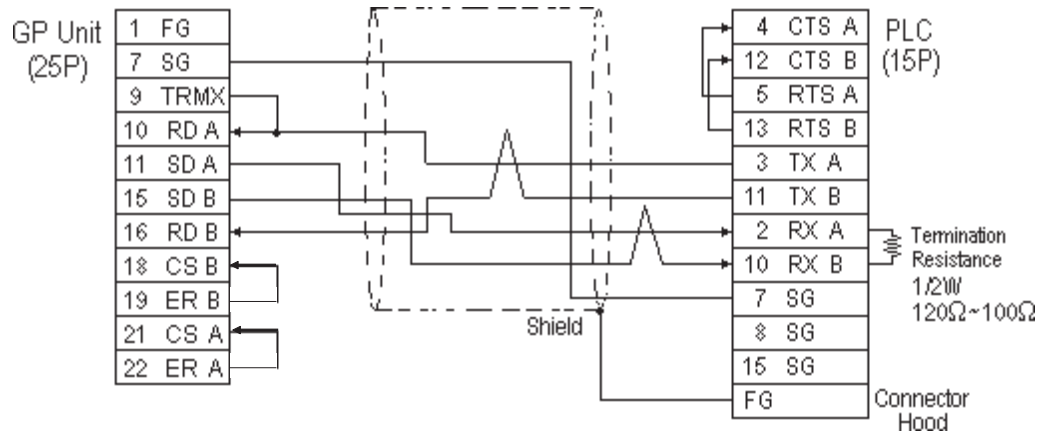

- When making your own connections, we recommend using Hitachi Densen's CO-SPEV-SB(A)3P*0.5 cable.
- When connecting the #9 and #10 pins in the GP Serial I/F, a termination resistance of 100Ω is added between RDA and RDB.
- When using RS422 connection, please check the length of the cable with Toshiba PLC's users manual.

Cable Diagram 3 (RS-232C)

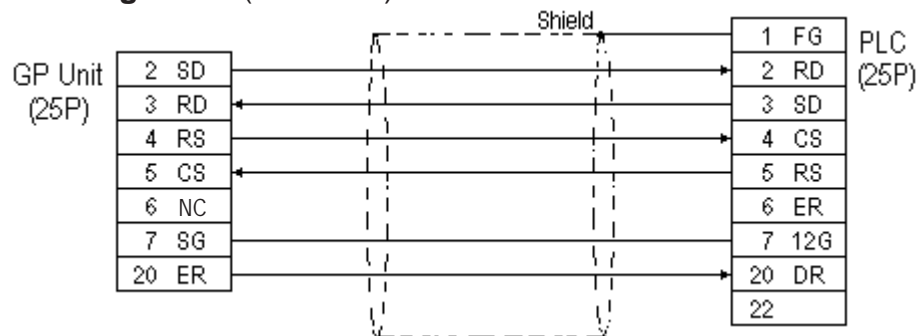

Cable Diagram 4 (RS-232C)

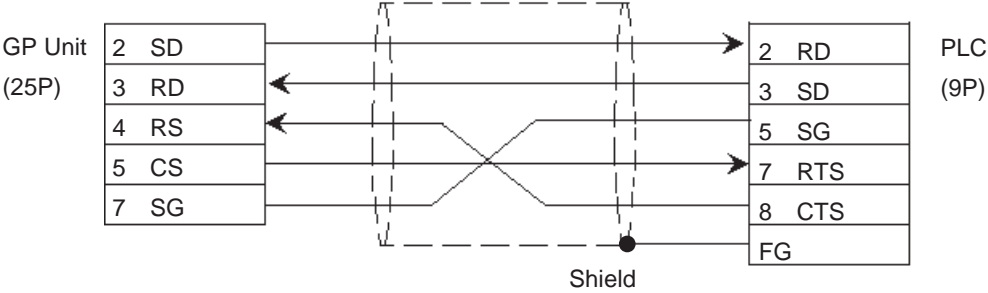

Cable Diagram 5 (RS-232C)

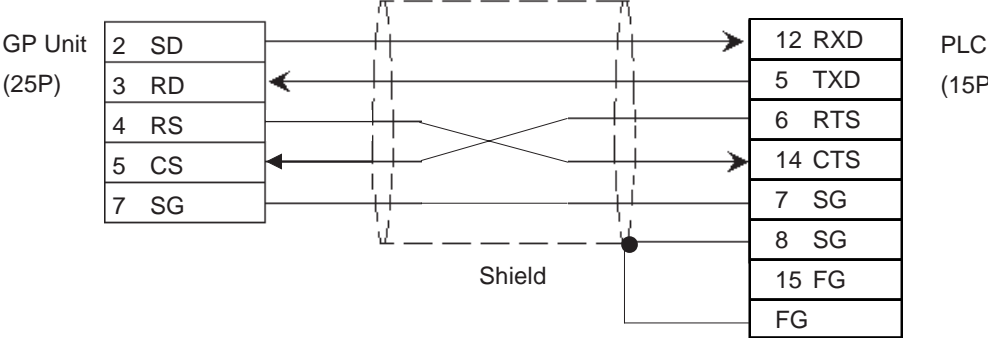

2.10.3 Supported Devices

The following describes the range of devices supported by the GP.

■ PROSEC EX Series

 Setup System Area here.

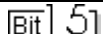
Device	Bit Address	Word Address	Particulars
External Input	X00000 ~ X0499F	XW0000 ~ XW0499	H/L
External Output	Y00000 ~ Y0499F	YW0000 ~ YW0499	
Auxiliary Relay	R00000 ~ R0999F	RW0000 ~ RW0999	
Link Register (relay)	Z00000 ~ Z0999F	ZW0000 ~ ZW1999	
Timer (contact)	T0000 ~ T0499	---	
Counter (contact)	C0000 ~ C0499	---	
Timer (current value)	---	T0000 ~ T0499	L/H
Counter (current value)	---	C0000 ~ C0499	
Data Register	---	D00000 ~ D16383	 H/L

■ PROSEC T Series(T3,T3H,T2N,T2E)

 Setup System Area here.

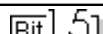
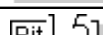
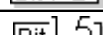
Device	Bit Address	Word Address	Particulars	
External Input	X0000 ~ X511F	XW0000 ~ XW511	L/H	
External Output	Y0000 ~ Y511F	YW0000 ~ YW511		
Internal Relay	R0000 ~ R999F	RW000 ~ RW999		
Special Relay	S0000 ~ S255F	SW000 ~ SW255		
Link Register Relay	Z0000 ~ Z999F	---		
Link Relay	L0000 ~ L255F	---		
Timer (contact)	T000 ~ T999	---		*1
Counter (contact)	C000 ~ C511	---		*1
Timer (current value)	---	T000 ~ T999		
Counter (current value)	---	C000 ~ C511		
Data Register	---	D0000 ~ D8191		
Link Register	---	W0000 ~ W2047		
File Register	---	F0000 ~ F32767		

* 1 Data cannot be written.



Note: The Device Range may differ depending on the CPU type. For the details, refer to the Toshiba's PLC manual.

■ **PROVISOR B Series**

Setup System Area here.

Device	Bit Address	Word Address	Particulars
Input Relay	X000 ~ XF7F	XW00 ~ XWF7	*1
Output Relay	Y000 ~ YF7F	YW00 ~ YWF7	*1
Internal Relay	R000 ~ R77F	RW00 ~ RW77	*1
Extended Internal Relay-1	G000 ~ GF7F	GW00 ~ GWF7	*1
Extended Internal Relay-2	H000 ~ HF7F	HW00 ~ HWF7	*1
Special AUX Relay	A000 ~ A16F	AW00 ~ AW16	*1
Latch Relay	L000 ~ L07F	LW00 ~ LW07	*1
Shift Register	S000 ~ S07F	SW00 ~ SW07	*1
Edge Relay	E000 ~ E77F	EW00 ~ EW77	*1
Timer (contact)	T000 ~ T77F	TW00 ~ TW77	*1
Counter (contact)	C000 ~ C77F	CW00 ~ CW77	*1
Timer/Counter (current value)	P0000 ~ P77FF	P000 ~ P77F	
Timer/Counter (setup value)	V0000 ~ V77FF	V000 ~ V77F	
Generic Register 1	D0000 ~ DF7FF	D000 ~ DF7F	
Generic Register 2	B0000 ~ BF7FF	B000 ~ BF7F	

L/H

* 1 Be careful as the Word Address fields differ between the GP screen editing software GP-PRO/PBIII for Windows and the corresponding PLC manual.

E.g. Input Relay

PRO-PBIII	PLC Manual
XW00 ~ XWF7	X00W ~ XF7W



When the *Input Relay* address is setup in a ladder program input field, Set/Reset cannot be performed from the GP. The same holds true for an address (all devices) setup in an output field.

2.10.4 Environment Setup

The following lists Digital's recommended PLC and GP communication settings.

■ PROSEC EX Series

GP Setup		Main Processor Module/CPU Module Setup	
Baud Rate	9600 bps	Baud Rate	9600 bps
Data Length	8 bits	Data Bit	8 bits
Stop Bit	1 bit	Stop Bit	1 bit
Parity Bit	Odd	Parity Bit	Odd
Data Flow Control	ER Control	---	
Communication Format	4-wire type	---	
Unit No.	1	Station Number	1

■ PROSEC T Series

GP Setup		CPU Module Setup	
Baud Rate	19200 bps ^{*1*2}	Baud Rate	19200 bps ^{*1*2}
Data Length	8 bits ^{*2}	Data Bit	8 bits ^{*2}
Stop Bit	2 bits ^{*2}	Stop Bit	2 bits ^{*2}
Parity Bit	Odd	Parity Bit	Odd
Data Flow Control	ER Control	---	
Communication Format (RS-232C)	RS-232C	---	
Communication Format (RS-422)	4-wire type	---	
Unit No.	1	Station Number	1

*1 PLC specifications state that when a PROSEC T3 (Ver. 1.4 or lower) is used, data transmission is possible only at speeds of 9600 bps or less.

*2 The T2E uses a baud rate of 9600bps, a data length of 8bits and the stop bit is 1(fixed).

■ PROVISOR B Series

GP Setup		Link Master Module Setup	
Baud Rate	9600 bps	Baud Rate	9600 bps
Data Length	8 bits	Data Bit	8 bits
Stop Bit	2 bits	Stop Bit	2 bits
Parity Bit	Even	Parity Bit	Even
Data Flow Control	ER Control	---	
Communication Format	RS-232C	---	
---		Operation Mode	Link Mode
Unit No.	0	Station Number	0

2.11 Toshiba Machine

2.11.1 System Structure





The following describes the system structure for connecting the GP to Toshiba Machine PLCs.

Reference The Cable Diagrams mentioned in the following tables are listed in the section titled "2.11.2 Cable Diagrams".

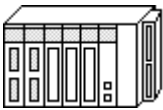

Note: Match up the GP Unit No. and each PC Number when multiple PCs are connected using PC Link.

■ PROVISOR TC200 Series (using Link I/F)

CPU	Link I/F	Cable Diagram	GP
	 SIO Module		
TCCUH	TCCMW TCCMO Link I/F on CPU ^{*1}	RS-232C (Cable Diagram 1)	GP Series

*1 Connect to the RS-232C connector.

2.11.2 Cable Diagrams

The cable diagrams illustrated below and the cable diagrams recommended by Toshiba Machine may differ, however, using these cables for your PLC operations will not cause any problems.



Ground your PLC's FG terminal according to your country's applicable standard. For details, refer to the corresponding PLC manual.



- **Connect the FG line of the Shield cable to either the GP or PLC, depending on your environment. When using a connector hood and grounding the FG line, be sure to use an electrical conductor.**
- **For the RS-232C connection, use a cable length less than 15m.**
- **If a communications cable is used, it must be connected to the SG (signal ground).**

Cable Diagram 1 (RS-232C)

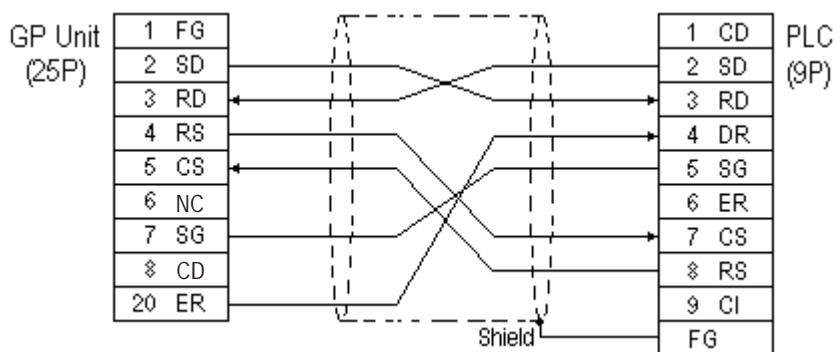

2.11.3 Supported Devices

The following describes the range of devices supported by the GP.

PROVISOR TC200 Series

 Setup System Area here.

Device	Bit Address	Word Address	Particulars
Input Relay	X000 ~ XF7F	XW00 ~ XWF7	*1*2
Output Relay	Y000 ~ YF7F	YW00 ~ YWF7	*1*2
Internal Relay	R000 ~ R77F	RW00 ~ RW77	*1*2
Extended Internal Relay-1	G000 ~ GF7F	GW00 ~ GWF7	*1*2
Extended Internal Relay-2	H000 ~ HF7F	HW00 ~ HWF7	*1*2
Special AUX Relay	A000 ~ A16F	AW00 ~ AW16	*1*2
Latch Relay	L000 ~ L07F	LW00 ~ LW07	*1*2
Shift Register	S000 ~ S07F	SW00 ~ SW07	*1*2
Edge Relay	E000 ~ E77F	EW00 ~ EW77	*1*2
Timer (contact)	T000 ~ T77F	TW00 ~ TW77	*1*2
Counter (contact)	C000 ~ C77F	CW00 ~ CW77	*1*2
Timer/Counter (current value)	—	P000 ~ P77F	*3
Timer/Counter (setup value)	—	V000 ~ V77F	*3
Generic Register 1	—	D000 ~ DF7F	*3
Generic Register 2	—	B000 ~ BF7F	*3

L/H

*1 Be careful as the Word Address fields differ between the GP screen editing software GP-PRO/PBIII for Windows and the corresponding PLC manual.

E.g. Input Relay

GP-PRO/PBIII	PLC Manual
XW00~XWF7	X00W~XF7W

*2 In the screen creation software, the word address' last digit is hexadecimal and you can enter any number between 0 and F as the last digit, however, PLC's word address' last digit is octal and you can only enter a number between 0 to 7 as the last digit.

*3 In the screen creation software, the word address' second last digit is hexadecimal and you can enter any number between 0 and F as second last digit, however, PLC's word address' second last digit is octal and you can only enter a number between 0 to 7 as the second last digit .

(See Next Page)



When the Input Relay address is setup in a ladder program input field, Set/Reset cannot be performed from the GP. The same holds true for an address (all devices) setup in an output field.



- When writing blocked (grouped) data in, any data cannot be input if it has to be carried in excess of the octal-decimal digits.
- A device cannot be read out individually during it is read out as one of the blocked (grouped) data.

Example: The Tag which reads out 17 words from GW0 and the tag which reads out GW10 only cannot be set up at the same time.



Important *Within the Reading area you can use a maximum of 108 words, starting from the last two digits "00". If you enter more than 108 words, the error message "PLC COM. ERROR (02:CA)" will appear.*

2.11.4 Environment Setup

The following lists Digital's recommended PLC and GP communication settings.

■ **PROVISOR TC200 Series (using SIO module)**

GP Setup		SIO Module Setup	
Baud Rate	9600 bps	Baud Rate	9600 bps
Data Length	8 bits	Data Bit	8 bits
Stop Bit	2 bits	Stop Bit	2 bits
Parity Bit	None	Parity Bit	None
Data Flow Control	ER Control	---	
Communication Format	RS-232C	---	
---		Select Function Switch	3 is On
Unit No.	0	PC Number	0

■ **PROVISOR TC200 Series (using RS-232C Connector)**





GP Setup		RS-232C Connector Setup	
Baud Rate	9600 bps	Baud Rate	9600 bps
Data Length	8 bits	Data Bit	8 bits
Stop Bit	2 bits	Stop Bit	2 bits
Parity Bit	None	Parity Bit	None
Data Flow Control	ER Control	---	
Communication Format	RS-232C	---	
Unit No.	64 (fixed)	---	

2.12 Koyo Electronics Industries

2.12.1 System Structure

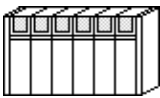



The following describes the system structure for connecting the GP to Koyo Electronics Industries PLCs.

Reference The Cable Diagrams mentioned in the following tables are listed in the section titled "2.12.2 Cable Diagrams".

CPU	Link I/F	Cable Diagram	GP
	 Upper Link Module		
SG-8	G01-DM	RS-232C (Cable Diagram 1)	GP series
		RS-422 (Cable Diagram 2)	
	CPU Unit Upper Link I/F *1	RS-232C (Cable Diagram 1)	
		RS-422 (Cable Diagram 3)	

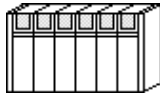
*1 Connect to the CPU module's generic communication port.

■ KOSTAC SU Series (using Link I/F)

CPU	Link I/F	Cable Diagram	GP
	 Upper Link Module		
SU-5	U01-DM	RS-232C (Cable Diagram 1)	GP series
SU-6	U01-DM		
	CPU Unit Upper Link I/F *1		
SU-6B	CPU Unit Upper Link I/F *1	RS-232C (Cable Diagram 1)	
		RS-422 (Cable Diagram 3)	



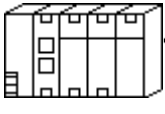
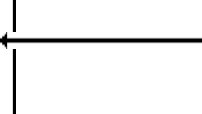
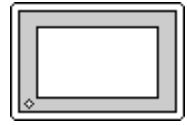

*1 Connect to the CPU module's generic communication port.

■ **KOSTAC SZ Series** (using CPU unit Link I/F)



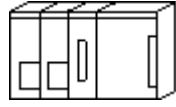

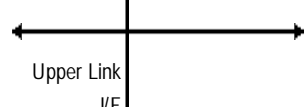
CPU	Cable Diagram	GP
		
SZ-4 ^{*1}	RS-232C (Cable Diagram 4)	GP series

* 1 Connect to the CPU module's generic communication port.

■ **KOSTAC SR Series** (using Upper Link I/F)

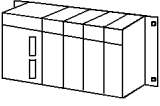
CPU	Link I/F	Cable Diagram	GP
			
SR-21 SR-22	E-02DM-R1	RS-422 (Cable Diagram 2)	GP series

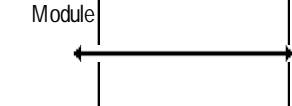
■ **DL-405 Series** (using Link I/F)



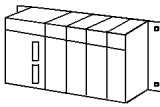
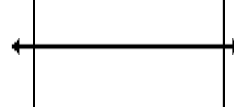
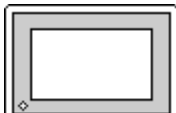

CPU	Link I/F	Cable Diagram	GP
			
D4-430	D4-DCM	RS-232C (Cable Diagram 1)	GP series
D4-440	Link I/F on CPU unit		

■ **DL-205 Series** (using Link I/F on CPU unit)

CPU	Cable Diagram	GP
		
D2-240 ^{*1}	RS-232C (Cable Diagram 5)	GP series

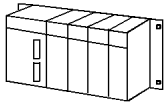
* 1 Connect to the CPU module's generic communication port.

■ DL-305 Series (using Link I/F on CPU unit)

CPU	Link I/F	Cable Diagram	GP
	 Upper Link I/F		
D3-330	D3-DCM	RS-422 (Cable Diagram 2)	GP

2.12.2 Cable Diagrams

The cable diagrams illustrated below and the cable diagrams recommended by Koyo Electronic Industries may differ, however, using these cables for your PLC operations will not cause any problems.



Ground your PLC's FG terminal according to your country's applicable standard. For details, refer to the corresponding PLC manual.



- **Connect the FG line of the Shield cable to either the GP or PLC, depending on your environment. When using a connector hood and grounding the FG line, be sure to use an electrical conductor.**
- **For the RS-232C connection, use a cable length less than 15m.**
- **If a communications cable is used, it must be connected to the SG (signal ground).**
- **For the RS-422 connection, use a cable length less than 600m.**

Cable Diagram 1 (RS-232C)

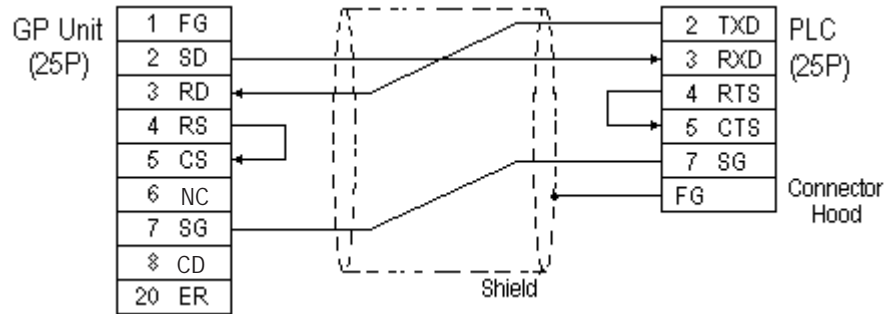

Cable Diagram 2 (RS-422)

- When using Digital's RS-422 connector terminal adapter GP070-CN10-0

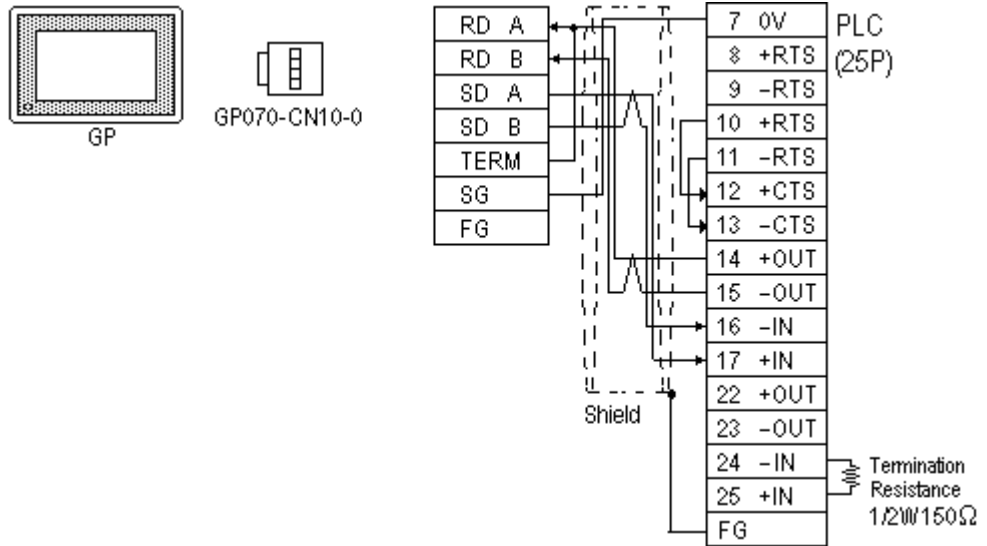

- When using Digital's RS-422 Cable, GP230-IS11-0

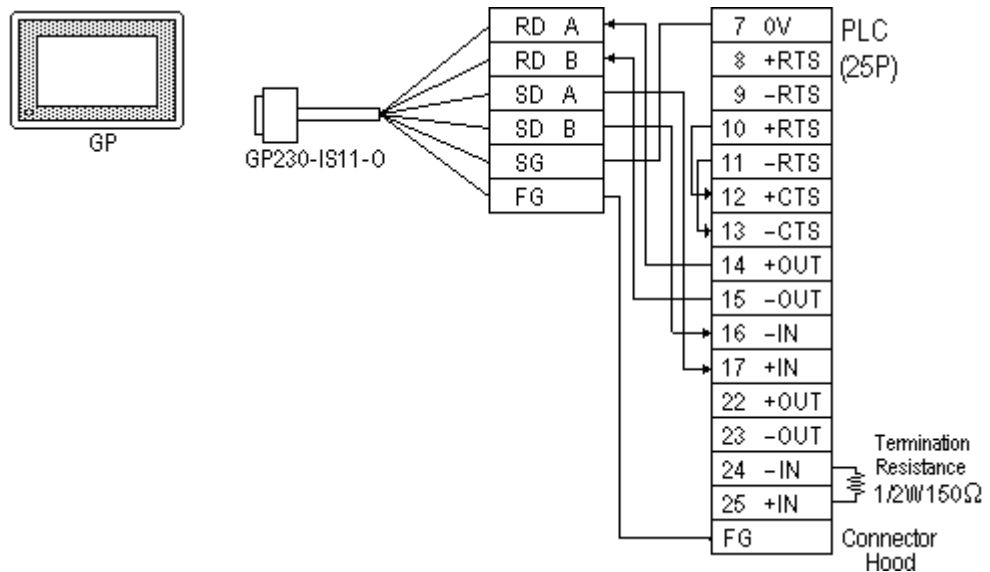

- When making your own cable connections

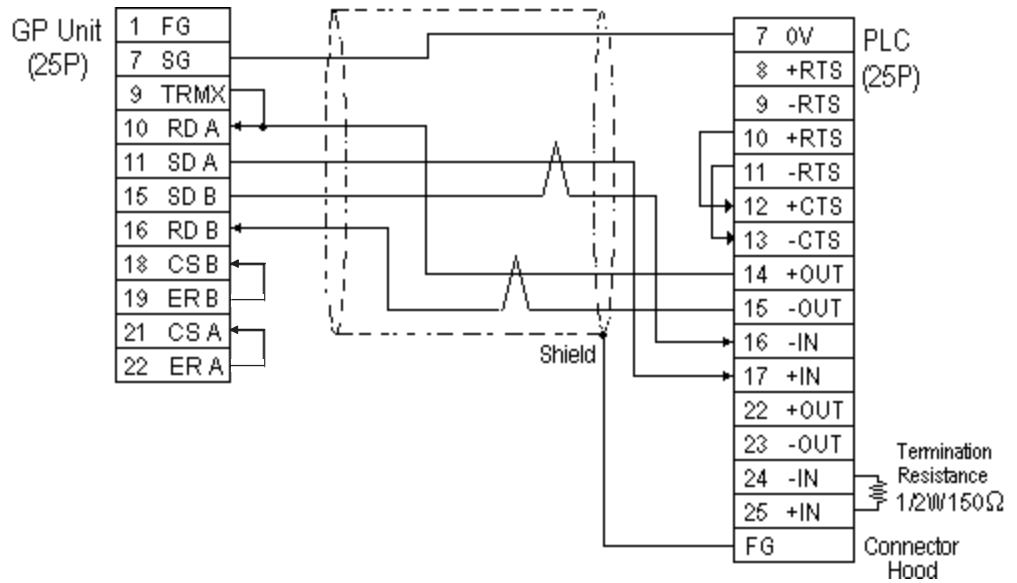

- When making your own connections, we recommend using Hitachi Densen's CO-SPEV-SB(A)3P*0.3SQ cable.
- When connecting the #9 and #10 pins in the GP Serial I/F, a termination resistance of 100Ω is added between RDA and RDB.
- When using RS-422 connection, the cable length must not be any longer than 600 meters.

Cable Diagram 3 (RS-422)

- When using Digital's RS-422 connector terminal adapter GP070-CN10-0

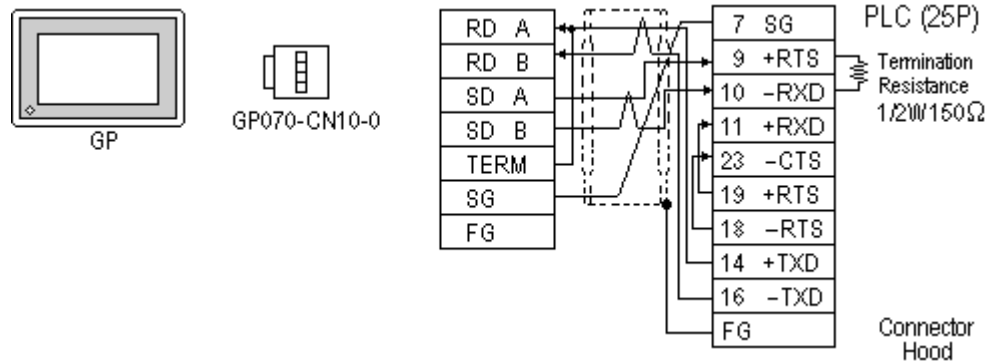

- When using Digital's RS-422 Cable, GP230-IS11-0

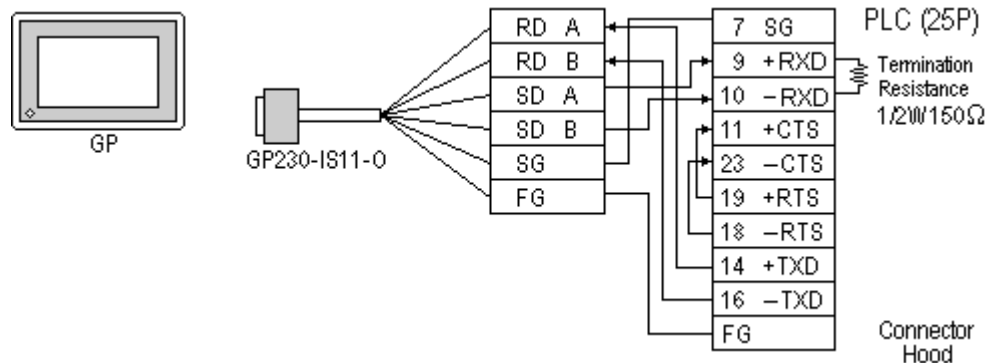

- When making your own cable connections

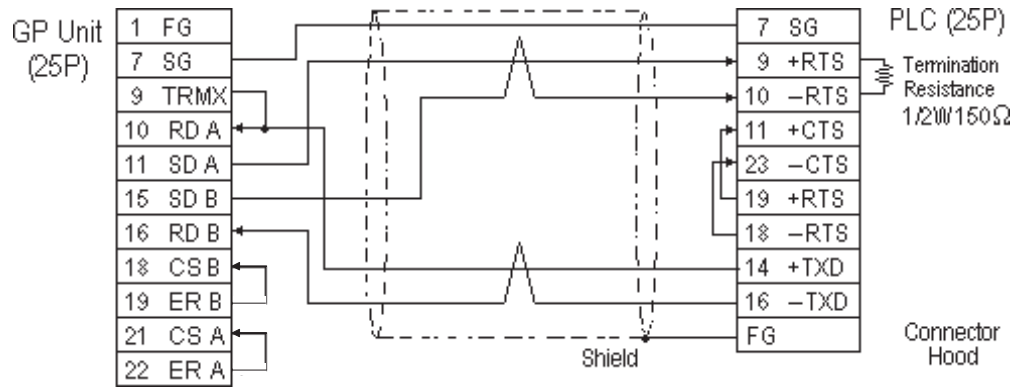

- When making your own connections, we recommend using Hitachi Densen's CO-SPEV-SB(A)3P*0.3SQ cable.
- When connecting the #9 and #10 pins in the GP Serial I/F, a termination resistance of 100Ω is added between RDA and RDB.
- When using RS-422 connection, the cable length must not be any longer than 600 meters.

Cable Diagram 4 (RS-232C)

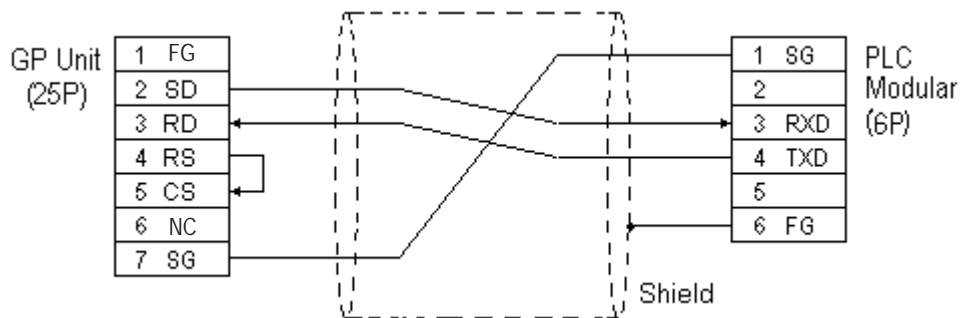

The GP connection uses SZ-4's Port 2 (generic SIO port). Port 1 is the program communication port (Programming Console S-20P).

Cable Diagram 5 (RS-232C)

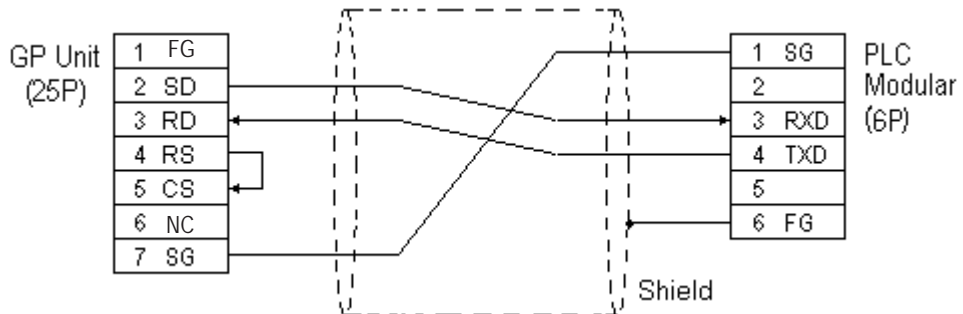

















The GP connection uses D2-240's Port 2 (generic SIO port). Port 1 is the program communication port.

2.12.3 Supported Devices

The following describes the range of devices supported by the GP.

















■ **KOSTAC SG Series**

 Setup System Area here.

Device	Bit Address	Word Address	Particulars	
Input Relay	I0000 ~ I1777	R40400 ~ R40477		L/H
Output Relay	Q0000 ~ Q1777	R40500 ~ R40577		
Control Relay	M0000 ~ M3777	R40600 ~ R40777		
Stage	S0000 ~ S1777	R41000 ~ R41077		
Link Relay (input)	GI0000 ~ GI3777	R40000 ~ R40177		
Specified Transfer Relay (output)	GQ0000 ~ GQ3777	R40200 ~ R40377		
Timer (contact)	T000 ~ T377	R41100 ~ R41117		
Counter (contact)	C000 ~ C377	R41140 ~ R41157		
Timer (elapsed time)	---	R0000 ~ R0377		
Counter (elapsed value)	---	R1000 ~ R1377		
Variable Memory 1	---	R400 ~ R777	 	
Variable Memory 2	---	R1400 ~ R7377	 	
Variable Memory 3	---	R10000 ~ R37777	 	

■ **KOSTAC SU Series**

 Setup System Area here.











Device	Bit Address	Word Address	Particulars	L/H
Input Relay	I000 ~ I477	R40400 ~ R40423		
Output Relay	Q000 ~ Q477	R40500 ~ R40523		
Control Relay	M0000 ~ M1777	R40600 ~ R40677		
Stage	S0000 ~ S1777	R41000 ~ R41077		
Link Relay/Link Input	GI0000 ~ GI1777	R40000 ~ R40077		
Special Relay	SP000 ~ SP137 SP320 ~ SP717	R41200 ~ R41205 R41215 ~ R41234	 ^{*1}	
Timer (contact)	T000 ~ T377	R41100 ~ R41117		
Counter (contact)	C000 ~ C177	R41140 ~ R41157		
Timer (elapsed time)	---	R0000 ~ R0377		
Counter (elapsed value)	---	R1000 ~ R1177		
Data Register	---	R1400 ~ R7377	 	
Special Register	---	R700 ~ R737 R7400 ~ R7777	  ^{*1}	
Expanded Register	---	R10000 ~ R17777	  ^{*2}	

*1 Only the SU-6B will check connections (Only the SU-6B can use special registers R700 to R737), however it cannot write data.

*2 Only the SU-6B can be used.







■ **KOSTAC SZ Series**

 Setup System Area here.

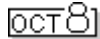
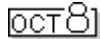
Device	Bit Address	Word Address	Particulars	L/H
Input Relay	I000 ~ I0477	R40400 ~ R40423		
Output Relay	Q0000 ~ Q0477	R40500 ~ R40523		
Control Relay	M0000 ~ Q0377	R40600 ~ R40617		
Stage	---	R41000 ~ R41037		
Timer (contact)	T000 ~ T177	R41100 ~ R41107		
Counter (contact)	C000 ~ C177	R41140 ~ R41147		
Timer (elapsed time)	---	R0000 ~ R0177		
Counter (elapsed value)	---	R1000 ~ R1177		
Variable Memory 2	---	R2000 ~ R3777	 	

■ **KOSTAC SR Series**

 Setup System Area here.

Device	Bit Address	Word Address	Particulars
Input/Output	000 ~ 157	R000 ~ R014	
	700 ~ 767	R070	
Control Relay	160 ~ 377	R016 ~ R036	
	770 ~ 777	R076	
Shift Register	400 ~ 577	R040 ~ R056	
Timer/Counter (contact)	600 ~ 677	R060 ~ R066	
Timer/Counter (elapsed value)	---	R600 ~ R677	
Data Register	---	R400 ~ R577	  















L/H

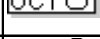

Cannot perform only bit write operations. Use byte units to perform bit write operations, where all other bits besides the selected bit, are cleared to 0.

■ **DL-405 Series**









 Setup System Area here.

Device	Bit Address	Word Address	Particulars
Input Relay	X000 ~ X477	V40400 ~ V40423	
Output Relay	Y000 ~ Y477	V40500 ~ V40523	
Internal Relay	C0000 ~ C1777	V40600 ~ V40677	
Stage	S0000 ~ S1777	V41000 ~ V41077	
Link Relay/Link Input	GX0000 ~ GX1777	V40000 ~ V40077	
Special Relay	SP000 ~ SP137	V41200 ~ V41205	
	SP320 ~ SP717	V41215 ~ V41234	
Timer (contact)	T000 ~ T377	V41100 ~ V41117	
Counter (contact)	CT000 ~ CT177	V41140 ~ V41147	
Timer (elapsed time)	---	V0000 ~ V0377	
Counter (elapsed value)	---	V1000 ~ V1177	
Data Register	---	V1400 ~ V7377	 
Special Register	---	V7400 ~ V7777	 

L/H







■ DL-205 Series

 Setup System Area here.

Device	Bit Address	Word Address	Particulars
Input Relay	X0000 ~ X0477	V40400 ~ V40423	
Output Relay	Y0000 ~ Y0477	V40500 ~ V40523	
Control Relay	C0000 ~ C0377	V40600 ~ V40617	
Stage	---	V41000 ~ V41037	
Timer (contact)	T000 ~ 177	V41100 ~ V41107	
Counter (contact)	CT000 ~ CT177	V41140 ~ V41147	
Timer (elapsed time)	---	V0000 ~ V0177	
Counter (elapsed value)	---	V1000 ~ V1177	
Variable Memory 2	---	V2000 ~ V3777	 Bit 5

■ DL-305 Series

 Setup System Area here.

Device	Bit Address	Word Address	Particulars
Input/Output	000 ~ 157 700 ~ 767	V000 ~ V014 V070	
Control Relay	160 ~ 377 770 ~ 777	V016 ~ V036 V076	
Shift Register	400 ~ 577	V040 ~ V056	
Timer/Counter (contact)	600 ~ 677	V060 ~ V066	
Timer/Counter (elapsed value)	---	V600 ~ V677	
Data Register	---	V400 ~ V577	 Bit 5 

2.12.4 Environment Setup

The following tables list Digital's recommended PLC and GP communication settings.

■ KOSTAC SG Series (using Upper Link I/F)

GP Setup		Upper Link Module Setup	
Baud Rate	19200 bps	Baud Rate	19200 bps
Data Length	8 bits	---	
Stop Bit	1 bit	---	
Parity Bit	Odd	Parity Bit	Odd
Data Flow Control	ER Control	---	
Communication Format (RS-232C)	RS-232C	---	
Communication Format (RS-422)	4-wire type	---	
---		Master/Slave Setup	Slave
---		Transfer Mode	Hex
Unit No.	1	Station Number	1

■ KOSTAC SG Series (using General SIO Port)

GP Setup		Generic SIO Port Setup	
Baud Rate	19200 bps (fixed)	Baud Rate	19200 bps (fixed)
Data Length	8 bits (fixed)	Data Length	8 bits (fixed)
Stop Bit	1 bit (fixed)	Stop Bit	1 bit (fixed)
Parity Bit	Odd (fixed)	Parity Bit	Odd (fixed)
Data Flow Control	ER Control	---	
Communication Format (RS-232C)	RS-232C	Communication Format (RS-232C)	Dipswitch 1 (CCM SIO Port) is ON
Communication Format (RS-422)	4-wire type	Communication Format (RS-422)	Dipswitch 4 (CCM SIO Port) is Off
---		Transfer Mode ^{*1}	Hex
Unit No.	1	CCM Number ^{*1}	1

**1 Turn Dip Switch 2 (CCM Station No.) OFF, and run Transfer mode and CCM Station Number setup with the programmer. Communication will not occur when Dip Switch 2 is ON and the transfer Mode is not designated as Hex.*

■ KOSTAC SU Series (using Upper Link I/F)

GP Setup		Generic Link Module Setup	
Baud Rate	19200 bps	Baud Rate	19200 bps
Data Length	8 bits (fixed)	---	
Stop Bit	1 bit (fixed)	---	
Parity Bit	Odd	Parity Bit	Odd
Data Flow Control	ER Control	---	
Communication Format	RS-232C	---	
Unit No.	1	Station Number	1

■ KOSTAC SU Series (using General SIO Port)

GP Setup		Generic SIO Port Setup	
Baud Rate	19200 bps	Baud Rate	19200 bps
Data Length	8 bits (fixed)	---	
Stop Bit	1 bit (fixed)	---	
Parity Bit	Odd	Parity Bit	Odd
Data Flow Control	ER Control	---	
Communication Format (RS-232C)	RS-232C	---	
Communication Format (RS-422)	4-wire type	---	
---		Data Format *1	Hex
Unit No.	1	Station Number	1

*1 Turn Dip Switch 2 (CCM Station No.) OFF, and run Transfer mode and CCM Station Number setup with the programmer. Communication will not occur when Dip Switch 2 is ON and the transfer Mode is not designated as Hex.

■ KOSTAC SZ Series

GP Setup		Generic SIO Port Setup	
Baud Rate	9600 bps	Baud Rate	9600 bps
Data Length	8 bits	Data Length	8 bits
Stop Bit	1 bit	Stop Bit	1 bit
Parity Bit	Odd	Parity Bit	Odd
Data Flow Control	ER Control	---	
Communication Format	RS-232C	---	
---		Data Format *1	Hex
Unit No.	1	Station Number	1

*1 Turn Dip Switch 2 (CCM Station No.) OFF, and run Transfer mode and CCM Station Number setup with the programmer. Communication will not occur when Dip Switch 2 is ON and the transfer Mode is not designated as Hex.

■ KOSTAC SR Series

GP Setup		CPU Module Setup	
Baud Rate	19200 bps	Baud Rate	19200 bps
Data Length	8 bits	---	
Stop Bit	1 bit	---	
Parity Bit	None	Parity Bit	None
Data Flow Control	ER Control	---	
Communication Format	4-line	---	
---		Turn Around Relay	No delay
---		Power Up Mode	RUN mode
---		Transmission Mode	Hex
Unit No.	1	Station Number	1

■ **DL405 Series** (using Upper Link I/F)

GP Setup		Upper Link Module Setup	
Baud Rate	19200 bps	Baud Rate	19200 bps
Data Length	8 bits (fixed)	---	
Stop Bit	1 bit (fixed)	---	
Parity Bit	Odd	Parity Bit	Odd
Data Flow Control	ER Control	---	
Communication Format	RS-232C	---	
Unit No.	1	Station Number	1

■ **DL-405 Series** (using General SIO Port)

GP Setup		Generic SIO Port Setup	
Baud Rate	19200 bps	Baud Rate	19200 bps
Data Length	8 bits (fixed)	---	
Stop Bit	1 bit (fixed)	---	
Parity Bit	Odd	Parity Bit	Odd
Data Flow Control	ER Control	---	
Communication Format (RS-232C)	RS-232C	---	
Communication Format (RS-422)	4-wire type	---	
---		Data Format *1	Hex
Unit No.	1	Station Number	1

*1 Turn Dip Switch 2 (CCM Station No.) OFF, and run Transfer mode and CCM Station Number setup with the programmer. Communication will not occur when Dip Switch 2 is ON and the transfer Mode is not designated as Hex.

■ **DL-205 Series**

GP Setup		Generic SIO Port Setup	
Baud Rate	9600 bps	Baud Rate	9600 bps
Data Length	8 bits	Data Length	8 bits
Stop Bit	1 bit	Stop Bit	1 bit
Parity Bit	Odd	Parity Bit	Odd
Data Flow Control	ER Control	---	
Communication Format	RS-232C	---	
---		Data Format	Hex
Unit No.	1	Station Number	1

■ DL-305 Series

GP Setup		CPU Module Setup	
Baud Rate	19200 bps	Baud Rate	19200 bps
Data Length	8 bits	---	
Stop Bit	1 bit	---	
Parity Bit	None	Parity Bit	None
Data Flow Control	ER Control	---	
Communication Format	4-wire type	---	
---		Turn Around Relay	No delay
---		Power Up Mode	RUN mode
---		Transmission Mode	Hex
Unit No.	1	Station Number	1



2.13 GE Fanuc Automation

2.13.1 System Structure

The following describes the system structure for connecting the GP to GE Fanuc PLCs.

Reference The Cable Diagrams mentioned in the following tables are listed in the section titled "2.13.2 Cable Diagrams".

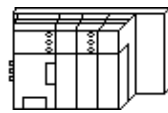
■ Series 90-30 (using SNP-X Protocol/Link I/F)

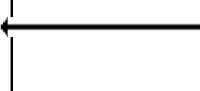
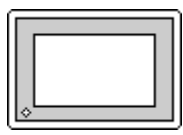
CPU	Link I/F	Cable Diagram	GP
	Communication Module 		
CPU311, CPU331	IC693CMM311 ^{*1 *2}	RS-232C (Cable Diagram 1)	GP series

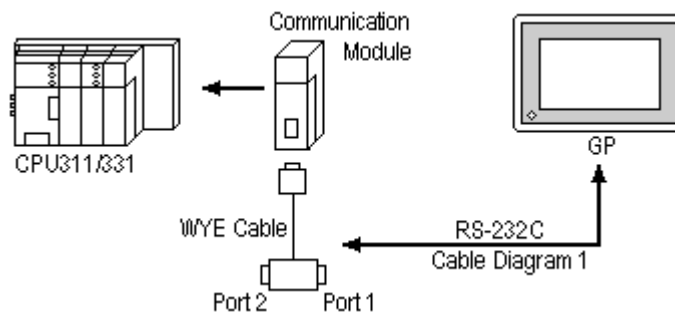

* 1 When using the SIO module (IC693CMM311), the PLC's WYE cable is necessary.



Connect to Port 1 or Port 2. However, when connected to Port 2, switch to RS-232C in the programming console. Both Port 1 and Port 2 can be connected at the same time to two GPs.

* 2 Select SNP-X protocol using the programming console.

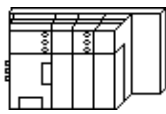

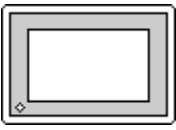
■ Series 90-30 (SNP-X Protocol/CPU Direct Connection)

CPU	Cable Diagram	GP
		
CPU311, CPU331	RS-422 (Cable Diagram 2)	GP series

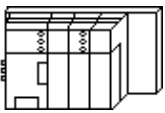

Communication speed is faster than when using the SIO module, however, you cannot use the programming console and the GP at the same time.

■ Series 90-70 (using SNP-X Protocol/Link I/F)

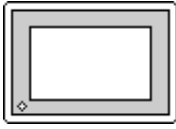
CPU	Link I/F	Cable Diagram	GP
	 SIO Module		
CPU731/732, CPU771/772, CPU781/782	IC697CMM711 ^{*1*2}	RS-232C (Cable Diagram 1) RS-422 (Cable Diagram 3)	GP series



*1 Select SNP-X protocol using the programming console.

*2 Connect to the SIO module's Port 1 or Port 2, and change to RS-232C or RS-422/485 with the programming console. Cannot connect GPs to both Port 1 and Port 2.



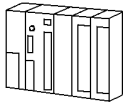

Places noted as RS-422 can also use RS-485 on the PLC side.

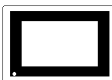
■ Series 90-30 (SNP Protocol, CPU Direct Connection)

CPU	Cable Diagram	GP
		
CPU311 CPU350 CSE311 CPU313 CPU351 CSE313 CPU323 CPU352 CSE323 CPU331 CPU360 CSE331 CPU340 CPU363 CSE340 CPU341 CPU364	RS422 <Cable Diagram 4> RS422 (1:n connection) <Cable Diagram 5>	GP Series units

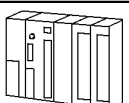
■ Series 90-70 (SNP Protocol, CPU Direct Connection)

CPU	Cable Diagram	GP
		
CPU731 CPU789 CSE924 CPU771 CPM915 CSE925 CPU772 CPM925 CPX772 CPU780 CPX935 CPX782 CPU781 CGR935 CPX928 CPU782 CPM790 CGR772 CPU788 CSE784	RS422 <Cable Diagram 4> RS422 (1:n connection) <Cable Diagram 5>	GP Series units



- Up to 32 PLCs can be connected to one GP.
- Be sure that only one (a single) GP unit is connected to this system.

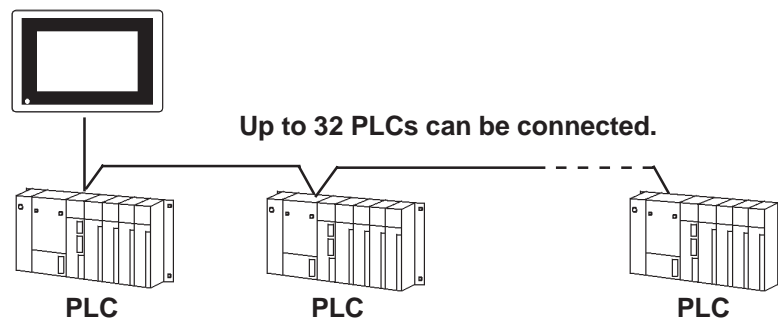

- If multiple PLCs are used, the GP screen's refresh speed may slow when any of the following conditions occur.
 - When a single GP screen is used to monitor many PLCs.
 - When a single GP screen's Part or Tag address settings are not consecutive.

To keep the GP's screen refresh speed as high as possible, the following points are recommended.

- Do not monitor more than three (3) PLCs on one GP screen.
- Try to keep each screen's Part items and Tag address settings consecutive.

2.13.2 Cable Diagrams

The cable diagrams illustrated below and the cable diagrams recommended by GE Fanuc Automation may differ, however, using these cables for your PLC operations will not cause any problems.



- Ground your PLC's FG terminal according to your country's applicable standard. For details, refer to the corresponding PLC manual.



- Connect the FG line of the Shield cable to either the GP or PLC, depending on your environment. When using a connector hood and grounding the FG line, be sure to use an electrical conductor.
- For the RS-232C connection, use a cable length less than 15m.
- Different PLC manuals will write their RS-422 connection drawings (i.e. RD (A), RD (B), SD (A), and SD (B)) differently. Thus, be sure to refer to your specific PLC's manual for this information. The following connection diagrams show examples for connecting a shielded cable to the PLC.
- If a communications cable is used, it must be connected to the SG (signal ground).

Cable Diagram 1 (RS-232C)

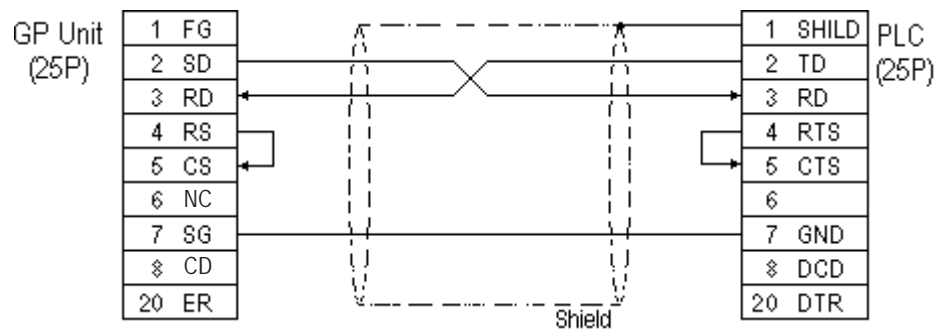

Cable Diagram 2 (RS-422)

- When using Digital's RS-422 connector terminal adapter GP070-CN10-0

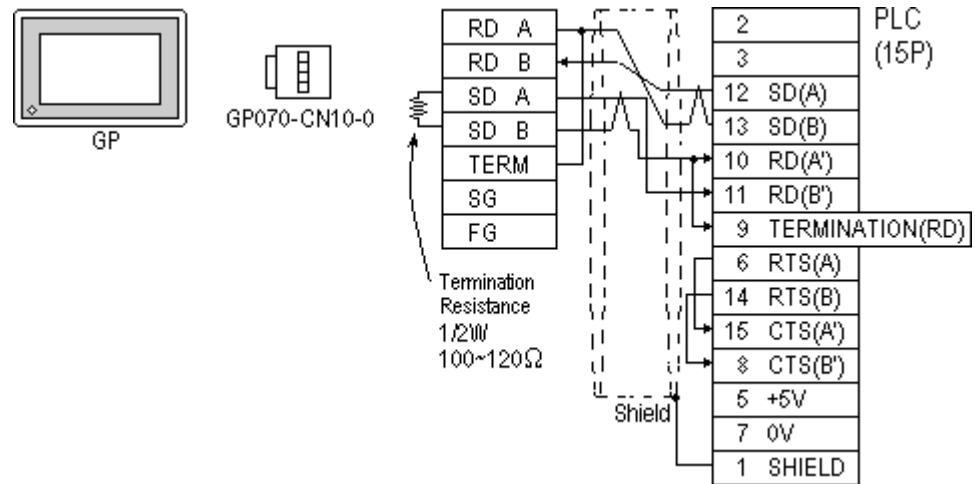

- When using Digital's RS-422 Cable, GP230-IS11-0

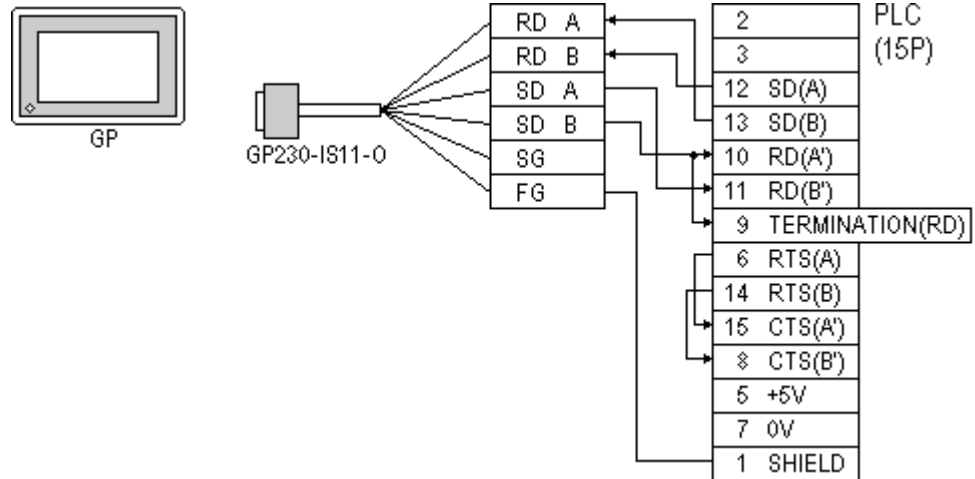

- When making your own cable connections

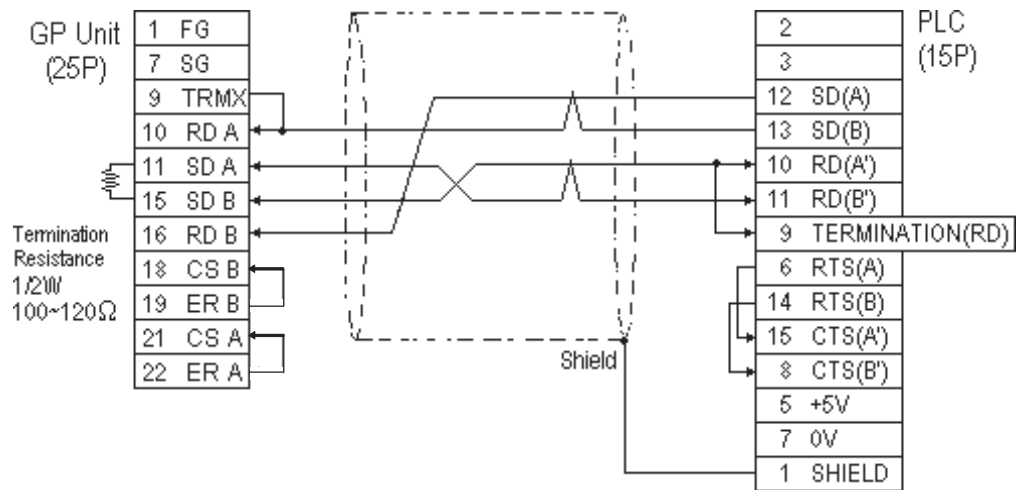



- When making your own connections, we recommend using Hitachi Densen's CO-SPEV-SB(A)3P*0.5 cable.
- When connecting the #9 and #10 pins in the GP Serial I/F, a termination resistance of 100Ω is added between RDA and RDB.
- When using RS-422 connection, please check the cable length with GE Fanuc Automation PLC's users manual.

Cable Diagram 3 (RS-422)

- When using Digital's RS-422 connector terminal adapter GP070-CN10-0

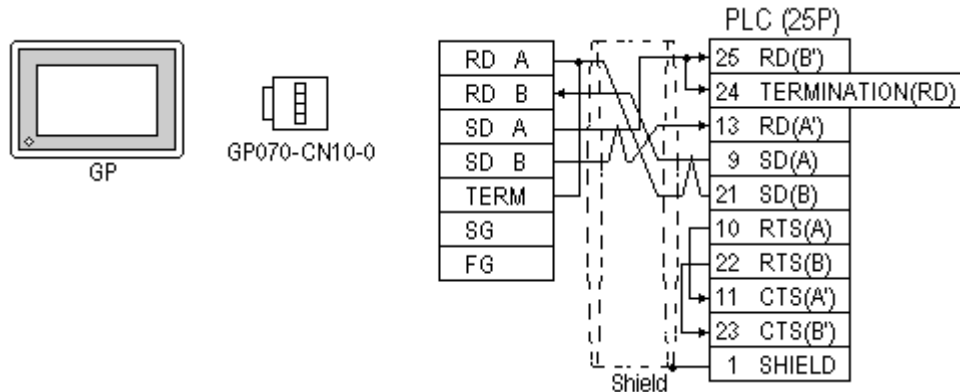

- When using Digital's RS-422 Cable, GP230-IS11-0

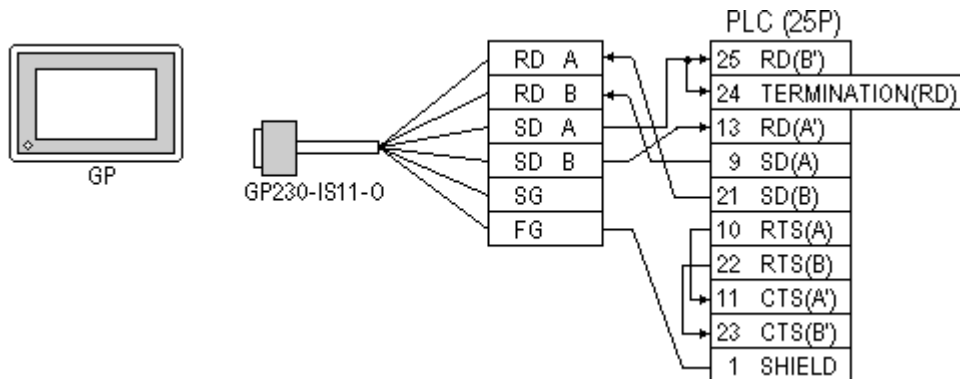

- When making your own cable connections

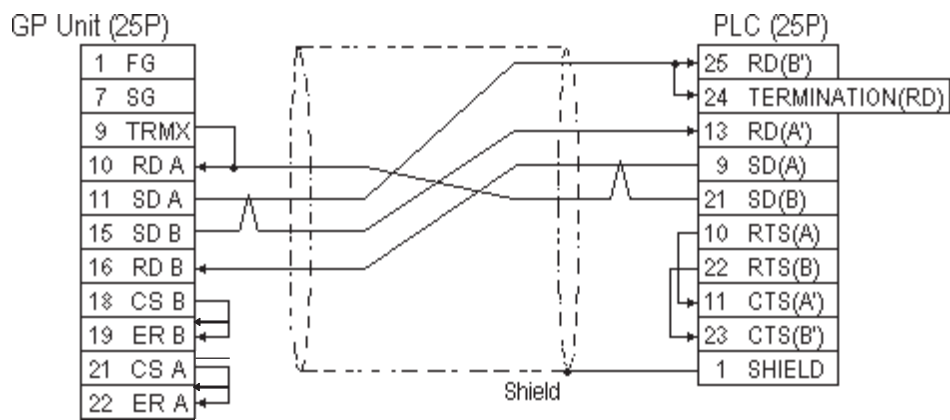

- When connecting the #9 and #10 pins in the GP Serial I/F, a termination resistance of 100Ω is added between RDA and RDB.
- When using RS-422 connection, please check the cable length with GE Fanuc Automation PLC's users manual.

Cable Diagram 4 (1:1) (RS-422)

- When using Digital's RS-422 connector terminal adapter GP070-CN10-0

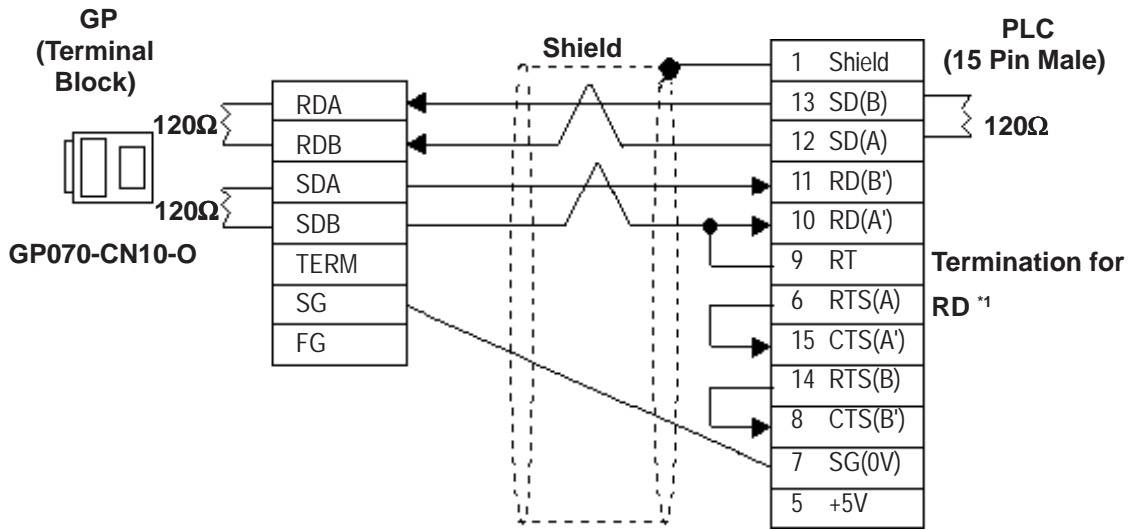

- When making your own cable

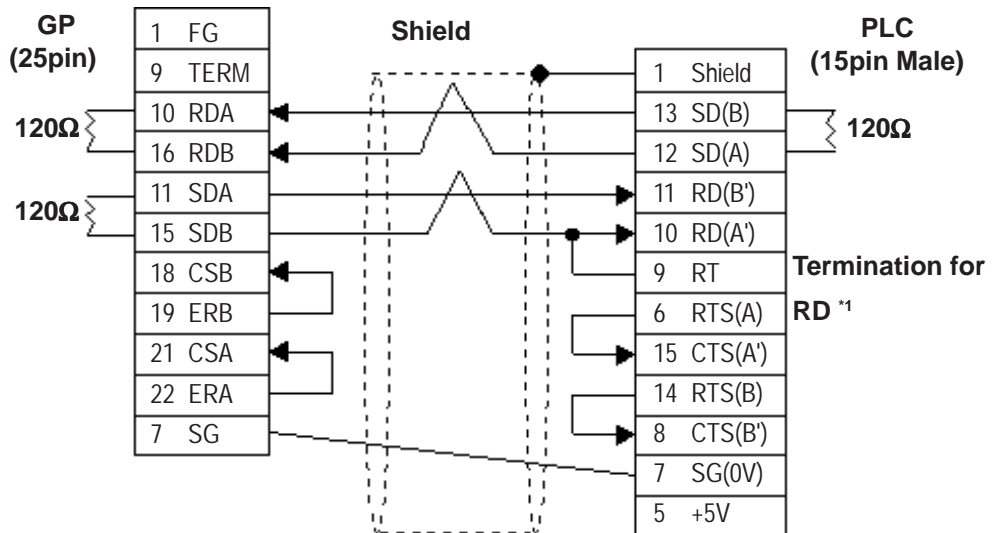

*1 When connecting #9 and #10 pins in the GP Serial I/F, a termination resistance of 120Ω is added between RD-(A') and RD-(B'). When using CPU731 and CPU771, a termination resistance of 120Ω is added between RD-(A') and RD-(B') connecting #9 and #11 pins.



- **Ground your Controller's FG terminal according to your country's applicable standard. For details, refer to the corresponding Controller's manual.**
- **When connecting a cable's Shield line to an FG terminal, consider the needs of your system when deciding which side of the cable (GP or Controller) to connect. (The example below connects to the Controller's FG terminal.)**
- **Be aware the A and B signals of the GP and PLC are opposite to each other.**
- **The cable length must be 600 meters or less.**

2.13.3 Supported Devices

The following tables describe the range of devices supported by the GP.

■ **Series 90-70/90-30 (SNP-X protocol)**

Setup System Area here.

Device	Bit Address	Word Address	Particulars
Input Relay (I)	I0001 ~ I12288	I00001 ~ I12273	÷16+
Output Relay (Q)	Q00001 ~ Q12288	Q0001 ~ Q12273	÷16+
Internal Relay (M)	M00001 ~ M12288	M0001 ~ M12273	÷16+
Global Relay (G)	G0001 ~ G7680	G0001 ~ G7665	÷16+
Momentary Relay (T)	T001 ~ T256	T001 ~ T241	÷16+
System Function Relay (SA)	SA001 ~ SA128	SA001 ~ SA113	÷16+
System Function Relay (SB)	SB001 ~ SB128	SB001 ~ SB113	÷16+
System Function Relay (SC)	SC001 ~ SC128	SC001 ~ SC113	÷16+
System Function Relay (S)	S001 ~ S128	S001 ~ S113	÷16+ *1
Register (R)	---	R00001 ~ R16384	Bit 5
Analog Input (AI)	---	AI0001 ~ AI8192	Bit 5
Analog Output (AQ)	---	AQ0001 ~ AQ8192	Bit 5

L/H

*1 Data cannot be written to this relay. If data is written, a host communication error (02:0F:03) will be displayed.

■ GE Fanuc 90-30/90-70 (SNP protocol)

Setup System Area here.

Device	Bit Address	Word Address	Comments
Input Relay (I)	I00001 ~ I12288	I00001 ~ I12273	Same as word address value divided by 2, then plus 1
Output Relay (Q)	Q00001 ~ Q12288	Q00001 ~ Q12273	Same as word address value divided by 2, then plus 1
Internal Relay (M)	M00001 ~ M12288	M00001 ~ M12273	Same as word address value divided by 2, then plus 1
Global Relay (G)	G0001 ~ G7680	G0001 ~ G7665	Same as word address value divided by 2, then plus 1
Temporary Relay (T)	T001 ~ T256	T001 ~ T241	Same as word address value divided by 2, then plus 1
System Status Relay (SA)	SA001 ~ SA128	SA001 ~ SA113	Same as word address value divided by 2, then plus 1
System Status Relay (SB)	SB001 ~ SB128	SB001 ~ SB113	Same as word address value divided by 2, then plus 1
System Status Relay (SC)	SC001 ~ SC128	SC001 ~ SC113	Same as word address value divided by 2, then plus 1
System Status Relay (S)	S001 ~ S128	S001 ~ S113	Same as word address value divided by 2, then plus 1 ^{*1}
Register (R)	-----	R00001 ~ R01024	Bit 5
	-----	R01025 ~ R02048	
	-----	R02049 ~ R03072	
	-----	R03073 ~ R04096	
	-----	R04097 ~ R05120	
	-----	R05121 ~ R06144	
	-----	R06145 ~ R07168	
	-----	R07169 ~ R08192	
	-----	R08193 ~ R09216	
	-----	R09217 ~ R10240	
	-----	R10241 ~ R11264	
	-----	R11265 ~ R12288	
	-----	R12289 ~ R13312	
	-----	R13313 ~ R14336	
-----	R14337 ~ R15360		
-----	R15361 ~ R16384		
Analog Input (AI)	-----	AI0001 ~ AI1024	Bit 5
	-----	AI1025 ~ AI2048	
	-----	AI2049 ~ AI3072	
	-----	AI3073 ~ AI4096	
	-----	AI4097 ~ AI5120	
	-----	AI5121 ~ AI6144	
	-----	AI6145 ~ AI7168	
-----	AI7169 ~ AI8192		
Analog Output (AQ)	-----	AQ0001 ~ AQ1024	Bit 5
	-----	AQ1025 ~ AQ2048	
	-----	AQ2049 ~ AQ3072	
	-----	AQ3073 ~ AQ4096	
	-----	AQ4097 ~ AQ5120	
	-----	AQ5121 ~ AQ6144	
	-----	AQ6145 ~ AQ7168	
-----	AQ7169 ~ AQ8192		

L/H

*1 Data cannot be written to this device.



- If bit write is performed using the bit designation feature in any of these Bit15 devices, all bits except the designated bit will turn to "0".
- The range of each device's address will vary depending on the CPU type.



- When setting up Tags and Parts in GP-PRO/PBIII for Windows, the PLC CPU ID number can also be designated. If a CPU ID number is not specified, the previously entered CPU ID number is automatically used. (The default value is "01".)

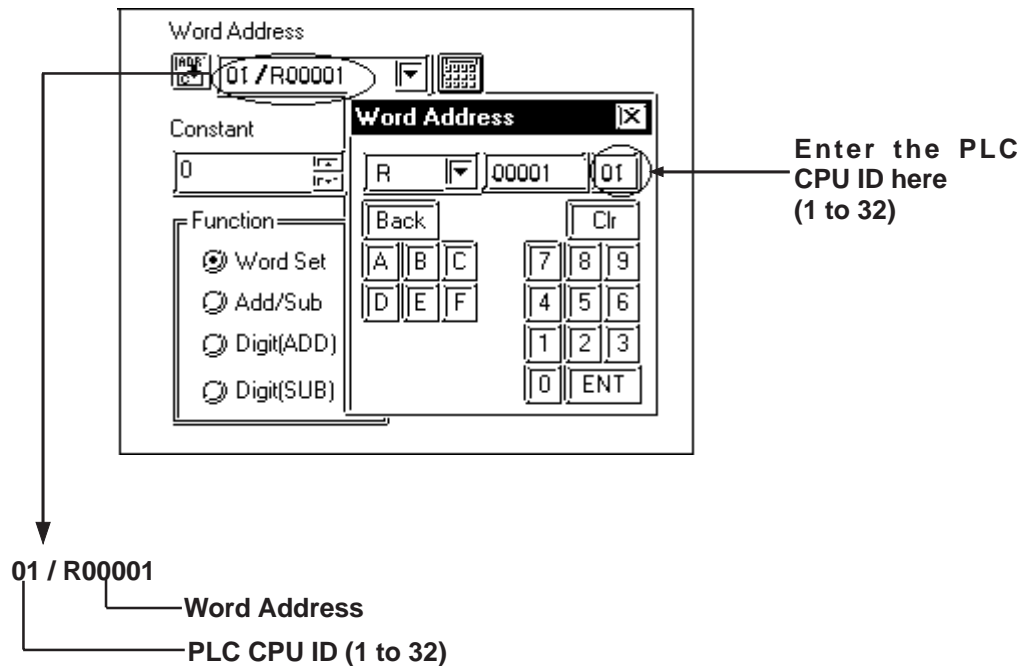

<Driver Usage Restriction>

- When using 1:n connection, the R, AI and AQ devices data areas are each 1024 words on your GP application. You cannot extend over more than one data "block" when performing the following features. Be sure to set these features' settings so they are within one data block.
 - System Area Settings
 - "a-tag " settings
 - Performing Block read/write using the 2-Way feature

Ex) You cannot set a 20 word-data block starting from R1020.
- When setting a PLC's CPU ID, be sure to use a number from "1" to "32" as the CPU ID so that the selected number is used as the PLC's unit number.

2.13.4 Environment Setup

The following tables list Digital's recommended PLC and GP communication settings.

■ **Series 90-30 (SNP-X protocol, using Link I/F)**

GP Setup		SIO Module Setup	
Baud Rate	19200 bps	Baud Rate	19200 bps
Data Length	8 bits (fixed)	Data Bit	8 bits (fixed)
Stop Bit	1 bit	Stop Bit	1 bit
Parity Bit	Odd	Parity Bit	Odd
Data Flow Control	ER Control	---	
Communication Format	RS-232C	Communication Format	RS-232C ^{*1}
---		MODE	SNP ONLY
Unit No.	0 (fixed)	Station Number	0 (fixed)

■ **Series 90-30 (SNP-X protocol, CPU Direct Connection ^{*2})**

GP Setup		Communication Module Setup	
Baud Rate	19200 bps	Baud Rate	19200 bps
Data Length	8 bits (fixed)	Data Bit	8 bits (fixed)
Stop Bit	1 bit	Stop Bit	1 bit
Parity Bit	Odd	Parity Bit	Odd
Data Flow Control	ER Control	---	
Communication Format	4-wire type	---	
Unit No.	0 (fixed)	Station Number	0 (fixed)

**1 Only when connecting to Port 2. This setting is not used for Port 1.*

**2 This must be set through either the ladder logic, or from the programming console unit.*

■ Series 90-70 (SNP-X protocol)

GP Setup		Communication Module Setup	
Baud Rate	19200 bps	Baud Rate	19200 bps
Data Length	8 bits (fixed)	Data Bit	8 bits (fixed)
Stop Bit	1 bit	Stop Bit	1 bit
Parity Bit	Odd	Parity Bit	Odd
Data Flow Control	ER Control	---	
Communication Format (RS-232C)	RS-232C	Communication Format (RS-232C)	RS-232C
Communication Format (RS-422)	4-wire type	Communication Format (RS-422)	RS-422/485
---		MODE	SNP ONLY
Unit No.	0 (fixed)	Station Number	0 (fixed)

■ Series 90-30/90-70 (SNP protocol)

GP		PLC	
Transmission speed	19200 bps	Baud Rate	19200 bps
Data Length	8 bits (fixed)	Data Length	8 bits (fixed)
Stop Bit	1 bit	Stop Bit	1 bit
Parity Bit	Odd	Parity Bit	Odd
Data Flow Control	ER)(fixed)	---	---
Communication Format	4-wire type (fixed)	---	---
Unit No.	1	CPU ID *1	1

*1 Setting Method: when setting a PLC's CPU ID, be sure to use a number from "1" to "32" as the CPU ID so that the selected number is used as the PLC's unit number.



2.14 Fanuc Motion Controller

2.14.1 System Structure



The following describes the system structure for connecting the GP to Fanuc Motion Controller PLCs.

Reference The Cable Diagrams mentioned in the following tables are listed in the section titled "2.14.2 Cable Diagrams".



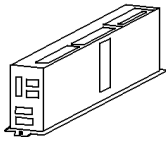

Be sure to inform the Fanuc Corporation clearly that the system will be connected with GP series unit(s).

■ FANUC Power Mate Series

CPU	Cable Diagram	GP
		
Power Mate -MODEL D	RS-422 (Cable Diagram 1)	GP Series

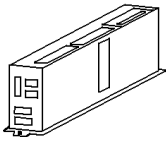
■ FANUC Series

CPU	Cable Diagram	Cables	GP
			
16-MC ^{*1}	RS-232C (Cable Diagram 2)	Digital's GP410-IS00-O(5m)	

**1 When connecting to 16-MC, Fanuc's converting cable A02B-0120-C19 is needed to connect a D-Sub connector (20pins) and a D-Sub connector (25pins).*



The 16-MC unit can be connected only to serial port 2 (JD5B). It cannot be connected to serial port 1 (JD5A).

2.14.2 Cable Diagrams

The cable diagrams illustrated below and the cable diagrams recommended by GE Fanuc Automation may differ, however, using these cables for your PLC operations will not cause any problems.

Cable Diagram 1 (RS-422)



- Connect a Termination Unit to the Motion Controller's JD15. The Termination Unit, with a resistance of 100Ω is connected to the RD B and RD A points.

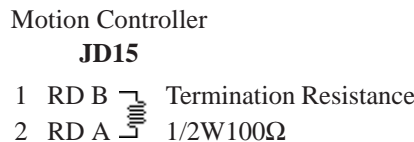

- Ground your Motion Controller Unit's FG terminal. For details, refer to the Motion Controller manual.
- Ground the Shield to the Cable Clamp.
- If a communications cable is used, it must be connected to the SG (signal ground).



When using RS-422 connection, check the cable length with Fanuc Motion Controller PLC's users manual.



- **Recommended Cable:** Oki Densen's A66L-0001-0284#10P
- **Recommended Connector:** Honda Tsushin Kogyo's PCR-E20FS
- **Recommended Connector Case:** Honda Tsushin Kogyo's PCR-V20LA
- **When connecting the #9 and #10 pins in the GP Serial I/F, a termination resistance of 100Ω is added between RDA and RDB.**
- When using Digital's RS-422 connector terminal adapter GP070-CN10-0

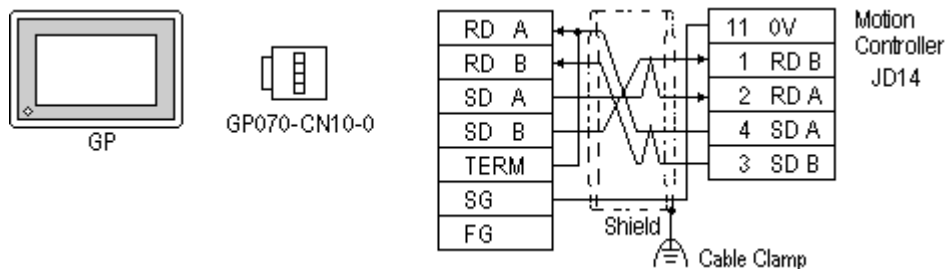

- When using Digital's RS-422 Cable, GP230-IS11-0

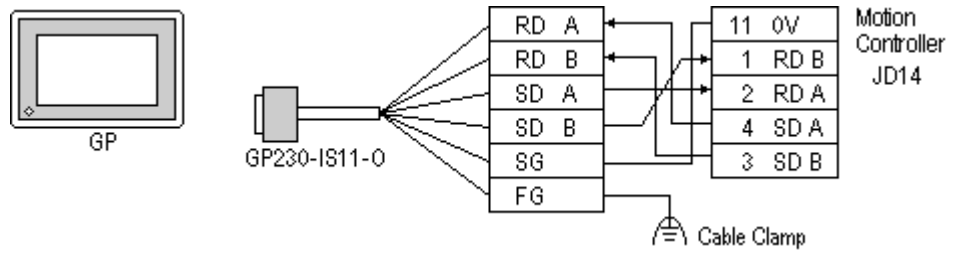

- When making your own cable connections

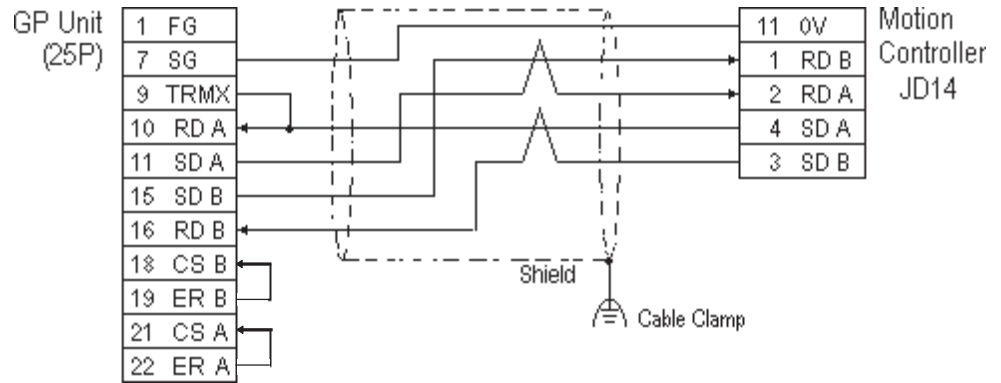



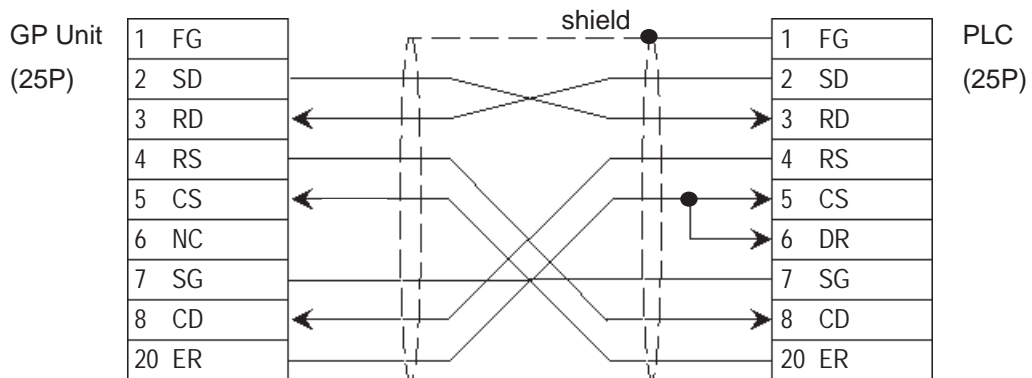





Cable Diagram 2 (RS-232C)



2.14.3 Supported Devices

The following describes the range of devices supported by the GP.

FANUC Power Mate Series Setup System Area here.

Device	Bit Address	Word Address	Particulars
Input Relay (X)	X000000 - X001277 X010000 - X010637	X00000 - X00126 X01000 - X01062	
Output Relay (Y)	Y000000 - Y001277 Y010000 - Y010637	Y00000 - Y00126 Y01000 - Y01062	
Internal Relay (R)	R000000 - R009997	R00000 - R00998	
Keep Relay (K)	K00000 - K00197	K0000 - K0018	
Timer (T)	---	T0000 - T0078	
Counter (C)	---	C0000 - C0078	
Data Table (D)	---	D0000 - D01858	 

L/H

- The address' High/Low relationship is as follows:

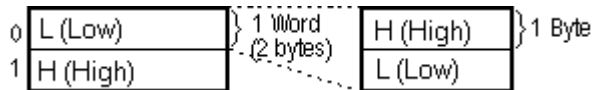

- When entering the *Input Relay, Output Relay, Internal Relay, and Data Table*, enter a 0, after each letter (X,Y,R,D). (The values in the table above already have a 0 added.)

E.g. X0 0120; Y0 01000

- A PLC Communication Error develops when an address outside the range is entered.

E.g. HOST COMMUNICATION ERROR (02 : 0F : * *)

**	Meaning	Solution
04	The entered address does not exist.	Check the range of available Motion Controller addresses, and setup all addresses within this range.
05	The entered data length is incorrect.	

Input Bit Address data using Decimal/Octal.



E.g. **K0063 7**
 Decimal — | — Octal

2.14.4 Environment Setup

The following lists Digital's recommended Motion Controller and GP communication settings.

■ FANUC Power Mate Series

GP Setup		Motion Controller JD14 Setup
Baud Rate	19200 bps (fixed)	---
Data Length	8 bits (fixed)	---
Stop Bit	1 bit (fixed)	---
Parity Bit	Even (fixed)	---
Data Flow Control	ER Control (fixed)	---
Communication Format	4-wire type (fixed)	---
Unit No.	0 (fixed)	---

■ FANUC Series

GP Setup		JD5P Setup
Baud Rate	19200bps(fixed)	-----
Data Length	8bits(fixed)	-----
Stop Bit	1bit(fixed)	-----
Parity Bit	Even(fixed)	-----
Data Flow Control	ER Control (fixed)	-----
Communication Format	RS232C	-----
Unit No.	0 (fixed)	-----





2.15 IDEC

2.15.1 System Structure

The following describes the system structure for connecting the GP to IDEC PLCs.

Reference The Cable Diagrams mentioned in the following tables are listed in the section titled "2.15.2 Cable Diagrams".

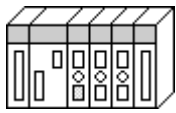
■ FA Series (using Link I/F)

CPU	Link I/F	Cable Diagram	Cables	GP
	 Serial Interface Module			
PF3S-CP12, PF3S-CP13	PF3S-SIF2	RS-232C (Cable Diagram 1)	IDEC Corp.'s PF3S-KS1 *1	GP Series
	PF3S-SIF4	RS-422 (Cable Diagram 2)		

*1 Due to the size of its connector, this cable cannot be used for GP-270, GP-370, GP-377 and GP377R series.



Note:

- After powering up, it takes about 1 second to enter RUN mode when the memory pack capacity of the PF3S-SIF2(4) is 1K step, and it takes about 4 seconds when the memory pack capacity is 4K step. As a result, the GP Start Time setup needs to be set for these situations.

Reference About the GP Start Time setup, refer to each GP Series User Manual, "System Environment Setup"

- Wherever RS-422 appears, RS-485 can be substituted on the PLC.

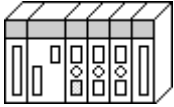
■ FA Series (CPU Direct Connection)

CPU ^{*1}	Adapter ^{*2}	Cable Diagram	Cables	GP
				
PF2-CPU1, PF2-CPU5M, PF2J-CPU1, PF3S-CP11, PF3S-CP12, PF3S-CP13	PF2-CLA PFA-1U51 PFJ-U21	RS-232C (Cable Diagram 3) RS-422 (Cable Diagram 4)	IDECCorp.'s PFA-1A52 shaped computer cable ^{*3}	GP Series

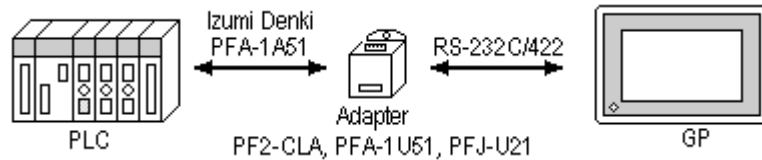

*1 Connect to the programming loader port.

*2 It is necessary to connect the programming loader port and the adapter with Izumi PFA link cable PFA-1A51(30cm). Diagram below

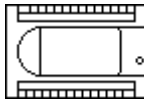

*3 Due to the size of its connector size, this cable cannot be used for GP-270, GP-370, GP-377, GP-377R series.

■ MICRO³ (CPU Direct Connection)

CPU	Adapter	Cable Diagram	Cables	GP
				
MICRO ³	PC I/F Unit FC2A-LC1 ^{*3}	RS-422 (Cable Diagram 5)	PC Link I/F cable ^{*1*2} FC2A-KC1	GP Series

*1 Use Izumi exclusive PC interface cable as the communication cable.

*2 When using the PC I/F cable FC2A-KC1, the GP side becomes RS-232C SIO.

*3 Izumi PC Link I/F cable—FC2A-KC3—is necessary when connecting the PC I/F Unit—FC2A-LC1—and the PLC. Diagram below

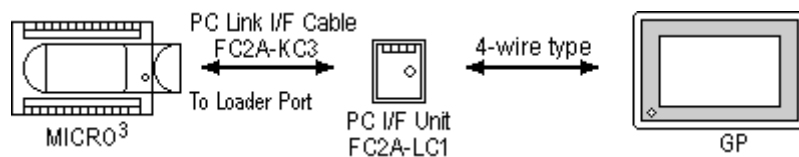

Places noted as RS-422 can also use RS-485 on the PLC side.

2.15.2 Cable Diagrams

The cable diagrams illustrated below and the cable diagrams recommended by IDEC Corp. may differ; however, using these cables for your PLC operations will not cause any problems.



Ground your PLC's FG terminal according to your country's applicable standard. For details, refer to the corresponding PLC manual.



- **Connect the FG line of the Shield cable to either the GP or PLC, depending on your environment settings. When using a connector hood and grounding the FG line, be sure to use an electrical conductor.**
- **If a communications cable is used, it must be connected to the SG (signal ground).**

Cable Diagram 1 (RS-232C)



- **Be sure the RS-232C cable length is 15m or less.**

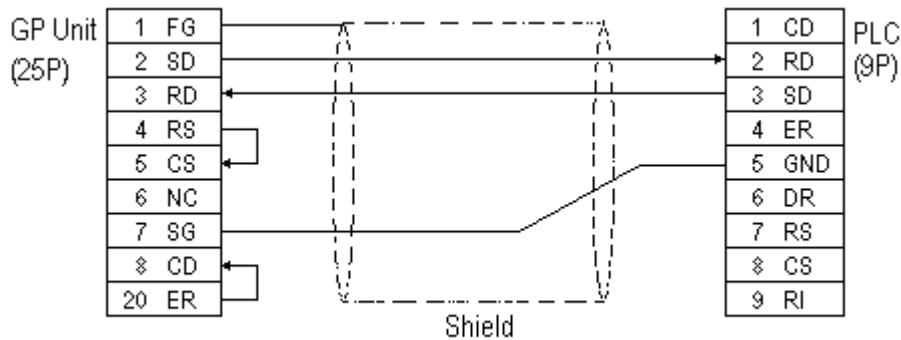

Cable Diagram 2 (RS-422)

- When using Digital's RS-422 connector terminal adapter, GP070-CN10-0

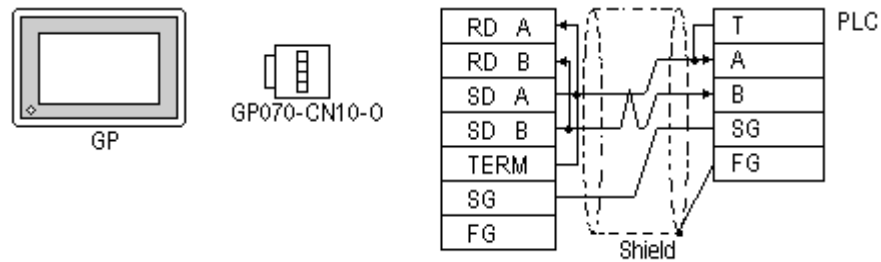

- When using Digital's RS-422 Cable, GP230-IS11-0

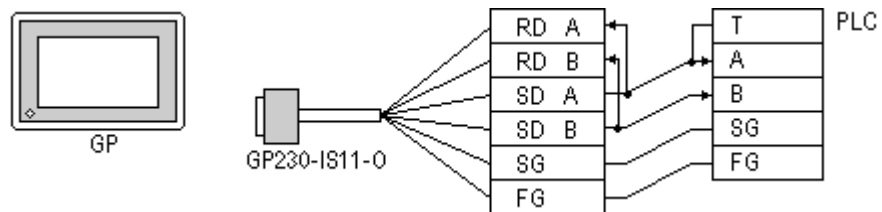

- When making your own cable connections

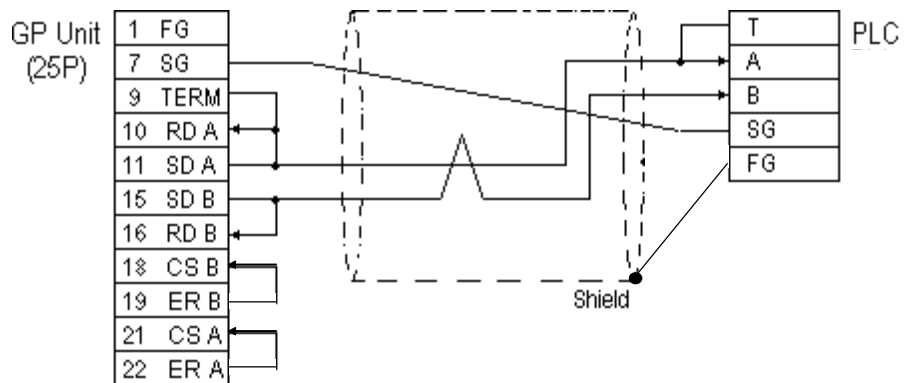

Note:

- When making your own connections, we recommend using Hitachi Densen's CO-SPEV-SB(A)3P*0.5SQ twist pair cable.
- When connecting the #9 and #10 pins in the GP Serial I/E, a termination resistance of 100Ω is added between RDA and RDB.
- For the RS-422 connection, refer to IDEC's PLC manual for the cable length.

Cable Diagram 3 (RS-232C)

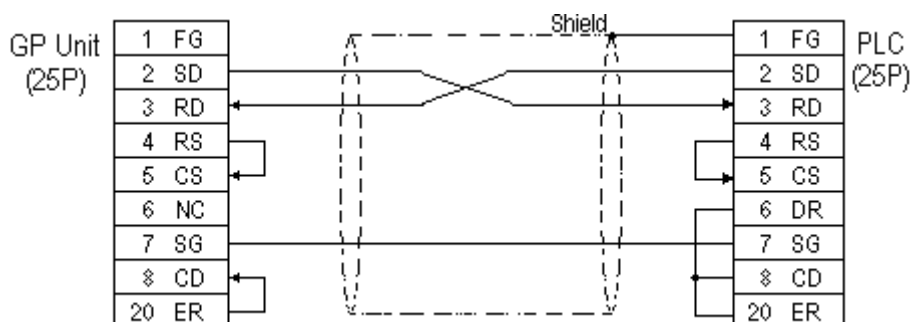

Cable Diagram 4 (RS-422)

- When using Digital's RS-422 connector terminal adapter, GP070-CN10-0

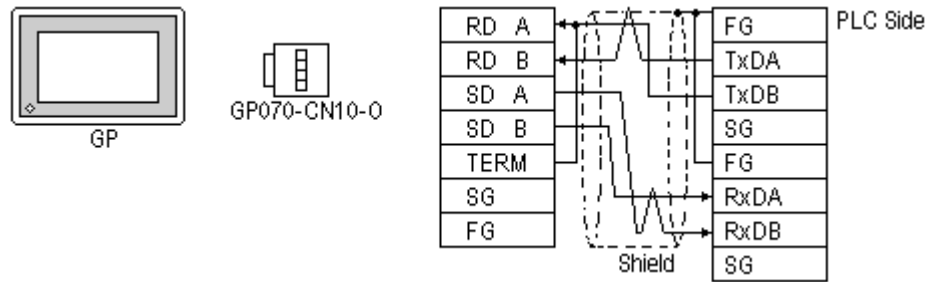

- When using Digital's RS-422 Cable, GP230-IS11-0

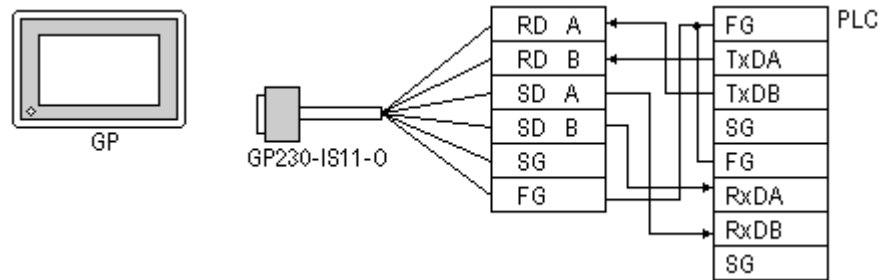

- When making your own cable connections

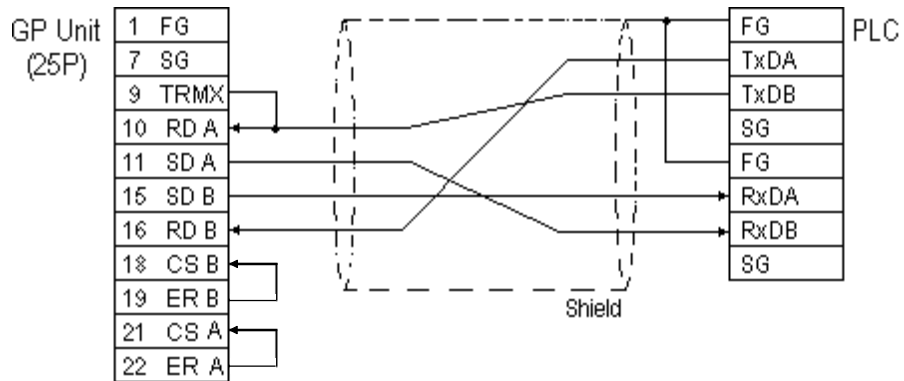

When connecting the #9 and #10 pins in the GP Serial I/F, a termination resistance of 100Ω is added between RDA and RDB.

- For the RS-422 connection, refer to IDEC's PLC manual for the cable length.

Cable Diagram 5 (RS-422)

- When using Digital's RS-422 connector terminal adapter, GP070-CN10-0

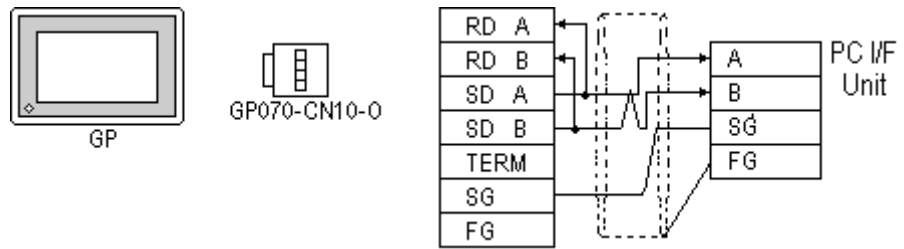

- When using Digital's RS-422 Cable, GP230-IS11-0

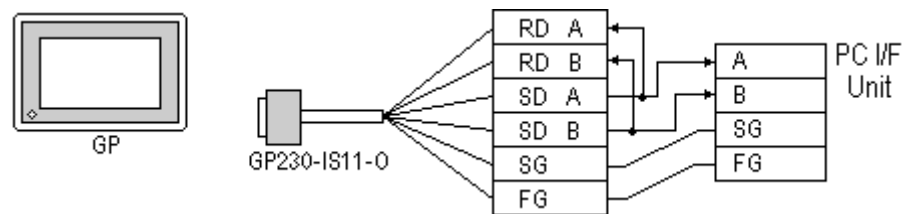

- When making your own cable connections

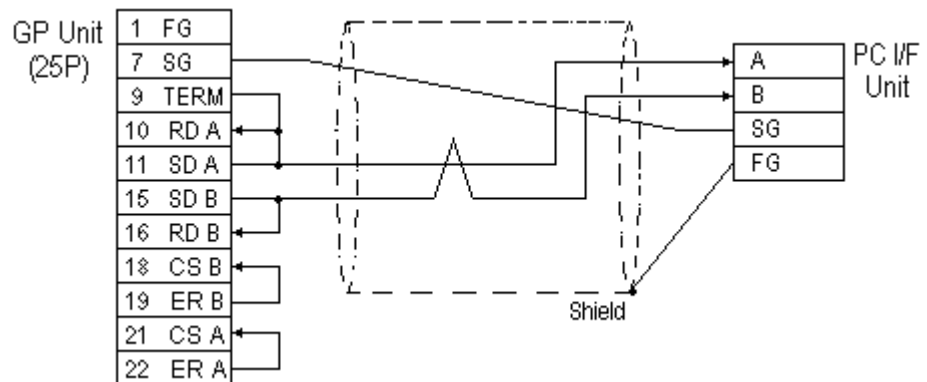

Note:

- When connecting the #9 and #10 pins in the GP Serial I/F, a termination resistance of 100Ω is added between RDA and RDB.
- For the RS-422 connection, refer to IDEC's PLC manual for the cable length.

Cable Diagram 6 (RS-232C)



- For RS-232C communication format, use IDEC Corporation Communication Cable.
- When connecting the cable more than 5m, use RS-422 communication format.

Reference Cable Diagram 8.

- Using IDEC Corporation Communication Cable (model:FC2A-KP1C)>

The GP's Dsub 25-pin connector must be created by the user. Be sure to make your own cable as shown below.

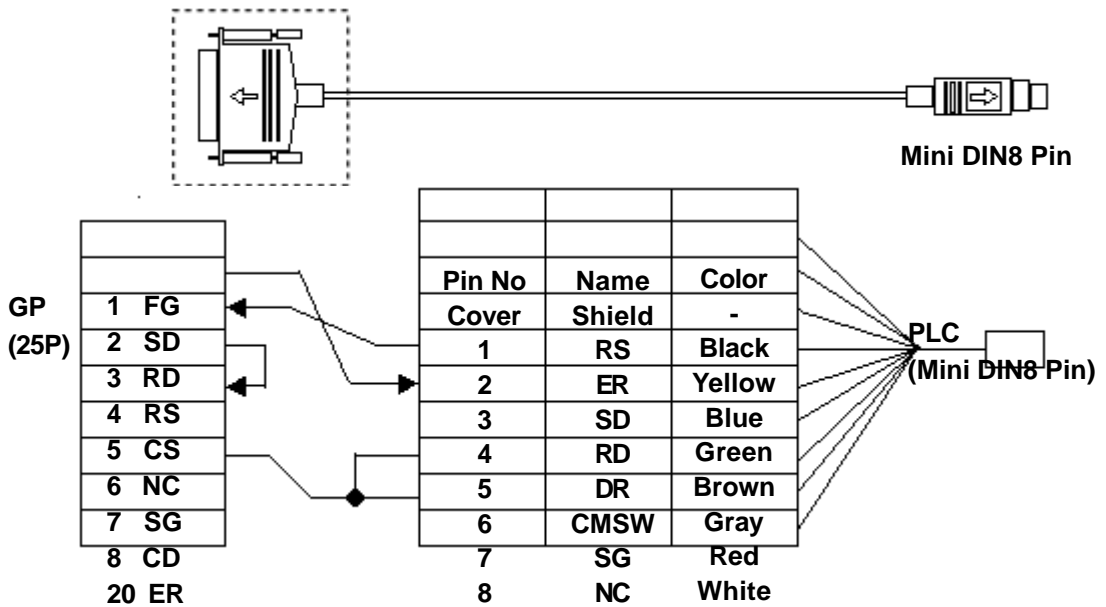

Cable Diagram 7 (RS-232C)



- For RS-232C communication format, use IDEC Corporation Communication Cable.
- When connecting the cable more than 5m, use RS-422 communication format.

Reference Cable Diagram 8 for MICROSmart FC4A Series, or Cable Diagram 10 for OpenNet Controller FC3 Series.

- Using IDEC Corporation Communication Cable (model:FC2A-KP1C)

The GP's Dsub 25-pin connector must be created by the user. Be sure to make your own cable as shown below.

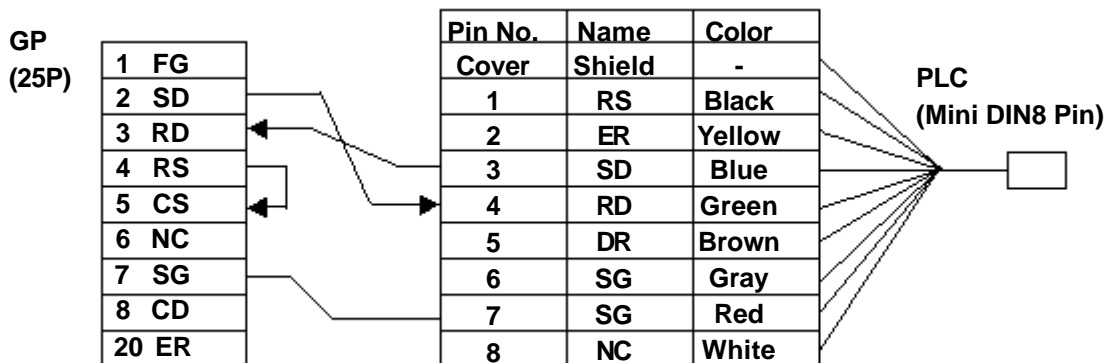

Cable Diagram 8 (RS-422, 2-wire type)



- Use the following cable for the MICROSmart RS-485 Communication Board FC4A-PC3 (Terminal type):

Coaxial Twisted pair wire

- All RS-422 cables should be no more than 200 meters long.
- When using RS-422 communication format, be sure not to connect the termination resistance. If you do, the GP will not work properly.
- Using Pro-face RS-422 connector terminal adaptor GP070-CN10-0

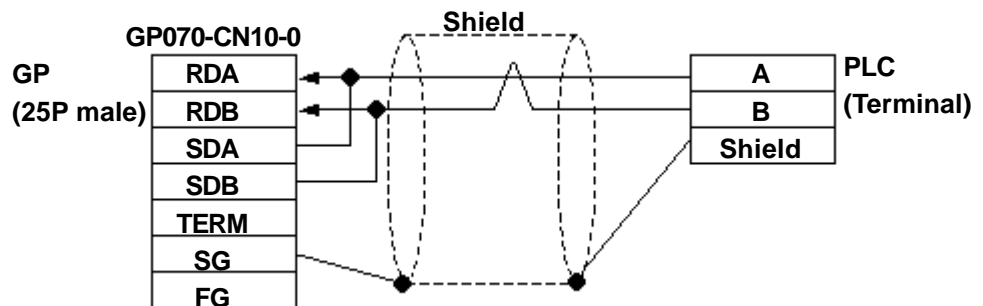

- When making your own cables

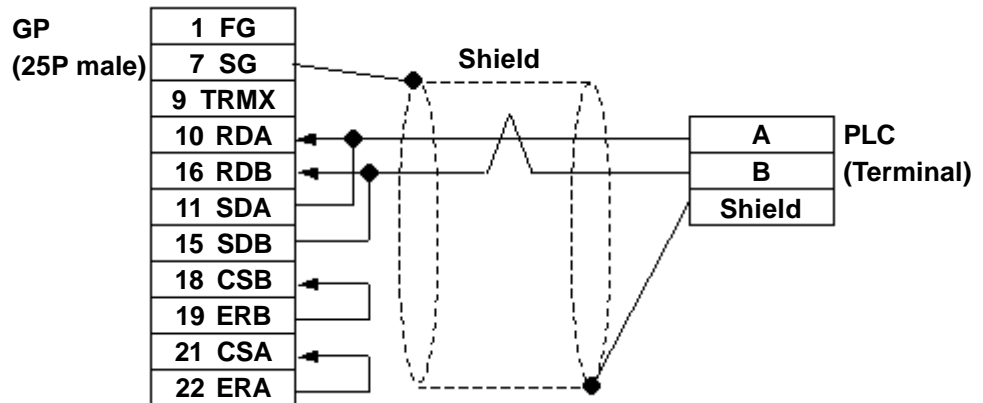

Cable Diagram 9 (RS-422, 2-wire type)



- When using RS-422 communication format, be sure not to connect the termination resistance. If you do, the GP will not work properly.

- Using IDEC Corporation cable HG9Z-XC135

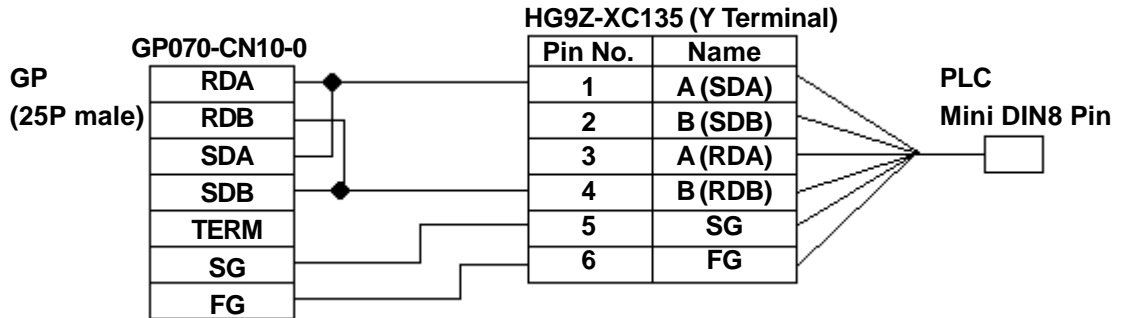

- The PLC side connector's No. 1 and No. 3 pins, and No. 2 and No. 4 pins, respectively, are connected internally.
- Since the HG9Z-XC135 cable's No. 2 and No. 3 terminals cannot be used, be sure to wrap them with insulating tape.

Cable Diagram 10 (RS-422, 2-wire type)



- **Recommended cable for OpenNet Controller RS-485 Port:**
Twisted pair wire with f 0.9 Shield
- **All RS-422 cables should be no more than 200 meters long.**
- **When using RS-422 communication format, be sure not to connect the termination resistance. If you do, the GP will not work properly.**
- Using Pro-face RS-422 connector terminal adaptor GP070-CN10-0

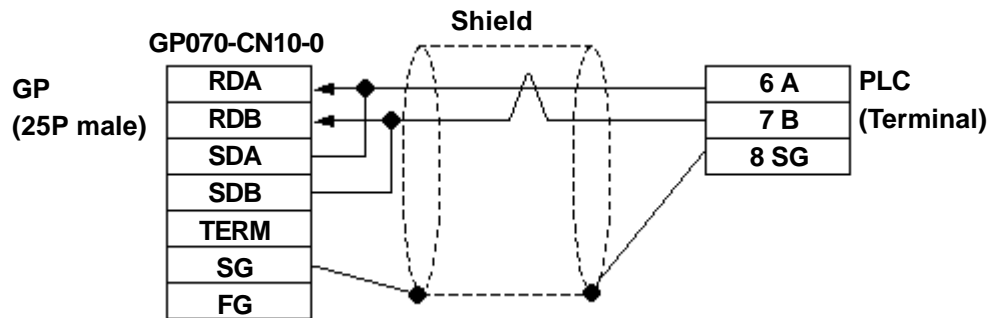

- When making your own cable

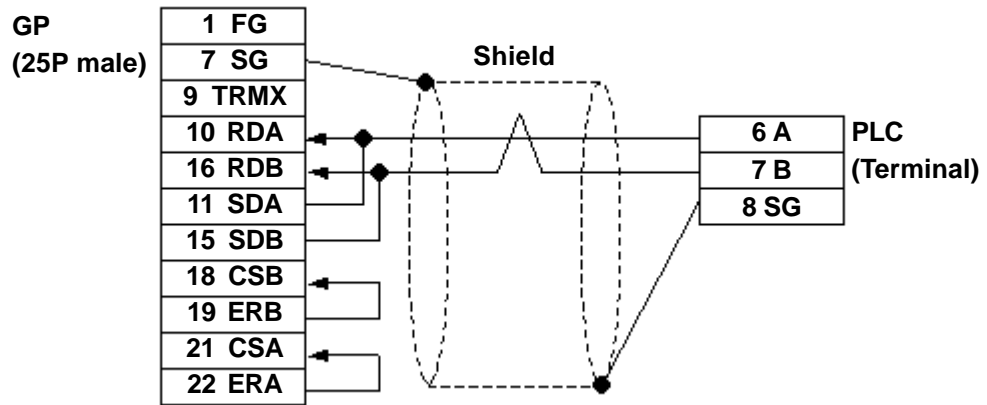

2.15.3 Supported Devices

The following describes the range of devices supported by the GP.

■ FA Series

Setup System Area here.

Device	Bit Address	Word Address	Particulars
Input Relay	X000 ~ X637	WX00 ~ WX63	÷ 2
Output Relay	Y000 ~ Y637	WY000 ~ WY63	÷ 2
Internal Relay	M000 ~ M2557	WM000 ~ WM255	÷ 2
Shift Register	R000 ~ R223	WR000 ~ WR223	÷ 6
Timer (contact)	T000 ~ T255	---	*1
Timer 10msec (contact)	H000 ~ H079	---	*1
Counter (contact)	C000 ~ C255	---	*1
Timer (setup value)	---	TS000 ~ TS255	L/H
Timer (current value)	---	T000 ~ T255	*1
Timer 10msec (current value)	---	H000 ~ H079	*1
Counter (setup value)	---	CS000 ~ CS255	
Counter (current value)	---	C000 ~ C255	*1
Data Register	---	D0000 ~ D2989	Bit 5
Control Register	---	D3000 ~ D3071	Bit 5

*1 Cannot perform data write.







Enter Decimal Octal bit address input for the Input Relay, Output Relay, and the Internal Relay.

E.g. X63 7
└─┬─┘ Octal
└─┬─┘ Decimal

■ MICRO³

 Setup System Area here.

Device	Bit Address	Word Address	Particulars
Input Relay	x00000 ~ x0037	X0000 ~ X0002	
Output Relay	y00000 ~ y0037	Y0000 ~ Y0002	
Internal Relay	m00000 ~ m0277	M0000 ~ M0026	
Shift Register	r0000 ~ r0063	R0000 ~ R0048	
Timer (contact)	T0000 ~ T0031	---	'1'2
Counter (contact)	C0000 ~ C0031	---	'1'2
Timer (setup value)	---	T0000 ~ T0031	'2
Timer (elapsed time)	---	t0000 ~ t0031	'2
Counter (setup value)	---	C0000 ~ C0031	'2
Counter (elapsed value)	---	c0000 ~ c0031	'2
Data Register	---	D0000 ~ D0099	

L/H

*1 Cannot perform data write.

*2 The combined total of timers and counters can be up to 32.



- The Input/Output Relay range depends on the basic unit's Input/Output number.
- The address' High/Low relationship is as follows:

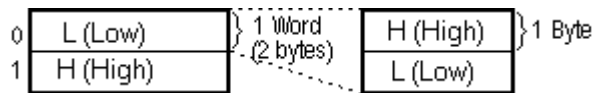

Enter Decimal Octal bit address input for the Input Relay, Output Relay, and the Internal Relay.

E.g. m0002 7
 | |
 | └ Octal
 └ Decimal

■ MICROSmart FC4A Series

 Setup System Area here

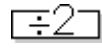
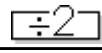
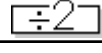
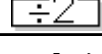
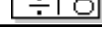
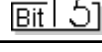
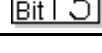
Device	Bit Address	Word Address	Other	
Input	X0000 - X0107	X000 - X010		*1
Output	Y0000 - Y0107	Y000 - Y010		
Internal Relay	M0000 - M1277	M000 - M126		
Special Internal Relay	M8000 - M8157	M800 - M814		
Shift Register	R0000 - R0127	R0000 - R0112		
Timer (contact value)	T0000 - T0099	_____		*1*2
Counter (contact value)	C0000 - C0099	_____		*1*2
Timer (setup value)	_____	T0000 - T0099		
Timer (elapsed value)	_____	t0000 - t0099		
Counter (setup value)	_____	C0000 - C0099		
Counter (elapsed value)	_____	c0000 - c0099		
Data Register	_____	D0000 - D1299		
Special Data Register	_____	D8000 - D8199		
Enter Timer/Counter setup value	_____	Q0 ^{*3}		—









*1 Data Write is not possible.

*2 When writing to this device, the “Host Communication Error (02:FB)” will appear.

*3 Q0 is a virtual device. This is the only device used to write Timer/Counter setup values to Non-volatile Memory. When data is written to this address, new Timer/Counter setup values are written to Non-volatile Memory. To prevent accidental deletion of data due to RAM Backup Battery recharge failure, be sure to write your data to Non-volatile Memory. However, when Non-volatile Memory is written to, the Ladder program’s scan time is delayed. Be sure not to write to this device every time the Timer/Counter setup value is changed. Also, data cannot be read out from this device.

■ OpenNet Controller FC3 Series

Setup System Area here

Device	Bit Address	Word Address	Other
Input	X0000 ~ X0597	X000 ~ X058	 *1
Output	Y0000 ~ Y0597	Y000 ~ Y058	
Internal Relay	M0000 ~ M2557	M000 ~ M254	
Special Internal Relay	M8000 ~ M8237	M800 ~ M822	
Shift Register	R0000 ~ R0255	R0000 ~ R0240	
Timer (contact value)	T0000 ~ T0255	—————	*1 *2
Counter (contact value)	C0000 ~ C0255	—————	*1 *2
Timer (setup value)	—————	T0000 ~ T0255	
Timer (elapsed value)	—————	t0000 ~ t0255	
Counter (setup value)	—————	C0000 ~ C0255	
Counter (elapsed value)	—————	c0000 ~ c0255	
Data Register	—————	D0000 ~ D7999	 L/H
Special Data Register	—————	D8000 ~ D8999	
Link Register	—————	L0100 ~ L1317	 *3

*1 Data Write is not possible.

*2 When writing to this device, the “Host Communication Error (02:FB)” will appear.

*2 **Link Register Device Restrictions**

In GP-PRO/PBIII for Windows, even though from 0 to 9 (Decimal) can be entered as the last digit of a word address, only 0 to 7 can be entered for a PLC address.

Also, even though addresses L0728 to L0999 can be entered, this range does not exist on the PLC, and therefore cannot be used.

Additionally, when entering tag settings, any of the following conditions may occur.

A) During Data Read

When a non-existing address is designated for a Tag, or when Read Out is performed from an area that includes a non-existing address, a Host Communication Error (02:06) will appear on the GP.

Ex) When an N-tag’s word address is designated as L0108.

Or, when an S-tag’s word address is designated as L0100, and the number of display characters is set to 20.

B) During Data Write

When a non-existing address is designated for a Tag, or when Block Write is performed for a block that exceeds 40 words, a Host Communication Error (02:06) will appear on the GP.

Ex) When an N-tag's word address is designated as L0108.

Or, when using the D-Script Memory Copy function, if the Word Address starts from L0100 and 41 copies are designated.

C) Using the Tag Multiple Copy Feature

When creating multiple copies of a Tag, after the copying is finished, be sure to check that all the Tag addresses created can actually be used.

Ex) When an L-Tag's initial word address is designated as L0100 and the copy setting is 10, addresses L0100 to L0109 will be used. In this case, L0108 and L0109 will be out of the available (Base 8) range.

Reference

For the available range of Link Register Addresses and detailed information, refer to the IDEC Corporation's "OpenNet Controller FC3 Series Instruction Manual".

2.15.4 Environment Setup

The following tables list Digital's recommended PLC and GP communication settings.

■ FA Series (using Serial Interface Module)

GP Setup		Serial Interface Module Setup	
Baud Rate	19200 bps	Baud Rate	19200 bps
Data Length	8 bits	Data Bit	8 bits
Stop Bit	1 bit	Stop Bit	1 bit
Parity Bit	Even	Parity Bit	Even
Data Flow Control	ER Control		---
Communication Format (RS-232C)	RS-232C		---
Communication Format (RS-422)	2-wire type		---
Unit No.	0	Device Number	0

■ FA Series (CPU Direct Connection)

GP Setup		PLC Setup	
Baud Rate	9600 bps	Baud Rate	9600 bps
Data Length	8 bits	Data Bit	8 bits
Stop Bit	1 bit	Stop Bit	1 bit
Parity Bit	Even	Parity Bit	Even
Data Flow Control	ER Control		---
Communication Format (RS-232C)	RS-232C		---
Communication Format (RS-2422)	4-wire type		---
Unit No.	0	Device Number	0

■ MICRO³

GP Setup		Loader Port Setup	
Baud Rate	9600 bps	Baud Rate	9600 bps
Data Length	7 bits	Data Bit	7 bits
Stop Bit	1 bit	Stop Bit	1 bit
Parity Bit	Even	Parity Bit	Even
Data Flow Control	ER Control	---	
Communication Format (when using PC I/F Unit FC2A-KC1)	RS-232C	---	
Communication Format (RS-422)	2-wire type	---	
Unit No.	0	Device Number	0



The PLC setup above is the same as the Basic setup mode. When connected to the GP or Loader, communication is available in Basic setup mode (condition when the Mode Change Input Number terminal is OFF). To change the communication setup, use Option setup mode (condition when the Mode Change Input Number terminal is ON).

■ MICROSmart FC4A Series

GP/GLC Settings		PLC Settings	
Baud Rate	9600 bps	Baud Rate	9600 bps
Data Length	7 bits	Data Length	7 bits
Stop Bit	1 bit	Stop Bit	1 bit
Parity Bit	Even	Parity Bit	Even
Data Flow Control	ER Control	---	---
Communication Format (RS-232C)	RS-232C	---	---
Communication Format (RS-485)	2-wire type	---	---
Unit No.	0	Device No.	0
---	---	Port Communication Type	Maintenance Communication
---	---	Communication Switchover Input	No

■ OpenNet Controller FC3 Series

GP/GLC Settings		PLC Settings	
Baud Rate	9600 bps	Baud Rate	9600 bps
Data Length	7 bits	Data Length	7 bits
Stop Bit	1 bit	Stop Bit	1 bit
Parity Bit	Even	Parity Bit	Even
Data Flow Control	ER Control		---
Communication Format (RS-232C)	RS-232C		---
Communication Format (RS-485)	2-wire type		---
Unit No.	0	Device No. DIP-SW4 ~ 8	0
		RS-485 Communication Mode DIP-SW1	OFF (Maintenance)
		RS-232C Port 1 Communication Mode DIP-SW2	OFF (Maintenance)
		RS-232C Port 2 Communication Mode DIP-SW3	OFF (Maintenance)
		Communication Switchover Input	No

◆Monitor Register

When using OpenNet Controller FC3 Series, the Monitor Register feature can be set. Using this function, Block reads of discrete addresses (maximum of 40 words) can be made. This function can also be used, when using the Multi Port Communication or connecting your PC. Be sure to set the Monitor Register feature from the SETUP OPERATION SURROUNDINGS MENU in the GP OFFLINE mode or from [GP SETUP] -> [MODE SETTINGS] in the GP Screen Editor (GP-PRO/PBIII for Windows).

Reference Refer to each GP User Manual, OFFLINE MODE.



- **The Monitor Register feature cannot be used on MICROsmart FC4A Series. Be sure to set the Monitor Register setting to “No”. If the MONITOR SETTING feature is set to “Yes”, a "Host Communication Error (02:03)" will appear.**

Reference Refer to this manual, 2.15.4 Error Codes.

- **Default setting is “No”.**
- **Depending on whether you are using a GP or a GLC series unit, the OFFLINE mode's SETUP OPERATION SURROUNDING MENU, the menu that appears may differ. Setup the Monitor Register area as shown below.**

<GPH70 Series, GP-270 Series, GP-370 Series, GLC100 Series>

SET UP OPERATION SURROUNDINGS	SET	ESC
SYSTEM AREA START DEV	<input type="text"/>	
START ADR	<input type="text"/>	
UNIT No.	<input type="text"/>	
SYSTEM AREA READ SIZE	<input type="text"/>	
MONITOR REGISTER	<input type="text"/>	

<GP-470 Series, GP-570 Series, GP-675 Series, GP-870 Series>

SET UP OPERATION SURROUNDINGS			
STARTING ADDRESS OF SYSTEM DATA AREA	[]
UNIT NO.	[]
SYSTEM AREA READING AREA SIZE (0-256)	[]
MONITOR REGISTER	ON	OFF	

<GP-377 Series, GP-377R Series>

Set the Monitor Register feature from the SETUP OPERATION SURROUNDINGS MENU [PLC SETUP MENU] -> [PLC SETUP 2] in the GP OFFLINE mode.

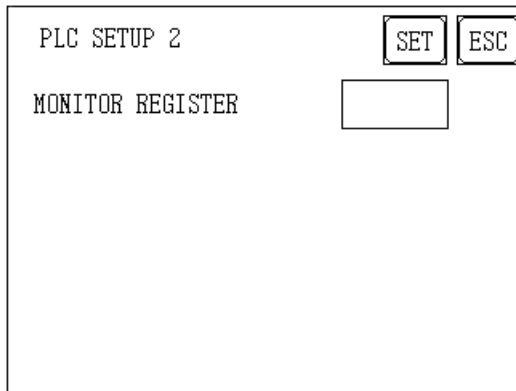
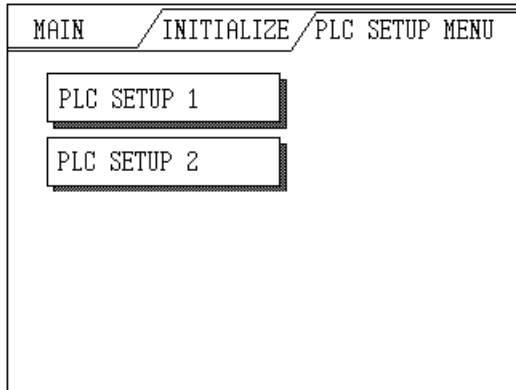

<GP-477R Series, GP-577R Series, GP2000 Series, GLC300 Series, GLC2000 Series>

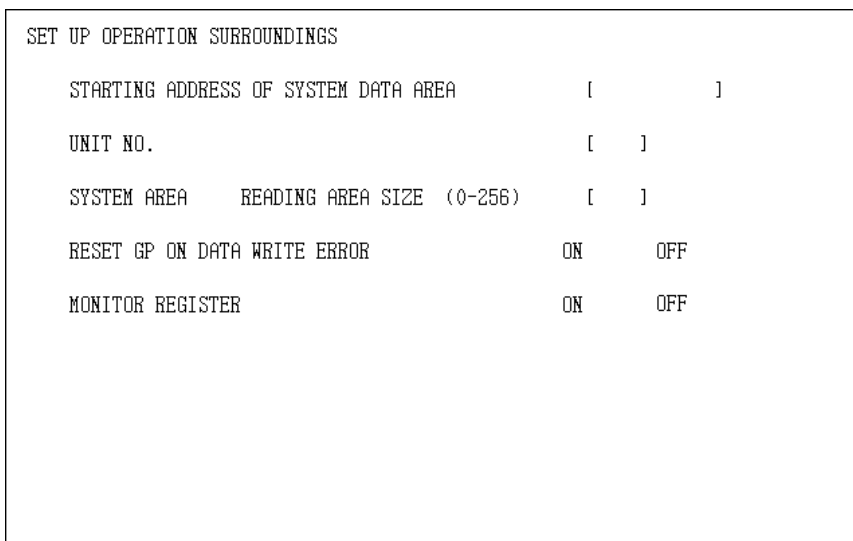

- **Setting Monitor Register from the GP Screen Editor (GP-PRO/PBIII for Windows)**

Set the Monitor Register feature from [GP SETUP] -> [MODE SETTINGS] in the GP Screen Editor (GP-PRO/PBIII for Windows). This feature's default setting is "not selected".

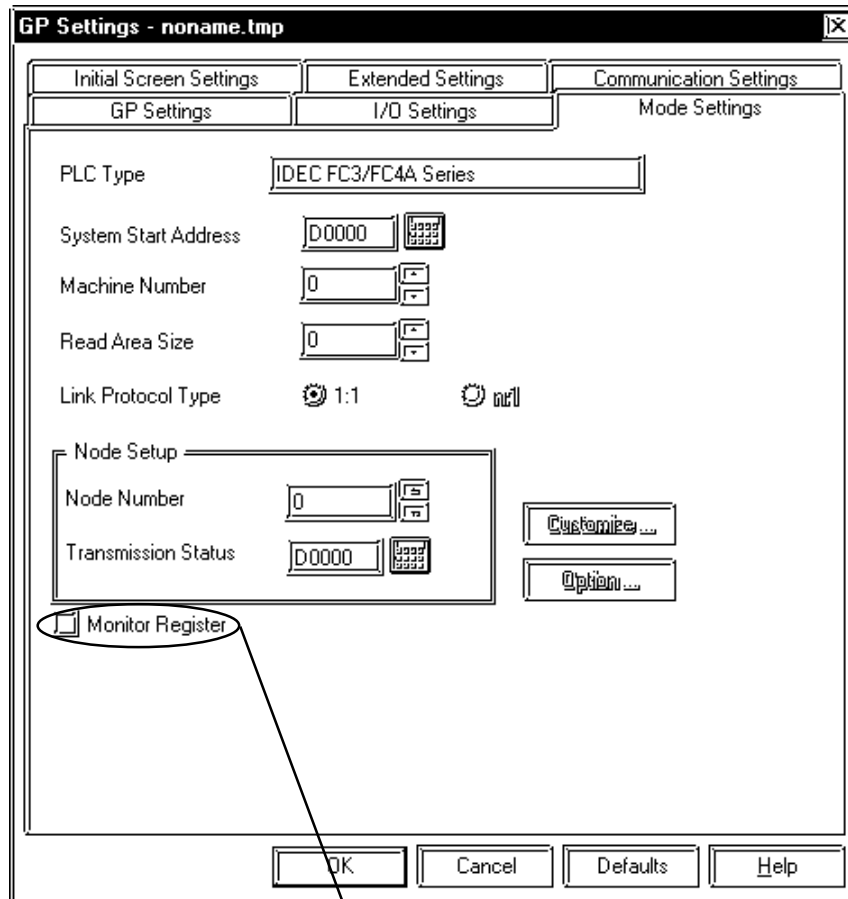

Click this radio box to set the Monitor Register.

2.15.5 Error Codes

■ PLC Specific Error Codes

◆ MICROSmart FC4A Series/OpenNet Controller FC3 Series

IDEC Corporation PLCs have two types of error codes, “Communication Error Code” and “NG Code”. A “Communication Error” means the error occurred during transmission. “NG Error” means the error occurred after receiving the message from the PLC. “NG Code” is the error code for standard GP/GLC units. “Communication Error Code” and “NG Error Code” are displayed via the “Host Communication Error (02:**)”, and will appear in the left lower corner of the GP/GLC screen (** indicates the PLC’s error code).

• Communication Error Code

Error Code	Error Type	Error Contents
00	BCC error	Appended BCC code does not match BCC calculated value of received data.
01	Flame error	Quantity of received bits differs from the preset value (stop bit is 0 for example).
02	Data send/receive error	Parity Error or Overrun error occurred.
03	Command error	Unsupported request message is received.
04	Procedure/data quantity error	Received request message does not match the expected data (including quantity of data).

• NG Code

Error Code	Error Name	Meanings
06	Data range error	Invalid data range designated.
07	Timer/Counter preset value change error	Preset value change attempted to timer or counter with preset value designated by data register.
10	Data error	Invalid data other than 0 (30h) - 9 (39h) or A (41h) - F(46h).
11	Setting error	Incorrect setting for user communication.

▼ Reference ▲

For more details about error codes, refer to the IDEC Corporation’s “COMPUTER LINK SYSTEM USER’S MANUAL”.





2.16 Siemens

2.16.1 System Structure

The following describes the system structure for connecting the GP to Siemens PLCs.

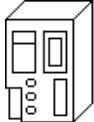
Reference The Cable Diagrams mentioned in the following tables are listed in the section titled "2.16.2 Cable Diagrams".

■ SIMATIC S5 Series (using Link I/F <3964/3964R via RK512 Protocol>)



CPU	Link I/F	Cable Diagram	GP
			
90U, 95U, 100U	CP521 S1	RS-232C (Cable Diagram 1)	GP Series
115U	CP524 CP525		
115U (CPU944)	CPU unit Link I/F *1		
135U, 155U	CP524 CP525		
135U, 155U (CPU928B)	CPU unit Link I/F *1		

*1 Connect to SI2 Port.



Note: Supports both 3964 and 3964R protocols. The GP automatically discriminates between the two. For better error detection, the 3964R is recommended.

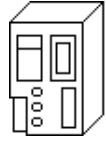

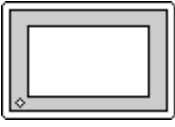
■ **SIMATIC S5 Series (CPU Direct Connection)**

CPU *1	Cables	GP
		
90U, 95U, 100U (CPU100/102/103), 115U (CPU941/942/943/ 944), 135U/155U (CPU922/928/928B)	Digital's current loop converter *2 GP000-IS11-O	GP Series

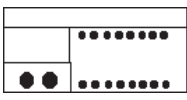

*1 Connect to the Programming port.

*2 Due to the size of its connector size, this cable cannot be used for GP-270, GP-370, and GP-377Rseries.

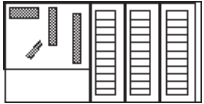

■ **SIMATIC S7-200 Series (CPU Direct Connection)**

CPU	Cables	GP
		
CPU212, CPU214	RS422 (Cable Diagram 2)	GP Series

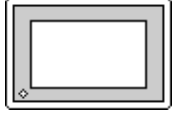
■ **SIMATIC S7-300/400 CPU Direct (via MPI Port) Connection**

CPU	Link I/F	Cable Diagram	GP
			
CPU312IFM, CPU313, CPU314, CPU315, CPU315-2DP, CPU413- 2DP	HMI Adapter 6ES7-972-0CA 10-0XA0	RS-232C (Cable Diagram 3)	GP Series
	PC Adapter 6ES7-972-0CA21-0XA0	RS-232C (Cable Diagram 3)	
	PC/MPI Cable 6ES7901-2BF00-0AA0	RS-232C (Cable Diagram 4)	

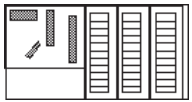
■ SIMATIC S7-300/400 via 3964/RK512 (using Link I/F)

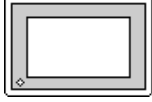
CPU	Link I/F	Cable Diagram	GP
			
CPU313, CPU314, CPU315, CPU315-2DP	CP340 *1 CP341	RS-232C (Cable Diagram 5)	GP Series
CPU413-2DP	CP441-2	RS-422 (Cable Diagram 6)	





This driver cannot be used with the CPU312IFM.

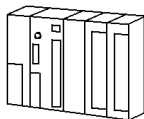

*1 When using the CP340 Link I/F an "Interpreter program" is required on the PLC. This is contained in the GP-PRO/PBIII for Windows Ver.4.0 CD-ROM 's "CP340" folder. Please see "README" file in this folder in order to install this program.

■ SIMATIC 505 Series

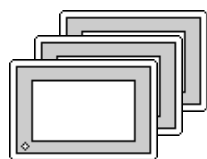
CPU	Cable Diagram	GP
		
SIMATIC 545-1101, SIMATIC 545-1102, SIMATIC 545-1103, SIMATIC 545-1104, SIMATIC 545-1105, SIMATIC 545-1106, SIMATIC 555-1101, SIMATIC 555-1102, SIMATIC 555-1103, SIMATIC 555-1104, SIMATIC 555-1105, SIMATIC 555-1106	RS-232C Port 1 Connection (Cable Diagram 7)	GP Series
SIMATIC 545-1101, SIMATIC 545-1102, SIMATIC 555-1101, SIMATIC 555-1102	RS-422(4-wire type) Port 2 Connection (Cable Diagram 8)	
SIMATIC 545-1104, SIMATIC 545-1105, SIMATIC 545-1106, SIMATIC 555-1103, SIMATIC 555-1104, SIMATIC 555-1105, SIMATIC 555-1106	RS-422(4-wire type) Port 2 Connection (Cable Diagram 9)	
SIMATIC 545-1103, SIMATIC 545-1104, SIMATIC 545-1105, SIMATIC 545-1106, SIMATIC 555-1103, SIMATIC 555-1104, SIMATIC 555-1105, SIMATIC 555-1106	RS-232C Port 2 Connection (Cable Diagram 10)	
SIMATIC 545-1101, SIMATIC 545-1102, SIMATIC 555-1101, SIMATIC 555-1102	RS-232C Port 2 Connection (Cable Diagram 11)	

2.16.2 Cable Diagrams

The cable diagrams illustrated below and the cable diagrams recommended by Siemens may differ, however, using these cables for your PLC operations will not cause any problems.



Ground your PLC's FG terminal according to your country's applicable standard. For details, refer to the corresponding PLC manual.



- **Connect the FG line of the Shield cable to either the GP or PLC, depending on your environment. When using a connector hood and grounding the FG line, be sure to use an electrical conductor. The following connection diagrams show examples for connecting a shielded cable to the PLC.**
- **For the RS-232C connection, use a cable length less than 15m.**
- **For the RS-422 connection, use a cable length less than 500m.**
- **If a communications cable is used, it must be connected to the SG (signal ground).**

Cable Diagram 1 (RS-232C)

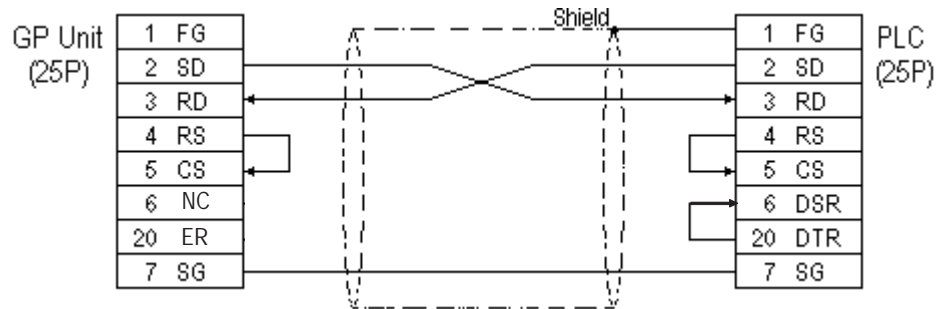

Cable Diagram 2 (RS-422)

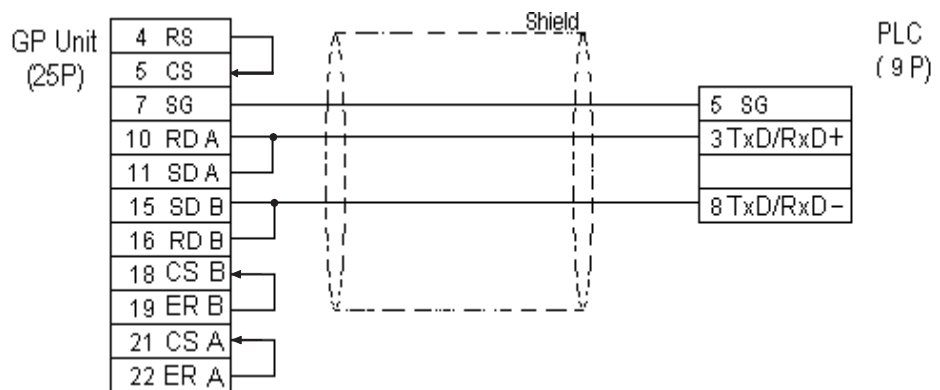

Cable Diagram 3 (RS-232C)

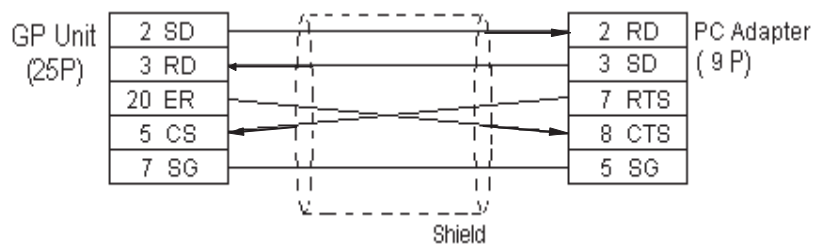

Cable Diagram 4 (RS-232C)

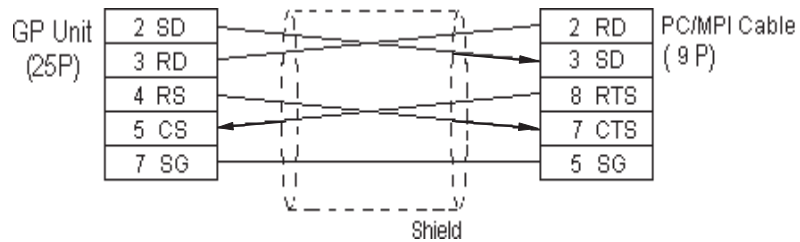

Cable Diagram 5 (RS-232C)

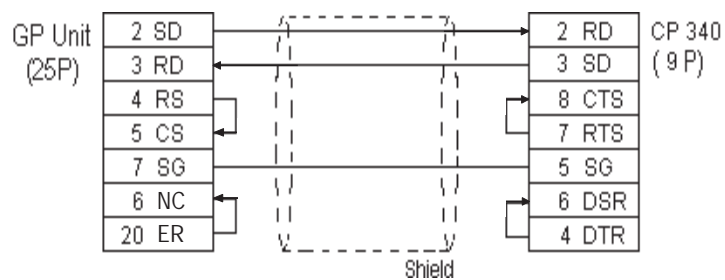

Cable Diagram 6 (RS-422)

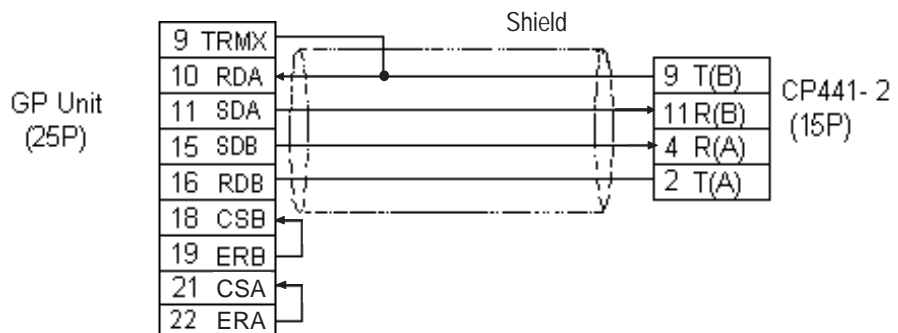

Cable Diagram 7 (RS-232C)

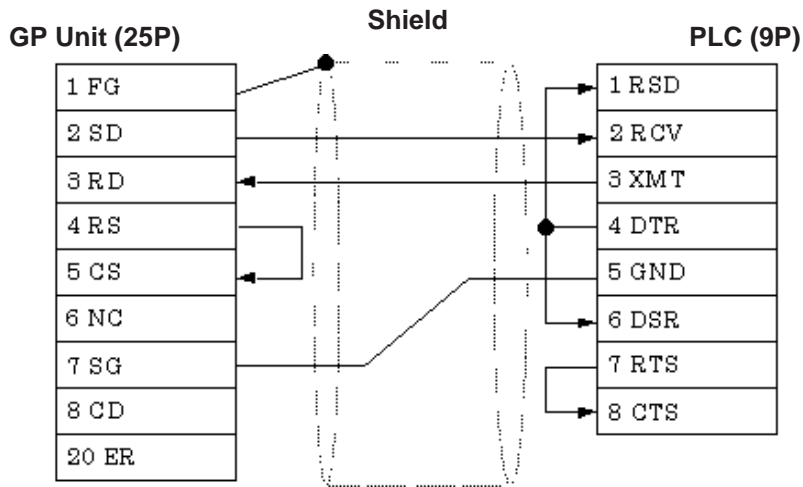

Cable Diagram 8 (RS-422)

- When using Digital's RS-422 connector terminal adapter, GP070-CN10-O

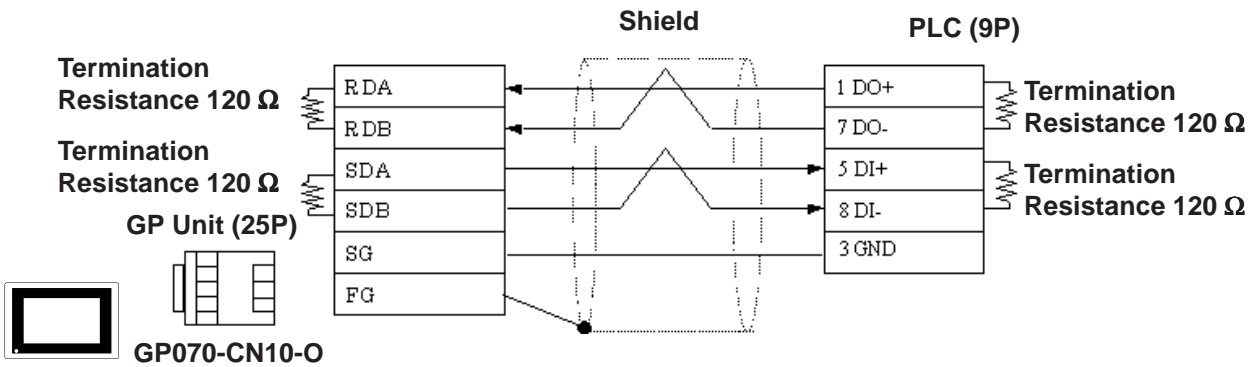

- When making your own cable connections

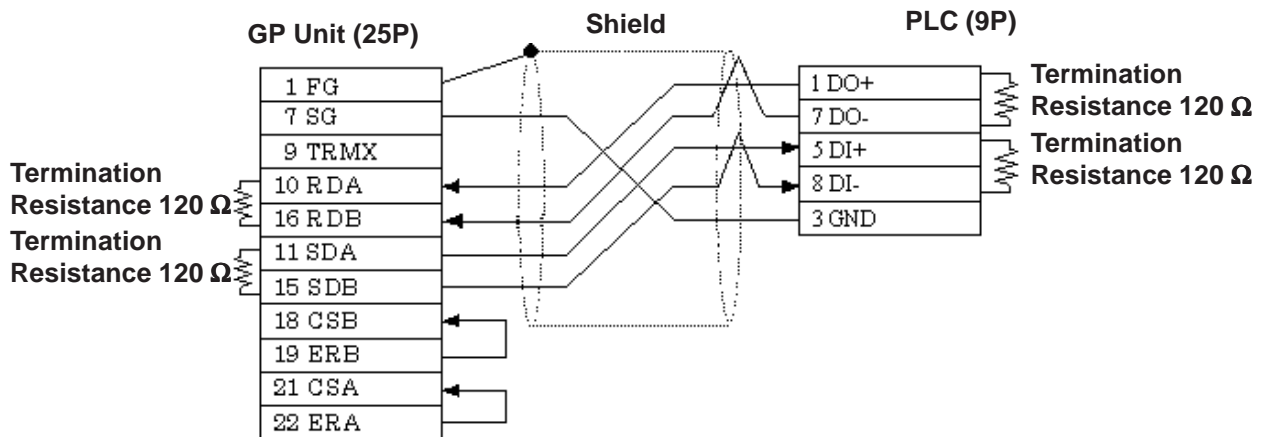

Cable Diagram 9 (RS-422)

- When using Digital's RS-422 connector terminal adapter, GP070-CN10-O

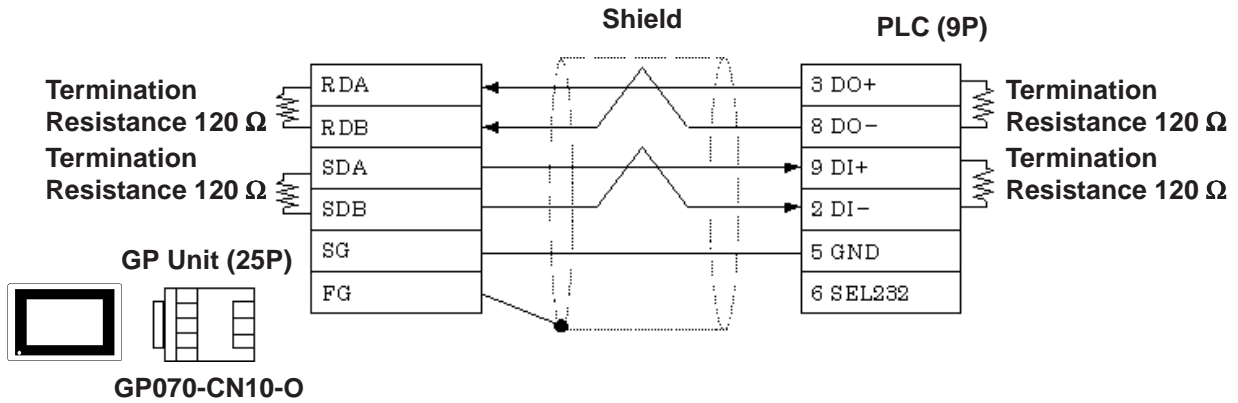

- When making your own cable connections

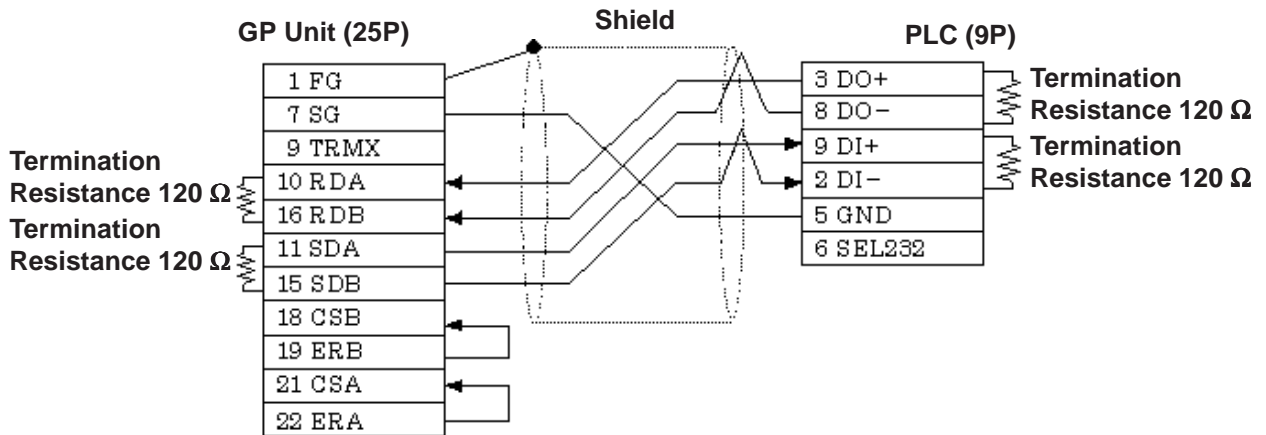

Cable Diagram 10 (RS-232C)

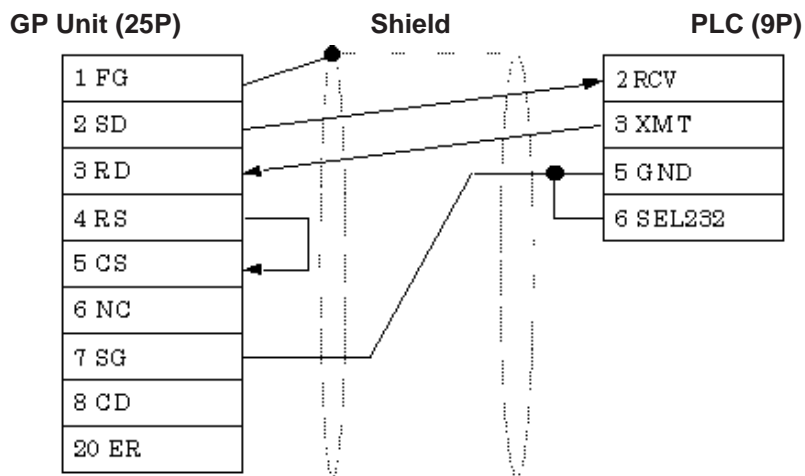

Cable Diagram 11 (RS-232C)

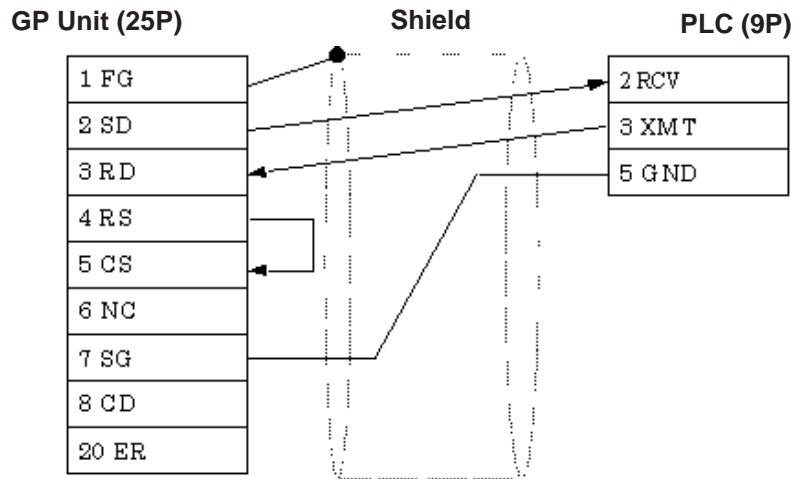



2.16.3 Supported Devices

The following tables describe the range of devices supported by the GP.

■ SIMATIC S5 Series (using Link I/F)





 Setup System Area here.

Device	Bit Address	Word Address	Particulars
Data Register	---	D003000 ~ D255255	 *1*2
Extended Data Register	---	X003000 ~ X255255	 *1*2

H/L

■ SIMATIC S5 Series (CPU Direct Connection)

 Setup System Area here.

Device	Bit Address	Word Address	Particulars
Input Relay	I0000 ~ I1277	IW000 ~ IW126	 *3
Output Relay	Q0000 ~ Q1277	QW000 ~ QW126	 *3
Internal Relay	F0000 ~ F2557	FW000 ~ FW254	 *3
Timer	---	T000 ~ T255	
Counter	---	C000 ~ C255	
Data Register	---	D002000 ~ D255255	 *1*4
Extended Data Register	---	X002000 ~ X255255	 *1*4*5

H/L

* 1 The range for the Data Register and the Extended Data Register must also be set up in the PLC. Communication will not occur with the GP when the System Area range is not setup.

* 2 The Data Register and Extended Data Register is as illustrated below.

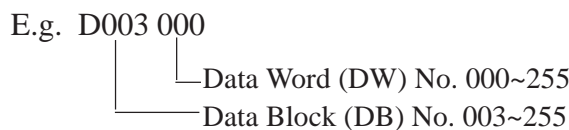

* 3 The bit device illustration for the PLC side is different.

E.g.

GP	PLC
Q0007	Q0.7

* 4 The Data Register and Extended Data Register is as illustrated below.

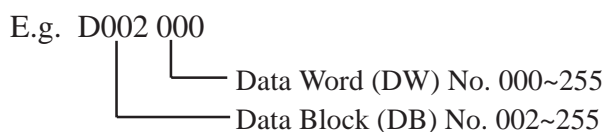

* 5 The Extended Data Register is possible only with S5 135U/155U.



Note: For information about Bit Write process differences, see the end of this section.

■ **SIMATIC S7-200 Series**

 Setup System Area here.

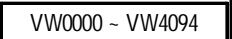
Device	Bit Address	Word Address	Particulars	
Input	I00 ~ I77	IW0 ~ IW6	*1,2	
Output	Q00 ~ Q77	QW0 ~ QW6	*1,2	
Internal Memory	M000 ~ M317	MW00 ~ MW30	*1,2	
Special Memory	SM000 ~ SM857	SMW00 ~ SMW84	*1,2	
Timer Bit	T000 ~ T127	---	H/L	
Counter Bit	C00 ~ C63	---		
Variable Memory	---	 VW0000 ~ VW4094		*1
Timer Word	---	TW000 ~ TW127		
Counter Word	---	CW000 ~ CW127		



Note: This maximum range may not be supported by some PLC configurations.

■ **SIMATIC S7-300/400 Series (CPU Direct Connection via MPI Port)**

 Setup System Area here.

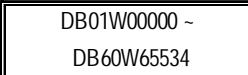
Device	Bit Address	Word Address	Particulars
Input	E000000 ~ E001277	EW00000 ~ EW00126	*1,2
Output	A000000 ~ A001277	AW00000 ~ AW00126	*1,2
Internal Bit	M000000 ~ M002557	MW00000 ~ MW00254	*1,2
Data Block	DB01W000000 ~ DB60W655357	 DB01W00000 ~ DB60W65534	*1,2,3
Timer Word	---	T00000 ~ T00127	H/L
Counter Word	---	Z00000 ~ Z00063	

*1 Word addressing of Byte devices so only every second address can be accessed (e.g. MW0,2,4,.....).

*2 The bit position is the last digit entered. There is no '.' delimiter - e.g. I3.7 is equivalent to I37 in GP-PRO/PBIII.

*3 The addressing format for entering on GP-PRO/PBIII is different from the convention used in the S7-300 - e.g. DB63W00020 is equivalent to DB63.DBW20.



Note: This maximum range may not be supported by some PLC configurations.

■ SIMATIC S7-300/400 (via 3964/RK512)

Setup System Area here.

Device	Bit Address	Word Address	Particulars	
Data Memory	---	D01W000 ~ D60W254	*1*2*3	H/L



It is possible to enable/disable the Block Check Character (BCC) in PLC to GP communications.

This can be performed via the GP's OFFLINE mode, or, via the GP-PRO/PBIII Editor's Mode Area's "Option" Command.

**1 Some Data Blocks are reserved for the 3964R interpreter program: DB2,DB3,DB5 & DB10.*

**2 Word addressing of Byte devices so only every second address can be accessed (e.g. D10W0,2,4,.....).*

**3 The addressing format for entering on GP-PRO/PB III is different from the convention used in the S7-300 - e.g. DB63W00020 is equivalent to DB63.DBW20.*

■ SIMATIC 505 Series

Setup System Area here.

Device	Bit Address	Word Address	Particulars
Variable Memory	—————	V00001 ~ V26624	
Word Input	—————	WX00001 ~ WX08192	*1
Word Output	—————	WY00001 ~ WY08192	
Discrete Input accessed as bit	X0001 ~ X8192	—————	
Discrete Output accessed as bit	Y0001 ~ Y8192	—————	
Control Relay Accessed as bit	CR00001 ~ CR32768	—————	
Loop Gain	—————	LKC0001 ~ LKC0064	*2
Loop Reset	—————	LTi0001 ~ LTi0064	*2
Loop Rate	—————	LTD0001 ~ LTD0064	*2
Loop Alarm High Limit	—————	LHA0001 ~ LHA0064	*2
Loop Low Alarm Limit	—————	LLA0001 ~ LLA0064	*2
Loop Process Variable	—————	LPV0001 ~ LPV0064	*2
Loop PV High Limit	—————	LPVH0001 ~ LPVH0064	*2
Loop PV Low Limit	—————	LPVL0001 ~ LPVL0064	*2
Loop Orange Deviation Limit	—————	LODA0001 ~ LODA0064	*2
Loop Yellow Deviation Alarm Limit	—————	LYDA0001 ~ LYDA0064	*2
Loop Sample Rate	—————	LTS0001 ~ LTS0064	*2
Loop Setpoint	—————	LSP0001 ~ LSP0064	*2
Loop Output	—————	LMN0001 ~ LMN0064	*2
Loop Error	—————	LERR0001 ~ LERR0064	*1 *2
Loop Bias	—————	LMX0001 ~ LMX0064	*2
Loop Alarm High-High Limit	—————	LHHA0001 ~ LHHA0064	*2
Loop Low-Low Alarm Unit	—————	LLLA0001 ~ LLLA0064	*2
Loop Rate of Change Alarm Limit	—————	LRCA0001 ~ LRCA0064	*2
Loop Setpoint High Point	—————	LSPH0001 ~ LSPH0064	*2

(Continued on next page)

■ SIMATIC 505 Series (Continued on next page)

Device	Bit Address	Word Address	Particulars		
Loop Setpoint Low Limit	_____	LSPL0001 ~ LSPL0064	*2		
Loop Alarm Deadband	_____	LADB0001 ~ LADB0064	*2		
Loop V-flags	_____	LVF0001 ~ LVF0064		L/H	
Most Significant Word of Loop C-flags	_____	LCFH0001 ~ LCFH0064			
Least Significant Word of Loop C-flags	_____	LCFL0001 ~ LCFL0064			
Analog Alarm/Alarm Acknowledge Flags	_____	AADB0001 ~ AADB0128	*2		
Most Significant Word of Analog Alarm C-flags	_____	ACFH0001 ~ ACFH0128		L/H	
Least Significant Word of Analog Alarm C-flags	_____	ACFL0001 ~ ACFL0128			
Analog Alarm Error	_____	AERR0001 ~ AERR0128	*1*2		
Analog Alarm High Alarm Limit	_____	AHA0001 ~ AHA0128	*2		
Analog Alarm High-High Alarm Limit	_____	AHHA0001 ~ AHHA0128	*2		
Analog Alarm Low Alarm Limit	_____	ALA0001 ~ ALA0128	*2		
Analog Alarm Low-Low Alarm Limit	_____	ALLA0001 ~ ALLA0128	*2		
Analog Alarm Loop Orange Deviation Alarm Limit	_____	AODA0001 ~ AODA0128	*2		
Analog Alarm Process Variable	_____	APV0001 ~ APV0128	*2		
Analog Alarm Rate of Change Alarm Limit	_____	ARCA0001 ~ ARCA0128	*2		
Analog Alarm Setpoint	_____	ASP0001 ~ ASP0128	*2		
Analog Alarm SP High Limit	_____	ASPH0001 ~ ASPH0128	*2		
Analog Alarm SP Low Limit	_____	ASPL0001 ~ ASPL0128	*2		
Analog Alarm Sample Rate	_____	ATS0001 ~ ATS0128	*2		
Analog Alarm Yellow Deviation Alarm Limit	_____	AYDA0001 ~ AYDA0128	*2		
Timer/Counter Preset	_____	TCP0001 ~ TCP1024	*3		L/H
Timer/Counter Current	_____	TCC0001 ~ TCC1024	*3		
Drum Counter Preset	_____	DCP0101 ~ DCP6416	*3*4		
Drum Step Preset	_____	DSP0001 ~ DSP0064	*3*5*6		
Drum Step Current	_____	DSC0001 ~ DSC0064	*3*5*6		
Status Word	_____	STW0001 ~ STW0222	*1		
Drum Count Current	_____	DCC0001 ~ DCC0064	*1		

(Continued on next page)

(From previous page)

- *1 *The GP cannot write data to this device. Use it only for reading.*
- *2 *This device uses Float. When this type of device is used, only the E-tag and K-tag's "32 bit Float" setting can be used.*
- *3 *32 bit reading / writing, or reading / writing a K-tag's text string cannot be performed.*
- *4 *Address entry method:*
 - Enter 1.01 as "101"*
 - Enter 1.02 as "102"*
 - Enter 1.03 as "103"*
 - ...*
 - Enter 1.16 as "116"*
 - Enter 2.01 as "201"*
 - Enter 2.02 as "202"*
 - ...*
 - Enter 64.15 as "6415"*
 - Enter 64.16 as "6416"*
- *5 *Entry range is from 0 to 15 (dec.)*
- *6 *+1 is added to all data input from the GP to the PLC. -1 is added to all data output from the PLC to the GP.*

<i>GP</i>	<i>→</i>	<i>PLC</i>	
<i>1</i>	<i>→</i>	<i>2</i>	<i>("1" entered from the GP is changed to "2" in the PLC.)</i>
<i>5</i>	<i>←</i>	<i>6</i>	<i>("6" sent from the PLC to the GP will become "5".)</i>

2.16.4 Environment Setup

The following lists Digital's recommended PLC and GP communication setups.

■ SIMATIC S5 Series (using Link I/F)

GP Setup		Link I/F Setup	
Baud Rate	19200 bps	Baud Rate	19200 bps
Data Length	8 bits	Data Bit	8 bits
Stop Bit	1 bit	Stop Bit	1 bit
Parity Bit	Even	Parity Bit	Even
Data Flow Control	ER Control		---
Communication Format (RS-232C)	RS-232C		---
Communication Format (RS-422)	4-wire type		---
Unit No.	0 (fixed)		---

■ SIMATIC S5 Series (CPU Direct Connection)

GP Setup		PC Link Unit Setup	
Baud Rate	9600 bps (fixed)		---
Data Length	8 bits (fixed)		---
Stop Bit	1 bit (fixed)		---
Parity Bit	Even (fixed)		---
Data Flow Control	ER Control (fixed)		---
Communication Format	RS-232C (fixed)		---
Unit No.	0 (fixed)		---

System Data Area Setup

- **SYSTEM DATA AREA START DB**—used to setup the Data Register's Data Block (DB) Number.
- **SYSTEM DATA AREA START DW**—used to setup the Data Register's Data Word (DW) Number.

Reference Refer to the previous section, "2.16.3 Supported Devices", for the setup range.

If Link I/F is used, the system's number is indicated before the DB (Data Block) on the INITIALIZE area's [SETUP OPERATION SURROUNDINGS] screen. Changing this number, however, is not necessary since this data will be used only for future expansion.



- The method of writing bits will differ depending on the GP series.

<GP-*30 series>

When the bit write operation (other than *Reverse*) is performed, the corresponding word address will set the bits to 0 (except the designated bits).

<Except GP-*30 series>

When the bit write operation is performed, the GP reads the PLC's corresponding word address and turns a bit ON, then send back to PLC. Do not write to the word address from the ladder program in the middle of this operation.

- When running a GP-*30 Series ladder program, be aware of the above points.

■ SIMATIC S7-200 Series

GP Setup		PC Link Unit Setup
Baud Rate	9600 bps	---
Data Bit	8 bits	---
Parity Bit	Even	---
Stop Bit	1 bit	---
Data Flow Control	ER Control	---
Communication-format	RS-422 2-wire type	---
GP No.	1	---
PLC No.	2	2

■ **SIMATIC S7-300/400 Series (CPU Direct via MPI Port)**

GP Setup		PC Link Unit Setup
Baud Rate	19200 bps	---
Data Bit	8 bits	---
Parity Bit	ODD	---
Stop Bit	1 bit	---
Data Flow Control	ER Control	---
Communication-format	RS232C	---

MPI Configuration	(This configuration can now be performed via the Editor's [Mode] -> [Option] menu)
Local Node Address (GP address)	0 to 126
Target Node Address (PLC address)	0 to 126
Highest Node	15/31/63 or 126



- **The GP's node address must not be the same as the PLC's MPI Node address.**
- **The Highest Node parameter should correspond to the group in which the PLC's node address occurs. E.g. if the PLC's node address is 16 then the Highest Node parameter should be 31. The GP's node address should be less than or equal to the Highest Node.**

■ **SIMATIC S7-300 (via 3964/RK512)**

GP Setup		PC Link Unit Setup
Communication-format	RS-232C	---
Baud Rate	19200 bps	---
Data Bit	8 bits	---
Parity Bit	Even	---
Stop Bit	1 bit	---
Data Flow Control	ER Control	---



It is possible to enable/disable the Block Check Character (BCC) in communications between the PLC and the GP. This configuration can be performed via the Editor's [Mode] -> [Option] menu.

■ SIMATIC S7-400 (via 3964/RK512)

GP Setup		PC Link Unit Setup
Communication-format	RS422	---
Baud Rate	19200 bps	---
Data Bit	8 bits	---
Parity	Even	---
Stop Bit	1 bit	---
Data Flow Control	ER Control	---

■ SIMATIC 505

GP Setup		PLC Settings	
Baud Rate	19200 bps	Baud Rate	19200 bps
Data Length	7 bits	Data Length	7bits (fixed)
Stop Bit	1 bit	Stop Bit	1bit (fixed)
Parity Bit	Odd	Parity Bit	Odd (fixed)
Data Flow Control	ER Control	_____	_____
Communication Format (RS-232C)	RS-232C	Communication Format (RS-232C)	Turn on the Dip Switch 1 on CPU.
Communication Format (RS-422)	RS-422 (4-wire type)	Communication Format (RS-422)	Turn on the Dip Switch 1 on CPU.



2.17 Rockwell (Allen-Bradley)

2.17.1 System Structure



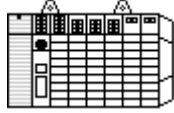

The following describes the system structure for connecting the GP to Rockwell (Allen-Bradley) PLCs.

Reference The Cable Diagrams mentioned in the following tables are listed in the section titled "2.17.2 Cable Diagrams".

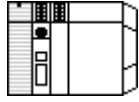

■ AB SLC 500 Series (using CPU unit Link I/F)

CPU	Cable Diagram	GP
		
SLC-5/03 SLC-5/04	RS-232C (Cable Diagram 1)	GP Series

■ AB PLC-5 Series (using Link I/F)

CPU	Link I/F	Cable Diagram	GP
	 DATA HIGHWAY PLUS		
All PLC-5 processors which can connect one of the link unit shown on the right.	1785-KE 1785-KE/C	RS-232C (Cable Diagram 2)	GP Series
	1770-KF2	RS-232C (Cable Diagram 3)	
		RS-422 (Cable Diagram 4)	

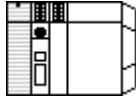
■ **AB PLC-5 Series (CPU Direct Connection)**

CPU *1	Cables Diagram	GP
		
PLC-5/11 PLC-5/20 PLC-5/30 PLC-5/40 PLC-5/40L PLC-5/60 PLC-5/60L	RS-232C (Cable Diagram 3) RS-422 (Cable Diagram 5)	GP Series

*1 Connect to Channel 0 (CH0).

2.17.2 Cable Diagrams

The cable diagrams illustrated below and the cable diagrams recommended by Rockwell (Allen-Bradley) may differ; however, using these cables for your PLC operations will not cause any problems.



Ground your PLC's FG terminal according to your country's applicable standard. For details, refer to the corresponding PLC manual.



- **Connect the FG line of the Shield cable to either the GP or PLC, depending on your environment. When using a connector hood and grounding the FG line, be sure to use an electrical conductor.**
- **For the RS-232C connection, use a cable length less than 15m.**
- **If a communications cable is used, it must be connected to the SG (signal ground).**
- **For the RS-422 connection, refer to Rockwell's PLC manual for the cable length.**

Cable Diagram 1 (RS-232C)

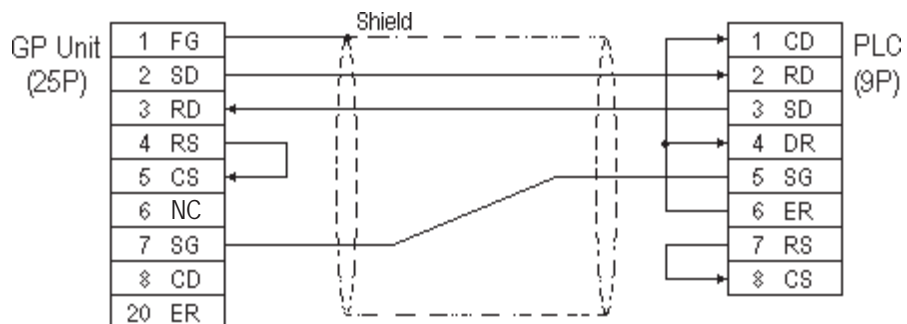

Cable Diagram 2 (RS-232C)

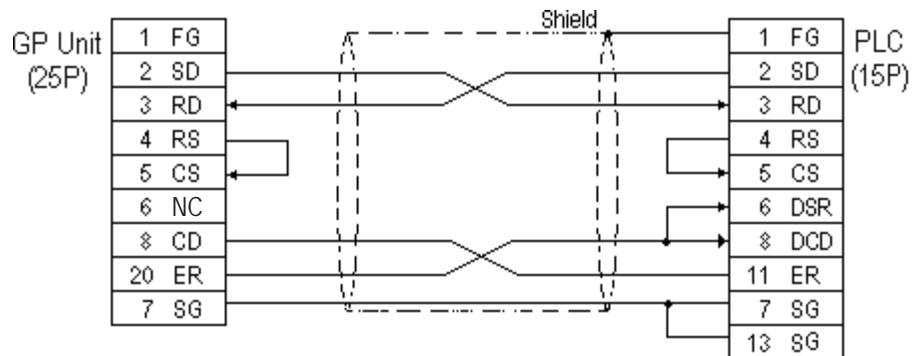

Cable Diagram 3 (RS-232C)

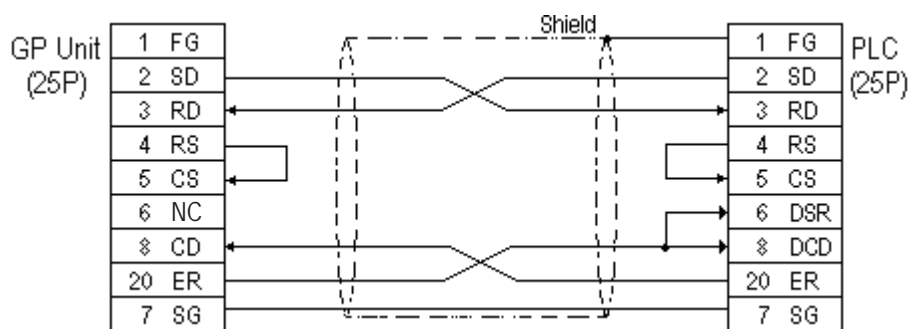

Cable Diagram 4 (RS-422)

- When using Digital's RS-422 connector terminal adapter, GP070-CN10-0

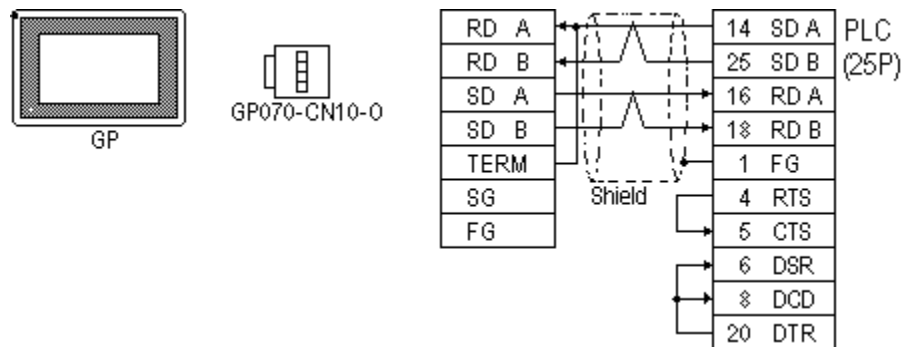

- When using Digital's RS-422 Cable, GP230-IS11-0

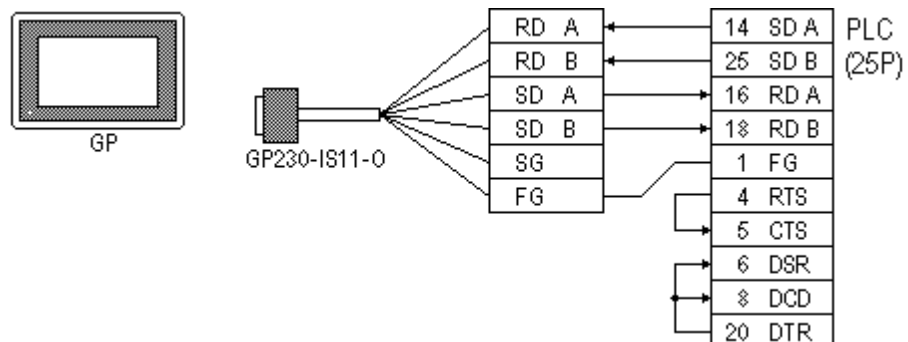

- When making your own cable connections

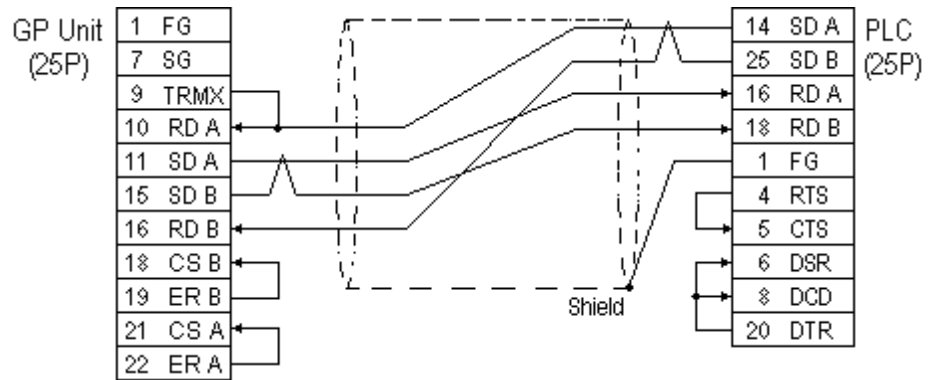

Note: When connecting the #9 and #10 pins in the GP Serial I/F, a termination resistance of 100Ω is added between RDA and RDB.

Cable Diagram 5 (RS-422)

- When using Digital's RS-422 connector terminal adapter, GP070-CN10-0

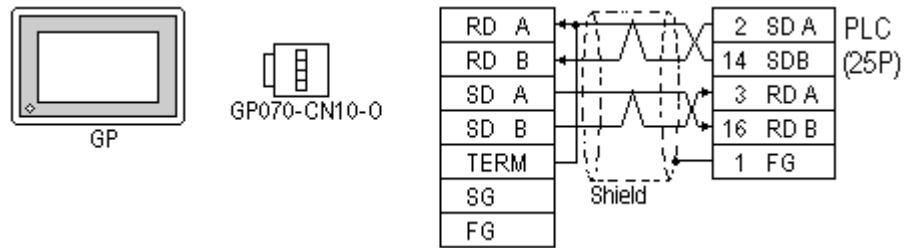

- When using Digital's RS-422 Cable, GP230-IS11-0

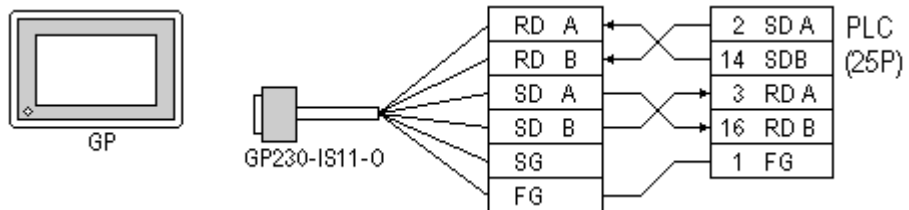

- When making your own cable connections

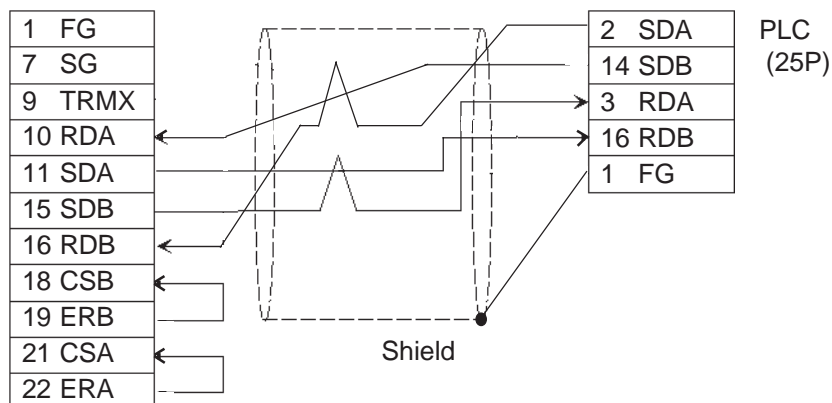



When connecting the #9 and #10 pins in the GP Serial I/F, a termination resistance of 100Ω is added between RDA and RDB.

2.17.3 Supported Devices

The following describes the range of devices supported by the GP.

AB SLC 500 Series

 Setup System Area here.

Device	Bit Address	Word Address	Particulars
Bit	B0030000 ~ B003255F B0100000 ~ B255255F	B0030000 ~ B003255 B010000 ~ B255255	H/L
Timer (TT: Timing Bit)	TT0040000 ~ TT0042550 TT0100000 ~ TT2552550	---	*1
Timer (DN: Completion Bit)	TN0040000 ~ TN0042550 TN0100000 ~ TN2552550	---	*1
Timer (PRE: Setup Value)	---	TP004000 ~ TP004255 TP010000 ~ TP255255	*2
Timer (ACC: Current Value)	---	TA004000 ~ TA004255 TA010000 ~ TA255255	*2
Counter (CU: Up Count)	CU0050000 ~ CU0052550 CU0100000 ~ CU2552550	---	*1 L/H
Counter (DC: Down Count)	CD0050000 ~ CD0052550 CD0100000 ~ CD2552550	---	*1
Counter (CN: Completion Bit)	CN0050000 ~ CN0052550 CN0100000 ~ CN2552550	---	*1
Counter (PRE: Setup Value)	---	CP005000 ~ CP005255 CP010000 ~ CP255255	*2
Counter (ACC: Current Value)	---	CA005000 ~ CA005255 CA010000 ~ CA255255	*2
Integer	---	N007000 ~ N007255 N010000 ~ N255255	 H/L

*1 As in Example 4 in the following Note section, enter a 0 at the end.

*2 When reading and writing consecutive addresses that are all two words or longer, reading will take longer than for other devices, and the overall screen refresh speed will be slower.



- File Numbers 0~7 are the User's default files.
- A PLC COM Error (02:10) develops when a device cannot be allotted into the PLC data table map.
- According to the SLC500 specifications, the input and output relays cannot perform direct reads and writes. As a result, perform the following procedures via the PLC:

When reading data; use a ladder program to move the input and output relay data either as bits or as integers, and then read out those bits or integers.

When writing data; write the data as either bits or integers, and then use the ladder program to move the data to the input or output relays.

- In Rockwell (Allen-Bradley) PLCs, the structure of each device data is determined from the *Element*; in GP-PRO/PBIII for Windows there is no concept called the *Element*. Use the following examples when entering device data.

Examples

PLC Data

GP-PRO/PBIII Input

■ When Using Elements

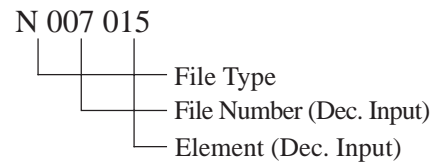
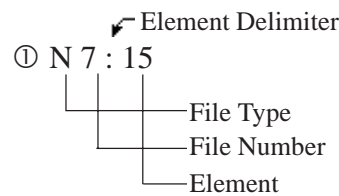

■ When Using Words

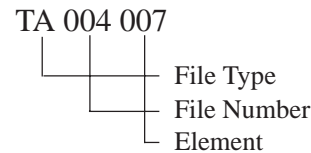
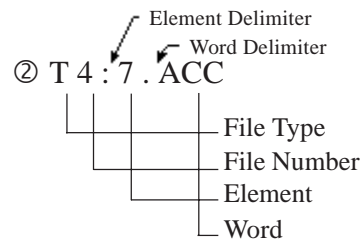



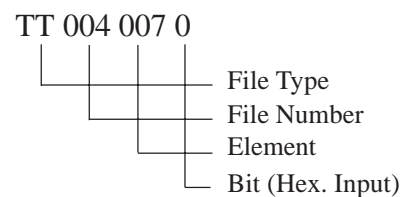
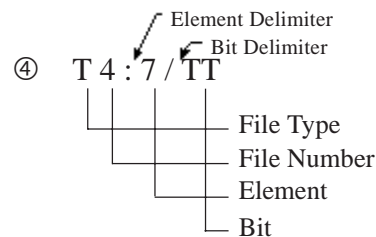
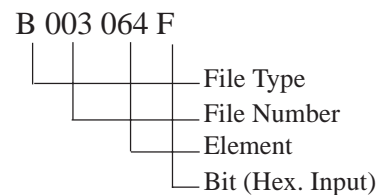
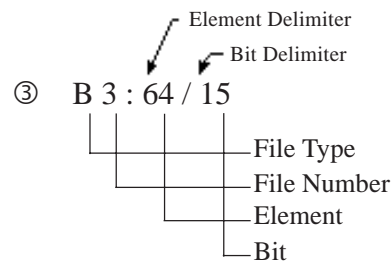

■ When Using Bits



■ AB PLC-5 Series

 Setup System Area here.

Device	Bit Address	Word Address	Particulars	
Input Relay	I00000 ~ I27717	I000 ~ I277		H/L
Output Relay	O00000 ~ O27717	O000 ~ O277		
Internal Relay	B300000 ~ B6799915	B3000 ~ B67999		
Timer (TT: Timing Bit)	TT3000 ~ TT67999	---		L/H
Timer (TD: Complete Bit)	TD3000 ~ TD67999	---		
Counter (CC: Count)	CC3000 ~ CC67999	---		
Counter (CD: Complete Bit)	CD3000 ~ CD67999	---		
Timer (ACC: Current Value)	---	TA3000 ~ TA67999		
Timer (PRE: Setup Value)	---	TP3000 ~ TP67999		
Counter (ACC: Current Value)	---	CA3000 ~ CA67999		
Counter (PRE: Setup Value)	---	CP3000 ~ CP67999		
Data Register Integer	---	N3000 ~ N67999		
Data Register BCD	---	D3000 ~ D67999		
Data Register ASCII	---	A3000 ~ A67999		



- The range of supported devices may be different depending on your CPU.
- In Rockwell (Allen-Bradley) PLCs, the structure of each device data is determined from the *Element*; in GP-PRO/PBIII for Windows there is no concept called the *Element*. Use the following examples when entering device data.

PLC Data

■ When Using Elements

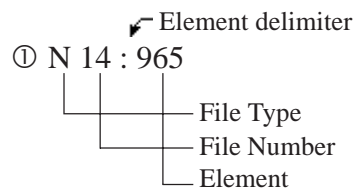

GP-PRO/PBIII Input

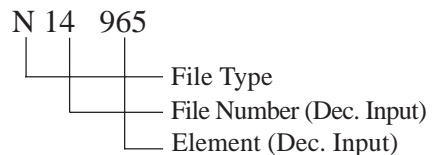

PLC Side

GP-PRO/PBIII Input

■ *When Using Words*

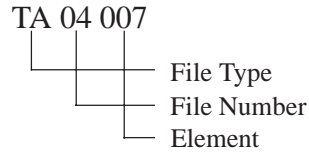
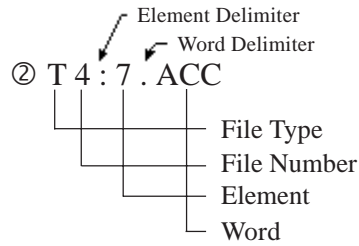

■ *When Using Bits*

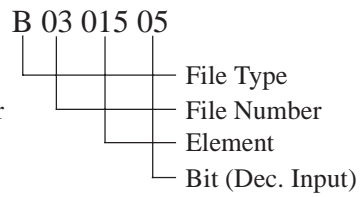
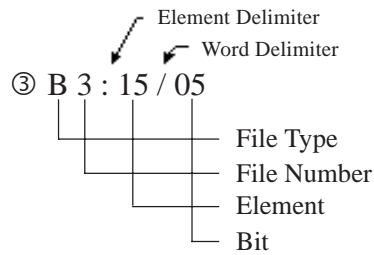

B301505 represents the same data as B3/245 (number 245 bits of file number 3). However, GP-PRO/PBIII for Windows cannot be used to input B3/245 directly.

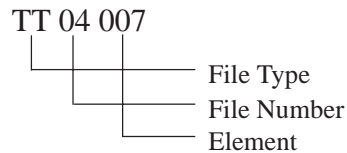
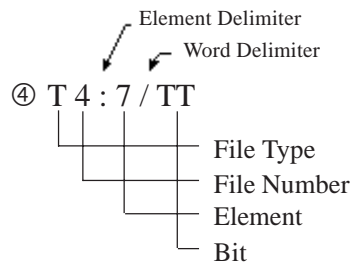

- **There is no File Number for the *Input Relay* and *Output Relay*. Also, the Element and Bit Numbers are Hexadecimal.**

PLC Side

GP-PRO/PBIII Input

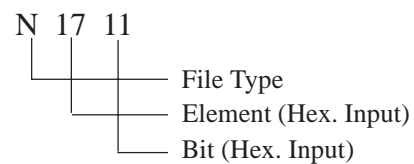
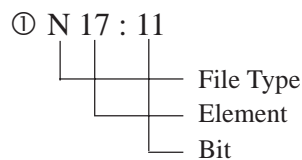

2.17.4 Environment Setup

The following tables list Digital's recommended PLC and GP communication settings.

■ AB SLC 500 Series

GP Setup		Special Interface Module Setup	
Baud Rate	19200 bps	Baud Rate	19200 bps
Data Length	8 bits (fixed)	---	
Stop Bit	1 bit (fixed)	---	
Parity Bit	EVEN	Parity Bit	EVEN
Data Flow Control	ER Control	---	
Communication Format	RS-232C	---	
---		Communication Driver	DF1 HALF-DUPLEX SLAVE ^{*1}
---		Duplicate Packet Detection	DISABLE ^{*1}
---		Error Detection	BCC ^{*1}
---		Control Line	No Handshaking ^{*1}
Unit No. (DH GP) ^{*2}	0	Station Address ^{*2}	0

* 1 Will not operate with any other settings.

* 2 Setup the Station Address and the GP's Unit No. (DH GP) address to the same value (address set as decimal values). It is unnecessary to setup the DH PLC address.

Reference Specifying DH addresses

■ AB PLC-5 Series

GP Setup		CPU (CH0), 1785-KE, 1770-KF2	
Baud Rate	19200 bps	Baud Rate	19200 bps
Data Length	8 bits (fixed)	Data Length	8 bits (fixed)
Stop Bit	1 bit (fixed)	Stop Bit	1 bit (fixed)
Parity Bit	EVEN	Parity Bit	EVEN
Data Flow Control	ER Control	---	
Communication Format (RS-232C)	RS-232C	Communication Format (RS-232C)	RS-232C
Communication Format (RS-422)	4-wire type	Communication Format (RS-422)	RS-422A
---		Comm. protocol	Half duplex (DF1 Slave for CH0) ^{*1}
---		Duplicate Detect	OFF ^{*1}
---		Error Check	BCC ^{*1}
---		Control Line	NO HANDSHAKING ^{*1}
---		Other CH0 Parameters	50
---		DF1 retries	3
---		Diag file	0 (unused file)
---		RTS send delay	0
---		RTS off delay	0
---		Network link ^{*2}	Data Highway Plus
Unit No. (DH GP) ^{*3}	0	Station Address ^{*4*5} (1785-KE, 1770-KF2 side)	0
Unit No. (DH PLC) ^{*3}	1	Station Address ^{*4} (CPU side)	1

**1 Will not operate with any other settings.*

**2 This is the KF2 setup*

**3 Set the DH GP to station address 1785-KE or 1770-KF2, and set the DH PLC's to the CPU's station address. When using the 1785-KE or 1770-KF2, enter different numbers for the DH GP and DH PLC addresses. With a direct CPU connection, enter the same values in the DH GP and DH PLC addresses. With the GP in Offline Mode, use the "Operating Environment Setup" area to enter the DH address (DH, GP, DH, PLC) base 10 (decimal) values.*

Reference Specifying DH addresses

**4 When using programming equipment, make sure the Terminal Address (programming equipment address) and the Station Address do not overlap.*

**5 Unavailable for CPU Direct Connection.*



Note: When using CH0, setup the CPU to *Slave*; do not setup as *Point to Point*.

■ Specifying DH addresses

Set up the operating environment at the initial setup when the GP is in the OFFLINE mode.

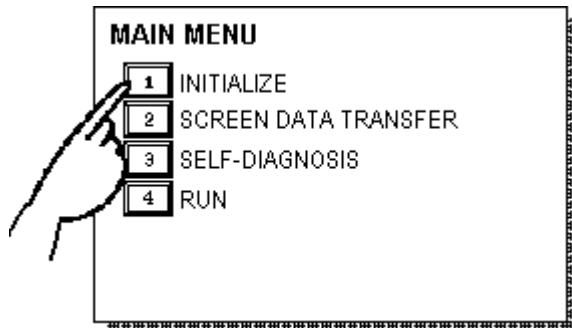

① Touch item #1, INITIALIZE. The INITIALIZE menu will appear.

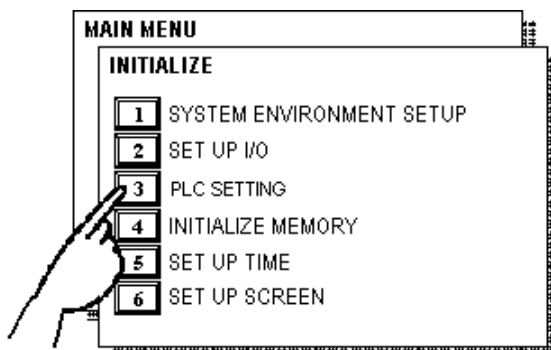

② Touch item #3, PLC SETTING. The PLC SETTING menu will appear.

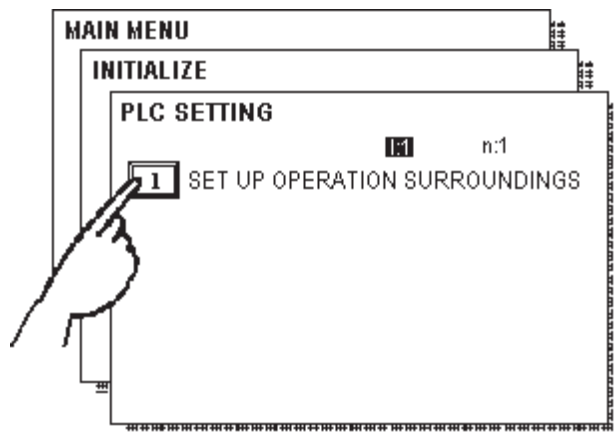

③ Touch selection [1:1] and then item #1, SET UP OPERATION SURROUNDINGS. The selected option is then highlighted.

SET UP OPERATION SURROUNDINGS		SET	CANCEL
SYSTEM DATA AREA	START FILE	[]	
	START ADDRESS	[]	
DH ADDRESS (DECIMAL)	GP	[]	
	PLC	[]	
SYSTEM AREA	READING AREA SIZE (0-256)	[]	

④ Specify the DH addresses.





2.18 Keyence

2.18.1 System Structure

The following describes the system structure for connecting the GP to Keyence PLCs.

Reference The Cable Diagrams mentioned in the following tables are listed in the section titled "2.18.2 Cable Diagrams".



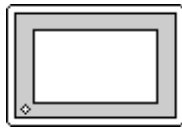

■ KZ-300/KZ-350 Series (using Link I/F)

CPU	Link I/F	Cable Diagram	GP
	 PC Link Unit		
KZ-300 KZ-350	KZ-L2	RS-232C Port 1 Connection (Cable Diagram 1) RS-232C Port 2 Connection (Cable Diagram 2) RS-422 Port 2 Connection (Cable Diagram 3)	GP Series

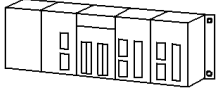

Port 1 and Port 2 can be connected at the same time on the GP. When connected at the same time, the Communication Setup for Port 1 and Port 2 must be the same.





■ KZ-A500 Series (using Link I/F)

CPU	Link I/F	Cable Diagram	GP
			
KZ-A500	KZ-L10	RS-232C , connected to Port 1. (Cable Diagram 4) RS-232C , connected to Port 2. (Cable Diagram 2) RS-232C , connected to Port 2. (Cable Diagram 3)	GP Series

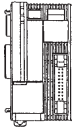

Port 1 (RS232C), Port 2 (RS232-C or RS422) and the modular controller on CPU unit can be used at the same time.

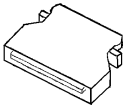
■ **KZ-A500** (CPU Direct Connection)

CPU	Cables	Connector	GP
			
KZ-A500	Keyence Corp.'s OP-26487	Keyence Corp.'s OP-26485	GP Series

2.18.2 Cable Diagrams

The cable diagrams illustrated below and the cable diagrams recommended by Keyence may differ, however, using these cables for your PLC operations will not cause any problems.



- Connect the FG line of the Shield cable to the GP.
- For the RS-232C connection, use a cable length less than 15m.
- If a communications cable is used, it must be connected to the SG (signal ground).
- For the RS-422 connection, refer to Keyence's PLC manual for the cable length.

Cable Diagram 1 (RS-232C)

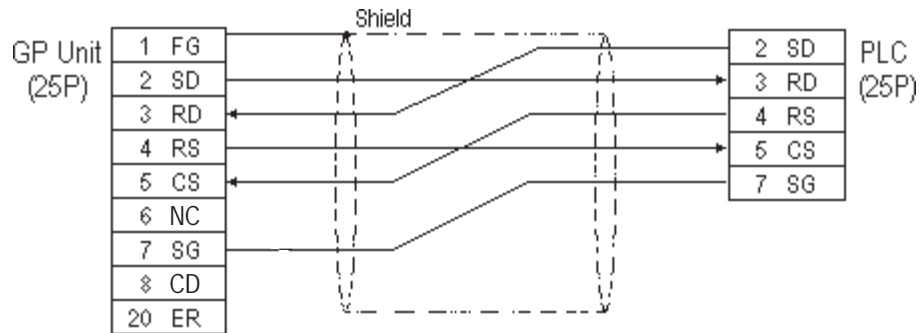

Cable Diagram 2 (RS-232C)

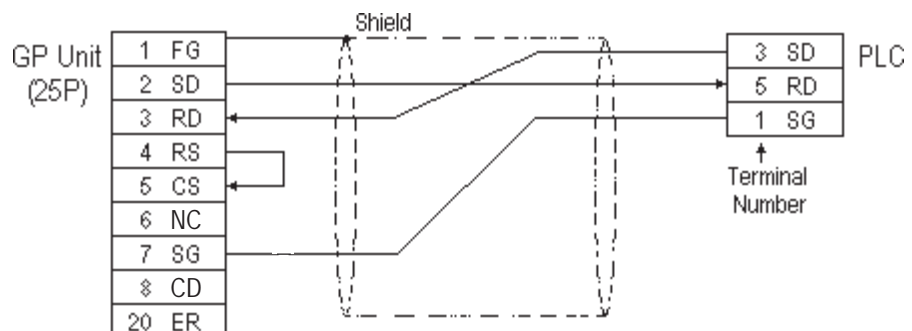

Cable Diagram 3 (RS-422)



Turn the PLC's Termination Resistor switch ON.



The reading of the A and B signals is reversed on the GP and PLC.

- When using Digital's RS-422 connector terminal adapter, GP070-CN10-0

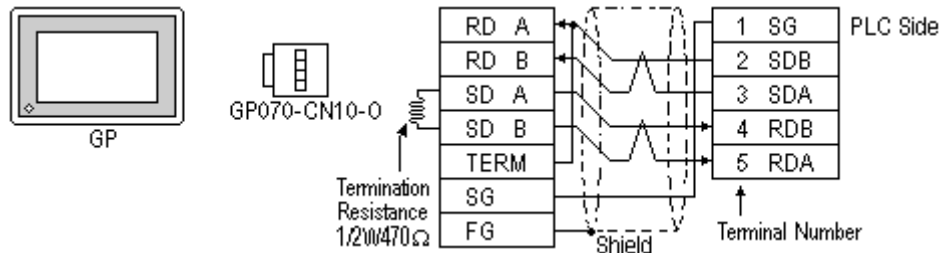

- When using Digital's RS-422 Cable, GP230-IS11-0

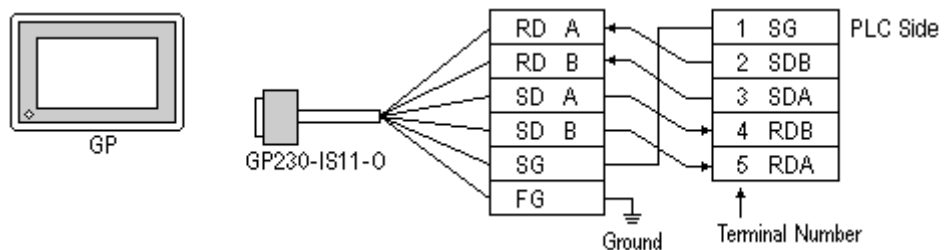

- When making your own cable connections

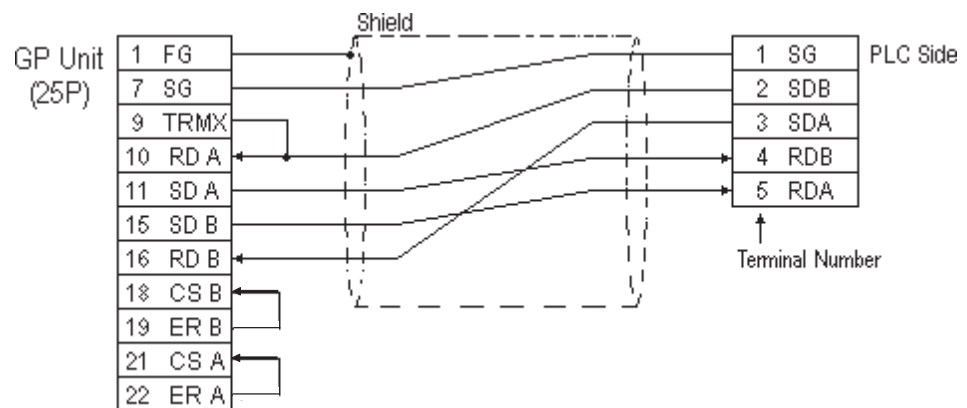

- Hidakawa Densen's H-9293A (C0-HC-ESV-3P*7/0.2) is the recommended cable.
- When connecting the #9 and #10 pins in the GP Serial I/F, a termination resistance of 100Ω is added between RDA and RDB.
- When using RS-422 connection, please check the cable length with Keyence PLC users manual.

Cable Diagram 4 (RS-232C) port1



- When using an RS-232C cable, the cable must be no longer than 15meters.
- When using an RS-422 cable, the cable must be no longer than 500meters.

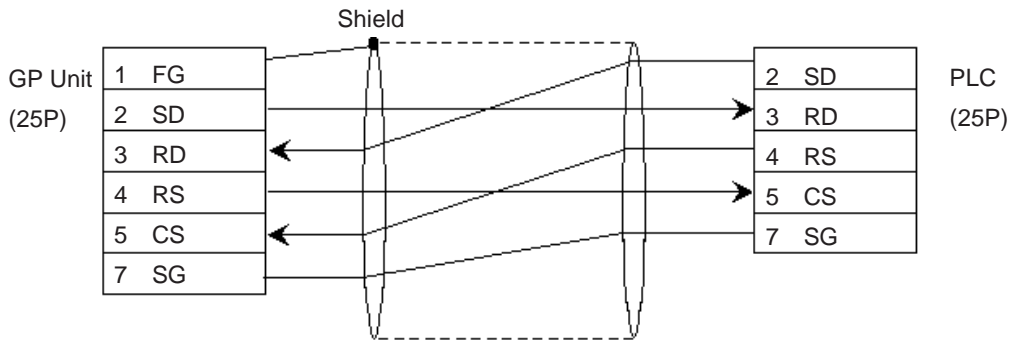

2.18.3 Supported Devices

The following describes the range of devices supported by the GP.

■ **KZ-300/KZ-350 Series**

 Set up System Area here.

Device	Bit Address	Word Address	Particulars	
Input Relay	0000 ~ 0009	00 ~ 00	L/H	
	7000 ~ 17415	70 ~ 174		
Output Relay	0500 ~ 0503	05 ~ 05	L/H	
	7500 ~ 17915	75 ~ 179		
Help Relay	0504 ~ 0915	---	L/H	
Internal Help Relay	1000 ~ 6915	10 ~ 69		
Special Help Relay	2000 ~ 2915	20 ~ 29		
Timer (contact)	T000 ~ T249	---		
Counter (contact)	C000 ~ C249	---		
Timer (current value)	---	T000 ~ T249		
Counter (current value)	---	C000 ~ C249		
Data Memory	---	DM0000 ~ DM9999		[Bit] 5
Temporary Data Memory	---	TM00 ~ TM31		[Bit] 5

(See following page for footnote information)

* 1 Address numbers *000~*400 are available for the bit device addresses, and *0~*4 are available for the word addresses displayed.

Bit Address	Word Address
addr 7000	70
addr 7001 to addr 7400	71 to 74
addr 8000	80
addr 8100 to addr 8400	81 to 84
addr 17000 to addr 17400	170 to 174

* 2 Address numbers *500~*900 are available for the bit device addresses, and *5~*9 are available for the word addresses displayed.

Bit Address	Word Address
addr 7500	75
addr 7600 to addr 7900	76 to 79
addr 8500	85
addr 8600 to addr 8900	86 to 89
addr 17500 to addr 17900	175 to 179

■ **KZ-A500** (CPU Direct Connection) Set up System Area here.

Device	Bit Address	Word Address	Particulars	
Input Relay	X0000 ~ X07FF	X0000 ~ X07F0		L/H
Output Relay	Y0000 ~ Y07FF	Y0000 ~ Y07F0		
Internal Relay	M0000 ~ M8191	M000 ~ M8176		
Latch Relay	L0000 ~ L8191	---		
Special Relay	M9000 ~ M9255	M9000 ~ M9240		
Annunciator	F0000 ~ F2047	F0000 ~ F2032		
Link Relay	B0000 ~ B0FFF	---		
Timer (contact)	TS0000 ~ TS2047	---		
Timer (coil)	TC0000 ~ TC2047	---		
Counter (contact)	CS0000 ~ CS1023	---		
Counter (coil)	CC0000 ~ CC1023	---		
Timer (current value)	---	TN0000 ~ TN2047		
Counter (current value)	---	CN0000 ~ CN1023		
Data Register	---	D0000 ~ D6143		
Special Register	---	D9000 ~ D9255		
Link Register	---	W0000 ~ W0FFF		
File Register	---	R0000 ~ R8191		

■ **KZ-A500** (using Link I/F)

Set up System Area here.

Device	Bit Address	Word Address	Particulars
Input Relay	X0000 ~ X07FF	X0000 ~ X07F0	<input type="text" value="***0"/>
Output Relay	Y0000 ~ Y07FF	Y0000 ~ Y07F0	<input type="text" value="***0"/>
Internal Relay	M0000 ~ M8191	M0000 ~ M8176	<input type="text" value="÷16"/>
Latch Relay	L0000 ~ L8191	L0000 ~ L8176	<input type="text" value="÷16"/>
Link Relay	B0000 ~ B0FFF	—————	
Annunciator Relay	F0000 ~ F2047	F0000 ~ F2032	<input type="text" value="÷16"/>
Special Relay	M9000 ~ M9255	M9000 ~ M9240	<input type="text" value="÷16"/>
Timer (connect)	TS0000 ~ TS2047	—————	
Timer (coil)	TC0000 ~ TC2047	—————	
Counter (connect)	CS0000 ~ CS1023	—————	
Counter (coil)	CC0000 ~ CC1023	—————	
Timer (current value)	—————	TN0000 ~ TN2047	
Counter (current value)	—————	CN0000 ~ CN1023	
Data Register	—————	<input type="text" value="D0000 ~ D6143"/>	<input type="text" value="Bit15"/>
Link Register	—————	W0000 ~ W0FFF	<input type="text" value="BitF"/>
File Register	—————	R0000 ~ R8191	<input type="text" value="Bit15"/>
Special Register	—————	D9000 ~ D9255	<input type="text" value="Bit15"/>

L/H

2.18.4 Environment Setup

The following lists Digital's recommended PLC and GP communication setups.

■ KZ-300/KZ-350 Series

GP Setup		PC Link Unit Setup	
Baud Rate	19200 bps	Baud Rate	19200 bps
Data Length	7 bits	Data Bit	7 bits
Stop Bit	2 bits	Stop Bit	2 bits
Parity Bit	Even	Parity Bit	Even
Data Flow Control	ER Control	---	
Communication Format (RS-232C)	RS-232C	Port 2 Toggle Switch (RS-232C) ^{*1}	RS-232C
Communication Format (RS-422)	4-wire type	Port 2 Toggle Switch (RS-422) ^{*1}	RS-422A
---		RUN Mode	Link Mode
Unit No.	0	Station Number	0

**1 Setup not necessary when using Port1.*

■ KZ-A500 (CPU Direct Connection)

GP Setup		PLC Setup
Baud Rate	9600 bps	---
Data Length	8 bits (fixed)	---
Stop Bit	1 bit (fixed)	---
Parity Bit	Odd (fixed)	---
Data Flow Control	ER Control	---
Communication Format (RS-232C)	RS-232C	---
Unit No.	0 (fixed)	---



Effect of PLC program on cycle time

If the KZ-A500 is connected directly to the CPU, the cycle time of the PLC program is delayed by about 8% after communication with the GP begins.

■ **KZ-A500** (using Link I/F)

GP Setup		PLC Setup	
Baud Rate	19200bps *1	Baud Rate	19200bps
Data Length	7	Data Length	7
Stop Bit	1	Stop Bit	1
Parity Bit	None	Parity Bit	None
Data Flow Control	ER	_____	_____
Communication Format (RS-232C)	RS232C	RS-232C Communication Port	Port 1 or Port 2 *2
Communication Format (RS-422)	4-Wire Type	RS-422 Communication Port	Port 2 *3
_____		Communication Type	Normal
_____		Changing device data during RUN	Possible
_____		Checksum	Yes
_____		Operation Mode	Protocol Mode 4
Unit No.	0	STATION No.	0

*1 The maximum baud rate is 38400bps.

*2 When using an RS-232C cable on port 2, be sure to set the INTERFACE switch to “232C”(right side setting.) Also, set the TERMINATOR switch to OFF, since it will not be used.

*3 When using an RS-422 cable, set the INTERFACE switch to “422”(left side setting,) and the TERMINATOR switch to ON.





2.19 Shinko Electric

2.19.1 System Structure

The following describes the system structure for connecting the GP to Shinko Electric PLCs.

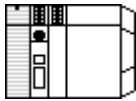
Reference *The Cable Diagrams mentioned in the following tables are listed in the section titled "2.19.2 Cable Diagrams".*

■ SELMART Series (using Link I/F)

CPU	Link I/F	Cable Diagram	GP
	LINK MODULE 		
SELMART	UC1-6	RS-232C (Cable Diagram 1)	GP Series

2.19.2 Cable Diagrams

The cable diagrams illustrated below and the cable diagrams recommended by Shinko Electric company may differ, however, using these cables for your PLC operations will not cause any problems.



Ground your PLC's FG terminal according to your country's applicable standard. For details, refer to the corresponding PLC manual.



- **Connect the FG line of the Shield cable to either the GP or PLC, depending on your environment. When using a connector hood and grounding the FG line, be sure to use an electrical conductor. The following connection diagrams show examples for connecting a shielded cable to the PLC.**
- **For the RS-232C connection, use a cable length less than 15m.**
- **If a communications cable is used, it must be connected to the SG (signal ground).**

Cable Diagram 1 (RS-232C)

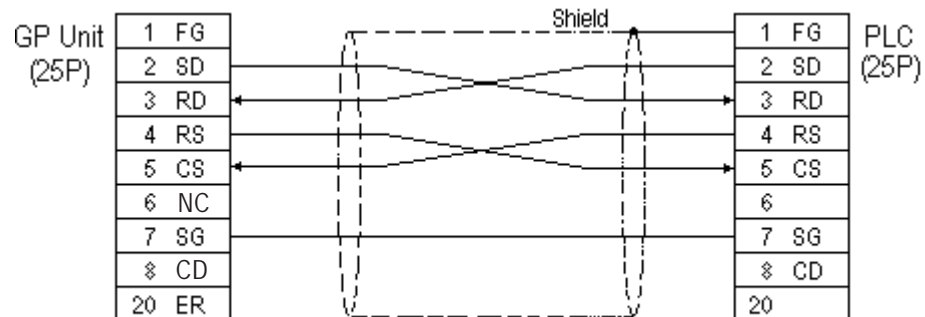

2.19.3 Supported Devices

The following describes the range of devices supported by the GP.

■ **SELMART Series**

Setup System Area Here

Device	Bit Address	Word Address	Particulars
Data Register	---	D00000 ~ D09999	Bit 5 *1 L/H

* 1 Data register values are allocated using the SELMART's V conversion. (Performed via the SELMART CPU card.)

2.19.4 Environment Setup

The following lists Digital's recommended PLC and GP communication settings.

■ **SELMART Series**

GP Setup		Link Module Setup	
Baud Rate	19200 bps	Baud Rate	19200 bps
Data Length	7 bits	Data Length	7 bits
Stop Bit	1 bit	Stop Bit	1 bit
Parity Bit	Even	Parity Bit	Even
Data Flow Control	ER Control		---
Communication Format	RS-232C		---
Unit No.	0	Unit No.	0







2.20 Matsushita Electric Industrial

2.20.1 System Structure

The following describes the system structure for connecting the GP to Matsushita Electronics PLCs.

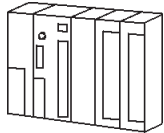
Reference The Cable Diagrams mentioned in the following tables are listed in the section titled "2.20.2 Cable Diagrams".

■ Panadac P7000 Series

CPU	Link I/F	Cable Diagram	GP
			
P7000-PLC-001 P7000-PLC-031H P7000-PLC-031S P7000-PLC-A01	SIO module P7000-GC P-001	RS-232C (Cable Diagram 1)	GP Series

2.20.2 Cable Diagrams

The cable diagrams illustrated below and the cable diagrams recommended by Matsushita Electronics may differ, however, using these cables for your PLC operations will not cause any problems.



Ground your PLC's FG terminal according to your country's applicable standard. For details, refer to the corresponding PLC manual.



- **Connect the FG line of the Shield cable to either the GP or PLC, depending on your environment.**
- **For the RS-232C connection, use a cable length less than 15m.**
- **If a communications cable is used, it must be connected to the SG (signal ground).**

Cable Diagram 1 (RS-232C)

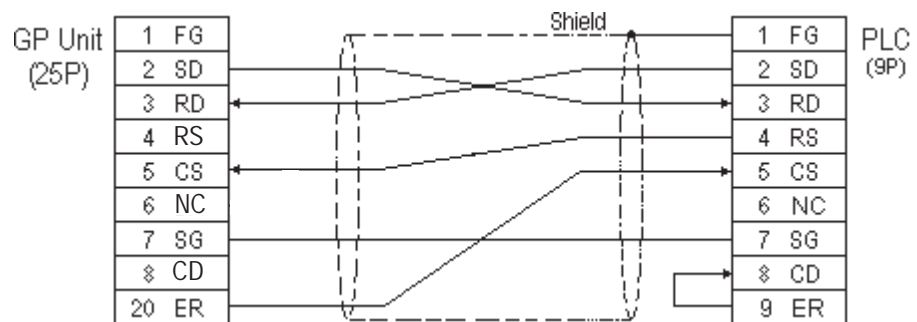

2.20.3 Supported Devices

The following describes the range of devices supported by the GP.

■ Panadac P7000 Series

 Setup System Area here.

	Device	Bit Address	Word Address	Particulars
B i t D e v i c e	Data Register	IN0000 ~ IN07FF	IN0000 ~ IN007F	
	Input/Output Relay	OT0000 ~ OT07FF	OT0000 ~ OT007F	
	Internal Relay	RL0000 ~ RL07FF	RL0000 ~ RL007F	
	Holding Relay	KR0000 ~KR03FF	KR0000 ~ KR003F	
	Link Relay	LK0000 ~ LK07FF	LK00000 ~ LK007F	
	Status Relay	ST0000 ~ ST01FF	ST0000 ~ ST001F	
	MC Status Relay	MS0000 ~ MS03FF	MS0000 ~ MS003F	
	Timer State Relay	TS0000 ~ TS01FF	TS0000 ~ TS001F	
	Timer-up Relay	TU0000 ~ TU01FF	TU0000 ~ TU001F	
	Count-up Relay	CU0000 ~ CU007F	CU0000 ~ CU0007	
	CPU Input Relay	CI0000 ~ CI01FF	CI0000 ~ CI001F	*1
	CPU Output Relay	C00000 ~ C001FF	C00000 ~ C0001F	
W o r d D e v i c e	Data Memory	M00000 ~ M07FFF	M0000 ~ M07FF	
	Link Register	LM00000 ~ LM07FFF	LM0000 ~ LM07FF	
	Timer (set value)	---	TM0000 ~ TM07FF	
	Timer (current value)		CT0000 ~ CT007F	
	Counter Value		TC0000 ~ TC01FF	*2
	Position Data	---	PM0000 ~ PM07FF	*3

*1 If a CPU module is not connected, these are handled as internal relays.

*2 This is a 32-bit device.

*3 If a 32-bit device NC module is not connected, this is handled as an internal relay.



If 2-word (32-bit) data are used, the vertical relation of addresses is shown as follows:

1	L (lower)
0	H (upper)

2.20.4 Environment Setup

The following lists Digital's recommended PLC and GP communication settings.

■ Panadac P7000 Series

GP Setup		Setting of SIO module	
Baud Rate	19200 bps	Baud Rate	19200 bps
Data Length	8 bits	Data Length	8 bits
Stop Bit	1 bit	Stop Bit	1 bit
Parity Bit	None	Parity Bit ON/OFF Even/Odd	None
Data Flow Control	ER Control	---	
Communication Format	RS-232C	---	
Unit No.	1	Slave address number	0
		Mode	COMMAND mode
		Delimiter	CR



The setting of the machine number is fixed, and cannot be specified on the PLC.



If there is any difference in the PLC and the GP settings, a communications error occurs.



The GP must be set to ER control.



2.21 Modicon

2.21.1 System Structure

The following describes the system structure for connecting the GP to Modicon PLCs.

Reference The Cable Diagrams mentioned in the following tables are listed in the section titled "2.21.2 Cable Diagrams".

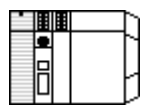
■ Modicon Modbus (CPU Direct Connection)

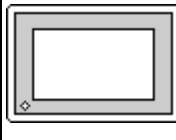
CPU	Cable Diagram	GP
		
884, 984A, 984B	RS-232C (Cable Diagram 1)	GP Series
Slot Mount 984	RS-232C (Cable Diagram 2)	

2.21.2 Cable Diagrams

The cable diagrams illustrated below and the cable diagrams recommended by Modicon may differ, however, using these cables for your PLC operations will not cause any problems.

Cable Diagram 1 (RS-232C)

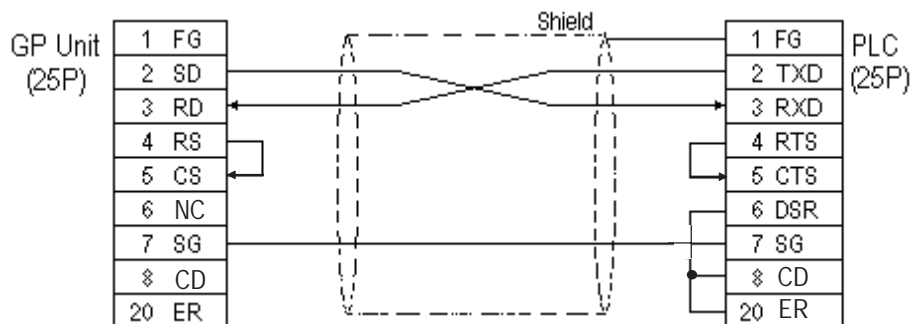

Cable Diagram 2 (RS-232C)

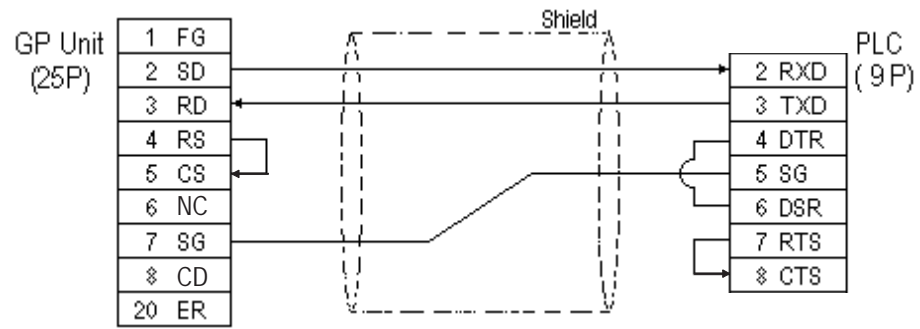

2.21.3 Supported Devices

The following describes the range of devices supported by the GP.

■ **Modicon Modbus (GP Master)**

 Setup System Area here.

Device	Bit Address	Word Address	Particulars
Output Bit	00001 ~ 08192	---	*1
Input Bit	10001 ~ 18192	---	*1*2
Output Register	---	40001~ 49999	L/H
Input Register	---	30001 ~ 39999	

* 1 Can also specify a word (16-bit data)

* 2 Cannot perform data writing.

2.21.4 Environment Setup

The following tables list Digital's recommended PLC and GP communication settings.

■ Modicon Modbus

GP Setup		PLC Setup	
Baud Rate	19200 bps	Baud Rate	19200 bps
Data Length	8 bit	Mode	RTU (8)
Stop Bit	1 bit	Stop/Data	1 bit
Parity Bit	Even	Parity Bit	Even
Data Flow Control	ER Control	---	---
Communication Format (RS-232C)	RS-232C	---	---
Communication Format (RS-422)	---	---	---
Unit No.	1	Station Address	1



Caution

The top address of the system area cannot be set via the GP's OFFLINE area. Set it with the drawing software (GP-PRO/PBIII for Windows).



Important

- *These settings cannot be changed via the GP's OFFLINE mode. You must use the GP-PRO/PBIII software.*
- *E and K-tags cannot use the "Indirect" Setting.*
- *After the H-tag starts (is triggered), data cannot be read (out).*
- *After the S-tag starts (is triggered), data cannot be read (out).*
- *The Trend graph's group data display's PLC device designation cannot be made.*
- *D-Script 's Memory Copy and Offset Address features cannot be used.*
- *The Logging and Filing Data features cannot be used.*
- *2-Way Driver cannot be used.*







2.22 ORIM VEXTA

2.22.1 System Structure

The following describes the system structure for connecting the GP to ORIM VEXTA PLCs.

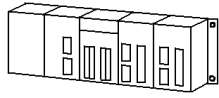
Reference The Cable Diagrams mentioned in the following tables are listed in the section titled "2.22.2 Cable Diagrams".

■ E1 Series (Link I/F)

CPU	Link I/F	Cable Diagram	GP
			
CPU11	MM01	RS232C (Cable Diagram 1)	GP Series

2.22.2 Cable Diagrams

The cable diagrams shown below and the cable diagrams recommended by ORIM VEXTA may differ, however, regardless of these differences, using Digital's recommended diagrams will not cause any operation problems.

Cable Diagram 1 (RS-232C)

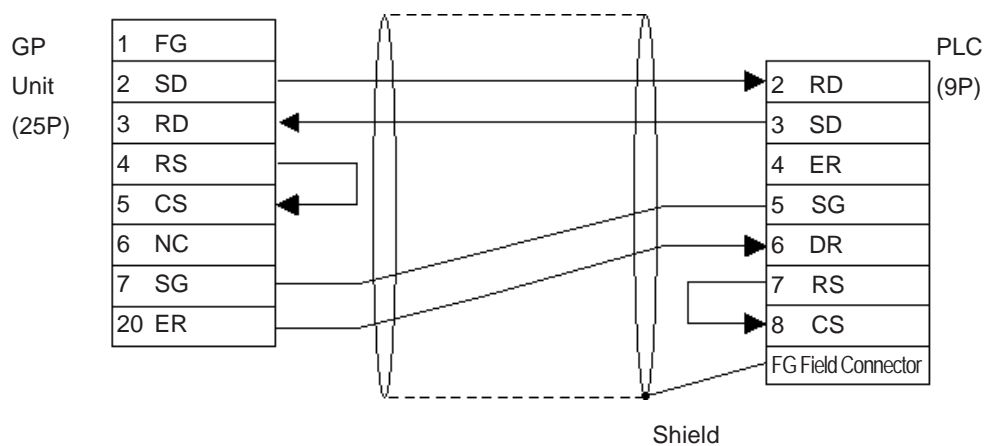









- You will need to make your own cable.
- When using an RS-232C cable, the cable must be no longer than 15 meters.

2.22.3 Supported Devices

The following describes the range of devices supported by the GP.

■ **E1 Series**

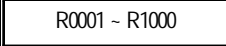
 Setup System Area here.

Device	Bit Address	Word Address	Particulars	
Input Register (I)	I000100 ~ I000815	I0001 ~ I0008		L/H
ON Event Input Register(IU)	IU00100 ~ IU00815	IU001 ~ IU008	*2	
OFF Event Input Register(ID)	ID00100 ~ ID00815	ID001 ~ ID008	*2	
Output Register(O)	O000100 ~ O000815	O0001 ~ O0008		
Analog Input Register(AD)	-----	AD001 ~ AD008	 *2	
Analog Output Register(DA)	-----	DA001 ~ DA008		
Position Register (M)	M000100 ~ M010031	M0001 ~ M100	*3	H/L
Speed Register Low(SL)	-----	SL001 ~ SL100	 *3	
Speed Register High(SH)	-----	SH001 ~ SH100	 *3	
Speed Register Raise(SR)	-----	SR001 ~ SR100	 *3	
Speed Register Decrease(SD)	-----	SD001 ~ SD100	 *3	
Universal Register(R)	R000100 ~ R100015	 R0001 ~ R1000		
Universal Double-Length Register(RD)	RD00100 ~ RD50031	RD001 ~ RD500	*3	
Base Resister (B)	B000000 ~ B000915	B0000 ~ B0009		
Current Motor Position(MP)	-----	MP001~MP008	 *3 *2	H/L
Current Motor Status(MP)	MS00100 ~ MS00815	MS001 ~ MS008	*2	L/H
SY Register(SY)	SY00100 ~ SY10015	SY001 ~ SY100	*1 *2	

*1 For further information about SY register, refer to ORIM VEXTA's Motion Controller E1 Series Operation manual.

*2 Data cannot be written to here.

*3 This device is 32 bit.

2.22.4 Environment Setup

The following lists Digital's recommended PLC and GP communication settings.

E1 Series

	GP Setup	PLC Setup ^{*2}
Baud Rate	9600 ^{*1}	9600
Data Length	8	8
Stop Bit	1	1
Parity Bit	None	None
Data Flow Control	ER Control	ER Control
Communication Format (RS-232C)	RS-232C	RS-232C (fixed)
Station No.	1(fixed)	-----
Checksum	-----	Yes
Designate Termination Code	-----	Yes
Protection	-----	No

*1 The maximum baud rate is 19200bps.

*2 < PLC Settings >

Use the MM01 Link unit's side face rotary switch and dip switch (8 positions.)

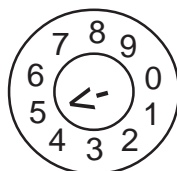

Rotary Switch

Setting	Baud Rate	Particulars
0	300	
1	600	
2	1200	
3	2400	
4	4800	
5	9600	Default Value
6	19200	
7 - 9	cannot be used	

Dip Switch

OFF	ON																																																						
	<table border="1"> <thead> <tr> <th>#</th> <th>Function</th> <th>OFF</th> <th>ON</th> <th>Default</th> <th></th> </tr> </thead> <tbody> <tr> <td>1</td> <td>Data length</td> <td>7 bit</td> <td>8 bit</td> <td>8 bit</td> <td>ON</td> </tr> <tr> <td>2</td> <td>Parity</td> <td>No</td> <td>Yes</td> <td>No</td> <td>OFF</td> </tr> <tr> <td>3</td> <td></td> <td>Odd</td> <td>Even</td> <td></td> <td>OFF</td> </tr> <tr> <td>4</td> <td>Stop Bit</td> <td>1bit</td> <td>2 bit</td> <td>1 bit</td> <td>OFF</td> </tr> <tr> <td>5</td> <td>Checksum</td> <td>No</td> <td>Yes</td> <td>Yes</td> <td>ON</td> </tr> <tr> <td>6</td> <td>Termination code</td> <td>No</td> <td>Yes</td> <td>Yes</td> <td>ON</td> </tr> <tr> <td>7</td> <td>Protection</td> <td>No</td> <td>Yes</td> <td>No</td> <td>OFF</td> </tr> <tr> <td>8</td> <td>(always OFF)</td> <td></td> <td></td> <td></td> <td>OFF</td> </tr> </tbody> </table>	#	Function	OFF	ON	Default		1	Data length	7 bit	8 bit	8 bit	ON	2	Parity	No	Yes	No	OFF	3		Odd	Even		OFF	4	Stop Bit	1bit	2 bit	1 bit	OFF	5	Checksum	No	Yes	Yes	ON	6	Termination code	No	Yes	Yes	ON	7	Protection	No	Yes	No	OFF	8	(always OFF)				OFF
#	Function	OFF	ON	Default																																																			
1	Data length	7 bit	8 bit	8 bit	ON																																																		
2	Parity	No	Yes	No	OFF																																																		
3		Odd	Even		OFF																																																		
4	Stop Bit	1bit	2 bit	1 bit	OFF																																																		
5	Checksum	No	Yes	Yes	ON																																																		
6	Termination code	No	Yes	Yes	ON																																																		
7	Protection	No	Yes	No	OFF																																																		
8	(always OFF)				OFF																																																		

- Important** • **The checksum and termination code must be set to ON.**
 • **When writing to PLC memory from GP, set the Protection(7) to OFF (No).**





2.23 FATEK

2.23.1 System Structure

The following describes the system structure for connecting to Fatek's Facon PLCs.

Reference The Cable Diagrams mentioned in the following tables are listed in the section titled "2.23.2 Cable Diagrams".

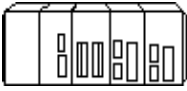
■ Facon FB 20MC (using CPU Direct Connection)

CPU	Cable Diagram	GP
		
20MC	Programming port on CPU (Cable Diagram 1)	GP Series

2.23.2 Cable Diagrams

The cable diagrams shown below and the cable diagrams recommended by FATEK may differ, however, regardless of these differences, using Digital's recommended diagrams will not cause any operation problems.

Cable Diagram 1 (RS-232C)

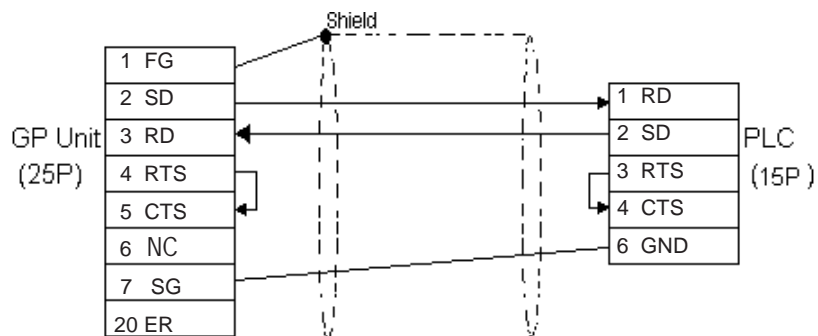

Please do not connect or disconnect the cable while the PLC and the GP are communicating.

2.23.3 Supported Devices

The following describes the range of devices supported by the GP.

■ Facon FB 20MC (using CPU Direct Connection)

 Setup System Area here.

Device	Bit Address	Word Address	Particulars	
Input points	X0 ~ X159	WX0 ~ WX144	*1	L/H
Output Relays	Y0 ~ Y159	WY0 ~ WY144		
Internal Relays	M0 ~ M1399	WM0 ~ WM1376		
Special Relays	SM1912 ~ SM2001	WSM1912 ~ WSM1976		
Step Relays	S0 ~ S999	WS0 ~ WS984		
Timer Registers	T0 ~ T255	----		
Counter Registers	C0 ~ C255	----		
Timer Registers	----	TMR0 ~ TMR255		
Counter Registers	----	CTR0 ~ CTR199		
Data Register	----	HR0 ~ HR3839	Bit 15	
Input Registers	----	IR3840 ~ IR3847	Bit 15 *2	
Output Registers	----	OR3904 ~ OR3911	Bit 15	
HSC Registers	----	HSC4096 ~ HSC4127	Bit 15	
Calendar Registers	----	RTC4128 ~ RTC4135	Bit 15	
Special Register	----	SR4136 ~ SR4167	Bit 15 *2	
Read-Only Registers	----	ROR5000 ~ ROR8071	Bit 15	

*1 Read Only for Word Devices.

*2 Read Only.

2.23.4 Environment Setup

The following table lists Digital's recommended PLC and GP communication settings.

■ Facon FB 20MC (using CPU Direct Connection)

	GP Setup	PLC Setup
Baud Rate (bps)	9600 (fixed)	-----
Data Length	7bits (fixed)	-----
Stop Bit	1bit (fixed)	-----
Parity Bit	Even (fixed)	-----
Data Flow Control	ER Control (fixed)	-----
Communication Format (RS-232C)	RS-232C (fixed)	-----
Unit No.	1-255	1-255
-----	-----	DSWBIT1 -> OFF
-----	-----	DSWBIT2 -> OFF



- **The PLC's settings must only use station numbers that are effective. (i.e. registered)**
- **The PLC's station number setting can be entered via the programmable controller's "Set Station No." setting area.**
- **Data Flow control must be set to " ER Control " from the GP's OFFLINE Setting Menu, or via the User's Screen Editor software.**



3 Memory Link Communication

Read this chapter if you are using the GP unit with the memory link communications.

This chapter explains one-to-one communication between the GP unit and equipment such as a personal computer or a one-board microcomputer which do not have their own protocols.

- Reference**
- For information about the extended mode, refer to the GP70 Series Memory Link Communication Protocol Manual.
 - For details, refer to the GP70 Series Memory Link Communication Protocol Manual for GP Ethernet I/F Unit (sold separately).

3.1 Setting Up Memory Link Communication

Data transmission between the GP and Host (PLC) are run according to the host's ladder logic program.

Reference Refer to the section titled "3.4 Sample Program".

The GP runs its screen display relying on the host's data write commands, which are based on the screen display's data send restrictions. And, the GP, following the host's Reading command, passes stored data over to the host. Communication occurs between the GP and host in this way, and normally, the initiative is held on the host side. Data transmission between the GP and PLC is aided by the memory area (System Area) prepared internally in the GP.

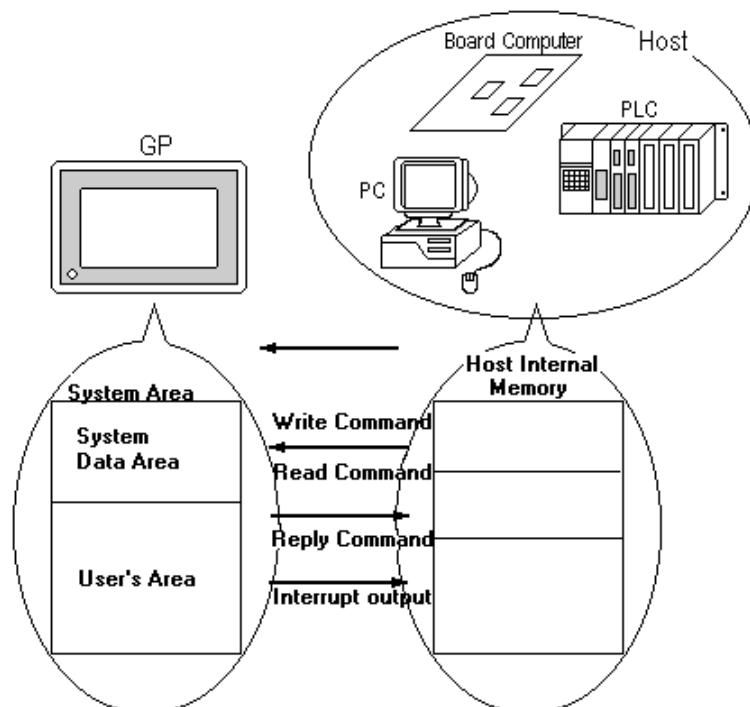

3.1.1 System Area

The System Area is the medium that allows data transmission between the GP and host. The System area is prepared internally in the GP; the GP runs the screen display based on the System Area data.

The System Area is 4096 words in size, organized as follows.

LS0	System Data Area
⋮	
LS19	Reading Area
LS20	
⋮	User's Area
⋮	
LS2032	Special Relays
⋮	
LS2047	Reserved
LS2048	
⋮	User's Area
LS2095	
LS2096	User's Area
⋮	
LS4095	

◆ **System Data Area**

This is the write area for data necessary to operate the GP screen control data and error information. The data write contents of each address is predetermined.

For more information, refer to 3-1-2 “Contents and Range of System Data Area”

◆ **User's Area**

This area is used for GP-Host data transmissions. On the host side, determine which GP address the data will be written to, and create a program to perform the data write operation. Plus, to display the written data on the GP side, another setup must be performed: Part or Tag Setup.

For the host to read data written with K-tags (Keypad Input) and T-tags (Touch Panel Input), a program must be made on the host side that reads data from the GP.



When using the Device Monitor feature, the User's Area (LS2096 to LS4095) will be reserved and cannot be used.

◆ **Special Relay**

This area is for setting up GP's various status information.



- Writing to System Address 13, using a T-tag, or similar method, causes an *interrupt* output to the host. On the host, read this one byte using a command like the BASIC INPUT\$ instruction, to call various subroutines which depend on the value, thus greatly simplifying the program.

- When specifying an address bit, enter the bit position (00~15) after the word device.

E.g. When specifying bit 02 of User's Area address 20:

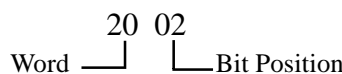

◆ **Reserved**

Please do not use this area. It is only for GP's internal use. If you use this area, the GP will not operate properly.

3.1.2 Contents and Range of System Data Area



When you wish to turn the GP's display OFF, use the Screen Display ON/OFF bit. Do not use the Control area's Backlight OFF bit. Be aware that this feature's system Data Area settings and range used during Memory Link Communication will differ from the settings used with Direct Access Communication.

Address	Detail	Function	Bit	Particulars			
1	Status *8		0, 1	Reserved			
			2	Now Printing *1			
			3	Writes a set value *2			
			4 ~ 7	Reserved			
			8	K-tag entry error *3			
			9 ~ 15	Reserved			
2	Error Status Each bit changes according to the GP error function. When an error occurs, the corresponding bit will turn on. * A bit that has turned on remains on until the power is turned off and back on, or until RUN mode is re-entered from OFFLINE mode or details and the handling process about the Error Status contents, refer to the Section 1-1-4.		0, 1	Unused			
			2	System ROM/RAM			
			3	Screen Memory Checksum			
			4	SIO Framing			
			5	SIO Parity			
			6	SIO Overrun			
			3			7, 8	Unused
						9	Initialization of Internal Memory Checksum Necessary
						10	Timer Lock Error
						11 ~ 15	Unused
4	Clock Data (Year)	"Year / Month / Day / Hour / Minute" Data is stored in BCD's 2digits. (E. g.) 98/02/01 17:15	0 ~ 7	Stores the last 2 digits of the Calendar year as 2 BCD digits			
5	Clock Data (Month)		8 ~ 15	Unused			
6	Clock Data (Day)		0 ~ 7	Stores 01 to 12 (Month) as 2 BCD digits			
			8 ~ 15	Unused			
7	Clock Data (Hour)		0 ~ 7	Stores 00 to 31 (Day) as 2 BCD digits			
			8 ~ 15	Unused			
8	Clock Data (Minute)		0 ~ 7	Stores 00 to 23 (Hour) as 2 BCD digits			
			8 ~ 15	Unused			
10	Interrupt Output (Touch OFF)	If you Write in word data, the bottom 8 bits will be output as an interupput code after touching OFF. However FFh will not be output.	0 ~ 7	Stores 00 to 59 (Minute) as 2 BCD digits			
11	Control *9		8 ~ 15	Unused			
			0	Backlight *4			
			1	Buzzer ON			
			2	Starts Printing			
			3	Reserved			
			4	Buzzer *5 --- 0:enabled 1: disabled			
			5	AUX Output --- 0:enabled 1: disabled			
			6	Interrupt Output when touching panel to turn the display ON. (Interrupt Code:FFh) 0: Disabled 1: Enabled *13			
			7	Reserved			
			8	VGA display *6 --- 0: Disabled 1: Enabled			
			9, 10	Reserved			
			11	Hard copy output *12 --- 0: Enabled 1: Disabled			
			12 ~ 15	Reserved			

Address	Detail	Function	Bit	Particulars
12	Screen Display *10 ON/OFF	FFFFh : Screen clears almost immediately 0h: Screen turns ON		
13	Interrupt Output *11	Using a Touch Tag or other method to write absolute value data from GP causes an output of the interrupt code using the contents of the bottom 8 bits (Will not output FFh)		
15	Screen Display No.	Write the Screen No. in binary to change the screen display	0 - 14	Screen change number, 1 to 8999. (1 to 1999 when using BCD input)
			15	Forced Screen Change
16	Window Control *7		0	Display -- 0: OFF 1: ON
			1	Changing the order of window overlapping -- 0: Possible 1: Not Possible
			2 - 15	Reserved
17	Window Registration No. *7	Global Window registration number selected indirectly (BIN/BCD)		
18	Window Display Position *7 (X-coordinate)	Global Window display position reached indirectly (BIN/BCD)		
19	Window Display Position *7 (Y-coordinate)			

- *1 *Changing to OFFLINE mode in the middle of printing can cause a disordering of the Print output.*
- *2 *Every time a value is written with the K-tag or Keypad Input Display, the bit is reversed.*
- *3 *If an (input value range) Error has been set for the K-tag data being entered, and a value outside the allowed range is entered, the bit lights. If, however, a value is entered that is within the Error range, or if the display screen is changed, this bit will turn OFF.*
- *4 *With the GP series except GP-477R, GP-470, and GP-870 series units, the backlight turns OFF when this bit is ON(LCD display does not change) and turns ON when the bit is OFF.*

When the Control area's Backlight OFF bit turns ON, only the backlight will turn OFF, however, the LCD display will remain ON and all touch switches set up on the display can still be used. Use the Screen display ON/OFF bit to actually turn the screen display OFF.
- *5 *Control Bit 1 (Buzzer On) outputs as shown below.*
Buzzer Sound While Control Bit1 is on, the GP internal buzzer is activated.
AUX Output While Control Bit 1 is on, the AUX buzzer output is activated.
- *6 *When using GP-570VM, the entire screen becomes a VGA display when this bit is on. Pressing the screen options position during a VGA display turns this function off.*
- *7 **Reference** *For more about windows, refer to "2.26 U-tag (Window Display)" GP-PRO/PBIII for Windows Tag Reference Manual.*

*8 Monitor, in bit units, only the necessary bits.

Since reserved bits may be used for GP system maintenance, etc., their ON/OFF status is not defined.

*9 Be sure to turn all reserved bits OFF since they may be used for GP system maintenance, etc.

*10 After the System Data Area's "Screen Display ON/OFF" bit is set to turn the display OFF, simply touching the screen will turn the display ON again.

*11 Do not write control codes 00 to 1F to word address 13. It may terminate data communication.

*12 Turning ON bit 11(Hard Copy Output) in the Control Area will cancel the current printing of the display's hard copy.

- After printing is cancelled, bit 11, however, will not turn OFF automatically. Therefore, after checking the Status Area's Now Printing bit, turn off the Control Area's bit 11.
- While bit 11 in the Control area is turned ON, hard copy cannot be created. If you cancel printing before it is completed, printing will stop after the last line data on the panel's current display has been output. Data already input in the printer buffer's memory will not be deleted.

*13 Interrupt output when touching the panel to turn the display OFF to ON.

- Only when the display is turned ON by touching the panel, interrupt output will be operated.
- When using GP-H70, interrupt output will not be operated if the display is turned ON by the Operation Switch on the rear side.



- Addresses 0, 2, 9, 10, 14 are reserved areas. Do not write data to this area.
- When addresses 3, 12, 13, 15 are utilized for System Control, displays that depend on tags do not function.
- When addresses 12, 13, 15 are used to control word units, bit write cannot be performed.
- Writing FFFFh to address 12 causes the screen display to erase within moments. When you wish to erase the screen using the STANDBY MODE TIME entered in GP's INITIALIZE setup, write 0000h in address 12.
- Do not write the control code 00~1F in address 13. Data transmission may become impossible.

3.1.3 Special Relay

The structure of the Special Relay is as follows:

◆ **Reserved**

The Reserved address value is undefined. Do not use this area.

2032	Common Relay Information
2033	Base Screen Information
2034	Reserved
2035	
2036	1 Second Binary Counter
2037	Tag Scan Time
2038	Reserved
2039	Tag Scan Counter
:	Reserved
:	
2047	

◆ **Common Relay Information (2032)**

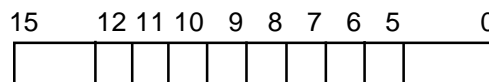

Bit	Contents
0	Reserved
1	Remains ON from when a screen change (base, window) occurs until the tag scan is complete.
2	ON only in the middle of an SIO error developing.
3	ON when displaying the Initial screen after powering up.
4	Always ON
5	Always OFF
6	Turns ON when backup SRAM data has been deleted (Only for GP's equipped with backup SRAM).
7	Turns ON if a BCD error occurs while D script is being used. For more information about D script, refer to the Tag Reference Manual's section 3.1 "D script".
8	Turns ON if a zero division error occurs while D script is being used.
9	Filing data. Turns ON if the data is not transferred to Backup SRAM.
10	Filing data transfer is triggered by the Control Word Address. Turns ON if the data can not be transferred from PLC to SRAM. Also data transfer between PLCs is triggered by the Filing Data Display. Turns ON if the data is not transferred from PLC to SRAM only when the transfer complete bit address is used.
11	Filing data. Via transfer data to and from SRAM to LS area, via Filing Data Display.
12	When using D-script, turns ON if a communication error occurs when the function memcpy () is used, or reading the data from designated Address Offset. Turns OFF when data read is normally completed.
13-15	Reserved

Reference For more information about the D-script, refer to the Tag Reference Manual “3.1 D-Script/Global D-Script”.

◆ **Base Screen Information (2033)**

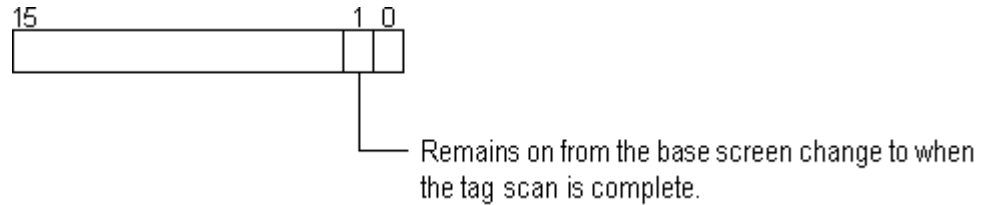

◆ **1 Second Binary Counter (2035)**

Begins counting in one second intervals after the GP's power is turned ON. The data is binary.

◆ **Tag Scan Time (2036)**

The time it takes to prepare all the tags setup on the display screen. The data is stored as binary, millisecond units. The data renews itself at the point when preparation for all the object tags is complete. The data's default value is 0. It is accurate within + 10ms.

◆ **Tag Scan Counter (2038)**

Counts until the all the tags setup on the display screen have completed their preparations. The data is binary.



The Special Relay is not write protected. Do not turn this Relay's data ON or OFF using tags or other method.



3.2 Cable Diagrams

Explains the connection between the GP and host.

3.2.1 RS-232C Communication

When using an RS-232C cable, there are two types of control formats: DTR (ER) Control and XON/XOFF Control. The GP-Host connection for each type is illustrated below.

■ DTR (ER) Control

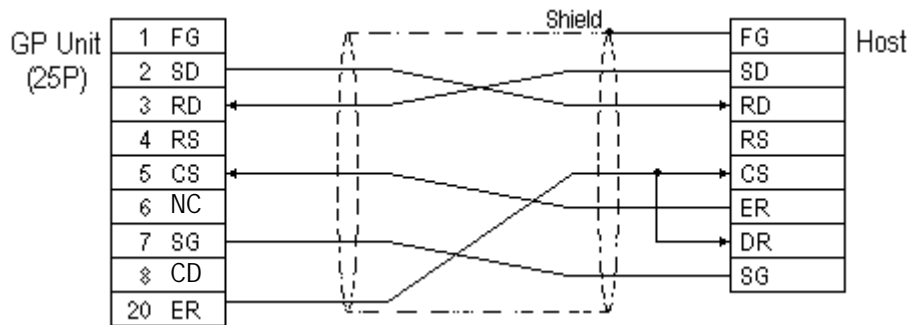

Set the host's control software so that the host will not transmit data to the GP when the GP's ER is turned OFF.

■ XON/XOFF Control

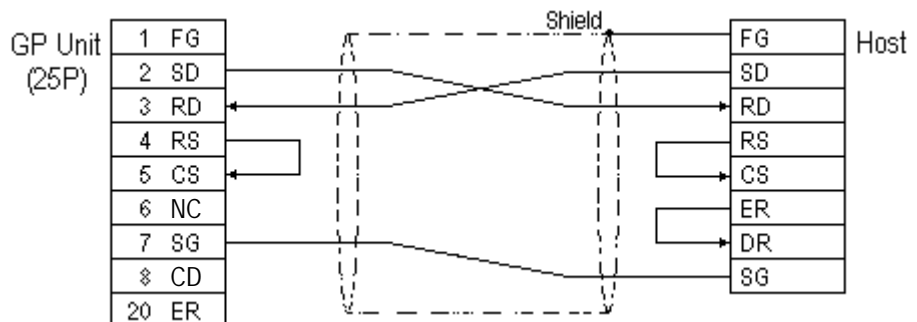

- Depending on the host, the RS-232C connector's shape, pin numbers and corresponding signal names may differ. Be sure to follow the host interface specifications.
- The maximum cable length is 15m.

3.2.2 RS-422 Communication

When using an RS-422 cable, there is only the XON/XOFF Control. The various GP-Host connections are illustrated below.



- Insert a termination resistor between RDA-RDB.
- For a 24AWG line, use a twist pair cable with a static electrical capacity of 50pF/m, and a standard characteristic impedance of 100Ω.



- The maximum length of the cable is 600m.
- Depending on the connected Host, the connection method and termination resistance differs.

- When using Digital's RS-422 connector terminal adapter, GP070-CN10-0

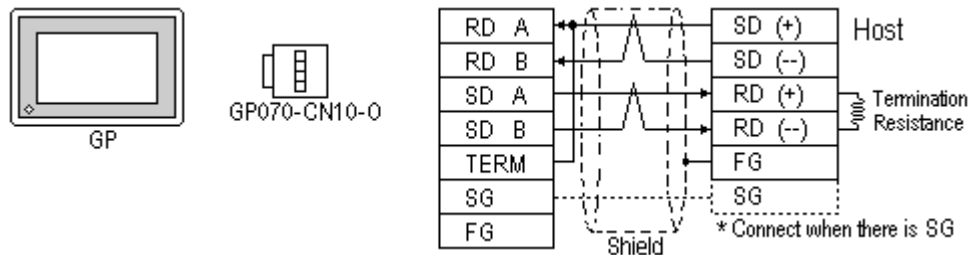

As a result of connecting GP070-CN10-0's RDA and TERM, a 100Ω termination resistance is inserted between RDA—RDB on the GP.

- When using Digital's RS-422 Cable, GP230-IS11-0

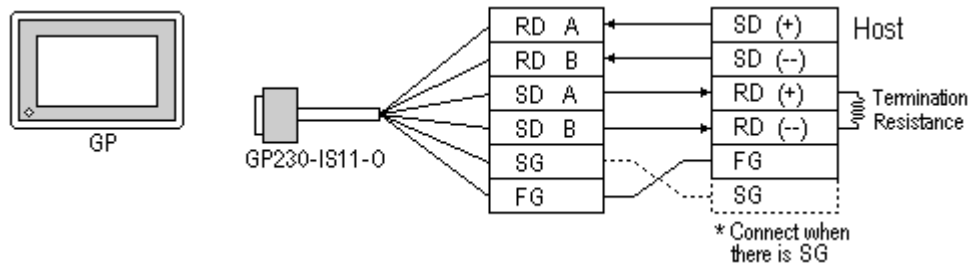

When connecting the #9 and #10 pins in the GP Serial I/F, a termination resistance of 100Ω is added between RDA and RDB.

- When making your own cable connections

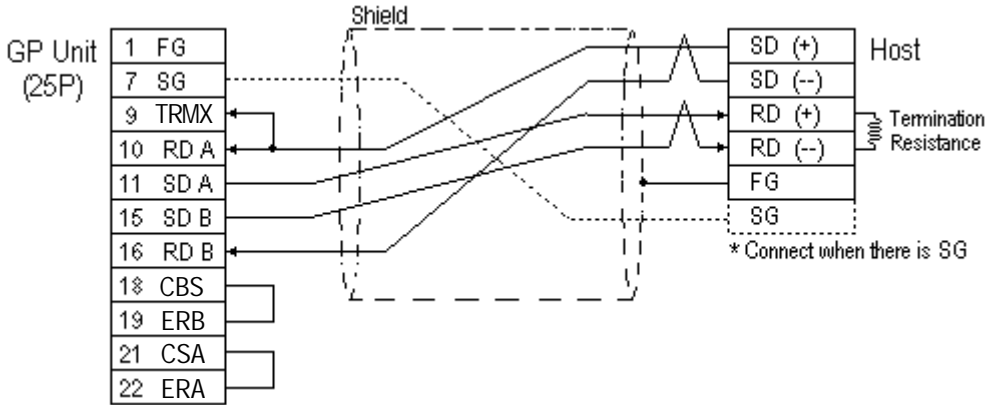

Note: When connecting the #9 and #10 pins in the GP Serial I/F, a termination resistance of 100Ω is added between RDA and RDB.



3.3

Memory Link Command

The communications protocol shows the format of data transferred between the host computer and the GP and the procedure for this data transfer. The communications protocol for the GP is classified into the following modes according to the application and the data processing capability of the host computer.

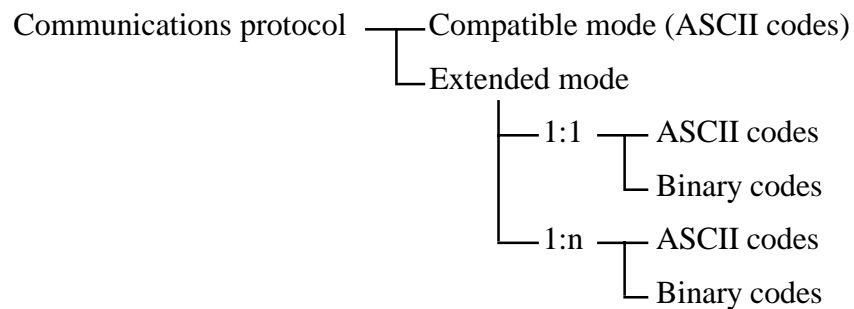

■ Compatible mode

In this mode, only writing to the system area (Esc W) and reading from the system area (Esc R) commands are performed using communications protocol. The compatible mode is basically a teletype protocol using ASCII codes. Therefore, the load for controlling the communications on the host computer is decreased. In contrast, the reliability of the transmitted and received data is relatively low.

■ Extended mode

This mode is a protocol which supports not only commands for writing to and reading from the system area, but also drawing commands. The extended mode is a communications protocol compatible with the multi-drop connection between the host computer and the GP. To improve the reliability of communications data, you may specify whether sum check codes are used or not and whether ACK and NCK are used or not. The ASCII codes and the binary codes are dependent on the development of the software environment. Select whichever codes are appropriate.



Note:

Only the commands in the compatible mode are covered in this manual.

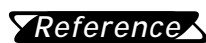

Reference

For the extended mode, Refer to The Memory Link Communications Manual for the GP70 Series (sold separately).

GP-Host data transmissions are run as described for each command below.

- Read command** This command reads data from the setup System Area address.
- Reply command** This command responds to the Read command and passes this data from the GP to the Host.
- Write command** This command writes the data to the setup System Area address.
- Interrupt output** Using a touch tag or other method to write data to System Data Area address 13 causes an interrupt code in the contents of the bottom 8 bits, which is then output to the Host side.



When using double-words (32-bit data), the upper and lower data are set up as follows:

0	H (High)	(Upper)
1	L (Low)	(Lower)



Send the read command from the Host after receiving the reply command.

<Example> Data communication between the Host computer and the GP

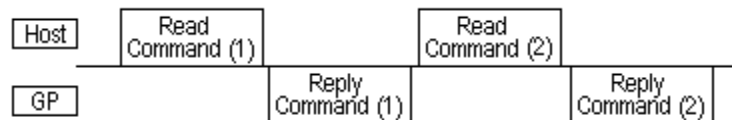

Send the read command (2) after receiving the reply command (1).

When the read command is sent continuously without waiting for the reply command, a system error may be generated two or three hours later.

3.3.1 Read Command

The contents of the Read command are as follows:

ESC (1Bh)	Start Code
R (52h)	Read command
Address (4 bytes)	
Read Word Number (4 bytes)	
CR (0Dh)	Return

E.g. Reads 2 words of hexadecimal data from System Area address 100.

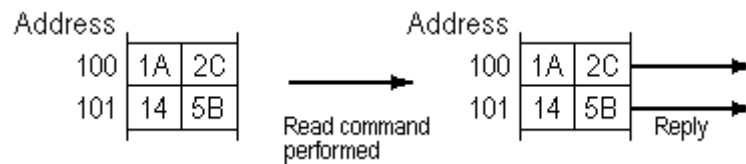

Read Command

Esc	R	0	0	6	4	0	0	0	2	CR
Start Code	Read Command	Address 100				Read Word Number 2				Return



The Address and Read Word Number can be entered in ASCII Code.

3.3.2 Reply Command

The contents of the Reply command are as follows:

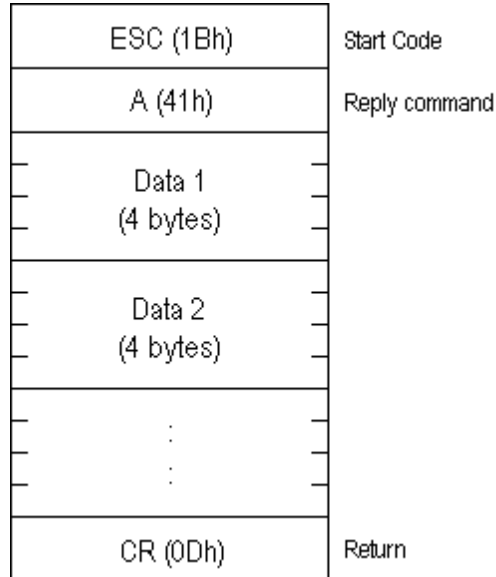

E.g. Read 2 words of hexadecimal data from System Area address 100.

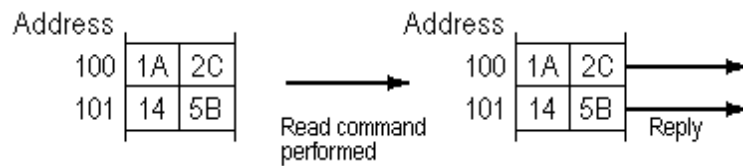

Reply Command

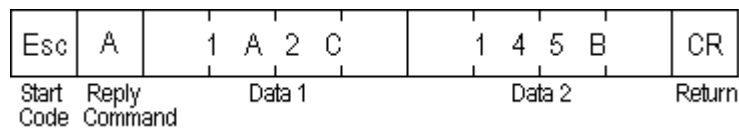

- The response command is output automatically from the GP in answer to the read command received.
- The Address and Data can be entered in ASCII Code.
- Data is read, in order, from the setup address.

3.3.3 Write Command

The contents of the Write command are as follows:

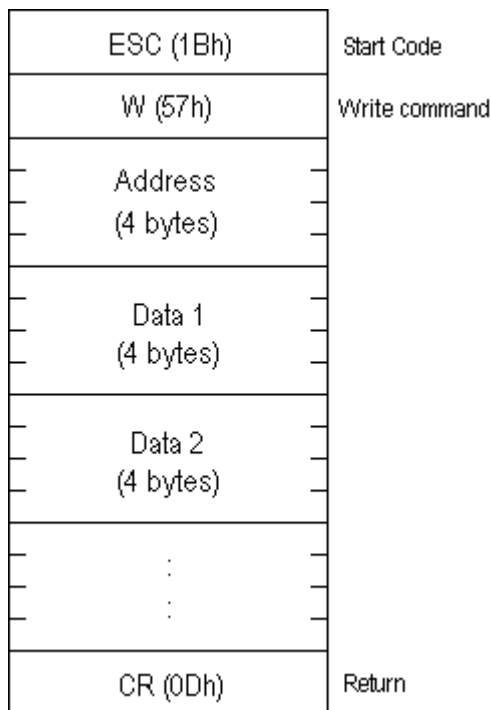

E.g. Writes hexadecimal data 1A2C and 145B from System Area address 100.

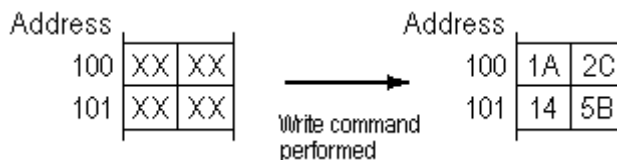

Write Command

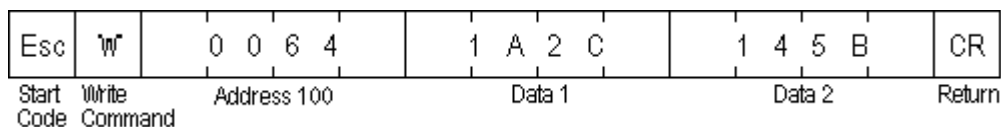

- The *Address* and *Data* can be entered in ASCII Code.
- Data is written, in order, from the setup (start) address.
- In Compatible mode, the Reply command does not return.
- If you keep send the Write command to GP constantly, be aware that GP might fail to update the screen data.

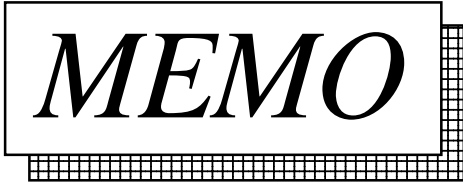

3.4 Sample System

This section provides examples of the Host program and GP tag setup which are necessary for data transmissions between the GP and Host. Plus, when the tag setup below is run with the sample program, it demonstrates a GP screen change.

Use the following steps to create the screens shown below.

When the [Motor ON], [Motor OFF], [Display], or [Error] switch is pressed, that switch's respective interrupt code is output to the host system, starting the following operations (T-tag).

Switch Explanation

- [Motor ON] Starts the motor to supply 50% of the sediment into the sedimentation tank.
- [Motor OFF] Stops the motor.
- [Display] "50% of the sediment is being supplied to the sedimentation tank."
- [Error] "Only 20% of the sediment has been supplied to the sedimentation tank."

System Example

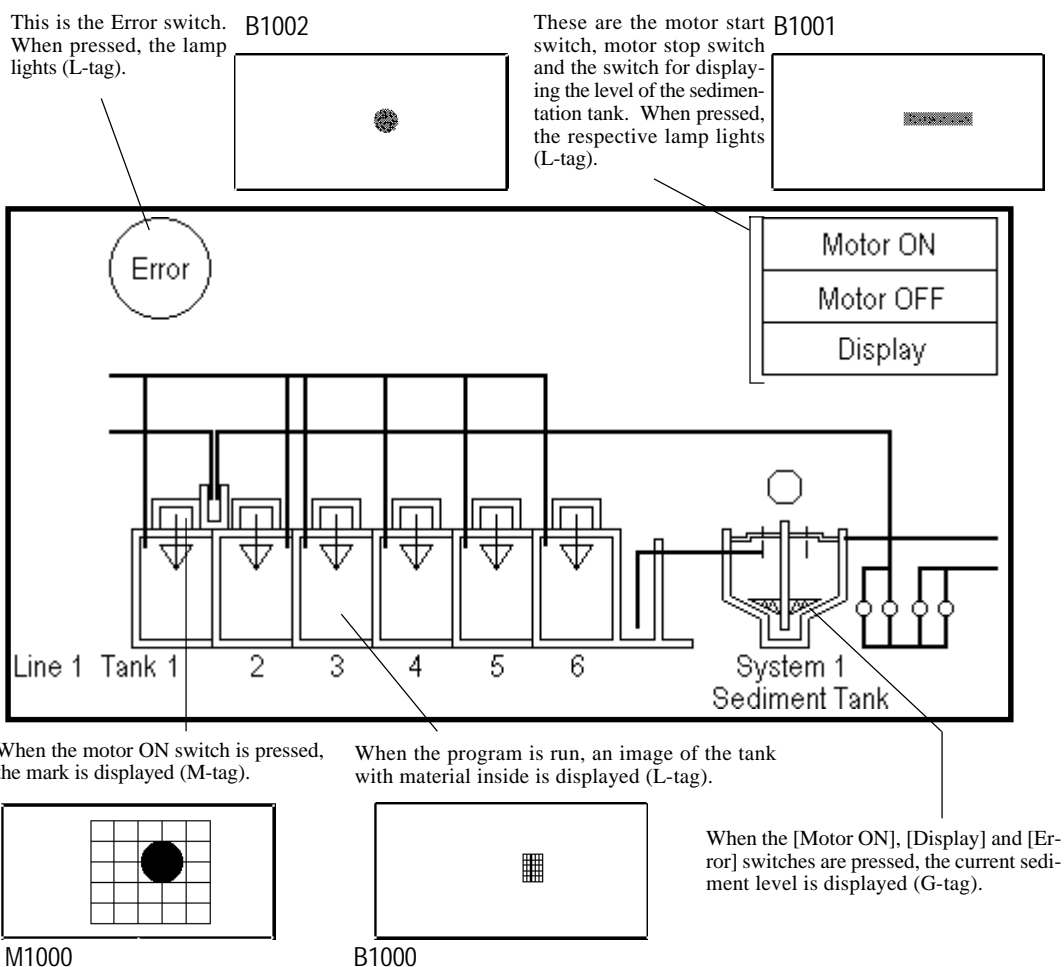

■ Screen Creation

(1) Use the GP-PRO/PBIII for Windows software to create the screens.

B1

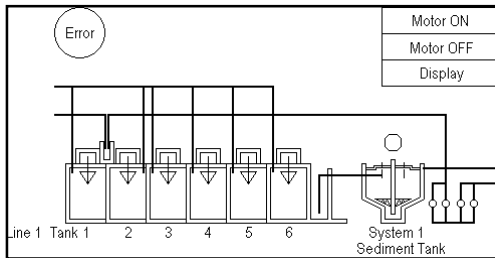

This screen is displayed when the GP is operating.

B1000

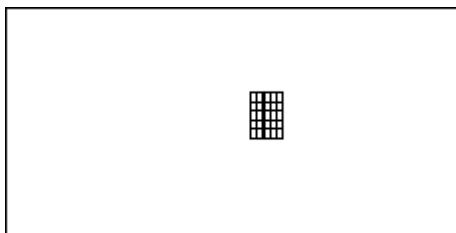

This screen represents the material to be put into the aeration tank.

B1001

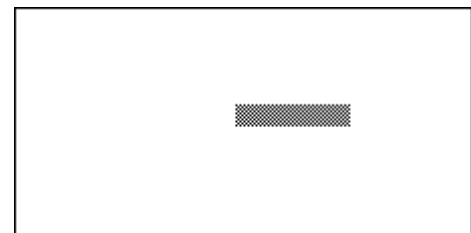

This screen shows the [Motor ON], [Motor OFF] and [Display] lamp's ON pattern.

B1002

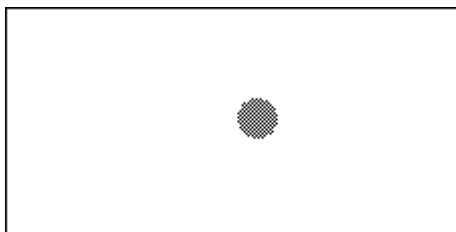

This screen shows the [Error] switch's ON pattern.

M1000

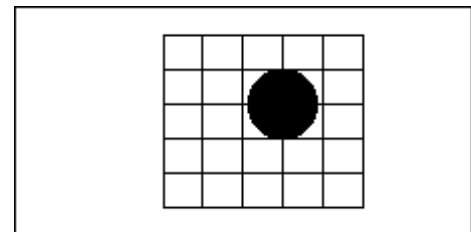

This screen shows the mark displayed when the motor is started.

(2) Use the GP-PRO/PBIII for Windows software to setup Tags

◆ Tag Setup Example

T-tag List

File No.	Tag Name	Op. Mode	Word Addr	Word Write	Fixed No.	Reverse Display	Starting point coordinate	Ending point coordinate	Details
B1	T1	Word	13	Word Set 16 bit	0031	On	Coordinates entered will vary according to screen being used.		Motor ON
B2	T2				0032				Motor OFF
B1	T3				0033				Display
B1	T4				0034				Error

L-tag List

File No.	Tag Name	Display Mode	Bit Addr	File Access	Direct Access File No.	Delete	Display coordinates	Details		
B1	L1	0 --> 1 Erase Operation On	002000	Direct Access	B1000	On	Coordinates entered will vary according to screen being used.	Tank 1		
B1	L2		002001					Tank 2		
B1	L3		002002					Tank 3		
B1	L4		002003					Tank 4		
B1	L5		002004					Tank 5		
B1	L6		002005					Tank 6		
B1	L11		002100					"Motor ON" Reverse		
B1	L12		002101					"Motor OFF" Reverse		
B1	L13		002102					"Display" Reverse		
B1	L14		002103					"Error" Reverse		
					B1001					
					B1002					



When you wish to display L1~6 (L-tag) at the same time, turn all bits in address 20 ON.

M-tag List

File No.	Tag Name	Bit Addr	Display Mode	Color Attr. 0	Color Attr. 1	Magnify	File Access	Direct Access File No.	Display coordinates	Details
B1	M1	002200	Displays On/Off	Fg Clr:Black Bg Clr: Black Blink: Off	Fg Clr:White Bg Clr: Black Blink: Off	1 X 1	Direct Access	M1000	Coordinates entered will vary according to screen being used.	Motor 1
B1	M2	002201								Motor 2
B1	M3	002202								Motor 3
B1	M4	002203								Motor 4
B1	M5	002204								Motor 5
B1	M6	002205								Motor 6



When you wish to display L1~6 (M-tag) at the same time, turn all bits in address 20 ON.

G-tag List

File No.	Tag Name	Word addr	Data Type	Data Format	Code	Bit Length	Input Code	Color Attr.	Graph type	Dir.	Tiling Pttrn.	Alarm	Starting point coordinate	Ending point coordinate	Details
B1	G1	0023	Relative Value	BCD	+	16	None	Fg: White Bg: Black Blink: Off	Trend Graph	Up	2	Off	Coordinates entered will vary according to screen being used.		Sediment Tank

◆ **Address Map**

Tags used in the Sample program are allotted to their corresponding address as follows.

T-tag —> Address 13

Writing data to Address 13 (Interrupt) causes an output of the bottom 1 byte code from the RS-232C port. For this reason, the T-tag uses word write.

- Motor ON (T1)..... word write 0031 to address 13
- Motor OFF (T2) word write 0032 to address 13
- Display (T3) word write 0033 to address 13
- Error (T4) word write 0034 to address 13

L-tag —> Address 20, Address 21

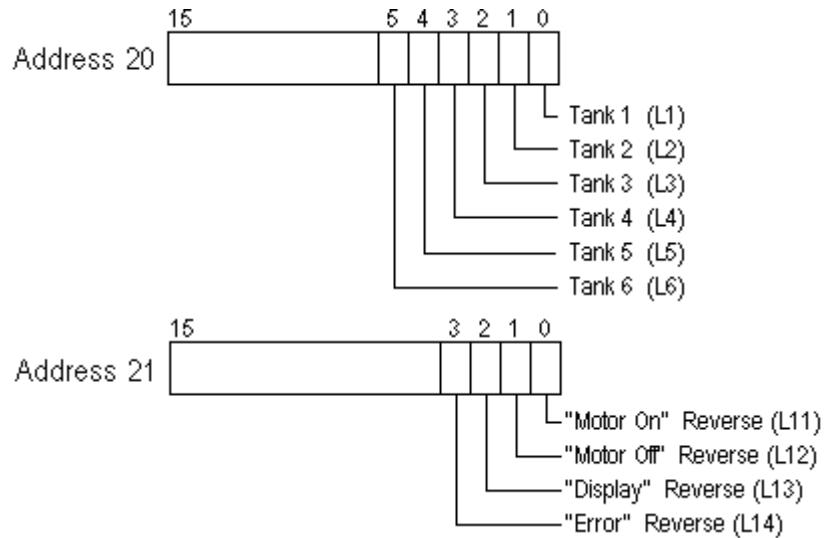

M-tag —>Address 22

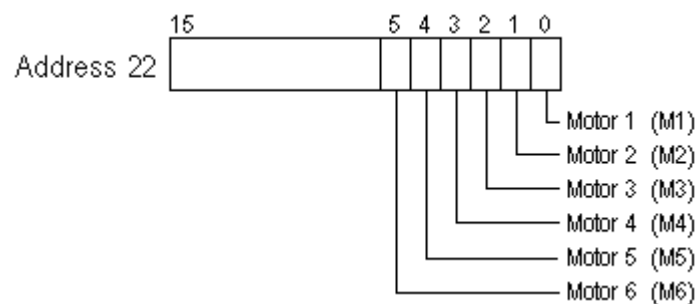

G-tag —> Address 23

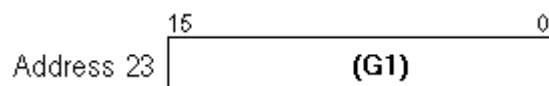

- (3) The host unit's company creates the program for data transfer between the GP and the host.

◆ Sample Program

E.g. If an IBM PC/AT-compatible machine and the C language are used:

```

/*****
/*
/* GP series   Sample program for memory link communications
/*
/*****

#include<stdio.h>
#include<dos.h>
#include<string.h>
#include<stdlib.h>
#include<conio.h>

#define data_size_str2      20      /*The data size of str2 is 20 bytes*/
#define data_size_wr_data  24      /*The data size of wr_data is 24 bytes*/

#define serial_port_BIOS    0x14    /*PC serial port BIOS*/
#define serial_port_number  0x00    /*Serial port number used*/
#define serial_port_INT     0xE7    /*The serial port is initialized.*/
#define serial_port_parameter 0xE7  /*9600bps,8bit,stopbit;1,parity;none*/

#define get_status          0x03    /*The status of the serial port is acquired.*/
#define serial_port_write   0x01    /*The serial port is written.*/
#define serial_port_read    0x02    /*The serial port is read out.*/

#define status_bit_6000     0x60000 /*Port status bits 13 and 14*/
#define status_bit_0020     0x0020  /*Port status bit 5*/

/*****
/*      Communications settings for the SIO
/*****
void open_SIO (void);          /*Communications settings for RS232C*/

/*****
/*      Acquisition and identification of port status
/*****
int  err_status (void); /*The port status is acquired.*/
void write_ready (void); /*The transmission buffer register and the transmission register statuses are acquired.*/
int  read_ready (void); /*Confirmation of data set status*/

/*****
/*      Writing data
/*****
void write_data (char wr_data); /*The data is written to the registers.*/
void write (char *wr_data);     /*The data is written to the GP.*/

/*****
/*      Reading data
/*****
int  read_data (void);          /*The data is read from the GP.*/
void change_screen (int interrupt_data); /*The received data in an interruption from the GP is identified.*/
int  read (void);              /*The received data in an interruption from the GP is read.*/

/*****
/*      Confirmation of key entries
/*****
int  kbhit (void);

/*****
/*      Global variables
/*****
int  interrupt_data,port_status+;
char *str2;

```

```

void main (void)
{
    int no_data;
    str2 = (char*) malloc (sizeof (char) *data_sezi_str2); /*The memory for str2 is secured.*/
    char *wr_data = (char*) malloc (sizeof (char) *data_size_wr_data);
                                     /*The memory for wr_data is secured.*/
    open_SIO ();          /*Communication settings for RS232C*/
    wr_data = "\x1bW000F0001\x0d\x0"; /*0x1 is written to address 15: screen number 1 setup*/
    write (wr_data);
    wr_data = "\x1bW0014003F\x0d\x0";
                                     /*0x3F is written to address 20: Materials are put into aeration tanks Nos. 1 to 6.*/
    write (wr_data);
    /******
    /* The data reception from the GP is identified.          */
    /* If the Write key is pressed, the execution is completed. */
    /******
    while (1)
    {
        no_data = read ();
        if (no_data == 1) /*If there is any key entry, no_data=1.*/
        {
            break;
        }
        else
        {
            wr_data = str2;
            write (wr_data);
        }
    }
    getch ();          /*The codes for keys are removed from the key buffer.*/
    free (wr_data);    /*The memory area for wr_data is freed up.*/
    free (str2);       /*The memory area for str2 is freed up.*/
}

/*The transmission buffer register status and the transmission register status are acquired.*/
void write_ready (void)
{
    int err6000;

    err6000 = 0;
    while (status_bit_6000 != err6000)
    {
        err6000 = err_status () & status_bit_6000;
    }
    return;
}

/*Confirmation of data set status*/
int read_ready (void)
{
    int no_data,err0020;

    err0020 = 0;
    while (status_bit_0020 != err0020)
    {
        err0020 = 344_status () & status bit_0020;
        if (kbhit ()) /*Confirms whether there is a key entry or not.*/
        {
            no_data = 1; /*If there is a key entry, no_data=1.*/
            break; /*The program is terminated.*/
        }
    }
}

```

```

    }
    return (no_data);
}
/*Data is written to the GP.*/

void write (char *wr_data)
{
    while (*wr_data != '\0')    /*The data is written until it becomes NULL.*/
    {
        write_ready ();
        write_data (*wr_data);
        wr_data++;    /*The address pointed to by the pointer is incremented.*/
    }
    return;
}
/*****
/*      The interrupt data received from the GP is confirmed.      */
/*      The data is written to addresses 20, 21, 22, and 23.      */
*****/
void change_screen (int interrupt_data)
{
    switch (interrupt_data)
    /*If interrupt_data is 1, 0x1 is written to address 21, 0x3F to address 22, and 0x50 to address 23.*/
        case 1: str2 = "\x1bW00150001003F0050\x0d\x0a";
            break;

    /*If interrupt_data is 2, 0x2 is written to address 21, 0x0 to address 22, and 0x0 to address 23.*/
        case 2: str2 = "\x1bW0015000200000000\x0d\x0a";
            break;

    /*If interrupt_data is 3, 0x4 is written to address 21, 0x0 to address 22, and 0x50 to address 23.*/
        case 3: str2 = "\x1bW001500004000000050\x0d\x0a";
            break;

    /*If interrupt_data is 4, 0x8 is written to address 21, 0x0 to address 22, and 0x20 to address 23.*/
        case 4: str2 = "\x1bW0015000800000020\x0d\x0a";
            break;

    /*If interrupt_data is other than 1 to 4, NULL is written.*/
        default : str2 = "\0";
            break;

    {
        return;
    }
}
/*****
/*      The interrupt data received from the GP is read.      */
/*      Reading is performed until the interrupt_data becomes other than NULL.      */
*****/
int read (void)
{
    int no_data;
    do
    {
        no_data = read_ready (); /*Confirmation of data set status*/
        if (no_data == 1)    /*If there is a key entry, no_data=1.*/
        {
            break;
        }
        else
        {

```

```

        read_data ();    /*The data received from the GP is read out.*/
        change_screen (interrupt_data); /*The data received from the GP is identified.*/
    }
} while (*str2 == '\0');
return (no_data);
}
/*Communications settings for RS232C*/

void open_SIO (void)
{
    union REGS regs ;
    regs.x.dx = serial_port_number;
    regs.h.ah = serial_port_INT;
    regs.h.al = serial_port_parameter;
    int86 (serial_port_BIOS,&regs,&regs);
    return;
}

/*The port status is acquired.*/
int err_status (void)
{
    union REGS regs;
    regs.x.dx = serial_port_number;
    regs.h.ah = get_status;
    int86 (serial_port_BIOS,&regs,&regs);
    port_status = regs.x.ax;
    return (port_status);
}

/*The data is written to the registers*/
void write_data (char wr_data)
{
    union REGS regs;
    regs.x.dx = serial_port number;
    regs.h.ah = serial_port_write;
    regs.h.al = wr_data;
    int86 (serial_port_BIOS,&regs,&regs);
    return;
}

/*The data is read from the GP*/
int read_data (void)
{
    union REGS regs;
    regs.x.dx = serial_port_number;
    regs.h.ah = serial_port_read;
    int86 (serial_port_BIOS,&regs,&regs);
    interrupt_data = regs.h.al;
    return (interrupt_data);
}

```



Note: The availability of `open_SIO (void)`, `err_status (void)`, `write_data (char wr_data)`, and `read_data (void)` will depend on the models used. If the program is written on a personal computer that is not IBM -compatible, it must be modified in order to be used.

(4) After screen data is transferred to the GP, display (operation) can begin.

◆ GP Run Screen

GP Screen (Before running program)

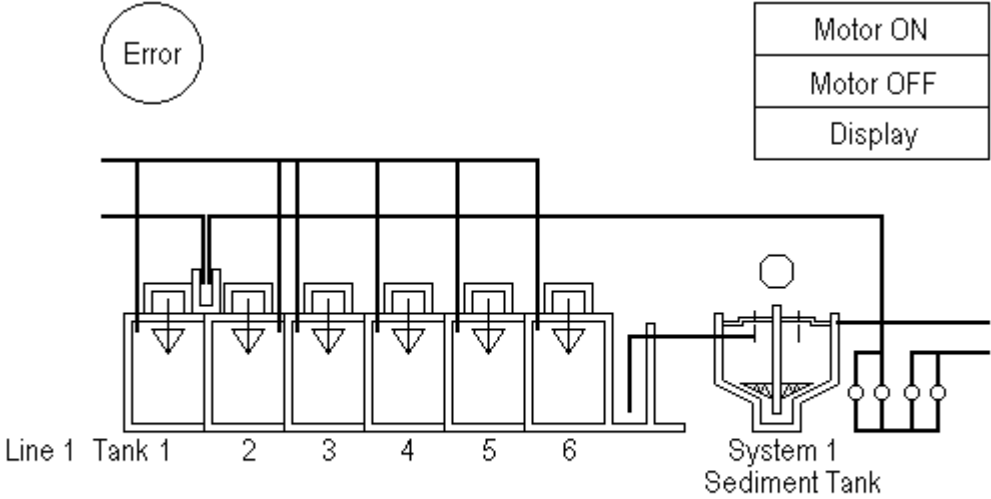

Run the Program

GP Screen (After running program)

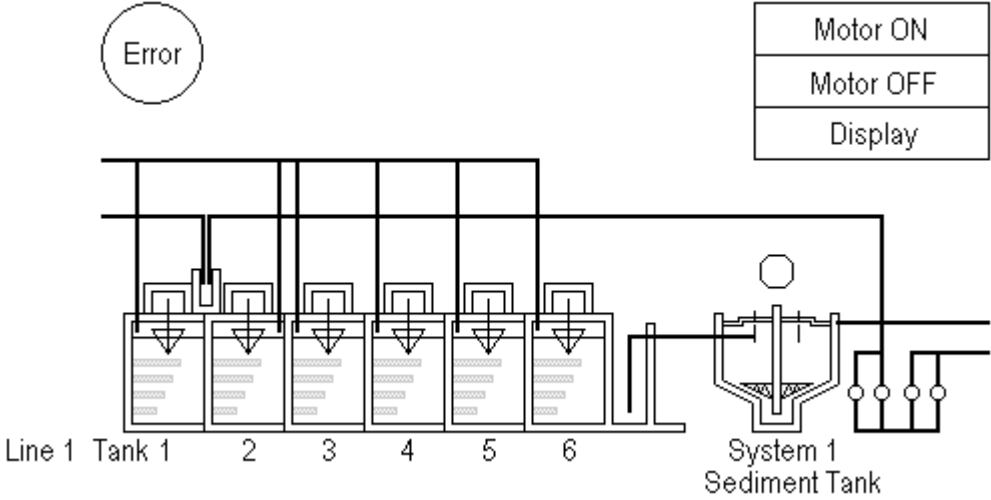

Six Libraries  appear in the No. 90 screen display.

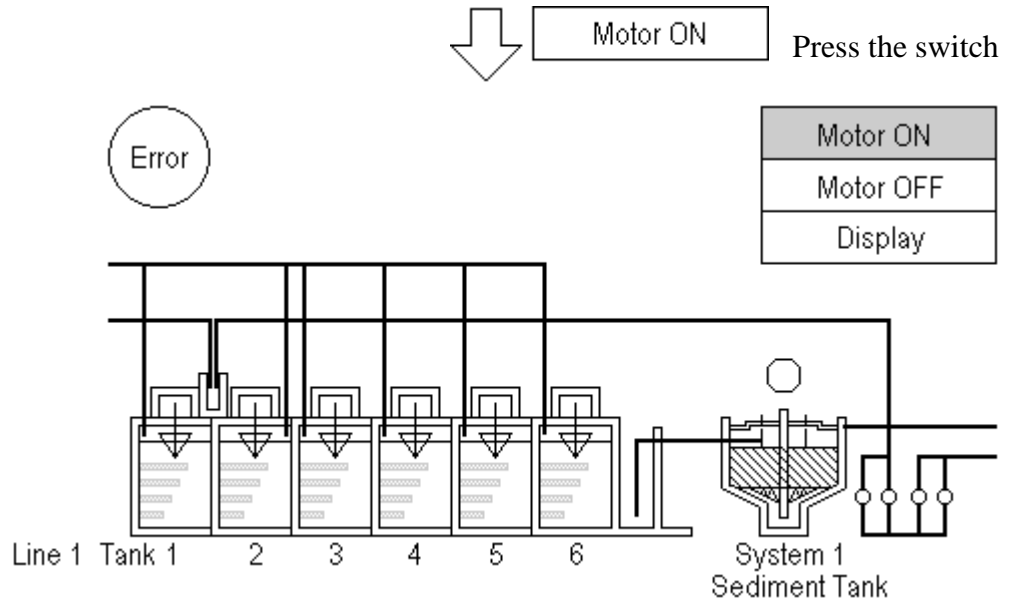

ASCII Code "31" = Data "1" is output to the Host, causing the screen to change.

4 n:1 (Multi-link)

This chapter describes the overview of n:1 (multi-link) communications and the necessary steps for preparing multi-link communications.

4.1 n:1 About Multi-link

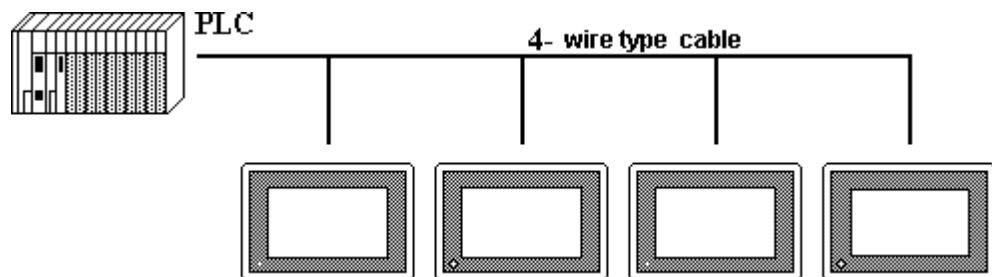

The communication software supports Programless **n:1** (multi-link) connections, whereby multiple GPs are connected to a single PLC.

In **n:1** (multi-link) communication, a token, which authorizes PLC communication, is passed successively among the GPs so that communication with the PLC occurs in an orderly fashion.

The maximum total length of the cables is 600m. However, when the maximum extended length for the PLC is less than this, model the setup after the PLC value.

- **Connection multiple GP units to one PLC**

Multiple GPs can be connected to each PLC computer (top unit) Link I/F. Maximum 16 connections are possible; for most practical purposes, use up to 4 connections.

- **Programless Communication**

A particular program for **n:1** (multi-link) is not necessary, as the selected Programless protocol can also be used in the multi-link format.

- **Multi-link connections possible without exclusive hardware**

- **from Large to Medium sized GP units**

Large and Medium sized GP-*70, GP-77R and GP2000 Series displays can be connected in a *random* order in **n:1** (multi-link) communication.

- **GP screen data designed for 1:1 connection**

The multi-link connection can even use GP screen data designed for a **1:1** connection.

•Maintenance possible on connected GP

In the middle of RUN mode for a **n:1** (multi-link) connection, the communication of a *free* GP can be stopped. This function is available so that adding or editing screen data, turning the GP power On/Off, debugging, maintenance, and so on, can be performed without disrupting the system.



- In GP's INITIALIZE/PLC SETUP/STATION SETUP screen, enter the same NETWORK INFORMATION ADDRESS for all connected GP's.
- Because increasing the number of GP connections slows the GP display and operation speed, consider it carefully at the end of your system calculations.
- To utilize display efficiency, set up the tag addresses consecutively; when tag addresses are *not* consecutive, the processing speed decreases.
- The PLC Scan Time (cycle time) affects the base system's response time.
- When the PLC power is turned off during communication, a communication error may appear on the GP.
- When a connector hood is used to ground the FG line at the end of the GP—PLC connection, use an electric conductor.



Entering touch input on multiple GPs at the same time may increase the time it takes for the PLC to respond. This occurs because the first screen must refresh its display before the second display can receive its reply. As a result, do not use both GP units at the same time.



When GP-*30 series and GP-*70 series systems are combined and n:1 (multi-link) connections are used, note that the GP-*30 systems cannot use the following functions.

- **PLC exclusive usage that uses the system data area's LS14.**
- **Function for informing other GPs when a single GP has exclusive use of the PLC.**
- **Time for release of exclusive use.**

<Matrix showing GP recognition of PLC Monopoly>

GP-*30 series	GP-*50 series	GP-*70/GP2000 series
Touch Panel Monopoly	Not recognized	Not recognized
Not recognized	Exclusive use of either touch panel or LS14	Recognized
Not recognized	Recognized	Exclusive use of the touch panel or of the LS14



For GPs that do not recognize PLC monopoly, their display is not refreshed until monopoly is released, and errors are not displayed.

Reference For information about GP-*30 series panels' exclusive use of PLCs, refer to GP series PLC connection manual, multi-link protocol

Reference For information about GP-*70 series panels' exclusive use of PLCs, refer to **Chapter 4.5, About PLC monopoly**

Also, with the GP70 series, PLCs connectability may vary depending on the models involved.

■ Option Parts

Digital's *Multi-link* type cable or RS-422 connector terminal adapter is recommended for **n:1** (multi-link) connections.

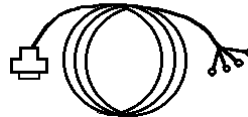

**Mitsubishi type Cable
(GP230-IS12-0)**

I/F cable (5m) to run communication between various PLCs and GP.

Can use as a secondary cable from the Relay terminal.

**RS-422 Connector Terminal
Adapter (GP070-CN10-0)**

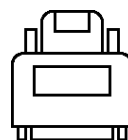

This adapter exchanges the RS-422 terminal output from the GP Series' SIO connector.

Connect with the recommended cable by the corresponding PLC maker.



4.2 Connectable PLCs

The following is a list of the PLCs which support GP multi-link connections.

Co.	Series Name	CPU	Link I/F	Comments	Screen Editor PLC setup	GP Series GLC2400 Series	GLC100 Series GLC300 Series	
M I T S U B I S H I E L E C T R I C	MELSEC-A	A2A	AJ71C24-S6		Mitsubishi's MELSEC-AnA (LINK)	○	○	
		A3A	AJ71C24-S8					
		A4U	AJ71UC24					
		A2U	AJ71UC24					
		A2US	A1SJ71C24-R4					
	A2USH-S1	A1SJ71UC24-R4						
	MELSEC-A	A1N	AJ71C24		Mitsubishi's MELSEC-AnN (LINK)	○	○	
		A2N	AJ71C24-S3					
		A3N	AJ71C24-S6 AJ71C24-S8 AJ71UC24					
		AOJ2	AOJ2-C214-S1					
		AOJ2H						
	A1SJ	A1SJ71UC24-R4						
	A1S,A1SH							
	A2SH	A1SJ71C24-R4						
	MELSEC-A2C	A2CCPUC24	Link I/F on CPU Link		Mitsubishi's MELSEC-AnN (LINK)	○	○	
	MELSEC-FX	FX _{2N}	FX2N-485-BD		Mitsubishi's MELSEC-FX (LINK)	○	○	
	MELSEC-QnA	Q2A	Q2A-S1	AJ71QC24		Mitsubishi's MELSEC-QnA (LINK)	○	X
			Q4A	AJ71QC24N-R4		Mitsubishi's MELSEC-QnA (LINK)		
		Q2AS	AJ71UC24	Usable device type limited	Mitsubishi's MELSEC-AnA (LINK)			
			A1JS71QC24		Mitsubishi's MELSEC-QnA (LINK)			
Q2AS-S1		A1JS71UC24	Usable device type limited	Mitsubishi's MELSEC-AnA (LINK)				
		A1SJ71QC24N		Mitsubishi's MELSEC-QnA (LINK)				
A1SJ71UC24-R4		Usable device type limited	Mitsubishi's MELSEC-AnA (LINK)					
Q4AR	AJ71QC24N		Mitsubishi's MELSEC-QnA (LINK)					
MELSEC-Q	Q02CPU-A	A1SJ71UC24-R4		Mitsubishi's MELSEC-AnA (LINK)	○	○		
	Q02HCPU-A			Mitsubishi's MELSEC-AnA (LINK)				
	Q06HCPU-A			Mitsubishi's MELSEC-QnA (LINK)				
	Q02CPU	QJ71C24		Mitsubishi's MELSEC-QnA (LINK)				
	Q02HCPU			Mitsubishi's MELSEC-QnA (LINK)				
	Q06HCPU			Mitsubishi's MELSEC-QnA (LINK)				
	Q12HCPU			Mitsubishi's MELSEC-QnA (LINK)				
	Q25HCPU			Mitsubishi's MELSEC-QnA (LINK)				

Co.	Series Name	CPU	Link I/F	Comments	Screen Editor PLC setup	GP Series GLC2400 Series	GLC100 Series GLC300 Series	
O M R O N	SYSMAC C	C500 C500F C1000H C1000HF C2000 C2000H	C500-LK201-V1 C500-LK203	C1000HF can only use C500-LK203 link unit.	OMRON SYSMAC-C series			
		C200H C200HS	C200H-LK202					
		C120 C120F C200H C500 C500F C1000H C2000 C2000H	C120-LK202-V1					
		SRM1-CO2 CPM1-20CDR-A CPM2A	CPM1-CIF11					
	SYSMAC-α	C200HX-CPU64 C200HG-CPU43 C200HE-CPU42	C200HW-COM06	CPU64 checks the connection. Only the 4- wire type can be used.				
		C200HX-CPU64-Z	C200H-LK202-V1					
	SYSMAC CV	CV500 CV1000 CVM1	Link I/F on CPU unit		OMRON SYSMAC-CV			
			CV500-LK201					
	SYSMAC CS1	CS1H-CPU67 CS1H-CPU66 CS1H-CPU65 CS1H-CPU64 CS1H-CPU63 CS1G-CPU45 CS1G-CPU44 CS1G-CPU43 CS1G-CPU42	CSW-SCB41	RS-422 (Port 2)	OMRON SYSMAC-CS1 series		○	X
	H I T A C H I	HIDIC H	H-2000 H-2002	COMM-H COMM-2H	Standard HIZAC H series. Transmission control procedure 1	HITACHI HIZAC-H series		
H-302 H-702 H-4010			COMM-2H					
EH-150 (EH-CPU448)		Serial Port1 on CPU unit				○	X	
		H-302 H-702 H-2002 H-4010	COMM-2H	Transmission control procedure 2	HITACHI HIDIC-H2 series			

* 1 Use Version 1.8 or higher.

Co.	Series Name	CPU	Link I/F	Comments	Screen Editor PLC setup	GP Series GLC2400 Series	GLC100 Series GLC300 Series
S M H A I T S A U	MEWNET	FP10S *1 FP10SH	Link I/F on CPU unit		MATSUSHITA MEWNET-FP series	○	X
Y O K O G A W A	FACTORY ACE	FA-M3	F3LC11-2N	CPU uses F3SP20-ON and F3SP35-5N to check connection.	YOKOGAWA *1 FACTORY ACE 1:1 Comm.	○	X
		FA-M3 (n:m Connection)	F3LC11-2N	In addition to the FA-M3, multi-link connections using a digital Indicating Controller (UT37/38/2000) and recorder (mR series) can be made without programming. The CPU uses F3SP20-N and F3SP35-5 to check the	YOKOGAWA *2 FACTORY ACE 1:n Comm.		
T O S H I B A	PROSEC T	T3	Link I/F on CPU unit		TOSHIBA PROSEC-T Series	○	X
R B A O R L C A L K D E W L N E E L Y L	SLC500	SLC-5/03 SLC-5/04	Link I/F on CPU unit		Allen Bradley SLC500 Series	○	X
K E Y E N C E	KZ-300	KZ-300	KZ-L2		KEYENCE KZ-300 Series	○	X
	KZ-350	KZ-350					

*1 "FA-500" in earlier version (GP-PROII, GP-PROIII)

*2 "FA-500M" in earlier version (GP-PROII, GP-PROIII)

Co.	Series Name	CPU	Link I/F	Comments	Screen Editor PLC setup	GP Series GLC2400 Series	GLC100 Series GLC300 Series
Y A S U K A W A	MEMOCON- SC	GL120 GL130	JAMSC- 120NOM27100		YSUKAWA Memocon-sc Series	○	X
S H A R P	New Satellite JW	JW-33CUH3	Link I/F on CPU unit JW-21CM *1		Sharp New Satellite JW Series	○	X

**1 Be sure to use a ROM version that is 30Hn or higher when you use JW-21CM. If the ROM version is 30H, some file registers will not be available. The JW30H cannot be used, because it does not have a ROM version mark.*



If a PLC maker changes their PLC specifications, or upgrades the PLC version, there is a possibility that communication with the GP may not operate normally.



Depending on the CPU or Link I/F being used, communication speed vary. Also, when multilink connections (n:1) are used, speed may be slower. Thus, when designing your system, please check that the communication speeds meet your requirements.

4.3 Prior to RUN mode

This section outlines the steps for **n:1** (multi-link) communication. Particularly important steps have a rectangular frame.

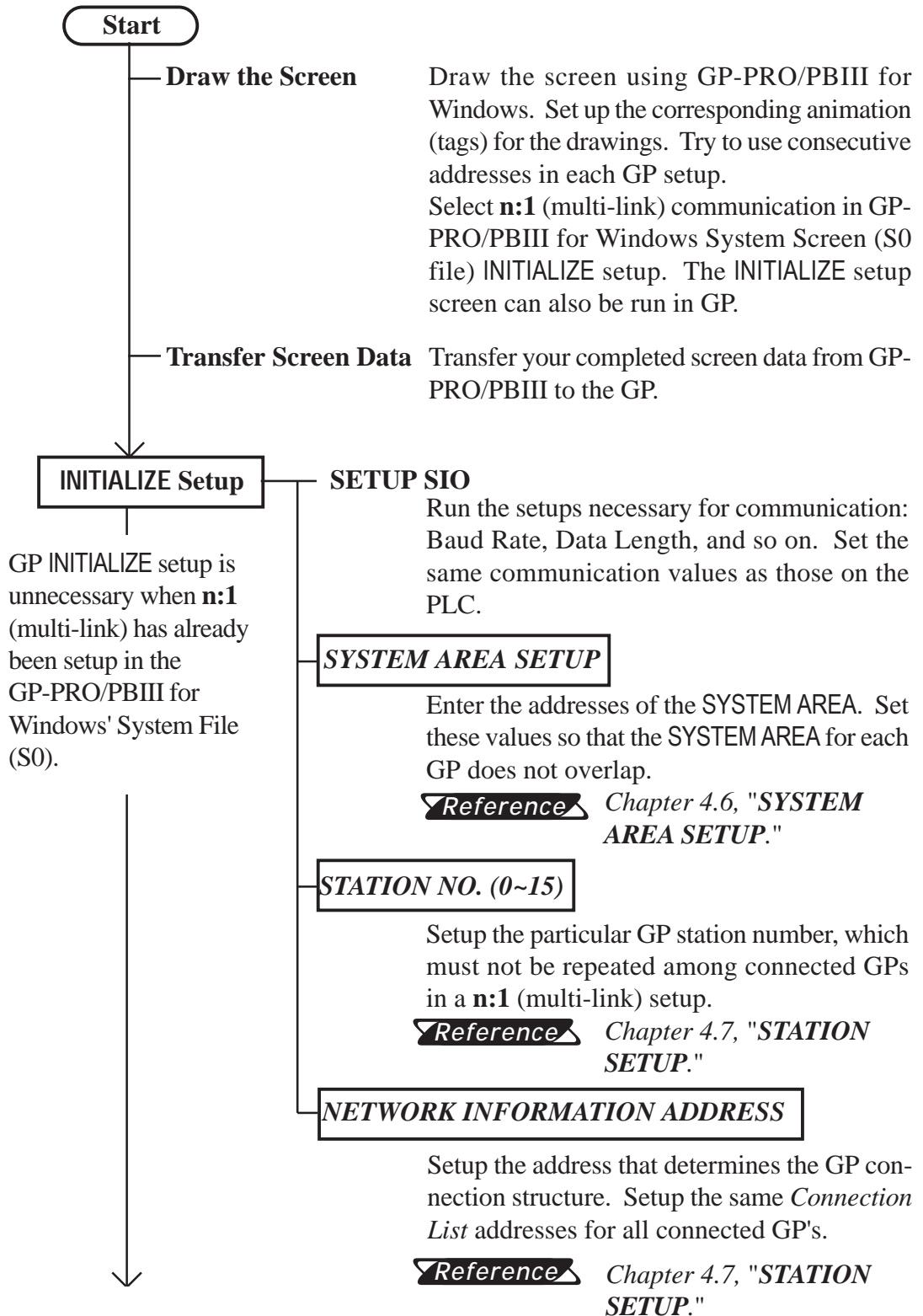

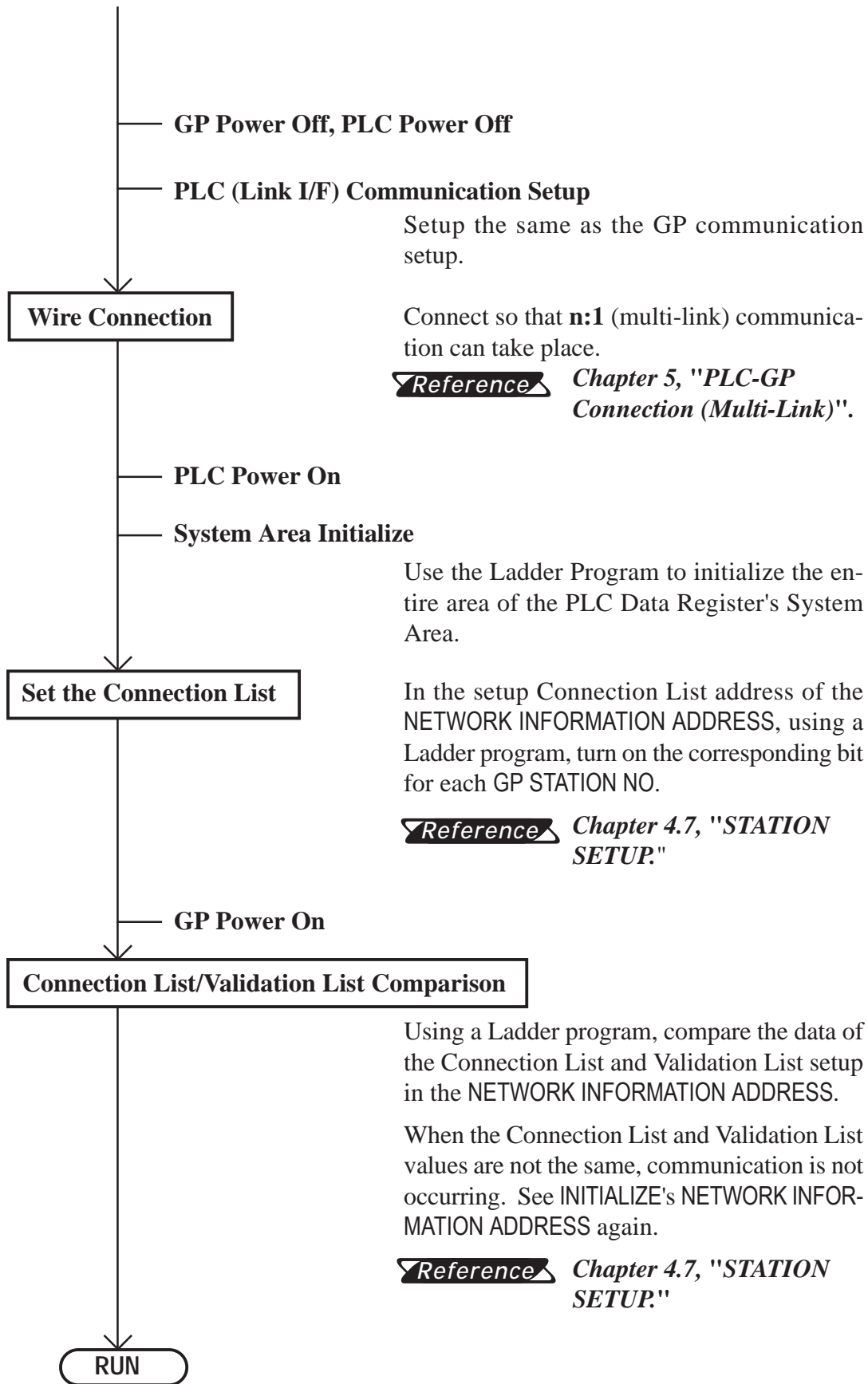

4.4 PLC Scan Time

When using the GP in **n:1** (multi-link), the PLC scan time greatly influences the GP Display/Operation speed. The time it takes to run a process series, common to PLCs, and repeated as shown in the diagram below, is known as the *scan time*. If the scan time gets longer, the Display/Operation speed, because it remains in proportion, slows down.

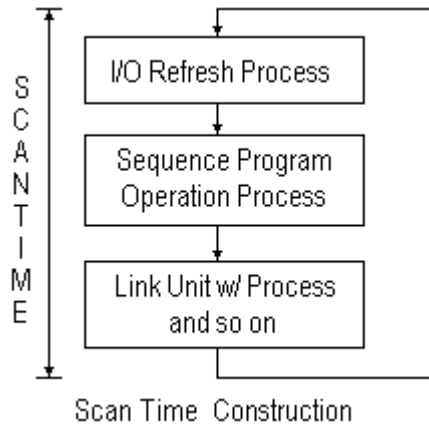

In the step *Link I/F w/ Process and so on* in the above diagram, the PLC runs the process linked to the command *from* the GP.

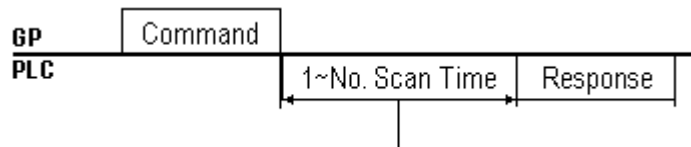

After sending a command, the time it takes for a response varies among PLC's.

Wait Time Reference Example

- MELSEC A Series
 - Read 1 Scan time
 - Write 2 Scan time



For details, refer to the corresponding PLC manual.

To raise (speed up) the response time, wherever possible, create a system with short scan times. (For example, for sequence program allocation and so on.)



4.5 About PLC Monopolize

A PLC monopoly occurs when one of many GPs uses the PLC exclusively. For example, use PLC monopolize when you wish to setup data using the keyboard on the GP screen, or when displaying data Input/Output on a single GP.

■ PLC Monopoly

There are two ways of monopolizing the PLC:

1. Turn bit 7 of System Area address LS14 ON,
2. Set the GP TOUCH MONOPOLIZE option ON in GP's INITIALIZE off-line menu.

Reference Chapter 4.8, "CUSTOMIZE SETUP."

■ PLC Monopoly Release

Turn OFF the #7 bit of the GP System Area's LS14.

When the PLC is used exclusively using the method stated above in (1), the time period of exclusive use can be set. After that period is over, exclusive use is automatically released.

Reference Chapter 4.8, "CUSTOMIZE SETUP."

When a GP is monopolizing the PLC, bit 7 of System Area address LS6 (Status) turns ON for the other GPs. These GPs are in a *wait* state.

Operations run in GPs in a wait state are carried out only after communication is resumed. For this reason, there is the possibility errors will occur in accumulated operations. Plus, the PLC cannot check the System Area bit of Wait and See GPs.

We recommend using L-tag and W-tag, U-tag, and so on, to display whether a GP is in Monopoly or Wait and See mode.

E.g. Make the 7th bit of System Area's LS6 (Status) the trigger bit which displays the L-tag message "Waiting".

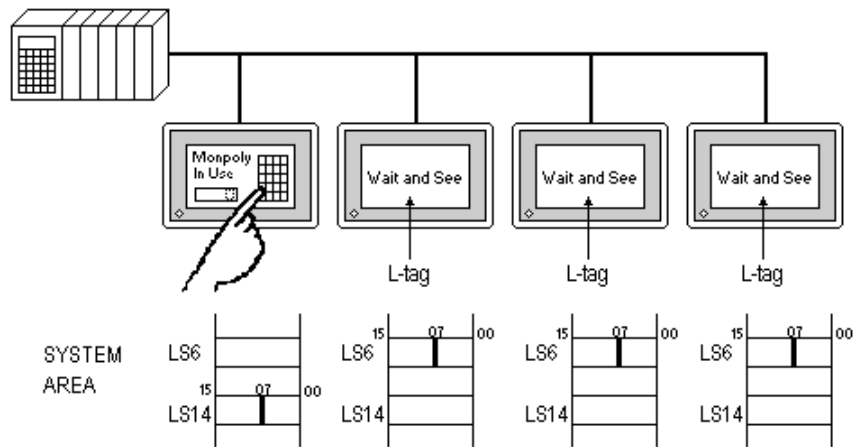

- When LS14's (Control) bit is turned ON in multiple GPs, the PLC Monopolize function is carried out on the GP whose bit turned ON first.
- While one of the GPs monopolizes the PLC, the other GP displays remain static.

4.6

SYSTEM AREA SETUP

This section's data will help you to set up the System Area*¹.

In n:1 (multi-link) communication, to layout the System Area for the number of connected GPs, data of the entire system will increase. For this reason, the processing speed of each GP may slow down.

Selecting only necessary items for the System Area is recommended.

When setting the system data area while in the GP's off-line mode, be sure to use the [2 SYSTEM AREA SETUP], located inside the [1 INITIALIZE] menus's [2 SETUP OPERATION SURROUNDINGS] selection screen.

SYSTEM AREA SETUP		CONFIRM	CANCEL
1	CURRENT SCREEN NO. (1 WORD)	8	CLOCK DATA (SET) (4 WORDS)
2	ERROR STATUS (1 WORD)	9	CONTROL (1 WORD)
3	CLOCK DATA (CURRENT) (4 WORDS)	A	RESERVED (1 WORD)
4	STATUS (1 WORD)	B	WINDOW CONTROL (1 WORD)
5	RESERVED (1 WORD)	C	WINDOW REG. NO. (1 WORD)
6	CHANGE SCREEN NO. (1 WORD)	D	WINDOW LOCATION (2 WORDS)
7	DISPLAY ON/OFF (1 WORD)		SYSTEM AREA SIZE: WORD(S)

(Item numbers displayed in reverse mode are selected.)

(GP-470 Screen)



- Setup the System Area for all the connected GP's. Do not overlap any of the allotted PLC Data Register (D) or Data Memory (DM) addresses.
- When System Area items are not selected, the Reading Area start address becomes the System Area start address.
- There is a process where not selecting the System Area items increases the GP management speed; however, operations where the PLC controls the GP, such as a Screen Change command sent from the PLC or PLC monopolize, cannot be run.
- When you wish to change the screen despite System Area items not being selected, indirectly use W-tag's ADD mode, and write the PLC Data Register contents into GP's internal LS8.

*1 The System Area is the area necessary for the PLC to control the GP. The items selected here are allotted to the PLC's internal memory.

Reference For details about the System Area, refer to **Chapter 1.1, Direct Access Communication**.



4.7 STATION SETUP

The STATION SETUP, necessary for the **n:1** (multi-link) setup, checks whether correct communications run with the connected GP System configuration.

When setting the system data area while in the GP's OFFLINE mode, be sure to use the [2 STATION SETUP], located inside the [1 INITIALIZE] menu's [2 SET UP OPERATION SURROUNDINGS] selection screen.

STATION SETUP		SET	CANCEL
NETWORK INFORMATION ADDRESS	[0]		
STATION NO.	[0]		

(GP-470 Screen)

- **NETWORK INFORMATION ADDRESS**

In the **n:1** (multi-link) connection, the Network Information uses 2 words in its correspondences. These 2 words are made up of the Connection List and the Validation List (described later in this section). Allocate these respective areas into the PLC's Data Register (D) or Data Memory (DM).

PLC Data Register

+ 0	CONNECTION LIST	PLC-->GP
+ 1	VALIDATION LIST	GP-->PLC



Important

In the NETWORK INFORMATION ADDRESS, set up the same address to all the GPs connected to the same Link I/F. Furthermore, when there are 2 ports in the connected Link I/F, do not make them the same address.

- **Connection List**

The word address for the Connection List sets up the number of GPs connected to the PLC, registered beforehand on the PLC side. When these GPs are connected to the PLC, the corresponding PLC bit numbers for the particular GP Stations (see bottom) turn on.

- **When the GP is connected to the PLC, and the option of GP only correspondence ends and OFFLINE mode is entered, the GP Station Number turns the**



Note: corresponding PLC bit off.

Bit 15 Bit 0

15	14	13	12	11	10	9	8	7	6	5	4	3	2	1	0
unit	unit	unit	unit	unit	unit	unit	unit	unit	unit	unit	unit	unit	unit	unit	unit

For example, when these 4 GP units—bit 0, bit 2, bit 3, bit 5—are connected, 002D (h) is written here.

Connection List

0	0	0	0	0	0	0	0	0	0	0	0	1	0	1	1	0	1
---	---	---	---	---	---	---	---	---	---	---	---	---	---	---	---	---	---

 002D (h)



- Be certain to set up the GP before running the program.
- Turn bits not connected to the GP off.



Avoid keeping the bits in the list of connected stations OFF for long periods of time even though the GP is connected.

• **Verification List**

This area responds to the correspondence from each connected GP. In the Verification List, when the same bit numbers as the Connection List turn On, the correspondence is accepted. The Station Numbers of the communicating GPs turn their corresponding PLC bit number on.

Bit 15

Bit 0

15	14	13	12	11	10	9	8	7	6	5	4	3	2	1	0
unit	unit	unit	unit	unit	unit	unit	unit	unit	unit	unit	unit	unit	unit	unit	unit

If the correspondence between the GP and PLC is correct, the same value as in the Connection List is written to the Verification List.

For example, the value 002D (h) in the Connection List, set up as the 0 bit, 2 bit, 3 bit, and 5 bit, writes to the Verification List.

Connection List

0	0	0	0	0	0	0	0	0	0	0	0	1	0	1	1	0	1
---	---	---	---	---	---	---	---	---	---	---	---	---	---	---	---	---	---

 002D (h)

Verification List

0	0	0	0	0	0	0	0	0	0	0	0	1	0	1	1	0	1
---	---	---	---	---	---	---	---	---	---	---	---	---	---	---	---	---	---

 002D (h)



Note: When the Connection List and Verification List do not match, a COMMUNICATION ERROR occurs. Check the setup again.



Careful! When changing the type of connection, first turn all the List bits Off.

- **STATION NO.**

This is the setup for the GP Station Number mentioned in the above section. The setup range is from 0 to 15, and the only other restriction is the GP STATION NO. must be unique in the system. If STATION NO.'s are repeated, a COMMUNICATION ERROR occurs.



The STATION NO. is the number allocated to the particular GP unit. This number is not related to the Link I/F Machine number.

< Station Setting Data Example >

The following shows the example of station settings used to connect two (2) GPs by n:1(multi-link) connection.

	GP1	GP2
Station No. ^{*1}	1	1
GP Station No. ^{*2}	0	1
Storage Address ^{*3}	D100	D100

**1 Enter the station numbers of the link unit being connected.*

**2 Be sure that you do not create any duplicate GP station numbers (from 0 to 15).*

**3 All GPs must be set so as to use the same storage address to avoid overlapping System Data Area's settings.*

Writing [3] in [D100] enables the system to start communication after you finished all settings shown above.



4.8 CUSTOMIZE SETUP

The Customize function alters the **n:1** (multi-link) connection's communication to make it more effective. To run communication efficiently, determine whether to use Operation or Display priority with your GP. As a result, the communication response speed can be upgraded. (However, this changes with the screen information.)

When setting the system data area while in the GP's OFFLINE mode, be sure to use the [CUSTOMIZE SETUP], located inside the [INITIALIZE] menu's [SET UP OPERATION SURROUNDINGS] selection screen.

CUSTOMIZE SETUP			SET	CANCEL
PLC PRIORITY	DISPLAY	OPE.		
GP TOUCH MONOPOLIZE	ON	OFF		
MONOPOLIZE TIME	()	* 10 seconds		

(GP-470 Screen)

- **PLC PRIORITY**

According to how the GP is used, select either Operation priority (OPE.) or Display priority.

- **Display**

Set up the GP to this option when using the GP mainly as a monitor screen. The GP will command a higher display speed as a result; however, the response time for the touch panel's operations will slow.

- **Operation**

Set up the GP to this option when using the GP mainly as an operation panel. As a result, the GP will command better touch panel numeric input and switch response times.

Leaving the GP in this mode does not influence the touch panel operation response time of the rest of the GPs very much; however, the screen display renewal cycle will slow down.



- **In a basic setup, run the same setup for all connected GPs.**
- **To increase the display speed, restrict the address setup to consecutive addresses wherever possible. And make bit addresses consecutive to the word unit.**

- **Speed Difference between Display Priority and Operation Priority**

When using the Mitsubishi Electric Corp. A3A PLC, with a scan time of 20ms with consecutive addresses (80 words not included in the System Area), the difference in reading speed is as shown in the following graphs.

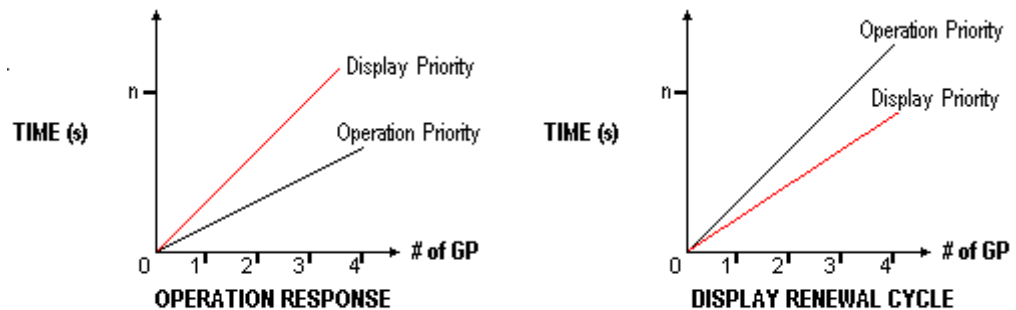

- **GP TOUCH MONOPOLIZE**

The monopolizing of touch panel use can be set ON or OFF. When you want to use the PLC exclusively (**Reference** Chapter 4.5, About PLC *Monopolize*.) with a Momentary operation setup on the touch panel, turn GP TOUCH MONOPOLIZE on.

When this setup is on, the touch panel uses the PLC exclusively whenever the momentary operation setup on the panel is pressed. In this way, you can perform inching operation via a momentary switch. When you stop pressing the panel, exclusive use ends.

- **MONOPOLIZE TIME (0~2550s)**

This field controls the length of time for the monopolize process when no other touch panel operations are performed. The Monopolize process begins when the System Data Area's 7th bit of word address LS14 turns on, and ends either when the bit turns off, or when the time set here passes.



- Pressing the touch panel in the middle of the monopolize process interrupts the MONOPOLIZE TIME function, ending exclusive use.
- When MONOPOLIZE TIME is set to 0, the monopolize function does not end automatically.

Reference For more about the contents of System Data Area LS6 (status) and LS14 (control), refer to Chapter 1.1.4, "Contents and Range of System Area."

5 PLC-GP Connection (Multi-link)

This chapter describes the system configuration of PLC made by various manufacturers and the GP, and shows connection diagrams, supported devices, and examples of setting up the operating environment.



5.1 Mitsubishi Electric

5.1.1 System Structure

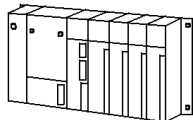

The following describes the system structure for connecting the GP to Mitsubishi Electric PLCs.

Reference The Cable Diagrams mentioned in the following tables are listed in the section titled "5.1.2 Cable Diagrams".

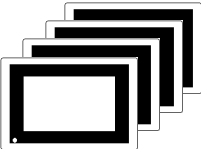

■ MELSEC-A Series (using Link I/F)

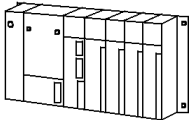
CPU	Link I/F	Cable Diagram	GP
	Computer Link Unit 		
A2A A3A A4U	AJ71C24-S6 AJ71C24-S8 AJ71UC24	(Cable Diagram 1)	GP series
A2US	A1SJ71C24-R4		
A2USH-S1	A1SJ71UC24-R4		

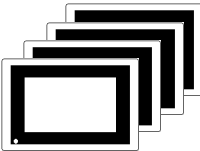
■ MELSEC-N Series (Link I/F)

CPU	Link I/F	Cable Diagram	GP
	Computer Link Unit 		
A1N A2N A3N	AJ71C24 AJ71C24-S3 AJ71C24-S6 AJ71C24-S8 AJ71UC24	(Cable Diagram 1)	GP series
A0J2,A0J2H	A0J2-C214-S1		
A1S	A1SJ71C24-R4		
A1SJ,A2SH,A1SH	A1SJ71UC24-R4		

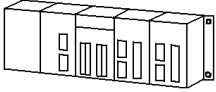
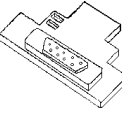

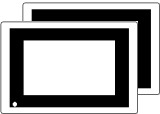
■ MELSEC-FX Series (Expansion Board with Link I/F protocol) *1

CPU	Adapter	Cable Diagram	GP
	 Expansion board		
FX2N *2	FX2N-485-BD	RS-422 (Cable Diagram 2)	GP series

*1 Choose Mitsubishi's MELSEC-FX2(Link) as the GP-PRO/PBIII project file's PLC type.

*2 The PLC's system version should be at least 1.06 or later. Check the PLC's version by reading out the data from the register (D8001). For detailed information refer to the Mitsubishi's FX 2N Series Micro Sequencer manuals.

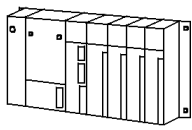

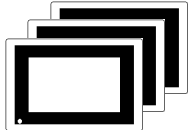
■ MELSEC-QnA Series (using Link I/F)

CPU	Link I/F	Cable Diagram	GP
	Serial Communication Unit / Computer Link Unit 		
Q2A, Q2A-S1, Q4A	AJ71QC24 (serial communication unit) *1 AJ71UC24 (computer link unit) AJ71QC24N-R4	RS-422 (Cable Diagram 1) RS-422 (Cable Diagram 2) for CN-1	GP series
Q2AS	A1SJ71QC24N (serial communication unit) *2 A1SJ71UC24 (computer link unit)	RS-422 (Cable Diagram 1)	
Q2AS-S1	A1SJ71QC24N A1SJ71UC24-R4	RS-422 (Cable Diagram 1)	
Q4AR	AJ71QC24N	RS-422 (Cable Diagram 1)	

*1 ROM : must be higher than 7179B.

*2 ROM : must be higher than 7179M.

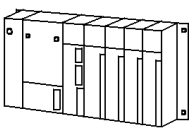
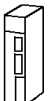
■ MELSEC-Q Series

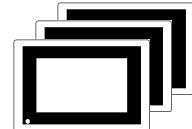
CPU	Link I/F	Cable Diagram	GP
	Serial Communication Unit / Computer Link Unit 		
Q02CPU-A Q02HCPU-A Q06HCPU-A	A1SJ71UC24-R4	RS-422 (Cable Diagram 1)	GP series
Q02CPU Q02HCPU Q06HCPU Q12HCPU Q25HCPU	QJ71C24	RS-422 (Cable Diagram 1)	

5.1.2 Cable Diagrams

The cable diagrams illustrated below and the cable diagrams recommended by Mitsubishi Electric Corp. may differ, however, using these cables for your PLC operations will not cause any problems.

Cable Diagram 1

- When using Digital's RS-422 connector terminal adapter GP070-CN10-O

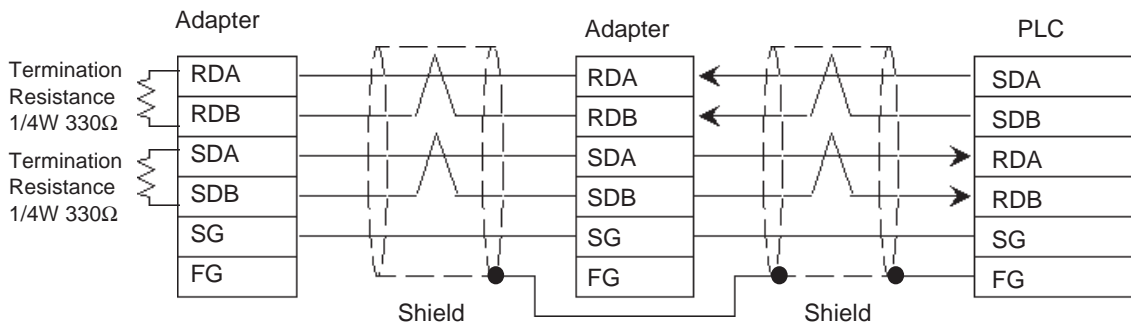

- When using Digital's Multi-link Cable, GP230-IS12-O

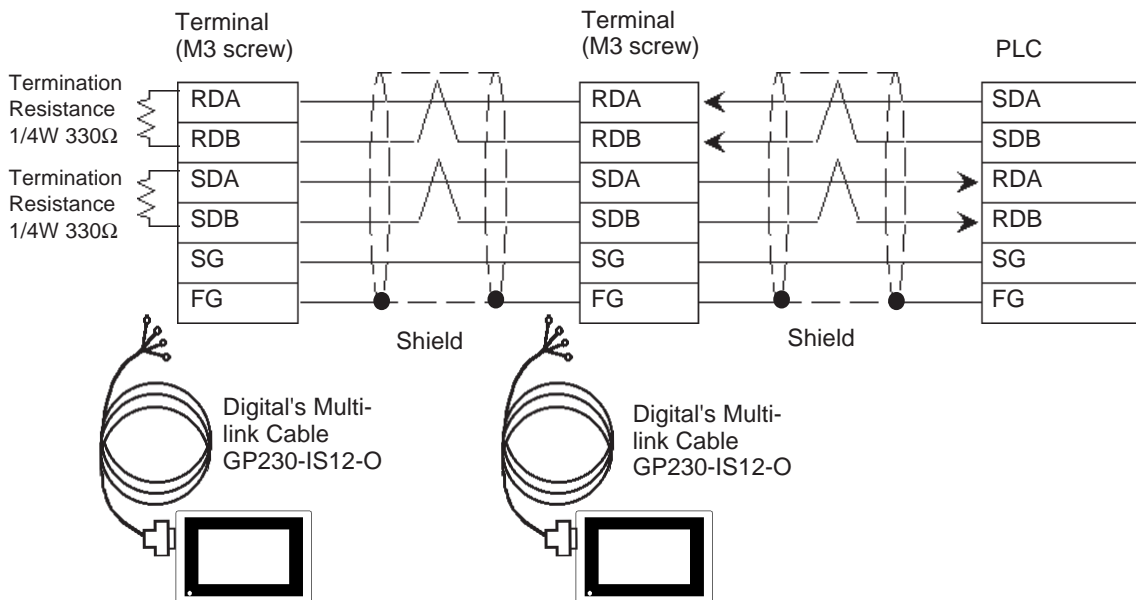



Ground your PLC's FG terminal according to your country's applicable standard. For details, refer to the corresponding PLC manual.



- Pull out the Transfer Cable Shield cover and shape it into a wire and connect it to the PLC's FG terminal.
- GP230-IS12-O Cable FG terminal is not connected to GP's FG.
- Place a Termination Resistor at both ends of the cable. The Termination Resistor is automatically setup when the PLC's Termination Resistor switch is turned ON.
- For the RS-422 connection, use a cable length less than 500m.
- As a general rule, connect the PLC at either end of the circuit, not in the middle.

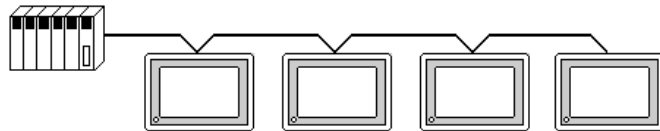

When making your own cable, Mitsubishi's SPEV (SB)-MPC-0.2*3P cable is recommended as the connection cable.

The cable connection lines are as illustrated below and should be less than 10m.

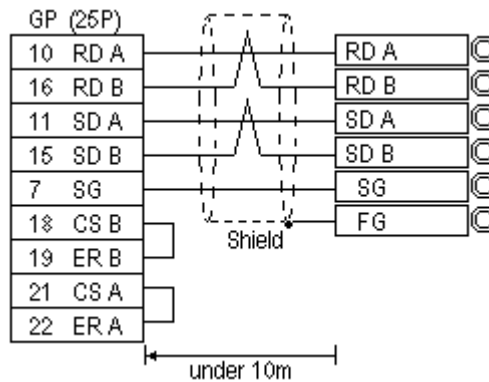

Cable Diagram 2

- When using Digital's RS-422 connector terminal adapter GP070-CN10-O

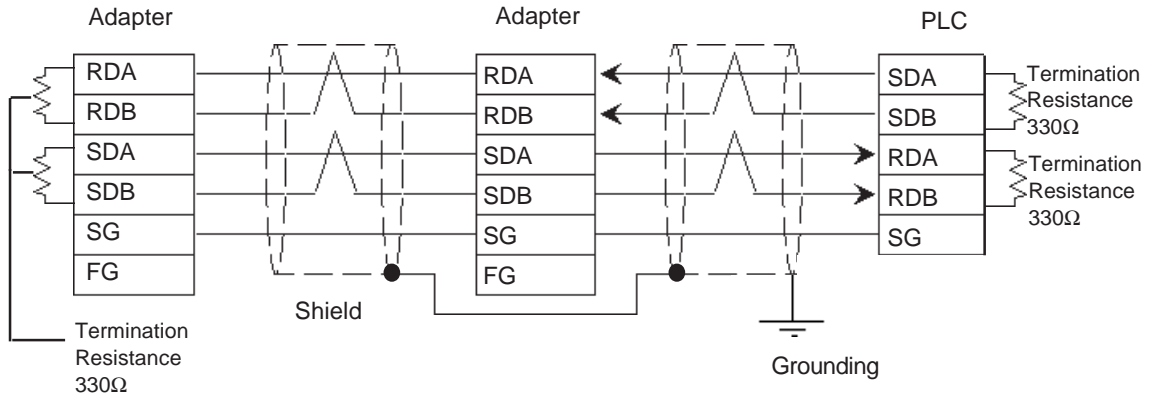

- When using Digital's GP230-IS12-0 (Multi Link Cable)

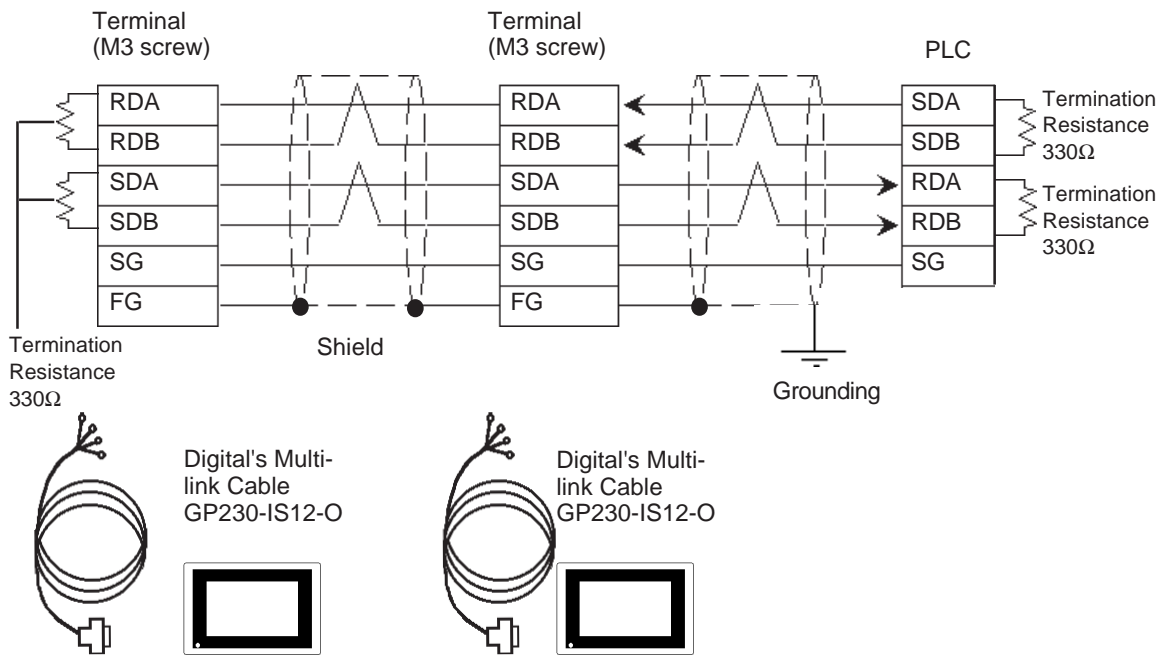

Ground your PLC's FG terminal according to your country's applicable standard. For details refer to your PLC's manual.



- Pull out a small amount of the Transfer Cable's shield, make a wire out of it and connect it to the PLC's FG terminal.
- The GP230-IS12-0 cable's FG terminal is not connected to the GP's FG line.
- Connect a terminating resistor to both ends of the cable.
- When using FX2N-485-BD, the cable must not be longer than 50m.
- As a general rule, connect the PLC at the end of the circuit's wiring (see below).



- When making your own cable, the Mitsubishi SPEV (SB)-0.2-2P is recommended.
- The cable connection lines are as shown below. The cables used between the GP and the terminals should be less than 10meters long.

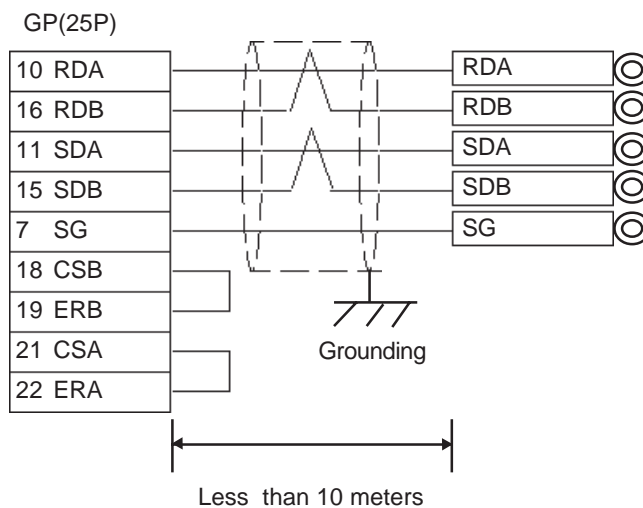

5.1.3 Supported Devices

The following describes the range of devices supported by the GP.

■ **MELSEC-A Series (AnA/ AnU/ A2US/ A2USH-S1)**

 Setup System Area or Communication Information's Storing Address here.









Device	Bit Address	Word Address	Particulars
Input Relay	X0000 ~ X1FFF	X0000 ~ X1FF0	xxx0
Output Relay	Y0000 ~ Y1FFF	Y0000 ~ Y1FF0	xxx0
Internal Relay	M0000 ~ M8191	M0000 ~ M8176	6
Latch Relay	L0000 ~ L8191	L0000 ~ L8176	6
Special Relay	M9000 ~ M9255	M9000 ~ M9240	6
Annunciator	F0000 ~ F2047	F0000 ~ F2032	6
Link Relay	B0000 ~ B1FFF	---	
Timer (contact)	TS0000 ~ TS2047	---	
Timer (coil)	TC0000 ~ TC2047	---	
Counter (contact)	CS0000 ~ CS1023	---	
Counter (coil)	CC0000 ~ CC1023	---	
Timer (current value)	---	TN0000 ~ TN2047	
Counter (current value)	---	CN0000 ~ CN1023	
Data Register	---	D0000 ~ D8191	Bit 5
Special Register	---	D9000 ~ D9255	Bit 5
Link Register	---	W0000 ~ W1FFF	Bit F
File Register	---	R0000 ~ R8191	Bit 5 *1

L/H

* 1 When using the File Register and the AnA or AnU, use the User's memory area in the memory cassettes.
 When the File Register is setup when the memory cassette is not in use, an error will develop when communicating.

■ MELSEC-N Series (AnN/ A2C/ A1S/ A1SJ/A2SH)

 Setup System Area or Communication Information's Storing Address here.

Device	Bit Address	Word Address	Particulars
Input Relay	X0000 ~ X07FF	X0000 ~ X07F0	
Output Relay	Y0000 ~ Y07FF	Y0000 ~ Y07F0	 *1
Internal Relay	M0000 ~ M2047	M0000 ~ M2032	
Latch Relay	L0000 ~ L2047	---	
Special Relay	M9000 ~ M9255	M9000 ~ M9240	 *2
Annunciator	F0000 ~ F255	F000 ~ F240	
Link Relay	B0000 ~ B03FF	---	
Timer (contact)	TS000 ~ TS255	---	
Timer (coil)	TC000 ~ TC255	---	
Counter (contact)	CS000 ~ CS255	---	
Counter (coil)	CC000 ~ CC255	---	
Timer (current value)	---	TN000 ~ TN255	
Counter (current value)	---	CN000 ~ CN255	
Data Register	---	D0000 ~ D1023	
Link Register	---	W0000 ~ W03FF	
File Register	---	R0000 ~ R8191	 *3

L/H

* 1 The Output Relays Y01F0-Y01FF (word Y01F0) are used by the PLC, and cannot be set.. (only for A2C)







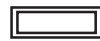

* 2 A MELSEC-AnN and AJ71C24-S3 (or AJ71C24) cannot be matched and used.

* 3 When using the File Register and the AnN, use the User's memory area in the memory cassettes.

When the File Register is setup when the memory cassette is not in use, an error will develop when communicating.

■ MELSEC-FX Series (using Expansion board with Link Protocol)

 Setup System Area or Communication Information's Storing Address here.

















Device	Bit Address	Word Address	Particulars	
Input Relay	X0000 ~ X0267	X0000 ~ X0240	 	L/H
Output Relay	Y0000 ~ Y0267	Y0000 ~ Y0240	 	
Auxiliary Relay	M0000 ~ M3071	M0000 ~ M3056		
State	S0000 ~ S0991	S0000 ~ S0976		
Special Auxiliary Relay	M8000 ~ M8255	M8000 ~ M8240	 *1	
Timer (contact)	TS000 ~ TS255	————		
Counter (contact)	CS000 ~ CS255	————		
Timer (current value)	————	TN000 ~ TN255		
Counter (current value)	————	CN000 ~ CN255	*2	
Data Register	————	D0000 ~ D7999		
Special Data Register	————	D8000 ~ D8255	 *1	

*1 The Special Relay and the Special Data Register are divided into three areas. These are the Exclusive Reading Area, the Exclusive Writing Area and the System Area. For details, refer to your PLC's manual.

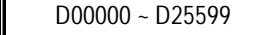
*2 Word addresses CN200 to CN255 are 32 bit counters.

■ MELSEC-QnA Series

 Setup System Area or Communication Information's Storing Address here.











Device	Bit Address	Word Address	Particulars
Input Relay	X0000 ~ X1FFF	X0000 ~ X1FF0	
Output Relay	Y0000 ~ Y1FFF	Y0000 ~ Y1FF0	
Internal Relay	M00000 ~ M32767	M00000 ~ M32752	
Special Relay	SM0000 ~ SM2047	SM0000 ~ SM2032	
Latch Relay	L00000 ~ L32767	L00000 ~ L32752	
Annunciator	F00000 ~ F32767	F00000 ~ F32752	
Edge Relay	V00000 ~ V32767	V00000 ~ V32752	
Step Relay	S0000 ~ S8191	S0000 ~ S8176	
Link Relay	B0000 ~ B7FFF	B0000 ~ B7FF0	
Special Relay	SB000 ~ SB7FF	SB000 ~ SB7F0	
Timer (contact)	TS00000 ~ TS22527	-----	
Timer (coil)	TC00000 ~ TC22527	-----	
Aggregation Timer (contact)	SS00000 ~ SS22527	-----	
Aggregation Timer (coil)	SC00000 ~ SC22527	-----	
Counter (contact)	CS00000 ~ CS22527	-----	
Counter (coil)	CC00000 ~ CC22527	-----	
Timer (current value)	-----	TN00000 ~ TN22527	
Aggregation Timer (current value)	-----	SN00000 ~ SN22527	
Counter (current value)	-----	CN00000 ~ CN22527	
Data Register	-----		
Special Register	-----	SD0000 ~ SD2047	
Link Register	-----	W0000 ~ W63FF	
Special Link Register	-----	SW000 ~ SW7FF	
File Register (normal)	-----	R00000 ~ R32767	 *1
File Register (serial)	-----	0R0000 ~ 0R7FFF 1R0000 ~ 1R7FFF	 *1

L/H

* 1 When using the File Register, a Memory Card is necessary. Depending on the Memory Card being used, the File Register's device range differs.

■ MELSEC-Q Series (A Mode CPU)

















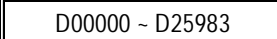

 Setup System Area or Communication Information's Storing Address here.

Device	Bit Address	Word Address	Particulars	
Input Relay	X0000 ~ X1FFF	X0000 ~ X1FF0		L/H
Output Relay	Y0000 ~ Y1FFF	Y0000 ~ Y1FF0		
Internal Relay	M0000 ~ M8191	M0000 ~ M8176		
Latch Relay	L0000 ~ L8191	L0000 ~ L8176		
Special Relay	M9000 ~ M9255	M9000 ~ M9240		
Annunciator	F0000 ~ F2047	F0000 ~ F2032		
Link Relay	B0000 ~ B1FFF	———		
Timer (Contact)	TS0000 ~ TS2047	———		
Timer (Coil)	TC0000 ~ TC2047	———		
Counter (Contact)	CS0000 ~ CS1023	———		
Counter (Coil)	CC0000 ~ CC1023	———		
Timer (Current Value)	———	TN0000 ~ TN2047		
Counter (Current Value)	———	CN0000 ~ CN1023		
Data Register	———	D0000 ~ D8191		
Special Register	———	D9000 ~ D9255		
Link Register	———	W0000 ~ W1FFF		
File Register	———	R0000 ~ R8191	 *1	

* 1 When using the File Register, a Memory Card is necessary. Depending on the Memory Card being used, the File Register's device range differs.

■ MELSEC-Q Series (Q Mode CPU)

 Setup System Area or Communication Information's Storing Address here.

Device	Bit Address	Word Address	Particulars	
Input Relay	X0000 ~ X1FFF	X0000 ~ X1FF0		L/H
Output Relay	Y0000 ~ Y1FFF	Y0000 ~ Y1FF0		
Internal Relay	M00000 ~ M32767	M00000 ~ M32752		
Special Relay	SM0000 ~ SM2047	SM0000 ~ SM2032		
Latch Relay	L00000 ~ L32767	L00000 ~ L32752		
Annunciator	F00000 ~ F32767	F00000 ~ F32752		
Edge Relay	V00000 ~ V32767	V00000 ~ V32752		
Step Relay	S0000 ~ S8191	S0000 ~ S8176		
Link Relay	B0000 ~ B7FFF	B0000 ~ B7FF0		
Special Relay	SB000 ~ SB7FF	SB000 ~ SB7F0		
Timer (contact)	TS00000 ~ TS23087	-----		
Timer (coil)	TC00000 ~ TC23087	-----		
Aggregation Timer (contact)	SS00000 ~ SS23087	-----		
Aggregation Timer (coil)	SC00000 ~ SC23087	-----		
Counter (contact)	CS00000 ~ CS23087	-----		
Counter (coil)	CC00000 ~ CC23087	-----		
Timer (current value)	-----	TN00000 ~ TN23087		
Aggregation Timer (current value)	-----	SN00000 ~ SN23087		
Counter (current value)	-----	CN00000 ~ CN23087		
Data Register	-----	 D00000 ~ D25983		
Special Register	-----	SD0000 ~ SD2047		
Link Register	-----	W0000 ~ W657F		
Special Link Register	-----	SW000 ~ SW7FF		
File Register (normal)	-----	R00000 ~ R32767	 *1	
File Register (serial)	-----	0R0000 ~ 0R7FFF	 *1	
	-----	1R0000 ~ 1R7FFF	 *1	
	:	:	:	
	-----	31R0000 ~ 31R67FF	 *1	

*1 When using the File Register, a Memory Card is necessary. Depending on the Memory Card being used, the File Register's device range differs.



• The device ranges given here are based on the maximum values possible for parameter settings.

5.1.4 Environment Setup

The following lists Digital's recommended PLC and GP communication settings.

■ MELSEC-A Series (When using Computer Link I/F)

GP Setup		PLC (Data Register) Setup	
Baud Rate	19200 bps	Baud Rate	19200
Data Length	7 bit	Data Length	7 bit
Stop Bit	2 bit	Stop Bit	2 bit
Parity Bit	Even	Parity Check Parity setting even/odd	Yes Even
Data Flow Control	ER Control	-----	
Communication Format	4-wire type	Channel setup	RS-422
		Mode Setup	8 (Format 4 protocol)
	-----	Write during RUN	Yes
	-----	Sumcheck	Yes
	-----	Transmission area terminal resistance	Present
	-----	Receiving area terminal resistance	Present
Unit No.	0	Station No.	0

■ MELSEC-FX Series (FX_{2N})

GP Setup		PLC (Data Register) Setup	
Baud Rate	19200 bps	Baud Rate	19200
Data Length	7	Data Length	7
Stop Bit	2	Stop Bit	2
Parity Bit	Even	Parity Bit	Even
Data Flow Control	ER Control	-----	
Communication Format	4-wire type	Computer Link	RS485(RS422) I/F
Station No.	0	Station No.	0
	-----	Sumcheck	Yes
	-----	Protocol	Yes
	-----	Mode	Format 4 protocol
	-----	Header	No
	-----	Terminator	No



PLC's Station NO. data must be written in data register D8121 and other settings must be written in data register D8120. For details refer to Mitsubishi's "FX Communication Users Manual".

■ MELSEC-QnA Series

GP Setup		PLC (Data Register) Setup	
Baud Rate	19200 bps *1	Baud Rate	19200
Data Length	7 bit	Data Length	7 bit
Stop Bit	2 bit	Stop Bit	2 bit
Parity Bit	Even	Parity Check	Yes
		Parity setting even/odd	Even
Data Flow Control	ER Control	-----	
Communication Format	4-wire type	Mode Setup	4 (Format 4 protocol)
	-----	Sumcheck	Yes
	-----	Transmission area terminal resistance	Present
	-----	Receiving area terminal resistance	Present
Unit No.	0	Station No.	0

*1 AJ71QC24N-R4, AISJ71QC24N, AJ71QC24N can use a baud rate of 115.2kbps.



- CH1 and CH2 of a serial communication unit can communicate at the same time, given any of the following conditions.
- Refer to the MELSEC A Series table when using environment with MELSEC QnA and Computer Link I/F AJ71UC24 together.

Condition 1 : The sticker on the top of the communication unit indicates the version is AB or later.

Condition 2 : The date shown on the side of the communication unit indicates it was produced in September 1996 (9609) or later.

Condition 3 : The communication ROM version is 7179M or later.

■ MELSEC-Q Series (using A Mode CPU Computer Link Unit)

GP Setup		Computer Link Unit Settings	
Baud Rate	19200 bps (fixed)	Baud Rate	19200 bps
Data Length	7 bits (fixed)	Data Length	7 bits
Stop Bit	2 bits (fixed)	Stop Bit	2 bits
Parity Bit	Even	Parity Check	Yes
		Parity setting even/odd	Even
Data Flow Control	ER Control	-----	
Communication Format (RS-422)	4-wire type	Mode Setup (RS-422)	8 (Format 4 Protocol Mode)
	-----	Write possible in RUN mode	Possible
	-----	Sumcheck	Yes
Unit No.	0 (fixed)	Station No.	0

■ MELSEC-Q Series (Q Mode CPU Serial Communication Unit)

GP Setup		Serial Communication Unit Settings *1	
Baud Rate	19200 bps	Baud Rate	19200 bps
Data Length	7 bits	Data Length	7 bits
Stop Bit	2 bits	Stop Bit	2 bits
Parity Bit	Even	Parity Check Parity setting even/odd	Yes Even
Data Flow Control	ER Control	-----	
Communication Format (RS-422)	4-wire type	Mode Setup (RS-422)	4 (Format 4 Protocol Mode)
-----		Sumcheck	Yes
Unit No.	0	Station No.	0

*1 The setting is made by Mitsubishi's GPP function software.

5.2 OMRON

5.2.1 System Structure



The following describes the system structure for connecting the GP to Omron PLCs.

Reference The Cable Diagrams mentioned in the following tables are listed in the section titled "5.2.2 Cable Diagrams".

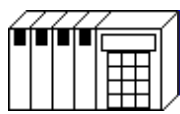

If the PLC is used in RUN mode, "PLC COM. ERROR (02: 01)" may appear. The GP subsequently forces the PLC to enter MONITOR mode (data can be written to the PLC only while it is in RUN mode); data communications will not be affected.

■ SYSMAC C Series (using Link I/F)

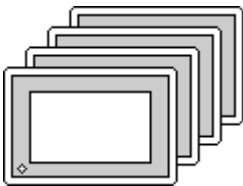
CPU	Link I/F	Cable Diagram	GP
	 Upper Link Unit		
C 200H	C 200H-LK202 ^{*1} C 120-LK202-V1 ^{*2}	RS-422 (Cable Diagram 1)	GP Series
C 200HS	C 200H-LK202 ^{*1}		
C 500, C 500F, C 1000H, C 2000,	C 120-LK202-V1 ^{*2} C 500-LK201-V1 ^{*1}		
C 2000H	C 500-LK203 ^{*1}	RS-422	
C 1000HF	C 500-LK203 ^{*1}	(Cable Diagram 2)	
C 120, C 120F	C 120-LK202-V1 ^{*2}	RS-422 (Cable Diagram 1)	
SRM1-C02 CPM1-20CDR-A CPM2A	CPM1-CIF11	RS-422 (Cable Diagram 5)	



* 1 Base installation type.

* 2 Connected to the CPU.



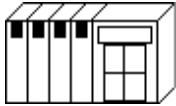

When you wish to run communications at a high speed, use the upper Link I/F (CPU type) C120-LK202-V1.

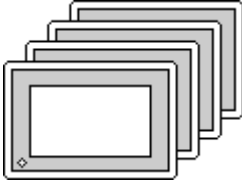

■ SYSMAC-α Series (using Link I/F)

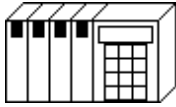
CPU	Link I/F	Cable Diagram	GP
	Communication Board 		
C200HX-CPU64, C200HG-CPU43, C200GE-CPU42	C200HW-COM06	RS-422 (Cable Diagram 3)	GP series
C200HX-CPU64-Z	C200H-LK202-V1	RS-422 (Cable Diagram 1)	

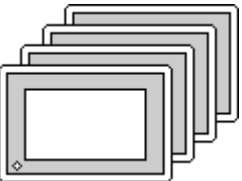
■ SYSMAC CV Series (using Link I/F and CPU Unit Link I/F)

CPU	Link I/F	Cable Diagram	GP
	Communication Board 		
CV500, CV1000, CVM1	CV500-LK201 CPU Unit Link I/F	RS-422 (Cable Diagram 4)	GP series

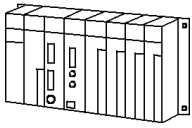
■ SYSMAC CS1 Series < using Link I/F >

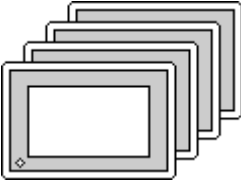
CPU	Link I/F	Cable Diagram	GP
			
CS1H-CPU67 CS1H-CPU66 CS1H-CPU65 CS1H-CPU64 CS1H-CPU63 CS1G-CPU45 CS1G-CPU44 CS1G-CPU43 CS1G-CPU42	CS1W-SCB41	RS-422(Port 2) (Cable Diagram 6)	GP Series

5.2.2 Cable Diagrams

The cable diagrams shown below and the cable diagrams recommended by Omron may differ, however, using these cables for your PLC operations will not cause any problems.

Cable Diagram 1

- When using Digital's RS-422 connector terminal adapter GP070-CN10-O

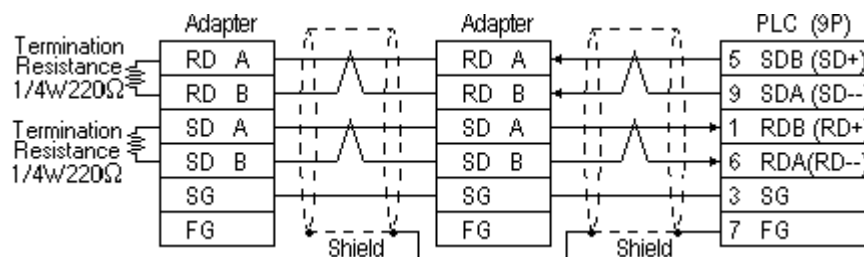

- When using Digital's Multi-link Cable, GP230-IS12-O

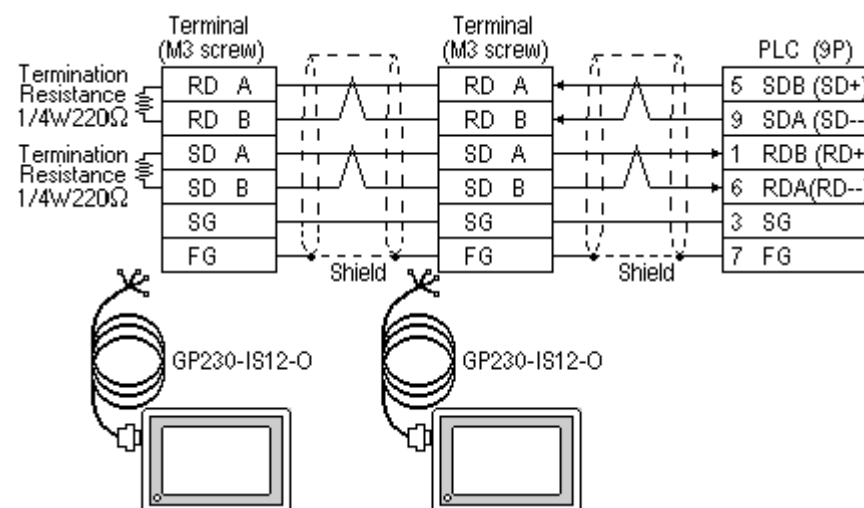

Ground your PLC's FG terminal according to your country's applicable standard. For details, refer to the corresponding PLC manual.



- Pull out a small amount of the Transfer Cable's shield, make a wire out of it and connect it to the PLC's FG terminal.
- The GP230-IS12-O Cable FG terminal is not connected to the GP's FG.
- Be aware the A and B signals of the GP and PLC are opposite to each other.
- Place a Termination Resistor where the GP and PLC are positioned at either end of the cable. The Termination Resistor is automatically setup when the PLC's Termination Resistor switch is turned ON.



- For the RS-422 connection, use a cable length less than 500m.
- As a general rule, connect the PLC at either end of the circuit.

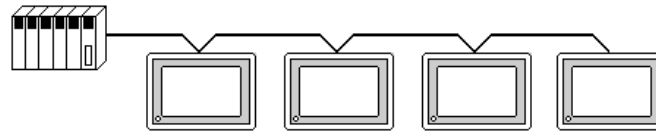

When making your own cable connections, we recommend using Hirakawa Densen's H-9293A (CO-HC-ESV-3P*7/0.2).

The cable connection lines are as illustrated below. The cables between the GP and the terminals should be less than 10 meters.

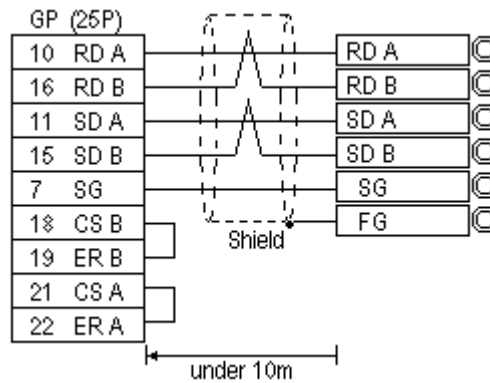

Cable Diagram 2

- When using Digital's RS-422 connector terminal adapter GP070-CN10-O

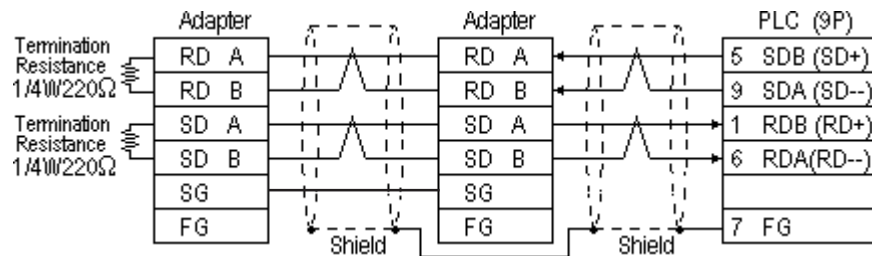

- When using Digital's Multi-link Cable, GP230-IS12-O

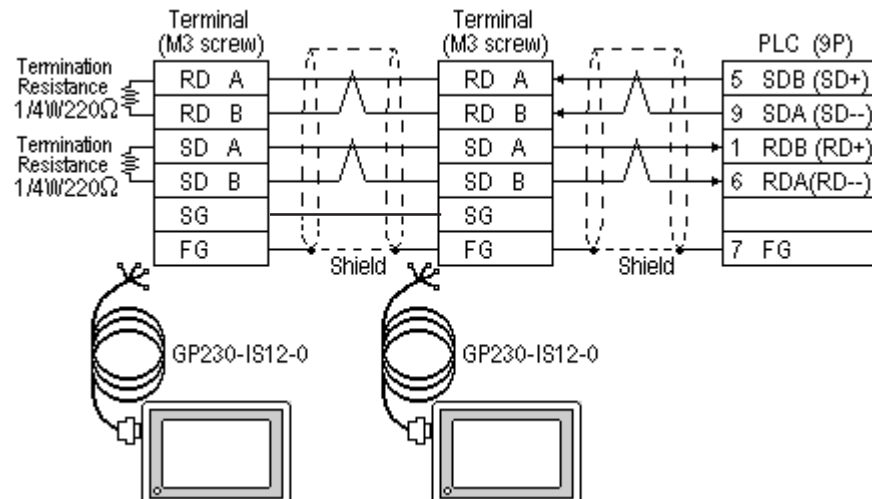



Ground your PLC's FG terminal according to your country's applicable standard. For details, refer to the corresponding PLC manual.



- Pull out a small amount of the Transfer Cable's shield, make a wire out of it and connect it to the PLC's FG terminal.
- The GP230-IS12-O Cable FG terminal is not connected to the GP's FG.
- Be aware the A and B signals of the GP and PLC are opposite to each other.
- Place a Termination Resister at both ends of the cable. The termination Resister is automatically setup when the PLC's Termination Resister switch is turned ON.
- As a general rule, connect the PLC at either end of the circuit.

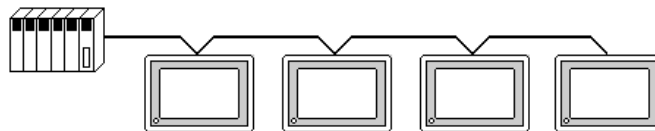

When making your own cable connections, we recommend using Hiramawa Densen's H-9293A (CO-HC-ESV-3P*7/0.2).

The cable connection lines are as illustrated below. The cables between the GP and the terminals should be less than 10 meters.

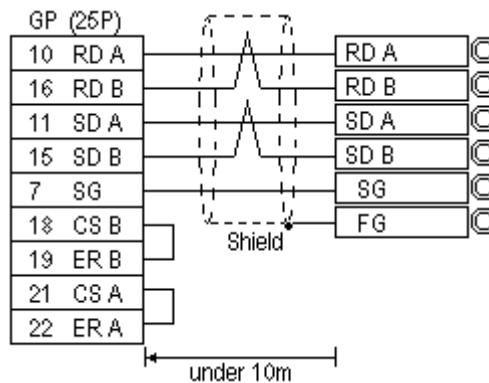

Cable Diagram 3

- When using Digital's RS-422 connector terminal adapter GP070-CN10-O

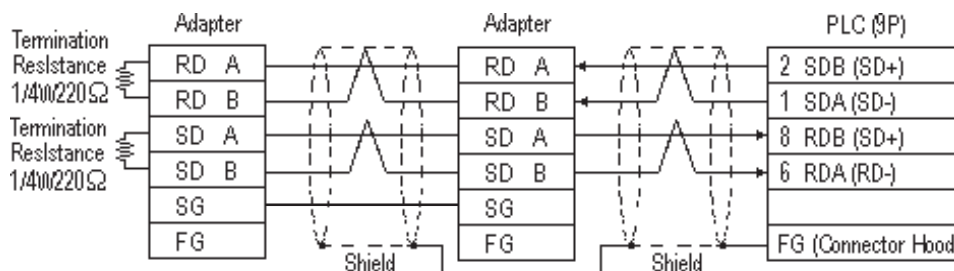

- When using Digital's Multi-link Cable, GP230-IS12-O

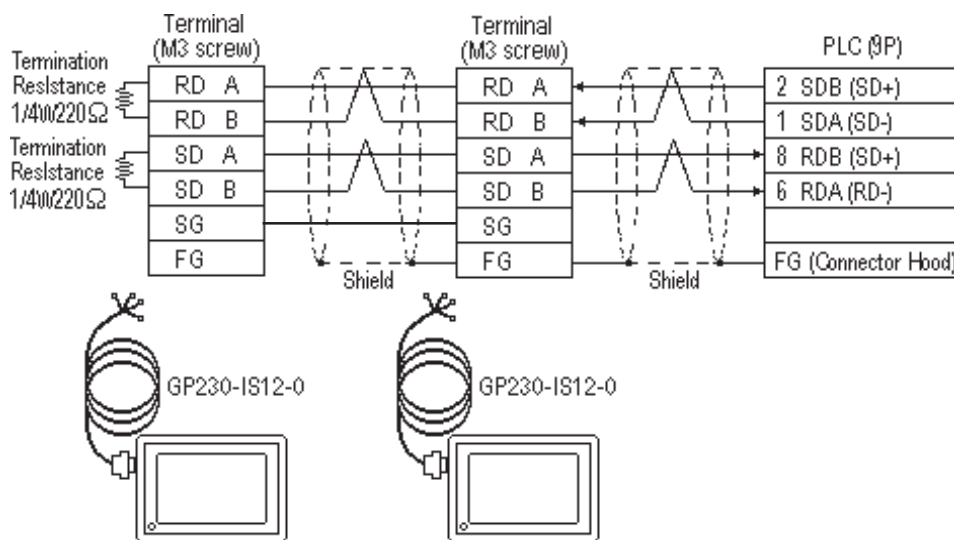

Ground your PLC's FG terminal according to your country's applicable standards. For details, refer to the corresponding PLC manual.



- Pull out a small amount of the Transfer Cable's shield, make a wire out of it and connect it to the PLC's FG terminal.
- The GP230-IS12-O Cable FG terminal is not connected to the GP's FG.
- Be aware the A and B signals of the GP and PLC are opposite to each other.
- Place a Termination Resistor at both ends of the cable. The Termination Resistor is automatically setup when the PLC's Termination Resistor switch is turned ON.
- As a general rule, connect the PLC at one end of the circuit.





Note: When making your own cable connections, we recommend using Hirakawa Densen's H-9293A (CO-HC-ESV-3P*7/0.2).

The cable connection lines are shown below. The cables between the GP and the terminals should be less than 10 meters.

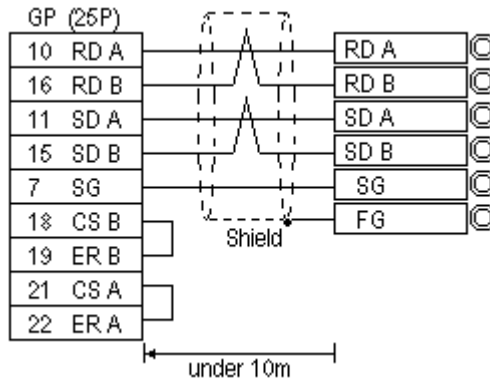

Cable Diagram 4

- When using Digital's RS-422 connector terminal adapter GP070-CN10-O

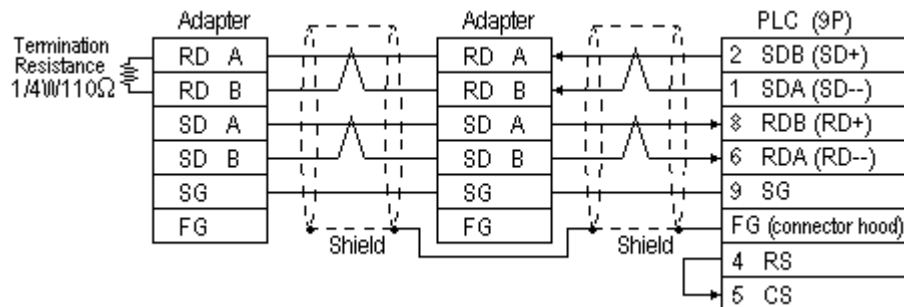

- When using Digital's Multi-link Cable, GP230-IS12-O

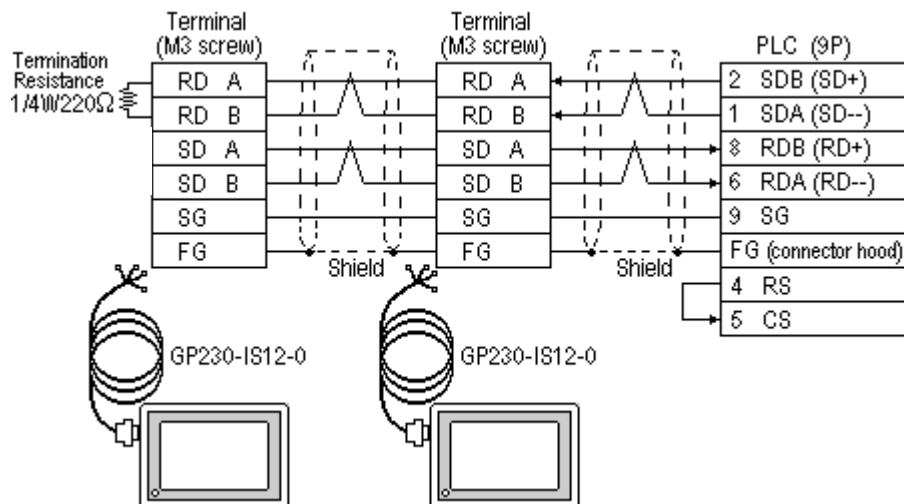



Ground your PLC's FG terminal according to your country's applicable standards. For details, refer to the corresponding PLC manual.



- Pull out a small amount of the Transfer Cable's shield, make a wire out of it and connect it to the PLC's FG terminal.
- Setup the PLC's RS-232C/422 toggle switch as RS-422.
- An Omron connector (XM2A-0901) and connector hood (XM2S-0911) is included with each CV500/CV1000 CPU unit. Other connectors are not compatible.
- The GP230-IS12-O Cable FG terminal is not connected to the GP's FG.
- Be aware the A and B signals of the GP and PLC are opposite to each other.
- Place a Termination Resistor at both ends of the cable. The Termination Resistor is automatically setup when the PLC's Termination Resistor switch is turned ON.
- As a general rule, connect the PLC at one end of the circuit.

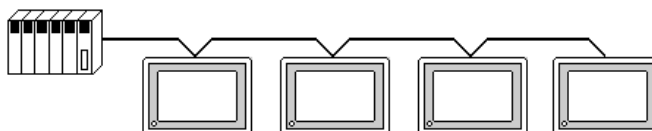

When making your own cable connections, we recommend using Hirakawa Densen's H-9293A (CO-HC-ESV-3P*7/0.2).

The cable connection lines are as illustrated below. The cables between the GP and the terminals should be less than 10 meters.

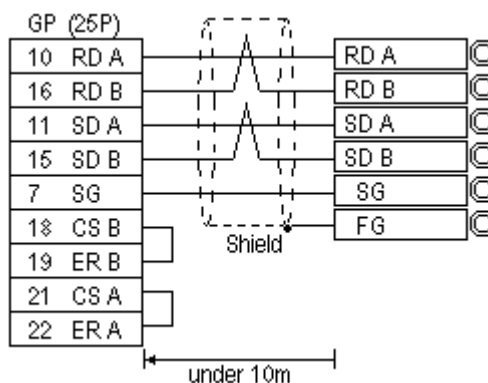

Cable Diagram 5

- When using Digital's RS-422 connector terminal adapter GP070-CN10-O

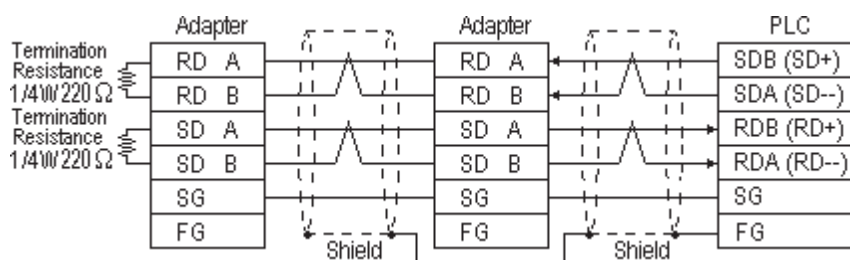

- When using Digital's Multi-link Cable, GP230-IS12-O

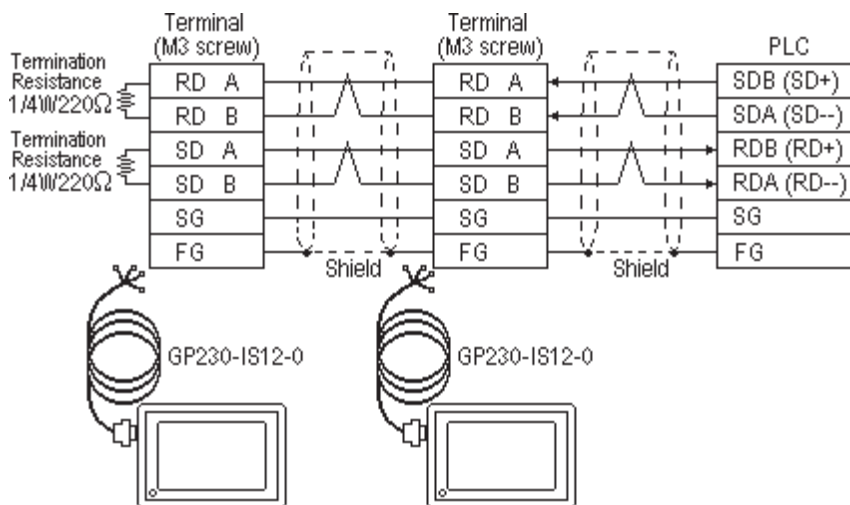

Ground your PLC's FG terminal according to your country's applicable standards. For details, refer to the corresponding PLC manual.



- **Pull out a small amount of the Transfer Cable's shield, make a wire out of it and connect it to the PLC's FG terminal.**
- **Be aware the A and B signals of the GP and PLC are opposite to each other.**
- **Place a Termination Resistor at both ends of the cable. The Termination Resistor is automatically setup when the PLC's Termination Resistor switch is turned ON.**
- **As a general rule, connect the PLC at one end of the circuit.**

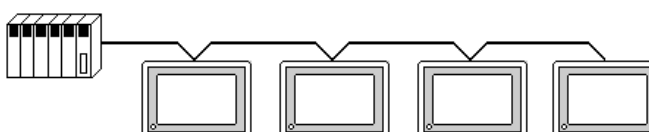



Note: When making your own cable connections, we recommend using Hirakawa Densen's H-9293A (CO-HC-ESV-3P*7/0.2).

The cable connection lines are shown below. The cables between the GP and the terminals should be less than 10 meters.

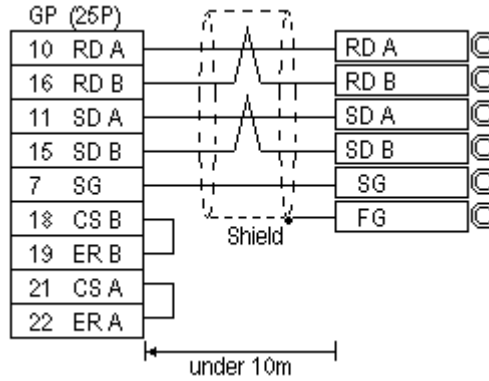

Cable Diagram 6

- When using Digital's RS-422 connector terminal adapter GP070-CN10-0

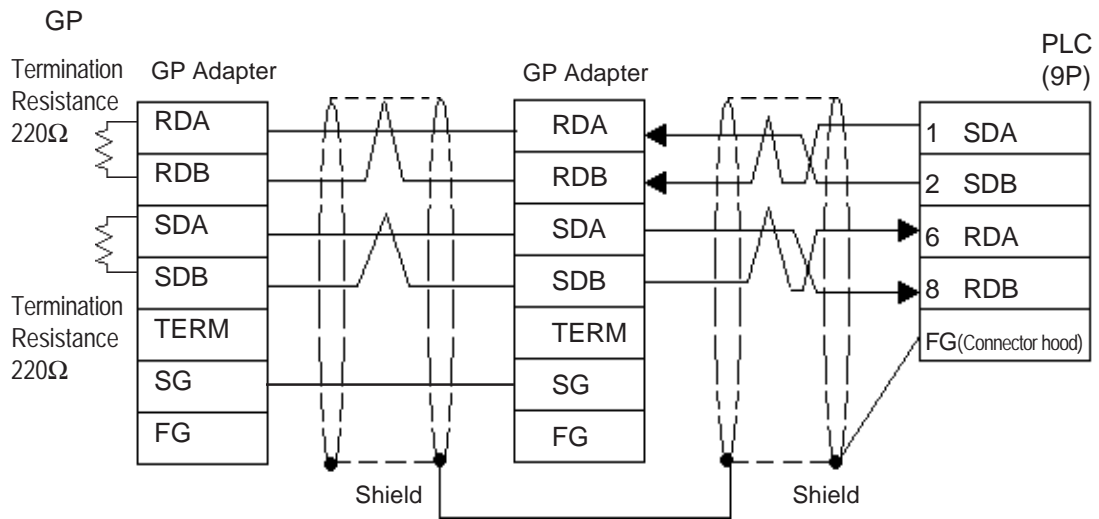

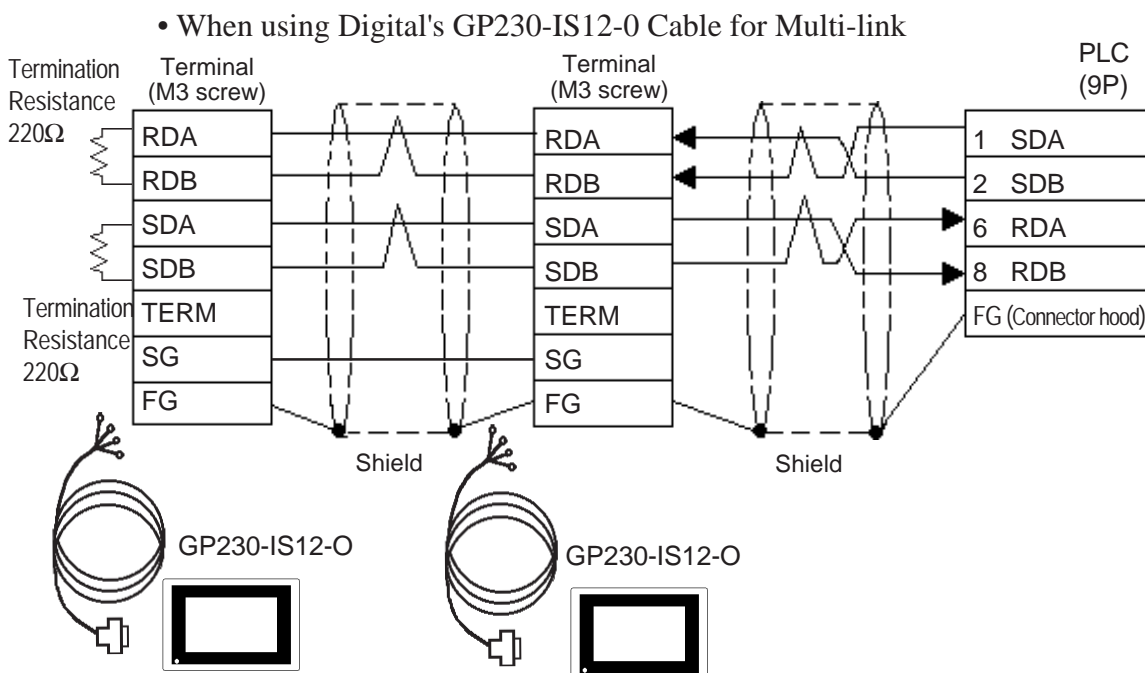

- When making your own cable instead of using GP230-IS12-0

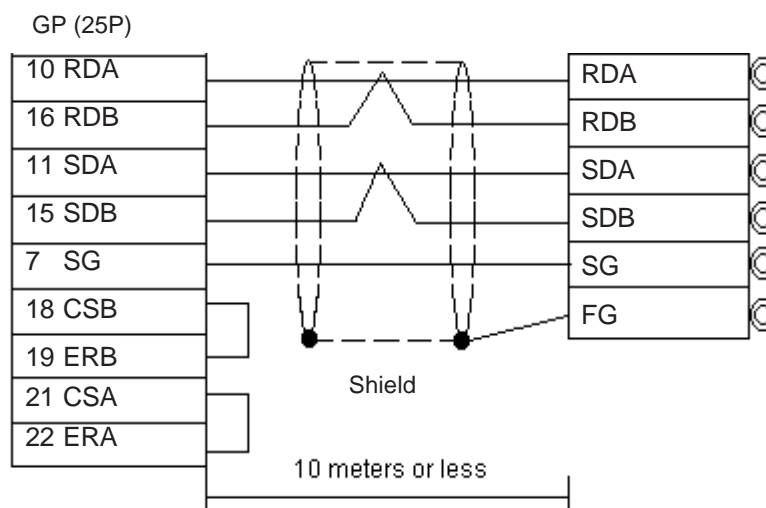

- Note:**
- Pull out a small amount of the Transfer Cable's shield, make a wire out of it and connect it to the PLC's FG terminal.
 - GP230-IS12-0 cable's FG terminal is not connected to GP's FG terminal.
 - Be aware the A and B signals of the GP and PLC are opposite to each other.
 - Place a Termination Resistor where the GP and PLC are positioned at either end of the cable.
 - The PLC's termination resistance will be automatically set when the board's Termination Resistance Switch is turned ON.
 - As a general rule, connect the PLC on either end of the circuit.
 - RS-422 cables must be 500 meters or less.
 - The Hiramkawa Hewtech's CO-HC-ESV-3PX7/0.2 cable is recommended for this connection.

5.2.3 Supported Devices

The following describes the range of devices supported by the GP.

■ SYSMAC C Series

 Setup System Area or Communication Information's Storing Address here.

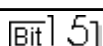
Device	Bit Address	Word Address	Particulars	
I/O Relay	00000 ~ 51115	000 ~ 511		
Internal Hold Relay				
Analog Setup Value Storage Area	22000~ 22315	220 ~ 223		
Data Link Relay	LR0000 ~ LR6315	LR00 ~ LR63		
Special Hold Relay	24400 ~ 25515	244 ~ 255	*1	
Auxiliary Memory Relay	AR0000 ~ AR2715	AR00 ~ AR27	L/H	
Hold Relay	HR0000 ~ HR9915	HR00 ~ HR99		
Timer (contact)	TIM000 ~ TIM511	---		
Counter (contact)	CNT000 ~ CNT511	---		
Timer (current value)	---	TIM000 ~ TIM511		
Counter (current value)	---	CNT000 ~ CNT511		
Data Memory	---	DM0000 ~ DM9999		

* 1 Use the I/O Relay/Internal Hold Relay for setting up this data.



Note: The procedure for writing bits for T- and W-tags is different for the GP-*30, the GP-*50, and the GP-70 series units:

When performing the bit write operation (other than *Reverse*) using T and W tags on the GP-*30 Series, the corresponding word address, other than the selected bits, is cleared.



- The method of writing bits will differ depending on the GP series.
<GP-*30 series>

When the bit write operation (other than *Reverse*) is performed, the corresponding word address will set the bits to 0 (except the designated bits).

<Except GP-*30 series>

When the bit write operation is performed, the GP reads the PLC's corresponding word address and turns a bit ON, then send back to PLC. Do not write to the word address from the ladder program in the middle of this operation.

- When running a GP-*30 Series ladder program, be aware of the above points.

■ SYSMAC- α Series

 Setup System Area or Communication Information's Storing Address here.

Device	Bit Address	Word Address	Particulars
I/O Relay I	00000 ~ 02915	000 ~ 029	L/H
I/O Relay II	30000 ~ 30915	300 ~ 309	
Internal Hold Relay I	03000 ~ 23515	030 ~ 235	
Internal Hold Relay II	31000 ~ 51115	310 ~ 511	
Special Hold Relay I	23600 ~ 25507	236 ~ 255	
Special Hold Relay II	25600 ~ 29915	256 ~ 299	
Hold Relay	HR0000 ~ HR9915	HR00 ~ HR99	
Auxiliary Memory Relay	AR0000 ~ AR2715	AR00 ~ AR27	
Link Relay	LR0000 ~ LR6315	LR00 ~ LR63	
Timer (contact)	TIM000 ~ TIM511	---	
Counter (contact)	CNT000 ~ CNT511	---	
Timer (current value)	---	TIM000 ~ TIM511	
Counter (current value)	---	CNT000 ~ CNT511	
Data Memory	---	DM0000 ~ DM6655	



Note: The procedure for writing bits for T- and W-tags is different for the GP series.

When performing the bit write operation (other than *Reverse*) using T and W tags on the GP-*30 Series, the corresponding word address, other than the selected bits, is cleared.



The method of writing bits will differ depending on the GP series.

<GP-*30 series>

When the bit write operation (other than *Reverse*) is performed, the corresponding word address will set the bits to 0 (except the designated bits).

<Except GP-*30 series>

When the bit write operation is performed, the GP reads the PLC's corresponding word address and turns a bit ON, then send back to PLC. Do not write to the word address from the ladder program in the middle of this operation.

- When running a GP-*30 Series ladder program, be aware of the above points.

■ SYSMAC CV Series

 Setup System Area or Communication Information's Storing Address here.

Device	Bit Address	Word Address	Particulars	
I/O Relay	00000 ~ 19915	000 ~ 199		
Internal Hold Relay				
Sysmac BUS/2 Remote I/O Relay	020000 ~ 099915	0200 ~ 0999		
Data Link Relay	100000 ~ 119915	1000 ~ 1199		
Special Hold Relay	A00000 ~ A51115	A000 ~ A511		
Hold Relay	120000 ~ 149915	1200 ~ 1499		
Internal Aux. Relay	190000 ~ 229915	1900 ~ 2299	L/H	
SYSBUS Remote I/O Relay	230000 ~ 255515	2300 ~ 2555		
Timer (contact)	T0000 ~ T1023	---		
Counter (contact)	C0000 ~ C1023	---		
Timer (current value)	---	T0000 ~ T1023		
Counter (current value)	---	C0000 ~ C1023		
Data Memory	---	D0000 ~ D9999		<input type="text" value="Bit"/> <input type="text" value="5"/>



- Write operations cannot be performed on the Timer and Counter bit devices.
- Cannot use the Data Memory extended addresses (E).



- The procedure for writing bits for T- and W-tags is different for the GP series.
- When performing the bit write operation (other than *Reverse*) using T and W tags on the GP-*30 Series, the corresponding word address, other than the selected bits, is cleared.



- The method of writing bits will differ depending on the GP series.
 <GP-*30 series>
 When the bit write operation (other than *Reverse*) is performed, the corresponding word address will set the bits to 0 (except the designated bits).
 <Except GP-*30 series>
 When the bit write operation is performed, the GP reads the PLC's corresponding word address and turns a bit ON, then send back to PLC. Do not write to the word address from the ladder program in the middle of this operation.
- When running a GP-*30 Series ladder program, be aware of the above points.

■ SYSMAC CS1 Series

In this list, "Exp." means "Expansion".

 Setup System Area or Communication Information's Storing Address here.

Device	Bit Address	Word Address	Particulars	
Channel I/O	000000 ~ 614315	0000 ~ 6143		L/H
Internal Auxiliary Relay	W00000 ~ W51115	W000 ~ W511		
Hold Relay	H00000 ~ H51115	H000 ~ H511		
Special Auxiliary Relay	A00000 ~ A95915	A000 ~ A959	*1	
Timer(Contact)	T0000 ~ T4095	----	*3	
Counter(Contact)	C0000 ~ C4095	----	*3	
Timer(Current)	----	T0000 ~ T4095		
Counter(Current)	----	C0000 ~ C4095		
Data Memory	D0000000 ~ D3276715	D00000 ~ D32767	*2	
Exp. Data Memory (E0 ~ EC)	E00000000 ~ EC3276715	E000000 ~ EC32767	*4	
Exp. Data Memory (Current Bank)	----	EM00000 ~ EM32767	Bit 15	
Task Flag	----	TK0 ~ TK30	÷ 2 Bit 15 *3	
Index Register	----	IR0 ~ IR15	Bit 31 *3	
Data Register	----	DR0 ~ DR15	Bit 15 *3	

*1 Addresses A000 to A477 cannot be written to.

*2 When using the Communication Unit (CS1W-SCU21), addresses D30000 to D31599, since they are used for PLC system settings, should not be written to from the GP.

When using the Communication Board (CS1W-SCB21/41), addresses D32000 to D32767 are used for PLC settings, should not be written to from the GP.

*3 Cannot be written to.

*4 The range of Expansion Data Memory varies depending on the CPU type.

▼ **Reference** ▲ For details about each device, refer to Omron's SYSMAC CS1 Series Communication Board CS1W-SCB21-/41 Communication CS1W-SCU21 Users Manual.

5.2.4 Environment Setup

The following tables contain Digital's recommended PLC and GP communication settings. The recommended settings are for an RS-232C connection.

■ SYSMAC C Series

GP Setup		Upper Link Unit Setup	
Baud Rate	19200 bps	Baud Rate	19200 bps
Data Length	7 bits	Data Bit	7 bits
Stop Bit	2 bits	Stop Bit	2 bits
Parity Bit	Even	Parity Bit	Even
Data Flow Control	ER Control	---	
Communication Format	4-wire type	Communication Format	RS-422
---		Command Level	Level 1,2,3 is valid
---		Relation	1:N
---		DC +5V power supply	No
---		CTS Setup	Normally On
Unit. No.	0	Station Number	0

■ SYSMAC- α Series

GP Setup		PLC Setup	
Baud Rate	19200 bps	Baud Rate	19200 bps
Data Length	7 bits	Data Bit	7 bits
Stop Bit	2 bits	Stop Bit	2 bits
Parity Bit	Even	Parity Bit	Even
Data Flow Control	ER Control	---	
Communication Format	4-wire type	Change dip SW 1 to indicate either RS-422 or 485 cable (2-wire or 4-wire type)	4
Unit. No.	0	Station Number	0

■ SYSMAC CV Series

GP Setup		PLC Setup	
Baud Rate	19200 bps	Baud Rate	19200 bps
Data Length	7 bits	Data Bit	7 bits
Stop Bit	2 bits	Stop Bit	2 bits
Parity Bit	Even	Parity Bit	Even
Data Flow Control	ER Control	---	
Communication Format	4-wire type	Communication Format	RS-422
Unit. No.	0	Station Number	0

■ SYSMAC CS1 Series

GP Setup		PLC Setup	
Baud Rate	19200	Baud Rate	19200
Data Length	7	Data Length	7
Stop Bit	2	Stop Bit	2
Parity Bit	Even	Parity Bit	Even
Data Flow Control	ER	-	-
Communication Format (using RS422)	4-wire type	WIRE (2-wire/4-wire type Switch)	4-wire type
-	-	TERM (Termination Resistance Switch)	Termination Resistance ON
Unit.No	0	Upper Link Station No.	0
-	-	Serial Communication mode	Upper Link
-	-	Communication Delay Time	0
-	-	CTS Control	None



5.3 Hitachi



5.3.1 System Structure

The following describes the system structure for connecting the GP to Hitachi PLCs.

Reference The Cable Diagrams mentioned in the following tables are listed in the section titled "5.3.2 Cable Diagrams".

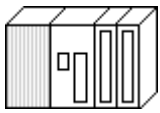
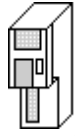

■ HIDIC H Series (using Link I/F)

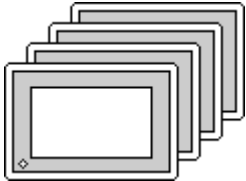
Procedure 1 for transmission control

CPU	Link I/F	Cable Diagram	GP
	 COMM Module		
H-2000 (CPU-20Ha), H-2002 (CPU2-20H) H-302 (CPU2-03H) H-702 (CPU2-07H) H-4010 (CPU3-40H)	COMM-H COMM-2H COMM-2H	(Cable Diagram 1)	GP Series

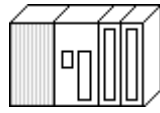
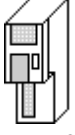

■ HIDIC H Series/COMM-2H (using Link I/F)

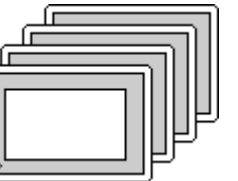
Procedure 2 for transmission control

CPU	Link I/F	Cable Diagram	GP
	 COMM Module		
H-302 (CPU2-03H) H-702 (CPU2-07H) H-2000 (CPU-20Ha) H-2002 (CPU-20H)	COMM-2H	(Cable Diagram 1)	GP Series

■ **HIDIC H Series** (CPU Direct Connection)

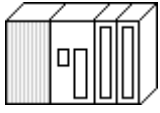
Procedure 1 for transmission control

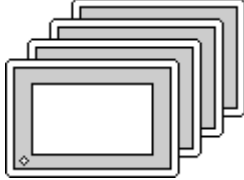
CPU	Cable Diagram	GP
		
EH-150 (EH-CPU448) *1 *2	(Cable Diagram 2)	GP Series

*1 Connect to the CPU module's Serial Port 1.

*2 When connecting to a GP, a Hitachi EH-RS05, a conversion cable is required between the modular jack (8-pin) and the Dsub connector (5-pin) are required.

5.3.2 Cable Diagrams

The cable diagrams illustrated below and the cable diagrams recommended by Hitachi Ltd. may differ, however, using these cables for PLC operation will not cause any problems.

Cable Diagram 1

- When using Digital's RS-422 connector terminal adapter GP070-CN10-O

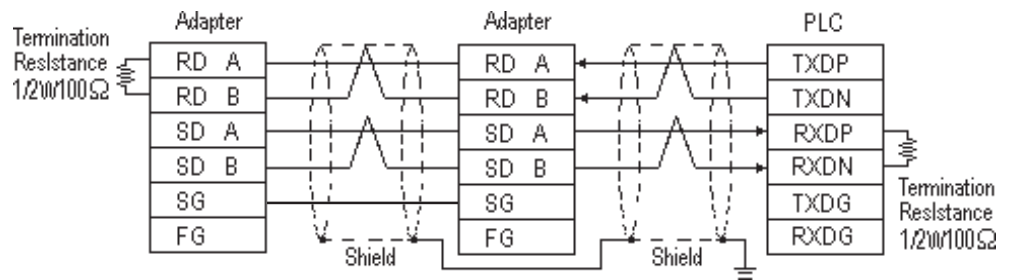

- When using Digital's Multi-link Cable, GP230-IS12-0

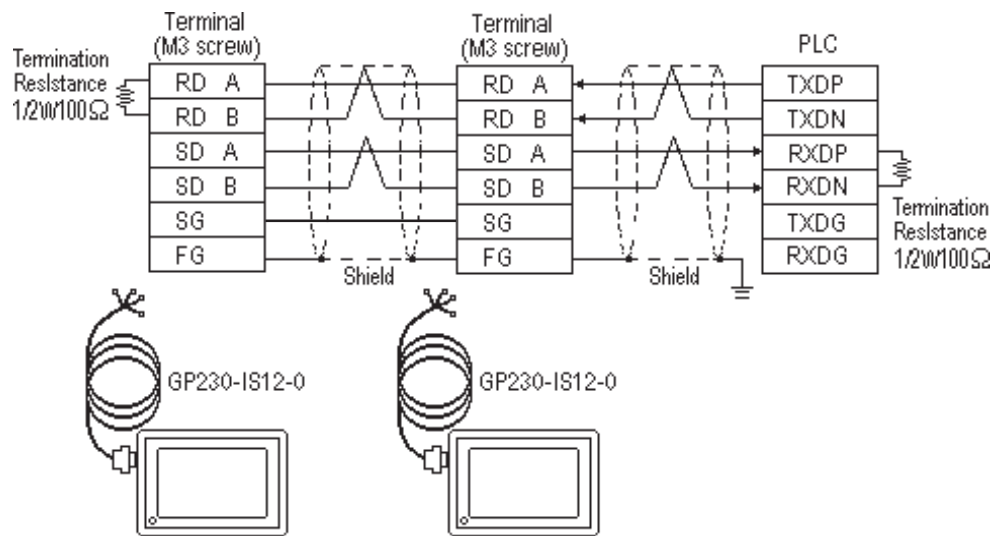

Cable Diagram 2

- When using Digital's RS-422 connector terminal adapter GP070-CN10-O

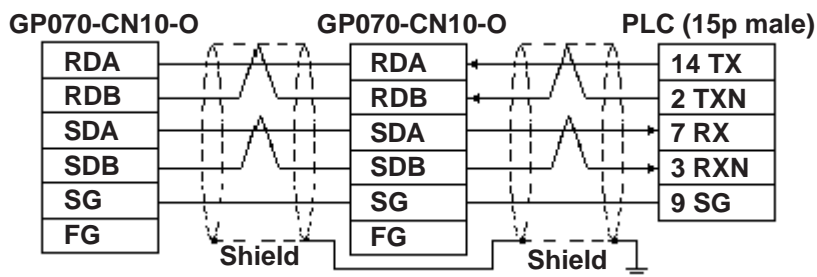

- When using Digital's Multi-link Cable, GP230-IS12-O

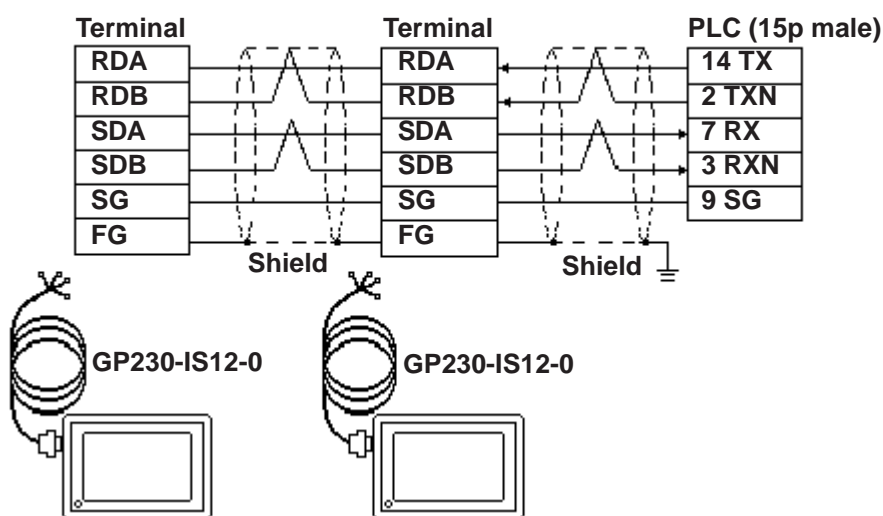

Ground your PLC's FG terminal according to your country's applicable standard. For details, refer to the corresponding PLC manual.



- Pull out a small amount of the Transfer Cable's shield, make a wire out of it and connect it to the PLC's FG terminal.
- The GP230-IS12-O Cable FG terminal is not connected to the GP's FG.
- Place a Termination Resistor at both ends of the cable.
- When using the COMM module, set its mode No. to "2".
- If an error occurs during data transmission, the program will be "retried" (resent), thereby delaying the occurrence/display of a transmission error until the retrying is finished.
- If the GP and the PLC's program consoles are operated simultaneously, the GP may generate a [Host SIO error (02: 37)] and the GPCL may generate a [CPU Exclusive Use Error]. In this case, the GP will automatically restart. The GPCL should be restarted.
- For the RS-422 connection, use a cable length less than 250m.



- As a general rule, connect the PLC at one end of the circuit.

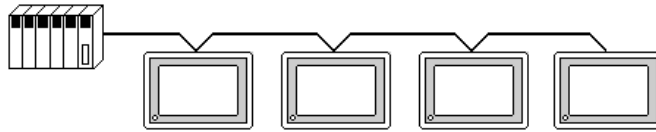

- When making your own cable connections, we recommend using Hitachi Densen's KPEV-SB-3P 0.5 mm².

The cable connection lines are as illustrated below. The cables between the GP and the terminals should be less than 10m.

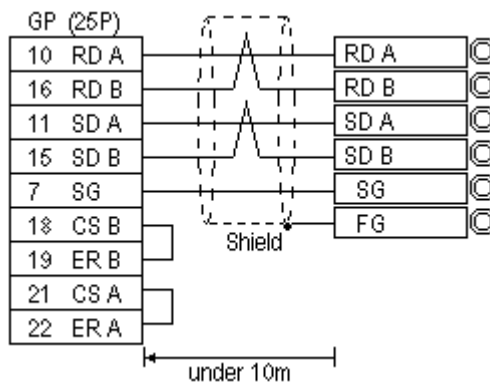

5.3.3 Supported Devices

The following describes the range of devices supported by the GP.

■ HIDIC H (HIZAC H) Series

 Setup System Area or Communication Information's Storing Address here.

Device	Bit Address	Word Address	Particulars
External Input	X00000 - X05A95	WX0000 - WX05A7	*1
External Output	Y00000 - Y05A95	WY0000 - WY05A7	*1
Remote Input Relay	X10000 - X49A95	WX1000 - WX49A7	*1
Remote Output Relay	Y10000 - Y49A95	WY1000 - WY49A7	*1
Internal Output	R000 - R7BF	---	
CPU Link Area 1	L0000 - L3FFF	WL000 - WL3FF	
CPU Link Area 2	L10000 - L13FFF	WL1000 - WL13FF	
Data Area	M0000 - M3FFF	WM000 - WM3FF	
On Delay Timer	TD000 - TD1023	---	
Single Shot Timer	SS000 - SS1023	---	
Watch Dog Timer	WDT000 - WDT1023	---	
Monostable Timer	MS000 - MS1023	---	
Accumulation Timer	TMR000 - TMR1023	---	
Up Counter	CU000 - CU2047	---	
Ring Counter	RCU000 - RCU2047	---	
Up/Down Counter	CT000 - CT2047	---	
Timer/Counter (Elapsed Time)	---	TC000 - TC2047	
Word Internal Output	---	WR0000 - WRC3FF	
Network Link Area	---	WN0000-WN7FFF	Bit F

L/H

*1 Write the data as follows.

E.g. External Input unit No. 1, Slot No. 2, Module Bit No. 34

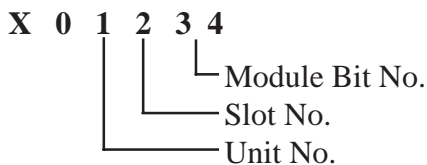

E.g. External Input unit No. 1, Slot No. 2, Module Word No. 3.

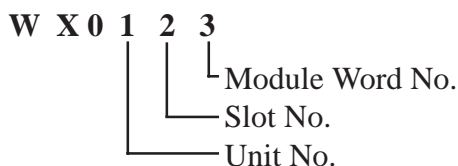



If the first CPU link (L0000 to L3FFF) and the second CPU link (L10000 to L13FFF) are used with any GP-PRO/PB III for Windows drawing software Ver. 1.0, enter L00000 to L03FFF for the first CPU link; and enter L100000 to L103FFF for the second CPU link by adding a zero to each one.

If you use Ver. 2.0 or later GP-PRO/PB III for Windows screen editor software is used, enter the addresses shown in the previous page's table.

If you upgrade your GP-PRO/PB III for Windows Ver. 1.0 software to Ver. 2.0 or later, your internal data will not be affected. Only the input method will change.

5.3.4 Environment Setup

The following lists Digital's recommended PLC and GP communication settings.

■ HIDIC H Series Procedure 1 for transmission control

GP Setup		COMM Module Setup	
Baud Rate	19200 bps	Baud Rate	19200 bps
Data Length	7 bits	Data Bit	7 bits
Stop Bit	1 bit	Stop Bit	1 bit
Parity Bit	Even	Parity Bit	Even
Data Flow Control	ER Control	---	
Communication Format	4-wire type	Channel Setup Mode Setup	RS-422 2
---		Sum Check	Yes
Unit. No.	1	Station Number Setting	1

■ HIDIC H Series/COMM-2H Procedure 2 for transmission control

GP Setup		COMM Module Setup	
Baud Rate	19200 bps	Baud Rate	19200 bps
Data Length	7 bits	Data Bit	7 bits
Stop Bit	1 bit	Stop Bit	1 bit
Parity Bit	Even	Parity Bit	Even
Data Flow Control	ER Control	---	
Communication Format	4-wire type	Channel Setup Mode Setup	RS-422 9
---		Sum Check	Yes
Unit. No.	1	Station Number Setting	1

■ **HIDIC EH150 Series** Procedure 1 for transmission control

GP Setup		PLC Setup	
Baud Rate	19200 bps	Baud Rate ^{*1}	19200 bps
Data Length	7 bits	Data Bit	7 bits
Stop Bit	1 bit	Stop Bit	1 bit
Parity Bit	Even	Parity Bit	Even
Data Flow Control	ER Control	---	
Communication Format	4-wire type	Mode Setting Switch	SW1 : OFF (Normal mode)
			SW5 : ON (Exclusive mode)
			SW7 : OFF (Normal Operation mode)
			SW8 : OFF (Normal Operation mode)
---		Exclusive Port Setting	Special Internal Output set to WRF037 ^{*3}
Unit No.	0	---	

*1 Set the Mode Setting Switch. (SW3, 4 : Port 1 setting)

*2 Depending on the your Interface and Procedure, varies as shown below.
 RS-422 Procedure 1 with unit No. : A1xxH (xx indicates GP's Unit No.)
 RS-422 Procedure 2 with unit No. : E1xxH (xx indicates GP's Unit No.)



5.4 Matsushita Electric

5.4.1 System Structure

The following describes the system structure for connecting the GP to Matsushita Electric PLCs.

Reference The Cable Diagrams mentioned in the following tables are listed in the section titled "5.4.2 Cable Diagrams".

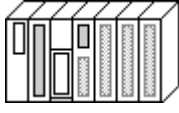
MEWNET Series (using CPU unit Link I/F)

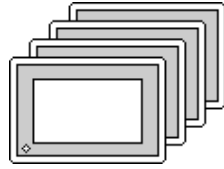
CPU	Cable Diagram	GP
		
FP10S (Ver 1.8+) *1 FP10SH	(Cable Diagram 1)	GP Series

*1 Connect to COM port.

An RS-232C/422 adapter is necessary (see below) for connections. Use the RS-232C/422 adapter's 422 side as the terminal, and power other than from the communication line, obtained externally.

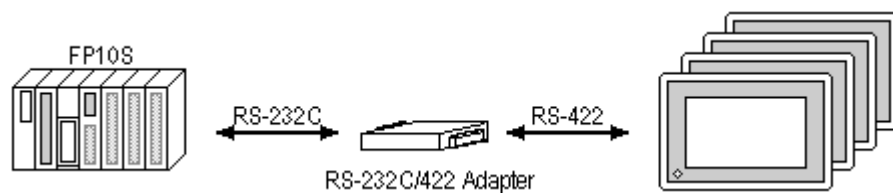

5.4.2 Cable Diagrams

The cable diagrams illustrated below and the cable diagrams recommended by Matsushita Electric may differ, however, using these cables for your PLC operations will not cause any problems.

Cable Diagram 1

- When using Digital's RS-422 connector terminal adapter GP070-CN10-O

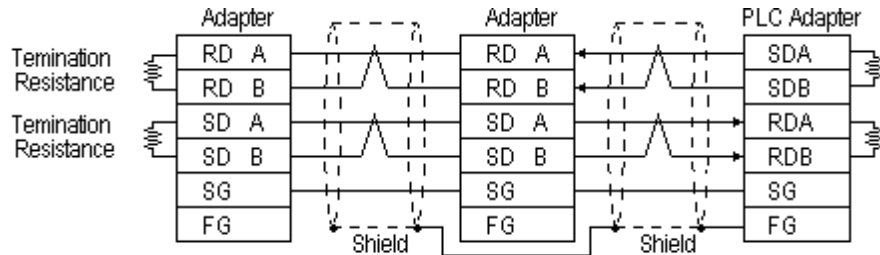

* Check the PLC Adapter specifications for the Termination Resistance

- When using Digital's Multi-link Cable, GP230-IS12-O

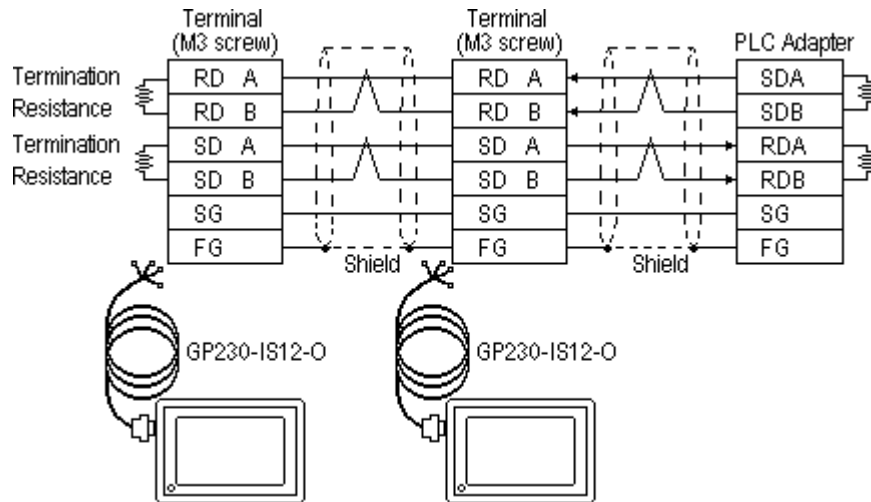

* Check the PLC Adapter specifications for the Termination Resistance



Ground your PLC's FG terminal according to your country's applicable standard. For details, refer to the corresponding PLC manual.



- **Pull out a small amount of the Transfer Cable's shield, make a wire out of it and connect it to the PLC's FG terminal.**
- **The GP230-IS12-O Cable FG terminal is not connected to the GP's FG.**
- **Be aware the A and B signals of the GP and PLC are opposite to each other.**
- **Place a Termination Resistor at bothe ends of the cable.**
- **As a general rule, connect the PLC on one end of the circuit.**

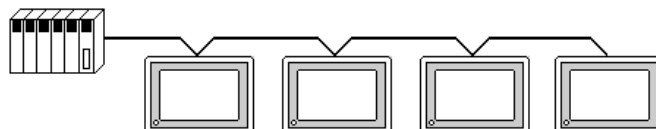



- When making your own connections, Hitachi Densen's CO-SPEV-SB(A)3P*0.5 cable is recommended.

The cable connection lines are as illustrated below. The cables between the GP and the terminals should be less than 10m.

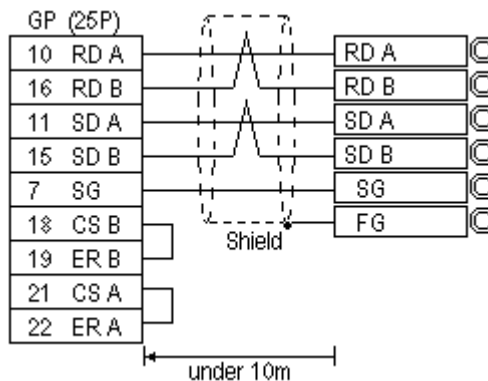

5.4.3 Supported Devices

The following describes the range of devices supported by the GP.

MEWNET Series

Setup System Area here.

Device	Bit Address	Word Address	Particulars
Input Relay	X0000 ~ X511F	WX000 ~ WX511	*1
Output Relay	Y0000 ~ Y511F	WY000 ~ WY511	
Internal Relay	R0000 ~ R886F	WR000 ~ WR886	
Link Relay	L000 ~ L639F	WL000 ~ WL639	
Special Relay	R9000 ~ R910F	WR900 ~ WR910	*1
Timer (contact)	T0000 ~ T3071	---	*1
Counter (contact)	C0000 ~ C3071	---	*1
Timer/Counter (elapsed time)	---	EV0000 ~ EV3071	*1
Timer/Counter (setup value)	---	SV0000 ~ SV3071	*1
Data Register	---	DT0000 ~ DT10239	Bit 15 *2
Link Register	---	Ld0000 ~ Ld8447	Bit 15
File Register	---	FL00000 ~ FL32764	Bit 15
Special Data Register	---	DT90000~DT90511	Bit 15 *3

*1 Cannot perform data write.

*2 Some CPU types use this device's word address DT09000 and higher as the Special Data Register.

*3 Only the FP10SH, FP10S, FP10 and FP2 can use this device.

5.4.4 Environment Setup

The following lists Digital's recommended PLC and GP communication settings.

■ FP10S/FP10SH

GP Setup		COM Port Setup	
Baud Rate	19200 bps	Baud Rate	19200 bps
Data Length	8 bits	Data Length	8 bits
Stop Bit	1 bit	Stop Bit	1 bit
Parity Bit	Odd	Parity Bit	Odd
Data Flow Control	ER Control		
Communication Format	4-wire type		
		Environ Task Allowable Time Setup	K5000
Unit No.	1	Unit No.	1



5.5 Yokogawa Electric

5.5.1 System Structure

The following describes the system structure for connecting the GP to Yokogawa Electric PLCs.

Reference The Cable Diagrams mentioned in the following tables are listed in the section titled "5.5.2 Cable Diagrams".

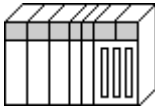
FACTORY ACE Series/FA-M3 (using Link I/F)

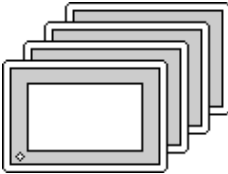
CPU	Link I/F	Cable Diagram	GP
	PC Link Unit 		
F3SP20-0N, F3SP21-0N, F3SP25-2N, F3SP28-3N, F3SP30-0N, F3SP35-5N, F3SP38-6N, F3SP53-4H, F3SP58-6H, F3SP36-3N	F3LC11-2N	With n:1 transmission *1 (Cable Diagram 1) With n:m transmission *1 (Cable Diagram 2)	GP Series

* 1 The diagram below shows the system configuration recommended to allow n:m data transmission, using the host link protocol, between the Yokogawa Electric PLC [FA-M3] (or equipment supporting the same protocol - m units), and the GP (n units).

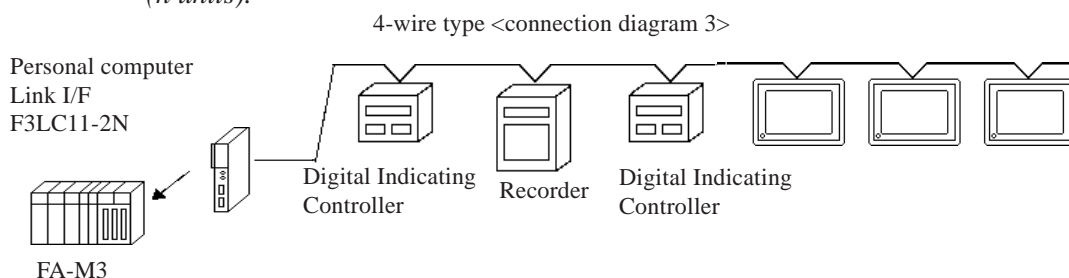

- Hereafter, equipment (i.e. a digital Indicating <UT37/38/2000> or recorder <mR series>) which supports either the FA-M3 or an identical protocol, will be called PA equipment.
- According to this PLC's design specifications, PA equipment can utilize from No. 1 through No.16 device positions, however, Nos. 17 and above cannot be used.

5.5.2 Cable Diagrams

The cable lines illustrated below and the cable lines recommended by Yokogawa Electric may differ, however, using these cables for your PLC operations will not cause any problems.

Cable Diagram 1

- When using Digital's RS-422 connector terminal adapter GP070-CN10-O

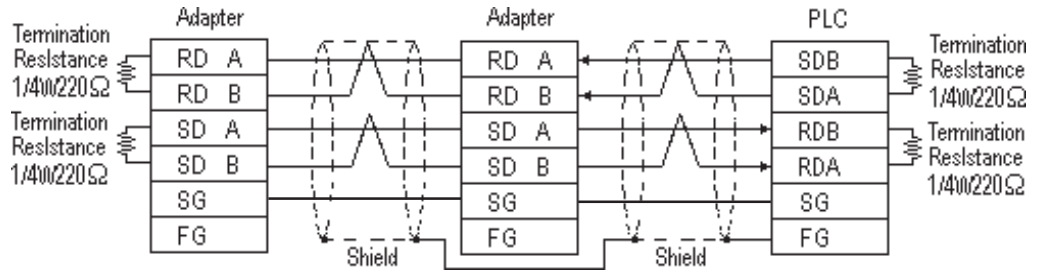

- When using Digital's Multi-link Cable, GP230-IS12-O

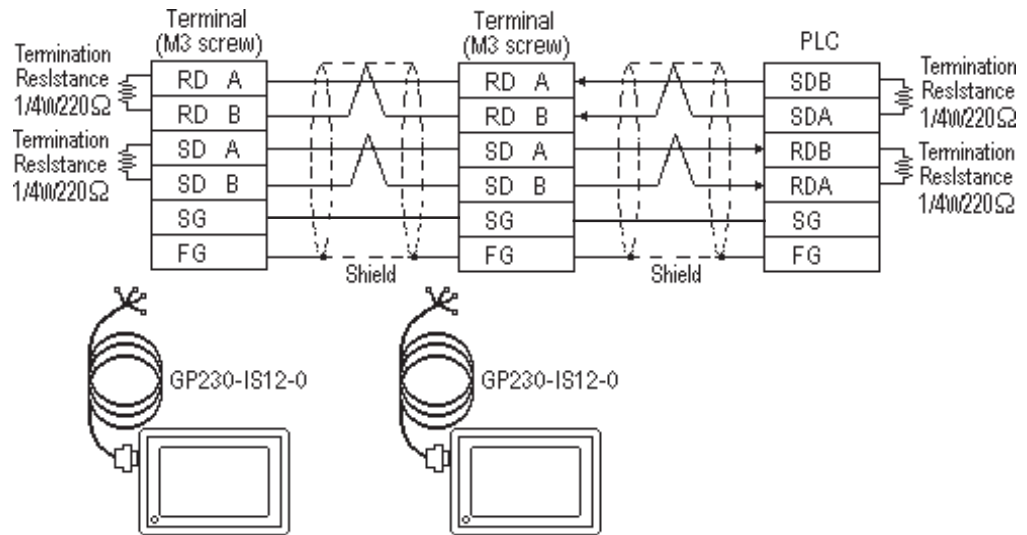

Ground your PLC's FG terminal according to your country's applicable standard. For details, refer to the corresponding PLC manual.



- **Pull out a small amount of the Transfer Cable's shield, make a wire out of it and connect it to the PLC's FG terminal.**
- **The GP230-IS12-O Cable FG terminal is not connected to the GP's FG.**
- **Connect a Termination Resistor at both ends of the cable.**
- **As a general rule, connect the PLC on one end of the circuit.**

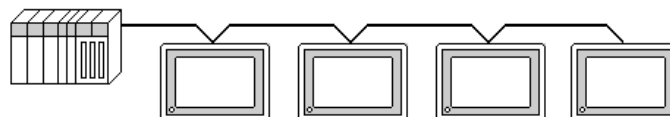



When making your own cable connections, we recommend using Hitachi Densen's CO-SPEV-SB (A) 3P* 0.5SQ.

The cable connection lines are as illustrated below. The cables between the GP and the terminals should be less than 10m.

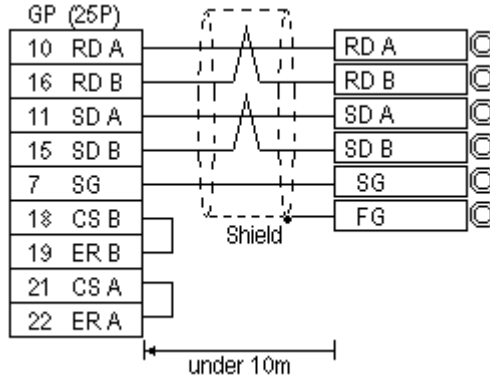

Cable Diagram 2

The following diagram is an example of the connection between the GP and PLC, showing both sides/ends of the wiring. Be sure to install terminating resistors as shown, on both side of the equipment.

- When using Digital's RS-422 connector terminal adapter GP070-CN10-O

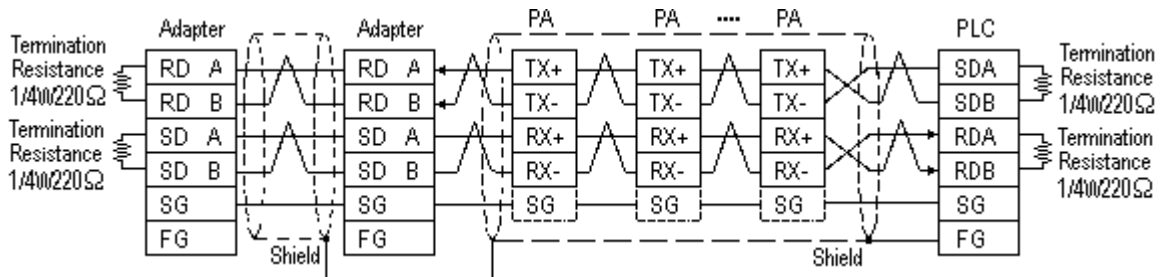

- * If a PA unit uses an SG wire, be sure to connect it.
- * If the PA unit does not have an SG wire, be sure to connect the GP's SG wire to the PLC's SG wire.

- When using Digital's Multi-link Cable, GP230-IS12-O

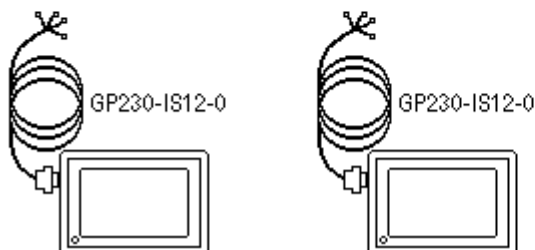
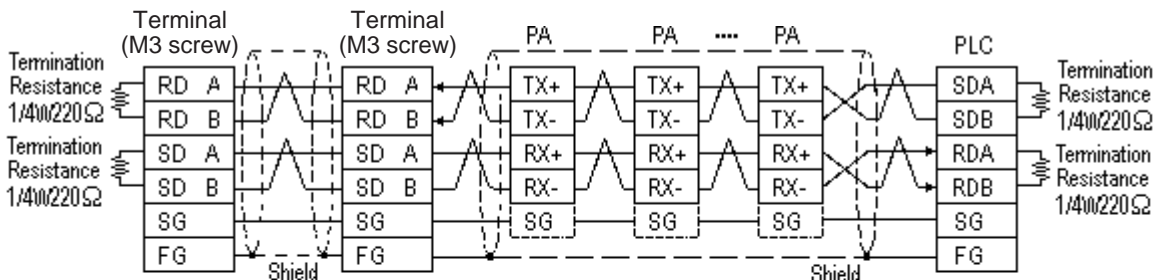

- * If a PA unit uses an SG wire, be sure to connect it.
- * If the PA unit does not have an SG wire, be sure to connect the GP's SG wire to the PLC's SG wire.



- **The naming/labeling of the A and B pins on the GP side is the reverse of the PLC side.**
- **Set up the personal computer Link I/Fs, using station(s) No. 1 to No.32.**
- **Set up unique numbers for each piece of PA equipment to be connected to the GP. If the same number is used by 2 or more pieces of PA equipment, errors will occur.**
- **Be sure that the data transmission settings between each GP (n units) and its related PA equipment (m units) are identical.**
- **Ground your PLC's FG terminal according to your country's applicable standard.**
- **Pull out a small amount of the Transfer Cable's shield, make a wire out of it and connect it to the PLC's FG terminal.**
- **The GP230-IS12-O Cable FG terminal is not connected to the GP's FG.**
- **Be aware the A and B signals of the GP and PLC are opposite to each other.**
- **Place a Termination Resistor at either end of the cable.**
- **As a general rule, connect the PLC on either end of the circuit.**



When making your own cable connections, we recommend using Hitachi Densen's CO-SPEV-SB (A) 3P* 0.5SQ.

The cable connection lines are as illustrated below. The cables between the GP and the terminals should be less than 10m.

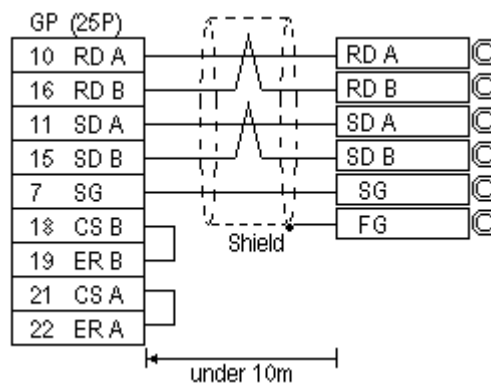

5.5.3 Supported Devices

The following describes the range of devices supported by the GP.

■ **FA-M3** (n:1 communication)

 Setup System Area or Communication Information's Storing Address here.

Device	Bit Address	Word Address	Particulars
Input Relay	X00201 ~ X71661	X00201 ~ X71649	÷16+1 *1,2
Output Relay	Y00201 ~ Y71664	Y00201 ~ Y71649	÷16+1 *1
Internal Relay	I00001 ~ I32768	I00001 ~ I32753	÷16+1
Joint Relay	E0001 ~ E4096	E0001 ~ E4081	÷16+1
Special Relay	M0001 ~ M9984	M0001 ~ M9969	÷16+1
Link Relay	L00001 ~ L78192	L00001 ~ L78177	÷16+1
Timer (contact)	T0001 ~ T3072	---	*2
Counter (contact)	C0001 ~ C3072	---	*2
Timer (current value)	---	TP0001 ~ TP3072	
Timer (setup value)	---	TS0001 ~ TS3072	*2
Counter (current value)	---	CP0001 ~ CP3072	
Counter (setup value)	---	CS0001 ~ CS3072	*2
Data Register	---	D0001 ~ D32768	Bit 5
File Register	---	B00001 ~ B65536	Bit 5 *3,4
		B065537 ~ B131072	
		B131073 ~ B196608	
		B196609 ~ B262144	
Joint Register	---	R0001 ~ R4096	Bit 5
Special Register	---	Z001 ~ Z1024	Bit 5
Link Register	---	W00001 ~ W74096	Bit 5 *5

L/H

*1 The value of the terminal number (bit), 01~49, of the last two digits for the Input Relay and

Output Relay can only be a multiple of 16 +1.

E.g. For X00201

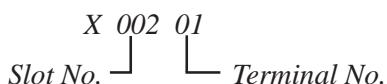

*2 Cannot perform data write.

(Continued on next page)

*3 File registers are each 65,535 words on your GP application.

You cannot extend over more than a single data "block" when performing the following features.

Be sure to set these features' settings so they are within a single data block.

- 1) "a-tag " settings
- 2) Performing Block read/write from Pro-Server
- 3) Designating the "Convert from" and "Conver to" address for the "Address Conversion" features

*4 When using a PC Link module, only Link Register up to B99999 can be used.

*5 A total of up to 4,096 link registers can be used.



- Write the CPU Number (1~4) in front of the device name.

E.g. For Internal Relay I0001, CPU #3:

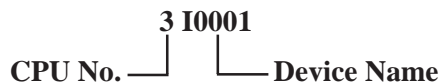

- The range of device that can be used will vary depending on the type of PLC. For detailed information refer to the Yokogawa's Sequence CPU manual.

■ FA-M3 (n:m communication)

Setup System Area or Communication Information's Storing Address here.

Device	Bit Address	Word Address	Particulars
Input Relay	X00201 ~ X71364	X00201 ~ X71349	÷16+1 *1,2
Output Relay	Y00201 ~ Y71364	Y00201 ~ Y71349	÷16+1 *1
Internal Relay	I0001 ~ I16384	I0001 ~ I16369	÷16+1
Joint Relay	E0001 ~ E4096	E0001 ~ E4081	÷16+1
Special Relay	M0001 ~ M9984	M0001 ~ M9969	÷16+1
Link Relay	L00001 ~ L71024	L00001 ~ L71009	÷16+1
Timer (contact)	T0001 ~ T2047	---	*2
Counter (contact)	C0001 ~ C2047	---	*2
Timer (current value)	---	TP0001 ~ TP2047	L/H
Timer (setup value)	---	TS0001 ~ TS2047	*2
Counter (current value)	---	CP0001 ~ CP2047	
Counter (setup value)	---	CS0001 ~ CS2047	*2
Data Register	---	D0001 ~ D2047	Bit 1 5
File Register	---	B0001 ~ B2047	Bit 1 5
Joint Register	---	R0001 ~ R2047	Bit 1 5
Special Register	---	Z001 ~ Z1024	Bit 1 5
Link Register	---	W00001 ~ W11023	Bit 1 5 *3

(Continued on next page)

*1 The value of the terminal number (bit), 01~49, of the last two digits for the Input Relay and Output Relay can only be a multiple of 16 +1.

E.g. For X00201

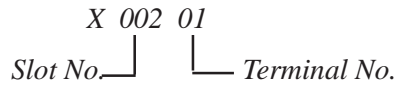

*2 Cannot perform data write.

*3 A total of up to 4,096 link registers can be used.



- Write the CPU Number (1~4) in front of the device name.

E.g. For Internal Relay I0001, CPU #3:



The range of device that can be used will vary depending on the type of PLC. For detailed information refer to the Yokogawa's Sequence CPU manual.

- When setting tags up in GP-PRO/PBIII for Windows, the PLC Station number can be specified during address Input. If a station number is not designated, it automatically uses the previously entered station number. (The initial default value is 1.)

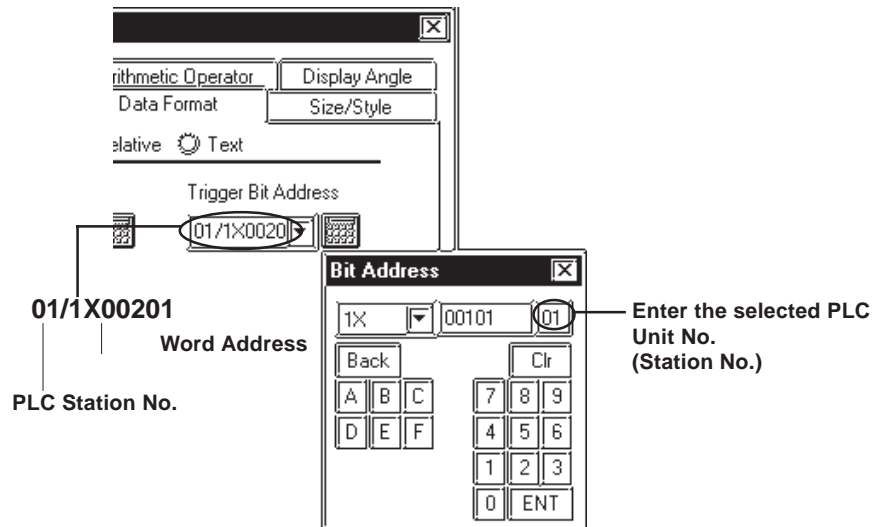

5.5.4 Environment Setup

The following lists Digital's recommended PLC and GP communication settings.

■ FACTORY ACE Series

GP Setup		Link I/F Setup	
Baud Rate	19200 bps	Baud Rate	19200 bps
Data Length	8 bits	Data Bit	8 bits
Stop Bit	1 bit	Stop Bit	1 bit
Parity Bit	None	Parity Bit	None
Data Flow Control	ER Control	---	
Communication Format	4-wire type	---	
---		Check Sum	No
---		Specify End Character	Yes
---		Protect Function	No
---		Data Format Setup Switch	8 OFF
Unit No.	1	Station Number	1
Unit. No. (n:m Comm)	Match so all GP, PC Link Unit station no.s are the same.	Station No. (n:m Comm)	Setup so all PA Equip., PC Link Unit no.'s are different.



5.6 Toshiba

5.6.1 System Structure

The following describes the system structure for connecting the GP to Toshiba PLCs.

Reference The Cable Diagrams mentioned in the following tables are listed in the section titled "5.6.2 Cable Diagrams".

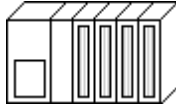
PROSEC T Series (using CPU unit Link I/F)

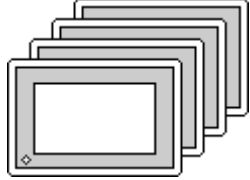
CPU	Cable Diagram	GP
		
T3 (Version 1.8+) ^{†1}	(Cable Diagram 1)	GP Series

*1 Connect to the CPU Module's computer link port.

5.6.2 Cable Diagrams

The cable diagrams illustrated below and the cable diagrams recommended by Toshiba may differ, however, using these cables for your PLC operations will not cause any problems.

Cable Diagram 1

- When using Digital's RS-422 connector terminal adapter, GP070-CN10-O

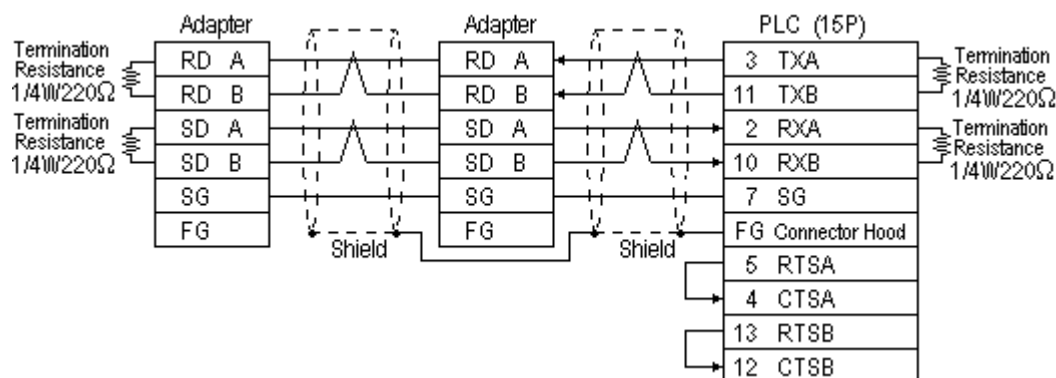

- When using Digital's Multi-link Cable, GP230-IS12-O

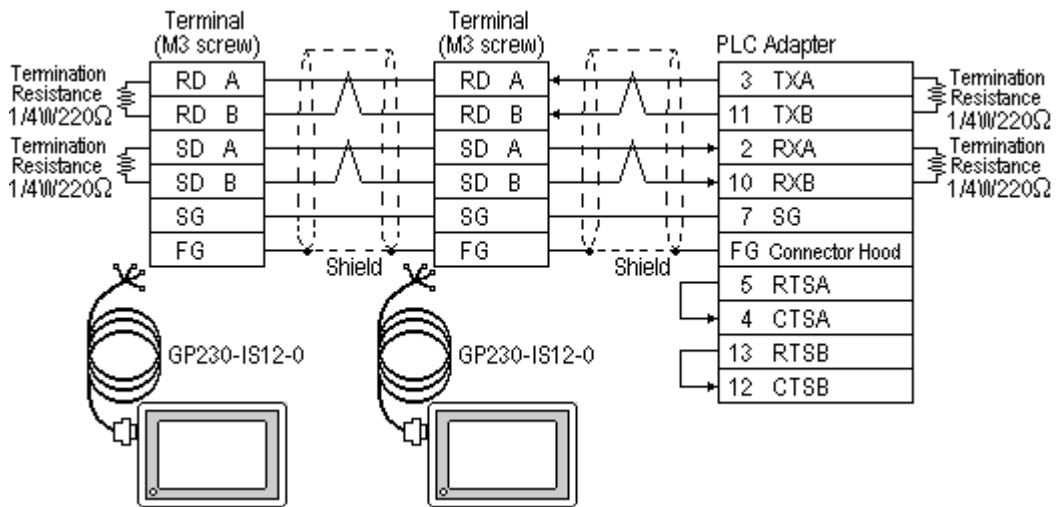

Ground your PLC's FG terminal according to your country's applicable standard. For details, refer to the corresponding PLC manual.



- Pull out a small amount of the Transfer Cable's shield, make a wire out of it and connect it to the PLC's FG terminal.
- The GP230-IS12-O Cable FG terminal is not connected to the GP's FG.
- Attach a Termination Resistor at both ends of the cable.
- For the RS-422 connection, refer to Toshiba's PLC manual for the cable length.
- As a general rule, connect the PLC at the end of the circuit.

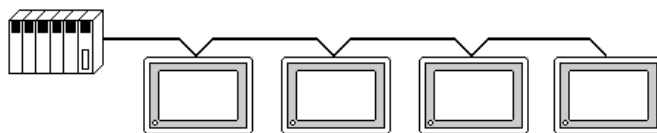

When making your own cable, Hitachi Densen's CO-SPEV-SB-(A) 3P*0.5 cable is recommended as the connection cable.

The cable connection lines are as illustrated below. The cables between the GP and the terminals should be less than 10m.

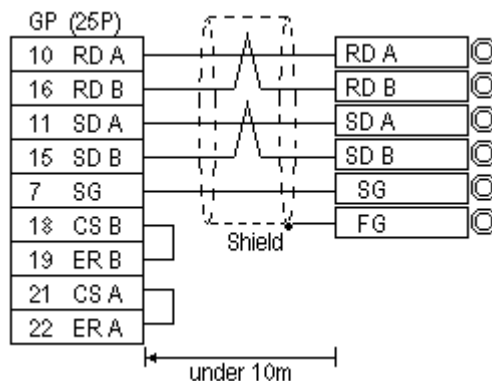

5.6.3 Supported Devices

The following describes the range of devices supported by the GP.

PROSEC T Series

 Setup System Area or Communication Information's Storing Address here.

Device	Bit Address	Word Address	Particulars
External Input	X00000 ~ X255F	XW0000 ~ XW255	L/H
External Output	Y00000 ~ Y255F	YW0000 ~ YW255	
Internal Relay	R00000 ~ R511F	RW0000 ~ RW511	
Special Relay	S0000 ~ S255F	SW000 ~ SW255	
Link Register Relay	Z0000 ~ Z511F	---	
Link Relay	L0000 ~ L255F	---	
Timer (contact)	T000 ~ T255	---	
Counter (contact)	C000 ~ C255	---	
Timer (current value)	---	T000 ~ T511	
Counter (current value)	---	C000 ~ C511	
Data Register	---	 D0000 ~ D8191	
Link Register	---	W0000 ~ W1023	
File Register	---	F0000 ~ F8191	

5.6.4 Environment Setup

The following lists Digital's recommended PLC and GP communication settings.

PROSEC T Series

GP Setup		CPU Module Setup	
Baud Rate	19200 bps *1	Baud Rate	19200 bps *1
Data Length	8 bits	Data Bit	8 bits
Stop Bit	2 bits	Stop Bit	2 bits
Parity Bit	Odd	Parity Bit	Odd
Data Flow Control	ER Control		---
Communication Format	4-wire type		---
Unit No.	1	Station Number	1

* 1 According to this PLC's specifications, if the PROSEC T3 is Ver. 1.4 or lower, data transmission is possible only at 9600 bps or less .





5.7 Rockwell (Allen-Bradley)

5.7.1 System Structure

The following describes the system structure for connecting the GP to Rockwell (Allen-Bradley) PLCs.

Reference The Cable Diagrams mentioned in the following tables are listed in the section titled "5.7.2 Cable Diagrams".

■ AB SLC 500 Series (using CPU unit Link I/F)

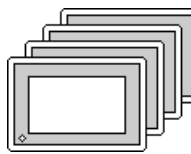
CPU	Cable Diagram	GP
		
SLC-5/03 SLC-5/04	(Cable Diagram 1) ^{*1}	GP Series

* 1 An RS-232C/422 converter is required. (Refer to the diagram below.) Use an RS-232C/422 converter with the terminal block on the RS-422 side, and which uses a power supply other than that used by the communication line.

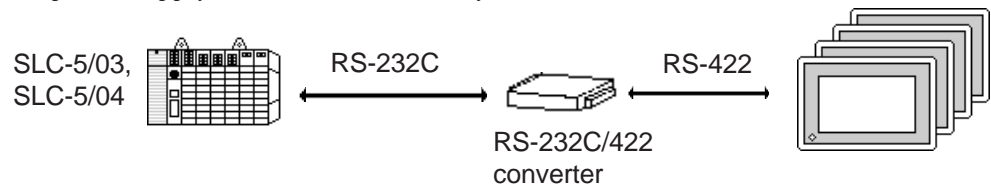

5.7.2 Cable Diagrams

Although some wiring diagrams recommended by Rockwell (Allen-Bradley) may differ from the wiring diagrams illustrated below, please use the diagrams shown in this manual.

Cable Diagram 1

- When using Digital's RS-422 connector terminal adapter GP070-CN10-O

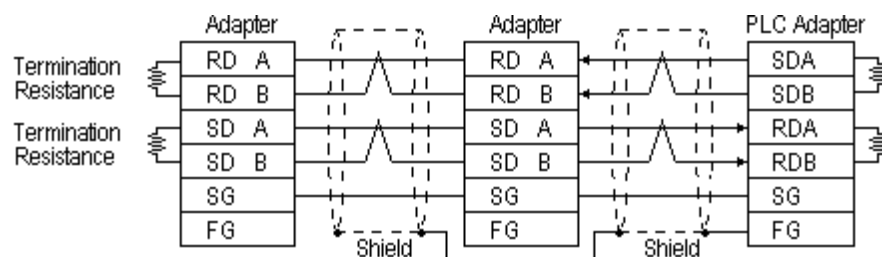

* Check the PLC Adapter specifications for the Termination Resistance

- When using Digital's Multi-link Cable, GP230-IS12-O

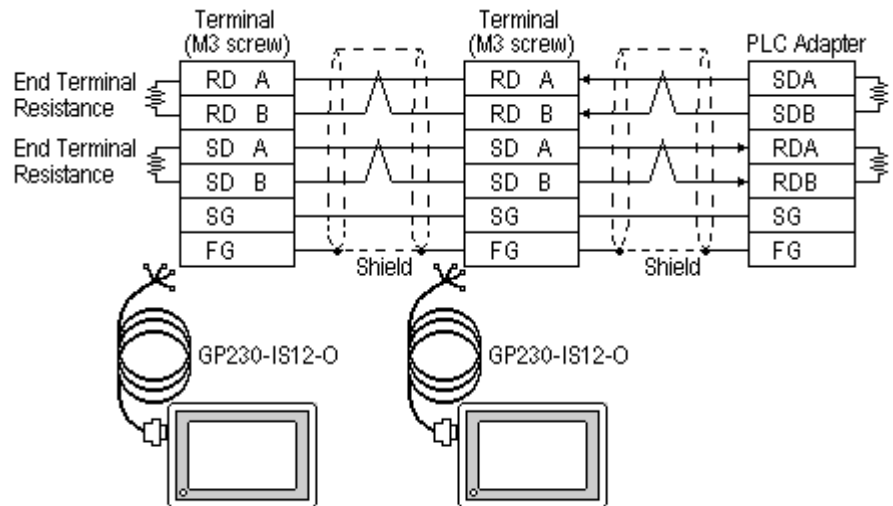

* Check the PLC Adapter specifications for the End Terminal Resistance



Ground your PLC's FG terminal according to your country's applicable standard. For details, refer to the corresponding PLC manual.



- Pull out a small amount of the Transfer Cable's shield, make a wire out of it and connect it to the PLC's FG terminal.
- The GP230-IS12-O Cable FG terminal is not connected to the GP's FG.
- Attach a Termination Resistor at both ends of the cable.
- For the RS-422 connection, refer to Rockwell's PLC manual for the cable length.
- As a general rule, connect the PLC to one end of the circuit.

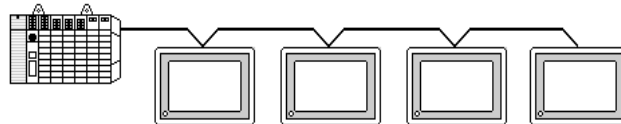

When making your own connections, Hitachi Densen's CO-SPEV-SB(A)3P*0.5 cable is recommended.

The cable connection lines are as illustrated below. The cables between the GP and the terminals should be less than 10m.

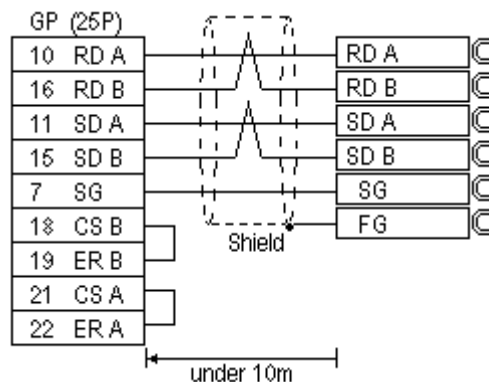

5.7.3 Supported Devices

The following describes the range of devices supported by the GP.

■ AB SLC 500 Series

 Setup System Area or Communication Information's Storing Address here.

Device	Bit Address	Word Address	Particulars	
Bit	B0030000 ~ B003255F B0100000 ~ B255255F	B003000 ~ B003255 B010000 ~ B255255		H/L
Timer (TT: Timing Bit)	TT0040000 ~ TT0042550 TT0100000 ~ TT2552550	---	*1	L/H
Timer (DN: Completion Bit)	TN0040000 ~ TN0042550 TN0100000 ~ TN2552550	---	*1	
Timer (PRE: Setup Value)	---	TP004000 ~ TP004255 TP010000 ~ TP255255	*2	
Timer (ACC: Current Value)	---	TA004000 ~ TA004255 TA010000 ~ TA255255	*2	
Counter (CU: Up Count)	CU0050000 ~ CU0052550 CU0100000 ~ CU2552550	---	*1	
Counter (DC: Down Count)	CD0050000 ~ CD0052550 CD0100000 ~ CD2552550	---	*1	
Counter (CN: Completion Bit)	CN0050000 ~ CN0052550 CN0100000 ~ CN2552550	---	*1	
Counter (PRE: Setup Value)	---	CP005000 ~ CP005255 CP010000 ~ CP255255	*2	
Counter (ACC: Current Value)	---	CA005000 ~ CA005255 CA010000 ~ CA255255	*2	
Integral Number	---	N007000 ~ N007255 N010000 ~ N255255		

* 1As in Example 4 in the following Caution section, enter a 0 at the end. For further information, refer to the manual for your PLC.

* 2When reading and writing consecutive addresses at least two words long, reading will take longer than for other devices, and the screen refresh will be slower.



- File Numbers 0~7 are the User's default files.
- If a device is specified that was not previously allocated in the PLC data table map, a host communication error (02:10), (02:D7), or (02:E1) will be displayed.

5.7.4 Environment Setup

The following lists Digital's recommended PLC and GP communication settings.

■ AB SLC 500 Series

GP Setup		PLC Setup	
Baud Rate	19200 bps	Baud Rate	19200 bps
Data Length	8 bits		---
Stop Bit	1 bit		---
Parity Bit	Even	Parity Bit	EVEN
Data Flow Control	ER Control		---
Communication Format	4 wire type		---
	---	Communication Driver	DF1 HALF-DUPLEX SLAVE ^{*1}
	---	Duplicate Packet Detection	DISABLE ^{*1}
	---	Error Detection	BCC ^{*1}
	---	Control Line	No Handshaking ^{*1}
Unit No. (DH GP) ^{*2}	0	Station Address ^{*2}	0

**1 Will not operate without these settings.*

**2 Setup the Station Address and the GP's Unit No. (DH GP) address to the same value (address set as decimal values). It is unnecessary to setup the DH PLC address.*





5.8 Keyence

5.8.1 System Structure

The following describes the system structure for connecting the GP to Keyence PLCs.

Reference The Cable Diagrams mentioned in the following tables are listed in the section titled "5.8.2 Cable Diagrams".

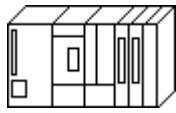
■ KZ-300/KZ-350 Series (using Link I/F)

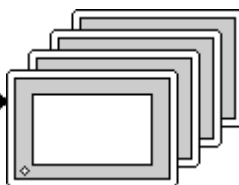
CPU	Link I/F	Cable Diagram	GP
	PC Link Unit 		
KZ-300 KZ-350	KZ-L2 *1	(Cable Diagram 1)	GP Series

*1 Connect to Port 2.

5.8.2 Cable Diagrams

The cable lines illustrated below and the cable lines recommended by Keyence may differ; however, using these cables for your PLC operations will not cause any problems.

Cable Diagram 1

- When using Digital's RS-422 connector terminal adapter, GP070-CN10-O

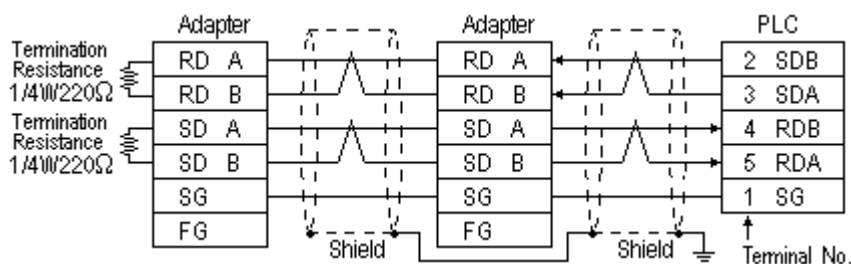

- When using Digital's Multi-link Cable, GP230-IS12-O

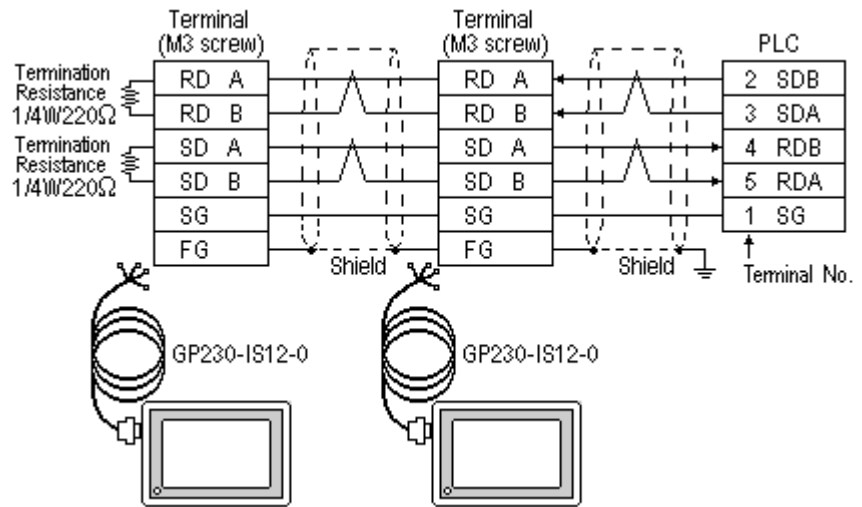

Ground your PLC's FG terminal according to your country's applicable standard. For details, refer to the corresponding PLC manual.



- **The GP230-IS12-O Cable FG terminal is not connected to the GP's FG.**
- **Note that the naming/labeling of the A and B pins on the GP side is the reverse of the PLC side.**
- **Attach a Termination Resistor to both ends of the cable.**
- **For the RS-422 connection, refer to Keyence's PLC manual for the cable length.**
- **As a general rule, connect the PLC to one end of the circuit.**

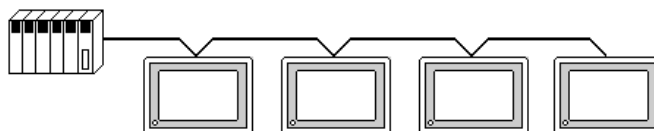



When making your own cable, Hirakawa's H-9293A (CO-HC-ESV-3P*7/0.2) cable is recommended.

The cable connection lines are as illustrated below. The cables between the GP and the terminals should be less than 10m.

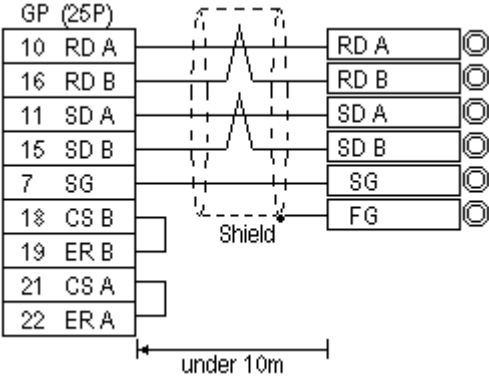



5.8.3 Supported Devices

The following describes the range of devices supported by the GP.

■ KZ-300/KZ-350 Series

 Setup System Area or Communication Information's Storing Address here.

Device	Bit Address	Word Address	Particulars
Input Relay	0000 - 0009	00 - 00	L/H
	7000 - 17415	70 - 174	
Output Relay	0500 - 0503	05 - 05	
	7500 - 17915	75 - 179	
Auxiliary Relay	0504 - 0915	---	
Internal Relay	1000 - 6915	10 - 69	
Special Relay	2000 - 2915	20 - 29	
Timer (contact)	T000 - T249	---	
Counter (contact)	C000 - C249	---	
Timer (current value)		T000 - T249	
Counter (current value)		C000 - C249	
Data Memory		DM0000 - DM9999	
Temp. Data Memory		TM00 - TM31	

* 1 Address numbers *000~*400 are available for bit device addresses, and *0~*4 are available for word device addresses.

Bit Address	Word Address
addr 7000	70
addr 7100-7400	71-74
addr 8000	80
addr 8100-8400	81-84
addr 17000-17400	170-174

* 2 Address numbers *500~*900 are available for bit device addresses and *5~*9 are available for word device addresses.

Bit Address	Word Address
addr 7500	75
addr 7600-7900	76-79
addr 8500	85
addr 8600-8900	86-89
addr 17500-17900	175-179

5.8.4 Environment Setup

The following lists Digital's recommended PLC and GP communication settings.

■ KZ-300/KZ-350 Series

GP Setup		PC Link Unit Setup	
Baud Rate	19200 bps	Baud Rate	19200 bps
Data Length	7 bits	Data Bit	7 bits
Stop Bit	2 bits	Stop Bit	2 bits
Parity Bit	Even	Parity Bit	Even
Data Flow Control	ER Control	---	
Communication Format	4-wire type	Port Toggle Switch	RS-422A
---		RUN Mode	Link Mode
Unit No.	0	Station Number	0





5.9 Yaskawa Electric

5.9.1 System Structure

The following describes the system structure for connecting the GP to Yaskawa Electric PLCs.

Reference The Cable Diagrams mentioned in the following tables are listed in the section titled "5.9.2 Cable Diagrams".

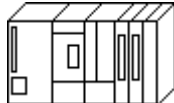
■ Memocon-sc Series/GL 120, 130 (using Link I/F)

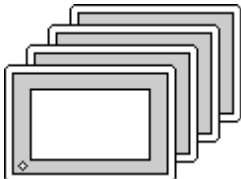
CPU	Link I/F	Cable Diagram	GP
	Link Unit 		
GL120 GL130	JAMSC-120NOM27100	RS-422 (Cable Diagram 1)	GP Series

5.9.2 Cable Diagrams

The cable diagrams illustrated below and the cable diagrams recommended by Yaskawa Electric may differ, however, using these cables for your PLC operations will not cause any problems.

Cable Diagram 1

- When using Digital's RS-422 connector terminal adapter, GP070-CN10-O.

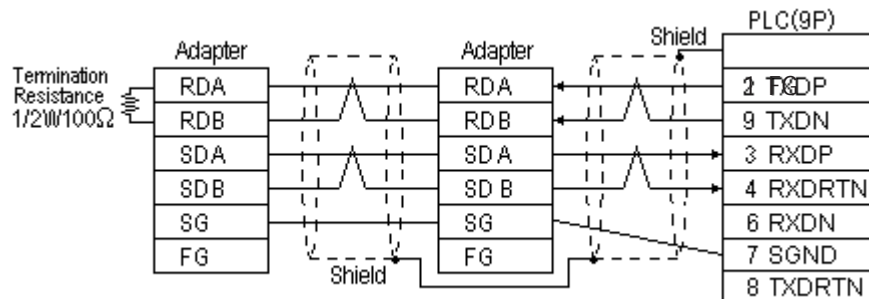

- When using Digital's Multi-link Cable, GP230-IS12-0

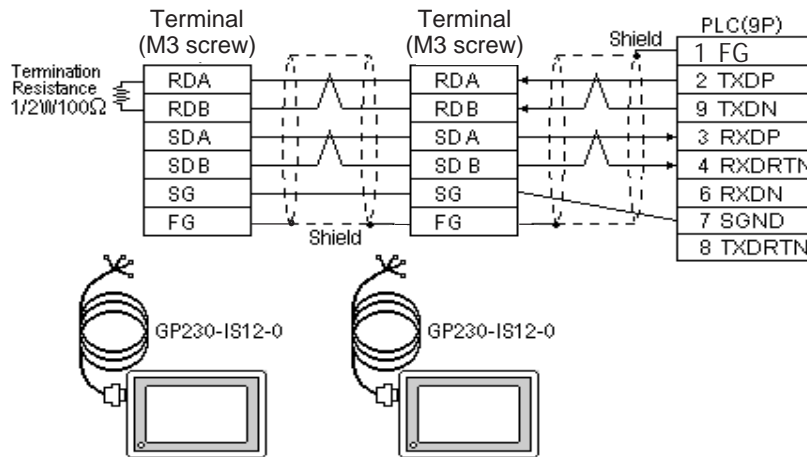

Ground your PLC's FG terminal according to your country's applicable standard. For details, refer to the corresponding PLC manual.



- Pull out a small amount of the Transfer Cable's shield, make a wire out of it and connect it to the PLC's FG terminal.
- The GP230-IS12-0 Cable FG terminal is not connected to the GP's FG.
- Attach a Termination Resistor to both ends of the cable.
- For the RS-422 connection, refer to Yaskawa Electric's PLC manual for the cable length.
- As a general rule, connect the PLC to one end of the circuit.

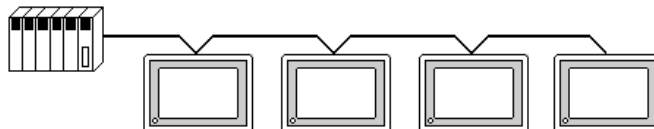

When making your own cable, Hitachi's CO-SPEV-SB (A) 3P*0.5 cable is recommended.

The cable connection lines are as illustrated below. The cables between the GP and the terminals should be less than 10m.

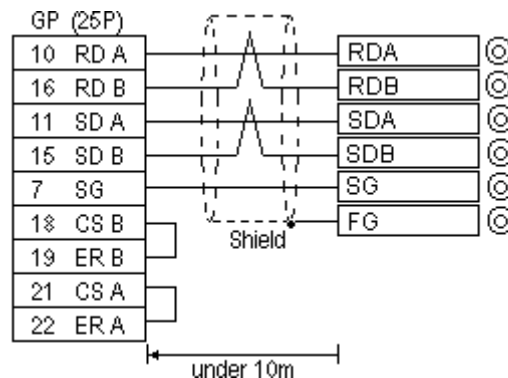







5.9.3 Supported Devices

The following describes the range of devices supported by the GP.

■ Memocon-sc series (GL120 and GL130)

 Setup System Area or Communication Information's Storing Address here.

Device	Bit Address	Word Address	Particulars
Coil (output/internal)	000001 ~ 008192	---	*1
Input Relay	100001 ~ 101024	---	*1*2
Link Coil 1	D10001 ~ D11024	---	*1
Link Coil 2	D20001 ~ D21024	---	*1
MC Relay 1	X10001 ~ X10256	---	*1*2
MC Relay 2	X20001 ~ X20256	---	*1*2
MC Coil 1	Y10001 ~ Y10256	---	*1
MC Coil 2	Y20001 ~ Y20256	---	*1
MC Code Relay 1	M10001 ~ M10096	---	*1*2
MC Code Relay 2	M20001 ~ M20096	---	*1*2
MC Control Relay 1	P10001 ~ P10256	---	*1*2
MC Control Relay 2	P20001 ~ P20256	---	*1*2
MC Control Coil 1	Q10001 ~ Q10256	---	*1
MC Control Coil 2	Q20001 ~ Q20256	---	*1
Input Register	---	300001 ~ 300512	 *2
Output Register	---	300001 ~ 300512	
Holding Register	---	400001 ~ 409999	
Link Register 1	---	R10001 ~ R11024	
Link Register 2	---	R20001 ~ R21024	
Constant Register	---	700001 ~ 704096	

H/L

* 1 1-word (16-bit) data day be specified.

* 2 Data cannot be written here.

5.9.4 Environment Setup

The following lists Digital's recommended PLC and GP communication settings.

■ Memocon-sc series (GL 120 and GL 130)

GP Setup		PC Link Unit Setup	
Baud Rate	19200 bps	Baud Rate	19200 bps
Data Length	8 bits	---	
Stop Bit	1 bit	Stop Bit	1 bit
Parity Bit	Even	Parity Bit ON/OFF EVEN/ODD	ON Even
Data Flow Control	ER Control	---	
Communication Format	4-wire type	Communication Format	RS-422
Unit No.	1	Slave address number	1
---		Transmission bit	RTU mode (fixed)



5.10 SHARP

5.10.1 System Structure

The following describes the system structure for connecting the GP to Sharp PLCs.

Reference The Cable Diagrams mentioned in the following tables are listed in the section titled "5.10.2 Cable Diagrams".

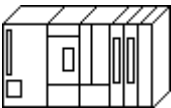
■ New Satellite JW

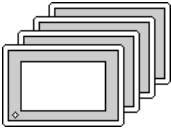
CPU	Link I/F	Cable Diagram	GP
			
JW-33CUH3	Link I/F on CPU unit	RS-422 (4 wires) (Connected to PG/COM 1 port or PG/COM 2 port) (Cable Diagram 1)	GP Series
	JW-21CM	RS-422 (4 wires) (Cable Diagram 2)	



When using JW-21CM, be aware that some link units have usage restrictions depending on the ROM version.

Version Seal	Usage Restrictions
30Hn	Can use without restrictions.
30H	Cannot be read or written from and to File Register from 10 to 2C. Cannot be read or written from and to File Register Address from 100000 to 176777.
No Seal	Cannot use JW30H series.

5.10.2 Cable Diagrams

The cable diagrams illustrated below and the cable diagrams recommended by Yaskawa Electric may differ, however, using these cables for your PLC operations will not cause any problems.

Cable Diagram 1

- When using Digital's RS-422 connector terminal adapter, GP070-CN10-O

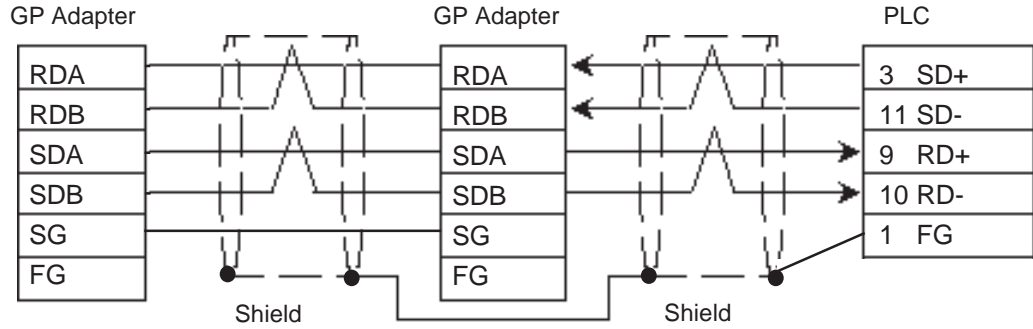

- When using Digital's Multi-link Cable, GP230-IS12-O

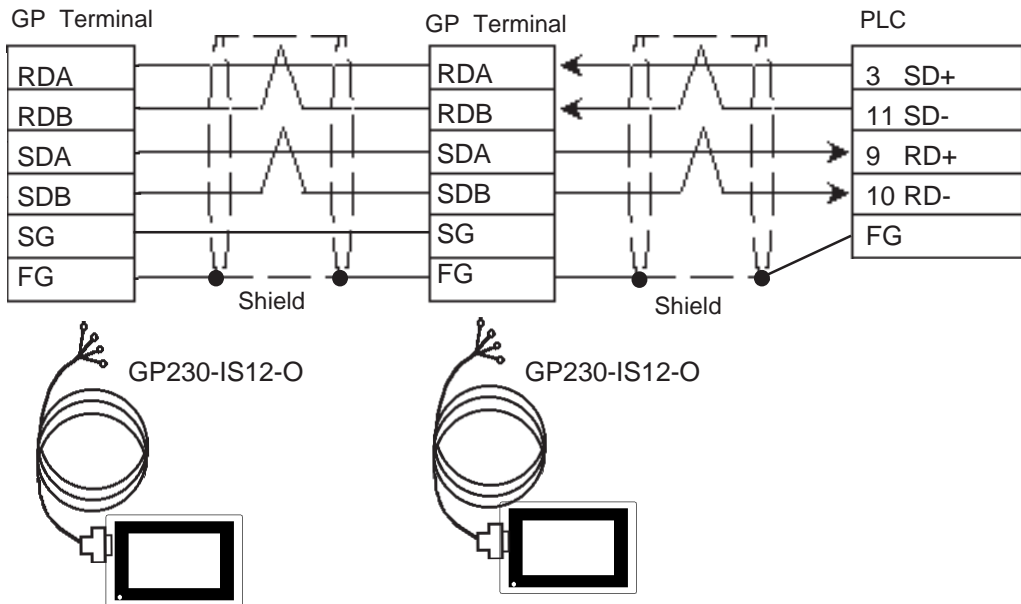

Ground your PLC's FG terminal according to your country's applicable standard. For details, refer to the corresponding PLC manual.



- **Pull out a small amount of the Transfer Cable's shield, make a wire out of it and connect it to the PLC's FG terminal.**
- **The GP230-IS12-O Cable FG terminal is not connected to the GP's FG.**
- **Attach a Termination Resistor to both ends of the cable.**
- **As a general rule, connect the PLC to one end of the circuit.**



Note: When making your own cable, Hitachi's CO-SPEV -SB(A) 3P0.5mm² cable is recommended as the connection cable.
 The cable connection lines are as shown below. The cables between the GP and the terminals should be less than 10m.

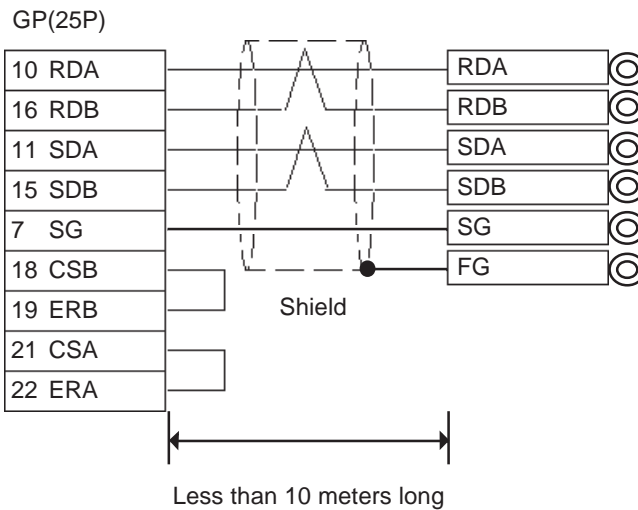
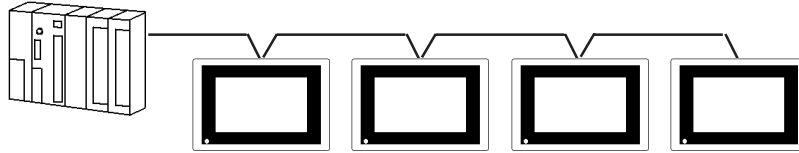

Cable Diagram 2

- When using Digital's RS-422 connector terminal adapter, GP070-CN10-O

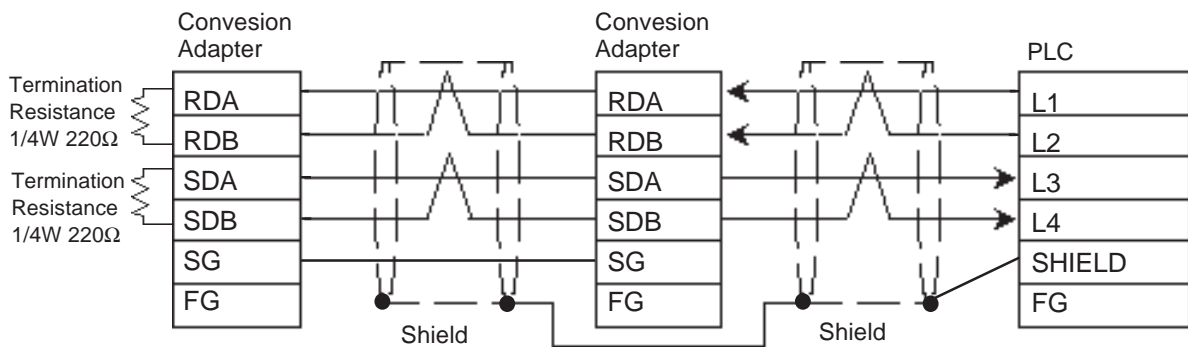

- When using Digital's Multi-link Cable, GP230-IS12-O

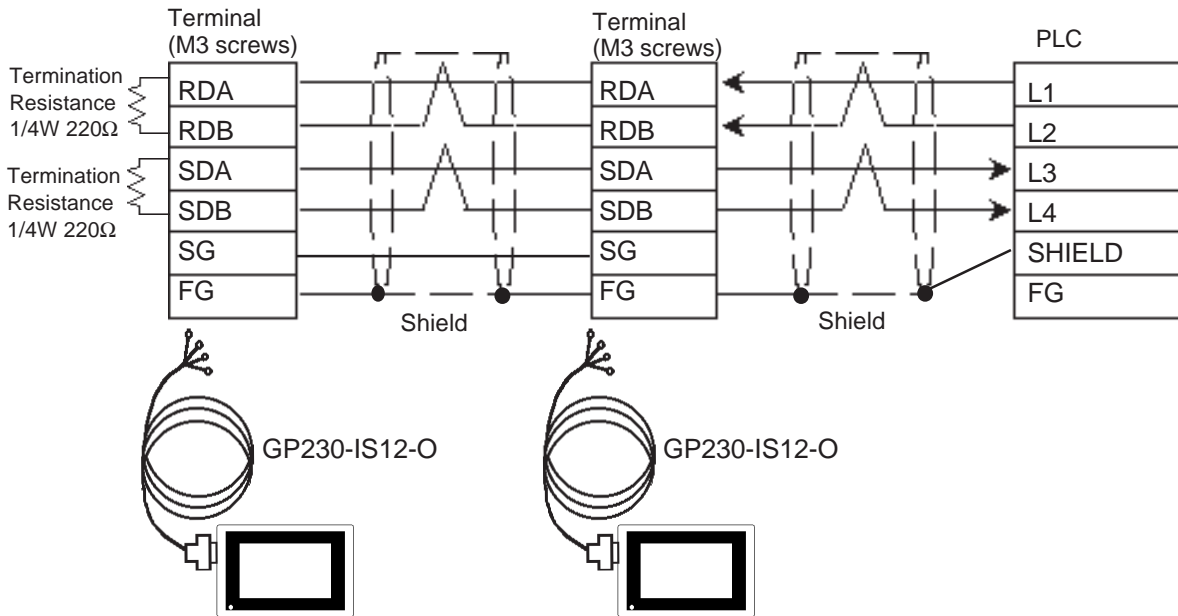

Note:

- When making your own cable, Hitachi's CO-SPEV -SB(A) 3P0.5mm² cable is recommended as the connection cable. The cable connection lines are as shown below. The cables between the GP and the terminals should be less than 10m.
- Use a cable length less than 600m.

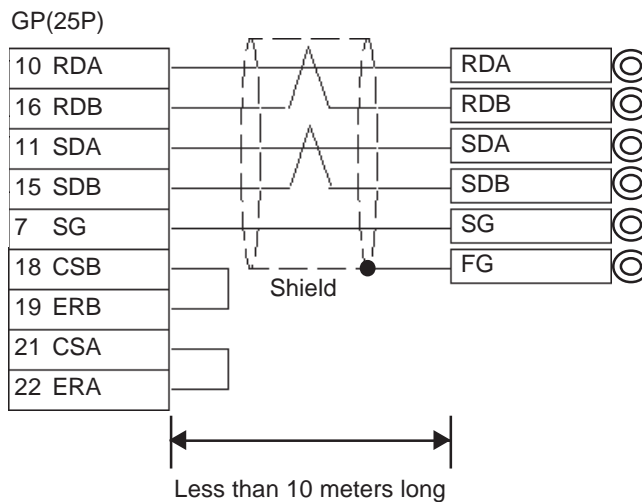
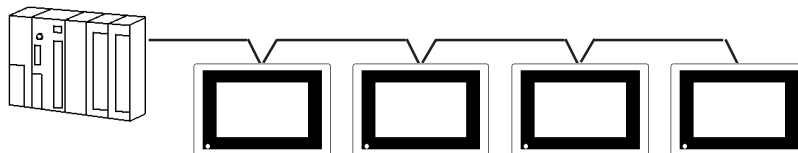

5.10.3 Supported Devices

The following lists Digital's recommended PLC and GP communication settings.

■ New Satellite JW (JW-33CUH3)

 Setup System Area or Communication Information's Storing Address here.

Device	Bit Address	Word Address	Particulars
Relay	00000 ~ 15777	A0000 ~ A1576 (≡0000 ~ ≡1576)	÷ 2
	20000 ~ 75777	A2000 ~ A7576 (≡2000 ~ ≡7576)	
Timer (contact)	T0000 ~ T1777	—	
Counter (contact)	C0000 ~ C1777	—	
Timer/Counter (current value)	—	B0000 ~ B3776 (b0000 ~ b3776)	÷ 2 Bit 15
Register	—	09000 ~ 09776	÷ 2 Bit 15
		19000 ~ 19776	
		29000 ~ 29776	
		39000 ~ 39776	
		49000 ~ 49776	
		59000 ~ 59776	
		69000 ~ 69776	
		79000 ~ 79776	
		89000 ~ 89776	
		99000 ~ 99776	
		E0000 ~ E0776	
		E1000 ~ E1776	
		E2000 ~ E2776	
		E3000 ~ E3776	
		E4000 ~ E4776	
		E5000 ~ E5776	
		E6000 ~ E6776	
E7000 ~ E7776			
File Register 1	—	1000000 ~ 1037776	÷ 2 Bit 15 *1
File Register 2		2000000 ~ 2177776	
File Register 3		3000000 ~ 3037776	
File Register 10-1F		F1000000 ~ F1F17776	
File Register 20-2C		F2000000 ~ F2C17776	

L/H

* 1 File Registers consist of a File number and an Address.

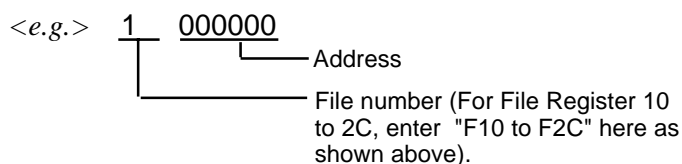

 **2** Enter even numbers only for Word Address

 **15** You can select a bit. input a bit position after Word Address. The value of a bit position must be between 0 to 15.



Word Address Relay and Timer/Counter current value (B) are shown in brackets on the PLC's Uesrs manual, however, you must enter " A**** ", " B**** " when you are entering the value in the GP-PRO/PB III software.

5.10.4 Environment Setup

The following shows Digital's recommended PLC settings and GP settings.

■ New Satellite JW Series (Using JW-21CM)

GP Setup		Link Unit Setup *3	
Baud Rate	19200 bps	Baud Rate	19200bps
Data Length	7 bits (fixed)	Data bit	7 bits (fixed)
Stop Bit	2 bit (fixed)	Stop Bit	2 bit (fixed)
Parity Bit	Even	Parity Bit	Even
Data Flow Control	ER Control	-----	
Communicaiton Format	4-wire type	Communicaiton Mode	4-wire type
-----		Function Setting Switch (SO)	Computer Link
Unit No. *1	1 (1 to 31)	Station Address *2	1(1 to 37)

■ New Satellite JW Series (Using Link I/F on CPU unit)

GP Setup		Link Unit Setup *3	
Baud Rate *4	19200 bps	Baud Rate	19200 bps
Data Length	7 bits (fixed)	Data bit	7 bits (fixed)
Stop Bit	2 bit (fixed)	Stop Bit	2 bit (fixed)
Parity Bit	Even	Parity Bit	Even
Data Flow Control	ER Control	-----	
Communication Format	4-wire type	Communication Mode	4-wire type
Unit No. *1	1(1 to 31)	Station Address *2	1(1 to 37)

< PLC Settings >

Please set up the PLC system memory (#***) as shown below. For these settings, only PRO-Control or the Ladder Programming software can be used. The PLC system memory cannot be accessed by GP.

PLC System Memory No.	Details	
#234	Baud Rate, Parity, Stop bit	Communication 1
#235	Station No. 001 ~ 037oct	(PG/COM1 port)settings
#236	Baud Rate, Parity, Stop bit	Communication 2
#237	Station No. 001 ~ 037oct	(PG/COM2 port)settings

*1 This value must be in decimal.

*2 This value must be in octal.

*3 For PLC settings, use the link unit's switch. For details, please refer to Sharp's JW-21CM users manual.

*4 When Using Link I/F on CPU unit, the baud rate 115.2k bps can also be used.

6 Special Connection

6.1 Connectable PLCs

The following table lists the PLCs that can be connected and used with the GP via a special connection.

Co.	Series Name	CPU	Link I/F	Comments	Screen Editor PLC setup
R O C K W E L L (A L L E N . B R A D L E Y)	SLC 500	SLC-5/01	DH485 Port on CPU	It is possible to directly connect the PLC having DH485 port.	AB SLC500 DH485
		SLC-5/02			
	SLC-5/03	1747-AIC Link coupler (Allen-Bradley's)	Connection to the DH485 network can be made by using the linkcoupler shown at left.		
	SLC-5/04				
		SLC-5/04	DH Plus port on CPU		AB Data Highway Plus
	PLC5	PLC5/20	DH Plus port on CPU		AB Data Highway Plus
		PLC5	REMOTE I/O Channel on CPU		AB Remote IO
M O D I C O N	Modbus Master				Modicon Modbus (SLAVE)
	884/984	884, 984A, 984B	Modbus Plus Port on CPU		Modicon Modbus Plus



6.2 Rockwell (Allen-Bradley)

6.2.1 System Structure

■ AB SLC 500 Series (Using DH485)

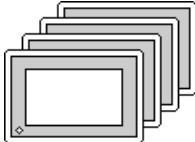
CPU	Unit	Cable Diagram	GP
	←————→		
SLC-5/01 SLC-5/02 SLC-5/03 SLC-5/04	1747-PIC Link coupler (Allen Bradley's)	HMI-CAB-C83 ^{*1} (TCP's) ^{*2} HMI-CAB-C84 ^{*1} (TCP's) ^{*2}	GP Series

*1 Use the HMI CAB-C83 cable at 1:1, or HMI CAB-C84 at m:n.

*2 Manufactured by Total Control Products, Inc.

■ AB SLC 500 Series (Using Data Highway Plus)

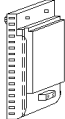



CPU	Cable Diagram	Unit	GP
	←————→		 DH Plus Module
SLC-5/04	(Cable Diagram 1)	QPI-CAB-C201 (TCP's) ^{*1}	Large Size GPs ^{*2}
		QPJ-CAB-C201 (TCP's) ^{*1}	Medium Size GPs ^{*3}

*1 Manufactured by Total Control Products, Inc.

*2 When using the GP-470E, GP-570T, GP570T, GP-570S, GP-57JS, GP-570VM, GP-571T, GP-477RE, GP-577RT, GP-577RS, GP675T, GP-675S, GP-870VM, GP-2500T, GP-2600T. For GP2000 Series, however, a bus conversion unit (PSL-CONV00) is required.

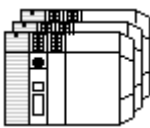
*3 When using the GP270L, GP270S, GP370L, GP370S, GP377RT

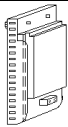
■ **AB PLC-5 Series (Using Data Highway Plus)**



CPU	Cable Diagram	Unit	GP
		 DH Plus Module	
PLC-5/20	(Cable Diagram 1)	QPI-ABD-201 (TCP's) ^{*1}	Large Size GPs ^{*2}
		QPI-ABD-201 (TCP's) ^{*1}	Medium Size GPs ^{*3}

*1 Product manufactured by Total Control Products, Inc.

*2 When using the GP-470E, GP-570T, GP570T, GP-570S, GP-57JS, GP-570VM, GP-571T, GP-477RE, GP-577RT, GP-577RS, GP675T, GP-675S, GP870VM, GP-2500, GP-2600. For GP2000 Series, however, a bus conversion unit (PSL-CONV00) is required.

*3 When using the GP-270, GP270S, GP370L, GP370S, GP377RT.

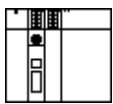
■ **AB PLC-5 Series (Using Remote I/O)**

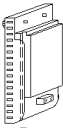
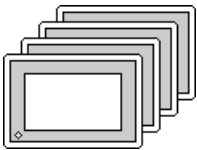
CPU	Cable Diagram	Unit	GP
		 Remote I/O	
PLC-5	(Cable Diagram 1)	QPI-ABR-201 (TCP's) ^{*1}	Large Size GPs ^{*2}
		QPJ-ABR-201 (TCP's) ^{*1}	Medium Size GPs ^{*3}

*1 Product manufactured by Total Control Products, Inc.

*2 When using the GP-470E, GP-570T, GP570T, GP-570S, GP-57JS, GP-570VM, GP-571T, GP-477RE, GP-577RT, GP-577RS, GP675T, GP-675S, GP-870VM, GP-2500, GP-2600. For GP2000 Series, however, a bus conversion unit (PSL-CONV00) is required.

*3 When using the GP-270, GP270S, GP370L, GP370S, GP377RT.

6.2.2 Cable Diagrams

Cable Diagram 1 (Using Data Highway Plus /Remote I/O)

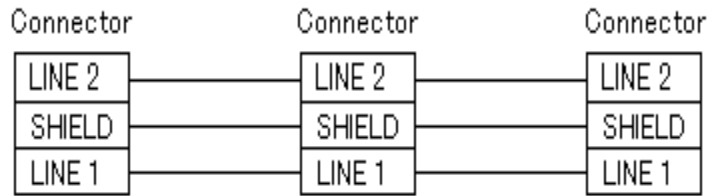

- The connector is supplied as an accessory for the PLC.
- Be sure to ground your PLC's FG terminal. For details, refer to the corresponding PLC manual
- Connect the FG line of the Shield cable to either the GP or PLC, depending on your environment. When using a connector hood and grounding the FG line, be sure to use an electrical conductor.

Connection to Data Highway Plus

The following drawing shows a GP connected to two PLC-5 processors on a Data Highway Plus network.

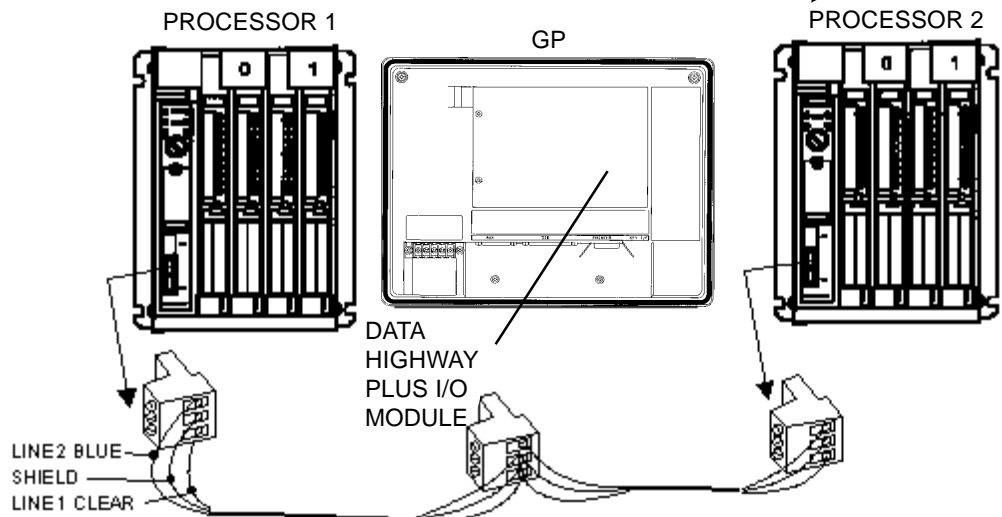

SLC 5/04 DH+ Connection

The drawing shows a possible configuration for DH+.

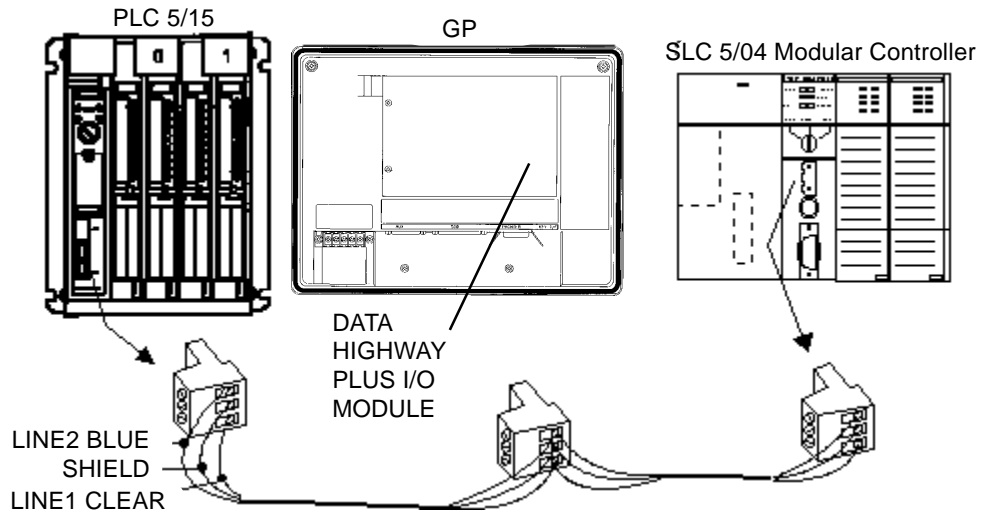

HMI-CAB-C83 Cable

This cable connects a single GP unit directly to the Rockwell (Allen-Bradley) SLC 500 Programming Port.

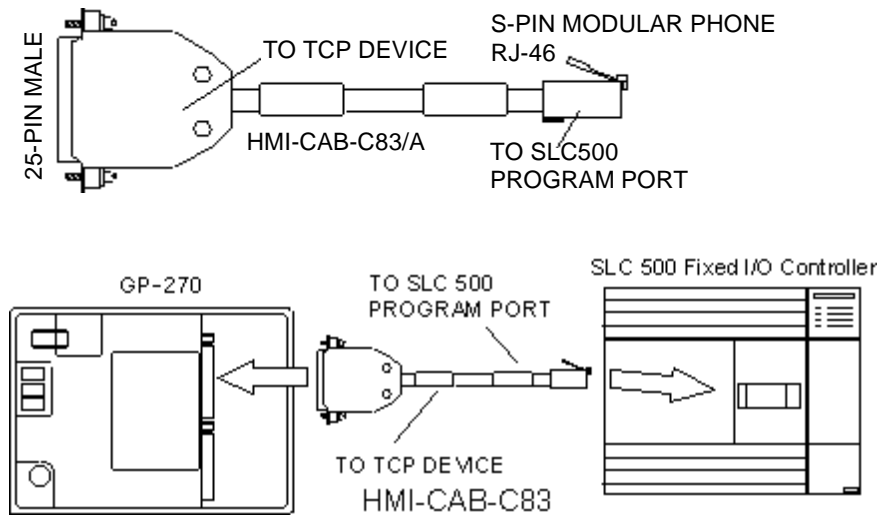

HMI-CAB-C84 Cable

This cable connects the GP's serial port to the Rockwell (Allen-Bradley) SLC 500 Programming Port.

The cable is designed to allow connection to additional devices such as an Rockwell (Allen-Bradley) 1747-PIC Interface Converter.



This cable is 6 feet (approximately 2 meters) long. Do not attempt to make it longer.

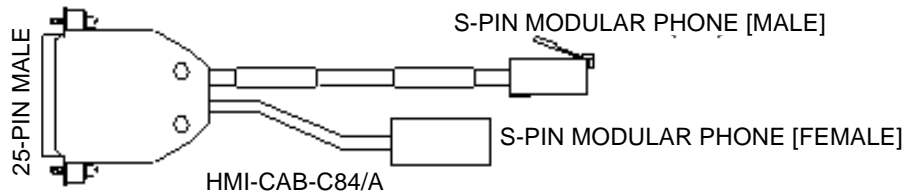

SLC 500 Network Connection for Programming Equipment (DH485)

This connection allows two devices to be connected to the PLC. In this case, a programming terminal can be connected to the PLC using a 1747-PIC Interface Converter connected to the HMI-CAB-C84 cable.

The drawing shows the connections for adding a second device to the network connection.

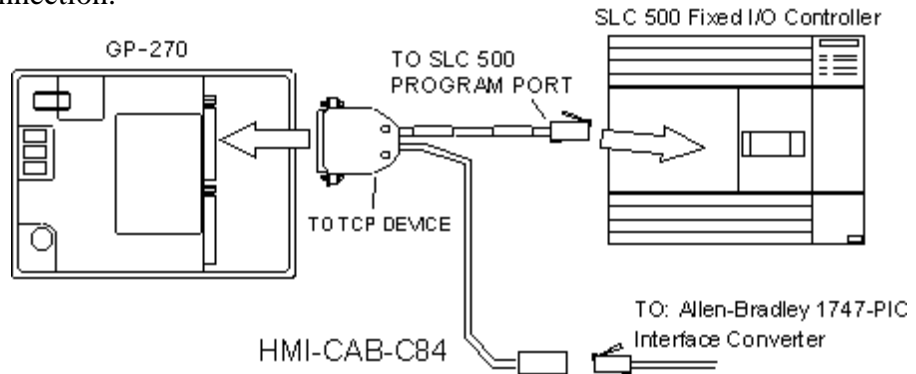

Connecting to a 1747 AIC Module (DH485)

Connect the HMI-CAB-C84 cable to the 1747 AIC Module as shown below.

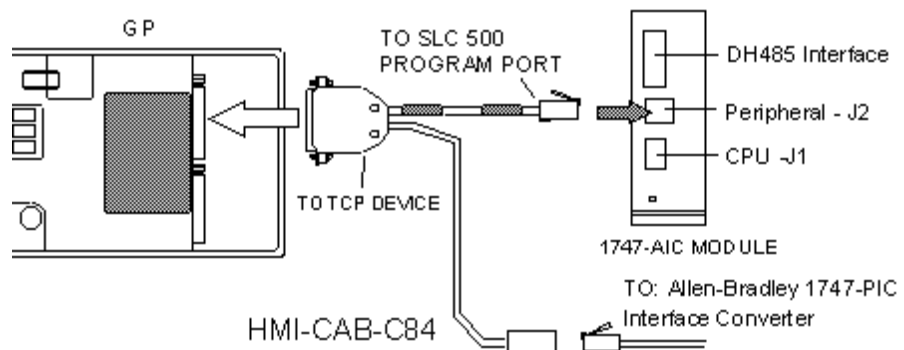

SLC 500 Net work Connection using 1747 AIC Link Couplers (DH485)

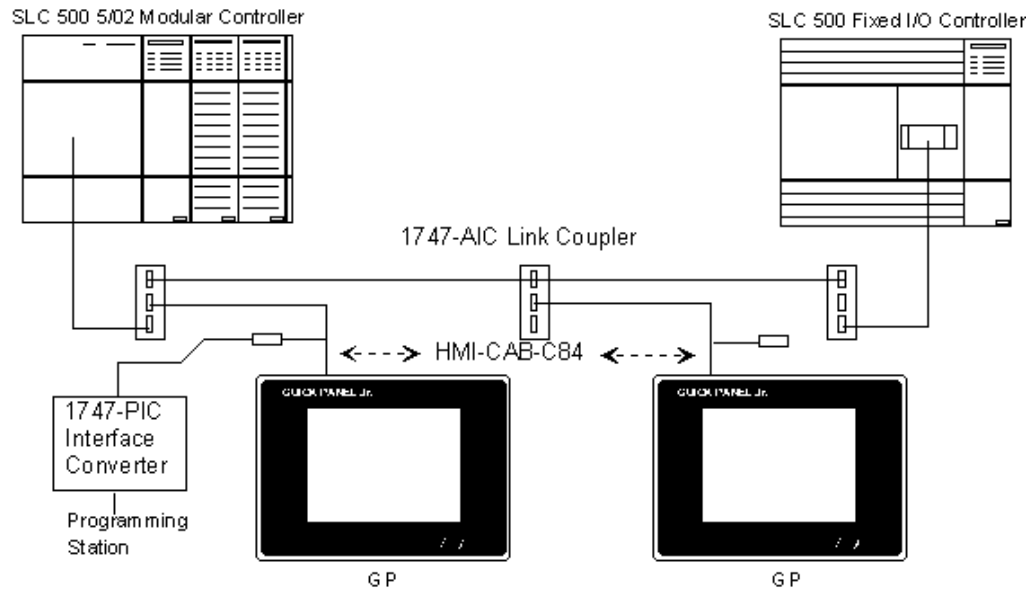

SLC 5/03 and SLC 5/04 DH485 Connections

You can connect channel 0 of the SLC 5/03 and SLC 5/04 modules to the 1747-PIC to make a connection to the DH485 network.

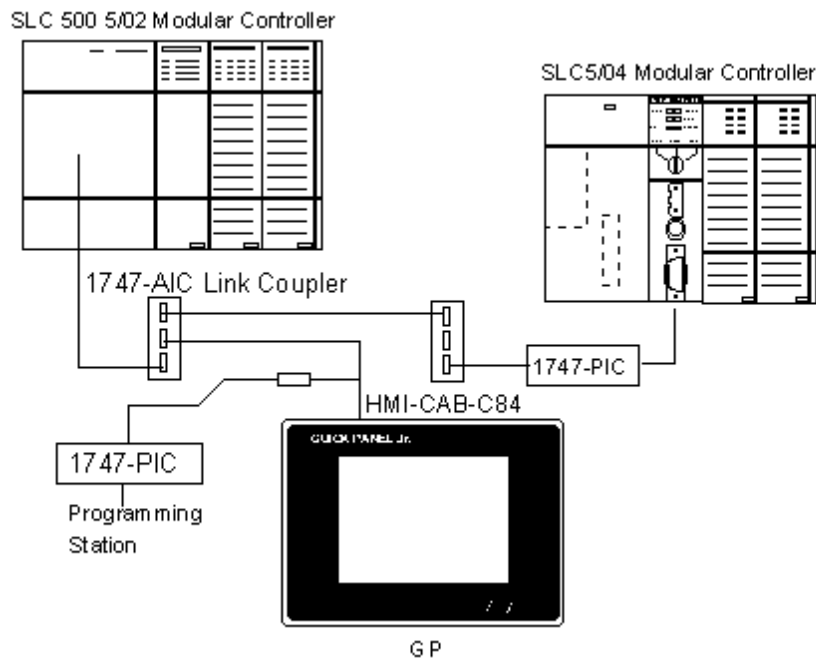

6.2.3 Supported Devices

■ AB SLC 500 Series (Using DH485 or Data Highway Plus)

Setup System Area here

Device	Bit Address	Word Address	Particulars
Status	S2:000/0 ~ S2:15/15	S2:000 ~ S2:15	SLC5/01
	S2:000/0 ~ S2:32/15	S2:000 ~ S2:32	SLC5/02
	S2:000/0 ~ S2:83/15	S2:000 ~ S2:83	SLC5/03
Bit	B3:000/0 ~ B3:255/15	B3:000 ~ B3:255	
Timer (TT: Timing Bit)	T4:000.TT ~ T4:255./TT	---	
	T10:000.TT ~ S255:255.TT	---	
Timer (DN: Completion Bit)	T4:000.DN ~ T4:255./DN	---	
	T10:000.DN ~ S255:255.DN	---	
Timer EN: Enable Bit)	T4:000.EN ~ T4:255.EN	---	
	T10:000.EN ~ S255:255.EN	---	
Timer (PRE: Current Value)	---	T4:000.PRE ~ T4:255.PRE	
	---	T10:000.PRE ~ S255:255.PRE	
Timer (Acc: Setup Value)	---	T4:000.ACC ~ T4:255.ACC	
	---	T10:000.ACC ~ S255:255.ACC	
Counter (CU: Up Count)	C5:000.CU ~ C5:255.CU	---	
	C10:000.CU ~ C255:255.CU	---	
Counter (CU: Down Count)	C5:000.CD ~ C5:255.CD	---	
	C10:000.CD ~ C255:255.CD	---	
Counter (DN: Completion Bit)	C5:000.DN ~ C5:255.DN	---	
	C10:000.DN ~ C255:255.DN	---	
Counter (OV: Overflow)	C5:000.OV ~ C5:255.OV	---	
	C10:000.OV ~ C255:255.OV	---	
Counter (UN: Underflow)	C5:000.UN ~ C5:255.UN	---	
	C10:000.UN ~ C255:255.UN	---	
Counter (UA: newly current value reading)	C5:000.UA ~ C5:255.UA	---	
	C10:000.UA ~ C255:255.UA	---	
Counter (Current Value)	---	C5:000.ACC ~ C5:255.ACC	
	---	C10:000.ACC ~ C255:255.ACC	
Counter (Current Value)	---	C5:000.PRE ~ C5:255.PRE	
	---	C10:000.PRE ~ C255:255.PRE	
Control (DN)	R6:000.DN ~ R6:255.DN	---	
	R10:000.DN ~ R255:255.DN	---	
Control (EN)	R6:000.EN ~ R6:255.EN	---	
	R10:000.EN ~ R255:255.EN	---	
Control (ER)	R6:000.ER ~ R6:255.ER	---	
	R10:000.ER ~ R255:255.ER	---	
Control (UL)	R6:000.UL ~ R6:255.UL	---	
	R10:000.UL ~ R255:255.UL	---	

L/H

■ **AB PLC-5 Series (Using Data Highway Plus)**

Setup System Area here.

Device	Bit Address	Word Address	Particulars
Output	0:0/0 ~ 0.37/17	---	
Input	1:0/0 ~ 1.37/17	---	
Status	S2:000/0 ~ S2:15/15	S2:000 ~ S2:15	
Bit	B3:000/0 ~ B3:999/15	B3:000 ~ B3:999	
Timer (TT: Timing Bit)	T4:000.TT ~ T4:999./TT	---	
	T8:000.TT ~ S999:999.TT	---	
Timer (DN: Completion Bit)	T4:000.DN ~ T4:999./DN	---	
	T8:000.DN ~ T999:999.DN	---	
Timer EN: Enable Bit)	T4:000.EN ~ T4:999./EN	---	
	T8:000.EN ~ T999:999.EN	---	
Timer (PRE: Current Value)	---	T4:000.PRE ~ T4:999.PRE	
	---	T8:000.PRE ~ S999:999.PRE	
Timer (Acc: Setup Value)	---	T4:000.ACC ~ T4:999.ACC	
	---	T8:000.ACC ~ T999:999.ACC	
Counter (CU: Up Count)	C5:000.CU ~ C5:999.CU	---	
	C8:000.CU ~ C999:999.CU	---	
Counter (CU: Down Count)	C5:000.CD ~ C5:999.CD	---	
	C8:000.CD ~ C999:999.CD	---	
Counter (DN: Completion Bit)	C5:000.DN ~ C5:999.DN	---	
	C8:000.DN ~ C999:999.DN	---	
Counter (OV: Overflow)	C5:000.OV ~ C5:999.OV	---	
	C8:000.OV ~ C999:999.OV	---	
Counter (UN: Underflow)	C5:000.UN ~ C5:999.UN	---	
	C8:000.UN ~ C999:999.UN	---	
Counter (UA: newly current value reading)	C5:000.UA ~ C5:999.UA	---	
	C8:000.UA ~ C999:999.UA	---	
Counter (Current Value)	---	C5:000.ACC ~ C5:999.ACC	
	---	C8:000.ACC ~ C999:999.ACC	
Counter (Current Value)	---	C5:000.PRE ~ C5:999.PRE	
	---	C8:000.PRE ~ C999:999.PRE	
Control (DN)	R6:000.DN ~ R6:999.DN	---	
	R8:000.DN ~ R999:999.DN	---	
Control (EN)	R6:000.EN ~ R6:999.EN	---	
	R8:000.EN ~ R999:999.EN	---	
Control (ER)	R6:000.ER ~ R6:999.ER	---	
	R8:000.ER ~ R999:999.ER	---	
Control (UL)	R6:000.UL ~ R6:999.UL	---	
	R8:000.UL ~ R999:999.UL	---	
Control (IN)	R6:000.IN ~ R6:999.IN	---	
	R8:000.IN ~ R999:999.IN	---	

L/H

AB PLC-5 Series (Using Data Highway Plus) (Continued)

 Setup System Area here.

Device	Bit Address	Word Address	Particulars
Control (FD)	R6:000.IN ~ R6:999.FD	---	L/H
	R8:000.IN ~ R999:999.FD	---	
Control (LEN)	---	R6:000.LEN ~ R6:999.LEN	
	---	R10:000.LEN ~ R999:999.LEN	
Control (POS)	---	R6:000.POS ~ R6:999.POS	
	---	R10:000.POS ~ R999:999.POS	
Integral Number1 (N)	N7:000/0 ~ N7:999/15	N7:000 ~ N7:999	
	N8:000/0 ~ N:999/15	N8:000 ~ N:999:999	
Floating point (F)	---	F8:000 ~ F999:999	
ASCII (A)	---	A12:000 ~ A999:999	H/L



- The range of supported devices may differ depending on your CPU.
- These maximum ranges may not be supported by some PLC configurations.

■ AB PLC-5 Series (Using Remote I/O)

Device	Bit Address	Word Address	Particulars
Input	I:000/00 ~ I:377/17	I:000 ~ I:377	
Output	O:000/00 ~ O:377/17	O:000 ~ O:377	
Block Transfer (Read)	BTR:0000:00/00 ~ BTR:3771:63/15	BTR:0000:00 ~ BTR:3771:63	*1
Block Transfer (Write)	BTW:0000:00/00 ~ BTW:3771:63/15	BTW:0000:00 ~ BTW:3771:63	*1

**1 Block Transfer Read & Write (BTR & BTW) must be configured in the Environment Setup (See next section) before being able to use these addresses.*



- These maximum ranges may not be supported by some PLC configurations.
- This driver cannot allocate the System Data Area for the PLC's Device Addresses.

6.2.4 Environment Setup

- System Area and Read Area are not supported by Remote I/O.
- When entering the GP OFFLINE mode's Set up Operation Surroundings, be sure to select the [GP-PRO/PBIII for Windows] Edit mode.



- *These settings cannot be set using the GP's OFFLINE Communication Settings. Be sure to use GP-PRO/PBIII for this.*
- *These settings cannot be set using the GP's Environment Settings. Be sure to use GP-PRO/PBIII for this.*
- *E and K-tags cannot use the "Indirect" Setting.*
- *32 bit-length data cannot be written. (DH485)*
- *K-tag text (columns) data cannot be written. (DH485)*
- *After the H-tag starts (is triggered), data cannot be read (out).*
- *After the S-tag starts (is triggered), data cannot be read (out).*
- *The Trend graph's group data display's PLC device designation feature cannot be used.*
- *The System Area and the Read (In) Area cannot be used. (Only with Remote I/O)*
- *The data backup feature cannot be used (Data Highway Plus, Remote I/O).*
- *D-Script 's Memory Copy and Offset Address features cannot be used.*
- *The Logging and Filing Data features cannot be used.*
- *2-Way Driver cannot be used.*

■ **AB SLC 500 Series (Using DH485)**

GP Setup		PLC Setup	
Baud Rate	19200 bps	---	
Data Length	8 bits	---	
Stop Bit	1 bit	---	
Parity Bit	Even	---	
Data Flow Control	ER Control	---	
Communication Format (RS-232C)	RS-232C *1	---	
Communication Format (RS-422)	2-wire type *2	---	
Unit No.	---	---	
Source ID	0	---	
Destination ID	1	Node Address	1
Maximum ID	31	Maximum Address	31

* 1 Set the Communication Format to RS-232C when using the HMI-CAB-C84 cable.

* 2 Set the Communication Format to RS-422 when using the HMI-CAB-C83 cable.

■ **AB SLC 500 Series (Using Data Highway Plus)**

GP Setup		PLC Setup	
Baud Rate	---	---	---
Data Length	---	---	---
Stop Bit	---	---	---
Parity Bit	---	---	---
Data Flow Control	---	---	---
Communication Format (RS-232C)	---	---	---
Communication Format (RS-422)	---	---	---
Unit No.	---	---	---
Source ID *1	0	---	---
Destination ID *1	1	Node Address	1

* 1 These settings can be made by “option” of GP system setting in Drawing Software (PRO/PBIII for Windows). It is not possible to set from the GP's OFFLINE menu.

■ **AB PLC 5 Series (Using Data Highway Plus)**

GP Setup		PLC Setup	
Baud Rate	57600 bps	Baud Rate	57600 bps
Data Length	---	---	---
Stop Bit	---	---	---
Parity Bit	---	---	---
Data Flow Control	---	---	---
Communication Format (RS-232C)	---	---	---
Communication Format (RS-422)	---	---	---
Unit No.	---	---	---
Source ID ^{*1}	0	---	---
Destination ID ^{*1}	1	Node Address	1

** 1 These settings can be set via the GP-PRO/PBIII [Option] area. These settings cannot be set using the GP's OFFLINE Mode.*

■ **AB PLC-5 Series (Using Remote I/O)**

If you select the PLC type setting as "Remote I/O" for your GP-PRO/PBIII project, you will also need to configure your GP unit's I/O addresses. After the project is setup, the following configuration window can be found by clicking on the Mode Settings area's "Rack Setup" button.

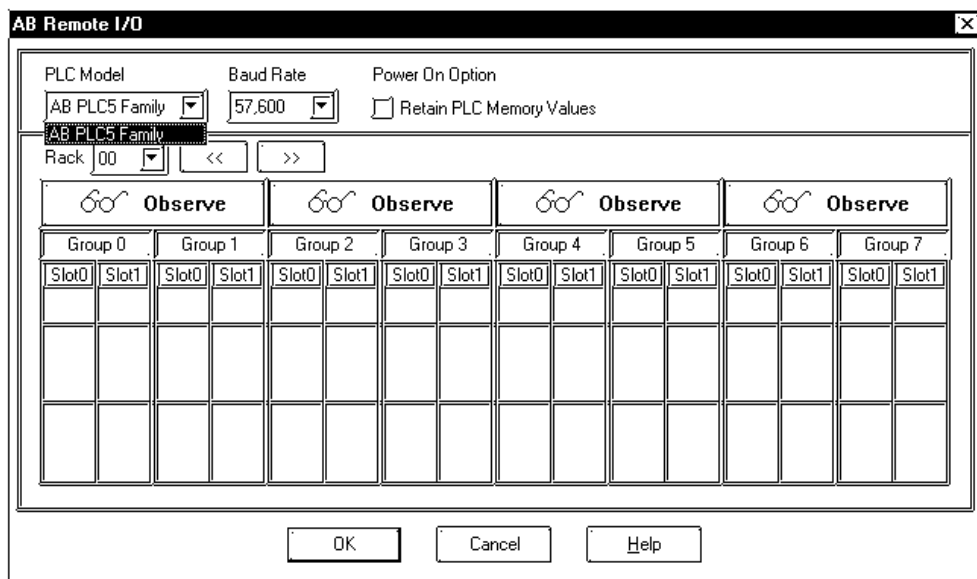

◆ **PLC Model**

Currently, only the AB PLC 5 Family is supported.

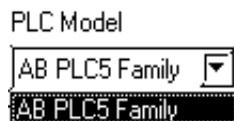

◆ **Baud Rate**

Select the baud rate used for the Remote I/O network. This selection must match that of the intended network.



Early versions of the QPI-ABR-001 RIO modules are not capable of operating at 230K baud.

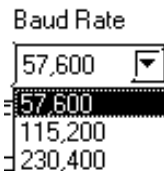

◆ **Retain Memory Values**

To retain the memory values of all data input and all Block Transfer Reads (BTR), click on the checkbox titled "Retain PLC Memory Values. If this box is not checked, all data values will be set to 0 when the power is cycled (turned off).

◆ **Rack Addresses**

A rack corresponds to the I/O rack number of the I/O chassis in which you have placed the target I/O module. For rack emulation, the target I/O module is the emulated rack. The valid ranges for rack numbers are shown below. You cannot do a block transfer to a rack above address 17.

Processor	Maximum No. of Racks	Valid Range (octal)
PLC-5/10, -5/12, -5/15	4	00 - 03
PLC -5/25, -5/30	8	00 - 07
PLC-5/40, -5/40L	16	00 - 17
PLC-5/60, -5/60L	24	00 - 27

1. Observation Mode

When you first start a project using Remote I/O, all racks are in OBSERVE mode, which allows the target display to listen to all discrete I/O transfers on the Remote I/O link.

An Allen Bradley rack corresponds to 128 input bits and 128 output bits of defined PLC data table memory. In the PLC memory, a "data table" reserves 128 bits for both input and output. This data table then allows the PLC to communicate with all other devices. No matter what I/O scheme (configuration) is being used, 1, 1/2, 1/4 slot addressing, the limit per rack is 128 bits.

When you select two (2) slot addressing, each pair of slots is assigned to the corresponding pair of words in the input and output image tables. You assign one I/O rack number to eight (8) I/O groups. The following drawing shows a rack of I/O that has been set up to use 2-slot addressing.

2. Emulate Mode

You can also have your GP emulate a rack for only discrete I/O, or configure it to work with "Block Transfer" read and write operations.

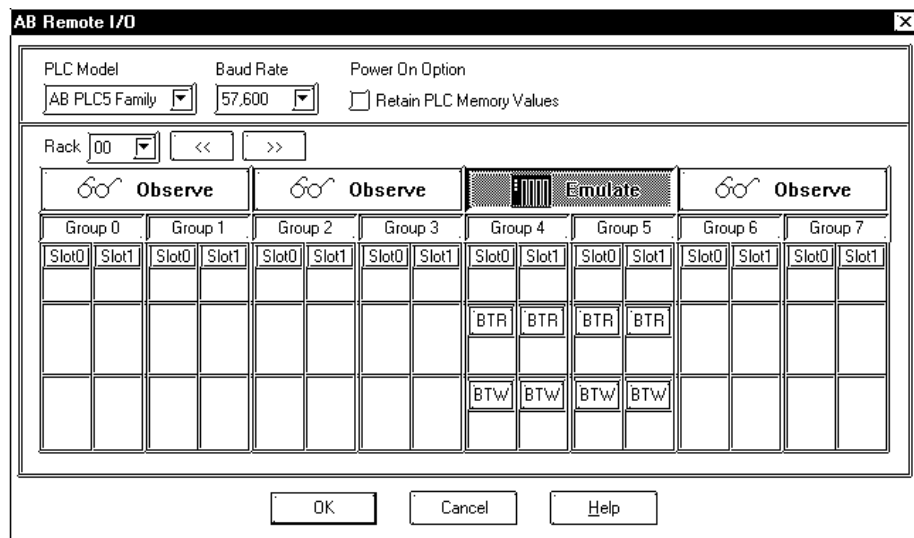

■ Discrete I/O

From the configuration shown above (this window can be called up using the Project Setup area Mode tab's "Rack Setup" selection), select the areas of the master PLC's I/O table that the GP should emulate.



Caution

These areas should not be used by any other device.

In the above example, this GP will emulate RACK 01, Groups 4 & 5. This means that the GP can use addresses O:014/00 to O:014/17 and I:014/00 to I:014/17.

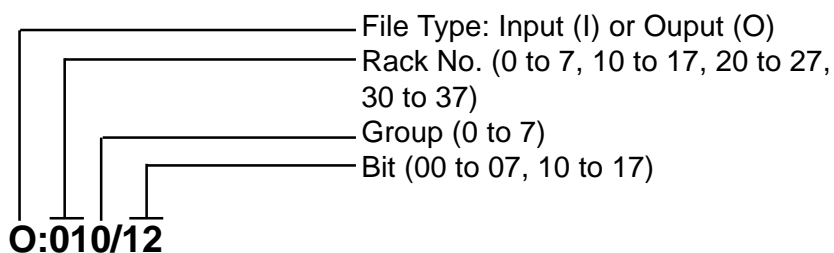

Block Transfer

"Block Transfer" commands allow you to send and receive data to and from a PLC.

Use the configuration window shown below (called up by clicking on the Project Setup area Mode tab's [Option]) to select the areas of the master PLC's I/O table that should be used by the GP for Block transfer (Read or Write) and how many words (0 to 64) should be transferred.



These areas should not be used by any other device.

The block transfer area selected here must be accompanied by an equivalent Block Transfer command in the PLC ladder program.

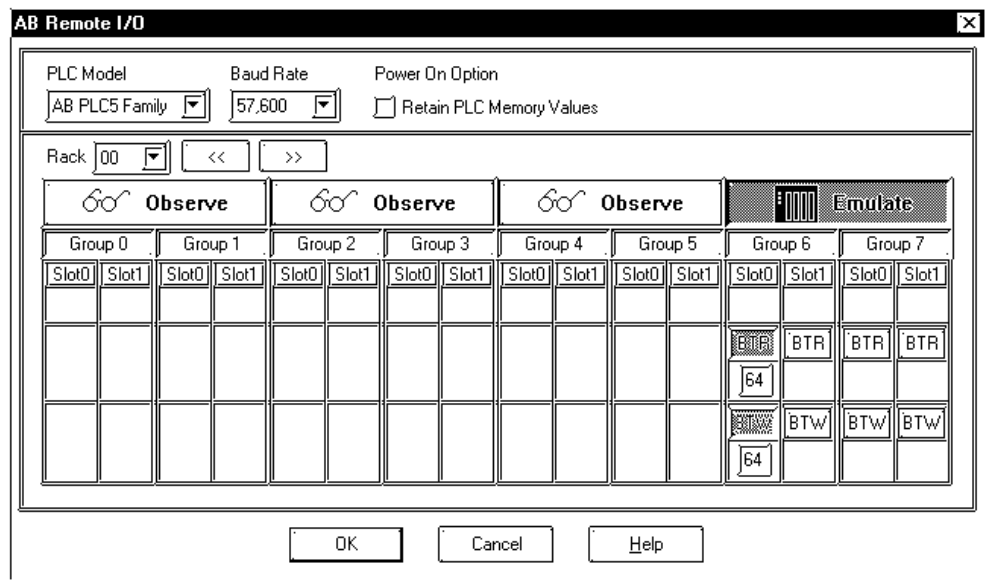

The difference between the BTR and BTW data types is very important. A BTR is a "Block Transfer Read" from the GP to the PLC, which means the GP can write to this area. A BTW is a "Block Transfer Write" from the PLC to the GP, which means the GP can read data from this area.

In the above example, the GP is using Rack 07, Group 6, Slot 0 for Block Transfer. Slot 0 is set with a BTR and BTW of 64. This means that the GP can use addresses BTR:0760:00 to BTR:0760:63, and BTW:0760:00 to BTW:0760:63.

BTR:0760:00/00

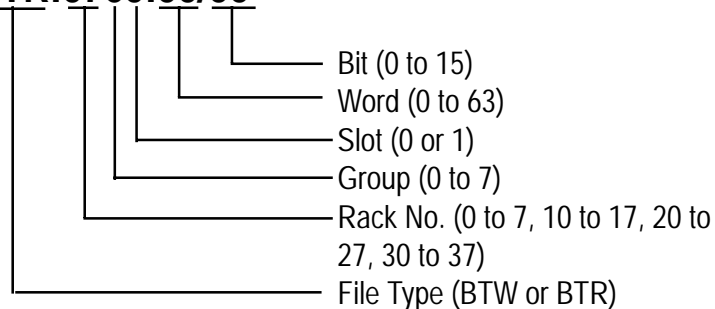

The ladder program below shows how to transfer data from the GP to N10:0 to 63 and data (from the PLC's) N:11:0 to 63 into the GP.

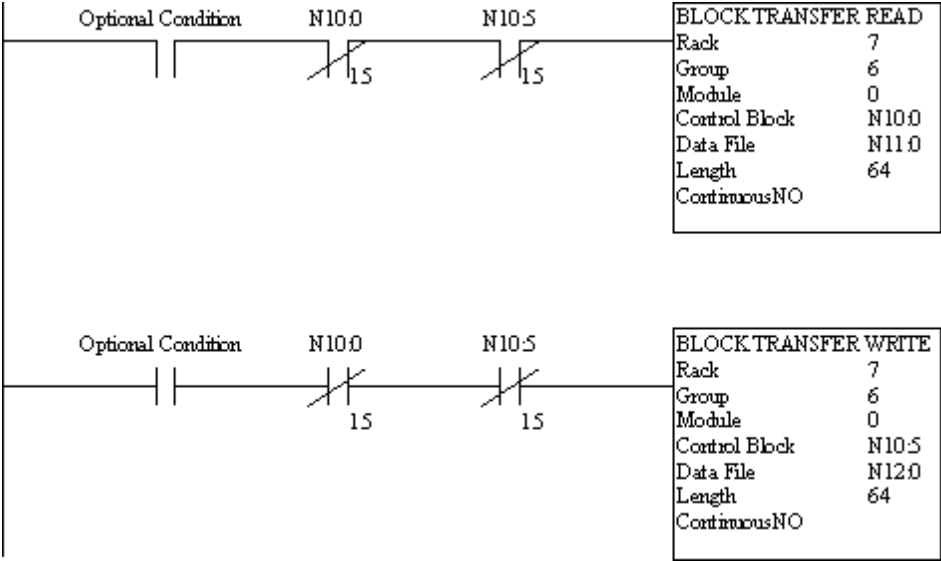





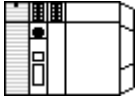

6.3 Modicon

6.3.1 System Structure

■ Modicon Modbus (GP Slave)

Host	Cable Diagram	GP
		
Modbus Master	RS-232C (Cable Diagram 1) RS-422 (Cable Diagram 2)	GP Series (Slave)

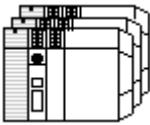
■ Modicon Modbus Plus (CPU Direct Connection)

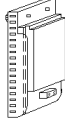
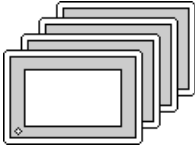
CPU	Cable Diagram	Unit	GP
		 Modbus Plus Module	
884, 984A, 984B	Modbus Plus cable	QPI-MBP-201 (TCP's) ^{*1} QPJ-MBP-201 (TCP's) ^{*1}	Large Size GPs ^{*2} Medium Size GPs ^{*3}

*1 Product manufactured by Total Control Products, Inc.

*2 When using the GP-470E, GP-570T, GP570T, GP-570S, GP-57JS, GP-570VM, GP-571T, GP-477RE, GP-577RT, GP-577RS, GP-675T, GP-675S, GP-870VM, GP-2500, GP-2600. For GP2000 Series, however, a bus conversion unit (PSL-CONV00) is required.

*3 When using the GP270L, GP270S, GP370L, GP370S, GP377RT

6.3.2 Cable Diagrams

Cable Diagram 1 (RS-232C)

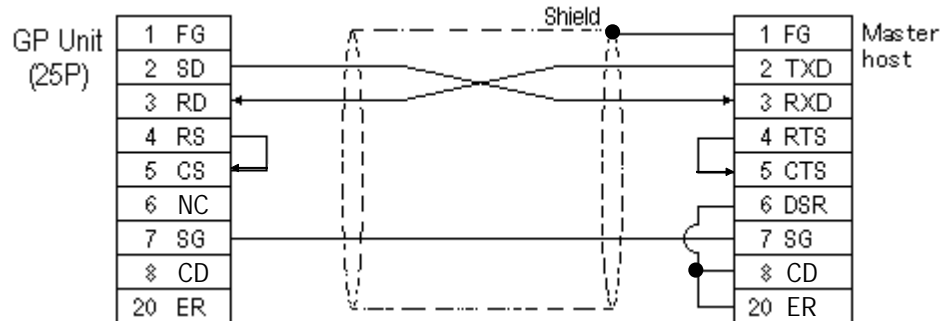

Cable Diagram 2 (RS-422)

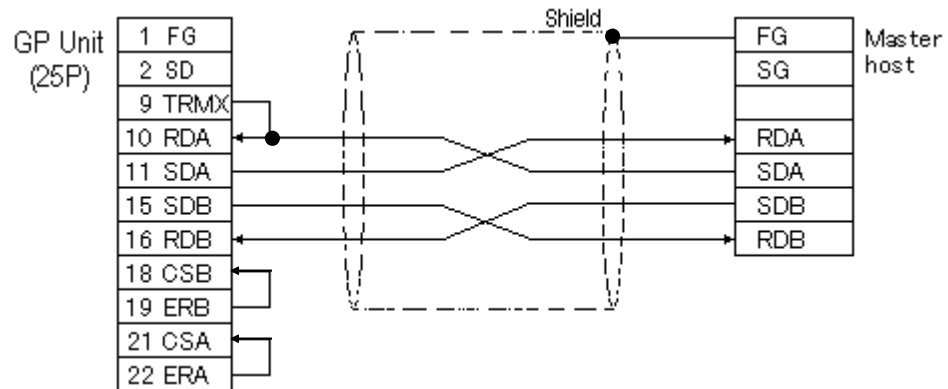

- When using Digital's RS-422 connector terminal adapter GP070-CN10-0

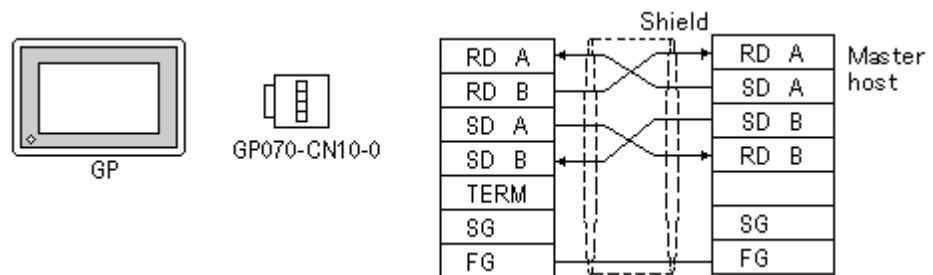

- When using Digital's RS-422 Cable, GP230-IS11-0

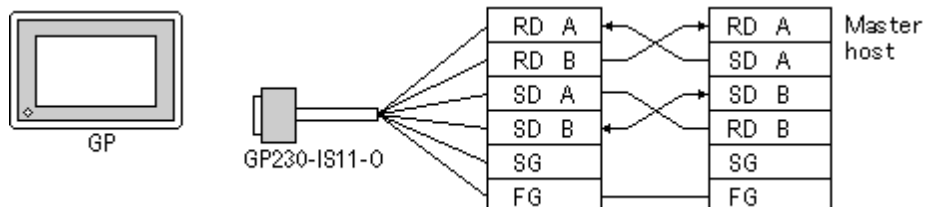

Note: Wiring varies depending on types of master host.

Modbus Slave Diagram

The drawing shows how a GP might be connected as a slave device.

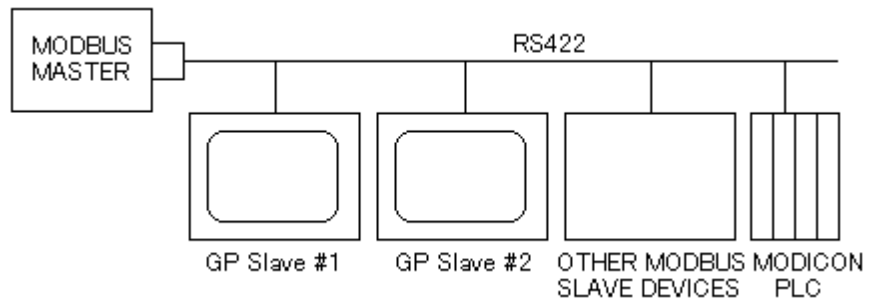

Sample Network (Modbus Plus)

Each node has an LED indicator that flashes patterns to show its status on the network. A simple network consists of two or more nodes connected to a single section.

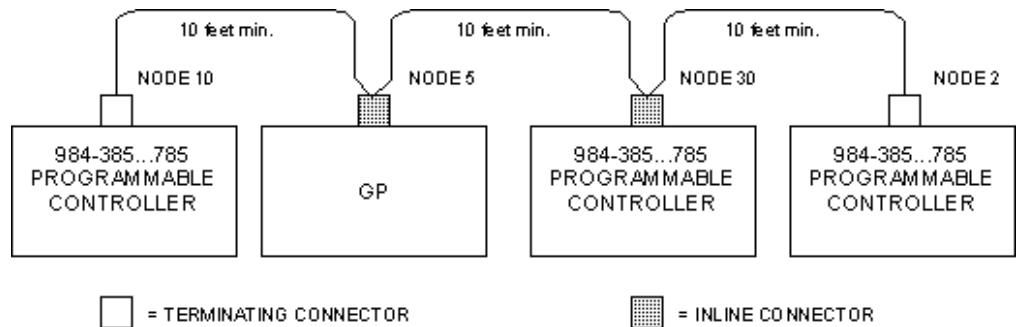

6.3.3 Supported Devices

■ **Modicon Modbus (GP Slave)**

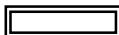
 Setup System Area here.

Device	Bit Address	Word Address	Particulars
Output Register	---	40001 ~ 49999	L/H

■ **Modicon Modbus Plus**

 Setup System Area here.

Device	Bit Address	Word Address	Particulars
Output Bit	00001 ~ 08192	---	*1
Input Bit	10001 ~ 18192	---	*1*2
Output Relay	---	40001 ~ 49999	L/H
Input Register	---	30001 ~ 39999	*2

* 1 Can also specify a word (16 bit data).

* 2 Cannot perform data write.

6.3.4 Environment Setup

■ Modicon Modbus (GP Slave)

GP Setup		COM Port	
Baud Rate	19200 bps	Baud Rate	19200 bps
Data Length	8 bits	Data Length	RTV (8 bits)
Stop Bit	1 bit	Stop Bit	1 bit
Parity Bit	Even	Parity Bit	EVEN
Data Flow Control	ER	Data Flow Control	ER
Communication Format (RS-232C)	RS-232C	Communication Format (RS-232C)	RS-232C
Communication Format (RS-422)	RS422	Communication Format (RS-422)	RS422
Unit No.	1	Unit No. ^{*1}	1

**1 Unit No. shows the number of the GP itself.*

■ Modicon Modbus Plus

GP Setup		COM Port	
Baud Rate	---	---	---
Data Length	---	---	---
Stop Bit	---	---	---
Parity Bit	---	---	---
Data Flow Control	---	---	---
Communication Format (RS-232C)	---	---	---
Communication Format (RS-422)	---	---	---
Unit No.	---	---	---
Station Address ^{*1}	1	---	---
Route Selection ^{*2}	1	Station Address	2

** 1 Set the station address with the Dip Switch for Modbus Plus module (QPI-MBP-201/QPJ-MBP-201).*

** 2 Route Selection can be made via the GP-PRO/PBIII System Settings area's "Option" menu.*



- **These settings cannot be changed via the GP's OFFLINE mode. You must use the GP-PRO/PBIII software.**
- **E and K-tags cannot use the "Indirect" Setting.**
- **After the H-tag starts (is triggered), data cannot be read (out).**
- **After the S-tag starts (is triggered), data cannot be read (out).**
- **The Trend graph's group data display's PLC device designation cannot be made.**
- **The data backup feature cannot be used, (only with Modbus PLUS).**
- **D-Script 's Memory Copy and Offset Address features cannot be used.**
- **The Logging and Filing Data features cannot be used.**
- **2-Way Driver cannot be used.**

Modbus Plus Adapter Module

The following drawing illustrates the Modbus Plus Adapter I/O module on a GP270 display.

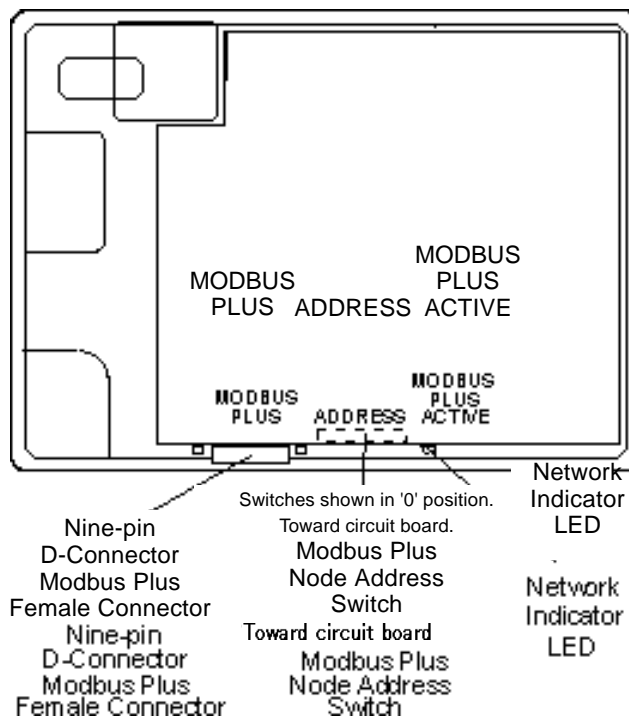

Station Address Switches

Station Address	Switch Positions					
	1	2	3	4	5	6
	(1)	(2)	(4)	(8)	(16)	(32)
1	0	0	0	0	0	0
2	1	0	0	0	0	0
26	1	0	0	1	1	0
32	1	1	1	1	1	0
64	1	1	1	1	1	1

 **Note:** Add one to switch a desired address setting. Switch down=ON=0.

Route Strings

Route strings are added to a variable name to locate the PLC address, which may be at the end of a chain. Each point on the link must be defined in order to arrive at the selected processor. For example, a route might be 60, 20, and 1, which would appear at the end of the variable name as 4100_60.20.1. If you define Route A as 60.20.1, then the variable name can be 4100_A. There are 26 route menus, designated A through Z.

The above setting can be made via the GP-PRO/PBIII System Settings area's "Option" menu.

7 Ethernet Connections

This chapter describes the system configuration of PLC made by various manufacturers and the GP [Ethernet], and explains the supported devices and examples of setting up the operating environment.



Important *If Ethernet communication is performed using by the memory link method are used,*



Reference *Refer to the GP70 Series Memory Link Communication Protocol Manual. (GP Ethernet I/F Unit)*

7.1 Connectable PLCs

The following tables list the PLCs that can be connected and used with the GP.

	Series Names	CPU	Ethernet Unit	Comments	PLC type in PRO/PBIII
M I T S U B I S H I	MELSEC-A	A2A A3A A2U-S1 A2N	AJ71E71	When using GP70, GP77R series units and the GP-2501T, an Ethernet-compatible unit is required.	MITSUBISHI MELSEC-A(ETHER)
		A2US	A1SJ71E71		
	MELSEC-Q (Q mode CPU)	Q02CPU Q02HCPU Q06HCPU Q12HCPU Q25HCPU	QJ71E71 QJ71E71-B2		
	MELSEC-QnA	Q2A Q2A-S1 Q3A Q4A Q4AR	AJ71QE71 AJ71QE71-B5	When using GP77R series units and the GP-2501T, an optional Ethernet unit is required.	MITSUBISHI MELSEC-Q(ETHER)
		Q2AS Q2ASH Q2AS-S1 Q2ASH-S1	A1SJ71QE71-B2 A1SJ71QE71-B5		
T O S H I B A	PROSEC-T	T3H	EN311	When using GP70, GP77R series units and the GP-2501T, an Ethernet-compatible unit is required.	TOSHIBA PROSEC-T(ETHER)
		T2N	PU-235N PU-245N		



Careful! *When using the MELSEC-Q Series Multi CPU system, only Ethernet Unit's Control CPU that are connected to the GP can be accessed.*



	Series Name	CPU	Ethernet Unit	Comments	PLC type in PRO/PBIII
Y O K O G A W A	FACTORY ACE FA-M3	F3SP20-0N F3SP21-0N F3SP25-2N F3SP30-0N F3SP35-5N F3SP28-3N F3SP38-6N F3SP53-4H F3SP58-6H	F3LE01-5T	When using GP70, GP77R series units and the GP-2501T, an Ethernet-compatible unit is required.	YOKOGAWA FA-M3 (ETHER)
O M R O N	SYSMAC CS1 Series	CS1H-CPU67 CS1H-CPU66 CS1H-CPU65 CS1H-CPU64 CS1H-CPU63 CS1G-CPU45 CS1G-CPU44 CS1G-CPU43 CS1G-CPU42	CS1W-ETN01	When using GP77R series units and the GP-2501T, an optional Ethernet unit is required. This units should not be used to connect with Pro-Server.	OMRON SYSMAC-CS1 (ETHER)

7.2 Mitsubishi Electric

7.2.1 System Structure for Ethernet Connection

This section explains the system structure for the Ethernet connection between a PLC made by Mitsubishi Electric and the GP.

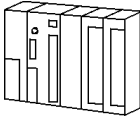
■ MELSEC-A Series/AJ71E71, A1SJ71E71 (using Ethernet Unit)

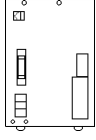
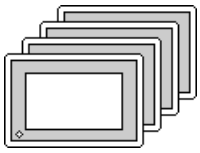

CPU	Link I/F	Cable Diagram	Cables	Unit ^{*2}	GP/GLC
	 Ethernet Unit				
A2A, A3A, A2N, A2U-S1	AJ71E71		Ethernet cable (conforming to the IEEE802.3)	Digital's GP Ethernet I/F Unit (GP070-ET11/GP070- ET41) GP77R Series Multi Unit E (GP077-MLTE11) GP-377R Series Multi Unit (GP377-MLTE11)	GP/GLC Series ^{*1}
A2US	A1SJ71E71				

**1 The Ethernet-compatible GP/GLC units include the GP-470E, GP-570T, GP-570S, GP-570L, GP-570VM, GP-571T, GP-57JS, GP-675T, GP-675S, GP-477RE, GP-577RT, GP-577RS, GP-377RT, GP-2400T, GP-2500T, GP-2501T, GP-2600T and GLC-2400T.*

**2 Except for the GP-2501T, all GP2000 and GLC2400 Series units can also use their built-in Ethernet ports. When attaching the optional Ethernet unit to a GP2000 Series (except for the GP-2400T) unit, the optional Bus Conversion Unit (PSL-CONV00) is required. The GP-2400T and the GLC-2400T cannot use this unit.*

Reference For connecting the cable, refer to “3.2 Connecting the cable” in the User’s Manual for the GP70 Series GP Ethernet Interface Unit.

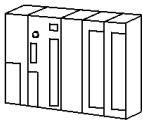
■ MELSEC-Q Series

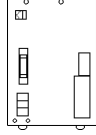
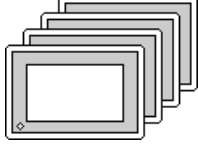
CPU	LinkI/F	Cable Diagram	Cables	Unit ²	GP/GLC
	 Ethernet Unit				
Q02CPU Q02HCPU Q06HCPU Q12HCPU Q25HCPU	QJ71E71 QJ71E71-B2		Ethernet cable (conforming to the IEEE802.3)	Digital's GP Ethernet I/F Unit GP070-ET11 GP070-ET41 GP377-MLTE11 GP377-MLTE41 GP077-MLTE41	GP/GLC Series ¹

*1 The Ethernet-compatible GP/GLC units include the GP-477RE, GP-577RT, GP-577RS, GP-377RT, GP-2400T, GP-2500T, GP-2501T, GP-2600T and GLC-2400T.

*2 Except for the GP-2501T, all GP2000 and GLC2400 Series units can also use their built-in Ethernet ports. When attaching the optional Ethernet unit to a GP2000 Series (except for the GP-2400T) unit, the optional Bus Conversion Unit (PSL-CONV00) is required. The GP-2400T and the GLC -2400T cannot use this unit.

Reference For connecting the cable, refer to the User Manuals for each Option Unit. When using GP2000 and GLC2000 Series units, refer to the GP2000 and the GLC2000 Series User Manual.

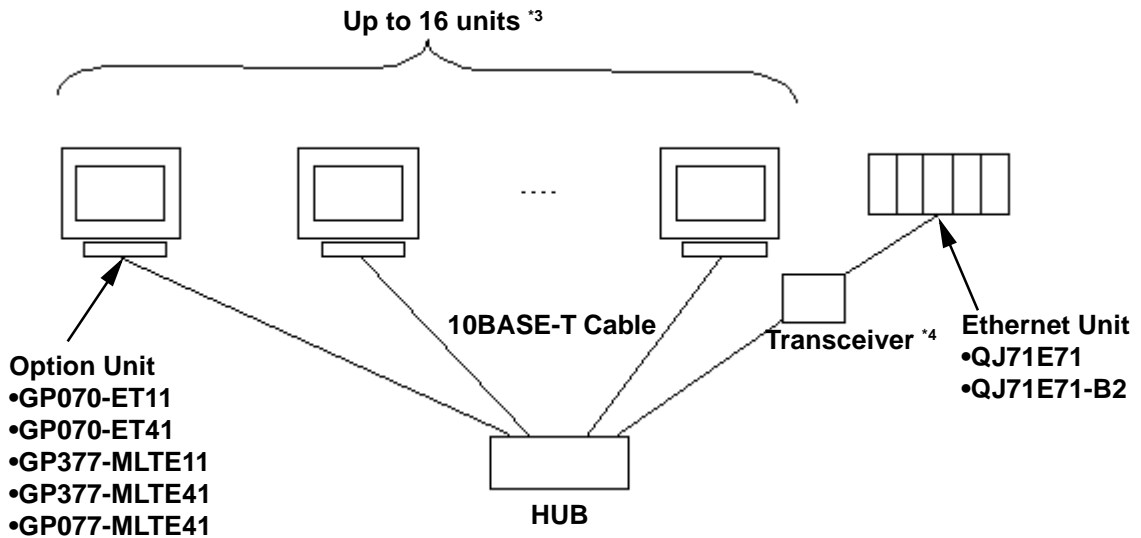

◆ Connction Structure



*3 When transmitting data via the PLC's OPEN Setting feature instead of the Auto OPEN UDP Port feature, up to 16 GP units can be connected. Also, when using the PLC's Auto Open UDP Port feature, there is no limitation for the number of GP units that can be connected.

*4 When using a 10BASE-5 or a 10BASE-2 cable with the Mitsubishi PLC, use a transceiver to connect this cable with the 10BASE-T cable.

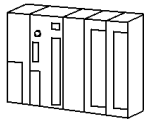
■ MELSEC-QnA Series

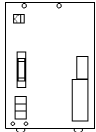
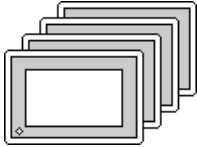
CPU	Link I/F	Cable Diagram	Cables	Unit ^{*2}	GP/GLC
	 Ethernet Unit				
Q2A Q2A-S1 Q3A Q4A Q4AR	AJ71QE71 AJ71QE71-B5		Ethernet cable (conforming to the IEEE802.3)	Digital's GP Ethernet I/F Unit GP070-ET11 GP070-ET41 GP377-MLTE11 GP377-MLTE41 GP077-MLTE41	GP/GLC Series ^{*1}
Q2AS Q2AS-S1 Q2ASH Q2ASH-S1	A1SJ71QE71-B2 A1SJ71QE71-B5				

**1 The Ethernet-compatible GP/GLC units include the GP-477RE, GP-577RT, GP-577RS, GP-377RT, GP-2400T, GP-2500T, GP-2501T, GP-2600T and GLC-2400T.*

**2 Except for the GP-2501T, all GP2000 and GLC2400 Series units can also use their built-in Ethernet ports. When attaching the optional Ethernet unit to a GP2000 Series (except for the GP-2400T) unit, the optional Bus Conversion Unit (PSL-CONV00) is required. The GP-2400T and the GLC -2400T cannot use this unit.*

Reference For connecting the cable, refer to the User Manuals for each Option Unit. When using GP2000 and GLC2000 Series units, refer to the GP2000 and the GLC2000 Series User Manual.

◆ Connection Structure

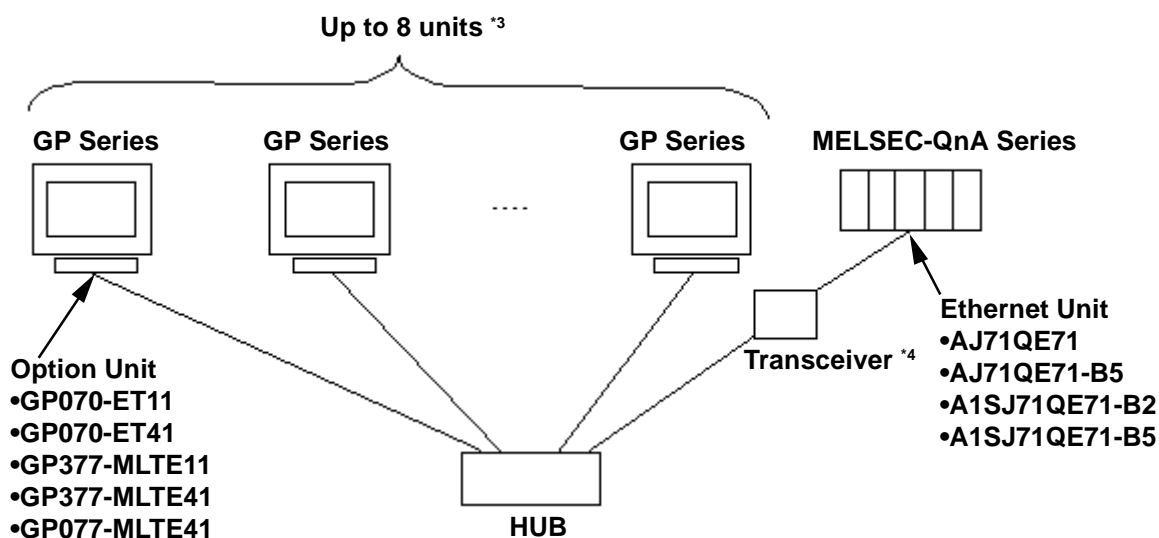

**3 When transmitting data via the PLC's OPEN Setting feature instead of the Auto OPEN UDP Port feature, up to 8 GP units can be connected. Also, when using the PLC's Auto Open UDP Port feature, there is no limitation for the number of GP units that can be connected.*







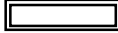

**4 When using a 10BASE-5 or a 10BASE-2 cable with the Mitsubishi PLC, use a transceiver to connect this cable with the 10BASE-T cable.*

7.2.2 Supported Devices

The following describes the range of devices supported by the GP.

■ MELSEC-A Series

 Setup System Area here.

Device	Bit Address	Word Address	Particulars
Input Relay	X0000 - X1FFF	X0000 - X07F0	
Output Relay	Y0000 - Y1FFF	Y0000 - Y07F0	
Internal Relay	M0000 - M8191	M0000 - M8176	
Latch Relay	L0000 - L8191	---	
Special Relay	M9000 - M9255	M9000 - M9240	
Annunciator	F0000 - F2047	F0000 - F2032	
Link Relay	B0000 - B0FFF	---	
Timer (contact)	TS0000 - TS2047	---	
Timer (coil)	TC0000 - TC2047	---	
Counter (contact)	CS0000 - CS1023	---	
Counter (coil)	CC0000 - CC1023	---	
Timer (current value)	---	TN0000 - TN2047	
Counter (current value)	---	CN0000 - CN1023	
Data Register	---	D0000 - D6143	
Special Register	---	D9000 - D9255	
Link Register	---	W0000 - W0FFF	
File Register	---	R0000 - R8191	

L/H

 **Note:** The range of supported devices may differ depending on your CPU. For the range of supported devices for each CPU, refer to the User's Manual for Model AJ71E71 Interface Unit by Mitsubishi Electric.

■ MELSEC-Q/MELSEC-QnA Series

 Setup System Area here.

Device	Bit Address	Word Address	Particulars
Input Relay	X0000 - X1FFF	X0000 - X1FF0	
Output Relay	Y0000 - Y1FFF	Y0000 - Y1FF0	
Internal Relay	M0000 - M32767	M0000 - M32752	
Special Relay	SM0000 - SM2047	SM0000 - SM2032	
Latch Relay	L0000 - L32767	L0000 - L32752	
Annunciator	F0000 - F32767	F0000 - F32767	
Edge Relay	V0000 - V32767	V0000 - V32752	
Step Relay	S0000 - S8191	S0000 - S8176	
Link Relay	B0000 - B7FFF	B0000 - B7FF0	
Special Link Relay	SB000 - SB7FF	SB000 - SB7F0	
Timer (contact)	TS00000 - TS23087	_____	
Timer (Coil)	TC00000 - TC23087	_____	
Aggregate Timer (contact)	SS00000 - SS23087	_____	
Aggregate Timer (coil)	SC00000 - SC23087	_____	
Counter (contact)	CS00000 - CS23087	_____	
Counter (coil)	CC00000 - CC23087	_____	
Timer (current value)	_____	TN00000 - TN23087	
Aggregate Timer (current value)	_____	SN00000 - SN23087	
Counter (current value)	_____	CN00000 - CN23087	
Data Register	_____	D00000 - D25983	
Special Register	_____	SD0000 - SD2047	
Link Register	_____	W0000 - W657F	
Special Link Register	_____	SW000 - SW7FF	
File Register (Normal)	_____	R0000 - R32767	
File Register (Serial)	_____	0R0000 - 0R7FFF	
	_____	1R0000 - 1R7FFF	
	:	:	:
	_____	30R0000 - 30R7FFF	
	_____	31R0000 - 31R67FF	

L/H



- **The device ranges given here show the maximum range available for each parameter setting.**
- **When using File Registers, depending on the type of unit used, a PLC Memory Card may be required. Depending on the size of the Memory Card, the device ranges will change. For details, refer to Mitsubishi Electric Co., Ltd's User's Manual.**
- **When using the QnA series unit's File Registers, depending on the QnA unit's CPU version, certain usage restrictions will apply. For details, refer to Mitsubishi Electric Co., Ltd.'s User's Manual for QnA Series.**

7.2.3 Environment Setup

■ GP Settings

The communications settings for the GP, which are required for communications via the Ethernet, as shown below:

◆ SET UP OPERATION SURROUNDINGS Menu

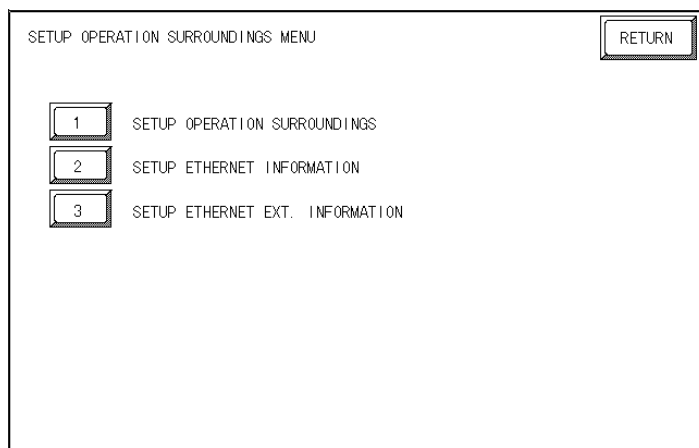

◆ SET UP ETHERNET INFORMATION

Select “SET UP ETHERNET INFORMATION,” and then enter the necessary information for each item.

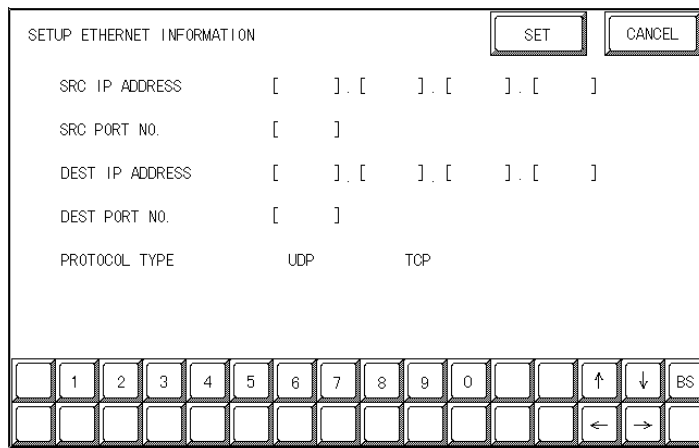

• SRC IP ADDRESS

Enter the IP address for the GP at your station. To do this, separate the 32 bits of the IP address into four segments of eight bits each, delimit those segments with a dot, and then enter them as decimal numbers.

• SRC PORT NO.

Enter your station port number in the range from 1024 to 65535.

• DEST IP ADDRESS

Enter the IP address of the other station (the MELSEC).

- **TIMEOUT (0 to 65535)**

Enter the desired timeout value. If no response is received from the other station within the specified time, a timeout occurs. If “0” is specified, the default time is 15 seconds when it is TCP communication, and is 5 seconds when it is UDP communication.

- **IP ROUTE ADDRESS**

Enter the IP address of the router (only one). If no router is used, enter “0” in all fields.

- **SUBNET MASK**

Enter subnet masks. If no subnet mask is used, enter “0” in all fields.

- **UDP RETRY COUNT (0 to 255)**

Designates the number of times the GP re-sends a command when there is no reply from the other port and a timeout occurs. When no reply is received after the re-try setting number is reached, an error message will appear on the GP screen.



If the memory is initialized in the OFFLINE mode, random values may be included. Be sure to check the displayed values.

◆ **SET UP OPERATION SURROUNDINGS**

SET UP OPERATION SURROUNDINGS												SET	CANCEL		
STARTING ADDRESS OF SYSTEM DATA AREA												[]		
SYSTEM AREA READING AREA SIZE (0-256)												[]		
DATA CODE												BINARY	ASCII		
RESET GP DATA WRITE ERROR												ON	OFF		
	1	2	3	4	5	6	7	8	9	0			↑	↓	BS
	1D	2D	3D	4D	1B	2B	3B	4B					←	→	

- **DATA CODE (Set only when connecting to a MELSEC-Q Series and MELSEC-QnA Series)**

This selection controls the type of DATA CODE settings used. Select either BINARY or ASCII, and confirm that the PLC settings are the same.

■ Sample Ladder Program

◆ MELSEC-A Series (Ethernet interface unit: AJ71E71)

PLC's Ladder Program is needed to communicate with the GP.

Reference

For the complete details of settings, refer to the user's manual for Model AJ71E71 Ethernet Interface Unit (Mitsubishi Electric).

The following is a sample ladder.

<Sample Ladder>

```
LD      M9038
DMOV P Hxxxxxxx      D100 (IP address of PLC) *1
MOV P K0      D102
MOV H0100      D116 (Settings for UDP communications)
MOV K1024      D124 (Port number of PLC)
MOV K1024      D127 (Port number of GP)
DMOV Hxxxxxxx D125 (IP address of GP) *1
DMOV HFFFFFFFF      D128
MOV HFFFF      D130
LD      M9036
TOP H0000 H0000      D100 K50
LD      X0019
MOV K5      D113
TOP H0000 K13      D113 K1
LD      M9036
OUT Y0019
LD      M9036
OUT Y0008
END
```

*1 For the IP addresses, check with the network manager. "xxxxxxx" stands for an IP address in the hexadecimal notation. Do not specify any duplicate addresses.



Be sure that any addresses (D...) used in the communications settings for the PLC are not the same as the first address of the system on the GP.

◆ MELSEC-Q Series

Prior to GP starting GP communication, the MNET/10H Ethernet settings must be set in the PLC's ladder logic software. The setting values are as shown below.

1. Network Parameter MNET/10H Ethernet Settings
2. Ethernet Operation Settings
3. OPEN Settings

1. Network Parameter MNET/10H Ethernet Settings

Items	PLC Settings
Network Classification	Ethernet
First I/O No.	Any number ^{*1}
Network No.	Any number ^{*1}
Group No.	Any number ^{*1}
Machine No.	Any number ^{*1}
Mode	Online

**1 This setting does not effect PLC/GP communication.*

2. Ethernet Operation Settings

Recommended Settings

Items	PLC Settings	
Data Code Settings	BINARY Code	ASCII Code
Initial Timing Settings	Not waiting for OPEN	Always waiting for OPEN
IP Address Settings	Any number ^{*1}	
Write Possible in RUN mode	Not allowed	Allowed ^{*2}

**1 Please contact your computer network supervisor to confirm your setting data.*

**2 When performing Write from a GP in RUN mode, set the Write Possible in RUN mode to "Allowed".*

3. OPEN Settings

Items	PLC Settings			Remarks
Protocol	TCP/IP		UDP/IP	Should be same as GP unit's Communication Format Settings.
OPEN Format ^{*1}	Active	Fullpassive	Unpassive	Either Fullpassive or Unpassive can be used.
SRC Port No.	Any number ^{*2}			Should be same as GP unit's DEST Port No.
DEST IP Address	Any number ^{*2*3}			Should be same as GP unit's SRC IP Address.
DEST Port Address	Any number ^{*2*3}			Should be same as GP unit's SRC Port No
Fixed Buffer	Transmission	Subscription		Independent of GP.
Fixed Buffer Method	Yes	No		Independent of GP.
Paring Open	Yes	No		Independent of GP.
Confirming	No	Yes		Both can be used.

**1 Can be used only when Protocol is set to TCP/IP.*

**2 Please contact your computer network supervisor to confirm your setting data.*

**3 If OPEN Format is set to "Unpassive", this item does not need to be set*

When the Auto Open UDP Port feature is used, the Table 3. OPEN Settings are not needed. When these settings are used, however, the PLC's port number is 5000 (default setting).

▼ Reference ▲ For details, refer to Mitsubishi Electric's Q and QnA Series Ethernet Interface User Manuals.

◆ MELSEC-QnA Series

PLC's Ethernet Unit Dipswitch Settings and a Ladder Program are needed to communicate with the GP.

Ethernet Unit Settings

• Operation Mode Setting Switch

Contents	Settings
Operation Mode Settings	0:Online

• Communication Condition Setting Switch

 Recommended Settings

Switch	Contents	Settings	
SW1	Action performed when TCP/IP Timeout occurs	OFF:When TCP/IP Timeout Error occurs, the line is closed.	ON:When TCP/IP Timeout Error occurs, the line is not closed.
SW2	Data Code Settings	OFF:BINARY Code	ON:ASCII Code
SW3	Auto Start Settings	OFF:Perform action(s) defined in Y19.	ON:Regardless of Y19, after unit is turned ON again or is Reset, Initialization is performed.
SW4-SW6	Cannot use (fixed to OFF)		
SW7	CPU Communication Timing Settings ^{*1}	OFF:Write in RUN mode is Impossible.	ON:Write in RUN mode is Possible.
SW8	Initial Timing Settings	OFF:Quick Start (start without time delay)	ON:Normal Start (Start after 20 seconds time delay)

**1 When performing Write From GP in RUN mode, set the CPU Communication Timing Settings to ON.*

Sample Ladder Program

This Sample Ladder Program is for communication via the Auto Open UDP Port No. (default:5000).

- PLC IP Address: 192.168.0.1
- PLC Port No.: 5000

When communicating via this function, the GP's IP Address and Port No. do not need to be set.

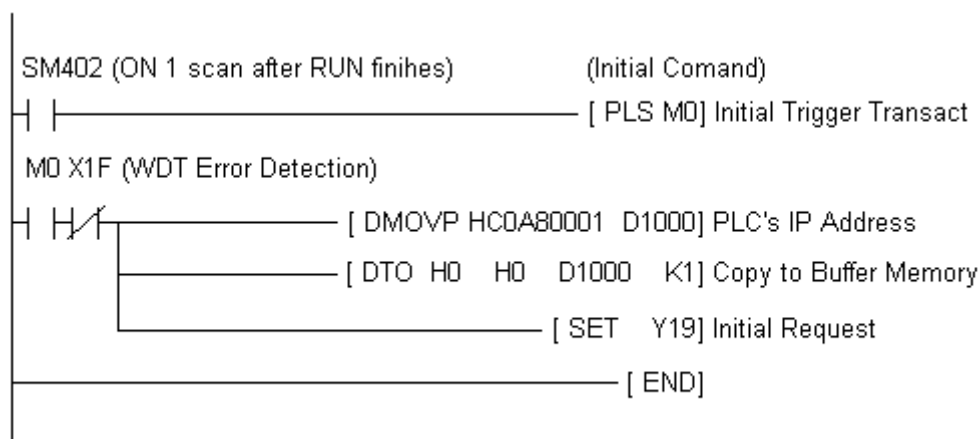

Reference

The sample ladder above is the minimum ladder to communicate with GP via UDP/IP. For details about error processing and TCP/IP communication, refer to Mitsubishi Electric Co., Ltd.'s User's manual for QnA Series Ethernet Interface Unit (Detail manual).

7.2.4 Error Code

Reference *About the GP Ethernet Specific Error Codes, refer to the end of this Chapter, "Protocol Stack Error Codes".*

■ PLC SPECIFIC ERROR CODES

PLC error codes are displayed by the “Host Communication Error (02:**:**)”, and indicated in the left lower corner of the GP screen. (**:** indicates the PLC’s specific error codes)

Error Code	Description	Status
0055	Write error in RUN mode	Write in RUN mode is set to OFF.
4031	CPU Device Settings Error	Designated device is outside allowable range.





Reference *For more details about error codes, refer to Mitsubishi Electric Co., Ltd.’s User’s Manuals for Q Series Ethernet Interface Unit and QnA Series Ethernet Interface Unit.*

7.3 TOSHIBA

7.3.1 System Structure for Ethernet Connection

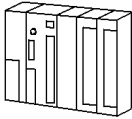
This section explains the system structure for the Ethernet connection between a PLC made by Toshiba and the GP.

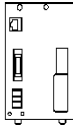
■ PROSEC T Series (using Ethernet unit)

CPU	Link I/F	Cable Diagram	Cables	Unit ^{*2}	GP/GLC
	Ethernet Unit 				
T3H	EN311		Ethernet cable (conforming to the IEEE802.3)	Digital's GP Ethernet I/F unit (GP070-ET11/GP070-ET41) GP77R Series Multi Unit E (GP077-MLTE11) GP377R Series Multi Unit (GP377-MLTE11)	GP/GLC Series *1
T2N	PU-235N PU-245N				

*1 The Ethernet-compatible GP/GLC units include the GP-470E, GP-570T, GP-570S, GP-570L, GP-570VM, GP-571T, GP-57JS, GP-675T, GP-675S, GP-477RE, GP-577RT, GP-577RS, GP377RT, GP-2400T, GP-2500T, GP-2501T, GP-2600T and GLC-2400T.

*2 Except for the GP-2501T, all GP2000 and GLC2400 Series units can also use their built-in Ethernet ports. When attaching the optional Ethernet unit to a GP2000 Series (except for the GP-2400T) unit, the optional Bus Conversion Unit (PSL-CONV00) is required. The GP-2400T and the GLC -2400T cannot use this unit.



Reference For connecting the cable, refer to “3.2 Connecting the cable” in the User’s Manual for the GP70 Series GP Ethernet Interface Unit.

7.3.2 Supported Devices

The following describes the range of devices supported by the GP.

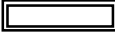
■ PROSEC T Series (T3H)

 Setup System Area here.

Device	Bit Address	Word Address	Particular	
Input Device	X0000 ~ X511F	XW000 ~ XW511	L/H	
Output Device	Y0000 ~ Y511F	YW000 ~ YW511		
Auxiliary Relay	R0000 ~ R999F	RW000 ~ RW999		
Special Relay	S0000 ~ S255F	SW000 ~ SW255		
Link Register Relay	Z0000 ~ Z999F	-		
Link Relay	L0000 ~ L255F	LW000 ~ LW255		
Timer (contact)	T000 ~ T999	-		Read only
Counter (contact)	C000 ~ C511	-		Read only
Timer (current value)	-	T000 ~ T999		
Counter (current value)	-	C000 ~ C511		
Data Register	-	D0000 ~ D8191		
Link Register	-	W0000 ~ W2047		
File Register	-	F00000 ~ F32767		





Note: The range of supported devices may be different depending on your CPU. For details, refer to Toshiba PLC's user's manual.



Important If you Write in Read Only Timer (contact) device or in Read Only Counter (contact) device, the "PLC COM. ERROR (02:10)" message will appear.

■ PROSEC T Series (T2N)

 Setup System Area here.

Device	Bit Address	Word Address	Particular	
Input Device	X0000 ~ X127F	XW000 ~ XW127		L/H
Output Device	Y0000 ~ Y127F	YW000 ~ YW127		
Auxiliary Relay	R0000 ~ R255F	RW000 ~ RW255		
Special Relay	S0000 ~ S255F	SW000 ~ SW255		
Link Register Relay	Z0000 ~ Z999F	-		
Link Relay	L0000 ~ L255F	LW000 ~ LW255		
Timer (contact)	T 000 ~ T 511	-	Read Only	
Counter (contact)	C000 ~ C511	-	Read Only	
Timer (current value)	-	T 000 ~ T 511		
Counter (current value)	-	C000 ~ C511		
Data Register	-	D0000 ~ D8191		
Link Register	-	W0000 ~ W2047		
File Register	-	F0000 ~ F1023		



If you Write in Read Only Timer (contact) device or in Read Only Counter (contact) device, the “PLC COM. ERROR (02:10)” message will appear.

7.3.3 Environment Setup

■ GP Unit Setup

The following describes GP settings for using Ethernet communication.

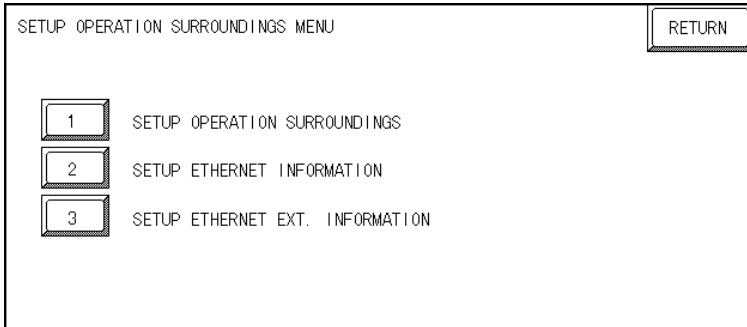

Set the station No. to "0" for [1] SET UP OPERATION SURROUNDINGS.

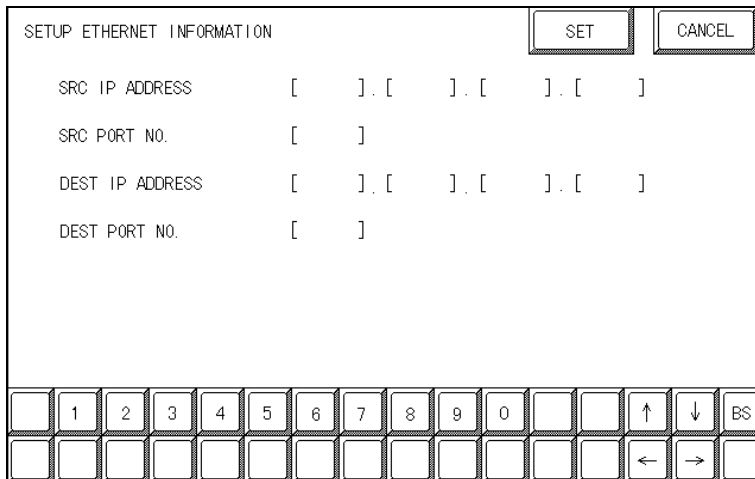

Select "SETUP ETHERNET INFORMATION" and set up the Addresses and Port Numbers.

• SRC IP ADDRESS

Enter GP's SRC IP Address. Input a dot between every 8 bits to divide the IP Address (32 bits all together) into four groups, and enter decimal numbers in each groups.

• SRC PORT NO.

Set the SRC Port No. between 1024 and 65535.

• DEST IP ADDRESS

Set the PROSEC's DST IP Address.

• DEST PORT NO.

Set the DEST Port No. between 1024 and 65535.



The communication method is UDP format.



When using the built-in Ethernet port on a GP2000 or GLC2000 series unit, be sure not to set any duplicate "SRC PORT No." values.

Check the 2-way driver's "SRC PORT No." setting via the following menu:

GP OFFLINE mode's Main menu [INITIALIZE] -> [SETUP OPERATION SURROUNDINGS] -> [EXTENDED SETTINGS] -> [SETUP ETHERNET INFORMATION].

The default value is 8000. The 2-way driver uses this port and the following 9 ports.



Regarding the IP Address and the Port No., please confirm these points with your Network supervisor. You must not duplicate the number you have already used for an IP Address setting.

SETUP ETHERNET EXT. INFORMATION												SET	CANCEL	
SEND WAIT TIME	[]	(ms)										
TIMEOUT	[]	(x 2sec)										
IP ROUTER ADDRESS	[]	.	[]	.	[]	.	[
SUBNET MASK	[]	.	[]	.	[]	.	[
UDP RETRY COUNT (0 to 255)	[]											

	1	2	3	4	5	6	7	8	9	0		↑	↓	BS
												←	→	

SEND WAIT TIME

You can display the waiting time while GP's command is actually sent. This function is useful when there is a lot of traffic in your system. If not using, set it to "0".

TIMEOUT

You can set time for waiting for a replay from the destination. If any replay is not made by the destination within time you set to, the communication will be timeout. "0" setting is the default value as 15 second-setting for timeout.

IP ROUTER ADDRESS

Set Router's IP Address. (There is only one setting for Router.) If not using, set all values to "0".

SUBNET MASK

Set the Subnet Mask . If not using, set all values to "0".

UDP RETRY COUNT (0 to 255)



- *If you initialize the memory from the OFFLINE mode, some values might be automatically set to the factory settings. Please confirm all values after initialization.*
- *Refer to the PLC's users manual for PLC settings.*
- *Set the Ethernet module to the RUN mode after you have set the IP Address and the Port No.*

■ Sample Ladder Program

The following is the Sample Program shown in the Toshiba's Ethernet Module Users Manual.

◆ IP Address \ Port No. settings

```

| R0502                                     R0602 |
1 |---||----- ( )-----|
|                                     /* Parameter setting request */
| R0602
2 |---||-----+[12544 MOV RW000 ] [00018 MOV RW001 ]-----|
|                                     /* Set Module and CMD No.*/
|                                     |
|                                     +[**** MOV RW002] [**** MOV RW003] [**** MOV RW004]-----|
|                                     /* Set IP Address and Port No.*/
|                                     |
|                                     +[RW000 SEND RW010] [RST R0502]-----|
|                                     /* Set Request */
|

```



Please contact your computer network supervisor to confirm your IP Address and Port No.

◆ Operation Mode control

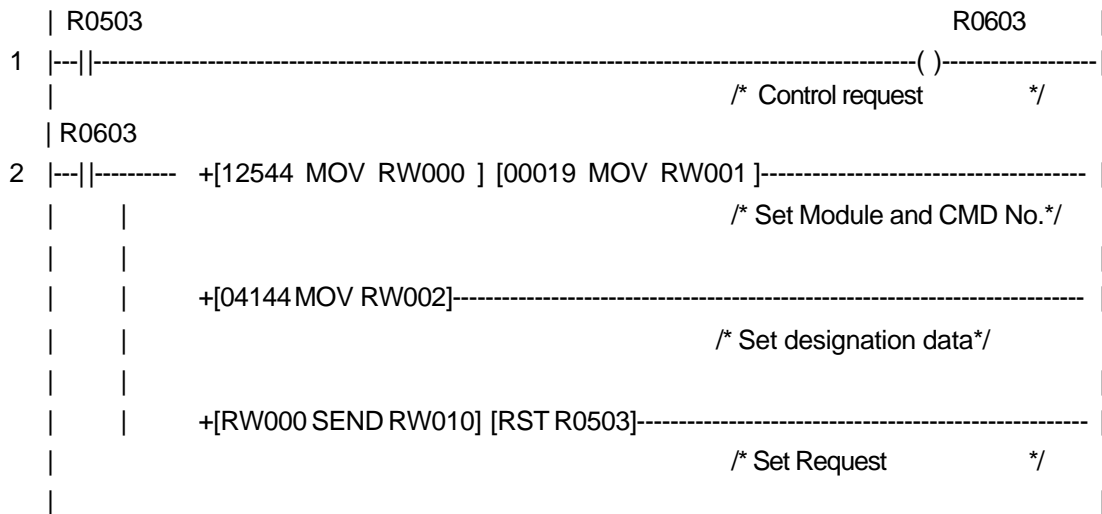

After setting an IP Address, you need to switch the system to LINE Mode.





7.4 Yokogawa Electric

7.4.1 System Structure for Ethernet Connection

This section explains the system structure for the Ethernet connection between a PLC made by Yokogawa Electric Corp. and the GP.

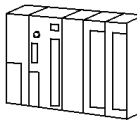
■ FACTORY ACE Series/FA-M3 (Using Ethernet Unit)

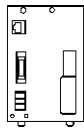
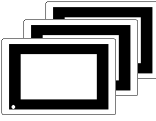
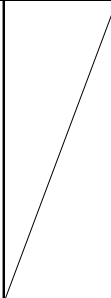
CPU	Link I/F	Cable Diagram	Cable	Unit ^{*2}	GP/GLC
	Ethernet Unit 				
F3SP20-0N F3SP21-0N F3SP25-2N F3SP30-0N F3SP35-0N F3SP28-3N F3SP38-6N F3SP53-4H F3SP58-6H	F3LE01-5T		Ethernet Cable IEEE802.3 standard	Digital's GP Ethernet I/F unit (GP070-ET11/GP070-ET41) GP77R Series Multi Unit E (GP077-MLTE11) GP-377R Series Multi Unit (GP377-MLTE11)	GP/GLC Series *1

*1 The Ethernet-compatible GP/GLC units include the GP-470E, GP-570T, GP-570S, GP-570L, GP-570VM, GP-571T, GP-57JS, GP-675T, GP-675S, GP-477RE, GP-577RT, GP-577RS, GP377RT, GP-2400T, GP-2500T, GP-2501T, GP-2600T and GLC-2400T .

*2 Except for the GP-2501T, all GP2000 and GLC2400 Series units can also use their built-in Ethernet ports. When attaching the optional Ethernet unit to a GP2000 Series (except for the GP-2400T) unit, the optional Bus Conversion Unit (PSL-CONV00) is required. The GP-2400T and the GLC -2400T cannot use this unit.

Reference When connecting the Ethernet cable, refer to the **GP70 series GP Ethernet Interface Unit User's Manual**, "Chapter 3.2 Connecting the cable".

7.4.2 Supported Devices

The following list shows the range of devices supported by the GP.

FA-M3 Series

 Setup System Area here.

Device	Bit Address	Word Address	Particulars
Input Relay	X00201 ~ X71664	X00201 ~ X71649	$\div 16 + 1$ *1*2
Output Relay	Y00201 ~ Y71664	Y00201 ~ Y71649	$\div 16 + 1$ *1
Internal Relay	I00001 ~ I32768	I00001 ~ I32753	$\div 16 + 1$
Joint Relay	E0001 ~ E4096	E0001 ~ E4081	$\div 16 + 1$
Special Relay	M0001 ~ M9984	M0001 ~ M9969	$\div 16 + 1$
Link Relay	L00001 ~ L78192	L00001 ~ L78177	$\div 16 + 1$
Timer (contact)	T0001 ~ T3072	---	
Counter (contact)	C0001 ~ C3072	---	
Timer (current value)	---	TP0001 ~ TP3072	
Timer (setup value)	---	TS0001 ~ TS3072	*2
Counter (current value)	---	CP0001 ~ CP3072	
Counter (setup value)	---	CS0001 ~ CS3072	*2
Data Register	---	D0001 ~ D32768	Bit 5
File Register	---	B00001 ~ B065536	Bit 5 *3
		B065537 ~ B131072	
		B131073 ~ B196608	
		B196609 ~ B262144	
Joint Register	---	R0001 ~ R4096	Bit 5
Special Register	---	Z001 ~ Z1024	Bit 5
Link Register	---	W00001 ~ W74096	Bit 5 *4

L/H

*1 The value of the terminal number (bit), 01~49, of the last two digits for the Input Relay and

Output Relay can only be a multiple of 16 + 1.

E.g. For X00201

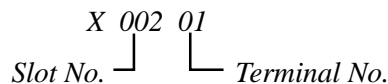

*2 Cannot perform data write.

(Continued on next page)

7.4.3 Environment Setup

■ GP Settings

The GP's required Ethernet communication settings are shown below.

◆ **SETUP OPERATION SURROUNDINGS MENU**

DATA CODE

This selection controls the date code settings. Select either BINARY or ASCII. Be sure this value is the same as the current PLC setting.

◆ **SETUP ETHERNET INFORMATION**

Select "SET UP ETHERNET INFORMATION," from the above screen and enter the necessary information for each item shown below.

SRC IP ADDRESS

Enter the IP address for your GP here. The IP address 32 bits are separated into four segments of eight bits each, delimited with a dot. All are decimal numbers.

SRC PORT NO.

Enter your station's port number here, from 1024 to 65535.

DEST IP ADDRESS

Enter the IP address of the other station (PLC).

DEST PORT NO.

Enter the port number for the other station. In this case, 12289.

PROTOCOL TYPE

You can select either UDP or TCP communication. If the power will be turned ON/OFF asynchronously, it is recommended that you use UDP communications.



Do not specify duplicate IP addresses. Contact the network manager about IP addresses.



When using the built-in Ethernet port on a GP2000 or GLC2000 series unit, be sure not to set any duplicate "SRC PORT No." values.

Check the 2-way driver's "SRC PORT No." setting via the following menu:

GP OFFLINE mode's Main menu [INITIALIZE] -> [SETUP OPERATION SURROUNDINGS] -> [EXTENDED SETTINGS] -> [SETUP ETHERNET INFORMATION].

The default value is 8000. The 2-way driver uses this port and the following 9 ports.

- **SET UP ETHERNET EXT. INFORMATION**

SETUP ETHERNET EXT. INFORMATION												SET	CANCEL		
SEND WAIT TIME	[]	(ms)											
TIMEOUT	[]	(x 2sec)											
IP ROUTER ADDRESS	[].	[].	[].	[
SUBNET MASK	[].	[].	[].	[
UDP RETRY COUNT(0-255)	[]												
		1	2	3	4	5	6	7	8	9	0		↑	↓	BS
													←	→	

SEND WAIT TIME (0 to 255)

Wait time can be added when a command is transmitted from the GP. Use the wait time if the traffic on the communications line is heavy. If no wait time is required, enter “0.”

TIMEOUT (0 to 65535)

Enter the desired timeout value. If no response is received from the other station within the specified time, a timeout occurs. If “0” is specified, the default time is 15 seconds when using TCP, and 5 seconds when using UDP.

IP ROUTER ADDRESS

Enter the IP address of the router (one only). If no router is used, enter a “0” in each of the four fields.

SUBNET MASK

Enter the subnet mask data. If no subnet mask is used, enter a “0” in each of the four fields.

UDP RETRY COUNT (0 to 255)

Designates the number of times the GP re-sends a command when there is no reply from the other port and a timeout occurs. When no reply is received after the re-try setting number is reached, an error message will appear on the GP screen.



If the GP's memory is initialized in OFFLINE mode, random values may appear in these settings. Be sure to check all displayed values after performing initialization.

■ PLC Settings

The PLC's required Ethernet communication settings are shown below. Designate the setting via the Ethernet module's side face switch.

PLC Settings	
Data Code Switch	ON (Binary)/OFF (ASCII)
Write Protect	OFF (Not Protected)
TCP Timeout	OFF (Close)
Run Mode	OFF (RUN)
IP Address	Set via Rotary Switch







7.5 Omron

7.5.1 System Structure for Ethernet Connection

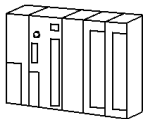
This section explains the system structures for the Ethernet connection between OMRON PLCs and GP units.

■SYSMAC CS1 Series

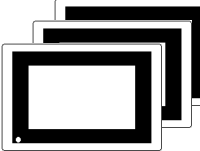
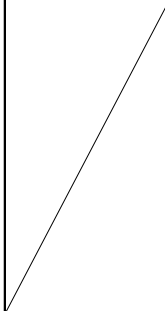
CPU	Link/I/F	Cable Diagram	Cables	Unit ^{*2}	GP
	 Ethernet Unit				
CS1H-CPU67 CS1H-CPU66 CS1H-CPU65 CS1H-CPU64 CS1H-CPU63 CS1G-CPU45 CS1G-CPU44 CS1G-CPU43 CS1G-CPU42	CS1W-ETN01		Ethernet cable (compatible with the IEEE802.3)	Pro-face Ethernet I/F Unit GP070-ET11 GP070-ET41 GP377-MLTE11 GP377-MLTE41 GP077-MLTE41	GP Series ^{*1}

**1 The Ethernet-compatible GP units include the GP-377RT, GP-477RE, GP-577RT, GP-577RS, GP-2400T, GP-2500T, GP-2501T and GP-2600T.*

**2 Pro-face's GP-2500T, GP-2600T units can also use their built-in Ethernet ports. GP-2400T units can use only their built-in Ethernet ports.*

Reference For connecting cables, refer to the User Manual for each Option Unit. When using GP2000 Series units, refer to the GP2000 Series User Manuals.



Careful! Do not to connect this Ethernet network with Pro-Server.

◆ System Design

Ex.) 1 : n connection

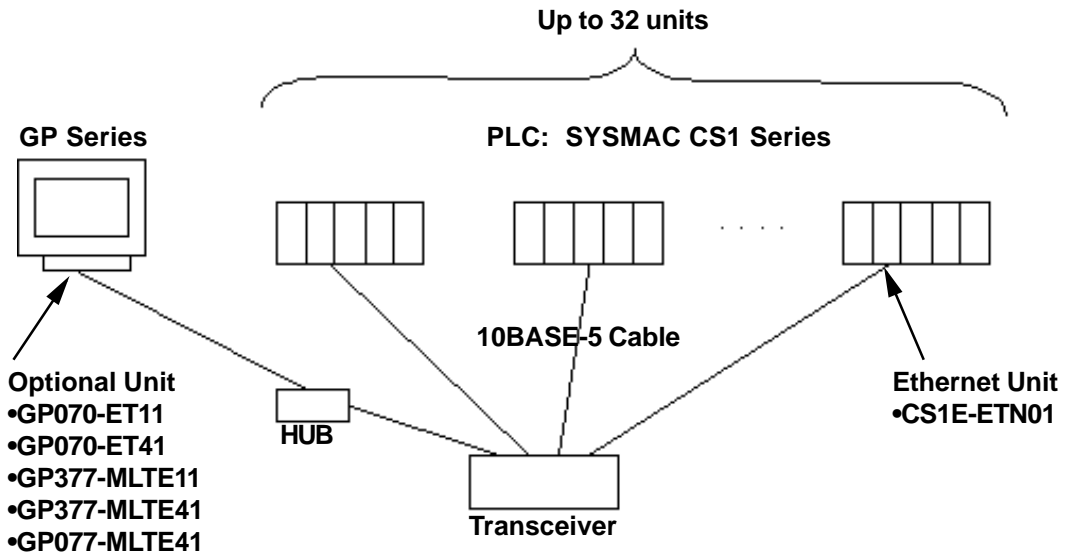

Ex.) n:1 connection

n units (While there is no limitation to the number of units connected, as the number increases, the communication load will also increase, which can lead to slower communication.)

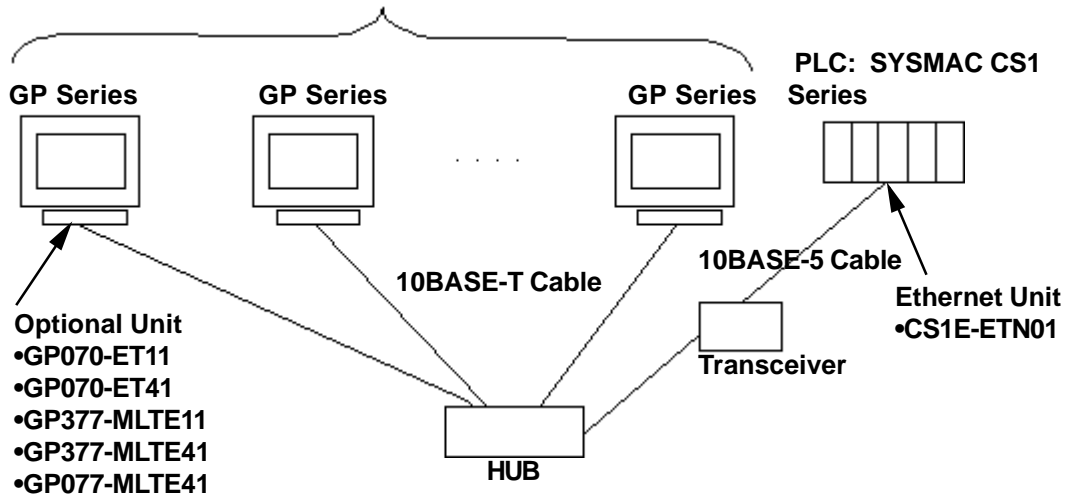

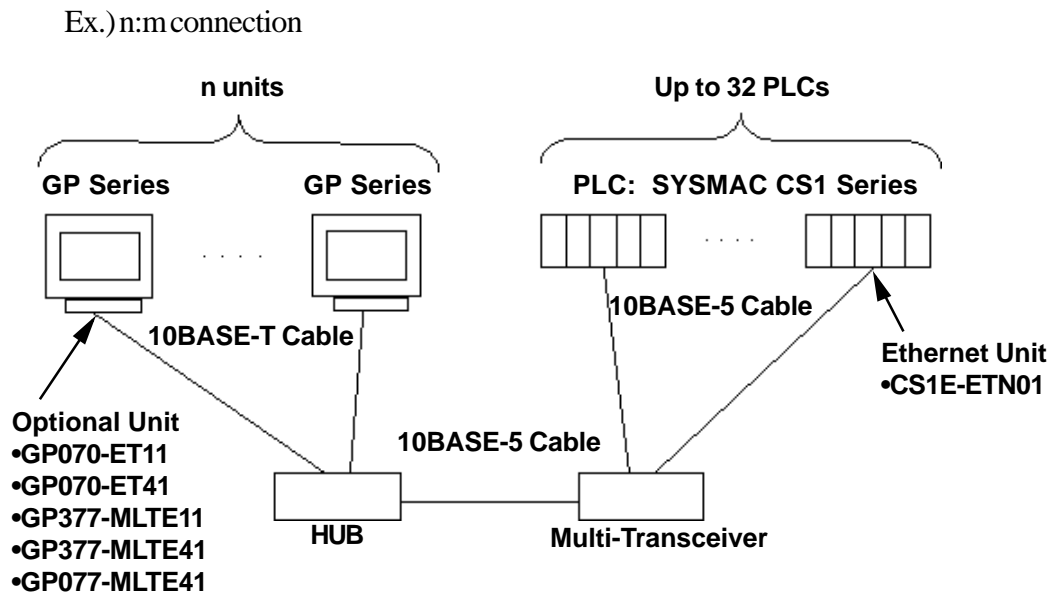

◆ Network Design

- When the GP and the target PLC use the same network address.

GP Settings

IP Address : 192.168.0.1
 FINS UDP Port No. : 9600
 Network Address : 1
 Node Address : 50

PLC Settings

IP Address : 192.168.0.2
 FINS UDP Port No. : 9600
 Network Address : 1
 Node Address : 100

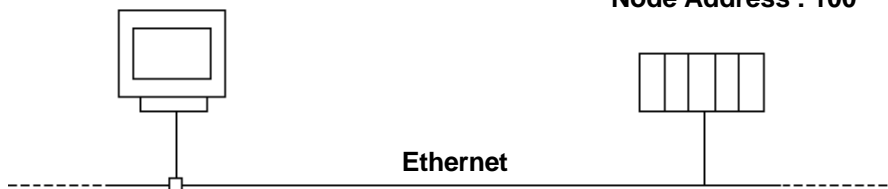

GP to PLC Setting Information

Destination Node IP Address : 192.168.0.2
 FINS UDP Port No. : 9600 (Default)
 Network Address : 1
 Node Address : 100

- When there is a junction PLC used between the GP and target PLC.

GP Settings

IP Address : 192.168.0.1
 FINS UDP Port No. : 9600
 Network Address : 1
 Node Address : 50

Junction PLC Settings

IP Address : 192.168.0.2
 FINS UDP Port No. : 9600

PLC Settings

Network Address : 2
 Node Address : 1

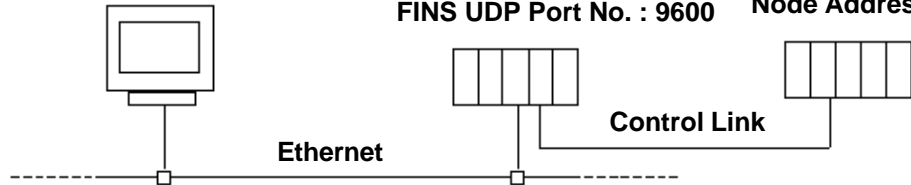
**GP to PLC Setting Information**

Destination IP Address : 192.168.0.2 (IP Address for Junction PLC)
 FINS UDP Port No. : 9600 (Default) (Port No. for Junction PLC)
 Destination Network Address : 2
 Destination Node Address : 1

7.5.2 Supported Devices

The following list shows the range of devices supported by the GP.

■ SYSMAC CS1 Series

 Setup System Area here.

Device	Bit Address	Word Address	Other	
Channel I/O	CIO000000 ~ CIO614315	CIO0000 ~ CIO6143		*2
Internal Auxiliary Relay	W00000 ~ W51115	W000 ~ W511		
Hold Relay	H00000 ~ H51115	H000 ~ H511		
Special Auxiliary Relay	A00000 ~ A95915	A000 ~ A959		*1
Timer (Contact)	T0000 ~ T4095	_____		*3
Counter (Contact)	C0000 ~ C4095	_____		*3
Timer (Current)	_____	T0000 ~ T4095		
Counter (Current)	_____	C0000 ~ C4095		
Data Memory	D0000000 ~ D3276715	D00000 ~ D32767		*2
Expansion Data Memory (E0 ~ EC)	E00000000 ~ EC3276715	E000000 ~ EC32767		*4
Expansion Data Memory (Current Bank)	_____	EM00000 ~ EM32767	Bit 5	
Task Flag	_____	TK0 ~ TK30	÷2 Bit 5	*3
Index Register	_____	IR0 ~ IR15	Bit 3	*3
Data Register	_____	DR0 ~ DR15	Bit 5	*3

L/H

*1 Addresses A00 to A477 cannot be written to.

*2 When using the Ethernet Unit (CS1W-ETN01), be sure not to perform Write from a GP to Data Memory D30000 to D31599 or from Channel I/O CIO1500 to CIO1899 since these addresses are used for the PLC's setting ranges.

Reference For details, refer to the OMRON SYSMAC CS1 Series CS1W-ETN01 CS1W-ETN11 Ethernet Units OPERATION MANUAL.

*3 Cannot be written to.

*4 The Expansion Data Memory ranges available will vary depending on the type of CPU used.

◆ Device Address and Node Number Limitations

Even though the CS1 Ethernet Protocol can access more than one CPU, the following limitations apply.

• Limitations

When a device address's size is larger than 1024 (1K) or a different network and node addresses is set, the number of available device addresses will vary. The GP uses internal records are used to set the device addresses. There records are limited to 64. For example, when the D0 device address is set, a single record is used in the GP. For detailed examples, refer to the following chart.

Ex1.) Number of records used when designatng tag setting numbers.

Setting No.	NetWork Address	Node Address	Device Address	Remaining Number of records in GP-PRO/PBIII	Other
1	1	1	D0	63	Uses one record
2	1	1	D1024	62	Uses one record
3	2	1	D0	61	Uses one record
4	2	1	D1024	60	Uses one record
5	2	1	T0	60	Since the node number and address range already exist as setting No.3, no records will be used.
6	2	1	T1024	60	Since the node number and address range already exist as setting No.4, no records will be used.
7	2	1	D2048	59	Uses one record
8	2	2	D2048	58	Uses one record
9	3	1	D2048	57	Uses one record
10	3	1	D2049	57	Since the node number and address range already exist as setting No.9, no records will be used.

When the total number of Network Addresses, Node Addresses and Device Addresses are exceeds 1024, GP internal records are used. However, if the Network Address, Node Address and Device Address are the same type, no record will be used, even if the device types are different.

Ex2.) When setting tags from D00000 to D16384 in Data Memory, since one record is used for every 1024 addresses, a total of 16 records will be used.

$$16384/1024=16$$

Therefore, when setting the same number of tags for each node, settings for only a total of only four nodes can be set.

$$64/16=4$$



Note: When the number of records is over 65, the following error message will appear on the GP Screen Editor software (GP-PRO/PBIII for Windows).

“Address entry limit reached. No more can be entried”

◆ **When setting parts or tags from GP Screen Editor (GP-PRO/PBIII for Windows)**

Before setting parts or tags, Network Information settings must be entered. Network Information Setting can be set from the [GP SYSTEM SETTING]->[MODE SETTIN]->[Network Information] screen.

Reference this manual, 7.5.3 Environment Setup

Specifying the PLC's Network Address and Node Address when setting parts or tags, allows the specified PLC's Device to be read out.

Setting Example

When the Destination Network Address is 1 and Node Address is 1, "1" for the Network Address and "1" for the Node Address.

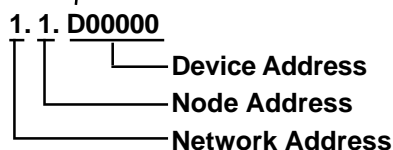
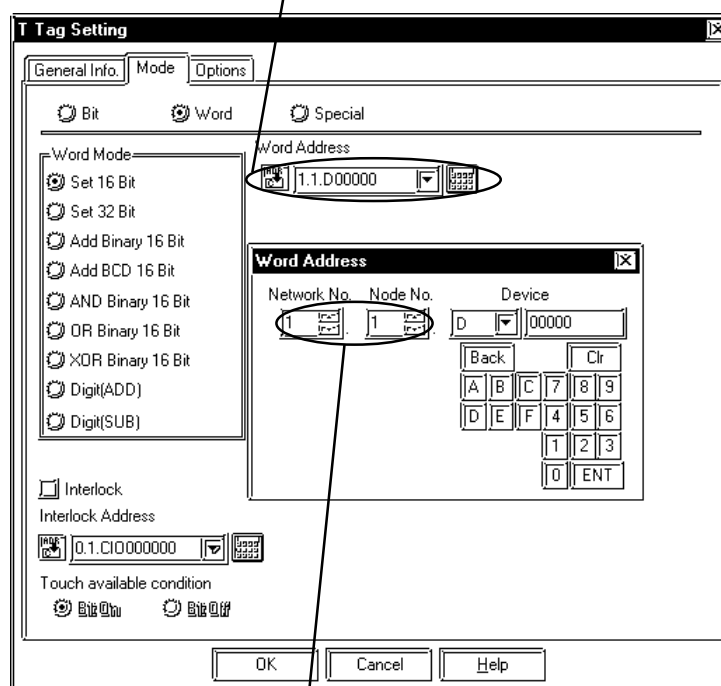

Note: In case of setting parts or tags from GP Screen Editor (GP-PRO/PBIII for Windows), PLC's Network Address and Node Address can be set when inputting the address. When the Network Address or Node Address are not specified, the previously entered numbers are kept. When entering new setup values, the default values are:

Network Address : 0

Node Address : 1

7.5.3 Environment Setup

■GP Settings

The following screens show the GP's communication settings, which are required for communications via the Ethernet connection:

◆SET UP OPERATION SURROUNDINGS MENU

<GP-477R Series, GP-577R Series, GP2000 Series>

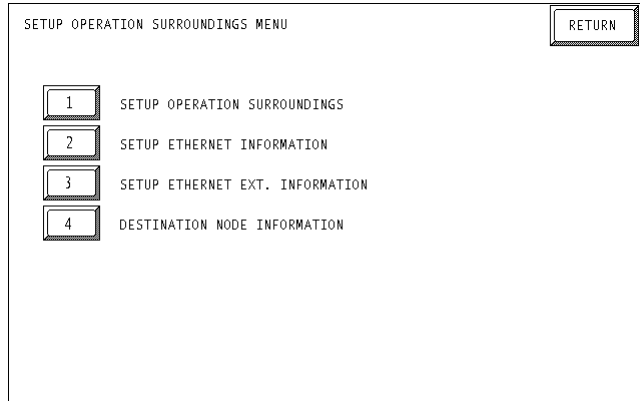

<GP-377R Series>

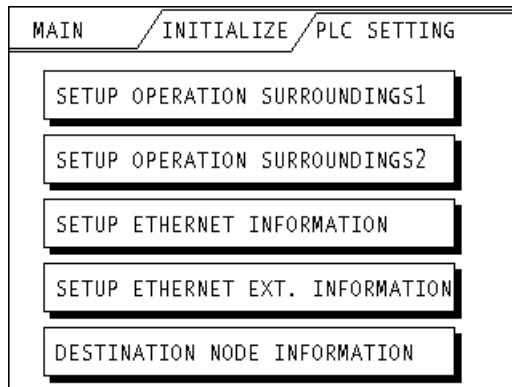

• SET UP OPERATION SURROUNDINGS

<GP-477R Series, GP-577R Series, GP2000 Series>

SETUP OPERATION SURROUNDINGS		SET	CANCEL
STARTING ADDRESS OF SYSTEM DATA AREA	[D]		
DESTINATION NETWORK ADDRESS	[]		
DESTINATION NODE ADDRESS	[]		
SYSTEM AREA READING AREA SIZE (0-256)	[]		
RESET GP ON DATA WRITE ERROR	ON OFF		
<p>Note! The system start address, network address and node address cannot be change on GP. Please use GP-PRO/PB3 to set this data and re-send to the GP.</p>			
1	2	3	4
5	6	7	8
9	0	↑	↓
		BS	
		←	→

<GP-377R Series>

SETUP OPERATION SURROUNDINGS1		SET	ESC
SYSTEM AREA START ADR D			
DEST NETWORK ADR			
DEST NODE ADR			
Please use GP-PRO/PB3 to modify the address for system, network and node.			

SETUP OPERATION SURROUNDINGS2		SET	ESC
SYSTEM AREA READ SIZE			
RESET GP ON WRITE ERROR			



Be sure the Destination Network Address and Destination Node Address entered are the same as the PLC's settings. However, the Destination Network Address and Destination Node Address settings cannot be changed from the GP's OFFLINE mode. Be sure to make these settings from the GP Screen Editor's [GP SYSTEM SETUP] -> [MODE SETUP] setting area..



This manual, 7.5.3 Environment Setup ■GP Screen Editor software (GP-PRO/PBIII for Windows) Settings

◆ SETUP ETHERNET INFORMATION

Enter each item in the SET UP ETHERNET INFORMATION screen.

<GP-477R Series, GP-577R Series, GP2000 Series>

SETUP ETHERNET INFORMATION												SET	CANCEL	
SRC IP ADDRESS	[]	.	[]	.	[]	.	[]			
SRC NETWORK ADDRESS	[]												
SRC NODE ADDRESS	[]												
FINS UDP PORT NO.	[]												
	1	2	3	4	5	6	7	8	9	0		↑	↓	BS
												←	→	

<GP-377R Series>

SETUP NETWORK INFORMATION												SET	ESC	
SRC IP ADD.	[]	.	[]	.	[]	.	[]			
SRC NETWORK ADDRESS														
SRC NODE ADDRESS														
FINS UDP PORT NO.														

- **SRC IP ADDRESS**

Enter the IP address for the GP at your satation. To do this, separate the 32 bits of the IP address into four segments of eight bits each, delimit those segments with a dot, and then enter them as decimal numbers.

- **SRC NETWORK ADDRESS (0 to 127)**

Enter your GP's Network address.

- **SRC NODE ADDRESS (0 to 126)**

Enter your GP's Node address.

- **FINS UDP PORT NO. (1024 to 65535)**

Enter the FINS UDP port number, between 1024 and 65535. Set the port number so that it is the same as the PLC's FINS UDP port number. The PLC's default value is 9600. When connecting one PLC with more than one GP unit, all GP FINS UDP port numbers need to be set as the same values.



Do not specify duplicate IP addresses. Contact your network manager about assigning IP addresses.



- When using the built-in Ethernet port on a GP2000 Series unit, be sure not to enter duplicate "SRC PORT No." values.

Check the 2-way driver's "SRC PORT No." Setting via the following menu:

GP OFFLINE mode's Main menu [INITIALIZE] -> [SETUP OPERATION SURROUNDINGS] -> [EXTENDED SETTINGS] -> [SETUP ETHERNET INFORMATION] screen.

The default value is 8000. The 2-way driver uses this port and the following nine ports for a total of 10 (8000 ~ 8009).

◆SET UP NETWORK EXT. INFORMATION

<GP-477R Series, GP-577R Series, GP2000 Series>

SETUP ETHERNET EXT. INFORMATION												SET	CANCEL
SEND WAIT TIME	[]	(ms)										
TIMEOUT	[]	(x 2sec)										
IP ROUTER ADDRESS	[]	.	[]	.	[]	.	[]		
SUBNET MASK	[]	.	[]	.	[]	.	[]		
UDP RETRY COUNT(0-255)	[]											
	1	2	3	4	5	6	7	8	9	0	↑	↓	BS
											←	→	

<GP-377R Series>

SETUP NETWORK EXT. INFORMATION												SET	ESC
SEND WAIT TIME			(ms)										
TIMEOUT			(x 2sec)										
IP ROUTER ADD.	[]	.	[]	.	[]	.	[]		
SUBNET MASK	[]	.	[]	.	[]	.	[]		
UDP RETRY COUNT(0-255)													

- **SEND WAIT TIME (0 to 255)**

Wait time can be added when a command is transmitted from the GP. Use the wait time if the traffic on the communications line is heavy. If no wait time is required, enter "0."

- **TIMEOUT (0 to 65535)**

Enter the desired timeout value. If no response is received from the other station within the specified time, a timeout occurs. If "0" is specified, the default time is 5 seconds with UDP/IP communication.

- **IP ROUTER ADDRESS**

Enter the IP address of the router (only one). If no router is used, enter "0" in all fields.

- **SUBNET MASK**

Enter the subnet mask settings. If no subnet mask is used, enter "0" in all fields.

- **UDP RETRY COUNT (0 to 255)**

Designates the number of times the GP re-sends a command when there is no reply from the other port and a timeout occurs. When no reply is received after the retry setting number is reached, an error message will appear on the GP screen.



- ***If GP memory is initialized in OFFLINE mode, random values may be included. Download the GP System Setting from GP-PRO/PBIII for Windows.***

• **DESTINATION NODE INFORMATION**

<GP-477R Series, GP-577R Series, GP2000 Series>

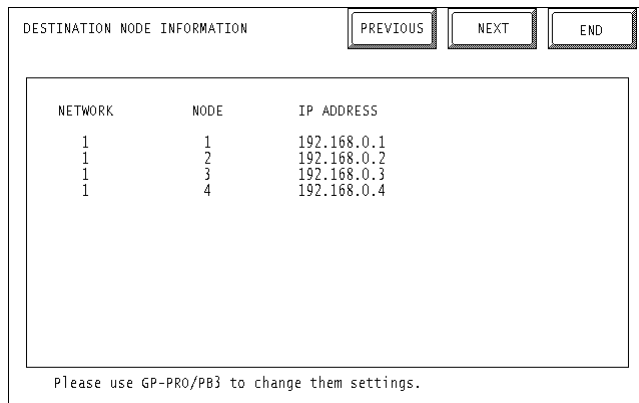

<GP-377R Series>

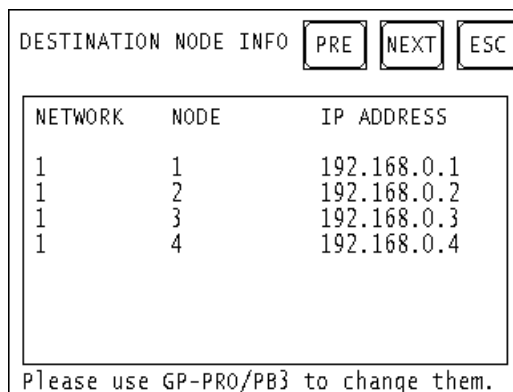

• **DESTINATION NODE INFORMATION**

The Destination (PLC) Network Address, Destination Node Address and IP Address are displayed here. Press [NEXT] button to see the next page.



The DESTINATION NODE INFORMATION cannot be set or changed from the OFFLINE mode. Set or change these values from the GP Screen Editor software (GP-PRO/PBIII for Windows) [GP SYSTEM SETTINGS]-> [MODE SETTINGS] -> [NETWORK INFORMATION SETTINGS].



This manual, 7.5.3 Environment Setup ■GP Screen Editor software (GP-PRO/PBIII for Windows) Settings

■GP Screen Editor software (GP-PRO/PBIII for Windows) settings

The following items can be entered from the GP Screen Editor software (GP-PRO/PBIII for Windows) [GP SYSTEM SETTINGS] -> [MODE SETTING] area.

Menu	Sub Menu	Item
Communication Settings	_____	SRC IP ADDRESS
		FINS UDP PORT NO.
	Advanced Communication Settings	SEND WAIT TIME
		TIME OUT
		IP ROUTER ADDRESS
Mode Settings	_____	SUBNET MASK
		SYSTEM START ADDRESS
	Network Information Settings	READ AREA SIZE
		NETWORK ADDRESS
		NODE ADDRESS
		DESTINATION NETWORK ADDRESS
		DESTINATION NODE ADDRESS
DESTINATION IP ADDRESS		

◆COMMUNICATION SETTINGS

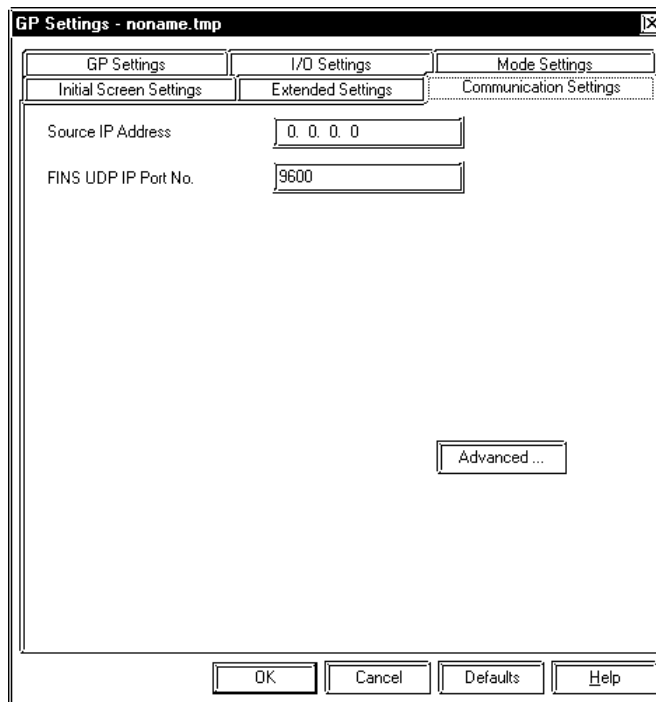

• SRC IP ADDRESS

Enter the IP address for the GP at your station. To do this, separate the 32 bits of the IP address into four segments of eight bits each, delimit those segments with a dot, and then enter them as decimal numbers.

• FINS UDP PORT NO. (1024 ~ 65535)

Enter the FINS UDP port number, between 1024 and 65535. Set the port number so that it is the same as the PLC's FINS UDP port number. The PLC's default value is 9600. When connecting one PLC with more than one GP unit, all GP FINS UDP port numbers need to be set as the same values.

•ADVANCED COMMUNICATION SETTINGS

The screenshot shows a dialog box titled "Advanced Communication Setup". It contains the following fields and values:

- Send Wait Time: 0 msec
- Time Out: 0 x2 sec
- IP Router Address: 0. 0. 0. 0
- Subnet Mask: 0. 0. 0. 0
- UDP Retry Count: 2

Buttons on the right: OK, Cancel, Help.

• SEND WAIT TIME (0 to 255)

Wait time can be added when a command is transmitted from the GP. Use the wait time if the traffic on the communications line is heavy. If no wait time is required, enter "0."

• TIMEOUT (0 to 65535)

Enter the desired timeout value. If no response is received from the other station within the specified time, a timeout occurs. If "0" is specified, the default time is 5 seconds with UDP/IP communication.

• IP ROUTER ADDRESS

Enter the IP address of the router (only one). If no router is used, enter "0" in all fields.

• SUBNET MASK

Enter the subnet mask settings. If no subnet mask is used, enter "0" in all fields.

• UDP RETRY COUNT (0 to 255)

Designates the number of times the GP re-sends a command when there is no reply from the other port and a timeout occurs. When no reply is received after the retry setting number is reached, an error message will appear on the GP screen.

◆MODE SETTINGS

•SYSTEM START ADDRESS SETTINGS

System Start Address Settings are as shown below. The System Area and Read Area are assigned to the PLC node designated here.

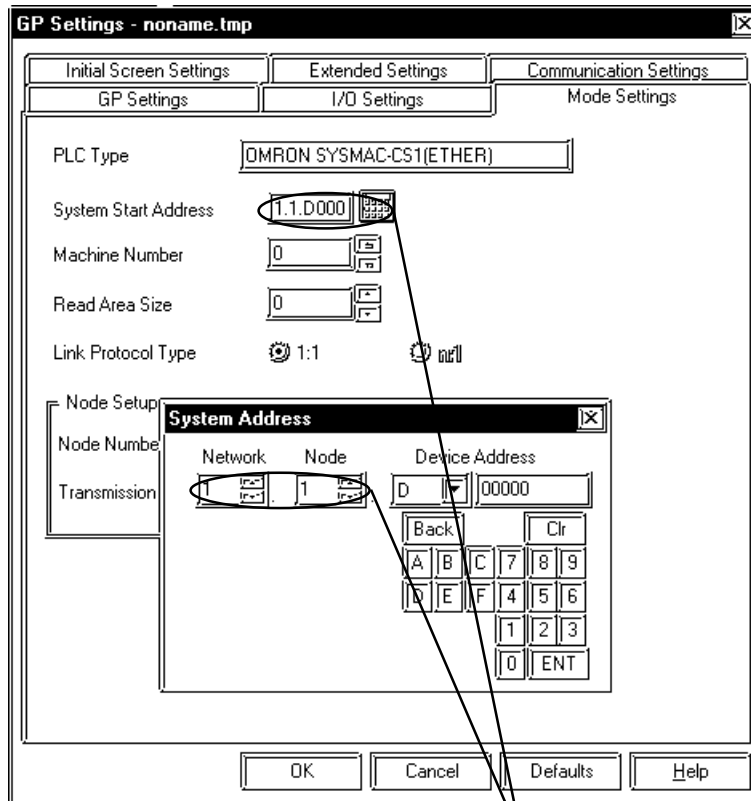

The System Start Address is allocated to the PLC node entered here. Set the Network Address and Node Address to the same address values as set in the Destination Node Information. (Set in the [MODE SETTINGS] -> [NETWORK SETTINGS].).

•NETWORK INFORMATION SETTINGS

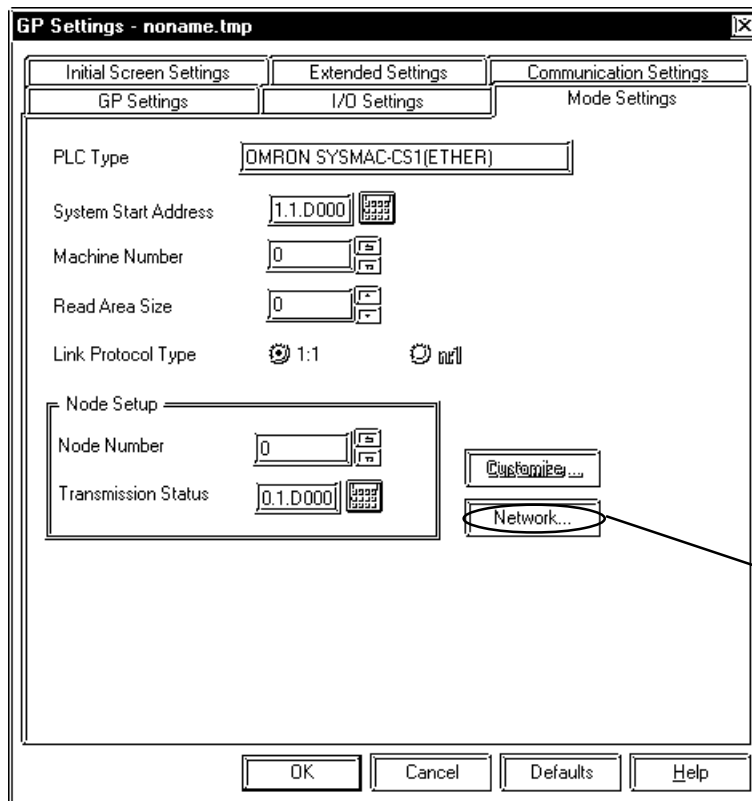

Click on this button to set the Network Information.

The Source Node Info and Destination Node Info are set as shown below.

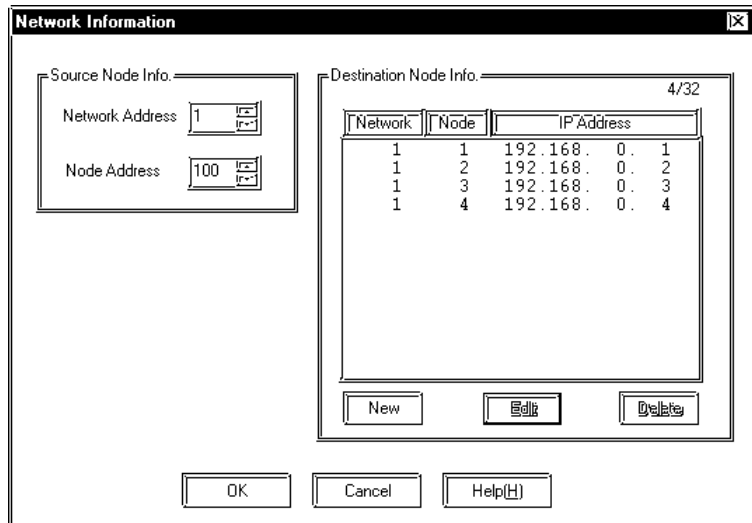

The Source Node Info can be entered by clicking on that item directly.

• SOURCE NODE INFO.

Enter your GP's Network Address and Node Address.

When entering Destination Node Information Settings, click on New or Edit button and the dialog box shown below appears.

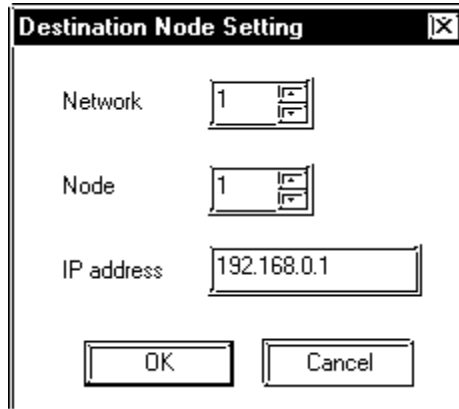

The image shows a dialog box titled "Destination Node Setting" with a close button (X) in the top right corner. It contains three input fields: "Network" with the value "1", "Node" with the value "1", and "IP address" with the value "192.168.0.1". Below the input fields are two buttons: "OK" and "Cancel".

- **DESTINATION NODE SETTING**

Enter the destination PLC Node number. The Maximum number of Nodes is 32. The Destination PLC Node IP Address needs to be set to the same address as the target PLC or the junction PLC's IP address. The Destination Network Address and Destination Node Address need to be set to the target PLC's addresses.

■ **PLC SETTINGS**

◆ **SYSMAC CS1 Series**

Item	GP Settings		PLC Settings	
SRC IP Address	SRC IP Address	GP's Address *1	IP Address Setting Switch	PLC's Address
SRC Node Address	SRC Node Address	GP's Address	Node No. Switch	PLC's No.
SRC Network Address	SRC Network Address	GP's Address	Network Address	PLC's Address
Destination IP Address	Destination IP Address	Target or transit PLC's IP Address	IP Address Table	GP's IP Address
Destination Node Address	Destination Node Address	Target or transit PLC's Node Address	IP Address Table	GP's Node Address
Destination Network Address	Destination Network Address	Target or transit PLC's Network Address	_____	_____
Port No. *2	FINS UDP Port No.	9600	FINS UDP Port No.	9600

*1 Contact your network administrator about setting values.

*2 PLC's default Port number is 9600. Be sure to set the same number as the GP setting.

When using the following function on a GP2000 Series unit, be sure not to use duplicate port number values. Check the 2-way driver's port number setting via the following menu:

GP OFFLINE mode's Main menu [INITIALIZE] -> [SETUP OPERATION SURROUNDINGS] -> [EXTENDED SETTINGS] -> [SETUP ETHERNET INFORMATION].

The default value is 8000. The 2-way driver uses this port and the following nine ports for a total of 10 (8000 ~ 8009).

Port number's offset	Function
+1	For MtoMLan (GP-PRO/PBIII for Windows Screen Transmit)
+2	For ProNet (Pro-Server with Pro-Studio for Windows)
+3	Reserved
+4	For GP-Web
+5	Reserved
+6	For Pro-Control Editor
+7	Reserved
+8	For GP-PRO/PBIII for Windows Simulation
+9	Reserved



Be sure not to set a duplicate Node Address in the same Network Address group.

7.5.4 Error Code

Reference  About the GP Ethernet Specific Error Codes, refer to the end of this Chapter, “Protocol Stack Error Codes”.

■ PLC SPECIFIC ERROR CODES

The PLC error codes are displayed by the “Host Communication Error (02:**:**:###:###)”, and are indicated in the left lower corner of the GP screen. (**:** indicates the PLC error codes and ###:### indicates the Network Address and Node Address.) PLC error codes are shown using 2-byte, Main Response Codes and Sub Response Code.

Host Communication Error (02::**:###:###)**

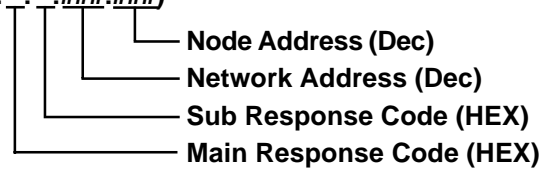

Reference  For more details about error codes, refer to Omron Communications Reference Manual for SYSMAC CS1 Series (Chapter5 FINS Commands, End Codes).

7.6 Protocol Stack Error Codes

7.6.1 Protocol Stack Error Codes

The error codes related to the protocol stack are displayed on the GP screen as follows:

PLC COM. ERROR (02:FE:**)

“**” represents any of the error codes 00 to F0 shown in the above table.

Error code	Description	Other
00	There is a setup error related to the IP address of your station at initialization.	
05	Initialization has failed.	
06	Abortion of communications has failed.	
07	An attempt was made to establish a connection before initialization was successfully completed.	
08	The port number of your station is abnormal.	
09	The port number of the destination station is abnormal.	
0A	The IP address of the other station is abnormal.	
0B	The same port number is already being used by the UDP for establishing the connection.	
0C	The same port number is already being used by the TCP for establishing the connection.	
0D	The protocol stack has refused connection establishment.	
0E	The protocol stack has returned the unsuccessful establishment of a connection.	
0F	The connection has been shut down.	
10	All the connections are busy. No connection is available.	
13	Your station is aborted by the other station	
30	There is no reply from the protocol stack	
32	There is no reply from the other station	*1
40	The designated Node Addresses do not exist in Network Information.	*1
41	I/O Memory Type for Random Read Out response data is wrong.	*1
42	Network Information does not exist.	
F0	Undefined error.	

*1 When using an Omron CSI Series unit, the error code display is as shown below. The Network Addresses and Node Addresses also are displayed.

Host Communication Error (02:FE:**:###:###)





8 Profibus-DP

8.1 Connectable PLCs

The following tables list the PLCs that can be connected and used with the GP.

PLC Maker	Series Name	CPU Type (ex.)	Notes	PLC Setting
Siemens	S7 300 S7 400	S7 315-2-DP S7 413-2-DP	Profibus unit is required	PROFIBUS





8.2 Profibus-DP

8.2.1 System Structure for Profibus-DP Connection

The following table shows the types of PLCs that can be used with Digital's GP panel.

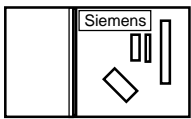
■ SIMATIC S7-300/400 Series

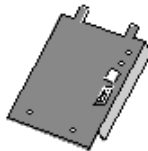
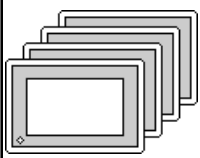
CPU	Cable Diagram	Link I/F	GP
			
S7-300 Series i.e. S7 315-2-DP S7-400 Series i.e. CPU 413-2-D	RS-485 (Cable Diagram 1)	Profibus-DP Module (GP070-PF11)	GP 470E, GP-570L, GP-570S, GP-570T, GP-675, GP477RE, GP-577RT, GP-577RS, GP-2500, GP-2600 ^{*1}

**1 For GP2000 Series, a bus conversion unit (PSL-CONV00) is required.*

■ Typical Profibus-DP System Layout

The following diagram shows the standard design of a typical Profibus-DP system.

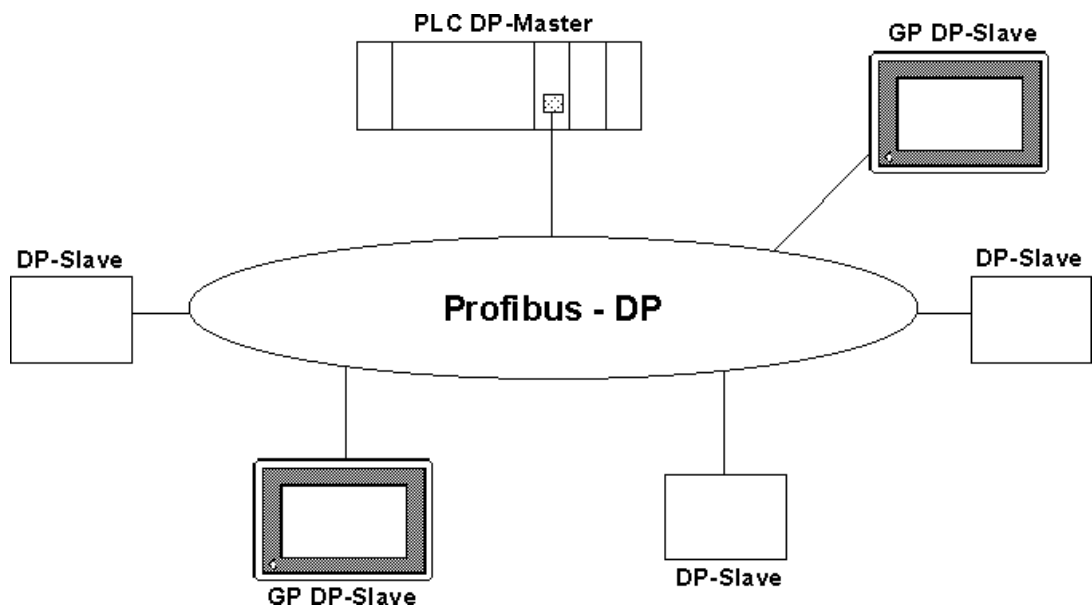



Be sure to earth the PLC's FG according to your country's earthing standards.

**(For details, please refer to the PLC maker's manual)
Pull out a small amount of the Transfer Cable's shield, make a wire out of it and connect it to the PLC's FG terminal.**



Cable Data (for S7315-2-DP model)

Parameters: Line A Line B, according to Profibus-DP DIN 19245 part1/4.91, section 3.1.2.3
Wire Gauge: >0.64mm >0.53mm
Conductor Area: >0.34mm² >0.22mm²

■ Profibus Network Layout

The maximum number of GPs that can be connected at any one time will depend on the size of the User PLC's I/O memory. For example, given the User is using a Seimens S7315-2-DP, the following connections would be possible.

Maximum No.	for Packet Transfer	-	4
of Connections	for Direct I/O	-	64

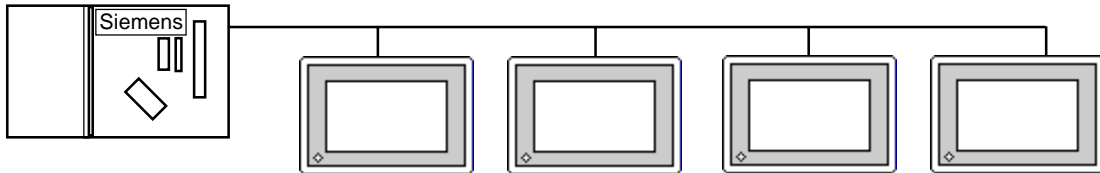

8.2.2 Data Transfer with GP via Profibus-DP

■ Data Transfer Settings

There are two modes of operation for data transfer: Direct I/O and Packet Transfer. These can be selected from the “OFFLINE mode” on the GP. Typical settings for this OFFLINE screen are shown below.

■ From the initial OFFLINE menu screen:

- 1) Select [INITIALIZE] to call up the initial settings screen.
- 2) Select the [SET UP OPERATION SURROUNDINGS] menu item (screen below appears).
- 3) Configure the environment settings to suit your particular requirements. (Ex. Direct I/O, Input/Output Area Size, etc.)



Use PRO-PBIII to set the System Area's start address. This cannot be set with the GP's OFFLINE mode.

```

SET UP OPERATION SURROUNDINGS

SYSTEM DATA AREA  START DATA BLOCK [  0010  ]

                        START DATA WORD [  000  ]

SYSTEM AREA READING AREA SIZE (0 - 256) [  0  ]

COMMUNICATION DATA TYPE                DIRECT I/O  PACKET

DIRECT I/O START ADDRESS                  [  LS0020  ]

                        INPUT AREA SIZE    [  16  ]

                        OUTPUT AREA SIZE   [  16  ]

```

■ Direct I/O

The GP can communicate with a master PLC in a very simple manner using the “Direct I/O” configuration. With this method, an area of memory is mapped from the GP’s LS area into the PLC’s input area and an area of the PLC’s output is mapped into the GP’s LS area. Set the start address of the direct I/O where you would like the GP’s internal memory to be mapped from, e.g. LS20. Set the Input and Output area sizes (in words) as required (max. 64 words). These are the sizes of the areas which will be mapped to and from the PLC and are shown below as shaded areas.



Input and output sizes must match those set up in the designated hardware configuration.

Reference this section's ■ "Configuring the GP as a Profibus-DP Slave"

This concept is illustrated below. The GP Slave Input and Output start addresses, EW40 and AW20, have been configured using the PLC programming device (for other PLC types, see relevant documentation on how to configure Input and Output addresses).

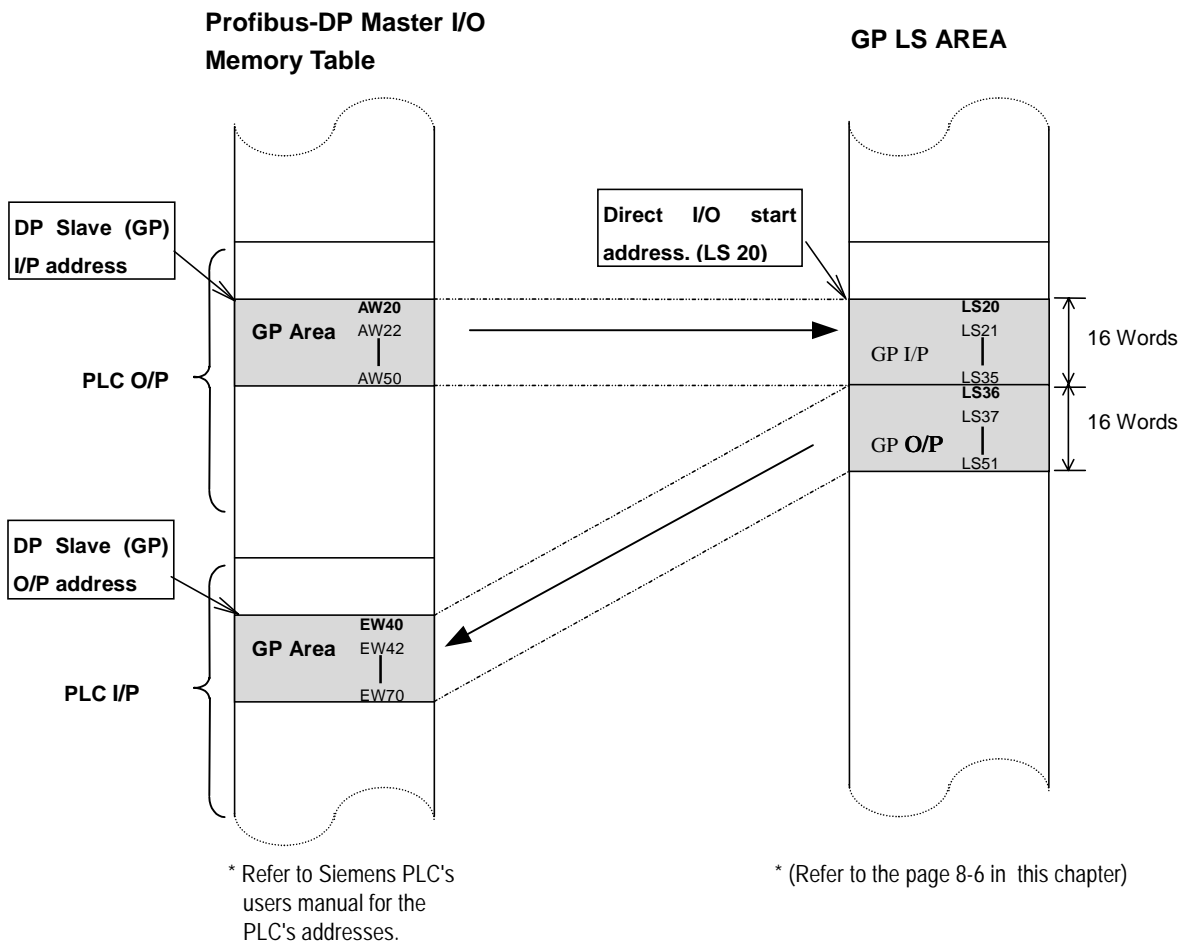

■ **Packet Transfer**

This option gives the user greater flexibility than the Direct I/O option, allowing him to read a wider range of devices. This flexibility is the result of using an interpreter program, run on the PLC, in addition to the User's own PLC program(s). For information about these items, refer to the "README.TXT" file in the " FIELDBUS" folder on the GP-PRO/PB III for Windows Ver.5.0 CD-ROM.

■ GP Packet Transfer Environment Settings

The following settings are needed to allow the GP to function in the packet transfer mode:

- 1) Use the OFFLINE screen's SETUP OPERATION SURROUNDINGS area to choose the "PACKET" communication option.
Reference "8.2.2 Data Transfer with GP via Profibus-DP"
- 2) Set this area's INPUT AREA SIZE and OUTPUT AREA SIZE settings to "0".



If the INPUT and OUTPUT AREA values are not set to "0", packet transfer cannot be performed.

■ PLC (Master) Packet Transfer Environment Settings

The Profibus interface unit must be configured as an input and output device, and both the input and output areas need to be allocated 16 bytes of PLC memory.

■ "Configuring the GP as a Profibus-DP Slave" and "Installation of Interpreter Project"

For information about these items, refer to the "README.TXT" file in the "FIELDBUS" folder on the GP-PRO/PB III for Windows Ver.5.0 CD-ROM.

8.2.3 Cable Diagram

The following cable diagram should be used when making a cable for the Profibus-DP cable's connector.

Cable Diagram 1 RS-485

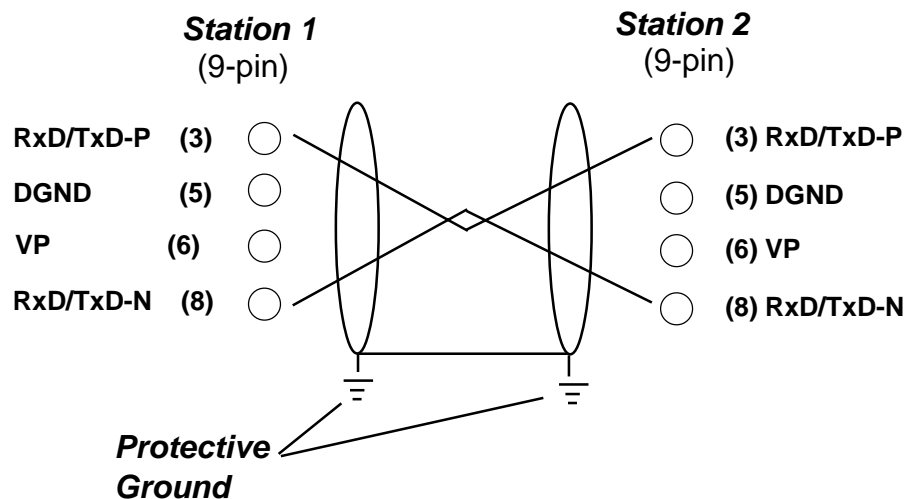

8.2.4 Supported Devices

■ Profibus-DP (for Direct I/O)

The range of devices supported by the GP is shown below.

Device	Bit Addresses	Word Addresses	Note
LS	LS00200 - LS1999F	LS0020 - LS1999	



- **The User must confirm that sufficient memory is available for the Input and Output areas. For example, if the User chooses 32 words I/P and 32 words O/P, the maximum value for the Direct I/O start address is LS1935.**
- **The System Area function is NOT available in DIO mode.**

■ SIMATIC S7-300/400 Series (for Packet Transfer)

 Setup System Area here.

Device	Bit Address	Word Address	Note
Data register		DB2W0000 - DB60W65534	*1, *2
Input relay	I000000- I655357	IW00000- IW65534	*3, *4
Output relay	O000000 - O655357	OW00000 - OW65534	*3
Internal memory	M00000 - M655357	MW00000 - MW65534	*3

*1 The data range used for the Data Register must be set up in the PLC by the User. Please confirm that all data addresses referenced actually exist (are valid).

*2 The S7 Data Register uses the following Byte Addressing method:

E.g. DB2W 50

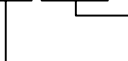
 Represents data Word 50. Values 0 to 65534 are valid. (even addressing only)

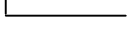
 Represents data Block 2. Values DB2W - DB60W are valid.

*3 The Bit Device illustration is as follows:

E.g,

GP Inscription	PLC Inscription
I0007	I0.7

*4 The Input relay device cannot be written from the GP.



- Failure to configure the Profibus unit correctly can result in inconsistent GP operation on the Profibus network.
- This protocol is intended to be used as a generic protocol for all Profibus PLC's. As a result, the ranges and devices stated here are not intended for any single PLC maker. The user should be sure to check that all values used are those required for their specific PLC.

Environment Setup Cautions

- The user must be sure to use the normal Profibus configuration software to configure the GP unit for use on the Profibus network. Also, the User must ensure that all devices and addresses designated actually exist, otherwise the User's PLC may stop.
- When using the Siemens S7 family of PLCs, the system area start address must be set via the editor software.
- The user must be sure that the System Area's start address is set so that sufficient memory is available for all the System Area used. For example, if 10 words of system area are used, the maximum start area address would be 65524.



Use PRO-PBIII to set the System Area's start address. This cannot be set with the GP's OFFLINE mode.

8.2.5 Environment Setup

■ GP Data Transfer Settings

		GP Settings	
Data Transfer Speed		9.6K to 12Mbps *1	
Data Transfer Method	RS-485		
System Area Start Address		DB2W0	DB60W65514
Station No. *2		0	127

 : Default Settings

- *1 The data transfer speed is automatically changed, according to the ladder software's specifications. Thus, setting this speed via the GP is not necessary.
- *2 Station No.s are set via the Profibus Rotary Switches.

■ Data Transfer Setup Checklist

The following items should be confirmed prior to transferring data on the Profibus network.

- 1) Be sure that all the installation procedures have been followed.
- 2) Be sure the Profibus unit's two rotary switches are set correctly and, if required, a terminating resistor is used.
- 3) If necessary, be sure the default hardware configuration provided on the Installation disk has been modified correctly.
- 4) Be sure to use the GP's OFFLINE Mode screens to designate the correct options for either a Packet Transfer or Direct I/O configuration. (Use the steps shown below to call up this screen)

From the initial OFFLINE menu screen:

- 1) Select [INITIALIZE] to call up the initial settings screen.
- 2) Select the [SET UP OPERATION SURROUNDINGS] menu item (next screen appears).
- 3) Configure the environment settings to suit your particular requirements. (Ex. Direct I/O, Input/Output Area Size, etc.)

■ "Configuring the GP as a Profibus-DP Slave" and "Installation of Interpreter Project"

For information about these items, refer to the "README.TXT" file in the "FIELDBUS" folder on the GP-PRO/PB III for Windows Ver5.0 CD-ROM.

8.2.6 Profibus Specific Error Codes

If the error code “PLC COM. ERROR (02:F6)” appears on the screen after data has been downloaded from the User’s PC to the GP unit, one of the following problems may have occurred.

- 1) The User has configured the GP to operate in Direct I/O mode, and is now trying to reference devices other than those designated in LS memory.
- 2) The User is running the GP in Direct I/O mode, and the system memory area has not been cleared. (Set to “0”)

Error Code	How to Correct
PLC COM Error 02:F6 ^{*1}	1) Be sure that your screen data uses only the designated LS area(s). 2) Reset the System Area (to all zeroes).

**1 For information about other types of error messages, refer to the Operation manual’s error message appendix.*



If the data transmission cable is accidentally cut or disconnected for a long period of time, a system error will occur, which will cause the system to hangup. (Error Codes: 005:02D:010 or 008:02D:010)



9 CC-Link

In this chapter, the GP panel CC-Link unit's range of compatible PLCs, their system design and the range of applicable devices are explained.

9.1 Connectable PLCs

The chart below shows the range of PLCs that can be connected to the CC-Link.

■ Remote Device Station

	Series Name	CPU	Link I/F Unit or CPU Direct Connection	Special Conditions	GP-Pro/PBIII [PLC Type] selection
Mitsubishi	A Series	A2A A3A A3N A2U-S1	CC-Link Unit A Series AJ61BT11	CC-Link Compatible unit is required	CC-Link Type
		A2US A2USH-S1	A Series A1SJ61BT11		
	QnA Series	Q3A Q4A	QnA Series AJ61QBT11		

■ Intelligent Device Station

	Series Name	CPU	CC-Link Unit	Special Conditions	GP-Pro/PBIII [PLC Type] selection
Mitsubishi Electric Corp.	MELSEC-A	A1S A1SH A1SJ A1SJH A1SCPUC24-R2 A2S A2SH A2US A2US-S1 A2USH-S1	A1SJ61BT11	(PLC) CC-Link unit's software version J or higher	CC-Link intelligent device
		A0J2H A1N A2N A2N-S1 A3N A3H A2A A2A-S1 A3A A2U A2U-S1 A3U A4U	AJ61BT11		



■ Intelligent Device Station

	Series Name	CPU	CC-Link Unit	Special Conditions	GP-Pro/PBIII [PLC Type] selection
Mitsubishi Electric Corp.	MELSEC-QnA	Q2AS Q2ASH	A1SJ61QBT11	(PLC) CC-Link unit's software version J or higher	CC-Link intelligent device
		Q2A Q2A-S1 Q3A Q4A Q4AR	AJ61QBT11		
	MELSEC-Q	Q02CPU Q02HCPU Q06HCPU Q12HCPU Q25HCPU	QJ61BT11		
		Q02CPU-A Q02HCPU-A Q06HCPU-A	A1SJ61BT11	A Mode CPU	

9.2 Remote Device Station

9.2.1 System Structure

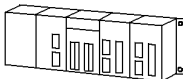
■ A series/QnA series (Link I/F)

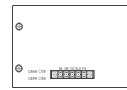
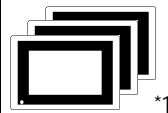
CPU	Link	Wiring Drawing	Cable(s)	Unit	GP
					
A2A A3A A3N A2U-S1	AJ61BT11	RS485 (refer to next page)	Kuramo Electronics' Model: FANC-SB0.5mm ² x3	CC-Link Unit Model: GP070-CL11	GP Series *2
A2US A2USH-S1	A1SJ61BT11		Twisted Pair Shielded Cable		
Q3A Q4A	AJ61QBT11				

*1 All GP Units connected to the Master station have the following conditions:

$$(1) \{(1 \times a) + (2 \times b) + (3 \times c) + (4 \times d)\} \leq 64$$

a: No. of units occupying 1 node

b: No. of units occupying 2 nodes

c: No. of units occupying 3 nodes

d: No. of units occupying 4 nodes

$$(2) \{(16 \times A) + (54 \times B) + (88 \times C)\} \leq 2304$$

A: No. of Remote I/O nodes used ≤ 64

B: No. of Remote Device nodes ≤ 42

C: No. of Local nodes ≤ 26

Maximum No. of Connectable GPs

The GP will become a Remote Device node and the minimum number of occupyable nodes becomes two (2). As a result, the number of GPs that can be connected to a single Master node is 32.

Reference For detailed information about the Master node's system design, please refer to *Mitsubishi Electric [AJ61BT11/A1SJ61BT11] Unit CC-Link System Master and Local Unit User's Manual*, or the *[AJ61QBT11/A1SJ61QBT11] Unit CC-Link System Master and Local Unit User's Manual's [System Design] section*.

*2 Applicable GP units: GP-470E, GP-570T, GP-570S, GP-570L, GP-57JS, GP-570VM, GP-571T, GP-675T, GP-675S, GP-870VM, GP-477RE, GP-577RT, GP-577RS, GP-2500T, GP-2501T, and GP-2600T. For GP2000 Series units, however, a bus conversion unit (PSL-CONV00) is required.

9.2.2 Cable Diagram

When connecting the GP (Remote Unit) to the PLC (Master Unit), use twisted pair cable and wire the connectors as follows:

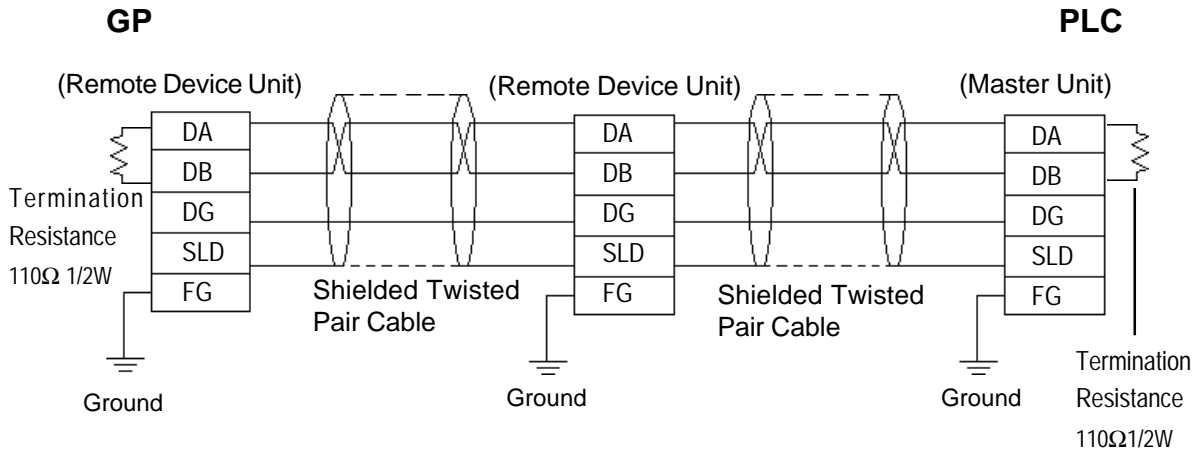

- **Be sure to attach termination resistors to each end of a linked system, between DA-DB. A Terminating Resistor is already attached to the PLC's CC-Link unit.**
- **The GP becomes the remote device node.**
- **The node order and the actual unit connection order are not related.**
- **T-type and Star-type connections are not possible.**

9.2.3 Environment Settings

The following are Digital’s recommended data transmission settings for the PLC and GP.

■ **Mitsubishi Electric A and Q Series Units**

GP Settings		PLC CC-Link Unit Settings	
Transfer Speed	10M, 5M, 2.5M, 625K, 156K	Transfer Speed	Set via Rotary Switch
Occupied Nodes	2 to 4	Occupied Nodes	Ladder program is used to set no. of occupied nodes in the Node Information area. *1
No. of Nodes	1 to 63	No. of Nodes	Ladder program is used to set Node No. in the Node Information area. *1 *2
Node Type	Remote Device Station (fixed)	Node Type	Ladder program is used to set the Node Type in the Node Information area. *1
Monitoring Method	Ordinary Monitor, Command Monitor	Monitoring Method	Can be entered via Ladder program *3
Environment Settings	Use GP screen to enter settings (See Foot Note *4)		

*1 For detailed information about the Master station’s system design, please refer to **Mitsubishi Electric [AJ61BT11/A1SJ61BT11] Unit CC-Link System Master and Local Unit User’s Manual**, or the **[AJ61QBT11/A1SJ61QBT11 Unit CC-Link System Master and Local Unit User] Manual’s [System Design] section**.

*2 The Master Node’s node number must always be set to “0”. (Use the Master Unit’s rotary switch)

*3 Only the settings on the GP can be changed. If, however, a ladder program has been used to enter settings (using Initial Setting commands), those settings are the highest priority.

*4 (HOW TO SET UP THE GP SCREEN)

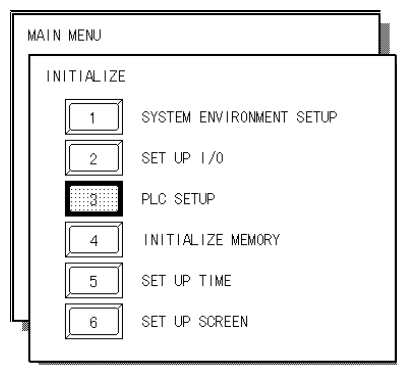

1. Touch the [PLC SETUP] selection.

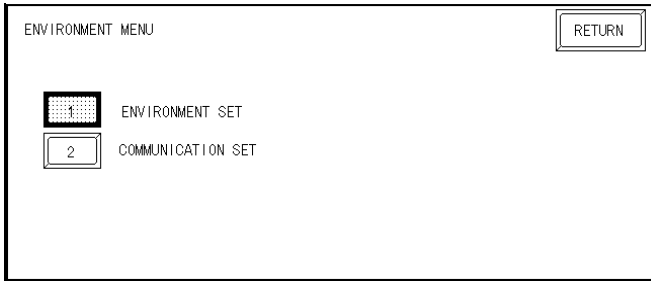

2. Touch the [ENVIRONMENT SET] selection.

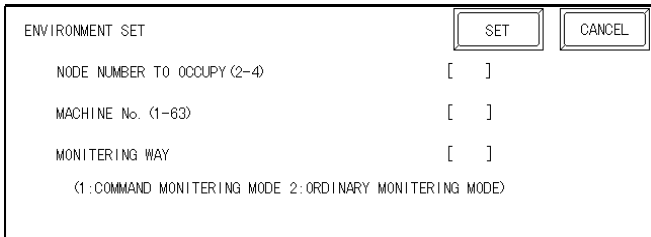

In the [ENVIRONMENT SET] menu:
Enter the desired settings for Node Number to Occupy, Machine No. and Monitoring Way.

NODE NUMBER TO OCCUPY enter 2, 3 or 4.

MACHINE NO. enter from 1 to 63 for the machine number. If “3” occupied nodes are used, the limit is 62; if “4” occupied nodes are used, the limit is 61.

MONITORING WAY either Command or Ordinary Monitoring can be used.

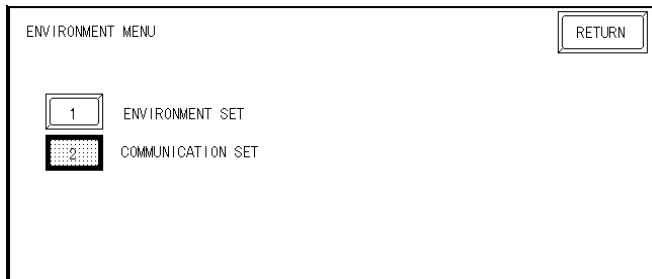

3. Touch the [COMMUNICATION SET] selection.

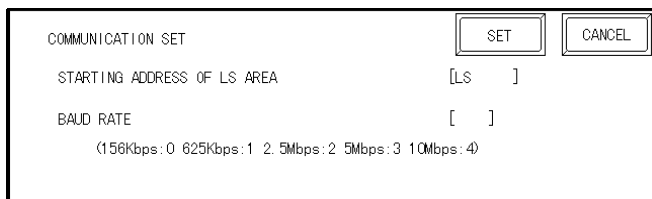

In the [COMMUNICATION SET] menu:

Enter the [STARTING ADDRESS OF LS AREA] and [BAUD RATE] settings.

STARTING ADDRESS OF LS AREA This start address is used for the allocation of the Remote Input/Output and Remote Device Areas in the GP’s System Area (20 to 1980).

9.2.4 Monitoring Specifications

9.2.4.1 Overview

When using the CC-Link, the GP must be registered as a Remote Device node and use a direct connection with a CC-Link compatible PLC. Here, either the Ordinary or Command Monitoring method can be used.

◆ Ordinary Monitoring

The Master Node's devices are occupied (via Link Areas) in the GP's System Area, as shown below.

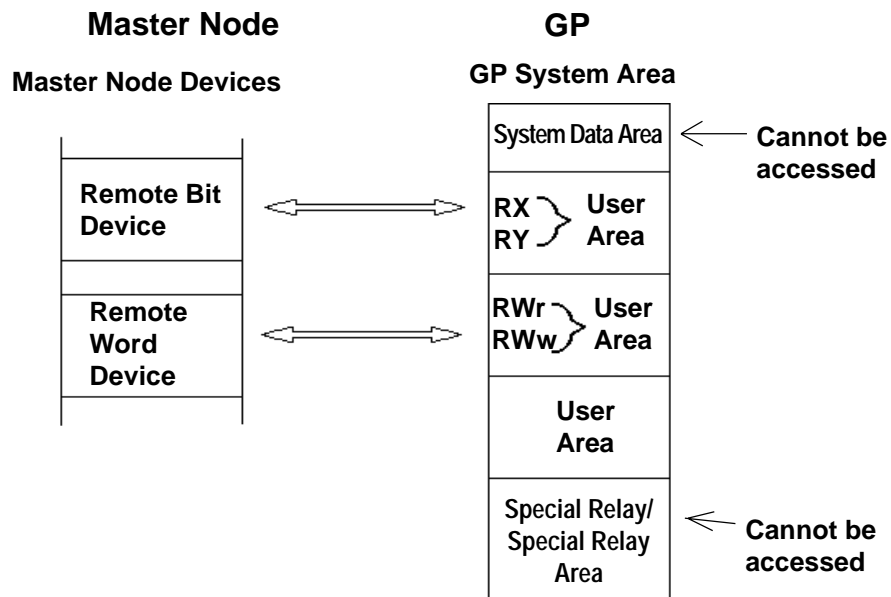

When using the Ordinary Monitoring method, the System Device Area and the Special Relay Area cannot be accessed.

• **Command Monitoring**

The Remote Bit Device, like the Ordinary Monitor, can directly access the User Area's Bit Device.

The Remote Word Device, depending on the commands entered to the device, can directly access the GP's User and System areas.

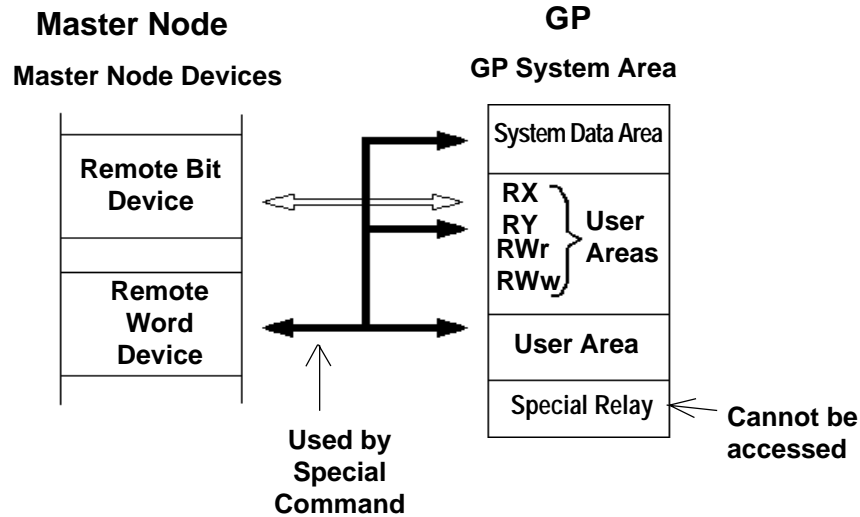

• **Using Indirect Access**

The CC-Link Special Command (write/read commands) can be used to store/access data in the GP System Area's Remote Word Device.

Reference 9.2.3 ■ *Command Monitoring*



- **The contents of the System Data Area will convert to Memory Link type.**
- **When using Command Monitoring, data cannot be written to the RX, RY, RWw, or RWr user areas.**
- **The GP's Special Relay area cannot be accessed.**

■GP I/O Designations

From GP to Master Station

Link Output	Signal Name
RX m0	User Area The following number of nodes can be occupied: 2 nodes: 48 points 3 nodes: 80 points 4 nodes: 112 points
RX m1	
RX m2	
RX m3	
RX m4	
RX m5	
RX m6	
RX m7	
RX m8	
RX m9	
RX mA	
RX mB	
RX mC	
RX mD	
RX mE	
RX mF	
::	
RX (m+n) 0	Display Completed Flag
RX (m+n) 1	Reserved for System Area
RX (m+n) 2	
RX (m+n) 3	
RX (m+n) 4	Reserved
RX (m+n) 5	Touch ON Completed Flag
RX (m+n) 6	Reserved
RX (m+n) 7	Tag Code Output Request Flag
RX (m+n) 8	Reserved
RX (m+n) 9	Initial Data Setting Completed Flag
RX (m+n) A	Error Condition Flag
RX (m+n) B	Remote Ready
RX (m+n) C	Reserved
RX (m+n) D	Reserved
RX (m+n) E	Reserved
RX (m+n) F	Reserved

From Master Station to GP

Link Output	Signal Name
RY m0	User Area The following number of nodes can be occupied: 2 nodes: 48 points 3 nodes: 80 points 4 nodes: 112 points
RY m1	
RY m2	
RY m3	
RY m4	
RY m5	
RY m6	
RY m7	
RY m8	
RY m9	
RY mA	
RY mB	
RY mC	
RY mD	
RY mE	
RY mF	
::	
RY (m+n) 0	Display Request Flag
RY (m+n) 1	Display Monitor Request Flag
RY (m+n) 2	Display Periodic Write Request Flag
RY (m+n) 3	Reserved for System Area
RY (m+n) 4	
RY (m+n) 5	
RY (m+n) 6	
RY (m+n) 7	
RY (m+n) 8	Reserved
RY (m+n) 9	Initial Data Setting Request Flag
RY (m+n) A	Error Reset Request Flag
RY (m+n) B	Reserved
RY (m+n) C	Reserved
RY (m+n) D	Reserved
RY (m+n) E	Reserved
RY (m+n) F	Reserved



m: (Node No. - 1) x 2h

n: As stated below

No. of Occupied Nodes	2 Nodes	3 Nodes	4 Nodes
n	3	5	7

• GP I/O Definition Details

From GP to Master Station

Link Input	Signal Name	Explanation
RX (m+n) 0	Display Completed Flag *1	When the Display Completed Flag (RY (m+n)0) turns ON, the GP's Processing Completed will turn ON. Also, when the GP turns the Display Request Flag OFF, the Display Completed Flag also turns OFF.
RX (m+n) 5	Touch ON Completed Flag	When data is written to the GP's System Data Area 13, Rx(m+n)5 will turn ON. The PLC then uses the Continuous Read Command, and, after reading the contents of the GP's System Data Area 13, it turns OFF.
RX (m+n) 7	Tag Code Output Request Flag	Same as RX(m+n)5.
RX (m+n) 9	Initial Data Setting Completed Flag *1	When the Initial Data Setting Request (RY(m+n)9) turns ON, the Initial Data Setting Completed will also turn ON. Also, when the Initial Data Setting is completed, the Initial Data Setting Request Flag and the Initial Data Setting Completed Flag will both turn OFF.
RX (m+n) A	Error Condition Flag	When a command error occurs while the GP's System Area is being used, this flag turns ON.
RX (m+n) B	Remote Ready	When the GP has been changed to ONLINE mode and data linking has been completed successfully, this turns ON. Also, when the GP is in either OFFLINE mode or having its Initial Data entered, this turns OFF.

From Master Station to GP

Link Input	Signal Name	Explanation
RY (m+n) 0	Display Request Flag *1	When a read or write are being performed to the GP's System Area, this flag turns ON.
RY (m+n) 1	Display Monitor Request Flag *1	When the System Area is being read of a GP that has had Monitor Registration performed for its RWm area, this flag turns ON.
RY (m+n) 2	Display Periodic Write Request Flag *1	When the System Area is being written to on a GP that has been registered for the periodic writing of data previously written to the RWwm area, this flag turns ON.
RY (m+n) 9	Initial Data Setting Request Flag *1	Initial processing is performed when this flag is ON.
RY (m+n) A	Error Reset Request Flag	When the Error Reset Request Flag turns ON, the Error Condition Flag RX(m+n)A turns OFF.

*1 Only needed during Special Command Monitor. Normally not used.

- **Display Completed Flag, Display Request Flag**

When the Display Request Flag turns ON, the completion of command processing causes the Display Completed Flag to turn ON. When the Display Request Flag turns OFF, the Display Completed Flag will also turn OFF. Be sure to use the ladder program to turn OFF the Display Request Flag after checking the Display Completed Flag has been turned ON.

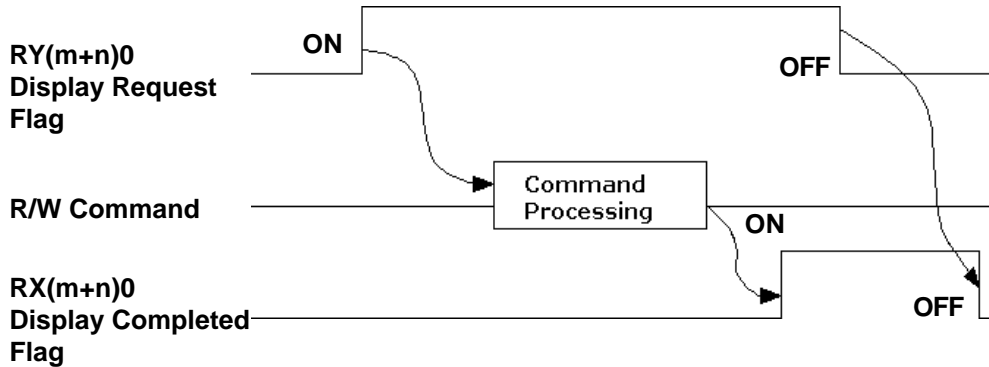

- **Initial Data Setting Completed Flag, Initial Data Setting Request Flag**

When the Initial Data Setting Completed Flag turns ON, the completion of the initial processing causes the Initial Data Setting Completed Flag to turn ON. When the Initial Data Setting Request Flag turns OFF, the Initial Data Setting Completed Flag turns OFF.

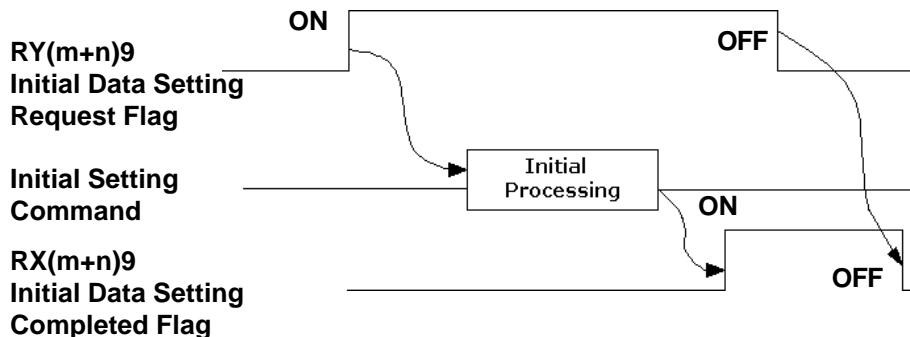

- **Error Condition Flag, Error Reset Request Flag**

When the Command Monitor feature is being used and an error occurs, the Error Condition Flag and the Error Reset Request Flags both turn ON, causing the Error Condition Flag to turn OFF..

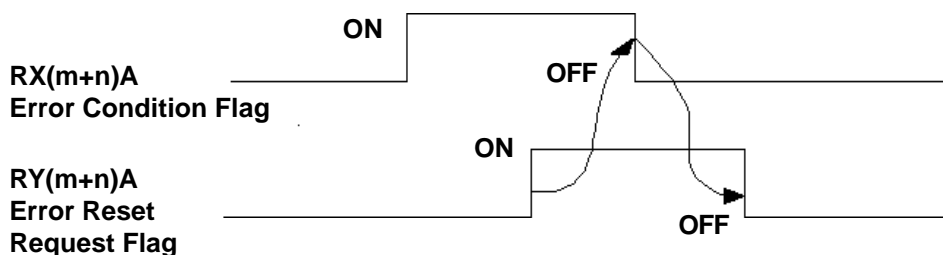

- **Display Monitor Request Flag**

When the Display Monitor Request Flag turns ON, data from the system area of the GP registered for monitoring will be read out.

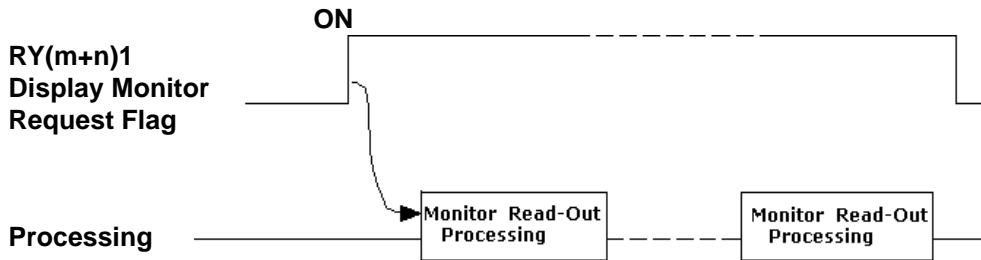

- **Periodic Display Write Request Flag**

While the Periodic Display Write Request is ON, data is periodically written to a registered GP's system area.

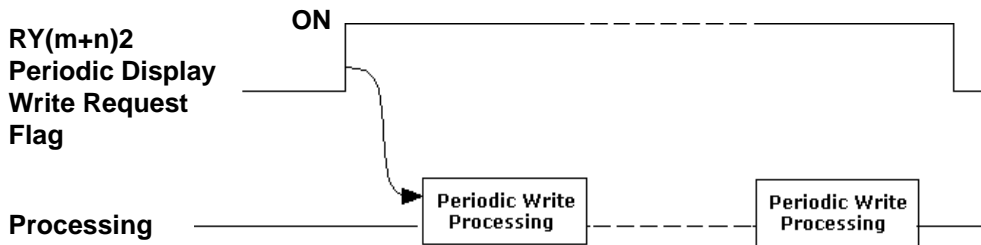

- **Remote Ready**

When the GP's OS is started and online, the Remote Ready:RX(m+n)B bit is ON.

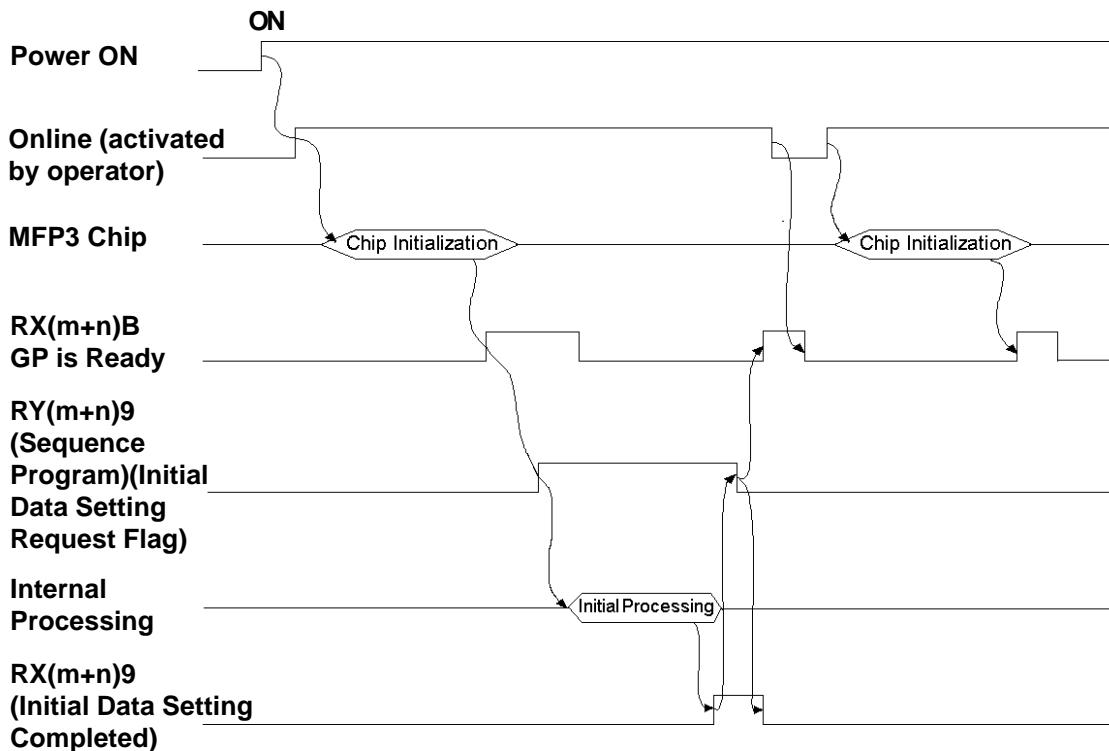

■ Sending Tag Codes to the Master Node

This feature is for sending Tag Code data from the GP's System Area to the Master Node, via the GP's touch panel. When a GP touch or other type of tag is used to perform an absolute write to the GP's System Data Area 13 (decimal), the RX(m+n)5 (Touch ON Complete Flag) turns ON. When this bit turns ON, the RX(m+n)7 (Tag Code Read Request Flag) also turns ON.

When the Master Node is performing continuous read requests on the GP's System Data Area 13, prior to a Read being completed, the GP will turn RX(m+n)5 OFF. This, in turn, will cause the RX(m+n)7 bit to turn OFF. This method is used to send numeric data from the GP's touch panel (using the 8 bit interrupt codes shown below) to the Master Node.

• Input/Output Signal Timing

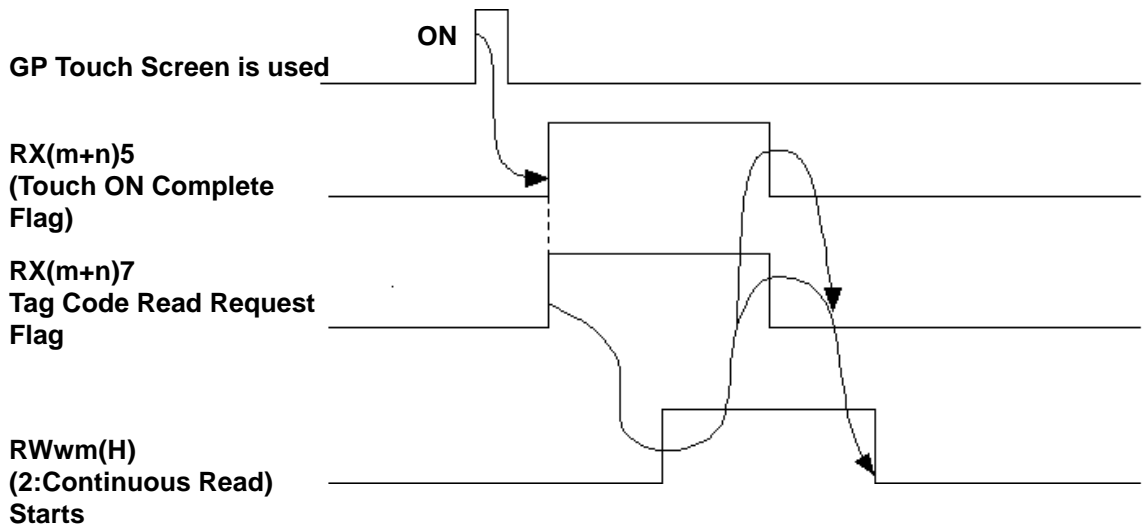

9.2.4.2 Ordinary Monitoring

- GP Register Descriptions

From Master Station to GP

Address	Contents
RW wm	When 2 Nodes are occupied: 8 points
RW wm+1	
RW wm+2	
RW wm+3	
RW wm+4	
RW wm+5	
RW wm+6	
RW wm+7	
RW wm+8	When 3 Nodes are occupied: 12 points
RW wm+9	
RW wm+A	
RW wm+B	
RW wm+C	When 4 Nodes are occupied: 16 points
RW wm+D	
RW wm+E	
RW wm+F	

From GP to Master Station

Address	Contents
RW rn	When 2 Nodes are occupied: 8 points
RW rn+1	
RW rn+2	
RW rn+3	
RW rn+4	
RW rn+5	
RW rn+6	
RW rn+7	
RW rn+8	When 3 Nodes are occupied: 12 points
RW rn+9	
RW rn+A	
RW rn+B	
RW rn+C	When 4 Nodes are occupied: 16 points
RW rn+D	
RW rn+E	
RW rn+F	



Concerning the characters m and n:
The chart here shows how the Remote Register's 4h units are calculated.

Machine No.	m	n
1	0	100
2	4	104
3	8	108
~	~	~



With Ordinary Monitoring, the value written into the Master Node's RWw area is reflected in the User Area's Link Area RWw(+36 to +51). Also, the value in the User Area's Link Area RWr(+20 to +35) is reflected in the Master Node's RWr.

Reference refer to 9.2.3 ■ Occupied Nodes.

- Ordinary Monitoring Sequence Drawing

(Sequence Program)

X6 (Depending on buffer memory parameters, Data Link Start OK Completed)

—| | _____ [M120]—

M120

—| | _____ [TO H0 H1E0 D119 K8]—

| (8 word setting for data written from D119)

_____ [FROM H0 H2E0 D219 K8]—

(8 word setting for data read into D219)

■ PLC (Sequencer) Program for Displaying Ordinary Monitor Data

The following drawing shows the PLC's CPU and Master Node Buffer Memory, in addition to the GP's System Data Area.

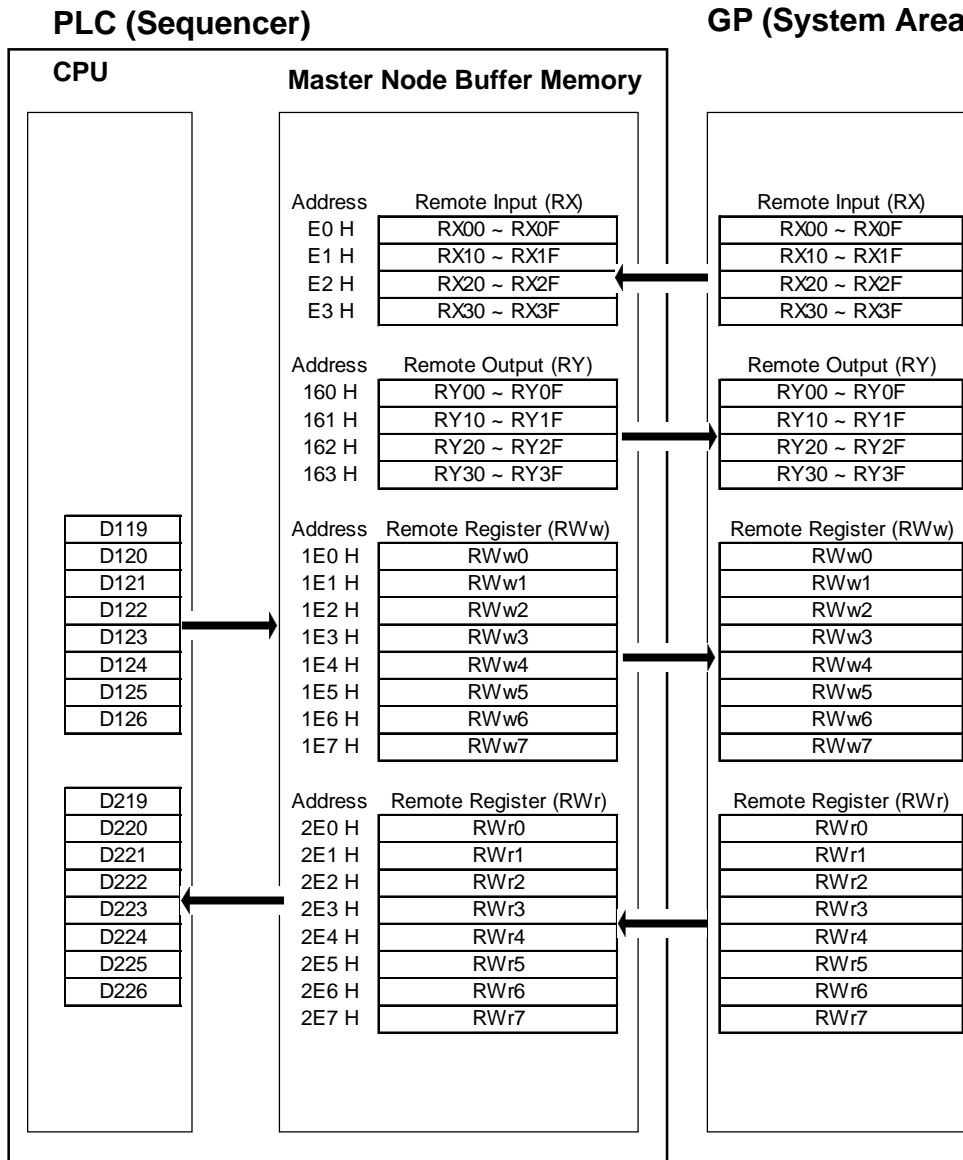

The above chart shows examples of when the CPU's D119 to D126 data is sent to RWw0 to RWw7, and when RWr0 to RWr7's data is sent to D219 to D226.

9.2.4.3 Command Monitoring

■ GP Register Descriptions

◆ Master Node to GP

Address	Contents
RW wm	Command
RW wm+1	When each command (refer to the each command details) occupies 2 Nodes: 8 points.
RW wm+2	
RW wm+3	
RW wm+4	
RW wm+5	
RW wm+6	
RW wm+7	
RW wm+8	
RW wm+9	When 3 Nodes are occupied: 12 points
RW wm+A	
RW wm+B	
RW wm+C	When 4 Nodes are occupied: 16 points
RW wm+D	
RW wm+E	
RW wm+F	

◆ GP to Master Node

Address	Contents
RW rn	Response *1
RW rn+1	When each command (refer to the each command details) occupies 2 Nodes: 8 points.
RW rn+2	
RW rn+3	
RW rn+4	
RW rn+5	
RW rn+6	
RW rn+7	
RW rn+8	When 3 Nodes are occupied: 12 points
RW rn+9	
RW rn+A	
RW rn+B	When 4 Nodes are occupied: 16 points
RW rn+C	
RW rn+D	
RW rn+E	
RW rn+F	



Concerning the characters m and n:
The chart here shows how the Remote Register's 4h units are calculated.

Machine No.	m	n
1	0	100
2	4	104
3	8	108
~	~	~

**1 Error code will be set only when errors occur.*

■ Signal Details

The following drawing shows the PLC's CPU and Master Node Buffer Memory, in addition to the GP's System Data Area.

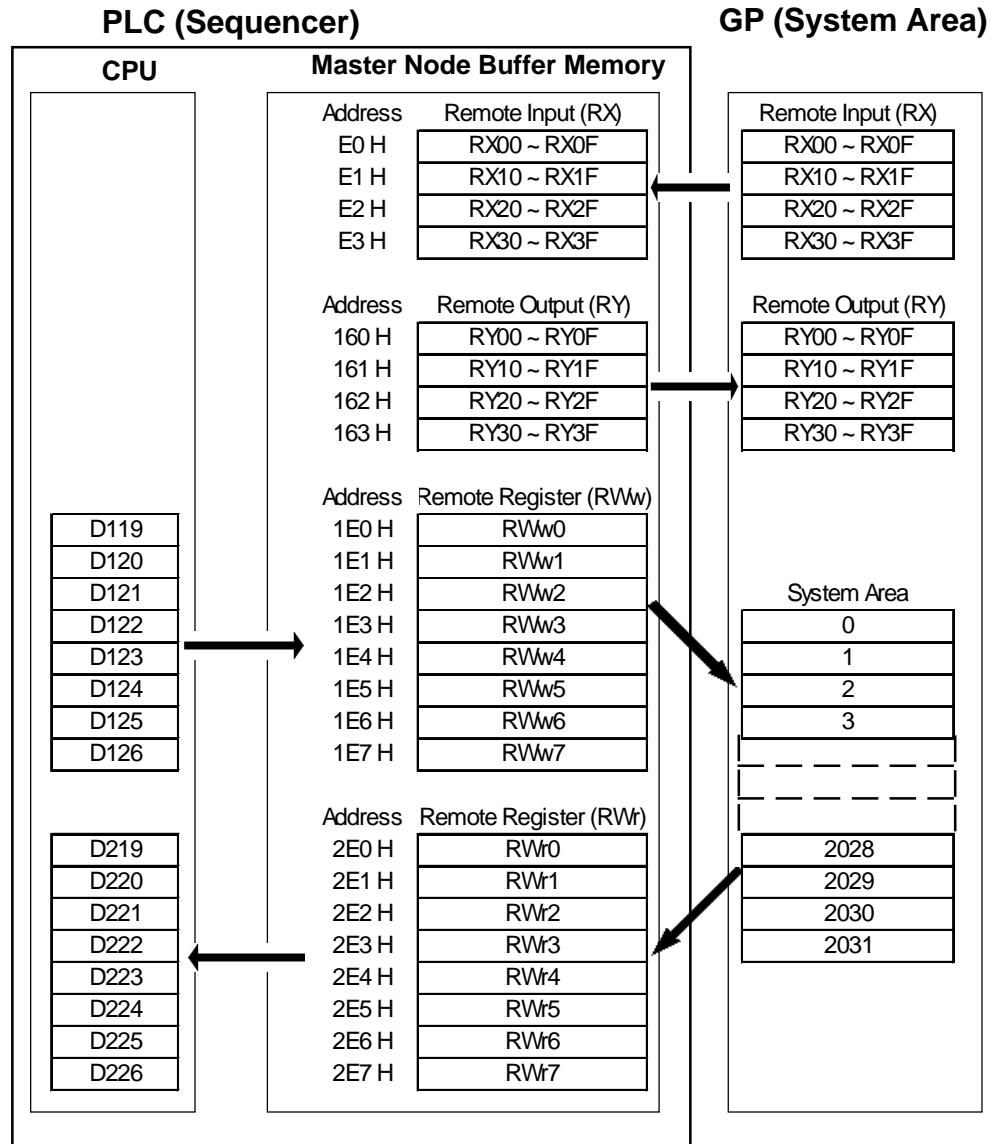

The figures show the PLC CPU's D119 used as the start address for the storage of commands, with D129 being used as the start address for the storage of read out data.

◆ Command List

Command No.	Name	Contents
1	Initial Setting Command	Changes the current Mode.
2	Continous Read Command	Reads out each piece of word data from the GP System Area's designated address.
3	Random Read Command	Reads out data from multiple GP System Area addresses.
4	Continuous Write Command	Writes each piece of word data to the designated GP System Area address.
5	Random Write Command	Writes data to multiple GP System Area addresses.
6	Register Monitor Command	Registers multiple GP System Area addresses for monitoring.
8	Register Periodic Write Command	Registers multiple GP System Area addresses for writing.

■ Initial Setting Command

Address	Contents
RWwm (H)	1: Initial Settings
RWwm (L)	1: Use Command Monitor Mode 2: Use Ordinary Monitor Mode
RWwm +1 to RWwm +F	Cannot be used
RWrn to RWrn +F	Cannot be used



The Initial Setting command (either Ordinary or Command Monitor) can also be designated via the GP's OFFLINE mode. However, if this command is designated via a ladder program, the ladder program has priority. If no ladder program settings are present, the OFFLINE mode settings are enabled.

< Sequence Program Example > (Uses Initial Setting command to operate the Command Monitoring Mode.)

```

— [ <> k 1 D 1 0 0 0 ] ————— [ MOV H 1 0 1 D 1 1 9 ] —
                    (Initial Setting Command (H) and Command Monitor Mode (L) settings)
                    ————— [ TO H 0 H 1 E 0 D 1 1 9 K 1 ] —
                    | (Save the above settings to the designated buffer address)
                    ————— [ TO H 0 H 1 6 3 H 2 0 0 K 1 ] —

(Initial Data Setting Request Flag ON)
M 9036(Normally ON)
— | | ————— [ FROM H 0 H E 3 D 1 0 0 0 K 1 ] —
|                    (Save Initial Data Setting Completed Flag to D1000)
                    ————— [ SFR D 1 0 0 0 K 9 ] —
                    (Shift all data 9 bits to the right)

— [ = k 1 D 1 0 0 0 ] — Ladder program for performing another command
    
```

■ Continuous Read Command

Address	Contents
RWwm (H)	2: Continuous Read
RWwm (L)	1-14: No. of Words (W/4 occupied nodes: max. 14 points, w/3 occupied nodes: max. 10 points, w/2 occupied nodes: max. 6 points)
RWwm +1	0 to 2031: GP System Area's designated address
RWwm +2 to RWwm +F	Cannot be used
RWrn to RWrn +D	Reads out each piece of word data from the GP System Area's designated address.
RWrn +E to RWrn +F	Cannot be used

< Sequence Program Example > (Continuous Read of 6 words from address 0 in GP memory)

X6 (Data Link normal startup completed using buffer memory's parameter)

```

—| |-----[ SET M110 ]—
M110
—| |-----[ MOV K518 D119 ]—

| ( Sets 2 : Continuous Read(H), and 6 : no. of points(L) )
|-----[ MOV K0 D120 ]—
| ( Designates Address 0 in GP Memory )
|-----[ TO H0 H1E0 D119 K2 ]
| ( Saves above settings to the buffer memory )
|-----[ MOV K1 D149 ]—
|
|-----[ TO H0 H163 D149 K1 ]
| ( GP Request Flag ON )
|-----[ FROM H0 H2E0 D229 K6 ]—
( Saves Continuous Read values in device D229)

```

In order to send T-tag data to a PLC, and also enable the master station to read the touched value using the Continuous Read command.

< Sequence Program Example (Using LS13) >

(Values in brackets() are when LS10 is used)

```

X6 (Data Link normal startup completed using buffer memory's parameter)
—| |-----[ SET M110 ]—
M9036 (Normally ON)
—| |-----[ FROM H0 HE3 D1000 K1 ]—
| (Saves Data stored in Buffer memory to D1000)
|-----[ SFR D1000 K5 ]—
(Shifts all data 5 bits to the right) (K6)
—[ =H45 D1000 ]-----[ MOV K518 D119 ]—
(H23) | (Designates 6 words for Continuous Read)
(Touch ON Completed Flag)-----[ MOV K13 D120 ]—
| (K10) (Set address13 in the GP internal memory)
|-----[ TO H0 H1E0 D119 K2 ]—
| ( Saves above settings to buffer memory )
|-----[ MOV K1 D149 ]—
|
|-----[ TO H0 H163 D149 K1 ]—
(GP Request Flag ON)

```

■ Random Read Command

Address	Contents
RWwm (H)	3: Random Read
RWwm (L)	1-14: No. of Words (W/4 occupied nodes: max. 14 points, w/3 occupied nodes: max. 10 points, w/2 occupied nodes: max. 6 points)
RWwm +1 to RWrn +F	0 to 2031: GP System Area's designated address
RWrn to RWrn +D	Reads out each piece of word data from the GP System Area's designated address.
RWrn +E to RWrn +F	Cannot be used

< Sequence Program Example > (For random read GP memory address 100)

X6 (Data Link normal startup completed using buffer memory's parameter)

```

—| |————— [ SET M110 ]—
M110
—| |————— [ MOV K769 D119 ]—
| ( Designates 3 : Random Read(H), and 1 : no. of points(L) )
|————— [ MOV K100 D120 ]—
| ( Designates address 100 in the GP internal Memory)
|————— [ TO H0 H1E0 D119 K2 ]
| ( Saves above settings to buffer memory)
|————— [ MOV K1 D149 ]—
|
|————— [ TO H0 H163 D149 K1 ]
| (Display Request Flag ON)
|————— [ FROM H0 H2E0 D229 K1 ]—
( Saves Random Read values in device D229)
    
```

■ Continuous Write Command

Address	Contents
RWwm (H)	4: Continuous Write
RWwm (L)	1-14: No. of Words (W/4 occupied nodes: max. 14 points, w/3 occupied nodes: max. 10 points, w/2 occupied nodes: max. 6 points)
RWwm +1	0 to 2031: GP System Area's designated address
RWwm +2 to RWwm +F	Write data
RWrn to RWrn +F	Cannot be used



Data cannot be written to the Link area.

< Sequence Program Example > (Writes 6 words units continuously from GP memory address 2026. This example uses Write data 1,2,3,4,5 and 6.)

```

X6 (Data Link normal startup completed using buffer memory's parameter)
┌───┴───┐────────────────────────────────────────── [ SET M110 ]───┐
M110
┌───┴───┐────────────────────────────────────────── [ MOV K1030 D119 ]───┐
    |
    | (Designates 4 : Continuous Write(H), and 6 : no. of points(L) )
    └───┬───┘────────────────────────────────────────── [ MOV K2026 D120 ]───┐
    | (Designates addresses in GP memory)
    └───┬───┘ [ MOV K1 D121 ]───┐
    | (Write 1 to address 2026 in GP memory)
    └───┬───┘ [ MOV K2 D122 ]───┐
    | (Write 2 to address 2027 in GP memory)
    └───┬───┘ [ MOV K3 D123 ]───┐
    | (Write 3 to address 2028 in GP memory)
    └───┬───┘ [ MOV K4 D124 ]───┐
    | (Write 4 to address 2029 in GP memory)
    └───┬───┘ [ MOV K5 D125 ]───┐
    | (Write 5 to address 2030 in GP memory)
    └───┬───┘ [ MOV K6 D126 ]───┐
    | (Write 6 to address 2031 in GP memory)
    └───┬───┘ [ MOV K1 D149 ]───┐
    |
    └───┬───┘ [ TO H0 H1E0 D119 K8 ]───┐
    | ( Saves the above settings to buffer memory)
    └───┬───┘ [ TO H0 H163 D149 K1 ]───┐
    (Display Request Flag ON)
  
```

■ Random Write Command

Address	Contents
RWwm (H)	5: Random Write
RWwm (L)	1-7: No. of Words (W/4 occupied nodes: max. 7 points, w/3 occupied nodes: max. 5 points, w/2 occupied nodes: max. 3 points)
RWwm +1	0 to 2031: GP System Area's designated address
RWwm +2	Write data
-	
RWwm +D	0 to 2031: GP System Area's designated address
RWwm +E	Write data
RWwm +F	Cannot be used
RWrn to RWrn +3	Cannot be used



Data cannot be written to the Link area.

< Sequence Program Example > (For random writing to address 0, 1100 and 1979 in GP memory. This example uses Write data 1,2, and 3.)

X6 (Data Link normal startup completed using buffer memory's parameter)

```

— | |————— [ SET M 1 1 0 ] —
M110
— | |————— [ MOV K 1 2 8 3 D 1 1 9 ] —

| (Designates 5 : Random Write(H), and 3 : no. of points(L) )
— | |————— [ MOV K 0 D 1 2 0 ] —
| (Designates address 0 in GP memory)
— | |————— [ MOV K 1 D 1 2 1 ] —
| (Write 1 to address 0 in GP memory)
— | |————— [ MOV K 1 1 0 0 D 1 2 2 ] —
| (Designates address 1100 in GP memory)
— | |————— [ MOV K 2 D 1 2 3 ] —
| (Write 2 to address 1100 in GP memory)
— | |————— [ MOV K 1 9 7 9 D 1 2 4 ] —
| (Designates address 1979 in GP memory)
— | |————— [ MOV K 3 D 1 2 5 ] —
| (Write 3 to address 1979 in GP memory)
— | |————— [ T O H 0 H 1 E 0 D 1 1 9 K 7 ] —
| ( Saves above settings to buffer memory)
— | |————— [ MOV K 1 D 1 4 9 ] —
|
— | |————— [ T O H 0 H 1 6 3 D 1 4 9 K 1 ] —
      (Display Request Flag ON)
    
```

■ Register Monitor Command

Address	Contents
RWwm (H)	6: Register Monitor
RWwm (L)	1-14: No. of Words (W/4 occupied nodes: max. 14 points, w/3 occupied nodes: max. 10 points, w/2 occupied nodes: max. 6 points)
RWwm +1 to RWwm +F	0 to 2031: GP System Area's designated address
RWrn to RWrn +F	Cannot be used

< Sequence Program Example > (When setting GP memory addresses 0, 100, 200, 1000, 1500 and 2031 for Register Monitor)

X6 (Data Link normal startup completed using buffer memory's parameter)

```

— | | ————— [ SET M110 ] —
M110
— | | ————— [ MOV H606 D119 ] —
|
| (Designates 6 : Register Monitor(H), and 6 : no. of points(L))
| ————— [ MOV K0 D120 ] —
| (Designates Address 0 in GP memory)
| ————— [ MOV K100 D121 ] —
| (Designates Address 100 in GP memory)
| ————— [ MOV K200 D122 ] —
| (Designates Address 200 in GP memory)
| ————— [ MOV K1000 D123 ] —
| (Designates Address 1000 in GP memory)
| ————— [ MOV K1500 D124 ] —
| (Designates Address 1500 in GP memory)
| ————— [ MOV K2031 D125 ] —
| (Designates Address 2031 in GP memory)
| ————— [ TO H0 H1E0 D119 K7 ] —
| (Saves above settings in buffer memory)
| ————— [ MOV K1 D149 ] —
|
| ————— [ MOV K2 D148 ] —
|
| ————— [ TO H0 H163 D149 K1 ] —
| (Display Request Flag ON)
| ————— [ FROM H0 H2E0 D229 K6 ] —
| (Saves values stored in 6 word units from D229)
M9036 (Normally ON)
— | | ————— [ FROM H0 HE3 D1000 K1 ] —
| (Saves Display Completed Flag to D1000)
• When using Monitor Request Flag (during Monitoring) refer to the Sequence Program
  Example below.
— [ = K2049 D1000 ] ————— [ TO H0 H163 D148 K1 ] —
  ( When Display Complete Flag is ON) (Display Monitor Request Flag ON)

```

■ Register Periodic Write Command

Address	Contents
RWwm (H)	8: Register Periodic Write
RWwm (L)	1-7: No. of Words (W/4 occupied nodes: max. 7 points, w/3 occupied nodes: max. 5 points, w/2 occupied nodes: max. 3 points)
RWwm +1 to RWwm +F	0 to 2031: GP System Area's designated address
RWrn to RWrn +F	Cannot be used



Data cannot be written to the Link area.

< Sequence Program Example > (When setting addresses 0, 1100 and 2031 in GP memory as Register Periodic Write)

```

— [ = K 0 D 1 0 0 0 ] ————— [ M O V   K 2 0 5 1 D 1 1 9 ] ———
|   (Designates 8 : Register Periodic Write(H), and 3 : no. of points(L) )
|   ————— [ M O V   K 0 D 1 2 0 ] ———
|   (Designate address 0 in GP memory)
|   ————— [ M O V   K 1 1 0 0 D 1 2 1 ] —
|   (Designate address 1100 in GP memory)
|   ————— [ M O V   K 2 0 3 1 D 1 2 2 ] —
|   (Designate address 2031 in GP memory)
|   ————— [ T O H 0 H 1 E 0 D 1 1 9 K 4 ] ———
|   ( Saves above settings in buffer memory)
|   ————— [ M O V   K 1 D 1 4 9 ] ———
|
|   ————— [ M O V   K 4 D 1 4 8 ] ———
|
|   ————— [ T O H 0 H 1 6 3 D 1 4 9 K 1 ] —
|   (Display Request Flag ON)

M 9 0 3 6 (Normally ON)
— | | ————— [ F R O M H 0 H E 3 D 1 0 0 0 K 1 ] ———
|   (Saves buffer contents <Display Complete Flag> to D1000)

— [ = K 2 0 4 9 D 1 0 0 0 ] ————— [ T O H 0 H 1 6 3 D 1 4 8 K 1 ] —
|   ( When Display Complete Flag is ON)   (Display Periodic Write Request Flag ON)

M 9 0 3 6 (Normally ON)
— | | ————— [ T O H 0 H 1 E 0 D 1 1 9 K 1 ] —
|   (Data will be written in periodically when a value is input to D119)
    
```



For further information about the ladder program and settings, please refer to Mitsubishi’s “AJ61BT11/A1SJ61BT11 type CC-Link System Master Local Unit Users Manual (Details)” or “AJ61QBT11/A1SJ61QBT11 type CC-Link System Master Local Unit Users Manual (Details)”

9.2.5 Occupied Node

■ 2 Nodes Occupied

LS area (Word Address)	Bit	Signal	Detail	
a to a+2	0 to F	RXm0 to RX mF to RX (m+2)0 to RX (m+2)F	User's Area (RX) : 3words occupied (When 2 nodes are occupied)	
0 19 a a+7 a+8 a+51 a+52 2031	a+3	0	RX(m+n)0	Display Complete Flag
		1	RX(m+n)1	Reserved
		2	RX(m+n)2	Reserved
		3	RX(m+n)3	Reserved
		4	RX(m+n)4	Reserved
		5	RX(m+n)5	Touch ON Complete Flag
		6	RX(m+n)6	Reserved
		7	RX(m+n)7	Tag Code Read Out Request Flag
		8	RX(m+n)8	Reserved
		9	RX(m+n)9	Initial Data Setting Completed Flag
		10	RX(m+n)A	Error Flag
		11	RX(m+n)B	Remote READY
		12	RX(m+n)C	Reserved
		13	RX(m+n)D	Reserved
		14	RX(m+n)E	Reserved
		15	RX(m+n)F	Reserved
a+4 to a+7		Not used		
a+8		Reserved		
a+9		Reserved		
a+10 to a+12	0 to F	RYm0 to RY mF to RY (m+2)0 to RY (m+2)F	User's Area (RY) : 3words occupied (When 2 nodes are occupied)	
0 19 a a+7 a+8 a+51 a+52 2031	a+13	0	RY(m+n)0	Display Request Flag
		1	RY(m+n)1	Display Monitor Request Flag
		2	RY(m+n)2	Display Periodic Write Request Flag
		3	RY(m+n)3	Reserved
		4	RY(m+n)4	Reserved
		5	RY(m+n)5	Reserved
		6	RY(m+n)6	Reserved
		7	RY(m+n)7	Reserved
		8	RY(m+n)8	Reserved
		9	RY(m+n)9	Initial Data Setting Request Flag
		10	RY(m+n)A	Error Reset Request Flag
		11	RY(m+n)B	Reserved
		12	RY(m+n)C	Reserved
		13	RY(m+n)D	Reserved
		14	RY(m+n)E	Reserved
		15	RY(m+n)F	Reserved
a+14 to a+17		Not used		
a+18		Reserved		
a+19		Reserved		
a+20 to a+27		Rwr	Rwr (R to M) during ordinary monitoring	
a+28 to a+35		Not used		
a+36 to a+43		RWw	RWw (M to R) during ordinary monitoring	
a+44 to a+51		Not used		



- Shaded areas are used when 2 to 4 nodes are used on common.
- “a” means a Start Address.(a³ 20)
- “System area” is used for writing GP display switching data/ error data. The type of data written is defined in each address. The contents of this area are the same as the Memory Link Type. **Reference** Refer to 3.1.2 Contents and Range of System Data Area.

■ 3 Nodes Occupied

		LS area (Word Device)	Bit	Signal	Contents
0 19 a a7 a8 a+51 a+52 2031	System Data Area	a to a+4	0 to F	RXm0 to RX mF to RX (m+4)0 to RX (m+4)F	User's Area (RX) : 5 words occupied (When 3 nodes are occupied)
		Link Area (a to a+7)	a+5	0	RX(m+n)0
	1		RX(m+n)1	Reserved	
	2		RX(m+n)2	Reserved	
	3		RX(m+n)3	Reserved	
	4		RX(m+n)4	Reserved	
	5		RX(m+n)5	Touch ON Complete Flag	
	6		RX(m+n)6	Reserved	
	7		RX(m+n)7	Tag Code Read Out Request Flag	
	8		RX(m+n)8	Reserved	
	9		RX(m+n)9	Initial Data Setting Completed Flag	
	10		RX(m+n)A	Error Flag	
	11		RX(m+n)B	Remote READY	
	12		RX(m+n)C	Reserved	
	13		RX(m+n)D	Reserved	
	14		RX(m+n)E	Reserved	
15	RX(m+n)F	Reserved			
	Link Area (a+8 ~ a+51)	a+6 to a+7		Not used	
	User Area (a+52 ~ 2031)	a+8		Reserved	
		a+9		Reserved	
		a+10 to a+14	0 to F	RYm0 to RY mF to RY (m+4)0 to RY (m+4)F	User's Area (RY) : 5 words occupied (When 3 nodes are occupied)
	Link Area (a+52 ~ 2031)	a+15	0	RX(m+n)0	Display Request Flag
			1	RX(m+n)1	Display Monitor Request Flag
			2	RX(m+n)2	Display Periodic Write Request Flag
			3	RX(m+n)3	Reserved
			4	RX(m+n)4	Reserved
			5	RX(m+n)5	Reserved
			6	RX(m+n)6	Reserved
			7	RX(m+n)7	Reserved
			8	RX(m+n)8	Reserved
			9	RX(m+n)9	Initial Data Setting Request Flag
			10	RX(m+n)A	Error Reset Request Flag
			11	RX(m+n)B	Reserved
			12	RX(m+n)C	Reserved
			13	RX(m+n)D	Reserved
			14	RX(m+n)E	Reserved
			15	RX(m+n)F	Reserved
		a+16 to a+17		Not used	
		a+18		Reserved	
		a+19		Reserved	
		a+20 to a+31		RW r	Rw r (R to M) during ordinary monitoring
		a+32 to a+35		Not used	
		a+36 to a+47		RWw	RWw (M to R) during ordinary monitoring
		a+48 to a+51		Not used	



- Shaded areas are used when 2 to 4 nodes are used on common.
- “a” means a Start Address.(a³ 20)
- “System area” is used for writing GP display switching data/ error data. The type of data written is defined in each address. The contents of this area are the same as the Memory Link Type. **Reference** Refer to 3.1.2 Contents and Range of System Data Area.

■ 4 Nodes Occupied

LS area (Word Device)	Bit	Signal	Contents	
<div style="display: flex; flex-direction: column; align-items: center;"> <div style="border: 1px solid black; padding: 2px; margin-bottom: 2px;">0 System Data Area</div> <div style="border: 1px solid black; padding: 2px; margin-bottom: 2px;">19 a Link Area (a to a+7)</div> <div style="border: 1px solid black; padding: 2px; margin-bottom: 2px;">a+7 a+8 Link Area (a+8 ~ a+51)</div> <div style="border: 1px solid black; padding: 2px;">a+51 a+52 User Area (a+52 ~ 2031)</div> <div style="margin-top: 20px;">2031</div> </div>	a to a+6	0 to F	RXm0 to RX mF to RX (m+6)0 to RX (m+6)F	User's Area (RX) : 7 words occupied (When 4 nodes are occupied)
	a+7	0	RX(m+n)0	Display Complete Flag
		1	RX(m+n)1	Reserved
		2	RX(m+n)2	Reserved
		3	RX(m+n)3	Reserved
		4	RX(m+n)4	Reserved
		5	RX(m+n)5	Touch ON Complete Flag
		6	RX(m+n)6	Reserved
		7	RX(m+n)7	Tag Code Read Out Request Flag
		8	RX(m+n)8	Reserved
		9	RX(m+n)9	Initial Data Setting Completed Flag
		10	RX(m+n)A	Error Flag
		11	RX(m+n)B	Remote READY
		12	RX(m+n)C	Reserved
		13	RX(m+n)D	Reserved
		14	RX(m+n)E	Reserved
	15	RX(m+n)F	Reserved	
a+8			Reserved	
a+9			Reserved	
a+10 to a+16	0 to F	RYm0 to RY mF to RY (m+6)0 to RY (m+6)F	User's Area (RY) : 7 words occupied (When 4 nodes are occupied)	
a+17	0	RX(m+n)0	Display Request Flag	
	1	RX(m+n)1	Display Monitor Request Flag	
	2	RX(m+n)2	Display Periodic Write Request Flag	
	3	RX(m+n)3	Reserved	
	4	RX(m+n)4	Reserved	
	5	RX(m+n)5	Reserved	
	6	RX(m+n)6	Reserved	
	7	RX(m+n)7	Reserved	
	8	RX(m+n)8	Reserved	
	9	RX(m+n)9	Initial Data Setting Request Flag	
	10	RX(m+n)A	Error Reset Request Flag	
	11	RX(m+n)B	Reserved	
	12	RX(m+n)C	Reserved	
	13	RX(m+n)D	Reserved	
	14	RX(m+n)E	Reserved	
	15	RX(m+n)F	Reserved	
a+18			Reserved	
a+19			Reserved	
a+20 to a+35		RWr	Rwr (R to M) during ordinary monitoring	
a+36 to a+51		RWw	RWw (M to R) during ordinary monitoring	



- Shaded areas are used when 2 to 4 nodes are used on common.
- “a” means a Start Address.(a³ 20)
- “System area” is used for writing GP display switching data/ error data. The type of data written is defined in each address. The contents of this area are the same as the Memory Link Type. **Reference** Refer to 3.1.2 Contents and Range of System Data Area.

9.2.6 Error Code

The following list shows the error codes used with CC-Link. These error codes will appear on the screen as, for example, “ PLC COM. ERROR, (02: **)”, where ** stands for an error code listed below.

Error Code (**)	Error Details
01	Designated device point is not within the limited range
02	Designated address is not within the limited range
03	Command is not defined
04	Incorrect initial command is designated.(Do not use the Request Flag for initial
05	Undefined mode is designated for initial command
06	Not registered in Monitor Command
07	Not registered in Periodic Write Command
08	Data attempted to be written in the write prohibited system area
09	In the OFFLINE mode now
14	No Reply from Hardware
15	Problem in Hardware
16	Node Number switch setting error
17	Baud Rate Switch setting error
18	Set up Node Number switch change error
19	Set up Baud Rate switch change error
1A	CRC error
1B	Time over error
1C	0 channel carrier detection error
1D	1 channel carrier detection error
1E	Communication Transfer error
1F	Y data or RWw data, numerical error
20	Y data, numerical error
21	RWw data, numerical error



If a command error occurs while exclusive command monitor is used, the GP will automatically set the error codes above in RWr, then turn ON the Error Status Flag “RX(m+n)A” and the Display Complete Flag “RX(m+n)0” .

◆ Troubleshooting





GP Error Display (bottom left corner)	Status
PLC COM.ERROR (02:14)	PLC's power supply turned off during normal communication
PLC COM.ERROR (02:14)	Cable between PLC and GP is not properly connected
PLC COM.ERROR (02:15)	GP's rear unit is not attached
PLC COM.ERROR (02:15)	GP's rear unit is not properly attached
PLC COM.ERROR (02:14)	GP is not registered in the current parameters.
PLC COM.ERROR (02:14)	Baud Rate is not applicable
PLC COM.ERROR (02:14)	Node number is duplicated.
PLC COM.ERROR (02:1A) Blinking	Terminating resistor is not connected

9.3 Intelligent Device Station



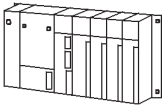

9.3.1 System Configuration

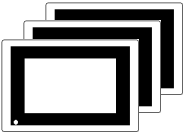
This section shows system configurations used when connecting Mitsubishi Electric PLCs and GP.

■ MELSEC-A Series

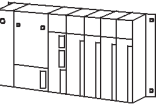

CPU	Link I/F	Cable Diagram	Cables	Unit	GP
					
A1S, A1SH, A1SJ, A1SJH, A1SCPUC24-R2, A2S, A2SH, A2US, A2US-S1, A2USH-S1	A1SJ61BT11	RS-485 <Cable Diagram 1>	Kurashige Denko's Twisted pair cable with shield Model: FANC-SB 0.5 mm ² × 3 or FANC-SBH 0.5 mm ² × 3 or FANC-SB110H	CC-Link unit (MFP1) model: GP077R-CL11	GP Series *1
A0J2H, A1N, A2N, A2N-S1, A3N, A3M, A3H, A2A, A2A-S1, A3A, A2U, A2U-S1, A3U, A4U	AJ61BT11				

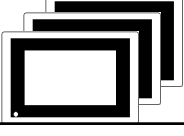
■ MELSEC-QnA Series

CPU	Link I/F	Cable Diagram	Cables	Unit	GP
					
Q2AS Q2ASH	A1SJ61QBT11	RS-485 <Cable Diagram 1>	Kurashige Denko's Twisted pair cable with shield Model: FANC-SB 0.5 mm ² × 3 or FANC-SBH 0.5 mm ² × 3 or FANC-SB110H	CC-Link unit (MFP1) model: GP077R-CL11	GP Series *1
Q2A Q2A-S1 Q3A Q4A Q4AR	AJ61QBT11				

*1 Applicable GP series is GP-377RT, GP-477RE, and GP-577RS. For GP-477RE, GP-577RT, and GP-577RS, however, a GLC bus conversion unit (GLC300-BCB41) is required.

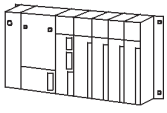
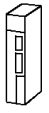
■ MELSEC-A Series

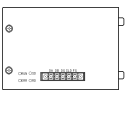
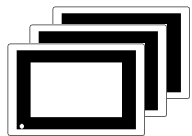
CPU	Link I/F	Cable Diagram	Cables	Unit	GP
					
Q02CPU Q02HCPU Q06HCPU Q12HCPU Q25HCPU	QJ61BT11	RS-485 <Cable Diagram 1>	Kurashige Denko's Twisted pair cable with shield Model: FANC-SB 0.5 mm ² × 3 or FANC-SBH	CC-Link unit (MFP1) model: GP077R-CL11	GP Series *1
Q02CPU-A Q02HCPU-A Q06HCPUA-A	A1SJ61BT11		0.5 mm ² × 3 or FANC-SB110H		

*1. Applicable GP series is GP-377RT, GP-477RE, GP-577RT, and GP-577RS.
For GP-477RE, GP-577RT, and GP-577RS, however, a GLC bus conversion unit (GLC300-BCB41) is required.

■ Network Connection Example

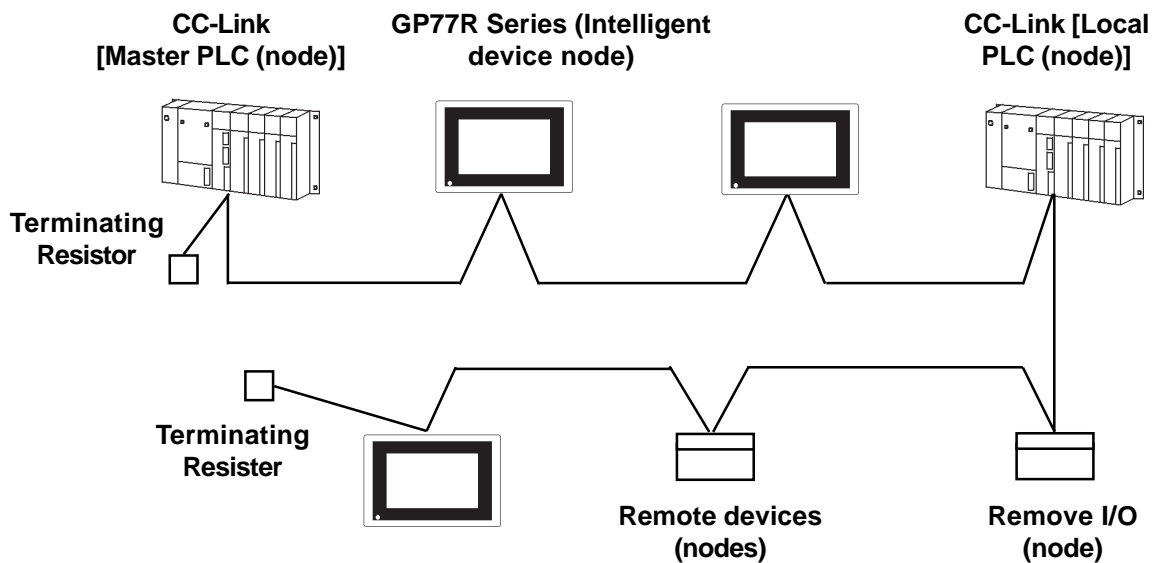

◆ **Number of Connectable Units**

All GP units connected to the master PLC (node) have the following operation conditions:

$$1. \{(1 \times a) + (2 \times b) + (3 \times c) + (4 \times d)\} \leq 64$$

a: Number of units occupying 1 node

b: Number of units occupying 2 nodes

c: Number of units occupying 3 nodes

d: Number of units occupying 4 nodes

$$2. \{(16 \times A) + (54 \times B) + (88 \times C)\} \leq 2304$$

A: Number of remote I/O nodes ≤ 64

B: Number of remote device nodes ≤ 42

C: Number of local and intelligent device nodes ≤ 26

◆ **Maximum number of connectable GPs**

The GP will become an intelligent device node. Also, the minimum number of occupying nodes is 1. As a result, the number of GPs that can be connected to a single master node is 26.



For more detailed information about master node system design, refer to the following manuals' system design chapter:

Mitsubishi Electric:

- **AJ61BT11/A1SJ61BT11 Unit CC-Link System Master and Local Unit User's Manual (Details)**
- **AJ61QBT11/A1SJ61QBT11 Unit CC-Link System Master and Local Unit User's Manual (Details)**
- **QJ61BT11 Unit CC-Link System Master and Local Unit User's Manual (Details)**

9.3.2 Cable Diagram

Although the cable diagram shown below and those recommended by the Mitsubishi Electric Corp. may differ, using these cables for connection will not cause any problems.

Recommended Cables

The recommended cables are as follows:

CC-Link cable: Kurashige Denko FANC-SB 0.5 mm² X 3

CC-Link High cable: Kurashige Denko FANC-SBH 0.5 mm² X 3

CC-Link cable (New Type): Kurashige Denko FANC-SB110H



- **Be sure to use only CC-Link cables.**
- **CC-Link cables and CC-Link high performance cable, cannot be used simultaneously.**
- **For details about T-junction connections, refer to Mitsubishi Electric CC-Link Master Unit Manual.*1**

*1 Mitsubishi Electric manuals:

- AJ61BT11/A1SJ61BT11 Unit CC-Link System Master and Local Unit User's Manual (Details)
- AJ61QBT11/A1SJ61QBT11 Unit CC-Link System Master and Local Unit User's Manual (Details)
- QJ61BT11 Unit CC-Link System Master and Local Unit User's Manual (Details)

Cable Diagram 1 (RS-485)

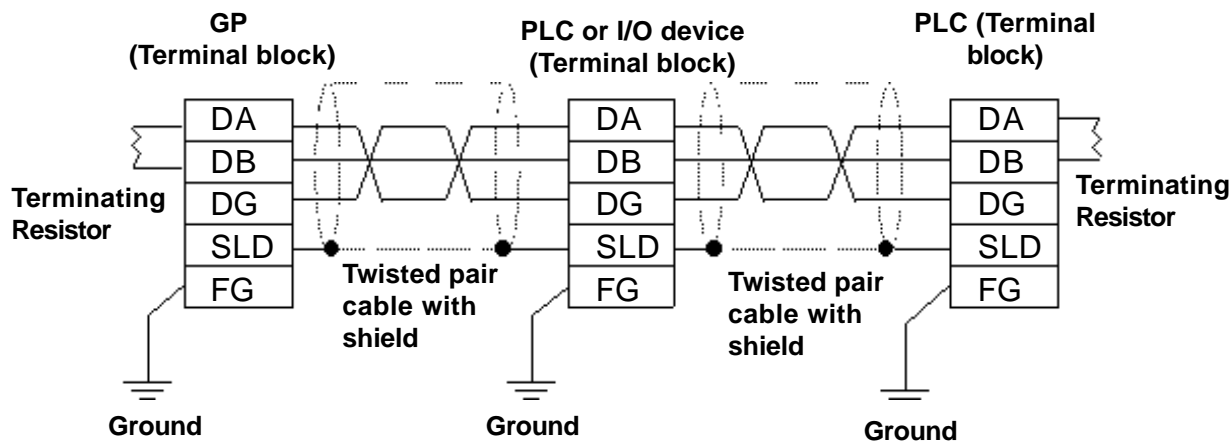



- Connect the shield wires to each unit’s SLD terminal.
The SLD terminal is connected internally be connected to the FG terminal. Use a grounding method applicable to your area’s regulations and laws.
- Insert the Master Unit’s terminating resistor at both ends of the data link (between DA and DB). Be aware that terminating resistance value of the CC-Link cable will differ from that of the CC-Link high performance cable.
- For more detailed information about terminating resistance values and cable lengths, refer to Mitsubishi Electric CC-Link Master Unit Manual.*1

9.3.3 Supported Devices

The following lists show the range of devices supported by the GP.



Each device’s address range may differ depending on your CPU model. For each CPU device range, refer to Mitsubishi Electric PLC manuals.

**■ MELSEC-A/QnA/Q Series
(Common for All Series Units) (Cyclic Transmission)**

Device	Bit Address	Word Address	Particulars
Remote input	RX000 ~ RX7FF	RX000 ~ RX7F0	<input type="checkbox"/> *** 0 ^{*1}
Remote output	RY000 ~ RY7FF	RY000 ~ RY7F0	<input type="checkbox"/> *** 0 ^{*1}
Remote resistor	RWw000 ~ RWwFFF	RWw00 ~ RWwFF	
Remote resistor	RWr000 ~ RWrFFF	RWr00 ~ RWrFF	^{*1}









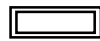







L/H

**1 Data cannot be written from the GP. Only data read can be performed.
“RX”, “RY”, “RWx”, and “RWw” are the names used on the GP. On the master node, these assigned names will become opposite.*

	Assigned Name			
GP	RX	RY	RWw	RWr
PLC	RY	RX	RWr	RWw

■ MELSEC-A Series (Transient transmission)

 Setup System Area or Communication Information's Storing Address here.

Device	Bit Address	Word Address	Particulars	
Input relay	X0000 ~ X1FFF	X0000 ~ X1FF0		L/H
Output relay	Y0000 ~ Y1FFF	Y0000 ~ Y1FF0		
Internal relay	M0000 ~ M8191	M0000 ~ M8191		
Special relay	M9_000 ~ M9_255	M9_000 ~ M9_240	 *1	
Retain relay	L0000 ~ L8191	L0000 ~ L8176		
Link relay	B0000 ~ B1FFF	B0000 ~ B1FF0		
Timer (contact)	TS0000 ~ TS2047	TS0000 ~ TS2032		
Timer (coil)	TC0000 ~ TC2047	TC0000 ~ TC2032		
Counter (contact)	CS0000 ~ CS1023	CS0000 ~ CS1008		
Counter (coil)	CC0000 ~ CC1023	CC0000 ~ CC1008		
Timer (current value)	-----	TN00000 ~ TN2047		
Counter (current value)	-----	CN0000 ~ CN1023		
Data register	-----	D0000 ~ D8191		
Special register	-----	D9_000 ~ D9_255	 *2	
Link register	-----	W0000 ~ W1FFF		
File register	-----	R0000 ~ R8191		

*1 When designating special relay devices, select "M9_" in the screen editor.

*2 When designating special register devices, select "D9_" in the screen editor.

























Annunciator devices are inaccessible.

E-tag or K-tag indirect addresses cannot be designated.

■ MELSEC-QnA/Q Series (Transient transmission)

 Setup System Area or Communication Information's Storing Address here.

Device	Bit Address	Word Address	Particulars	
Input relay	X0000 ~ X1FFF	X0000 ~ X1FF0		L/H
Output relay	Y0000 ~ Y1FFF	Y0000 ~ Y1FF0		
Internal relay	M0000 ~ M32767	M0000 ~ M32752		
Special relay	SM0000 ~ SM2047	SM0000 ~ SM2032		
Latch relay	L0000 ~ L32767	L0000 ~ L32752		
Link relay	B0000 ~ B7FFF	B0000 ~ B7FF0		
Special link relay	SB000 ~ SB7FF	SB000 ~ SB7F0		
Timer (contact)	TS00000 ~ TS23087	TS00000 ~ TS23072		
Timer (coil)	TC00000 ~ TC23087	TC00000 ~ TC23072		
Totaling timer (contact)	SS00000 ~ SS23087	SS00000 ~ SS23072		
Totaling timer (coil)	SC00000 ~ SC23087	SC00000 ~ SC23072		
Counter (contact)	CS00000 ~ CS23087	CS00000 ~ CS23072		
Counter (coil)	CC00000 ~ CC23087	CC00000 ~ CC23072		
Timer (current value)	-----	TN00000 ~ TN23087		
Totaling timer (current value)	-----	SN00000 ~ SN23087		
Counter (current value)	-----	CN00000 ~ CN23087		
Data register	-----	D00000 ~ D25983		
Special register	-----	SD0000 ~ SD2047		
Link register	-----	W0000 ~ W657F		
Special link register	-----	SW000 ~ SW7FF		
File register	-----	R0000 ~ R32767		

 **Note:** Annunciator, Edge relay, and Step relay devices are not accessible.
E-tag or K-tag indirect addresses cannot be designated.

■ Device Addresses and Nodes Connection Limitations

When a CC-Link intelligent node accesses PLC devices in the master or local node memory, due to the GP's internal restrictions, the following limitations apply.

◆ Limitations

When a block's size limit (1024: 1K) is exceeded, or a different node's device address is used, GP unit internal records are used to set device addresses. These records are limited to 64.

For example, when the D0 device address is set, a single record is used in the GP. For detailed examples, refer to the following chart.

E.x. 1)

Number of records used when performing the following tag settings:

Setting No.	Setting Node No.	Device Address	Remaining Number of Records in GP-PRO/PB III	Remarks
1	1	D0	63	Uses one record
2	1	D1024	62	Uses one record
3	2	D0	61	Uses one record
4	2	D1024	60	Uses one record
5	2	R0	60	Since the node number and address range already exist as setting No. 3, no records will be used.
6	2	R1024	60	Since the node number and address range already exist as setting No. 4, no records will be used.
7	2	D2048	59	Uses one record
8	3	D2048	58	Uses one record
9	3	D2049	58	Since the node number and address range already exist as setting No. 8, no records will be used.

Also, if a different node number is used, or the size of an address exceeds the block limit of 1024 (1KB), a GP internal record is used. However, if only the device name is changed, or if the new address range used is the same size as the previously set range, a record will not need to be used.

Ex. 2)

When setting data register up to D16384 as well as setting addresses in a block (1024: 1K) via tag settings, 16 internal records will be used.

$$16384 \div 1024 = 16$$

Therefore, when performing the same amount of tag settings for each node, settings can be performed for only a total of 4 nodes.

* When the number of internal records exceeds 64, the following error message will appear on the GP screen editor software:

“The number of device addresses has exceeded the upper limit. Cannot perform any more settings.

<Cyclic Transmission>

All remote input/output and remote register data that has been allocated to the master node via the CC-Link parameter settings, can be read.

From this data, only RX and RWr allocated to the GP via the master node can be written from the GP. (These names will become RY and RWw on the GP.)

■ Number of Bits Allocable to the GP

Device	Number of Nodes Occupied		Remark
	1 Node	4 Nodes	
Remote input (RX)	32 bits	128 bits	No. of bits
Remote output (RY)	32 bits	128 bits	No. of bits
Remote register (RWr)	4 words	16 words	No. of word
Remote register (RWw)	4 words	16 words	No. of word

■ Remote Input/Output Signals (Individual to Master Nodes)

The following data explains the GP’s individual node input/output signal allocation. There are two signal allocation, methods: using or not using remote READY flag or not using it. Also, the input/output signal will vary depending on the set number of occupying nodes (1 node/4 nodes).

◆ When remote READY flag (default) is not used:

The “n” character used in the following table reflects the address number used for each node by the master node.

Signal Direction: GP -> Master Node			Signal Direction: Master Node -> GP		
Device No.		Signal Name	Device No.		Signal Name
Number of Occupying Nodes			Number of Occupying Nodes		
1 Node	4 Nodes		1 Node	4 Nodes	
RYn0 ~ RYnF	RYn0 ~ RY(n+6)F	User area	RXn0 ~ RXnF	RXn0 ~ RX(n+6)F	User area
RY(n+1)0 ~ RY(n+1)C	RY(n+7)0 ~ RY(n+7)C		RX(n+1)0 ~ RX(n+1)C	RX(n+7)0 ~ RX(n+7)C	
RY(n+1)E ~ RY(n+1)F	RY(n+7)E ~ RY(n+7)F	Prohibited to use *1	RX(n+1)E ~ RX(n+1)F	RX(n+7)E ~ RX(n+7)F	Prohibited to use *1

*1 The last 2 bits cannot be used for any node settings.

◆ **When using remote READY flag (default):**

The “n” character used in the following table reflects the address number used for each node by the master node.

Signal Direction: GP -> Master Node			Signal Direction: Master Node -> GP		
Device No.		Signal Name	Device No.		Signal Name
Number of Occupying Nodes			Number of Occupying Nodes		
1 Node	4 Nodes		1 Node	4 Nodes	
RYn0 ~ RYnF	RYn0 ~ RY(n+6)F	User area	RXn0 ~ RXnF	RXn0 ~ RX(n+6)F	User area
RY(n+1)0 ~ RY(n+1)A	RY(n+7)0 ~ RY(n+7)A	Prohibited to use	RX(n+1)0 ~ RX(n+1)A	RX(n+7)0 ~ RX(n+7)A	Prohibited to use
RY(n+1)B	RY(n+7)B	Remote READY flag *1	RX(n+1)B	RX(n+7)B	
RY(n+1)C ~ RY(n+1)F	RY(n+7)C ~ RY(n+7)F	Prohibited to use	RX(n+1)C ~ RX(n+1)F	RX(n+7)C ~ RX(n+7)F	

*1 The remote READY flag will turn ON during GP start-up. When turning the GP’s power ON, when resetting the hardware, and when the GP is ready for operation, the remote READY flag will turn ON. Even while the GP’s power is ON, the remote READY flag will turn OFF during offline operation and while performing initial processing. Use this feature for the interlock circuit used when reading and writing data from the CC-Link master node.

■ **Relationship between Master and Individual Nodes**

The following data explains the GP’s remote register allocation.

The remote register will vary depending on the number of occupying nodes (1 node/ 4 nodes) set.

The “m” and “n” characters used in the following table reflect the address numbers used for each node by the master node.

Data Direction	Address		Area
	Number of Occupying Nodes		
	1 Node	4 Nodes	
GP -> Master node	RWwm ~ RWwm+3	RWwm ~ RWwm+F	Data write area
Master node -> GP	RWrn ~ RWrn+3	RWrn ~ RWrn+F	Data read area

■ Remote Enput Allocation via Master Node

Data can be written from the GP to these areas.

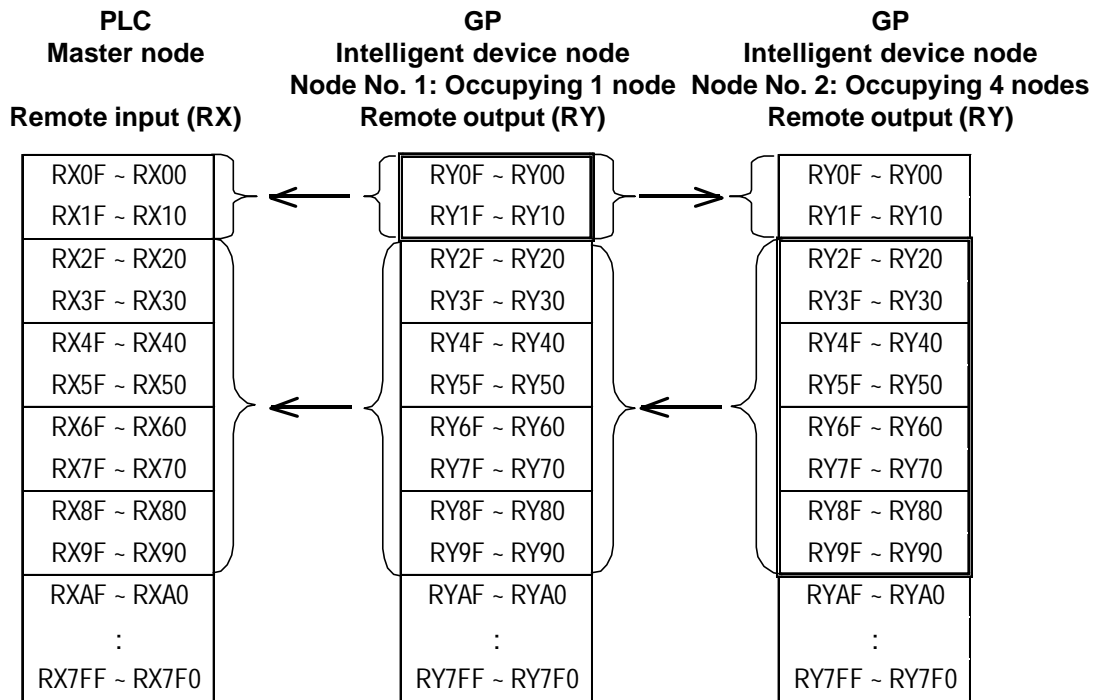

■ Remote Output Allocation via Master Node

Data can be written from the GP to these areas.

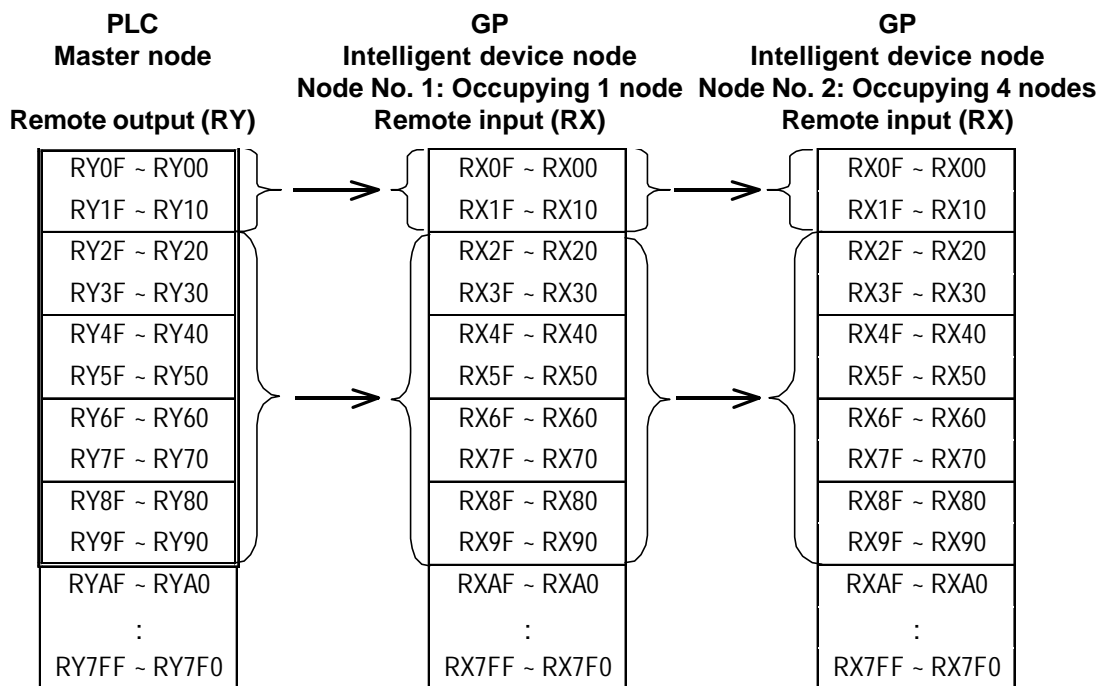

Remote Register (data read area) Allocation via Master Node

Data can be written from the GP to these areas.

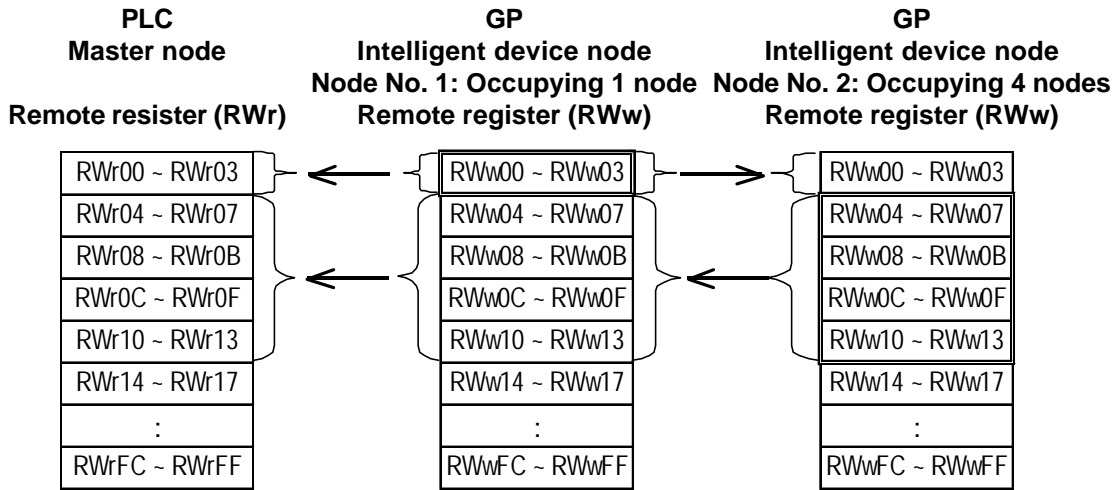

Remote Register (data write area) allocation via Master Node

Data can be written from the GP to these areas.

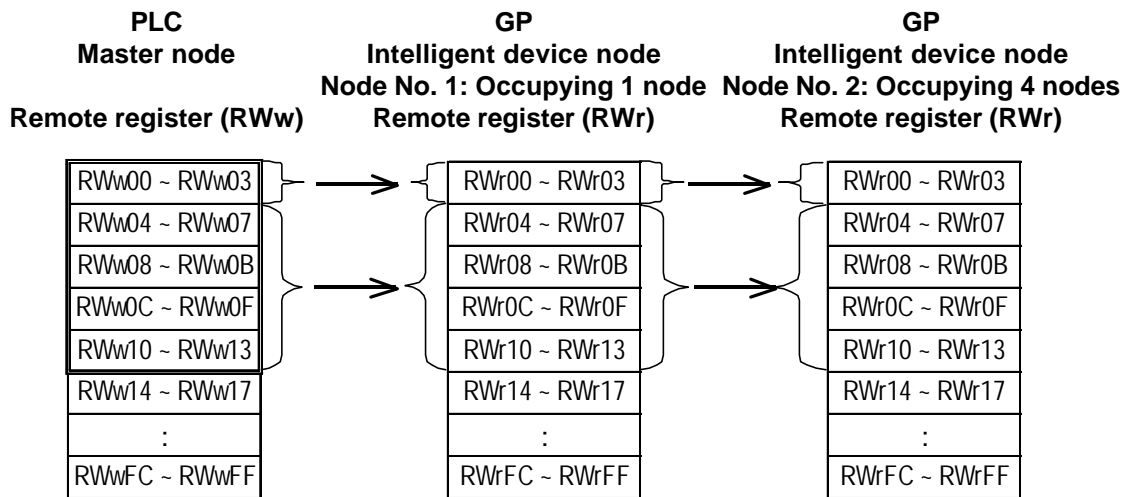



Note: When performing Part and tag settings via GP-PRO/PB III for Windows, designate the PLC node number at the same time as entering addresses. (The default value used when the software starts is “0”.)

When using cyclic transmission, node number settings are unnecessary.

Reference *Reference: For the devices on which cyclic transmission can be performed, refer to 9.3.3 Supported Devices, MELSEC-A/QnA/Q Series (Common for All Series Units) (Cyclic Transmission).*

<e.g.> When a device address is “X0000”:
Enter “X” for the device name, and “0000” for the address.

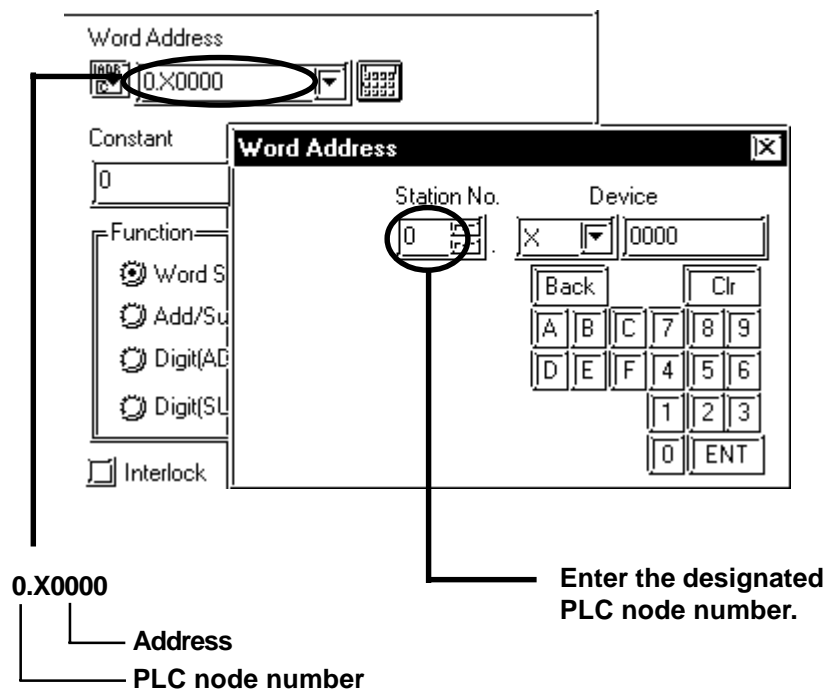
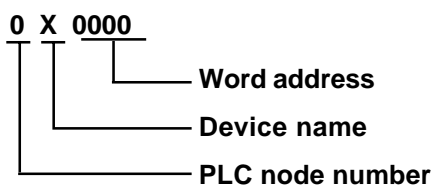

9.3.4 Environment Setup

The following table shows Digital’s recommended PLC and GP communication settings.

■ MELSEC-A/QnA/Q Series

GP Settings		PLC (Master Node CC-Link Unit) Settings	
Baud Rate	156kbps	Baud Rate Setting Switch	0 (156kbps)
No. of Occupiable Nodes	1	Node Information Settings	*1
Node No.	1	Node Information Settings	*1
Data Input Status	Clear	_____	_____
Remote READY flag	Not used	_____	_____
_____	_____	Node No. Setting Switch	0 (master)
_____	_____	Mode Setting Switch	0 (online)
_____	_____	Condition Setting Switch	All OFF

*1 The A Series requires a ladder program to enter the CC-Link settings.

Reference Refer to 9.3.4 Environment Setup, Sample Ladder

- The QnA/Q Series’ CC-Link settings are entered via entering the network parameter settings on the ladder program.
- For more detailed information about ladder program settings, refer to Mitsubishi Electric [AJ61BT11/A1SJ61BT11] Unit CC-Link System Master and Local Unit User’s Manual (Details), [AJ61QBT11/A1SJ61QBT11] Unit CC-Link System Master and Local Unit User’s Manual (Details), or [QJ61BT11] Unit CC-Link System Master and Local Unit User’s Manual (Details)’s [Parameter Settings] section.



- Be sure to set the master node number to “0”. (Use the rotary switch to set the master node unit’s node number setting switch.)
- To assign other nodes, the Mitsubishi ladder logic program’s the network parameter settings feature is required (CC-Link).

■ Sample Ladder Program

The following is a sample ladder used when performing communication via the structure shown below:

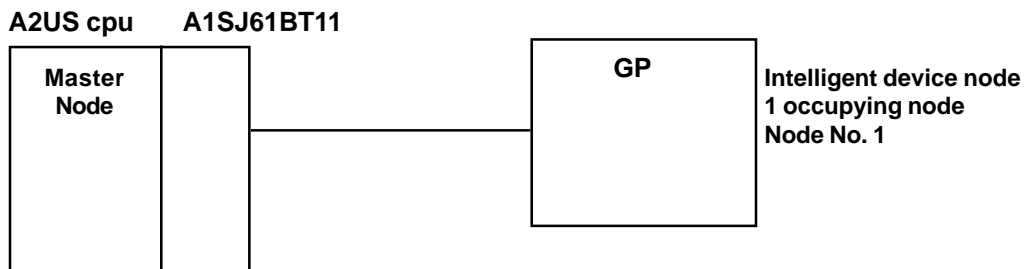

```

X0      X0F
---|/-----|----- [ PLS L300 ]---- X0: Unit problem XF: Unit ready
L300
---|-----|----- [ SET L301 ]---- Unit parameter setting command
L300
---|-----|----- [ MOV K1 D0 ]---- No. of units connected: 1
                                   (excluding the master node)
                                   [ MOV K7 D1 ]---- Retry frequency: 7
                                   [ MOV K1 D2 ]---- No. of Automatic return function: 1
                                   [ TO H0 H1 D0 K3 ]---- Stores D0 to D2 in buffer memory H1
                                   [ MOV K0 D3 ]---- Operation performed at CPU
                                   down: 0 ( stop )
                                   [ TO H0 H6 D3 K1 ]---- Stores D3 in buffer memory H6
                                   [ MOV H2101 D4 ]---- GP node type: 2 No. of occupying
                                   nodes: 1 Node No. : 1
                                   [ TO H0 H20 D4 K1 ]---- Stores D4 in buffer memory H20
                                   [ RST L301 ]---- Unit parameter settings completed
M9038
---|-----|----- [ SET Y0 ]---- Unit refresh command
X0      X0F
---|/-----|----- [ PLS L302 ]---- X0: Unit problem XF: Unit ready
L302
---|-----|----- [ SET L303 ]---- Data link activation command
L303
---|-----|----- [ SET Y6 ]---- Data link activation request
X6
---|-----|----- [ RST L303 ]---- Data link activation request flag OFF
                                   [ RST L303 ]---- Data link activation normally completed
X7
---|-----|----- [ FROM H0 H668 D50 K1 ]---- Error code read when data link activation
                                   is abnormally completed
                                   [ RST Y6 ]---- Data link activation normally request flag OFF
                                   [ RST L303 ]---- Data link activation abnormally completed
    
```

■ GP Settings

Enter the GP settings used for CC-Link communication, via the following screens. Use either GP screen editor software or GP offline menu to enter the number of occupying nodes, GP's node number, and baud rate.

◆ Operating Environment Menu

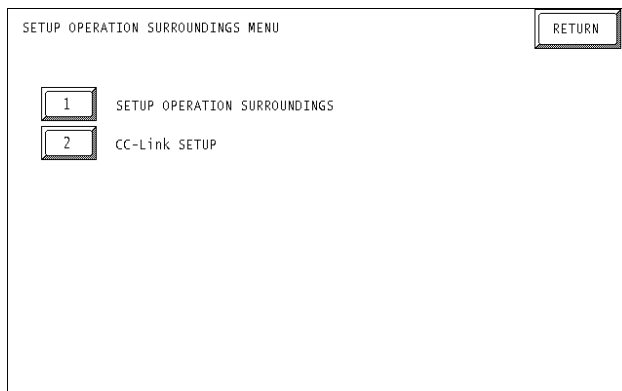

◆ Operating Environment Settings

Select [1 PLC SETUP] from the operating environment menu and enter each setting.

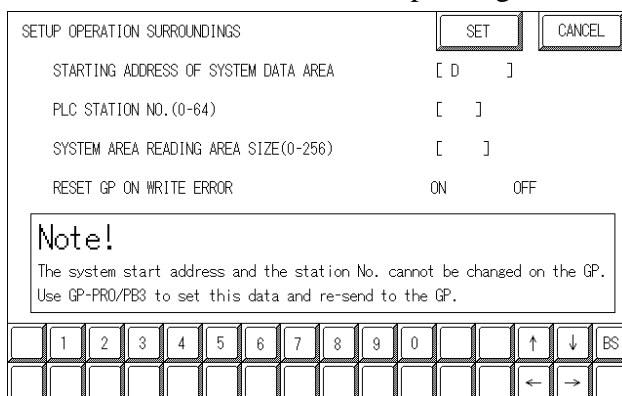

STARTING ADDRESS OF SYSTEM DATA AREA *1

the first address from which the system area begins to be allocated.

PLC Node No. (1 to 64) *1

the PLC node number to which the system area is allocated.

SYSTEM AREA READING AREA SIZE (0-256)

Enter the system area's reading area size.

RESET GP ON DATA WRITE ERROR

Select the data write operation status when a data write error occurs. (Applicable only for GP77R Series)

*1 This setting cannot be changed with GP's OFFLINE mode.

When changing the setting, perform with [GP System Setting] of GP-Pro/PB III.

◆ **CC-Link Settings**

Select [2 CC-Link SETUP] from the operating environment menu and enter each setting.

CC-Link SETUP		SET	CANCEL
NODE NUMBER TO OCCUPY(1 or 4)	1	4	
GP STATION NO.(1-64)	[]	
BAUD RATE(bps)	156k	625k	2.5M 5M 10M
INPUT DATA STATE ON DATA LINK ERROR	CLEAR	HOLD	
USE REMOTE READY FLAG	OFF	ON	

	1	2	3	4	5	6	7	8	9	0			↑	↓	BS
													←	→	

No. of Occupying Nodes (1 or 4)

Select the number of nodes that the GP occupies.

GP Node No. (1 to 64)

Enter the GP's node number.

Baud Rate (156 kbps to 10 Mbps)

Enter the communication baud rate.

Input Data Status Used for Abnormal data Link (Clear or Retained)

Enter the input data status used when a problem occurs on data link.

Remote READY Flag

Select if the remote READY flag is used.

For more detailed information about the remote READY flag **Reference** refer to 9.3.3 supported Device; Remote Input /Out put Signal from Individual to Master Nodes..

◆ **GP Screen Editor Software Settings**

Enter the necessary data via [GP System Settings][Mode Settings][Options].

The screenshot shows the 'GP Settings - new_project.PRW' dialog box with the 'Communication Settings' tab selected. The 'GP Settings' sub-tab is active, showing the following fields: PLC Type (CC-Link Intelligent Device), System Start Address (0.D0000), Machine Number (0), Read Area Size (0), and Link Protocol Type (1:1). Below this is the 'Node Setup' section. A sub-dialog box titled 'CC-Link Intelligent Device Parameter Setting' is open, showing: No. of nodes to occupy (radio buttons for 1 and 4, with 1 selected), GP station number (1-64) (1), Baud rate (bps) (156k), Input data state on data link error (radio buttons for Clear and Hold, with Clear selected), and Use remote ready flag (radio buttons for Off and On, with Off selected). Buttons for OK, Cancel, and Help are visible in the sub-dialog.

9.3.5 Error Codes

■ PLC Error Codes

The error codes specific to the PLC will appear on the GP screen’s left bottom, as follows:

Host Communication Error (02::**:##)’.**

The “**” characters indicate an error code specific to the PLC (via the 16 system), and the “##” characters indicate the PLC number, on which an error occurred.

<e.g.> When “0xB802” is returned from node No. 1, the error code will appear as follows:

Host Communication Error (02:B8:02:01)



For more detailed information about error codes, refer to the following Mitsubishi Electric’s manuals:

AJ61BT11/A1SJ61BT11 Unit CC-Link System Master and Local Unit User’s Manual (Details)

AJ61QBT11/A1SJ61QBT11 Unit CC-Link System Master and Local Unit User’s Manual (Details)

QJ61BT11 Unit CC-Link System Master and Local Unit User’s Manual (Details)

◆ Error Codes Specific to GP CC-Link Intelligent Device

The error codes specific to the GP’s internal CC-Link intelligent device nodes are as follows. Each error code will appear on the GP screen’s left bottom, in a format of “Host Communication Error (02:**)’.

The “**” characters reflect one of the following error codes.

Error Code	Error
01	The check sum did not match during initialization.
02	The check sum reverse did not match during initialization.
03	Data link normal activation was not completed after initialization.
04	Shared memory read request was failed.
05	Shared memory write request was failed.
06	There was no response from the firmware during initialization.
11	An incorrect device code was designated during device read.
12	The transient command procedure was not normally completed during device read.
21	An incorrect device code was designated during device write.
22	The transient command procedure was not normally completed during device write.
23	Out of the internal memory buffer area
30	Undefined error (This type of error usually never occurs and can occur due to program bugs, memory destruction, etc.)

10 Device Net

10.1 Connectable PLCs

The following tables list the PLCs that can be connected and used with the GP.





Co.	Series Name	CPU	Link Unit	Comments	PLC name in PRO/PBIII
Rockwell (Allen-Bradley)	SLC500	SLC-5/04	1747-SDN	Device Net Unit (GP070-DN41) is required.	Device Net Slave I/O
	PLC-5	PLC-5/20	1771-SDN		
Omron	SYSMAC CS1	CS1H-CPU67 CS1H-CPU66 CS1H-CPU65 CS1H-CPU64 CS1H-CPU63 CS1G-CPU45 CS1G-CPU44 CS1G-CPU43 CS1G-CPU42	C200HW- DRM21-V1		
Hitachi	S10mini	LQP000 LQP010 LQP011	LQE070		
Yokogawa Electric	FA-3	F3SP20-0N F3SP21-0N F3SP25-2N F3SP28-3N F3SP30-0N F3SP35-5N F3SP38-6N F3SP53-4H F3SP58-6H F3SP36-3N	F3LD01-0N		

MEMO

10.2 Slave I/O

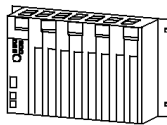
10.2.1 System Structure for Device Net Connection

The following table shows the system structure for connecting the GP to PLCs supporting Device Net.

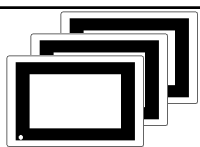
CPU	Link I/F	Cable Diagram	Recommended Cables	Link I/F	GP
					
PLC units compatible with Device Net	Device Net Master Unit	Cable Diagram 1	*1	Device Net I/F Unit (GP070-DN41)	GP70Series *2 (GP-370, GP-270, GP-H70, GP377R, and GP377 series are not supported)

*1 For the connectable cables,

Reference 10.2.2 ■ List of Cables for Device Net Connection.

*2 The DeviceNet-compatible GP units include: GP-470E, GP-570T, GP-570S, GP-570L, GP-57JS, GP-570VM, GP-571T, GP-675T, GP-675S, GP-477RE, GP-577RT, GP-577RS, GP-2500T, GP-2501T and GP-2600T. For GP2000 Series, a bus conversion unit is required.

■ Slave I/O

Slave I/O is the feature that converts I/O data automatically between the PLC installed with the master unit and GP unit.

Slave I/O uses a special link method that does not allow a user to access a PLC directly.

When using Device Net Connection the GP series unit performs like an I/O terminal (Remote terminal). The GP's LS area will be used as a device which inputs/outputs data with the host (PLC).

The master (host PLC) unit Output area is allocated to GP's Input area, and the master's Input area is allocated to GP's Output area. The LS area's Input area is followed in sequence by the Output area. (See below)

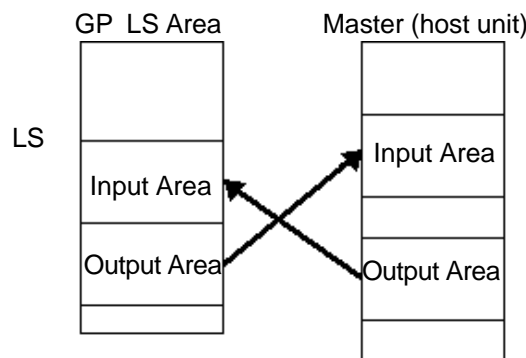



Note: Only the LS Area's User Area (from LS20 to LS1999) is used for this communication.

The System Area (from LS0 to LS19) and Reading Area settings cannot be used for PLC communication.

GP will be used as a slave unit.

Explicit Message Communication is not supported.

10.2.2 Cable Diagram

<Cable Diagram 1>

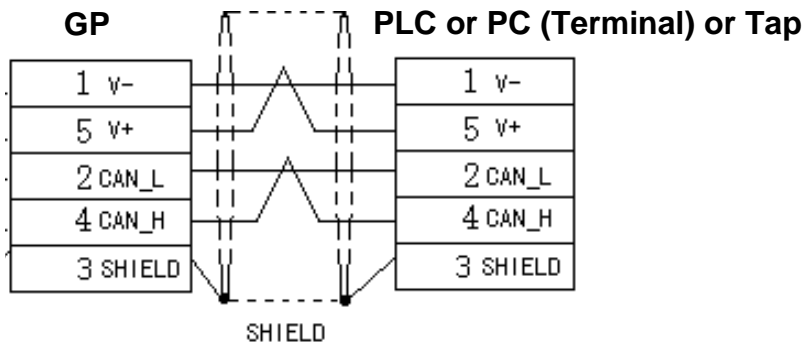

Pin No.	Wire Cover Color	Comment
1	Black	Power Supply (V-)
2	Blue	Communication Data [Low side] (CAN_L)
3	None	Shield
4	White	Communication Data [High side] (CAN_H)
5	Red	Power Supply (V+)

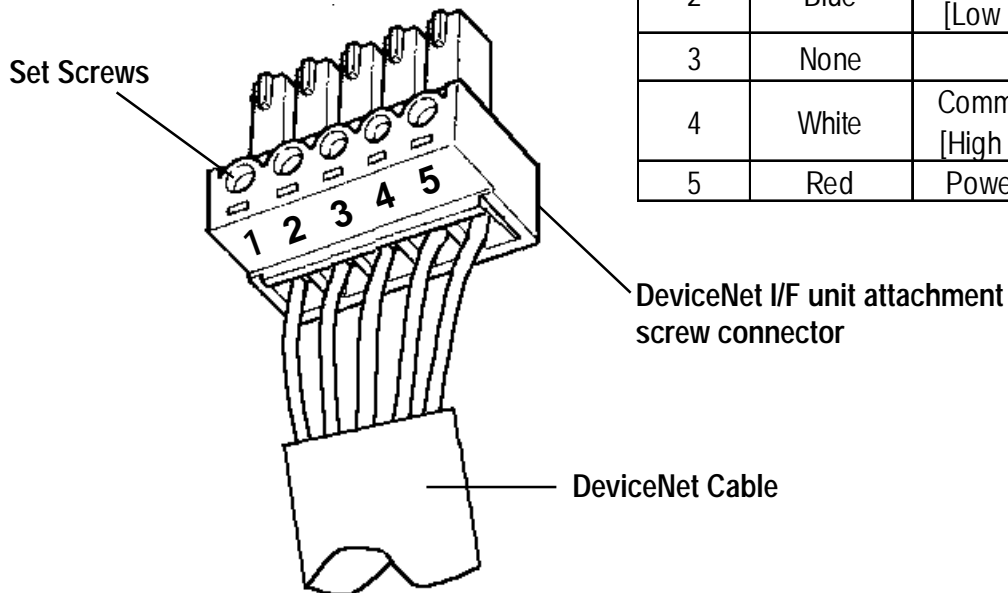

After all connector wires are attached to the connector, connect the connector to the Device Net I/F Unit (5-wire type).

Be sure to connect Terminating Resistors (121Ω/4W) to both sides of the cable.



■ **List Device Net Cables**

There are two types of cable, thick and thin, for the Device Net unit.

Be sure to use only cables that meet the Device Net specifications. The following two cables are recommended.

- Rockwell (Allen Bradley) Thick type 1485C-PI-A***
- Rockwell (Allen Bradley) Thin type 1485C-PI-C***

10.2.3 Environment Setup

The following lists Digital's recommended GP settings.

Baud Rate and Node Number Settings

◆ **GP Unit**

For setting the baud rate and the node number, use the Dip Switch (8 positions) on the rear side of the Device Net expansion unit (Model: GP070-DN41). The normal SIO communication setting cannot be used. Node number is available from 0 to 63 on the GP.

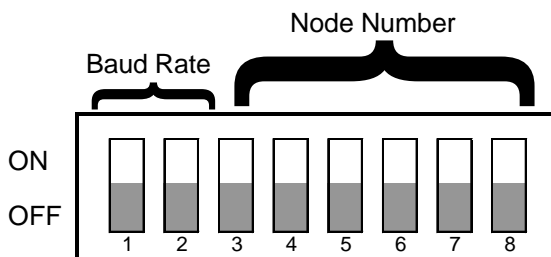

Baud Rate	DIPSW1	DIPSW2
125K	0	0
250K	0	1
500K	1	0
Reserved	1	1

Node No.	D3	D4	D5	D6	D7	D8
0	0	0	0	0	0	0
1	0	0	0	0	0	1
2	0	0	0	0	1	0
:	:	:	:	:	:	:
61	1	1	1	1	0	1
62	1	1	1	1	1	0
63	1	1	1	1	1	1

◆ **PLC Unit**

For PLC settings, refer to each company's Device Net communication unit's manual.

Input / Output area Settings

Enter the GP's communication settings via the SET UP OPERATION SURROUNDINGS menu.

< GP Example screen >

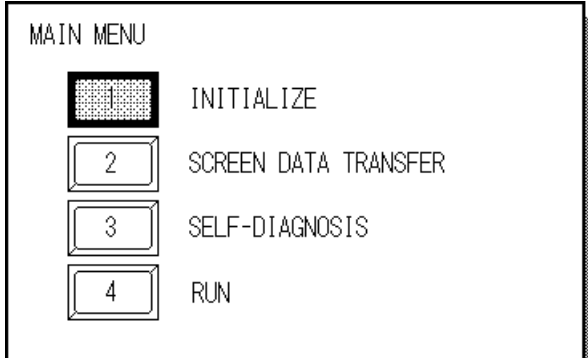

① Touch the INITIALIZE selection. The INITIALIZE menu will appear.

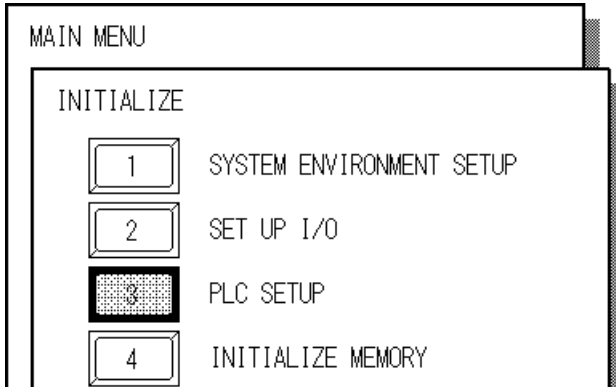

② Touch the PLC SETUP selection. The SET UP OPERATION SURROUNDINGS menu will appear.



Note: The Initialize screen's SET UP I/O area's settings disabled.

◆ Enter the following settings to begin I/O communication.

- In the DIO Start Address, enter a value from LS20-LS1999.
- In the Input Area Size, enter a value from 0-127 words.

Set the word area size that is equal to the output area size of the DeviceNet master unit.

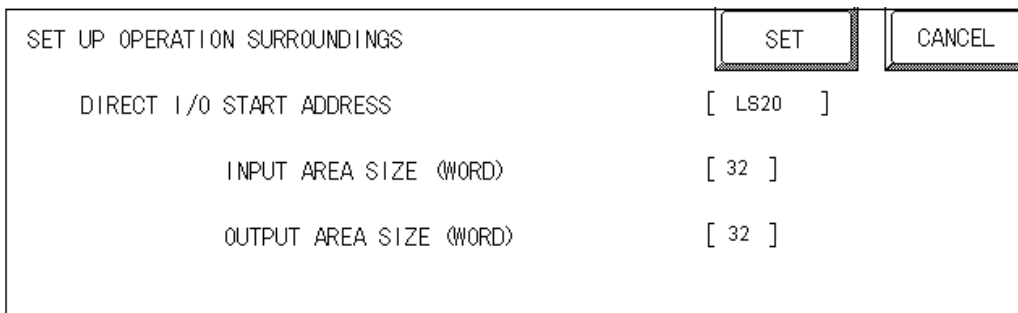

- In the Output Area Size, enter a value from 0-127 words.
Set a word area size equal to the input area size of the DeviceNet master unit.



The GP's SYSTEM DATA AREA(LS0 to LS19) cannot be allocated.

< PLC Settings >

For PLC settings, refer to each company's Device Net communication unit's manual.

10.2.4 Supported Devices

	Word Address	Particulars	
Input Area Size (word)	0 to 127	*1	L/H
Output Area Size (word)	0 to 127	*1	
DIO Start Address	LS20 to LS1999	*2	

**1 Though the Input /Output area size can be set from 0 to 127, the maximum I/O size used per slave will differ depending on each company's master unit specifications.
The I/O size that each company supports is shown as below.*

PLC Series	Input Area Size (word)	Output Area Size (word)
Rockwell SLC500	0 to 64	0 to 64
Rockwell PLC-5	0 to 64	0 to 64
Omron SYSMAC CS1	0 to 32	0 to 32
HITACHI S10mini	0 to 127	0 to 127
YOKOGAWA FA-M3	0 to 127	0 to 127

**2 Designate the DIO Start Address within the range shown below.
 $20 \leq \text{DIO Start Address} \leq 2000 - \text{Input Area Size} - \text{Output Area Size}$*

*e.g: When Input Area Size =4, and Output Area Size =16,
the setting range of the DIO Start Address should be:
 $20 \leq \text{DIO Start Address} \leq 1980$*

10.2.5 Error Codes

The following list shows the error codes for the Device Net connection. These error codes will appear as "PLC COM.ERROR (02:**)" on the bottom left on the GP screen. (** stands for an error code.)

Error Code	Details	Status
14	No reply from the hardware	Unit is not properly installed
		Unit Error
16	A communication error occurred	Communication Setting Error
		Communication Line Error
		Node No. is duplicated

11 Interbus

11.1 Connectable PLCs

The following tables list the PLCs that can be connected and used with the GP.

■ Direct I/O Mode

Maker	Series Name	CPU	Link Unit	Comments	PLC name in PRO/PBIII
Siemens	S7-400	CPU413-2DP	Phoenix Contact IBSS7-400 DSC/I-T		INTERBUS SLAVE
All others	Various PCs	—	Phoenix Contact IBS PC ISA SC/I-T		

■ Packet Transfer Mode



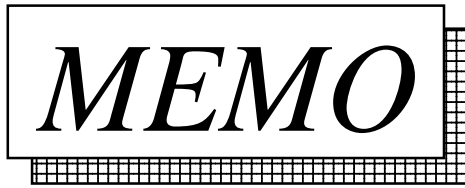

Maker	Series Name	CPU	Link Unit	Comments	PLC name in PRO/PBIII
Siemens	S7-400	CPU413-2DP	Phoenix Contact IBSS7-400 DSC/I-T		INTERBUS SLAVE

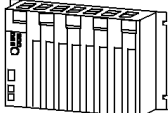
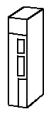

11.2 Slave I/O

11.2.1 System Structure

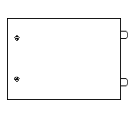
The following table shows the system structure for connecting the GP to Siemens PLCs and PCs.

CPU	Link I/F	Cable Diagram	Recommended Cables	Link I/F	GP
					
CPU413-2DP	Phoenix Contact IBS S7-400 DSC/I-T	(Cable Diagram 1)	Phoenix Contact IBS RBC 2M ^{*1} . KONFEX-T	Interbus Slave Module (GP070-IB41)	GP Series ^{*2}
Various PCs	Phoenix Contact IBS PC ISA SC/I-T	(Cable Diagram 1)			

**1 2M indicates the length of the cable as 2 meters. 5M indicates a length of 5 meters etc.*

**2 DeviceNet-compatible GP units include GP-470E, GP-570T, GP-570S, GP-57JS, GP-570VM, GP-571T, GP-675T, GP-675S, GP-477RE, GP-577RT, GP-577RS, GP-2500 and GP-2600. For GP2000 Series, a bus conversion unit (PSL-CONV00) is required.*



- The GP is used as a slave unit.

■ Direct I/O Mode

When communicating via Interbus in “Direct I/O” mode, the GP communicates with an Interbus master in a very simple manner. An area of memory is mapped from the GP’s LS area into the Interbus master’s input area and an area of the Interbus master’s output is mapped into the GP’s LS area. This is demonstrated in the following diagram example (Input & Output size 8 Words).

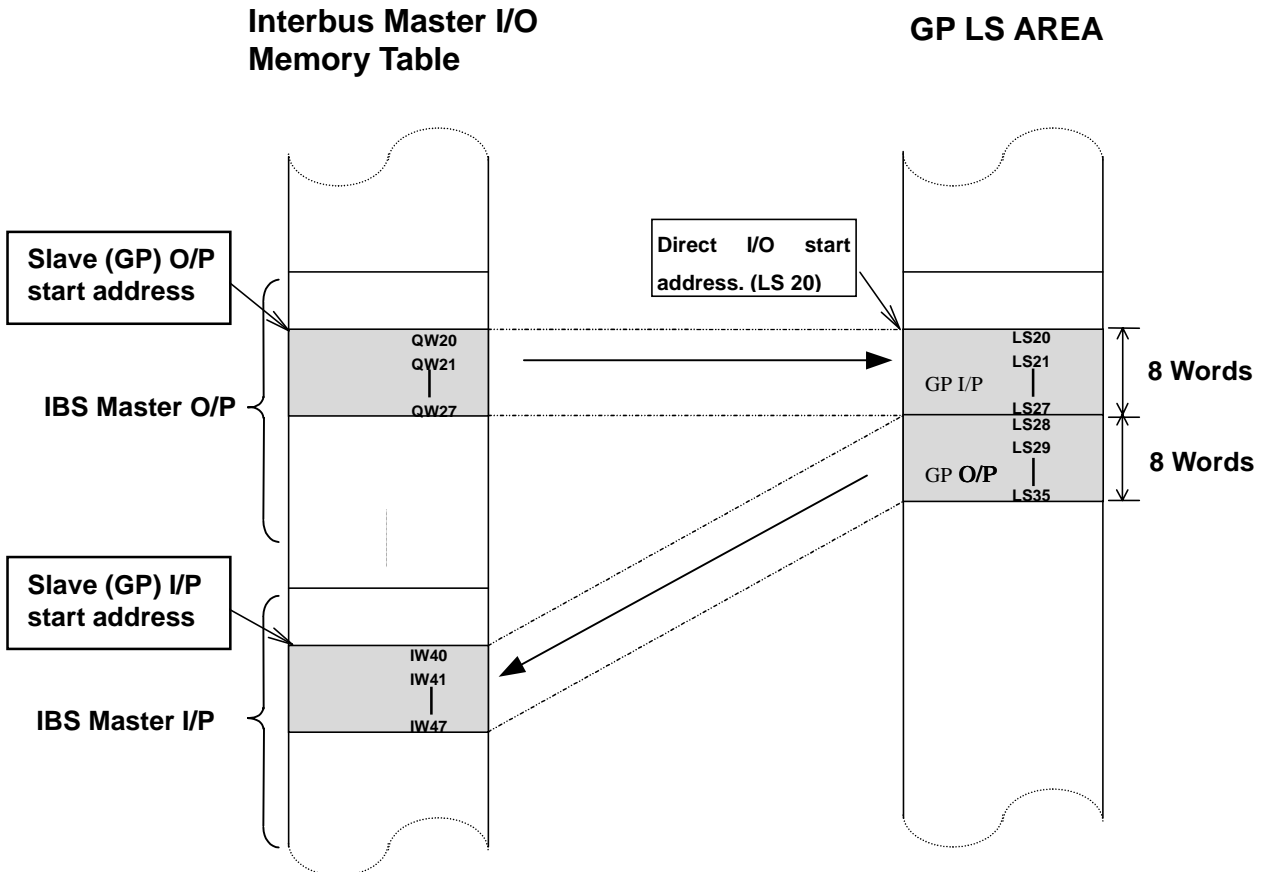

The GP Slave Input and Output start addresses and sizes (IW40 and QW20 in the above example) have to be configured using the Interbus Master's configuration software. Please refer to the Interbus Master's documentation for instructions on how to make these settings.

■ Packet Transfer Mode

When communicating via Interbus in “Packet Transfer” mode, the GP acts as a “Logical Master”, i.e. it can request to read and write any data areas in the PLC as if it was a master. In this mode an “Interpreter Function Block” is required in the PLC. In this mode the GP uses a fixed input and output area size (16 bytes or 8 words) of the PLCs I/O memory Table. The GP transmits commands (read or write requests) based on its outputs. The PLC’s interpreter function block scans this input area and performs the requested action, then places the result on the output area. See the diagram below for an explanation.

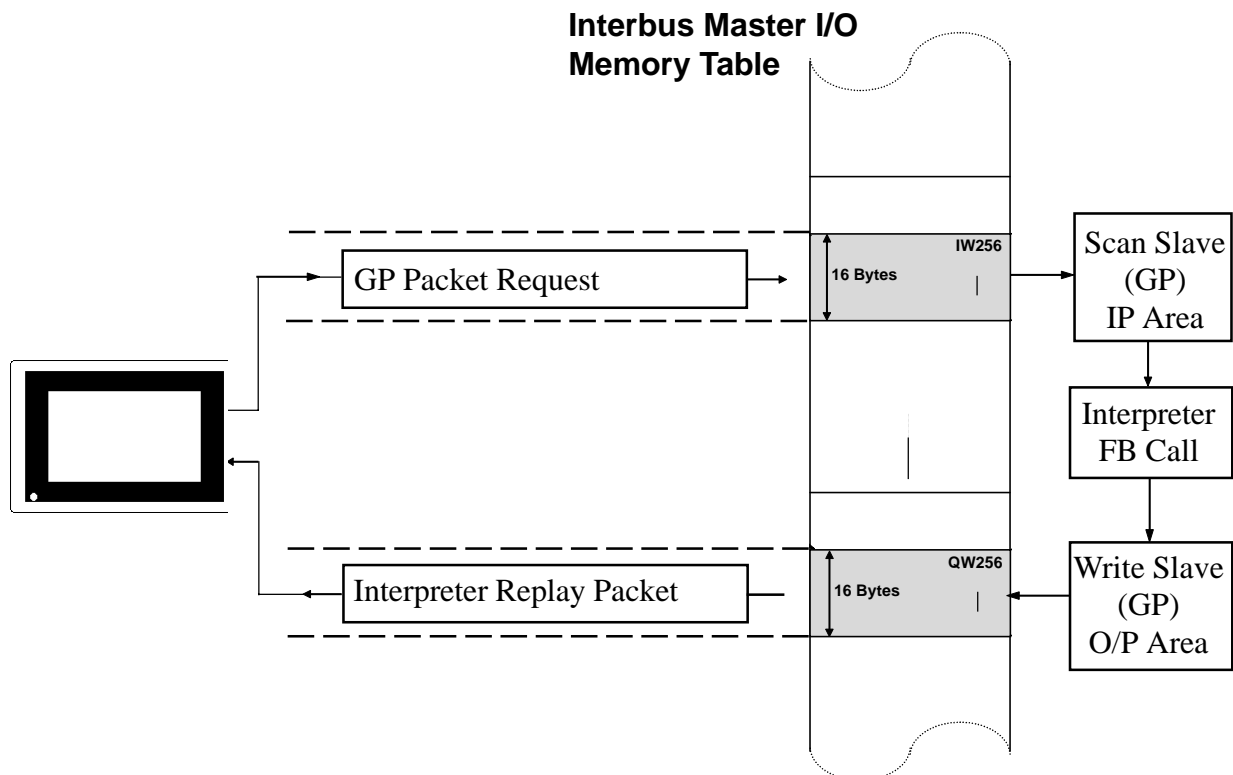

The GP Slave Input and Output start addresses and sizes (IW256 and QW 256 in the previous example) have to be configured using the Interbus Master's configuration software. Please refer to the Interbus Master's documentation for instructions on how to create these settings.

Currently a function block exists only for the S7-400 PLC. This should be called from OB1 of the Step 7 Program. Please refer to the following example for how to call this. Note: In this example the GP uses input address IW256 and output address QW256. It is also necessary to use 3 bytes of PLC internal memory. In this example, Marker bytes (MB) 100,101 & 102 are used.

```

OB1: MAIN BLOCK
  ???

Network 1 : GP-PROFIBUS/INTERBUS INTERPRETER CALL

IP/OP_ADDR: First I/O byte addresses of GP panel like configured in S7 HW CONFIG
             in decimal format
ERR_BYTE:   Interpreter error due to bad data format
             Byte 0: Bad device type (DB,M,I,O)
             Byte 1: Bad Data Block Address (word address over range)
             Byte 2: Attempt to write to a input
             Byte 3: Unknow Data block operations
             Byte 4: Interpreter general error
TEMP_OUT   Output byte 0 previous scan value
             Byte 6:
             Byte 7:

CALL FC 99
  IP_ADDR  :=256           // GP First input byte address
  OP_ADDR  :=256           // GP First input byte address
  ERR_BYTE :=MB100        // Interpreter error byte (see comment)
  TEMP_OUT :=MB101        // First output byte buffer for extended addressing
  GP_STATUS :=MB102       // Profibus new data request checking (see comment)

```



- **The Interpreter Function Block can be found in the example S7-400 PLC project is contained on the GP-PRO/PBIII for Windows CD-ROM which (folder name is "FIELDBUS"). This was created with version 3.2 of the Step 7 Software. Please follow the instration instructions in the README.TXT file on how to install this.**

11.2.2 Cable Diagrams

The cable diagrams shown below and the cable diagrams recommended by Phoenix Contact may differ. Using these cables for your PLC, however, will not cause any problems.

Cable Diagram 1

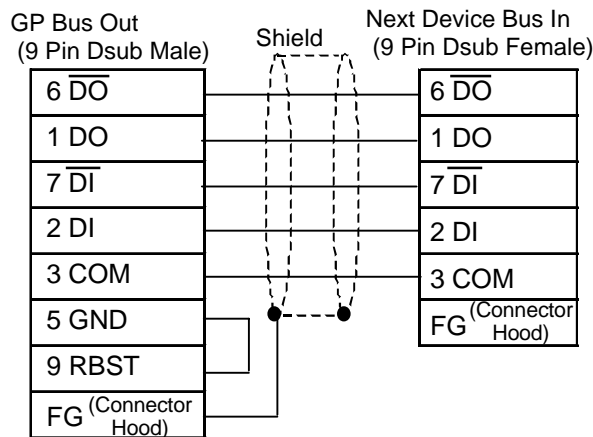
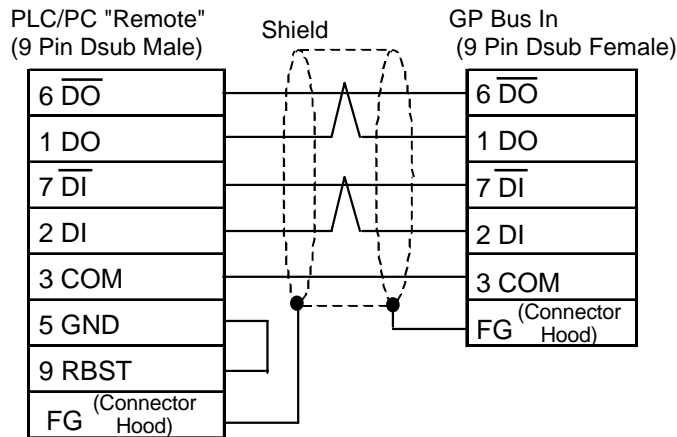

Reference For details, refer to Digital's GP70 Series Interbus I/F Unit Users Manual.

11.2.3 Supported Devices

■ Direct I/O Mode

	Word Address	Particulars	Default
Input Area size (Word)	0~10	Read Only	0
Output Area size (Word)	0~10		0
Direct I/O Start Address	LS0020-LS1999		LS20

The System Area (LS0 to LS19) and Reading Area settings cannot be used for PLC communications. Only LS Area's User's Area (LS20 to LS1999) can be used for communication. The maximum Input & Output Size is 10 Words (20 bytes) each.



- Only the LS Area's User Area (from LS20 to LS1999) is used for this communication.
- The System Area (from LS0 to LS19) and Reading Area settings cannot be used for the PLC communication.

■ Packet Transfer Mode

 Setup System Area here.

	Bit Address	Word Address	Note
Data Block	—	DB2W00000-DB60W65535	*1*2
Input Relay	I000000-I655357	IW00000-IW65534	*3*4
Output Repay	O000000-O655357	OW00000-OW65534	*3
Internal Memory	M000000-M655357	MW00000-MW65534	*3

- *1 The Data Block Memory to be used in the GP-PRO/PBIII for Windows must be configured in the PLC first. Please confirm that all addresses to be accessed already exist in the PLC.
- *2 The address format for Data Block Memory is according to Siemens S7 conventions. This is word (16 bit) addressing of Byte addresses so only even addresses are valid e.g. DB2W0050 represents Data Block 2, Word 50.
- *3 The address format for these devices is according to Siemens S7 conventions. For bit addressing the last digit represents the bit position, e.g. I0164 represents byte 16, bit number 4. For word addressing only even byte addresses can be used.
- *4 Input relays cannot be written to by the GP.



- The Interpreter Function Block can be found in an example S7-400 PLC project that is contained on the GP-PRO/PBIII for Windows CD-ROM in the folder "FIELDDBUS". This was created with version 3.2 of the Step 7 Software. Please follow the instructions in the README.TXT file on how to install this.

11.2.4 Environment Setup

There are no communication parameters to be set up on the GP side of the Interbus Connection. The Master PLC/PC automatically assigns node addresses to each slave on the network and the baud rate is fixed at 500 Kbps.

	GP	PLC/Interbus Master
Transmission speed	500 Kbps (fixed)	500 Kbps (fixed)
Node No.	Automatically Configured	Automatically Configured

The GP's OFFLINE screen used to enter these communication settings is shown below. The settings on this screen govern the manner in which the GP communicates via Interbus, i.e. the communication data type (Direct I/O or Packet Transfer) and for Direct I/O; the addresses in the GP's internal memory where data will be read and written from, and the sizes of these blocks of data. These settings can be also made from the GP setup menu in GP-PRO/PBIII for Windows software. For Packet Transfer please set the Input and Output Area Size via this menu.

◆ **From the initial OFFLINE menu screen:**

- 1) Select [INITIALIZE] to call up the initial settings screen.
- 2) Select the [SET UP OPERATION SURROUNDINGS] menu item (screen below appears).
- 3) Configure the environment settings to suit your particular requirements. (Ex. Direct I/O, Input/Output Area Size, etc.)

```

SET UP OPERATION SURROUNDINGS

SYSTEM DATA AREA  START DATA BLOCK [  0010  ]

                        START DATA WORD [  000  ]

SYSTEM AREA READING AREA SIZE (0 - 256) [  0  ]

COMMUNICATION DATA TYPE                DIRECT I/O  PACKET

DIRECT I/O START ADDRESS                  [ LS0020  ]

                        INPUT AREA SIZE    [  8  ]

                        OUTPUT AREA SIZE   [  8  ]

```

The input and output area sizes used here must match those set up in the Interbus Master's configuration for the GP slave. Please refer to the Interbus Master's documentation. For Packet Transfer Mode, the input and output size are fixed at 16 bytes.

11.2.5 Interbus Specific Error Code

The following list shows the error codes for the Device Net connection. These error codes will appear as "PLC COM.ERROR (02:**)" on the bottom left on the GP screen. (** stands for an error code.)

Error Code	Details	Status
14	No reply from Interbus H/W module	Unit is not properly installed, or unit failure
16	Interbus Not online	Configuration error

12 Indicating Controllers

12.1 Connectable Controllers

Company	Series	Controller ¹	Note	PLC name in Pro/PB III	
Yokogawa Corp.	UT2000 Series	UT2400-□ UT2800-□		YOKOGAWA FACTORY ACE 1:1 Comm. or YOKOGAWA FACTORY ACE 1:n Comm.	
Yokogawa M&C Corp.	GREEN SERIES	UT320-□1 UT350-□1 UT420-□7 UT450-□1 UT450-□2			
Yamatake Corp.	SDC	SDC20, SDC21 SDC30, SDC31 SDC40A, SDC40B SDC40G		YAMATAKE SDC SERIES	
	DMC	DMC10			
RKC INSTRUMENT INC.	CB Series	CB100 Z-1021 CB400 Z-1021 CB500 Z-1021 CB700 Z-1021 CB900 Z-1021		RKC CB/SR-Mini Series	
	SR-Mini	H-PCP-A Z-1021			
Omron Corporation	N-Series Controller	E5EN-□□□□□-FLK *2 E5CN-□□□□□-FLK E5GN-□□□□□-FLK E5AN-□□□□□-FLK		OMRON THERMAC NEO	
Sinko Technos Corp.	C	CPT-20A	Optional unit is required when using multiple channels. ^{*3}	SHINKO TECHNOS INDICATING	
	FC	FCD-13A□□,C FCD-13A□□,C5 FCD-15A□□,C FCD-15A□□,C5 FCR-13A□□,C FCR-13A□□,C5 FCR-15A□□,C FCR-15A□□,C5	When using the Controller for the first time, select the serial communication option. (.C:RS-232C) (.C5:RS-485) ^{*4}		
		FIR			FIR-201-M□□,C FIR-201-M□□,C5
		GC			GCS-300□□,C5
		FCL			FCL-13A□□,C5
	PC-900	PC-935□□,C PC-935□□,C5 PC-955□□,C PC-955□□,C5			

Company	Series	Controller *1	Note	PLC name in PRO/PBIII
Fuji Electric Corporation	Micro-Controller X	PXR4□□□□-□□M00 *5 PXR4□□□□-□□V00		FUJI TEMPERATURE PXR
TOHO ELECTRONICS INC. *6	TTM-004	TTM-004-□-A□□□		TOHO ELECTRONICS TTM SERIES
	TTM-X04	TTM-X04-□-□□□□		
	TTM-00B	TTM-00B-□-□□□□		
	TTM-10L	TTM-10L-□-□-□ *7		
	TTM-100B	TTM-100B4-□□-□□□□-□□□		
		TTM-100B8-□□-□□□□-□□□		
	TTM-110 Series	TTM-114-□-□ □-□□□□□□□-□		
		TTM-115-□-□ □-□□□□□□□-□		
		TTM-117-□-□ □-□□□□□□□-□		
	TTM-110B	TTM-119-□-□ □-□□□□□□□-□		
		TTM-110B-□-□ □-□□□□□□□-□		
	TTM-120 Series	TTM-124-□-□ □-□□□□□□□-□		
		TTM-125-□-□ □-□□□□□□□-□		
		TTM-127-□-□ □-□□□□□□□-□		
TTM-129-□-□ □-□□□□□□□-□				
TTM-300 Series	TTM-304-□-□N-□□□□-□			
	TTM-305-□-□N-□□□□-□			
	TTM-309-□-□N-□□□□-□			
TTM-300B	TTM-300B-□-□N-□□□□-□			
TTM-1020 Serie	TTM-1520-□ □-□ □-□□□□-□			
	TTM-1521-□ □-□ □-□□□□-□			
	TTM-1522-□ □-□ □-□□□□-□			
	TTM-1523-□ □-□ □-□□□□-□			
	TTM-1524-□ □-□ □-□□□□-□			
	TTM-1525-□ □-□ □-□□□□-□			
	TTM-1920-□ □-□ □-□□□□-□			
	TTM-1921-□ □-□ □-□□□□-□			
	TTM-1922-□ □-□ □-□□□□-□			
	TTM-1923-□ □-□ □-□□□□-□			
	TTM-1924-□ □-□ □-□□□□-□			
TTM-1925-□ □-□ □-□□□□-□				

*1 The Controller's model number "□" will vary depending on each controller's functionality specifications.

*2 Omron Controller's model number consists of the following items.

Standard No. - □□□□□-□

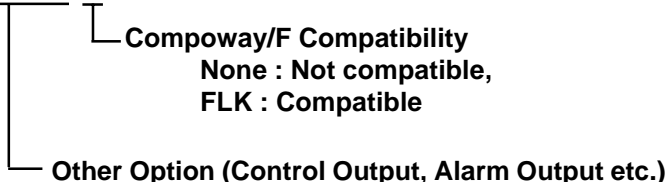

*3 When using multiple channels with a C Series unit, the 2 ch temperature control unit (CCT-235-2-□□) is required. For model number details “□□”, refer to the C Series catalog.

*4 Items with the serial communication option have a “,C” or “,C5” after the basic model number.

Ex.) When specifying the RS-232C serial communication option for the FC Series.

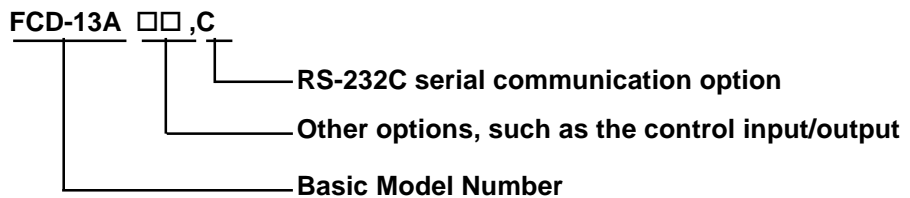

*5 When connecting the Controller to a GP, the RS485(MODBUS) option “M00” or “V00” is required.

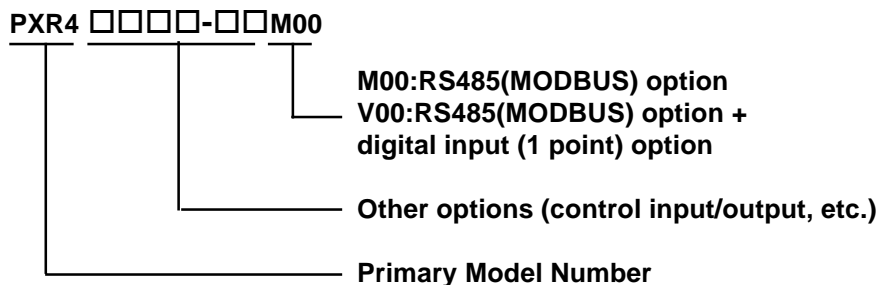

*6 About TOHO Controller's Model Number

The Controller model number is used to designate if a Controller is equipped with communication features or not. To check whether your Controller has communication features, refer to your Controller's User Manual or Catalog.

For example, the Controller model number of the TTM-004 Controller is shown below. Only Controllers with the character "M" in their model number's Option section (the three right-most characters) are equipped with communication feature.

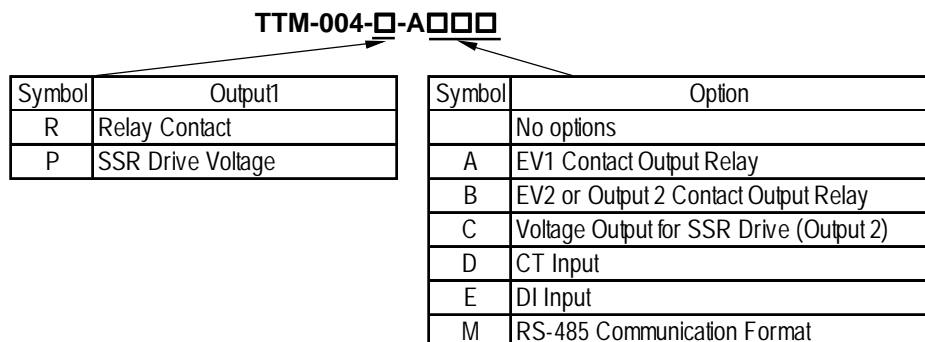

**7 TTM-10L Unit Communication Format*

Depending on the unit's model number, the TTM-10L can use, either the RS-485 or the RS-232C format. Select the Communication Format as shown below (Communication Format can be selected either RS-485 or RS-232C.).

TTM-10L-□-□-□



Symbol	Option
	No options
A	Event Output
M1	RS-485 Communication Format
M2	RS-232C Communication Format



12.2 Yokogawa Electric/Yokogawa M&C Controllers

12.2.1 System Structure

This chapter describes the system configuration used when connecting this Controller to the GP/GLC.

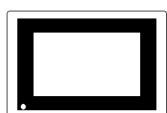

■ Yokogawa UT2000 Series/Yokogawa M&C GREEN SERIES

(1:1 communication)

Controller ^{*1}	Cable Diagram	GP/GLC
		
UT2400-□ UT2800-□ UT320-□1 UT350-□1 UT420-□7 UT450-□1 UT450-□2	RS-422 (4 wires) <Cable Diagram 1>	GP/GLC Series

**1 The Controller's model number "□" will vary depending on each controller's functionality specifications.*

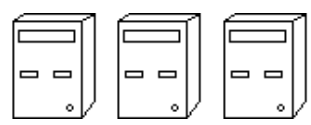
(1:n (multi-drop) Communication)

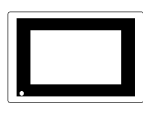
Controller ^{*1}	Cable Diagram	GP/GLC
		
UT2400-□ UT2800-□ UT320-□1 UT350-□1 UT420-□7 UT450-□1 UT450-□2	RS-422 (4 wires) <Cable Diagram 2>	GP/GLC Series

**1 The Controller's model number "□" will vary depending on each controller's functionality specifications.*

12.2.2 Cable Diagrams

The cable diagrams shown below and those recommended by Yokogawa or Yokogawa M&C may differ, however, using these cable connections for your Controller's operations will not cause any problems.



- Ground the Controller's FG terminal according to your country's applicable standard.



- When connecting the FG wire to the cable connector's hood, be sure that the hood material is conductive.
- The maximum RS-422 cable length is 500 meters. When connecting this cable, be sure to connect the SG terminal.

Terminal Numbers Used When Using an RS-422 Cable



- The terminal numbers used when using an RS-422 cable for connection will vary depending on each Controller model.

On the cable diagram, however, these terminal numbers are not shown, and please refer to the numbers shown below for cable connection.

◆ Yokogawa UT2000 Series

Signal Name	Terminal No.
TX+	4
TX-	6
RX+	3
RX-	5
SG	2
FG	1

◆ Yokogawa M&C GREEN Series

Signal Name	Terminal No.
SDA(-)	24
SDB(+)	23
RDA(-)	26
RDB(+)	25
SG	27

Cable Diagram 1 (1:1) (RS-422 4 Wires)

<When using Digital's RS-422 connector terminal adapter GP070-CN10-0>

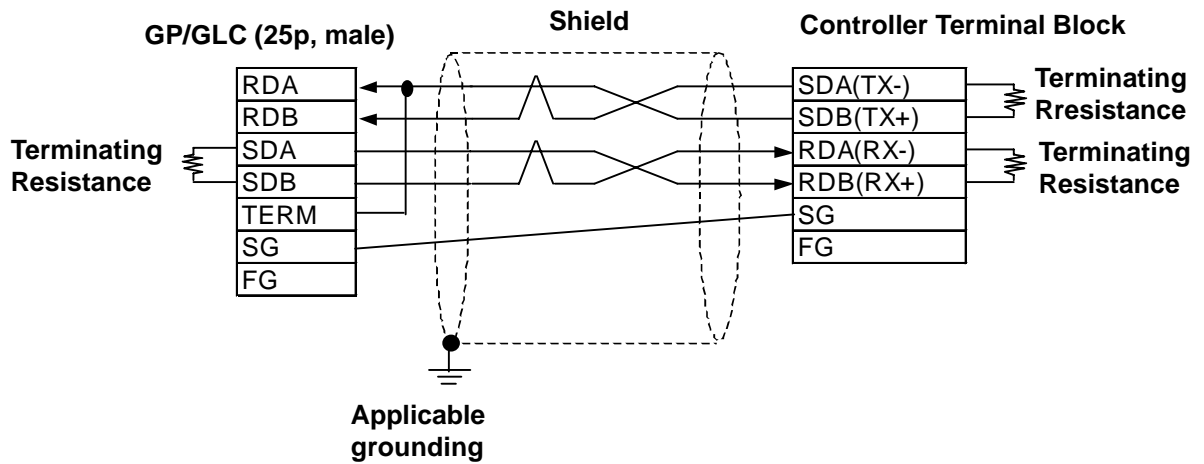

<When preparing a cable on your own specifications>

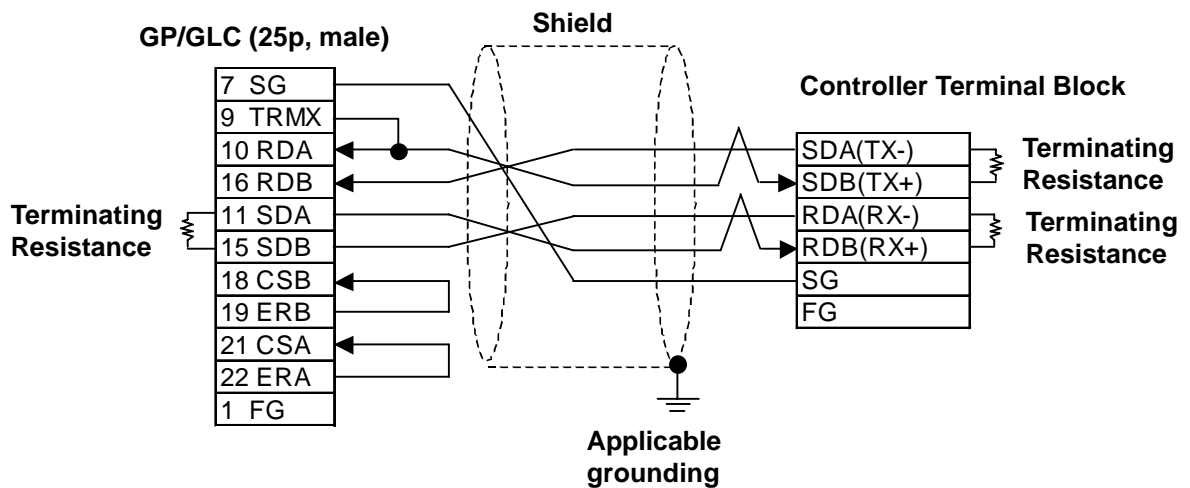

Note: Hitachi Densen's CO-SPEV-SB(A)3P*0.5SQ cable is recommended.

Depending on the Controller model, the FG terminal may not be equipped.

The GREEN SERIES' terminating resistance is 220Ω (1/4W) and the UT2000 Series' terminating resistance is 100Ω(1/2W) or more.

Connecting the GP/GLC serial interface's Nos. 9 and 10 pins will insert 100Ω terminating resistance between RDA and RDB.

When using an RS-422 cable, be sure to keep its length within 500 meters.

Cable Diagram 2 (1:n) (RS-422 4 Wires)

<When using Digital's RS-422 connector terminal adapter GP070-CN10-0>

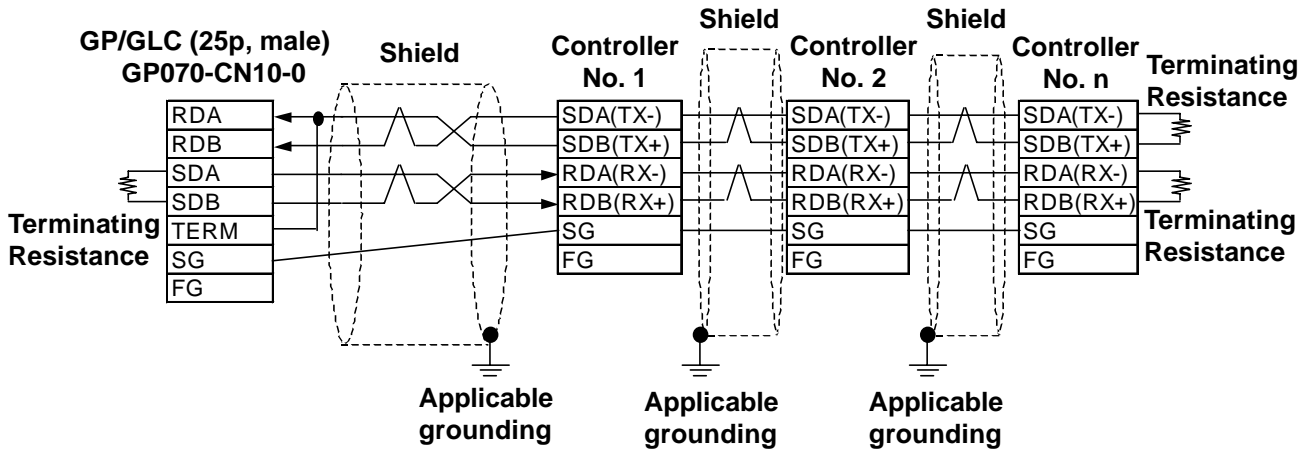

<When preparing a cable on your own specifications>

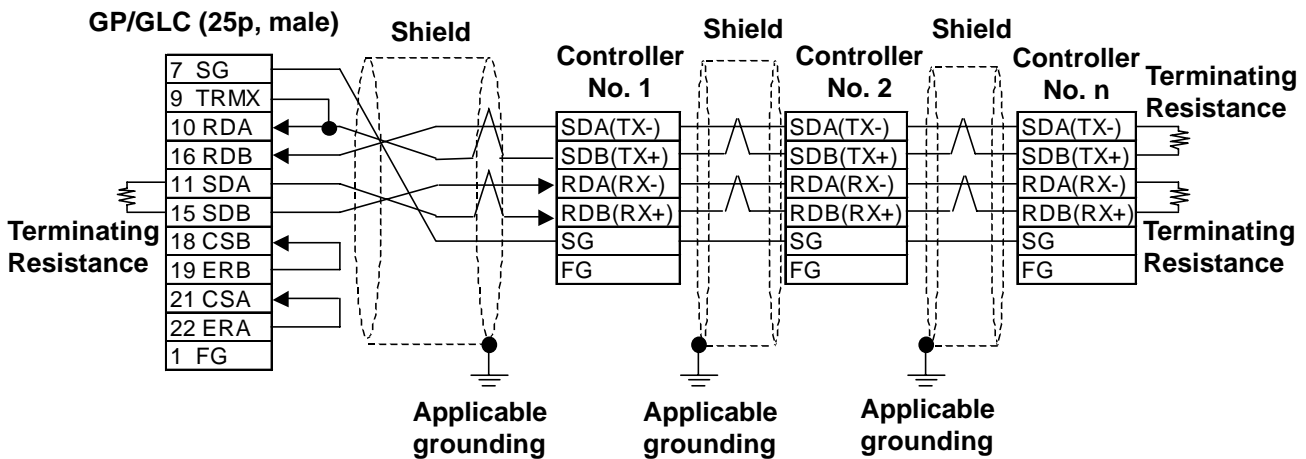

Note:

The maximum RS-422 (4 wires) cable length is 500 meters.

Up to 31 Controllers (up to 16 for UT2000 Series) can be connected.

Depending on the Controller model, the FG terminal may not be equipped.

The GREEN SERIES' terminating resistance is 220Ω(1/4W) and the UT2000 Series' terminating resistance is 100Ω(1/2W) or more.

12.2.3 Supported Devices

The following lists show the ranges of devices supported by the GP/GLC.

■ Yokogawa UT2000 Series

Depending on the Controller model, prohibit areas are specified even within the following ranges.

Reference Refer to Yokogawa's "UT2000 Detailed operation manual"

Device	Bit Address	Word Address	Remarks
I	I0001 ~ I1024	I0001 ~ I1009	$\div 16 + 1$
D	—————	D0001 ~ D1024	Bit 5

L/H

■ Yokogawa M&C GREEN SERIES

Depending on the Controller model, prohibit areas are specified even within the following ranges.

Reference Refer to Yokogawa M&C's "UT350/UT320 Digital Indicated Controllers Operation Manual" and "GREEN SERIES further User's Manual".

Device	Bit Address	Word Address	Remarks
I	I0001 ~ I2048	I0001 ~ I2033	$\div 16 + 1$
D	—————	D0001 ~ D1274	Bit 5

H/L



- **The system area (20 words) cannot be allocated to the Controller's own data area. Even though you can enter the system area settings via the GP screen editor software, or via the OFFLINE screen, it is impossible to actually allocate the system area to the Controller's data area.**
- **Be careful as the Device fields differ depending on the type of Controller. Refer to the Controller's manual for the range allowed for the device address area.**
After screen data is converted from a different type of Controller, be sure to check if the device addresses used are correct. Be sure to check the supported device addresses before using Trend graphs or tags in your screens that use multiple words over continuous addresses.



Note: When using tags in the screen editor software, the PLC Station number can be designated during address input. When a station number is not designated, the previously entered station number is automatically used. (The default value is 1.)

The screenshot shows the software interface for entering PLC addresses. It includes a 'Label' field, an 'Operation Bit Address' field containing '01/1000201', a 'Monitor' checkbox, a 'Monitor Bit Address' field containing '01/1:000101', and a 'Function' section with options like 'Bit Set', 'Bit Reset', and 'Momentary'. A 'Bit Address' dialog box is open, showing a dropdown menu with '1D' selected and a text input field containing '00201'. A numeric keypad is visible in the dialog box. Annotations include a line pointing from the text 'Address Controller's Station No.' to the '01' in the 'Operation Bit Address' field, and another line pointing from the text 'Enter the selected Controller's Station No.' to the '00201' in the 'Bit Address' dialog box.

12.2.4 Environment Setup

The following list shows the recommended Controller and GP/GLC communication settings.

■ Yokogawa UT2000 Series/Yokogawa M&C GREEN SERIES

GP/GLC Settings			Controller Settings		
Baud Rate	9600 bps		Baud Rate	9600 bps	
Data Length	8 bit		Data Length	8 bit	
Stop Bit	1 bit		Stop Bit	1 bit	
Parity Bit	Even		Parity Bit	Even	
Data Flow Control	ER		---	---	
Communication Format (When using RS-422)	4-wire Type		---	---	
---	---	---	For Dip Switch Communication Mode Selection	UT2000 Series	ON
			Protocol Selection (PSL)	GREEN SERIES	Personal computer link communication
Unit No.	UT2000 Series	1 ~ 16	Station No. (communication address)	UT2000 Series	1 ~ 16
	GREEN SERIES	1 ~ 31		GREEN SERIES	1 ~ 31

◆ Controller Communication Settings

<UT2000 Series>

Use the unit's rear face rotary switches:

- (1) Use the communication condition setting rotary switch to enter the communication condition.
- (2) Use the station number selection rotary switch to enter the unit number.
- (3) Turn the communication mode selection dip switch ON.

<GREEN SERIES>

Use the unit's front keys:

- (1) Hold down the Controller's [SET/ENT] key for 3 seconds or more to change the screen from [operation] to [operation parameter] .
- (2) When "OP.PA" appears on the measurement value (PV) display, use either Δ or ∇ key to display "STUP".
- (3) For UT350/UT320, every time you press the [SET/ENT] key, the screen will change one by one, in the order of [Protocol Selection] --> [Baud Rate] --> [Parity] --> [Stop Bit] --> [Data Length] --> [Communication Address].

For UT450/UT420, press the [SET/ENT] key once, and the [Setup Parameter Settings] screen will appear. Use either Δ or ∇ key to select "r485", and then, press the [SET/ENT] key again. After this, use the same procedure used for UT350/UT320.



12.3 Yamatake Controllers

12.3.1 System Structure



This chapter describes the system configuration used when connecting this Controller to the GP.





- **GP/GLC's System Area (LS0 to LS19) Settings**

The GP/GLC's system area (20 words) cannot be allocated to the Controller's own data area. Even though you can enter the system area settings via the GP's screen editor software or via the GP/GLC's OFFLINE screen, it is impossible to actually allocate the system area to the Controller's data area.



■ **Yamatake SDC Series (1:1 communication)**

Controller	Cable Diagram	GP/GLC
		
SDC 20 SDC 21 SDC 40A SDC 40B SDC 40G	RS-232C <Cable Diagram 1>	GP Series or GLC Series
SDC 20 SDC 21 SDC 30 SDC 31	RS-422 (4 wires) <Cable Diagram 2>	
SDC 40A SDC 40B SDC 40G	RS-422 (2 wires) <Cable Diagram 3>	

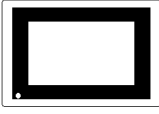

■ Yamatake SDC Series (1:n (multi-drop) communication)

CPU	Cable Diagram	GP/GLC
		
SDC 20 SDC 21 SDC 30 SDC 31 SDC 40A SDC 40B SDC 40G	RS-422 (4 wires) <Cable Diagram 4>	GP/GLC Series
	RS-422 (2 wires) <Cable Diagram 5>	

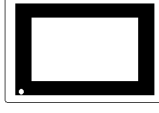
■ Yamatake DMC10 (1:1 communication)

CPU	Cable Diagram	GP/GLC
		
DMC10	RS-422 (2 wires) <Cable Diagram 6>	GP/GLC Series

■ Yamatake DMC10 (1:n (multi-drop) communication)

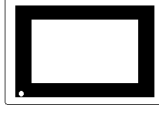
CPU	Cable Diagram	GP/GLC
		
DMC10	RS-422 (2 wires) <Cable Diagram 7>	GP/GLC Series

12.3.2 Cable Diagrams

The cable diagrams shown below and those recommended by Yamatake may differ, however, using these cables for Controller's operations will not cause any problems.



- **When connecting the FG terminal to the connector cover, be sure that the connector cover material is conductive.**
- **Ground the Controller's FG terminal according to your country's applicable standard. For details, refer to your Controller's manual.**
- **When connecting a cable's shield line to an FG terminal, consider the needs of your system when deciding which side of the cable (GP/GLC or Controller) to connect. (The example below connects to the Controller's FG terminal.)**
- **The maximum RS-232C cable length is 15 meters. If a communication cable is used, be sure to connect its SG (signal ground) terminal.**
- **The maximum RS-422 cable length is 500 meters.**
- **The recommended RS-422 cables are as follows:**

Recommended Cables

Company		Type
Fujikura Densen	2 wires	IPEV-S-0.9mm ² ×1P
	3 wires	ITEV-S-0.9mm ² ×1T
Hitachi Densen	2 wires	KPEV-S-0.9mm ² ×1P
	3 wires	KTEV-S-0.9mm ² ×1T

- **Since the Controller's terminal numbers will differ depending on the type of additional functions, check these numbers with the Controller's appropriate manual.**

Cable Diagram 1 (1:1) (RS-232C)

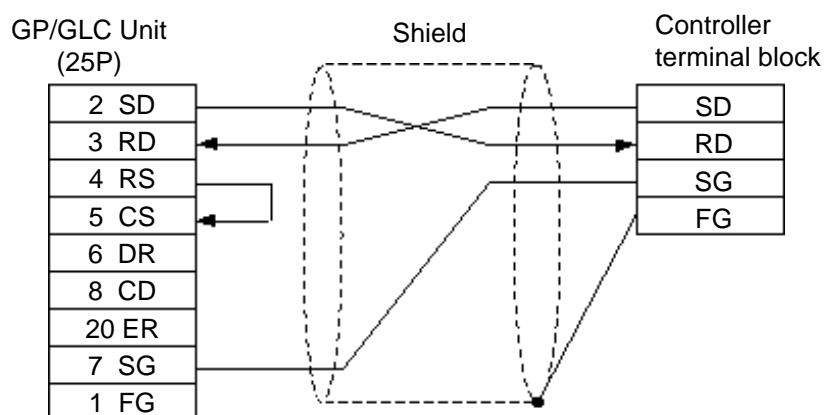

Cable Diagram 2 (1:1) RS-422 4 Wires, RS-422 5 Wires

<When using Digital's RS-422 connector terminal adapter GP070-CN10-0>

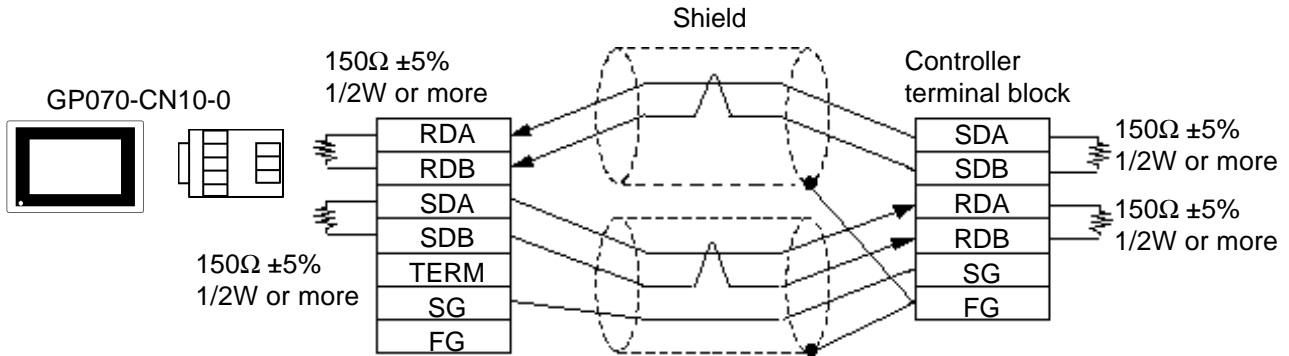

<When using Digital's RS-422 cable GP0230-IS11-0>

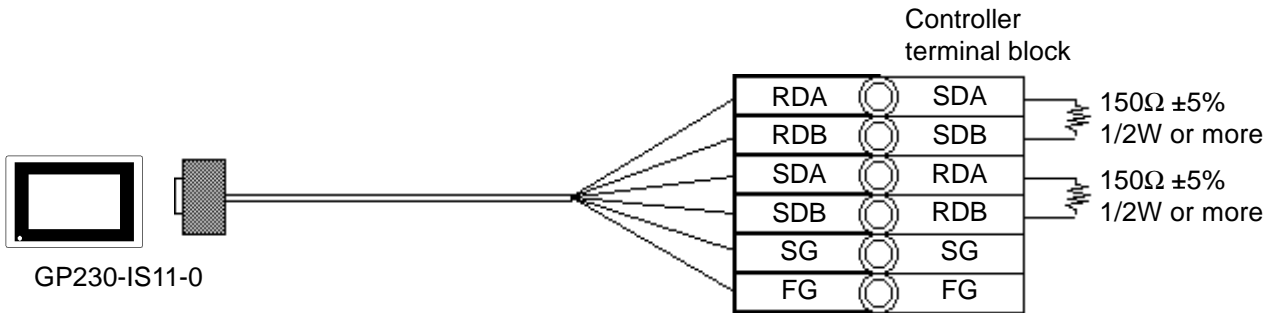

<When preparing your own cable>

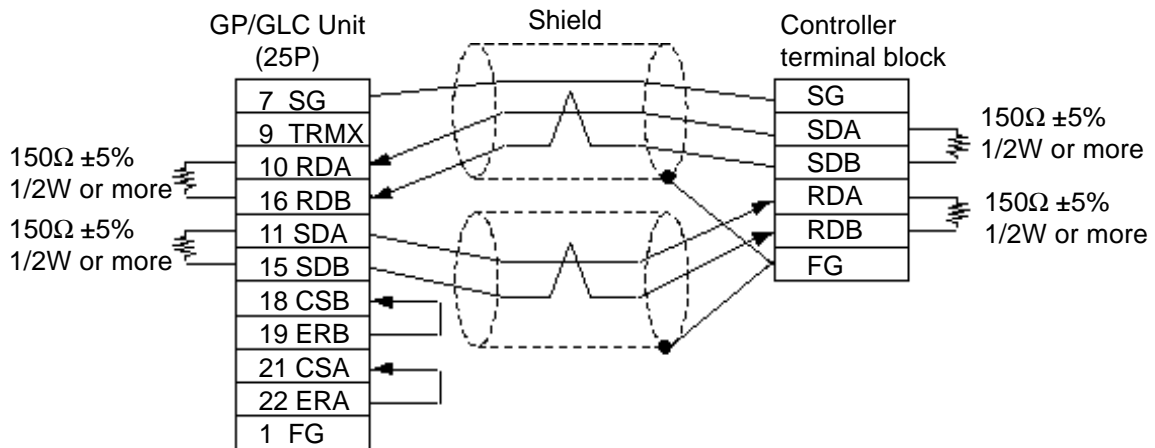

Cable Diagram 3 (1:1) RS-422 2 Wires, RS-422 3 Wires

<When using Digital's RS-422 connector terminal adapter GP070-CN10-0>

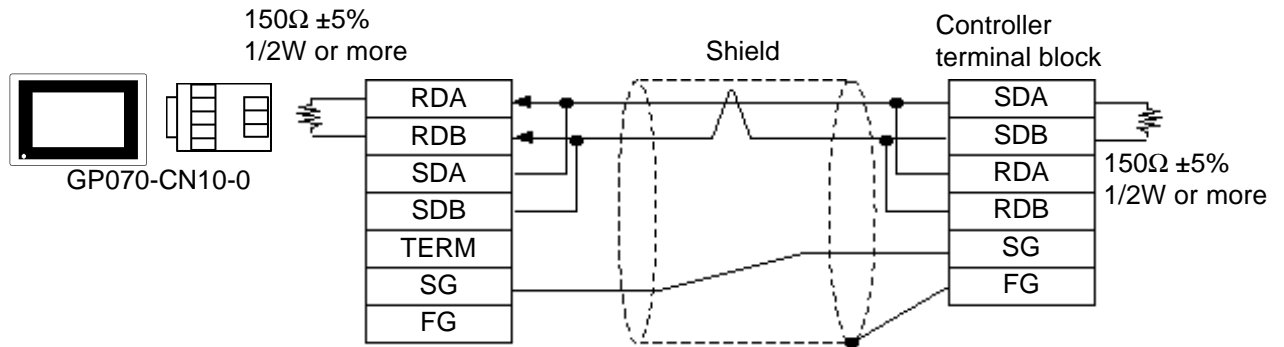

<When using Digital's RS-422 cable GP230-IS11-0>

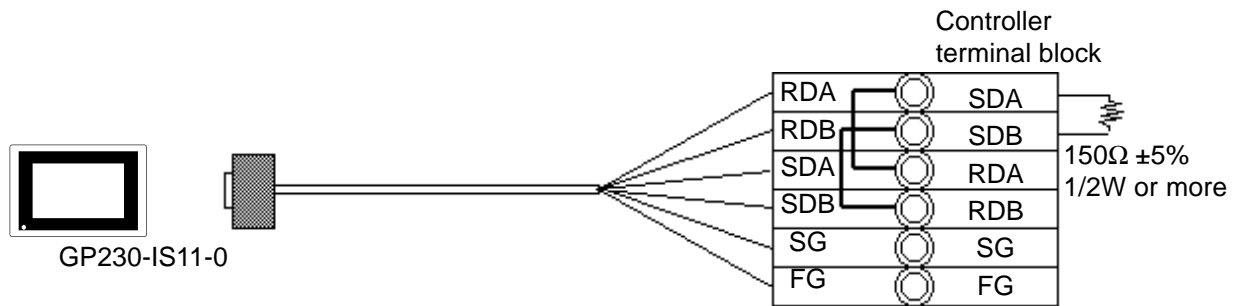

<When preparing your own cable>

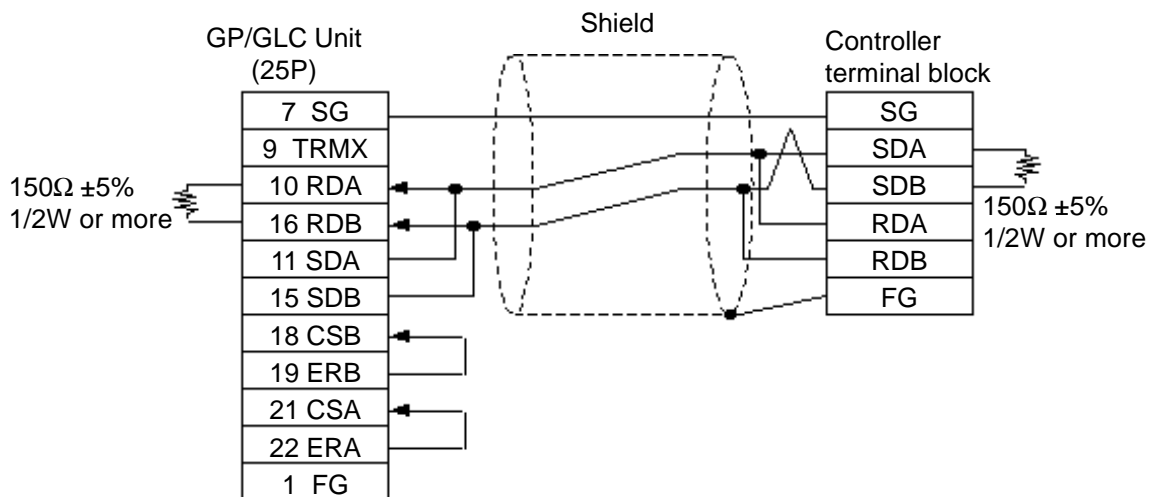

Cable Diagram 4 (1:n) RS-422 4 Wires, RS-422 5 Wires

<When using Digital's RS-422 connector terminal adapter GP070-CN10-0>

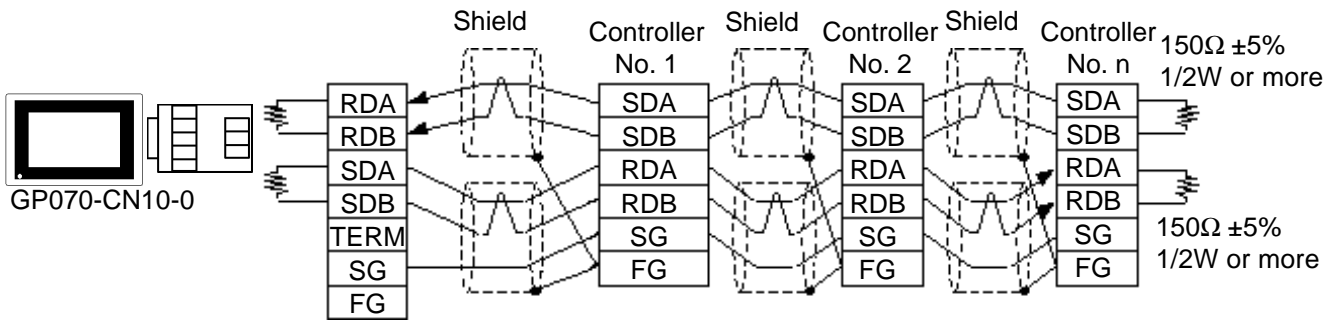

<When using Digital's RS-422 cable GP230-IS11-0>

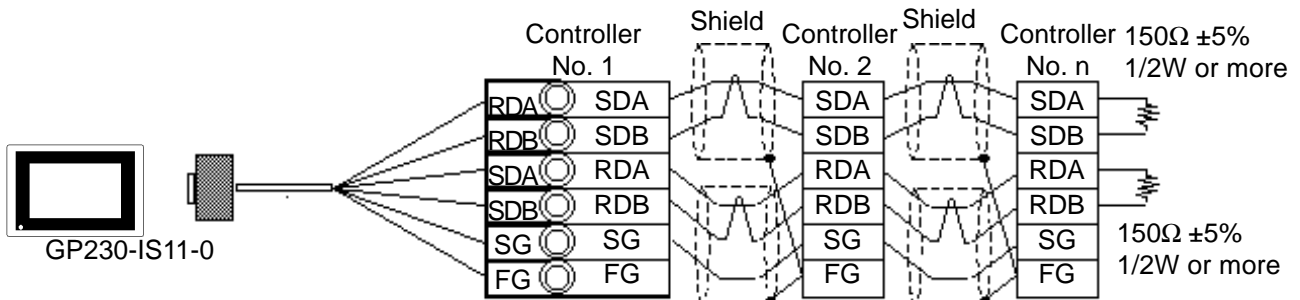

<When preparing your own cable>

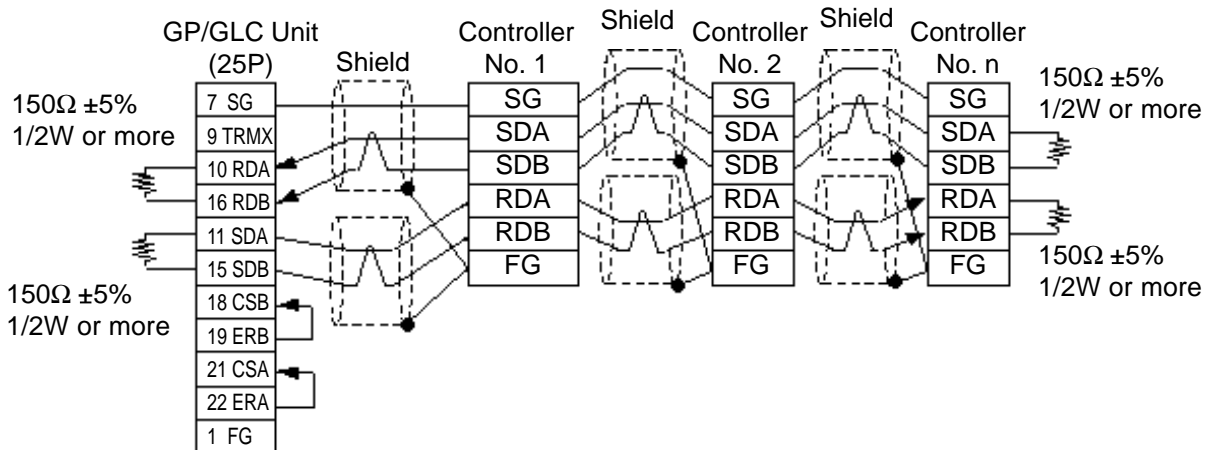

Cable Diagram 5 (1:n) RS-422 2 Wires, RS-422 3 Wires

<When using Digital's RS-422 connector terminal adapter GP070-CN10-0>

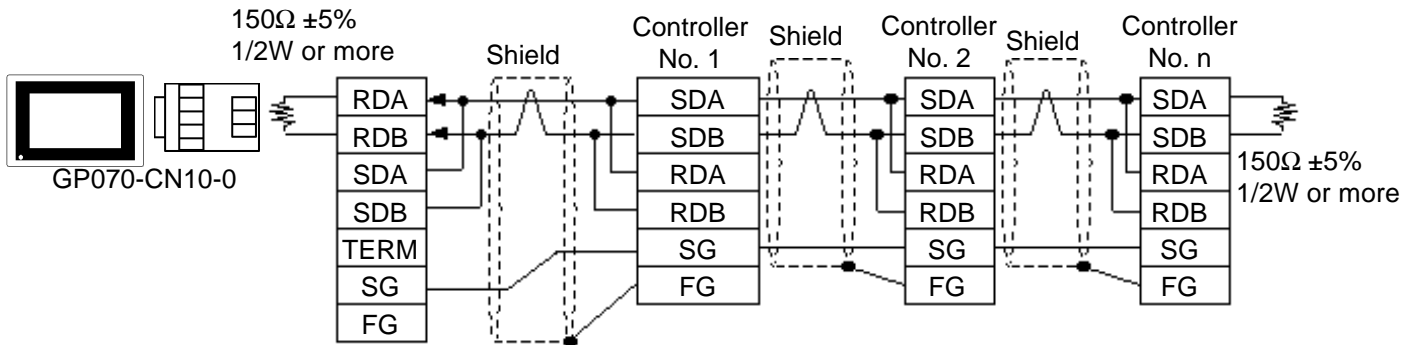

<When using Digital's RS-422 cable GP230-IS11-0>

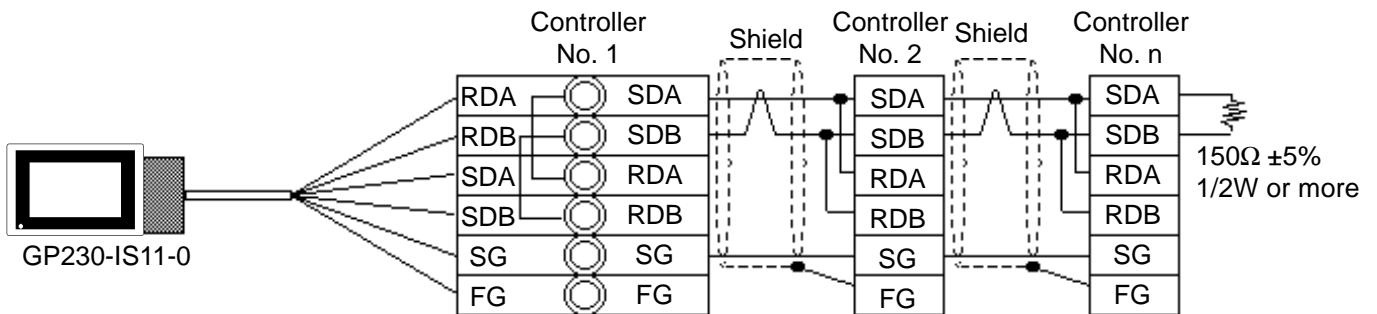

<When preparing your own cable>

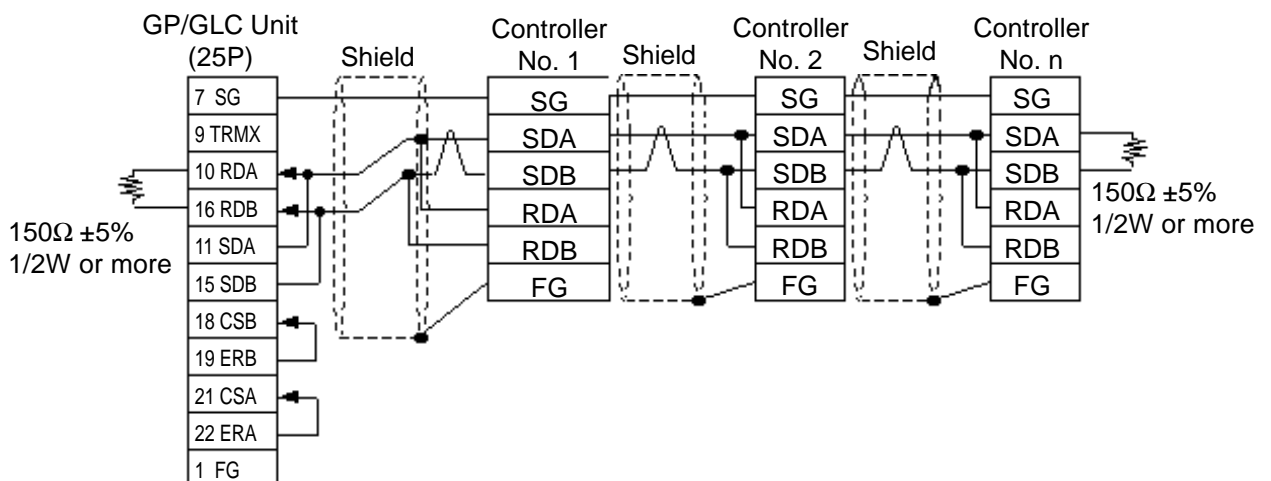

Cable Diagram 6 (1:1) RS-422 2 Wires, RS-422 3 Wires

<When using Digital's RS-422 connector terminal adapter GP070-CN10-0>

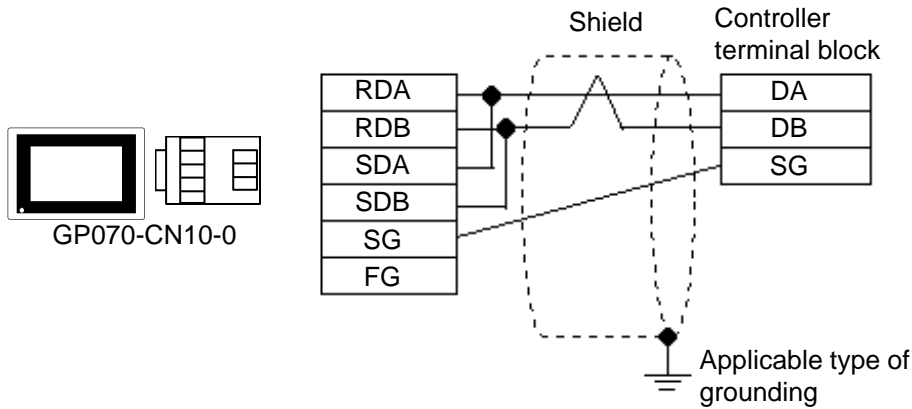

<When preparing your own cable>

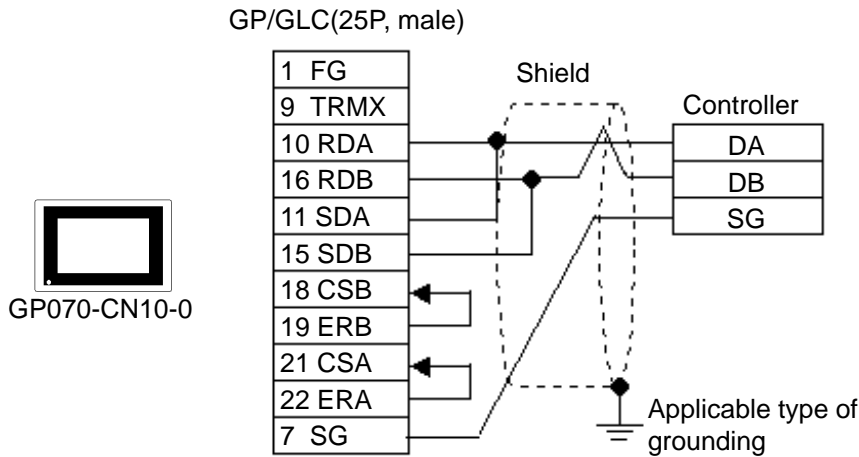

- **Since terminating resistance is provided inside the Controller, DO NOT connect additional terminating resistance.**

Cable Diagram 7 (1:n) RS-422 2 Wires, RS-422 3 Wires

<When using Digital's RS-422 connector terminal adapter GP070-CN10-0>

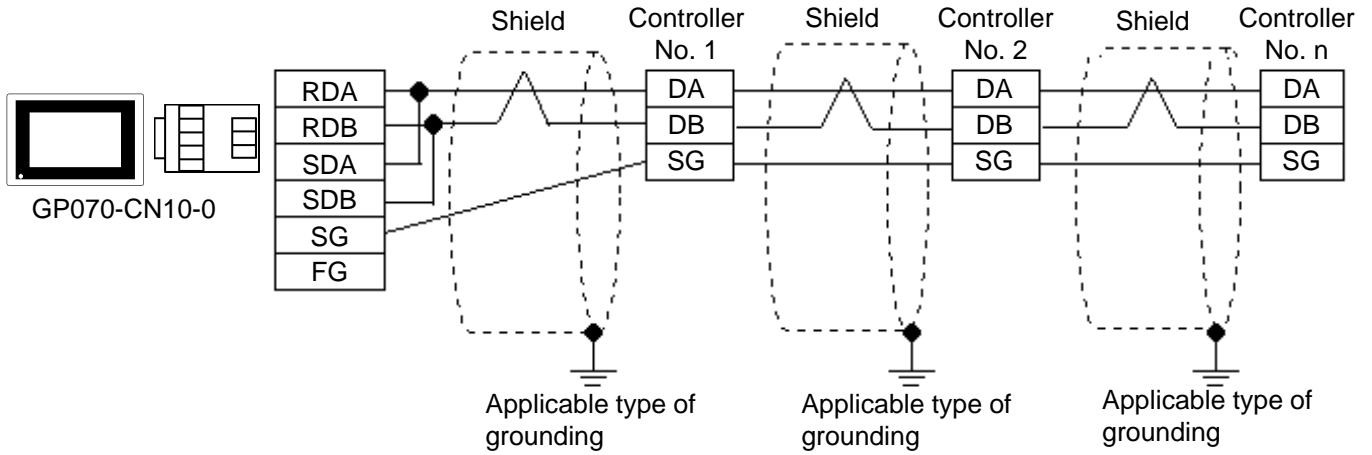

<When preparing your own cable>

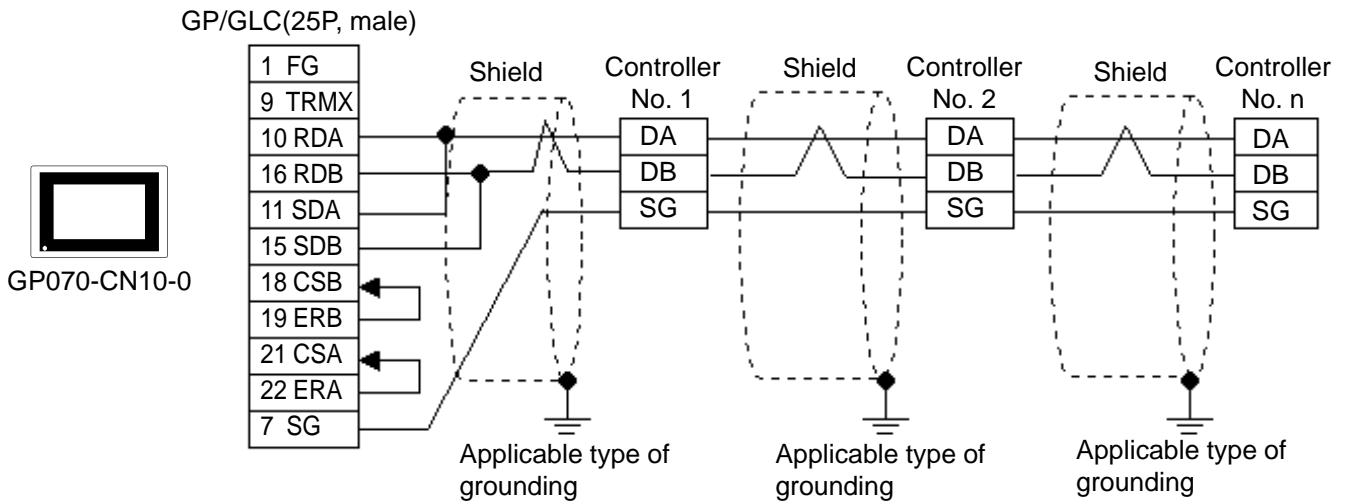

- **Since terminating resistance is provided inside the Controller, DO NOT connect additional terminating resistance.**

12.3.3 Supported Devices

The following lists show the ranges of devices supported by the GP/GLC.

■ Yamatake SDC Series

Device	Bit Address	Word Address	Remarks
Data	00000 ~ 8999F	0000 ~ 8999	H/L

■ Yamatake DMC10*1

Device	Bit Address	Word Address	Remarks
Data	10010 ~ 7804F	1001 ~ 7804	H/L

*1. Data cannot be written or read to some Addresses. For more detailed information, refer to the Yamatake's appropriate Operation manual.



Important

- **GP/GLC's System Data Area (LS0 to LS19) Settings**

The GP/GLC's system area (20 words) cannot be allocated to the Controller's own data area. Even though you can enter the system area settings via the GP screen editor software or via the GP/GLC's OFFLINE screen, it is impossible to actually allocate the system area to the Controller's data area.

- *Be careful that the Device fields differ depending on the type of Controller. Refer to the Controller's manual for the range allowed for the device address area.*

After screen data is converted from a different type of Controller, be sure to check if the device addresses used are correct.

Be sure to check the supported device addresses before using Trend graphs or tags in your screens that use multiple words over continuous addresses.



Note:

- When entering device addresses via the GP screen editor software, the top address (left-most digit) is used for the device name and remaining three digits (0 to 999) are used for the Controller data addresses.
- When settings tags in the screen editor software, the device address can be designated during address input. When a device number is not designated, the previously entered device number is automatically used. (The default value is 1.)

<e.g.> When entering Device Address "6728":

Enter the device name "6", and then the Word Address "728".

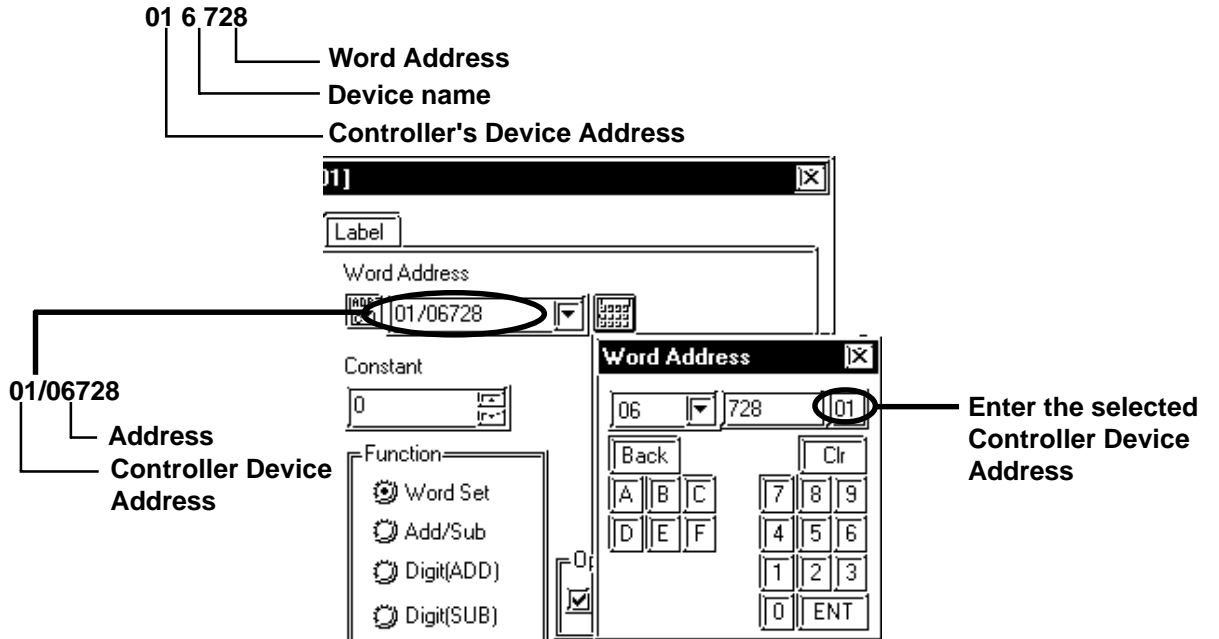

12.3.4 Environment Setup

The following tables show Digital's recommended Controller and GP/PLC communication settings.

■ Yamatake SDC Series

GP Settings		Controller Settings	
Baud Rate	9600bps	Baud Rate	9600bps
Data Length	8bit	Data Length	8bit
Stop Bit	1bit	Stop Bit	1bit
Parity Bit	Even	Parity Bit	Even
Data Flow Control	ER	-----	-----
Communication Format (when using RS-232C *1)	RS-232C	-----	-----
Communication Format (when using RS-422)	4 wires	-----	-----
Communication Format (when using RS-422)	2 wires	-----	-----
Unit No.	Select a desired unit number from 1 to 32.	Device Address	Enter all different Controller device addresses.

*1 RS-232C communication can be performed with SDC20, SDC21, SDC40A, SDC40B, and SDC40G.



- **Although the Controller's device address input range is from 0 to 127, be sure to use only from 1 to 32 on the GP/GLC to match the Controller's device address to the GP's.**
- **When using 1:n communication, up to 31 Controllers can be connected.**
- **When the device address is designated as 0 (default value), communication is not be performed.**

■ Yamatake DMC10

GP Settings		Controller Settings	
Baud Rate	19200bps	Baud Rate	19200bps
Data Length	8bit	Data Length	8bit
Stop Bit	1bit	Stop Bit	1bit
Parity Bit	Even	Parity Bit	Even
Data Flow Control	ER	-----	-----
Communication Format (when using RS-422)	2 wires	-----	-----
Unit No. *2	Select a desired unit number from 1 to 15.	Device Address	Enter all different Controller device addresses (1 to F).

*2 Unit numbers entered on the GLC are decimal numbers.

12.4 RKC INSTRUMENT INC. Controllers

12.4.1 System Structure

The following describes the system configuration used when connecting the GP/GLC to RKC Controller.



- **GP/GLC's System Area (LS0 to LS19) Settings**



The GP/GLC's system area (20 words) cannot be allocated to the Controller's own data area. Even though you can enter the system area settings via the GP's screen creation software or via the GP/GLC's OFFLINE screen, be careful that you do not use the Controller's own data area.

■ **CB Series/SR-Mini Series (1:1 communication)**

Controller	Cable Diagram	Cables	GP
H-PCP-A Z-1021	RS-232C (Cable Diagram 1)	RKC's W-BF-01- XXXX *1	GP Series Units GLC Series Units
	RS-422 (4 wires) (Cable Diagram 2)		
CB100 Z-1021 CB400 Z-1021 CB500 Z-1021 CB700 Z-1021 CB900 Z-1021	RS-422 (2 wires) (Cable Diagram 3)		

*1 XXXX indicates the cable length (mm).

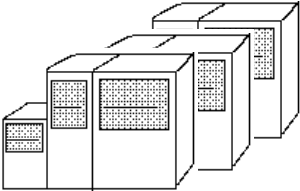
■ **CB Series/SR-Mini Series** (1:n communication)

Controller	Cable Diagram	Cable	GP
			
H-PCP-A Z-1021			RS-422 (4 wires) (Cable Diagram 4)
CB100 Z-1021 CB400 Z-1021 CB500 Z-1021 CB700 Z-1021 CB900 Z-1021	RS-422 (2 wires) (Cable Diagram 5)		GP Series Units GLC Series Units

**1 XXXX indicates the cable length (mm).*

12.4.2 Cable Diagrams

The cable diagrams shown below and the cable diagrams recommended by the RKC INSTRUMENT INC. may differ, however, using these cables for your Controller's operations will not cause any problems.



- **When connecting the FG terminal to the connector cover, be sure that the connector cover conducts current.**
- **Ground your Controller's FG terminal according to your country's applicable standard. For details, refer to your Controller's manual.**
- **When connecting a cable's Shield line to an FG terminal, consider the needs of your system when deciding which side of the cable (GP/GLC or Controller) to connect. (The example below connects to the Controller's FG terminal.)**

■ CB Series



- **Up to 31 CB Series units can be connected to a single GP/GLC.**
- **If a communications cable is used, be sure to connect its SG (signal ground) terminal.**
- **RS-422 (2 wires) cables, must be less than 500 meters long.**
- **The following RS-422 cable is recommended.**

Company	Item No.	Type
Hirakawa Densen	2207-510-008	CO-HC-ESV-3P X 7/0.2



- **The Controller terminal number will differ depending on the type of CPU used. The following examples reflect all the CB series units supported by the Digital Electronics Corporation.**

<CB100, CB400, CB500, CB900>

Terminal No.	Signal Name
13	SG
14	T/R(A)
15	T/R(B)

<CB700>

Terminal No.	Signal Name
7	SG
8	T/R(A)
9	T/R(B)

■ SR-Mini Series



- **Up to 16 SR-Mini Series modules can be connected to a single GP/GLC.**
- **If a communications cable is used, be sure to connect its SG (signal ground) terminal.**
- **RS-232C cables should be less than 15 meters long.**
- **RS-422 (2 wire) cables should be less than 500 meters long.**
- **The following RS-422 cables are recommended for SR-Mini Series units.**

Company	Type	Comments
RKC INSTRUMENT INC.	W-BF-01- XXXX *1	Used when connecting a SR-Mini to a GP/GLC
RKC INSTRUMENT INC.	W-BF-02- XXXX *1	Used when connecting a SR-Min to SR-Mini

*1 XXXX indicates the cable length (mm).

Cable Diagram 1 (1:1) RS-232C

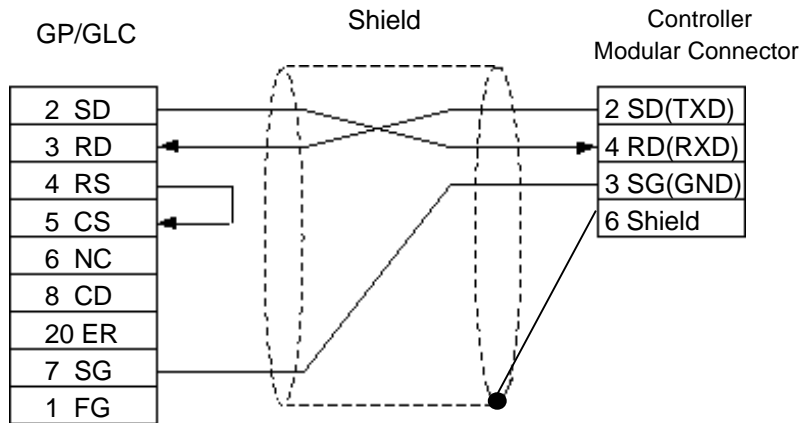

Cable Diagram 2 (1:1) RS-422 4 Wires

<When using Digital's RS-422 connector terminal adapter GP070-CN10-0>

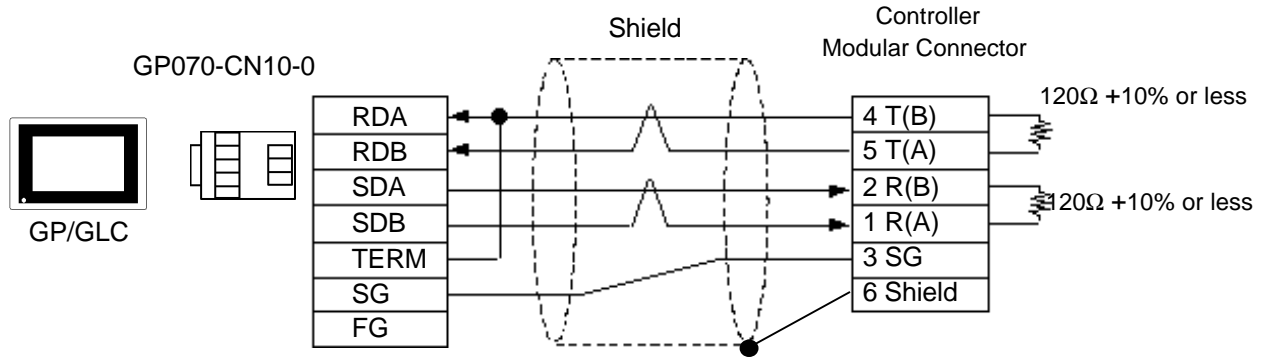

<When making your own cable>

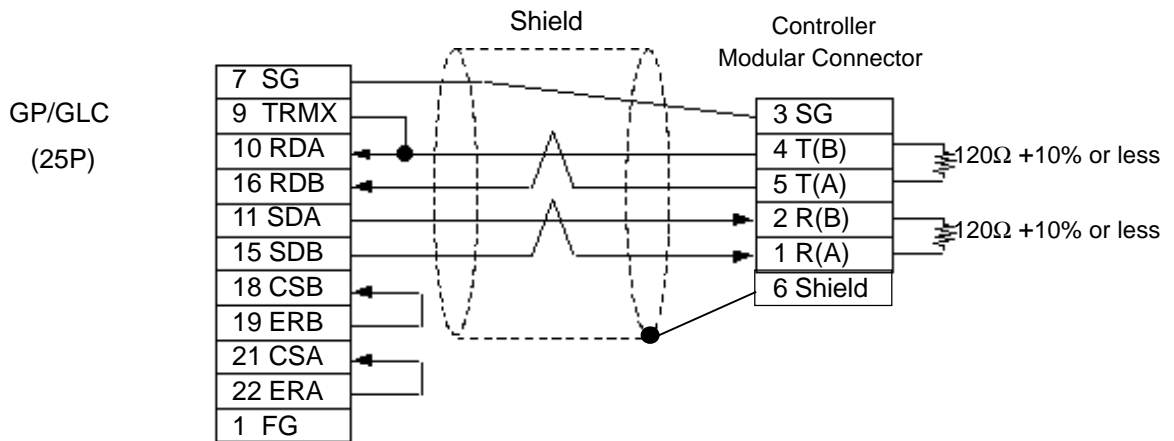

Cable Diagram 3 (1:1) RS-422 2 Wires

<When using Digital's RS-422 connector terminal adapter GP070-CN10-0>

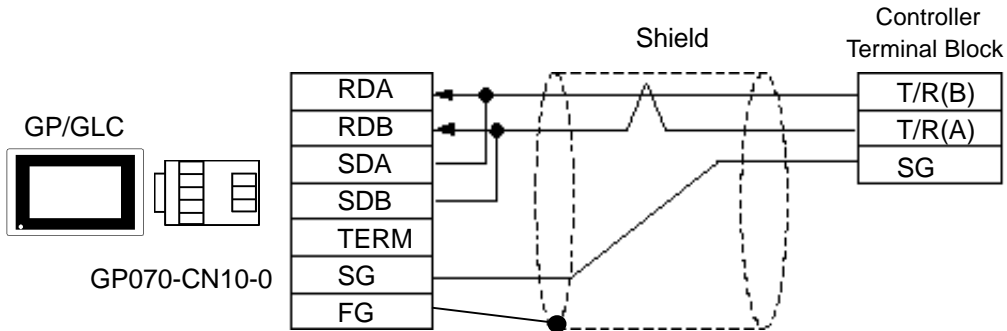

<When making your own cable>

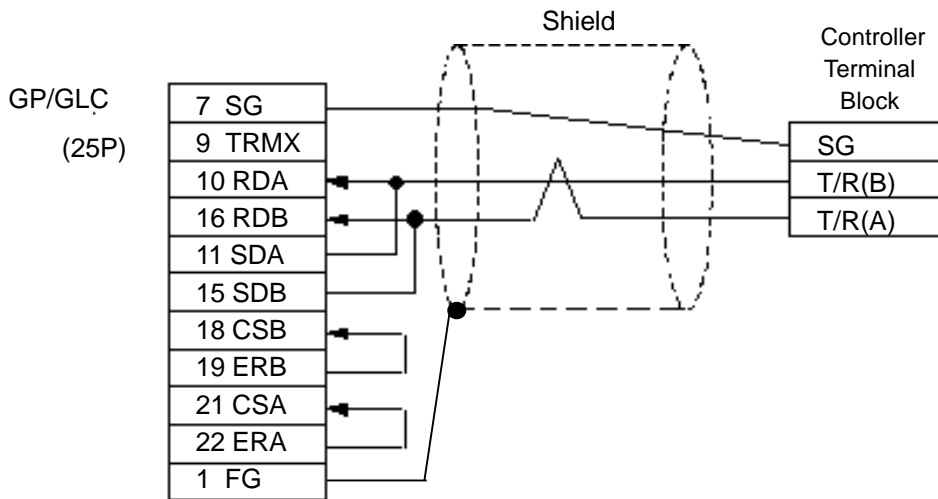

Cable Diagram 4 (1:n) RS-422 4 Wires

<When using Digital's RS-422 connector terminal adapter GP070-CN10-0>

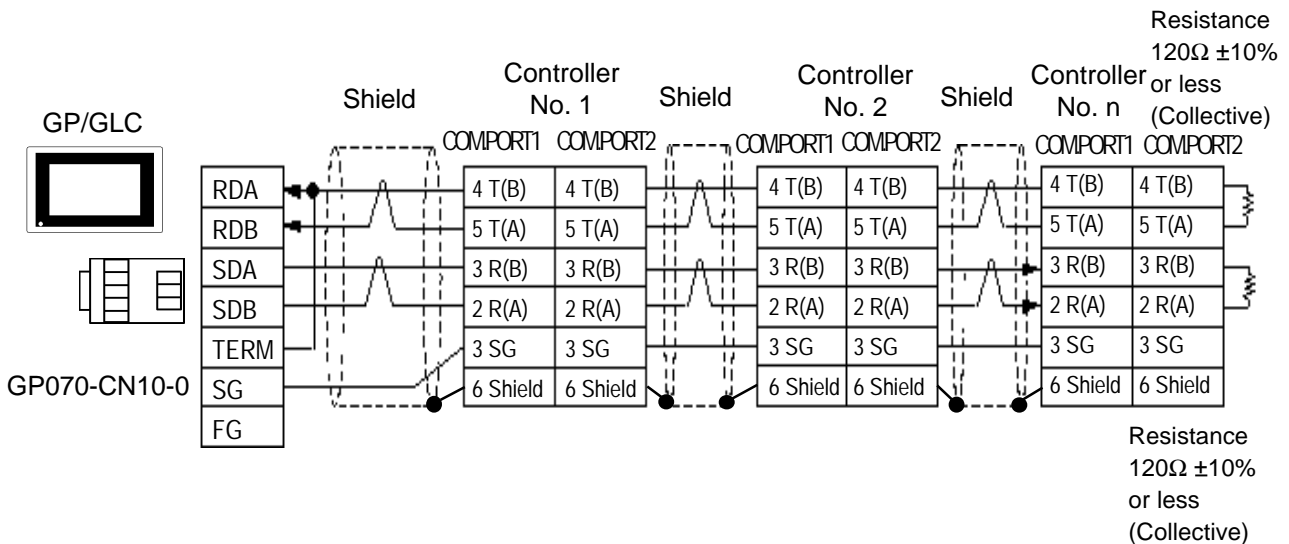

<When making your own cable>

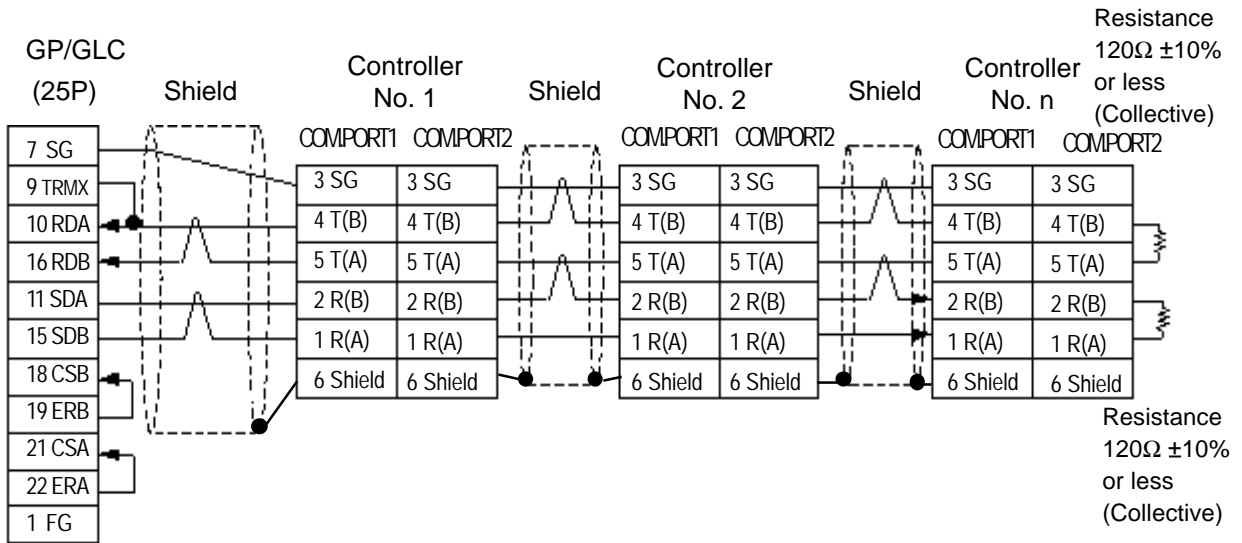

Cable Diagram 5 (1:n) RS-422 2 Wires

<When using Digital's RS-422 connector terminal adapter GP070-CN10-0>

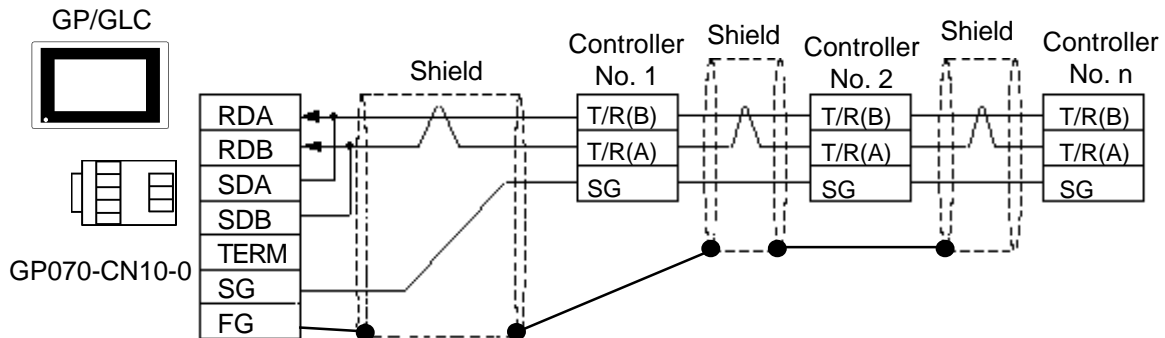

<When making your own cable>

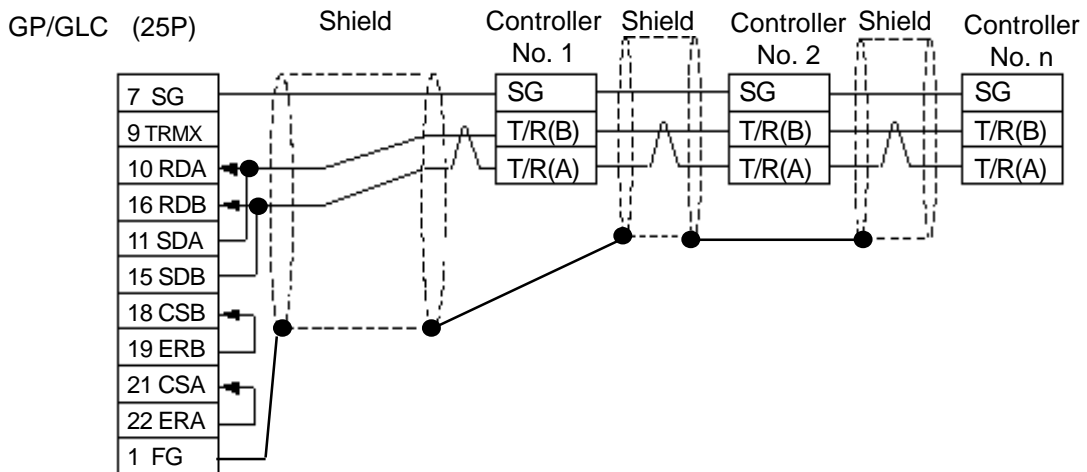

12.4.3 Supported Devices

The following list shows the range of devices supported by the GP/GLC.

■ CB Series

Device	Bit Address	Word Address	Comments
Data	00000 ~ 02EEF	0000 ~ 02EE	H/L



• **GP/GLC's System Area (LS0 to LS19) Settings**

The GP/GLC's system area (20 words) cannot be allocated to the Controller's own data area. Even though you can enter the system area settings via the GP's screen creation software or via the GP/GLC's OFFLINE screen, be careful that you do not use the Controller's own data area.

- *The data communication feature will not operate when the slave address No. is set to "0". (The default value is 0.)*



- **When using tags in the screen editor software, the PLC Station number can be specified during address Input. If a station number is not indicated, the previously entered station number is automatically used. (The default value is 1.)**

E.g. When entering Device Address 02EE

Enter the Device Name "...", and the Word Address "02EE".

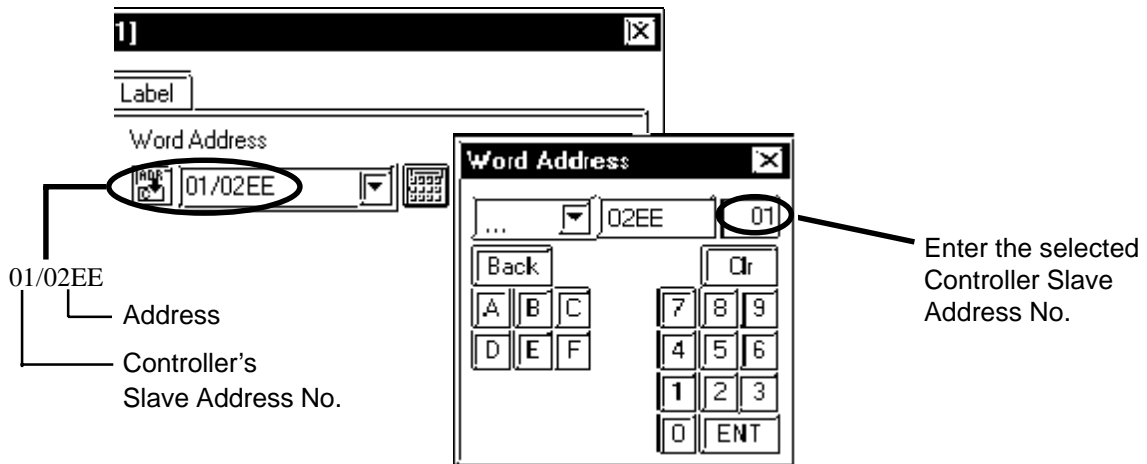
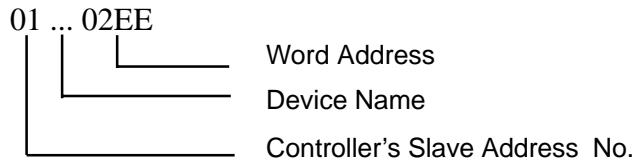

12.4.4 Environment Setup

The following table lists Digital's recommended RKC INSTRUMENT INC. Controller and GP communication settings.

GP Settings		Controller Settings	
Baud Rate	9600 bps	Baud Rate	9600 bps
Data Length	8 bits	Data Length	8 bits
Stop Bit	1 bit	Stop Bit	1 bit
Parity Bit	None	Parity Bit	None
Data Flow control	ER	-----	-----
Communication Format using RS-232C ^{*1}	RS-232C	-----	-----
Communication Format using RS-422 (4-wire) ^{*2}	4-wire type	-----	-----
Communication Format using RS-422 (2-wire)	2-wire type	-----	-----
Unit No.	Select any unit number from 1 to 32.	Slave Address No.	Select any unit number from 1 to 32.

**1 RS-232C can be used when the H-PCP-A (Z-1021) is used.*

**2 Only the H-PCP-A (Z-1021) can use a 4 wire cable, and only CB series units can use a 2 wire cable.*



- **The Controller's slave address number range is from 0 to 99 for the CB series units (the data communication feature does not operate when it is set to "0".) and from 1 to 16 for the SR-Mini series units. Use only from 1 to 32 on the GP/GLC.**
- **With a 1:n connection, up to 31 CB series units, and up to 16 SR-Mini series units can be connected to a single GP.**



12.5 Omron Corporation Controllers

12.5.1 System Structure



The following describes the system configuration used when connecting the GP/GLC to this Controller.



- **GP/GLC's System Area (LS0 to LS19) Settings**

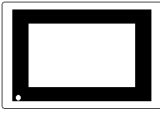

The GP/GLC's system area (20 words) cannot be allocated to the Controller area. Even though you can enter the system area settings via the GP/GLC's screen creation software or via the GP's OFFLINE screen, be careful that you do not actually use the Controller area.

■ THERMAC NEO Electronic Temperature Controller (1:1 communication)

Electronic *1 Temperature Controller	Cable Diagram	GP/GLC
		
E5EN-□□□□□-FLK E5AN-□□□□□-FLK	RS-232C <Cable diagram 1>	
E5EN-□□□□□-FLK E5CN-□□□□□-FLK E5GN-□□□□□-FLK E5AN-□□□□□-FLK	RS-422 (2-wire type) <Cable diagram 2>	(GP or GLC series)

*1 The Controller's model number "□" will vary depending on each controller functionality specifications.

■ THERMAC NEO Electronic Temperature Controller (1:n communication)

Electronic *1 Temperature Controller	Cable Diagram	GP/GLC
		
E5EN-□□□□□-FLK E5CN-□□□□□-FLK E5GN-□□□□□-FLK E5AN-□□□□□-FLK	RS-422 (2-wire type) <Cable diagram 3>	(GP or GLC series)

*1 The Controller's model number "□" will vary depending on each controller functionality specifications.

12.5.2 Cable Diagrams

The cable diagrams shown below and the cable diagrams recommended by Omron Corporation may differ, however, using these cables for your Controller's operations will not cause any problems.



- For an RS-232C cable, use a cable length of less than 15 meters. Also, be sure to connect its SG (signal ground) terminal.
- For an RS-422 cable, use a cable length less than 500 meters.
- Digital recommends the following RS-422 cables.

Recommended RS-422 Cable

No.	Model *1	Standard
1	E5EN-□□□□-FLK, E5CN-□□□□-FLK, E5AN-□□□□-FLK	AWG28 or above
2	E5GN-□□□□-FLK	AWG14 to AWG24

*1 The Controller's model number "□" will vary depending on each controller functionality specifications.

Recommended RS-232C Cable

No.	Model *1	Standard
1	E5EN-□□□□-FLK E5AN-□□□□-FLK	T twisted pair wire with shield, AWG28 or above

*1 The Controller's model number "□" will vary depending on each controller functionality specifications.

Cable Diagram 1 (1:1) RS-232C

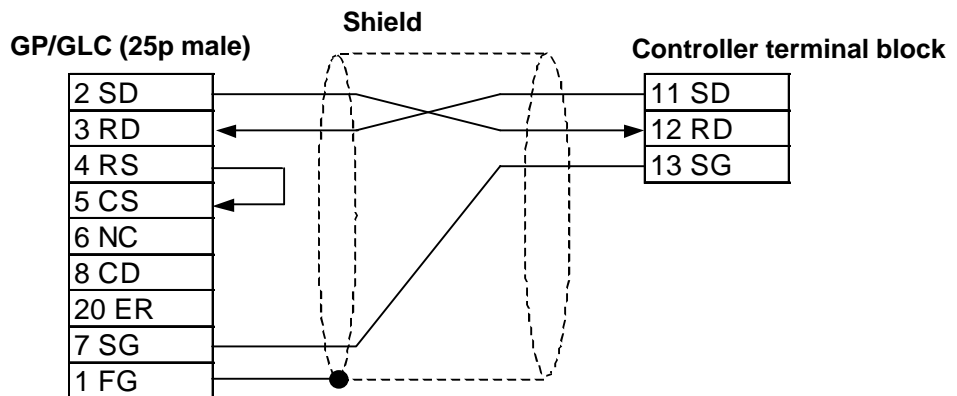

Cable Diagram 2 (1:1) RS-422

The Pin Nos. used with a RS-422 connection will vary depending on the type of controller used. The controller pin assignment diagrams are shown below. Terminal numbers are not shown in the following RS-422 cable diagrams. Refer to the following tables and diagrams when making all wiring connections.

E5EN/E5CN/E5AN

Abbreviation	Pin No.
A(-)	12
B(+)	11

E5GN

Abbreviation	Pin No.
A(-)	6
B(+)	5

<When using Digital's RS-422 connector terminal adapter GP070-CN10-0>

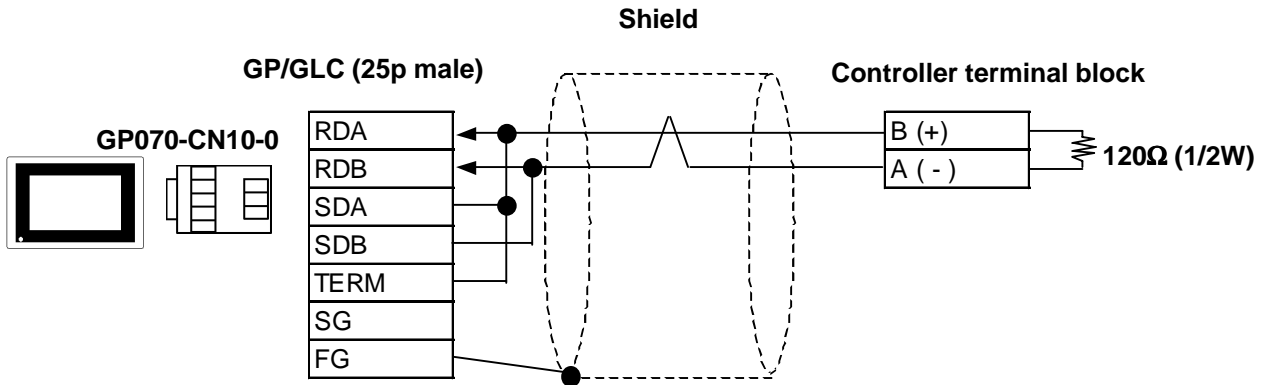

<When using Digital's RS-422 cable, GP230-IS11-0>

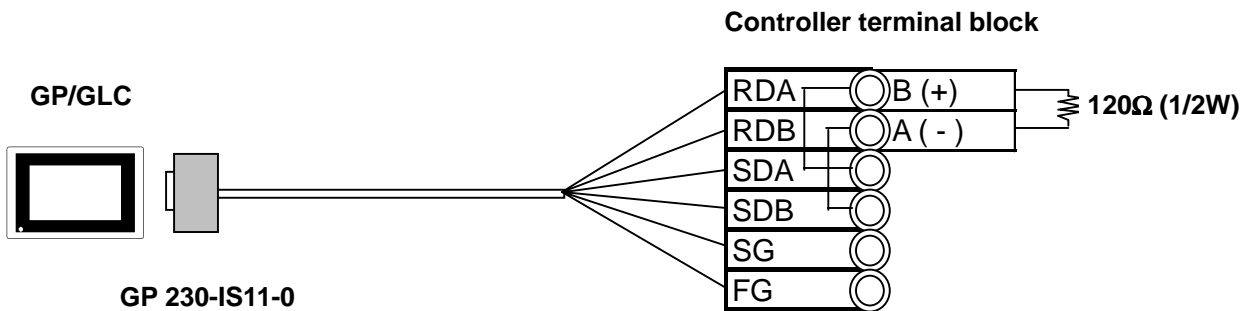

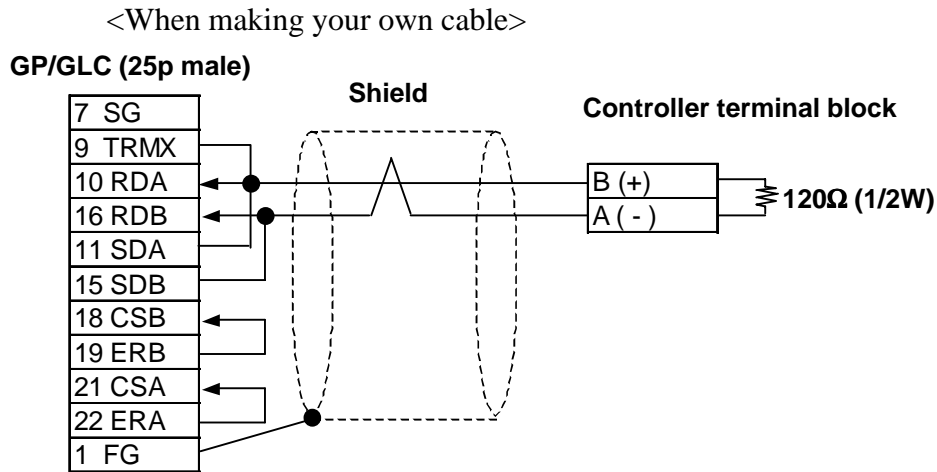

Cable Diagram 3 (1:n) RS-422 2 Wires



- For the shield wire grounding, be sure to use dispersion grounding, parallel grounding or series grounding (shown below), depending on your electrical equipment conditions.

<When using Digital's RS-422 connector terminal adapter GP070-CN10-0>
(An example of series grounding)

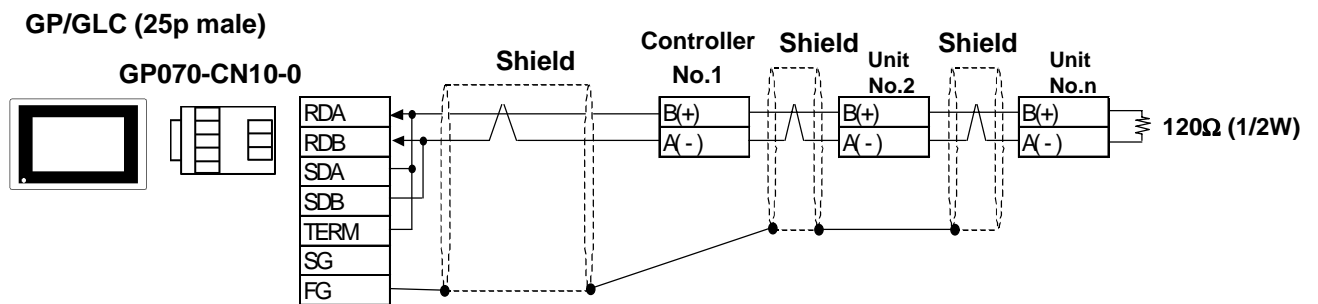

<When using Digital's RS-422 cable, GP230-IS11-0>
(An example of series grounding)

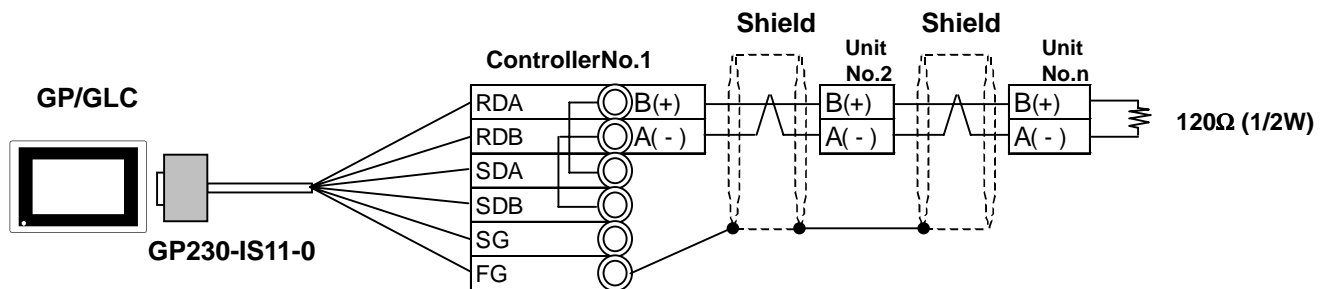

<When making your own cable>
 (An example of series grounding)

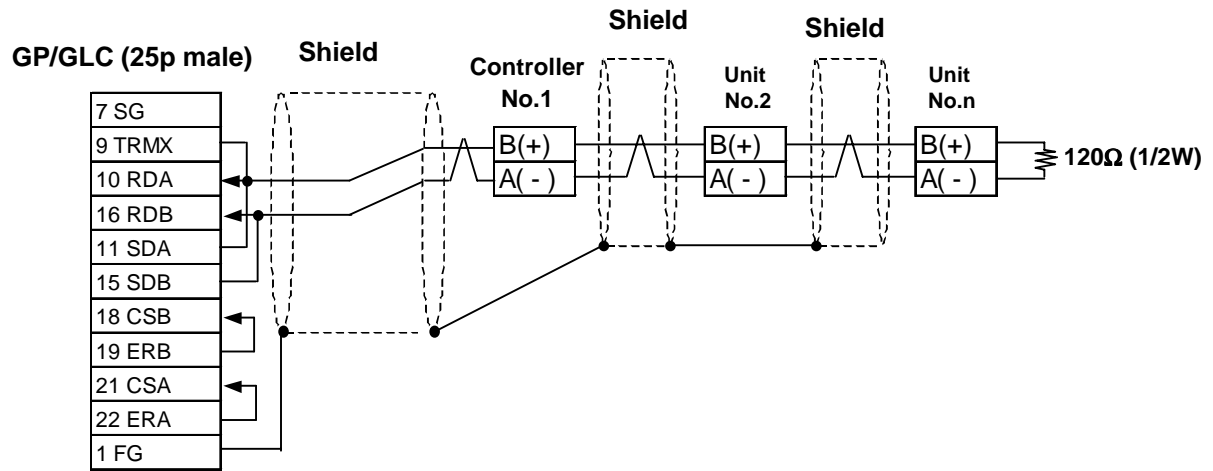

12.5.3 Supported Devices

The following list shows the range of devices supported by the GP/GLC.

■ THERMAC NEO Electronic Temperature Controller

Device	Bit Addresses	Word Addresses	Remarks	
Variable Areas	C0000000 to C0000531	C00000 to C00005	Double word device (write disabled) *1	H/L
	C1000000 to C1001C31	C10000 to C1001C	Double word device	
	C3000000 to C3003531	C30000 to C30035	Double word device	
Operation Commands	A000000 to A000815	A0000 to A0008	Word device	

*1 Data write is not possible.



GP-PRO/PBIII for Windows' Simulation feature is not available with this protocol. To avoid a possible GP/GLC malfunction, do not use this feature.



- **The system area (20 words) of GP/GLC cannot be used. Although it is possible to set addresses for this area with the GP screen editor software, or via the GP/GLC's OFFLINE mode, it is impossible to actually allocate the system area to the controller's data area.**
- **Be careful as the Device fields differ depending on the type of Controller. Refer to the Controller's manual for the range allowed for the device address area.**



- After screen data is converted from a different type of Controller, be sure to check if the device addresses used are correct.
- Be sure to check that the device addresses are supported before using. Trend graphs or tags in your screens which use multiple words over continuous addresses.
- When using the GLC, Pro-Control Editor Ver. 2.0 or higher is required.
- When using Pro-Server Ver. 2.0, be careful about the following points.
 - 1) The Status Monitor feature cannot be used to monitor Tag scan time, communication cycle time, token circulation speed maximum/minimum values, and communication error codes.
 - 2) LS devices cannot be monitored or written to.



- This protocol's LS area uses a 32-bit device.
- When setting Tags in the screen editor software, the Controller communication unit No. can be specified during address input. If a communication unit No. is not indicated, the previously entered communication unit No. is automatically used. (The default value is 1.)

E.g. When entering Device Address C00000

Enter the Device Name "C0", and the Word Address "0000".

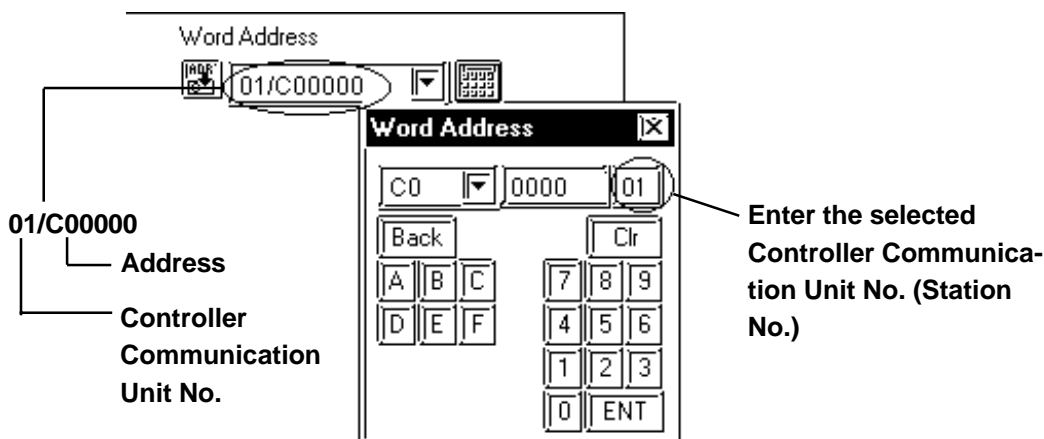
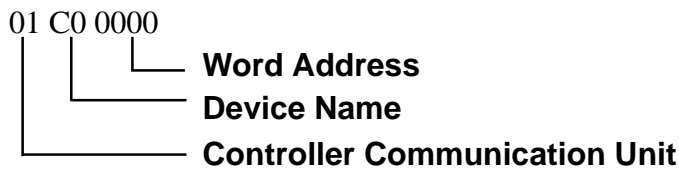

- After the Controller's power is turned ON, it may take a few seconds until the Controller starts. Therefore, if the GP/GLC and the Controller are turned ON at the same time, there may be a delay of several seconds until communication starts.

■ Operation Commands

Command codes 00 to 08 are used for operation command service (command) to provide a total of 9 write commands.

Certain command operations are identical, and the result (arbitrary value) is written to a variable area.

Device code	Word address	Command code	Meaning
A	0000	00	Data Transfer Write
	0001	01	RUN / STOP
	0002	02	Multi-SP
	0003	03	AT RUN / STOP
	0004	04	Write mode
	0005	05	Store RAM data
	0006	06	Software reset
	0007	07	Setting area shift 1
	0008	08	Protection level shift



- When a write command is performed, the device code used in the screen creation software is 'A', and that command code is entered instead of the device address.

Related data (2 bytes) is designated by each write tag's setting value. Since this device is a write-only device, readout is disabled. If used for readout, i.e. an N-tag, a host communication error (02:F0:**) (** is set tag unit No.) will appear in the lower left corner of the GP/GLC screen.

- Device "C0, C1, C3"
C0, C1 and C3 devices are not used as device symbols. Instead they identify a variable area's data type.

Reference User Manual (SGTD-706) for OMRON's E5AN/E5EN/E5CN/E5GN Electronic Temperature Controller

■ GP/GLC Error Codes

Error codes are indicated in the left lower corner of the GP/GLC screen.

Error codes consist of three types. When an error occurs, the corresponding error code and GP station number (where the error occurred) are saved either in LS2039 or LS2070. Since the method used will vary depending on the error type, refer to the following list for details. (Data saved in LS2039 or LS2070 is shown using hexa-decimal characters.)

1. Error Code (02:12) – 2 units

Error Code	0x12
Data saved in LS2039	0x12 (error code)
Data saved in LS2070	0 (fixed as "0")

2. Error Code (02:12:34) – 3 units
- | | |
|----------------------|---|
| Error Code | 0x12. The GP station number where the error occurred is 34(0x22) |
| Data saved in LS2039 | 0x1222 (The two digits shown here by “12” represent the error code, and the last two digits “22” represent the station no. Note that “0x” is not shown on the display.) |
| Data saved in LS2070 | 0 (fixed as “0”) |
3. Error Code (02:12:34:56) – 4 units
- | | |
|----------------------|---|
| Error Code | 0x1234. The GP unit number where the error occurred is 56(0x38) |
| Data saved in LS2039 | 0x1234 (error code) |
| Data saved in LS2070 | 0x38 (station no.) |

12.5.4 Environment Setup

The following table lists the recommended Controller and GP/GLC communication settings.

■ THERMAC NEO Controller

GP/GLC Settings		Controller Settings	
Baud Rate	9600 bps	Baud Rate	9600 bps
Data Length	7 bits	Data Length	7 bits
Stop Bit	2 bit	Stop Bit	2 bit
Parity Bit	Even	Parity Bit	Even
Data Flow control	ER	-----	-----
Communication Format (using RS-232C) ^{*1}	RS-232C	-----	-----
Communication Format (using RS-422 - 4-line)	4 wire type	-----	-----
Communication Format (using RS-422 - 2-line)	2 wire type	-----	-----
Unit No. ^{*2}	1 to 32	Unit No.	1 to 32

**1 The E5EN and the E5AN use an RS-232C connection.*

**2 It is possible to set a Controller communication unit No. from 0 to 99, however, the GP/GLC can only be set from 1 to 32.*

With a 1:n connection, up to 31 controllers can be connected to a single GP.



12.6 Shinko Technos Corporation Controllers

12.6.1 System Structure

The following describes the system configuration used when connecting the GP/GLC to this Controller.



- **Do not use the system area because the GP/GLC's system area (LS0 to LS19) cannot be allocated to the Controller area. (Deselect all system area selection items.)**
- **The Controller's read area can be used as normal.**

■ C Series

CPU	Control Unit*1	Cable Diagram	Cables	GP
CPT-20A	CCT-235-2-□□	RS-422 <Cable Diagram 4>	CPM Shinko Technos Corporation	GP series GLC series
		RS-422 (1:n) <Cable Diagram 5>	CPM and CPP Shinko Technos Corporation	

*1 The Controller's model number "□□" changes, according to the options selected . For details about model numbers, refer to the C Series catalog.

■ FC Series

Controller *1	Link I/F	Cable Diagram	GP
FCD-13A□□,C FCD-15A□□,C FCR-13A□□,C FCR-15A□□,C	Serial Communication Option:C	RS-232C <Cable Diagram 1>	GP Series GLC Series
FCD-13A□□,C5 FCD-15A□□,C5 FCR-13A□□,C5 FCR-15A□□,C5	Serial Communication Option:C5	RS-422 <Cable Diagram 2> RS-422 (1:n) <Cable Diagram 3>	

*1 The Controller's model number "□□" changes, according to the options selected .

Items with the serial communication option have a ",C" or ",C5" after the basic model number.

For details about model numbers, refer to each series catalog.

■ **FIR Series**

Controller *1	Link I/F	Cable Diagram	GP
FIR-201-M□□,C FIR-201-M□□,C	Serial Communication Option:C	RS-232C <Cable Diagram 1>	GP Series GLC Series
FIR-201-M□□,C5 FIR-201-M□□,C5	Serial Communication Option:C5	RS-422 <Cable Diagram 2> RS-422 (1:n) <Cable Diagram 3>	

■ **GC Series**

Controller *1	Link I/F	Cable Diagram	GP
GCS-300□□,C5	Serial Communication Option:C5	RS-422 <Cable Diagram 2> RS-422 (1:n Communication) <Cable Diagram 3>	GP Series GLC Series

■ **FCL Series**

Controller *1	Link I/F	Cable Diagram	GP
FCL-13A□□,C5	Serial Communication Option:C5	RS-422 <Cable Diagram 2> RS-422 (1:n Communication) <Cable Diagram 3>	GP Series GLC Series

■ **PC-900 Series**

Controller *1	Link I/F	Cable Diagram	GP
PC-935□□,C PC-955□□,C	Serial Communication Option:C	RS-232C <Cable Diagram 1>	GP Series GLC Series
PC-935□□,C5 PC-955□□,C5	Serial Communication Option:C5	RS-422 <Cable Diagram 2> RS-422 (1:n Communication) <Cable Diagram 3>	

*1 The Controller's model number "□□" changes, according to the options selected.
Items with the serial communication option have a "C" or "C5" after the basic model number.
For details about model numbers, refer to each series catalog.

◆ When connecting an RS-232C cable (for RS232C compatible Controllers)

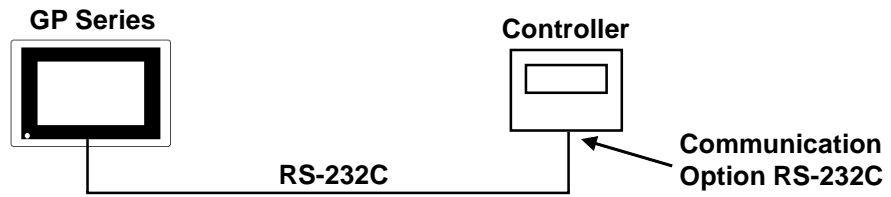

◆ RS-485 cable (except the C Series Controller)

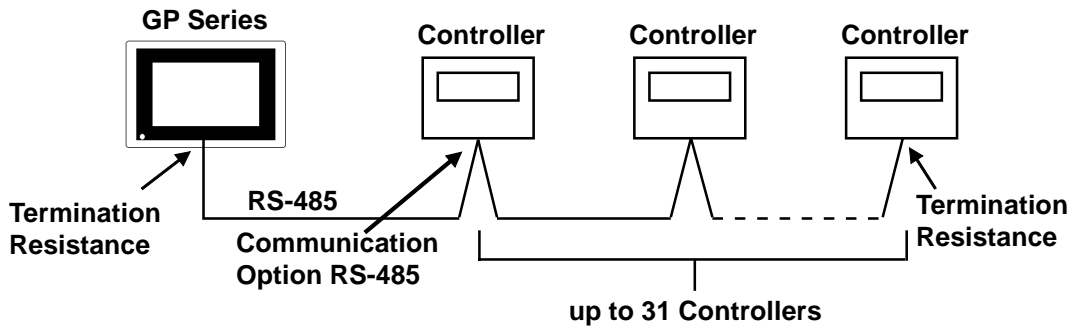

◆ RS-485 cable (connecting with the C Series Controller)

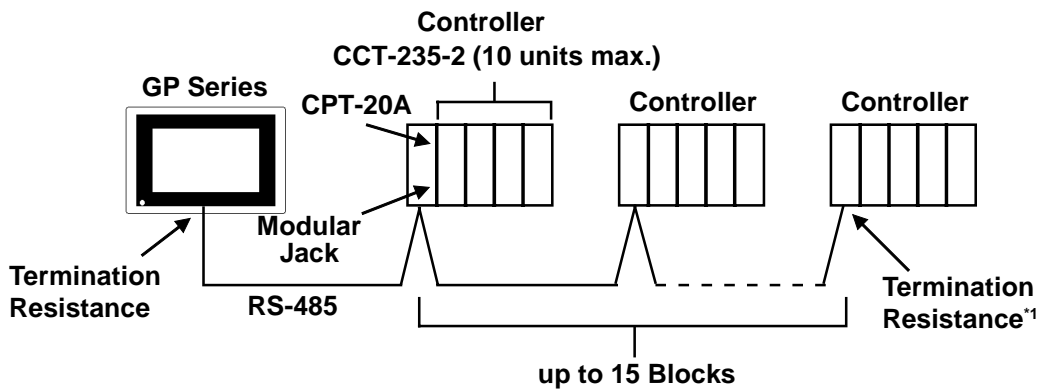

*1 Turn Controller's termination resistance switch ON.

12.6.2 Cable Diagrams

The cable diagrams shown below and the cable diagrams recommended by Shinko Technos Corporation may differ, however, using these cables for your Controller's operations will not cause any problems.



- **Ground your PLC's FG terminal according to your country's applicable standard.**
- **Since some Controllers do not have a GND signal (FG), be careful when selecting the side (GP or Indicating Controller) used for connecting the FG wire to the shield.**
- **When connecting the FG wire to the cable connector's cover, be sure it is made from a conductive material.**
- **For an RS-232C cable, use a cable length of 15 meters or less.**
- **For an RS-422 cable, use a cable length of 600 meters or less.**
- **Digital recommends the OTSC-2PVB-7/0.32TA cable, made by O-NAMBA Corporation.**

Cable Diagram 1

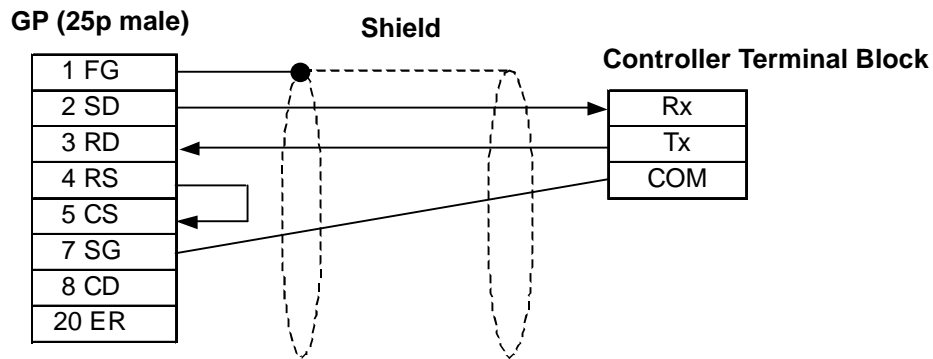

Cable Diagram 2

There are two ways of connecting the GP and the Controller. One is using the Shinko Technos' RS-232C ↔ RS-485 Converter (IF-300-C5). The other is using an RS-485 cable.

<When using Shinko Technos's RS-232C ↔ RS-485 Converter (IF-300-C5)>

When using this converter, be sure the GP's communication setting is "RS-232C".

Do not use any other manufacturer's converter.

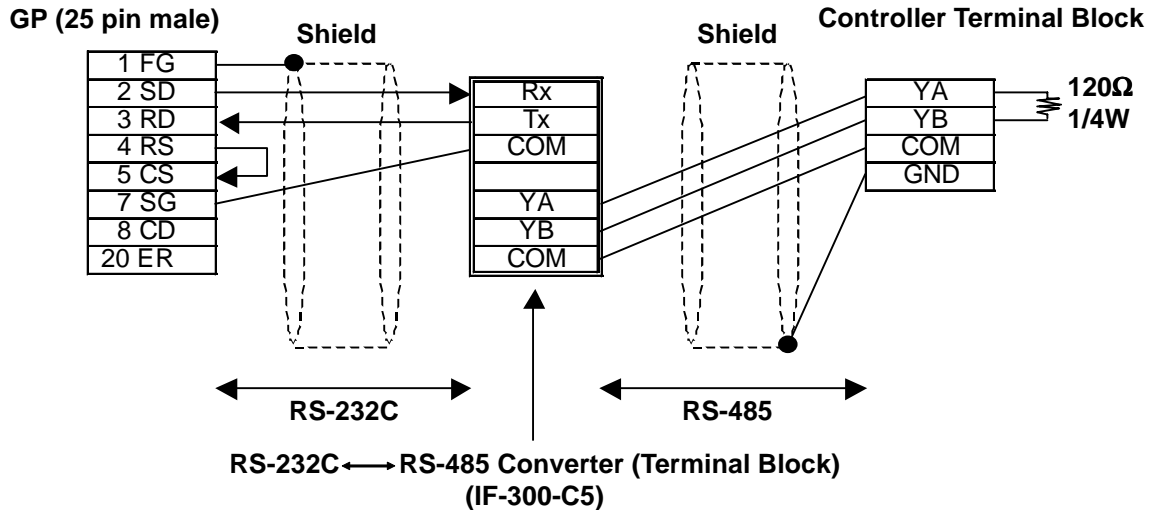

<When connecting the GP and the Controller with RS-485 cable>

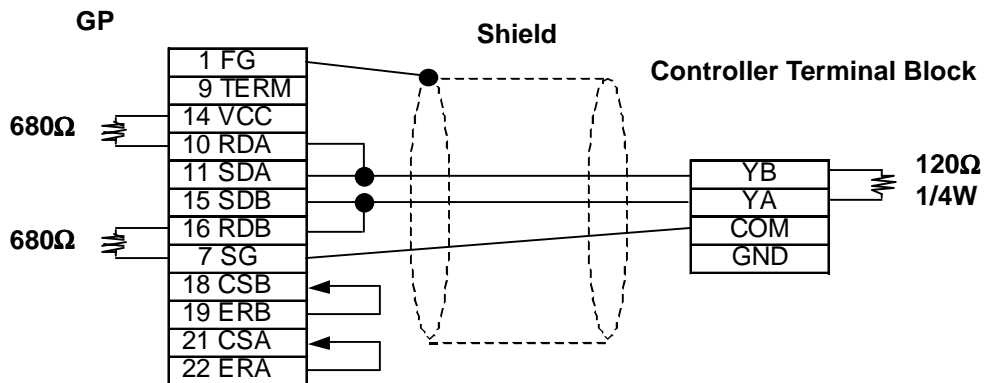

Cable Diagram 3

There are two ways of connecting the GP and the Controller. One is using the Shinko Technos' RS-232C ↔ RS-485 Converter (IF-300-C5). The other is using an RS-485 cable.

<When using Shinko Technos's RS-232C ↔ RS-485 Converter (IF-300-C5)>

When using this converter, be sure the GP's communication setting is "RS-232C".

Do not use any other manufacturer's converter.

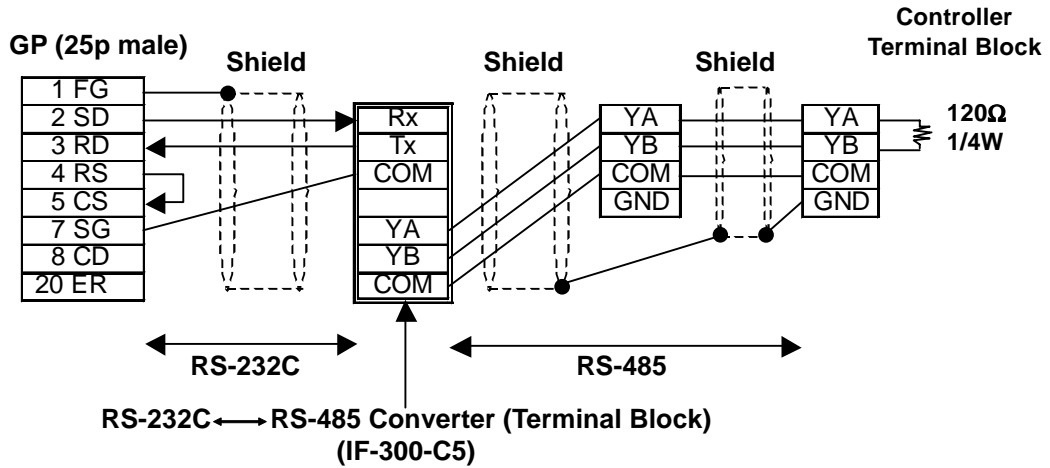

<When connecting the GP and the Controller via RS-485 cable>

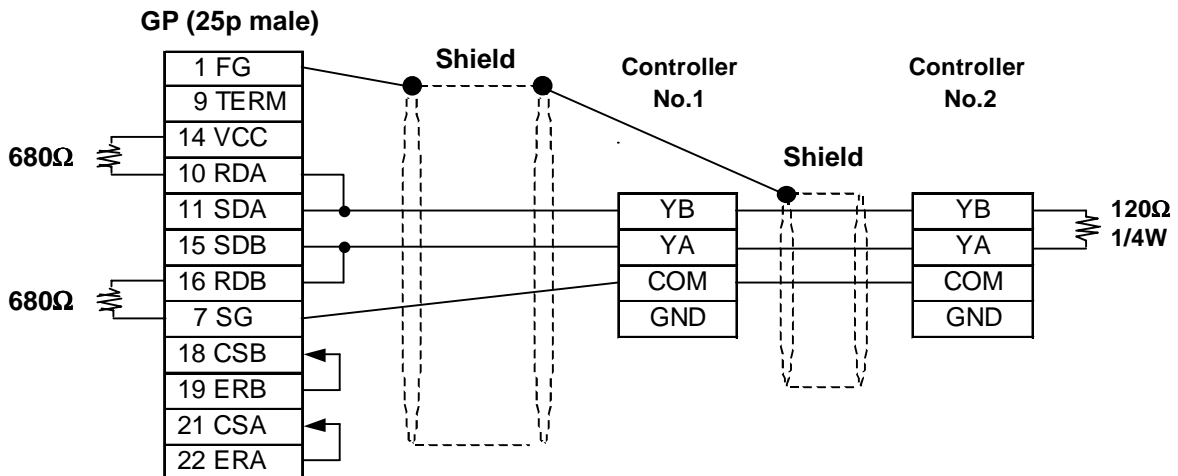

Cable Diagram 4 (RS-422)

<When using Digital's RS-422 connector terminal adapter GP070-CN10-0>

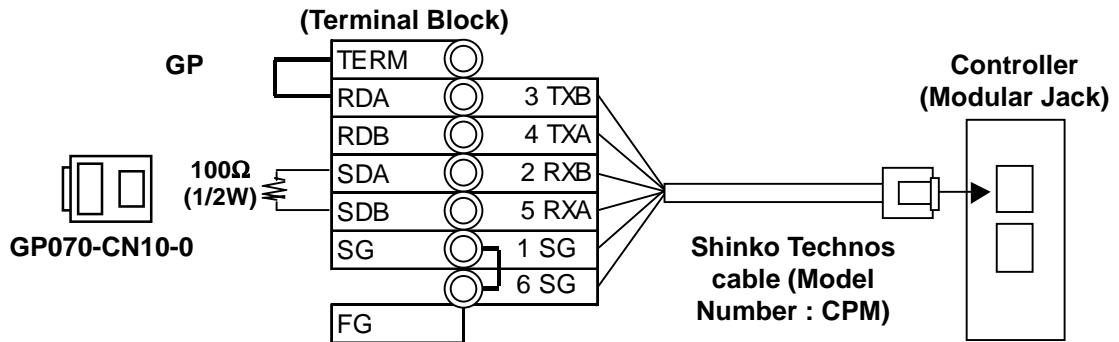

Note: • Be sure to use only the Shinko Technos Corporation “CPM” cable.

Cable Diagram 5 (RS-422)

<When using Digital's RS-422 connector terminal adapter GP070-CN10-0>

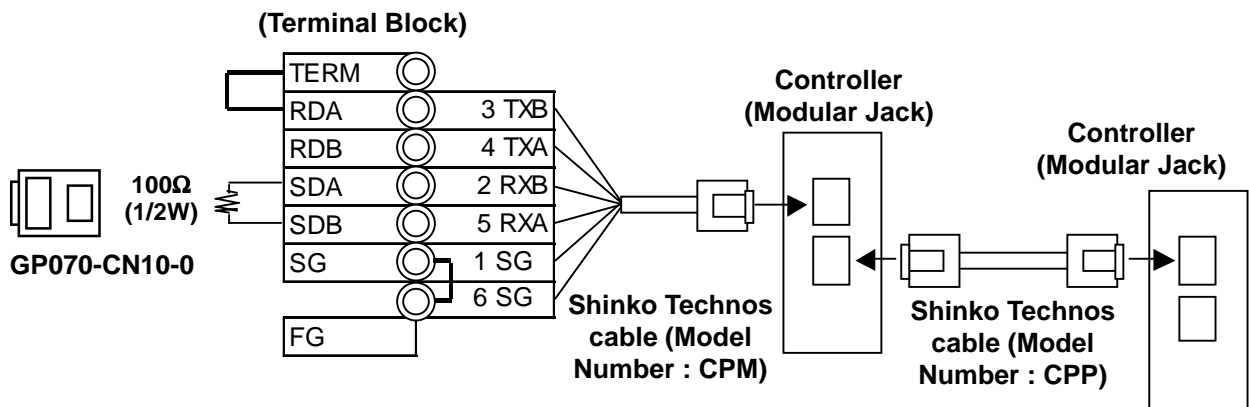

Note: Be sure to use only the Shinko Technos Corporation “CPM” and “CPP” cables.
 Be aware the A and B signals of the GP and PLC are reversed.
 To enable the Controller’s termination resistance, turn dip switch No.2 ON.

12.6.3 Supported Devices

The following list shows the range of devices supported by the GP/GLC.

■ C Series

Device	Bit Addresses* ¹	Word Addresses* ¹	
Channel 1	1CH010 ~ 1CH84F	1CH01 ~ 1CH84	H/L
Channel 2	2CH010 ~ 2CH84F	2CH01 ~ 2CH84	
Channel 3	3CH010 ~ 3CH84F	3CH01 ~ 3CH84	
Channel 4	4CH010 ~ 4CH84F	4CH01 ~ 4CH84	
Channel 5	5CH010 ~ 5CH84F	5CH01 ~ 5CH84	
Channel 6	6CH010 ~ 6CH84F	6CH01 ~ 6CH84	
Channel 7	7CH010 ~ 7CH84F	7CH01 ~ 7CH84	
Channel 8	8CH010 ~ 8CH84F	8CH01 ~ 8CH84	
Channel 9	9CH010 ~ 9CH84F	9CH01 ~ 9CH84	
Channel 10	10CH010 ~ 10CH84F	10CH01 ~ 10CH84	
Channel 11	11CH010 ~ 11CH84F	11CH01 ~ 11CH84	
Channel 12	12CH010 ~ 12CH84F	12CH01 ~ 12CH84	
Channel 13	13CH010 ~ 13CH84F	13CH01 ~ 13CH84	
Channel 14	14CH010 ~ 14CH84F	14CH01 ~ 14CH84	
Channel 15	15CH010 ~ 15CH84F	15CH01 ~ 15CH84	
Channel 16	16CH010 ~ 16CH84F	16CH01 ~ 16CH84	
Channel 17	17CH010 ~ 17CH84F	17CH01 ~ 17CH84	
Channel 18	18CH010 ~ 18CH84F	18CH01 ~ 18CH84	
Channel 19	19CH010 ~ 19CH84F	19CH01 ~ 19CH84	
Channel 20	20CH010 ~ 20CH84F	20CH01 ~ 20CH84	

*1 Input all addresses in hexadecimal characters.



Note: The GP processes all Controller data items in the same way.

Designating an address means that the data item number specifies the address.

For information about data item types and numbers, refer to the Multi Point Temperature Control Unit C Series Guide “Communication Command List”, made by Shinko Technos Corporation.

The following data item list is mentioned in the C Series communication guide for each channel. The C Series supports up to 20 channels.

Command Type	Data Item	Data
20H/50H	0001H : Main setting value (SV) setting	Setting Value
20H/50H	0002H : Main proportional band setting	Setting Value
20H/50H	0003H : Integral time setting	Setting Value
20H/50H	0004H : Derivative time setting	Setting Value
.	:	:

The item Nos. here are the GP addresses.

20H:Read command can be performed.
50H:Write command can be performed.

- When the channel 1 data item is “the setting of main setting value (SV)”, the item No. is “0001H”, and the GP’s address is the following:

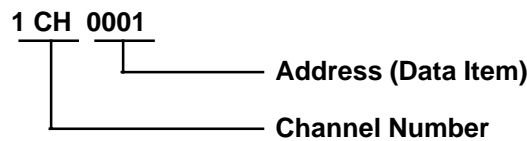

- The channel 1 data item “the integrated time setting”, has an item number of “0003H”, and the GP address is “1CH0003”.
- The channel 2 data item “the integrated time setting” has an item number of “0003H”, and the GP address is “2CH0003”.
- When the command type is 20H, data read can be performed. When it is 50H, data write can be performed.
(20H/50H are used to perform read and write.)

■ FC Series

Device	Bit Addresses*1	Word Addresses*1	
Data Item	00010 ~ 0086F	0001 ~ 0086	H/L
Setting Value Memory 1	1S010 ~ 1S86F	1S01 ~ 1S86	
Setting Value Memory 2	2S010 ~ 2S86F	2S01 ~ 2S86	
Setting Value Memory 3	3S010 ~ 3S86F	3S01 ~ 3S86	
Setting Value Memory 4	4S010 ~ 4S86F	4S01 ~ 4S86	
Setting Value Memory 5	5S010 ~ 5S86F	5S01 ~ 5S86	
Setting Value Memory 6	6S010 ~ 6S86F	6S01 ~ 6S86	
Setting Value Memory 7	7S010 ~ 7S86F	7S01 ~ 7S86	

*1 Input all addresses in hexadecimal characters.



- The GP processes all Controller data items in the same way.
- Designating an address means that the data item number specifies the address.
- For information about data item types and numbers, refer to the FC Series Communication (Option : C,C5) Guide “Communication Command List”, made by Shinko Technos Corporation.

The following data item list is mentioned in the FC Series communication guide for each channel. When the command type is 20H, data read can be performed. When it is 50H, data write can be performed.

(20H/50H are used to perform read and write.)

Contents	Sub Addresses	Command Classification	Data Items
Main setting value or step temperature setting value	1 to 7	20H/50H	0001H
Setting value memory number or step number selection	0	20H/50H	0002H
PID auto-tuning Performance / Cancellation	0	20H/50H	0003H
Proportional band setting	1 to 7	20H/50H	0004H
:	:	:	:

Sub Addresses (Setting Memory No.)

The item No. here is the GP addresses

When using the FC Series, the sub addresses must be selected. Here, “sub addresses” mean “the setting value memory No.”. For example, “sub address 1” means “setting value memory No.1”. The data items, that the sub addresses are needed to be set, therefore, are needed to be specified the device of “setting value memory *”.

Data items with the sub addresses that do not need to be set (when the sub address is 0), can specify only the number of data items.

E.g. Data items with the sub addresses that do not need to be set.

When setting value memory No.1, GP address data items (the main setting value, “step temperature setting value”) are as follows:

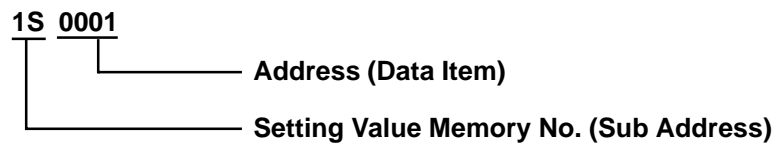

E.g. Data items with the sub addresses that do not need to be set.
 GP address data items (the setting value memory number selection, “step numbers”) are as follows:



■ FIR/GC/FCL Series

Device	Bit Addresses*1	Word Addresses*1	
Data Item	00010 ~ 00A3F	0001 ~ 00A3	H/L

*1 Input all addresses in hexadecimal characters.



- The GP processes all Controller data items in the same way.
- Designating an address means that the data item number specifies the address.
- For information about data item types and numbers, refer to the FIR-201-M Communication Guide “Communication Command List”, GCS-300 Communication Guide “Communication Command List”, and “FCL-13A Communication Guide “Communication Command List”, made by Shinko Technos Corporation.

The following data item list is mentioned in the FIR Series communication guide for each channel. When the command type is 20H, data read can be performed. When it is 50H, data write can be performed.

(20H/50H allow read and write to be performed.)

Command Type	Data Item	Data
20H/50H	0001H : Alarm 1 (A1) Setting	Setting Value
20H/50H	0002H : Alarm 2 (A2) Setting	Setting Value
20H/50H	0003H : Alarm 3 (A3) Setting	Setting Value
20H/50H	0004H : Setting Value Lock Designation	Setting Value
:	:	:

The item Nos. here are the GP addresses.

20H:Read command can be performed.
 50H:Write command can be performed.

- For the data item “Alarm 1 (A1) Setting”, the item number is 0001H. As a result, the GP address is as follows:



- For the data item “Alarm 2 (A2) Setting”, the item number is 0002H. As a result, the GP address is “0002”.

■ PC-900 Series

Device	Bit Addresses	Word Addresses	Remarks	
Data Items	00010 ~ 0400F	0001 ~ 0400	*2	H/L
	04010 ~ 0800F	0401 ~ 0800		
	08010 ~ 0C00F	0801 ~ 0C00		
	0C010 ~ 1000F	0C01 ~ 1000		
	10010 ~ 1400F	1001 ~ 1400		
	14010 ~ 1800F	1401 ~ 1800		
	18010 ~ 1C00F	1801 ~ 1C00		
	1C010 ~ 2000C	1C01 ~ 2000		
	20010 ~ 2400F	2001 ~ 2400		
	24010 ~ 2800F	2401 ~ 2800		
	28010 ~ 2C00F	2801 ~ 2C00		
	2C010 ~ 3000F	2C01 ~ 3000		
	30010 ~ 3400F	3001 ~ 3400		
	34010 ~ 3800F	3401 ~ 3800		
	38010 ~ 3C00F	3801 ~ 3C00		
	3C010 ~ 4000F	3C01 ~ 4000		
	40010 ~ 4400F	4001 ~ 4400		
	44010 ~ 4800F	4401 ~ 4800		
	48010 ~ 4C00F	4801 ~ 4C00		
	4C010 ~ 5000F	4C01 ~ 5000		
	50010 ~ 5400F	5001 ~ 5400		
	54010 ~ 5800F	5401 ~ 5800		
	58010 ~ 5C00F	5801 ~ 5C00		
	5C010 ~ 6000C	5C01 ~ 6000		
	60010 ~ 6400F	6001 ~ 6400		
	64010 ~ 6800F	6401 ~ 6800		
	68010 ~ 6C00F	6801 ~ 6C00		
	6C010 ~ 7000C	6C01 ~ 7000		
	70010 ~ 7400F	7001 ~ 7400		
	74010 ~ 7800F	7401 ~ 7800		
	78010 ~ 7C00F	7801 ~ 7C00		
	7C010 ~ 7991F	7C01 ~ 7991		

*1 Input all addresses in hexadecimal characters.

*2 The data items are internally processed, with each “block” being divided into 1024 words (0x400). Therefore, be aware of that the following functions cannot be used with settings that cross a block (1024 words). Be sure to set the data items within one block when using this series unit.

- 1) “a” tag setting
(alarms will not displayed)
- 2) Block Read - using the 2-way function
(Only the maximum number of addresses in the selected block will be displayed.)



- Note:**
- The GP processes all Controller data items in the same way.
 - Designating an address means that the data item number specifies the address.
 - For information about data item types and numbers, refer to the PC-935, PC-955 communication (option : C, C5, SVTC) guide “Communication Command List”, made by Shinko Technos Corporation.

The following data item list is mentioned in the PC-900 Series communication guide for each channel. When the command type is 20H, data read can be performed. When it is 50H, data write can be performed.

(20H/50H are used to perform read and write.)

Command Classification	Data Item	Data
20H/50H	0001H : Fixed value control / Main setting value setting	Setting Value
20H/50H	0002H : Fixed value control / Control output (OUT 1) proportional band setting	Setting Value
20H/50H	0003H : Fixed value control / Integral time setting	Setting Value
20H/50H	0004H : Fixed value control / Derivative time setting	Setting Value
.	:	:

The item Nos. here are the GP addresses.

20H:Read command can be performed.
50H:Write command can be performed.

For data item “The setting of the main setting value (SV) for the stationary position control”, the item number is 0001H. As a result, the GP address is as follows.

0002

Address (Data Item)

For data item “The setting of the integrated time for the stationary position control”, the item number is 0003H. As a result, the GP address is “0003”.

For data item details, refer to the following Shinko Technos Corporation communication guides.

Series	Models	Guides
C	CPT-20A	Multi-Point Temperature Control Unit C Series Guide
FC	FCD-130	FC Series Communication (Option:C,C5) Guide
	FCD-150	
	FCR-130	
	FCR-150	
	FCS-200	
FIR	FIR-200	FIR Communication Guide
GC	GCS-300	GCS Communication Guide
FCL	FCL-100	FCL Communication Guide
PC-900	PC-935	PC-935, PC-955 Communication (Option:C,C5,SVTC) Guide
	PC-955	



- When the data item's setting value uses a decimal point items, the GP displays a value 10 times larger than the setting value. Also, when writing, be sure to write a value 10 times larger than the setting value.

E.g. In case of the PC-900 Series' control output (OUT1) proportional zone
 Indication of Controllers / Setting Value : 2.5%
 Indication of the GP : 25

Also, refer to each model's communication guide for details (with/without a decimal point) about data item setting value ranges.



- When setting Tags in the screen editor software, the Controller communication unit No. can be specified during address input. If a communication unit No. is not indicated, the previously entered communication unit No. is automatically used. (The default value is 1.)

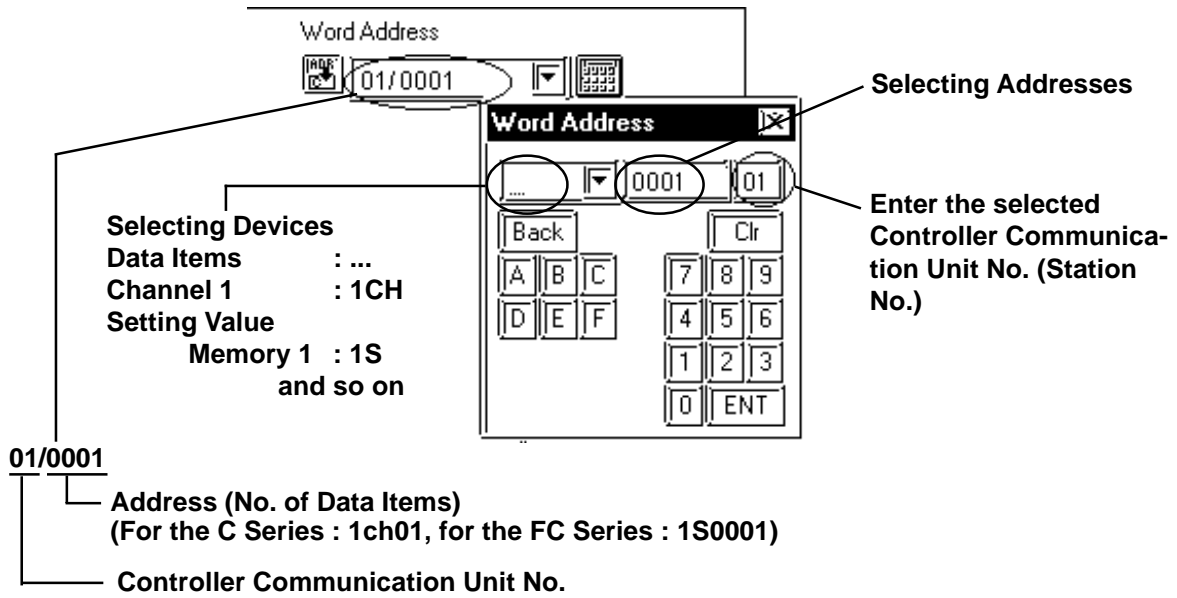

- **Do not use the system area because the GP/GLC's system area (LS0 to LS19) cannot be allocated to the Controller area. (Do not select all the system area.) The Controller's read area can be used as normal.**

12.6.4 Environment Setup

The following table lists the recommended Controller and GP/GLC communication settings.

■ C Series

GP/GLC Settings		Controller Settings	
Baud Rate	9600 bps	Baud Rate	9600 bps
Data Length	7 bits	-----	-----
Stop Bit	1 bit	-----	-----
Parity Bit	Even	-----	-----
Data Flow control	ER	-----	-----
Communication Format	4 Wires	-----	-----
Unit No.	1	Unit No. ^{*1}	1

**1 It is possible to set a Controller communication unit No. from 0 to 15, however, the GP/GLC can only be set from 1 to 15.*

■ FC/FIR/GC/FCL/PC-900 Series

GP/GLC Settings		Controller Settings	
Baud Rate	9600 bps	Baud Rate	9600 bps
Data Length	7 bits	-----	-----
Stop Bit	1 bit	-----	-----
Parity Bit	Even	-----	-----
Data Flow control	ER	-----	-----
Communication Format (using RS-232C)	RS-232C	Communication Format ^{*1}	Serial Communication
Communication Format (using RS-422)	2 wire type	Communication Format ^{*1}	Serial Communication
Unit No.	1	Unit No. ^{*2}	1

**1 PC-900 series only*

**2 It is possible to set a Controller communication unit No. from 0 to 95, however, the GP/GLC can only be set from 1 to 32.*

12.6.5 Error Code

Controller error codes are represented by the “Host communication error (02:**:##)”, and indicated in the left lower corner of the GP screen.

Error Codes	Meaning
01	Command does not exist
03	Exceeds setting value range
04	Unable to set (during AT execution)
05	Keyoperation has activated Setting Mode

For more details about the error codes, see

Reference *“The Controller Manual : Communication Guide for each series made by Shinko Technos Corporation”*





12.7 Fuji Electronic Corporation Controllers

12.7.1 System Structure

The following describes the system configuration used when connecting the GP/GLC to this Controller.

Micro-Controller X Series (Model:PXR)

Controller *1	Cable Diagram	GP/GLC
		
PXR4□□□□-□□M00 PXR4□□□□-□□V00	RS-422 <Cable diagram 1>	GP series GLC series
	RS-422 (1:n) <Cable diagram 2>	

*1 The Controller's model number "□□□□" will change, according to the options selected. For model number details, refer to the PXR4 Series catalog. When connecting the Controller to a GP, the RS-485 (MODBUS) option "M00" or "V00" is required.

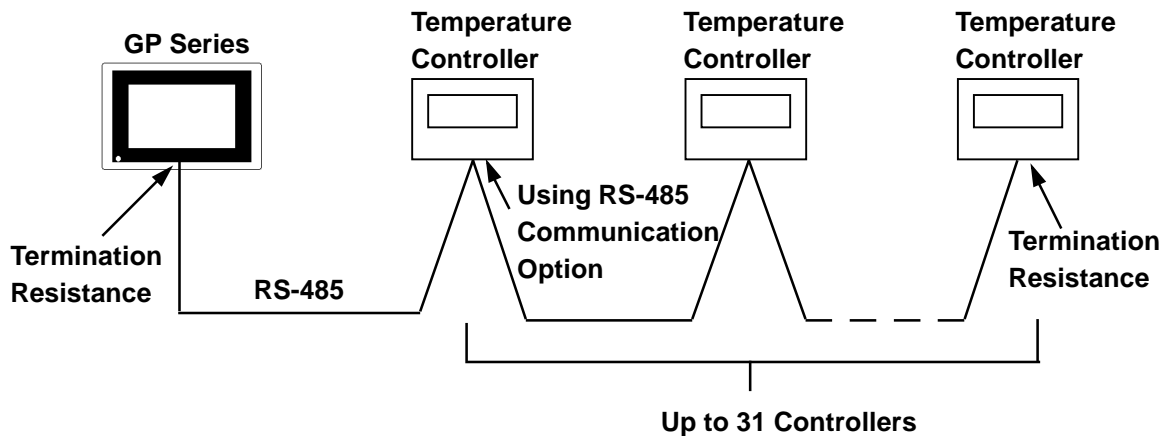

12.7.2 Cable Diagrams

The cable diagrams shown below and the cable diagrams recommended by Fuji Electric Co., Ltd. differ, however, using these cables for your Controller's operations will not cause any problems.



- **Ground your PLC's FG terminal according to your country's applicable standard.**
- **All RS-422 cables should be no more than 500 meters long.**

■ Cable Diagram 1 (1:1) RS-422(2-wire type)

- Using Digital's RS-422 connector terminal adapter GP070-CN10-0

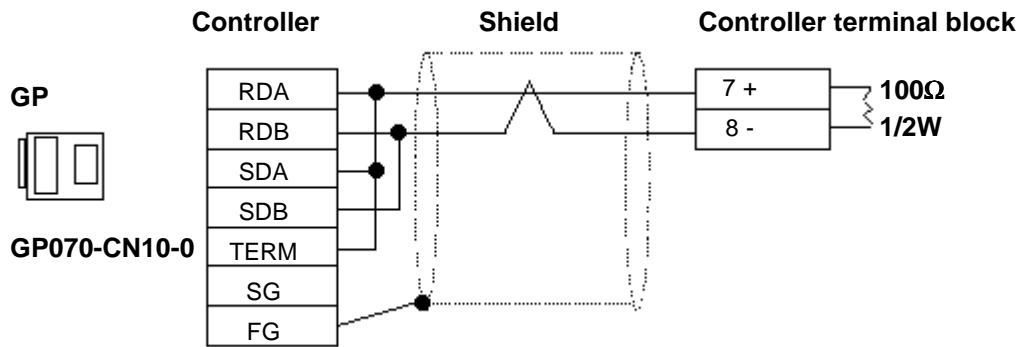

- Using Digital's RS-422 Cable GP230-IS11-0

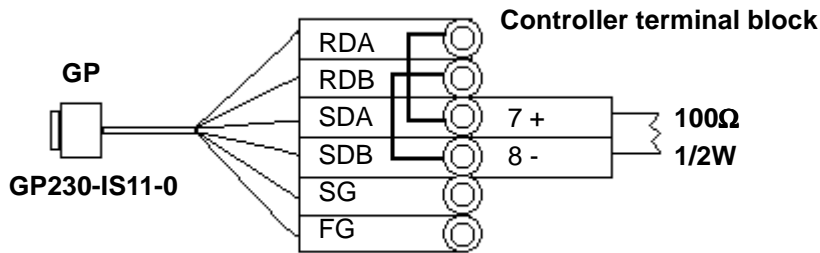

- **Be sure that RDA - SDA and RDB - SDB are both connected to the Controller terminal block.**



- **Since the SG and FG lines cannot be connected to the controller terminal block, be sure to cover them with insulating tape.**

- When making your own cables

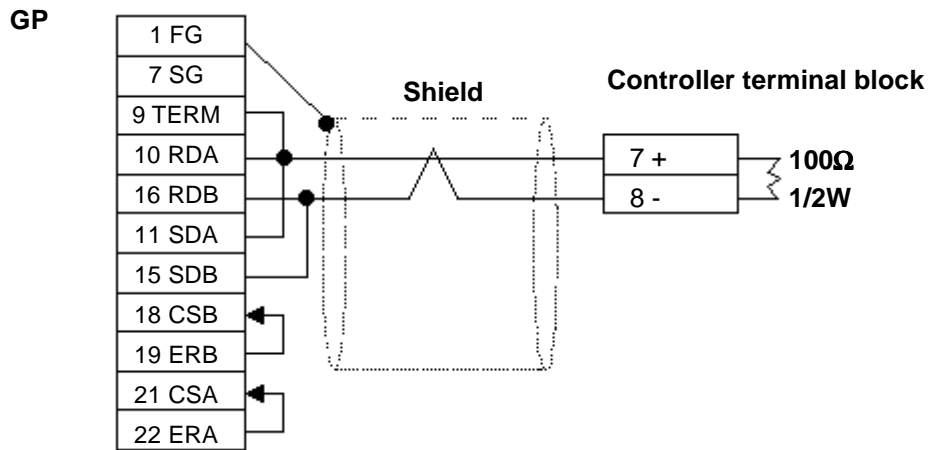

■ Cable Diagram 2 (1:n) RS-422 (2-wire type)

- Using Digital's RS-422 connector terminal adapter GP070-CN10-0

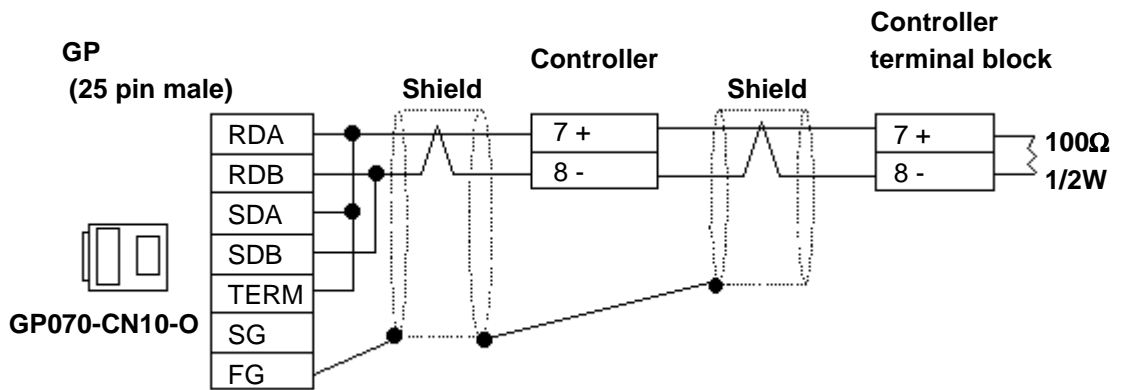

- Using Digital's RS-422 cable, GP230-IS11-0

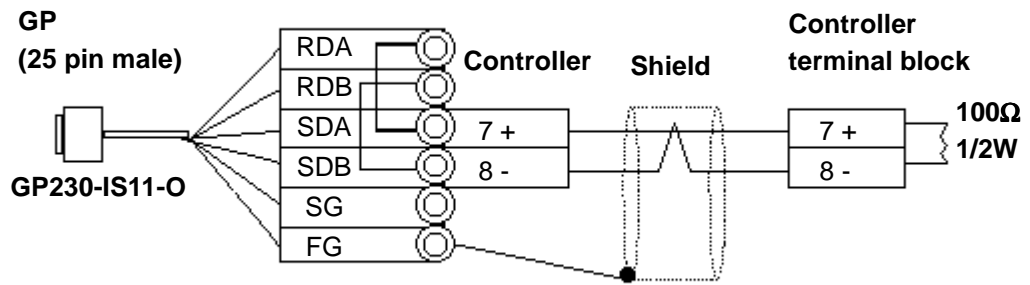

- Be sure that RDA - SDA and RDB - SDB are both connected to the Controller terminal block.



- Since the SG line cannot be connected to the controller terminal block, be sure to cover them with insulating tape.

- When making your own cable connections

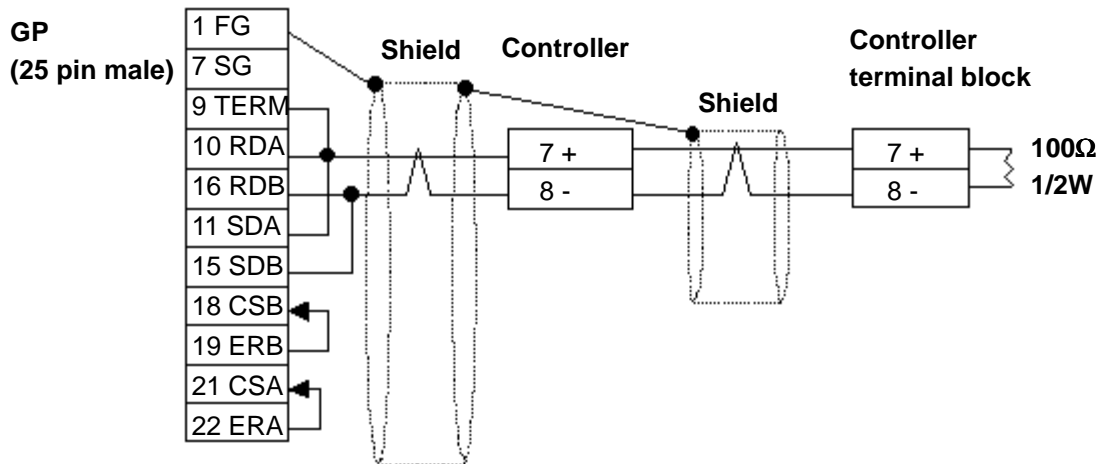

12.7.3 Supported Devices

The following list shows the range of devices supported by the GP/GLC.

■ Micro-Controller X Series (Model:PXR)

Device	Bit Address	Word Address	Comments	
Parameter	00001	—	^{*1}	H/L
	10001 ~ 10016	10001	^{*2}	
	3000100 ~ 3001515	30001 ~ 30015	Internal Calculation Value ^{*2}	
	4000100 ~ 4011315	40001 ~ 40113	Internal Calculation Value ^{*1}	
	3100100 ~ 3101515	31001 ~ 31015	Engineering Unit ^{*2}	
	4100100 ~ 4111315	41001 ~ 41113	Engineering Unit ^{*1}	

^{*1} Addresses 00001, 40001 and 41001 are used to store write commands (FIX Processing) in non-volatile memory. The non-volatile memory's write is performed via the writing of "Write Value 1". FIX processing lasts approximately 5 seconds. The Display Communication cannot be performed for 5 seconds if there are any Read-out Tags on the same screen.

Reference Instruction Manual for Fuji Electric Corporation's MICRO CONTROLLER X COMMUNICATION FUNCTION (RS-485 MODBUS), "FIX Processing"



- During the writing of data to non-volatile memory, do not turn off the Controller's power. If the Controller's power is cut, the data in non-volatile memory will be destroyed, thereby disabling the Controller.

^{*2} Data write is not possible.



- In the GP, the Controller's parameters are set via the Coil No. and Register No. For each Coil No. (00001~, 10001~) the last digit is recognized as the device. For Register No.s (30001~, 40001~, 31001~, 41001~) the last two digits are recognized as the device.
- For information about data item types and numbers, refer to the Instruction Manual for Fuji Electric Co., Ltd.'s MICRO CONTROLLER X COMMUNICATION FUNCTION (RS-485 MODBUS), "CHAPTER 7 ADDRESS MAP AND DATA FORMAT"
- The GP supports two types of Address Maps, the "Engineering Unit Address Map" and the "Internal Calculation Value Address Map".

The following data shows the memory maps for each parameter.

- When using Bit Data

Bit Data (Read Only) : Function [02H]

Relative Address	Coil No.	Type	Memory Contents	Read-out Data
0000H	10001	Bit	Alarm1 ON/OFF	0:Alarm1 OFF, 1:Alarm1 ON
0001H	10002		(Reserved)	
0002H	10003		(Reserved)	
0003H	10004		(Reserved)	
0004H	10005	Bit	Alarm2 ON/OFF	0:Alarm2 OFF, 1:Alarm2 ON
0005H	10006		(Reserved)	
:	:	:	:	:

The item Nos. here are the GP addresses.

Ex. For the parameter “Alarm1 ON/OFF” of Coil No. 10001, the GP’s designated address is as follows. Use the first digit of the Coil No. (00001~, 10001~) to designate the device.

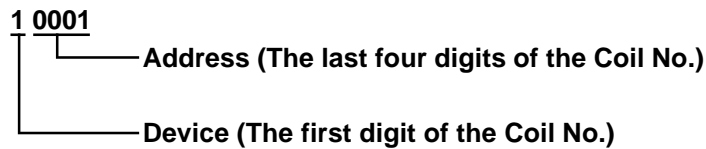

Ex. For the parameter “front surface control SV data” of Register No. 41003, the GP’s designated address is as follows. Use the first two digits of the Register No.s 30001~, 40001~, 31001~ and 41001~ to designate the device.

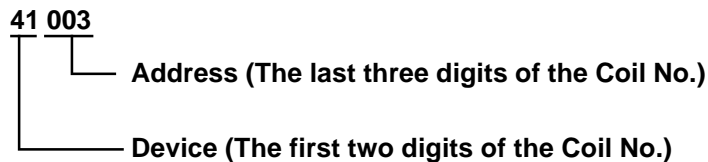

- **The Controller’s parameter data, when data transfer is performed, will have no decimal places. Thus, in the GP, processing must be performed to correct the data. For example, if a numeric display (N-tag) is used that includes decimal places, the “Data Type” and “No. of Decimals” settings must be used. Also, when writing data to a Controller, it is necessary to write decimal values as integers.**

Ex. Register No. 41025’s “Output 1 Lower Limit”

Controller Display/Setting Value : 3.00%

GP value/setting : 300

Reference

Also, refer to “Instruction Manual for Fuji Electric Co., Ltd.’s MICRO CONTROLLER X COMMUNICATION FUNCTIONS (RS-485 MODBUS)” for details (with/without a decimal point) about data item setting value ranges.



- When setting Parts or Tags in the screen editor software, the Controller communication unit No. can be specified during address input. If a communication unit No. is not indicated, the previously entered communication unit No. is automatically used. (The default value is 1)

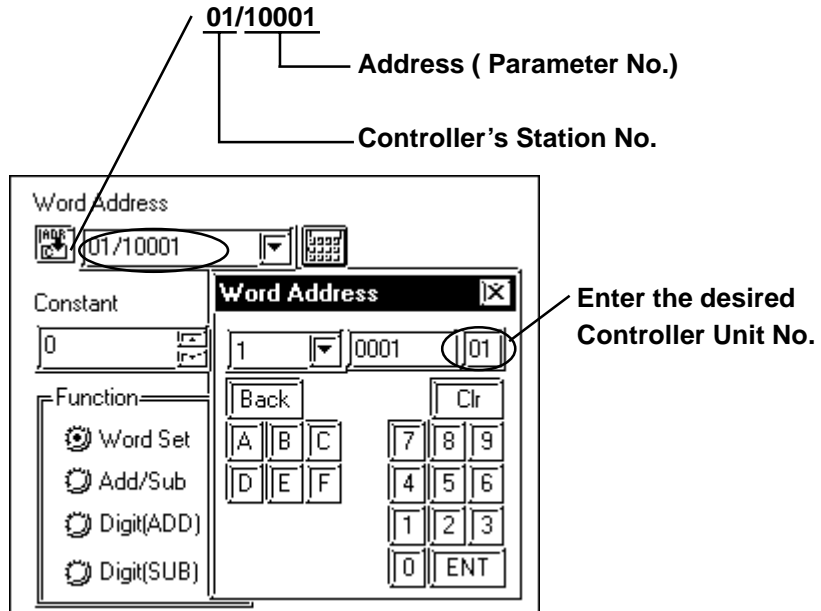

- **GP/GLC's System Area (LS0 to LS19) Settings**

The GP/GLC's system area (20 words) cannot be allocated to the Controller's own data area. Even though you can enter the system area settings via the GP's screen editor software or via the GP/GLC's OFFLINE screen, it is impossible to actually allocate the system area to the Controller's data area.

12.7.4 Environment Setup

The following table lists the recommended Controller and GP/GLC communication settings.

■ Micro-Controller X Series (Model:PXR)

GP/GLC Settings		Controller Settings	
Baud Rate	9600 bps (Fixed)	-----	-----
Data Length	8 bits (Fixed)	-----	-----
Stop Bit	1 bit (Fixed)	-----	-----
Parity Bit	Odd	Parity Settings (CoM)	0 : Odd
Data Flow control	ER	-----	-----
Communication Format (using RS-422)	2-wire type	-----	-----
Unit No. ^{*1}	1	Unit Station No. (Stno)	1

**1 It is possible to set a Controller communication unit No. from 0 to 255, however, the GP/GLC can only be set from 1 to 32. Zero cannot be used because it means "Communication function stop". The Read-in area can be used in the Controller that has set the Unit No. here.*

12.7.5 Error Code

Controller error codes are displayed by the “ Host Communication Error (02:**:##)”, and indicated in the left lower corner of the GP screen ** indicates the Controller’s error code, and ## indicates the number of the Controller unit. However, when the PLC is not correctly connected (02:FF), the unit number will not be shown.

Erro Code	Meaning
01	Illegal function
02	Illegal data address
03	Illegal data value

For more details about error codes, see

Reference *Instruction Manual for Fuji Electric Co., Ltd.’s MICRO CONTROLLER X COMMUNICATION FUNCTION (RS485 MODBUS)*



12.8 Toho Electronics Inc. Controllers



12.8.1 System Structure

The following describes the system configuration used when connecting the GP/GLC to this Controller.





- **After the Controller's power is turned ON, no communication is performed for about four seconds. As a result, note that it may take several seconds to start communication when the GP/GLC and the Controller are turned ON at the same time.**
- **When a save request command is sent to the Controller (STR write command), it can take up to six seconds for the controller to respond. At this time, note that the communication speed may slow significantly, which is indicated by the slowing of the update frequency of the GP/GLC display, as the GP or GLC enters the standby state.**

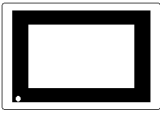

■ TTM-004/X04

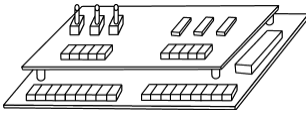
Temperature Controller	Cable Diagram	GP/GLC
		
TTM-004-□-A□□□ TTM-X04-□-□□□□	RS-422 (2-wire type) <Cable diagram 1>	GP or GLC series
	RS-422 (2-wire type, 1:n) <Cable diagram 3>	

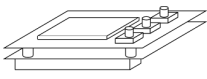

■ TTM-00B

Temperature Controller	Cable Diagram	GP/GLC
		
TTM-00B-□-□□□□	RS-422 (2-wire type) <Cable diagram 1>	GP or GLC series
	RS-422 (2-wire type, 1:n) <Cable diagram 3>	

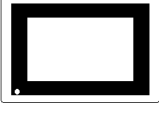

■ **TTM-10L**

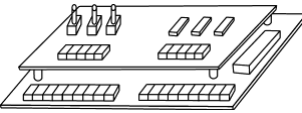
Temperature Controller	Cable Diagram	GP/GLC
		
TTM-10L-□-□-□	RS-422 (2-wire type) <Cable diagram 1>	GP or GLC Series
	RS-232C <Cable diagram 2>	
	RS-422 (2-wire type, 1:n) <Cable diagram 3>	

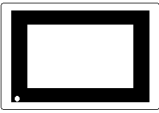

■ **TTM-100B**

Temperature Controller	Cable Diagram	GP/GLC
		
TTM-100B4-□ □-□ □ □ □-□ □ □ TTM-100B8-□ □-□ □ □ □ □-□ □ □	RS-422 (2-wire type) <Cable diagram 1>	GP or GLC Series
	RS-422 (2-wire type, 1:n) <Cable diagram 3>	

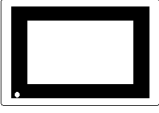

■ **TTM-110 Series**

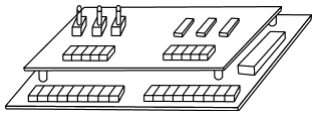
Temperature Controller	Cable Diagram	GP/GLC
		
TTM-114-□-□ □-□ □ □ □ □ □ □-□ TTM-115-□-□ □-□ □ □ □ □ □ □ □-□ TTM-117-□-□ □-□ □ □ □ □ □ □ □-□ TTM-119-□-□ □-□ □ □ □ □ □ □ □-□	RS-422 (2-wire type) <Cable diagram 1>	GP or GLC Series
	RS-422 (2-wire type, 1:n) <Cable diagram 3>	



■ TTM-110B Series

Temperature Controller	Cable Diagram	GP/GLC
		
TTM-110B-□-□ □-□□□□□□-□	RS-422 (2-wire type) <Cable diagram 1>	GP or GLC series
	RS-422 (2-wire type, 1:n) <Cable diagram 3>	

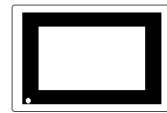

■ TTM-120 Series

Temperature Controller	Cable Diagram	GP/GLC
		
TTM-124-□-□ □-□□□□□□-□ TTM-125-□-□ □-□□□□□□-□ TTM-127-□-□ □-□□□□□□-□ TTM-129-□-□ □-□□□□□□-□	RS-422 (2-wire type) <Cable diagram 1>	GP or GLC series
	RS-422 (2-wire type, 1:n) <Cable diagram 3>	

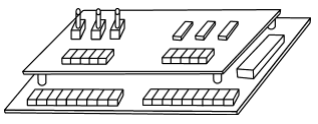

■ TTM-300 Series

Temperature Controller	Cable Diagram	GP/GLC
		
TTM-304-□-□N-□□□□-□ TTM-305-□-□N-□□□□-□ TTM-309-□-□N-□□□□-□	RS-422 (2-wire type) <Cable diagram 1>	GP or GLC series
	RS-422 (2-wire type, 1:n) <Cable diagram 3>	

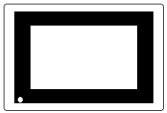
■ TTM-300B

Temperature Controller	Cable Diagram	GP/GLC
		
TTM-300B-□-□N-□□□□-□	RS-422 (2-wire type) <Cable diagram 1>	GP or GLC Series
	RS-422 (2-wire type, 1:n) <Cable diagram 3>	

■ TTM-1020 Series

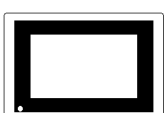
Temperature Controller	Cable Diagram	GP/GLC
		
TTM-1520-□ □-□ □-□□□-□ TTM-1521-□ □-□ □-□□□-□ TTM-1522-□ □-□ □-□□□-□ TTM-1523-□ □-□ □-□□□-□ TTM-1524-□ □-□ □-□□□-□ TTM-1525-□ □-□ □-□□□-□ TTM-1920-□ □-□ □-□□□-□ TTM-1921-□ □-□ □-□□□-□ TTM-1922-□ □-□ □-□□□-□ TTM-1923-□ □-□ □-□□□-□ TTM-1924-□ □-□ □-□□□-□ TTM-1925-□ □-□ □-□□□-□	RS-422 (2-wire type) <Cable diagram 1>	GP or GLC Series
	RS-422 (2-wire type, 1:n) <Cable diagram 3>	

12.8.2 Cable Diagrams

The cable diagrams shown below and the cable diagrams recommended by Toho Electronics Inc. may differ, however, using these cables for your Controller's operations will not cause any problems.



- **RS-422 connector terminal numbers will differ depending on the controller model. Prior to performing wiring, refer to your controller's User Manual.**
- **When using RS-232C format, all cables should be no more than 15 meters long and also using RS-422 format, all cables should be no more than 50 meters long.**

■ Cable Diagram 1 (1:1) RS-422 (2-wire type)

- **Using Digital's RS-422 connector terminal adapter GP070-CN10-0**

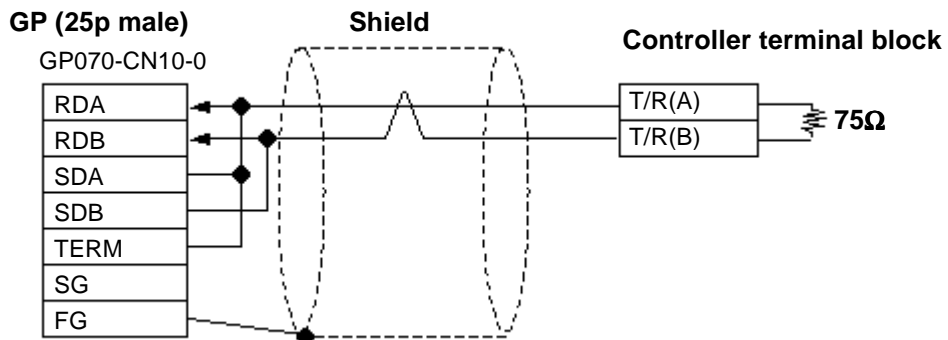

- **Using Digital's RS-422 Cable GP230-IS11-0**

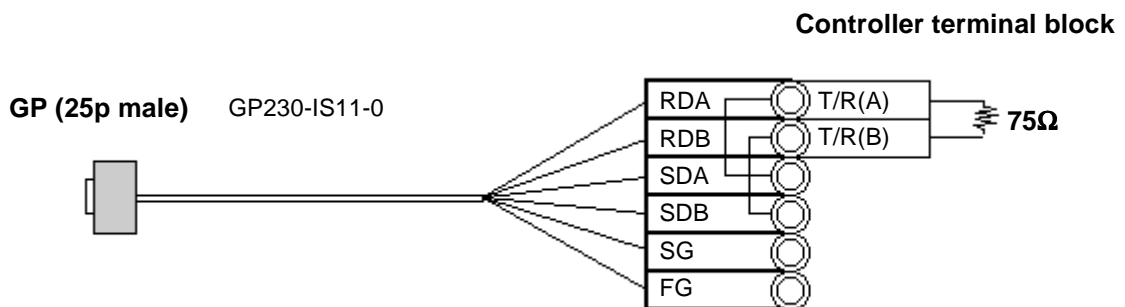

Note: Be sure that RDA - SDA and RDB - SDB are both connected to the Controller terminal block.



Since the SG and FG lines cannot be connected to the controller terminal block, be sure to cover them with insulating tape.

- When making your own cables

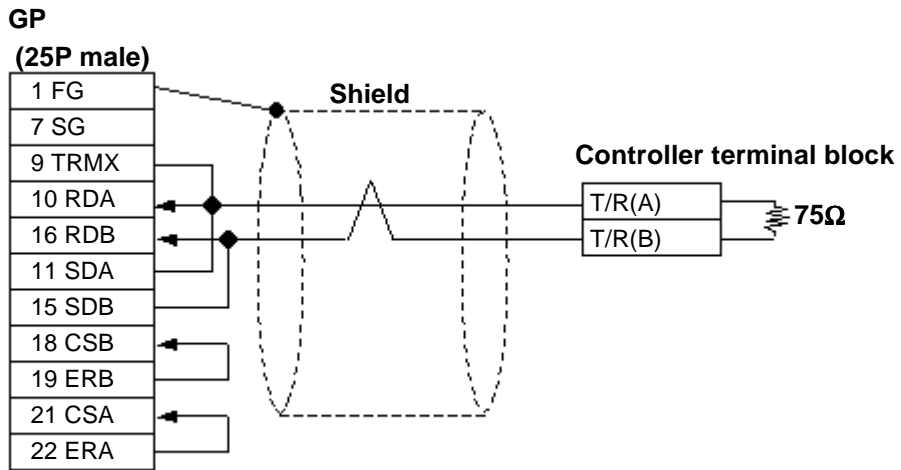

Note: When connecting the No.9 pin and No.10 pin in the GP Serial I/F, a termination resistance of 100Ω is added between RDA and RDB.

■ Cable Diagram 2 RS-232C

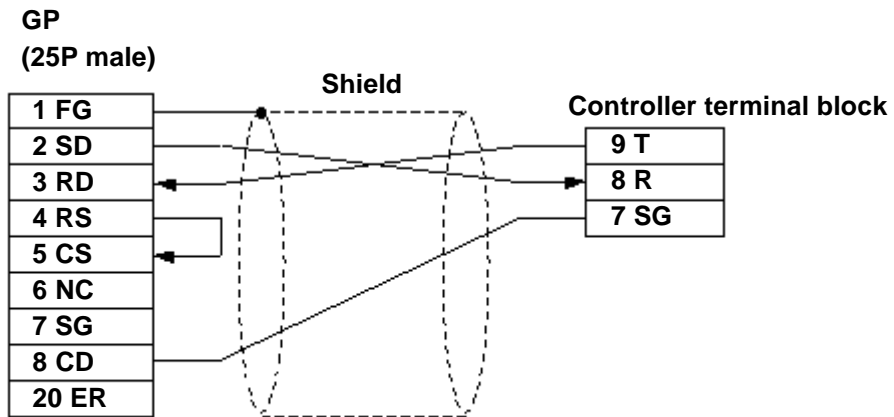

■ Cable Diagram 3 (1:n) RS-422



Ground a shielded cable in accordance with the electrical requirements of your system, using one of the following three methods.

- (1) Distributed grounding (as shown below)
- (2) Parallel grounding, or
- (3) Serial grounding.

• Using Digital's RS-422 connector terminal adapter GP070-CN10-0

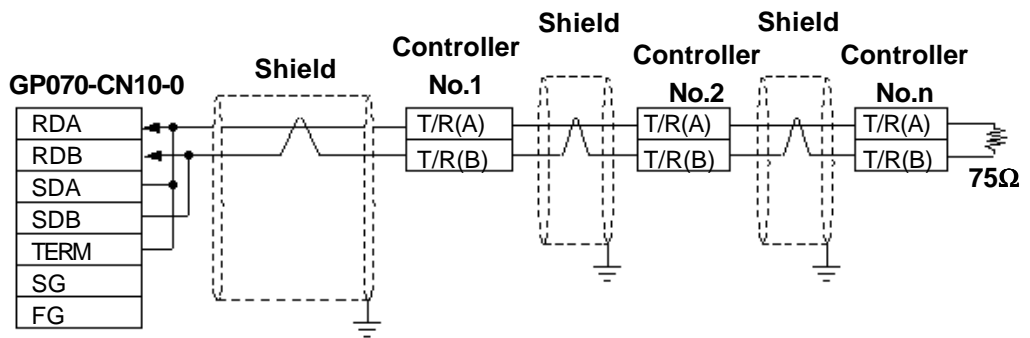

• Using Digital's RS-422 cable, GP230-IS11-0

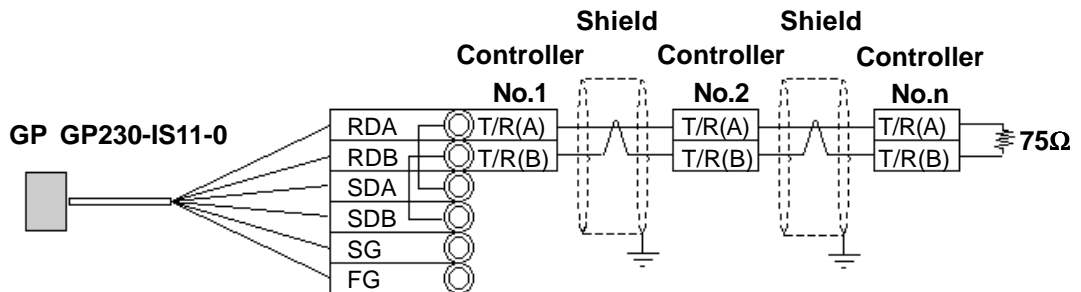

- Be sure that RDA - SDA and RDB - SDB are both connected to the Controller terminal block.



Since the SG and FG lines cannot be connected to the controller terminal block, be sure to cover them with insulating tape.

- When making your own cable connections

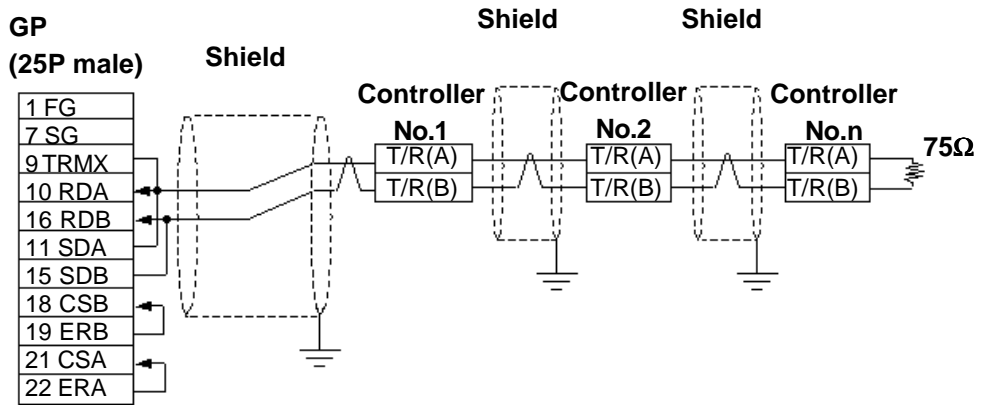

- When connecting the No.9 pin and No.10 pin in the GP Serial I/F, a termination resistance of 100Ω is added between RDA and RDB.

12.8.3 Supported Devices

The following list shows the range of devices supported by the GP/GLC.



Important

- **The Controller identifiers "1" and "2" (refer to your Controller's User Manual) are assigned to predefined addresses and devices. As a result, when you enter devices on the GP screen editor software, do so as shown below.**

Device Selection

(Select from 00_, 10_, 100_,
110_, 120_, 300_ or 1020_)

Address Selection

(Refer to Supported
Devices List on
following pages.)

Enter the Controller's
Communication Unit No.
(Station No.)

- **Each identifier has read and write limitations detailed information, refer to your Controller's Instruction Manual. For details about precautions when using identifier "2" with GP-PRO/PBIII, refer to TTM-300 Series Supported Device's *1 or *2.**
- **GP/GLC's System Area (LS0 to LS19) Settings**
The GP/GLC's system area (20 words) cannot be allocated to the Controller's own data area. Even though you can enter the system area settings via the GP's screen editor software or via the GP/GLC's OFFLINE screen, it is impossible to actually allocate the system area to the Controller's data area.
- **When you save data to your Controller's EEPROM (send a Save request), write it in the device address corresponding to symbol STR or identifier STR. For the TTM-300 series, this procedure is not needed since it saves data directly to the EEPROM.**
- **When saving data to the EEPROM, write the data to the device address that corresponds to your Controller's STR identifier.**



- **In the Read Area, only the devices "00_", "10_", "100_", "110_", "120_", "300_" and "1020_" can be set. All other devices, "SSV", "END", "STI", "SOK", "SWZ", "SWT", "SON", "SOF", "SRN" and "SEO" cannot be used.**
- **Depending on the Controller's setting conditions, the GP and GLC's pre-set setting values may be used. Refer to the table as shown below.**

Model	Address	Identifier	Controller Condition	Decimal marked values using onGP/GLC (Hex)
TTM-004/X04/00B (00_)	0	PV1	Over Scale	32767(0x7FFF)
			Under Scale	-32768(0x8000)
	2 ~ 10	PR1 ~ PR9	When an arbitrary identifier has been assigned to the priority screen. (When the display of PR1 to PR9 on the temperature controller is not OFF.)	0011 ~ 0077 *1
			In the case where no setting has been assigned to the priority screen. (When the display of PR1 to PR9 on the temperature controller is OFF.)	-32768(0x8000)
			In the case where the identifier COM has been assigned to the priority screen.	32767(0x7FFF) *2
			In the case where the identifier BPS has been assigned to the priority screen.	32766(0x7FFE) *2
			In the case where the identifier ADR has been assigned to the priority screen.	32765(0x7FFD) *2
			In the case where the identifier AWT has been assigned to the priority screen.	32764(0x7FFC) *2
In the case where the identifier MOD has been assigned to the priority screen.	32763(0x7FFB) *2			
TTM-10L (10_)	0	PV1	Over Scale	32767(0x7FFF)
			Under Scale	-32768(0x8000)
	23	□CJ	Over Scale	32767(0x7FFF)
			Under Scale	-32768(0x8000)
	24	PV2	Over Scale	32767(0x7FFF)
			Under Scale	-32768(0x8000)
TTM-100B (100_)	0	PV1	Over Scale	32767(0x7FFF)
TTM-110/110B (110_)	0	PV1	Over Scale	32767(0x7FFF)
			Under Scale	-32768(0x8000)
TTM-120 (120_)	0	PV1	Over Scale	32767(0x7FFF)
			Under Scale	-32768(0x8000)
TTM-300/300B (300_)	0	PV1	Over Scale	32767(0x7FFF)
			Under Scale	-32768(0x8000)
	4	□TI	When the Operation has finished	-32768(0x8000)

*1 Addresses allocated to each identifier

Reference 12.8.3 Supported Devices ■TTM-004/X04/00B

*2 This identifier cannot be registered as the priority screen function setting (PR1 to PR9) via a GP/GLC Write command. To register this function, use the front panel of the temperature controller.

- **You cannot use this device as a 32-bit device, since each identifier's addresses are not consecutive.**

■ TTM-004/X04/00B

Device	Bit Address	Word Address	Controller Setting item	Identifiers	Others
00_	000000 ~ 000015	0000	Process value PV	PV1	
	000100 ~ 000115	0001	Setting value SV	SV1	
	000200 ~ 000215	0002	Priority display set 1	PR1	
	000300 ~ 000315	0003	Priority display set 2	PR2	
	000400 ~ 000415	0004	Priority display set 3	PR3	
	000500 ~ 000515	0005	Priority display set 4	PR4	
	000600 ~ 000615	0006	Priority display set 5	PR5	
	000700 ~ 000715	0007	Priority display set 6	PR6	
	000800 ~ 000815	0008	Priority display set 7	PR7	
	000900 ~ 000915	0009	Priority display set 8	PR8	
	001000 ~ 001015	0010	Priority display set 9	PR9	
	001100 ~ 001115	0011	Set/select of input	INP	
	001200 ~ 001215	0012	Gain for PV correction	PVG	
	001300 ~ 001315	0013	Zero point for PV correction	PVS	
	001400 ~ 001415	0014	Filter input	PDF	
	001500 ~ 001515	0015	Decimal position	<input type="checkbox"/> DP	
	001600 ~ 001615	0016	Function by FUNC Key	<input type="checkbox"/> FU	
	001700 ~ 001715	0017	Lock	LOC	
	001800 ~ 001815	0018	SV H limit	SLH	
	001900 ~ 001915	0019	SV L limit	SLL	
	002000 ~ 002015	0020	Control mode	<input type="checkbox"/> MD	
	002100 ~ 002115	0021	Control type	CNT	
	002200 ~ 002215	0022	Set/select of normal or reverse	DIR	
	002300 ~ 002315	0023	Output1, manipulated value	MV1	
	002400 ~ 002415	0024	Tuning type	TUN	
	002500 ~ 002515	0025	AT coefficient	ATG	
	002600 ~ 002615	0026	AT sensitivity	ATC	
	002700 ~ 002715	0027	Output 1, proportional band	<input type="checkbox"/> P1	
	002800 ~ 002815	0028	Integral time	<input type="checkbox"/> I1	
	002900 ~ 002915	0029	Derivative time	<input type="checkbox"/> D1	
	003000 ~ 003015	0030	Output 1, proportional cycle	<input type="checkbox"/> T1	
	003100 ~ 003115	0031	Anti reset wind-up	ARW	
	003200 ~ 003215	0032	Setting of H limit for Output 2 MV limiter	MH1	
	003300 ~ 003315	0033	Setting of L limit for Output 2 MV limiter	ML1	
	003400 ~ 003415	0034	Output 1, control sensitivity	<input type="checkbox"/> C1	
	003500 ~ 003515	0035	Output 1, OFF position	CP1	
	003600 ~ 003615	0036	Output 2, manipulated value	MV2	
	003700 ~ 003715	0037	Output 2, proportional band	<input type="checkbox"/> P2	
	003800 ~ 003815	0038	Output 2, proportional cycle	<input type="checkbox"/> T2	
	003900 ~ 003915	0039	Setting of H limit for Output 2 MV limiter	MH2	
	004000 ~ 004015	0040	Setting of L limit for Output 2 MV limiter	ML2	
	004100 ~ 004115	0041	Manual reset	PBB	
	004200 ~ 004215	0042	Output 2, control sensitivity	<input type="checkbox"/> C2	
	004300 ~ 004315	0043	Output 2, OFF position	CP2	
	004400 ~ 004415	0044	Dead band	<input type="checkbox"/> DB	
	004500 ~ 004515	0045	EV 1, function	E1F	
	004600 ~ 004615	0046	EV 1, H limit	E1H	
	004700 ~ 004715	0047	EV 1, L limit	E1L	
	004800 ~ 004815	0048	EV 1, sensitivity	E1C	
004900 ~ 004915	0049	EV 1, delay timer	E1T		

Device	Bit Address	Word Address	Controller Setting item	Identifier	other
00_	005000 ~ 005015	0050	Abnormal SV/heater function	E1B	
	005100 ~ 005115	0051	EV 1, polarity	E1P	
	005200 ~ 005215	0052	CT input	CM1	
	005300 ~ 005315	0053	EV 1, abnormal current of heater	CT1	
	005400 ~ 005415	0054	EV 2, function	E2F	
	005500 ~ 005515	0055	EV 2, H limit	E2H	
	005600 ~ 005615	0056	EV 2, L limit	E2L	
	005700 ~ 005715	0057	EV 2, sensitivity	E2C	
	005800 ~ 005815	0058	EV 2, delay timer	E2T	
	005900 ~ 005915	0059	EV 2, abnormal SV/ heater function	E2B	
	006000 ~ 006015	0060	EV 2, polarity	E2P	
	006100 ~ 006115	0061	CT input	CM2	
	006200 ~ 006215	0062	EV 2, abnormal current of heater	CT2	
	006300 ~ 006315	0063	DI input	DIF	
	006400 ~ 006415	0064	Polarity of DI	DIP	
	006500 ~ 006515	0065	Control setting 2	SV2	
	006600 ~ 006615	0066	Timer output	TMO	
	006700 ~ 006715	0067	Timer function	TMF	
	006800 ~ 006815	0068	Timer unit switch	H/M	
	006900 ~ 006915	0069	Allowable width for timer SV start	TSV	
	007000 ~ 007015	0070	Time setting	TIM	
	007100 ~ 007115	0071	Monitor of remaining time	TIA	
	_____	0072	Timer start/stop	TST	<input type="checkbox"/>
	007300 ~ 007315	0073	Output monitor	OM1	
	007400 ~ 007415	0074	AT start/stop	<input type="checkbox"/> AT	
	_____	0075	Data store	STR	<input type="checkbox"/>

■ TTM-10L

Device	Bit Address	Word Address	Control Setting Item	Identifier	Other
10_	000000 ~ 000015	0000	Process Variable (PV)	PV1	
	000100 ~ 000115	0001	Control Setting Value (SV)	<input type="checkbox"/> SV	
	000200 ~ 000215	0002	EV L. Limit Set	1L1	
	000300 ~ 000315	0003	EV H. Limit Set	1H1	
	000400 ~ 000415	0004	Auto-Tuning Start/Release	<input type="checkbox"/> AT	
	000500 ~ 000515	0005	Proportional Band	<input type="checkbox"/> P1	
	000600 ~ 000615	0006	Integral Time	<input type="checkbox"/> I1	
	000700 ~ 000715	0007	Derivative Time	<input type="checkbox"/> D1	
	000800 ~ 000815	0008	P-cycle Time	<input type="checkbox"/> T1	
	000900 ~ 000915	0009	Control Sensitivity	<input type="checkbox"/> C1	
	001000 ~ 001015	0010	Set/Select of Input/Output	<input type="checkbox"/> IO	
	001100 ~ 001115	0011	L. Limit of SV Limiter	SLL	
	001200 ~ 001215	0012	H. Limit of SV Limiter	SLH	
	001300 ~ 001315	0013	Control Type	CNT	
	001400 ~ 001415	0014	PV Correction	PVS	
	001500 ~ 001515	0015	Manual Reset	PBB	
	001600 ~ 001615	0016	OFF Position	<input type="checkbox"/> CP	
	001700 ~ 001715	0017	EV Function	A1F	
	001800 ~ 001815	0018	EV Sensitivity	ALC	
	001900 ~ 001915	0019	Decimal Point Position	<input type="checkbox"/> DP	
	002000 ~ 002015	0020	Selection of C/F	<input type="checkbox"/> CF	
	002100 ~ 002115	0021	Setting of Lock Function	LOC	
	002200 ~ 002215	0022	Temperature of cooling contact compensation	<input type="checkbox"/> CJ	
	002300 ~ 002315	0023	Process Variable (PV) with decimal point	PV2	
	002400 ~ 002415	0024	Output state monitor	OM1	
—————	0025	Data store	STR	<input type="checkbox"/>	

■ TTM-110Series (TTM-114, 115, 117, 119)/110B

Device	Bit Address	Word Address	Controll Setting Item	PV	Other
10_	000000 ~ 000015	0000	Process value (PV)	PV1	
	000100 ~ 000115	0001	Control set value (SV)	<input type="checkbox"/> SV	
	000200 ~ 000215	0002	Main control MV (OUT1)	MV1	
	000300 ~ 000315	0003	Main control MV (OUT2)	MV2	
	000400 ~ 000415	0004	Auto-tuning start/release	<input type="checkbox"/> AT	
	000500 ~ 000515	0005	Alarm 1 L limit set	1L1	
	000600 ~ 000615	0006	Alarm 1 H limit set	1H1	
	000700 ~ 000715	0007	Main control P-band	<input type="checkbox"/> P1	
	000800 ~ 000815	0008	Integral time	<input type="checkbox"/> I1	
	000900 ~ 000915	0009	Derivative time	<input type="checkbox"/> D1	
	001000 ~ 001015	0010	Output 1 P-cycle time	<input type="checkbox"/> T1	
	001100 ~ 001115	0011	Output 1 sensitivity	<input type="checkbox"/> C1	
	001200 ~ 001215	0012	Output 2 P-band	PC1	
	001300 ~ 001315	0013	Output 2 P-cycle time	TC1	
	001400 ~ 001415	0014	Output 2 sensitivity	CC1	
	001500 ~ 001515	0015	Dead Band	DB1	
	001600 ~ 001615	0016	Cooling Point of Contact Compensation	<input type="checkbox"/> CJ	
	001700 ~ 001715	0017	Set/Select of Input/Output	<input type="checkbox"/> IO	
	001800 ~ 001815	0018	Setting of L limit for OUT1 MV Limiter	MLL	
	001900 ~ 001915	0019	Setting of H limit for OUT1 MV Limiter	MLH	
	002000 ~ 002015	0020	Setting of L limit of SV Limiter	SLL	
	002100 ~ 002115	0021	Setting of H limit of SV Limiter	SLH	
	002200 ~ 002215	0022	Control action select	CNT	
	002300 ~ 002315	0023	Setting of sensor value correction	PVS	
	002400 ~ 002415	0024	Manual reset value	PBB	
	002500 ~ 002515	0025	Alarm 1 function	A1F	
	002600 ~ 002615	0026	AL output sensitivity	ALC	
	002700 ~ 002715	0027	Heater abnormal current	<input type="checkbox"/> CT	
	002800 ~ 002815	0028	Selection of data transmission function	TR1	
	002900 ~ 002915	0029	Selection of C/F	<input type="checkbox"/> CF	
	003000 ~ 003015	0030	Output state monitor	OM1	
	003100 ~ 003115	0031	Response Delay Speed	AWT	
_____	0032	Data store	STR	<input type="checkbox"/> S1	

■TTM-110Series(TTM-114, 115, 117, 119)/110B

Device	Bit Address	Word Address	Controller Setting Item	Identifier	Other
110_	000000 ~ 000015	0000	Process Value (PV)	PV1	
	000100 ~ 000115	0001	Control Set Value (SV)	<input type="checkbox"/> SV	
	000200 ~ 000215	0002	Main Control MV (OUT 1)	MV1	
	000300 ~ 000315	0003	Sub-Control MV (OUT 2)	MV2	
	000400 ~ 000415	0004	Timer Remainder Time	TIA	
	000500 ~ 000515	0005	Auto-Tuning Start/Release	<input type="checkbox"/> AT	
	000600 ~ 000615	0006	Time Setting On Timer	TIM	
	000700 ~ 000715	0007	Alarm 1 L. Limit Set	1L1	
	000800 ~ 000815	0008	Alarm 1 H. Limit Set	1H1	
	000900 ~ 000915	0009	Alarm 2 L. Limit Set	2L1	
	001000 ~ 001015	0010	Alarm 2 H. Limit Set	2H1	
	001100 ~ 001115	0011	Main Control P-band	<input type="checkbox"/> P1	
	001200 ~ 001215	0012	Integral Time	<input type="checkbox"/> I1	
	001300 ~ 001315	0013	Derivative Time	<input type="checkbox"/> D1	
	001400 ~ 001415	0014	Output 1 P-cycle Time	<input type="checkbox"/> T1	
	001500 ~ 001515	0015	Output 1 Sensitivity	<input type="checkbox"/> C1	
	001600 ~ 001615	0016	Output 2 P-band	PC1	
	001700 ~ 001715	0017	Output 2 P-cycle Time	TC1	
	001800 ~ 001815	0018	Output 2 Sensitivity	CC1	
	001900 ~ 001915	0019	Dead Band	DB1	
	002000 ~ 002015	0020	Set/Select of Input/Output Type	<input type="checkbox"/> IO	
	002100 ~ 002115	0021	Setting of L. Limit For Out 1 MV Limiter	MLL	
	002200 ~ 002215	0022	Setting of H. Limit For Out 1 MV Limiter	MLH	
	002300 ~ 002315	0023	Setting of H. Limit of SV Limiter	SLL	
	002400 ~ 002415	0024	Setting of L. Limit of SV Limiter	SLH	
	002500 ~ 002515	0025	Control Action Select	CNT	
	002600 ~ 002615	0026	Setting of Sensor Value Correction	PVS	
	002700 ~ 002715	0027	Manual Reset Value	PBB	
	002800 ~ 002815	0028	Timer Operation Mode	TMM	
	002900 ~ 002915	0029	Alarm 1 Function	A1F	
	003000 ~ 003015	0030	Alarm 2 Function	A2F	
	003100 ~ 003115	0031	AL Output Sensitivity	ALC	
	003200 ~ 003215	0032	Heater Abnormal Current	<input type="checkbox"/> CT	
	003300 ~ 003315	0033	Selection of Data Transmission Function	TR1	
	003400 ~ 003415	0034	Decimal Point Position	<input type="checkbox"/> DP	
	003500 ~ 003515	0035	Selection of C/F	<input type="checkbox"/> CF	
	003600 ~ 003615	0036	Buzzer Sound Setting	<input type="checkbox"/> BU	
	003700 ~ 003715	0037	Setting of Lock Function	LOC	
	003800 ~ 003815	0038	Output State Monitor	OM1	
	—————	0039	Timer Reset	TMS	<input type="checkbox"/> 1.5
	004000 ~ 004015	0040	Run/Ready Status	RUN	
—————	0041	Data Store	STR	<input type="checkbox"/> 1.5	

■TTM-120 Series (TTM-124, 125, 127, 129)

Device	Bit Address	Word Address	Controller Setting Item	Identifier	Other
120_	000000 ~ 000015	0000	Process Value (PV)	PV1	
	000100 ~ 000115	0001	Control Set Value (SV)	<input type="checkbox"/> AV	
	000200 ~ 000215	0002	Control Mode	MD1	
	000300 ~ 000315	0003	Main Control MV (OUT1)	MV1	
	000400 ~ 000415	0004	Sub-Control MV (OUT2)	MV2	
	000500 ~ 000515	0005	Auto-Tuning Start/Release	<input type="checkbox"/> AT	
	000600 ~ 000615	0006	Alarm 1L Limit Set	1L1	
	000700 ~ 000715	0007	Alarm 1H Limit Set	1H1	
	000800 ~ 000815	0008	Alarm 2L Limit Set	2L1	
	000900 ~ 000915	0009	Alarm 2H Limit Set	2H1	
	001000 ~ 001015	0010	Output 1 P-band	<input type="checkbox"/> P1	
	001100 ~ 001115	0011	Integral Time	<input type="checkbox"/> I1	
	001200 ~ 001215	0012	Derivative Time	<input type="checkbox"/> D1	
	001300 ~ 001315	0013	Output 1 P-cycle Time	<input type="checkbox"/> T1	
	001400 ~ 001415	0014	Output 1 Sensivity	<input type="checkbox"/> C1	
	001500 ~ 001515	0015	Main Control OFF Position	<input type="checkbox"/> CP	
	001600 ~ 001615	0016	Output 2 P-band	PC1	
	001700 ~ 001715	0017	Output 2 P-cycle Time	TC1	
	001800 ~ 001815	0018	Output 2 Sensivity	CC1	
	001900 ~ 001915	0019	Output 2 OFF Position	CCP	
	002000 ~ 002015	0020	Dead Band	DB1	
	002100 ~ 002115	0021	Set/Select of Input/Output Type	<input type="checkbox"/> IO	
	002200 ~ 002215	0022	Setting of L. Limit for Out1 MV Limiter	MLL	
	002300 ~ 002315	0023	Setting of H. Limit for Out1 MV Limiter	MLH	
	002400 ~ 002415	0024	Setting of L. Limit of SV Limiter	SLL	
	002500 ~ 002515	0025	Setting of H. Limit of SV Limiter	SLH	
	002600 ~ 002615	0026	Control Action Select	CNT	
	002700 ~ 002715	0027	Rump Time of SV1	RP1	
	002800 ~ 002815	0028	Setting of Sensor Value correction	PVS	
	002900 ~ 002915	0029	Digital PV Filter	PDF	
	003000 ~ 003015	0030	Manual Reset Value	PBB	
	003100 ~ 003115	0031	Swiching for Balanceless Bumpless	<input type="checkbox"/> BB	
	003200 ~ 003215	0032	Alarm 1 Function	A1F	
	003300 ~ 003315	0033	Alarm 2 Function	A2F	
	003400 ~ 003415	0034	AL Output Sensivity	ALC	
	003500 ~ 003515	0035	Heater Abnormal Current	<input type="checkbox"/> CT	
	003600 ~ 003615	0036	Selection of Data Transmission Function	TR1	
	003700 ~ 003715	0037	DI Function	<input type="checkbox"/> DI	
	003800 ~ 003815	0038	Decimal Point Position	<input type="checkbox"/> DP	
	003900 ~ 003915	0039	Selection of C/F	<input type="checkbox"/> CF	
	004000 ~ 004015	0040	Buzzer Sound Setting	<input type="checkbox"/> BU	
	004100 ~ 004115	0041	Setting of Lock	LOC	
	004200 ~ 004215	0042	Output State Monitor	OM1	
—————	0043	Data Store	STR		

■TTM-300 Series (TTM-304, 305, 309)/300B

Device	Bit Address	Word Address	Controller Setting Item	Identifier	Other
300_	000000 ~ 000015	0000	Process Value (PV)	PV1	
	000100 ~ 000115	0001	Mode change	<input type="checkbox"/> MD	
	000200 ~ 000215	0002	Control Setting Value (SV)	<input type="checkbox"/> SV	
	000300 ~ 000315	0003	Run Step Setting Value (SV)	OSV	
	000400 ~ 000415	0004	The time elapsed	<input type="checkbox"/> TI	
	000500 ~ 000515	0005	Run step setting time	OTI	
	000600 ~ 000615	0006	Count numbers of time executed	SRR	
	—————	0007	Step forward function execution	ADV	<input type="checkbox"/> [Bit 5]
	000800 ~ 000815	0008	Pattern number	<input type="checkbox"/> PT	
000900 ~ 000915	0009	Step number	<input type="checkbox"/> ST		
SSV	000000 ~ 204715	0000 ~ 2047 ^{*1}	Step temperature setting	SSV	
END	000000 ~ 204715	0000 ~ 2047 ^{*1}	Final step setting	END	
STI	000000 ~ 204715	0000 ~ 2047 ^{*1}	Step time setting	STI	
SOK	000000 ~ 204715	0000 ~ 2047 ^{*1}	Final step finish condition setting	SOK	
SWZ	000000 ~ 204715	0000 ~ 2047 ^{*1}	Step wait zone	SWZ	
SWT	000000 ~ 204715	0000 ~ 2047 ^{*1}	Step wait time	SWT	
SON	000000 ~ 204715	0000 ~ 2047 ^{*1}	Time signal ON time	SON	
SOF	000000 ~ 204715	0000 ~ 2047 ^{*1}	Time signal OFF time	SOF	
SRN	000000 ~ 200015	0000 ~ 2000 ^{*2}	Execution time	SRN	
SEO	000000 ~ 200015	0000 ~ 2000 ^{*2}	End signal ON time	SEO	
300_	001000 ~ 001015	0010	Pattern numbers	PAT	
	001100 ~ 001115	0011	Step numbers	STP	
	001200 ~ 001215	0012	PV correction	PVS	
	001300 ~ 001315	0013	Change C/ F	<input type="checkbox"/> CF	
	001400 ~ 001415	0014	Type of Control	CNT	
	001500 ~ 001515	0015	Type of Input/Output	<input type="checkbox"/> IO	
	001600 ~ 001615	0016	Select decimal position	<input type="checkbox"/> DP	
	001700 ~ 001715	0017	Mainipulated value limiter Low	MLL	
	001800 ~ 001815	0018	Manipulated value limiter High	MLH	
	001900 ~ 001915	0019	Setting of L. limit of SV limiter	SLL	
	002000 ~ 002015	0020	Setting of H. limit of SV limiter	SLH	
	002100 ~ 002115	0021	Select PV start or SV start	PSV	
	002200 ~ 002215	0022	SV start setting value	SVS	
	002300 ~ 002315	0023	Select Start at Power ON	PON	
	002400 ~ 002415	0024	Event Output 1 function	DO1	
	002500 ~ 002515	0025	PV Event Output 1 function	A1F	
	002600 ~ 002615	0026	Event Output 1 Low limit	A1L	
	002700 ~ 002715	0027	Event Output 1 High limit	A1H	
	002800 ~ 002815	0028	Event Output 1 sensitivity	A1C	
	002900 ~ 002915	0029	Time signal 1 Output mode	TF1	
	003000 ~ 003015	0030	Time signal 1 ON time	ON1	
003100 ~ 003115	0031	Time signal 1 OFF time	OF1		
003200 ~ 003215	0032	Event output 1 unusual looping time	LT1		
003300 ~ 003315	0033	Event Output 2 function	DO2		
003400 ~ 003415	0034	PV Event Output 2 function	A2F		
003500 ~ 003515	0035	Event Output 2 Low limit	A2L		

Device	Bit Address	Word Address	Controller Setting Item	Identifier	Other
300-	003600 ~ 003615	0036	Event Output 2 High limit	A2H	
	003700 ~ 003715	0037	Event Output 2 sensitivity	A2C	
	003800 ~ 003815	0038	Time signal 2 Output mode	TF2	
	003900 ~ 003915	0039	Time signal 2 ON time	ON2	
	004000 ~ 004015	0040	Time signal 2 OFF time	OF2	
	004100 ~ 004115	0041	Event output 2 unusual looping time	LT2	
	004200 ~ 004215	0042	Key lock function	LOC	
	004300 ~ 004315	0043	Output condition monitor	OM1	
	004400 ~ 004415	0044	[Low temperature] Proportional	<input type="checkbox"/> P1	
	004500 ~ 004515	0045	[Low temperature] Integrated time	<input type="checkbox"/> I1	
	004600 ~ 004615	0046	[Low temperature] Differential time	<input type="checkbox"/> D1	
	004700 ~ 004715	0047	Middle point 1 setting	PM1	
	004800 ~ 004815	0048	[Middle temperature] Proportional	<input type="checkbox"/> P2	
	004900 ~ 004915	0049	[Middle temperature] Integrated	<input type="checkbox"/> I2	
	005000 ~ 005015	0050	[Middle temperature] Differential	<input type="checkbox"/> D2	
	005100 ~ 005115	0051	Middle point 2 setting	PM2	
	005200 ~ 005215	0052	[High temperature] Proportional	<input type="checkbox"/> P3	
	005300 ~ 005315	0053	[High temperature] Integrated time	<input type="checkbox"/> I3	
	005400 ~ 005415	0054	[High temperature] Differential time	<input type="checkbox"/> D3	
	005500 ~ 005515	0055	Proportional Cycle	<input type="checkbox"/> <input type="checkbox"/> T	
	005600 ~ 005615	0056	Fuzzy constant	FUZ	
	005700 ~ 005715	0057	Control sensitivity to [Low temperature]	<input type="checkbox"/> C1	
	005800 ~ 005815	0058	Control sensitivity to [Middle temperature]	<input type="checkbox"/> C2	
	005900 ~ 005915	0059	Control sensitivity to [High temperature]	<input type="checkbox"/> C3	
	006000 ~ 006015	0060	Auto-tuning setting value of [High temperature]	AT1	
	006100 ~ 006115	0061	Auto-tuning setting value of [Middle temperature]	AT2	
	006200 ~ 006215	0062	Auto-tuning setting value of [High temperature]	AT3	
	_____	0063	Auto-tuning execution of [Low temperature]	AP1	<input type="checkbox"/>
_____	0064	Auto-tuning execution of [Middle temperature]	AP2	<input type="checkbox"/>	
_____	0065	Auto-tuning execution of [High temperature]	AP3	<input type="checkbox"/>	
_____	0066	Auto-tuning execution of [Low]->[Middle]->[High] temperature	AP4	<input type="checkbox"/>	
006700 ~ 006715	0067	Auto-tuning under execution	ATR		

*1 When using identifiers from SSV to SOF with a TTM-300 series unit, use the Device Name as the identifier, and the Step No. and Pattern No. as the address. The maximum values available for the pattern number and the step number that can be set on a GP/GLC are 20 and 47, respectively. Specify them as shown below.

Ex.)

Device	Bit Address	Word Address	Control Setting Item	Identifier
SSV	000000 ~ 204715	0000 ~ 2047	Step Temperature Setting	SSV

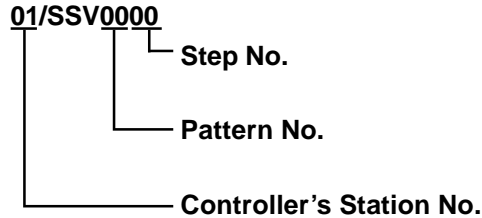

*2 When using identifier SRN or SEO with the TTM-300 series unit, use the Device Name as the identifier, and the Step No. and Pattern No. as the address. The maximum values available for the pattern number and the step number that can be set on a GP/GLC is 20, respectively. Specify them as shown below.

Ex.)

Device	Bit Address	Word Address	Controller Setting Item	Identifier
SRN	000000 ~ 200015	0000 ~ 2000	Excution Time	SRN

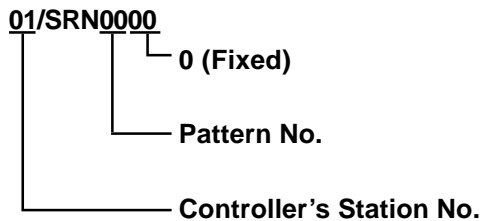

When entering addresses for identifiers SSV to SEO with a TTM-300 series unit, be sure to refer *1 or *2 above.

Device Selection

(Select from SSV, END, STI, SOK, SWZ, SWT, SON, SOF, SRN or SEO)

Address Selection
(Step No. or Pattern No.)

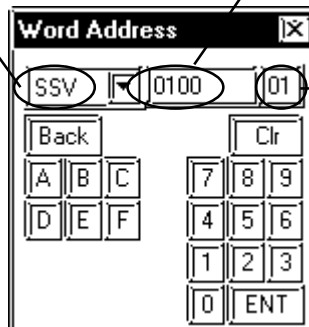

Enter the Controller's Station No.

■ TTM-1020 Series(TTM-1520, 1521, 1522, 1523, 1524, 1525, 1920, 1921, 1922, 1923, 1924, 1925)

Device	Bit Address	Word Address	Controller Setting Item	Identifier	Other
1020_	000000 - 000015	0000	Process Value (PV)	PV1	
	000100 - 000115	0001	CH No.	<input type="checkbox"/> CH	
	000200 - 000215	0002	Control Setting Value (SV)	<input type="checkbox"/> SV	
	000300 - 000315	0003	SV1	SV1	
	000400 - 000415	0004	Set/Select of Auto/Manual	MD1	
	000500 - 000515	0005	Set/Select of Remote/Local	REM	
	000600 - 000615	0006	Main Control MV (Out 1)	MV1	
	000700 - 000715	0007	Main Control MV (Out 2)	MV2	
	000800 - 000815	0008	Auto-Tuning Start/Release	<input type="checkbox"/> AT	
	000900 - 000915	0009	SV2	SV2	
	001000 - 001015	0010	SV3	SV3	
	001100 - 001115	0011	SV4	SV4	
	001200 - 001215	0012	SV5	SV5	
	001300 - 001315	0013	SV6	SV6	
	001400 - 001415	0014	SV7	SV7	
	001500 - 001515	0015	SV8	SV8	
	001600 - 001615	0016	Set/Select of Input/Output Type	<input type="checkbox"/> IO	
	001700 - 001715	0017	Setting of Sensor Value Correction	PVS	
	001800 - 001815	0018	Decimal Point Position	<input type="checkbox"/> DP	
	001900 - 001915	0019	Selection of C/F	<input type="checkbox"/> CF	
	002000 - 002015	0020	Setting of L. Limit of SV Limiter	SLL	
	002100 - 002115	0021	Setting of H.Limit of SV Limiter	SLH	
	002200 - 002215	0022	Setting of Lock Function	LOC	
	002300 - 002315	0023	Control Action Select	CNT	
	002400 - 002415	0024	Proportional band	<input type="checkbox"/> P1	
	002500 - 002515	0025	Integrated time	<input type="checkbox"/> I1	
	002600 - 002615	0026	Differential time	<input type="checkbox"/> D1	
	002700 - 002715	0027	Output 1 P-cycle Time	<input type="checkbox"/> T1	
	002800 - 002815	0028	Control sensitivity	<input type="checkbox"/> C1	
	002900 - 002915	0029	Manual Reset Value	PBB	
	003000 - 003015	0030	Setting of L. Limit for Out 1 MV Limiter	MLL	
	003100 - 003115	0031	Setting of H. Limit for Out 1 MV Limiter	MLH	
	003200 - 003215	0032	Setting for unusual	FAL	
	003300 - 003315	0033	Cooling P-band	PC1	
	003400 - 003415	0034	Cooling P-cycle time	TC1	
	003500 - 003515	0035	Cooling Sensitivity	CC1	
	003600 - 003615	0036	Dead Band	DB1	
	003700 - 003715	0037	Setting of L limit of cooling output	MCL	
	003800 - 003815	0038	Setting of H limit of cooling output	MCH	
003900 - 003915	0039	L limit of cascade scaling	CSL		

Device	Bit Address	Word Address	Controll Setting Item	Identifier	Other
1020_	004000 ~ 004015	0040	H limit of cascade scalling	CSH	
	004100 ~ 004115	0041	Event 1 Function	EV1	
	004200 ~ 004215	0042	PV Event 1 Function	P1F	
	004300 ~ 004315	0043	PV Event 1 Low Limit	P1L	
	004400 ~ 004415	0044	PV Event 1 High Limit	P1H	
	004500 ~ 004500	0045	DI 1 Function	D1F	
	004600 ~ 004615	0046	Event 2 Function	EV2	
	004700 ~ 004715	0047	PV Event 2 Function	P2F	
	004800 ~ 004815	0048	PV Event 2 Low Limit	P2L	
	004900 ~ 004915	0049	PV Event 2 High Limit	P2H	
	005000 ~ 005015	0050	DI2 Function	D2F	
	005100 ~ 005115	0051	Event 3 Function	EV3	
	005200 ~ 005215	0052	PV Event 3 function	P3F	
	005300 ~ 005315	0053	PV Event 3 Low Limit	P3L	
	005400 ~ 005415	0054	PV Event 3 Hight Limit	P3H	
	005500 ~ 005515	0055	DI3 Function	D3F	
	005600 ~ 005615	0056	Event 4 Function	EV4	
	005700 ~ 005715	0057	PV Event 4 Function	P4F	
	005800 ~ 005815	0058	PV Event 4 Low Limit	P4L	
	005900 ~ 005915	0059	PV Event 4 High Limit	P4H	
	006000 ~ 006015	0060	DI4 Function	D4F	
	006100 ~ 006115	0061	Evet 5 Function	EV5	
	006200 ~ 006215	0062	PV Event 5 Function	P5F	
	006300 ~ 006315	0063	PV Event 5 Low Limit	P5L	
	006400 ~ 006415	0064	PV Event 5 High Limit	P5H	
	006500 ~ 006515	0065	DI5 Function	D5F	
	006600 ~ 006615	0066	Selection of Data Transmission 1 Function	TR1	
	006700 ~ 006715	0067	L limit of transmission 1 scalling	T1L	
	006800 ~ 006815	0068	H limit of transmission 2 scalling	T1H	
	006900 ~ 006915	0069	Selection of Data Transmission 2 Function	TR2	
	007000 ~ 007015	0070	L limit of transmission 2 scalling	T2L	
	007100 ~ 007115	0071	H limit of transmission 2 scalling	T2H	
007200 ~ 007215	0072	Close feedback resistance control	CLS		
007300 ~ 007315	0073	Open feedback resistance control	OPN		
007400 ~ 007415	0074	quota of function	FNC		
007500 ~ 007515	0075	Output State Monitor	OM1		
007600 ~ 007615	0076	Event condition monitor	EM1		
		0077	Data Store	STR	

12.8.4 Environment Setup

The following table lists the recommended Controller and GP/GLC communication settings.

GP/GLC Settings		Controller Settings	
Baud Rate	9600 bps	Baud Rate	9600 bps
Data Length	8 bit	Data Length	8 bit
Stop Bit	2 bit	Stop Bit	2 bit
Parity Bit	None	Parity Bit	None
Data Flow Control	ER	_____	_____
Communication Format (using RS-422) *1	RS-422 (2-line)	_____	_____
Communication Format (using RS-232C) *1	RS-232C	_____	_____
Unit No. *2	1 to 32	Communication Unit No.	1 to 32
_____	_____	Mode Setting *3	Communication Mode
_____	_____	Mode Setting *4	Read/Write

*1 Controller cannot switch the Communication Format. When purchasing the Controller, select either an RS-422 or RS-232C.

*2 Although the settable range for a machine number on the temperature controllers is 1 to 99, the range for GP/GLC is 1 to 32.

*3 This setting is required for models other than the TTM-004/X04 series. When you perform communication between the Controller and GP/GLC, be sure to set your Controller to Data Transfer mode.

*4 This setting is required only for the TTM-004/X04 series. When the Controller is set to read-only, rewritable devices will become read-only.

12.8.5 Error Code

Controller error codes are displayed by the “ Host Communication Error (02:**:##)”, and indicated in the left lower corner of the GP/GLC screen ** indicates the Controller’s error code, and ## indicates the number of the Controller unit.

Error Code	Error Message	Meaning
00	Flat of the instrument (Memory error or A/D conversion error)	_____
01	Numeric data out of "the setting range respectively specified in each of setting items".	Data written to an arbitrary device is out of the range for writing.
02	Change of an item prohibited, or no item to be read out.	No device exists in the address specified for the temperature controller connected to GLC or GP. Or, data was written to the specified device, even though that device is write protected.
03	An ASCII code other than the numeric data is specified in the place. Or, an ASCII code other than "0" or "-" is specified in the place for the sign.	_____
04	Format error	The format of the command from the GP/GLC is incorrect due to noise, etc.
05	BCC error	The format of commands sent from GP/GLC is erroneous due to noise or the like.
06	Overrun error	_____
07	Framing error	Machine Numbers for temperature controllers are overlapping. Or, the format of commands sent from GP/GLC is erroneous due to noise or the like.
08	Parity error	The current Data Transfer Parity setting is incorrect. Or, the format of commands sent from GP/GLC is erroneous due to noise or the like.
09	Trouble has happened on PV in process of AT. Or, AT does not be finalized in 3 hours.	_____



Depending on the specification of the Controller, if two errors occur at the same time, the larger error number will be displayed.



For more details about error codes, refer to the TOHO ELECTRONICS INC.'s COMMUNICATIONS FUNCTION Instructon Manual.

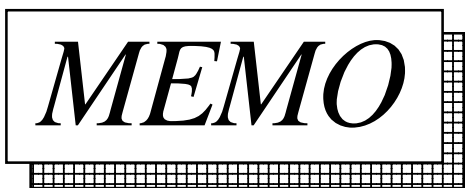

13 Inverters

This chapter shows examples of system configuration, supported devices and environment setup used when connecting the inverters to the GP.



If communication is halted due to signal cable breakage, GP/GLC fault etc., the inverter does not detect such a fault.

13.1 List of Connectable Inverters

The following inverters can be connected to the GP.

Company	Series	Inverter *1	Link I/F or CPU direct connection	PLC Name in Pro/PB III
Mitsubishi Electric Corp.	FREQROL-A500	FR-A520-□K FR-A540-□K		MITSUBISHI FREQROL SERIES
	FREQROL-A500L	FR-A520L-□K FR-A540L-□K		
	FREQROL-E500	FR-E520-□K FR-E540-□K FR-E520S-□K FR-E510W-□K		
	FREQROL-F500	FR-F520-□K FR-F540-□K		
	FREQROL-F500L	FR-F520L-□K FR-F540L-□K		
	FREQROL-S500	FR-S510W-□K-R FR-S520-□K-R FR-S520S-□K-R		
	FREQROL-B,B3	FR-B-□K FR-B3-□□□K		
Fuji Electric Co., Ltd.	FRENICS5000G11S	FRN□□G11S-2		FUJI INVERTER
		FRN□□G11S-4		
	FRENICS5000P11S	FRN□□P11S-2		
		FRN□□P11S-4		
	FVR-E11S	FVR□□□E11S-2		
		FVR□□□E11S-7		
	FVR-C11S	FVR□□□C11S-2	Option OPC-C11S-RS□ *2	
		FVR□□□C11S-6		
FVR□□□C11S-7				

*1 The “□□□” characters in the inverter model codes reflect applicable standard generator capacities.

*2 The “□” character in the option card model code reflects the classification of the card type (either A, B, or C) according to this series inverter capacities.

The model codes' last numbers 2, 4, 6, and 7 indicate 3 phase 200V, 3 phase 400V, single phase 100V, and single phase 200V, respectively.



13.2 Mitsubishi Electric Inverters

13.2.1 System Structure

The following table describes the system structure for connecting the Mitsubishi Electric inverters to the GP.



If communication is halted due to signal cable breakage, GP/GLC fault etc., the inverter does not detect such a fault. Use its Communication retry or Communication check to diagnose the problem and prevent an accident.

■ FREQROL-A500 Series

Inverter	Cable Diagram	GP
FR-A520-□K FR-A540-□K	RS-422 (4-wire) (Cable Diagram 1) RS-422 (4-wire, 1:n communication) (Cable Diagram 2)	GP or GLC Series



“□” indicates the capacity of each inverter.

■ FREQROL-A500L Series

Inverter	Cable Diagram	GP
FR-A520L-□K FR-A540L-□K	RS-422 (4-wire) (Cable Diagram 1) RS-422 (4-wire, 1:n communication) (Cable Diagram 2)	GP or GLC Series

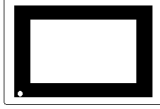

“□” indicates the capacity of each inverter.

■ FREQROL-E500 Series

Inverter	Cable Diagram	GP
		
FR-E520-□K FR-E540-□K FR-E520S-□K FR-E510W-□K	RS-422 (4-wire) (Cable Diagram 1) RS-422 (4-wire, 1:n communication) (Cable Diagram 2)	GP or GLC Series

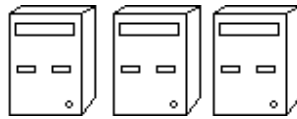

“□” indicates the capacity of each inverter.

■ FREQROL-F500 Series

Inverter	Cable Diagram	GP
		
FR-F520-□K FR-F540-□K	RS-422 (4-wire) (Cable Diagram 1) RS-422 (4-wire, 1:n communication) (Cable Diagram 2)	GP or GLC Series

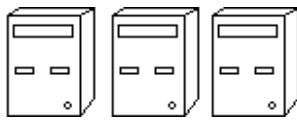

“□” indicates the capacity of each inverter.

■ FREQROL-F500L Series

Inverter	Cable Diagram	GP
		
FR-F520L-□K FR-F540L-□K	RS-422 (4-wire) (Cable Diagram 1) RS-422 (4-wire, 1:n communication) (Cable Diagram 2)	GP or GLC Series



“□” indicates the capacity of each inverter.

■ **FREQROL-S500 Series**

Inverter	Cable Diagram	GP
		
FR-S520-□K FR-S520S-□K FR-S510W-□K	RS-422 (4-wire) (Cable Diagram 1) RS-422 (4-wire, 1:n communication) (Cable Diagram 2)	GP or GLC Series

“□” indicates the capacity of each inverter.

■ **FREQROL-B/B3 Series**

Inverter	Cable Diagram	GP
		
FR-B-□K FR-B3-□□□K	RS-422 (4-wire) (Cable Diagram 1) RS-422 (4-wire, 1:n communication) (Cable Diagram 2)	GP or GLC Series

“□” indicates the capacity of each inverter.

13.2.2 Cable Diagrams

Recommended Cables

For connection of the GLC/GP and Mitsubishi Electric inverters, the following cables and cable manufacturers are recommended:

No.	Item	Model Code	Company	Remark
1	Cable (available on the market)	FR-CB201 (1m)	Mitsubishi Electric Corporation	Used for 1:n connection
2		FR-CB203 (3m)	Mitsubishi Electric Corporation	Used for 1:n connection
3		FR-CB205 (5m)	Mitsubishi Electric Corporation	Used for 1:n connection
4	Wires	SGLPEV 0.5mm×4P	Mitsubishi Electric Corporation	10BASE-T wires
5	RJ45 connector	5-554720-3	Tyco Electronics AMP K.K.	
6	RS-485 distributor (commercial type)	MBJ-8	Hakko Electric Machine Works Co., Ltd.	Used for 1:n connection End Terminal Resistance OFF
		MBJ-8P		Used for 1:n connection End Terminal Resistance ON

Cable Diagram 1

<When using Digital's RS-422 connector terminal adapter GP070-CN10-0>

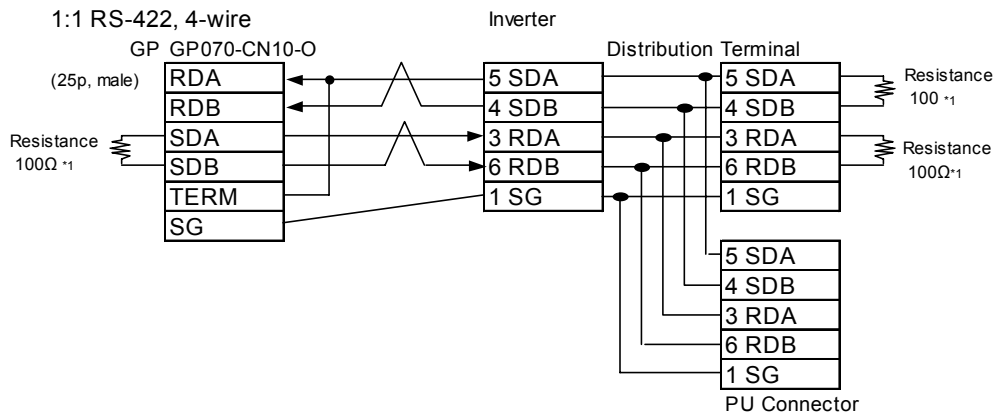

<When making your own cable>

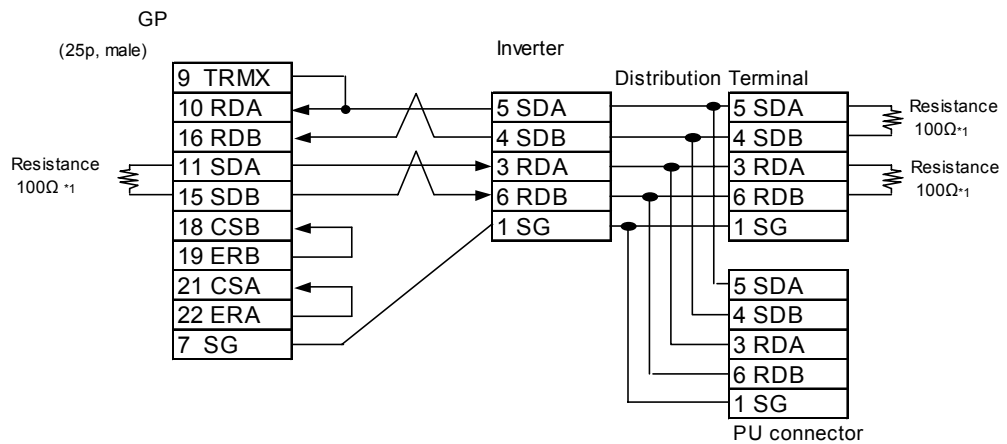

*1 Since a modular connector has been used, be sure to use a distributor when using a terminating resistor.

Cable Diagram 2

<When using Digital's RS-422 connector terminal adapter GP070-CN10-0>

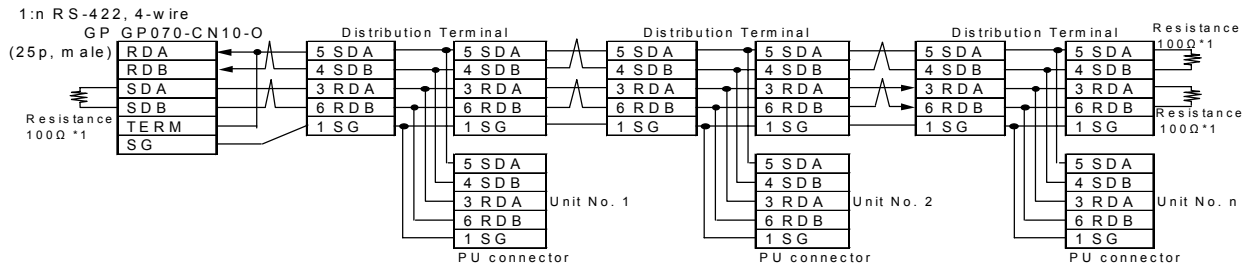

<When making your own cable>

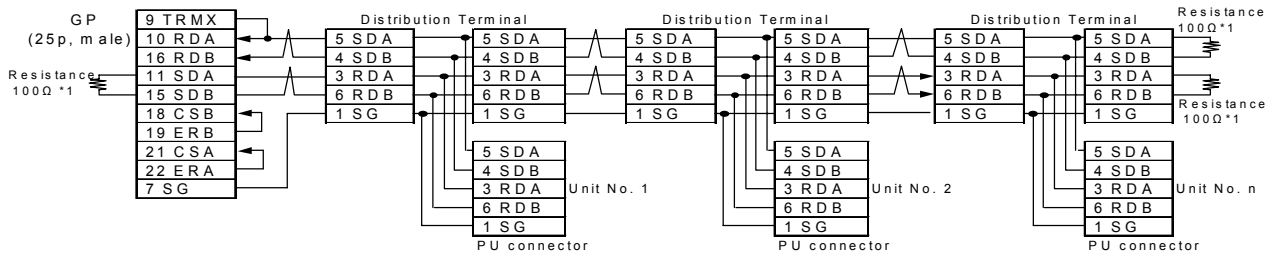

**1 Since a modular connector has been used, be sure to use a distributor when using a terminating resistor.*

13.2.3 Supported Devices

Device	Bit Addresses	Word Addresses	Remarks
Parameter (except for Pr.37 of FREQROL-S500 and FREQROL-E500)	000000 ~ 99315	0000 ~ 0993	*1 *3
Parameter (Pr.37 of FREQROL-S500 and FREQROL-E500)	P0037002 ~ P003731	P0037	*2 *4 H/L
Operation mode	OPE000 ~ OPE015	OPE0	*3
Output frequency (rpm)	OUTF000 ~ OUTF015	OUTF0	H/L
Output current	OUTC000 ~ OUTC015	OUTC0	*3
Output voltage	OUTV000 ~ OUTV015	OUTV0	
Special monitor	SPM000 ~ SPM015	SPM0	
Special monitor selection no.	SSEL000 ~ SSEL015	SSEL	
Output frequency	SOF000 ~ SOF015	SOF0	
Output current	SOC000 ~ SOC015	SOC0	
Output voltage	SOV000 ~ SOV015	SOV0	
Set frequency value	FSET000 ~ FSET015	FSET0	
Run speed	RUNS000 ~ RUNS015	RUNS0	
Motor torque	MOT000 ~ MOT015	MOT0	
Regenerative brake	RBRK000 ~ RBRK015	RBRK0	
Electronic thermal load factor	ELOF000 ~ ELOF015	ELOF0	
Output current peak value	OCPV000 ~ OCPV015	OCPV0	
Converter output voltage peak value	COPK000 ~ COPK015	COPK0	
Input power	IPOW000 ~ IPOW015	IPOW0	
Output power	OPOW000 ~ OPOW015	OPOW0	
Alarm (latest Nos. 1 & 2)	A12D000 ~ A12D015	A12D0	
Alarm (latest Nos. 3 & 4)	A34D000 ~ A34D015	A34D0	
Alarm (latest Nos. 5 & 6)	A56D000 ~ A56D015	A56D0	
Alarm (latest Nos. 7 & 8)	A78D000 ~ A78D015	A78D0	
Run command	RUNC000 ~ RUNC015	RUNC0	
Inverter status monitor	INVS000 ~ INVS015	INVS0	
Run frequency write (E ² PROM)	RWRT000 ~ RWRT015	RWRT0	
Set frequency write (RAM and E ² PROM)	SFWE000 ~ SFWE015	SFWE0	
Set frequency write (only RAM)	SFWR000 ~ SFWR015	SFWR0	
Set frequency read (E ² PROM)	SFRE000 ~ SFRE015	SFRE0	
Set frequency read (RAM)	SFRR000 ~ SFRR015	SFRR0	
Error all clear	ERCL000 ~ ERCL015	ERCL0	
Inverter reset	RSET000 ~ RSET015	RSET0	
Parameter all clear	ALLC000 ~ ALLC015	ALLC0	
User clear	ALLC000 ~ ALLC015	ALLC0	Write data H9669
Link parameter extended settings	LNKP000 ~ LNKP015	LNKP0	
No. 2 parameter change	SECP000 ~ SECP015	SECP0	

*1 For the detailed information about the parameters, refer to Mitsubishi Electric's multi-purpose inverter manuals.

*2 For the FREQROL-S500 parameter, designate "SP" as the device name and enter the parameter number as the address.

*3 This device cannot be used as 32 bit data.

*4 The supported devices and their corresponding items described in an inverter manuals are as follows:

[Parameter read/write]

Function	Parameter Number	Name	Data Code		
			Read	Write	Link Parameter Extension Setting Value (Data Code: 7F/FF)
Basic Functions	0	Torque boost	00	80	0
	1	Maximum frequency	01	81	0
	2	Minimum frequency	02	82	0
	3	Base frequency	03	83	0

Excerpted from Mitsubishi Transistorized Inverter FREQROL-A500 Operation Manual; Appendix 1. Data Code List

[Devices other than the parameters]

Select an applicable device from the supported device list.

No.	Item	Command Code	Data	Number of Data Digits
1	Operation mode	Read H7B	H0000: Communication option operation H0001: External operation H0002: Communication operation (PU connector)	4 digits
		Write HFB	H0000: Communication option operation H0001: External operation H0002: Communication operation (PU connector)	
2	Monitoring Output frequency [speed]	H6F	H0000 to HFFFF: Output frequency (hexadecimal) in 0.01Hz increments	4 digits

Excerpted from Mitsubishi Transistorized Inverter FREQROL-A500 Operation Manual; Computer Link Operation <Setting Items and Set Data>.

*5 How to Enter a Device Name

Enter a device name on the GP screen editor software, as follows:

Device
When reading/writing a parameter, select either "..." or "SP".

Address
Fixed to "0" except when reading/writing a parameter.

Inverter unit number

*6 Depending on the parameter type, “9999” (indicates parameter settings are ineffective) or other values may be entered. In such a case, data write/read from the GLC/GP will become as follows:

Parameter Set Value Read/Write Data List

No.	Inverter Model	Inverter Set Value	Written Data	Read Data	Remark
1	Except for FR-S500	9999	-1 (0xFFFF)	-1 (0xFFFF)	
2		8888	-16 (0xFFFF0)	-16 (0xFFFF0)	
3	FR-S500	— — —	-1 (0xFFFF)	-1 (0xFFFF)	
4		888	-16 (0xFFFF0)	-16 (0xFFFF0)	

*8 The system area (20 words) cannot be used.

Also, on the GP/GLC offline screens and the screen editor software's system area selection screen, the protocol and operation procedure display will be the same as those appear when the system area can be used. Even if you select the system area on these screens, however, it will automatically be designated as not selected.

13.2.4 Environment Setup

The following tables show Digital's recommended Mitsubishi Electric inverter communication settings and their corresponding settings on the GP.

GP/GLC Settings		Inverter Settings	
Baud Rate	19200bps	Baud Rate	19200bps
Data Length	8bit	Data Length	8bit
Stop Bit	2bit	Stop Bit	2bit
Parity Bit	Even	Parity Bit	Even
Data Flow Control	ER	_____	_____
Communication Format When using RS-422	RS-422 (4-wire)	_____	_____
Unit No.*1	0 ~ 31	Unit No.	0 ~ 31

◆ **Setting Method**

Use the inverter's front keys to enter communication settings.

Use parameters 117 to 124 for the inverter communication settings, as follows:

No.	Parameter No.	Name	Setting Range
1	117	Station number	0 ~ 31
2	118	Communication Speed	48...4800bps 96...9600bps 192...1920bps
3	119	Stop bit length/Data length	0...8/1 1...8/2 10...7/1 11...7/2
4	120	Parity check Presence/Absence	0: OFF 1: Even 2: Odd
5	121	Number of communication retries	0 ~ 10,9999 or ---
6	122	Communication check time internal	0 ~ 999.8,9999 or ---
7	123	Waiting time settings	0 ~ 150,9999 or ---
8	124	CR, LF Presence/Absence selection	0: CR and LF OFF 1: CR ON 2: CR and LF ON

13.2.5 Error Codes

<Error Codes Specific to Inverters>

The following error numbers are supported by the inverters. Each error number (format = 02:OO:ΔΔ) will be displayed on the left bottom of the GLC/GP screens. (The “OO” characters reflect an error number displayed on the GLC/GP (shown in the table below) and the “ΔΔ” characters reflect an inverter unit number where the error occurs.)

Reference *Mitsubishi Electric Corporation; Each inverter series’ Operation Manual*

Error No.	Error Name	Causes
00	Computer NAK error	_____
01	Parity error	The GLC/GP parity settings are incorrect.
02	Sum check error	An error occurred on communication data due to noise, etc.
03	Protocol error	_____
04	Flaming error	An error occurred on communication data due to noise, etc., or the stop bit settings are incorrect.
05	Overrun error	_____
06	_____	_____
07	Character error	_____
08	_____	_____
09	_____	_____
0A	Mode error	Parameter write was attempted when the mode is not the computer link operation mode or while the inverter is operating.
0B	Instruction code error	A non-existent address has been designated during screen creation.
0C	Data range error	When parameter or operation frequency data was written, the designated data was exceeded the correct setting range.
0D	_____	_____
0E	_____	_____
0F	_____	_____

Depending on the inverter specifications, when multiple errors occurred simultaneously, the larger error number will be displayed.

13.3 Fuji Electric Inverters

13.3.1 System Structure

The following describes the system configuration used when connecting the Fuji Electric inverters to the GP.



- If a communication error occurs while the unit is operating via RS-485, a stop command may not be recognized via RS-485. To prevent any accidents, be sure to use the inverter external signal terminal's forced stop function so that emergency stop will always be effective.
- If an alarm is reset with a run command sent via RS-485, the unit will suddenly restart. To prevent accidents, be sure to confirm that the run command is no longer being sent anymore.

■ FRENICS5000G11S Series

Inverter *1	Cable Diagram	GP
FRN□□G11S-2 FRN□□G11S-4	RS-485 (1:1) (Cable Diagram 1) RS-485(1:n) (Cable Diagram 2)	GP Series GLC Series



■ FRENICS5000P11S Series

Inverter *1	Cable Diagram	GP
FRN□□P11S-2 FRN□□P11S-4	RS-485 (1:1) (Cable Diagram 1) RS-485(1:n) (Cable Diagram 2)	GP Series GLC Series



*1 The “□□□” characters in the inverter model codes reflect applicable standard generator capacities.

*2 The “□” character in the option card model code reflects the classification of the card type (either A, B, or C) according to this series inverter capacities.

■ FVR-E11S Series

Inverter *1	Cable Diagram	GP
		
FVR□□□E11S-2 FVR□□□E11S-7	RS-485 (1:1) (Cable Diagram 3) RS-485(1:n) (Cable Diagram 4)	GP Series GLC Series

■ FVR-C11S Series (Optional for Communication)

Inverter *1	Communication I/F	Cable Diagram	GP
			
FVR□□□C11S-2 FVR□□□C11S-6 FVR□□□C11S-7	Option: OPC-C11S-RS□ ^{*2}	RS-485 (1:1) (Cable Diagram 1) RS-485(1:n) (Cable Diagram 2)	GP Series GLC Series

*1 The “□□□” characters in the inverter model codes reflect applicable standard generator capacities.

*2 The “□” character in the option card model code reflects the classification of the card type (either A, B, or C) according to this series inverter capacities.

13.3.2 Cable Diagrams



- *The following cables are recommended:*

<For G11S, P11S, C11S>

Furukawa Electric UL AWM2789 1/0.65 mm² long distance braided shield cable

< For E11S>

Cable conforming to EIA568 standard (for 10BASE-T), as well as RJ45 connector

- *The maximum length of a cable (transmission distance) is 500m.*
- *Depending on the usage environment, a unit may malfunction due to the noise generated from the inverter. In such a case, connect a ferrite core or condenser to the cable.*

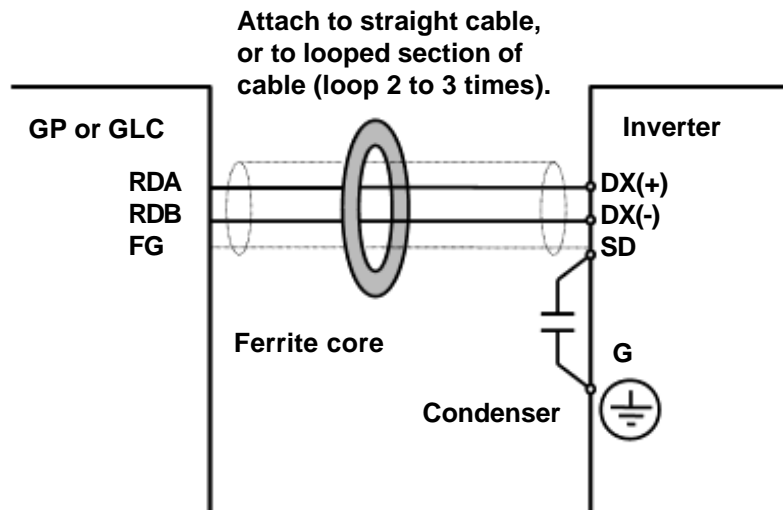

- *A terminating resistor (100Ω) has been embedded in the E11S. When connecting the inverter to the end of the cable, turn ON SW2 located below the connector.*

Cable Diagram 1 (1:1)

<When using Digital's RS-422 connector terminal adapter GP070-CN10-0>

1:1 RS-422, 2 wires

**GP (25p, male)
GP070-CN10-0**

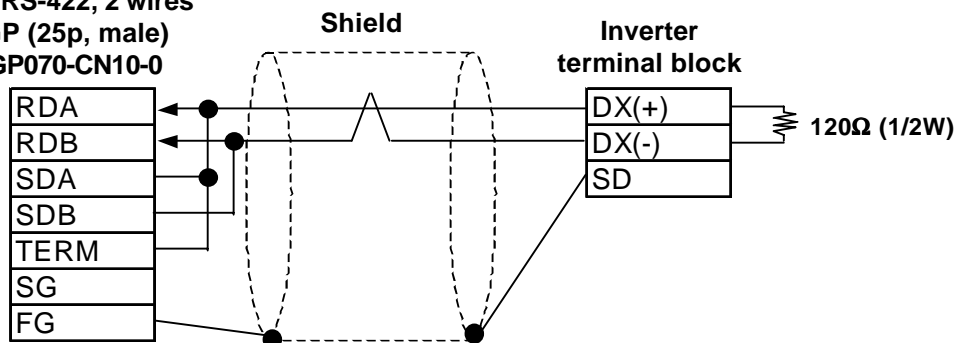

<When using Digital's RS-422 connector terminal adapter GP070-CN10-0>

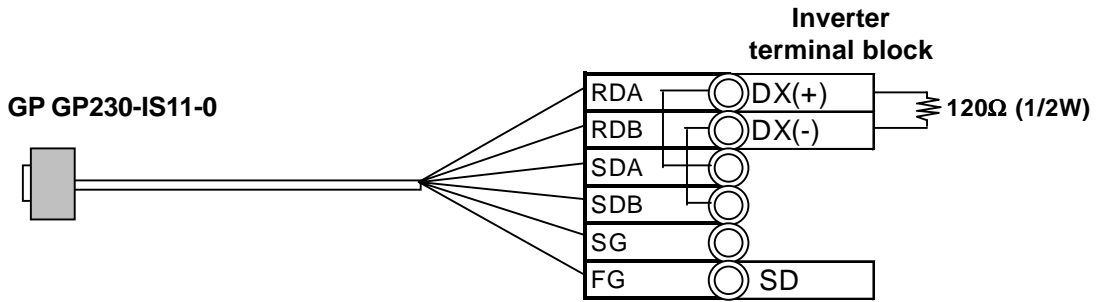

<When making your own cable>

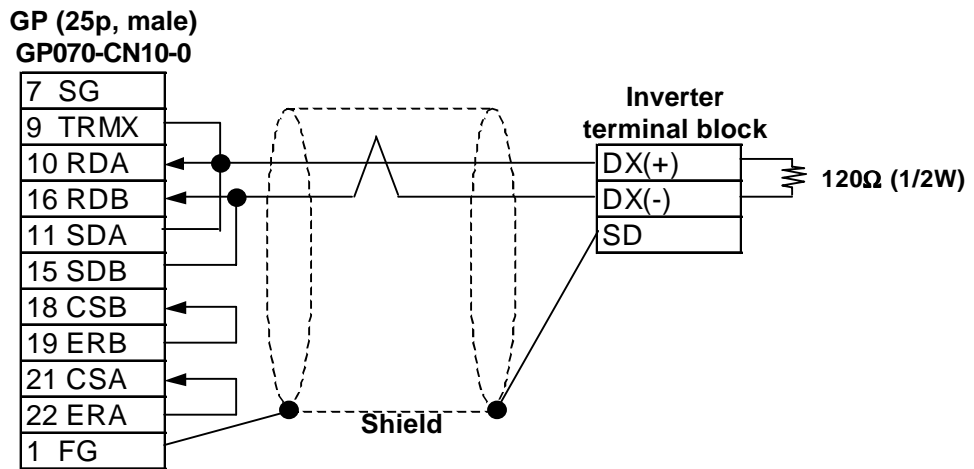

Cable Diagram 2 (1:n)

<When using Digital's RS-422 connector terminal adapter GP070-CN10-0>

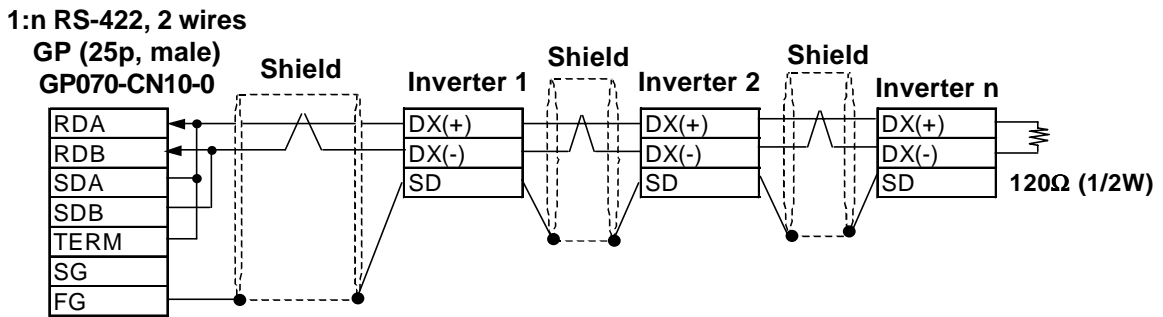

<When making your own cable>

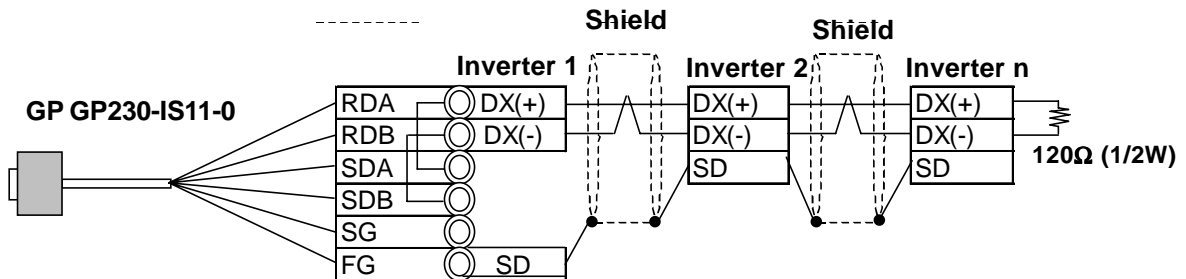

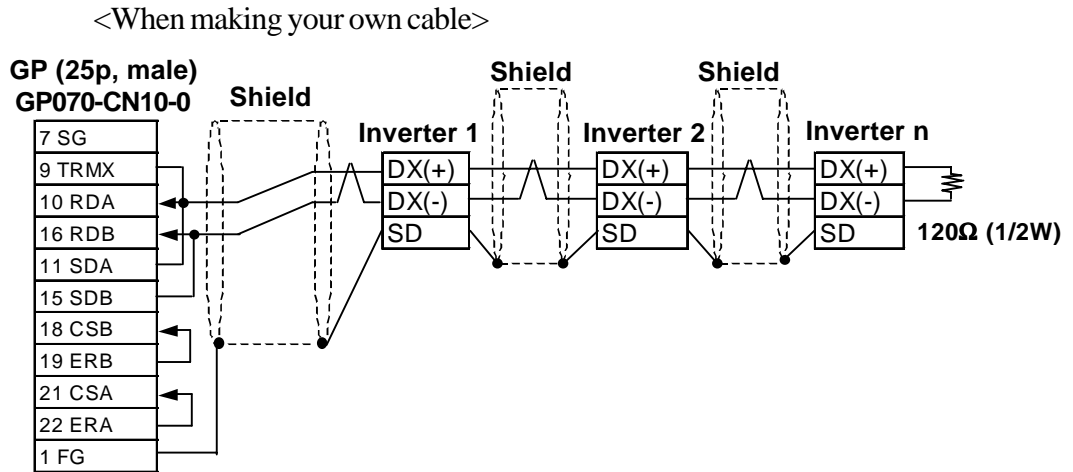

Cable Diagram 3 (1:1)

<When using Digital's RS-422 connector terminal adapter GP070-CN10-0>

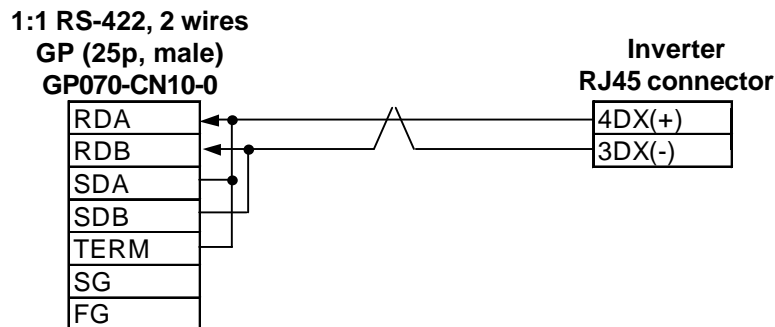

<When making your own cable>

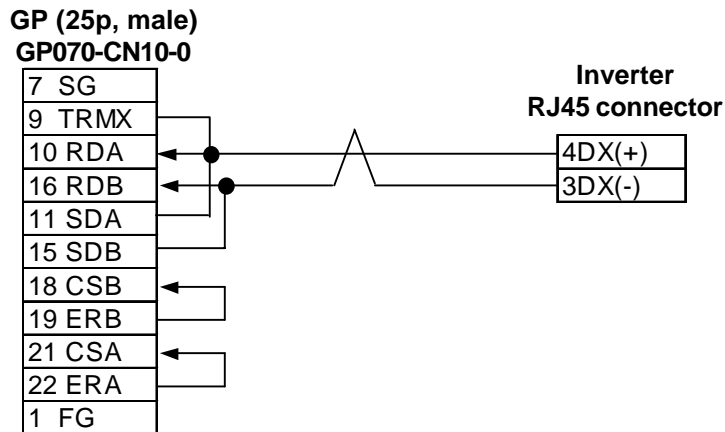

Cable Diagram 4 (1:n)

<When using Digital's RS-422 connector terminal adapter GP070-CN10-0>

1:n RS-422, 2 wires

GP (25p, male)

GP070-CN10-0

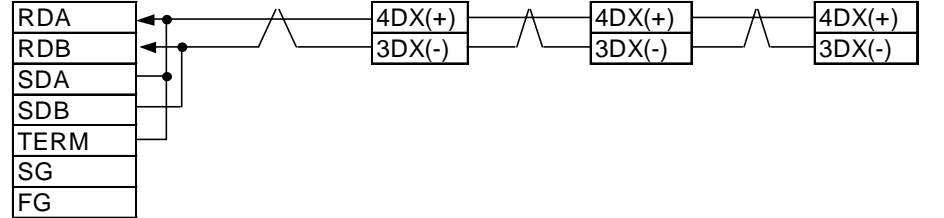

<When making your own cable>

GP (25p, male)

GP070-CN10-0

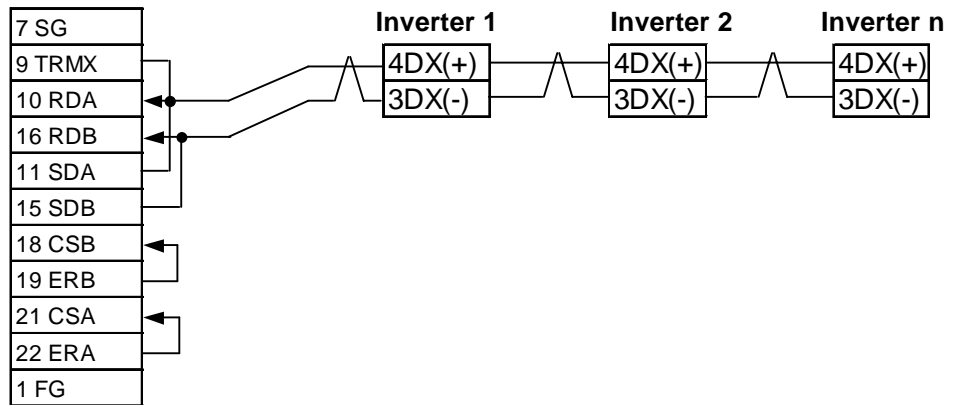

13.3.3 Supported Devices

■ FRENICS5000G11S/FRENICS5000P11S Series

Device	Bit Addresses	Word Addresses	Remarks	
Basic function	F0000 ~ F4215	F00 ~ F42	L/H	
Terminal function	E0100 ~ E4715	E01 ~ E47		
Controlling function	C0100 ~ C3315	C01 ~ C33		
Motor 1	P0100 ~ P0915	P01 ~ P09		
High level function	H0300 ~ H3915	H03 ~ H39		
Motor 2	A0100 ~ A1815	A01 ~ A18		
Option	o0000 ~ o2915	o00 ~ o29		
Command data	S0100 ~ S1115	S01 ~ S11		
Monitor data	M0100 ~ M4815	M01 ~ M48		*1
Alarm reset	—————	m00		*2

*1 Data write cannot be performed.

*2 “m00” is a virtual device and is used to reset the history of alarms occurred on the inverter.

Writing any data to “m00” will reset the alarm. However, data read cannot be performed.

■ FRENICS5000E11S Series

Device	Bit Addresses	Word Addresses	Remarks	
Basic function	F0000 ~ F4215	F00 ~ F42	L/H	
Terminal function	E0100 ~ E4215	E01 ~ E42		
Controlling function	C0100 ~ C3315	C01 ~ C33		
Motor 1	P0100 ~ P1015	P01 ~ P10		
High level function	H0100 ~ H4615	H01 ~ H46		
Motor 2	A0100 ~ A1915	A01 ~ A19		
Command data	S0100 ~ S1115	S01 ~ S11		
Monitor data	M0100 ~ M4815	M01 ~ M48		*1
Alarm reset	—————	m00		*2

*1 Data write cannot be performed.

*2 “m00” is a virtual device and is used to reset the history of alarms occurred on the inverter.

Writing any data to “m00” will reset the alarm. However, data read cannot be performed.

■ FRENICS5000G11S/FRENICS5000P11S Series

Device	Bit Addresses	Word Addresses	Remarks	
Basic function	F0000 ~ F3615	F00 ~ F36	L/H	
Terminal function	E0100 ~ E0315	E01 ~ E03		
Controlling function	C0100 ~ C0715	C01 ~ C07		
Motor 1	P0000 ~ P0015	P00		
High level function	H0100 ~ H2515	H01 ~ H25		
Option	O0000 ~ O1115	o00 ~ o11		*1
Command data	S05 ~ S06	S05 ~ S06		
Monitor data	M0100 ~ M4815	M01 ~ M48		*1
Alarm reset	—————	m00	*2	

*1 Data write cannot be performed.

*2 “m00” is a virtual device and is used to reset the history of alarms occurred on the inverter.

Writing any data to “m00” will reset the alarm. However, data read cannot be performed.



- The system area (20 words) cannot be used. Also, on the GP/GLC offline screens and the screen editor software’s system area selection screen, the protocol display and operation will be the same as that which appears when the system area can be used. Even if the system area is selected on these screens, however, it will automatically be designated as not selected.
- Depending on the inverter series, supported functions and ranges will vary. For more detailed information, refer to each inverter series’ operation manual.
- On GP-PRO/PB III, enter the device address and station address as follows:

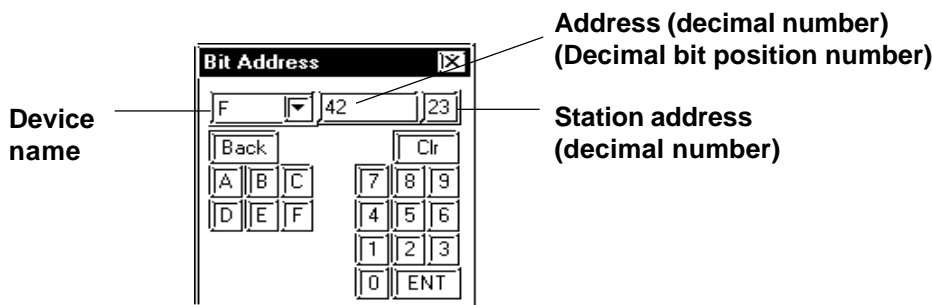

13.3.4 Environment Setup

■ FRENICS5000G11S/FRENICS5000P11S Series

GP/GLC Settings		Inverter Settings		Setting Function
Baud Rate	9600bps	Baud rate	9600bps	H34
Data Length	8bit	Data Length	8bit	H35
Stop Bit	2bit	Stop Bit	2bit	H37
Parity Bit	None	Parity Bit	None	H36
Data Flow Control	ER	_____	_____	_____
Communication Format	2-wire type	_____	_____	_____
Station Address	1 ~ 31	Station Address	1 ~ 31	H31

■ FVR-E11S Series

GP/GLC Settings		Inverter Settings		Setting Function
Baud Rate	9600bps	Baud rate	9600bps	H34
Data Length	8bit	Data Length	8bit	H35
Stop Bit	1bit	Stop Bit	1bit	H37
Parity Bit	None	Parity Bit	None	H36
Data Flow Control	ER	_____	_____	_____
Communication Format	2-wire type	_____	_____	_____
Unit No.	1 ~ 31	Station Address	1 ~ 31	H31

■ FVR-C11S Series

GP/GLC Settings		Inverter Settings		Setting Function
Baud Rate	9600bps	Baud rate	9600bps	o04
Data Length	8bit	Data Length	8bit	o05
Stop Bit	2bit	Stop Bit	2bit	o07
Parity Bit	None	Parity Bit	None	o06
Data Flow Control	ER	_____	_____	_____
Communication Format	2-wire type	_____	_____	_____
Unit No.	1 ~ 31	Station Address	1 ~ 31	o01
_____	_____	Optional selection	1	o00



- The FVR-C11S Series requires a communication card (Model: OPC-C11S-RS*). Be sure to set “o00” to 1 to enable the RS-485 communication option.

13.3.5 Error Codes

<Error Codes Specific to Inverters>

The error codes specific to the inverters will appear on the GP screen’s left bottom, as “Host Communication Error (02:**:##)”. (The “**” characters indicate an error code specific to the inverter, and the “##” characters indicate the station address of the inverter on which an error occurred.)

■ Error Codes

Error Code	Error Name	Description
4AH	Format error	<ul style="list-style-type: none"> Data transmission request statement characters are incorrect. The last character of the request statement is not in the correct position.
4BH	Command error	<ul style="list-style-type: none"> A non-existent command has been sent.
4CH	Link priority error	<ul style="list-style-type: none"> It was attempted to write command or operation command data, with the link option installed. (When the link option has been installed, the command and operation command data cannot be written via RS-485.)
4DH	No write authorization error	<ul style="list-style-type: none"> It was attempted to write new function data during data write from the link option.
4EH	Function code error	<ul style="list-style-type: none"> A non-existent function code has been requested.
4FH	Write inhibit error	<ul style="list-style-type: none"> It was attempted to write an operation inhibit function or write inhibit during run function while the unit was operating.
50H	Data error	<ul style="list-style-type: none"> Data that has been written was exceeded an effective range.
51H	Write error	<ul style="list-style-type: none"> It was attempted to write new function data during writing another function.



- **The latest communication error code has been stored in M26.**
- **Alarms occurred on the inverter will have either code numbers M16, M17, M18, or M19.**

M16: Latest alarm

M17: Previous alarm

M18: Alarm before the previous alarm

M19: Alarm before the two old alarms

For more detailed information, refer to your inverter’s operation manual.

14 Connecting to the GP-H70

14.1 Connecting a GP-H70 Series Unit

■ GP-H70 Optional Items

The following optional cables and cable conversion adapters below can be used to connect a PLC to a GP-H70.

ITEM	DESCRIPTION
GP-H70 Option Cable [RS-232C type] GPH70-C232-0 (3m) GPH70-C232-MS (10m)	Included in this cable are the power line to the GP-H70; the communications lines(RS-232C) used with various Host (PLC)s; the GP-H70's DOUT signal line, as well as other lines.This cable has no PLC connector attached so the user can set up the cable's PLC side wires to suit any type or PLC connector.
GP-H70 Option Cable [RS-422 type] GPH70-C422-0 (3m) GPH70-C422-MS (10m)	Included in this cable are the power line to the GP-H70; the communications lines(RS-422) used with various Host (PLC)s; the GP-H70's DOUT signal line, as well as other lines.This cable has no PLC connector attached so the user can set up the cable's PLC side wires to suit any type or PLC connector.
GP-H70 Option Cable [RS-232C type] GPH70-D232 (3m) GPH70-D232-MS (10m)	Included in this cable are the power line to the GP-H70; the commnications lines (RS-232C) used with various Host (PLC)s; the GP-H70's DOUT signal line, as well as other lines. This cable's PLC side connector is a standard DSUB25 pin type.
GP-H70 Option Cable [RS-422 type] GPH70-D422 (3m) GPH70-D422-MS (10m)	Included in this cable are the power line to the GP-H70; the commnications lines (RS-422) used with various Host (PLC)s; the GP-H70's DOUT signal line, as well as other lines. This cable's PLC side connector is a standard DSUB25 pin type.
GP-H70 Conversion Adapter [RS232C] (GPH70-AP232-0)	This adapter is used to convert the wiring from the GP-H70 to either a D-sub25 or standard a terminal block connector. Digital's 232C cable (GP410-IS00-O) can be connected to the D-sub25 connector, and Digital's GPH70-D232 cable can be used to connect the adapter to the GP-H70 unit.
GP-H70 Conversion Adapter [RS422] (GPH70-AP422-0)	This adapter is used to convert the wiring from the GP-H70 to either a D-sub25 or standard a terminal block connector. Digital's GPH70-D422 cable can be used to connect the adapter to the GP-H70 unit.

■ Connection Methods

Every optional cable will require some preparation before it can be used. Digital’s Connection Manual “Chapter 2. Connecting Each PLC with the GP” includes connection diagram(s) of the wiring connections used between the GP and PLC. However, the pin number assigned to each connector pin on the GP-H70’s interface will differ from that of other GP series unit. Therefore, be sure to use Connector Pin Comparison Tables 1 and 2 below when creating a cable used between the GP-H70 and the PLC. An additional cable will be required to supply electric power to the GP-H70.

Comparison Tables 1 and 2 correspond to option cables <GPH70-C232-0> and <GPH70-C422-0>, respectively.

Comparison Table 1 GPH70-C232-0 (RS-232C)

GPH70 Pin No.	Signal name	Wire Color	Mark Band Color/Q'ty	Non-GPH70 Pin No.
1	RS	Purple	White (1band)	Pin 4
2	CS	Orange	White (2bands)	Pin 5
3	CD	Brown	White (2 bands)	Pin 8
19	SD	White	Blue (1band)	Pin 2
20	RD	Blue	Red (2bands)	Pin 3
21	ER	Green	white (2 bands)	Pin 20
22	SG	Black	—	Pin 7
case	FG	Outer Shield	—	Pin 1

Comparison Table 2 GPH70-C422-0 (RS-422)

GPH70 Pin No.	Signal name	Wire Color	Mark Band Color/Q'ty	Non-GPH70 Pin No.
5	TRMX	Pink	—	Pin 9
6	RDA	White	—	Pin 10
7	SDA	Orange	White (1bands)	Pin 11
8	CSA	Brown	White (1bands)	Pin 21
9	ERA	Red	White (1bands)	Pin 22
24	RDB	Blue	Red (1 bands)	Pin 16
25	SDB	Green	White (1bands)	Pin 15
26	CSB	Gray	White (1bands)	Pin 18
27	ERB	Black	White (1bands)	Pin 19
22	SG	Black	—	Pin 7
Case	FG	Outer Shield	—	Pin1



- Be sure to connect this unit’s SG/GND (Signal Ground) terminal to the other unit’s Signal Ground terminal.
- When making a cable, please be aware of the following:
 <For RS-422 Connection>
 - The following pairs of pin #'s must be connected to each other
 ...#26 (CBS) <->#27 (ERB)
 ...#8 (CSA) <-> #9 (ERA)
 - When connecting the RS-422 cable and the #5 (TRMX) and #6 (RDA) points, a termination resistance of 100Ω is added between RDA and RDB.



- When the GP is set as a Memory Link type and the cable type is RS-422, a 4-wire system must be used.

<For RS-232C Connection>

- Do not connect #5 (TRMX), #6 (RDA), #7 (SDA), #25 (SDB), #24 (RDB), #26 (CBS), #27 (ERB), #8 (CSA), #9 (ERA).

The following describes an example of converting the pin assignments for other GP series to those on the GP-H70. The following example connects a GP-H70 with a Mitsubishi PLC (p.2-1-10 <Cable Diagram 1>).

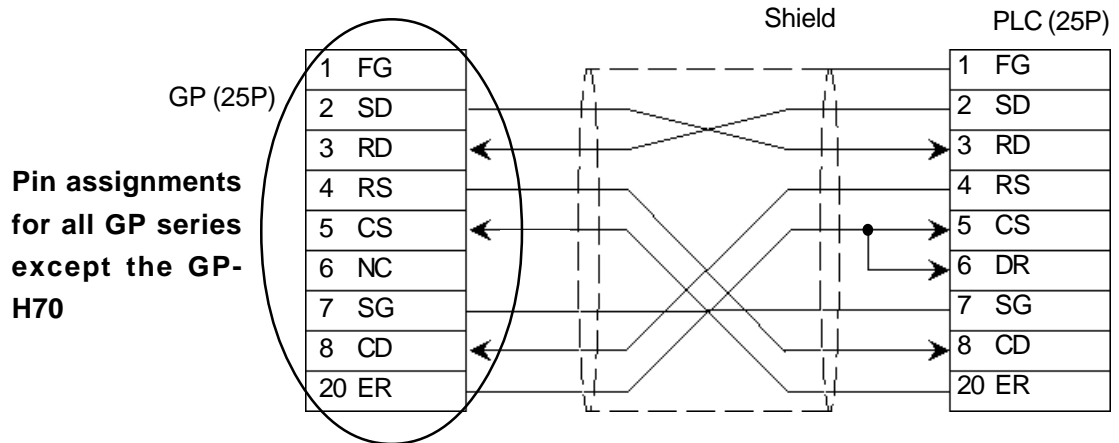

Pin assignments for all GP series except the GP-H70

When using GP-H70 optional cable (GPH70-C232-0)

Pin assignments for the GP-H70 converted from those of other GP series

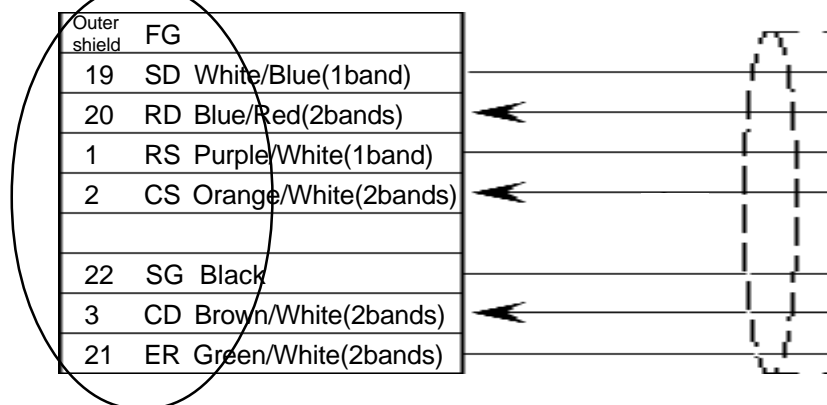

Important

- If any wires in the above table's "Wire Color" column are not used, be sure those wires do not touch other signal wires or the connector case.
- Be sure to connect the cable's outer shield to the FG wire (field ground).

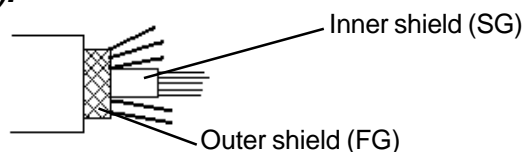

- Be sure to connect the inner shield to the external device's signal ground, in the same way as the Pin 22's SG connection.



14.2 System Design

The diagram below shows the GP unit's peripheral equipment.

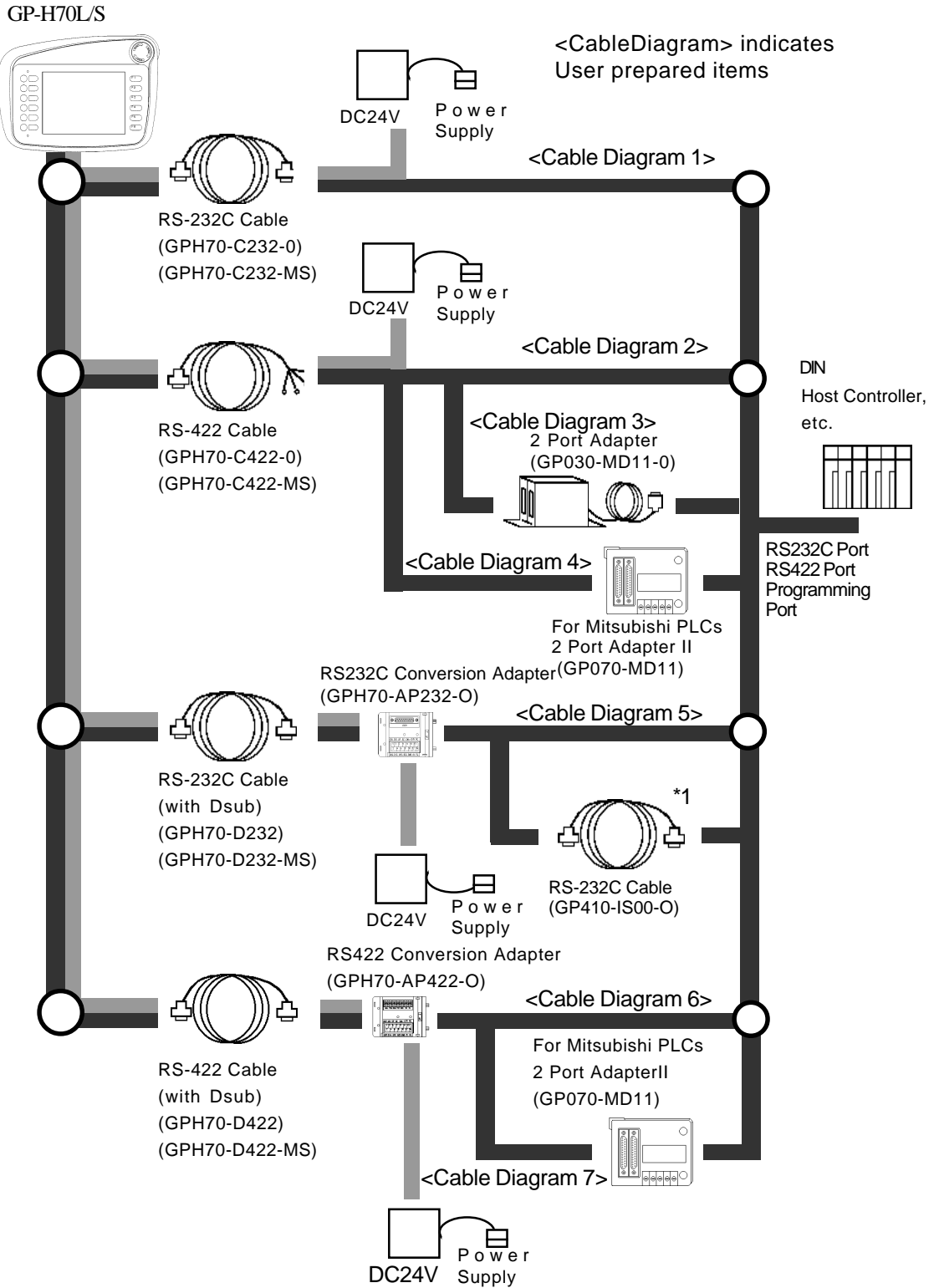

In the above system design diagram, the **thick grey line** indicates power supply routes. Be sure to supply electricity through conversion adapters or cables.

**1 This cable may not be able to be connected to some PLCs. Be sure to check compatibility before connecting.*



14.3 Cable Diagrams

The connection diagram of wiring connections used between the equipment described in “14-2. System Design Diagram” is shown below. This connection diagram only shows those sections used for connecting to the PLC.



- ***Be sure to connect this cable while the GP-H70's power is turned OFF, otherwise an electrical shock may occur.***
- ***When live lines are either connected or disconnected, if a difference in potential is created between the GP-H70 and the connected device(s), the driver IC may be damaged. Therefore, be sure to connect this cable while the GP-H70's power is turned OFF.***
- ***Since the GP-H70 interface signal wires and the GP power supply wires are contained inside a single cable, power supply noise may occur. Therefore, be sure to take appropriate precautions to prevent the connected device(s) from being interrupted by noise. (i.e. install a noise filter, etc.)***

<Cable Diagram 1>

- When connecting GP-H70 to PLC with GPH70-C232-O (3m) or GPH70-C232-MS (10m)

GP-H70

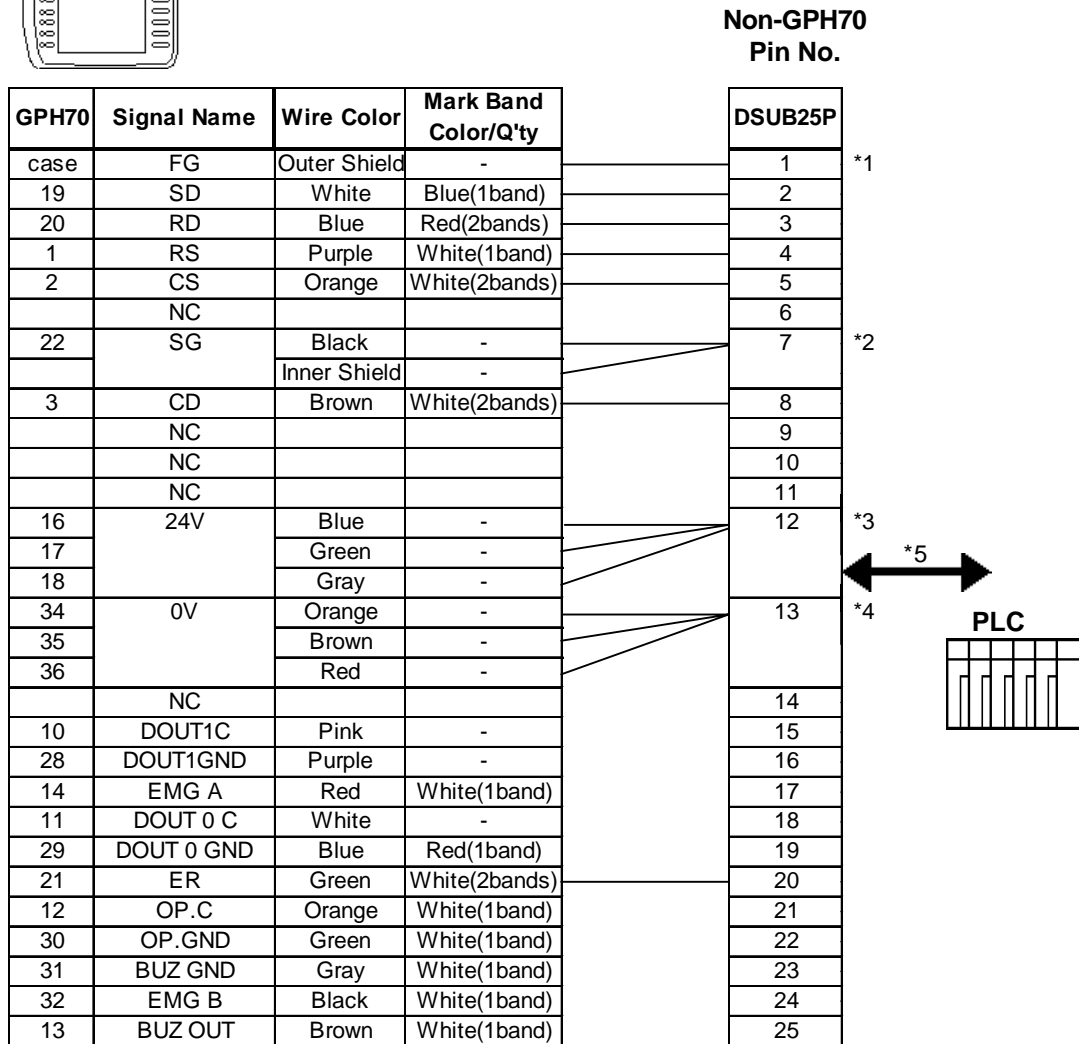
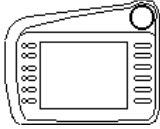

- *1 Connect the cable's outer shield to Pin 1.
- *2 Connect the cable's inner shield and all black wires to Pin 7.
- *3 Connect all the blue, green, and gray wires to Pin 12.
- *4 Connect all the orange, brown, and red wires to Pin 13.
- *5 Refer to the cable diagrams in **Chapter 2 PLC-GP Connection**.



- The wiring arrangement shown above cannot be used with the RS232C cable's Conversion Adapter.
- To connect the Conversion Adapter, the wiring diagram in the GP-H70's RS232 Conversion Adapter's Operation Instructions manual must be used.
- The customer will need to perform this cable's PLC connector wiring. The wires used this cable are AWG 28 (dia.=0.3mm/area-0.08mm²). Using a solder cap tape connector is recommended.
- Be sure the wires do not touch other signal wires or connector case when they are not used.

<Cable Diagram 2>

- When connecting GP-H70 to PLC with GPH70-C422-O (3m) or GPH70-C422-MS (10m)

GP-H70

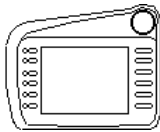

Non-GPH70
Pin No.

GPH70	Signal Name	Wire Color	Mark Band Color/Q'ty	DSUB25P
case	FG	Shield	-	1
10	DOUT 1C	Yellow	Black(1band)	2
28	DOUT 1 GND	Pink	Black(1band)	3
11	DOUT 0 C	Purple	White(1band)	4
29	DOUT 0 GND	White	Blue(1band)	5
12	OP. C	Blue	Red(2bands)	6
22	SG	Black	-	7
30	OP. GND	Orange	White(2bands)	8
5	TRMX	Pink	-	9
6	RDA	White	-	10
7	SDA	Orange	White(1band)	11
16	24V	Pink	Black(2bands)	12
17		White	Blue(2bands)	
18		Orange	Black(1band)	
34	0V	Purple	White(2bands)	13
35		Blue	Black(1band)	
36		Green	Black(1band)	
	NC		-	14
25	SDB	Green	White(1band)	15
24	RDB	Blue	Red(1band)	16
14	EMG A	Gray	White(2bands)	17
26	CSB	Gray	White(1band)	18
27	ERB	Black	White(1band)	19
	NC		-	20
8	CSA	Brown	White(1band)	21
9	ERA	Red	White(1band)	22
31	BUZ GND	Brown	White(2bands)	23
32	EMG B	Red	White(2bands)	24
13	BUZ OUT	Green	White(2bands)	25

- *1 Connect the cable's outer shield to Pin 1.
- *2 Connect all the pink(black/1band), white(blue/2band) and orange(black/1band) wires to Pin 12.
- *3 Connect all the purple(white/2bands), blue(black/1band) and green(black/1band) wires to Pin 13.
- *4 Refer to the cable diagrams in **Chapter 2 PLC-GP Connection**.



- The wiring arrangement shown above cannot be used with the RS232C cable's Conversion Adapter.
- To connect the Conversion Adapter, the wiring diagram in the GP-H70's RS232 Conversion Adapter's Operation Instructions manual must be used.
- The customer will need to perform this cable's PLC connector wiring. The wires used for this cable are AWG 28 (dia.=0.3mm/area-0.08mm²). Using a solder cap tape connector is recommended.
- Be sure these wires do not touch other signal wires or the connector case when they are not used.

<Cable Diagram 3>

- When connecting GP-H70 to 2 Port Adapter (GP030-MD11-0) with GPH70-C422-O (3m) or GPH70-C422-MS (10m)

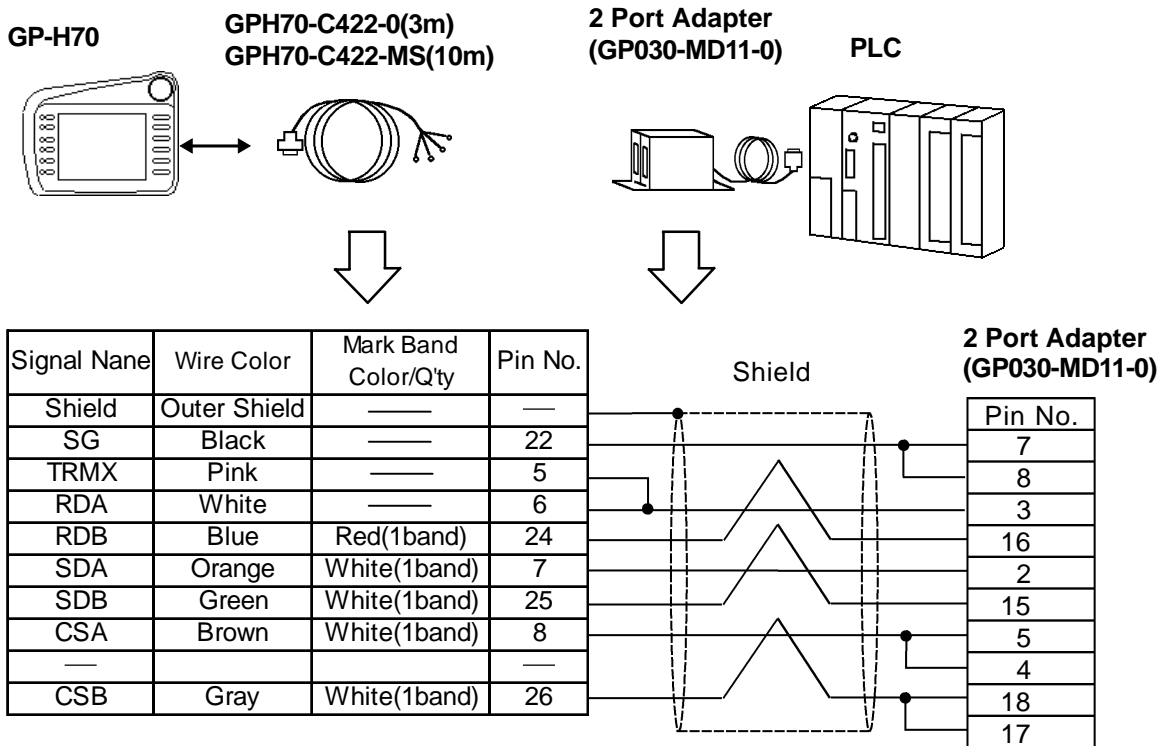

[GP-H70 series]

Pin numbers shown here represent the GP-H70 unit's connection pins.

[2 Port Adapter]

Pin numbers shown here represent the Digital's 2 Port Adapter's (GP030-MD11-0) connection pins.



Note: Be sure the wires do not touch other signal wires or connector case when they are not used.

<Cable Diagram 4>

- When connecting GP-H70 to 2 Port Adapter II (GP070-MD11) with GPH70-C422-O (3m) or GPH70-C422-MS (10m)

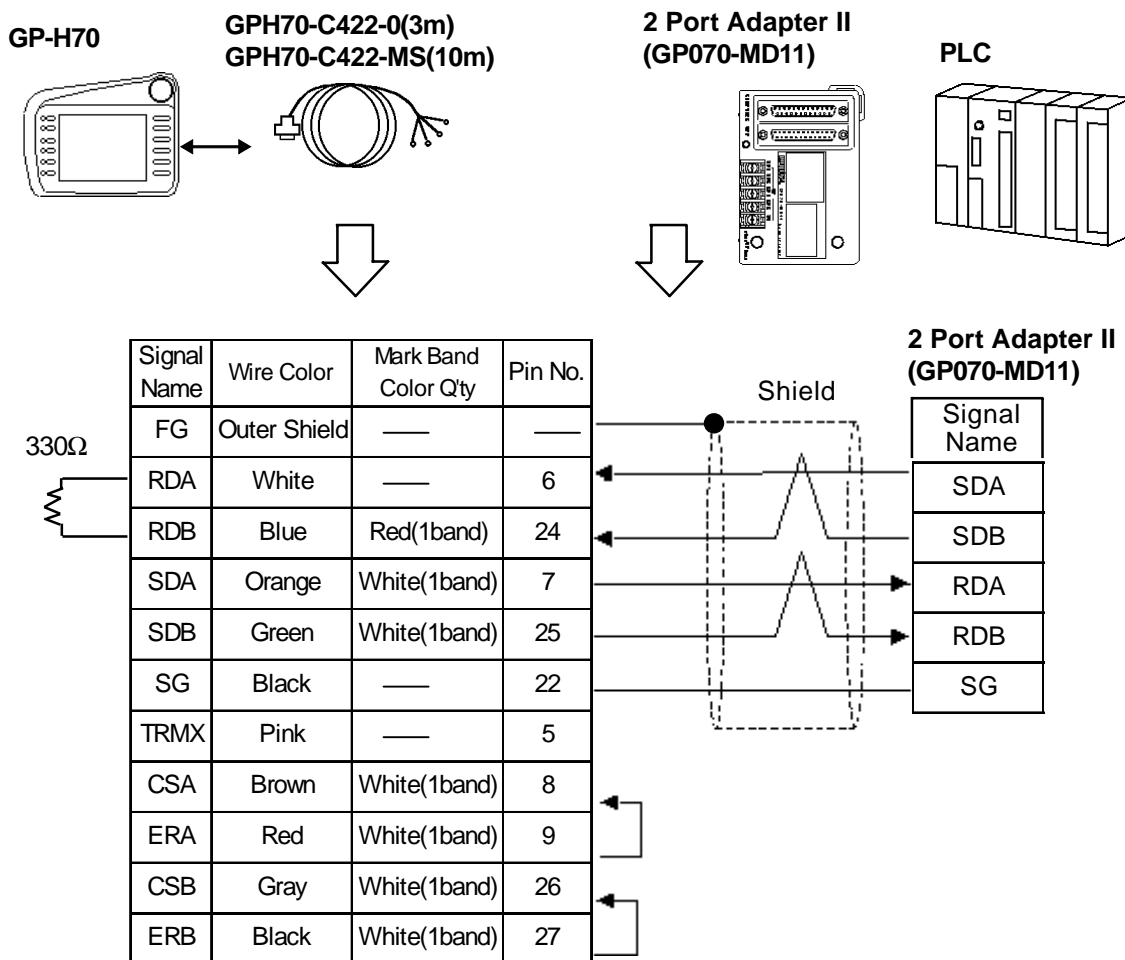

[GP-H70 series]

Pin numbers shown here represent the GP-H70 unit's connection pins.



- Instead of the TRMX pin, connect the 2 Port Adapter II's 330 Ω termination resistor to the RDB and RDA pins.
- GP-PRO/PBIII for Windows Ver.3.0 or highr required. (Protocol version should be V3.20 or higher.)
- Select "2PORT+GPH" via "Adapter Mode/ CPU Direct Mode" on GP's offline screen.
- Be sure the wires do not touch other signal wires or connector case when they are not used.

<Cable Diagram 5>

- When connecting GP-H70 to PLC with RS232C Conversion Adapter (GPH70-AP232-0) with GPH70-D232 (3m) or GPH70-D232-MS (10m)

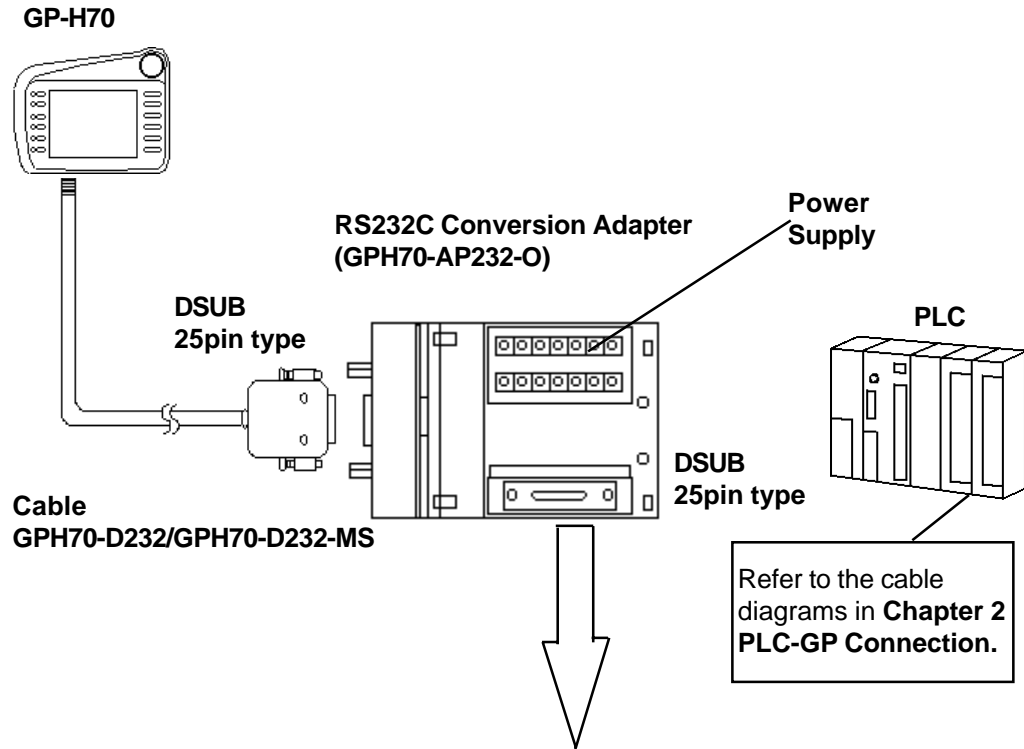

Dsub Connector

Pin No.	Signal Name
1	FG
2	SD
3	RD
4	RS
5	CS
7	SG
8	CD
14	+5V(out)
20	ER

14 point terminal block

Pin No.	Signal Name(Drawing Name)
1	DOUT0.C (DO0)
2	DOUT0.GND (D0G)
3	DOUT1.C (D01)
4	DOUT1.GND (D1G)
5	OP.C (OP)
6	OP.GND (OPG)
7	BUZZ OUT (BZ)
8	BUZZ GND (BZG)
9	EMG A (EMA)
10	EMG B (EMB)
11	+24V(in) (+24V)
12	0V (0V)
13	NC (NC)
14	FG (FG)

<Cable Diagram 6>

- When connecting GP-H70 to PLC via RS422 Conversion Adapter (GPH70-AP422-0) with GPH70-D422 (3m) or GPH70-D422-MS (10m)

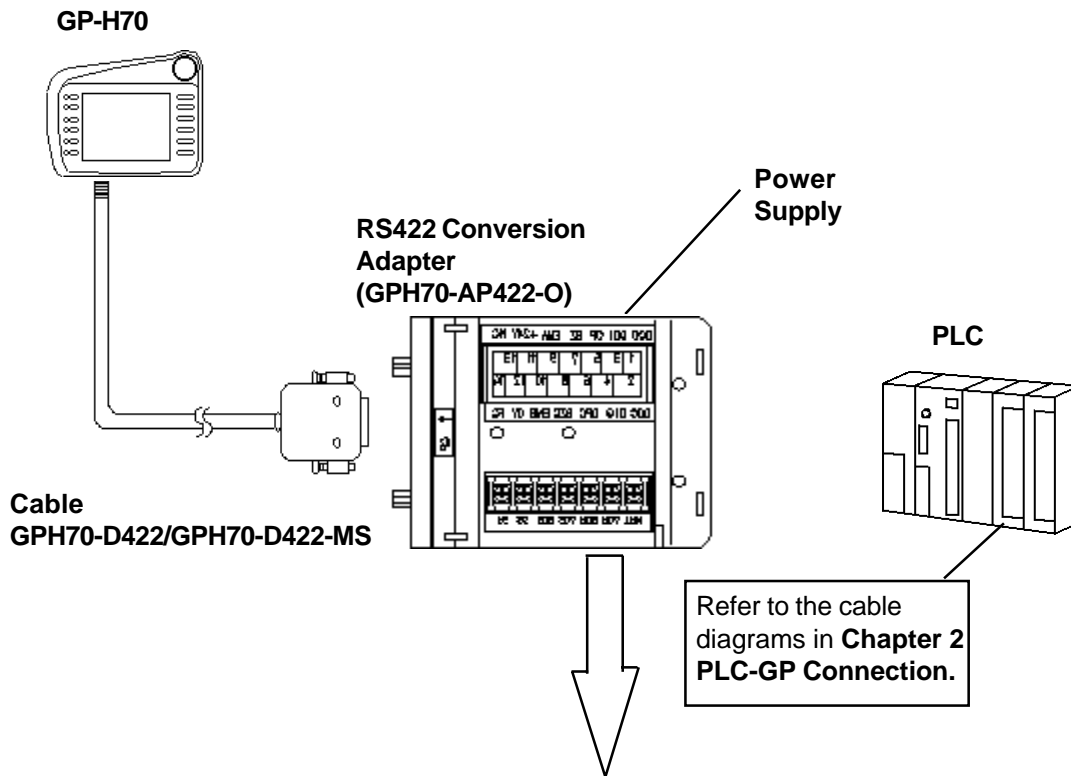

7 Point Terminal Block

Pin No.	Signal Name
1	FG
2	SG
3	SDB
4	SDA
5	RDB
6	RDA
7	TRMX(TRM) ^{*1}

**1 Connecting (shorting) the TRMX and RDA pins provides 100Ω of terminating between pins RDA and RDB.*

14 Point Terminal Block

Pin No.	Signal Name(Drawing Name)
1	DOUT0.C (D00)
2	DOUT0.GND (D0G)
3	DOUT1.C (D01)
4	DOUT1.GND (D1G)
5	OP.C (OP)
6	OP.GND (OPG)
7	BUZZ OUT (BZ)
8	BUZZ GND (BZG)
9	EMG A (EMA)
10	EMG B (EMB)
11	+24V(in) (+24V)
12	0V (0V)
13	NC (NC)
14	FG (FG)

<Cable Diagram 7>

- When connecting GP-H70 to PLC via RS422 Conversion Adapter (GPH70-AP422-0) and 2 Port Adapter II with GPH70-D422 (3m) or GPH70-D422-MS (10m)

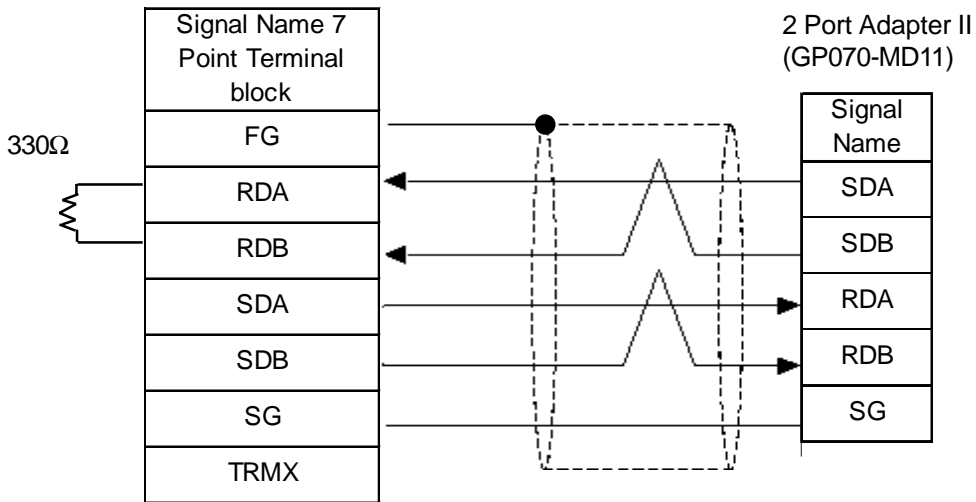
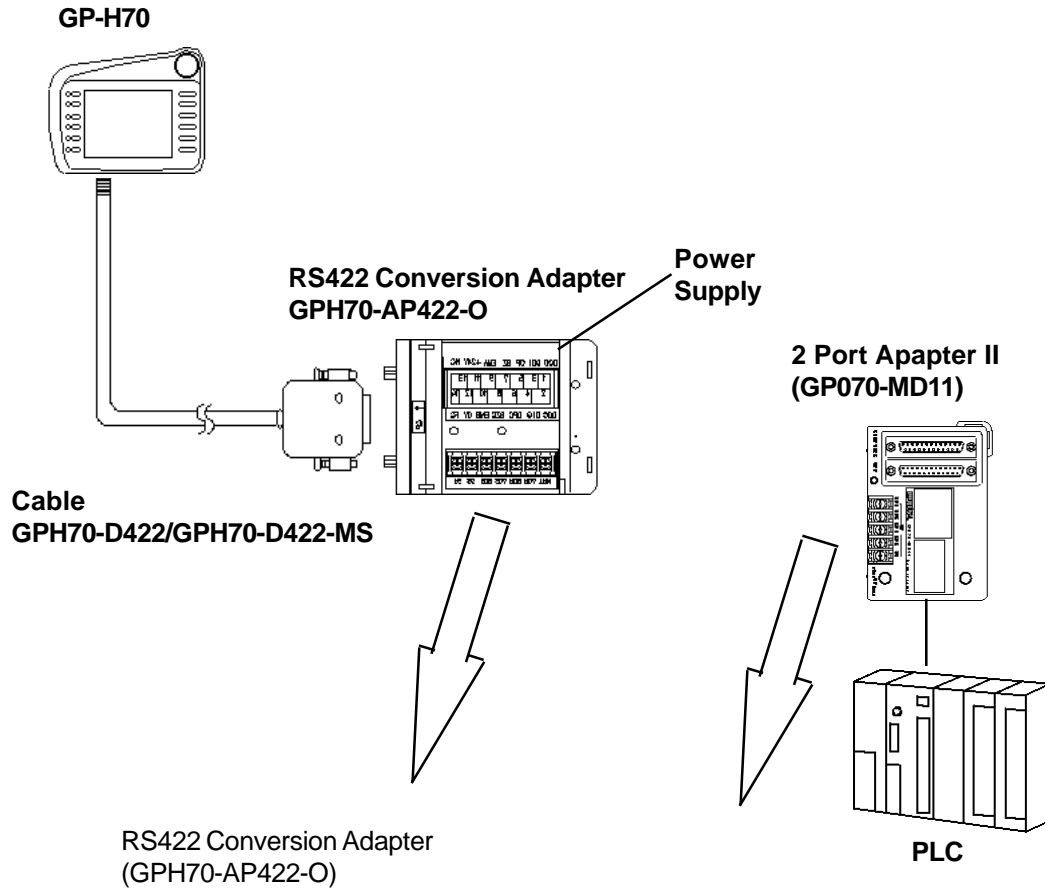

Note: Instead of the TRMX pin, connect the 2 Port Adapter II's 330Ω termination resistor to the RDB and RDA pins.

A1 Maximum Number of Consecutive PLC Addresses

The following lists the maximum number of consecutive addresses that can be read by each PLC. Refer to these tables to utilize *Block Transfer*.



Note: When the device is setup using the methods below, the Data Communication Speed declines by the number of times the device is read.

- When consecutive addresses exceed the maximum data number range
- When an address is designated for *division*
- When device types are different

To speed up data communication, plan the tag layout in screen units, as consecutive devices. (Includes the Alarm and Trend screens.)

A1.1 Maximum number of Consecutive PLC Addresses (by Maker)

■ Mitsubishi Electric Corporation

MELSEC-A Series

Device	Max. No. of Consecutive Address	Device	Max. No. of Consecutive Address
Input Relay X	32 Words	Data Register D	64 Words
Output Relay Y		Link Register W	
Internal Relay M		File Register R	
Latch Relay L		Extended File Register R	
Latch Relay B		Timer (current value) TN	
Timer (contact) TS		Counter (current value) CN	
Timer (coil) TC		/	
Counter (contact) CS			
Counter (coil) CC			

MELSEC-FX Series

Device	Max. No. of Consecutive Address
Input Relay X	32 Words
Output Relay Y	
Internal Relay M	
State S	
Timer (contact) TS	
Counter (contact) CC	
Data Register D	
Timer (current value) TN	
Counter (current value) CN	

MELSEC-F₂ Series

Device	Max. No. of Consecutive Address
Input Relay	8 Words
Output Relay	
Timer (contact)	
Counter (contact)	
Auxiliary Relay	
Keep Relay	
State	
Data Register W	
Timer (current value) TC	
Timer (setup value) TS	
Counter (current value) CC	
Counter (setup value) CS	

MELSEC-FX Series (using Link I/F)

Device	Max. No. of Consecutive Address
Input Relay	32 Words
Output Relay	
Auxiliary Relay	
State	
Special Auxiliary Relay	
Timer (contact)	
Counter (contact)	
Timer (current value)	64 Words
Counter (current value)	
Data Register	
Special Data Register	

MELSEC-QnA Series

Device	Max. No. of Consecutive Address	Device	Max. No. of Consecutive Address
Input Relay X	280 Words	Aggregate Timer (contact) SS	280 Words
Output Relay Y		Aggregate Timer (coil) SC	
Internal Relay M		Counter (contact) CS	
Special Relay SM		Counter (coil) CC	
Latch Relay L		Timer (current value) TN	
Annunciator F		Monostable Timer (current value) SW	
Edge Relay V		Counter (current value) CN	
Step Relay S		Data Register D	
Link Relay B		Special Register SD	
Special Link Relay SB		Link Register W	
Timer (contact) TS		Special Link Register SW	
Timer (contact) TC		File Register R	

* For direct CPU connections, use 480 words for all devices.

MELSEC-Q Series (CPU Direct Connection)

Device	Max. No. of Consecutive Address	Device	Max. No. of Consecutive Address
Input Relay	Total of 960 Words	Special Link Relay	Total of 960 Words
Output Relay		Timer (current value)	
Internal Relay		Aggregate Timer (current value)	
Special Relay		Counter (current value)	
Latch Relay		Data Register	
Annunciator		Special Data Register	
Edge Relay		Link Data Register	
Step Relay		Special Link Register	
Link Relay		File Register (normal)	
		File Register (serial) 0R-31R	

■ Omron

SYSMAC C Series (includes α Series) SYSMAC CV Series

Device	Max. No. of Consecutive Address
Input/Output Relay	19 Words
Internal Hold Relay	
Data Link Relay LR	10 Words
Latch Relay HR	
Auxiliary Memory Relay AR	28 Words
Timer (contact) TIM	48 Words
Counter (contact) CNT	
Data Memory DM	64 Words
Timer (current value) TIM	48 Words
Counter (current value) CNT	

Device	Max. No. of Consecutive Address
Input/Output Relay	19 Words
Internal Hold Relay	
SYSMAC BUS/2 Remote I/O Relay	
Data Link Relay	
Latch Relay	
SYSMAC Remote I/O Relay	28 Words
Special Auxiliary Relay A	
Timer (contact) T	48 Words
Counter (contact) C	
Data Memory D	64 Words
Timer (current value) T	48 Words
Counter (current value) C	

SYSMAC CS1 Series

Device	Max. No. of Consecutive Addresses
Channel I/O	255 Words
Internal Auxiliary Relay	
Hold Relay	
Special Auxiliary Relay	
Timer(Contact)	
Counter(Contact)	
Timer(Current)	
Counter(Current)	
Data Memory	
Exp. Data Memory (E0 to EX)	
Exp. Data Memory (Current Bank)	
Task Flag	16 Words
Index Register	32 Words
Data Register	16 Words

■ Fuji Electric
MICREX-F Series

Device	Max. No. of Consecutive Address	Device	Max. No. of Consecutive Address
Input/Output Relay B	48 Words	Timer 0.1 (current value) W9	24 Words
Auxiliary Relay M		Counter (current value) CR	
Keep Relay K		Counter (setup value) CS	
Differential Relay D		Data Memory BD	
Link Relay L		Data Memory DI	
Timer (0.01 sec) T	1 Word	Data Memory SI	48 Words
Timer (0.1 sec) T		File Memory (W30)	
Counter C		File Memory (W31)	
Direct Input/Output W	48 Words	File Memory (W32)	
Timer 0.01 (current value) TR	24 Words	File Memory (W33)	24 Words
Timer 0.01 (setup value) TS		File Memory (W34)	

FLEX-PC N Series

Device	Max. No. of Consecutive Address	Device	Max. No. of Consecutive Address
Input Relay X	105 Words	Data Register D	105 Words
Output Relay Y		Special Register D	
Internal Relay M		Link Register W	
Extended Internal Relay M		File Register R	
Latch Relay L		Timer (current value) T	
Extended Latch Relay L		Timer (setup value) TS	
Special Relay M		Counter (current value) C	
Timer T		Counter (setup value) CS	
Counter C			

■ Yaskawa Electric

Memocon-SC Series (includes Micro)

Device	Max. No. of Consecutive Address
Coil (Output/Internal)	250 Words
Input Relay	
Link Coil D	128 Words
Input Register	125 Words
Output/Latch Register	
Link Register R	
Constant Register	
Extended Register	

PROGIC-8 Series

Device	Max. No. of Consecutive Address
Output Coil O	250 Words
Input Relay I	
Internal Coil N	
Link Coil D	128 Words
Data Register W	125 Words
Input Register D	
Link Register R	

MP900/ CP-9200SH Series

Device	Max. No. of Consecutive Address
Output Coil	125 Words
Input Relay	
Special Latch Register	
Input Register	

Control Pack Series

Device	Max. No. of consecutive Address
Input Coil O	250 Words
Output Register	
System Register	
System Register	125 Words
Data Register	
Common Register	
Input Register	
Output Register	

GL130 Series

Device	Max. No. of Consecutive Address	Device	Max. No. of Consecutive Address
Coil	125 Words	Link Register 1. 2	125 Words
Input Relay		MC Relay	16 Words
Link Coil 1. 2		MC Coil	
Input Register		CM Code Relay 1. 2	
Output Register		MC Control Relay 1. 2	
Special Register		MC Control Coil 1. 2	

■ **Hitachi**

HIDIC-S10α Series

Device	Max. No. of Consecutive Address	Device	Max. No. of Consecutive Address
Input Relay X	256 Words	E Word EW	256 Words
Output Relay Y		On delay Timer (setup value) TS	
Internal Relay R		On delay Timer (calculated value) TC	
Global Link G		One shot Timer (setup value) US	
System Register S		One shot Timer (calculated value) UC	
Event E		Up/Down Counter (setup value) CS	
Keep Relay K		Up/Down Counter (calculated value) CC	
On delay Timer T		Word Register FW	
One-shot Timer U		Data Register DW	
Up/Down Counter C		Extended Register MS	

HIDIC H (HIZAC H) Series

Device	Max. No. of Consecutive Address	Device	Max. No. of Consecutive Address
External Input X	60 Words	Watch Dog Timer WD	60 Words
External Output Y		Monostable Timer MS	
Remote Input Relay X		Accumulation Timer TMR	
Remote Output Relay Y		Up Counter CU	
Internal Output R		Ring Counter RCU	
Level 1 CPU Link L		Up/Down Counter CT	
Level 2 CPU Link L		Word Internal Counter WR	
Data Area M		Timer/Counter elapsed value TC	
On delay Timer TD		Network Link Area WN	
Single Shot Timer SS			

HIZAC EC Series

Device		Max. No. of Consecutive Address	
		Address	Vertical Address
Bit Device	External Input X	16 Words	1 Word
	External Output Y		
	Internal Output M		---
	Timer, or Counter TC000 ~ TC095		
Word Device	External Input WX	8 Words	1 Word
	External Output WY		
	Internal Output WM		---
	Timer, or Counter TC100 ~ TC195 TC200 ~ TC295		

■ Sharp

New Satellite JW Series

Device	Max. No. of consecutive Address
Relay	100 Words
Timer (contact) T	
Counter (contact) C	
Timer/Counter (current value) T	
Timer/Counter (current value) B	
Register	
File Register (File 1~3) (File 10~2C)	

■ Matsushita Electric Works

MEWNET Series

Device	Max. No. of consecutive Address	Device	Max. No. of Consecutive Address
Input Relay X	27 Words	Link Register Ld	27 Words
Output Relay Y		Data Register /Special Data Register DT	
Internal Relay R		File Register FL	
Link Relay L		Timer/Counter (setup value) SV	24 Words
Special Relay R		Timer/Counter (elapsed value) SV	
Timer (contact) T	8 Words	/	
Counter (contact) C			

■ Yokogawa Electric

FACTORY ACE Series

Device	Max. No. of Consecutive Address	Device	Max. No. of Consecutive Address
Input Relay X	1 Words	Timer (current value) TP	63 Words
Output Relay Y		Timer (setup value) TS	
Internal Relay I	63 Words	Counter (current value) CP	
Joint Relay E		Counter (setup value) CS	
Timer (contact) T	16 Words	Data Register D	
Counter (contact) C		Common Register B ^{*1}	
Special Relay M	63 Words	File Register B ^{*1}	
Link Relay L		Special Register Z	
		Link Register W	

**1 Device B becomes the Common Register when the CPU is FA500, and becomes the File Register when the CPU is FA-M3.*

■ Toyota Machine Works

TOYOPUC-PC2 Series

Device	Max. No. of Consecutive Address	Device	Max. No. of Consecutive Address
Input Relay X	128 Words	Timer (contact) T	128 Words
Output Relay Y		Counter (contact) C	
Internal Relay I		Data Register D	
Keep Relay K		Link Register R	
Link Relay L		File Register B	
Edge Detect P		Current Value Register N	

TOYOPUC-PC3J Series

Device	Max. No. of Consecutive Addresses
Input(X)	128 Word
Output(Y)	
Internal Relay(M)	
Keep Relay(K)	
Link Relay(L)	
Special Relay(V)	
Edge Detection(P)	
Timer(T)	
Counter(C)	
Data Register(D)	
Link Register(R)	
Special Register(S)	
Current Value Register(N)	
File Register(B)	
Exp. Input(EX)	
Exp. Output(EY)	
Exp. Internal Relay(EM)	
Exp. Keep Relay(EK)	
Exp. Link Relay(EL)	
Exp. Special Relay(EV)	
Exp. Edge Relay(EP)	
Exp. Timer(ET)	
Exp. Counter(EC)	
Exp. Special Register (ES)	
Exp. Current Value Register(EN)	
Exp. Setting Value Register(H)	
Exp. Data Register(U)	

■ Toshiba

PROSEC EX Series

Device	Max. No. of Consecutive Address
External Input X	32 Words
External Output Y	
Auxiliary Relay R	
Link Register Relay Z	
Timer (contact) T	
Counter (contact) C	
Data Register D	
Timer (current value) T	
Counter (current value) C	

PROSEC T Series

Device	Max. No. of Consecutive Address
External Input 1 X	32 Words
External Output 1 Y	
External Input 2 I	
External Output 2 O	
Internal Relay R	
Special Relay S	
Link Register Relay Z	
Link Relay L	
Timer (contact) T	
Counter (contact) C	
Data Register D	
Link Register W	
File Register F	
Timer (current value) T	
Counter (current value) C	

■ Toshiba Machine

PROVISOR B Series, PROVISOR TC200 Series

Device	Max. No. of Consecutive Address	Device	Max. No. of Consecutive Address
Input Relay X	16 Words	Edge Relay E	16 Words
Output Relay Y		Timer (contact) T	
Internal Relay M		Counter (contact) C	
Extended Internal Relay 1 G		Generic Register 1	
Extended Internal Relay 2 H		Generic Register 2	
Special Auxiliary Relay A		Timer/Counter (current value)	
Latch Relay L		Timer/Counter (current value)	
Shift Register S			

■ Koyo Electronics Industries

KOSTAC SG Series

Device	Max. No. of Consecutive Address
Input Relay I	128 Words
Output Relay Q	
Internal Relay M	
Stage S	
Link Relay (input) GI	
Specified Transfer Relay (output) GQ	
Timer (contact) T	
Counter (contact) C	
Data Memory R	
Timer (elapsed value) R	
Counter (elapsed value) R	

KOSTAC SU Series

Device	Max. No. of Consecutive Address
Input Relay I	128 Words
Output Relay Q	
Internal Relay M	
Stage S	
Link Relay (input) GI	
Timer (contact) T	
Counter (contact) C	
Data Memory R	
Timer (elapsed value) R	
Counter (elapsed value) R	

KOSTAC SZ Series

Device	Max. No. of Consecutive Address
Input Relay I	128 Words
Output Relay Q	
Internal Relay M	
Timer (contact) T	
Counter (contact) C	
Data Memory R	
Stage S	
Timer (elapsed value) R	
Counter (elapsed value) R	

KOSTAC SR Series

Device	Max. No. of Consecutive Address
Input/Output	128 Words
Internal Relay	
Timer/Counter (contact) R	
Timer/Counter (elapsed value) R	
Variable Register R	

DL-405 Series

Device	Max. No. of Consecutive Address
Input Relay (X)	128 Words
Output Relay (Y)	
Internal Relay (C)	
Stage (S)	
Link Relay (GX)	
Timer (contact) (T)	
Counter (contact) (CT)	
Data Memory (V)	
Timer (elapsed value) (V)	
Counter (elapsed value) (V)	

DL-205 Series

Device	Max. No. of Consecutive Address
Input Relay (X)	128 Words
Output Relay (Y)	
Internal Relay (C)	
Timer (current) (T)	
Counter (current) (CT)	
Data Memory (V)	
Stage (S)	
Timer (elapsed value) (V)	
Counter (elapsed value) (V)	

DL-305 Series

Device	Max. No. of Consecutive Address
Input / Output	128 Words
Internal relay	
Timer / Counter (contact) (V)	
Timer / Counter (elapsed value) (V)	
Data Register (V)	

■ GE Fanuc Automation

SNP-X Protocol

Device	Max. No. of Consecutive Address
Input Relay I	128 Words
Output Relay Q	
Internal Relay M	
Global Relay G	
Momentary Relay T	
System Function Relay SA	
System Function Relay SB	
System Function Relay SC	
Register R	
Analog Input AI	
Analog Output AQ	

GE FANUC 90-30/90-70 SNP

Device	Max. No. of Consecutive Address
Input Relay I	250 Words
Output Relay Q	
Internal Relay M	
Global Relay G	
Temporary Relay T	
System Status Relay SA	
System Status Relay SB	
System Status Relay SC	
System Status Relay S	
Register R	
Analog Input AI	
Analog Input AQ	

■ Fanuc Motion Controller

FANUC Power Mate Series

Device	Max. No. of Consecutive Address
Input Relay X	128 Words
Output Relay Y	
Internal Relay	
Keep Relay K	
Data Table D	
Timer T	
Counter C	

■ IDEC Izumi

FA Series

Device	Max. No. of Consecutive Address
Input Relay XW	100 Words
Output Relay YW	
Internal Relay MW	
Shift Register RW	
Data Register D	
Control Register D	
Timer (setup value) TS	
Timer (current value) T	
Timer 10msec (current value) H	
Counter (setup value) CS	
Counter (current value) C	

MICRO³

Device	Max. No. of Consecutive Address
Input Relay X	2 Words
Output Relay Y	
Internal Relay M	13 Words
Shift Register R	4 Words
Timer (setup value) T	32 Words
Timer (calculated value) t	
Counter (setup value) C	
Counter (calculated value) c	
Data Register D	100 Words

MICROSmart FC4A Series/OpenNet Controller FC3 Series

Device	Max. No. of Consecutive Addresses
Input X	120 words
Output Y	
Internal Relay M	
Special Internal Relay M8	
Shift Register R	
Timer T	20 words
Timer t	
Counter C	
Counter c	
Data Register D	120 words
Special Data Register D8	
Link Register L	1 word

■ Siemens

SIMATIC S5 Series

Device	Max. No. of Consecutive Address
Input I	64 Words
Output Q	
Internal Relay F	
Timer T	
Counter C	
Data Word D	
Ext. Data Word X	

SIMATIC S7 300/400 (via MPI)

Device	Max. No. of Cosecutive Address
Input	64 Words
Output	
Internal	
Data Block	

SIMATIC S7 200 (via PPI)

Device	Max. No. of Cosecutive Address
Input	25 Words
Output	
Internal Memory	
Special Memory	
Variable Memory	
Timer Word	10 words
Counter Word	

SIMATIC S7 300/400 (via 3964/RK512)

Device	Max. No. of Cosecutive Address
Data Block	64 Words

SIMATIC 505 Series

Device	Max. No. of Consecutive Addresses
Variable Memory V	15 Words *1
Word Input WX	15 Words
Word Output WY	15 Words
Loop Gain LKC	7 Words
Loop Reset LTI	7 Words
Loop Rate LTD	7 Words
Loop Alarm High Limit LHA	7 Words
Loop Low Alarm Limit LLA	7 Words
Loop Process Variable LPV	7 Words
Loop PV High Limit LPVH	7 Words
Loop PV Low Limit LPVL	7 Words
Loop Orange Deviation Limit LODA	7 Words
Loop Yellow Deviation Alarm Limit LYDA	7 Words
Loop Sample Rate LTS	7 Words
Loop Setpoint LSP	7 Words
Loop Output LMN	7 Words
Loop Error LERR	7 Words
Loop Bias LMX	7 Words
Loop Alarm High-High Limit LHHA	7 Words
Loop Low-Low Alarm Unit LLLA	7 Words
Loop Rate of Change Alarm Limit LRCA	7 Words
Loop Setpoint High Point LSPH	7 Words
Loop Setpoint Low Limit LSPL	7 Words

Device	Max. No. of Consecutive Addresses
Loop Alarm Deadband LADB	7 Words
Loop V-flags LVF	7 Words
Most Significant Word of Loop C-flags LCFH	7 Words
Least Significant Word of Loop C-flags LCFL	7 Words
Analog Alarm/Alarm Acknowledge Flags AADB	7 Words
Most Significant Word of Analog Alarm C-flags ACFH	7 Words
Least Significant Word of Analog Alarm C-flags ACFL	7 Words
Analog Alarm Error AERR	7 Words
Analog Alarm High Alarm Limit AHA	7 Words
Analog Alarm High-High Alarm Limit AHHA	7 Words
Analog Alarm Low Alarm Limit ALA	7 Words
Analog Alarm Low-Low Alarm Limit ALLA	7 Words
Analog Alarm Loop Orange Deviation Alarm Limit AODA	7 Words
Analog Alarm Process Variable APV	7 Words
Analog Alarm Rate of Change Alarm Limit ARCA	7 Words
Analog Alarm Setpoint ASP	7 Words
Analog Alarm SP High Limit ASPH	7 Words
Analog Alarm SP Low Limit ASPL	7 Words
Analog Alarm Sample Rate ATS	7 Words
Analog Alarm Yellow Deviation Alarm Limit AYDA	7 Words
Timer/Counter Preset TCP	7 Words
Timer/Counter Current TCC	7 Words
Drum Counter Preset DCP	7 Words
Drum Step Preset DSP	10 Words
Drum Step Current DSC	10 Words
Status Word STW	7 Words
Drum Count Current DCC	10 Words

*1 For device address V1024 or higher, use 7 words.

■ Rockwell (Allen-Bradley)

AB SLC 500 Series

Device	Max. No. of Consecutive Address
Bit B	118 Words
Timer TP/TA	
Counter CP/CA	
Timer TT/TN	
Counter CU/CD/CN	
Integral Number N	

AB PLC-5 Series

Device	Max. No. of Consecutive Address
Input Relay I	64 Words
Output Relay O	
Internal Relay B	
Data Register N/D/A	
Timer TP/TA	40 Words
Counter CP/CA	
Timer TT/TN	
Counter CU/CD	

AB SLC 500 DH485

Device	Max. No. of Consecutive Address
Status	40 Words
Bit	
Timer	
Counter	
Control	
Integer	

AB DH Plus

Device	Max. No. of Consecutive Address
Output	50 Words
Input	
Status	
Bit	
Timer	
Counter	
Control	
Integer	
Float	
Ascii	

■ **Keyence**

KZ-300/KZ-350 Series

Device	Max. No. of Consecutive Address
Input Relay	19 Words
Output Relay	
Auxiliary Relay	
Internal Hold Relay	
Special Auxiliary Relay	
Timer T	48 Words
Counter C	
Data Memory DM	64 Words
Temporary Data Memory TM	10 Words

KZ-A500 Series

Device	Max. No. of Consecutive Addresses
Input Relay (X)	32 Words
Output Relay (Y)	
Internal Relay (M)	
Latch Relay (L)	
Link Relay (B)	
Annunciator Relay (F)	
Special Relay (M9)	
Timer (contact) TS	16 Words
Timer (coil) TC	
Counter (contact) CS	
Counter (coil) CC	
Timer(current value) TN	64 Words
Counter (current value) CN	
Data Register (D)	
Link Register (W)	
File Register (R)	
Special Register (D9)	

■ Shinko Electric

SELMART Series

Device	Max. No. of Consecutive Address
Data Register	64 Words

■ Modicon

Modicon Modbus Master

Device	Max. No. of Consecutive Address
Output Bit	80 Words
Input Bit	
Output Register	
Input Register	

Modicon Modbus Plus

Device	Max. No. of Consecutive Address
Output Bit	80 Words
Input Bit	
Output Register	
Input Register	

Modicon Modbus Slave

Device	Max. No. of Consecutive Address
Output Register	125 Words

■ Matsushita Electric Industrial

Panadac P7000 series

Device	Max. No. of Consecutive Address	Device	Max. No. of Consecutive Address
Input Relay	58 Words	Link Register	58 Words
Internal Relay		Timer (setup value)	
Link Relay		Counter (current value)	
Status Relay		Counter Value	29 Words
MC Status Relay		Position Data	58 Words
Timer State Relay		CPU Input Relay	
Timer-up Relay		CPU Output Relay	
Data Memory			

■ ORIM VEXTA

E1 Series

Device	Max. No. of Consecutive Addresses
I	64 Words
IU	
ID	
O	
M	
R	
RD	
B	
MS	
SY	
AD	
DA	
SL	
SH	
SR	
SD	
MP	

■ FATEK

Facon FB 20MC (using CPU Direct Connection)

Device	Max. No. of Consecutive Addresses
X (Input points)	1 Words
Y (Output Relays)	
M (Internal Relays)	
SM (Special Relays)	
S (Step Relays)	
T (Timer Registers)	
C (Counter Registers)	
WX (Input points)	32 Words
WY (Output Relays)	
WM (Internal Relays)	
WSM (Special Relays)	
WS (Step Relays)	
TMR (Timer Registers)	
CTR (Counter Registers)	
HR (Data Register)	
IR (Input Registers)	
OR (Output Registers)	
HSC (HSC Registers)	
RTC (Calendar Registers)	
SR (Special Register)	
ROR (Read-Only Registers)	

Using Ethernet Connection

■ Mitsubishi Electric

MELSEC-A Series

Device	Max. No. of Consecutive Address
Input Relay	128 Words
Output Relay	
Latch Relay	
Special Relay	
Annunciator	
Link Relay	
Timer (contact)	
Timer (coil)	
Counter (contact)	
Counter (coil)	
Timer (current value)	
Counter (current value)	
Data Register	
Special Register	
Link Register	
File Register	

MELSEC-Q/QnA Series

Device	Max. No. of Consecutive Address
Input Relay	480 Words
Output Relay	
Internal Relay	
Special Relay	
Latch Relay	
Annunciator	
Edge Relay	
Step Relay	
Link Relay	
Special Link Relay	
Timer (Current Value)	
Aggregate Timer (Current Value)	
Counter (Current Value)	
Data Register	
Special Register	
Link Register	
Special Link Register	
File Register (Normal)	
File Register (Serial) 0R ~ 31R	

■ **Toshiba**

PROSEC-T Series

Device	Max. No. of Consecutive Addresses
External Input Device	248 bits
External Output Device	
Auxiliary Relay	
Special Relay	
Link Register Relay	
Link Relay	
Timer (Contact)	
Counter (Contact)	
Timer (Current Value)	
Counter (Current Value)	
Data Register	
Link Register	
File Register	

■ **Yokogawa Electric**

FACTORY ACE Series/FA-M3

Device	Max.No.of Consecutive Addresses
Input Relay	1 Word
Output Relay	
Internal Relay	64 words
Common Relay	
Special Relay	
Link Relay	
Timer (contact)	16 words
Counter (contact)	
Timer (current value)	64words
Counter (current value)	
Timer (setup value)	
Counter (setup value)	
Data Register	
File Register	
Common Register	
Special Register	
Link Register	

■ **OMRON**

SYSMAC CS1 Series

Device	Max.No.of Consecutive Addresses
Channel I/O	400 words
Internal Auxiliary Relay	
Latch Relay	
Special Auxiliary Relay	
Timer (Contact)	
Counter (Contact)	
Timer (Current Value)	
Counter (Current Value)	
Data Memory	
Extended Data Memory (E0 ~ EC)	
Extended Data Memory (Current Bank)	
Task Flag	16 words
Index Register	32 words
Data Register	16 words

Interbus-S connection

■ Siemens

Packet Transfer Mode

Device	Max. No. of Consecutive Address
Data Block DBxW	6 Words
Input IW	
Output OW	
Internal Memory MW	

Using CC-Link Intelligent Device Station

■ Mitsubishi Electric

MELSEC-A/QnA/Q Series

Device	Max. No. of Consecutive Address
Input Relay	480 Words
Output Relay	
Internal Relay	
Special Relay	
Latch Relay	
Special Link Relay	
Timer (contact)	
Timer (coil)	
Aggregate Timer (contact)	
Aggregate Timer (coil)	
Counter (contact)	
Counter (coil)	
Timer (current value)	
Aggregate Timer (current value)	
Counter (current value)	
Data Register	
Special Register	
Link Register	
Special Link Register	
File Register	

Using Electronic Temperature Controller

■ Yokogawa/Yokogawa M&C Controllers

Device	Max. No. of Consecutive Addresses
D	63 Words
I	63 Words

■ Yamatake Controllers

Device	Max. No. of Consecutive Addresses
Data	5 Words

■ RKC INSTRUMENT INC. Controllers

Device	Max. No. of Consecutive Addresses
_____	125 Words

■ Omron Corporation Controllers

Device	Max. No. of Consecutive Addresses
C0	2 Double Words
C1	
C3	
A	1 Word

■ RKC INSTRUMENT INC.

CB Series/SR-MiniSeries

Device	Max.No.of Consecutive Addresses
Dataltems	1 Word

■ Shinko Technos Corporation Controllers

C/FC/FIR/GC/FCL/PC-900 Series

Device	Max.No.of Consecutive Addresses
Dataltems	1 Word
Setting Value Memory 1 to 7	1 Word
Channel 1 to 20	1 Word *1

**1 Although only a single word can be read at a time from a single controller, up to 20 channels can be read simulataneously.*

**■ Fuji Electric Corporation Controller
Micro-Controller X Series (Model:PXR)**

Device Address	Max. No. of Consecutive Address
00001 ~	1 bit
10001 ~	8 bit
30001 ~	15 words
40001 ~	60 words
31001 ~	15 words
41001 ~	60 words

■ TOHO ELECTORICS INC.

TTM Series

Device	Max. No. of Consecutive Addresses
00_	1 word
10_	
100_	
110_	
120_	
300_	
1020_	
Step Temperature Setting SSV	
Final Step Setting END	
Step time Setting STI	
Final Step Finish Condition Setting SOK	
Step Wait Zone SWZ	
Step Wait Time SWT	
Time Signal ON Time SON	
Time Signal OFF Time SOF	
Execution Time SRN	
End Signal ON Time SEO	

Using Inverter

■ Mitsubishi Electric

Device	Max. No. of Consecutive Address
————	1 Words
P	1 Double Words
OPE	1 Words
OUTF	1 Double Words
OUTC	1 Words
OUTV	
SPM	
SSEL	
SOF	
SOC	
SOV	
FSET	
RUNS	
MOT	
RBRK	
ELOF	
OCPV	
COPK	
IPOW	
OPOW	
A12D	
A34D	
A56D	
A78D	
RUNC	
INVS	
RWRT	
SFWE	
SFWR	
SFRE	
SFRR	
ERCL	
RSET	
ALLC	
LNKP	
SECP	

■ Fuji Electric

Device	Max. No. of consecutive Address
Basic Function	1 Word
Terminal Function	
Control Function	
Motor 1	
High Level Function	
Motor 2	
Option	
Order Data	
Monitor Data	

A 2**Device Codes and Address Codes**

Device codes and address codes are used to specify indirect addresses for the E-tags or K-tags.

The word addresses of data to be displayed are coded and stored in the word address specified by the E-tags and K-tags. (Code storage is done either by the PLC, or with T-tag and K-tags)

Example: MELSEC-A Series (Mitsubishi Electric Corp.)

When the GP-PRO/PBIII for Windows software has been used to set on E-tag's "Word Address" to "D0000", to display the M0016 interval relay's data on the GP, store the following code data:

D0000	9000	<- Device code
D0001	0001	<- Address code

The device code for the M0016 internal relay is "9000" and the address code is "0001" (0016/16).

A 2.1 PLC Devices and Address Codes (by Maker)

The codes used for each type of PLC are shown below. [LS Area] is the device inside the GP.

Codes marked with an X cannot be used to specify E-tag and K-tag indirect addresses.

■ Mitsubishi

MELSEC-A Series (AnA/AnU/A2US/A2USH-S1)

	Device	Word Address	Device code (HEX)	Address code
Bit Device	Input Relay	X0000~	8000	Save as word address value, with the tenths position "0" removed.
	Output Relay	Y0000~	8800	Save as word address value, with the tenths position "0" removed.
	Internal Relay	M0000~	9000	Save as word address value divided by 16.
	Special Relay	M9000~	B000	Save as word address value minus 9000 divided by 16.
	Annunciator	F0000~	B800	Save as word address value divided by 16.
Word Device	Timer (current value)	TN0000~	6000	Word Address
	Counter (current value)	CN0000~	7000	Word Address
	Data Register	D0000~	0000	Word Address
	Special Register	D9000~	0000	Word Address
	Link Register	W0000~	4800	Word Address
	File Register	R0000~	5800	Word Address
	LS area	LS0000~	4000	Word Address

MELSEC-A Series (AnN/A2C/A1S/A3H/A0J2/A1SJ/A2SH/A1SH/A2CJ-S3)

	Device	Word Address	Device code (HEX)	Address code
Bit Device	Input Relay	X0000~	8000	Save as word address value, with the tenths position "0" removed.
	Output Relay	Y0000~	8800	Save as word address value, with the tenths position "0" removed.
	Internal Relay	M0000~	9000	Save as word address value divided by 16.
	Special Relay	M9000~	B000	Save as word address value minus 9000 divided by 16.
	Annunciator	F000~	B800	Save as word address value divided by 16.
Word Device	Timer (current value)	TN000~	6000	Word Address
	Counter (current value)	CN000~	7000	Word Address
	Data Register	D0000~	0000	Word Address
	Link Register	W0000~	4800	Word Address
	File Register	R0000~	5800	Word Address
	LS area	LS0000~	4000	Word Address

MELSEC-F₂ Series

	Device	Word Address	Device code (HEX)	Address code
Word Device	Timer (current value)	TC050~ TC450~ TC550~ TC650~	X	X
	Timer (set value)	TS050~ TS450~ TS550~ TS650~	X	X
	Counter (current value)	CC060~ CC460~ CC560~ CC660~	X	X
	Counter (set value)	CS060~ CS460~ CS560~ CS660~	X	X
	Data Register	DW700 ~	0000	Save as word address value minus 700.
	LS area	LS0000 ~	4000	Word Address

MELSEC-FX Series (FX₀)

	Device	Word Address	Device code (HEX)	Address code
Bit Device	Input Relay	X000~	8000	Word Address
	Output Relay	Y000~	8800	Word Address
	Internal Relay	M000~	9000	Save as word address value divided by 16.
	State	S000~	9800	Save as word address value divided by 16.
Word Device	Timer (current value)	TN000~	6000	Word Address
	Counter (current value)	CN000~	7000	Word Address
	Data Register	D000~	0000	Word Address
	LS area	LS0000~	4000	Word Address

MELSEC-FX Series (FX₁/FX₂/FX_{2N}/FX_{0N})

	Device	Word Address	Device code (HEX)	Address code
Bit Device	Input Relay	X000~	8000	Save as word address value, with the tenths position "0" removed.
	Output Relay	Y000~	8800	Save as word address value, with the tenths position "0" removed.
	Internal Relay	M0000~	9000	Save as word address value divided by 16.
	State	S000~	9800	Save as word address value divided by 16.
Word Device	Timer (current value)	TN000~	6000	Word Address
	Counter (current value)	CN000~	7000	Word Address
	Data Register	D000~	0000	Word Address
	LS area	LS0000~	4000	Word Address

MELSEC-QnA Series

	Device	Word Address	Device code (HEX)	Address code
Bit Device	Input Relay	X0000~	8000	Save as word address value, with the tenths position "0" removed.
	Output Relay	Y0000~	8800	Save as word address value, with the tenths position "0" removed.
	Internal Relay	M00000~	9000	Save as word address value divided by 16.
	Special Relay	SM0000~	B000	Save as word address value divided by 16.
	Latch Relay	L00000~	C 000	Save as word address value divided by 16.
	Annunciator	F00000~	B800	Save as word address value divided by 16.
	Edge Relay	V0000~	9800	Save as word address value divided by 16.
	Step Relay	S0000~	A800	Save as word address value divided by 16.
	Link Relay	B0000~	C 800	Save as word address value, with the tenths position "0" removed.
Special Link Relay	SB000~	A000	Save as word address value, with the tenths position "0" removed.	
Word Device	Timer (current value)	TN00000~	6000	Word Address
	Aggregate Timer (current value)	SN00000~	5000	Word Address
	Counter (current value)	CN00000~	7000	Word Address
	Data Register	D0000~	0000	Word Address
	Special Register	SD0000~	6800	Word Address
	Link Register	W0000~	4800	Word Address
	Special Link Register	SW000~	7800	Word Address
	File Register (normal)	R00000~	5800	Word Address
	File Register (serial)	0R0000~	0600	Word Address
		1R0000~	0800	Word Address
LS area	LS0000~	4000	Word Address	

MELSEC-Q Series

	Device	Word Address	Device code (HEX)	Address code
Bit Device	Input Relay	X0000 ~	8000	Save as word address value, with the tenths position "0" removed.
	Output Relay	Y0000 ~	8800	Save as word address value, with the tenths position "0" removed.
	Internal Relay	M0000 ~	9000	Save as word address value divided by 16.
	Special Relay	SM0000 ~	B000	Save as word address value divided by 16.
	Latch Relay	L0000 ~	C000	Save as word address value divided by 16.
	Annunciator	F0000 ~	B800	Save as word address value divided by 16.
	Edge Relay	V0000 ~	9800	Save as word address value divided by 16.
	Step Relay	S0000 ~	A800	Save as word address value divided by 16.
	Link Relay	B0000 ~	C800	Save as word address value, with the tenths position "0" removed.
Special Link Relay	SB000 ~	A000	Save as word address value, with the tenths position "0" removed.	
Word Device	Timer (current value)	TN00000 ~	6000	Word Address
	Aggregate Timer (Current value)	SN00000 ~	5000	Word Address
	Counter (current value)	CN00000 ~	7000	Word Address
	Data Register	D00000 ~	0000	Word Address
	Special Data Register	SD0000 ~	6800	Word Address
	Link Data Register	W0000 ~	4800	Word Address
	Special Link Register	SW000 ~	7800	Word Address
	File Register (normal)	R0000 ~	5800	Word Address
	File Register (serial)	0R0000 ~	0600	Word Address
		1R0000 ~	0800	Word Address
		2R0000 ~	0A00	Word Address
		3R0000 ~	0C00	Word Address
		4R0000 ~	0E00	Word Address
		:	:	:
29R0000 ~		4200	Word Address	
30R0000 ~		4400	Word Address	
31R0000 ~	4600	Word Address		

■ Omron

SYSMAC C Series

	Device	Word Address	Device code (HEX)	Address code
Bit Device	Input Relay	000~	9100	Word Address
	Internal Auxiliary Relay			
	Analog Setup Value Storage Area	220~	9100	Word Address
	Data Link Relay	LR00~	C 900	Word Address
	Special Auxiliary Relay	244~	9100	Word Address
	Auxiliary Memory Relay	AR00~	B000	Word Address
	Latch Relay	HR00~	C 100	Word Address
Word Device	Timer (current value)	TIM0000~	6000	Word Address
	Counter (current value)	CNT0000~	7000	Word Address
	Data Register	DM0000~	0000	Word Address
	LS area	LS0000~	4000	Word Address

SYSMAC α Series

	Device	Word Address	Device code (HEX)	Address code
Bit Device	I/O Relay I	000~	9100	Word Address
	I/O Relay II	300~	9100	Word Address
	Internal Auxiliary Relay I	030~	9100	Word Address
	Internal Auxiliary Relay II	310~	9100	Word Address
	Special Auxiliary Relay I	236~	9100	Word Address
	Special Auxiliary Relay II	256~	9100	Word Address
	Latch Relay	HR00~	C 100	Word Address
	Auxiliary Memory Relay	AR00~	B000	Word Address
	Link Relay	LR00~	C 900	Word Address
Word Device	Timer (current value)	TIM000~	6000	Word Address
	Counter (current value)	CNT000~	7000	Word Address
	Data Memory	DM0000~	0000	Word Address
	LS area	LS0000~	4000	Word Address

SYSMAC CV Series

	Device	Word Address	Device code (HEX)	Address code
Bit Device	Input Relay	000~	9100	Word Address
	Internal Auxiliary Relay			Word Address
	SYSMAC BUS/2 Remote I/O Relay	0200~	9100	Word Address
	Data Link Relay	1000~	9100	Word Address
	Special Auxiliary Relay	A000~	B000	Word Address
	Latch Relay	1200~	9100	Word Address
	Internal Auxiliary Relay	1900~	9100	Word Address
	SYSMAC BUS/2 Remote I/O Relay	2300~	9100	Word Address
Word Device	Timer (current value)	T0000~	6000	Word Address
	Counter (current value)	C 0000~	7000	Word Address
	Data Memory	D0000~	0000	Word Address
	LS area	LS0000~	4000	Word Address

SYSMAC CS1 Series

Device	Word Address	Device Address	Particulars
Channel I/O	CIO000000 -	CIO9000	Word Address
Internal Auxiliary Relay	W00000 -	8200	Word Address
Hold Relay	H00000 -	C000	Word Address
Special Auxiliary Relay	A00000 -	B000	Word Address
Timer(Current)	T0000 -	6000	Word Address
Counter(Current)	C0000 -	7000	Word Address
Data Memory	D0000 -	0000	Word Address
Exp. Data Memory (E0 to EC)	E000000 -	9200	Word Address
	E100000 -	9400	Word Address
	E200000 -	9600	Word Address
	E300000 -	9800	Word Address
	E400000 -	9A00	Word Address
	E500000 -	9C00	Word Address
	E600000 -	9E00	Word Address
	E700000 -	A000	Word Address
	E800000 -	A200	Word Address
	E900000 -	A400	Word Address
	EA00000 -	A600	Word Address
	EB00000 -	A800	Word Address
EC00000 -	AA00	Word Address	
Exp. Data Memory (Current Bank)	EM000000 -	1000	Word Address
Task Flag	TK0 -	5000	Save as word address value divided by 2.
Index Register	IR0 -	2000	Word Address
Data Register	DR0 -	3000	Word Address
LS area	LS0000 -	4000	Word Address

CS1 Series (Ethernet Communication)

E-tag or K-tag indirect addresses cannot be designated by a SYSMAC CS1 Series unit on an Ethernet network.

■ Fuji Electric
MICREX-F Series

	Device	Word Address	Device code (HEX)	Address code
Bit Device	Input Relay	WB0000~	8040	Word Address
	Direct I/O	W24.0000~	4840	Word Address
	Auxiliary Relay	WM0000~	9040	Word Address
	Keep Relay	WK000~	C040	Word Address
	Differential Relay	WD000~	D040	Word Address
	Link Relay	WL000~	C840	Word Address
	Special Relay	WF0000~	B040	Word Address
	Announce Relay	WA0000~	B840	Word Address
Word Device	Timer 0.01 sec (current value)	TR0000~	6080	Word Address
	Timer 0.01 sec (set value)	TS0000~	6880	Word Address
	Timer 0.1 sec (current value)	W9.000~	6480	Word Address
	Counter (current value)	CR0000~	7080	Word Address
	Counter (set value)	CS0000~	7880	Word Address
	Data Memory	BD0000~	0080	Word Address
		DI0000~	0880	Word Address
		SI0000~	0440	Word Address
	File Memory	W30.0000~	2040	Word Address
		W31.0000~	2240	Word Address
		W32.0000~	2440	Word Address
		W33.0000~	2680	Word Address
		W34.0000~	2880	Word Address
LS area	LS0000~	4040	Word Address	

FLEX-PC Series

	Device	Word Address	Device code (HEX)	Address code
Bit Device	Input Relay	WX000~	8040	Word Address
	Output Relay	WY000~	8840	Word Address
	Internal Relay	WM000~	9040	Word Address
	Extended Internal Relay	WM040~	9840	Word Address
	Latch Relay	WL000~	C040	Word Address
	Extended Latch Relay	WL040~	C840	Word Address
	Special Relay	WM800~	X	X
Word Device	Timer (current value)	T0000~	6000	Word Address
	Timer (set value)	TS0000~	6800	Word Address
	Counter (current value)	C0000~	7000	Word Address
	Counter (set value)	CS0000~	7800	Word Address
	Data Register	D0000~	0040	Word Address
	Special Register	D8000~	X	X
	Link Register	W0000~	0440	Word Address
	File Register	R0000~	4840	Word Address
	LS area	LS0000~	4040	Word Address

■ **Yaskawa Electric**

Memocon-SC Series (U84/84J/U84S/GL40S/GL60H/GL70H/GL60S)

	Device	Word Address	Device code (HEX)	Address code
Word Device	Input Register	30001~	1240	Save as word address value minus 30001.
	Output/Keep Register	40001~	0040	Save as word address value minus 40001.
	Link Register	R0001~	4840	Save as word address value minus 1.
	Constant Register	31001~	1440	Save as word address value minus 31001.
	Extended Register	A0000~	1040	Word Address
	LS area	LS0000~	4040	Word Address

Memocon-SC Series (GL120/GL130)

	Device	Word Address	Device code (HEX)	Address code
Word Device	Input Register	300001~	1240	Save as word address value minus 30001.
	Output Register	400001~	0040	Save as word address value minus 40001.
	Keep Register	400513~	0040	Save as word address value minus 40001.
	Constant Register	700001~	X	X
	LS area	LS0000~	4040	Word Address

PROGIC-8 Series

	Device	Word Address	Device code (HEX)	Address code
Word Device	Data Register	W1~	0040	Save as word address value minus 1.
	Input Register	Z1~	1240	Save as word address value minus 1.
	Link Register	R1~	4840	Save as word address value minus 1.
	LS area	LS0000~	4040	Word Address

Control Pack Series/MP900 Series

	Device	Word Address	Device code (HEX)	Address code
Word Device	Input Register	49744~	0040	Save as word address value minus 40001.
	Output Register	49872~	0040	Save as word address value minus 40001.
	System Register	30001~	1240	Save as word address value minus 30001.
	Data Register	31001~ (CP-9200H only)	1440	Save as word address value minus 3101.
		40001~	0040	Save as word address value minus 40001.
	Common Register	42049~	0040	Save as word address value minus 40001.
LS area	LS0000~	4040	Word Address	

Memocon Micro

	Device	Word Address	Device code (HEX)	Address code
Word Device	Input Register	30001~	1240	Save as word address value minus 30001.
	Output/Keep Register	40001~	0040	Save as word address value minus 40001.
	LS area	LS0000~	4040	Word Address

■ Hitachi

HIDIC S10 α Series

	Device	Word Address	Device code (HEX)	Address code
Bit Device	Input Relay	XW000~	8040	Save as word address value, with the tenths position "0" removed.
	Output Relay	YW000~	8840	Save as word address value, with the tenths position "0" removed.
	Internal Relay	RW000~	9040	Save as word address value, with the tenths position "0" removed.
	Global Link	GW000~	C840	Save as word address value, with the tenths position "0" removed.
	System Register	SW000~	B040	Save as word address value, with the tenths position "0" removed.
	E Word	EW400~	X	X
	Event	EW000~	A040	Save as word address value, with the tenths position "0" removed.
	Keep Relay	K0000~	C040	Save as word address value, with the tenths position "0" removed.
	On-Delay Timer	TW000~	E040	Save as word address value, with the tenths position "0" removed.
	One Shot Timer	UW000~	E240	Save as word address value, with the tenths position "0" removed.
	Up/Down Counter	CW000~	F040	Save as word address value, with the tenths position "0" removed.
Word Device	On-Delay Timer (Calculated value)	TC000~	6000	Word Address
	On-Delay Timer (setup value)	TS000~	6800	Word Address
	One Shot Timer (Calculated value)	UC000~	6200	Word Address
	One Shot Timer (setup value)	US000~	6A00	Word Address
	Up/Down Counter (Calculated value)	CC000~	7000	Word Address
	Up/Down Counter (setup value)	CS000~	7800	Word Address
	Data Register	DW000~	0040	Word Address
	Word Register	FW000~	0840	Word Address
	Extended Register	MS000~	3040	Word Address
	LS area	LS0000~	4040	Word Address

HIDIC H (HIZAC H) Series

	Device	Word Address	Device code (HEX)	Address code
Bit Device	External Input	WX0000~	X	X
	External Output	WY0000~	X	X
	Remote Input Relay	WX1000~	X	X
	Remote Output Relay	WY1000~	X	X
	CPU Link Area 1	WL000~	C 800	Word Address
	CPU Link Area 2	WL1000~	C 800	Word Address
	Data Area	WM000~	9000	Word Address
Word Device	Timer/Counter (elapsed value)	TC000~	6000	Word Address
	Word Internal Output	WR0000~	0000	Word Address
	Network Link Area	WN0000~	5000	Word Address
	LS area	LS0000~	4000	Word Address

HIZAC EC Series

	Device	Word Address	Device code (HEX)	Address code
Bit Device	External Input	WX000-	8240	Word Address
		WX020-		
		WX040-		
		WX060-		
		WX080-		
		WX100-		
		WX120-		
		WX140-		
		WX160-		
		WX180-		
	External Output	WY 200-	8A40	Save as word address value minus 200.
		WY 220-		
		WY 240-		
		WY 260-		
		WY 280-		
WY 300-				
WY 320-				
WY 340-				
WY 360-				
WY 380-				
Internal Output	WM 400-	9240	Save as word address value minus 400 divided by 2.	
	WM 700-	9240	Save as word address value minus 400 divided by 2.	
	WM 960-	9240	Save as word address value minus 400 divided by 2.	
Word Device	Timer/Counter (elapsed value)	TC 100-	6000	Save as word address value minus 100.
	Timer/Counter (set value)	TC 200-	6400	Save as word address value minus 200.
	LS area	LS0000-	4040	Word Address

■ Sharp

New Satellite JW Series

	Device	Word Address	Device code (HEX)	Address code
Bit Device	Relay	A0000~ (0000~)	9000	Save as word address value divided by 2.
Word Device	Timer/Counter (current value)	T0000~	6000	Word Address
		B0000~ (b0000~)	7000	Save as word address value divided by 2.
	Register	09000~	0000	Save as word address value divided by 2.
		19000~	0200	Save as word address value divided by 2.
		29000~	0400	Save as word address value divided by 2.
		39000~	0600	Save as word address value divided by 2.
		49000~	0800	Save as word address value divided by 2.
		59000~	0A00	Save as word address value divided by 2.
		69000~	0C00	Save as word address value divided by 2.
		79000~	0E00	Save as word address value divided by 2.
		89000~	1000	Save as word address value divided by 2.
	99000~	1200	Save as word address value divided by 2.	
	File Register	1000000~	X	X
LS area	LS0000~	4000	Word Address	

■ Matsushita Electric Works

MEWNET Series

	Device	Word Address	Device code (HEX)	Address code
Bit Device	Input Relay	WX000~	8000	Word Address
	Output Relay	WY000~	8800	Word Address
	Internal Relay	WR000~	9000	Word Address
	Link Relay	WL000~	C800	Word Address
	Special Relay	WR900~	9000	Word Address
Word Device	Timer/Counter (elapsed value)	EV0000~	6000	Word Address
	Timer/Counter (elapsed value)	SV0000~	6800	Word Address
	Data Register/ Special Data Register	DT000~	0000	Word Address
	Link Register	Ld0000~	4800	Word Address
	File Register	FL00000~	5800	Word Address
	Special Data Register	DT90000~	7000	Word Address
	LS area	LS0000~	4000	Word Address

■ Yokogawa Electric
FA500 (1:1 communication)*

	Device	Word Address	Device code (HEX)	Address code
Bit Device	Input Relay	X00201~	X	X
	Output Relay	Y00201~	X	X
	Internal Relay	I0001~	9000	Save as word address value minus 1 divided by 16.
	Joint Relay	E0001~	B800	Save as word address value minus 1 divided by 16.
	Special Relay	M001~	B000	Save as word address value minus 1 divided by 16.
	Link Relay	L0001~	C000	Save as word address value minus 1 divided by 16.
Word Device	Timer (current value)	TP001~	6000	Save as word address value minus 1.
	Timer (set value)	TS001~	6800	Save as word address value minus 1.
	Counter (current value)	CP001~	7000	Save as word address value minus 1.
	Counter (set value)	CS001~	7800	Save as word address value minus 1.
	Data Register	D0001~	0000	Save as word address value minus 1.
	Common Register	B0001~	2000	Save as word address value minus 1.
	Special Register	Z001~	5000	Save as word address value minus 1.
	Link Register	W0001~	5800	Save as word address value minus 1.
	LS area	LS0000~	4000	Word Address

* Only CPU No. 1 is available.

FA500 (1:n communication)*

	Device	Word Address	Device code (HEX)	Address code
Bit Device	Input Relay	X00201~	X	X
	Output Relay	Y00201~	X	X
	Internal Relay	I0001~	9000	Save as word address value minus 1 divided by 16.
	Joint Relay	E0001~	B800	Save as word address value minus 1 divided by 16.
	Special Relay	M001~	B000	Save as word address value minus 1 divided by 16.
	Link Relay	L0001~	C000	Save as word address value minus 1 divided by 16.
Word Device	Timer (current value)	TP001~	6000	Save as word address value minus 1.
	Timer (set value)	TS001~	6800	Save as word address value minus 1.
	Counter (current value)	CP001~	7000	Save as word address value minus 1.
	Counter (set value)	CS001~	7800	Save as word address value minus 1.
	Data Register	D0001~	0000	Save as word address value minus 1.
	Common Register	B0001~	2000	Save as word address value minus 1.
	Special Register	Z001~	5000	Save as word address value minus 1.
	Link Register	W0001~	5800	Save as word address value minus 1.
	LS area	LS0000~	4000	Word Address

* Only CPU No. 1 in station No.1 is available.

FA-M3 (1:1 communication)*

	Device	Word Address	Device code (HEX)	Address code
Bit Device	Input Relay	X00201~	X	X
	Output Relay	Y00201~	X	X
	Internal Relay	I0001~	9000	Save as word address value minus 1 divided by 16.
	Joint Relay	E0001~	B800	Save as word address value minus 1 divided by 16.
	Special Relay	M0001~	B000	Save as word address value minus 1 divided by 16.
	Link Relay	L00001~	C000	Save as word address value minus 1 divided by 16.
Word Device	Timer (current value)	TP0001~	6000	Save as word address value minus 1.
	Timer (set value)	TS0001~	6800	Save as word address value minus 1.
	Counter (current value)	CP0001~	7000	Save as word address value minus 1.
	Counter (set value)	CS0001~	7800	Save as word address value minus 1.
	Data Register	D0001~	0000	Save as word address value minus 1.
	File Register	B00001~	2000	Save as word address value minus 1.
		B65537~	2800	Save as word address value minus 65537.
		B131073~	1000	Save as word address value minus 131073.
		B196609~	1800	Save as word address value minus 196609.
	Joint Register	R0001~	0800	Save as word address value minus 1.
	Special Register	Z001~	5000	Save as word address value minus 1.
	Link Register	W00001~	5800	Save as word address value minus 1.
	LS area	LS0000~	4000	Word Address

* Only CPU No. 1 is available.

FA-M3 (1:n communication)*

	Device	Word Address	Device code (HEX)	Address code
Bit Device	Input Relay	X00201~	X	X
	Output Relay	Y00201~	X	X
	Internal Relay	I00001~	9000	Save as word address value minus 1 divided by 16.
	Joint Relay	E0001~	B800	Save as word address value minus 1 divided by 16.
	Special Relay	M0001~	B000	Save as word address value minus 1 divided by 16.
	Link Relay	L00001~	C000	Save as word address value minus 1 divided by 16.
Word Device	Timer (current value)	TP0001~	6000	Save as word address value minus 1.
	Timer (set value)	TS0001~	6800	Save as word address value minus 1.
	Counter (current value)	CP0001~	7000	Save as word address value minus 1.
	Counter (set value)	CS0001~	7800	Save as word address value minus 1.
	Data Register	D0001~	0000	Save as word address value minus 1.
	File Register	B0001~	2000	Save as word address value minus 1.
	Joint Register	R0001~	0800	Save as word address value minus 1.
	Special Register	Z001~	5000	Save as word address value minus 1.
	Link Register	W0001~	5800	Save as word address value minus 1.
LS area	LS0000~	4000	Word Address	

* Only CPU No. 1 in station No. 1 is available.

FA-M3 (Ethernet communication)*

	Device	Word Address	Device code (HEX)	Address code
Bit Device	Input Relay	X00201~	X	X
	Output Relay	Y00201~	X	X
	Internal Relay	I00001~	9000	Save as word address value minus 1 divided by 16.
	Joint Relay	E0001~	B800	Save as word address value minus 1 divided by 16.
	Special Relay	M0001~	B000	Save as word address value minus 1 divided by 16.
	Link Relay	L00001~	C000	Save as word address value minus 1 divided by 16.
Word Device	Timer (current value)	TP0001~	6000	Save as word address value minus 1.
	Timer (set value)	TS0001~	6800	Save as word address value minus 1.
	Counter (current value)	CP0001~	7000	Save as word address value minus 1.
	Counter (set value)	CS0001~	7800	Save as word address value minus 1.
	Data Register	D0001~	0000	Save as word address value minus 1.
	File Register	B0001~	2000	Save as word address value minus 1.
		B65537~	2800	Save as word address value minus 65537.
		B131073~	1000	Save as word address value minus 131073.
		B196609~	1800	Save as word address value minus 196609.
	Joint Register	R0001~	0800	Save as word address value minus 1.
	Special Register	Z001~	5000	Save as word address value minus 1.
	Link Register	W0001~	5800	Save as word address value minus 1.
LS area	LS0000~	4000	Word Address	

* Only CPU No. 1 is available

■ Toyota Machine Works

TOYOPUC-PC2 Series

	Device	Word Address	Device code (HEX)	Address code
Bit Device	Input Relay	X0000~	8000	Word Address
	Output Relay	Y0000~	8800	Word Address
	Internal Relay	M0000~	9000	Word Address
	Keep Relay	K0000~	C 000	Word Address
	Link Relay	L0000~	C 800	Word Address
Word Device	Register (current value)	N0000~	6000	Word Address
	Data Register	D0000~	0000	Word Address
	Link Register	R0000~	4800	Word Address
	File Register	B0000~	7800	Word Address
	Special Register	S0000~	5000	Word Address
	LS area	LS0000~	4000	Word Address

TOYOPUC-PC3J Series

	Device	Word Address	Device Code	Address Code
Bit Device	Input	1X0000 ~	8000	Word Address
		2X0000 ~	8200	Word Address
		3X0000 ~	8400	Word Address
	Output	1Y0000 ~	8800	Word Address
		1Y0000 ~	8A00	Word Address
		1Y0000 ~	8C00	Word Address
	Internal Relay	1M0000 ~	9000	Word Address
		2M0000 ~	9200	Word Address
		3M0000 ~	9400	Word Address
	Keep Relay	1K0000 ~	C000	Word Address
		1K0000 ~	C200	Word Address
		1K0000 ~	C400	Word Address
	Link Relay	1L0000 ~	C800	Word Address
		2L0000 ~	CA00	Word Address
		3L0000 ~	CC00	Word Address
	Special Relay	1V0000 ~	B000	Word Address
		2V0000 ~	B200	Word Address
		3V0000 ~	B400	Word Address
	Timer	1T0000 ~	E000	Word Address
		2T0000 ~	E200	Word Address
		3T0000 ~	E400	Word Address
	Counter	1C0000 ~	F000	Word Address
		2C0000 ~	F200	Word Address
		3C0000 ~	F400	Word Address
	Exp. Input	EX0000 ~	8600	Word Address
	Exp. Output	EY0000 ~	8E00	Word Address
	Exp. Internal Relay	EM0000 ~	9600	Word Address
Exp. Keep Relay	EK0000 ~	C600	Word Address	
Exp. Link Relay	EL0000 ~	CE00	Word Address	
Exp. Special Relay	EV0000 ~	B600	Word Address	
Exp. Timer	ET0000 ~	E600	Word Address	
Exp. Counter	EC0000 ~	F600	Word Address	
Word Device	Data Register	1D0000 ~	0000	Word Address
		2D0000 ~	0200	Word Address
		3D0000 ~	0400	Word Address
	Link Register	1R0000 ~	4800	Word Address
		2R0000 ~	4A00	Word Address
		3R0000 ~	4C00	Word Address
	Special Register	1S0000 ~	5000	Word Address
		2S0000 ~	5200	Word Address
		3S0000 ~	5400	Word Address
	Current Value Register	1N0000 ~	6000	Word Address
		2N0000 ~	6200	Word Address
		3N0000 ~	6400	Word Address
	File Register	B0000 ~	7800	Word Address
	Exp. Special Register	ES0000 ~	5600	Word Address
	Exp. Current Value Register	EN0000 ~	6600	Word Address
Exp. Setting Value Register	H0000 ~	7600	Word Address	
Exp. Data Register	U0000 ~	0600	Word Address	
LS Area	LS0000 ~	4000	Word Address	

■ Toshiba

PROSEC EX Series

	Device	Word Address	Device code (HEX)	Address code
Bit Device	External Input	XW0000~	8040	Word Address
	External Output	YW0000~	8840	Word Address
	Auxiliary Relay	RW0000~	9040	Word Address
	Link Register (relay)	ZW0000~	C840	Word Address
Word Device	Timer (current value)	T0000~	6000	Word Address
	Counter (current value)	C0000~	7000	Word Address
	Data Register	D00000~	0040	Word Address
	LS area	LS0000~	4040	Word Address

PROSEC T Series

	Device	Word Address	Device code (HEX)	Address code
Bit Device	External Input	XW000~	8000	Word Address
	External Output	YW000~	8800	Word Address
	Internal Output	RW000~	9000	Word Address
	Special Relay	SW000~	B000	Word Address
Word Device	Timer (current value)	T000~	6000	Word Address
	Counter (current value)	C000~	7000	Word Address
	Data Register	D0000~	0000	Word Address
	Link Register	W0000~	4800	Word Address
	File Register	F0000~	5800	Word Address
	LS area	LS0000~	4000	Word Address

PROVISOR B Series

	Device	Word Address	Device code (HEX)	Address code
Bit Device	Input Relay	XW00~	8000	Word Address
	Output Relay	YW00~	8800	Word Address
	Internal Relay	RW00~	9000	Word Address
	Extended Internal Relay-1	GW00~	9200	Word Address
	Extended Internal Relay-2	HW00~	9400	Word Address
	Special Auxiliary Relay	AW00~	B000	Word Address
	Latch Relay	LW00~	C000	Word Address
	Shift Register	SW00~	C200	Word Address
	Edge Relay	EW00~	C400	Word Address
	Timer (contact)	TW00~	E000	Word Address
	Counter (contact)	CW00~	F000	Word Address
Word Device	Timer/Counter (current value)	P000~	6000	Word Address
	Timer/Counter (set value)	V000~	7000	Word Address
	Generic Register 1	D000~	0000	Word Address
	Generic Register 2	B000~	2000	Word Address
	LS area	LS0000~	4000	Word Address

■ Toshiba Machine

PROVISOR TC200 Series

	Device	Word Address	Device code (HEX)	Address code
Bit Device	Input Relay	XW00~	8000	Word Address
	Output Relay	YW00~	8800	Word Address
	Internal Relay	RW00~	9000	Word Address
	Extended Internal Relay-1	GW00~	9200	Word Address
	Extended Internal Relay-2	HW00~	9400	Word Address
	Special Auxiliary Relay	AW00~	B000	Word Address
	Latch Relay	LW00~	C000	Word Address
	Shift Register	SW00~	C200	Word Address
	Edge Relay	EW00~	C400	Word Address
	Timer (contact)	TW00~	E000	Word Address
	Counter (contact)	CW00~	F000	Word Address
Word Device	Timer/Counter (current value)	P000~	6000	Word Address
	Timer/Counter (set value)	V000~	7000	Word Address
	Generic Register 1	D000~	0000	Word Address
	Generic Register 2	B000~	2000	Word Address
	LS area	LS0000~	4000	Word Address

■ Koyo Electronics Industries

KOSTAC SG Series

	Device	Word Address	Device code (HEX)	Address code
Bit Device	Input Relay	R40400~	8100	Save as word address value minus 40400.
	Output Relay	R40500~	8900	Save as word address value minus 40500.
	Internal Relay	R40600~	9100	Save as word address value minus 40600.
	Stage	R41000~	A100	Save as word address value minus 41000.
	Link Relay (input)	R40000~	C900	Save as word address value minus 40000.
	Specified Transfer Relay (output)	R40200~	CD00	Save as word address value minus 40200.
	Timer (contact)	R41100~	E100	Save as word address value minus 41100.
	Counter (contact)	R41140~	F100	Save as word address value minus 41140.
Word Device	Timer (elapsed value)	R0000~	6000	Word Address
	Counter (elapsed value)	R1000~	7000	Save as word address value minus 1000.
	Data Memory 1	R400~	0800	Save as word address value minus 400.
	Data Memory 2	R1400~	0000	Save as word address value minus 1400.
	Data Memory 3	R10000~	5800	Save as word address value minus 10000.
	LS area	LS0000~	4000	Word Address

KOSTAC SU Series

	Device	Word Address	Device code (HEX)	Address code
Bit Device	Input Relay	R40400~	8100	Save as word address value minus 40400.
	Output Relay	R40500~	8900	Save as word address value minus 40500.
	Internal Relay	R40600~	9100	Save as word address value minus 40600.
	Stage	R41000~	A 100	Save as word address value minus 41000.
	Link Relay/Link Input	R40000~	C 900	Save as word address value minus 40000.
	Special Relay	R41200~ R41215~	B 100	Save as word address value minus 41200.
	Timer (contact)	R41100~	E 100	Save as word address value minus 41100.
	Counter (contact)	R41140~	F 100	Save as word address value minus 41140.
Word Device	Timer (elapsed value)	R0000~	6000	Word Address
	Counter (elapsed value)	R1000~	7000	Save as word address value minus 1000.
	Data Register	R1400~	0000	Save as word address value minus 1400.
	Special Register	R700~ R7400~	X	X
	Extended Register	R10000~	5800	Save as word address value minus 10000.
	LS area	LS0000~	4000	Word Address

KOSTAC SZ Series

	Device	Word Address	Device code (HEX)	Address code
Bit Device	Input Relay	R40400~	8100	Save as word address value minus 40400.
	Output Relay	R40500~	8900	Save as word address value minus 40500.
	Internal Relay	R40600~	9100	Save as word address value minus 40600.
	Stage	R41000~	A100	Save as word address value minus 41000.
	Timer (contact)	R41100~	E100	Save as word address value minus 41100.
	Counter (contact)	R41140~	F100	Save as word address value minus 41140.
Word Device	Timer (elapsed value)	R0000~	6000	Word Address
	Counter (elapsed value)	R1000~	7000	Save as word address value minus 1000.
	Data Memory 2	R2000~	0000	Save as word address value minus 1400.
	LS area	LS0000~	4000	Word Address

KOSTAC SR Series

	Device	Word Address	Device code (HEX)	Address code
Bit Device	Input/Output	R000~	9000	Save as word address value divided 2.
		R070~	9000	Save as word address value divided 2.
	Internal Relay	R016~	9000	Save as word address value divided 2.
		R076~	9000	Save as word address value divided 2.
	Shift Register	R040~	9000	Save as word address value divided 2.
	Timer/Counter (contact)	R060~	9000	Save as word address value divided 2.
Word Device	Timer/Counter (elapsed value)	R600~	6000	Save as word address value minus 600.
	Data Register	R400~	0000	Save as word address value minus 400 divided by 2.
	LS area	LS0000~	4000	Word Address

DL-405 Series

	Device	Word Address	Device code (HEX)	Address code
Bit Device	Input Relay	V40400~	8100	Save as word address value minus 40400.
	Output Relay	V40500~	8900	Save as word address value minus 40500.
	Internal Relay	V40600~	9100	Save as word address value minus 40600.
	Stage	V41000~	A100	Save as word address value minus 41000.
	Link Relay/Link Input	V40000~	C900	Save as word address value minus 40000.
	Special Relay	V41200~ V41215~	B100	Save as word address value minus 41200.
	Timer (contact)	V41100~	E100	Save as word address value minus 41100.
	Counter (contact)	V41140~	F100	Save as word address value minus 41140.
Word Device	Timer (elapsed value)	V0000~	6000	Word Address
	Counter (elapsed value)	V1000~	7000	Save as word address value minus 1000.
	Data Register	V1400~	0000	Save as word address value minus 1400.
	Special Register	V700~ V7400~	X	X
	Extended Register	V10000~	5800	Save as word address value minus 10000.
	LS area	LS0000~	4000	Word Address

DL-205 Series

	Device	Word Address	Device code (HEX)	Address code
Bit Device	Input Relay	V40400~	8100	Save as word address value minus 40400.
	Output Relay	V40500~	8900	Save as word address value minus 40500.
	Internal Relay	V40600~	9100	Save as word address value minus 40600.
	Stage	V41000~	A100	Save as word address value minus 41000.
	Timer (contact)	V41100~	E100	Save as word address value minus 41100.
	Counter (contact)	V41140~	F100	Save as word address value minus 41140.
Word Device	Timer (elapsed value)	V0000~	6000	Word Address
	Counter (elapsed value)	V1000~	7000	Save as word address value minus 1000.
	Data Memory 2	V2000~	0000	Save as word address value minus 1400.
	LS area	LS0000~	4000	Word Address

DL-305 Series

	Device	Word Address	Device code (HEX)	Address code
Bit Device	Input/Output	V000~	9000	Save as word address value divided 2.
		V070~	9000	Save as word address value divided 2.
	Internal Relay	V016~	9000	Save as word address value divided 2.
		V076~	9000	Save as word address value divided 2.
	Shift Register	V040~	9000	Save as word address value divided 2.
	Timer/Counter (contact)	V060~	9000	Save as word address value divided 2.
Word Device	Timer/Counter (elapsed value)	V600~	6000	Save as word address value minus 600.
	Data Register	V400~	0000	Save as word address value minus 400 divided by 2.
	LS area	LS0000~	4000	Word Address

■ GE Fanuc Automation

Series 90-70/90-30 (SNP-X protocol)

	Device	Word Address	Device code (HEX)	Address code
Bit Device	Input Relay (I)	I00001~	8000	Save as word address value minus 1 divided by 16.
	Output Relay (Q)	Q00001~	8800	Save as word address value minus 1 divided by 16.
	Internal Relay (M)	M00001~	9000	Save as word address value minus 1 divided by 16.
	Global Relay (G)	G0001~	C200	Save as word address value minus 1 divided by 16.
	Momentary Relay (T)	T001~	9400	Save as word address value minus 1 divided by 16.
	System Function Relay (SA)	SA001~	A200	Save as word address value minus 1 divided by 16.
	System Function Relay (SB)	SB001~	A400	Save as word address value minus 1 divided by 16.
	System Function Relay (SC)	SC001~	A800	Save as word address value minus 1 divided by 16.
	System Function Relay (S)	S001~	AA00	Save as word address value minus 1 divided by 16.
Word Device	Register (R)	R00001~	0000	Save as word address value minus 1.
	Analog Input (AI)	AI0001~	0A00	Save as word address value minus 1.
	Analog Output (AQ)	AQ0001~	0C00	Save as word address value minus 1.
	LS area	LS0000~	4000	Word Address

Series 90-70/90-30 (SNP protocol)

	Device	Word Address	Device Code	Address Code
Bit Device	Input Relay (I)	I00001~	8000	Save as: word address value minus 1, then divided by 16
	Output Relay (Q)	Q00001~	8800	Save as: word address value minus 1, then divided by 16
	Internal Relay (M)	M00001~	9000	Save as: word address value minus 1, then divided by 16
	Global Relay (G)	G0001~	C200	Save as: word address value minus 1, then divided by 16
	Temporary Relay (T)	T001~	9400	Save as: word address value minus 1, then divided by 16
	System Status Relay (SA)	SA001~	A200	Save as: word address value minus 1, then divided by 16
	System Status Relay (SB)	SB001~	A400	Save as: word address value minus 1, then divided by 16
	System Status Relay (SC)	SC001~	A800	Save as: word address value minus 1, then divided by 16
	System Status Relay (S)	S001~	AA00	Save as: word address value minus 1, then divided by 16

	Device	Word Address	Device Code	Address Code
Word Device	Register (R)	R00001~	0000	Save as word address value minus 1
		R01025~	1000	Save as word address value minus 1025
		R02049~	1200	Save as word address value minus 2049
		R03073~	1400	Save as word address value minus 3073
		R04097~	1600	Save as word address value minus 4097
		R05121~	1800	Save as word address value minus 5121
		R06145~	1A00	Save as word address value minus 6145
		R07169~	1C00	Save as word address value minus 7169
		R08193~	1E00	Save as word address value minus 8193
		R09217~	2000	Save as word address value minus 9217
		R10241~	2200	Save as word address value minus 10241
		R11265~	2400	Save as word address value minus 11265
		R12289~	2600	Save as word address value minus 12289
		R13313~	2800	Save as word address value minus 13313
		R14337~	2A00	Save as word address value minus 14337
		R15361~	2C00	Save as word address value minus 15361
	Analog Input (AI)	AI0001~	0A00	Save as word address value minus 1
		AI1025~	3000	Save as word address value minus 1025
		AI2049~	3200	Save as word address value minus 2049
		AI3073~	3400	Save as word address value minus 3073
		AI4097~	3600	Save as word address value minus 4097
		AI5121~	3800	Save as word address value minus 5121
		AI6145~	3A00	Save as word address value minus 6145
		AI7169~	3C00	Save as word address value minus 7169
	Analog Output (AQ)	AQ0001~	0C00	Save as word address value minus 1
		AQ1025~	5000	Save as word address value minus 1025
		AQ2049~	5200	Save as word address value minus 2049
		AQ3073~	5400	Save as word address value minus 3073
		AQ4097~	5600	Save as word address value minus 4097
		AQ5121~	5800	Save as word address value minus 5121
		AQ6145~	5A00	Save as word address value minus 6145
		AQ7169~	5C00	Save as word address value minus 7169
	LS Area	LS0000~	4000	Save as word address value

■ Fanuc Motion Controller
FANUC Power Mate Series

	Device	Word Address	Device code (HEX)	Address code
Bit Device	Input Relay (X)	X00000~ X01000~	8000	Save as word address value minus 1 divided by 2.
	Output Relay (Y)	Y00000~ Y01000~	9000	Save as word address value minus 1 divided by 2.
	Internal Relay (R)	R00000~	C000	Save as word address value minus 1 divided by 2.
	Keep Relay (K)	K0000~	D000	Save as word address value minus 1 divided by 2.
Word Device	Timer (T)	T0000~	6800	Save as word address value minus 1 divided by 2.
	Counter (C)	C0000~	7800	Save as word address value minus 1 divided by 2.
	Data Table (D)	D00000~	0000	Save as word address value minus 1 divided by 2.
	LS area	LS0000~	4000	Word Address

■ IDEC Izumi

FA Series

	Device	Word Address	Device code (HEX)	Address code
Bit Device	Input Relay	WX00~	8000	Save as word address value divided by 2.
	Output Relay	WY000~	8800	Save as word address value divided by 2.
	Internal Relay	WM000~	9000	Save as word address value divided by 2.
	Shift Register	WR000~	C000	Save as word address value divided by 16.
Word Device	Timer (set value)	TS000~	6800	Word Address
	Timer (current value)	T000~	6000	Word Address
	Timer 10msec (current value)	H000~	6400	Word Address
	Counter (set value)	CS000~	7800	Word Address
	Counter (current value)	C000~	7000	Word Address
	Data Register	D0000~	0000	Word Address
	Control Register	D3000~	0000	Word Address
	LS area	LS0000~	4000	Word Address

MICRO³ (Micro Cube)

	Device	Word Address	Device code (HEX)	Address code
Bit Device	Input Relay	X0000~	8000	Save as word address value divided by 2.
	Output Relay	Y0000~	8800	Save as word address value divided by 2.
	Internal Relay	M0000~	9000	Save as word address value divided by 2.
	Shift Register	R0000~	C000	Save as word address value divided by 16.
Word Device	Timer (set value)	T0000~	6800	Word Address
	Timer (current value)	t0000~	6000	Word Address
	Counter (set value)	C0000~	7800	Word Address
	Counter (current value)	c0000~	7000	Word Address
	Data Register	D0000~	0000	Word Address
	LS area	LS0000~	4000	Word Address

MICROSmart FC4A Series/OpenNet Controller FC3 Series

	Device	Word Address	Device code (HEX)	Address code
Bit Device	Input	X000 ~	8000	Save as word address value divided by 2
	Output	Y000 ~	8800	Save as word address value divided by 2
	Internal Relay	M000 ~	9000	Save as word address value divided by 2
	Special Internal Relay	M800 ~	9800	Save as word address value divided by 2
	Shift Register	R0000 ~	C000	Save as word address value divided by 16
Word Device	Timer (setup value)	T0000 ~	6800	Word Address
	Timer (setup value)	t0000 ~	6000	Word Address
	Counter (elapsed value)	C0000 ~	7800	Word Address
	Counter (elapsed value)	c0000 ~	7000	Word Address
	Data Register	D0000 ~	0000	Word Address
	Special Data Register	D8000 ~	5000	Word Address
	Link Register	L0100 ~	2000	Word Address
	Enter Timer/Counter Setting Value	Q0	3000	Word Address
	LS Area	LS0000 ~	4000	Word Address

■ Siemens

SIMATIC S5 Series (using Link I/F)*

	Device	Word Address	Device code (HEX)	Address code
Word Device	Data Register	D003000~	0040	Upper two digits: Value of "DB number minus 3" is indicated in HEX. Lower two digits: Value that DB number is indicated in HEX.
	Extended Data Register	X0030000~	5840	Upper two digits: Value of "DB number minus 3" is indicated in HEX. Lower two digits: Value that DB number is indicated in HEX.
	LS area	LS0000~	4040	Word Address

* The address codes for Data Register and Extended Data Register are as follows:

E.g. D019255

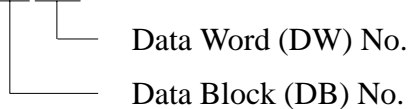

Address code

Upper two digits: 019-3=16 (DEC) ->10 (HEX)

Lower two digits: 255 (DEC) -> FF (HEX)

Address code is 10FF.

SIMATIC S5 Series (CPU Direct Connection)*

	Device	Word Address	Device code (HEX)	Address code
Bit Device	Input Relay	IW000~	8140	Save as address value divided by 2.
	Output Relay	QW000~	8940	Save as address value divided by 2.
	Internal Relay	FW000~	9140	Save as address value divided by 2.
Word Device	Timer	T000~	6000	Word Address
	Counter	C 000~	7000	Word Address
	Data Register	D002000~	0040	Upper two digits: Value of "DB number minus 2" is indicated in HEX. Lower two digits: Value that DB number is indicated in HEX.
	Extended Data Register	X002000~	5840	Upper two digits: Value of "DB number minus 2" is indicated in HEX. Lower two digits: Value that DB number is indicated in HEX.
	LS area	LS0000~	4040	Word Address

* The address codes for Data Register and Extended Data Register are as follows:

E.g. D019 255

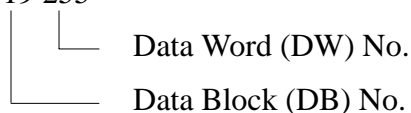

Address code

Upper two digits: 019-2=17 (DEC) ->11 (HEX)

Lower two digits: 255 (DEC) ->FF (HEX)

Address code is 11FF.

SIMATIC S7 300/400 (via MPI)

	Device	Word Address	Device code (HEX)	Address Code
Bit Device	Input Bit	EW00000 ~	8000	Save as word address value divided by 2.
	Output Bit	AW00000 ~	8800	Save as word address value divided by 2.
	Internal Bit	MW00000 ~	9000	Save as word address value divided by 2.
Word Device	Data Block	DB00W00000 ~	7C00	Save as word address value divided by 2.
	Timer Word	T00000 ~	6000	Word Address
	Counter Word	C00000 ~	7000	Word Address

SIMATIC S7 300/400 (via 3964/RK512)

	Device	Word Address	Device code (HEX)	Address Code
Word Device	Data Block	DB00W00000 ~	7C00	Save as word address value divided by 2.

SIMATIC S7 200 (via PPI)

	Device	Word Address	Device code (HEX)	Address Code
Bit Device	Input Bit	IW0 ~	9000	Save as word address value divided by 2.
	Output Bit	QW0 ~	8800	Save as word address value divided by 2.
	Internal Bit	MW00 ~	C800	Save as word address value divided by 2.
	Specioal Memory	SMW00 ~	B800	Save as word address value divided by 2.
	Variable Memory	VW0000 ~	D000	Save as word address value divided by 2.
Word Device	Timer Word	T000 ~	0400	Save as word address value divided by 2.
	Counter Word	C000 ~	0800	Save as word address value divided by 2.

SIMATIC 505

	Device	Word Address	Device Code (HEX)	Address Code
Word Device	Variable Memory	V00001 ~	0000	Word Address minus 1
	Word Input	WX00001 ~	0C00	Word Address minus 1
	Word Output	WY00001 ~	0E00	Word Address minus 1
	Loop Gain	LKC0001 ~	1C00	Word Address minus 1
	Loop Reset	LTIO001 ~	1E00	Word Address minus 1
	Loop Rate	LTD0001 ~	2000	Word Address minus 1
	Loop Alarm High Limit	LHA0001 ~	2400	Word Address minus 1
	Loop Low Alarm Limit	LLA0001 ~	2800	Word Address minus 1
	Loop Process Variable	LPV0001 ~	2C00	Word Address minus 1
	Loop PV High Limit	LPVH0001 ~	2E00	Word Address minus 1
	Loop PV Low Limit	LPVL0001 ~	3000	Word Address minus 1
	Loop Orange Deviation Limit	LODA0001 ~	3400	Word Address minus 1
	Loop Yellow Deviation Alarm Limit	LYDA0001 ~	3800	Word Address minus 1
	Loop Sample Rate	LTS0001 ~	3A00	Word Address minus 1
	Loop Setpoint	LSP0001 ~	3E00	Word Address minus 1
	Loop Output	LMN0001 ~	4400	Word Address minus 1
	Loop Error	LERR0001 ~	4800	Word Address minus 1
	Loop Bias	LMX0001 ~	4E00	Word Address minus 1
	Loop Alarm High-High Limit	LHHA0001 ~	5000	Word Address minus 1
	Loop Low-Low Alarm Unit	LLLA0001 ~	5400	Word Address minus 1
	Loop Rate of Change Alarm Limit	LRC A0001 ~	5600	Word Address minus 1
	Loop Setpoint High Limit	LSPH0001 ~	5A00	Word Address minus 1
Loop Setpoint Low Limit	LSPL0001 ~	6000	Word Address minus 1	
Loop Alarm Deadband	LADB0001 ~	6200	Word Address minus 1	
LS Area	LS0000 ~	4000	Word Address	

SIMATIC 505 (From previous page)

	Device	Word Address	Device Code (HEX)	Address Code
Word Device	Loop V-flags	LVF0001 ~	6400	Word Address
	Most Significant Word of Loop C-flags	LCFH0001 ~	6600	Word Address
	Least Significant Word of Loop C-flags	LCFL0001 ~	6800	Word Address
	Analog Alarm/Alarm Acknowledge Flags	AADB0001 ~	6C00	Word Address
	Most Significant Word of Analog Alarm C-flags	ACFH0001 ~	6E00	Word Address
	Least Significant Word of Analog Alarm C-flags	ACFL0001 ~	7000	Word Address
	Analog Alarm Error	AERR0001 ~	7400	Word Address
	Analog Alarm High Alarm Limit	AHA0001 ~	7800	Word Address
	Analog Alarm High-High Alarm Limit	AHHA0001 ~	7C00	Word Address
	Analog Alarm Low Alarm Limit	ALA0001 ~	7E00	Word Address
	Analog Alarm Low-Low Alarm Limit	ALLA0001 ~	7A00	Word Address
	Analog Alarm Loop Orange Deviation Alarm Limit	AODA0001 ~	7600	Word Address
	Analog Alarm Process Variable	APV0001 ~	7200	Word Address
	Analog Alarm Rate of Change Alarm Limit	ARCA0001 ~	6A00	Word Address
	Analog Alarm Setpoint	ASP0001 ~	5E00	Word Address
	Analog Alarm SP High Limit	ASPH0001 ~	5800	Word Address
	Analog Alarm SP Low Limit	ASPL0001 ~	5200	Word Address
	Analog Alarm Sample Rate	ATS0001 ~	4C00	Word Address
	Analog Alarm Yellow Deviation Alarm Limit	AYDA0001 ~	4A00	Word Address
	Timer/Counter Preset	TCP0001 ~	2600	Word Address
	Timer/Counter Current	TCC0001 ~	2A00	Word Address
	Drum Counter Preset	DCP0101 ~	3200	Word Address
	Drum Step Preset	DSP0001 ~	3600	Word Address
	Drum Step Current	DSC0001 ~	3C00	Word Address
	Status Word	STW0001 ~	4600	Word Address
	Drum Count Current	DCC0001 ~	4200	Word Address
	LS Area	LS0000 ~	4000	Word Address

■ Rockwell (Allen-Bradley) *
AB SLC500 Series

	Device	Word Address	Device code (HEX)	Address code
Bit Device	Bit	B003000~ B010000~	9040	Upper two digits: Value of "DB number minus 3" is indicated in HEX. Lower two digits: Value that DB number is indicated in HEX.
Word Device	Timer (PRE: set value)	TP004000~ TP010000~	6800	Upper two digits: Value of "DB number minus 4" is indicated in HEX. Lower two digits: Value that DB number is indicated in HEX.
	Timer (ACC: current value)	TA004000~ TA010000~	6000	Upper two digits: Value of "DB number minus 4" is indicated in HEX. Lower two digits: Value that DB number is indicated in HEX.
	Counter (PRE: set value)	CP005000~ CP010000~	7800	Upper two digits: Value of "DB number minus 5" is indicated in HEX. Lower two digits: Value that DB number is indicated in HEX.
	Counter (ACC: current value)	CA005000~ CA010000~	7000	Upper two digits: Value of "DB number minus 5" is indicated in HEX. Lower two digits: Value that DB number is indicated in HEX.
	Integral Number	N007000~ N010000~	0040	Upper two digits: Value of "DB number minus 7" is indicated in HEX. Lower two digits: Value that DB number is indicated in HEX.
	LS area	LS0000~	4040	Word Address

* The address codes for Data Register and Extended Data Register are as follows:

Ex. B019 255

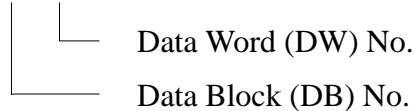

Address code

Upper two digits: 019-3=16 (DEC) -> 10 (HEX)

Lower two digits: 255 (DEC) -> FF (HEX)

Address code is 10FF.

AB PLC-5 Series

	Device	Word Address	Device code (HEX)	Address code
Bit Device	Input Relay	I000~	8040	Word Address
	Output Relay	O000~	8840	Word Address
	Internal Relay	B3000~	9040	Save as word address value minus 3000.
Word Device	Timer (ACC: current value)	TA3000~	6000	Save as word address value minus 3000.
	Timer (PRE: set value)	TP3000~	6800	Save as word address value minus 3000.
	Counter (ACC: current value)	CA3000~	7000	Save as word address value minus 3000.
	Counter (PRE: set value)	CP3000~	7800	Save as word address value minus 3000.
	Data Register Integer	N3000~	0040	Save as word address value minus 3000.
	Data Register BCD	D3000~	0240	Save as word address value minus 3000.
	Data Register ASCII	A3000~	0440	Save as word address value minus 3000.
	LS area	LS0000~	4040	Word Address

■ **Keyence**

KZ-300/KZ-350 Series

	Device	Word Address	Device code (HEX)	Address code
Bit Device	Input Relay	00~	9100	Word Address
		70~	9100	Word Address
	Output Relay	05~	9100	Word Address
		75~	9100	Word Address
	Internal Auxiliary Relay	10~	9100	Word Address
	Special Auxiliary Relay	20~	9100	Word Address
Word Device	Timer (current value)	T000~	6000	Word Address
	Counter (current value)	C000~	7000	Word Address
	Data Memory	DM0000~	0000	Word Address
	Temporary Data Memory	TM00~	C100	Word Address
	LS area	LS0000~	4000	Word Address

KZ-500 Series

	Device	Word Address	Device code (HEX)	Address code
Bit Device	Input Relay	X0000 ~	8000	Word Address'last digit, except "0"
	Output Relay	Y0000 ~	8800	Word Address'last digit, except "0"
	Internal Relay	M0000 ~	9000	Save as Word Address value divided by 16
	Special Relay	M9000 ~	B000	Save as (Word Address value minus 9000) divided by 16
	Latch Relay	L0000 ~	C000	Save as Word Address value divided by 16
	Annunciator Relay	F0000 ~	B800	Save as Word Address value divided by 16
Word Device	Timer (current value)	TN0000 ~	6000	Word Address
	Counter (current value)	CN0000 ~	7000	Word Address
	Data Register	D0000 ~	0000	Word Address
	Special Register	D9000 ~	0000	Word Address
	Link Register	W0000 ~	4800	Word Address
	File Register	R0000 ~	5800	Word Address
	LS area	LS0000 ~	4000	Word Address

■ **Shinko Electric**

SELMART Series

	Device	Word Address	Device code (HEX)	Address code
Word Device	Data Register	D00000~	0000	Word Address
	LS area	LS0000~	4000	Word Address

■ **Matsushita Electric Industrial**

Panadac P7000 Series

	Device	Word Address	Device code (HEX)	Address code
Bit Device	Input Relay	IN0000~	8000	Word Address
	Output Relay	OT0000~	8800	Word Address
	Internal Relay	RL0000~	9000	Word Address
	Hold Relay	KR0000~	C000	Word Address
	Link Relay	LK0000~	C800	Word Address
	Status Relay	ST0000~	9800	Word Address
	MC Status Relay	MS0000~	9A00	Word Address
	Timer State Relay	TS0000~	E200	Word Address
	Timer Up Relay	TU0000~	E000	Word Address
	Count Up Relay	CU0000~	F000	Word Address
	CPU Input Relay	CI0000~	8200	Word Address
	CPU Output Relay	CO0000~	8A00	Word Address
Word Device	Data Memory	M0000~	0000	Word Address
	Link Register	LM0000~	4800	Word Address
	Timer (setting value)	TM0000~	6800	Word Address
	Timer (current value)	CT0000~	6000	Word Address
	Counter value	TC0000~	7000	Word Address
	Position Data	PM0000~	0800	Word Address
	LS Area	LS0000~	4000	Word Address

■ **ORIM VEXTA**

	Device	Word Address	Device code (HEX)	Address code
Bit Device	Input Register	I0001 ~	8000	Word Address minus 1.
	ON Event Input Register	IU001 ~	8800	Word Address minus 1.
	OFF Event Input Register	ID001 ~	9000	Word Address minus 1.
	Output Register	O0001 ~	B000	Word Address minus 1.
	Position Register	M0001 ~	C800	Word Address minus 1.
	Universal Register Double-Length	RD001 ~	E000	Word Address minus 1.
	Base Register	B000 ~	F000	Word Address
	Current Motor Status	MS001 ~	A800	Word Address minus 1.
	SY Register	SY001 ~	D000	Word Address minus 1.
Word Device	Analog Input Register	AD001 ~	5800	Word Address minus 1.
	Analog Output Register	DA001 ~	4800	Word Address minus 1.
	Speed Register Low	SL001 ~	6800	Word Address minus 1.
	Speed Register High	SH001 ~	7000	Word Address minus 1.
	Speed Register Raise	SR001 ~	7800	Word Address minus 1.
	Speed Register Decrease	SD001 ~	1000	Word Address minus 1.
	Current Motor Position	MP001	3800	Word Address minus 1.
	Universal Register	R0001 ~	0000	Word Address minus 1.
	LS area	LS0000 ~	4000	Word Address

■ **FATEK**

Facon FB 20MC

	Device	Word Address	Device code (HEX)	Address code
Bit Device	Input points	WX000 ~	0400	Save as word address value divided by 16.
	Output Relays	WY000 ~	0800	Save as word address value divided by 16.
	Internal Relays	WM0000 ~	1000	Save as word address value divided by 16.
	Special Relays	WSM1912 ~	2000	Save as word address value divided by 16.
	Step Relays	WS000 ~	4200	Save as word address value divided by 16.
Word Device	Timer Registers	TMR000 ~	4400	Word Address
	Counter Registers	CTR000 ~	4800	Word Address
	Data Register	HR0000 ~	0000	Word Address
	Input Registers	IR3840 ~	5000	Word Address
	Output Registers	OR3904 ~	6000	Word Address
	HSC Register	HSC4096 ~	0600	Word Address
	Calendar Register	RTC4128 ~	0C00	Word Address
	Special Register	SR4136 ~	1800	Word Address
	Read-Only Registers	ROR5000 ~	3000	Word Address
LS Area	LS0000 ~	4000	Word Address	

■ Yokogawa/Yokogawa M&C Controllers

	Device	Word Address	Device Code (HEX)	Address Code
Word Device	D	0001 ~	0000	Word Address -1
Bit Device	I	0001 ~	9000	(Word Address-1)÷16

■ Yamatake Controllers

	Device	Word Address	Device Code (HEX)	Address Code
Word Device	Data	0000 ~	8000	Word Address
		1000 ~	8200	Word Address-1000
		2000 ~	8400	Word Address-2000
		3000 ~	8600	Word Address-3000
		4000 ~	8800	Word Address-4000
		5000 ~	9000	Word Address-5000
		6000 ~	9200	Word Address-6000
		7000 ~	9400	Word Address-7000
	8000 ~	9600	Word Address-8000	
	LS Area	LS0000 ~	4000	Word Address

**Unit No. 1 is only available.*

■ RKC INSTRUMENT INC.Controllers

	Device	Word Address	Device Code (HEX)	Address Code
Word Device	—	0000 ~ 02EE	8000	Word Address
	LS Area	LS0000 ~	4000	Word Address

■ Omron Corporation Controllers

	Device	Word Address	Device Code (HEX)	Address Code
Word Device	Variable Areas	C00000 ~	80E0	Word Address
		C10000 ~	82E0	Word Address
		C30000 ~	84E0	Word Address
	Operation Commands	A0000 ~	8660	Word Address
	LS Area	LS0000 ~	40E0	Word Address

■ Shinko Technos Corporation Controllers

C/FC/FIR/GC/FCL/PC-900 Series

	Device	Word Address	Device Code (HEX)	Address Code	
Word Device	Data Items	0001 ~	8000	Word Address -1	
		0401 ~	8200	Word Address -0x401	
		0801 ~	8400	Word Address -0x801	
		0C01 ~	8600	Word Address -0xC01	
		1001 ~	8800	Word Address -0x1001	
		1401 ~	8A00	Word Address -0x1401	
		1801 ~	8C00	Word Address -0x1801	
		1C01 ~	8E00	Word Address -0x1C01	
		2001 ~	9000	Word Address -0x2001	
		2401 ~	9200	Word Address -0x2401	
		2801 ~	9400	Word Address -0x2801	
		2C01 ~	9600	Word Address -0x2C01	
		3001 ~	9800	Word Address -0x3001	
		3401 ~	9A00	Word Address -0x3401	
		3801 ~	9C00	Word Address -0x3801	
		3C01 ~	9E00	Word Address -0x3C01	
		4001 ~	A000	Word Address -0x4001	
		4401 ~	A200	Word Address -0x4401	
		4801 ~	A400	Word Address -0x4801	
		4C01 ~	A600	Word Address -0x4C01	
		5001 ~	A800	Word Address -0x5001	
		5401 ~	AA00	Word Address -0x5401	
		5801 ~	AC00	Word Address -0x5801	
		5C01 ~	AE00	Word Address -0x5C01	
		6001 ~	B000	Word Address -0x6001	
		6401 ~	B200	Word Address -0x6401	
		6801 ~	B400	Word Address -0x6801	
		6C01 ~	B600	Word Address -0x6C01	
		7001 ~	B800	Word Address -0x7001	
		7401 ~	BA00	Word Address -0x7401	
		7801 ~	BC00	Word Address -0x7801	
		7C01 ~	BE00	Word Address -0x7C01	
		Setting Value Memory 1	1S0001 ~	C000	Word Address -1
		Setting Value Memory 2	2S0001 ~	C200	Word Address -1
		Setting Value Memory 3	3S0001 ~	C400	Word Address -1
		Setting Value Memory 4	4S0001 ~	C600	Word Address -1
		Setting Value Memory 5	5S0001 ~	C800	Word Address -1
	Setting Value Memory 6	6S0001 ~	CA00	Word Address -1	
	Setting Value Memory 7	7S0001 ~	CC00	Word Address -1	
	Channel 1	1CH01 ~	D000	Word Address -1	
	Channel 2	2CH01 ~	D200	Word Address -1	
	Channel 3	3CH01 ~	D400	Word Address -1	
Channel 4	4CH01 ~	D600	Word Address -1		
Channel 5	5CH01 ~	D800	Word Address -1		
Channel 6	6CH01 ~	DA00	Word Address -1		
Channel 7	7CH01 ~	DC00	Word Address -1		
Channel 8	8CH01 ~	DE00	Word Address -1		
Channel 9	9CH01 ~	E000	Word Address -1		
Channel 10	10CH01 ~	E200	Word Address -1		
Channel 11	11CH01 ~	E400	Word Address -1		
Channel 12	12CH01 ~	E600	Word Address -1		
Channel 13	13CH01 ~	E800	Word Address -1		
Channel 14	14CH01 ~	EA00	Word Address -1		
Channel 15	15CH01 ~	EC00	Word Address -1		
Channel 16	16CH01 ~	EE00	Word Address -1		
Channel 17	17CH01 ~	F000	Word Address -1		
Channel 18	18CH01 ~	F200	Word Address -1		
Channel 19	19CH01 ~	F400	Word Address -1		
Channel 20	20CH01 ~	F600	Word Address -1		
LS Area	LS0000 ~	4000	Word Address		

**■ Fuji Electric Corporation Controller
Micro-Controller X Series (Model:PxR)**

	Device	Word Address	Device Code (HEX)	Address Code
Bit Device	Parameter	00001 ~	8000	Cannot be set
		10001 ~	8200	Word Address minus 1
Word Device		30001 ~	8400	Word Address minus 1
		40001 ~	8600	Word Address minus 1
		31001 ~	8800	Word Address minus 1
		41001 ~	8A00	Word Address minus 1
	LS Area	LS0000 ~	4000	Word Address

■ TOHO ELECTORICS INC.

TTM Series

	Device	Word Address	Device Code (HEX)	Address Code
Word Device	00_	00_0000 ~ 0075	8000	Word Address
	10_	10_0000 ~ 0025	B000	Word Address
	100_	100_0000 ~ 0032	B200	Word Address
	110_	110_0000 ~ 0041	8200	Word Address
	120_	120_0000 ~ 0043	8400	Word Address
	300_	300_0000 ~ 0067	8600	Word Address
	1020_	1020_0000 ~ 0077	8800	Word Address
	Step Temperature Setting	SSV0000 ~ 2047	9000	Word Address
	Final Step Setting	END0000 ~ 2047	9200	Word Address
	Step time Setting	STI0000 ~ 2047	9400	Word Address
	Final Step Finish Condition Setting	SOK0000 ~ 2047	9600	Word Address
	Step Wait Zone	SWZ0000 ~ 2047	9800	Word Address
	Step Wait Time	SWT0000 ~ 2047	A000	Word Address
	Time Signal ON Time	SON0000 ~ 2047	A200	Word Address
	Time Signal OFF Time	SOF0000 ~ 2047	A400	Word Address
	Execution Time	SRN0000 ~ 2000	A600	Word Address
	End Signal ON Time	SEO0000 ~ 2000	A800	Word Address
	LS area	LS0000 ~	4000	Word Address

■ Memory Link Method

	Word Address	Device code (HEX)	Address code
Word Device	0~	4040	Word Address

■ Device Net

	Device	Word Address	Device code (HEX)	Address code
Word Device	LS area	LS0000 ~	4000	Word Address

■ CC-Link

	Device	Word Address	Device code (HEX)	Address code
Word Device	LS area	LS0000 ~	4000	Word Address

■ CC-Link intelligent Device Station

E-tag or K-tag indirect addresses cannot be designated by CC-Link Intelligent Device Station.

■ Mitsubishi Electronic Corporation Inverter

	Device	Word Address	Device code (HEX)	Address code
Word Device	Parameter (except for Pr.37 of FREQROL-S500 and FREQROL-E500)	0000 ~	8000	Word Address
	Parameter (Pr.37 of FREQROL-S500 or FREQROL-E500)	P0037	8200	Word Address
	Operation mode	OPE0	8400	Word Address
	Output frequency (rpm)	OUTF0	8600	Word Address
	Output current	OUTC0	8800	Word Address
	Output voltage	OUTV0	9000	Word Address
	Special monitor	SPM0	9200	Word Address
	Output frequency	SOF0	9400	Word Address
	Output current	SOC0	9600	Word Address
	Output voltage	SOV0	9800	Word Address
	Set frequency value	FRS0	A000	Word Address
	Run speed	RUNS0	A200	Word Address
	Motor torque	MOT0	A400	Word Address
	Regenerative brake	RBRK0	A600	Word Address
	Electronic thermal load factor	ELOF0	A800	Word Address
	Output current peak value	OCPV0	B000	Word Address
	Converter output voltage peak value	COPK0	B200	Word Address
	Input power	IPOW0	B400	Word Address
	Output power	OPOW0	B600	Word Address
	Alarm (latest Nos. 1 & 2)	A12D0	B800	Word Address
	Alarm (latest Nos. 3 & 4)	A34D0	C000	Word Address
	Alarm (latest Nos. 5 & 6)	A56D0	C200	Word Address
	Alarm (latest Nos. 7 & 8)	A78D0	C400	Word Address
	Run command	RUNC0	C600	Word Address
	Inverter status monitor	INVS0	C800	Word Address
	Run frequency write (E2PROM)	RWRT0	D000	Word Address
	Set frequency write (RAM and E2PROM)	SFWE0	D200	Word Address
	Set frequency write (only RAM)	SFWR0	D400	Word Address
	Set frequency read (E2PROM)	SFRE0	D600	Word Address
	Set frequency read (RAM)	SFRR0	D800	Word Address
	Error all clear	ERCL0	E000	Word Address
	Inverter reset	RSET0	E200	Word Address
	Parameter all clear	ALLC0	E400	Word Address
	User clear			Word Address
Link parameter extended settings	LNKP0	E600	Word Address	
No. 2 parameter change	SECP0	E800	Word Address	
LS area	LS0000 ~	4000	Word Address	

■ Fuji Electronic Corporation Inverter

Device codes and address codes are used to specify indirect addresses for E-tags and K-tags.

	Device	Word Address	Device code (HEX)	Address code
Word Device	Basic function	F00 ~	0000	Word Address
	Terminal function	E01 ~	1000	Word Address minus 1.
	Controlling function	C01 ~	2000	Word Address minus 1.
	Motor 1	P00 ~	3000	Word Address
	High level function	H01 ~	5000	Word Address minus 1.
	Motor 2	A01 ~	6000	Word Address minus 1.
	Option	o00 ~	7000	Word Address
	Command data	S01 ~	1200	Word Address minus 1.
	Monitor data	M01 ~	1400	Word Address minus 1.
	Alarm reset	m00	1600	Word Address
	LS Area	LS0000 ~	4000	Word Address

■ Interbus-S

Direct I/O Mode

	Device	Word Address	Device code (HEX)	Address code
Word Device	LS area	LS0000 ~	4000	Word Address

Packet Transfer Mode

	Device	Word Address	Device code (HEX)	Address code
Word Device	Data Block	DB02W00000~	7C00	Same as word address value divided by 2
Bit Device	Input Relay	IW00000~	8000	Same as word address value divided by 2
	Output Relay	OW00000~	8800	Same as word address value divided by 2
	Internal Memory	Mw00000~	9000	Same as word address value divided by 2



A 3 Device Monitor

Using the GP's device monitor function allows the PLC's arbitrary device memory to be monitored or changed. A device can be monitored or changed from the GP window regardless of the GP screen being displayed.

- All applicable devices used with the GP can be monitored or changed by the GP.
- I/O relays, data memory and other items can be displayed on the Device Monitor function's special window in random or block format.
- The bit device's ON/OFF status, and the word device's current numeric values (selectable as binary, octal, decimal or hexadecimal) can be displayed.

Applicable GPs:

GP-2400, GP-2500, GP-2600, GP-477R, GP-577R, GP-377R, GP-470, GP-570, GP-571, GP-675, GP-370, GP-377, GP-H70 (System version 1.20 and later)

Applicable PLCs:

MELSEC-A series (CPU: A2A or A3A) direct CPU connection, by Mitsubishi Electric Co.

MELSEC-AnA series using Link I/F (applicable CPUs are listed in Section 1-3 "Connectable PLCs") link, by Mitsubishi Electric Co.

MELSEC-AnN series CPU Direct Connection (applicable CPUs are listed in Section 1-3 "Connectable PLCs") direct CPU connection, by Mitsubishi Electric Co.

MELSEC-AnN series using Link I/F (applicable CPUs are listed in Section 1-3 "Connectable PLCs") link, by Mitsubishi Electric Co.

MELSEC-QnA series CPU Direct Connection (applicable CPUs are listed in Section 1-3 "Connectable PLCs") direct CPU connected, by Mitsubishi Electric Co.

MELSEC-QnA series using Link I/F (applicable CPUs are listed in Section 1-3 "Connectable PLCs") link, by Mitsubishi Electric Co.

MELSEC-FX series (applicable CPUs are listed in Section 1-3 "Connectable PLCs"), by Mitsubishi Electric Co.

MELSEC-Q series CPU Direct Connection (applicable CPUs are listed in Section 1-3 "Connectable PLCs") direct CPU connected, by Mitsubishi Electric Co.

SYSMAC C Series (applicable CPUs are listed in Section 1-3 "Connectable PLCs")

SYSMAC a Series (applicable CPUs are listed in Section 1-3 "Connectable PLCs")

SYSMAC CS1 Series (applicable CPUs are listed in Section 1-3 "Connectable PLCs")

Reference To use the device monitor function, it must first be registered, using the GP-PRO/PBIII for Windows 95 software's Utility menu. (See Operation Manual's chapter 4.2.5 "Device Monitor".)

This chapter explains the use of this function with a MELSEC-A series PLC, manufactured by Mitsubishi Electric Co.



- **The device monitor function uses approximately 90 reserved tags. Therefore, when the device monitor's special screen is displayed on the GP monitor, the total number of tags displayed may exceed the maximum number allowed. In this case, the device monitor may not operate correctly. (The message "Number of tags exceeded" will be displayed) at the bottom of the screen. If using the device monitor exceeds the maximum number of tags, do not use the device monitor with that screen.**
- **It is possible in the interest of future expansion, to set a device address range which is outside the PLC's present device address range. However, when an attempt is made to display a non-existing range, the message "Host communication error" will be displayed. In this case, either adjust the device address range so it is inside the actual range, or delete it. Also, if a device address was written to outside the actual range, the message "Host communication error" will continue to be displayed. To erase this message, turn the GP's power OFF, and then ON again, or reset the GP while it is offline. Never try to write to device address that are outside of the PLC's actual range.**
- **The device monitor can only monitor devices that are shown in "Supported Devices" section in each PLC.**
- **User's Area from LS2096 to LS4095 will be reserved and cannot be used when using device monitor.**

■ Global Window Setup

The device monitor function uses the GP's global window function. This means that when the device monitor function is used, other global windows cannot be displayed.

With the GP in OFFLINE mode, select [1. INITIALIZE], then [1. SYSTEM ENVIRONMENT SETTINGS], and then [3. GLOBAL WINDOW SETUP]. In this window, input the following:

- Global window: Use
- Global window designation: Indirect
- Data format: BIN

A 3.1 Functions

(1) The Random Monitor can

- Monitor devices at eight arbitrary points.
- Designate bit and word devices monitored in single-bit units.
- Display the ON/OFF status for bit devices; display data in binary, octal, decimal, or hexadecimal notation for word devices.
- Write data to devices being monitored.

(2) The Block Monitor can

- Monitor devices at eight consecutive points.
- Specify the word device.
- Display data in binary, octal, decimal, or hexadecimal notation.
- Monitor devices in 8 point “pages”, (8 devices equal one page). Uses [NEXT] and [Previous] commands to move to next “page”.
- Specify the first device to be monitored.
- Write data to devices being monitored.

(3) To Write Data

- Write out the data for arbitrary devices regardless of the monitoring screen being used.
- Specify the bit device and word device.
- Change the ON/OFF status for bit devices, or input hexadecimal numeric values for the word device.



If any device monitor compatible with the MELSEC-FX made by Mitsubishi Electric Corp. is used, only the lower two bytes (16 bits) are displayed for any binary or octal number when a 32-bit device (CN200 to CN255) is monitored. For any hexadecimal or decimal number, all 32 bits are displayed.

A 3.2 Screen Operation

A 3.2.1 Starting Device Monitor

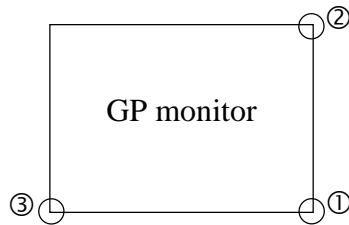

- 1) Touch the points shown by numbers ① and ②, then touch ③.

Reference For details refer to "I/O setup" in each unit's User's Manual.

Panel's Menu Bar will appear.

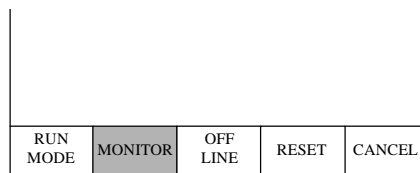

- 2) Select MONITOR from the menu bar.

The MONITOR MENU screen is then displayed. *1

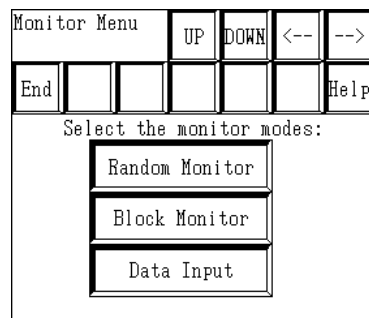

Important

If MONITOR is not displayed in the menu bar, check that the global window setting save correct.

Reference See "Global Window Settings".

*1 If the device monitor function is not supported by the protocol, touching the MONITOR selection has no effect.

A3.2.2 Monitor Menu

This menu can be used to monitor each PLC device.

In this window, please select the device monitor mode.

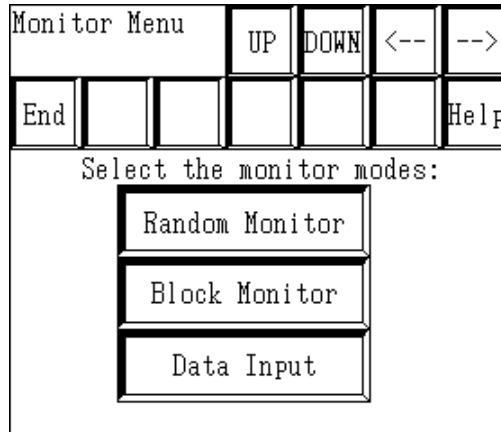

Monitors devices at eight arbitrary points.

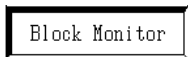

Monitors devices at eight consecutive points.

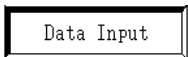

Writes data to an arbitrary device.



Changes the position of the device monitor's display window.



Ends Device Monitoring.

■ Random Monitor

Monitors devices at eight arbitrary points.

Random Monitor			UP	DOWN	<--	-->
Menu	CHG	INP	DISP	DEL		
1	D0100				0000h	
2	D0120				0000h	
3	D0140				0000h	
4	D0160				0000h	
5	D0180				0000h	
6	D0200				0000h	
7	D0000				0000h	
8	D6550				0000h	

└───┬───┘ Device name
 └───┘ Data
└───┘ Line number



Moves the position of the display window.



Returns to the MONITOR MENU.



Displays the title “Change Line Selection” and then changes to device and address change mode.



Displays the title “Write Line Selection” and then changes to data write mode.



Displays the title “Display Line Selection” and then changes to data display mode.



Displays the title “Delete Line Selection” and then deletes the Device data displayed at the selected line number.

Monitor Menu			UP	DOWN	<--	-->
End						Help
Select the monitor modes:						
<div style="border: 1px solid black; padding: 2px; margin-bottom: 5px;">Random Monitor</div> <div style="border: 1px solid black; padding: 2px; margin-bottom: 5px;">Block Monitor</div> <div style="border: 1px solid black; padding: 2px;">Data Input</div>						

1) Select RANDOM MONITOR from the MONITOR MENU.

Random Monitor			UP	DOWN	<--	-->
Menu	CHG	INP	DISP	DEL		
1	D0100				0000h	
2	D0120				0000h	
3	D0140				0000h	
4	D0160				0000h	
5	D0180				0000h	
6	D0200				0000h	
7	D0000				0000h	
8	D6550				0000h	

2) The RANDOM MONITOR screen will appear.

① Change

Both the device to be monitored and its address can be changed.

Random Monitor		UP	DOWN	<--	-->
Menu	CHG	INP	DISP	DEL	
1	D0100				0000h
2	D0120				0000h
3	D0140				0000h
4	D0160				0000h
5	D0180				0000h
6	D0200				0000h
7	D0000				0000h
8	D6550				0000h

1) Select [CHG] on the RANDOM MONITOR screen, and the RANDOM MONITOR CHANGE LINE SELECTION screen will appear.

Random Monitor CHANGE		UP	DOWN	<--	-->
Menu					RET
Please select a line number					
1	2	3	4		
5	6	7	8		

2) Select the line number of the line to be changed, and the RANDOM MONITOR CHANGE screen will appear.



You can also make the selection directly on the RANDOM MONITOR screen by touching the device or address to be changed with your fingertip.

Random Monitor CHANGE		UP	DOWN	<--	-->
Menu					RET
Please select a Bit or Word Device					
Bit Device					
Word Device					

3) Select the device to be changed.

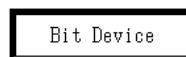

Select this when monitoring a bit device.



Select this when monitoring a word device.



Returns to the menu screen.



Returns to the previous screen.

When [BIT DEVICE] is selected:

Random Monitor CHANGE(Bit)		UP	DOWN	<--	-->
Menu				Next	RET
Please select a type of Bit Device					
X		Y		M	
M9 (Special Relay)		B		L	

- 4) Select the type of device to be monitored on the RANDOM MONITOR CHANGE screen.

Touch [NEXT] to display the remaining device types.

Random Monitor CHANGE(Bit)		UP	DOWN	<--	-->
Menu					RET
Please select a type of Bit Device					
TS		TC		CS	
CC		F			

When [WORD DEVICE] is selected:

Random Monitor CHANGE(Word)		UP	DOWN	<--	-->
Menu				Next	RET
Please select a type of Word Device					
X		Y		D	
W		R		F	

Touch [NEXT] to display the remaining device types.

Random Monitor CHANGE(Word)		UP	DOWN	<--	-->
Menu					RET
Please select a type of Word Device					
TN		CN			
M		M9 (Special Relay)			

- 5) Input the address of the device to be monitored, and touch [ENT].

The address of the device being monitored is then changed.

Random Monitor CHANGE(Bit)		UP	DOWN	<--	-->	
Menu					RET	
Type of Bit Device						
Please enter an address						
1	2	3	4	5	6	7
8	9	0	A	B	C	D
E	F	CL	ENT			



- The types of devices displayed will vary depending on the PLC being used.
- In anticipation of future expansion, the device address input can exceed the actual device address range of the PLC being used.

However, if an attempt is made to monitor an address outside the device address range, the message “PLC COM. ERROR” will be displayed at the bottom of the screen.

In such a case, adjust the device address range being monitored so that it is within the actual device address range of the PLC being used.

② Writing

Data can be written either to the device to be monitored or to its address.

Random Monitor				UP	DOWN	<--	-->
Menu	CHG	INP	DISP	DEL			
1	D0100					0000h	
2	D0120					0000h	
3	D0140					0000h	
4	D0160					0000h	
5	D0180					0000h	
6	D0200					0000h	
7	D0000					0000h	
8	D6550					0000h	

- 1) Select [WRITE] on the RANDOM MONITOR screen, and the RANDOM MONITOR WRITE LINE SELECTION screen will appear.

Block Monitor INPUT				UP	DOWN	<--	-->
Menu							RET
Please select a line number							
<input type="button" value="1"/>	<input type="button" value="2"/>	<input type="button" value="3"/>	<input type="button" value="4"/>				
<input type="button" value="5"/>	<input type="button" value="6"/>	<input type="button" value="7"/>	<input type="button" value="8"/>				

- 2) Select the line number of the device to be written to, and the RANDOM MONITOR WRITE screen will appear.



You can also make the selection directly on the RANDOM MONITOR screen by touching the device to be written to with your fingertip.

When the selected line's device is a bit device:

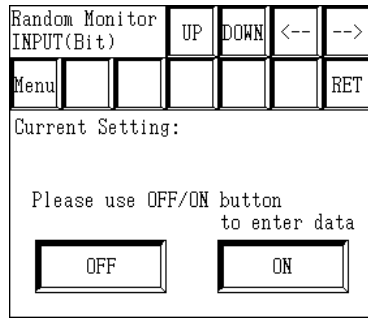

1) Select the data.



Turns the bit device OFF.



Turns the bit device ON.

When the selected line's device is a word device:

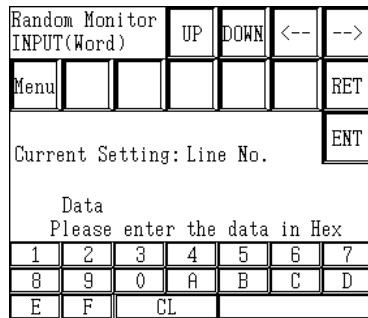

1) Input the data in hexadecimal, and touch [ENT].

The data will be written to the selected line's device.



Note: The position of the [ENT] key is different from that on the **RANDOM MONITOR CHANGE** screen. (This is to prevent the accidental writing of data.)

If input wrong, the message "Input error" will blink in the upper-left corner of the screen.

Reference For information about input ranges, refer to devices listed in "Supported Devices" section in each PLC.



Do not attempt to write address data to a device that is outside the actual device address range of the PLC being used.

③ Display format

Here, the data's display format can be selected. While a bit device is actually being monitored, however, the display format cannot be changed.

Random Monitor			UP	DOWN	<--	-->
Menu	CHG	INP	DISP	DEL		
1	D0100				0000h	
2	D0120				0000h	
3	D0140				0000h	
4	D0160				0000h	
5	D0180				0000h	
6	D0200				0000h	
7	D0000				0000h	
8	D6550				0000h	

1) Select [DISP] on the RANDOM MONITOR screen, and the RANDOM MONITOR DISPLAY LINE SELECTION screen will appear.

Random Monitor DISPLAY			UP	DOWN	<--	-->
Menu						RET
Please select a line number						
1	2	3	4			
5	6	7	8			

2) Select the line number of the line whose display format you wish to change, and the RANDOM MONITOR DISPLAY screen will appear.

Random Monitor DISPLAY			UP	DOWN	<--	-->
Menu						RET
Please select a data display format						
Bin		Oct				
Dec		Hex				

3) Select the data's display format.

④ Deleting

Here, a line of device data used for monitoring can be deleted.

Random Monitor				UP	DOWN	<--	-->
Menu	CHG	INP	DISP	DEL			
1	D0100					0000h	
2	D0120					0000h	
3	D0140					0000h	
4	D0160					0000h	
5	D0180					0000h	
6	D0200					0000h	
7	D0000					0000h	
8	D6550					0000h	

- 1) Select [DEL] on the RANDOM MONITOR screen, and the RANDOM MONITOR DELETE LINE SELECTION screen will appear.

Random Monitor DISPLAY				UP	DOWN	<--	-->
Menu							RET
Please select a line number							
1	2	3	4				
5	6	7	8				

- 2) Select the line number of the line you wish to delete, and the monitor of the selected line number will be deleted.

■ BLOCK MONITOR

Here, you can monitor up to eight consecutive word devices.

Block Monitor				UP	DOWN	<--	-->
Menu	CHG	INP	DSP		△	▽	
	D0100					0000h	
	D0120					0000h	
	D0140					0000h	
	D0160					0000h	
	D0180					0000h	
	D0200					0000h	
	D0000					0001h	



Moves the window's display position.



Returns to the MONITOR MENU screen.



Displays the CHANGE LINE SELECTION and then switches to the Device and Address Change mode.



Displays the WRITE LINE SELECTION screen, and then switches to the Data Write mode.



Displays the DISPLAY LINE SELECTION screen, and then switches to the Data Display mode.



Displays ("Pages" backwards to show) the previous 8 addresses.



Displays ("Pages" forwards to show) the next 8 addresses.

Monitor Menu				UP	DOWN	<--	-->
End							Help
Select the monitor modes:							
Random Monitor							
Block Monitor							
Data Input							

1) Select [BLOCK MONITOR] from the MONITOR MENU screen and then [BLOCK MONITOR] screen will be displayed.

Block Monitor				UP	DOWN	<--	-->
Menu	CHG	INP	DSP		△	▽	
	D0100					0000h	
	D0120					0000h	
	D0140					0000h	
	D0160					0000h	
	D0180					0000h	
	D0200					0000h	
	D0000					0000h	
	D6550					0000h	

2) Use the [CHG] key to select the device to be monitored.

① Change

Both the device to be monitored and its address can be changed. First, change the device and address where you will start monitoring.

Block Monitor				UP	DOWN	<--	-->
Menu	CHG	INP	DSP		△	▽	
	D0100						0000h
	D0120						0000h
	D0140						0000h
	D0160						0000h
	D0180						0000h
	D0200						0000h
	D0000						0000h
	D6550						0000h

- 1) Select [CHG] from the BLOCK MONITOR screen's menu, and the BLOCK MONITOR CHANGE screen will appear.

Block Monitor CHANGE				UP	DOWN	<--	-->
Menu					Next	RET	
Please select a type of device							
	X		Y			D	
	W		R			F	

- 2) Select the type of device to be changed.



Returns to the menu screen.



Returns to the previous screen.



Displays the remaining device types.

Block Monitor CHANGE				UP	DOWN	<--	-->
Menu							RET
Please select a type of device							
	TN					CN	
	M					M9	
(Special Relay)							

- 3) Input the address to be monitored and touch the [ENT] key.

Block Monitor CHANGE				UP	DOWN	<--	-->
Menu							RET
Type of Device							
Please enter an address							
1	2	3	4	5	6	7	
8	9	0	A	B	C	D	
E	F		CL			ENT	



In anticipation of future expansion, the device address input can exceed the actual device address range of the PLC being used.

However, if an attempt is made to monitor an address outside the device address range, the message "Host Communication Error" will be displayed at the bottom of the screen.

In such a case, adjust the device address range being monitored so that it is within the actual device address range of the PLC being used.

② Writing

Data can be written to either the device being monitored or to its address.

Block Monitor				UP	DOWN	<--	-->
Menu	CHG	INP	DSP		△	▽	
	D0100					0000h	
	D0120					0000h	
	D0140					0000h	
	D0160					0000h	
	D0180					0000h	
	D0200					0000h	
	D0000					0000h	
	D6550					0000h	

1) Select [INP] on the BLOCK MONITOR screen, and the BLOCK MONITOR INPUT LINE SELECTION screen will appear.

Block Monitor INPUT				UP	DOWN	<--	-->
Menu							RET
Please select a line number							
	1	2	3	4			
	5	6	7	8			

2) Select the line number of the device to be written to, and the BLOCK MONITOR INPUT screen will appear.



You can also make the selection directly on the BLOCK MONITOR screen by touching the device to be written to with your fingertip.

Block Monitor INPUT				UP	DOWN	<--	-->
Menu							RET
Current Setting:							ENT
Data Please enter the data in Hex							
1	2	3	4	5	6	7	
8	9	0	A	B	C	D	
E	F	CL					

3) Input the data in hexadecimal, and touch [ENT].

The data will be written to the selected line's device.



The position of the [ENT] key is different from that on the BLOCK MONITOR CHANGE screen. (This is to prevent the accidental writing of data.)

If input wrong, the message "Input error" will blink in the upper-left part of the screen.

Reference For information about input ranges, refer to devices listed in "Supported Devices" section in each PLC.



Do not attempt to write address data to a device that is outside the actual device address range of the PLC being used.

③ Display format

Here, the data's display format can be selected.

Block Monitor				UP	DOWN	<--	-->
Menu	CHG	INP	DSP		△	▽	
	D0100						0000h
	D0120						0000h
	D0140						0000h
	D0160						0000h
	D0180						0000h
	D0200						0000h
	D0000						0000h
	D6550						0000h

1) Select [DISP] on the BLOCK MONITOR screen and the BLOCK MONITOR DISPLAY screen will appear.

Block Monitor DISPLAY				UP	DOWN	<--	-->
Menu							RET
Please select a data display format							
Bin		Oct					
Dec		Hex					

2) Select the data's display format.

A 3.2.3 Writing Data

Here, data can be written to the PLC's arbitrary (designated) device.



Do not attempt to write address data to a device that is outside the actual device address range of the PLC being used.

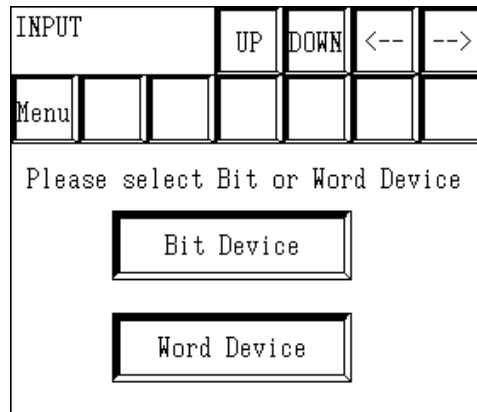

Select this when writing to a bit device.

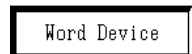

Select this when writing to a word device.



Moves the window's display position.



Returns to the menu screen.

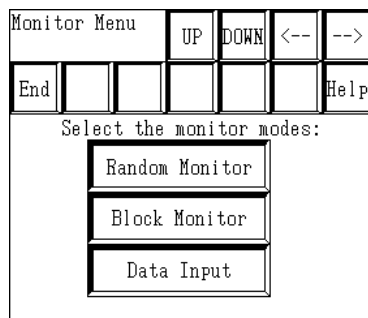

1) Select [Data Input] on the MONITOR MENU screen, and the WRITE screen will appear.

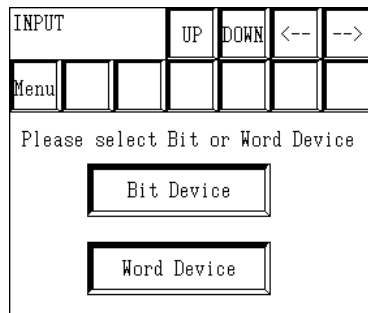

2) Select the (bit or word) device to be changed.

The following section explains the procedures used when either a bit or word device is selected.

When [BIT DEVICE] is selected:

INPUT	Bit Select	UP	DOWN	<--	-->
Menu				Next	RET

Please select a type of device

X	Y	M
MR	B	L

(Special Relay)

3) Select the type of the device to be written to.

Touching [NEXT] displays the remaining device types.

INPUT	Bit Select	UP	DOWN	<--	-->
Menu					RET

Please select a type of Bit Device

TS	TC	CS
CC	F	

4) Input the address of the device to be written to, and touch [ENT].

INPUT	Bit Select	UP	DOWN	<--	-->
Menu					RET

Type of Device

Please enter an address

1	2	3	4	5	6	7
8	9	0	A	B	C	D
E	F	CL			ENT	



In anticipation of future expansion, the device address input can exceed the actual device address range of the PLC being used.

However, if an attempt is made to monitor an address outside the device address range, the message "Host Communication Error" will be displayed at the bottom of the screen.

In such a case, adjust the device address range being monitored so that it is within the actual device address range of the PLC being used.

INPUT	Bit Select	UP	DOWN	<--	-->
Menu					RET

Type of Device

Please use OFF/ON button to enter data

OFF	ON
-----	----

5) Input the data to be written to the PLC bit address.

OFF

Turns the bit OFF.

ON

Turns the bit ON.

If input wrong, the message "Input error" will blink in the upper-left corner of the screen.

Reference For information about input ranges, refer to devices listed in "Supported Devices" section in each PLC.

When [WORD DEVICE] is selected:

INPUT	Word Select	UP	DOWN	<--	-->
Menu				Next	RET

Please select a type of device

X	Y	D
W	R	F

3) Select the type of the device to be written to.

Touching [NEXT] displays the remaining device types.

INPUT	Word Select	UP	DOWN	<--	-->
Menu					RET

Please select a type of Word Device

TN	CN
M	M9

(Special Relay)

4) Input the address of the device to be written to, and touch [ENT].

INPUT	Word Select	UP	DOWN	<--	-->
Menu					RET

Type of Device D 000000

Please enter an address

1	2	3	4	5	6	7
8	9	0	A	B	C	D
E	F	CL	ENT			

If input wrong, the message "Input error" will blink in the upper-left corner of the screen.

Reference For information about input ranges, refer to devices listed in "Supported Devices" section in each PLC.

INPUT	Word Select	UP	DOWN	<--	-->
Menu					RET

Type of Device

Please enter an address

1	2	3	4	5	6	7
8	9	0	A	B	C	D
E	F	CL	ENT			

5) Input the data to be written to the PLC word address and touch [ENT].



Note: The position of the [ENT] key is different from that on the RANDOM MONITOR CHANGE screen. (This is to prevent the accidental writing of data.)

