

**GP-PRO/PBIII for Windows
Device/PLC CONNECTION MANUAL**

ADDITIONAL MANUAL

**Rockwell (Allen-Bradley)
Control Logix 5000 Series
(Ethernet)**

Reading the GP-PRO/PBIII Device/PLC Connection Manual

This document is designed as an addition to the latest GP-PRO/PBIII for Windows Device/PLC Connection manual's Rockwell (Allen-Bradley)'s Control Logix 5000 Series (Ethernet) data.

When connecting a Factory Gateway unit, please substitute the words "Factory Gateway" for the words "GP/GLC".

Installation

This CD-ROM includes all the protocol files required by the GP/GLC to communicate with an Allen-Bradley (Rockwell)'s PLC. Also, you will need to have one or more of the following software applications installed, the screen and data transfer file included in the CD-ROM must be installed in each of those applications. For information about the installation of the software, refer to that software's Operation Manual.

■ Software Applications

- GP-PRO/PBIII for Windows Ver. 6.1 or later
- Pro-Server with Pro-Studio for Windows Ver. 4.1 or later ^{*1}

- 1) Be sure to confirm that GP-PRO/PBIII for Windows is installed in your PC prior to starting this driver installation.
- 2) To install the new driver, double-click on "ABCL_EIP.exe" when using a Control Logix 5000 Series unit Ethernet connection.
- 3) Once the installation program starts, follow the instructions given to install the protocol files.



When using the Control Logix 5000 Series unit Ethernet protocol , select [Others] - [AB Control Logix (ETHER/IP)] for the " Device/PLC Type" .

***1 When using the Factory Gateway unit, GP-Web Ver.1.0 or later or GP-Viewer Ver.1.0 or later, be sure to select Pro-Server with Pro-Studio for Windows as the "Destination Folder".**

7.8 Rockwell (Allen-Bradley)

7.8.1 System Structure for Ethernet Connection

This section explains the system structures available for the Ethernet connection between Rockwell (Allen-Bradley) PLCs and GP/GLC units.

■ SLC500 Series

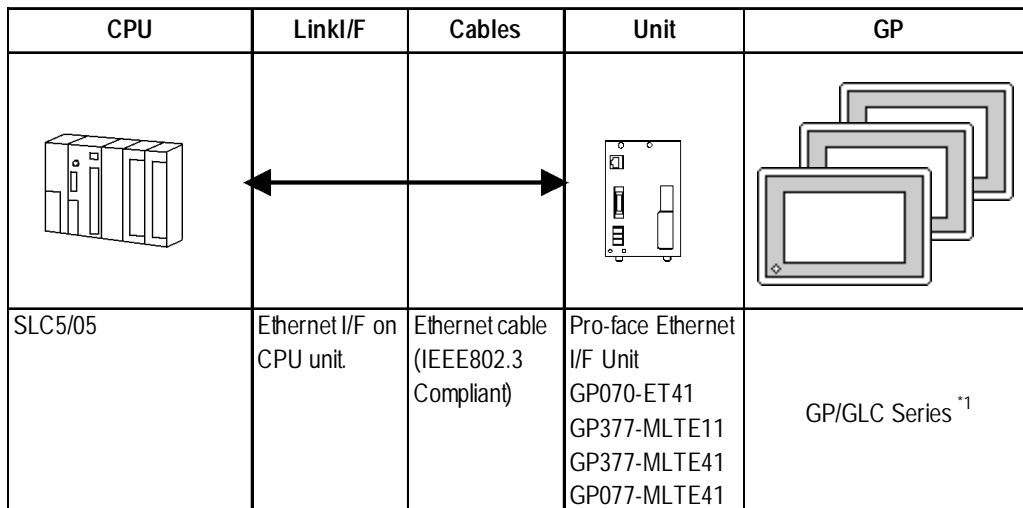

*1 When using GP/GLC and the optional Ethernet I/F unit, refer to the following List of Connectable GP/GLC Units.

Series Name		Product Name	Optional Ethernet I/F Unit	Built-in Ethernet Port
GP77R Series	GP-377R Series	GP-377RT	○ ^{*1*2}	x
	GP-477R Series	GP-477RE	○ ^{*2}	x
	GP-577R Series	GP-577RS	○ ^{*2}	x
		GP-577RT	○ ^{*2}	x
GP2000 Series	GP-2300 Series	GP-2300L	x	○
		GP-2300T	x	○
	GP-2400 Series	GP-2400T	x	○
	GP-2500 Series	GP-2500L	○ ^{*3*4}	○
		GP-2500S	○ ^{*3*4}	○
		GP-2500T	○ ^{*3*4}	○
	GP-2501 Series	GP-2501S	○ ^{*2*3}	x
		GP-2501T	○ ^{*2*3}	x
GP-2600 Series	GP-2600T	○ ^{*3*4}	○	
GLC2000 Series	GLC-2300 Series	GLC-2300L	x	○
		GLC-2300T	x	○
	GLC-2400 Series	GLC-2400T	x	○
	GLC-2600 Series	GLC-2600T	○ ^{*3*4}	○

*1 Only the Multi Unit can be used.

*2 The 2-Way Driver (Pro-Server, GP-Web and others) cannot be used.

- *3 When using the optional Ethernet I/F unit, a bus conversion unit (PSL-CONV000) is required.
- *4 Using the optional Ethernet I/F Unit allows you to set up separate Class and Net No.s for 2-Way Driver applications (Pro-Server, GP-Web and others) and the PLC. When doing this, data transfer with the PLC is performed through the optional Ethernet I/F Unit.



- For cable connection and Optional Unit information, refer to the User Manual for each optional unit. For GP2000 and GLC2000 series units, refer to that unit's User Manual.

◆ Connection Structure

<1 : 1 connection>

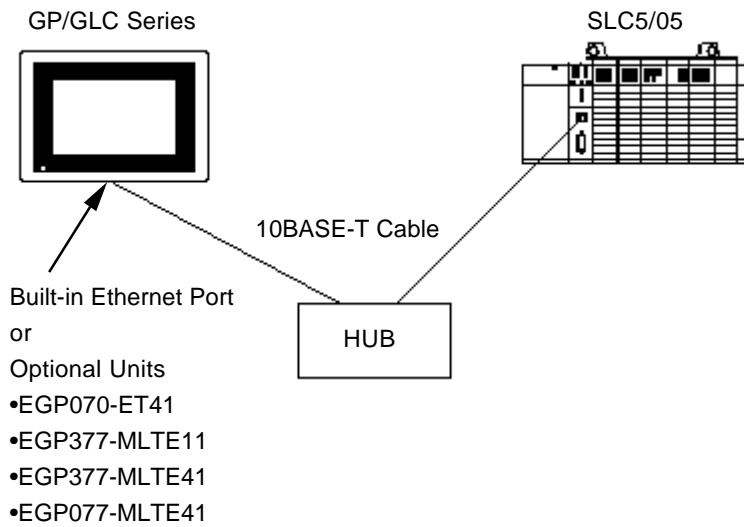

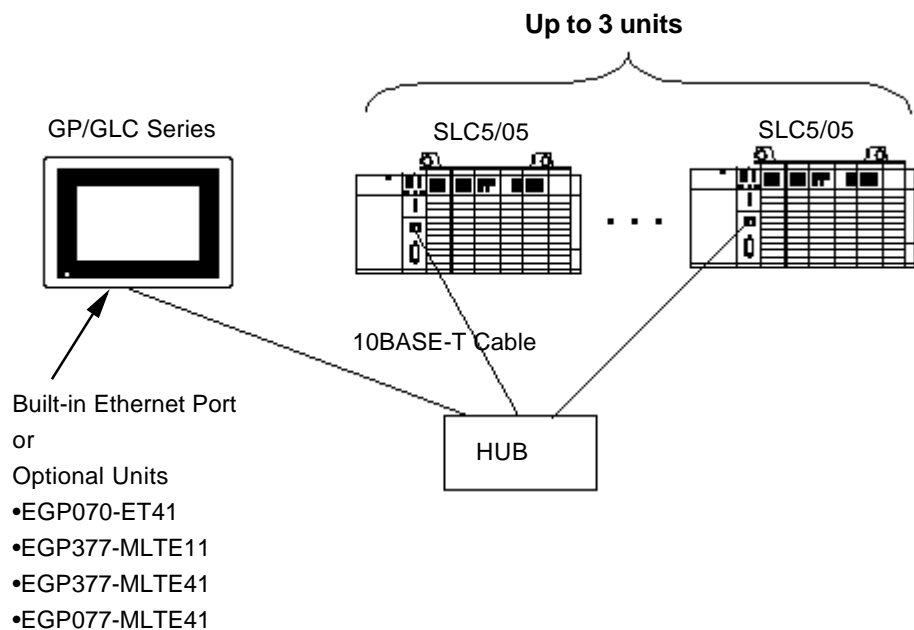

<1:n connection>

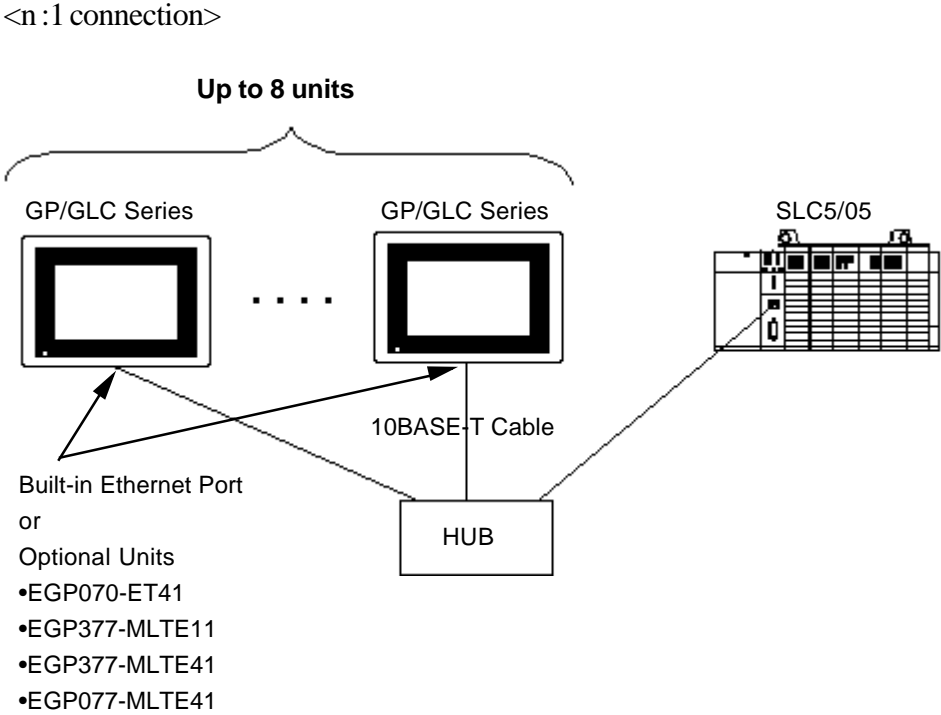

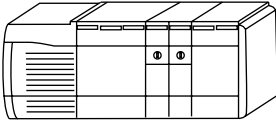

■ Control Logix 5000 Series

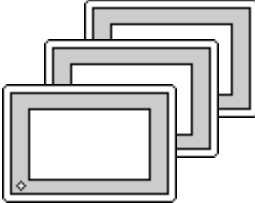
CPU	LinkI/F	Cables	GP
			
1756-L1 1756-L1M1 1756-L1M2 1756-L1M3 1756-L55M13 1756-L55M14 1756-L55M16	1756-ENET 1756-ENBT	Ethernet cable (IEEE802.3 Compliant)	GP/GLC Series *1

*1 Refer to the following List of Connectable GP/GLC Units.

Series Name		Product Name
GP2000 Series	GP-2300 Series	GP-2300L
		GP-2300T
	GP-2400 Series	GP-2400T
	GP-2500 Series	GP-2500L
		GP-2500S
	GP-2500T	
	GP-2600 Series	GP-2600T
GLC2000 Series	GLC-2300 Series	GLC-2300L
		GLC-2300T
	GLC-2400 Series	GLC-2400T
	GLC-2600 Series	GLC-2600T

 **Note:** • Optional Ethernet I/F Unit cannot be used.

◆ Connection Structure

<1 : 1 connection>

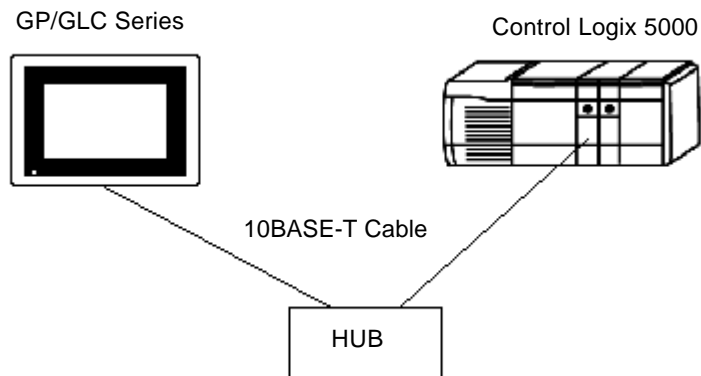

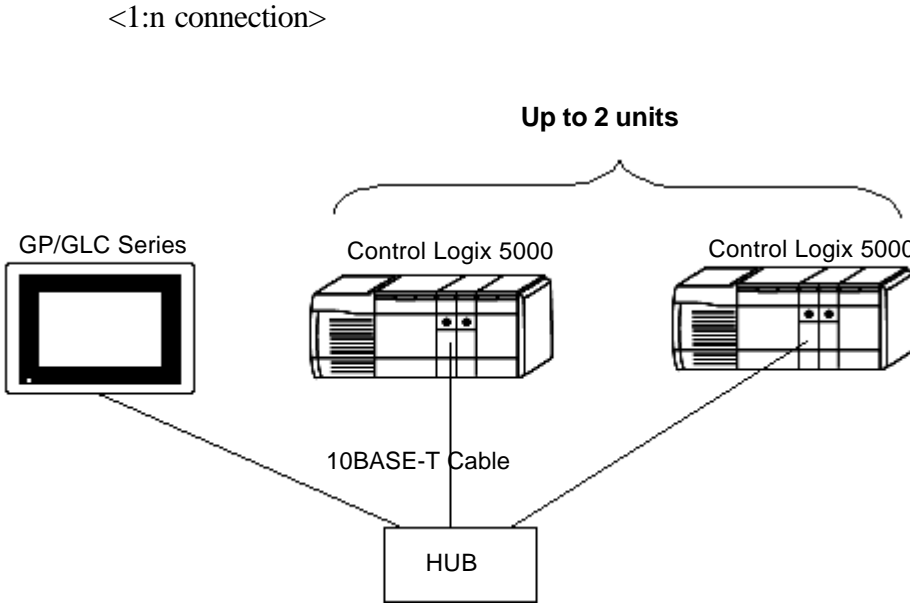
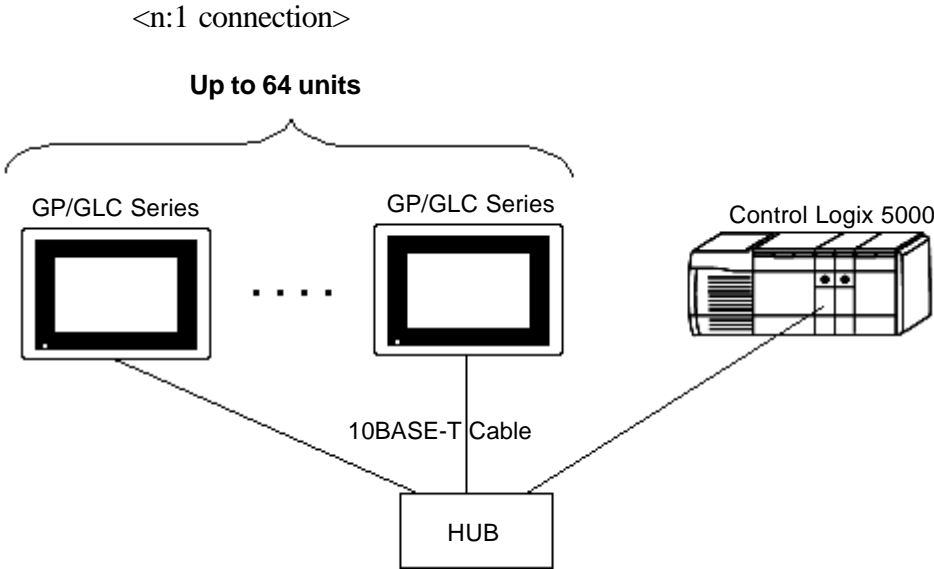

7.8.2 Supported Devices

The following list shows the range of devices supported by the GP/GLC.

■ **SLC500 Series**

 Setup System Area here.

Device	Bit Address	Word Address	Others
Bit	B3:0/0 - B3:255/15 B9:0/0 - B255:255/15	B3:0 - B3:255 B9:0 - B255:255	H/L
Timer (TT : Timing Bit)	T4:0/TT - T4:255/TT T9:0/TT - T255:255/TT	-	L/H
Timer (DN : Complete Bit)	T4:0/DN - T4:255/DN T9:0/DN - T255:255/DN	-	
Timer (EN : Enable)	T4:0/EN - T4:255/EN T9:0/EN - T255:255/EN	-	
Timer (PRE : Setup Value)	-	T4:0.PRE - TP4:255.PRE T9:0.PRE - T255:255.PRE	
Timer (ACC : Current Value)	-	T4:0.ACC - T4:255.ACC T9:0.ACC - T255:255.ACC	
Counter (CU :Up Count)	C5:0/CU - C5:255/CU C9:0/CU - C255:255/CU	-	
Counter (CD : Down Count)	C5:0/CD - C5:255/CD C9:0/CD - C255:255/CD	-	
Counter (DN : Complete Bit)	C5:0/DN - C5:255/DN C9:0/DN - C255:255/DN	-	
Counter (OV : Overflow)	C5:0/OV - C5:255/OV C9:0/OV - C255:255/OV	-	
Counter (UN : Underflow)	C5:0/UN - C5:255/UN C9:0/UN - C255:255/UN	-	
Counter (UA : Update)	C5:0/UA - C5:255/UA C9:0/UA - C255:255/UA	-	
Counter (PRE : Setup Value)	-	C5:0.PRE - C5:255.PRE C9:0.PRE - C255:255.PRE	
Counter (ACC :Current Value)	-	C5:0.ACC - C5:255.ACC C9:0.ACC - C255:255.ACC	
Control (DN : Complete Bit)	R6:0/DN - R6:255/DN R9:0/DN - R255:255/DN	-	
Control (EN :Enable)	R6:0/EN - R6:255/EN R9:0/EN - R255:255/EN	-	
Control (ER : Error)	R6:0/ER - R6:255/ER R9:0/ER - R255:255/ER	-	
Control (UL : Unload)	R6:0/UL - R6:255/UL R9:0/UL - R255:255/UL	-	
Control (IN : In High Bit)	R6:0/IN - R6:255/IN R9:0/IN - R255:255/IN	-	
Control (FD : Found)	R6:0/FD - R6:255/FD R9:0/FD - R255:255/FD	-	
Control (EU : Unload Enabled)	R6:0/EU - R6:255/EU R9:0/EU - R255:255/EU	-	
Control (EM: Empty Slack)	R6:0/EM - R6:255/EM R9:0/EM - R255:255/EM	-	
Control (LEN : Length)	-	R6:0.LEN - R6:255.LEN R9:0.LEN - R255:255.LEN	
Control (POS : Position)	-	R6:0.POS - R6:255.POS R9:0.POS - R255:255.POS	
Integer	-	N7:0 - N7:255 N9:0 - N255:255	H/L
Floating Decimal Point	-	F8:0 - F255:255	L/H



Important

When using Pro-Server with Pro-Studio:

- **To access any of the above devices, Pro-Server with Pro-Studio Ver. 4.1 or higher is required. Also, additional settings are required. For setting details. please refer to the Pro-Server with Pro-Studio Ver. 4.1 or higher software's Operation Manual.**
- **Using versions prior to Pro-Server with Pro-Studio Ver. 4.1 allows you to only accessthe LS Area.**

◆ When setting Parts or Tags from GP-PRO/PBIII for Windows

Before setting up Parts or Tags, Network Information settings must be entered. Network Information settings can be entered from the [GP SYSTEM SETTING]->[MODE SETTING]->[Network Information] screen.

▼ **Reference** ▲ this manual, 7.8.3 Environment Setup

Setting up Parts or Tags by specifying the PLC's Node Address allows the specified PLC's Device data to be read out.

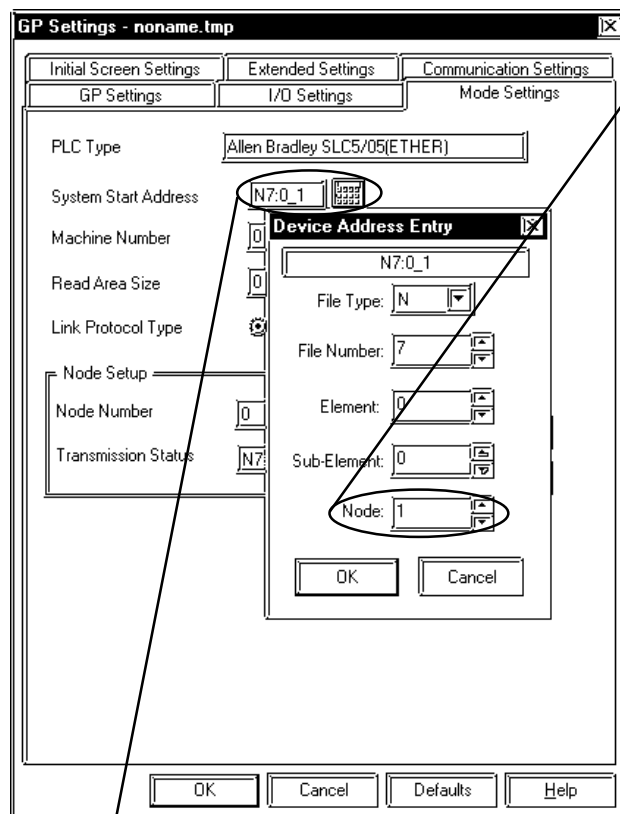

The System Area and Read Area are assigned to the PLC node designated here. Node Numbers are set via the [Mode Settings] - [Network Information] screen.

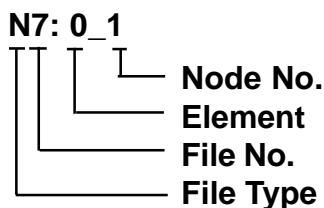



Note: • Rockwell (Allen-Bradley) PLC device data consists of elements. When entering devices and addresses in GP-PRO/PBIII for Windows, use the following method.

- When using Word Devices N, B or F

(Display after entry)

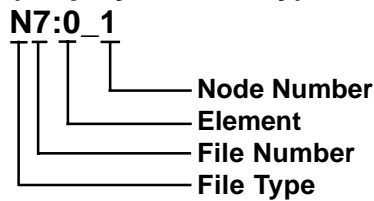

- When using Word Devices T, C or R

(Display after entry)

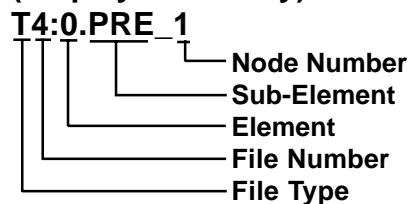

- When using Word Devices N or B

(Display after entry)

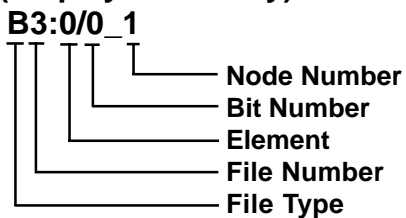

- When using Bit Devices T, C or R

(Display after entry)

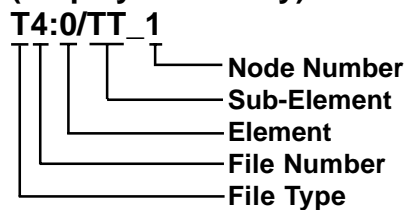

■ SLC500 Series Ethernet Protocol Limitation

Even though the SLC500 Series Ethernet Protocol can access more than one CPU, the following limitations apply.

1. Device Address and Node Number Limitations

When a different File Number or Node Number is set, the number of available device addresses will vary. The GP uses internal records to set the device addresses. These records are limited to 64. For example, when the N7:0 device address is set, a single record is used in the GP. For detailed examples, refer to the following chart.

Ex1.) Number of records used when designating tag setting numbers.

Setting No.	Node No.	Device Address	Remaining Number of records in GP-PRO/PBIII	Remarks
1	1	N7:0	63	Uses one record
2	1	N9:0	62	Uses one record
3	2	B10:0	61	Uses one record
4	2	B11:0	60	Uses one record
5	1	N7:255	60	Since the node number and element number range already exist as setting No.1, no records will be used.
6	2	B10:255	60	Since the node number and element number range already exist as setting No.3, no records will be used.
7	3	N12:0	58	Uses one record

When using a different Node Number or File Number, GP internal records are used.

Ex2.) When setting tags from N10 to N19 (File Number), a total of 10 records will be used. Therefore, when setting tags continuously from N10 (File Number), File Numbers can be used up to N73.



When the number of records exceeds 65, the following error message will appear on the GP Screen Editor software (GP-PRO/PBIII for Windows).

“Address entry limit reached. No more can be entered”

■ Control Logix 5000 Series

Setup System Area here.

Device	Bit Address	Word Address	Remarks
Bit (BOOL)	BOOL00000000-BOOL99999931	BOOL000000-BOOL999999	*1*3
8 bit integer (SINT)	_____	SINT000000-SINT999998	Bit 7 ÷ 2 *1
16 bit integer (INT)	_____	INT000000-INT999999	Bit 15 *1
32 bit integer (DINT)	_____	DINT000000-DINT999999	Bit 32 *1
32 bit float (REAL)	_____	REAL000000-REAL999999	*1*2 H/L

*1 When using a GP Series unit to access a ControlLogix 5000 Series unit's data memory, you must first allocate data memory's array elements.

▼ **Reference** ▲ ◆ Device Setting Example (P.7-8-14)

When allocating array elements, use File numbers and Element numbers. An address designation example is shown below for GP-PRO/PBIII for Windows.

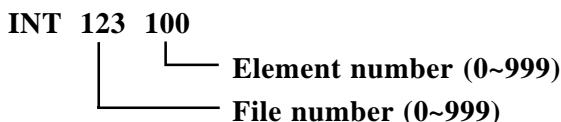

*2 This device uses Float. When this type of device is used, only the E-tag and K-tag's "32-bit Float" setting can be used.

*3 The BOOL device descriptions used in the GP-PRO/PBIII manual and the RSLogix 5000 manual are different. Please be aware of these differences when setting up BOOL devices.

GP-PRO/PBIII manual	0:0/00-0:00/31	0:1/00-0:1/31	0:2/00-0:2/31	~	0:999/00-0:999/31
RSLogix 5000 manual	0-31	32-63	64-95	~	31968-31999



- **When using the GP to access a PLC device, be sure to first allocate all Tags used by PLC Data Memory to their respective devices. Use the Rockwell's RSLogix 5000 ladder logic software to allocate these devices.**

If device allocation is not performed, a Host Communication Error will occur (02:D6).

▼ **Reference** ▲ 7.8.5 Error Codes

- **When using Pro-Server with Pro-Studio:**
 - To access any of the above devices, Pro-Server with Pro-Studio Ver. 4.1 or higher is required. Also, additional settings are required. For setting details, please refer to the Pro-Server with Pro-Studio Ver. 4.1 or higher software's Operation Manual.
 - Using versions prior to Pro-Server with Pro-Studio Ver. 4.1 allows you to only access the LS Area.

◆ **When setting Parts or Tags from GP-PRO/PBIII for Windows**

Before setting up Parts or Tags, Network Information settings must be entered. Network Information settings can be entered from the [GP SYSTEM SETTING]->[MODE SETTING]->[Network Information] screen.

▼ **Reference** ▲ *this manual, 7.8.3 Environment Setup*

Setting up Parts or Tags by specifying the PLC's Node Address allows the specified PLC's Device data to be read out.

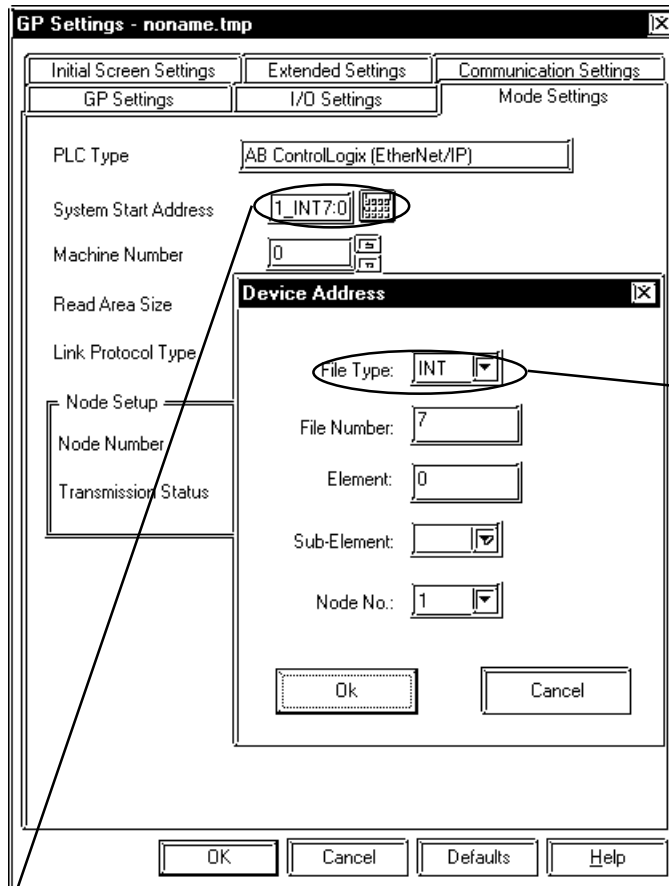

The system start address is allocated to the IP Address PLC designated in the Node Number. Node Numbers are set via the [Mode Settings] - [Network Information] screen.

(Display after entry)

1_INT7:0

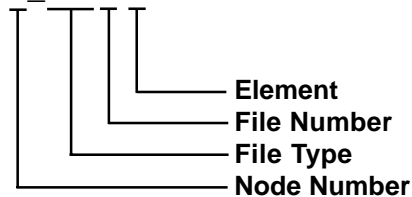



Note: Device Data in a PLC is organized using Elements. Enter the device and address settings as follows.

• When using Word Device

(Display after entry)

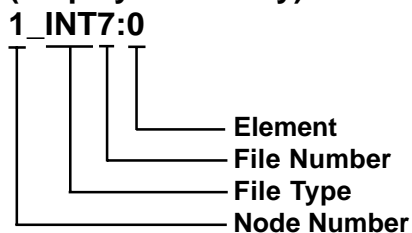

• When using Bit Device

(Display after entry)

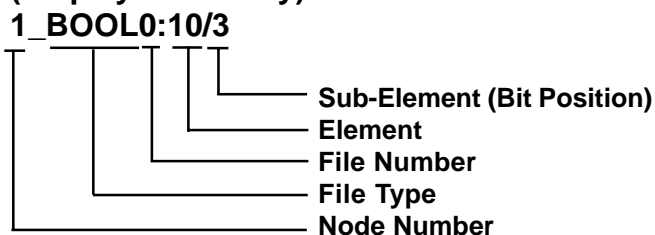

◆ Device Setting Example

The following explanation is for the ControlLogix 5000 device allocation.

1) PLC Tag Settings

Designate the Tag Name and Type.

- Tag Name : Can be set to any value. (Not related to GP device name)
- Type : Use one of the following data types for the Element setting.

(Use the same device name as the GP)

BOOL (32-bit data type)

INT (word data type)

DINT (dword data type)

SINT (byte data type)

REAL (float data type)

Example 1

Tag Name	Type
N7	INT[200]
DINT1	DINT[100]
DATA2	SINT[50]

This example's data uses the following values.

Row1 : Tag Name "N7" uses the INT data type for a 200 element array.

Row2 : Tag Name "DINT1" uses the DINT data type for a 100 element array.

Row3 : Tag Name "DATA2" uses the SINT data type for a 50 element array.

Be sure to set the number of array elements within the GP unit's maximum usable range. (The GP can access up to 999 elements.)

Also, if array elements are not designated, only one element can be used.

Ex. Tag Name:N8, Type:INT allows only one word to be used by N8.

2) Mapping Settings

The tag name set in 1) can have any desired file number allocated to it. It is not possible to set the same file number to two tag names.

Example 2

File Number	Tag Number
2	DATA2
1	DINT1
7	N7

■ Control Logix 5000 Series Ethernet Protocol Limitation

Even though the Control Logix 5000 Series Ethernet Protocol can access more than one CPU, the following limitations apply.

1. Device Address and Node Number Limitations

When a different File Number or Node Number is set, the number of available device addresses will vary. The GP uses internal records to set the device addresses. These records are limited to 64. For example, when the N7:0 device address is set, a single record is used in the GP. For detailed examples, refer to the following chart.

Example 1 - Number of records used when designating tag setting numbers.

Setting No.	Device Address	Remaining Number of records in GP-PRO/PBIII	Remarks
1	INT7:0	63	Uses one record
2	INT9:0	62	Uses one record
3	BOOL10:0	61	Uses one record
4	BOOL11:0	60	Uses one record
5	INT7:255	60	Since the element number range already exists as setting No.1, no records will be used.
6	BOOL10:255	60	Since the element number range already exists as setting No.3, no records will be used.
7	INT12:0	59	Uses one record

When using a different File Number, GP internal records are used.

Example 2 - When setting tags from N10 to N19 (File Number), a total of 10 records will be used. Therefore, when setting tags continuously from N10 (File Number), File Numbers can be used up to N73.



When the number of records is over 65, the following error message will appear on the GP Screen Editor software (GP-PRO/PBIII for Windows).

“Address entry limit reached. No more can be entried”

7.8.3 Environment Setup

■GP Settings

The following screens show the GP's communication settings, which are required for communication via an Ethernet Network:

◆SET UP OPERATION SURROUNDINGS MENU

<GP-477R/GP-577R/GP-2400/GP-2500/GP-2501/GP-2600/GLC2400/GLC2600 Series>

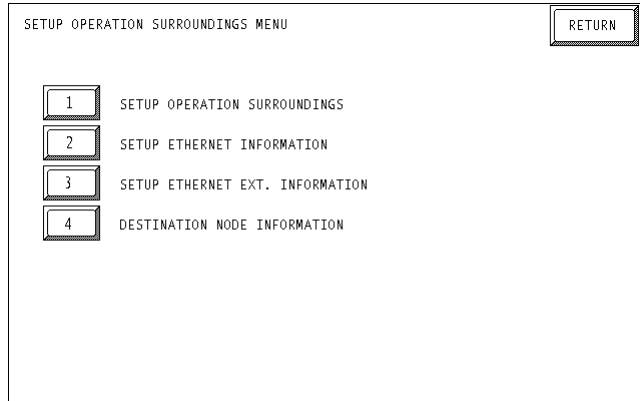

<GP-377R/GP-2300/GLC2300 Series>

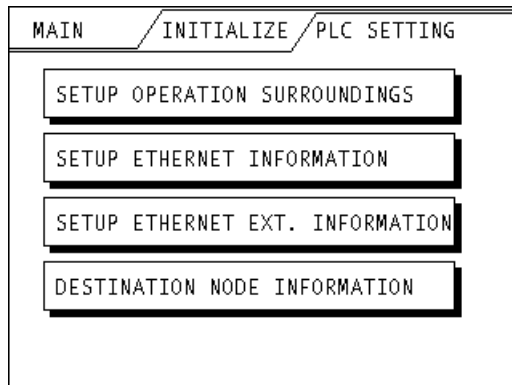

• SET UP OPERATION SURROUNDINGS

<<GP-477R/GP-577R/GP-2400/GP-2500/GP-2501/GP-2600/GLC2400/GLC2600Series>

SET UP OPERATION SURROUNDINGS		SET	CANCEL
STARTING ADDRESS OF SYSTEM DATA AREA	[
SYSTEM AREA READING AREA SIZE (0-256)	[]	
RESET GP ON DATA WRITE ERROR	ON	OFF	
<p>Note! The system start address cannot be changed on GP. Please use GP-PRO/PB3 to set this data and re-send to the GP.</p>			
	1	2	3
	4	5	6
	7	8	9
	0	↑	↓
			BS
		←	→

<<GP-377R/GP-2300/GLC2300 Series>

SETUP OPERATION SURROUNDINGS	SET	ESC
SYSTEM AREA START ADR		
SYSTEM AREA READ SIZE		
RESET GP ON WRITE ERROR		
<p>Please use GP-PRO/PB3 to modify the system start address.</p>		



The System Area Start Address settings cannot be changed from the GP's OFFLINE mode. Be sure to make these settings from the GP Screen Editor's [GP SYSTEM SETUP] -> [MODE SETUP] setting area.



This manual, 7.8.3 Environment Setup ■GP-PRO/PBIII for Windows Settings

◆ **SETUP ETHERNET INFORMATION**

Enter each item in the SET UP ETHERNET INFORMATION screen.

<GP-477R/GP-577R/GP-2400/GP-2500/GP-2501/GP-2600/GLC2400/GLC2600 Series>

<GP-377R/GP-2300/GLC2300 Series>

- **SRC IP ADDRESS (0 to 255)**

Enter the IP address for your station’s GP unit. To do this, separate the 32 bits of the IP address into four segments of eight bits each, separate those segments with a dot and then enter them as decimal numbers.

- **SRC PORT NO. (1024 to 65535)**

Enter your GP’s Port No.



Do not specify duplicate IP addresses. Contact your network manager about assigning IP addresses.



- When using the built-in Ethernet port on a GP2000 Series unit, be sure not to enter duplicate "SRC PORT No." values.

Check the 2-Way driver's "SRC PORT No." Setting via the following menu:

GP OFFLINE mode's Main menu [INITIALIZE] -> [SETUP OPERATION SURROUNDINGS] -> [EXTENDED SETTINGS] -> [SETUP ETHERNET INFORMATION] screen.

The default value is 8000. The 2-Way driver uses this port and the following nine ports for a total of 10 (8000 ~ 8009).

When "SRC IP ADDRESS" is [0.0.0.0], the IP ADDRESS set in 2-Way Driver is enabled.

◆SET UP NETWORK EXT. INFORMATION

<GP-477R/GP-577R/GP-2400/GP-2500/GP-2501/GP-2600/GLC2400/GLC2600 Series>

SETUP ETHERNET EXT. INFORMATION		SET	CANCEL																														
SEND WAIT TIME	[] (ms)																																
TIMEOUT	[] (x 2sec)																																
IP ROUTER ADDRESS	[] . [] . [] . []																																
SUBNET MASK	[] . [] . [] . []																																
UDP RETRY COUNT(0-255)	[]																																
<table border="1"> <tr> <td></td><td>1</td><td>2</td><td>3</td><td>4</td><td>5</td><td>6</td><td>7</td><td>8</td><td>9</td><td>0</td><td></td><td>↑</td><td>↓</td><td>BS</td> </tr> <tr> <td></td><td></td><td></td><td></td><td></td><td></td><td></td><td></td><td></td><td></td><td></td><td></td><td>←</td><td>→</td><td></td> </tr> </table>					1	2	3	4	5	6	7	8	9	0		↑	↓	BS													←	→	
	1	2	3	4	5	6	7	8	9	0		↑	↓	BS																			
												←	→																				

<GP-377R/GP-2300/GLC2300 Series>

SETUP NETWORK EXT. INFORMATION		SET	ESC
SEND WAIT TIME	[] (ms)		
TIMEOUT	[] (x 2sec)		
IP ROUTER ADD.	[] . [] . [] . []		
SUBNET MASK	[] . [] . [] . []		
UDP RETRY COUNT(0-255)	[]		

- **SEND WAIT TIME (0 to 255)**

Wait time can be added when a command is transmitted from the GP. Use the wait time if the traffic on the communications line is heavy. If no wait time is required, enter “0.”

- **TIMEOUT (0 to 65535)**

Enter the desired timeout value. If no response is received from the other station within the specified time, a timeout occurs. If “0” is specified, the default time is 5 seconds with UDP/IP communication.

- **IP ROUTER ADDRESS**

Enter the IP address of the router (only one). If no router is used, enter “0” in all fields.

- **SUBNET MASK**

Enter the subnet mask settings. If no subnet mask is used, enter “0” in all fields.

- **UDP RETRY COUNT (0 to 255)**

This setting cannot be used and the setting value is disabled.



- ***If GP memory is initialized in OFFLINE mode, random values may be included. Download the GP System Setting data from GP-PRO/PBIII for Windows.***

◆ When using SLC500 Series unit

• DESTINATION NODE INFORMATION

<GP-477R/GP-577R/GP-2400/GP-2500/GP-2501/GP-2600/GLC2400/GLC2600 Series>

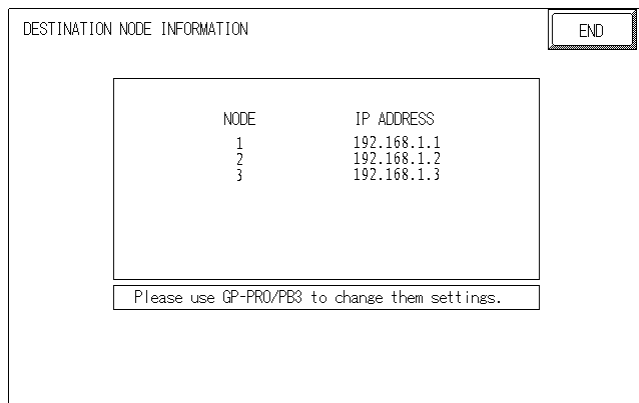

<GP-377R/GP-2300/GLC2300 Series>

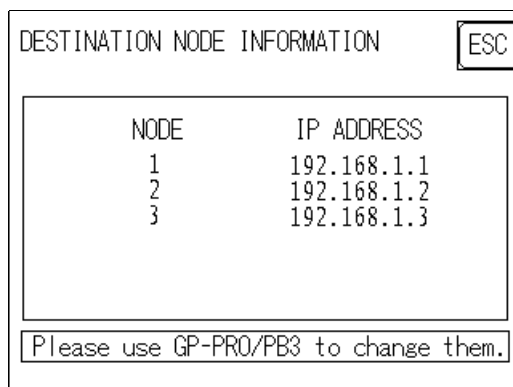

• DESTINATION NODE INFORMATION

The Destination (PLC) Network Address, Destination Node Address and IP Address are displayed here.



The DESTINATION NODE INFORMATION cannot be set or changed from OFFLINE mode. Set or change these values from GP-PRO/PBIII for Windows [GP SYSTEM SETTINGS]-> [MODE SETTINGS]-> [NETWORK INFORMATION SETTINGS].

Reference This manual, 7.8.3 Environment Setup ■GP-PRO/PBIII for Windows Settings

◆ When using Control Logix 5000 Series unit

• DESTINATION NODE INFORMATION

<GP-2400/GP-2500/GP-2600/GLC2400/GLC2600 Series>

DESTINATION NODE INFORMATION		
END		
NODE	IP ADDRESS	SLOT No.
1	192.168.1.1	0
2	192.168.1.2	1
Please use GP-PRO/PB3 to change them settings.		

<GP-2300/GLC2300 Series>

DESTINATION NODE INFO		
ESC		
NODE	IP ADDRESS	SLOT NO.
1	192.168.1.1	0
2	192.168.1.2	1
Please use GP-PRO/PB3 to change them.		

• DESTINATION NODE INFORMATION

Each PLC Node Number's IP Address and Slot No. are displayed here.



The DESTINATION NODE INFORMATION cannot be set or changed from OFFLINE mode. Set or change these values from GP-PRO/PBIII for Windows [GP SYSTEM SETTINGS]-> [MODE SETTINGS]-> [NETWORK INFORMATION SETTINGS].

This manual, 7.8.3 Environment Setup ■GP-PRO/PBIII for Windows Settings



■ GP-PRO/PBIII for Windows settings

The following items can be entered from GP-PRO/PBIII for Windows [GP SYSTEM SETTINGS] -> [MODE SETTING] area.

Menu	Sub Menu	Item
Communication Settings	_____	Source IP Address Source IP Port No.
	Advanced Communication Settings	Send Wait Time
		Time Out
		IP Router Address
		Subnet Mask
	UDP Retry Count	
Mode Settings	_____	System Start Address Read Area Size
	Network...	SLC500 Destination Node No. Destination Ip Address
		Control Logix 5000 Destination Node Information Destination Ip Address Slot Number

◆ COMMUNICATION SETTINGS

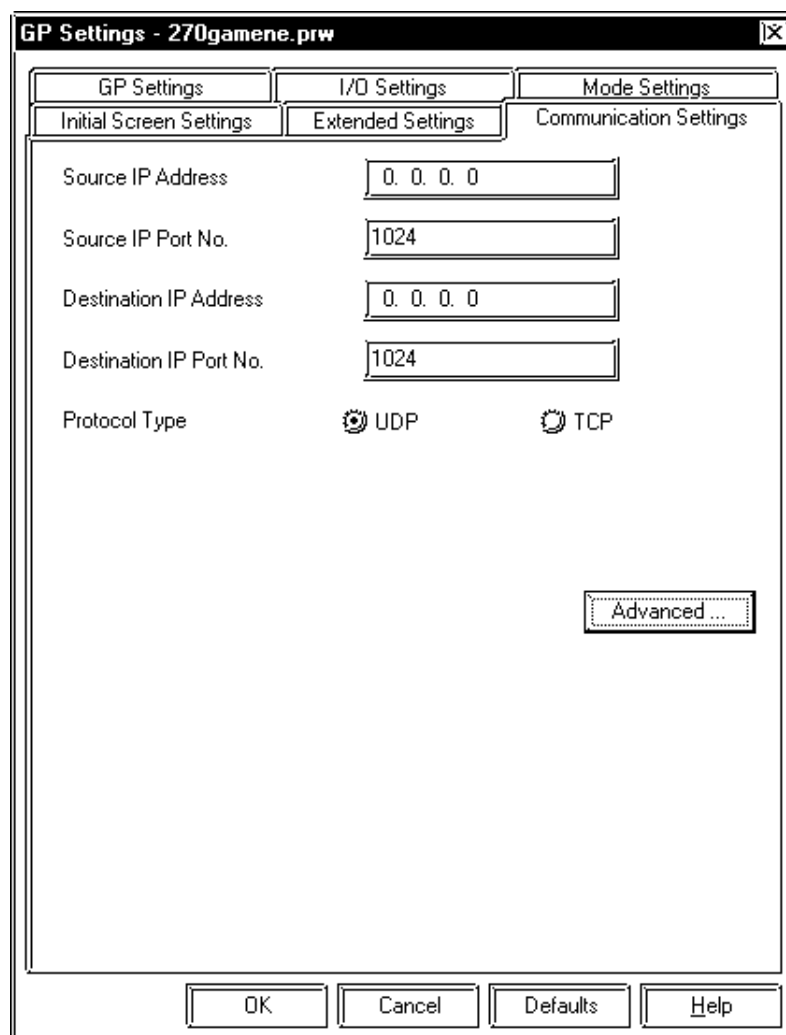

- **Source IP Address (0 to 255)**

Enter the IP address for your station's GP unit. To do this, separate the 32 bits of the IP address into four segments of eight bits each, separate those segments with a dot and then enter them as decimal numbers.

- **Source IP Port No. (1024 to 65535)**

Enter the GP's Port No.

- **Destination IP Address (0 to 255)**

This setting cannot be used.

- **Destination IP Port No. (1024 to 65535)**

This setting cannot be used.

- **Protocol Type**

This setting cannot be used.

- **ADVANCED COMMUNICATION SETTINGS**

Parameter	Value	Unit
Send Wait Time	0	msec
Time Out	0	x2 sec
IP Router Address	0.0.0.0	
Subnet Mask	0.0.0.0	
UDP Retry Count	2	

- **Send Wait Time (0 to 255)**

Wait time can be added when a command is transmitted from the GP. Use the wait time if the traffic on the communication line is heavy. If no wait time is required, enter "0."

- **Time Out (0 to 65535)**

Enter the desired timeout value. If no response is received from the other station within the specified time, a timeout occurs. If "0" is specified, the default time is 5 seconds with UDP/IP communication.

- **IP Router Address**

Enter the IP address of the router (only one). If no router is used, enter "0" in all fields.

- **Subnet Mask**

Enter the subnet mask settings. If no subnet mask is used, enter "0" in all fields.

- **UDP Retry Count (0 to 255)**

This setting cannot be used.

◆MODE SETTINGS

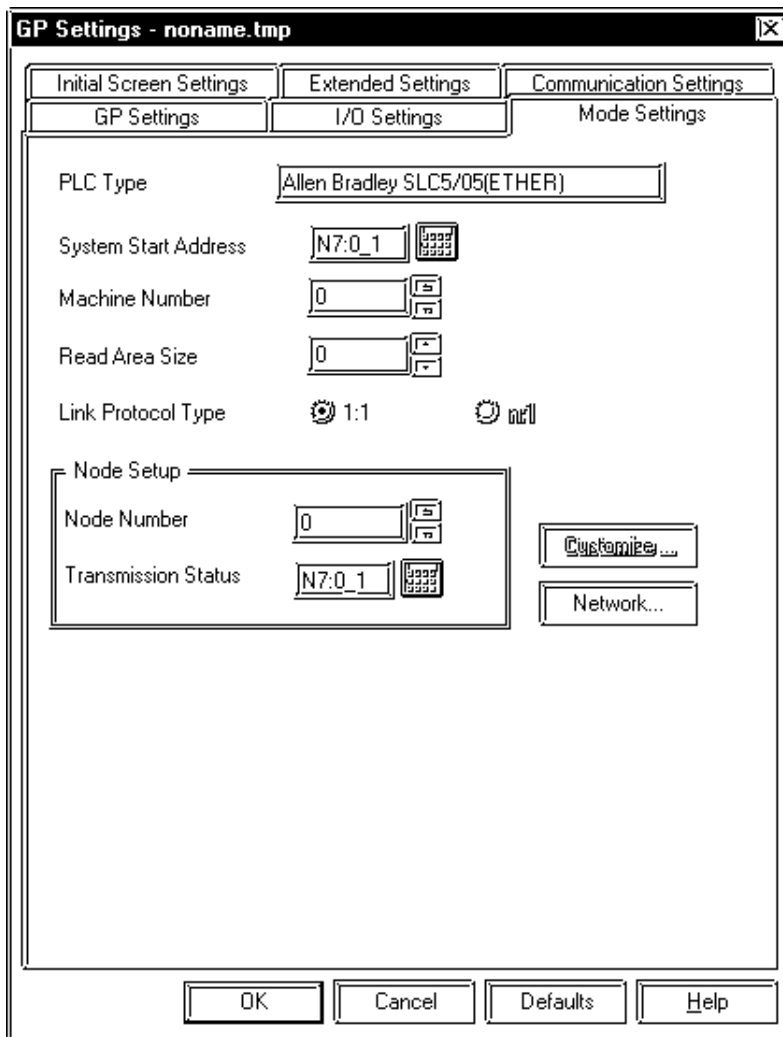

• **System Start Address**

The System Start Address is assigned to the PLC node designated here. For setting procedures, refer to 7.8.2 Supported Devices.

- **NETWORK INFORMATION SETTINGS**

Click the [Network...] button from [GP System Setting]-[Mode Setting] tab, and the Network Information window will appear.

Enter or edit the Destination Node Information.

When using an SLC500 Series unit

Destination Node Information	
	IP address
Node No. 1	0. 0. 0. 0
Node No. 2	0. 0. 0. 0
Node No. 3	0. 0. 0. 0

OK Cancel Help

- **Destination Node Information**

Register IP Address to each destination PLC Node number. The Maximum number of Nodes is 3. The Destination Node IP Address needs to be set to the same address as the target PLC or the junction (intermediate) PLC's IP address.

When using an Control Logix 5000 Series unit

The screenshot shows a dialog box titled "ControlLogix EtherNet/IP". Inside the dialog, there is a section labeled "Target" which contains four input fields:

- No. of node: A dropdown menu with the value "1" selected.
- Node No.: A dropdown menu with the value "1" selected.
- IP address: A text box containing "0.0.0.0".
- Slot No.: A text box containing "0".

At the bottom of the dialog, there are three buttons: "Ok", "Cancel", and "Help".

- **Target No. of node**

Designate the number of PLCs connected to one GP unit as either 1 or 2. If the number is 2, specify each Node Number and its corresponding IP Address. This Node Number is used when designating tag addresses.

- **Target Node No.**

Indicates the Node Number of the PLC designated by the IP Address.

- **Target IP address (0 to 255)**

Enter your PLC's IP address.

- **Target Slot No.**

Enter the PLC Slot No. used for installing the CPU unit.

■ PLC Setting

◆ SLC500 Series

GP Settings		PLC Settings	
Source IP Address	GP IP Address ^{*1}	-	-
Source Node Address	GP Port No. ^{*2}	-	-
Network Information Setting	Target PLC IP Address ^{*1}	IP Address	PLC IP Address

**1 Contact your network administrator about setting values.*

**2 When using the following function on a GP2000 Series unit, be sure not to use duplicate port number values. Check the 2-Way driver's port number setting via the following menu:*

From the GP OFFLINE mode's Main menu [INITIALIZE] -> [SETUP OPERATION SURROUNDINGS] -> [EXTENDED SETTINGS] -> [SETUP ETHERNET INFORMATION].

The default value is 8000. The 2-Way driver uses this port and the following nine ports for a total of 10 (8000 ~ 8009).



- **Protocol Type is TCP/IP Connection.**

◆ Control Logix 5000 Series

GP Settings		PLC Settings	
IP Address	GP IP Address ^{*1}	—	—
Port No.	GP Port No. ^{*2}	—	—
Target IP Address	PLC IP Address ^{*1}	IP Address	PLC IP Address
Slot No.	PLC Slot No.	—	—

**1 Contact your network administrator about setting values.*

**2 When using the following function on a GP2000 Series unit, be sure not to use duplicate port number values. Check the 2-Way driver's port number setting via the following menu:*

From the GP OFFLINE mode's Main menu [INITIALIZE] -> [SETUP OPERATION SURROUNDINGS] -> [EXTENDED SETTINGS] -> [SETUP ETHERNET INFORMATION].

The default value is 8000. The 2-Way driver uses this port and the following nine ports for a total of 10 (8000 ~ 8009).



- **Protocol Type is TCP/IP Connection.**

7.8.4 Error Code

Reference *About the GP Ethernet Specific Error Codes, refer to the end of this Chapter, “Protocol Stack Error Codes”.*

■ PLC SPECIFIC ERROR CODES

◆ SLC500 Series

The PLC error codes are displayed by the “Host Communication Error (02:**:##)”, and are indicated in the left lower corner of the GP screen. (** indicates the PLC error codes. ## indicates the PLC node number.)

Error Code	Contents
10	The devices are not designated or the designated addresses are out of range.

Reference *For information about error codes, refer to Rockwell (Allen-Bradley)’s User Manual for SLC500 Series.*

◆ Control Logix 5000 Series

The PLC error codes are displayed by the “Host Communication Error (02:**:##)”, and are indicated in the left lower corner of the GP screen. (** indicates the PLC error codes. ## indicates the PLC node number.) During data communication, the GP unit inserts 0xD0 to prevent the Local STS error code from overlapping with the Remote STS error code. When looking up PLC error codes in the manual, please note that error numbers larger than 0xD0 should be read after subtracting 0xD0.

GP Error Code	PLC Error Code
10	→ 10 (Remote STS Error code)
E1	→ 11 (EXT STS Error code)

Error Code	Contents
10	The devices are not designated or the designated addresses are out of range.

Reference *For information about error codes, refer to Rockwell (Allen-Bradley)’s User Manual for SLC500 Series.*



A1

Maximum Number of Consecutive PLC Addresses

The following lists the maximum number of consecutive addresses that can be read by each PLC. Refer to these tables to utilize *Block Transfer*.

■ Control Logix 5000 Series

Device	Max. No. of Consecutive Address
Bit (BOOL)	61 double words
8 bit integer (SINT)	42 words
16 bit integer (INT)	
32 bit integer (DINT)	61 double words
32 bit float (REAL)	

A2

Device Codes and Address Codes

E-tag or K-tag indirect addresses cannot be designated by a Control Logix 5000 Series unit on an Ethernet network.

A3

Address Conversion Tables

The following lists the address global replacement.

- : When the selected conversion mode is [Word], both word and bit addresses are converted. When the [Bit] is selected, only bit addresses are converted.
- △: When the selected conversion mode is [Word], only word addresses are converted. When the [Bit] is selected, only bit addresses are converted.
- ☆: When the [Word] mode is selected, only word addresses are converted.
- : When the [Bit] mode is selected, only bit addresses are converted.
- Blank: Cannot be converted.

■ Control Logix 5000 Series

		After Conversion					
		BOOL	SINT	INT	DINT	REAL	LS
Before Conversion	Bit (BOOL)	○	○	○	○		○
	8 bit integer (SINT)	○	○	○	○	☆	○
	16 bit integer (INT)	○	○	○	○	☆	○
	32 bit integer (DINT)	○	○	○	○	☆	○
	32bit float (REAL)		☆	☆	☆	☆	☆
	LS Area (LS)	○	○	○	○	☆	○