

**GP-PRO/PBIII for Windows
Device/PLC CONNECTION MANUAL**

ADDITIONAL MANUAL

Hitachi Industrial Equipment System Co. Ltd

**HIDIC H Series
(Ethernet)**

Reading the GP-PRO/PBIII Device/PLC Connection Manual

This document is designed as an addition to the latest GP-PRO/PBIII for Windows Device/PLC Connection manual's Hitachi Industrial Equipment System's HIDICH Series (Ethernet) data.

For information concerning general type PLC connections and this document's documentation conventions, please refer to your Device/PLC Connection manual.

When connecting a Factory Gateway unit, please substitute the words "Factory Gateway" for this document's "GP/GLC".

The information in this document will be included in the next version of the Device/PLC Connection manual.

Installation

This CD-ROM includes all the protocol files required by the GP/GLC to communicate with a Hitachi Industrial Equipment System's PLC. Also, you will need to have one or more of the following software applications installed, the screen and data transfer file included in the CD-ROM must be installed in each of those applications. For information about the installation of the software, refer to that software's Operation Manual.

■ Software Applications

- GP-PRO/PBIII for Windows Ver.6.1 or later
- Pro-Server with Pro-Studio for Windows Ver.4.1 or later ^{*1}

- 1) Be sure to confirm that GP-PRO/PBIII for Windows is installed in your PC prior to starting this driver installation.
- 2) To install the new Hitachi Industrial Equipment System driver, double-click on "HIDIC_HE.exe" for HIDIC H Ethernet connection.
- 3) Once the setup program starts, follow the instructions given to install the protocol files.



When using the HIDIC H Series unit Ethernet protocol, select [Others] - [HITACHI HIDIC H (ETHER)] for the " Device/PLC Type" .





***1 When using the Factory Gateway unit, GP-Web Ver.1.0 or later or GP-Viewer Ver.1.0 or later, be sure to select the Pro-Server with Pro-Studio for Windows as the "Destination Folder".**

7.7 Hitachi Industrial Equipment System

7.7.1 System Structure for Ethernet Connection

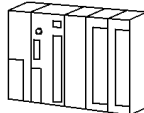
This section explains the system structures for the Ethernet connection between Hitachi Industrial Equipment System PLCs and GP units.

■HIDIC H Series

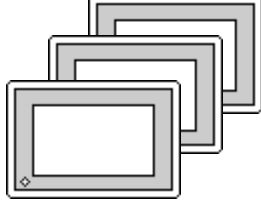
CPU	Link/I/F	Cables	Unit	GP
	 Ethernet Unit			
H4010(CPU3-40H) H2002(CPU2-20H) H1002(CPU2-07H) H702(CPU2-20H) H302(CPU2-40H)	LAN-ETH	Ethernet cable (compatible with the IEEE802.3)	Pro-face Ethernet I/F Unit GP070-ET41 GP377-MLTE11 GP377-MLTE41 GP077-MLTE41	GP/GLC Series ^{*1}

**1 Refer to the following table for compatible GP/GLC units and Ethernet connection information.*

Series Name	Product Name	Optional Ethernet I/F Unit	Built-in Ethernet Port	
GP77R Series	GP-377R Series	GP-377RT	○ ^{*1*2}	x
	GP-477R Series	GP-477RE	○ ^{*2}	x
	GP-577R Series	GP-577RS	○ ^{*2}	x
		GP-577RT	○ ^{*2}	x
GP2000 Series	GP-2300 Series	GP-2300L	x	○
		GP-2300T	x	○
	GP-2400 Series	GP-2400T	x	○
	GP-2500 Series	GP-2500L	○ ^{*3*4}	○
		GP-2500S	○ ^{*3*4}	○
		GP-2500T	○ ^{*3*4}	○
	GP-2501 Series	GP-2501S	○ ^{*2*3}	x
		GP-2501T	○ ^{*2*3}	x
GP-2600 Series	GP-2600T	○ ^{*3*4}	○	
GLC2000 Series	GLC-2300 Series	GLC-2300L	x	○
		GLC-2300T	x	○
	GLC-2400 Series	GLC-2400T	x	○
	GLC-2600 Series	GLC-2600T	○ ^{*3*4}	○

**1 Only the Multi Unit can be used.*

**2 The 2-Way Driver (Pro-Server, GP-Web and others) cannot be used.*

*3 When using optional Ethernet I/F unit, a bus conversion unit (PSL-CONV00) is required.

*4 Using the optional Ethernet I/F Unit allows you to set up separate Class and Net No.s for 2-Way Driver applications (Pro-Server, GP-Web and others) and the PLC. When doing this, data transfer with the PLC is performed through the optional Ethernet I/F Unit.



- For cable connections, refer to the user's manual for each optional unit. For the GP2000 and GLC2000 series units, however, refer to the User Manual for the main unit.

◆ Connection Structure

<1 : n connection>

UDPCOnnection: Up to 32 units
 TCPConncetion: Up to 3 units(GP2000/GLC2000 series)
 Up to 2 units (GP77R series)

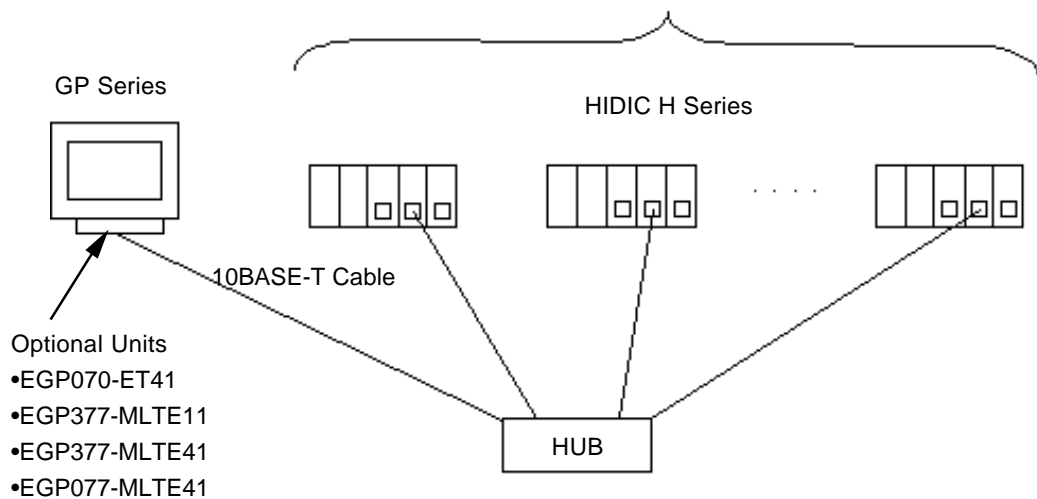

- Optional Units
- EGP070-ET41
 - EGP377-MLTE11
 - EGP377-MLTE41
 - EGP077-MLTE41

◆ Connection Structure

<1 : n connection>

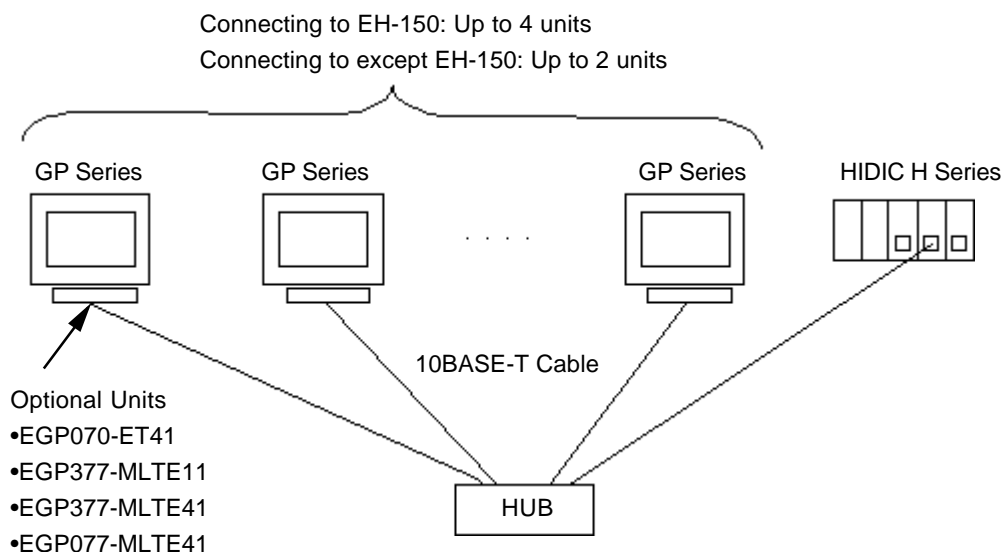

<Multiple CPU Links>

PLCs on Ethernet Network:

UDP Connection: Up to 32 units

TCP Connection: Up to 3 units (GP2000/GLC2000 series)

Up to 2 units (GP77R series)

PLC using CPU Link: Up to 64 units

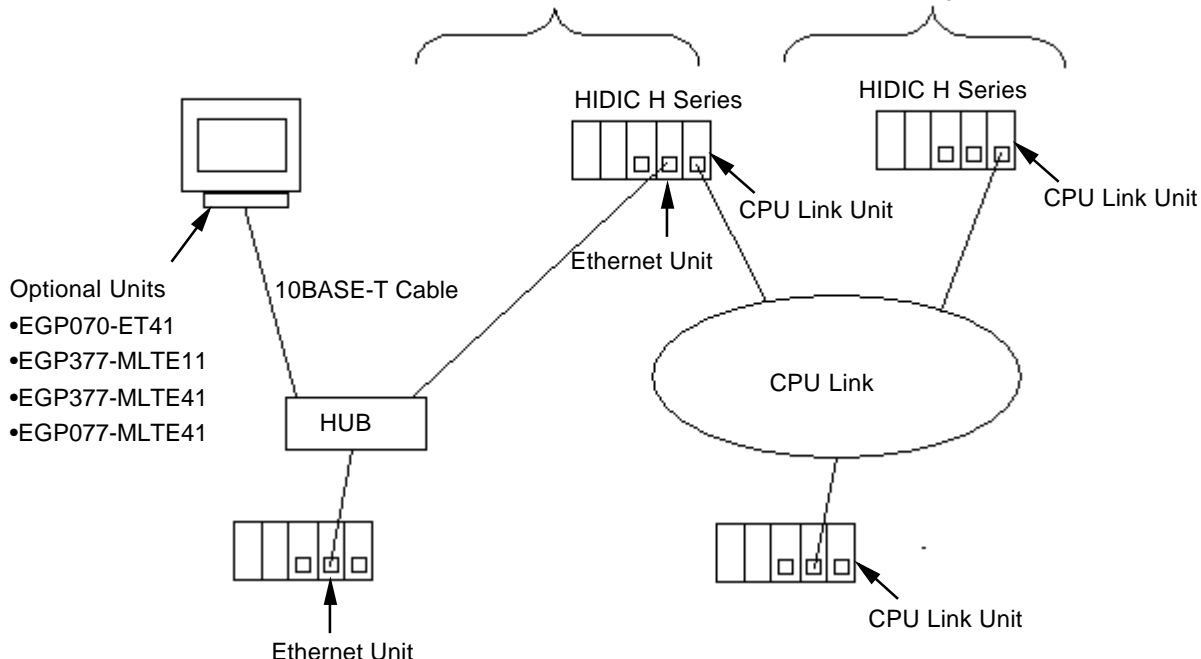

7.5.2 Supported Devices

The following list shows the range of devices supported by the GP.

■HIDIC H Series

 Setup System Area here.

Device	Bit Address	Word Address	Double Word Address	Other
External Input	X0000 ~ X05A95	WX0000 ~ WX05A7	DX0000 ~ DX05A6	*1
External Output	Y00000 ~ Y05A95	WY0000 ~ WY05A7	DY0000 ~ DY05A6	*1
Remote Input Relay	X10000 ~ X49A95	WX1000 ~ WX49A7	DX1000 ~ DX49A6	*1
Remote Output Relay	Y10000 ~ Y49A95	WY1000 ~ WY49A7	DY1000 ~ DY49A6	*1
Internal Output	R000 ~ R7BF	———	———	
Level 1 CPU Link	L00000 ~ L03FFF	WL0000 ~ WL03FF	DL0000 DL03FE	
Level 2 CPU Link	L10000 ~ L13FFF	WL10000 ~ WL13FF	DL1000 ~ DL13FE	
Data Area	M0000 ~ M3FFF	WM0000 ~ WM3FF	DM0000 ~ DM3FE	
On Delay Timer	TD0000 ~ TD1023	———	———	
Signal Shot Timer	SS0000 ~ SS1023	———	———	
Watchdog Timer	WDT0000 ~ WDT1023	———	———	
Monostable Timer	MS0000 ~ MS1023	———	———	
Accumulation Timer	TMR0000 ~ TMR1023	———	———	
Up Counter	CU0000 ~ CU2047	———	———	
Link Counter	RCU0000 ~ RCU2047	———	———	
Up/Down Counter	CT0000 ~ CT2047	———	———	
Timer/Counter (elapsed value)	———	TC0000 ~ TC2047	———	
Word Internal Output	———	WR0000 ~ WRC3FF	DR0000 ~ DRC3FE	Bit F
Network Link Area	———	WN0000 ~ WN7FFF	DN0000 ~ DN7FFE	Bit F

L/H

*1 Write your data as follows.

E.g. External Input unit No. 1, Slot No. 2, Module Bit No. 34

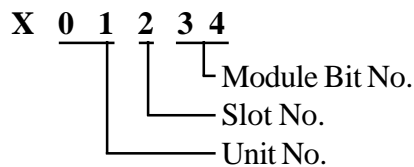

E.g. External Input unit No. 1, Slot No. 2, Module Word No. 3.

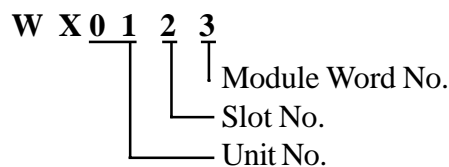

■HIDIC H Series Ethernet Protocol Limitation

Even though the HIDIC H Ethernet Protocol can access more than one CPU, the following limitations apply.

◆Device Address and Node Number Limitations

When a device address’s size is larger than 1024 (1K) or a different Node Number set, the number of available device addresses will vary. The GP uses internal records that are used to set the device addresses. These records are limited to 64. For example, when the WR0 device address is set, a single record is used in the GP. For detailed examples, refer to the following chart.

Ex1.) Number of records used when designating tag setting numbers.

Setting No.	Node Number	Device Address	Remaining Number of records in GP-PRO/PBIII	Note
1	1	WR0	63	Uses one record
2	1	WR1024	62	Uses one record
3	2	WR0	61	Uses one record
4	2	WR1024	60	Uses one record
5	1	WM0	60	Since the Node Number and address range already exist as setting No.1, no records will be used.
6	1	WM1024	60	Since the Node Number and address range already exist as setting No.2, no records will be used.
7	1	WR2048	59	Uses one record
8	2	WR2048	58	Uses one record
9	3	WR2048	57	Uses one record
10	3	WR2049	57	Since the Node Number and address range already exist as setting No.9, no records will be used.

When the total number of Node Number and Device Addresses exceeds 1024, GP internal records are used. However, if the Node Number and Device Address are the same type, no record will be used, even if the device types are different.

Ex2.) When setting tags from WR0000 to WR4000 in Word Internal Output, since one record is used for every 1024 addresses, a total of 16 records will be used.

$$16384(0x4000)/1024=16$$

Therefore, when setting the same number of tags for each node, settings for a total of four nodes can be set.

$$64/16=4$$



Note: When the number of records is over 65, the following error message will appear on GP-PRO/PBIII for Windows.

“Address entry limit reached. No more can be entered.”

◆ **PLC Device Block Write Restrictions**

The GP unit processes data internally by separating data into blocks of 1024 words.

Therefore, when a Block Write is requested that uses 41 or more words and will exceed the 1024 word limit, the following features cannot be used.

- PLC Device Write using D-Script's Memory Operation Feature
- Write from GP/GLC SRAM to PLC Device using Filing Feature
- Write to LS Area's Read Area

When using these settings, a Host Communication Error may occur.

If an error occurs, separate the data so that the number of words used by the Block Write is 1024 or less.

◆ **When setting up Parts or Tags from GP-PRO/PBIII for Windows**

Before setting up Parts or Tags, Network Information settings must be entered. Network Information Setting can be set from the [GP SYSTEM SETTING]->[MODE SETTING]->[Network Information] screen.

Reference This manual, 7.7.3 Environment Setup

Specifying the PLC's Node Address when setting parts or tags allows the specified PLC's Device to be read out.

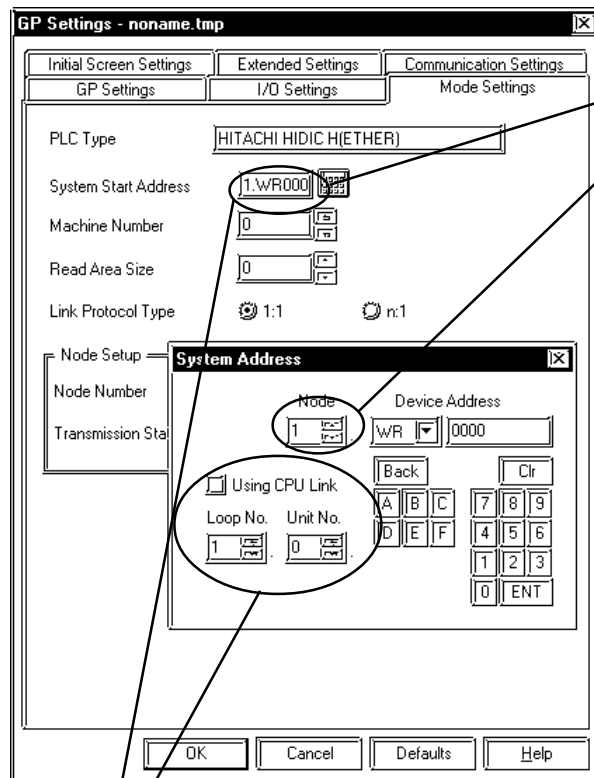

The System Area and Read Area are assigned to the PLC node designated here.

Depending on if the CPU Link is used or not address settings will differ.

<When CPU Link is NOT used>

Set the [Using CPU Link] check box to OFF.

1. WM0000
 └── Device Address
 └── Node No.(UDP Connection: 1 to 32, TCP Connection: 1 to 3)

<When CPU Link is used>

Set the [Using CPU Link] check box to ON (checked mark). When using the CPU Link, Loop No. and Unit No. are included in the address.

Ex.) Using Node Address is 1, Loop No. is 2 and Unit No. is 3

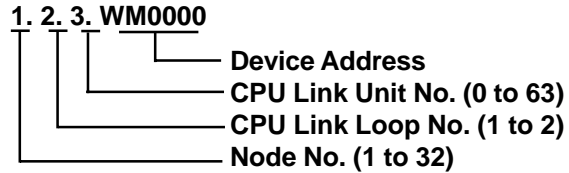

When setting up Parts or Tags using GP-PRO/PBIII for Windows, the PLC's Node Address can be designated when entering the address. When the Node Address is not specified, the previously entered numbers will remain.

7.5.3 Environment Setup

■ GP Settings

The following screens show the GP/GLC's communication settings, which are required for communication via an Ethernet Network:

◆ SET UP OPERATION SURROUNDINGS MENU

<GP-477R/GP-577R/GP-2400/GP-2500/GP-2501/GP-2600/GLC2400/GLC2600 Series>

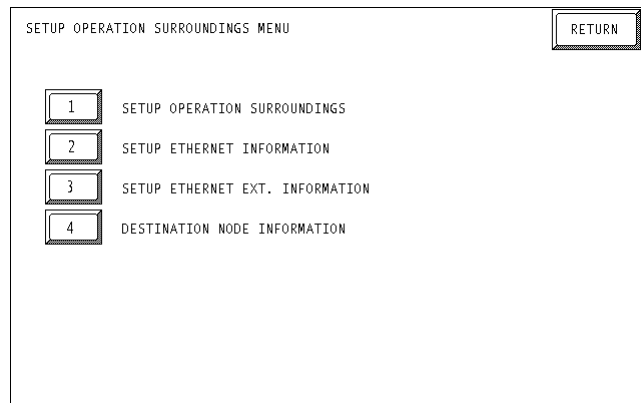

<GP-377R/GP-2300/GLC2300 Series>

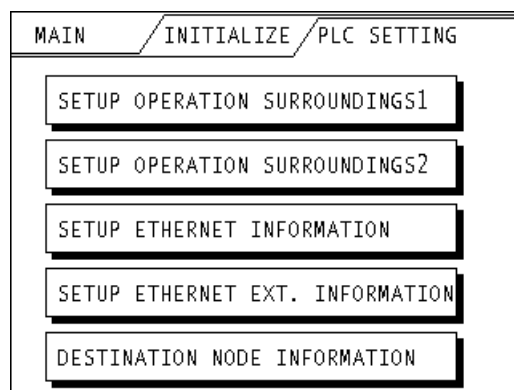

• SET UP OPERATION SURROUNDINGS

<GP-477R/GP-577R/GP-2400/GP-2500/GP-2501/GP-2600/GLC2400/GLC2600 Series>

SETUP OPERATION SURROUNDINGS										SET	CANCEL	
STARTING ADDRESS OF SYSTEM DATA AREA	[WR]											
DESTINATION NODE NO.	[]											
LOOP NO. , UNIT NO.	[,]											
SYSTEM AREA READING AREA SIZE (0-256)	[]											
RESET GP ON DATA WRITE ERROR	ON OFF											
<p>Note! The system start address, node address, loop no., and unit no. cannot be changed on GP. Please use GP-PRO/PB3 to set this data and re-send to the GP.</p>												
1	2	3	4	5	6	7	8	9	0	↑	↓	BS
										←	→	

<GP-377R/GP-2300/GLC2300 Series>

SETUP OPERATION SURROUNDINGS1		SET	ESC
SYSTEM AREA START ADR WR	<input type="text"/>		
DEST NODE NO.	<input type="text"/>		
LOOP NO.	<input type="text"/>		
UNIT NO.	<input type="text"/>		
Please use GP-PRO/PB3 to modify the above datas.			

SETUP OPERATION SURROUNDINGS2		SET	ESC
SYSTEM AREA READ SIZE	<input type="text"/>		
RESET GP ON WRITE ERROR	<input type="text"/>		



Be sure the Destination Node No. entered are the same as the PLC's settings. However, the Destination Node No. settings cannot be changed from the GP's OFFLINE mode. Be sure to make these settings from the GP-PRO/PBIII for Windows [GP SYSTEM SETUP] -> [MODE SETUP] setting area..



This manual, 7.7.3 Environment Setup ■GP-PRO/PBIII for Windows Settings

◆ **SETUP ETHERNET INFORMATION**

Enter each item in the SET UP ETHERNET INFORMATION screen.

<GP-477R/GP-577R/GP-2400/GP-2500/GP-2501/GP-2600/GLC2400/GLC2600 Series>

SETUP ETHERNET INFORMATION												SET	CANCEL	
SRC IP ADDRESS		[]	.	[]	.	[]	.	[]	.	[]				
SRC NETWORK ADDRESS		[]												
SRC NODE ADDRESS		[]												
FINS UDP PORT NO.		[]												
	1	2	3	4	5	6	7	8	9	0		↑	↓	BS
												←	→	

<GP-377R/GP-2300/GLC2300 Series>

SETUP ETHERNET INFORMATION												SET	ESC
SRC IP ADD.		[]	.	[]	.	[]	.	[]	.	[]			
SRC PORT NO.													
DEST PORT NO.													
PROTOCOL TYPE													

• **SRC IP ADDRESS (0 to 255)**

Enter the IP address for the GP at your station. To do this, separate the 32 bits of the IP address into four segments of eight bits each, separate those segments with a dot and then enter them as decimal numbers.

• **SRC PORT NO. (1024 to 65535)**

Enter your GP's Port No. from 1024 to 65535.

• **DEST PORT NO. (1024 to 65535)**

Enter the PLC's IP Port No. from 1024 to 65535. Enter the same value as the PLC's Logic Port No.. When connecting a single GP unit to multiple PLC units, set all PLC units' Port No. to the same value.

• **PROTOCOL TYPE**

Select UDP/IP or TCP/IP Communication. When the power is turned ON/OFF asynchronously, Pro-face recommends UDP/IP Communication.



Do not specify duplicate IP addresses. Contact your network manager about assigning IP addresses.



- When using the built-in Ethernet port on a GP2000 Series unit, be sure not to enter duplicate "SRC PORT No." values.

Check the 2-Way driver's "SRC PORT No." Setting via the following menu:

GP OFFLINE mode's Main menu [INITIALIZE] -> [SETUP OPERATION SURROUNDINGS] -> [EXTENDED SETTINGS] -> [SETUP ETHERNET INFORMATION] screen.

The default value is 8000. The 2-Way driver uses this port and the following nine ports for a total of 10 (8000 ~ 8009).

When "SRC IP ADDRESS" is [0.0.0.0], the IP ADDRESS set in 2-Way Driver is enabled.

◆SET UP NETWORK EXT. INFORMATION

<GP-477R/GP-577R/GP-2400/GP-2500/GP-2501/GP-2600/GLC2400/GLC2600 Series>

SETUP ETHERNET EXT. INFORMATION		SET	CANCEL
SEND WAIT TIME	[] (ms)		
TIMEOUT	[] (x 2sec)		
IP ROUTER ADDRESS	[] . [] . [] . []		
SUBNET MASK	[] . [] . [] . []		
UDP RETRY COUNT(0-255)	[]		

1	2	3	4	5	6	7	8	9	0			↑	↓	BS
												←	→	

<GP-377R/GP-2300/GLC2300 Series>

SETUP NETWORK EXT. INFORMATION		SET	ESC
SEND WAIT TIME	<input type="text"/> (ms)		
TIMEOUT	<input type="text"/> (x 2sec)		
IP ROUTER ADD.	[] . [] . [] . []		
SUBNET MASK	[] . [] . [] . []		
UDP RETRY COUNT(0-255)	<input type="text"/>		

- **SEND WAIT TIME (0 to 255)**

Wait time can be added when a command is transmitted from the GP. Use the wait time if the traffic on the communications line is heavy. If no wait time is required, enter “0.”

- **TIMEOUT (0 to 65535)**

Enter the desired timeout value. If no response is received from the other station within the specified time, a timeout occurs. If “0” is specified, the default time is 5 seconds with UDP/IP communication.

- **IP ROUTER ADDRESS**

Enter the IP address of the router (only one). If no router is used, enter “0” in all fields.

- **SUBNET MASK**

Enter the subnet mask settings. If no subnet mask is used, enter “0” in all fields.

- **UDP RETRY COUNT (0 to 255)**

Designates the number of times the GP re-sends a command when there is no reply from the other port and a timeout occurs. When no reply is received after the retry setting number is reached, an error message will appear on the GP screen.



- ***If GP memory is initialized in OFFLINE mode, random values may be included. Download the GP System Setting data from GP-PRO/PBIII for Windows.***

• DESTINATION NODE INFORMATION

<GP-477R/GP-577R/GP-2400/GP-2500/GP-2501/GP-2600/GLC2400/GLC2600 Series>

DESTINATION NODE INFORMATION		PREVIOUS	NEXT	END
NODE	IP ADDRESS			
1	192.168.1.1			
2	192.168.1.2			
3	192.168.1.3			
4	192.168.1.4			
Please use GP-PRO/PB3 to change them settings.				

<GP-377R/GP-2300/GLC2300 Series>

DESTINATION NODE INFO.		PRE	NEXT	ESC
NODE	IP ADDRESS			
1	192.168.1.1			
2	192.168.1.2			
3	192.168.1.3			
4	192.168.1.4			
Please use GP-PRO/PB3 to change them.				

• DESTINATION NODE INFORMATION

PLC Destination Node Number and IP Address are displayed here. Press [NEXT] button to see the next page.



The DESTINATION NODE INFORMATION cannot be set or changed from OFFLINE mode. Set or change these values from GP-PRO/PBIII for Windows [GP SYSTEM SETTINGS]-> [MODE SETTINGS]-> [NETWORK INFORMATION SETTINGS].



This manual, 7.7.3 Environment Setup ■ GP-PRO/PBIII for Windows Settings

■ GP-PRO/PBIII for Windows settings

The following items can be entered from GP-PRO/PBIII for Windows [GP SYSTEM SETTINGS] -> [MODE SETTING] area.

Menu	Sub Menu	Item
Communication Settings	_____	Source IP Address
		Source IP Port No.
		Destination IP Address
		Destination IP Port No.
		Protocol Type
	Advanced Communication Settings	Send Wait Time
		Time Out
		IP Router Address
		Subnet Mask
		UDP Retry Count
Mode Settings	_____	System Start Address
		Read Area Size
	Network...	Destination Node Information

◆ COMMUNICATION SETTINGS

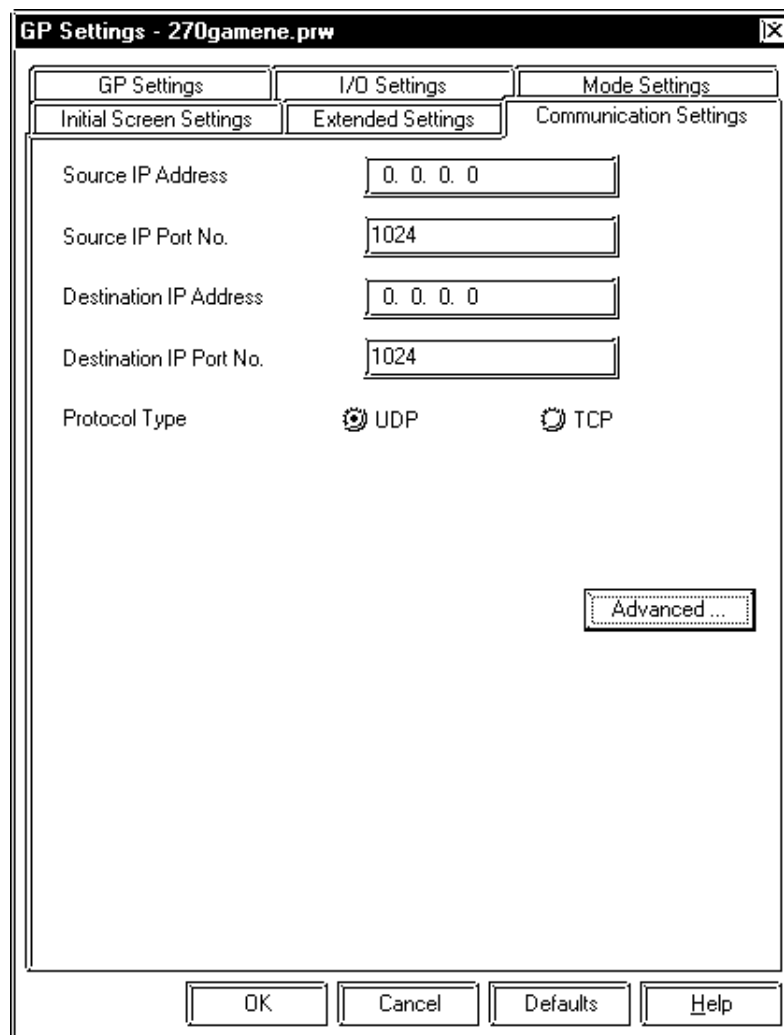

- **Source IP Address (0 to 255)**

Enter the IP address for the GP at your station. To do this, separate the 32 bits of the IP address into four segments of eight bits each, separate those segments with a dot and then enter them as decimal numbers.

- **Source IP Port No. (1024 to 65535)**

Enter the GP's Port No. from 1024 to 65535.

- **Destination IP Address (0 to 255)**

This setting cannot be used. Set the Destination IP Address from [Network Information Setting] in [Mode Setting] tab.

- **Destination IP Port No. (1024 to 65535)**

Enter the PLC's IP Port No. from 1024 to 65535. Enter the same value as the PLC's Logic Port No.. When connecting a single GP unit to multiple PLC units, set all PLC units' Port No. to the same value.

- **Protocol Type**

Select UDP/IP or TCP/IP Communication. When the power is turned ON/OFF asynchronously, we recommend UDP/IP Communication.

- **ADVANCED COMMUNICATION SETUP**

- **Send Wait Time (0 to 255)**

Wait time can be added when a command is transmitted from the GP. Use the wait time if the traffic on the communications line is heavy. If no wait time is required, enter "0."

- **Time Out (0 to 65535)**

Enter the desired timeout value. If no response is received from the other station within the specified time, a timeout occurs. If "0" is specified, the default time is 5 seconds with UDP/IP communication.

- **IP Router Address**

Enter the IP address of the router (only one). If no router is used, enter "0" in all fields.

• **Subnet Mask**

Enter the subnet mask settings. If no subnet mask is used, enter “0” in all fields.

• **UDP Retry Count (0 to 255)**

Designates the number of times the GP re-sends a command when there is no reply from the other port and a timeout occurs. When no reply is received after the retry setting number is reached, an error message will appear on the GP screen.

◆ **MODE SETTINGS**

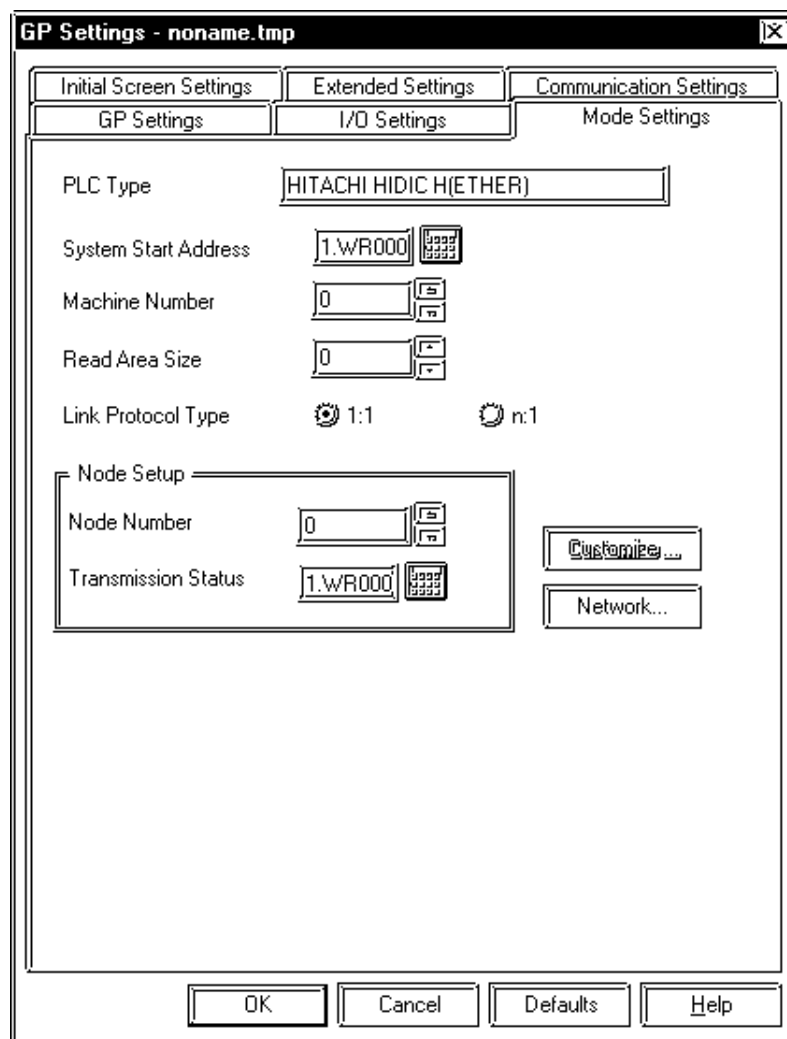

• **System Start Address**

The System Start Address is assigned to the PLC node designated here.

Reference For setting, refer to 8.7.2 Supported Devices

- **NETWORK INFORMATION SETTINGS**

Click the [Network...] button from [GP System Setting]-[Mode Setting] tab, and the Network Information window will appear.

Set and edit Destination Node Information here.

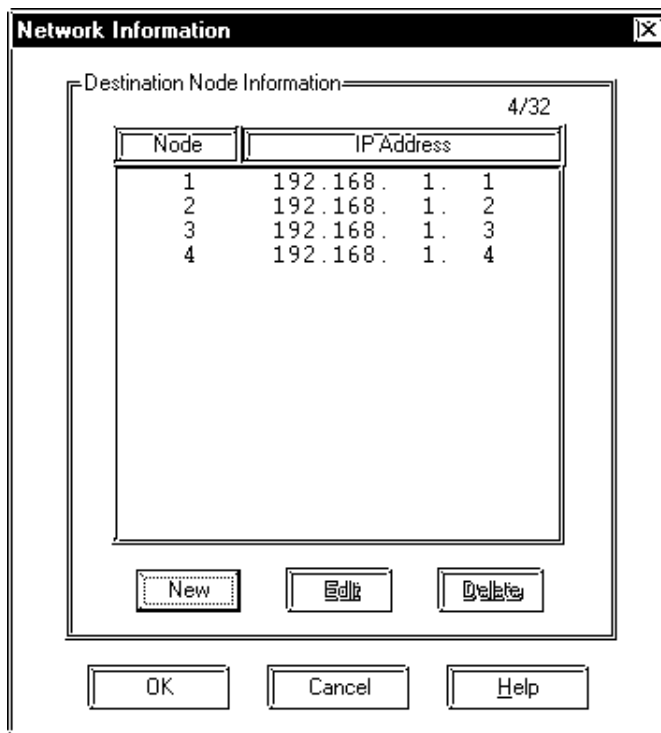

New Destination Node Information is entered using the following window.

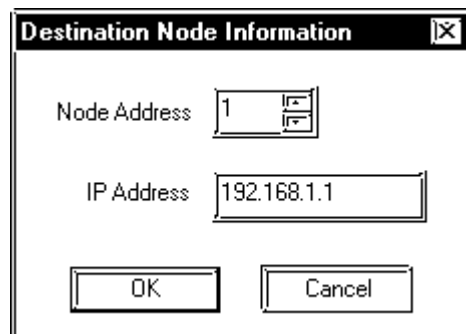

- **Destination Node Information**

Enter the destination PLC Node number. Click [New] or [Edit] button from Network Information window or double click the row you want to edit to display the Destination Node Information window.

The Maximum number of Nodes is 32. When the setting Node number is over 32 units, an error “Setting Node number is over 32 units. Cannot set any more.” appears. When entering the same Node number as the number you have already registered, the error message “The same Node number has already registered.” appears.

The Destination Node IP Address needs to be set to the same address as the target PLC or the junction (intermediate) PLC’s IP address.

■ PLC SETTINGS

◆ SYSMAC CS1 Series

GP Settings		PLC Settings	
Source IP Address	GP IP Address ^{*1}	-	-
Source Node Address	GP Port No. ^{*2}	-	-
Destination IP Address	Target PLC IP Address ^{*1}	IP Address	-
Destination IP Port No.	3004 to 3007	Logic Port No.	GP Node Address
Protocol type	UDP/TCP	Service Assortment	UDP/IP, TCP/IP
-	-	Task Code Port Time Out Value	20 sec. or longer

**1 Contact your network administrator about what setting values to use.*

**2 PLC's default Port number is 9600. Be sure to use the same number as the GP setting.*

When using the following function on a GP2000 Series unit, be sure not to use duplicate port number values. Check the 2-Way driver's port number setting via the following menu:

From the GP OFFLINE mode's Main menu [INITIALIZE] -> [SETUP OPERATION SURROUNDINGS] -> [EXTENDED SETTINGS] -> [SETUP ETHERNET INFORMATION].

The default value is 8000. The 2-Way driver uses this port and the following nine ports for a total of 10 (8000 ~ 8009).



Important

- **Be sure not to set a duplicate Node Address in the same Network Address group.**
- **When "SRC IP ADDRESS" is [0.0.0.0], the IP ADDRESS set in 2-Way Driver is enabled.**

7.5.4 Error Codes

Reference For information about GP Ethernet Specific Error Codes, refer to the end of this chapter, “Protocol Stack Error Codes”.

The PLC error codes are displayed by the “Host Communication Error (02:**)”, and are indicated in the left lower corner of the GP screen. (** indicates the PLC error codes)

■HIDIC H Series

The PLC error codes are sent as separated 2 byte codes. The GP/GLC units use a 1 byte code to display an error number.

Ex.) PLC Reply Command PLC Return Code GP Display Error

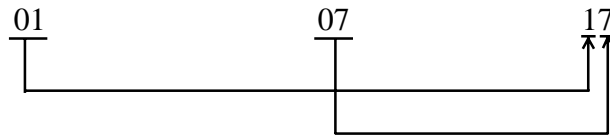

Error Code	Contents
16	Designated Device does no exist.
17	Designated device address is out of range.
80	Unable to access the designated link unit's PLC.

Reference For information about error codes, refer to Hitachi Industrial Equipment System User Manual for HIDIC H Series.

A1

Maximum Number of Consecutive PLC Addresses

The following lists the maximum number of consecutive addresses that can be read by each PLC. Refer to these tables to utilize *Block Transfer*.

■ HIDIC H Series

Device	Maximum Number of Consecutive Addresses
External Input	120 words
External Output	
Remote Input Relay	
Remote Output Relay	
Internal Output	
Level 1 CPU Link	
Level 2 CPU Link	
Data Area	
Timer/Counter (Elapsed value)	
Word Internal Output	
Network Link Area	

A2

Device Codes and Address Codes

E-tag or K-tag indirect address cannot be designated by a HIDIC H Series unit on an Ethernet network.

A3

Address Conversion Table

The following table lists the address conversions that are performed.

- : When the selected conversion mode is [Word], both word and bit addresses are converted. When the [Bit] is selected, only bit addresses are converted.
- △: When the selected conversion mode is [Word], only word addresses are converted. When the [Bit] is selected, only bit addresses are converted.
- ☆: When [Word] mode is selected, only word addresses are converted.
- : When [Bit] mode is selected, only bit addresses are converted.
- Blank: Cannot be converted.

■ HIDIC H Series

		After Conversion																
		X	Y	R	L	M	TD	SS	WDT	MS	TMR	CU	RCU	CT	TC	WR	WN	LS
Before Conversion	Input	○	○	○	○	○	☆	☆	☆	☆	☆	☆	☆	○	○	○	○	
	Output	○	○	○	○	○	☆	☆	☆	☆	☆	☆	☆	○	○	○	○	
	Internal Output	○	○	○	○	○	☆	☆	☆	☆	☆	☆	☆	○	○	○	○	
	CPU Link	○	○	○	○	○	☆	☆	☆	☆	☆	☆	☆	○	○	○	○	
	Data Area	○	○	○	○	○	☆	☆	☆	☆	☆	☆	☆	○	○	○	○	
	On Delay Timer	☆	☆	☆	☆	☆	☆	☆	☆	☆	☆	☆	☆	☆	☆	☆	☆	☆
	Signal Shot Timer	☆	☆	☆	☆	☆	☆	☆	☆	☆	☆	☆	☆	☆	☆	☆	☆	☆
	Watchdog Timer	☆	☆	☆	☆	☆	☆	☆	☆	☆	☆	☆	☆	☆	☆	☆	☆	☆
	Monostable Timer	☆	☆	☆	☆	☆	☆	☆	☆	☆	☆	☆	☆	☆	☆	☆	☆	☆
	Accumulation Timer	☆	☆	☆	☆	☆	☆	☆	☆	☆	☆	☆	☆	☆	☆	☆	☆	☆
	Up Counter	☆	☆	☆	☆	☆	☆	☆	☆	☆	☆	☆	☆	☆	☆	☆	☆	☆
	Link Counter	☆	☆	☆	☆	☆	☆	☆	☆	☆	☆	☆	☆	☆	☆	☆	☆	☆
	Up/Down Counter CT	☆	☆	☆	☆	☆	☆	☆	☆	☆	☆	☆	☆	☆	☆	☆	☆	☆
	Timer/Counter (elapsed value)	○	○	○	○	○	☆	☆	☆	☆	☆	☆	☆	☆	○	○	○	○
	Word Internal Output	○	○	○	○	○	☆	☆	☆	☆	☆	☆	☆	☆	○	○	○	○
	Network Link Area	○	○	○	○	○	☆	☆	☆	☆	☆	☆	☆	☆	○	○	○	○
LS Area	○	○	○	○	○	☆	☆	☆	☆	☆	☆	☆	☆	○	○	○	○	