

PLC CONNECTION MANUAL

ADDITIONAL MANUAL

Shimaden Co., Ltd.

SR253/SR90/SR80/MR13

FP93/SD16/EM70

Series Controllers

Reading the Device/PLC Connection Manual

This additional manual provides connection information for the Shimaden Co., Ltd. SR253/SR90/SR80/MR13/FP93/SD16/EM70 Series models, and is a supplement to the LT Editor and GP-PRO/PBIII for Windows Device/PLC Connection Manual.

Please refer to this data when connecting a Shimaden Co., Ltd. SR253/SR90/SR80/MR13/FP93/SD16/EM70 Series unit.

For information concerning general type PLC connections and this document's documentation conventions, please refer to your Device/PLC Connection manual.

When connecting a Factory Gateway unit, please substitute the words "Factory Gateway" for this document's "GP/GLC/LT".

The information in this document will be included in the next version of the Device/PLC Connection manual. Therefore, please consider this a provisional document.

Installation

This CD-ROM includes all the driver files required by the LT/GLC/GP to communicate with a SR253/SR90/SR80/MR13/FP93/SD16/EM70 Series Controllers. This document assumes that one or more of the following software applications are already installed on your PC. Please note that if more than one of these applications are installed, the screen and data transfer files included in this CD-ROM must be installed in each of those applications.

For information about the installation of the software, refer to that software's Operation Manual.

■ Software Applications

- LT Editor Ver.1.0 or later
- GP-PRO/PBIII for Windows Ver.5.0 or later
- Pro-server with Pro-Studio for Windows Ver.3.0 or later*¹

- 1) Confirm that the Screen Editor software is installed on your hard drive.
- 2) Double-click on the “shimaden.exe” file contained in the CD-ROM.
- 3) Once the set up program starts, follow the instructions given in the installation program.



When using the SR253/SR90/SR80/MR13/FP93/SD16/EM70 Series unit, select [shimaden controller] for the " PLC Type" .

When using GP-PRO/PBIII for Windows Ver.6.0 or later, click on the Device/PLC area's [other] selection and then click on [shimaden controller].

*** 1 When using the Factory Gateway unit, GP-Web Ver. 1.0 or later, or GP-Viewer Ver. 1.0 or later, Pro-Server with Pro-Studio for Windows must also be installed.**

12.10 Shimaden Co., Ltd. Controllers

12.10.1 System Structure

The following describes the system configuration used when connecting the GP/GLC to a Shimaden Controller.



• **GP/GLC's System Area (LS0 to LS19) Settings**

The GP/GLC's system area (20 words) cannot be allocated to the Controller's own data area. When you are entering the system area settings via the screen editor software or via the GP/GLC's OFFLINE screen, be careful that you do not use the Controller's own data area.

■ **SR253 Series**



Controller *1	Cable Diagram	GP/GLC
SR253-□□-□-□□□□□□7□	RS-232C (Cable Diagram 1)	GP Series GLC Series *2
SR253-□□-□-□□□□□□6□	RS-422 4-wire (Cable Diagram 3)	
	RS-422 4-wire 1:n Connection (Cable Diagram 4)	
SR253-□□-□-□□□□□□5□	RS-422 2-wire (Cable Diagram 5)	
	RS-422 2-wire 1:n Connection (Cable Diagram 6)	

*1 The model data "□" will vary depending on the type of option.

For detailed temperature Controller information, refer to that unit's catalog. Serial data transfer option types use a "7" for RS-232C, "6" for RS-422 - 4 wire, and "5" for RS-422 - 2 wire.

*2 Except for GP377 Series units, all GP70 Series and GLC100 Series units cannot be connected.

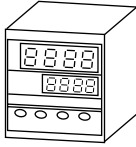
■ SR90 Series



Controller *1	Cable Diagram	GP/GLC
		
SR92-□□-□-□□-□□7□ SR93-□□-□-□□-□07□ SR94-□□-□-□□-□07□	RS-232C (Cable Diagram 2)	GP Series GLC Series *2
SR91-□□-□□-□5□ SR92-□□-□-□□-□□5□ SR93-□□-□-□□-□05□ SR94-□□-□-□□-□05□	RS-422 2-wire (Cable Diagram 7)	
	RS-422 2-wire 1:n Connection (Cable Diagram 8)	

*1 The model data "□" will vary depending on the type of option.

For detailed temperature Controller information, refer to that unit's catalog.
Serial data transfer option types use a "7" or "07" for RS-232C, and "5" or "05" for RS-422 - 2 wire.

*2 Except for GP377 Series units, all GP70 Series and GLC100 Series units cannot be connected.

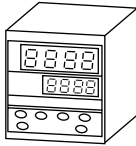
■ SR80 Series



Controller *1	Cable Diagram	GP/GLC
		
SR82-□□-□-□□-□□□□7□□ SR83-□□-□-□□-□□□□7□□ SR84-□□-□-□□-□□□□7□□	RS-232C (Cable Diagram 2)	GP Series GLC Series *2
SR82-□□-□-□□-□□□□5□□ SR83-□□-□-□□-□□□□5□□ SR84-□□-□-□□-□□□□5□□	RS-422 2-wire (Cable Diagram 7)	
	RS-422 2-wire 1:n Connection (Cable Diagram 8)	

*1 The model data "□" will vary depending on the type of option.

For detailed temperature Controller information, refer to that unit's catalog.
Serial data transfer option types use a "7" for RS-232C, and "5" for RS-422 - 2 wire.

*2 Except for GP377 Series units, all GP70 Series and GLC100 Series units cannot be connected.

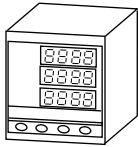
■ MR13 Series



Controller *1	Cable Diagram	GP/GLC
		
MR13-□□□-□□□□17□	RS-232C (Cable Diagram 2)	GP Series GLC Series *2
MR13-□□□-□□□□15□	RS-422 2-wire (Cable Diagram 7)	
	RS-422 2-wire 1:n Connection (Cable Diagram 8)	

*1 The model data "□" will vary depending on the type of option.

For detailed temperature Controller information, refer to that unit's catalog. Serial data transfer option types use a "17" for RS-232C, and "15" for RS-422 - 2 wire.

*2 Except for GP377 Series units, all GP70 Series and GLC100 Series units cannot be connected.

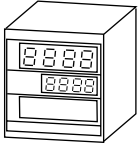
■ FP93 Series



Controller *1	Cable Diagram	GP/GLC
		
FP93-□□-□□-□□7□	RS-232C (Cable Diagram 2)	GP Series GLC Series *2
FP93-□□-□□-□□5□	RS-422 2-wire (Cable Diagram 7)	
	RS-422 2-wire 1:n Connection (Cable Diagram 8)	

*1 The model data "□" will vary depending on the type of option.

For detailed temperature Controller information, refer to that unit's catalog. Serial data transfer option types use a "7" for RS-232C, and "5" for RS-422 - 2 wire.

*2 Except for GP377 Series units, all GP70 Series and GLC100 Series units cannot be connected.

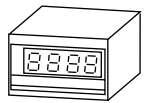
■ SD16 Series

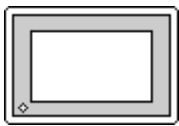

Controller *1	Cable Diagram	GP/GLC
		
SD16-□□□-□□7□	RS-232C (Cable Diagram 2)	GP Series GLC Series *2
SD16-□□□-□□5□	RS-422 2-wire (Cable Diagram 7)	
	RS-422 2-wire 1:n Connection (Cable Diagram 8)	

*1 The model data "□" will vary depending on the type of option.

For detailed temperature Indicator information, refer to that unit's catalog.
 Serial data transfer option types use a "7" for RS-232C, and "5" for RS-422 - 2 wire.

*2 Except for GP377 Series units, all GP70 Series and GLC100 Series units cannot be connected.

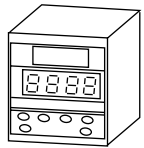
■ EM70 Series

Controller *1	Cable Diagram	GP/GLC
		
EM70-□□-□□□7□	RS-232C (Cable Diagram 2)	GP Series GLC Series *2
EM70-□□-□□□5□	RS-422 2-wire (Cable Diagram 7)	
	RS-422 2-wire 1:n Connection (Cable Diagram 8)	

*1 The model data "□" will vary depending on the type of option.

For detailed temperature Controller information, refer to that unit's catalog.
 Serial data transfer option types use a "7" for RS-232C, and "5" for RS-422 - 2 wire.

*2 Except for GP377 Series units, all GP70 Series and GLC100 Series units cannot be connected.

◆ Connections

• 1:1 connection

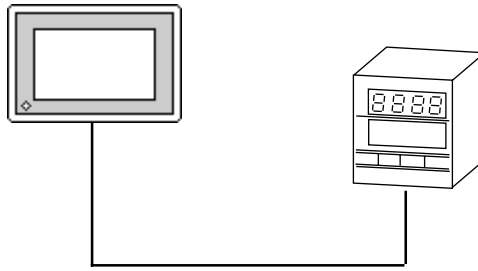

• 1:n connection

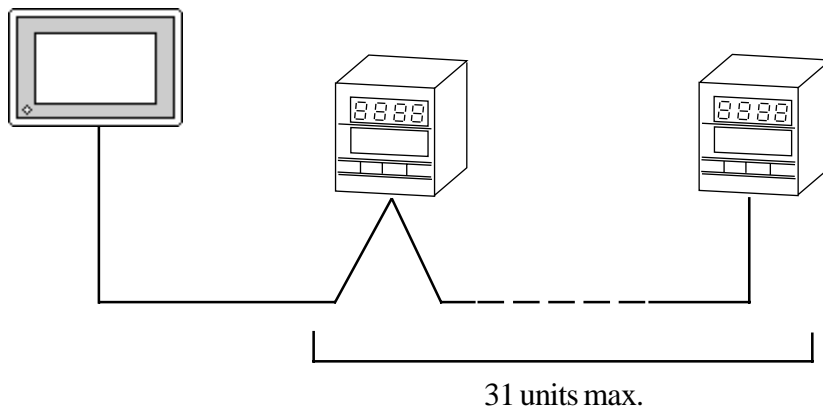

12.4.2 Cable Diagrams

The cable diagrams shown below and the cable diagrams recommended by RKC INSTRUMENT INC. may differ, however, using these cables for your Controller's operations will not cause any problems.



- **Ground your Controller's FG terminal according to your country's applicable standard. For details, refer to your Controller's manual.**
- **When connecting a cable's Shield line to an FG terminal, consider the needs of your system when deciding which side of the cable (GP/GLC or Controller) to connect. (The example below connects to the Controller's FG terminal.)**
- **If a communications cable is used, be sure to connect its SG (signal ground) terminal.**
- **RS-232C cables should be 15 meters or less.**
- **RS-422 (2-wire) cables should be 500 meters or less.**
- **RS-422 (4-wire) cables should be 600 meters or less.**
- **When using an RS-422 connection, be sure to use the following method to insert termination resistance.**

SR253 Series Units (4-wire)

Internally 270Ω of resistance is available. Turn the Controller's internal SW1a and SW1b switches ON.

SR253 Series Units (2-wire)

Internally 135Ω of resistance is available. Turn the Controller's internal switch ON.

SR90/SR80/MR13/FP93/SD16/EM70 Series Units

On the final node's terminal block, between the "+" and "-" terminals, attach a 1/2W 120Ω of termination resistance.

Cable Diagram 1 (1:1) RS-232C

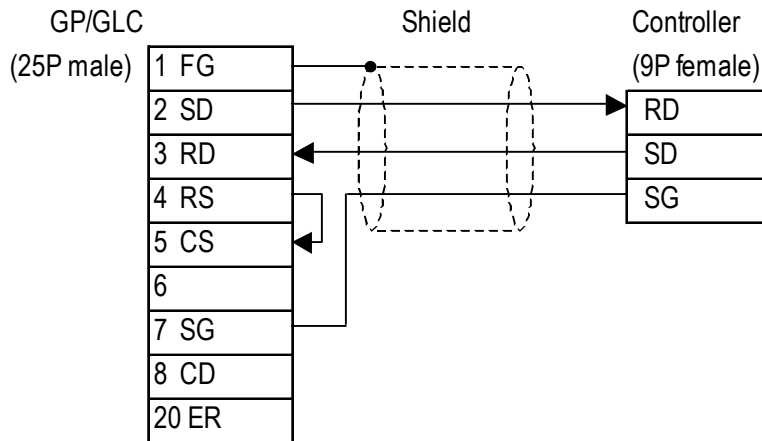

Cable Diagram 2 (1:1) RS-232C

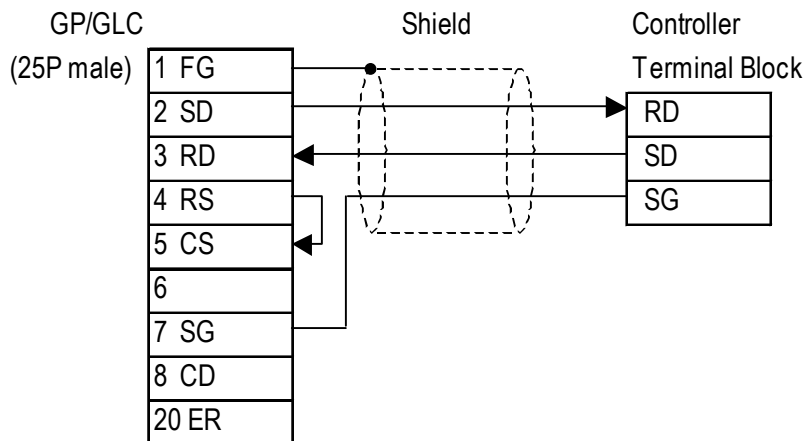

Controller Terminal Block Numbers

	SR92	SR82	SR83	SR84	SD16	EM70
	SR93		MR13			
	SR94		FP93			
RD	3	18	25	22	17	28
SD	2	17	24	21	16	27
SG	1	16	23	1	15	26

Cable Diagram 3 (1:1) RS-422 4-Wire

<When using Digital's RS-422 connector terminal adapter GP070-CN10-0>

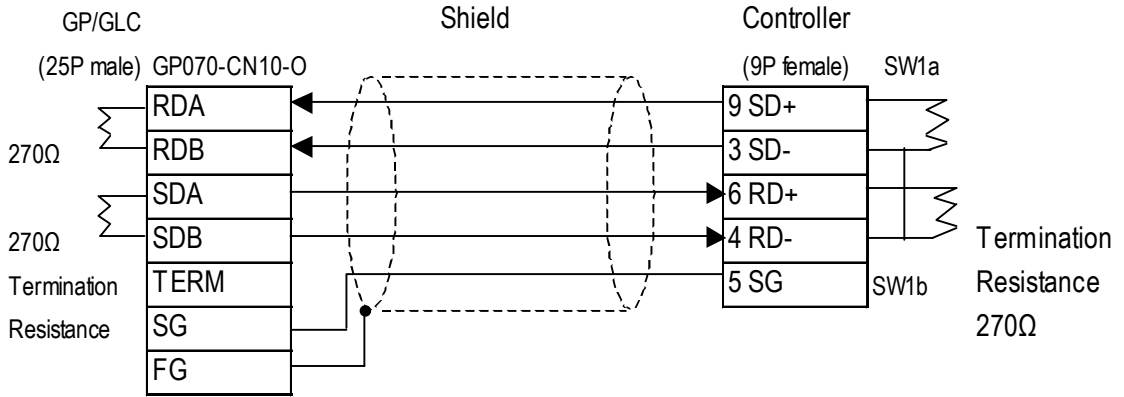

<When making your own cable>

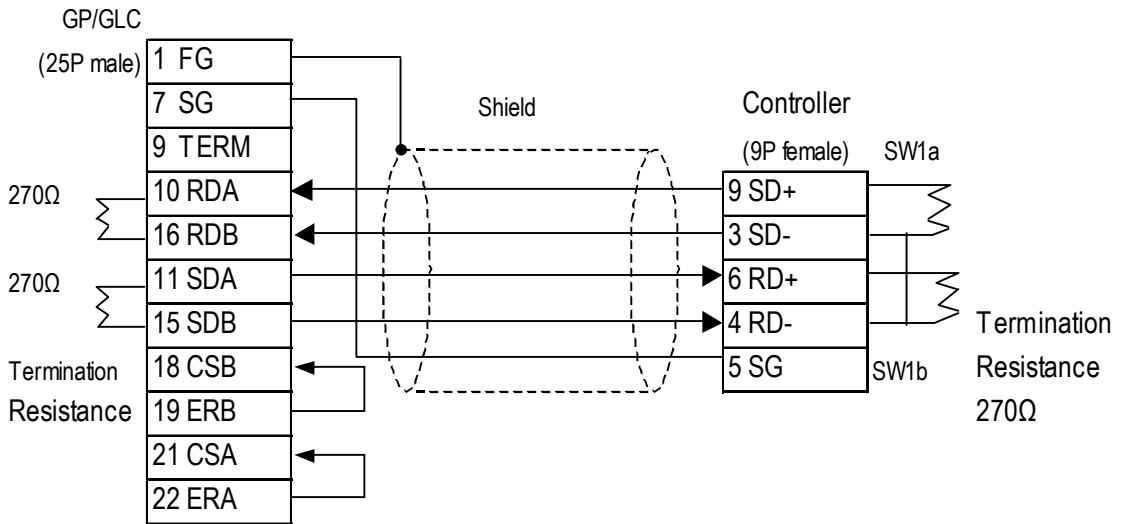

Cable Diagram 4 (1:n) RS-422 4-Wire

<When using Digital's RS-422 connector terminal adapter GP070-CN10-0>

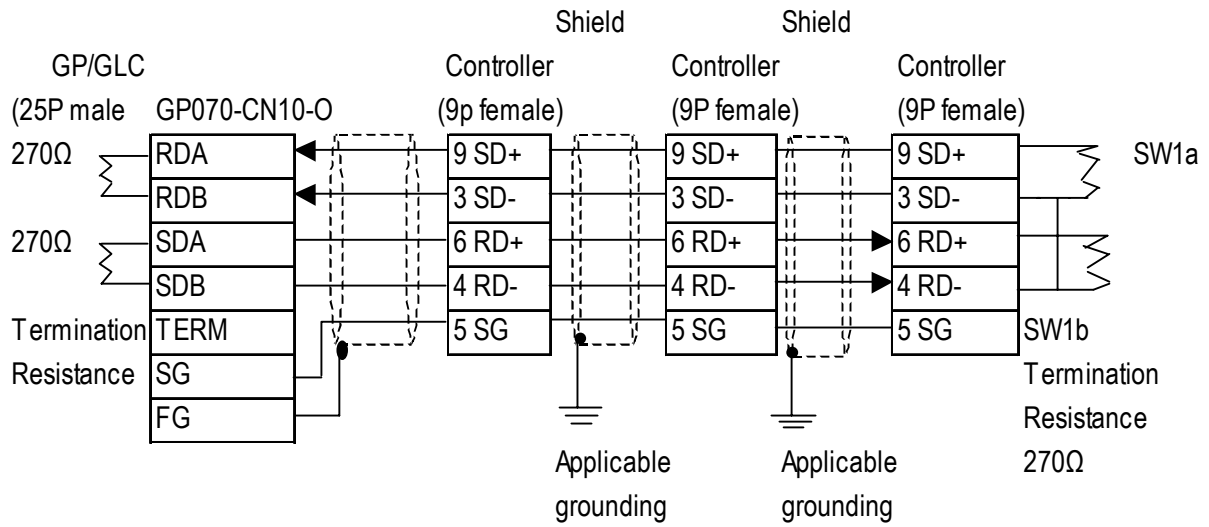

<When making your own cable>

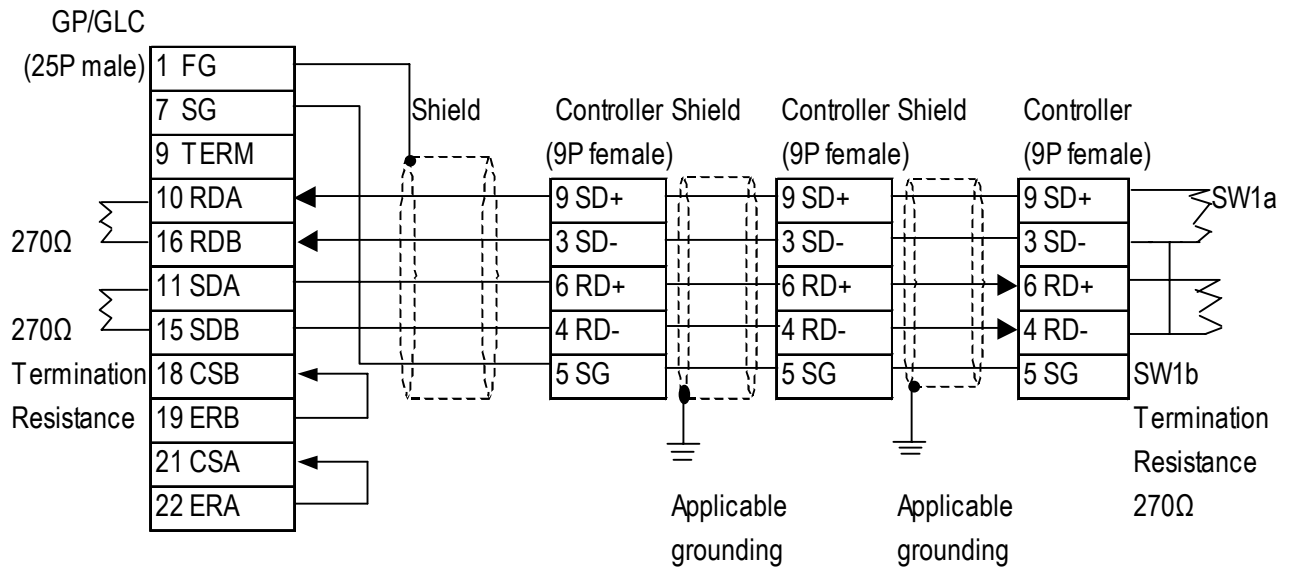

Cable Diagram 5 (1:1) RS-422 2-Wire

<When using Digital's RS-422 connector terminal adapter GP070-CN10-0>

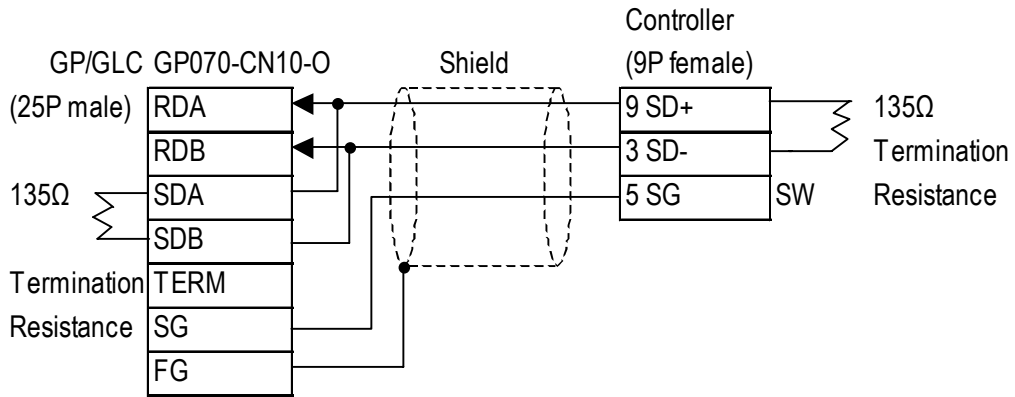

<When making your own cable>

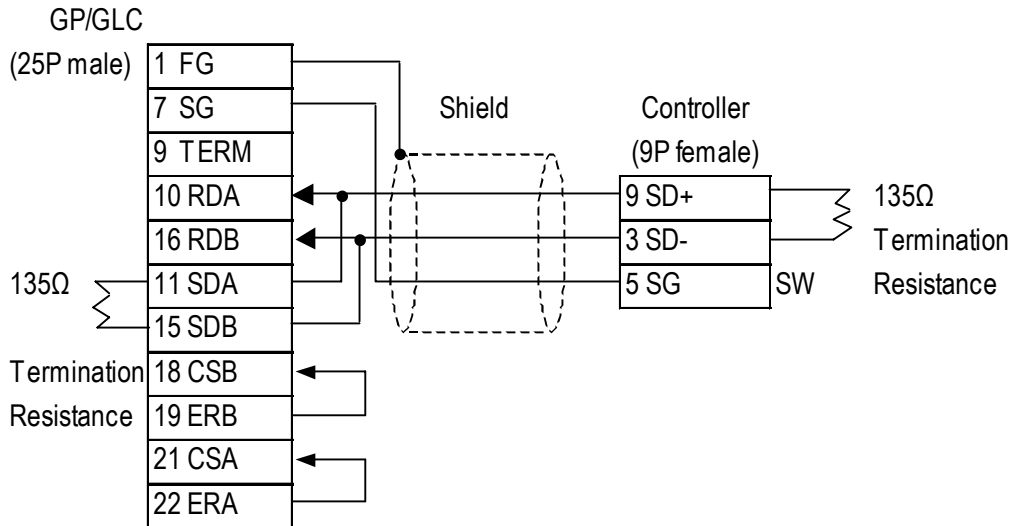

Cable Diagram 6 (1:n) RS-422 2-Wire

<When using Digital's RS-422 connector terminal adapter GP070-CN10-0>

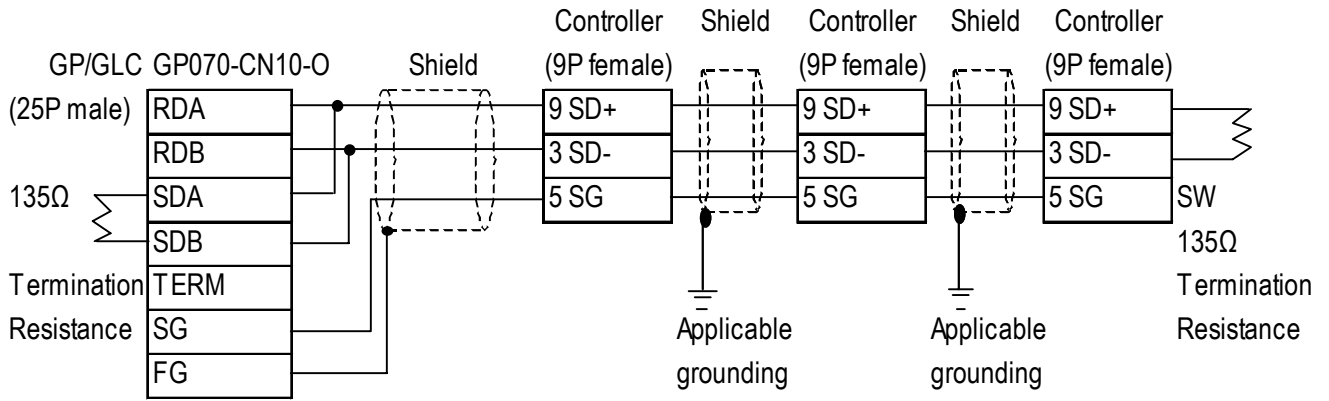

<When making your own cable>

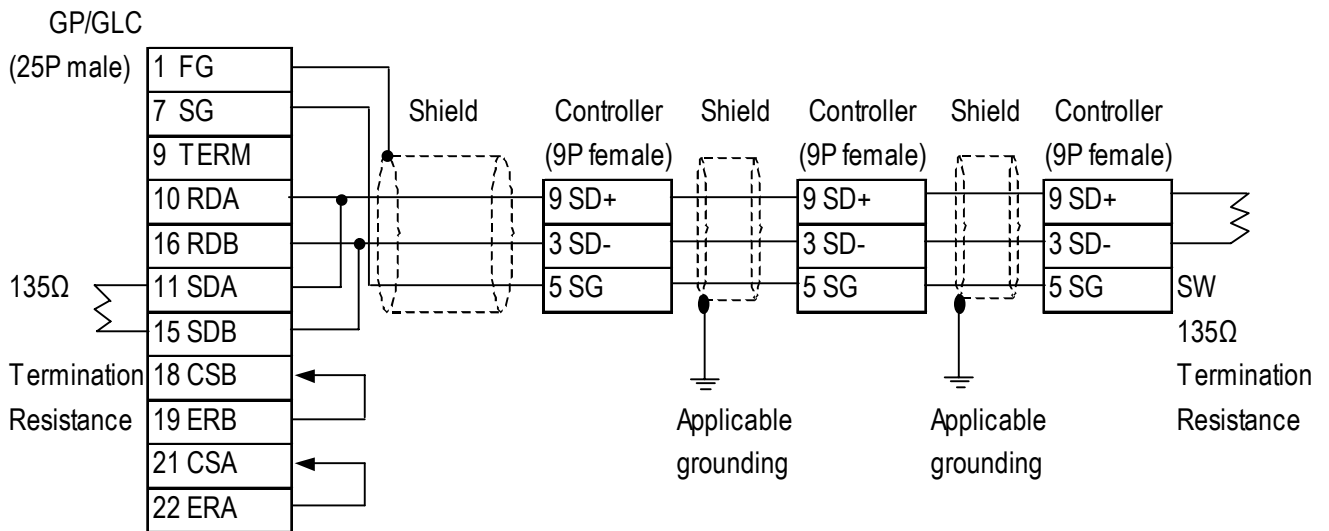

Cable Diagram 7 (1:1) RS-422 2-Wire

<When using Digital's RS-422 connector terminal adapter GP070-CN10-0>

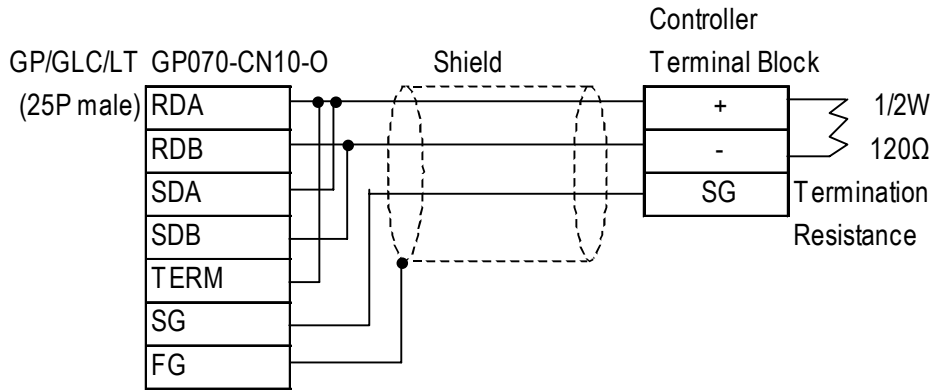

<When using Digital's RS-422 cable GP230-IS11-0>

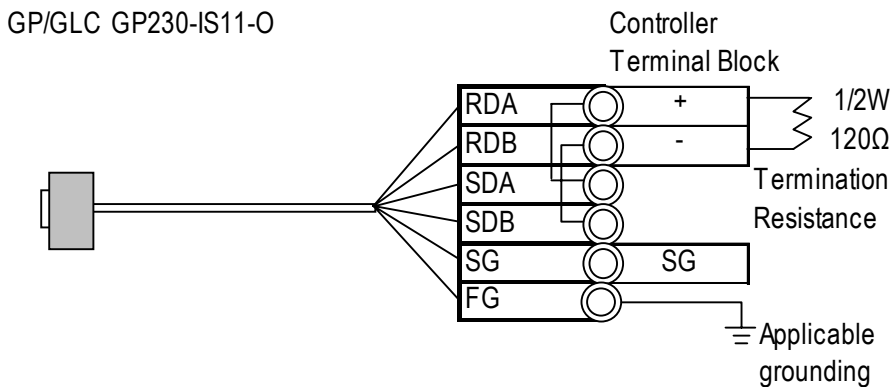

<When making your own cable>

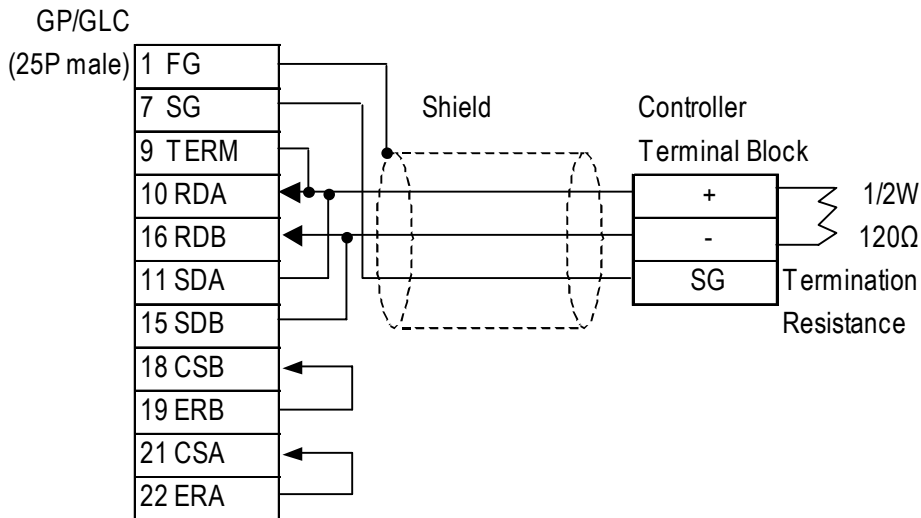

Controller Terminal Block Numbers

	SR91	SR92 SR93 SR94	SR82	SR83 MR13 FP93	SR84	SD16	EM70
+	11	2	17	24	21	16	27
-	12	3	18	25	22	17	28
SG	1	1	16	23	1	15	26

Cable Diagram 8 (1:n) RS-422 2-Wire

<When using Digital's RS-422 connector terminal adapter GP070-CN10-0>

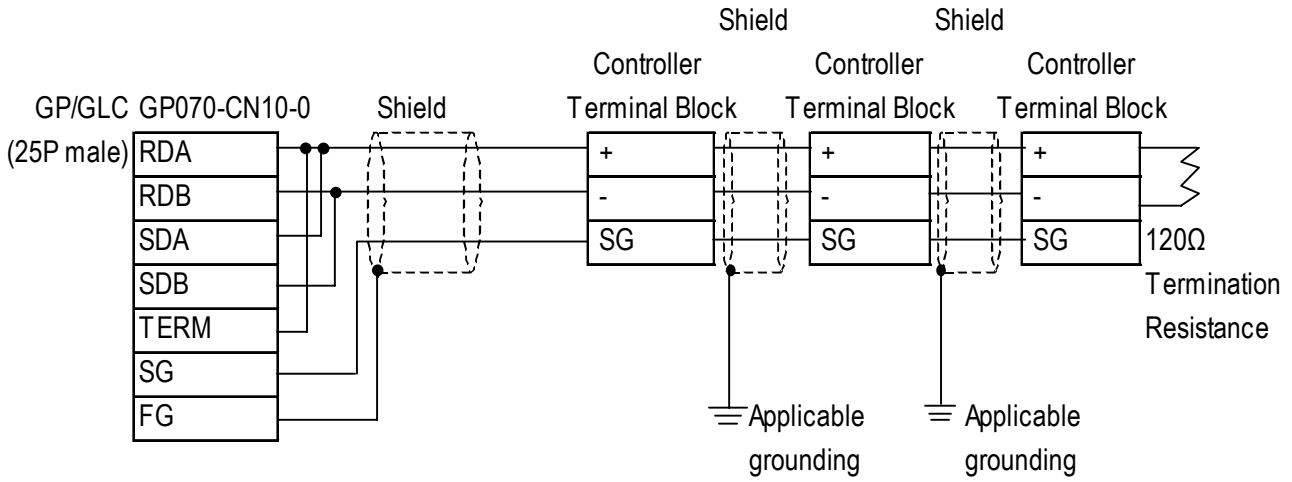

<When using Digital's RS-422 cable GP230-IS11-0>

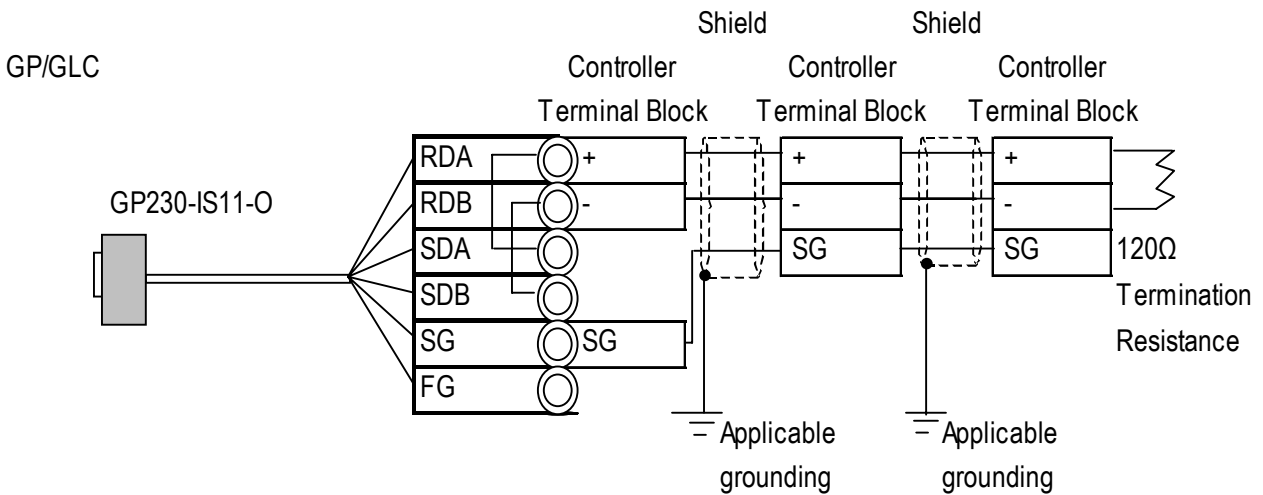

<When making your own cable>

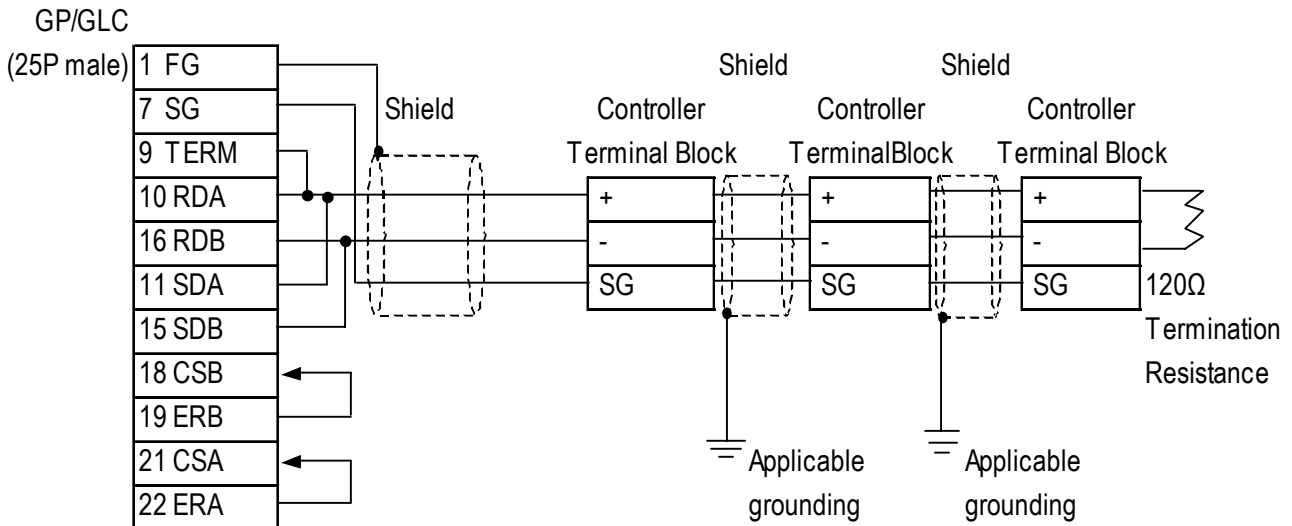

Controller Terminal Block Numbers

	SR91	SR92 SR93 SR94	SR82	SR83 MR13 FP93	SR84	SD16	EM70
+	11	2	17	24	21	16	27
-	12	3	18	25	22	17	28
SG	1	1	16	23	1	15	26

12.4.3 Supported Devices

The following list shows the range of devices supported by the GP/GLC.

SR253/SR90/SR80/MR13/FP93/SD16/EM70 Series

Device	Bit Address	Word Address	Comments	
Data Address	_____	0020~03FF	<input type="checkbox"/> Bit F *1*2*3	H/L
	_____	0400~07FF		
	_____	0800~0BFF		
	_____	0C00~0D7F		

*1 Depending on the series model used, certain addresses do not exist and/or devices may not be able to be read from or written to. For details, please refer to your Temperature Controller's Installation Guide.

*2 Data addresses 0200H to 021FH are double word addresses. If they are not used according to the conditions given below, Host Communication Error 08 will occur.

-All data addresses used must be even. (Ex. 0200, 0202, etc.)

-All data to be read out must be designated using even numbers. (Ex. 2, 4, etc.)

Usage Example: When using the "Numeric Display Settings" Part to display data and reading from data address 0X200, be sure to set "Data Display Format" to 32-bit. If the data is designated as 16-bit, Host Communication Error 08 will occur.

*3 File registers are each 1,024 words on your GP/GLC application.

You cannot extend over more than a single data "block" when performing the following features.

Be sure to set these features' settings so they are within a single data block.

- 1) "a-tag " settings
- 2) Performing Block read/write from Pro-Server
- 3) Designating the "Convert from" and "Convert to" address for the "Address Conversion" features



• **GP/GLC's System Area (LS0 to LS19) Settings**

The GP/GLC's system area (20 words) cannot be allocated to the Controller's own data area. When you are entering the system area settings via the screen editor software or via the GP/GLC's OFFLINE screen, be careful that you do not use the Controller's own data area.

- With system versions later than the following, even if the system area is allocated, the GP/GLC will not send the system area data to a Controller. To check the system version, refer to the GP/GLC's User Manual.

GP/GLC Series	GP77R	GP377	GP2000	GLC300	GLC2000
System Version	Ver.2.69	Ver.2.69b	Ver.3.50g	Ver.2.69	Ver.3.50g



- Indicating Controller Slave Address settings can be entered in your screen editor software. If a unit number is not indicated, the previously entered station number is automatically used. (The default value is 1.)

E.g. When entering Device Address 02EE

Enter the Device Name "...", and the Word Address "02EE".

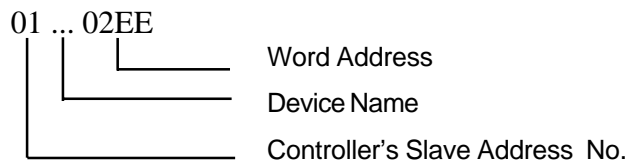

12.4.4 Environment Setup

The following table lists Digital's recommended Shimaden Co., Ltd. Controller and GP/GLC communication settings.



- ***The Temperature Controller's default data transfer speed is 1200bps. When using this unit, speeds from 2400bps to 19,200bps can be used.***
- ***The Temperature Controller's Memory Mode default setting is EEP(EEPROM). Since the number of times the EEPROM can be overwritten is fixed, try to reduce the number of times you write/overwrite data to the EEPROM.***
- ***The Temperature Controller's data transfer settings are set via the front face keys. For details, refer to your Temperature Controller's Installation Guide.***
- ***When using RS232C or RS422 2-wire communication cables, a Send Wait of over 20ms is required. If a wait of less than this is used, a communication error (PLC not responding 02:FE:** or Error in received data 02:FD:**) may occur. Be sure the Send Wait setting is 20ms or longer in your screen editor program. The default value of "0" means the program will internally insert a Send Wait of 20ms.***

■ SR253 Series

GP/GLC Settings		Controller Settings	
Baud Rate	19200bps	Communication Rate (BPS)	19200bps
Data Length	7bits	Communication Data Format (DATA)	7E1
Stop Bit	1bit		
Parity Bit	even		
Data Flow Control	ER	_____	_____
Communication Format When using RS-232C	RS-232C	Communication Format	RS-232C
Communication Format When using RS-422	RS-422 2-wire	Communication Format	RS-485
Communication Format When using RS-422	RS-422 4-wire	Communication Format	RS-422A
_____	_____	Communication Protocol Mode (Mode)	Standard
_____	_____	CONTROL (Operation)	LOCAL
_____	_____	Control Codes (CTRL)	STX_ETX_CR
_____	_____	Check Sum (BCC)	Add
_____	_____	Delay Time (DELY)	0
_____	_____	Communication Memory Mode (MEM)	EEP
Unit No.	1~31	Machine Address (Add)	01~31



- **The [CONTROL Operation] feature is used to set whether the Controller's parameter setting changes are performed via the external device (GP/GLC/LT) or via the Controller. These are indicated using the "LOCAL" (Controller) and "COMMU" (GP/GLC) selections.**
- **"Delay Time DELY" designates the time from when a command is received from the GP/GLC/LT to when the Controller responds. Please set this value to "0". (Delay Time (ms) = setting value *0.25(ms))**
- **The Controller's machine address number range is from 0 to 99 for the SR253 Series units. Use only from 1 to 31 on the GP/GLC.**
- **With a 1:n connection, up to 31 SR253 Series units can be connected to a single GP/GLC.**

■ SR90 Series

GP/GLC Settings		Controller Settings	
Baud Rate	19200bps	Communication Rate (bPS)	19200bps
Data Length	7bits	Communication Data Format (dAtA)	7E1
Stop Bit	1bit		
Parity Bit	even		
Data Flow Control	ER	_____	_____
Communication Format When using RS-232C	RS-232C	Communication Format	RS-232C
Communication Format When using RS-422	RS-422 2-wire	Communication Format	RS-485
_____	_____	Communication Mode (Comm)	Loc
_____	_____	Start Character (SchA)	Stx
_____	_____	BCC check (bcc)	1
_____	_____	Delay Time (dELY)	1
_____	_____	Memory Mode (mEm)	EEP
Unit No.	1~31	Communication Address (Addr)	01~31



- **The [Communication Mode] feature is used to set whether the Controller's parameter setting changes are performed via the external device (GP/GLC/LT) or via the Controller. These are indicated using the "LOCAL" (Controller) and "COMMU" (GP/GLC) selections.**
- **"Delay Time DELY" designates the time from when a command is received from the GP/GLC/LT to when the Controller responds. Please set this value to "1". (Delay Time (ms) = setting value *0.512(ms))**
- **The Controller's Communication address number range is from 0 to 255 for the SR90 Series units. Use only from 1 to 31 on the GP/GLC.**
- **With a 1:n connection, up to 31 SR90 Series units can be connected to a single GP/GLC.**

■ SR80 Series

GP/GLC Settings		Controller Settings	
Baud Rate	19200bps	Communication Rate (bPS)	19200bps
Data Length	7bits	Communication Data Format (dAtA)	7E1
Stop Bit	1bit		
Parity Bit	even		
Data Flow Control	ER	_____	_____
Communication Format When using RS-232C	RS-232C	Communication Format	RS-232C
Communication Format When using RS-422	RS-422 2-wire	Communication Format	RS-485
_____	_____	Communication Mode (Comm)	Loc
_____	_____	Control Code (Ctrl)	1
_____	_____	BCC check (bcc)	1
_____	_____	Delay Time (dELY)	1
_____	_____	Memory Mode (mEm)	EEP
Unit No.	1~31	Communication Address (Adrs)	01~31



- **The [Communication Mode] feature is used to set whether the Controller’s parameter setting changes are performed via the external device (GP/GLC) or via the Controller. These are indicated using the “LOCAL” (Controller) and “COMMU” (GP/GLC) selections.**
- **“Delay Time DELY” designates the time from when a command is received from the GP/GLC/LT to when the Controller responds. Please set this value to “1”. (Delay Time (ms) = setting value *0.512(ms))**
- **The Controller’s Communication address number range is from 0 to 99 for the SR80 Series units. Use only from 1 to 31 on the GP/GLC.**
- **With a 1:n connection, up to 31 SR80 Series units can be connected to a single GP/GLC.**

■ MR13 Series

GP/GLC Settings		Controller Settings	
Baud Rate	19200bps	Communication Speed (bPS)	19200bps
Data Length	7bits	Communication Data Format (dEFm)	7E1
Stop Bit	1bit		
Parity Bit	even		
Data Flow Control	ER	_____	_____
Communication Format When using RS-232C	RS-232C	Communication Format	RS-232C
Communication Format When using RS-422	RS-422 2-wire	Communication Format	RS-485
_____	_____	Communication Mode (mod)	Loc
_____	_____	Control Code (Ctrl)	1
_____	_____	Check Sum (bCC)	1
_____	_____	Delay Time (dELY)	0
_____	_____	Memory Mode (mEm)	EEP
Unit No.	1~31	Communication Address (Addr)	01~31



- **The [Communication Mode] feature is used to set whether the Controller's parameter setting changes are performed via the external device (GP/GLC) or via the Controller. These are indicated using the "LOCAL" (Controller) and "COMMU" (GP/GLC) selections.**
- **"Delay Time DELY" designates the time from when a command is received from the GP/GLC to when the Controller responds. Please set this value to "0". (Delay Time (ms) = setting value *0.25(ms))**
- **The Controller's Communication address number range is from 0 to 99 for the MR13 Series units. Use only from 1 to 31 on the GP/GLC.**
- **With a 1:n connection, up to 31 MR13 Series units can be connected to a single GP/GLC.**

■ FP93 Series

GP/GLC/LT Settings		Controller Settings	
Baud Rate	19200bps	Communication Rate (bPS)	19200bps
Data Length	7bits	Communication Data Format (dEFm)	7E1
Stop Bit	1bit		
Parity Bit	even		
Data Flow Control	ER	_____	_____
Communication Format When using RS-232C	RS-232C	Communication Format	RS-232C
Communication Format When using RS-422	RS-422 2-wire	Communication Format	RS-485
_____	_____	Communication Mode (Comm)	Loc
_____	_____	Start Character (SchA)	Stx
_____	_____	Check Sum (bcc)	1
_____	_____	Delay Time (dELY)	1
_____	_____	Memory Mode (mEm)	EEP
Unit No.	1~31	Communication Address (Addr)	01~31



- **The [Communication Mode] feature is used to set whether the Controller's parameter setting changes are performed via the external device (GP/GLC) or via the Controller. These are indicated using the "LOCAL" (Controller) and "COMMU" (GP/GLC) selections.**
- **"Delay Time DELY" designates the time from when a command is received from the GP/GLC/LT to when the Controller responds. Please set this value to "1". (Delay Time (ms) = setting value *0.512(ms))**
- **The Controller's Communication address number range is from 0 to 255 for the FP93 Series units. Use only from 1 to 31 on the GP/GLC.**
- **With a 1:n connection, up to 31 FP93 Series units can be connected to a single GP/GLC.**

■ SD16 Series

GP/GLC Settings		Controller Settings	
Baud Rate	19200bps	Communication Rate (bPS)	19200bps
Data Length	7bits	Communication Data Format (dAtA)	7E1
Stop Bit	1bit		
Parity Bit	even		
Data Flow Control	ER	_____	_____
Communication Format When using RS-232C	RS-232C	Communication Format	RS-232C
Communication Format When using RS-422	RS-422 2-wire	Communication Format	RS-485
_____	_____	Communication Mode (Comm)	Loc
_____	_____	Start Character (SchA)	Stx
_____	_____	Delay Time (dELY)	0
Unit No.	1~31	Machine Address (Addr)	01~31



- **The [Communication Mode] feature is used to set whether the Indicator's parameter setting changes are performed via the external device (GP/GLC) or via the Indicator. These are indicated using the "LOCAL" (Indicator) and "COMMU" (GP/GLC) selections.**
- **"Delay Time DELY" designates the time from when a command is received from the GP/GLC to when the Indicator responds. Please set this value to "0". (Delay Time (ms) = setting value *0.1(ms))**
- **The Indicator's Communication address number range is from 0 to 255 for the SD16 Series units. Use only from 1 to 31 on the GP/GLC.**
- **With a 1:n connection, up to 31 SD16 Series units can be connected to a single GP/GLC.**

■ EM70 Series

GP/GLC Settings		Controller Settings	
Baud Rate	19200bps	Communication Rate (b.)	19200bps
Data Length	7bits	Communication Data Format (dt.)	7E1
Stop Bit	1bit		
Parity Bit	even		
Data Flow Control	ER	_____	_____
Communication Format When using RS-232C	RS-232C	Communication Format	RS-232C
Communication Format When using RS-422	RS-422 2-wire	Communication Format	RS-485
_____	_____	Communication Mode (Com)	L
_____	_____	Control Code (Ctl.)	1
_____	_____	Check Sum (bCC.)	1
_____	_____	Delay Time (dL.)	0
_____	_____	Memory Mode (m.)	EEP
Unit No.	1~31	Communication Address (Adr.)	01~31



- **The [Communication Mode] feature is used to set whether the Controller's parameter setting changes are performed via the external device (GP/GLC) or via the Controller. These are indicated using the "LOCAL" (Controller) and "COMMU" (GP/GLC) selections.**
- **"Delay Time DELY" designates the time from when a command is received from the GP/GLC to when the Controller responds. Please set this value to "0". (Delay Time (ms) = setting value *0.25(ms))**
- **The Controller's Communication address number range is from 0 to 99 for the EM70 Series units. Use only from 1 to 31 on the GP/GLC.**
- **With a 1:n connection, up to 31 EM70 Series units can be connected to a single GP/GLC.**

12.45 Error Codes

■ Controller Error Codes

Error messages (Ex. Host communication error (02:**:##)) are displayed in the lower left corner of the GP/GLC screen (** stands for an error code specific to the Controller).

Host Communication Error (02:**:##)

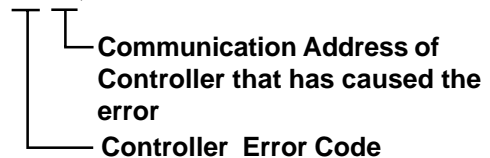

Error Code	Type of Code	Description
01*1	Text section's hardware error	A "Framing overrun", "Parity" or other type of hardware error has been detected in the text section.
07	Text section's format error	Format of this section's data does not agree with the defined format.
08	Text section's data format, data address or data amount error	Format of this section's data does not agree with the defined format, or the data address or amount exceeds the designated value(s).
09	Data error	The write data exceeds the set range for that data.
0A	RUN (Execute) Command Error	An execute command (MAN command, etc.) was received while execute commands were not being accepted.
0B	Write Mode Error	When the data overwrite command is issued, this error will occur if LOCAL mode is selected and the Text section contains a type of data that cannot be accepted.
0C	Specification, Option Error	When a write command is received that contains no specification or option data, this error will occur.

*1 MR13 Series and SD16 Series units do not have this error code.

Refer to the Controller's manual for error code details.

A1

Maximum Number of Consecutive PLC Addresses

The following lists the maximum number of consecutive addresses that can be read by each PLC. Refer to these tables to utilize *Block Transfer*.

SR253/SR90/SR80/MR13/FP93/SD16/EM70 Series

Device	Max No. of Consecutive Address
Data Address	10 Words

A2

Device Codes and Address Codes

Device codes and address codes are used to specify indirect addresses for E-tags and K-tags.

SR253/SR90/SR80/MR13/FP93/SD16/EM70 Series

Device	Word Address (HEX)	Device Code (HEX)	Address Code (HEX)
Data Address	0020~03FF	0200	Word Address - 0020
	0400~07FF	0400	Word Address - 0400
	0800~0BFF	0600	Word Address - 0800
	0C00~0D7F	0800	Word Address - 0C00

A3**Address Conversion Table**

Refer to the following Address Conversion Table to convert addresses correctly.

○: When the selected conversion mode is [Word], both word and bit addresses are converted. When the [Bit] is selected, only bit addresses are converted.

SR253/SR90/SR80/MR13/FP93/SD16/EM70 Series

		After Conversion	
		Data Address	LS Area
Before Conversion	Data Address	○	○
	LS Area	○	○