

GP-PRO/PBIII for Windows
Device/PLC CONNECTION MANUAL
ADDITIONAL MANUAL

Siemens Corporation PLC

Pro-face
Human Machine Interface —

Reading the GP-PRO/PBIII Device/PLC Connection Manual

This document is designed as an addition to the latest GP-PRO/PBIII for Windows Device/PLC Connection manual's Siemens Corporation data.

When connecting a Factory Gateway unit, please substitute the words "Factory Gateway" for this document's "GP/GLC".

Installation

This CD-ROM includes all the protocol files required by the GP/GLC to communicate with a Siemens Corporation S7 200/300/400 Series PLCs. Also, you will need to have one or more of the following software applications installed. The screen and data transfer files included in the CD-ROM must be installed in each of those applications. For information regarding installing the software, refer to that software's Operation Manual.

■ Software Applications

- GP-PRO/PBIII for Windows Ver. 7.0 or higher.
- Pro-Server with Pro-Studio for Windows Ver. 4.1 ^{*1}

- 1) Be sure to confirm that the required software application is installed in your PC prior to starting installation.
- 2) Double-click the CD-ROM's "s7_mpi.exe" file to start the installation process.
- 3) Once the installation program starts, follow the instructions given to install the protocol files.



- ***When using GP-PRO/PBIII for Windows, be sure to select [Device/PLC Type] - [Siemens] - [Siemens S7-200 via MPI] or [Siemens S7-300/400 via MPI].***

**1 When using the Factory Gateway unit, GP-Web Ver. 1.0 or later or GP-Viewer Ver. 1.0 or later, be sure to select "Pro-Server with Pro-Studio for Windows" as the "Destination Folder".*





2.16 Siemens

2.16.1 System Structure

The following describes the system structure for connecting the GP to Siemens PLCs.

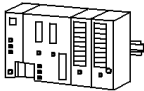
Reference The Cable Diagrams mentioned in the following tables are listed in the section titled "2.16.2 Cable Diagrams".

■ SIMATIC S5 Series (using Link I/F <3964/3964R via RK512 Protocol>)



CPU	Link I/F	Cable Diagram	GP
			
90U, 95U, 100U	CP521 S1	RS-232C (Cable Diagram 1)	GP Series
115U	CP524 CP525		
115U (CPU944)	CPU unit Link I/F ^{*1}		
135U, 155U	CP524 CP525		
135U, 155U (CPU928B)	CPU unit Link I/F ^{*1}		

*1 Connect to SI2 Port.

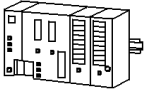

- Supports both 3964 and 3964R protocols. The GP automatically discriminates between the two. For better error detection, the 3964R is recommended.
- The PLC must be running a communication type ladder program to share data with the Device/PLC.

■ **SIMATIC S5 Series (CPU Direct)**



CPU ¹	Cables	GP
		
90U, 95U, 100U (CPU100/102/103), 115U (CPU941/942/943/ 944), 135U/155U (CPU922/928/928B)	Digital's current loop converter ² GP000-IS11-O	GP Series ^{*3}

*1 Connect to the Programming port.

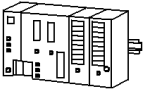

*2 Due to the size of its connector, this cable cannot be used for GP-270, GP-370, and GP-377R series units.

*3 Cannot be connected to GP2000, GLC2000 and ST Series units.

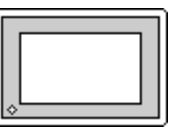
■ **SIMATIC S7-200 Series (PPI Connection)**

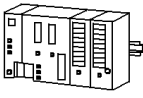

CPU	Cables	GP
		
CPU212, CPU214	RS422 (Cable Diagram 2)	GP Series

■ **SIMATIC S7-200 Series (MPI Direct)**

CPU	Cables	GP
		
CPU214, CPU215, CPU216, CPU221, CPU222, CPU224, CPU226	RS-422 (Cable Diagram 10) RS-422 1:n Communication (Cable Diagram 11) RS-422 n:1 Communication (Cable Diagram 12)	GP/GLC Series

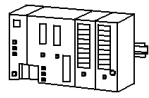

*1 Refer to this section's  Connectable GP/GLC units for SIMATIC S7-200/300/400 Series (MPI Direct).

■ **SIMATIC S7-300 Series (MPI Direct)**

CPU	Cable Diagram	GP
		
CPU312IFM CPU313 CPU314	RS-422 (Cable Diagram 10)	GP/GLC Series ¹
CPU314IFM CPU315 CPU315-2DP	RS-422 1:n Communication (Cable Diagram 11)	
CPU316 CPU316-2DP	RS-422 n:1 Communication (Cable Diagram 12)	
CPU318-2		

**1 Refer to this section's ♦Connectable GP/GLC units for SIMATIC S7-200/300/400 Series (MPI Direct).*

■ **SIMATIC S7-400 Series (MPI Direct)**

CPU	Cable Diagram	GP
		
CPU412-1 CPU412-2DP CPU413-1 CPU413-2DP	RS-422 (Cable Diagram 10)	GP/GLC Series ¹
CPU414-1 CPU414-2DP CPU414-3DP	RS-422 1:n Communication (Cable Diagram 11)	
CPU416-1 CPU416-2DP CPU416-3DP CPU-417-4	RS-422 n:1 Communication (Cable Diagram 12)	

**1 Refer to this section's ♦Connectable GP/GLC units for SIMATIC S7-200/300/400 Series (MPI Direct).*

◆ **Connectable GP/GLC units for SIMATIC S7-200/300/400 Series**
(MPI Direct)

Series Name		Product Name	187500bps *1	
GP70 Series	GP-377 Series	GP-377-LG41-24V	Rev. J or higher	
		GP-377-SC41-24V	Rev. J or higher	
	GP-37W2 Series	GP-37W2B	Rev. L or higher	
GP77R Series	GP-377R Series	GP-377RT	—	
	GP-477R Series	GP-477RE	—	
	GP-577R Series	GP-577RS	—	
		GP-577RT	—	
GP2000 Series	GP-2300 Series	GP-2300L	Rev. I or higher	
		GP-2300S	All Rev.	
		GP-2300T	Rev. I or higher	
	GP-2301 Series	GP-2301L	Rev. I or higher	
		GP-2301S	Rev. I or higher	
		GP-2301T	All Rev.	
	GP-2400 Series	GP-2400T	Rev. H or higher	
	GP-2401 Series	GP-2401T	All Rev.	
	GP-2500 Series	GP-2500L	Rev. B or higher	
		GP-2500S	Rev. A or higher	
		GP-2500T (Only GP2500-TC41-24V)	Rev. C or higher	
	GP-2501 Series	GP-2501S	Rev. A or higher	
		GP-2501T	Rev. A or higher	
	GP-2600 Series	GP-2600T (Only GP2600-TC41-24V)	Rev. C or higher	
	GP-2601 Series	GP-2601T	All Rev.	
	GP2000H Series	GP-2301H Series	GP-2301HL	All Rev.
			GP-2301HS	All Rev.
GP-2401H Series		GP-2401HT	All Rev.	
GLC2000 Series	GLC2300 Series	GLC-2300L	Rev. I or higher	
		GLC-2300T	Rev. I or higher	
	GLC2400 Series	GLC-2400T	Rev. E or higher	
	GLC2500 Series	GLC-2500T	All Rev.	
	GLC2600 Series	GLC-2600T	Rev. A or higher	
ST Series	ST400 Series	ST402	All Rev.	

*1 When using a unit that cannot operate at 187500bps, be sure to select another data transfer speed. **Reference** 2.16.4 Environment Setting Example



- **When transferring data using a GLC2000 unit at 187500bps, be sure to either set the Ladder Scan Time to 8 times longer than the Logic Time, or set the Percent Scan at 10%.**
- **For setting information, refer to your "Pro-Control Editor User Manual".**

◆ Connection Structure

1:n RS-422 2-wire type

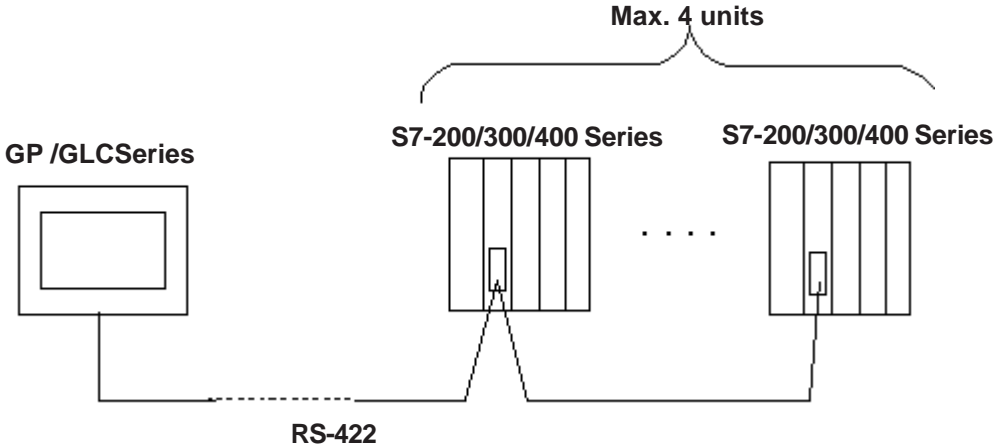

n:1 RS-422 2-wire type

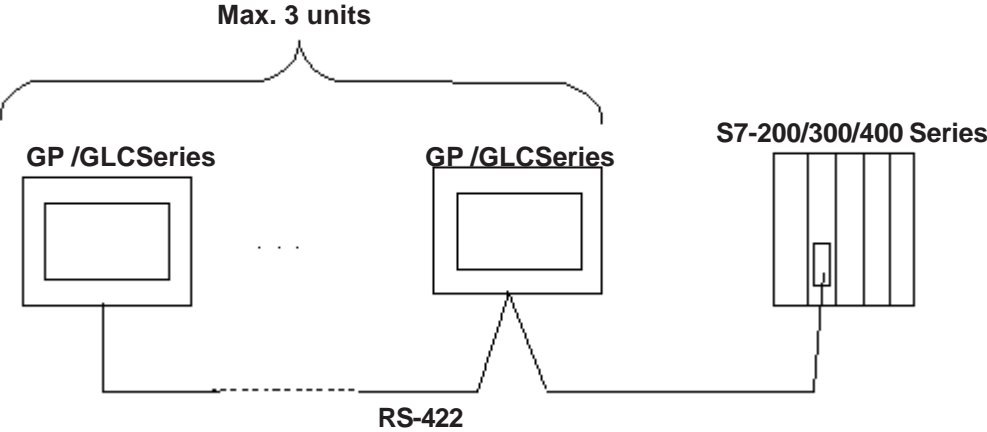

n:m RS-422 2-wire type

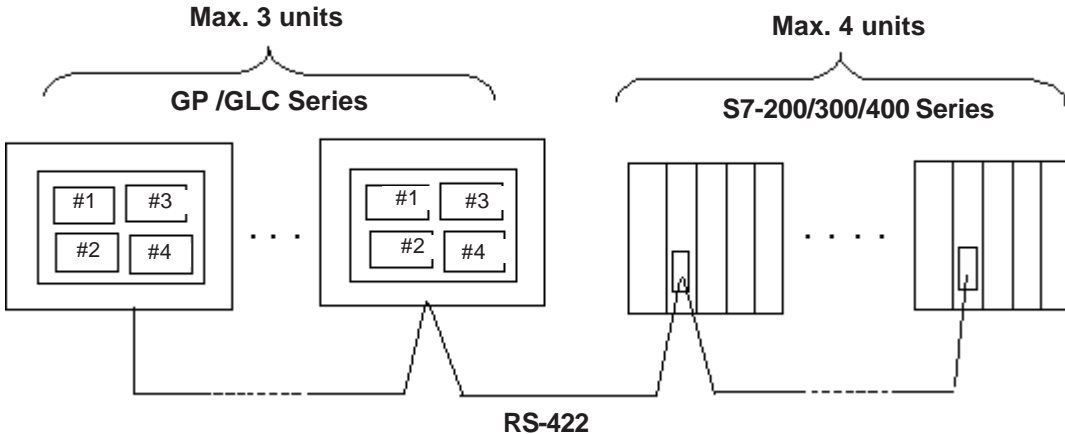



* The connections 1:n and n:1 can be made on the same line.



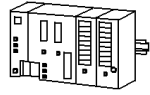

Note: For details about MPI Network, refer to Siemens's Manual.





■ **SIMATIC S7-300 Series (MPI via adapter)**

CPU	Link I/F	GP
		
CPU312IFM, CPU313, CPU314, CPU315, CPU315-2DP	Digital's GP070-MPI-41	GP/GLC Series

■ **SIMATIC S7-400 Series (MPI via adapter)**

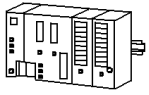
CPU	Link I/F	GP
		
CPU413-2DP	Digital's GP070-MPI-41	GP Series

■ **SIMATIC S7-300Series (Using Adapter <3964/RK512 >)**



CPU	Link I/F	Cable Diagram	GP
			
CPU313, CPU314, CPU315, CPU315-2DP	CP340 ^{*1} CP341	RS-232C (Cable Diagram 3)	GP Series

**1 When using the CP340 Link I/F an "Interpreter program" is required on the PLC. This is contained in the GP-PRO/PBIII for Windows CD-ROM 's "CP340" folder. Please see "README" file in this folder in order to install this program.*



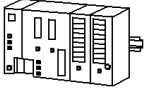

This driver cannot be used with the CPU312IFM.

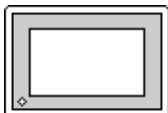
■ **SIMATIC S7-400 Series (Using Adapter <3964/RK512 >)**

CPU	Link I/F	Cable Diagram	GP
			
CPU413-2DP	CP441-2	RS-422 (Cable Diagram 4)	GP/GLC Series

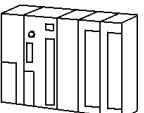
■ **SIMATIC 505 Series**

CPU	Cable Diagram	GP
		
545-1101, 545-1102, 545-1103, 545-1104, 545-1105, 545-1106, 555-1101, 555-1102, 555-1103, 555-1104, 555-1105, 555-1106	RS-232C Port 1 Connection (Cable Diagram 5)	GP Series
545-1101, 545-1102, 555-1101, 555-1102	RS-422(4-wire type) Port 2 Connection (Cable Diagram 6)	
545-1104, 545-1105, 545-1106, 555-1103, 555-1104, 555-1105, 555-1106	RS-422(4-wire type) Port 2 Connection (Cable Diagram 7)	
545-1103, 545-1104, 545-1105, 545-1106, 555-1103, 555-1104, 555-1105, 555-1106	RS-232C Port 2 Connection (Cable Diagram 8)	
545-1101, 545-1102, 555-1101, 555-1102	RS-232C Port 2 Connection (Cable Diagram 9)	

2.16.2 Cable Diagrams

The cable diagrams illustrated below and the cable diagrams recommended by Siemens may differ, however, using these cables for your PLC operations will not cause any problems.



Ground your PLC's FG terminal according to your country's applicable standard. For details, refer to the corresponding PLC manual.



- **Connect the FG line of the Shield cable to either the GP or PLC, depending on your environment. When using a Housing and Grounding the FG line, be sure to use an electrical conductor.**
- **For the RS-232C connection, use a cable length 15m or less.**
- **If a communications cable is used, it must be connected to the SG (signal ground).**

Cable Diagram 1 (RS-232C)

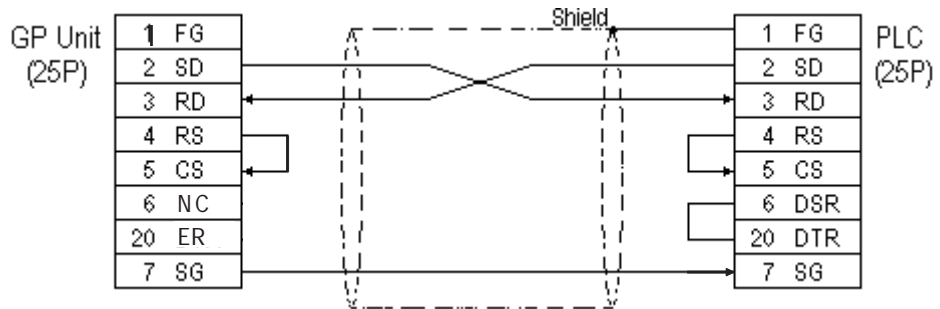

Cable Diagram 2 (RS-422)

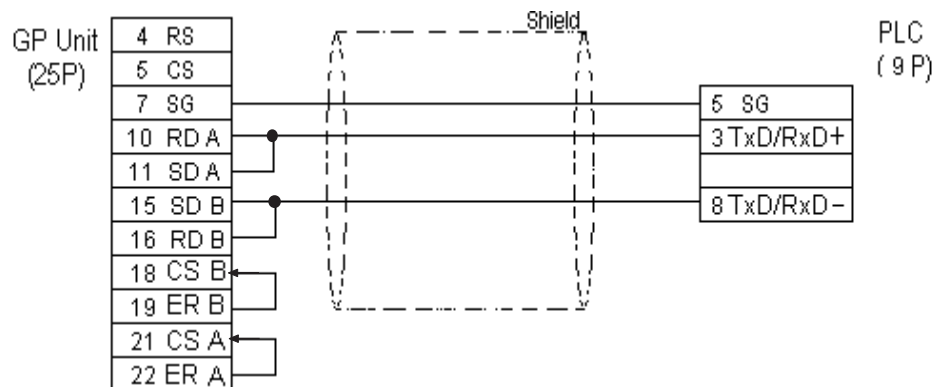

Cable Diagram 3 (RS-232C)

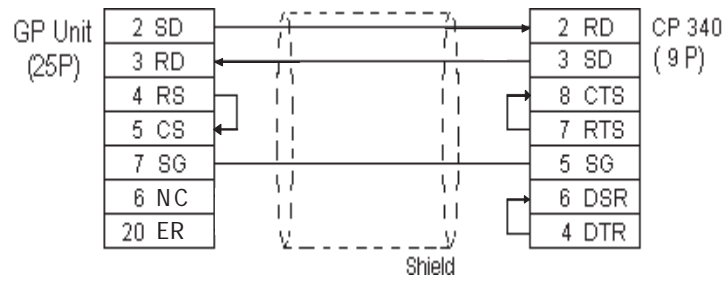

Cable Diagram 4 (RS-422)

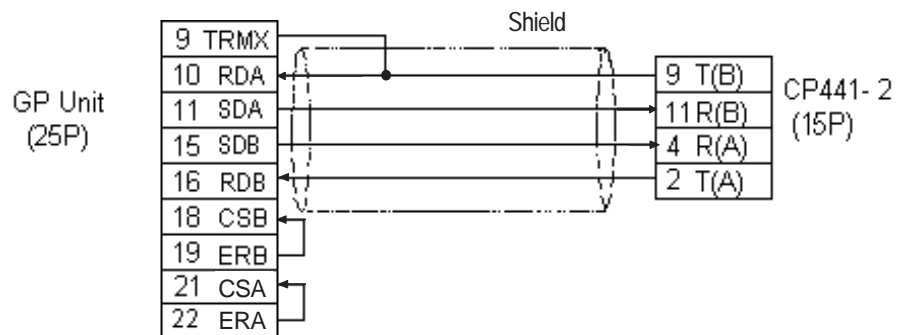

Cable Diagram 5 (RS-232C)

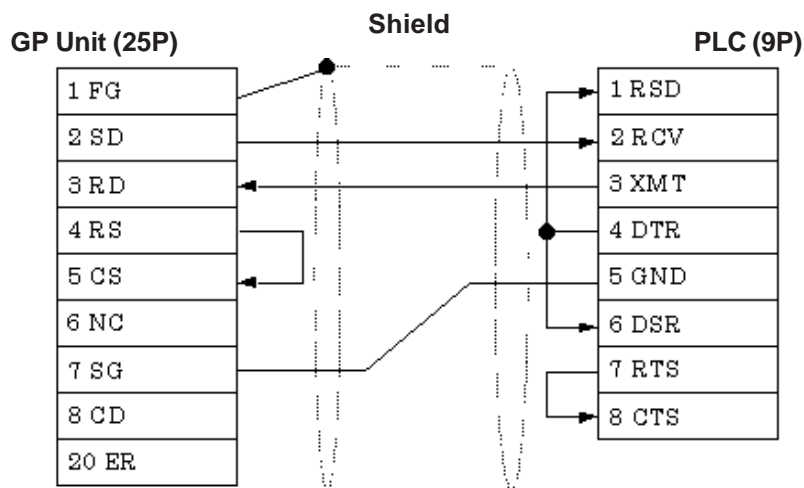

Cable Diagram 6 (RS-422)

- When using Digital's RS-422 connector terminal adapter, GP070-CN10-O

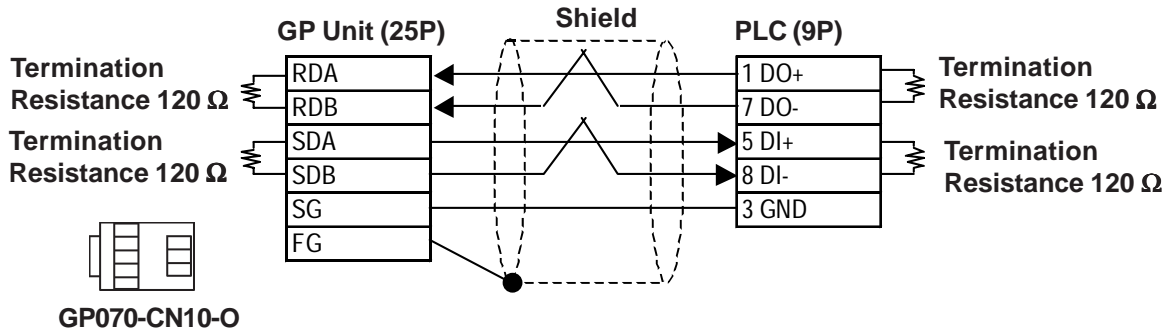

- When making your own cable connections

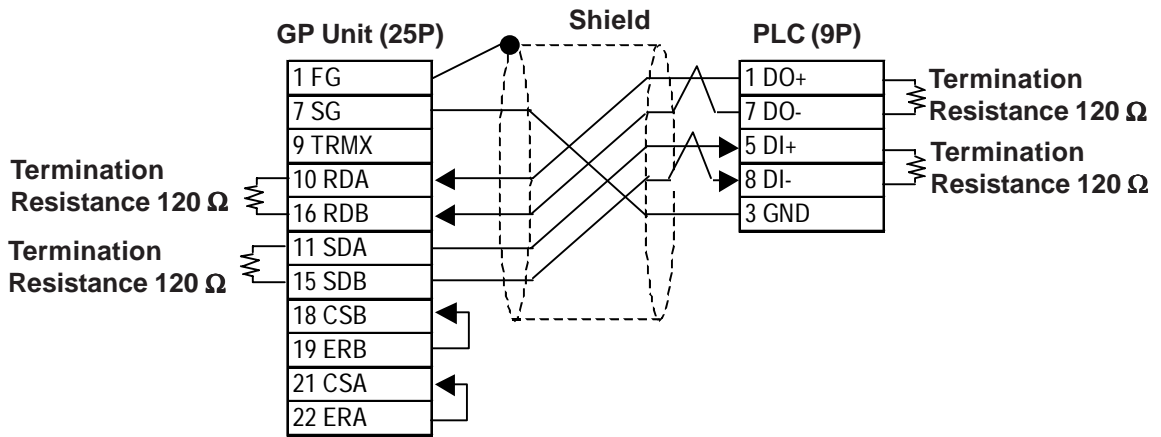

Cable Diagram 7 (RS-422)

- When using Digital's RS-422 connector terminal adapter, GP070-CN10-O

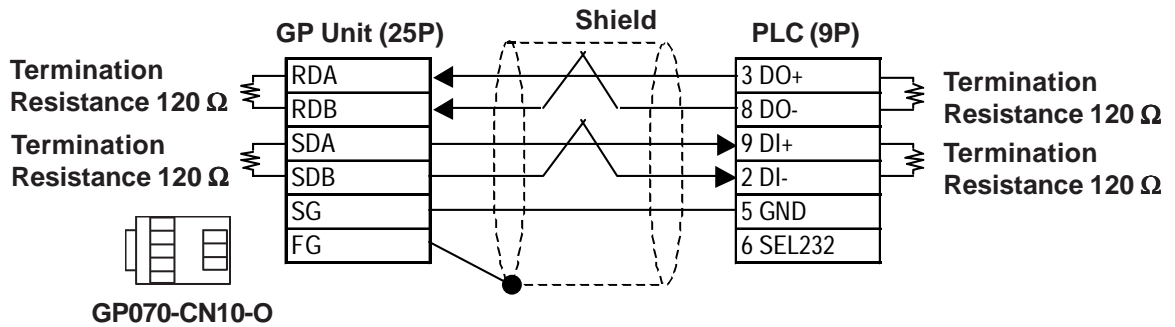

- When making your own cable connections

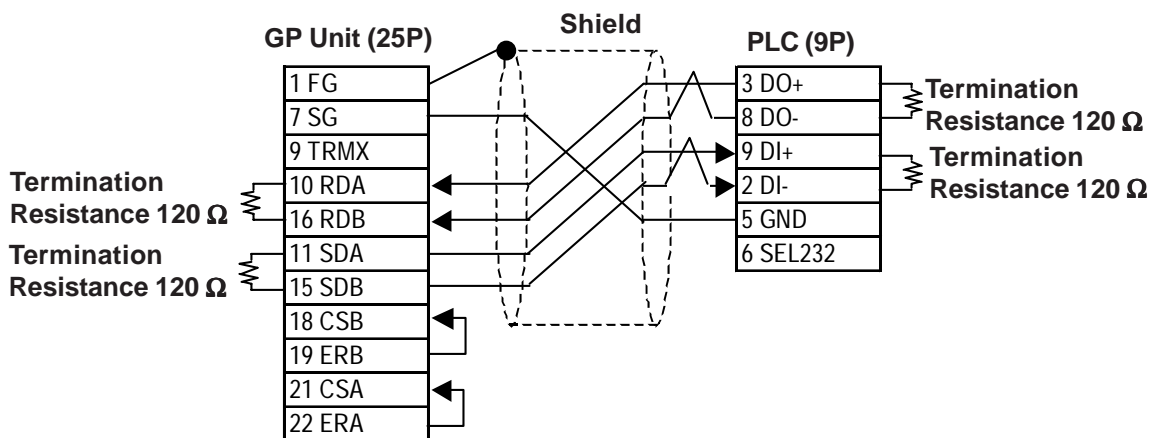

Cable Diagram 8 (RS-232C)

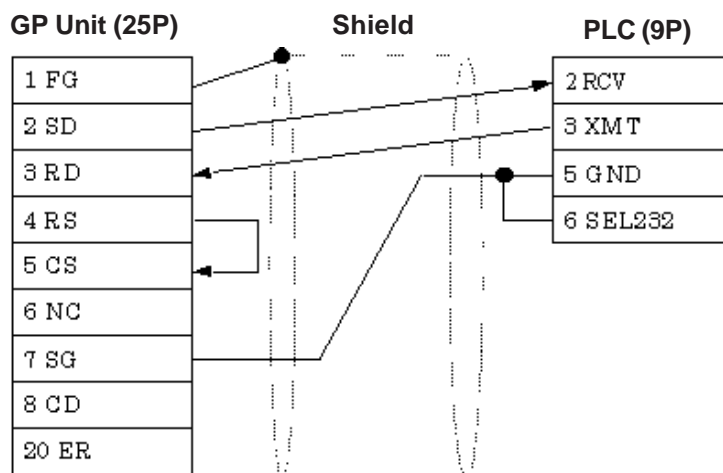

Cable Diagram 9 (RS-232C)

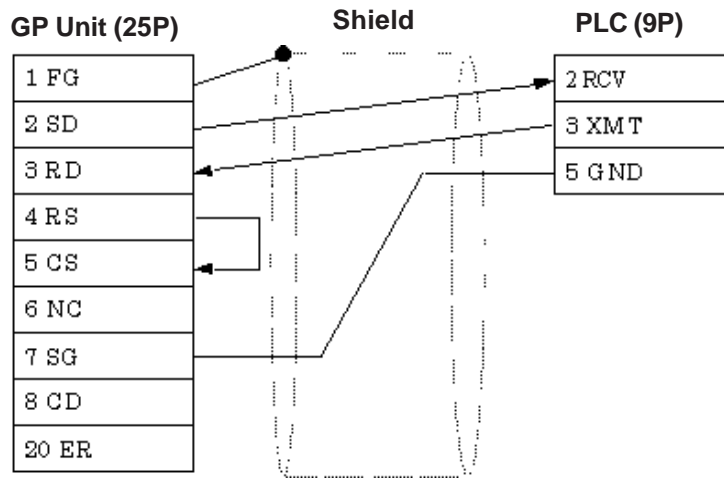

Cable Diagram 10 (RS-422 2-wire type)



- Use a cable length 50m or less for a single segment.

- When using Digital's RS-422 connector terminal adapter, GP070-CN10-O

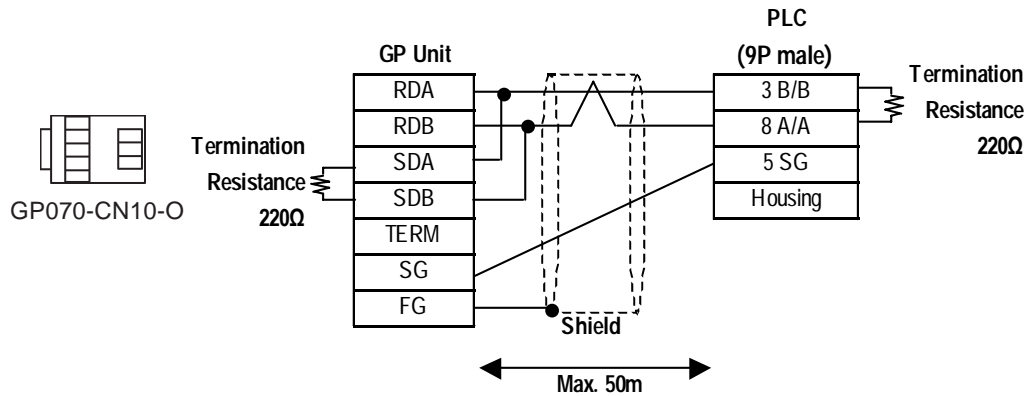

- When making your own cable connections

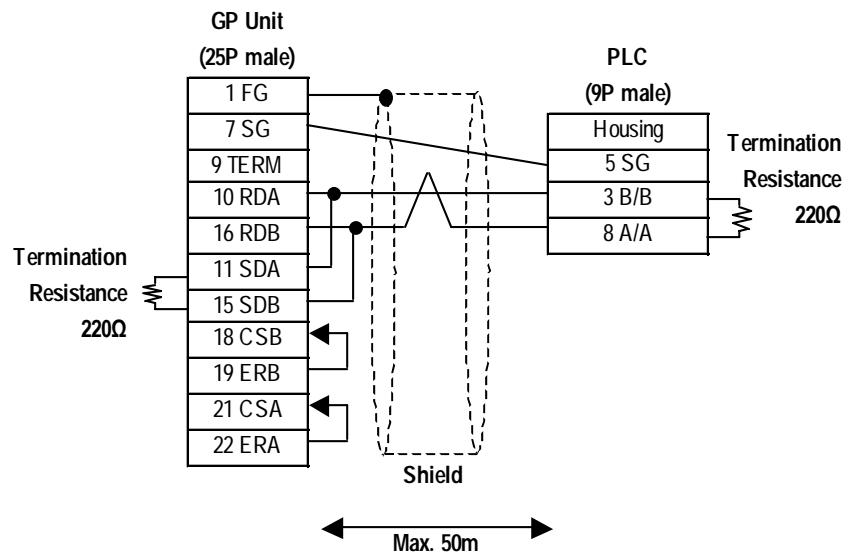

When using the following PLCs (MPI and Profibus port are the same type), the following cable diagram also can be used.

318-2(6ES7 318 2AJ00), 412-1(6ES7 412 1XF03), 412-2DP(6ES7 412 2XG00),414-2DP(6ES7 414 2XG03), 414-3DP(6ES7 414-3XJ00), 416-2DP(6ES7 416 2XK02), 416-3DP(6ES7 416-3XL00), 417-4(6ES7 417-4XL00)

- When using Digital's RS-422 connector terminal adapter, GP070-CN10-O and Siemens's Profibus Connector.

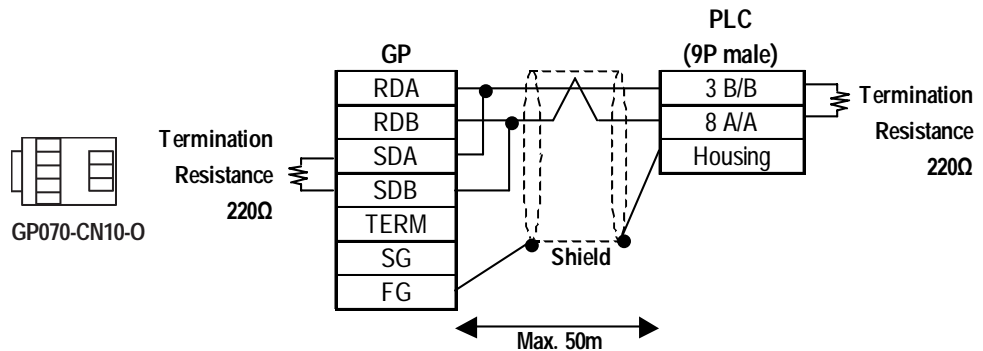

- When making your own cable connections

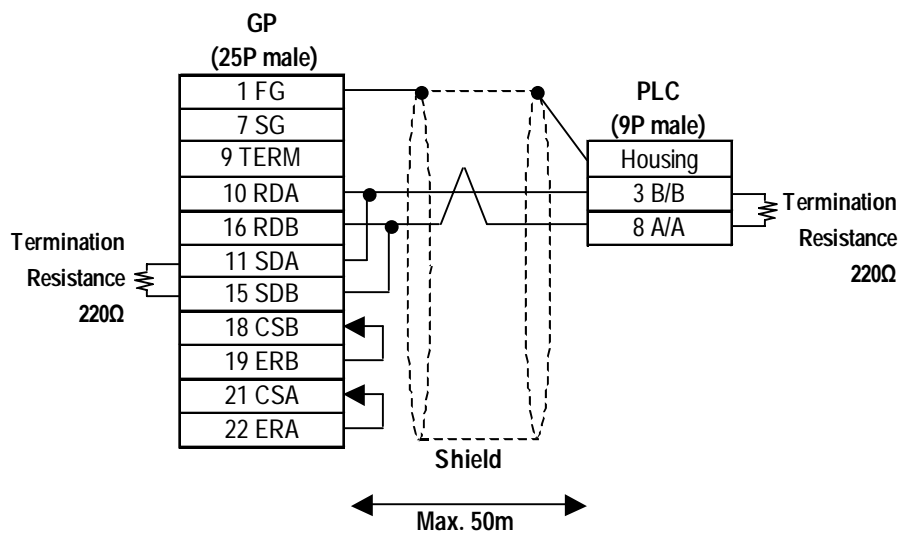

Cable Diagram 11 (RS-422 2-wire type)



- Use a cable length less than 50m for a single segment.

- When using Digital's RS-422 connector terminal adapter, GP070-CN10-O

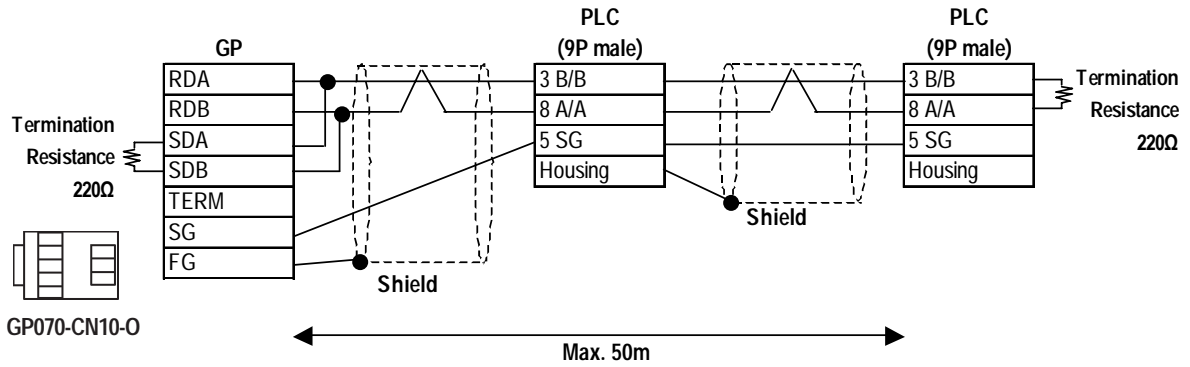

- When making your own cable connections

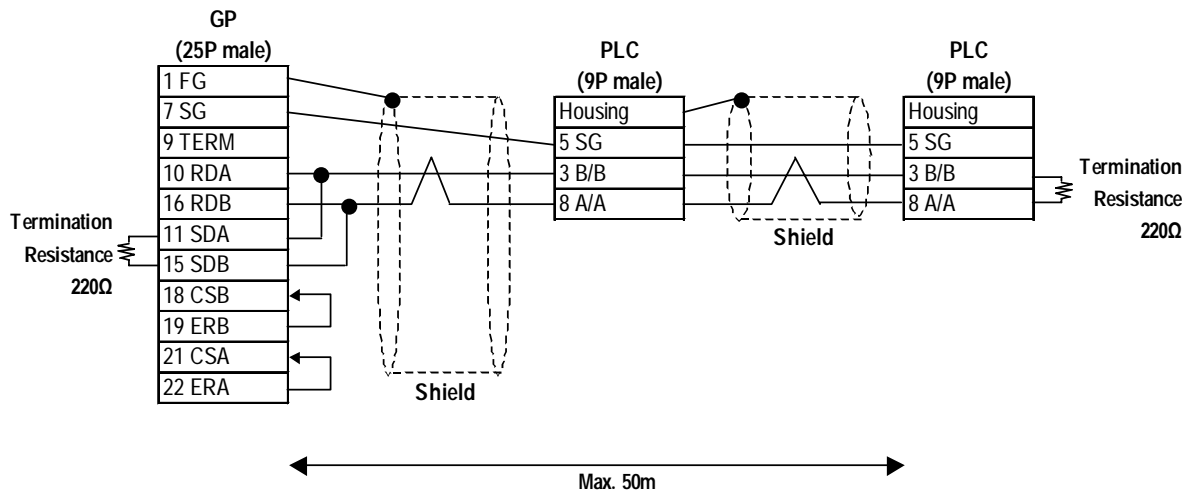

Note: When making your own cable connections, we recommend to use the terminal between the cables because the PLC side connector is Dsub 9-pin connector.

When using the following PLCs (MPI and Profibus port are the same type), the following cable diagram also can be used.

318-2(6ES7 318 2AJ00), 412-1(6ES7 412 1XF03), 412-2DP(6ES7 412 2XG00), 414-2DP(6ES7 414 2XG03), 414-3DP(6ES7 414-3XJ00), 416-2DP(6ES7 416 2XK02), 416-3DP(6ES7 416-3XL00), 417-4(6ES7 417-4XL00)

- When using Digital's RS-422 connector terminal adapter, GP070-CN10-O and Siemens's Profibus Connector.

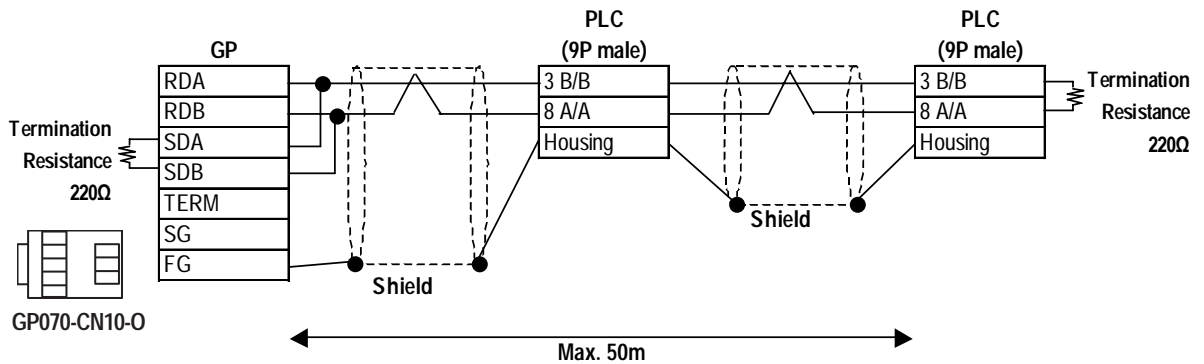

- When making your own cable connections

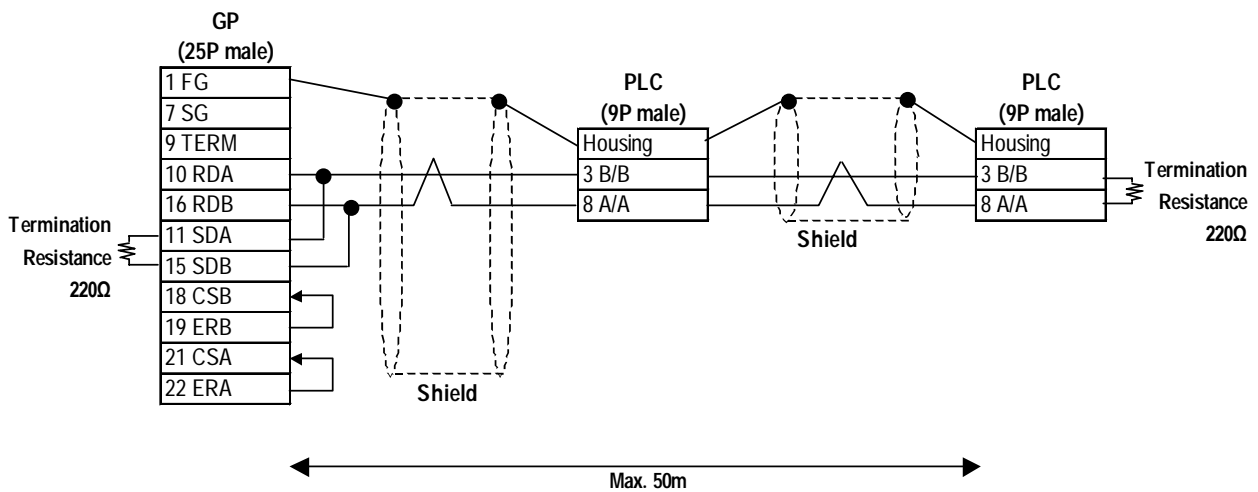

Cable Diagram 12 (RS-422 2-wire type)



- Use a cable length less than 50m for a single segment.

- When using Digital's RS-422 connector terminal adapter, GP070-CN10-O

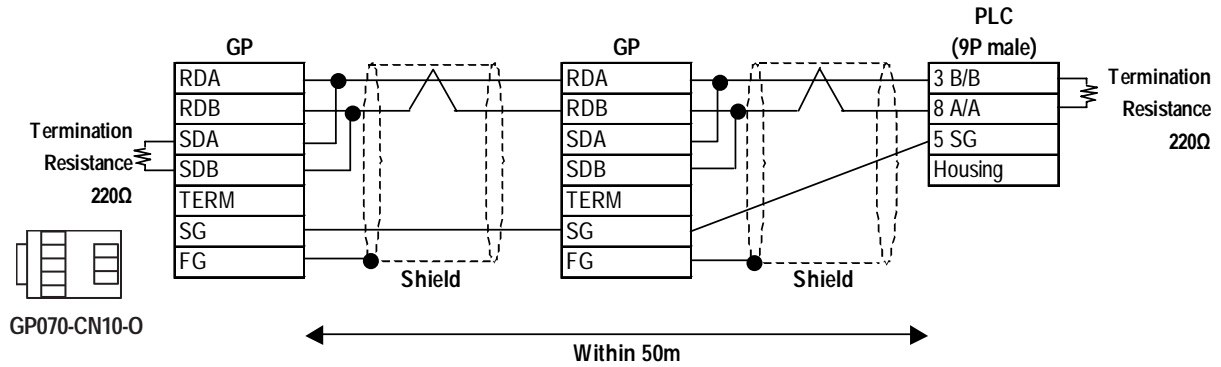

When using the following PLCs (MPI and Profibus port are the same type), the following cable diagram also can be used.

318-2(6ES7 318 2AJ00), 412-1(6ES7 412 1XF03), 412-2DP(6ES7 412 2XG00), 414-2DP(6ES7 414 2XG03), 414-3DP(6ES7 414-3XJ00), 416-2DP(6ES7 416 2XK02), 416-3DP(6ES7 416-3XL00), 417-4(6ES7 417-4XL00)

- When using Digital's RS-422 connector terminal adapter, GP070-CN10-O and Siemens's Profibus Connector.

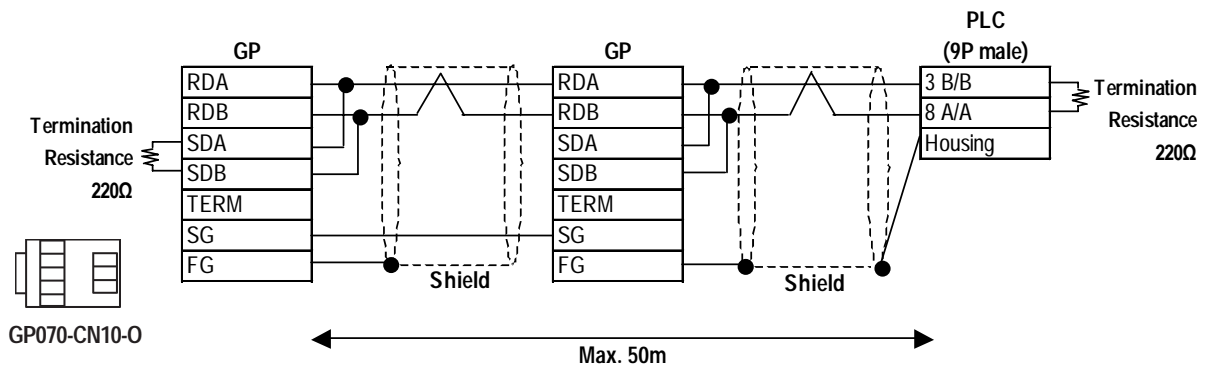



2.16.3 Supported Devices

The following tables describe the range of devices supported by the GP.

■ SIMATIC S5 Series (using Adapter)





 Setup System Area here.

Device	Bit Address	Word Address	Particulars
Data Register	---	D003000 ~ D255255	 *1*2
Extended Data Register	---	X003000 ~ X255255	 *1*2

H/L

■ SIMATIC S5 Series (CPU Direct)

 Setup System Area here.

Device	Bit Address	Word Address	Particulars
Input Relay	I0000 ~ I1277	IW000 ~ IW126	 *3
Output Relay	Q0000 ~ Q1277	QW000 ~ QW126	 *3
Internal Relay	F0000 ~ F2557	FW000 ~ FW254	 *3
Timer	---	T000 ~ T255	
Counter	---	C000 ~ C255	
Data Register	---	D002000 ~ D255255	 *1*4
Extended Data Register	---	X002000 ~ X255255	 *1*4*5

H/L

* 1 The range for the Data Register and the Extended Data Register must also be set up in the PLC. Communication will not occur with the GP when the System Area range is not setup.

* 2 The Data Register and Extended Data Register is as illustrated below.

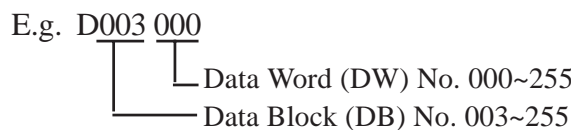

* 3 The bit device illustration for the PLC side is different.

E.g.

GP	PLC
Q0007	Q0.7

* 4 The Data Register and Extended Data Register is as illustrated below.

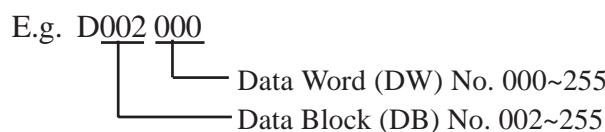





* 5 The Extended Data Register is possible only with S5 135U/155U.



Note: For information about Bit Write process differences, see the end of this section.

■ **SIMATIC S7-200 Series (PPI Connection)**



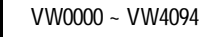

 Setup System Area here.

Device	Bit Address	Word Address	Particulars
Input	I00 ~ I77	IW0 ~ IW6	 *1
Output	Q00 ~ Q77	QW0 ~ QW6	 *1
Internal Memory	M000 ~ M317	MW00 ~ MW30	 *1
Special Memory	SM000 ~ SM857	SMW00 ~ SMW84	 *1
Timer Bit	T000 ~ T127	---	H/L
Counter Bit	C00 ~ C63	---	
Variable Memory	---	 VW0000 ~ VW4094	
Timer Word	---	TW000 ~ TW127	
Counter Word	---	CW000 ~ CW127	

*1 The bit position is the last digit entered. There is no '.' delimiter - e.g. I3.7 is equivalent to I37 in GP-PRO/PBIII.

■ **SIMATIC S7-200 Series (MPI Direct)**

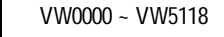
 Setup System Area here.

Device	Bit Address	Word Address	Particulars
Input	I0000.0 ~ I0015.7	IW0000 ~ IW0014	 H/L
Output	Q0000.0 ~ Q0015.7	QW0000 ~ QW0014	 H/L
Internal	M0000.0 ~ M0031.7	MW0000 ~ MW0030	 H/L
Timer	---	T0000 ~ T0255	*1
Counter	---	C0000 ~ C0255	*1
Variable Memory	---	 VW0000 ~ VW5118	 







*1 Cannot be written in. When performing data write, a Host communication Error (02:FB) will occur.  **Reference** 2.16.5 Error Codes



- **Pro-Server cannot read/write.**
- **When connecting multiple GP units, be sure to set each unit's system area top address so that it does not overlap the system area of another GP.**

■ SIMATIC S7-300/400 Series (MPI Direct/MPI via adapter)

 Setup System Area here.

Device	Bit Address	Word Address	Particulars
Input	E00000.0 ~ E00127.7	EW00000 ~ EW00126	 *1
Output	A00000.0 ~ A00127.7	AW00000 ~ AW00126	 *1
Internal Memory	M00000.0 ~ M00255.7	MW00000 ~ MW00254	 *1
Timer		T00000 ~ T00127	*2 *3 H/L
Counter		Z00000 ~ Z00063	*2 *3
Data Block		DB1W00000 ~ DB60W65532	  *3 *4
Data Block	DB1.DBX0.0 ~ DB65535.DBX65533.7	DB1.DBW0 ~ DB65535.DBW65532	 *5 *6

*1 When using a GP70 Series unit (except for GP-377 Series units), only devices of the PLC registered as #1 in the Target Node (PLC) area can be used. All other GP/GLC units can use PLC device #1 to #4, set up in the Target Node (PLC) area. For Target Node setting, refer to 2.16.4 Environment Setup.

*2. Data write cannot be performed. If data write is attempted, a Host Communication error (02:FB) will occur. **Reference** 2.16.5 Error Codes

*3. Only the PLC device registered as #1 in the Target Node (PLC) area can be used. For Target Node setting, refer to 2.16.4 Environment Setup.

*4 The addressing format for entering on GP-PRO/PB III is different from the convention used in the S7-300/400 - e.g. DB63W00020 is equivalent to DB63.DBW20.

*5 When Data Blocks other than DB61 in a 1:1 Connection or using a 1:n connection designating data blocks for multiple PLCs, use this address. However, the maximum number of data blocks is 40. GP70 Series units (except for GP-377 Series units) cannot use this devices.

*6 When using the Data Block Device, be sure to perform the settings via GP-PRO/PBIII for Windows' [GP Setup] - [Mode Settings] - [MPI Network] - [Data Block Configuration] menu.

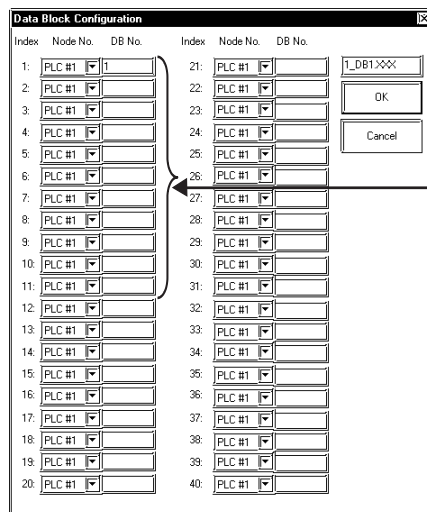

Set up (enter) the Data Block No. you want to use



- **Pro-Server read/write of devices using data blocks DB1.DBW0 to DB65535.DBW65532 is not possible. With other devices, read/write is possible only with the PLC registered as #1 in the Target Node (PLC) area. For Target Node setting, refer to 2.16.4 Environment Setup.**
- **When designating indirect addresses for E-tags and K-tags, devices using data blocks DB1.DBW0 to DB65535.DBW65532 cannot be used.**
- **When connecting multiple GP units, be sure to set each unit's system area top address so that it does not overlap the system area of another GP.**

◆ **Setting the GP-PRO/PBIII for Windows**

To set any Part or Tag on the GP-PRO/PBIII, specify the registration number of the PLC when entering the address. If not, the last entered device number is assumed. (The default value is 01).

To use a registration number, previously register that number by selecting MPI Network from the Mode Settings tab of the GP Settings window.

- **When setting an N-tag connecting to SIMATIC S7-200 Series units (MPI Direct)**

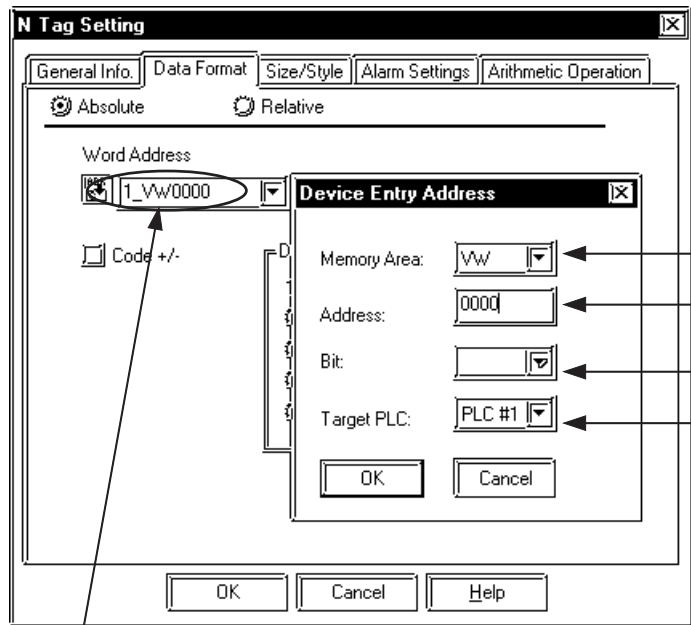

Device name
 Address
 Bit position
 Target PLC No.
 Select a PLC's registered Number #1 to #4 in the Target Node (PLC) area.

Reference
 2.16.4 Environment Setup

1 VW0000
 Device address
 PLC's Registered Number setting in the Target Node (PLC) area.

- When setting an N-tag connecting to SIMATIC S7-300/400 Series units (MPI Direct/MPI via Adapter)

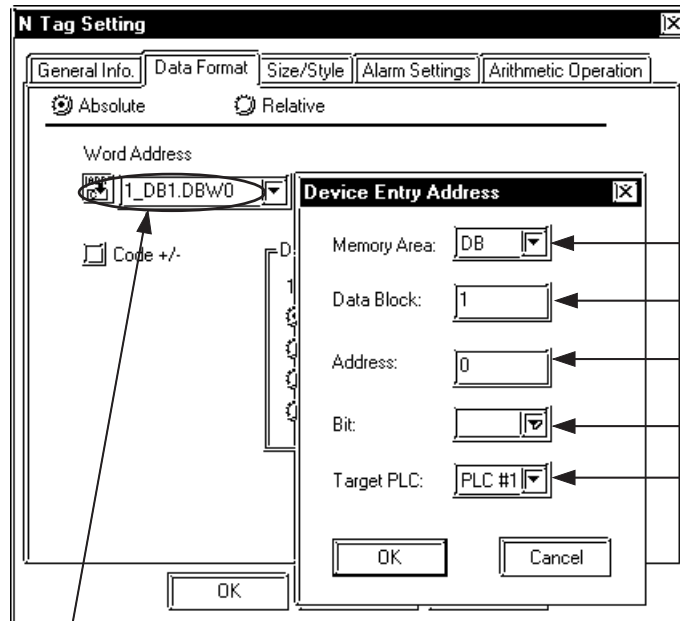

Device name
 Data Block
 Address
 Bit position
 Target PLC No. Select a PLC 's registered Number #1 to #4 in the Target Node (PLC) area.
Reference
 2.16.4 Environment Setup

1 DB1.DBW0

Device address

PLC's Registered Number setting in the Target Node (PLC) area.

■ SIMATIC S7-300/400 (via 3964/RK512)

Setup System Area here.

Device	Bit Address	Word Address	Particulars
Data Memory	DB1W000000 ~ DB60W002547	DB1W000000 ~ DB60W00254	 *1*2 H/L



It is possible to enable/disable the Block Check Character (BCC) in PLC to GP communications.

This can be performed via the GP's OFFLINE mode, or, via the GP-PRO/PBIII Editor's Mode Area's "Option" Command.

*1 Some Data Blocks are reserved for the 3964 interpreter program: DB2, DB3, DB5 & DB10.

*2 The addressing format for entering settings in GP-PRO/PB III is different from the convention used in the S7-300/400 - e.g. DB63W00020 is equivalent to DB63.DBW20.

■ SIMATIC 505 Series

Setup System Area here.

Device	Bit Address	Word Address	Particulars
Variable Memory	_____	V00001 ~ V26624	
Word Input	_____	WX00001 ~ WX08192	*1 L/H
Word Output	_____	WY00001 ~ WY08192	
Discrete Input accessed as bit	X0001 ~ X8192	_____	
Discrete Output accessed as bit	Y0001 ~ Y8192	_____	
Control Relay Accessed as bit	CR00001 ~ CR32768	_____	
Loop Gain	_____	LKC0001 ~ LKC0064	*2
Loop Reset	_____	LTI0001 ~ LTI0064	*2
Loop Rate	_____	LTD0001 ~ LTD0064	*2
Loop Alarm High Limit	_____	LHA0001 ~ LHA0064	*2
Loop Low Alarm Limit	_____	LLA0001 ~ LLA0064	*2
Loop Process Variable	_____	LPV0001 ~ LPV0064	*2
Loop PV High Limit	_____	LPVH0001 ~ LPVH0064	*2
Loop PV Low Limit	_____	LPVL0001 ~ LPVL0064	*2
Loop Orange Deviation Limit	_____	LODA0001 ~ LODA0064	*2
Loop Yellow Deviation Alarm Limit	_____	LYDA0001 ~ LYDA0064	*2
Loop Sample Rate	_____	LTS0001 ~ LTS0064	*2
Loop Setpoint	_____	LSP0001 ~ LSP0064	*2
Loop Output	_____	LMN0001 ~ LMN0064	*2
Loop Error	_____	LERR0001 ~ LEERR0064	*1 *2
Loop Bias	_____	LMX0001 ~ LMX0064	*2
Loop Alarm High-High Limit	_____	LHHA0001 ~ LHHA0064	*2
Loop Low-Low Alarm Unit	_____	LLLA0001 ~ LLLA0064	*2
Loop Rate of Change Alarm Limit	_____	LRCA0001 ~ LRCA0064	*2
Loop Setpoint High Point	_____	LSPH0001 ~ LSPH0064	*2

(Continued on next page)

■ SIMATIC 505 Series

Device	Bit Address	Word Address	Particulars		
Loop Setpoint Low Limit	_____	LSPL0001 ~ LSPL0064	*2		
Loop Alarm Deadband	_____	LADB0001 ~ LADB0064	*2		
Loop V-flags	_____	LVF0001 ~ LVF0064		L/H	
Most Significant Word of Loop C-flags	_____	LCFH0001 ~ LCFH0064			
Least Significant Word of Loop C-flags	_____	LCFL0001 ~ LCFL0064			
Analog Alarm/Alarm Acknowledge Flags	_____	AADB0001 ~ AADB0128	*2		
Most Significant Word of Analog Alarm C-flags	_____	ACFH0001 ~ ACFH0128		L/H	
Least Significant Word of Analog Alarm C-flags	_____	ACFL0001 ~ ACFL0128			
Analog Alarm Error	_____	AERR0001 ~ AERR0128	*1*2		
Analog Alarm High Alarm Limit	_____	AHA0001 ~ AHA0128	*2		
Analog Alarm High-High Alarm Limit	_____	AHHA0001 ~ AHHA0128	*2		
Analog Alarm Low Alarm Limit	_____	ALA0001 ~ ALA0128	*2		
Analog Alarm Low-Low Alarm Limit	_____	ALLA0001 ~ ALLA0128	*2		
Analog Alarm Loop Orange Deviation Alarm Limit	_____	AODA0001 ~ AODA0128	*2		
Analog Alarm Process Variable	_____	APV0001 ~ APV0128	*2		
Analog Alarm Rate of Change Alarm Limit	_____	ARCA0001 ~ ARCA0128	*2		
Analog Alarm Setpoint	_____	ASP0001 ~ ASP0128	*2		
Analog Alarm SP High Limit	_____	ASPH0001 ~ ASPH0128	*2		
Analog Alarm SP Low Limit	_____	ASPL0001 ~ ASPL0128	*2		
Analog Alarm Sample Rate	_____	ATS0001 ~ ATS0128	*2		
Analog Alarm Yellow Deviation Alarm Limit	_____	AYDA0001 ~ AYDA0128	*2		
Timer/Counter Preset	_____	TCP0001 ~ TCP1024	*3		L/H
Timer/Counter Current	_____	TCC0001 ~ TCC1024	*3		
Drum Counter Preset	_____	DCP0101 ~ DCP6416	*3*4		
Drum Step Preset	_____	DSP0001 ~ DSP0064	*3*5*6		
Drum Step Current	_____	DSC0001 ~ DSC0064	*3*5*6		
Status Word	_____	STW0001 ~ STW0222	*1		
Drum Count Current	_____	DCC0001 ~ DCC0064	*1		

(Continued on next page)

(From previous page)

- *1 *The GP cannot write data to this device. Use it only for reading.*
- *2 *This device uses Float. When this type of device is used, only the E-tag and K-tag's "32 bit Float" setting can be used.*
- *3 *32 bit reading / writing, or reading / writing a K-tag's text string cannot be performed.*
- *4 *Address entry method:*
 - Enter 1.01 as "101"*
 - Enter 1.02 as "102"*
 - Enter 1.03 as "103"*
 - ...*
 - Enter 1.16 as "116"*
 - Enter 2.01 as "201"*
 - Enter 2.02 as "202"*
 - ...*
 - Enter 64.15 as "6415"*
 - Enter 64.16 as "6416"*
- *5 *Entry range is from 0 to 15 (dec.)*
- *6 *+1 is added to all data input from the GP to the PLC. -1 is added to all data output from the PLC to the GP.*

<i>GP</i>	<i>→</i>	<i>PLC</i>	
<i>1</i>	<i>→</i>	<i>2</i>	<i>("1" entered from the GP is changed to "2" in the PLC.)</i>
<i>5</i>	<i>←</i>	<i>6</i>	<i>("6" sent from the PLC to the GP will become "5".)</i>

2.16.4 Environment Setup

The following lists Digital's recommended PLC and GP communication settings.

■ SIMATIC S5 Series (using Link I/F)

GP Setup		Link I/F Setup	
Baud Rate	19200 bps	Baud Rate	19200 bps
Data Length	8 bits	Data Bit	8 bits
Stop Bit	1 bit	Stop Bit	1 bit
Parity Bit	Even	Parity Bit	Even
Data Flow Control	ER Control		---
Communication Format (RS-232C)	RS-232C		---
Communication Format (RS-422)	4-wire type		---
Unit No.	0 (fixed)		---

■ SIMATIC S5 Series (CPU Direct)

GP Setup		PC Link Unit Setup
Baud Rate	9600 bps (fixed)	---
Data Length	8 bits (fixed)	---
Stop Bit	1 bit (fixed)	---
Parity Bit	Even (fixed)	---
Data Flow Control	ER Control (fixed)	---
Communication Format	RS-232C (fixed)	---
Unit No.	0 (fixed)	---

System Data Area Setup

- SYSTEM DATA AREA START DB—used to setup the Data Register's Data Block (DB) Number.
- SYSTEM DATA AREA START DW—used to setup the Data Register's Data Word (DW) Number.

▼ Reference X "2.16.3 Supported Devices"

If Link I/F is used, the system's number is indicated before the DB (Data Block) on the INITIALIZE area's [SETUP OPERATION SURROUNDINGS] screen. Changing this number, however, is not necessary since this data will be used only for future expansion.



- The method of writing bits will differ depending on the GP series.

<GP-*30 series>

When the bit write operation (other than *Reverse*) is performed, the corresponding word address will set the bits to 0 (except the designated bits).

<Except GP-*30 series>

When the bit write operation is performed, the GP reads the PLC's corresponding word address and turns a bit ON, then send back to PLC. Do not write to the word address from the ladder program in the middle of this operation.

- When running a GP-*30 Series ladder program, be aware of the above points.

■ SIMATIC S7-200 Series (PPI Connection)

GP Setup		PC Link Unit Setup
Baud Rate	9600 bps	---
Data Bit	8 bits	---
Parity Bit	Even	---
Stop Bit	1 bit	---
Data Flow Control	ER Control	---
Communication Format	RS-422 2-wire type	---
GP No.	1	---
PLC No.	2	2

■ SIMATIC S7-200 Series (MPI Direct)

GP Setup			PLC Setup		
Baud Rate ^{*1}	19200 bps		Baud Rate	19200 bps	
Data Length	8 bits (fixed)		_____	_____	
Stop Bit	1 bit (fixed)		_____	_____	
Parity Bit	Even (fixed)		_____	_____	
Data Flow Control	ER (fixed)		_____	_____	
Communication Format	RS-422 2-Wire type (fixed)		_____	_____	
Highest Node No. ^{*2*3}	31		Highest Address ^{*3}	31	
GP is Only Master ^{*4}	ON		_____	_____	
Enable Node Control Area ^{*9}	OFF		_____	_____	
Local Node (GP) ^{*5}	1		_____	_____	
Target Node (PLC)	No. of PLCs ^{*7}	1	_____	_____	
	Node Number ^{*8}	#1	2	MPI Address ^{*6}	2
		#2	Depending on the PLC's MPI Address	MPI Address ^{*6}	0 to 126
		#3	Depending on the PLC's MPI Address	MPI Address ^{*6}	0 to 126
		#4	Depending on the PLC's MPI Address	MPI Address ^{*6}	0 to 126

- *1 *Baud Rate can be 9600bps, 19200bps or 187500bps depending on the PLC unit's Baud rate. However, certain GP units cannot use the 187500bps speed. **▼Reference▲** 2.16.1 System Structure SIMATIC S7-200 Series (MPI Direct)*
If the 187500bps speed is used with incompatible GP Series units, a Host Communication error (02:F2) will occur.
▼Reference▲ 2.16.5 Error Codes
- *2 *15/31/63/126 can be selected. Be sure this setting is the same as the PLC unit's Highest Address setting.*
- *3 *15/31/63/126 can be selected. On a single network, choose the value that is higher than the maximum value of the GP's Local Node or the PLC's MPI Address. For example, if the maximum value is 16, then select 31. Specify the smallest practical value for the maximum node address. This will shorten the time required for initializing the network.*
- *4 *When MPI master does not exist on a single network, a GP can be master. When GP is master, set to ON.*
- *5 *Set the GP's unit number. Setting range is from 0 to 126, and the maximum number of GP units that can be connected is 3. Be sure this number is not used as a PLC's Node No.*
- *6 *Set the PLC unit's node number. Setting range is from 0 to 126, and the maximum number of PLCs that can be connected is 4. Be sure this number is not used as a GP and another PLC unit's Node No.*
- *7 *Select the number of PLCs to use for data communication.*
- *8 *Register the PLC's MPI Address. This setting can only be entered using the GP-PRO/PBIII software. The GP unit's OFFLINE mode cannot be used.*
- *9 *When the checkbox is selected, the Node Control Area is enabled. Setting Range: LS20 to LS8910. The Node Control Register and the Node Status Register cannot use the same address. If they do, an input error will occur.*

*For setting details, **▼Reference▲** ■ S7-200/S7-300/S7-400 Series Node Control Area.*
- *10 *Selecting (check mark) this checkbox enables the Time Master settings. When the Time Master is enabled, the Time Interval set via the PLC overwrites the Master PLC's GP time data. Use the PLC's ladder software to perform master PLC settings. Select the [H/W Configuration] -> CPU menu's [Diagnostics Properties] -> Diagnostics/Clock feature. For details, refer to your PLC's Operation Manual.*
(Continued on next page.)



Note:

The following diagram is the Siemens S7-200 Series MPI Network setting window. This window is displayed by clicking on the [MPI Network] button in the [GP System Setup]-[Mode Settings] tab. The numbers in the diagram refer to the footnote numbers shown previously.

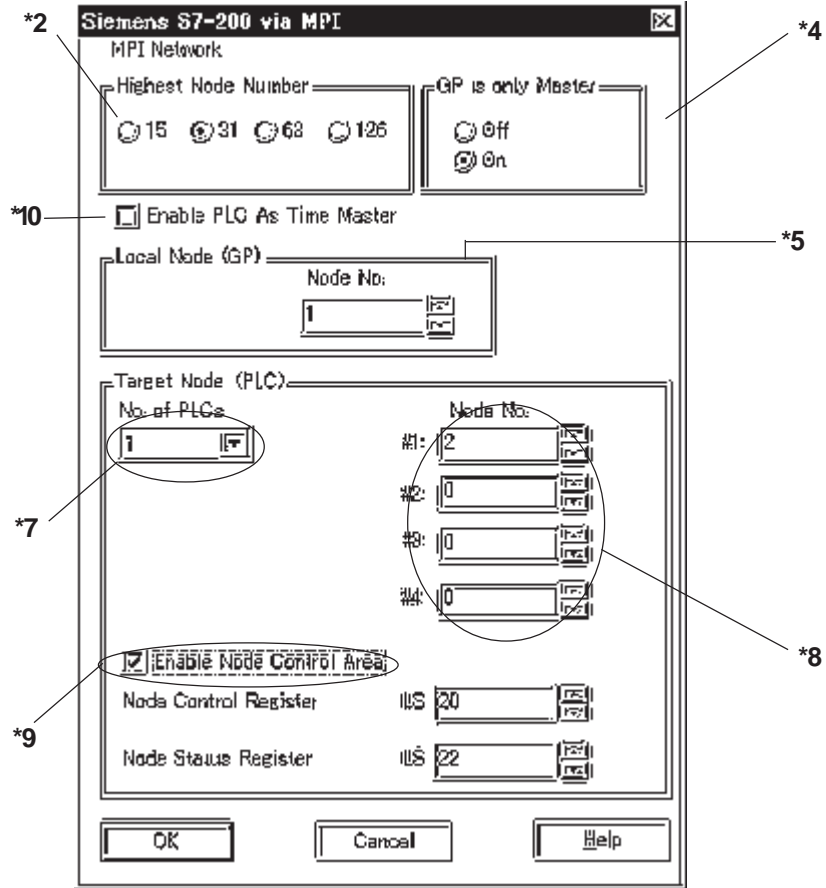

<SIMATIC S7-200 Series MPI Network Setting Window>



Important

Be sure to perform MPI Network settings prior to performing MPI communication.

■ SIMATIC S7-300/400 Series (MPI Direct / MPI via adapter)

GP Setup		PLC Setup		
Baud Rate ^{*1}	19200 bps	Baud Rate ^{*9}	_____	
Data Length	8 bits (fixed)	_____	_____	
Stop Bit	1 bit (fixed)	_____	_____	
Parity Bit (when using adapter)	Odd (fixed)	_____	_____	
Parity Bit (when using direct connection)	Even (fixed)	_____	_____	
Data flow Control	ER (fixed)	_____	_____	
Communication Format (MPI Direct Connection)	RS-422 (2-wire)	_____	_____	
Communication Format (MPI via Adapter)	RS-232C	_____	_____	
Highest Node No. ^{*2 *3}	31	Highest Address ^{*3}	31	
Connection Method ^{*4}	via Adapter (fixed)	_____	_____	
Enable NodeControl Area ^{*10}	OFF	_____	_____	
Local Node (GP) ^{*5}	1	_____	_____	
Target Node (PLC)	No. of PLCs ^{*7}	1	_____	
	Node Num ^{*8}	#1	2	MPI Address ^{*6} 2
		#2	Depending on the PLC MPI Address	MPI Address ^{*6} 0 to 126
		#3	Depending on the PLC MPI Address	MPI Address ^{*6} 0 to 126
		#4	Depending on the PLC MPI Address	MPI Address ^{*6} 0 to 126

*1 Baud Rate speed can be 19200bps or 187500bps depending on the PLC's unit baud rate. However, certain GP units cannot use the 187500bps speed.

▼ **Reference** 2.16.1 System Structure ◆ Connectable GP/GLC units for SIMATIC S7-200/300/400 Series (MPI Direct).

If 187500bps is used with an incompatible GP Series unit, a Host Communication error (02:F2) will occur. ▼ **Reference** 2.16.5 Error Codes

When using an MPI via Adapter connection, Baud Rate speed can be 19200bps, 38400bps or 115200bps. However, when using another adapter, Baud Rate speed can only be 19200bps.

*2 15/31/63/126 can be selected. Be sure this setting is the same as the PLC unit's Highest Address setting.

*3 15/31/63/126 can be selected. On a single network, choose the value that is higher than the maximum value of the GP's Local Node or the PLC's MPI Address. For example, if the maximum value is 16, then select 31. Specify the smallest practical value for the maximum node address. This will shorten the time required for initializing the network.

*4 Set the Connection Method.

*5 Set the GP's unit number. Setting range is from 0 to 126, and the maximum number of GP units that can be connected is 3. Be sure this number is not used as a PLC's Node No.

- *6 Set the PLC unit's node number. Setting range is from 0 to 126, and the maximum number of PLCs that can be connected is 4. Be sure this number is not used as a GP and another PLC unit's Node No.
- *7 Select the number of PLCs to use for data communication. Setting range is from 1 to 4.
- *8 Register the PLC's MPI Address. Depending on the No. of PLC setting, from #2 to #4 can be set. This setting can only be entered using the GP-PRO/PBIII software. The GP unit's OFFLINE mode cannot be used.
- *9 The Baud Rate Setting is not required when using MPI via Adapter connection.
- *10 When the checkbox is selected, the Node Control Area is enabled.
Setting Range: LS20 to LS8910. The Node Control Register and the Node Status Register cannot use the same address. If they do, an input error will occur.
For setting details, **Reference** ■ S7-200/S7-300/S7-400 Series Node Control Area.
- *11 Selecting (check mark) this checkbox enables the Time Master settings. (The Time Master feature can only be used when the Connection method is Direct). When the Time Master is enabled, the Time Interval set via the PLC overwrites the Master PLC's GP time data. Use the PLC's ladder software to perform master PLC settings. Select the [H/W Configuration] -> CPU menu's [Diagnostics Properties] -> Diagnostics/Clock feature to perform the settings. For details, refer to your PLC's Operation Manual.



Note:

The following diagram is Siemens S7-300/400 Series MPI Network setting window. This window is displayed by clicking on the [MPI Network] button in the [GP System Setup]-[Mode Settings] tab. The number in the diagram refers to the footnote number as shown above.

The screenshot shows the 'Siemens S7-300/400 via MPI' window. Callouts are as follows:

- *2: Points to the 'Highest Node Number' radio buttons (15, 31, 63, 126).
- *4: Points to the 'Connection Method' radio buttons (via MPI Adaptor, Direct).
- *5: Points to the 'Data Block Configuration' button.
- *7: Points to the 'No. of PLCs' dropdown menu (set to 1).
- *8: Points to the 'Node Num.' input fields for #1, #2, #3, and #4.
- *10: Points to the 'Enable Node Control Area' checkbox (checked).
- *11: Points to the 'Enable PLC As Time Master' checkbox (unchecked).

Additional text annotations:

- 'Selecting this checkbox *11 enables the GP to receive PLC time data' points to the *11 checkbox.
- 'Clicking this button displays the "Data Block Configuration" screen where you can enter data block settings. For details, **Reference** 2.16.3 Supported Devices' points to the *5 button.

<SIMATIC S7-300/400 Series MPI Network Setting Window>

■ S7-200/S7-300/S7-400 Series Node Control Area

When multiple nodes (PLCs) are connected using an MPI direct connection, the Node Control feature allows you to control the GP unit's access of multiple nodes (PLCs).

<System Design>

In the following example 4 PLCs are connected to a single GP. If the PLC units all operate normally, data transfer is carried out smoothly.

However, if one or more of the PLC units develops an error and is taken out of the network, any read/write tags used on the GP unit's screen will create a communication error. The resulting connection retries will then slow the performance of the network.

When all PLC units are operating normally:

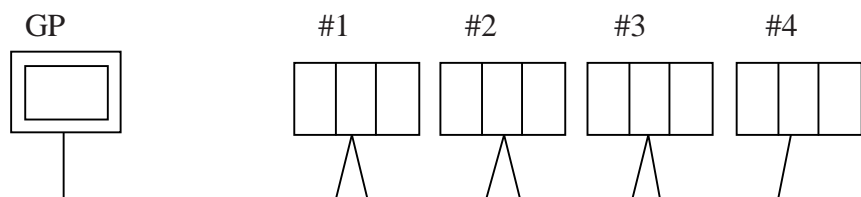

Here readout processing is performed in order - #1 -> #2 -> #3 -> #4 -> #1 -> #2 , etc.

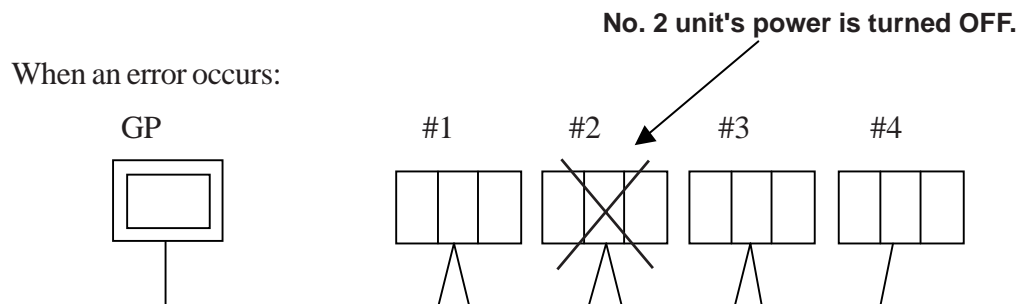

When unit #2's power is turned OFF, a communication error will occur. After the error occurs, the GP unit's communication retries will begin.

The processing pattern will then become #1 -> error processing -> #3 -> #4 -> #1 -> error processing, etc.

The error processing is continually trying to read out data, which will delay the overall speed by 1 cycle.

Using the Node Control feature, the Node Control Register's bit is used to control communication while the PLC is online.

When the above type of system is used, D-Script can be used to detect errors and turn the Node Control Area's bit OFF to stop communication with unit #2.

This, in turn, creates a readout pattern of #1 -> #3 -> #4 -> #1 -> #3, and so on that skips Node #2 completely and prevents the overall cycle time from slowing.

◆ **Node Control Area Settings**

Control of each Node is possible using the following LS bit operation allocated to the Node Control Area.

▼ **Reference** ▲ For the setup procedure, see pg. 2-16-29, *9

Also, in the Node Status Area the communication error's status can be checked.

- Node Control Area Bit: 0: No communication 1: Performing communication
- Node Status Area Bit: 0: No error 1: Error occurred

Node Control Area

Each bit is allocated to each Node. (Position 4 bit and onwards are reserved.)

Ex. As shown below, Nodes #1, #2 and #4 are communicating normally with the GP. Node #3 is not communicating.

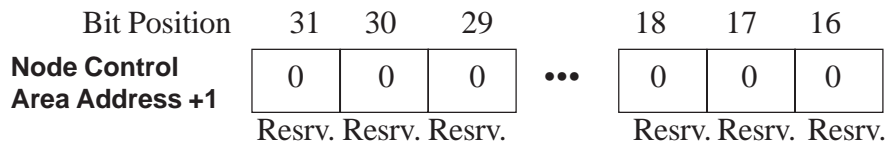
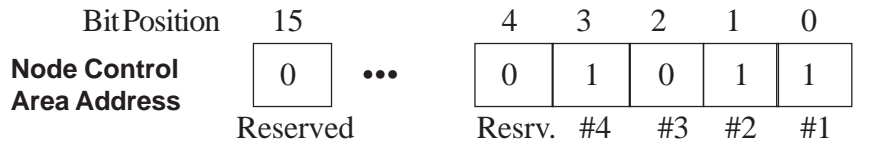

Node Status Area

Ex. As shown below, Nodes #1 and #4 developed a communication error.

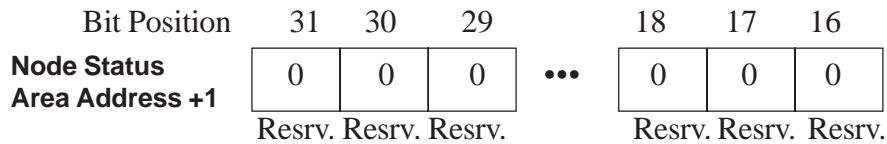
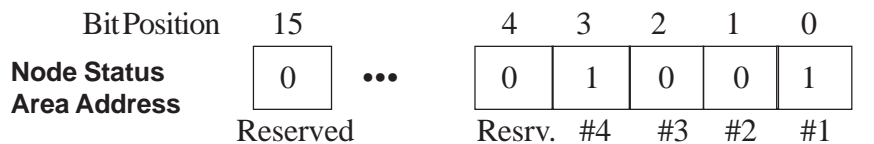

■ SIMATIC S7-300/400 (Using Adapter< 3964/RK512>)

GP Setup		PC Link Unit Setup
Communication-format	RS-232C	---
Baud Rate	19200 bps	---
Data Bit	8 bits	---
Parity Bit	Even	---
Stop Bit	1 bit	---
Data Flow Control	ER Control	---



Note:

It is possible to enable/disable the Block Check Character (BCC) in communications between the PLC and the GP. This configuration can be performed via the Editor's [Mode] -> [Option] menu.

■ SIMATIC 505

GP Setup		PLC Settings	
Baud Rate	19200 bps	Baud Rate	19200 bps
Data Length	7 bits	Data Length	7bits (fixed)
Stop Bit	1 bit	Stop Bit	1bit (fixed)
Parity Bit	Odd	Parity Bit	Odd (fixed)
Data Flow Control	ER Control	_____	_____
Communication Format (RS-232C)	RS-232C	Communication Format (RS-232C)	Turn on the Dip Switch 1 on CPU.
Communication Format (RS-422)	RS-422 (4-wire type)	Communication Format (RS-422)	Turn on the Dip Switch 1 on CPU.

2.16.5 Error Codes

<MPI Error Codes>

An error code specific to the MPI is displayed in the lower left corner of the GP screen like "Host communication error (02:**:##)." ** stands for the error code specific to the MPI. ## stands for the Node No. of the PLC on which the error has occurred. Error Codes F0, F2 and F3 is not displayed the Node No. of the PLC

■ Error Codes

Error Code	Description
F0	The cable is not connected. The PLC's power is OFF.
F1	Unable to locate target node.
F2	GP does not support 187500bps data transfer speed.
F3	A Timeout has occurred on the MPI network.
F4	Failed to connect to Target Node.
FB	Designated device or address does not exist, or other similar problem.