

15-inch Unit Cover Set (CA4-CVR15-01) Installation Guide

Thank you for purchasing Pro-face's 15-inch Unit Cover Set.

These covers are attached to the PS-3701A /PS-3711A unit (hereafter referred to as the "PS-A") and FP-3700T/FP-3710T unit(hereafter referred to as the "FP").

All product names used in this document are the trademarks of their respective manufactures.

Pro-face : Digital Electronics Corporation (in Japan and other countries)



The 15-inch Unit Cover Set is required when using the 15-inch Unit Stand.



Note: For 15-inch Unit Stand and 15-inch Unit Power Supply installation procedures, please refer to the "15-inch Unit Stand 15-inch Unit Power Supply Installation Guide".

Package Contents

■ 15-inch Unit Cover Set (3 covers)

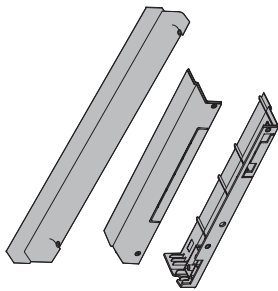

■ Cover Attachment Screws (6)



■ Installation Guide (this guide) : 1

■ Angle Plate (1)

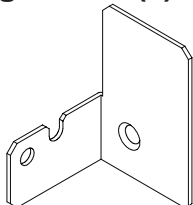

■ Angle Plate Attachment Screw (1)

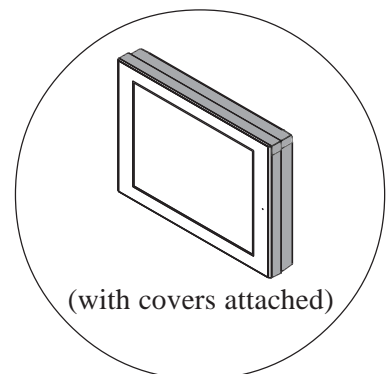

(with covers attached)

This unit has been carefully packed, with special attention to quality. However, should you find anything damaged or missing, please contact your local distributor immediately.

1 Installation



CAUTION

During installation be sure not to pinch your hand or fingers between the PS-A/FP unit and any of the 15-inch Unit Covers.

- 1) Remove the PS-A/FP unit's Moisture Resistant Gasket and two (2) rear face screws (See *1 below) and one (1) rear face screw (See *2 below). Be sure to save these screws.
- 2) Attach the Angle Plate to the right-side cover and secure them to the PS-A/FP unit's *2 part using an attachment screw removed in Step 1. (Required torque: 0.5 to 0.6 N•m.)
- 3) Then, secure the right-side cover to the PS-A/FP unit's *1 parts using two(2) attachment screws removed in Step 1. (Required torque: 0.5 to 0.6 N•m.)
Next, secure the left-side cover to the PS-A/FP unit using two(2) attachment screws. (Required torque: 0.5 to 0.6 N•m.)

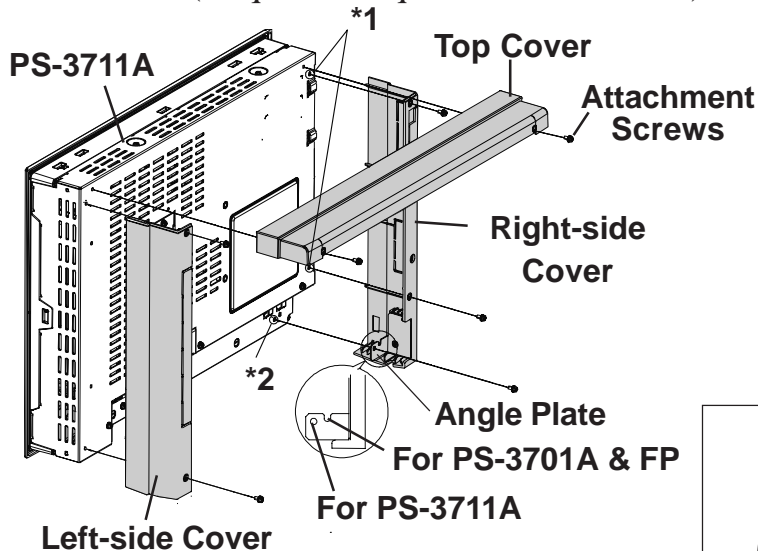

Remove here when using
CD-ROM Drive Unit PSS-
CD01 for PS-3701A.

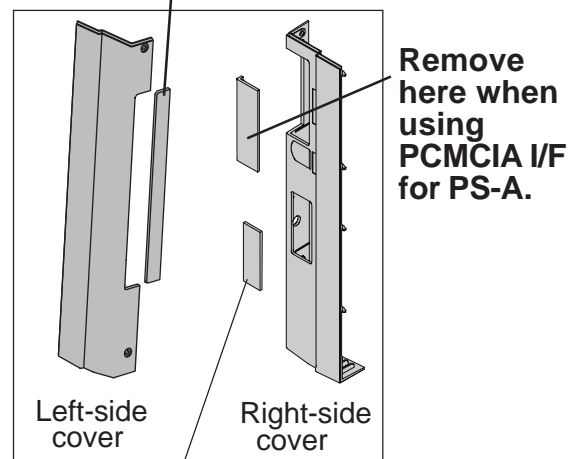

- 4) Finally, use the two (2) attachment screws to secure the top cover to the PS-A/FP. (Required torque: 0.5 to 0.6 N•m.)



Remove the portion of the cover using a nipper as shown the right figure depending on which interface of the PS-A/FP you use.

Remove here when using
LAN or PS/2 Keyboard
I/F for PS-3711A.

Note

Be aware that the Digital Electronics Corporation shall not be held liable for any real or estimated damages or losses, or third party claims resulting from the use of this product.

Digital Electronics Corporation
8-2-52 Nanko Higashi, Suminoe-ku,
Osaka 559-0031, Japan
URL: <http://www.pro-face.com/>