



Pro-face solutions in a time of new normal



What Will Manufacturing's New Normal Be?

Pro-face solutions in a time of new normal

Paradigm shift

Get ready for the future with Pro-face

As an HMI specialist, this is our mission in a time of new normal

Make sure the human interfaces to the machines and system are as safe as possible. But also to leverage our innovative technology to answer the new challenges the entire world population is facing.

HMI Centric Concept

HMI is a window to people and machines that lets everyone from operators to managers access the information. they need in the format they desire from any device or network. HMI Centric Solutions make the best of the human workforce with the digital technology.

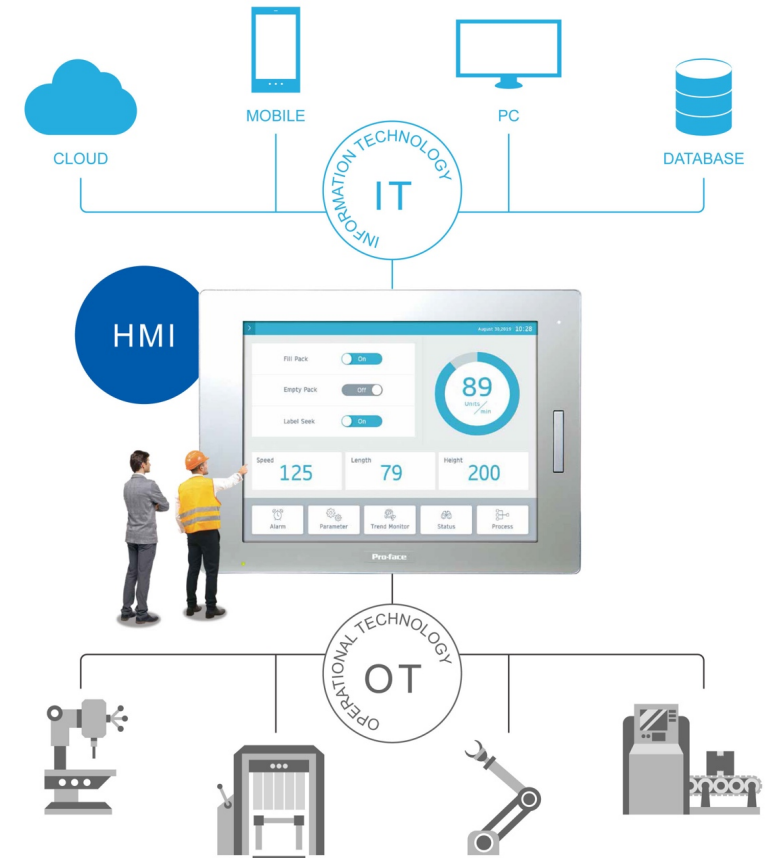

4 main challenges for which we are helping

Hygiene



- HMI Screen cleaning recommendations
- Rear-mount HMI to keep high sanitary level

Contact Reduction



- Touch operations with gloves
- System to avoid common equipment
- Less or Zero touch operation by ID card reader

Social distancing



- A full set of HMI solutions on personal device
- Stay home while doing efficient maintenance tasks

Case Study



- For Health care industry

1 Hygiene



We have very detailed test reports about resistance by chemical elements.
Possibility to clean up with alcohol with demonstrated resistance.

FAQ: FA406458

Can alcohol be used to clean (disinfect, clean) HMI products such as programmable displays and industrial computers?

It's possible.

Our programmable displays, displays of industrial computers, etc. The display can be disinfected using a commercially available alcohol (such as ethanol) disinfectant. Do not spray the disinfectant directly on the display, but soak it on a soft cloth and wipe it slowly.
* It can be used in the same way even if the environmental protection cover is used.

However, please note the following points.
Please pay attention to the precautions of the disinfectant used and the usage environment.
Do not use thinner, benzene, organic solvents and strong acidic substances. To protect the touch sheet, do not rub the edge part strongly.

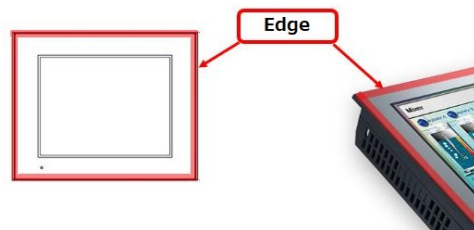

▶ FAQ

(Search by FA406458)

Flat mounting has the benefit of **preventing the accumulation of dust and mold**, and even allows the display to be used in **medical equipment**, food manufacturing equipment and other devices used in **environments where hygiene is important**.

Maintain Hygiene of Display Area (Flat mount only)

Creates a flat, SEAMLESS display area to prevent accumulation of mold and dust, and to maintain a hygienic environment. Protective structure performance equivalent to IP65F can be expected*.

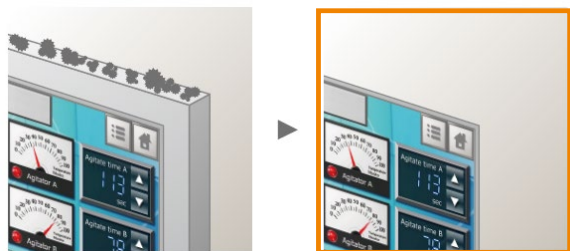

* By affixing an overlay (optional) to a console made from a specified material or a surface-treated console. For details, please refer to the Hardware manual.

Choose from Mounting Patterns

Screen and bracket position selectable

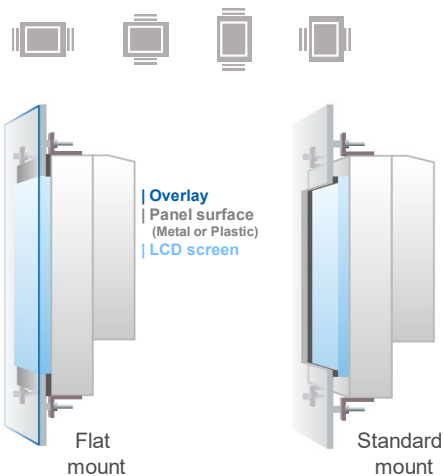

Contact Reduction



Touch operation is possible even when wearing gloves

Operation with gloves to reduce contact each other

Product	Touch Panel Type	Groves	Touch Pens
GP4000 Series (Including GP4000H, GP4000M, GP4100 series) SP5000 Series (Except 15"W and 19"W) SP5000X Series LT4000M Series PS5000 Series 15.0" and 12.1"	Resistive Touch Panel	OK	OK (Recommended Touch Pen: CA7-TPPEN/ALL-01 (5 pieces per set))
SP5000 15"W and 19"W PS5000 (Except 15.0" & 12.1")	Capacitive Touch Panel	Industry use groves: OK *1	Touch Pens for Smart Phone/Tablet

Note:

- If you operate with something that has a pointed top like a ballpoint pen, the touch panel might get damaged and might not run. Be careful.
- Touch Pen: CA7-TPPEN/ALL-01 cannot be used for models using capacitive touch panels.



***1** Following materials/Thickness of gloves were tested and worked

Polyethylene	PVC	Cotton	Leather	Rubber
				
0.03~1mm	0.3~1.8mm	1.5mm	1.7mm	1.1mm

Be sure to check the operation before starting to use. Depend on materials, mixed spinning or thickness, you might not able to operate.





Use your own HMI Avoid contacting common HMI each others

Mobile operations by Box HMI + QR code + Tablet

How does it work

- 1 Create QR (IP address, server Name).
- 2 Read the QR with a tablet.
- 3 Connect to the HMI Box specified by QR.
- 4 Monitor and operate the HMI via tablet.

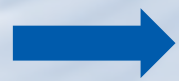

192.168.1.10

Products List

Pro-face			3rd Party		
01	Solution for data collection without display module		04	QR code reader Apps	
02	HMI Screen editor & Logic Programming Software		05	Tablet	
03	See equipment information on a tablet or smart phone.		06	Wi-Fi access point	
plus					
Go to Web			Go to Web		

*1: V4.09.100 or later *2: V1.50.00 or later



► For more details



Reduce touch to type-in ID and Password by using ID card (NFC) reader

Enhance Security by ID card

How does it work

- 1 Reuse sample project file (Extended Script and screen template) to communicate with the NFC card.
- 2 Configure user management (security).
- 3 Register ID card to the HMI.



Login / Logout



Login / Logout



Login / Logout

Track who did what, and when



► For more details

Social Distancing



A full set of HMI solutions on personal device

Keep your distance with the Machine.
Monitor and operate equipment information / on-site screen on several types of thin client.

Mobile Access to SCADA

Monitor and operate **BLUE Open Studio** screen with high level of security

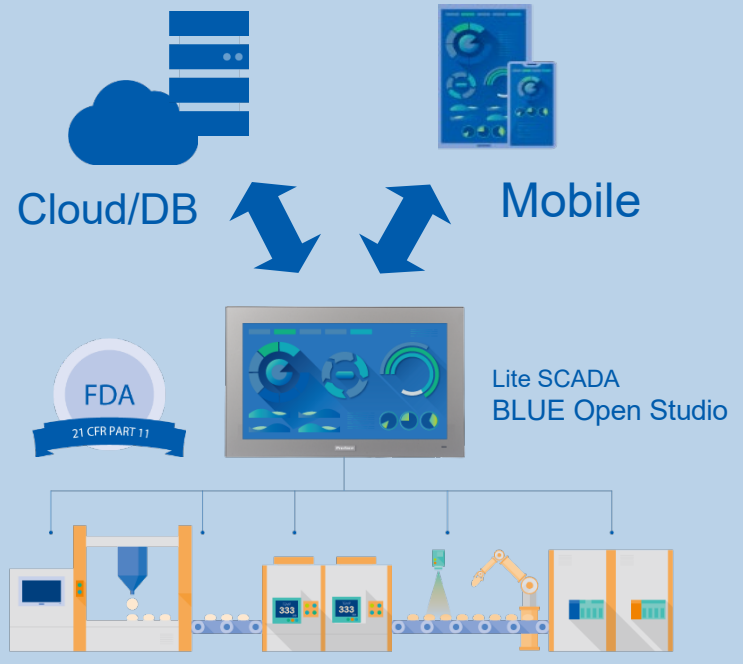

▶ For more details

Mobile Access to HMI or PC

Carry around HMI with Pro-face RemoteHMI

Pro-face RemoteHMI



Allows you to monitor and operate HMI screen made by GP-Pro EX

Remote monitoring Windows application by Pro-face RemoteHMI Server

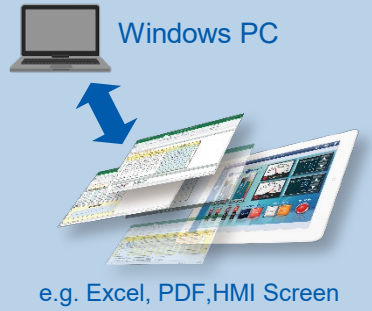

Pro-face Remote HMI Server is a Windows application to connect any PC or IPC with our Pro-face Remote HMI application and operate any kind of software via the application.

▶ For more details

Secure Remote Access

Proface Connect provides a secure way to program or monitor machines remotely

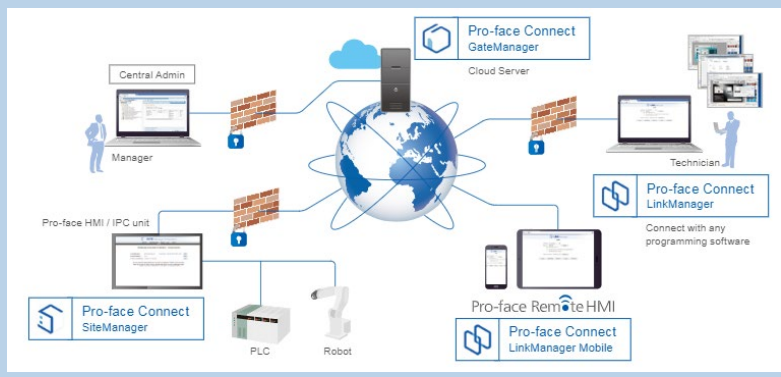

Conforms with industry level standards for security. Able to build a secure network.

- User access based on x.509 Cert.
- AES data encryption
- ISA99 and IEC 62443

▶ For more details



Stay home while doing efficient maintenance tasks

Simple & Secure Remote Service

How does it work

- 1 End User or Field Services turn on "Personal hotspot" of his smartphone
- 2 WiFi router finds the hotspot & connect.
- 3 Machine Builder access the HMI or controllers connected to the HMI.

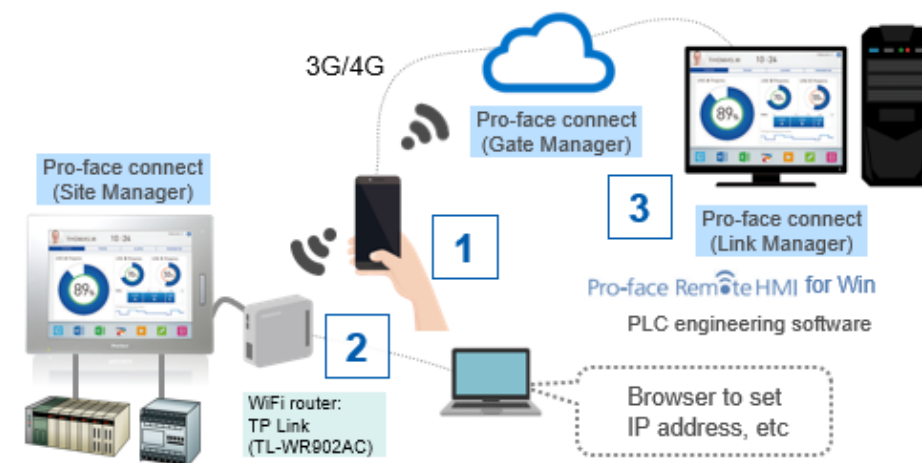
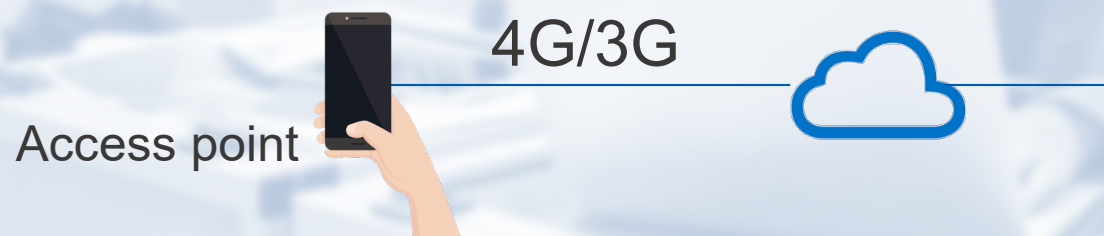

► For more details

4 Case Study



Our technology are helping health care industry

Ventilator

Reliable compact HMI for medical equipment

Medical professionals can control and monitor pressure, volume, respiratory time etc, remotely. The challenge was to have ventilators reliable, affordable and deployable around the world.

Our HMI was chosen as one of reliable components for the machine.

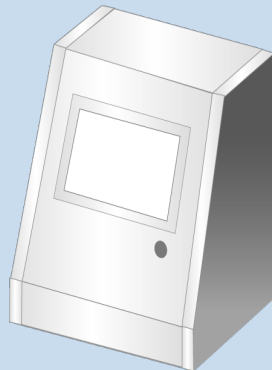

Hospital

AR system with our reliable IPC

Installed AR system (AOA+IPC) for an electric power control system in hospital. Our AR system allows to monitor/operate various status of devices without opening control panels.

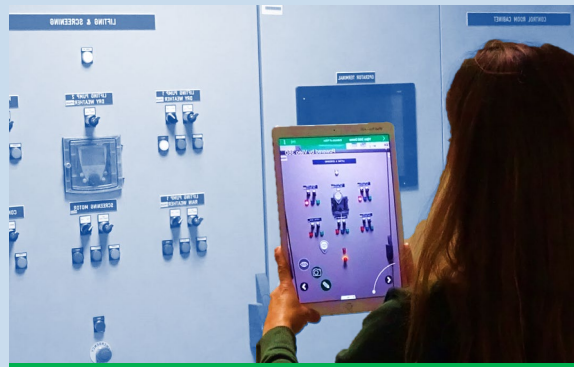

EcoStruxure Augmented Operator Advisor (AOA)

Facemask Machine

Quick engineering with our basic HMI

By using our basic HMI and screen editing software, Developed high-performance Mask machine for only 3days.

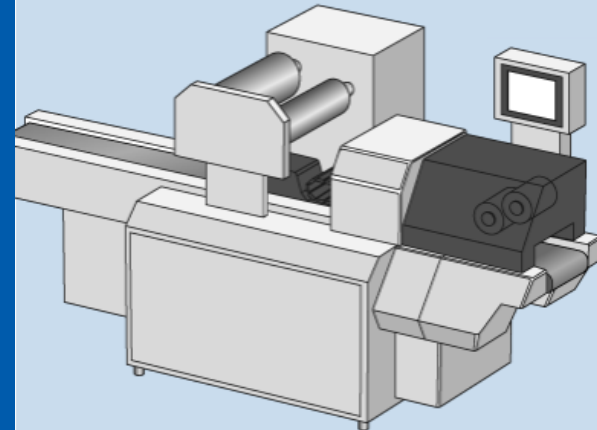

Pharmaceutical Traceability system

IPC and Line management system compliant FDA

Our Lite SCADA, BLUE Open Studio allows you to take advantage of built-in functionality to create FDA 21 CFR part 11 compliant projects with traceability and e-signatures.

Lite SCADA
BLUE Open Studio

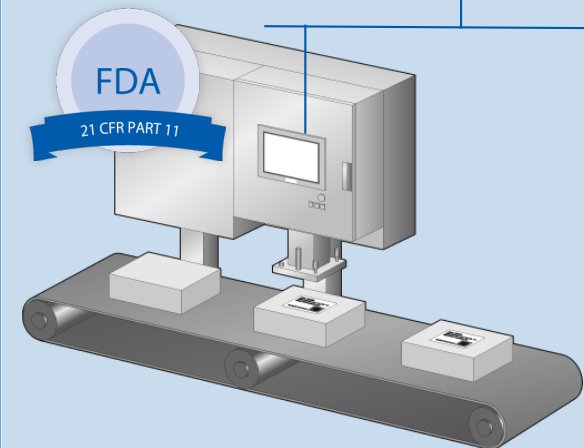



HMI Centric

“HMI Centric” makes the best of the human workforce with the digital technology.