



# HMI Monitor Protocol Driver

1	System Configuration.....	3
2	External Device Selection .....	8
3	Communication Settings .....	9
4	Setup Items .....	27
5	Cable Diagrams .....	32
6	Supported Device.....	49
7	Device Code and Address Code.....	51
8	Error Messages .....	52

## Introduction

This manual describes how to connect the Display and the External Device (target PLC).

In this manual, the connection procedure is described in the sections identified below.

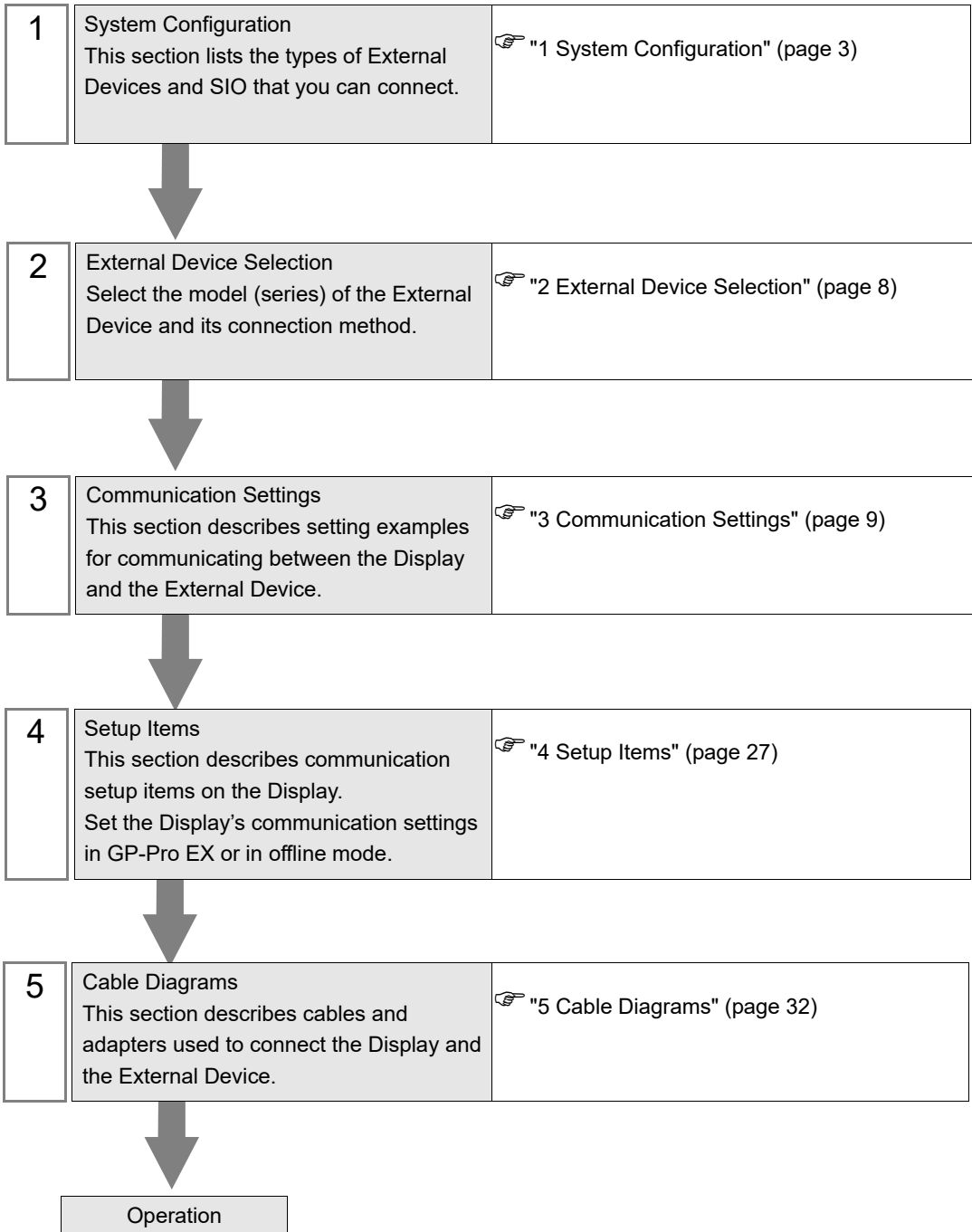

# 1 System Configuration

The following table lists system configurations for connecting Shenzhen Inovance External Devices and the Display.

Series	CPU	Link I/F	SIO Type	Setting Example	Cable Diagram
H1U-XP	H1U-0806MR-XP H1U-0806MT-XP H1U-1208MR-XP H1U-1208MT-XP	CPU (COM0)	RS-232C	Setting Example 1 (page 9)	Cable Diagram 1 (page 32)
	H1U-1410MR-XP H1U-1410MT-XP H1U-1614MR-XP H1U-1614MT-XP	CPU (COM0)	RS422/485 (2wire)	Setting Example 2 (page 11)	Cable Diagram 2 (page 34)
	H1U-1614MTD-XP H1U-2416MR-XP H1U-2416MT-XP	CPU (COM0)	RS422/485 (4wire)	Setting Example 3 (page 13)	Cable Diagram 3 (page 40)
	H1U-2820MR-XP H1U-2820MT-XP H1U-3624MR-XP H1U-3624MRD-XP	CPU (COM1)	RS422/485 (2wire)	Setting Example 4 (page 15)	Cable Diagram 4 (page 43)
	H1U-3624MT-XP H1U-3624MTD-XP	H1U-232-BD	RS-232C	Setting Example 5 (page 17)	Cable Diagram 1 (page 32)
H2U-XP	H2U-1010MR-XP H2U-1010MT-XP	CPU (COM0)	RS-232C	Setting Example 1 (page 9)	Cable Diagram 1 (page 32)
	H2U-1616MR-XP H2U-1616MT-XP H2U-2416MR-XP H2U-2416MT-XP	CPU (COM0)	RS422/485 (2wire)	Setting Example 2 (page 11)	Cable Diagram 2 (page 34)
	H2U-2416MTQ-F01 H2U-3624MR-XP H2U-3624MT-XP	CPU (COM0)	RS422/485 (4wire)	Setting Example 3 (page 13)	Cable Diagram 3 (page 40)
	H2U-3232MR-XP H2U-3232MT-XP H2U-3232MTQ H2U-3232MTP	CPU (COM1/COM2)	RS422/485 (2wire)	Setting Example 4 (page 15)	Cable Diagram 4 (page 43)
	H2U-4040MR-XP H2U-4040MT-XP H2U-6464MR-XP H2U-6464MT-XP	H2U-232-BD	RS-232C	Setting Example 5 (page 17)	Cable Diagram 1 (page 32)
	H2U-4040MR-8AB H2U-1616MTS H2U-8A91G-XP	H2U-422-BD	RS422/485 (2wire)	Setting Example 4 (page 15)	Cable Diagram 2 (page 34)
		H2U-485IF-BD	RS422/485 (2wire)	Setting Example 4 (page 15)	Cable Diagram 4 (page 43)
	H2U-8A91G-XP	CPU (COM3)	RS422/485 (2wire)	Setting Example 4 (page 15)	Cable Diagram 4 (page 43)

Series	CPU	Link I/F	SIO Type	Setting Example	Cable Diagram
H3U-XP	H3U-1616MR-XP H3U-1616MT-XP H3U-3232MR H3U-3232MT H3U0808PMRTA	CPU (COM0)	RS-232C	Setting Example 6 (page 19)	Cable Diagram 1 (page 32)
		CPU (COM0)	RS422/485 (2wire)	Setting Example 7 (page 21)	Cable Diagram 2 (page 34)
		CPU (COM0)	RS422/485 (4wire)	Setting Example 8 (page 23)	Cable Diagram 3 (page 40)
		CPU (COM1)	RS422/485 (2wire)	Setting Example 9 (page 25)	Cable Diagram 4 (page 43)

## ■ Connection Configuration

- 1:1 Connection



## ■ IPC COM Port

When connecting IPC with an External Device, the COM port used depends on the series and SIO type. Please refer to the IPC manual for details.

### Usable port

Series	Usable Port		
	RS-232C	RS-422/485(4 wire)	RS-422/485(2 wire)
PS-2000B	COM1 <sup>*1</sup> , COM2, COM3 <sup>*1</sup> , COM4	-	-
PS-3450A, PS-3451A, PS3000-BA, PS3001-BD	COM1, COM2 <sup>*1*2</sup>	COM2 <sup>*1*2</sup>	COM2 <sup>*1*2</sup>
PS-3650A (T41 model), PS-3651A (T41 model)	COM1 <sup>*1</sup>	-	-
PS-3650A (T42 model), PS-3651A (T42 model)	COM1 <sup>*1*2</sup> , COM2	COM1 <sup>*1*2</sup>	COM1 <sup>*1*2</sup>
PS-3700A (Pentium®4-M), PS-3710A	COM1 <sup>*1</sup> , COM2 <sup>*1</sup> , COM3 <sup>*2</sup> , COM4	COM3 <sup>*2</sup>	COM3 <sup>*2</sup>
PS-3711A	COM1 <sup>*1</sup> , COM2 <sup>*2</sup>	COM2 <sup>*2</sup>	COM2 <sup>*2</sup>
PS4000 <sup>*3</sup>	COM1, COM2	-	-
PL3000	COM1 <sup>*1*2</sup> , COM2 <sup>*1</sup> , COM3, COM4	COM1 <sup>*1*2</sup>	COM1 <sup>*1*2</sup>
PE-4000B Atom N270	COM1, COM2	-	-
PE-4000B Atom N2600	COM1, COM2	COM3 <sup>*4</sup> , COM4 <sup>*4</sup> , COM5 <sup>*4</sup> , COM6 <sup>*4</sup>	COM3 <sup>*4</sup> , COM4 <sup>*4</sup> , COM5 <sup>*4</sup> , COM6 <sup>*4</sup>
PS5000 (Slim Panel Type Core i3 Model) <sup>*5*6</sup>	COM1, COM2 <sup>*4</sup>	COM2 <sup>*4</sup>	COM2 <sup>*4</sup>
PS5000 (Slim Panel Type Atom Model) <sup>*5*6</sup>	COM1, COM2 <sup>*7</sup>	COM2 <sup>*7</sup>	COM2 <sup>*7</sup>
PS5000 (Enclosed Panel Type) <sup>*8</sup>	COM1	-	-
PS5000 (Modular Type PFXPU/PFXPP) <sup>*5*6</sup> PS5000 (Modular Type PFXPL2B5-6)	COM1 <sup>*7</sup>	COM1 <sup>*7</sup>	COM1 <sup>*7</sup>
PS5000 (Modular Type PFXPL2B1-4)	COM1, COM2 <sup>*7</sup>	COM2 <sup>*7</sup>	COM2 <sup>*7</sup>

\*1 The RI/5V can be switched. Use the IPC's switch to change if necessary.

\*2 Set up the SIO type with the DIP Switch. Please set up as follows according to SIO type to be used.

\*3 When making communication between an External Device and COM port on the Expansion slot, only RS-232C is supported. However, ER (DTR/CTS) control cannot be executed because of the specification of COM port.

For connection with External Device, use user-created cables and disable Pin Nos. 1, 4, 6 and 9. Please refer to the IPC manual for details of pin layout.

\*4 Set up the SIO type with the BIOS. Please refer to the IPC manual for details of BIOS.

- \*5 When setting up communication between an External Device and the RS-232C/422/485 interface module, use the IPC (RS-232C) or PS5000 (RS-422/485) cable diagrams. However, when using PFXZPBMPR42P2 in a RS-422/485 (4-wire) configuration with no flow control, connect 7.RTS+ and 8.CTS+, and connect 6.RTS- and 9.CTS-.  
When using RS-422/485 communication with External Devices, you may need to reduce the transmission speed and increase the TX Wait time.
- \*6 To use RS-422/485 communication on the RS-232C/422/485 interface module, the DIP Switch setting is required. Please refer to "Knowledge Base" (FAQs) on the support site. (<http://www.pro-face.com/trans/en/manual/1001.html>)

Settings	FAQ ID
PFXZPBMPR42P2, RS422/485 change method	FA263858
PFXZPBMPR42P2 termination resistor setting	FA263974
PFXZPBMPR44P2, RS422/485 change method	FA264087
PFXZPBMPR44P2 termination resistor setting	FA264088

- \*7 Set up the SIO type with the DIP Switch. Please refer to the IPC manual for details of DIP Switch. The BOX Atom has not a switch to set the RS-232C, RS-422/485 mode. Use the BIOS for the setting.
- \*8 For the connection with the External Device, on the user-created cable read as if the connector on the Display-side is a M12 A-coding 8 pin socket. The pin assignment is the same as described in the cable diagram. For the M12 A-coding connector, use PFXZPSCNM122.

## DIP Switch settings (PL3000 / PS3000 Series)

### RS-232C

DIP Switch	Setting	Description
1	OFF*1	Reserved (always OFF)
2	OFF	SIO type: RS-232C
3	OFF	
4	OFF	Output mode of SD (TXD) data: Always output
5	OFF	Terminal resistance (220Ω) insertion to SD (TXD): None
6	OFF	Terminal resistance (220Ω) insertion to RD (RXD): None
7	OFF	Short-circuit of SDA (TXA) and RDA (RXA): Not available
8	OFF	Short-circuit of SDB (TXB) and RDB (RXB): Not available
9	OFF	RS (RTS) Auto control mode: Disabled
10	OFF	

\*1 When using PS-3450A, PS-3451A, PS3000-BA and PS3001-BD, turn ON the set value.

## RS-422/485 (4 wire)

DIP Switch	Setting	Description
1	OFF	Reserved (always OFF)
2	ON	SIO type: RS-422/485
3	ON	
4	OFF	Output mode of SD (TXD) data: Always output
5	OFF	Terminal resistance (220Ω) insertion to SD (TXD): None
6	OFF	Terminal resistance (220Ω) insertion to RD (RXD): None
7	OFF	Short-circuit of SDA (TXA) and RDA (RXA): Not available
8	OFF	Short-circuit of SDB (TXB) and RDB (RXB): Not available
9	OFF	RS (RTS) Auto control mode: Disabled
10	OFF	

## RS-422/485 (2 wire)

DIP Switch	Setting	Description
1	OFF	Reserved (always OFF)
2	ON	SIO type: RS-422/485
3	ON	
4	OFF	Output mode of SD (TXD) data: Always output
5	OFF	Terminal resistance (220Ω) insertion to SD (TXD): None
6	OFF	Terminal resistance (220Ω) insertion to RD (RXD): None
7	ON	Short-circuit of SDA (TXA) and RDA (RXA): Available
8	ON	Short-circuit of SDB (TXB) and RDB (RXB): Available
9	ON	RS (RTS) Auto control mode: Enabled
10	ON	

## 2 External Device Selection

Select the External Device to connect to the Display.

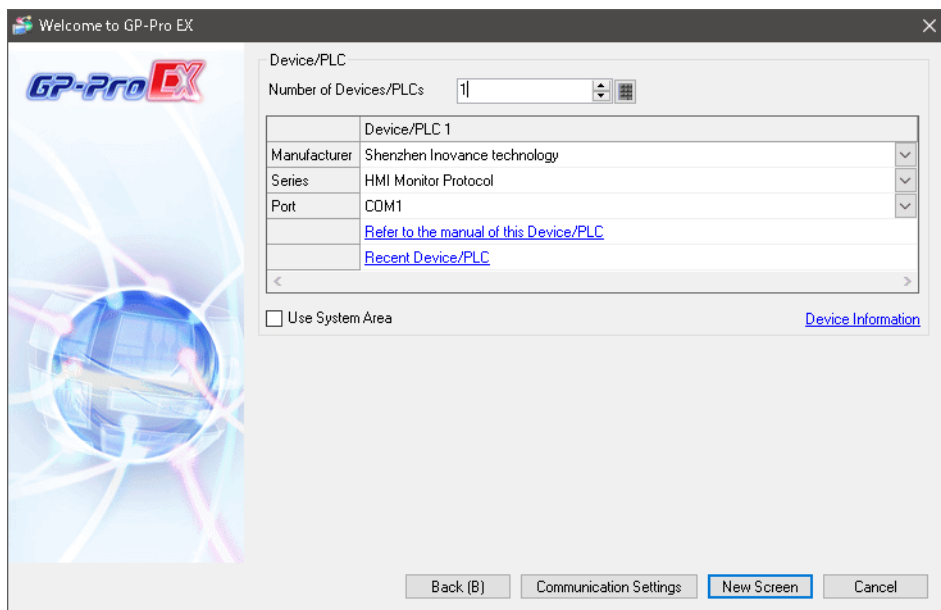

Setup Items	Setup Description
Number of Devices/PLCs	Enter an integer from 1 to 4 to define the number of Devices/PLCs to connect to the display.
Manufacturer	Select the manufacturer of the External Device to connect. Select "Shenzhen Inovance technology".
Series	Select the External Device model (series) and the connection method. Select "HMI Monitor Protocol". In System configuration, make sure the External Device you are connecting is supported by "HMI Monitor Protocol". ☞ "1 System Configuration" (page 3)
Port	Select the Display port to connect to the External Device.
Use System Area	Check this option to synchronize the system data area of the Display and the device (memory) of the External Device. When synchronized, you can use the External Device's ladder program to switch the display or display the window on the Display. Cf. GP-Pro EX Reference Manual "LS Area (Direct Access Method Area)" This feature can also be set in GP-Pro EX or in the Display's offline mode. Cf. GP-Pro EX Reference Manual "System Settings [Display Unit] - [System Area] Settings Guide" Cf. Maintenance/Troubleshooting Guide "Main Unit - System Area Settings"



## 3 Communication Settings

This section provides examples of communication settings recommended by Pro-face for the Display and the External Device.

### 3.1 Setting Example 1

#### ■ GP-Pro EX Settings

#### ◆ Communication Settings

To display the setup screen, from the [Project] menu, point to [System Settings] and select [Device/PLC].

Device/PLC 1

Summary [Change Device/PLC](#)

Manufacturer  Series  Port

Text Data Mode  [Change](#)

Communication Settings

RS232C     RS422/485(2wire)     RS422/485(4wire)  
 Speed   
 Data Length  7     8  
 Parity  NONE     EVEN     ODD  
 Stop Bit  1     2  
 Flow Control  NONE     ER(DTR/CTS)     XON/XOFF  
 Timeout  (sec)  
 Retry   
 Wait To Send  (ms)

RI / VCC     RI     VCC  
In the case of RS232C, you can select the 9th pin to RI (Input) or VCC (5V Power Supply). If you use the Digital's RS232C Isolation Unit, please select it to VCC.

Device-Specific Settings

Allowable Number of Devices/PLCs: 1   

No.	Device Name	Settings
1	<input type="text" value="PLC1"/>	<input type="text" value="Series=H1U/H2U"/>

#### ◆ Device Setting

To display the [Individual Device Settings] dialog box, from [Device-Specific Settings] in the [Device/PLC] window, select the external device and click [Settings] .

Individual Device Settings

PLC1

Series

If you change series, please reconfirm all address settings.

## ■ External Device Settings

Use the Shenzhen Inovance ladder software (AutoShop Ver.3.01 or later) to configure communication settings for the External Device.

Refer to your External Device manual for details.

- (1) Start up the ladder software.
- (2) Select [New Project].
- (3) Configure the setup items as follows, and click [OK].

Setup Items	Setup Description
Project Name	Enter the project name.
Project Path	Select the save destination.
PLC Type	Select the series of the External Device.

- (4) In tree view, from [Communication Config] click the COM port that you will use and display the [COM Config] dialog box.
- (5) Configure the setup items as follows.

Setup Items	Setup Description
Protocol	Download/HMI Monitor Protocol site
Baud rate	9600
Data Length	7bit
Parity	Even
Stop Bit (s)	1bit
Station	1
Time Out	10

- (6) Click [OK] to complete the configuration.
- (7) Click [Write] to write the settings to the External Device.

## 3.2 Setting Example 2

### ■ GP-Pro EX Settings

#### ◆ Communication Settings

To display the setup screen, from the [Project] menu, point to [System Settings] and select [Device/PLC].

Device/PLC 1

Summary [Change Device/PLC](#)

Manufacturer  Series  Port

Text Data Mode  [Change](#)

Communication Settings

SI0 Type  RS232C  RS422/485(2wire)  RS422/485(4wire)

Speed

Data Length  7  8

Parity  NONE  EVEN  ODD

Stop Bit  1  2

Flow Control  NONE  ER(DTR/CTS)  XON/XOFF

Timeout  (sec)

Retry

Wait To Send  (ms)

RI / VCC  RI  VCC  
In the case of RS232C, you can select the 9th pin to RI (Input) or VCC (5V Power Supply). If you use the Digital's RS232C Isolation Unit, please select it to VCC.

Device-Specific Settings

Allowable Number of Devices/PLCs

No.	Device Name	Settings	<input type="button" value="Add Indirect Device"/>
1	<input type="text" value="PLC1"/>	<input type="text" value="Series=H1U/H2U"/>	<input type="button" value="Add Indirect Device"/>

#### ◆ Device Setting

To display the [Individual Device Settings] dialog box, from [Device-Specific Settings] in the [Device/PLC] window, select the external device and click [Settings] .

Individual Device Settings

PLC1

Series

If you change series, please reconfirm all address settings.

## ■ External Device Settings

Use the Shenzhen Inovance ladder software (AutoShop Ver.3.01 or later) to configure communication settings for the External Device.

Refer to your External Device manual for details.

- (1) Start up the ladder software.
- (2) Select [New Project].
- (3) Configure the setup items as follows, and click [OK].

Setup Items	Setup Description
Project Name	Enter the project name.
Project Path	Select the save destination.
PLC Type	Select the series of the External Device.

- (4) In tree view, from [Communication Config] click the COM port that you will use and display the [COM Config] dialog box.
- (5) Configure the setup items as follows.

Setup Items	Setup Description
Protocol	Download/HMI Monitor Protocol site
Baud rate	9600
Data Length	7bit
Parity	Even
Stop Bit (s)	1bit
Station	1
Time Out	10

- (6) Click [OK] to complete the configuration.
- (7) Click [Write] to write the settings to the External Device.

### 3.3 Setting Example 3

#### ■ GP-Pro EX Settings

##### ◆ Communication Settings

To display the setup screen, from the [Project] menu, point to [System Settings] and select [Device/PLC].

Device/PLC 1 [Change Device/PLC](#)

Summary  
 Manufacturer  Series  Port

Text Data Mode  [Change](#)

Communication Settings

SIQ Type  RS232C  RS422/485(2wire)  RS422/485(4wire)

Speed

Data Length  7  8

Parity  NONE  EVEN  ODD

Stop Bit  1  2

Flow Control  NONE  ER(DTR/CTS)  XON/XOFF

Timeout  (sec)

Retry

Wait To Send  (ms)

RI / VCC  RI  VCC  
In the case of RS232C, you can select the 9th pin to RI (Input) or VCC (5V Power Supply). If you use the Digital's RS232C Isolation Unit, please select it to VCC.

Device-Specific Settings

Allowable Number of Devices/PLCs

No.	Device Name	Settings	<input type="button" value="Add Indirect Device"/>
1	<input type="text" value="PLC1"/>	<input type="text" value="Series=H1U/H2U"/>	<input type="button" value="Add Indirect Device"/>

##### ◆ Device Setting

To display the [Individual Device Settings] dialog box, from [Device-Specific Settings] in the [Device/PLC] window, select the external device and click [Settings] .

Individual Device Settings

PLC1

Series

If you change series, please reconfirm all address settings.

## ■ External Device Settings

Use the Shenzhen Inovance ladder software (AutoShop Ver.3.01 or later) to configure communication settings for the External Device.

Refer to your External Device manual for details.

- (1) Start up the ladder software.
- (2) Select [New Project].
- (3) Configure the setup items as follows, and click [OK].

Setup Items	Setup Description
Project Name	Enter the project name.
Project Path	Select the save destination.
PLC Type	Select the series of the External Device.

- (4) In tree view, from [Communication Config] click the COM port that you will use and display the [COM Config] dialog box.
- (5) Configure the setup items as follows.

Setup Items	Setup Description
Protocol	Download/HMI Monitor Protocol site
Baud rate	9600
Data Length	7bit
Parity	Even
Stop Bit (s)	1bit
Station	1
Time Out	10

- (6) Click [OK] to complete the configuration.
- (7) Click [Write] to write the settings to the External Device.

### 3.4 Setting Example 4

#### ■ GP-Pro EX Settings

##### ◆ Communication Settings

To display the setup screen, from the [Project] menu, point to [System Settings] and select [Device/PLC].

Device/PLC 1

Summary [Change Device/PLC](#)

Manufacturer  Series  Port

Text Data Mode  [Change](#)

Communication Settings

SIQ Type  RS232C  RS422/485(2wire)  RS422/485(4wire)

Speed

Data Length  7  8

Parity  NONE  EVEN  ODD

Stop Bit  1  2

Flow Control  NONE  ER(DTR/CTS)  XON/XOFF

Timeout  (sec)

Retry

Wait To Send  (ms)

RI / VCC  RI  VCC

In the case of RS232C, you can select the 9th pin to RI (Input) or VCC (5V Power Supply). If you use the Digital's RS232C Isolation Unit, please select it to VCC.

Device-Specific Settings

Allowable Number of Devices/PLCs

No.	Device Name	Settings
<input type="button" value="Add Device"/> 1	<input type="text" value="PLC1"/>	<input type="text" value="Series=H1U/H2U"/> <input type="button" value="Add Indirect Device"/>

##### ◆ Device Setting

To display the [Individual Device Settings] dialog box, from [Device-Specific Settings] in the [Device/PLC] window, select the external device and click [Settings] .

Individual Device Settings

PLC1

Series

If you change series, please reconfirm all address settings.

## ■ External Device Settings

Use the Shenzhen Inovance ladder software (AutoShop Ver.3.01 or later) to configure communication settings for the External Device.

Refer to your External Device manual for details.

- (1) Start up the ladder software.
- (2) Select [New Project].
- (3) Configure the setup items as follows, and click [OK].

Setup Items	Setup Description
Project Name	Enter the project name.
Project Path	Select the save destination.
PLC Type	Select the series of the External Device.

- (4) In tree view, from [Communication Config] click the COM port that you will use and display the [COM Config] dialog box.
- (5) Configure the setup items as follows.

Setup Items	Setup Description
Operate communication setting	Select the check box.
Protocol	HMI Monitor Protocol
H/W type	RS485
Baud rate	9600
Data Length	7bit
Parity	Even
Stop Bit (s)	1bit
Station	1
Time Out	10

- (6) Click [OK] to complete the configuration.
- (7) Click [Write] to write the settings to the External Device.



## 3.5 Setting Example 5

### ■ GP-Pro EX Settings

#### ◆ Communication Settings

To display the setup screen, from the [Project] menu, point to [System Settings] and select [Device/PLC].

Device/PLC 1

Summary [Change Device/PLC](#)

Manufacturer  Series  Port

Text Data Mode  [Change](#)

Communication Settings

SI0 Type  RS232C  RS422/485(2wire)  RS422/485(4wire)

Speed

Data Length  7  8

Parity  NONE  EVEN  ODD

Stop Bit  1  2

Flow Control  NONE  ER(DTR/CTS)  XON/XOFF

Timeout  (sec)

Retry

Wait To Send  (ms)

RI / VCC  RI  VCC  
In the case of RS232C, you can select the 9th pin to RI (Input) or VCC (5V Power Supply). If you use the Digital's RS232C Isolation Unit, please select it to VCC.

Device-Specific Settings

Allowable Number of Devices/PLCs

No.	Device Name	Settings
<input type="button" value="1"/>	<input type="text" value="PLC1"/>	<input type="text" value="Series=H1U/H2U"/>

#### ◆ Device Setting

To display the [Individual Device Settings] dialog box, from [Device-Specific Settings] in the [Device/PLC] window, select the external device and click [Settings] .

Individual Device Settings

PLC1

Series

If you change series, please reconfirm all address settings.

## ■ External Device Settings

Use the Shenzhen Inovance ladder software (AutoShop Ver.3.01 or later) to configure communication settings for the External Device.

Refer to your External Device manual for details.

- (1) Start up the ladder software.
- (2) Select [New Project].
- (3) Configure the setup items as follows, and click [OK].

Setup Items	Setup Description
Project Name	Enter the project name.
Project Path	Select the save destination.
PLC Type	Select the series of the External Device.

- (4) In tree view, from [Communication Config] click the COM port that you will use and display the [COM Config] dialog box.
- (5) Configure the setup items as follows.

Setup Items	Setup Description
Operate communication setting	Select the check box.
Protocol	HMI Monitor Protocol
H/W type	RS232C/RS422
Baud rate	9600
Data Length	7bit
Parity	Even
Stop Bit (s)	1bit
Station	1
Time Out	10

- (6) Click [OK] to complete the configuration.
- (7) Click [Write] to write the settings to the External Device.

## 3.6 Setting Example 6

### ■ GP-Pro EX Settings

#### ◆ Communication Settings

To display the setup screen, from the [Project] menu, point to [System Settings] and select [Device/PLC].

Device/PLC 1 [Change Device/PLC](#)

Summary  
 Manufacturer  Series  Port

Text Data Mode  [Change](#)

Communication Settings

SI0 Type  RS232C  RS422/485(2wire)  RS422/485(4wire)

Speed

Data Length  7  8

Parity  NONE  EVEN  ODD

Stop Bit  1  2

Flow Control  NONE  ER(DTR/CTS)  XON/XOFF

Timeout  (sec)

Retry

Wait To Send  (ms)

RI / VCC  RI  VCC  
 In the case of RS232C, you can select the 9th pin to RI (Input) or VCC (5V Power Supply). If you use the Digital's RS232C Isolation Unit, please select it to VCC.

Device-Specific Settings

Allowable Number of Devices/PLCs

No.	Device Name	Settings	<input type="button" value="Add Indirect Device"/>
1	<input type="text" value="PLC1"/>	<input type="text" value="Series=H3U"/>	<input type="button" value="Add Indirect Device"/>

#### ◆ Device Setting

To display the [Individual Device Settings] dialog box, from [Device-Specific Settings] in the [Device/PLC] window, select the external device and click [Settings] .

Individual Device Settings

PLC1

Series

If you change series, please reconfirm all address settings.

## ■ External Device Settings

Use the Shenzhen Inovance ladder software (AutoShop Ver.3.01 or later) to configure communication settings for the External Device.

Refer to your External Device manual for details.

- (1) Start up the ladder software.
- (2) Select [New Project].
- (3) Configure the setup items as follows, and click [OK].

Setup Items	Setup Description
Project Name	Enter the project name.
Project Path	Select the save destination.
PLC Type	Select the series of the External Device.

- (4) In tree view, from [Communication Config] click the COM port that you will use and display the [COM Config] dialog box.
- (5) Configure the setup items as follows.

Setup Items	Setup Description
Protocol	Download/HMI Monitor Protocol site
Baud rate	9600
Data Length	7bit
Parity	Even
Stop Bit (s)	1bit
Station	1
Time Out	10

- (6) Click [OK] to complete the configuration.
- (7) Click [Write] to write the settings to the External Device.

## 3.7 Setting Example 7

### ■ GP-Pro EX Settings

#### ◆ Communication Settings

To display the setup screen, from the [Project] menu, point to [System Settings] and select [Device/PLC].

Device/PLC 1

Summary [Change Device/PLC](#)

Manufacturer  Series  Port

Text Data Mode  [Change](#)

Communication Settings

SIQ Type  RS232C  RS422/485(2wire)  RS422/485(4wire)

Speed

Data Length  7  8

Parity  NONE  EVEN  ODD

Stop Bit  1  2

Flow Control  NONE  ER(DTR/CTS)  XON/XOFF

Timeout  (sec)

Retry

Wait To Send  (ms)

RI / VCC  RI  VCC  
In the case of RS232C, you can select the 9th pin to RI (Input) or VCC (5V Power Supply). If you use the Digital's RS232C Isolation Unit, please select it to VCC.

Device-Specific Settings

Allowable Number of Devices/PLCs

No.	Device Name	Settings
<input type="button" value="1"/>	<input type="text" value="PLC1"/>	<input type="text" value="Series=H3U"/>

#### ◆ Device Setting

To display the [Individual Device Settings] dialog box, from [Device-Specific Settings] in the [Device/PLC] window, select the external device and click [Settings] .

Individual Device Settings

PLC1

Series

If you change series, please reconfirm all address settings.

## ■ External Device Settings

Use the Shenzhen Inovance ladder software (AutoShop Ver.3.01 or later) to configure communication settings for the External Device.

Refer to your External Device manual for details.

- (1) Start up the ladder software.
- (2) Select [New Project].
- (3) Configure the setup items as follows, and click [OK].

Setup Items	Setup Description
Project Name	Enter the project name.
Project Path	Select the save destination.
PLC Type	Select the series of the External Device.

- (4) In tree view, from [Communication Config] click the COM port that you will use and display the [COM Config] dialog box.
- (5) Configure the setup items as follows.

Setup Items	Setup Description
Protocol	Download/HMI Monitor Protocol site
Baud rate	9600
Data Length	7bit
Parity	Even
Stop Bit (s)	1bit
Station	1
Time Out	10

- (6) Click [OK] to complete the configuration.
- (7) Click [Write] to write the settings to the External Device.

## 3.8 Setting Example 8

### ■ GP-Pro EX Settings

#### ◆ Communication Settings

To display the setup screen, from the [Project] menu, point to [System Settings] and select [Device/PLC].

Device/PLC 1 [Change Device/PLC](#)

Summary  
 Manufacturer  Series  Port

Text Data Mode  [Change](#)

Communication Settings

SIQ Type  RS232C  RS422/485(2wire)  RS422/485(4wire)

Speed

Data Length  7  8

Parity  NONE  EVEN  ODD

Stop Bit  1  2

Flow Control  NONE  ER(DTR/CTS)  XON/XOFF

Timeout  (sec)

Retry

Wait To Send  (ms)

RI / VCC  RI  VCC  
In the case of RS232C, you can select the 9th pin to RI (Input) or VCC (5V Power Supply). If you use the Digital's RS232C Isolation Unit, please select it to VCC.

Device-Specific Settings

Allowable Number of Devices/PLCs: 1

No.	Device Name	Settings
1	<input type="text" value="PLC1"/>	<input type="text" value="Series=H3U"/>

#### ◆ Device Setting

To display the [Individual Device Settings] dialog box, from [Device-Specific Settings] in the [Device/PLC] window, select the external device and click [Settings] .

Individual Device Settings

PLC1

Series

If you change series, please reconfirm all address settings.

## ■ External Device Settings

Use the Shenzhen Inovance ladder software (AutoShop Ver.3.01 or later) to configure communication settings for the External Device.

Refer to your External Device manual for details.

- (1) Start up the ladder software.
- (2) Select [New Project].
- (3) Configure the setup items as follows, and click [OK].

Setup Items	Setup Description
Project Name	Enter the project name.
Project Path	Select the save destination.
PLC Type	Select the series of the External Device.

- (4) In tree view, from [Communication Config] click the COM port that you will use and display the [COM Config] dialog box.
- (5) Configure the setup items as follows.

Setup Items	Setup Description
Protocol	Download/HMI Monitor Protocol site
Baud rate	9600
Data Length	7bit
Parity	Even
Stop Bit (s)	1bit
Station	1
Time Out	10

- (6) Click [OK] to complete the configuration.
- (7) Click [Write] to write the settings to the External Device.



## 3.9 Setting Example 9

### ■ GP-Pro EX Settings

#### ◆ Communication Settings

To display the setup screen, from the [Project] menu, point to [System Settings] and select [Device/PLC].

Device/PLC 1

Summary [Change Device/PLC](#)

Manufacturer  Series  Port

Text Data Mode  [Change](#)

Communication Settings

SIQ Type  RS232C  RS422/485(2wire)  RS422/485(4wire)

Speed

Data Length  7  8

Parity  NONE  EVEN  ODD

Stop Bit  1  2

Flow Control  NONE  ER(DTR/CTS)  XON/XOFF

Timeout  (sec)

Retry

Wait To Send  (ms)

RI / VCC  RI  VCC  
In the case of RS232C, you can select the 9th pin to RI (Input) or VCC (5V Power Supply). If you use the Digital's RS232C Isolation Unit, please select it to VCC.

Device-Specific Settings

Allowable Number of Devices/PLCs

No.	Device Name	Settings
<input type="button" value="1"/>	<input type="text" value="PLC1"/>	<input type="text" value="Series=H3U"/>

#### ◆ Device Setting

To display the [Individual Device Settings] dialog box, from [Device-Specific Settings] in the [Device/PLC] window, select the external device and click [Settings] .

Individual Device Settings

PLC1

Series

If you change series, please reconfirm all address settings.

## ■ External Device Settings

Use the Shenzhen Inovance ladder software (AutoShop Ver.3.01 or later) to configure communication settings for the External Device.

Refer to your External Device manual for details.

- (1) Start up the ladder software.
- (2) Select [New Project].
- (3) Configure the setup items as follows, and click [OK].

Setup Items	Setup Description
Project Name	Enter the project name.
Project Path	Select the save destination.
PLC Type	Select the series of the External Device.

- (4) In tree view, from [Communication Config] click the COM port that you will use and display the [COM Config] dialog box.
- (5) Configure the setup items as follows.

Setup Items	Setup Description
Operate communication setting	Select the check box.
Protocol	HMI Monitor Protocol
H/W type	RS485
Baud rate	9600
Data Length	7bit
Parity	Even
Stop Bit (s)	1bit
Station	1
Time Out	10

- (6) Click [OK] to complete the configuration.
- (7) Click [Write] to write the settings to the External Device.

## 4 Setup Items

Set up the Display's communication settings in GP-Pro EX or in the Display's offline mode.

The setting of each parameter must match that of the External Device.

 "3 Communication Settings" (page 9)

### 4.1 Setup Items in GP-Pro EX

#### ■ Communication Settings

To display the setup screen, from the [Project] menu, point to [System Settings] and select [Device/PLC].

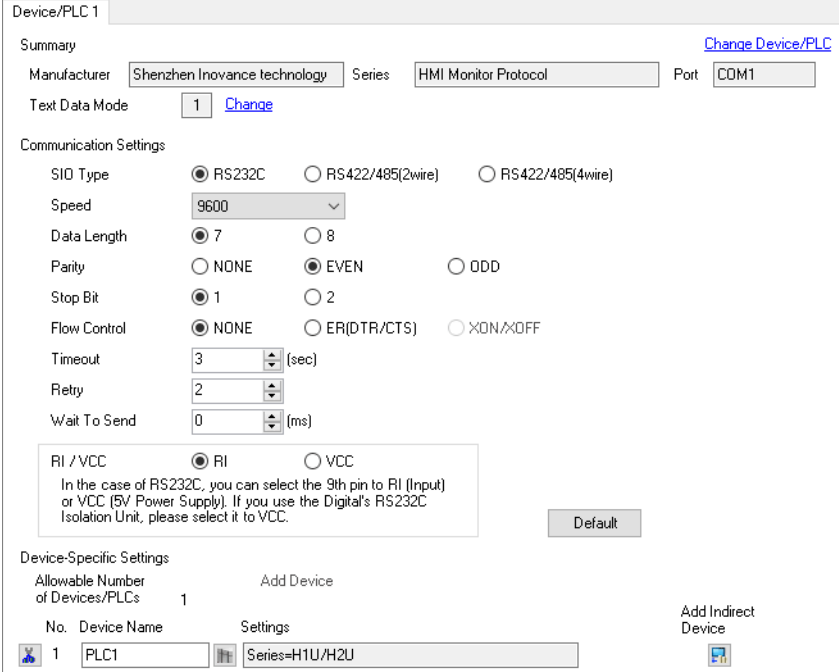

Device/PLC 1 [Change Device/PLC](#)

Summary  
 Manufacturer  Series  Port

Text Data Mode  [Change](#)

Communication Settings

SIO Type  RS232C  RS422/485(2wire)  RS422/485(4wire)

Speed

Data Length  7  8

Parity  NONE  EVEN  ODD

Stop Bit  1  2

Flow Control  NONE  ER(DTR/CTS)  XON/XOFF

Timeout  (sec)

Retry

Wait To Send  (ms)

RI / VCC  RI  VCC  
In the case of RS232C, you can select the 9th pin to RI (Input) or VCC (5V Power Supply). If you use the Digital's RS232C Isolation Unit, please select it to VCC.

Device-Specific Settings

Allowable Number of Devices/PLCs

No.	Device Name	Settings
1	PLC1	Series=H1U/H2U

Setup Items	Setup Description
SIO Type	Select the SIO type for communicating with the External Device.
Speed	Select the communication speed between the External Device and the Display.
Data Length	Select a data length.
Parity	Select how to check parity.
Stop Bit	Select a stop bit length.
Flow Control	Select the communication control method to prevent overflow of transmission and reception data.
Timeout	Enter the time (s) for which the Display waits for the response from the External Device, from "1 to 127".
Retry	In case of no response from the External Device, enter how many times the Display retransmits the command, from "0 to 255".
Wait To Send	Enter the standby time (ms) from when the Display receives packets until it transmits the next command, from "0 to 255".

**NOTE**

- Refer to the GP-Pro EX Reference Manual for Indirect Device.

Cf. GP-Pro EX Reference Manual "Changing the Device/PLC at Runtime (Indirect Device)"

■ **Device Setting**

To display the [Individual Device Settings] dialog box, from [Device-Specific Settings] in the [Device/PLC] window, select the external device and click [Settings] .

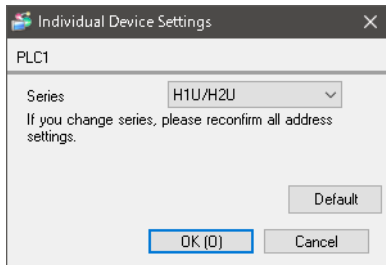

Setup Items	Setup Description
Series	Select the series of the External Device.

## 4.2 Setup Items in Offline Mode

**NOTE**

- Refer to the Maintenance/Troubleshooting guide for information on how to enter offline mode or about the operation.

Cf. Maintenance/Troubleshooting Guide "Offline Mode"

- The number of the setup items to be displayed for 1 page in the offline mode depends on the Display in use. Please refer to the Reference manual for details.

### ■ Communication Settings

To display the setting screen, touch [Device/PLC Settings] from [Peripheral Settings] in offline mode. Touch the External Device you want to set from the displayed list.

Comm.	Device	Option		
HMI Monitor Protocol		[COM1]	Page 1/1	
SIO Type	RS232C			
Speed	9600			
Data Length	<input checked="" type="radio"/> 7 <input type="radio"/> 8			
Parity	<input type="radio"/> NONE <input checked="" type="radio"/> EVEN <input type="radio"/> ODD			
Stop Bit	<input checked="" type="radio"/> 1 <input type="radio"/> 2			
Flow Control	NONE			
Timeout(s)	3			
Retry	2			
Wait To Send(ms)	0			
Exit		Back		2020/07/06 16:28:43

Setup Items	Setup Description
SIO Type	Select the SIO type for communicating with the External Device. <b>IMPORTANT</b> In the communication settings, set [SIO Type] correctly according to the serial interface specifications of the Display. If you select an SIO type that the serial interface does not support, proper operation cannot be guaranteed. Refer to your Display manual for details on the serial interface specifications.
Speed	Select the communication speed between the External Device and the Display.
Data Length	Select data length.
Parity	Select how to check parity.

Setup Items	Setup Description
Stop Bit	Select stop bit length.
Flow Control	The communication control method to prevent overflow of transmission and reception data.
Timeout	Enter the time (s) for which the Display waits for the response from the External Device, from "1 to 127".
Retry	In case of no response from the External Device, enter how many times the Display retransmits the command, from "0 to 255".
Wait To Send	Enter the standby time (ms) from when the Display receives packets until it transmits the next command, from "0 to 255".

## ■ Device Setting

To display the setting screen, touch [Device/PLC Settings] from [Peripheral Settings]. Touch the External Device you want to set from the list that appears, and touch [Device].

Comm.	Device	Option		
HMI Monitor Protocol		[COM1]	Page 1/1	
Device/PLC Name	<input type="text" value="PLC1"/>			
Series	H1U/H2U			
	Exit	Back	2020/07/06 16:28:49	

Setup Items	Setup Description
Device/PLC Name	Select the External Device to set. Device/PLC Name is the title of the External Device set with GP-Pro EX. (Initial value [PLC1])
Series	Displays the series of the External Device.

■ Option

To display the setting screen, touch [Device/PLC Settings] from [Peripheral Settings]. Touch the External Device you want to set from the list that appears, and touch [Option].

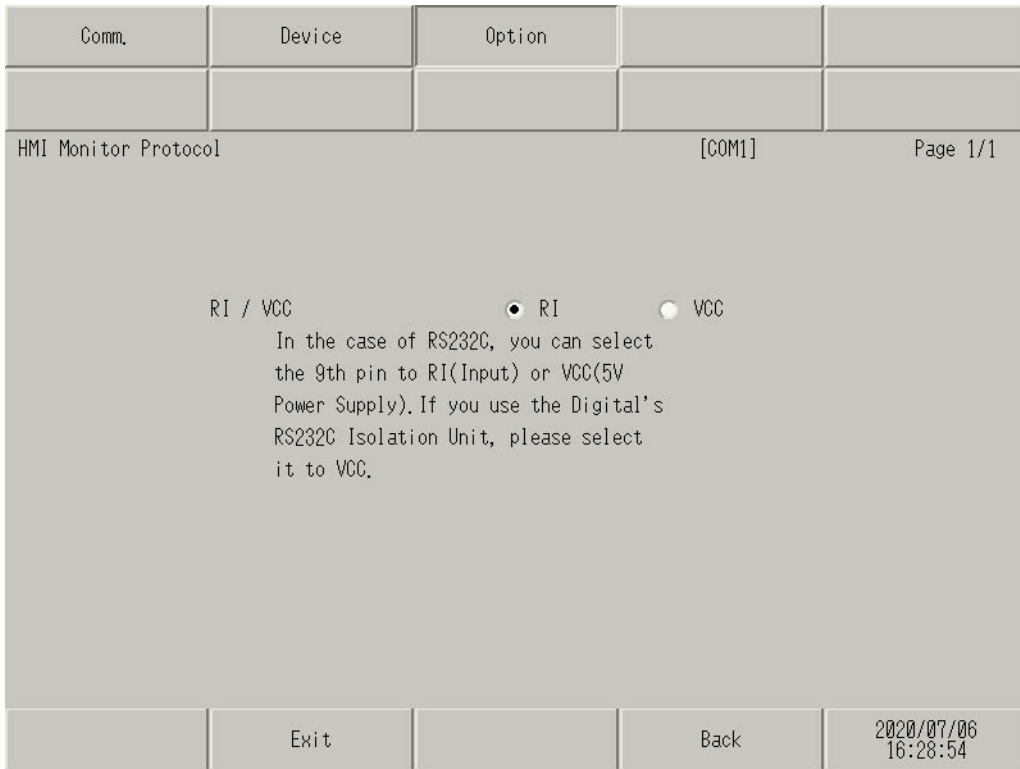

Setup Items	Setup Description
RI/VCC	You can switch between RI/VCC for the 9th pin when you select RS-232C for SIO type. To connect to the IPC, you need to switch between RI/5V using the IPC selector switch. Refer to your IPC manual for details.

**NOTE**

- GP-4100 series, GP-4\*01TM, GP-Rear Module, LT-4\*01TM and LT-Rear Module do not have the [Option] setting in the offline mode.

## 5 Cable Diagrams

The cable diagrams shown below may be different from the cable diagrams recommended by Shenzhen Inovance. Please be assured there is no operational problem in applying the cable diagrams shown in this manual.

- The FG pin on the External Device must be D-class grounded. Refer to your External Device manual for details.
- The SG and FG are connected inside the Display. If you connect the External Device to the SG, do not form any short-circuit loop in the system design.
- If the communication is not stable because of noise or other factors, connect an isolation unit.

Cable Diagram 1

Display (Connection Port)	Cable		Remarks
SP5000* <sup>1</sup> (COM1/2) SP-5B00 (COM1) GP4000* <sup>2</sup> (COM1) IPC* <sup>3</sup> PC/AT	1A	RS422-RS232C communication cable by Shenzhen Inovance technology H2U-232-CAB	The cable length must be 15m or less.
	1B	User-created cable + Function extension board by Shenzhen Inovance technology H1U-232-BD, H2U-232-BD* <sup>4</sup>	
GP-4105 (COM1) GP-4115T (COM1) GP-4115T3 (COM1)	1C	User-created cable + Function extension board by Shenzhen Inovance technology H1U-232-BD, H2U-232-BD* <sup>4</sup>	The cable length must be 15m or less.

\*1 Except SP-5B00

\*2 All GP4000 models except GP-4100 Series and GP-4203T

\*3 Available only with COM ports that support RS-232C.

 ■ IPC COM Port (page 5)

\*4 The corresponding Function Extension Board differs depending on the CPU.

CPU	Function Extension Board
H1U	H1U-232-BD
H2U	H2U-232-BD

1A)

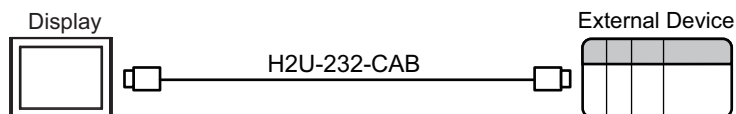



1B)

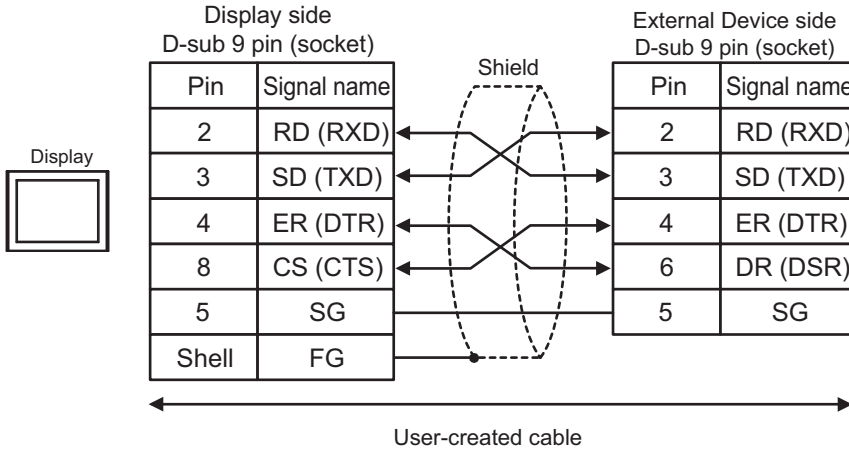

1C)

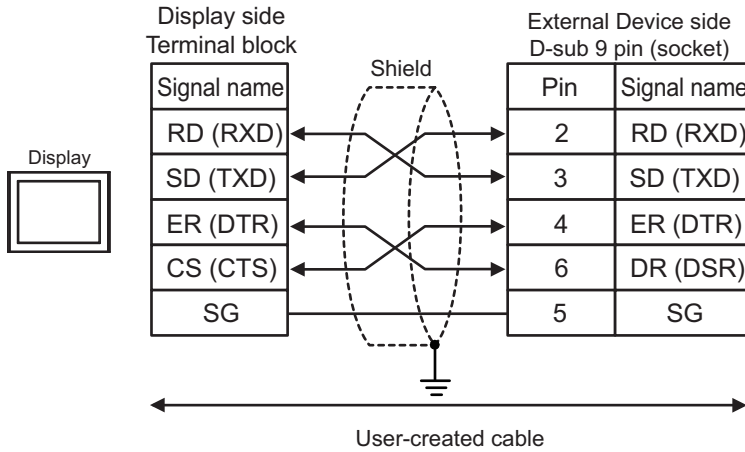

Cable Diagram 2

Display (Connection Port)	Cable		Notes
GP-4*01TM (COM1) GP-Rear Module (COM1)	2A	COM port conversion adapter by Pro-face CA3-ADPCOM-01 + Terminal block conversion adapter by Pro-face CA3-ADPTRM-01 + User-created cable	The cable length must be 15m or less.
	2B	User-created cable	
IPC*1	2C	COM port conversion adapter by Pro-face CA3-ADPCOM-01 + Terminal block conversion adapter by Pro-face CA3-ADPTRM-01 + User-created cable	The cable length must be 15m or less.
	2D	User-created cable	
GP-4106 (COM1) GP-4116T (COM1)	2E	User-created cable	The cable length must be 15m or less.
GP-4107 (COM1) GP-4*03T*2 (COM2) GP-4203T (COM1)	2F	User-created cable	The cable length must be 15m or less.
GP4000*3 (COM2) GP-4201T (COM1) SP5000*4 (COM1/2) SP-5B00 (COM2)	2G	RS-422 Terminal Block Conversion Adapter by Pro-face PFXZCBADTM1*5 + User-created cable	The cable length must be 15m or less.
	2B	User-created cable	
LT-4*01TM (COM1) LT-Rear Module (COM1)	2H	RJ45 RS-485 Cable (5m) by Pro-face PFXZLMCBJR81	The cable length must be 15m or less.
PE-4000B*6 PS5000*6	2I	User-created cable	The cable length must be 15m or less.

\*1 Only the COM port which can communicate by RS-422/485 (2 wire) can be used. (Except PE-4000B, PS5000)  
 ■ IPC COM Port (page 5)

\*2 Except GP-4203T

\*3 All GP4000 models except GP-4100 Series, GP-4\*01TM, GP-Rear Module, GP-4201T and GP-4\*03T

\*4 Except SP-5B00

\*5 When using a Terminal Block Conversion Adapter (CA3-ADPTRM-01) instead of the RS-422 Terminal Block Conversion Adapter, refer to Cable Diagram 2A.

\*6 Only the COM port which can communicate by RS-422/485 (2 wire) can be used.  
 ■ IPC COM Port (page 5)

2A)

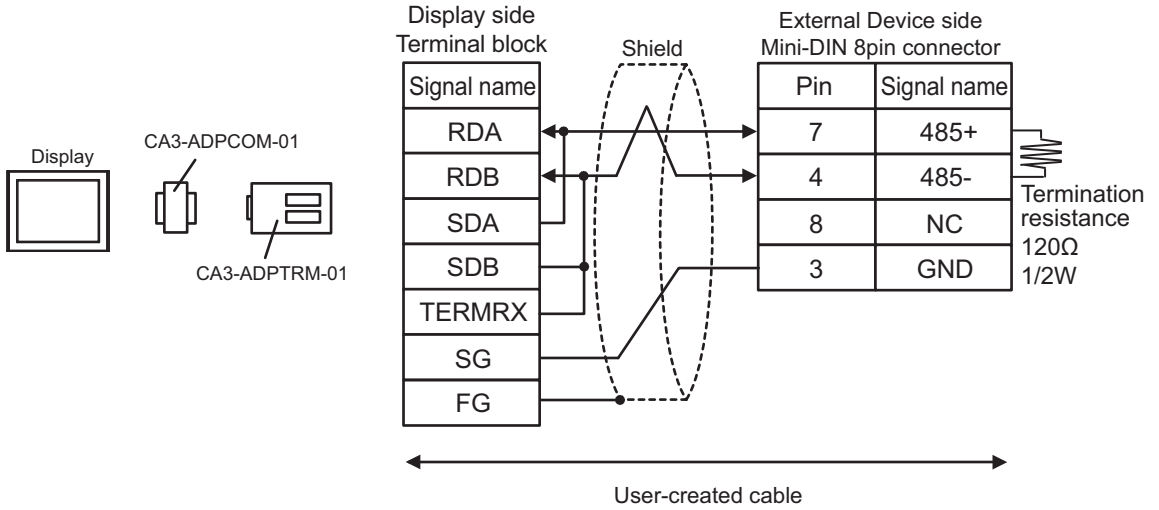

2B)

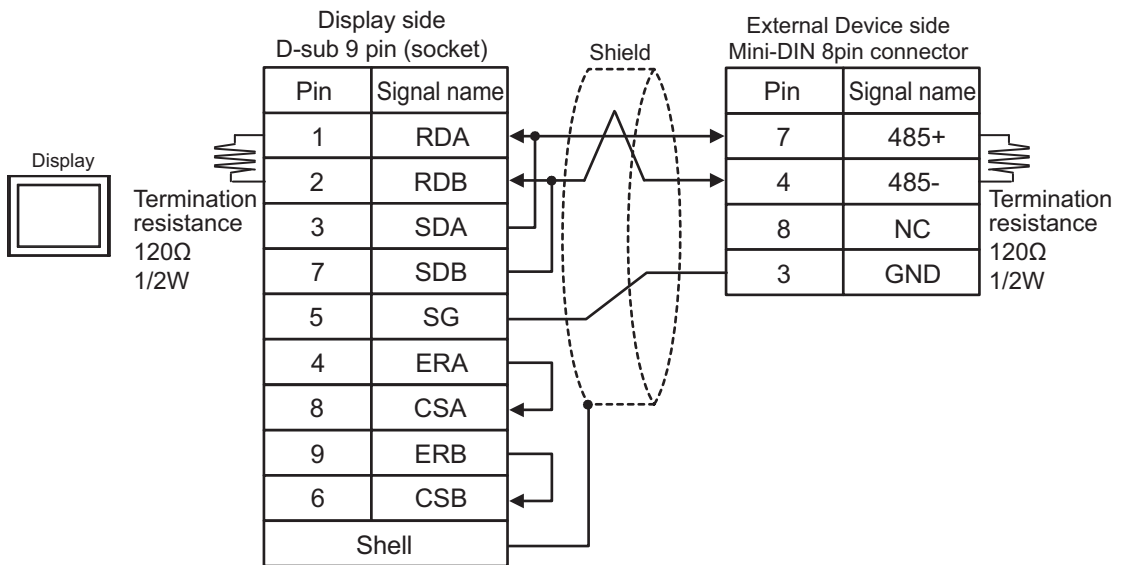

2C)

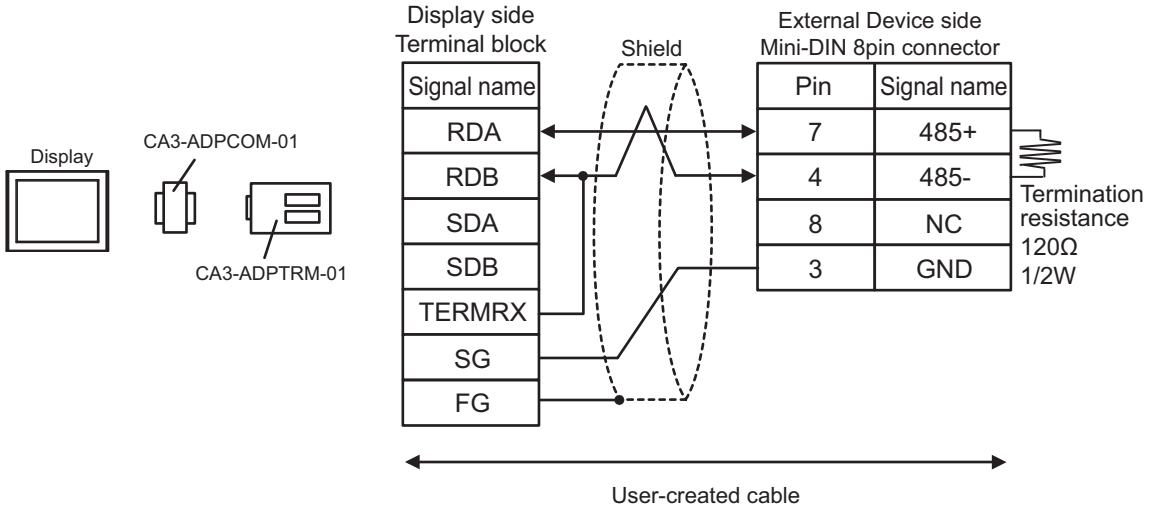

2D)

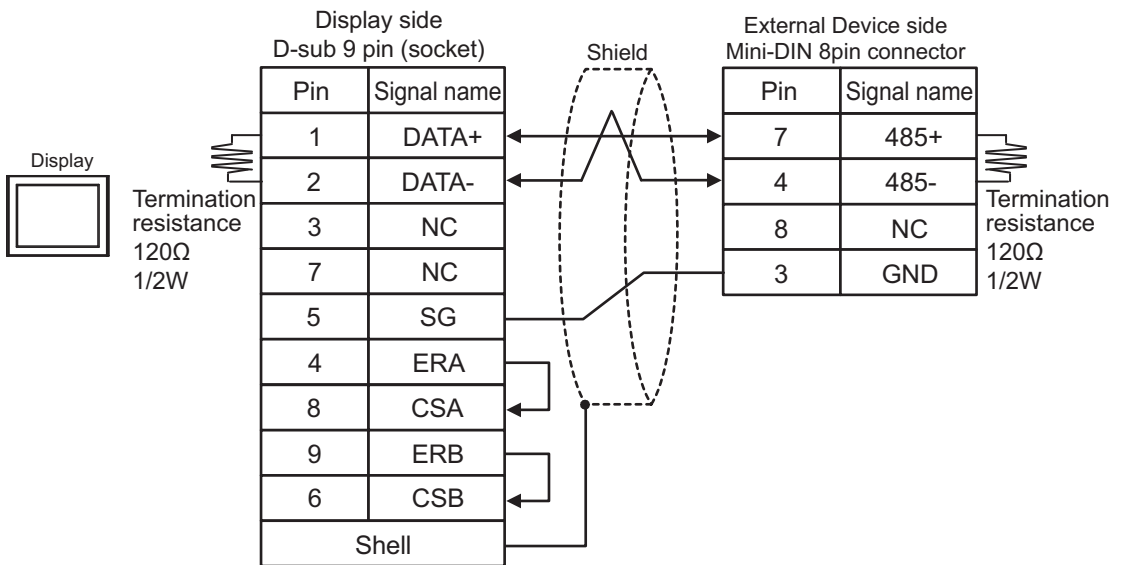

2E)

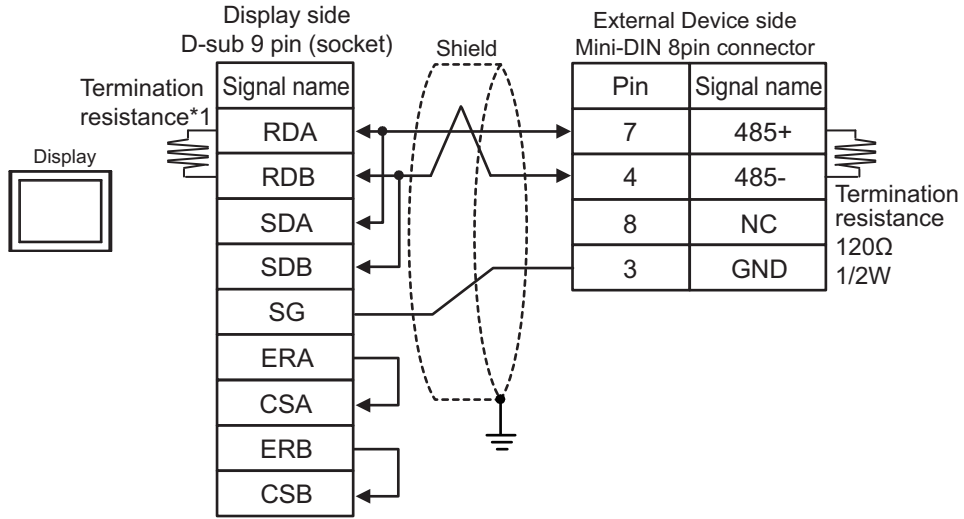

\*1 The resistance in the Display is used as the termination resistance. Set the value of the DIP Switch on the rear of the Display as shown in the table below.

DIP Switch No.	Set Value
1	OFF
2	OFF
3	ON
4	ON

2F)

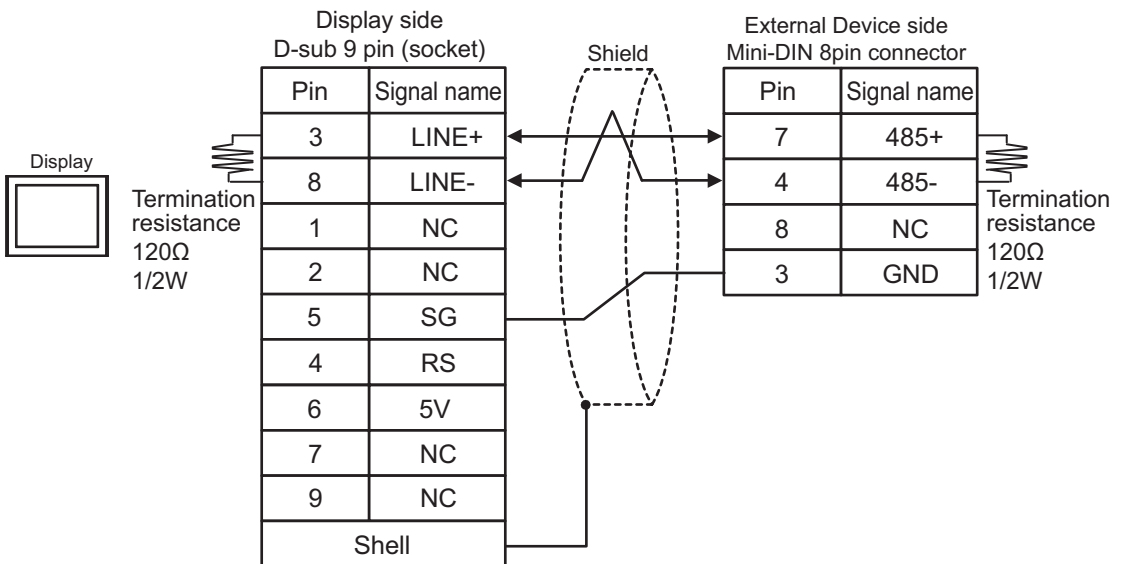

**NOTE**

- In COM on the GP-4107, the SG and FG terminals are isolated.

2G)

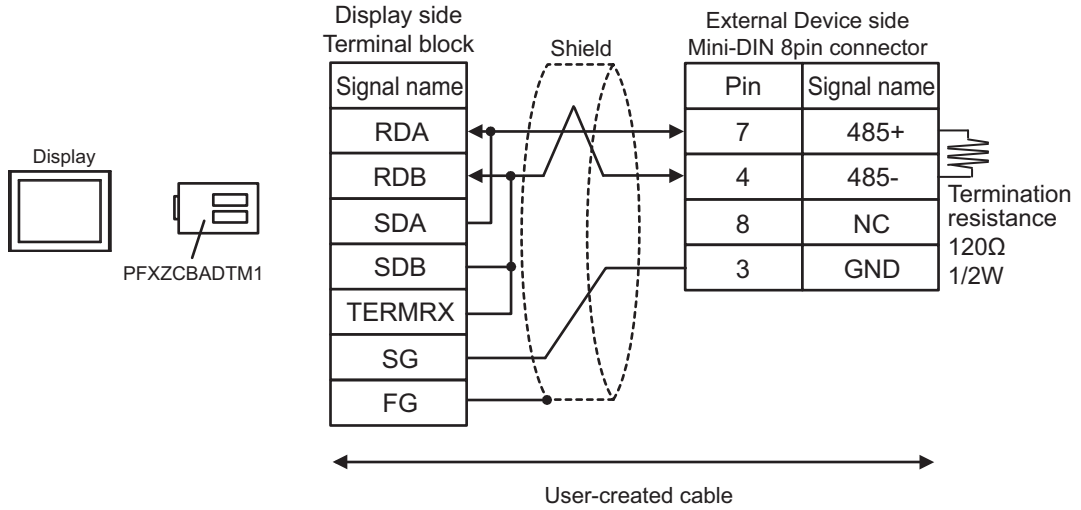

2H)

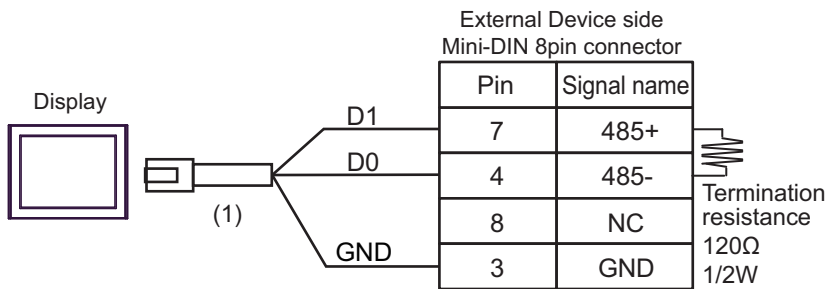

Number	Name	Notes
(1)	RJ45 RS-485 Cable (5m) by Pro-face PFXZLMCBRJ81	

2l)

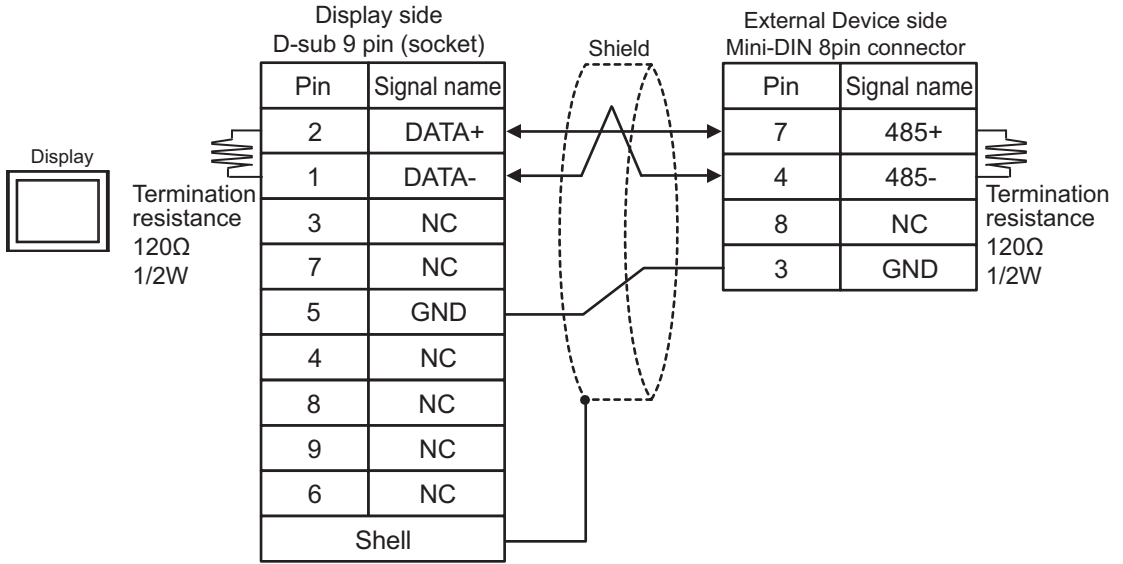

Cable Diagram 3

Display (Connection Port)	Cable		Remarks
GP-4*01TM (COM1) GP-Rear Module (COM1) IPC*1	3A	COM port conversion adapter by Pro-face CA3-ADPCOM-01 + Connector terminal block conversion adapter by Pro-face CA3-ADPTRM-01 + User-created cable	The cable length must be 1000m or less.
	3B	User-created cable	
	3C	COM port conversion adapter by Pro-face CA3-ADPCOM-01 + User-created cable + RS422 communication cable by Shenzhen Inovance technology IT5-H2U-CAB	
GP-4106 (COM1) GP-4116T (COM1)	3D	User-created cable	The cable length must be 1000m or less.
GP4000*2 (COM2) GP-4201T (COM1) SP5000*3 (COM1/2) SP-5B00 (COM2)	3E	RS-422 Terminal Block Conversion Adapter by Pro-face PFZCBAADTM1*4 + User-created cable	The cable length must be 1000m or less.
	3B	User-created cable	

\*1 Available only with COM ports that support RS-422/485 (4wire). (Except PE-4000B, PS5000)  
 ■ IPC COM Port (page 5)

\*2 All GP4000 models except GP-4100 Series, GP-4\*01TM, GP-Rear Module, GP-4201T and GP-4\*03T

\*3 Except SP-5B00

\*4 When using a Terminal Block Conversion Adapter (CA3-ADPTRM-01) instead of the RS-422 Terminal Block Conversion Adapter, refer to Cable Diagram 3A.

**IMPORTANT**

- Signal name to use for communication varies depending on the External Device. Signal names corresponding to each series are shown below.

Pin	Signal Name	
	H1U/H2U/H3U COM0	H2U-422-BD
1	RXD-	RB
2	RXD+	RA
3	GND	GND
4	TXD-	TB
5	+5V	VDD
6	CCS	NC
7	TXD+	TA
8	NC	NC



3A)

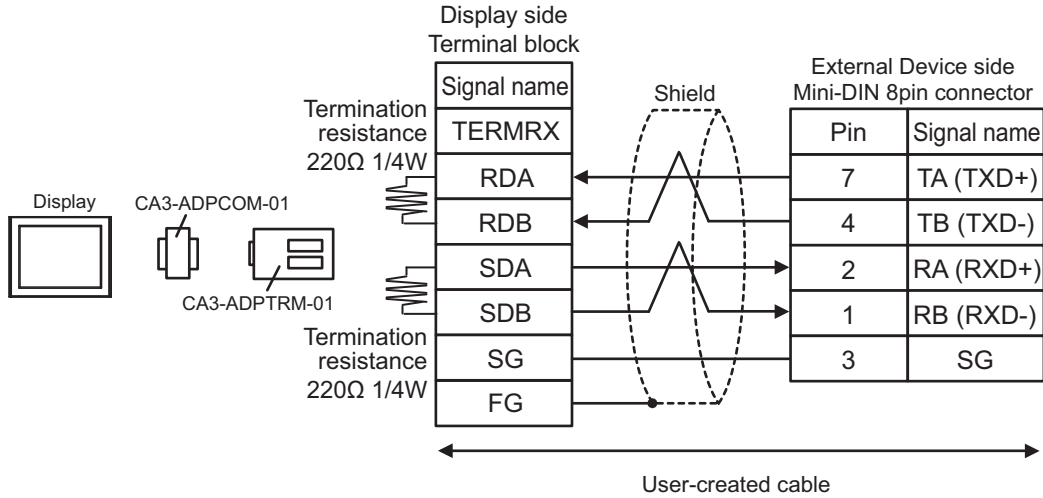

3B)

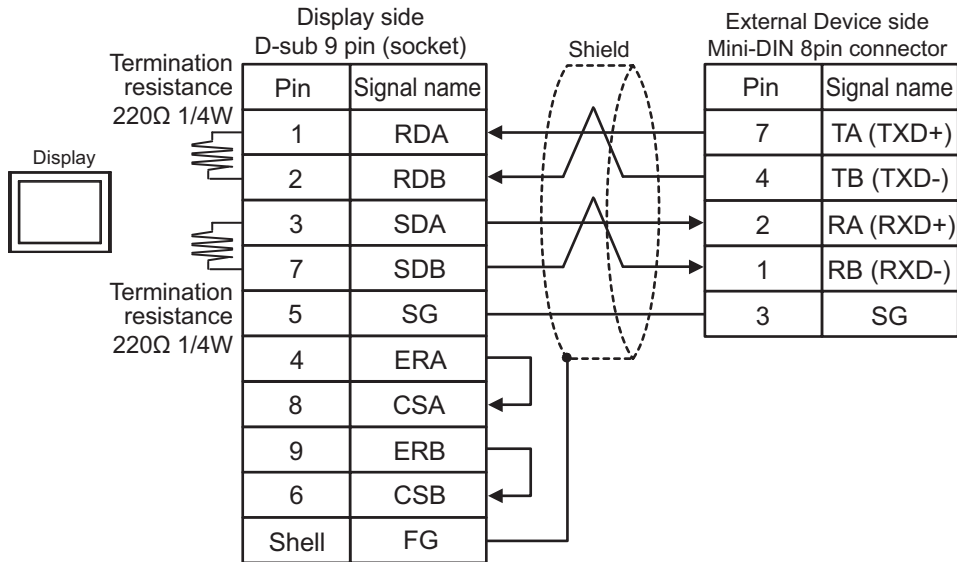

3C)

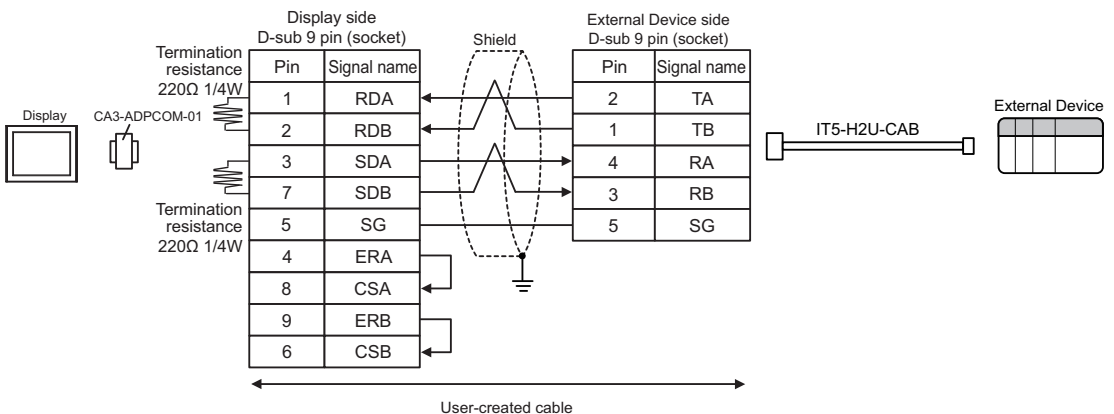

3D)

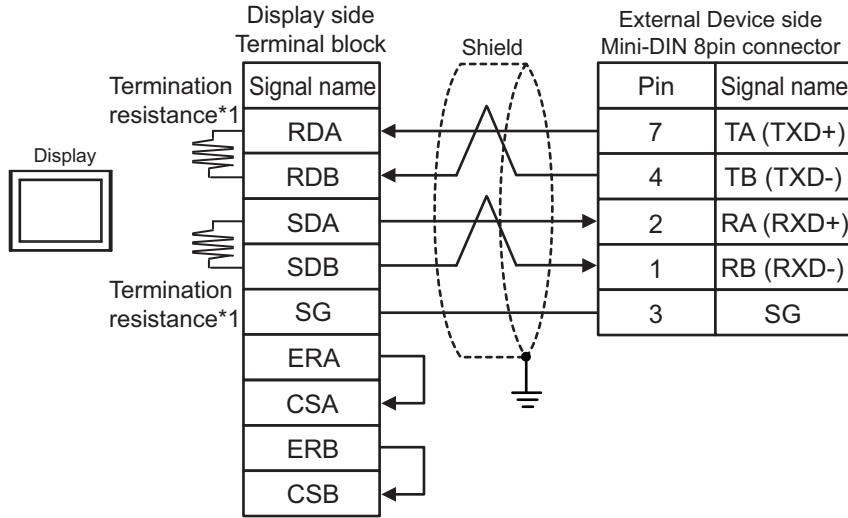

\*1 The resistance in the Display is used as the termination resistance. Set the value of the DIP Switch on the rear of the Display as shown in the table below.

DIP Switch No.	Set Value
1	OFF
2	ON
3	OFF
4	ON

3E)

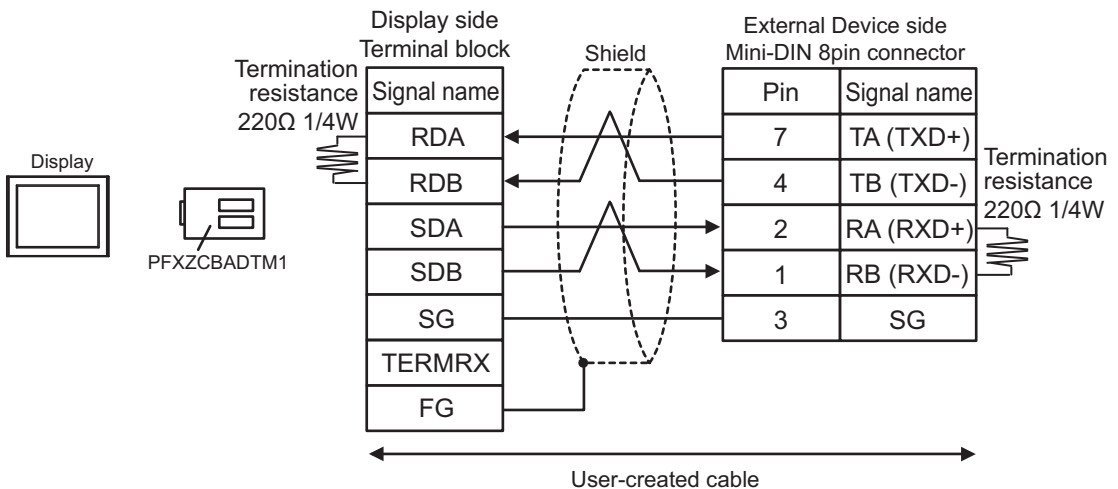

Cable Diagram 4

Display (Connection Port)	Cable		Notes
GP-4*01TM (COM1) GP-Rear Module (COM1)	4A	COM port conversion adapter by Pro-face CA3-ADPCOM-01 + Terminal block conversion adapter by Pro-face CA3-ADPTRM-01 + User-created cable	The cable length must be 15m or less.
	4B	User-created cable	
IPC*1	4C	COM port conversion adapter by Pro-face CA3-ADPCOM-01 + Terminal block conversion adapter by Pro-face CA3-ADPTRM-01 + User-created cable	The cable length must be 15m or less.
	4D	User-created cable	
GP-4106 (COM1) GP-4116T (COM1)	4E	User-created cable	The cable length must be 15m or less.
GP-4107 (COM1) GP-4*03T*2 (COM2) GP-4203T (COM1)	4F	User-created cable	The cable length must be 15m or less.
GP4000*3 (COM2) GP-4201T (COM1) SP5000*4 (COM1/2) SP-5B00 (COM2)	4G	RS-422 Terminal Block Conversion Adapter by Pro-face PFXZCBADTM1*5 + User-created cable	The cable length must be 15m or less.
	4B	User-created cable	
LT-4*01TM (COM1) LT-Rear Module (COM1)	4H	RJ45 RS-485 Cable (5m) by Pro-face PFXZLMCBJR81	The cable length must be 15m or less.
PE-4000B*6 PS5000*6	4I	User-created cable	The cable length must be 15m or less.

\*1 Only the COM port which can communicate by RS-422/485 (2 wire) can be used. (Except PE-4000B, PS5000)  
 ■ IPC COM Port (page 5)

\*2 Except GP-4203T

\*3 All GP4000 models except GP-4100 Series, GP-4\*01TM, GP-Rear Module, GP-4201T and GP-4\*03T

\*4 Except SP-5B00

\*5 When using a Terminal Block Conversion Adapter (CA3-ADPTRM-01) instead of the RS-422 Terminal Block Conversion Adapter, refer to Cable Diagram 4A.

\*6 Only the COM port which can communicate by RS-422/485 (2 wire) can be used.  
 ■ IPC COM Port (page 5)

4A)

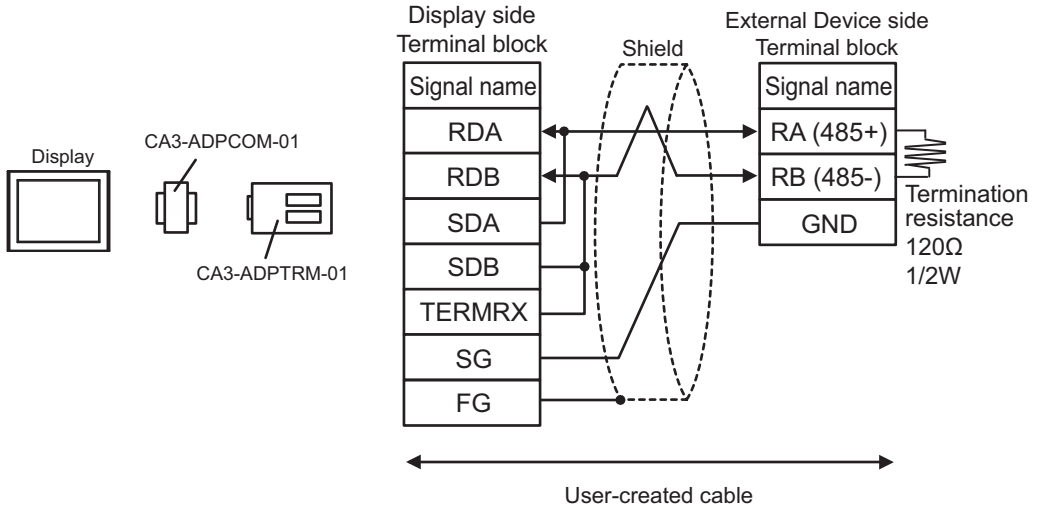

4B)

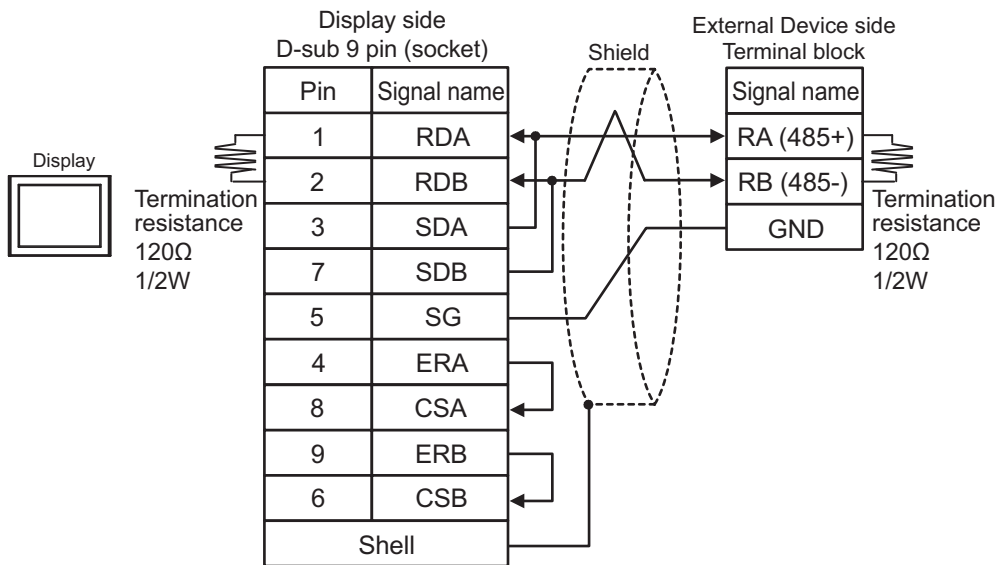

4C)

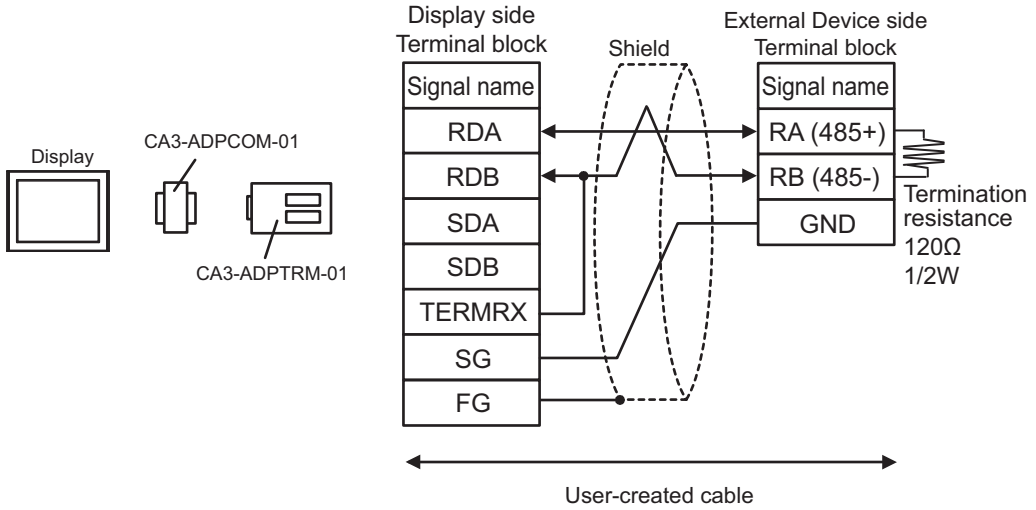

4D)

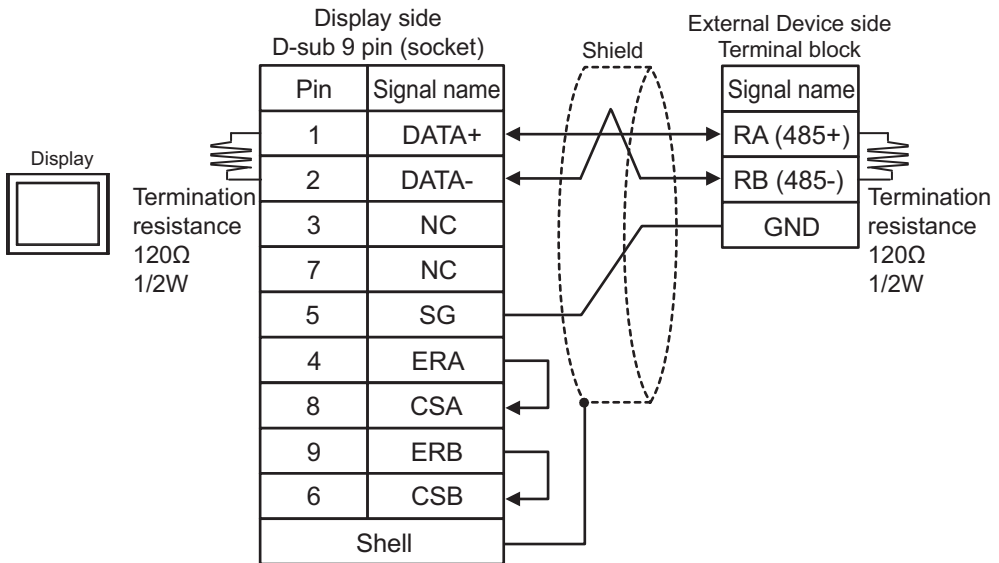

4E)

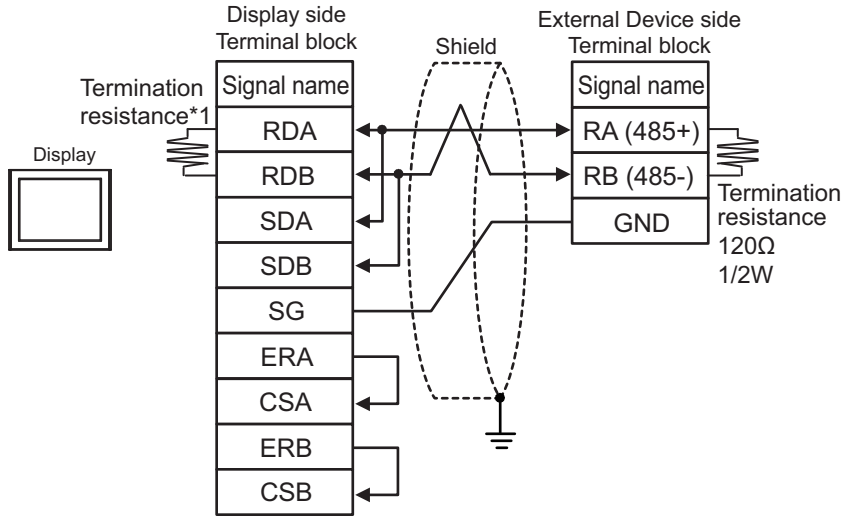

\*1 The resistance in the Display is used as the termination resistance. Set the value of the DIP Switch on the rear of the Display as shown in the table below.

DIP Switch No.	Set Value
1	OFF
2	OFF
3	ON
4	ON

4F)

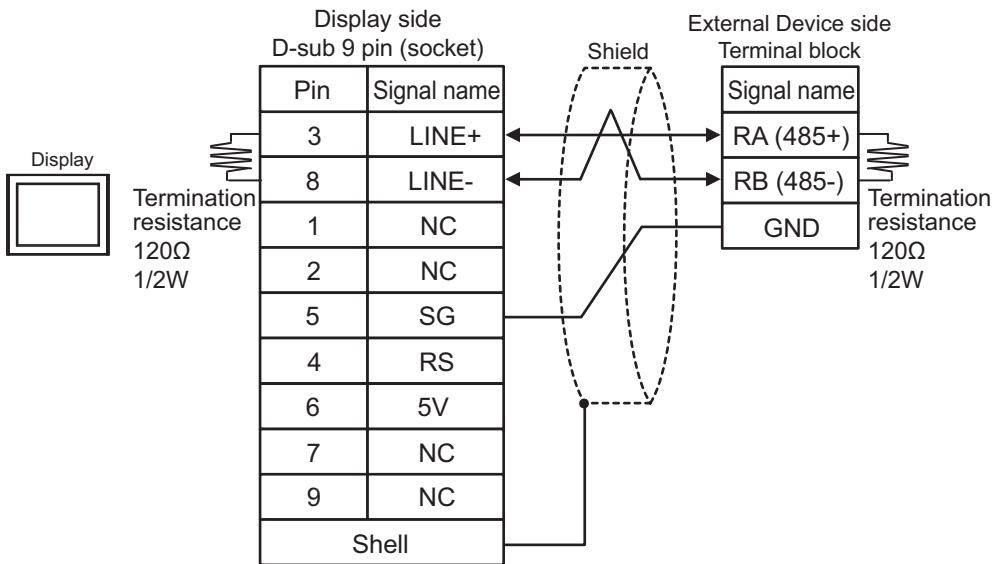

**NOTE**

• In COM on the GP-4107, the SG and FG terminals are isolated.

4G)

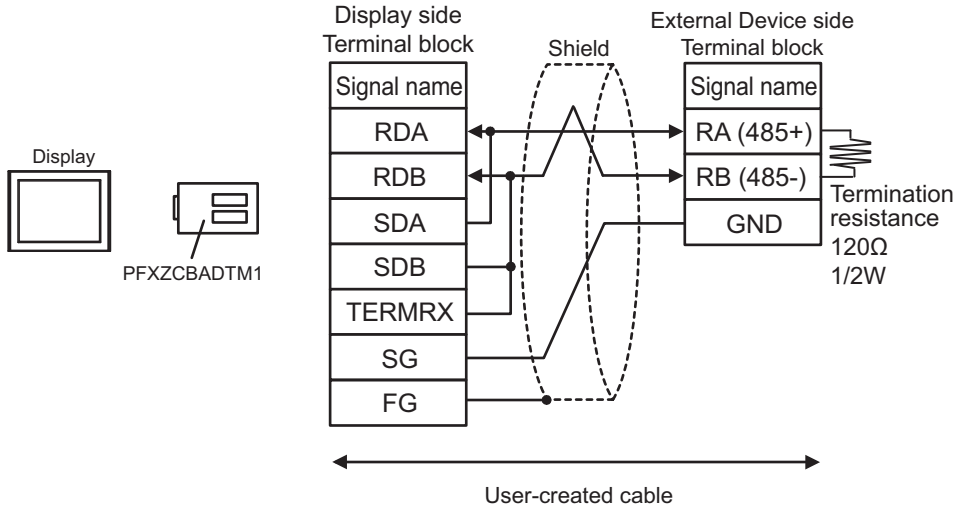

4H)

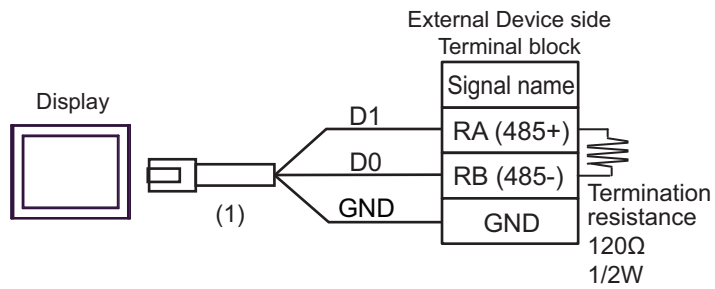

Number	Name	Notes
(1)	RJ45 RS-485 Cable (5m) by Pro-face PFXZLMCBRJ81	

4l)

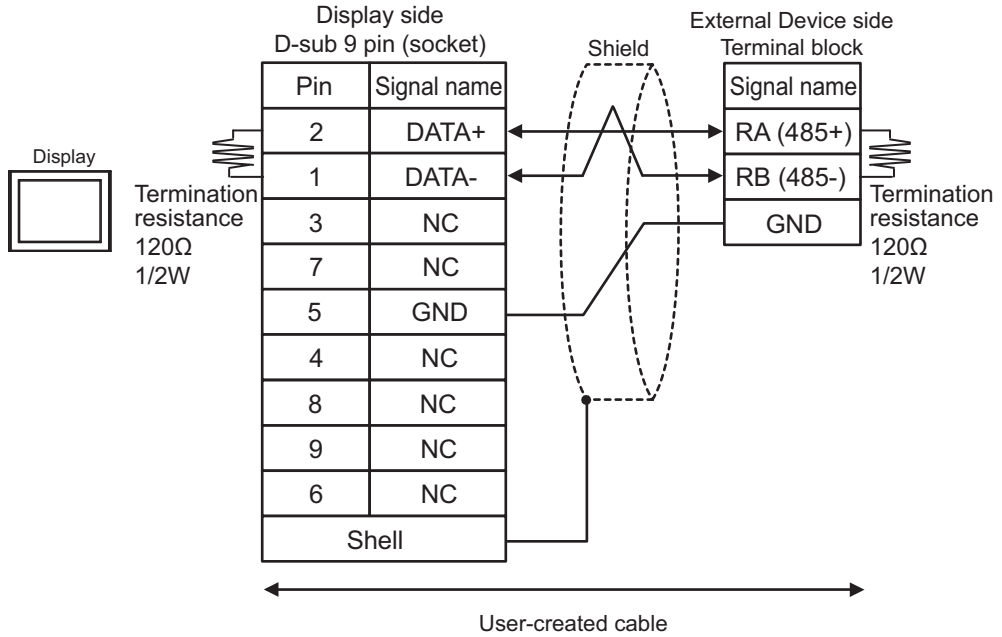







## 6 Supported Device

The range of supported device addresses is shown in the table below. Please note that the actual supported range for devices varies depending on the external device that is used. Please check the actual range in the external device manual.

### 6.1 H1U/H2U Series

 : This address can be specified as system data area.

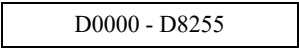
Device	Bit Address	Word Address	32 bits	Remarks
Input Register	X000 - X377	-		
Output Relay	Y000 - Y377	-		
Internal Relay	M0000 - M3071	-		
Special Relay	M8000 - M8255	-		
State Relay	S000 - S999	-		
Timer Contact	T000 - T255	-		
Timer Register	-	T000 - T255		
Counter Contact	C000 - C255	-		
Counter Register	-	C000 - C199		
	-	C200 - C255		*1
Data Register	-	 D0000 - D8255		



\*1 32-bit device

#### NOTE

- Refer to the GP-Pro EX Reference Manual for system data area.  
Cf. GP-Pro EX Reference Manual "LS Area (Direct Access Method Area)"
- Refer to the precautions on manual notation for icons in the table.  
 "Manual Symbols and Terminology"

6.2 H3U Series

 : This address can be specified as system data area.

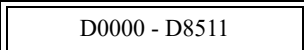
Device	Bit Address	Word Address	32 bits	Remarks
Input Register	X000 - X377	-	<b>[L/H]</b>	
Output Relay	Y000 - Y377	-		
Internal Relay	M0000 - M7679	-		
Special Relay	M8000 - M8511	-		
	SM0000 - SM1023			
State Relay	S0000 - S4095	-		
Timer Contact	T000 - T511	-		
Timer Register	-	T000 - T511		
Counter Contact	C000 - C255	-		
Counter Register	-	C000 - C199		
	-	C200 - C255		*1
Data Register	-	 D0000 - D8511		
Special Register		SD0000 - SD1023		
Extension Register		R00000 - R32767		

\*1 32-bit device

---

**NOTE**

- Refer to the GP-Pro EX Reference Manual for system data area.

Cf. GP-Pro EX Reference Manual "LS Area (Direct Access Method Area)"

- Refer to the precautions on manual notation for icons in the table.

 "Manual Symbols and Terminology"

---

## 7 Device Code and Address Code

Use device code and address code if you select "Device Type & Address" for the address type in Data displays.

Device	Device Name	Device Code (HEX)	Address Code
Timer (Register)	T	0060	Word Address
Counter (Register)	C	0061 <sup>*1</sup>	Word Address
		0062 <sup>*2</sup>	Word Address
Data Register	D	0063	Word Address
Special Register	SD	0064	Word Address <sup>*3</sup>
Extension Register	R	0065	Word Address <sup>*3</sup>

\*1 Device code for C000 to C199

\*2 Device code for C200 to C255

\*3 Supported by H3U series only

## 8 Error Messages

Error messages are displayed on the Display screen as follows: "No.: Device Name: Error Message (Error Occurrence Area)". Each description is shown below.

Item	Description
No.	Error No.
Device Name	Name of the External Device where an error has occurred. Device name is a title of the External Device set with GP-Pro EX. (Initial value [PLC1])
Error Message	Displays messages related to an error that has occurred.
Error Occurrence Area	<p>Displays the IP address or device address of the External Device where an error has occurred, or error codes received from the External Device.</p> <p><b>NOTE</b></p> <ul style="list-style-type: none"> <li>• IP address is displayed as "IP address (Decimal): MAC address (Hex)".</li> <li>• Device address is displayed as "Address: Device address".</li> <li>• Received error codes are displayed as "Decimal [Hex]".</li> </ul>

Display Examples of Error Messages

"RHAA035: PLC1: Error has been responded for device write command (Error Code: 1 [01H])"

**NOTE**

- Refer to your External Device manual for details on received error codes.
- Refer to "Display-related errors" in "Maintenance/Troubleshooting Manual" for details on the error messages common to the driver.