

# PS6000 Series

## User Manual

PS6000-MM01-EN\_02

06/2021

**Pro-face**<sup>™</sup>

by **Schneider** Electric

# Legal Information

The Pro-face brand and any trademarks of Schneider Electric SE and its subsidiaries referred to in this guide are the property of Schneider Electric SE or its subsidiaries. All other brands may be trademarks of their respective owners.

This guide and its content are protected under applicable copyright laws and furnished for informational use only. No part of this guide may be reproduced or transmitted in any form or by any means (electronic, mechanical, photocopying, recording, or otherwise), for any purpose, without the prior written permission of Schneider Electric.

Schneider Electric does not grant any right or license for commercial use of the guide or its content, except for a non-exclusive and personal license to consult it on an "as is" basis. Schneider Electric products and equipment should be installed, operated, serviced, and maintained only by qualified personnel.

As standards, specifications, and designs change from time to time, information contained in this guide may be subject to change without notice.

To the extent permitted by applicable law, no responsibility or liability is assumed by Schneider Electric and its subsidiaries for any errors or omissions in the informational content of this material or consequences arising out of or resulting from the use of the information contained herein.

---

# Table of Contents

Safety Information .....	7
About This Manual.....	8
Document Scope .....	8
Validity Note .....	8
Registered Trademarks .....	8
Related Documents .....	8
Product Related Information .....	8
Overview .....	13
Model Number Configuration .....	13
Model Names .....	14
Package Contents .....	15
Certifications and Standards.....	16
Federal Communication Commission Radio Frequency Interference Statement - For USA.....	17
Hazardous Location Installation - For USA and Canada.....	18
Accessories .....	20
Accessories.....	20
Maintenance Accessories.....	21
Parts Identification and Functions .....	23
Box Module .....	23
Advanced Box .....	23
Standard Box.....	25
Box Module LED Indications .....	26
Display Module.....	27
12-inch and 15-inch.....	27
10-inch Wide, 12-inch Wide, 15-inch Wide, 19-inch Wide, 22-inch Wide .....	27
Display Module LED Indications .....	27
Specifications.....	29
General Specifications .....	29
Electrical Specifications .....	29
Environmental Specifications .....	33
Structural Specifications .....	37
Functional Specifications .....	42
Performance Specifications .....	42
Display Specifications.....	43
Touch Panel.....	44
Clock.....	44
Interface Specifications .....	44
Interfaces .....	44
Interface Connection .....	46
Serial Interface (COM on Box Module).....	48
Dimensions .....	50
Advanced Box .....	50
External Dimensions .....	50
External Dimensions with PCI/PCIe Slots and FAN kit.....	51
Dimensions with Book Mount Adapter (Top) .....	51
Dimensions with Book Mount Adapter (Side).....	52

Dimensions with Flat/Wall Mount Adapter .....	53
Standard Box .....	53
External Dimensions .....	53
Dimensions with Book Mount Adapter (Top) .....	54
Dimensions with Book Mount Adapter (Side) .....	54
Panel Type - Advanced Model .....	55
12-inch Advanced Model .....	55
15-inch Advanced Model .....	57
12-inch Wide Advanced Model .....	59
15-inch Wide Advanced Model .....	60
19-inch Wide Advanced Model .....	61
22-inch Wide Advanced Model .....	63
Panel Type - Standard Model .....	65
12-inch Standard Model .....	65
15-inch Standard Model .....	66
10-inch Wide Standard Model .....	66
12-inch Wide Standard Model .....	67
15-inch Wide Standard Model .....	68
19-inch Wide Standard Model .....	68
22-inch Wide Standard Model .....	69
Installation Fastener .....	69
Installation and Wiring .....	70
Installation Requirements .....	70
Box Module Installation .....	72
Introduction .....	72
Wall Mounting .....	74
Flat Mounting .....	74
Wall mounting when installing PCI/PCIe slot .....	75
Book Mounting .....	76
Panel Type Installation .....	78
Panel Cut Dimensions .....	78
Installation Procedure .....	79
Removal Procedure .....	81
Wiring the Power Supply .....	83
AC/DC Power Cord Preparation .....	83
Connecting the AC Power Cord .....	84
Connecting the DC Power Cord .....	86
Power Supply Precautions .....	87
Grounding .....	89
Storage Installation .....	90
HDD/SSD Installation .....	90
M.2 SSD Installation .....	92
Expansion Slot Installation .....	97
PCI/PCIe Card Installation .....	97
Memory Installation .....	100
DIMM Installation .....	100
Optional Interface Installation .....	102
Common Installation Procedure .....	102
Before Using Serial Interface Options .....	103
RS-232C isolated x 2 .....	105
RS-232C x 4 .....	106

RS-422/485 isolated x 2.....	108
Ethernet (GbE IEEE1588).....	112
Audio (Mic-IN, Line-IN, Line-OUT).....	113
EtherCAT (Controller).....	114
EtherCAT Driver and Firmware Installation.....	115
WiFi/Bluetooth with antennas.....	120
4G Cellular.....	125
16DI/8DO.....	134
USB Type A/Type C Cable Clamp.....	142
Front USB Cover.....	144
FAN Kit.....	145
Maintenance.....	148
Regular Cleaning.....	148
Periodic Check Points.....	148
Replacing the Display Module.....	149
Replacing the Fan Filter.....	151
Replacing the Installation Gasket.....	152
Replacing the Battery and the Backlight.....	153
After-sales Service.....	153
System Function Settings.....	154
Main Features.....	154
Cybersecurity.....	154
At First Startup.....	155
Windows Update.....	156
UEFI BIOS.....	156
UEFI BIOS Setup Menu.....	156
Changing the UEFI BIOS Password.....	157
Launcher.....	157
Starting the Launcher.....	157
Buzzer.....	158
Brightness.....	159
Calibration.....	160
Front USB.....	160
Write Filter.....	161
HORM.....	162
Shell.....	163
Power.....	164
System.....	165
Touch Mode.....	165
System Monitor.....	166
Window Locker.....	166
Cellular.....	167
Edit.....	167
RAID.....	168
RAID Levels.....	168
RAID Configuration.....	168
RAID Setup (System Version 1.1 or later).....	169
RAID Setup (System Version 1.0).....	171
Deleting RAID settings.....	173
System Monitor.....	174
How to Run System Monitor.....	174

---

Node.js and Node-RED Update.....	175
Change Access Rights for Node-RED Related Files .....	175
Editing and Creating Dashboards .....	175
System Monitor API.....	175
TPM.....	175
McAfee Software .....	175
Backup .....	178
System Recovery.....	179
API .....	181

# Safety Information

## Important Information



Read these instructions carefully, and look at the equipment to become familiar with the device before trying to install, operate, service, or maintain it. The following special messages may appear throughout this documentation or on the equipment to warn of potential hazards or to call attention to information that clarifies or simplifies a procedure.



The addition of this symbol to a “Danger” or “Warning” safety label indicates that an electrical hazard exists which will result in personal injury if the instructions are not followed.



This is the safety alert symbol. It is used to alert you to potential personal injury hazards. Obey all safety messages that follow this symbol to avoid possible injury or death.

 <b>DANGER</b>
<b>DANGER</b> indicates a hazardous situation which, if not avoided, <b>will result in</b> death or serious injury.
 <b>WARNING</b>
<b>WARNING</b> indicates a hazardous situation which, if not avoided, <b>could result in</b> death or serious injury.
 <b>CAUTION</b>
<b>CAUTION</b> indicates a hazardous situation which, if not avoided, <b>could result in</b> minor or moderate injury.
<b>NOTICE</b>
<b>NOTICE</b> is used to address practices not related to physical injury.

## Please Note

Electrical equipment should be installed, operated, serviced, and maintained only by qualified personnel. No responsibility is assumed by Schneider Electric for any consequences arising out of the use of this material.

A qualified person is one who has skills and knowledge related to the construction and operation of electrical equipment and its installation, and has received safety training to recognize and avoid the hazards involved.

# About This Manual

## Document Scope

This manual describes the configuration and usage of the PS6000 Series Box Module, Display Module, and Panel Type.

PS6000 Series is designed to operate in an industrial environment.

## Validity Note

This documentation is valid for this product.

The technical characteristics of the device(s) described in the present manual also appear online at [www.pro-face.com](http://www.pro-face.com).

The characteristics that are described in the present document should be the same as those characteristics that appear online. In line with our policy of constant improvement, we may revise content over time to improve clarity and accuracy. If you see a difference between the document and online information, use the online information as your reference.

## Registered Trademarks

Microsoft® and Windows® are registered trademarks of Microsoft Corporation in the United States and/or other countries.

Intel®, Core™ and Celeron® are registered trademarks of Intel Corporation.

Product names used in this manual may be the registered trademarks owned by the respective proprietors.

## Related Documents

You can download the manuals related to this product, such as the software manual, from our website.

<https://www.pro-face.com/trans/en/manual/1085.html>

## Product Related Information

If the equipment is used in a manner not specified by the manufacturer, the protection provided by the equipment may be impaired.



**⚠️ DANGER****HAZARD OF ELECTRIC SHOCK, EXPLOSION, OR ARC FLASH**

- Remove all power from the device before removing any covers or elements of the system, and prior to installing or removing any accessories, hardware, or cables.
- Unplug the power cable from both this product and the power supply.
- Always use a properly rated voltage sensing device to confirm power is off where and when indicated.
- Replace and secure all covers or elements of the system before applying power to this product.
- Use only the specified voltage when operating this product. The DC model is designed to use 24 Vdc, and the AC model is designed to use 100 to 240 Vac. Always check whether your device is DC or AC powered before applying power.
- When using this product in Class I, Division 2, Groups A, B, C, and D hazardous locations, install this product in an enclosure that prevents the operator from touching the back of this product without the use of tools.

**Failure to follow these instructions will result in death or serious injury.**

Critical alarm indicators and system functions require independent and redundant protection hardware and/or mechanical interlocks.

When you cycle power, wait at least 10 seconds after it has been turned off. If this product is restarted too quickly, it may not operate correctly.

In the event the screen cannot be properly read, for example, if the backlight is not functioning, it may be difficult or impossible to identify a function. Functions that may present a hazard if not immediately executed, such as a fuel shut-off, must be provided independently of this product. The machine's control system design must take into account the possibility of the backlight no longer functioning and the operator being unable to control the machine or making mistakes in the control of the machine.

**⚠️ WARNING****LOSS OF CONTROL**

- The designer of any control scheme must consider the potential failure modes of control paths and, for certain critical control functions, provide a means to achieve a safe state during and after a path failure. Examples of critical control functions are emergency stop and overtravel stop, power outage and restart.
- Separate or redundant control paths must be provided for critical control functions.
- System control paths may include communication links. Consideration must be given to the implications of unanticipated transmission delays or failures of the link.
- Observe all accident prevention regulations and local safety guidelines.
- Each implementation of this product must be individually and thoroughly tested for proper operation before being placed into service.
- The machine control system design must take into account the possibility of the backlight no longer functioning and the operator being unable to control the machine, or making errors in the control of the machine.

**Failure to follow these instructions can result in death, serious injury, or equipment damage.**

For additional information, refer to NEMA ICS 1.1 (latest edition), "Safety Guidelines for the Application, Installation, and Maintenance of Solid State Control" and to NEMA ICS 7.1 (latest edition), "Safety Standards for Construction and Guide for Selection, Installation and Operation of Adjustable-Speed Drive Systems" or their equivalent governing your particular location.

**NOTE:** This product is a highly configurable device and is not based on a real-time operating system. Changes to the software and settings of the following must be considered new implementations as discussed in the previous warning messages. Examples of such changes include:

- System BIOS
- Operating System
- Installed hardware
- Installed software

## ▲ WARNING

### UNINTENDED EQUIPMENT OPERATION

- The application of this product requires expertise in the design and programming of control systems. Only persons with such expertise should be allowed to program, install, alter, and apply this product.
- Follow all local and national safety standards.

**Failure to follow these instructions can result in death, serious injury, or equipment damage.**

## ▲ WARNING

### UNINTENDED EQUIPMENT OPERATION

- Do not use this product as the only means of control for critical system functions such as motor start/stop or power control.
- Do not use this equipment as the only notification device for critical alarms, such as device overheating or overcurrent.
- Use only the software provided with this product. If you use other software, please confirm the operation and safety before use.

**Failure to follow these instructions can result in death, serious injury, or equipment damage.**

The following characteristics are specific to the LCD panel and are considered normal behavior:

- LCD screen may show unevenness in the brightness of certain images or may appear different when seen from outside the specified viewing angle. Extended shadows, or crosstalk may also appear on the sides of screen images.
- LCD screen pixels may contain black and white colored spots and color display may seem to have changed.
- When experiencing vibrations within a certain frequency range and vibration acceleration is above what is acceptable, the LCD screen may partially turn white. Once the vibration condition ends, the whitening of the screen is resolved.
- When the same image is displayed on the screen for a long period, an afterimage may appear when the image is changed.
- The panel brightness may decrease when used for a long time in an environment continuously filled with inert gas. To prevent deterioration of panel brightness, regularly ventilate the panel. For more information, please contact customer support.

<https://www.pro-face.com/trans/en/manual/1015.html>

**NOTE:** Change the screen image periodically and try not to display the same image for a long period of time.

**▲ WARNING****SERIOUS EYE AND SKIN INJURY**

The liquid in the LCD panel contains an irritant:

- Avoid direct skin contact with the liquid.
- Wear gloves when you handle a broken or leaking unit.
- Do not use sharp objects or tools in the vicinity of the LCD panel.
- Handle the LCD panel carefully to prevent puncture, bursting, or cracking of the panel material.
- If the panel is damaged and any liquid comes in contact with your skin, immediately rinse the area with running water for at least 15 minutes. If the liquid gets in your eyes, immediately rinse your eyes with running water for at least 15 minutes and consult a doctor.

**Failure to follow these instructions can result in death, serious injury, or equipment damage.**

**Precautions on using models with projected capacitive touch panel**

Models with a projected capacitive touch panel may operate abnormally when the display surface is wet.

**▲ WARNING****LOSS OF CONTROL**

- Do not touch the touch panel area during operating system startup.
- Do not operate when the touch panel surface is wet.
- If the touch panel surface is wet, remove any excess water with a soft cloth before operation.

**Failure to follow these instructions can result in death, serious injury, or equipment damage.**

**NOTE:**

- If **Touch Mode** is set to **Water detection mode**, when an abnormal touch (such as water) occurs, touch is disabled for a few seconds to avoid accidental touch. Normal touch operation recovers a few seconds after the abnormal touch condition is removed. For information about Touch Mode, refer to [Touch Mode](#), page 165.
- While the system is starting up, as the touch panel initial values are being checked, do not touch the touch panel area.

**NOTICE****EQUIPMENT DAMAGE**

- Do not press on the display of this product with excessive force or with a hard object.
- Do not press on the touch panel with a pointed object, such as the tip of a mechanical pencil or a screwdriver.
- Handle this product carefully to prevent puncture, bursting, or cracking of the panel material.

**Failure to follow these instructions can result in equipment damage.**

Compared to conventional analog resistive film, projected capacitive touch panels have higher transmittance and lighter touch operation, as well as supporting multi-touch. As it is able to detect weak changes in capacitance, projected capacitive touch panels are susceptible to environmental noise.

While our products have been optimized for industrial environmental noise and conform to CE marking, our products cannot support all environmental noise.

Please consider the following in the installation environment to avoid touch malfunction.

Example:

To reduce the noise voltage of the enclosure of the equipment housing this product:

- Implement noise countermeasures in the equipment. For example, install a noise filter on the inverter, servo amplifier, or other equipment. Refer to the manufacturer's instruction manual.
- Attach a ground wire noise filter to the FG connection of equipment.
- Connect the enclosure for the equipment to the building. For example, connect to the concrete or steel reinforcement parts of the building.

**NOTE:** If there is a lot of environmental noise, because the noise filter for the touch panel controller has to run, touch response may become slow.

# Overview

## What's in This Chapter

Model Number Configuration..... 13  
 Model Names..... 14  
 Package Contents..... 15  
 Certifications and Standards ..... 16  
 Federal Communication Commission Radio Frequency Interference  
 Statement - For USA ..... 17  
 Hazardous Location Installation - For USA and Canada ..... 18

## Model Number Configuration

The following describes the configuration of model numbers.

Digit	Category	Number	Description
1–5	(Prefix)	PFXP6	
6	CPU (Base unit)	7	Core i7 (Advanced Box)
		5	Core i5 (Advanced Box)
		C	Celeron (Advanced Box)
		3	Core i3 (Standard Box)
7	Display Module	B	None (Box Module)
		6	12-inch
		7	15-inch
		D	10-inch Wide*1
		E	12-inch Wide
		F	15-inch Wide
		G	19-inch Wide
		A	22-inch Wide
8	Power supply	D	24 Vdc for Advanced Box
		A	100–240 Vac for Advanced Box
		1	24 Vdc for Standard Box
		2	100–240 Vac for Standard Box
9	Slots	0	None
		M	PCI x 1 + PCIe x 1
		E	PCIe x 2
		P	PCI x 2
10	Fan	N	None
		F	With FAN kit
11	Main storage	0	None
		1	M.2 SSD 128 GB (Standard Endurance)
		2	M.2 SSD 128 GB (High Endurance)
		3	M.2 SSD 256 GB (High Endurance)
		4	M.2 SSD 512 GB (High Endurance)
		5	SSD 128 GB (High Endurance)
		6	SSD 256 GB (High Endurance)
		7	SSD 512 GB (High Endurance)
8	HDD 1 TB		
12	Secondary storage	0	None
		5	SSD 128 GB (High Endurance)
		6	SSD 256 GB (High Endurance)
		7	SSD 512 GB (High Endurance)
		8	HDD 1 TB
13	Memory	4	DIMM 4 GB (4 GB x 1) (Celeron only)
		8	DIMM 8 GB (4 GB x 2)
		A	DIMM 16 GB (8 GB x 2)
		B	DIMM 32 GB (16 GB x 2) (i7, i5 and i3 only)
14	Options	N	None

Digit	Category	Number	Description
		B	RS-232C isolated x 2 <sup>2</sup>
		C	RS-232C x 4
		D	RS-422/485 isolated x 2 <sup>2</sup>
		E	Ethernet (GbE IEEE1588) x 1
		F	Audio (Mic-IN, Line-IN, Line-OUT)
		G	EtherCAT (Controller)
15	Operating system	N	None
		C	Windows® 10 IoT Enterprise 2019 LTSC (64bit) for Celeron
		3	Windows® 10 IoT Enterprise 2019 LTSC (64bit) for Core i3/i5
		7	Windows® 10 IoT Enterprise 2019 LTSC (64bit) for Core i7
16	Software	N	None
		B	BLUE license key code
		R	Pro-face Remote HMI Server license key code
		C	BLUE Open Studio Runtime 1.5 K license key code
		D	BLUE Open Studio Runtime 4 K license key code
		F	BLUE Open Studio Runtime 32 K license key code
		E	BLUE Open Studio Runtime 64 K license key code
17	Kitting Service	0	None
		P	Software Pre-installation Service
18	(Reserved)	0	None

\*1 You can only connect to Standard Box.

\*2 When using Box Module by itself, be careful when mounting it to a panel. Refer to Box Module Installation, page 72 and Optional Interface Installation, page 102.

**NOTE:** All instructions applicable to the enclosed product and all safety precautions must be observed.

## Model Names

Box Module and Panel Type are referred to as follows.

Panel Type is an all-in-one model in which the Box Module and Display Module are already connected.

	Box Module	Panel Type
Core i7	Advanced Box	●●-inch/●●-inch Wide Advanced Model
Core i5		
Celeron		
Core i3	Standard Box	●●-inch/●●-inch Wide Standard Model

## Global Code

A global code is assigned to every Pro-face product as a universal model number. For more information on product models and their matching global codes, please refer to the following URL.

<https://www.pro-face.com/trans/en/manual/1003.html>

## Package Contents

This product has been carefully packed with special attention to quality. However, should you find anything damaged or missing, please contact customer support immediately.

### Box Module

Verify all items listed here are present in your package:

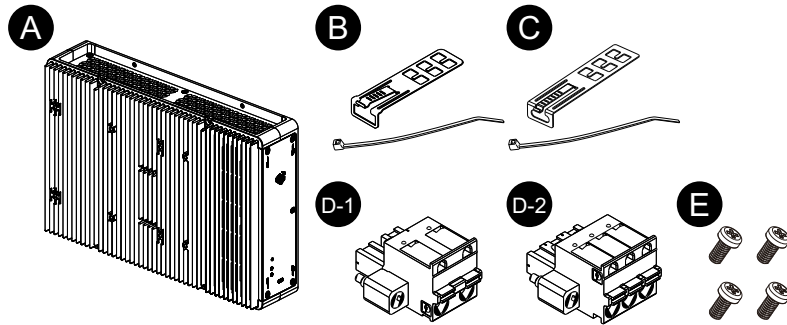

- A. PS6000 Series Box Module x 1
- B. USB cable clamp (Type A) x 4 sets (4 clips and 4 ties)
- C. USB cable clamp (Type C) x 1 set (1 clip and 1 tie)
- D. Power connector x 1 (D-1 for AC, D-2 for DC)
- E. M4 screws x 4 (to install the Display Module)
- F. Warning/Caution Information x 1

### Panel Type

Verify all items listed here are present in your package:

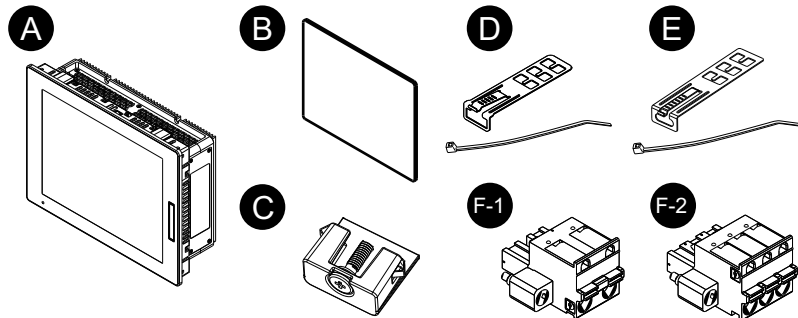

- A. PS6000 Series Panel Type x 1
- B. Installation gasket (attached to this product) x 1
- C. Installation fasteners (to install on a panel):
  - 4 pieces (for 12-inch, 10-inch Wide and 12-inch Wide models)
  - 8 pieces (for 15-inch, 15-inch Wide, 19-inch Wide and 22-inch Wide models)
- D. USB cable clamp (Type A) x 4 sets (4 clips and 4 ties)
- E. USB cable clamp (Type C) x 1 set (1 clip and 1 tie)
- F. Power connector x 1 (F-1 for AC, F-2 for DC)
- G. Warning/Caution Information x 1

## Revision and QR Code for Manual

You can identify the product version (PV) and the software version (SV) from the product label.

You can also check the contents of this manual by using the QR code on the product label. Confirm the location of the QR code below and refer to the manual.

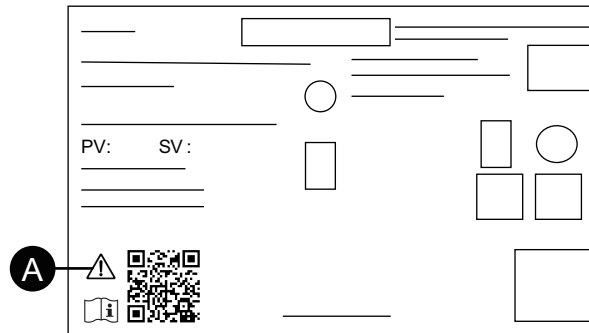

- A. This mark indicates that you can refer to this manual by using the QR code, and that you must use copper wire rated for 75 °C (167 °F) or higher. Refer to *Wiring the Power Supply*, page 83.

## Certifications and Standards

The certifications and standards listed below may include those that are not yet acquired. Please check the product marking and the following URL for the latest acquisition status.

<https://www.pro-face.com/trans/en/manual/1002.html>

### Agency Certifications

#### All models

- Underwriters Laboratories Inc., UL 61010-2-201 and CSA C22.2 N°61010-2-201, for Industrial Control Equipment used in Ordinary Locations
- Underwriters Laboratories Inc., UL 121201 and CSA C22.2 N°213, for Industrial Control Equipment used in Class I, Division 2 Hazardous (Classified) Locations

#### Only DC models

- IECEx / ATEX for use in zone 2 gas/ zone 22 dust
- Det Norske Veritas - Germanischer Lloyd (DNV-GL)\*1

\*1 All models with HDD, and 22-inch Wide models with PCI/PCIe slots attached, are not DNV-GL certified.

### Compliance Standards

Europe:

CE

- Directive 2014/35/EU (Low Voltage)
- Directive 2014/30/EU (EMC)
- Directive 2014/34/EU (ATEX)

Australia:

- RCM

Korea:

- KC



## Hazardous Substances

This product is designed to be compliant with the following environmental regulations, even if the product may not fall directly in the scope of the regulation:

- RoHS, Directive 2011/65/EU and 2015/863/EU
- RoHS China, Standard GB/T 26572
- REACH regulation EC 1907/2006

## End of Life (WEEE)

The product contains electronic boards. It must be disposed of in specific treatment channels. The product contains cells and/or storage batteries which must be collected and processed separately when they have run out and at the end of product life (Directive 2012/19/EU).

Refer to *Maintenance*, page 148 when extracting cells and batteries from the product. These batteries do not contain a weight percentage of heavy metals over the threshold notified by European Directive 2006/66/EC.

## KC Markings

기종별	사용자안내문
A급 기기 (업무용 방송통신기자재)	이 기기는 업무용(A급) 전자파적합기기로서 판매자 또는 사용자는 이 점을 주의하시기 바라며, 가정외의 지역에서 사용하는 것을 목적으로 합니다.

## Federal Communication Commission Radio Frequency Interference Statement - For USA

### FCC Radio Interference Information

This product has been tested and found to comply with the Federal Communications Commission (FCC) limits for a Class A digital device, pursuant to Part 15 of the FCC Rules. These limits are designed to provide reasonable protection against harmful interference in a commercial, industrial or business environment. This product generates, uses, and can radiate radio frequency energy and, if not installed and used in accordance with the instructions, may cause or be subject to interference with radio communications. To minimize the possibility of electromagnetic interference in your application, observe the following two rules:

- Install and operate this product in such a manner that it does not radiate sufficient electromagnetic energy to cause interference in nearby devices.
- Install and test this product to ensure that the electromagnetic energy generated by nearby devices does not interfere with the operation of this product.
- Changes or modifications not expressly approved by the party responsible for compliance could void the user's authority to operate this product.

**⚠ WARNING****ELECTROMAGNETIC / RADIO INTERFERENCE**

Electromagnetic radiation may disrupt the operation of this product leading to unintended equipment operation. If electromagnetic interference is detected:

- Increase the distance between this product and the interfering equipment.
- Reorient this product and the interfering equipment.
- Reroute power and communication lines to this product and the interfering equipment.
- Connect this product and the interfering equipment to different power supplies.
- Always use shielded cables when connecting this product to a peripheral device or another computer.

**Failure to follow these instructions can result in death, serious injury, or equipment damage.**

## Hazardous Location Installation - For USA and Canada

### General

This product is suitable for use in Class I, Division 2, Groups A, B, C, and D hazardous locations or in non-hazardous locations. Before installing or using this product, confirm that the Hazardous Location certification appears on the product labeling.

**NOTE:** Some products are not yet rated as suitable for use in hazardous locations. Always use your product in conformance with the product labeling and this manual.

**⚡⚠ DANGER****HAZARD OF ELECTRIC SHOCK, EXPLOSION, OR ARC FLASH**

- Remove all power from the device before removing any covers or elements of the system, and prior to installing or removing any accessories, hardware, or cables.
- Unplug the power cable from both this product and the power supply.
- Always use a properly rated voltage sensing device to confirm power is off where and when indicated.
- Replace and secure all covers or elements of the system before applying power to this product.
- Use only the specified voltage when operating this product. The DC model is designed to use 24 Vdc, and the AC model is designed to use 100 to 240 Vac. Always check whether your device is DC or AC powered before applying power.

**Failure to follow these instructions will result in death or serious injury.**

## ▲ WARNING

### EXPLOSION HAZARD

- Do not use this product in hazardous environments or locations other than Class I, Division 2, Groups A, B, C, and D.
- Substitution of any components may impair suitability for Class I, Division 2.
- Always confirm the UL 121201 or CSA C22.2 N°213 hazardous location rating of your device before installing or using it in a hazardous location.
- To apply or remove the supply power from this product installed in a Class I, Division 2 hazardous location, you must either: A) Use a switch located outside the hazardous environment, or B) Use a switch certified for Class I, Division 1 operation inside the hazardous area.
- Do not connect or disconnect equipment unless power has been switched off or the area is known to be non-hazardous. This applies to all connections including power, ground, serial, parallel, and network connections.
- Do not install any components, equipment, or accessories manufactured by us or by OEM unless these have also been qualified as suitable for use in Class I, Division 2, Groups A, B, C, and D locations.
- Never use unshielded/ungrounded cables in hazardous locations.
- Use only non-incendive USB devices.
- Do not attempt to install, operate, modify, maintain, service, or otherwise alter this product except as permitted in this manual. Unpermitted actions may impair the suitability of this product for Class I, Division 2 operation.

**Failure to follow these instructions can result in death, serious injury, or equipment damage.**

Make sure that this product is properly rated for the location. If the intended location does not presently have a Class, Division and Group rating, then users should consult the appropriate authorities having jurisdiction in order to determine the correct rating for that hazardous location.

## Operation and Maintenance

The systems have been designed for compliance with relevant spark ignition tests.

## ▲ WARNING

### EXPLOSION HAZARD

In addition to the other instructions in this manual, observe the following rules when installing this product in a hazardous location:

- Wire the equipment in accordance with the National Electrical Code article 501.10 (B) for Class I, Division 2 hazardous locations.
- Install this product in an enclosure suitable for the specific application.

**Failure to follow these instructions can result in death, serious injury, or equipment damage.**

**NOTE:** IP65F, IP66F and IP67F are not part of UL certification.

# Accessories

## What's in This Chapter

Accessories .....	20
Maintenance Accessories .....	21

## Accessories

Product name	Product number
<b>Interfaces</b>	
RS-232C isolated x 2	PFXYP6MPR23P2
RS-232C x 4	PFXYP6MPR23P4
RS-422/485 isolated x 2	PFXYP6MPR42P2
Ethernet (GbE IEEE1588)	PFXYP6MPETH
Audio (Mic-IN, Line-IN, Line-OUT)	PFXYP6MPAU
EtherCAT (Controller)	PFXYP6MPECAT
16DI/8DO*1	PFXYP6MPX16Y8
4G Cellular for US	PFXYP6MP4GU
4G Cellular for EU, Asia, Japan	PFXYP6MP4GE
WiFi/Bluetooth with antennas	PFXYP6MPWF
<b>Storage</b>	
M.2 SSD 128 GB (Standard Endurance)	PFXYP6M2128L
M.2 SSD 128 GB (High Endurance)	PFXYP6M2128
M.2 SSD 256 GB (High Endurance)	PFXYP6M2256
M.2 SSD 512 GB (High Endurance)	PFXYP6M2512
SSD 128 GB (High Endurance)	PFXYP6SSD128
SSD 256 GB (High Endurance)	PFXYP6SSD256
SSD 512 GB (High Endurance)	PFXYP6SSD512
HDD 1 TB	PFXYP6HDD1T
<b>Memory</b>	
DIMM 4 GB	PFXYP6DM4
DIMM 8 GB	PFXYP6DM8
DIMM 16 GB	PFXYP6DM16
<b>Cables</b>	
WiFi/Bluetooth extended antenna cable 3 m (2 pieces)	PFXYP6CBWF3M
4G Cellular extended antenna cable 3 m (2 pieces)	PFXYP6CB4G3M
<b>Adapters</b>	
Book mount adapter (Advanced Box) (2 pieces for side mounting + 2 pieces for top mounting)	PFXYP6ADBMA
Book mount adapter (Standard Box) (2 pieces for side mounting + 2 pieces for top mounting)	PFXYP6ADBMS
Flat/wall mount adapter (2 pieces, for Advanced Box when the PCI/PCIe slot is connected)	PFXYP6ADFMA
Panel cutout adapter for SP-5700W (15" Wide)*2	PFXZHAT7W1
Panel cutout adapter for SP-5800W (19" Wide)*2	PFXZHAT8W1
Panel cutout adapter for PS-5500W (10" Wide)*2	PFXZPAT5W1

Product name	Product number
Panel cutout adapter for PS-5600W (12" Wide) <sup>*2</sup>	PFXZPAT6W1
Panel cutout adapter for PS-5700W (15" Wide) <sup>*2</sup>	PFXZPAT7W1
Panel cutout adapter for PS-5800W (19" Wide) <sup>*2</sup>	PFXZPAT8W1
Panel cutout adapter for PS-5900W (22" Wide) <sup>*2</sup>	PFXZPAT9W1
<b>Screen sheets</b>	
Anti-glare sheet for 10" Wide (5 sheets/set)	PFXZCAG5W1
Anti-glare sheet for 12" Wide (5 sheets/set)	PFXZCAG6W1
Anti-glare sheet for 15" Wide (5 sheets/set)	PFXZCAG7W1
Anti-glare sheet for 19" Wide (5 sheets/set)	PFXZCAG8W1
Anti-glare sheet for 22" Wide (5 sheets/set)	PFXZCAG9W1
Screen protection sheet for 12" (5 sheets/set)	CA7-DFS12-01
Screen protection sheet for 15" (5 sheets/set)	CA3-DFS15-01
<b>Others</b>	
M.2 cooling kit for Advanced Box <sup>*3</sup>	PFXYP6HSM2A
M.2 cooling kit for Standard Box <sup>*4</sup>	PFXYP6HSM2S
McAfee license	PFXYP6LSMCA
Recovery USB for Windows 10	PFXYP6RUSW10
USB Clamp Type A (5 pieces/set)	PFXZCCLUSA
USB Clamp Type C (5 pieces/set)	PFXYP6CLUSC
FAN kit with filter (5 pieces/set) <sup>*5</sup>	PFXYP6FAN
Enhanced front USB cover (with screw) (5 pieces/set) <sup>*6</sup>	PFXZCDCVUS1

<sup>\*1</sup> When the 16DI/8DO optional interface is installed on the product, it does not comply with UL certification.

<sup>\*2</sup> The range for the allowable panel thickness varies depending on the panel cut adapter. For information, refer to the panel cut adapter instruction manual.

<sup>\*3</sup> Required when installing M.2 SSD. However, it is not required when the FAN kit is installed.

<sup>\*4</sup> Required when installing M.2 SSD.

<sup>\*5</sup> Supported by Advanced Box only.

<sup>\*6</sup> Supported by 12-inch and 15-inch models only.

## Maintenance Accessories

Product name	Product number
<b>Display Module</b>	
12-inch Display Module	PFXDM6600TM <sup>*1</sup>
15-inch Display Module	PFXDM6700TM <sup>*1</sup>
10-inch Wide Display Module	PFXDM6500WC <sup>*1</sup>
12-inch Wide Display Module	PFXDM6600WC <sup>*1</sup>
15-inch Wide Display Module	PFXDM6700WC <sup>*1</sup>
19-inch Wide Display Module	PFXDM6800WC <sup>*1</sup>
22-inch Wide Display Module	PFXDM6900WC <sup>*1</sup>
<b>Installation gaskets</b>	

<b>Product name</b>	<b>Product number</b>
Installation gasket for 12" (1/set)	PFXZCDWG121
Installation gasket for 15" (1/set)	PFXZCDWG151
Installation gasket for 10" Wide (1/set)	PFXZCDWG102
Installation gasket for 12" Wide (1/set)	PFXZCDWG122
Installation gasket for 15" Wide (1/set)	PFXZCHWG154
Installation gasket for 19" Wide (1/set)	PFXZCWG8W1
Installation gasket for 22" Wide (1/set)	PFXZCWG9W1
Installation fastener (4 pieces/set)	PFXZCAF1
Power connector (DC) (5 pieces/set)	CA7-ACCNL-01
Power connector (AC) (5 pieces/set)	PFXZCCNAC1

\*1 Includes models ending with additional characters.

# Parts Identification and Functions

## What's in This Chapter

Box Module.....	23
Display Module .....	27

## Box Module

### Advanced Box

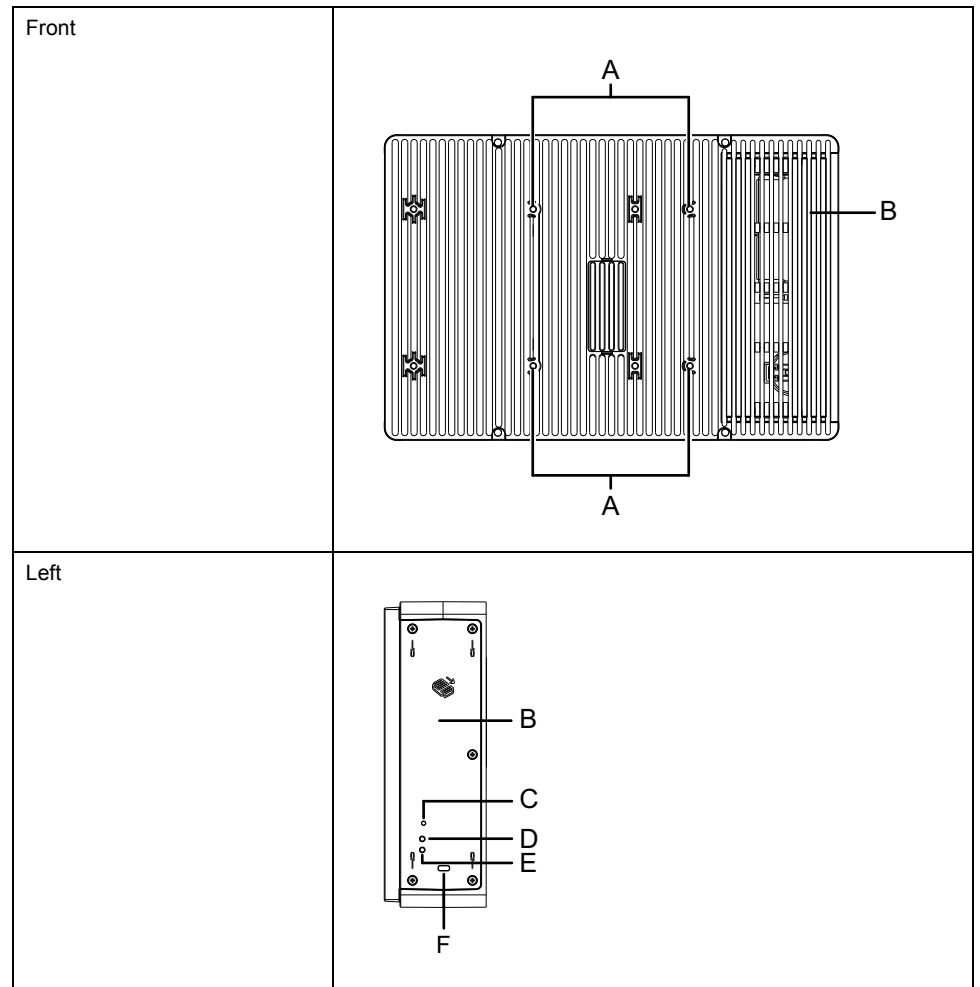

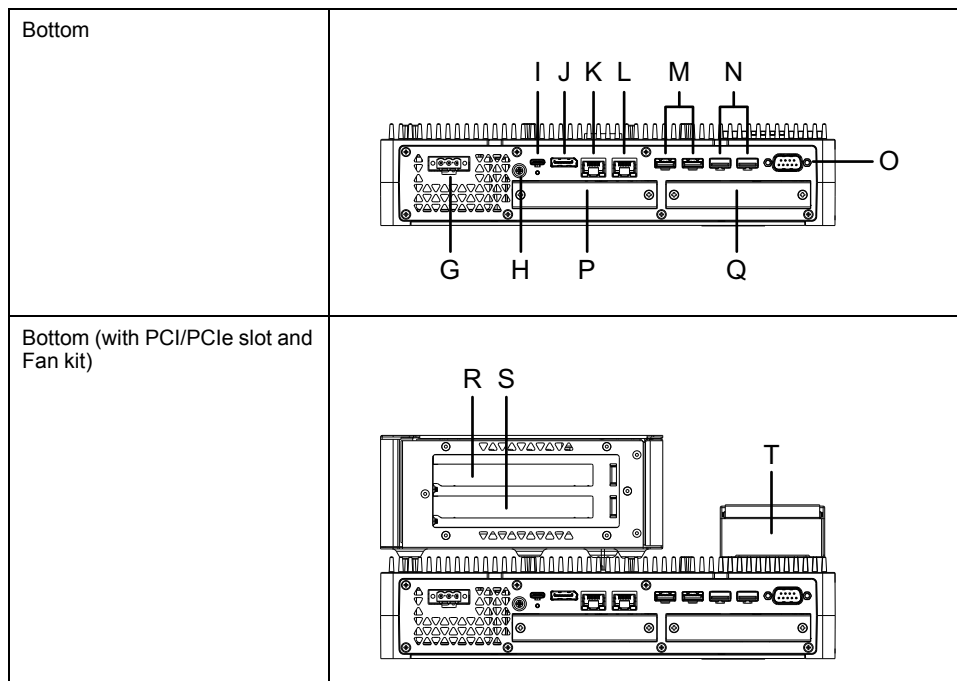

- |   |                                       |
|---|---------------------------------------|
| A. VESA mount screw hole <sup>*1</sup>  | K. Ethernet 1                         |
| B. Maintenance hatch                    | L. Ethernet 2                         |
| C. Power button                         | M. USB 3.0 (Type A) <sup>*3</sup>     |
| D. Storage access LED                   | N. USB 2.0 (Type A) <sup>*3</sup>     |
| E. Power LED                            | O. COM (RS-232C, not isolated)        |
| F. Security lock slot <sup>*2</sup>     | P. Optional interface slot 1          |
| G. Power connector                      | Q. Optional interface slot 2          |
| H. PE terminal (used for AC model only) | R. PCI/PCIe card slot 1 <sup>*4</sup> |
| I. USB 3.0 (Type C)                     | S. PCI/PCIe card slot 2 <sup>*4</sup> |
| J. DisplayPort                          | T. FAN kit                            |

<sup>\*1</sup> This product can be mounted to commercially available monitor arms that comply with the VESA standard (100 x 100 mm). Use four M4 screws (valid screw depth: 8 mm [0.31 in]). The necessary torque is 0.7 to 0.8 N•m (6.2 to 7.1 lb-in). VESA mounting is not UL certified. VESA mounting is not possible when the PCI/PCIe slot is installed.

<sup>\*2</sup> Only Kensington lock supported. Slot size 3 x 7 mm (0.12 x 0.28 in).

<sup>\*3</sup> USB storage devices that support USB 3.0 are recommended. Use the USB 3.0 port to connect the storage devices.

<sup>\*4</sup> For PCI/PCIe slot configuration, refer to Expansion Slot Installation, page 97.



### Standard Box

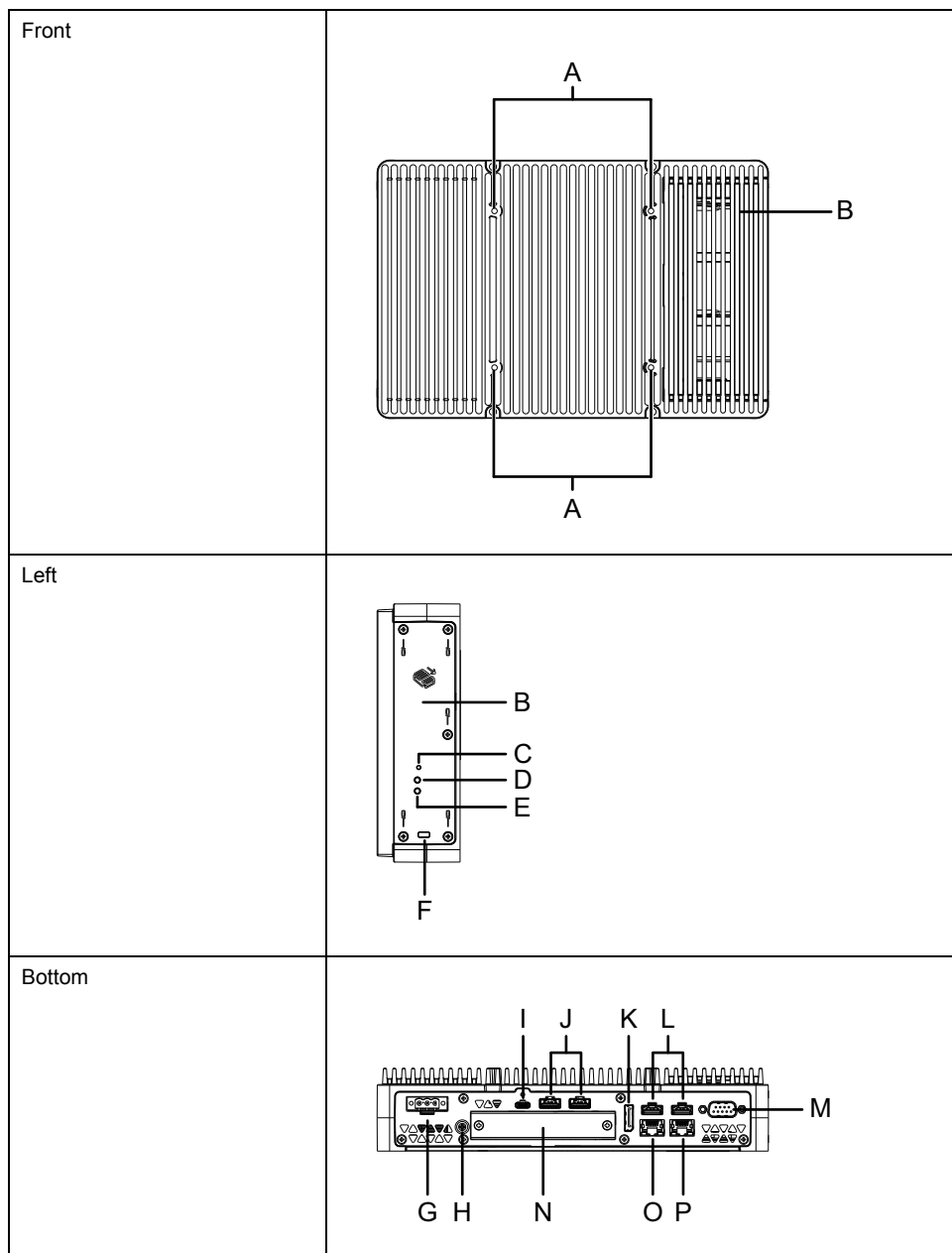

- A. VESA mount screw hole\*<sup>1</sup>
- B. Maintenance hatch
- C. Power button
- D. Storage access LED
- E. Power LED
- F. Security lock slot\*<sup>2</sup>
- G. Power connector
- H. PE terminal (used for AC model only)
- I. USB 3.0 (Type C)
- J. USB 3.0 (Type A)\*<sup>3</sup>
- K. DisplayPort
- L. USB 2.0 (Type A)\*<sup>3</sup>
- M. COM (RS-232C, not isolated)
- N. Optional interface slot
- O. Ethernet 1
- P. Ethernet 2

\*<sup>1</sup> This product can be mounted to commercially available monitor arms that comply with the VESA standard (100 x 100 mm). Use four M4 screws (valid screw depth: 8 mm [0.31 in]). The necessary torque is 0.7 to 0.8 N•m (6.2 to 7.1 lb-in). VESA mounting is not UL certified.

\*<sup>2</sup> Only Kensington lock supported. Slot size 3 x 7 mm (0.12 x 0.28 in).

\*<sup>3</sup> USB storage devices that support USB 3.0 are recommended. Use the USB 3.0 port to connect the storage devices.

## Box Module LED Indications

### Power LED

Color	State	Description
Green	ON	S0 (in operation)
Orange	ON	S3
	Flashing	System is starting up.
Red	ON	S4, S4 (hybrid shutdown)*1, S5
-	OFF	G3 (power is off)

\*1 S4 (hybrid shutdown) is S5 when Windows® fast startup is enabled

### Wake-up Events

The following is a table showing the statuses that are set to the normal startup (S0) state when each action is executed.

ACPI state	Power state	Power up	Power button is ON	Wake on LAN	Touch input	USB equipment*1
S3	Sleep	-	✓	✓	✓	✓
S4	Hibernate	-	✓	✓	-	-
S4 (hybrid shutdown)	Hibernate	-	✓	-	-	-
S5	Soft off	-	✓	✓	-	-
G3	Mechanical off	✓	-	-	-	-

\*1 Limited to USB devices that support the remote wake-up function.

**NOTE:** If you turn on the power when G3 is set, it directly enters state S0.

### Storage Access LED

Color	State	Description
Green	ON	Storage is being accessed.
-	OFF	Storage is not accessed.

# Display Module

## 12-inch and 15-inch

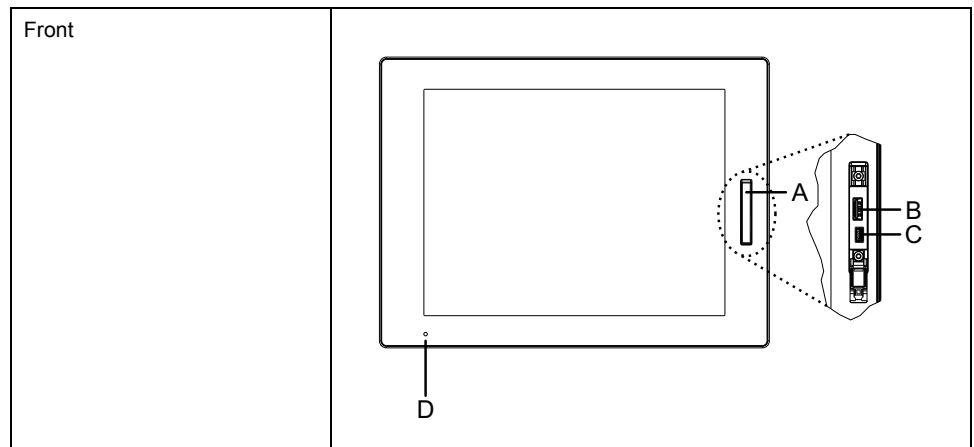

- A. Front USB cover
- B. USB 2.0 (Type A)\*<sup>1</sup>
- C. USB 2.0 (micro-B) (this interface is unavailable.)
- D. Status LED

\*<sup>1</sup> By default, the front USB is disabled. To enable, set in the Launcher, page 157.

## 10-inch Wide, 12-inch Wide, 15-inch Wide, 19-inch Wide, 22-inch Wide

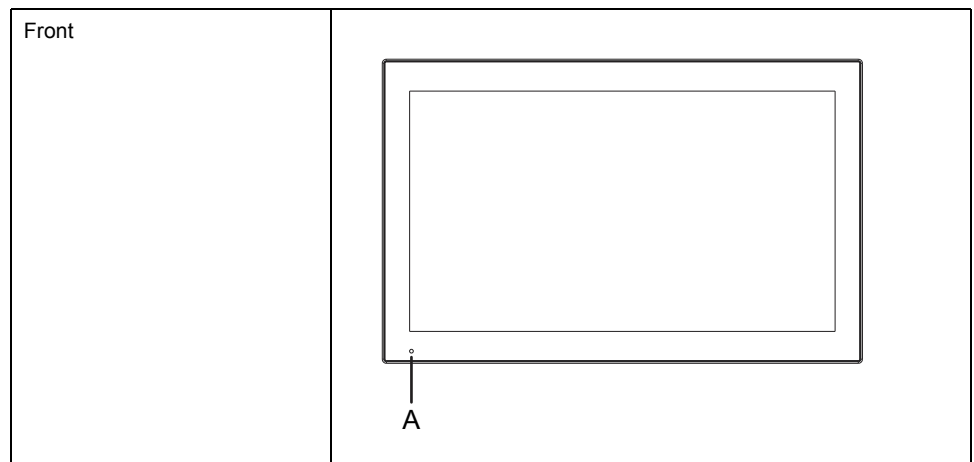

- A. Status LED

## Display Module LED Indications

### Status LED

Color	State	Description
Green	ON	In operation
	Flashing	Screen is turned off.
Orange	ON* <sup>1</sup>	S3, S4, S4 (hybrid shutdown)* <sup>2</sup> , S5
	Flashing	Either software starting up or internal error* <sup>3</sup>
Orange/Red	Alternating	System monitor error
–	OFF	Power is off.

\*1 Immediately after hibernation or when HORM is enabled, the LED on the Display Module turns orange right away, but turn off the power only after confirming the power LED on the Box Module has turned red.

\*2 S4 (hybrid shutdown) is S5 when Windows® fast startup is enabled.

\*3 Restart if flashing orange continues.

# Specifications

## What's in This Chapter

General Specifications.....	29
Functional Specifications .....	42
Interface Specifications.....	44

## General Specifications

### Electrical Specifications

#### Box Module

##### AC Model

Specification		AC model
Rated input voltage		100...240 Vac
Input voltage limits		85...264 Vac
Voltage drop (at rated input voltage)		20 ms or less
Power consumption	Max	Advanced Box: 140 VA Standard Box: 99 VA
	When power is not supplied to external devices	Advanced Box: 67 VA Standard Box: 48 VA
In-rush current		30 A or less
Noise immunity		Noise voltage: 1,500 Vp-p Pulse duration: 1 μs Rise time: 1 ns (via noise simulator)
Dielectric strength		1,500 Vac for 1 minute (between power terminal and PE terminal)
Insulation resistance		500 Vdc, 10 MΩ or more (between power terminal and PE terminal)

##### DC Model

Specification		DC model
Rated input voltage		24 Vdc
Input voltage limits		18...31.2 Vdc
Voltage drop (at rated input voltage)		5 ms or less
Power consumption	Max	Advanced Box: 121 W Standard Box: 87 W
	When power is not supplied to external devices	Advanced Box: 56 W Standard Box: 39 W
In-rush current		30 A or less
Noise immunity		Noise voltage: 1,000 Vp-p Pulse duration: 1 μs Rise time: 1 ns (via noise simulator)
Dielectric strength		1,000 Vac for 1 minute (between power terminal and FG terminal)
Insulation resistance		500 Vdc, 10 MΩ or more (between power terminal and FG terminal)

## Panel Type

### Advanced Model (AC Model)

Specification		AC model
Rated input voltage		100...240 Vac
Input voltage limits		85...264 Vac
Voltage drop (at rated input voltage)		20 ms or less
Power consumption	Max	12": 156 VA 15": 161 VA 12" Wide: 158 VA 15" Wide: 159 VA 19" Wide: 170 VA 22" Wide: 173 VA
	When power is not supplied to external devices	12": 83 VA 15": 88 VA 12" Wide: 85 VA 15" Wide: 86 VA 19" Wide: 97 VA 22" Wide: 100 VA
	When screen turns off (power is not supplied to external devices)	69 VA
In-rush current		30 A or less
Noise immunity		Noise voltage: 1,500 Vp-p Pulse duration: 1 $\mu$ s Rise time: 1 ns (via noise simulator)
Dielectric strength		1,500 Vac for 1 minute (between power terminal and PE terminal)
Insulation resistance		500 Vdc, 10 M $\Omega$ or more (between power terminal and PE terminal)

### Advanced Model (DC Model)

Specification		DC model
Rated input voltage		24 Vdc
Input voltage limits		18...31.2 Vdc
Voltage drop (at rated input voltage)		5 ms or less
Power consumption	Max	12": 136 W 15": 141 W 12" Wide: 138 W 15" Wide: 139 W 19" Wide: 150 W 22" Wide: 153 W
	When power is not supplied to external devices	12": 71 W 15": 76 W 12" Wide: 73 W 15" Wide: 74 W 19" Wide: 85 W 22" Wide: 88 W
	When screen turns off (power is not supplied to external devices)	58 W
In-rush current		30 A or less
Noise immunity		Noise voltage: 1,000 Vp-p Pulse duration: 1 $\mu$ s Rise time: 1 ns (via noise simulator)
Dielectric strength		1,000 Vac for 1 minute (between power terminal and FG terminal)
Insulation resistance		500 Vdc, 10 M $\Omega$ or more (between power terminal and FG terminal)

**Standard Model (AC Model)**

Specification		AC model
Rated input voltage		100...240 Vac
Input voltage limits		85...264 Vac
Voltage drop (at rated input voltage)		20 ms or less
Power consumption	Max	12": 77 VA 15": 82 VA 10" Wide: 74 VA 12" Wide: 79 VA 15" Wide: 80 VA 19" Wide: 92 VA 22" Wide: 95 VA
	When power is not supplied to external devices	12": 58 VA 15": 63 VA 10" Wide: 54 VA 12" Wide: 59 VA 15" Wide: 60 VA 19" Wide: 74 VA 22" Wide: 77 VA
	When screen turns off (power is not supplied to external devices)	50 VA
In-rush current		30 A or less
Noise immunity		Noise voltage: 1,500 Vp-p Pulse duration: 1 $\mu$ s Rise time: 1 ns (via noise simulator)
Dielectric strength		1,500 Vac for 1 minute (between power terminal and PE terminal)
Insulation resistance		500 Vdc, 10 M $\Omega$ or more (between power terminal and PE terminal)

**Standard Model (DC Model)**

Specification		DC model
Rated input voltage		24 Vdc
Input voltage limits		18...31.2 Vdc
Voltage drop (at rated input voltage)		5 ms or less
Power consumption	Max	12": 68 W 15": 72 W 10" Wide: 65 W 12" Wide: 69 W 15" Wide: 70 W 19" Wide: 82 W 22" Wide: 85 W
	When power is not supplied to external devices	12": 50 W 15": 54 W 10" Wide: 47 W 12" Wide: 51 W 15" Wide: 52 W 19" Wide: 64 W 22" Wide: 67 W
	When screen turns off (power is not supplied to external devices)	41 W
In-rush current		30 A or less
Noise immunity		Noise voltage: 1,000 Vp-p Pulse duration: 1 $\mu$ s Rise time: 1 ns (via noise simulator)
Dielectric strength		1,000 Vac for 1 minute (between power terminal and FG terminal)
Insulation resistance		500 Vdc, 10 M $\Omega$ or more (between power terminal and FG terminal)



## Environmental Specifications

**NOTE:**

- When using any of the options for this product, check the specifications for special conditions or cautions that may apply to this product.
- For Wall/ Flat/ Book (Top/Side) mounting and Panel (Landscape/Portrait) mounting, refer to Installation and Wiring, page 70.

### Box Module (Without HDD)

Physical environment		
Ambient air temperature (T-Code: T4)	Advanced Box	Wall/Book (Side) mounting: 0...55 °C (32...131 °F) with/without FAN kit
		Flat/Book (Top) mounting: 0...50 °C (32...122 °F) with/without FAN kit
	Standard Box	Wall/Book (Side) mounting: 0...55 °C (32...131 °F)
		Flat/Book (Top) mounting: 0...50 °C (32...122 °F)
Storage temperature	-30...70 °C (-22...158 °F)	
Ambient air and storage humidity	10...90% RH (non-condensing, wet bulb temperature 39 °C [102.2 °F] or less)	
Dust	0.1 mg/m <sup>3</sup> (10 <sup>-7</sup> oz/ft <sup>3</sup> ) or less (non-conductive levels)	
Pollution degree	For use in Pollution Degree 2 environment	
Corrosive gases	Free of corrosive gases	
Atmospheric pressure (operating altitude)	800...1,114 hPa (2,000 m [6,561 ft] or lower)	
Mechanical environment		
Vibration resistance	IEC/EN 61131-2 compliant 5...9 Hz Single amplitude 3.5 mm (0.14 in) 9...150 Hz Fixed acceleration: 9.8 m/s <sup>2</sup> X, Y, Z directions for 10 cycles (approximately 100 minutes)	
Shock resistance	IEC/EN 61131-2 compliant 147 m/s <sup>2</sup> , X, Y, Z directions for 3 times	
Electrical environment		
Electrical fast transient/ burst immunity	IEC 61000-4-4 2 kV: Power port 1 kV: Signal ports	
Electrostatic discharge immunity	Contact discharge method: 6 kV Air discharge method: 8 kV (IEC/EN 61000-4-2 Level 3)	

### Box Module (With HDD)

Physical environment		
Ambient air temperature (T-Code: T4)	Advanced Box	Wall/Book (Side) mounting: 0...45 °C (32...113 °F) with FAN kit <sup>1</sup>
		Flat/Book (Top) mounting: 0...45 °C (32...113 °F) with FAN kit <sup>1</sup>
	Standard Box	Wall/Book (Side) mounting: 0...40 °C (32...104 °F)
		Flat/Book (Top) mounting: 0...40 °C (32...104 °F)
Storage temperature	-30...70 °C (-22...158 °F)	
Ambient air and storage humidity	10...90% RH (non-condensing, wet bulb temperature 39 °C [102.2 °F] or less)	

Dust	0.1 mg/m <sup>3</sup> (10 <sup>-7</sup> oz/ft <sup>3</sup> ) or less (non-conductive levels)
Pollution degree	For use in Pollution Degree 2 environment
Corrosive gases	Free of corrosive gases
Atmospheric pressure (operating altitude)	800...1,114 hPa (2,000 m [6,561 ft] or lower)
<b>Mechanical environment</b>	
Vibration resistance	IEC 60068-2-6 compliant 5...9 Hz Single amplitude 1.75 mm (0.07 in) 9...150 Hz Fixed acceleration: 4.9 m/s <sup>2</sup> X, Y, Z directions for 10 cycles (approximately 100 minutes) <b>NOTE:</b> In an environment with vibrations, the read/write speed on the HDD may decrease.
Shock resistance	IEC/EN 61131-2 compliant 147 m/s <sup>2</sup> , X, Y, Z directions for 3 times
<b>Electrical environment</b>	
Electrical fast transient/burst immunity	IEC 61000-4-4 2 kV: Power port 1 kV: Signal ports
Electrostatic discharge immunity	Contact discharge method: 6 kV Air discharge method: 8 kV (IEC/EN 61000-4-2 Level 3)

\*1 The FAN kit is required when using this product with HDD installed.

## Panel Type (Without HDD)

<b>Physical environment</b>		
Ambient air temperature (T-Code: T4)	Advanced Model	Panel (Landscape) mounting: 0...55 °C (32...131 °F) with/without FAN kit (for 19-inch Wide and 22-inch Wide: 0...50 °C (32...122 °F) with/without FAN kit)
		Panel (Portrait) mounting: 0...50 °C (32...122 °F) with/without FAN kit
	Standard Model	Panel (Landscape) mounting: 0...55 °C (32...131 °F) (for 19-inch Wide and 22-inch Wide: 0...50 °C (32...122 °F))
		Panel (Portrait) mounting: 0...50 °C (32...122 °F)
Storage temperature	-20...60 °C (-4...140 °F)	
Ambient air and storage humidity	10...90% RH (non-condensing, wet bulb temperature 39 °C [102.2 °F] or less)	
Dust	0.1 mg/m <sup>3</sup> (10 <sup>-7</sup> oz/ft <sup>3</sup> ) or less (non-conductive levels)	
Pollution degree	For use in Pollution Degree 2 environment	
Corrosive gases	Free of corrosive gases	
Atmospheric pressure (operating altitude)	800...1,114 hPa (2,000 m [6,561 ft] or lower)	
<b>Mechanical environment</b>		
Vibration resistance	IEC/EN 61131-2 compliant 5...9 Hz Single amplitude 3.5 mm (0.14 in) 9...150 Hz Fixed acceleration: 9.8 m/s <sup>2</sup> X, Y, Z directions for 10 cycles (approximately 100 minutes) <b>NOTE:</b> The vibration resistance when using the 22-inch Wide model with PCI/PCIe slots attached is as follows. IEC 60068-2-6 compliant 5...9 Hz Single amplitude 1.75 mm (0.07 in) 9...150 Hz Fixed acceleration: 4.9 m/s <sup>2</sup> X, Y, Z directions for 10 cycles (approximately 100 minutes)	

Shock resistance	IEC/EN 61131-2 compliant 147 m/s <sup>2</sup> , X, Y, Z directions for 3 times
<b>Electrical environment</b>	
Electrical fast transient/ burst immunity	IEC 61000-4-4 2 kV: Power port 1 kV: Signal ports
Electrostatic discharge immunity	Contact discharge method: 6 kV Air discharge method: 8 kV (IEC/EN 61000-4-2 Level 3)

### Panel Type (With HDD)

<b>Physical environment</b>		
Ambient air temperature (T-Code: T4)	Advanced Model	Panel (Landscape) mounting: 0...45 °C (32...113 °F) with FAN kit*1
		Panel (Portrait) mounting: 0...45 °C (32...113 °F) with FAN kit*1
	Standard Model	Panel (Landscape) mounting: 0...40 °C (32...104 °F)
		Panel (Portrait) mounting: 0...40 °C (32...104 °F)
Storage temperature	-20...60 °C (-4...140 °F)	
Ambient air and storage humidity	10...90% RH (non-condensing, wet bulb temperature 39 °C [102.2 °F] or less)	
Dust	0.1 mg/m <sup>3</sup> (10 <sup>-7</sup> oz/ft <sup>3</sup> ) or less (non-conductive levels)	
Pollution degree	For use in Pollution Degree 2 environment	
Corrosive gases	Free of corrosive gases	
Atmospheric pressure (operating altitude)	800...1,114 hPa (2,000 m [6,561 ft] or lower)	
<b>Mechanical environment</b>		
Vibration resistance	IEC 60068-2-6 compliant 5...9 Hz Single amplitude 1.75 mm (0.07 in) 9...150 Hz Fixed acceleration: 4.9 m/s <sup>2</sup> X, Y, Z directions for 10 cycles (approximately 100 minutes) <b>NOTE:</b> In an environment with vibrations, the read/write speed on the HDD may decrease.	
Shock resistance	IEC/EN 61131-2 compliant 147 m/s <sup>2</sup> , X, Y, Z directions for 3 times	
<b>Electrical environment</b>		
Electrical fast transient/ burst immunity	IEC 61000-4-4 2 kV: Power port 1 kV: Signal ports	
Electrostatic discharge immunity	Contact discharge method: 6 kV Air discharge method: 8 kV (IEC/EN 61000-4-2 Level 3)	

\*1 The FAN kit is required when using this product with HDD installed.

### Air Quality Requirements

Do not operate or store the product where chemicals evaporate, or where chemicals are present in the air:

- Corrosive chemicals: Acids, alkalines, liquids containing salt.
- Flammable chemicals: Organic solvents.

**▲ CAUTION****INOPERATIVE EQUIPMENT**

Do not allow water, liquids, metal, and wiring fragments to enter the panel case.

**Failure to follow these instructions can result in injury or equipment damage.**

## Structural Specifications

### Box Module

Advanced Box	Standard Box
<b>Grounding</b>	
DC model: Functional grounding: Grounding resistance of 100 Ω or less, 2 mm <sup>2</sup> (AWG 14) or thicker wire, or your country's applicable standard (SG and FG are connected inside the product.) AC model: Protective grounding: Grounding resistance of 100 Ω or less, 2 mm <sup>2</sup> (AWG 14) or thicker wire, or your country's applicable standard (SG and PE are connected inside the product.)	
<b>Cooling method</b>	
Natural air circulation	
<b>External dimensions (W x H x D)</b>	
290 x 195 x 65 mm (11.42 x 7.68 x 2.56 in) with PCI/PCIe slots: 290 x 195 x 142 mm (11.42 x 7.68 x 5.59 in) with FAN kit: 290 x 195 x 98 mm (11.42 x 7.68 x 3.86 in)	250 x 165 x 53 mm (9.84 x 6.5 x 2.09 in)
<b>Weight</b>	
3.5 kg (7.72 lb) or less <sup>*1</sup>	2.5 kg (5.51 lb) or less

\*1 If the PCI/PCIe slot or FAN kit is connected, add the corresponding weight as follows:

PCI/PCIe slot: 1.5 kg (3.31 lb)  
FAN kit: 0.5 kg (1.10 lb)

### Panel Type

#### 12-inch Model

Specification	12-inch model	
Grounding	DC model: Functional grounding: Grounding resistance of 100 Ω or less, 2 mm <sup>2</sup> (AWG 14) or thicker wire, or your country's applicable standard (SG and FG are connected inside the product.) AC model: Protective grounding: Grounding resistance of 100 Ω or less, 2 mm <sup>2</sup> (AWG 14) or thicker wire, or your country's applicable standard (SG and PE are connected inside the product.)	
Cooling method	Natural air circulation	
Structure <sup>*1</sup>	When using a factory-installed front USB cover: IP65F, IP67F, UL 50/50E, Type 1 When using a front USB cover with screw (PFXZCDCVUS1): IP66F, IP67F, UL 50/50E, Type 1, Type 4X (indoor use only), Type 12, Type 13 <b>NOTE:</b> On the front panel when properly installed in an enclosure and not using the front panel USB port.	
External dimensions (W x H x D)	Advanced Box	315 x 241 x 95 mm (12.4 x 9.49 x 3.74 in) with PCI/PCIe slots: 315 x 241 x 172.4 mm (12.4 x 9.49 x 6.78 in) with FAN kit: 315 x 241 x 127.3 mm (12.4 x 9.49 x 5.01 in)
	Standard Box	315 x 241 x 83 mm (12.4 x 9.49 x 3.27 in)
Panel cut dimensions (W x H) <sup>*2 *3</sup>	301.5 x 227.5 mm (11.87 x 8.96 in)	
Weight	Advanced Box <sup>*4</sup>	5.9 kg (13.00 lb) or less
	Standard Box	4.9 kg (10.80 lb) or less

**NOTE:** Table notes appear at the bottom of the 22-inch Wide Model table.

**15-inch Model**

Specification	15-inch model	
Grounding	DC model: Functional grounding: Grounding resistance of 100 $\Omega$ or less, 2 mm <sup>2</sup> (AWG 14) or thicker wire, or your country's applicable standard (SG and FG are connected inside the product.) AC model: Protective grounding: Grounding resistance of 100 $\Omega$ or less, 2 mm <sup>2</sup> (AWG 14) or thicker wire, or your country's applicable standard (SG and PE are connected inside the product.)	
Cooling method	Natural air circulation	
Structure <sup>1</sup>	When using a factory-installed front USB cover: IP65F, IP67F, UL 50/50E, Type 1 When using a front USB cover with screw (PFXZCDCVUS1): IP66F, IP67F, UL 50/50E, Type 1, Type 4X (indoor use only), Type 12, Type 13 <b>NOTE:</b> On the front panel when properly installed in an enclosure and not using the front panel USB port.	
External dimensions (W x H x D)	Advanced Box	397 x 296 x 95 mm (15.63 x 11.65 x 3.74 in) with PCI/PCIe slots: 397 x 296 x 172.4 mm (15.63 x 11.65 x 6.78 in) with FAN kit: 397 x 296 x 127.3 mm (15.63 x 11.65 x 5.01 in)
	Standard Box	397 x 296 x 83 mm (15.63 x 11.65 x 3.27 in)
Panel cut dimensions (W x H) <sup>2 *3</sup>	383.5 x 282.5 mm (15.1 x 11.12 in)	
Weight	Advanced Box <sup>4</sup>	7.2 kg (15.87 lb) or less
	Standard Box	6.2 kg (13.67 lb) or less

**NOTE:** Table notes appear at the bottom of the 22-inch Wide Model table.

**10-inch Wide Model**

Specification	10-inch wide model	
Grounding	DC model: Functional grounding: Grounding resistance of 100 $\Omega$ or less, 2 mm <sup>2</sup> (AWG 14) or thicker wire, or your country's applicable standard (SG and FG are connected inside the product.) AC model: Protective grounding: Grounding resistance of 100 $\Omega$ or less, 2 mm <sup>2</sup> (AWG 14) or thicker wire, or your country's applicable standard (SG and PE are connected inside the product.)	
Cooling method	Natural air circulation	
Structure <sup>1</sup>	IP66F, IP67F, UL 50/50E, Type 1, Type 4X (indoor use only), Type 12, Type 13 <b>NOTE:</b> On the front panel when properly installed in an enclosure.	
External dimensions (W x H x D)	Standard Box	268.5 x 198.5 x 83 mm (10.57 x 7.81 x 3.27 in)
Panel cut dimensions (W x H) <sup>2 *3</sup>	255 x 185 mm (10.04 x 7.28 in)	
Weight	Standard Box	4.5 kg (9.92 lb) or less

**NOTE:** Table notes appear at the bottom of the 22-inch Wide Model table.

**12-inch Wide Model**

Specification	12-inch wide model	
Grounding	DC model: Functional grounding: Grounding resistance of 100 Ω or less, 2 mm <sup>2</sup> (AWG 14) or thicker wire, or your country's applicable standard (SG and FG are connected inside the product.) AC model: Protective grounding: Grounding resistance of 100 Ω or less, 2 mm <sup>2</sup> (AWG 14) or thicker wire, or your country's applicable standard (SG and PE are connected inside the product.)	
Cooling method	Natural air circulation	
Structure*1	IP66F, IP67F, UL 50/50E, Type 1, Type 4X (indoor use only), Type 12, Type 13 <b>NOTE:</b> On the front panel when properly installed in an enclosure.	
External dimensions (W x H x D)	Advanced Box	308.5 x 230.5 x 95 mm (12.15 x 9.07 x 3.74 in) with PCI/PCIe slots: 308.5 x 230.5 x 172.4 mm (12.15 x 9.07 x 6.78 in) with FAN kit: 308.5 x 230.5 x 127.3 mm (12.15 x 9.07 x 5.04 in)
	Standard Box	308.5 x 230.5 x 83 mm (12.15 x 9.07 x 3.27 in)
Panel cut dimensions (W x H)*2 *3	295 x 217 mm (16.14 x 8.54 in)	
Weight	Advanced Box*4	6.1 kg (13.45 lb) or less
	Standard Box	5.1 kg (11.24 lb) or less

**NOTE:** Table notes appear at the bottom of the 22-inch Wide Model table.

**15-inch Wide Model**

Specification	15-inch wide model	
Grounding	DC model: Functional grounding: Grounding resistance of 100 Ω or less, 2 mm <sup>2</sup> (AWG 14) or thicker wire, or your country's applicable standard (SG and FG are connected inside the product.) AC model: Protective grounding: Grounding resistance of 100 Ω or less, 2 mm <sup>2</sup> (AWG 14) or thicker wire, or your country's applicable standard (SG and PE are connected inside the product.)	
Cooling method	Natural air circulation	
Structure*1	IP66F, IP67F, UL 50/50E, Type 1, Type 4X (indoor use only), Type 12, Type 13 <b>NOTE:</b> On the front panel when properly installed in an enclosure.	
External dimensions (W x H x D)	Advanced Box	408 x 264 x 95 mm (16.06 x 10.39 x 3.74 in) with PCI/PCIe slots: 408 x 264 x 172.4 mm (16.06 x 10.39 x 6.78 in) with FAN kit: 408 x 264 x 127.3 mm (16.06 x 10.39 x 5.01 in)
	Standard Box	408 x 264 x 83 mm (16.06 x 10.39 x 3.27 in)
Panel cut dimensions (W x H)*2 *3	394 x 250 mm (15.51 x 9.84 in)	
Weight	Advanced Box*4	7.5 kg (16.53 lb) or less
	Standard Box	6.5 kg (14.33 lb) or less

**NOTE:** Table notes appear at the bottom of the 22-inch Wide Model table.

**19-inch Wide Model**

Specification	19-inch wide model	
Grounding	DC model: Functional grounding: Grounding resistance of 100 $\Omega$ or less, 2 mm <sup>2</sup> (AWG 14) or thicker wire, or your country's applicable standard (SG and FG are connected inside the product.) AC model: Protective grounding: Grounding resistance of 100 $\Omega$ or less, 2 mm <sup>2</sup> (AWG 14) or thicker wire, or your country's applicable standard (SG and PE are connected inside the product.)	
Cooling method	Natural air circulation	
Structure <sup>*1</sup>	IP66F, IP67F, UL 50/50E, Type 1, Type 4X (indoor use only), Type 12, Type 13  <b>NOTE:</b> On the front panel when properly installed in an enclosure.	
External dimensions (W x H x D)	Advanced Box	463.6 x 293.6 x 97 mm (18.25 x 11.56 x 3.82 in) with PCI/PCIe slots: 463.6 x 293.6 x 174.4 mm (18.25 x 11.56 x 6.87 in) with FAN kit: 463.6 x 293.6 x 129.3 mm (18.25 x 11.56 x 5.09 in)
	Standard Box	463.6 x 293.6 x 85 mm (18.25 x 11.56 x 3.35 in)
Panel cut dimensions (W x H) <sup>*2 *3</sup>	449.5 x 279.5 mm (17.7 x 11.0 in)	
Weight	Advanced Box <sup>*4</sup>	8.4 kg (18.52 lb) or less
	Standard Box	7.4 kg (16.31 lb) or less

**NOTE:** Table notes appear at the bottom of the 22-inch Wide Model table.

**22-inch Wide Model**

Specification	22-inch wide model	
Grounding	DC model: Functional grounding: Grounding resistance of 100 $\Omega$ or less, 2 mm <sup>2</sup> (AWG 14) or thicker wire, or your country's applicable standard (SG and FG are connected inside the product.) AC model: Protective grounding: Grounding resistance of 100 $\Omega$ or less, 2 mm <sup>2</sup> (AWG 14) or thicker wire, or your country's applicable standard (SG and PE are connected inside the product.)	
Cooling method	Natural air circulation	
Structure <sup>*1</sup>	IP66F, IP67F, UL 50/50E, Type 1, Type 4X (indoor use only), Type 12, Type 13  <b>NOTE:</b> On the front panel when properly installed in an enclosure.	
External dimensions (W x H x D)	Advanced Box	532.6 x 330.6 x 97 mm (20.97 x 13.02 x 3.82 in) with PCI/PCIe slots: 532.6 x 330.6 x 174.4 mm (20.97 x 13.02 x 6.87 in) with FAN kit: 532.6 x 330.6 x 129.3 mm (20.97 x 13.02 x 5.09 in)
	Standard Box	532.6 x 330.6 x 85 mm (20.97 x 13.02 x 3.35 in)
Panel cut dimensions (W x H) <sup>*2 *3</sup>	518.5 x 316.5 mm (20.41 x 12.46 in)	
Weight	Advanced Box <sup>*4</sup>	10.0 kg (22.05 lb) or less
	Standard Box	9.0 kg (19.84 lb) or less

\*1 The front face of this product, installed in a solid panel, has been tested using conditions equivalent to the standards shown in the specification. Even though this product's level of resistance is equivalent to these standards, oils that should have no effect on this product can possibly harm this product. This can occur in areas where either vaporized oils are present, or where low viscosity cutting oils are allowed to adhere to this product for long periods of time. If this product's front face protection sheet or cover glass peels off, these conditions can lead to the



ingress of oil into this product and separate protection measures are suggested. Also, if non-approved oils are present, they may cause deformation or corrosion of the front panel's cover. Therefore, prior to installing this product, be sure to confirm the type of conditions that will be present in this product 's operating environment.

If the installation gasket is used for a long period of time, or if this product and its gasket are removed from the panel, the original level of protection cannot be kept. To maintain the original protection level, be sure to replace the installation gasket regularly.

\*2 For dimensional tolerance, everything +1/-0 mm (+0.04/-0 in) and R in angle are below R3 (R0.12 in).

\*3 Even if the installation wall thickness is within the recommended range for the Panel Cut Dimensions, depending on wall's material, size, and installation location of this product and other devices, the installation wall could warp. To prevent warping, the installation surface may need to be strengthened.

\*4 If the PCI/PCIe slot or FAN kit is connected, add the corresponding weight as follows:

PCI/PCIe slot: 1.5 kg (3.31 lb)  
 FAN kit: 0.5 kg (1.10 lb)

<b><i>NOTICE</i></b>
<p><b>EQUIPMENT DAMAGE</b></p> <ul style="list-style-type: none"> <li>• Ensure this product is not in permanent and direct contact with oils.</li> <li>• Do not press on the display of this product with excessive force or with a hard object.</li> <li>• Do not press on the touch panel with a pointed object, such as the tip of a mechanical pencil or a screwdriver.</li> </ul> <p><b>Failure to follow these instructions can result in equipment damage.</b></p>

<b><i>NOTICE</i></b>
<p><b>EQUIPMENT DAMAGE</b></p> <p>Do not expose the device to direct sunlight.</p> <p><b>Failure to follow these instructions can result in equipment damage.</b></p>

<b><i>NOTICE</i></b>
<p><b>STORAGE AND OPERATION OUTSIDE OF SPECIFICATIONS</b></p> <ul style="list-style-type: none"> <li>• Store this product in areas where temperatures are within the product's specifications.</li> <li>• Do not restrict or block the product's ventilation slots.</li> </ul> <p><b>Failure to follow these instructions can result in equipment damage.</b></p>

<b><i>NOTICE</i></b>
<p><b>GASKET AGING</b></p> <ul style="list-style-type: none"> <li>• Inspect the gasket periodically as required by your operating environment.</li> <li>• Change the gasket at least once a year, or as soon as scratches or dirt become visible.</li> </ul> <p><b>Failure to follow these instructions can result in equipment damage.</b></p>

# Functional Specifications

## Performance Specifications

	Advanced Box			Standard Box
	Core i7	Core i5	Celeron	Core i3
CPU	Core™ i7-8665UE	Core™ i5-8365UE	Celeron® 4305UE	Core™ i3-8145UE
Base frequency	1.70 GHz	1.60 GHz	2.0 GHz	2.20 GHz
Max turbo boost frequency	4.40 GHz	4.10 GHz	2.0 GHz	3.90 GHz
L2 cache	8 MB	6 MB	2 MB	4 MB
Core number	4	4	2	2
Thread number	8	8	2	4
Main memory	260-pin SO-DIMM socket x 2, DDR4-2400 (Up to 16 GB/socket, up to 32 GB for 2 sockets)		260-pin SO-DIMM socket x 2, DDR4-2133 (Up to 16 GB/socket, up to 32 GB for 2 sockets)	260-pin SO-DIMM socket x 2, DDR4-2400 (Up to 16 GB/socket, up to 32 GB for 2 sockets)
Video memory	Shared memory (UMA) Maximum allocation size: Automatic allocation of up to half the installed main memory			
Storage slot	M.2 SSD SATA x 1 (Disk 0) 2.5-inch SATA (HDD/SSD) x 2 (top: Disk 2, bottom: Disk 1) SATA speed: 6 Gb/s, 3 Gb/s, 1.5 Gb/s			M.2 SSD SATA x 1 (Disk 0) 2.5-inch SATA (HDD/SSD) x 1 (Disk 1) SATA speed: 6 Gb/s, 3 Gb/s, 1.5 Gb/s
Expansion slot*1*2	PCI x 1 + PCIe x 1, PCIe x 2 or PCI x 2 PCI card size: Short length PCIe card size: Half length PCI slot: Revision 3.0, 32 bit bus, 3.3 Vdc PCIe slot: Revision 3.0, 1 Link (x1)*3			—
Graphics accelerator	Intel® UHD Graphics 620 (built in CPU)		Intel® UHD Graphics 610 (built in CPU)	Intel® UHD Graphics 620 (built in CPU)
Security chip	TPM 2.0			
BIOS	UEFI BIOS			
Operating system	Windows® 10 IoT Enterprise 2019 LTSC (64bit)			
Watchdog timer*4	Timeout setting from either 1 to 255 seconds, or 1 to 255 minutes, is possible (set up using API)			
Buzzer	Yes			

\*1 The total power consumption of PCI/PCIe cards can be up to 12 W, regardless of whether one or two cards are installed.

\*2 For dimensions of PCI/PCIe cards that can be installed, refer to *PCI/PCIe Card Installation*, page 97.

\*3 The PCIe connector is a x4 Link, edgeless type. However, only 1 Lane is connected for signals.

\*4 The watchdog timer is supported by products with the following system version.  
BIOS: WAR02 or later  
OS Base: 2.0 or later

You can check the system version from the Launcher. Refer to *System*, page 165. To use the watchdog timer on a product with a WAR01 BIOS, and OS Base 1.0, the BIOS and System Monitor must be updated. Follow the steps below to update.

1. BIOS: Contact the customer care center for instructions on how to update.
2. System Monitor: Download the driver (PFXPHMIP6\_Driver\_Installer\_Ver.x.x.zip) and utility (PFXPHMIP6\_Utility\_Installer\_Ver.x.x.zip) from our website and install them.  
<https://www.pro-face.com/trans/en/manual/1085.html>

## Display Specifications

### 12-inch and 15-inch

	12-inch	15-inch
Display type	TFT Color LCD	
Display size	12.1"	15"
Resolution	1,024 x 768 pixels (XGA)	
Effective display area (W x H)	245.76 x 184.32 mm (9.68 x 7.26 in)	304.13 x 228.1 mm (11.97 x 8.98 in)
Display colors	16 million colors	
Backlight	White LED (not user replaceable. Please contact customer support.)	
Backlight service life	50,000 hours or more (continuous operation at 25 °C [77 °F] before backlight brightness decreases to 25%)	
Brightness control	0...100 (adjusted with touch panel or software)	

### 10-inch Wide, 12-inch Wide, 15-inch Wide

	10-inch Wide	12-inch Wide	15-inch Wide
Display type	TFT Color LCD		
Display size	10.1"	12.1"	15.6"
Resolution	1,280 x 800 pixels (WXGA)		1,366 x 768 pixels (FWXGA)
Effective display area (W x H)	216.96 x 135.6 mm (8.54 x 5.34 in)	261.12 x 163.2 mm (10.28 x 6.43 in)	344.23 x 193.54 mm (13.55 x 7.62 in)
Display colors	16 million colors		
Backlight	White LED (not user replaceable. Please contact customer support.)		
Backlight service life	50,000 hours or more (continuous operation at 25 °C [77 °F] before backlight brightness decreases to 25%)		
Brightness control	0...100 (adjusted with touch panel or software)		

### 19-inch Wide and 22-inch Wide

	19-inch Wide	22-inch Wide
Display type	TFT Color LCD	
Display size	18.5"	21.5"
Resolution	1,920 x 1,080 pixels (FHD)	
Effective display area (W x H)	408.96 x 230.04 mm (16.1 x 9.06 in)	476.64 x 268.11 mm (18.77 x 10.56 in)
Display colors	16 million colors	
Backlight	White LED (not user replaceable. Please contact customer support.)	

	19-inch Wide	22-inch Wide
Backlight service life	50,000 hours or more (continuous operation at 25 °C [77 °F] before backlight brightness decreases to 25%)	
Brightness control	0...100 (adjusted with touch panel or software)	

## Touch Panel

	12-inch, 15-inch	10-inch Wide, 12-inch Wide, 15-inch Wide, 19-inch Wide, 22-inch Wide
Touch panel type	Resistive film (analog)	Projected capacitive with optimized noise filter
Touch points	Multi-touch (two-point touch)	Multi-touch (two-point touch)
Touch panel service life	10 million times or more	10 million times or more
Touch mode	Not applicable	<b>Standard mode, water detection mode, glove mode</b> <b>NOTE:</b> For details, refer to Touch Mode, page 165.

## Clock

Clock accuracy:  $\pm 180$  seconds/month (range of error at room temperature and no power)

The product's built-in clock, RTC, has a slight timing error. The range of the error is between +300 and -300 seconds/month, depending on product conditions such as years of use and temperature fluctuations. If you use this product in a system where timing is critical, adjust the clock at regular intervals.

**NOTE:** The expected battery service life is 5 years; however the battery may die before then. The battery is not user replaceable. Please contact customer support.

## Interface Specifications

### Interfaces

**NOTE:** Use only the SELV (Safety Extra-Low Voltage) circuit to connect all the interfaces.

### Box Module

		Advanced Box / Standard Box
Serial interface COM	Asynchronous transmission	RS-232C (not isolated) x 1
	Data length	7 or 8 bits
	Stop bit	1 or 2 bits
	Parity	None, odd or even
	Data transmission speed	2,400...115,200 bps
	Connector	D-Sub 9-pin (plug)
USB (Type A) interface	Connector	USB 3.0 (Type A) x 2 USB 2.0 (Type A) x 2
	Power supply voltage	5 Vdc ±5%
	Maximum current supplied	USB 3.0 (Type A): 900 mA/port USB 2.0 (Type A): 500 mA/port
	Maximum transmission distance	USB 3.0 (Type A): 3 m (9.84 ft) USB 2.0 (Type A): 5 m (16.4 ft)
USB (Type C) interface <sup>*1</sup>	Connector	USB 3.0 (Type C) x 1
	Power supply voltage	5 Vdc ±5% or 12 Vdc ±5%, USB power delivery (source) supported
	Maximum current supplied	900 mA/port 3000 mA/port when USB power delivery is enabled <sup>*2 *3</sup>
	Maximum transmission distance	3 m (9.84 ft)
	Resolution	Up to 4,096 x 2,304 pixels at 60 Hz
Ethernet interface	Standard	IEEE1588, 10 BASE-T/ 100 BASE-TX/ 1000BASE-T, Wake-on-LAN (WOL) supported <sup>*4</sup>
	Connector	Modular jack (RJ-45) x 2
DisplayPort	Version	V 1.2, dual mode (DP++) supported
	Resolution	Up to 4,096 x 2,304 pixels at 60 Hz

<sup>\*1</sup> The USB (Type C) interface supports alternate mode (DisplayPort) and USB power delivery (source, 5 Vdc/12 Vdc). When using USB power delivery, an E-Marked (electronically marked) cable is required.

<sup>\*2</sup> When Advanced Box is connected to the Display Module, the power supply capability of USB power delivery is limited to 30 W.

<sup>\*3</sup> For Standard Box, USB power delivery is effective only when Standard Box is used alone.

<sup>\*4</sup> When the status is S4 (hybrid shutdown), Wake-on-LAN is unavailable.

### Display Module

		12-inch / 15-inch
USB (Type A) interface	Connector	USB 2.0 (Type A) x 1
	Power supply voltage	5 Vdc ±5%
	Maximum current supplied	500 mA
	Maximum transmission distance	5 m (16.4 ft)

## Interface Connection

### Cable Connections

<b>⚠ WARNING</b>
<p><b>EXPLOSION HAZARD</b></p> <ul style="list-style-type: none"> <li>• Always confirm the UL 121201 or CSA C22.2 N°213 hazardous location rating of your device before installing or using it in a hazardous location.</li> <li>• To apply or remove the supply power from this product installed in a Class I, Division 2 hazardous location, you must either: A) Use a switch located outside the hazardous environment, or B) Use a switch certified for Class I, Division 1 operation inside the hazardous area.</li> <li>• Do not connect or disconnect equipment unless power has been switched off or the area is known to be non-hazardous. This applies to all connections including power, ground, serial, parallel, and network connections.</li> <li>• Never use unshielded/ungrounded cables in hazardous locations.</li> <li>• Use only non-incendive USB devices.</li> </ul> <p><b>Failure to follow these instructions can result in death, serious injury, or equipment damage.</b></p>

Division 2 hazardous location regulations require that all cable connections be provided with adequate strain relief and positive interlock. Use only non-incendive USB devices as USB connections do not provide adequate strain relief to allow the use of the USB connections of this product. Never connect or disconnect a cable while power is applied at either end of the cable. All communication cables should include a chassis ground shield. This shield should include both copper braid and aluminum foil. The D-sub style connector housing must be a metal conductive type (for example, molded zinc) and the ground shield braid must be terminated directly to the connector housing. Do not use a shield drain wire.

The outer diameter of the cable must be suited to the inner diameter of the cable connector strain relief so that a reliable degree of strain relief is maintained. Always secure the D-sub connectors to the workstation-mating connectors via the two screws located on both sides.

### USB Connection

Non-incendive field wiring apparatus (keyboards, mouse) are permitted for use on the front USB port (Type A) of associated field wiring non-incendive apparatus (this product).

In addition to being non-incendive, any equipment connected to the front USB ports must satisfy the following criteria.

The following figure shows the USB cable wiring (Document No.: NNZ2083601)

#### <Type A>

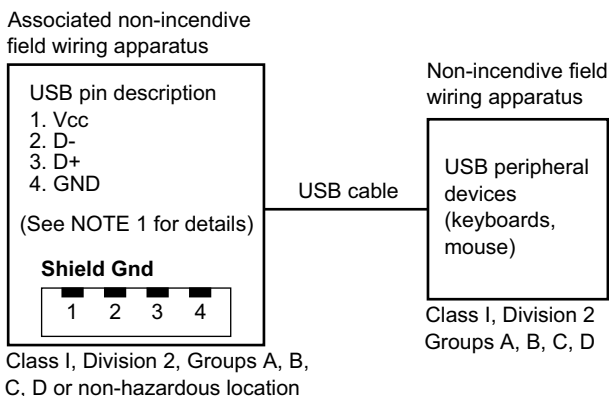

Circuit parameters	Front USB (Type A)
Open-circuit voltage = $V_{oc}$	5.25 Vdc
Short-circuit current = $I_{sc}$	1,560 mA
Associated capacitance = $C_a$	265 $\mu$ F
Associated inductance = $L_a$	16 $\mu$ H

<micro-B>

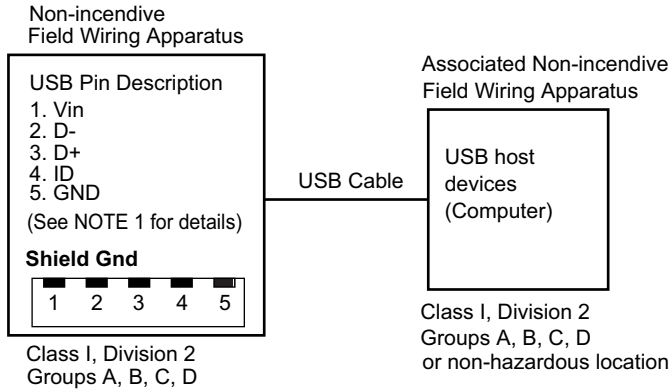

Circuit parameters	Front USB (micro-B)
Maximum input voltage = $V_{max}$	5.25 Vdc
Maximum load current = $I_{max}$	0.1 mA
Internal capacitance = $C_i$	0.12 $\mu$ F
Internal inductance = $L_i$	16 $\mu$ H

**NOTE:**

1. The above tables list the non-incendive circuit parameters.

The Entity Concept allows interconnection of non-incendive apparatus with associated apparatus – not specifically examined combinations – as a system when the approved values of  $V_{oc}$  (or  $U_o$ ) and  $I_{sc}$  (or  $I_o$ ) for the associated apparatus are less than or equal to  $V_{max}$  ( $U_i$ ) and  $I_{max}$  ( $I_i$ ) for the non-incendive apparatus, and the approved values of  $C_a$  ( $C_o$ ) and  $L_a$  ( $L_o$ ) for the associated apparatus are greater than or equal to  $C_i + C_{cable}$  and  $L_i + L_{cable}$ , respectively, for the non-incendive field wiring apparatus.

2. Associated non-incendive field wiring apparatus and non-incendive field wiring apparatus shall satisfy the following:

Associated non-incendive field wiring apparatus	—	Non-incendive field wiring apparatus
$V_{oc}$	$\leq$	$V_{max}$
$I_{sc}$	$\leq$	$I_{max}$
$C_a$	$\geq$	$C_i + C_{cable}$
$L_a$	$\geq$	$L_i + L_{cable}$

3. If the electrical parameters of the cable are unknown, the following values may be used:

$C_{cable} = 196.85 \text{ pF/m (60 pF/ft)}$

$L_{cable} = 0.656 \text{ } \mu\text{H/m (0.20 } \mu\text{H/ft)}$

4. Wiring methods must be in accordance with the electrical code of the country where it is used.

This product must be installed in an enclosure. If installed in a Class I, Division 2 location, the enclosure must be capable of accepting one or more Division 2 wiring methods.

## ⚠ WARNING

### EXPLOSION HAZARD

- Verify the power, input, and output (I/O) wiring are in accordance with Class I, Division 2 wiring methods.
- Do not use this product in hazardous environments or locations other than Class I, Division 2, Groups A, B, C, and D.
- Substitution of any components may impair suitability for Class I, Division 2.
- Do not disconnect equipment while the circuit is live or unless the area is known to be free of ignitable concentrations.
- Remove power before attaching or detaching any connectors to or from this product.
- Ensure that power, communication, and accessory connections do not place excessive stress on the ports. Consider the vibration in the environment when making this determination.
- Securely attach power, communication, and external accessory cables to the panel or cabinet.
- Use only commercially available USB cables.
- Use only non-incendive USB configurations.
- Confirm that the USB cable has been attached with the USB cable clamp before using the USB interface.

**Failure to follow these instructions can result in death, serious injury, or equipment damage.**

## Serial Interface (COM on Box Module)

### Introduction

The serial interface is not isolated. The SG (signal ground) and FG (frame ground) terminals are connected inside this product. When the serial interface connector is D-Sub, connect the FG wire to the shell.

## ⚡⚠ DANGER

### ELECTRIC SHOCK AND FIRE

When using the SG terminal to connect an external device to this product:

- Verify that a ground loop is not created when you set up the system.
- Connect the SG terminal to remote equipment when the external device is not isolated.
- Connect the SG terminal to a known reliable ground connection to reduce the risk of damaging the circuit.

**Failure to follow these instructions will result in death or serious injury.**

## ⚠ CAUTION

### LOSS OF COMMUNICATION

- Do not put excessive stress on the communication ports of all connections.
- Securely attach communication cables to the panel wall or cabinet.
- Use a D-Sub 9 pin connector that has jack screws.

**Failure to follow these instructions can result in injury or equipment damage.**



**NOTE:** Use within the rated current.

### RS-232C

D-Sub 9 pin plug connector

Product side:

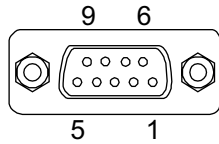

Pin No.	RS-232C		
	Signal name	Direction	Description
1	CD	Input	Carrier detect
2	RD (RXD)	Input	Receive data
3	SD (TXD)	Output	Send data
4	ER (DTR)	Output	Data terminal ready
5	SG	-	Signal ground (not isolated)
6	DR (DSR)	Input	Data set ready
7	RS (RTS)	Output	Request to send
8	CS (CTS)	Input	Send possible
9	CI (RI)	Input	Called status display
Shell	FG	-	Frame ground (common with SG)

Recommended jack screw is #4-40 (UNC).

# Dimensions

## What's in This Chapter

Advanced Box.....	50
Standard Box.....	53
Panel Type - Advanced Model.....	55
Panel Type - Standard Model.....	65
Installation Fastener.....	69

## Advanced Box

### External Dimensions

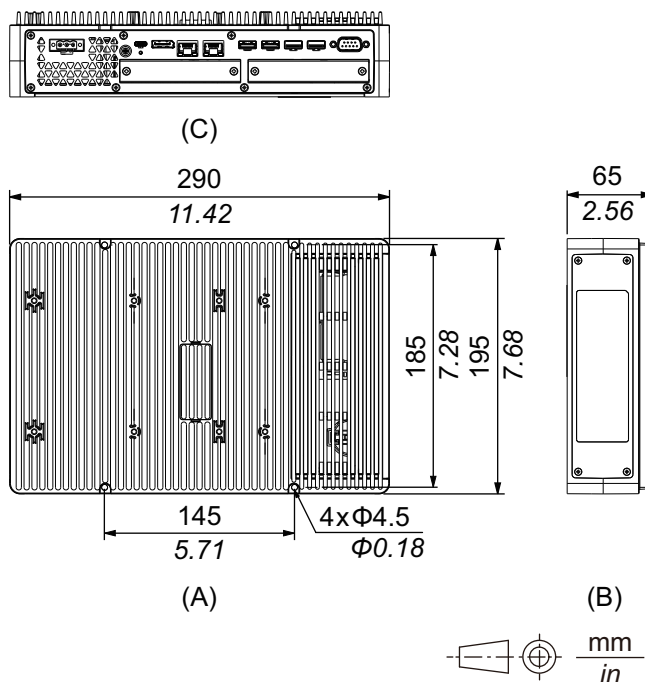

- A. Front
- B. Left
- C. Bottom

### External Dimensions with PCI/PCle Slots and FAN kit

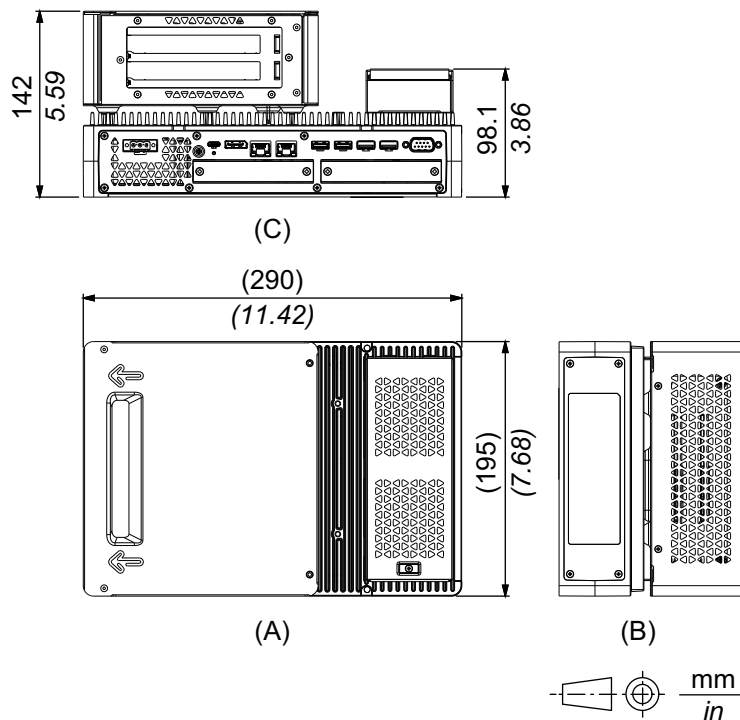

- A. Front
- B. Left
- C. Bottom

### Dimensions with Book Mount Adapter (Top)

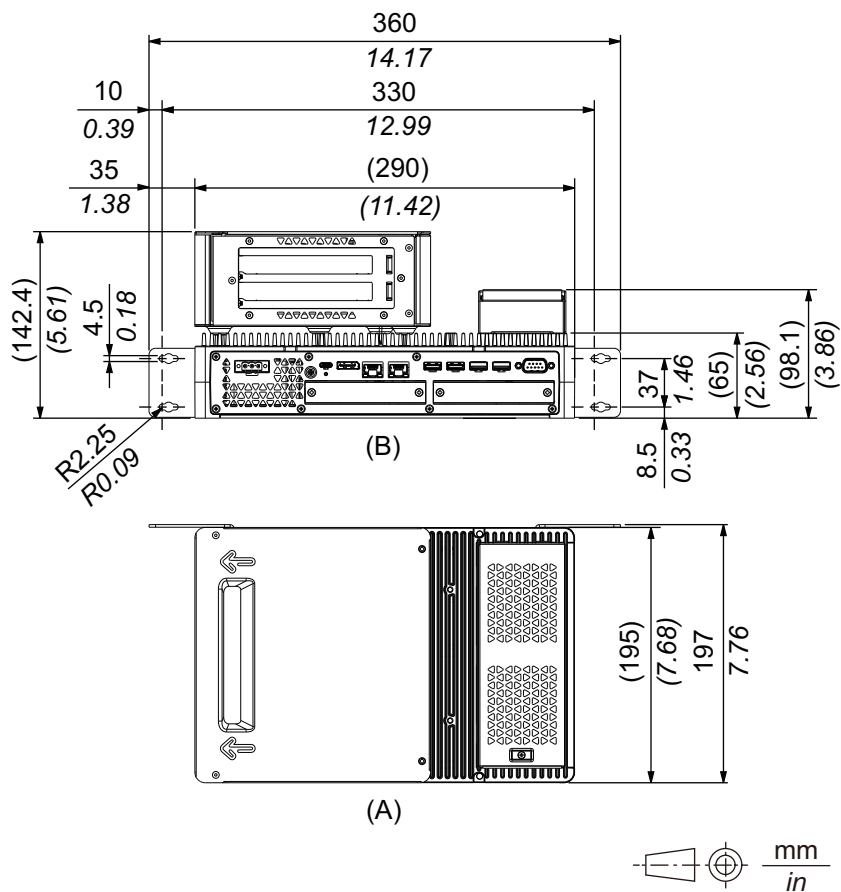

- A. Front

B. Bottom

Dimensions with Book Mount Adapter (Side)

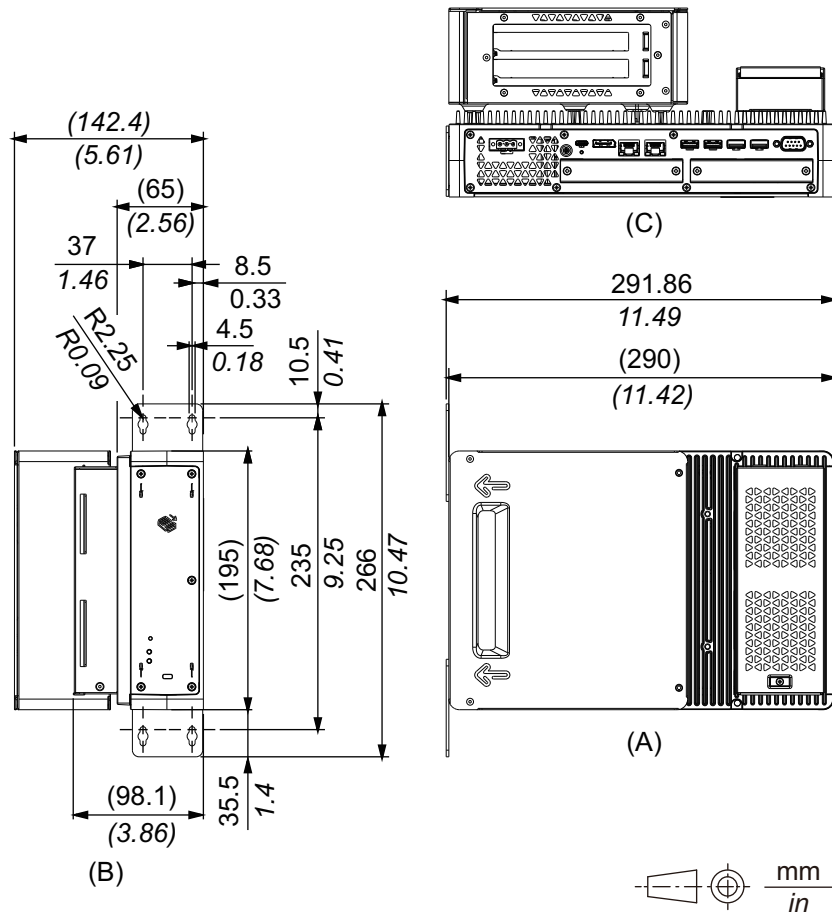

- A. Front
- B. Right
- C. Bottom

## Dimensions with Flat/Wall Mount Adapter

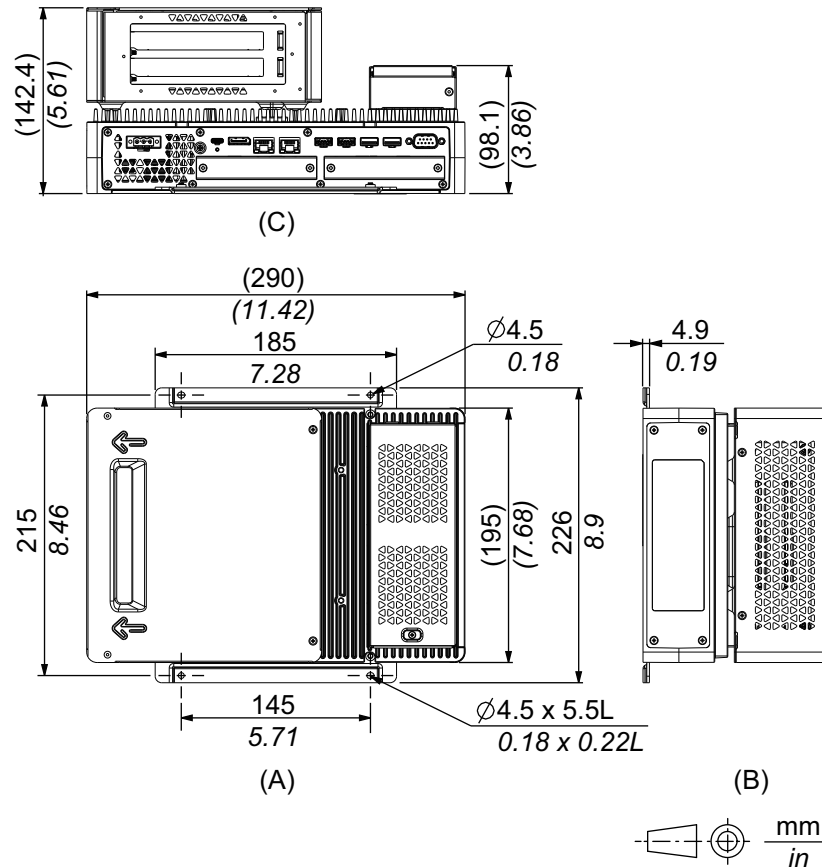

- A. Front
- B. Left
- C. Bottom

## Standard Box

### External Dimensions

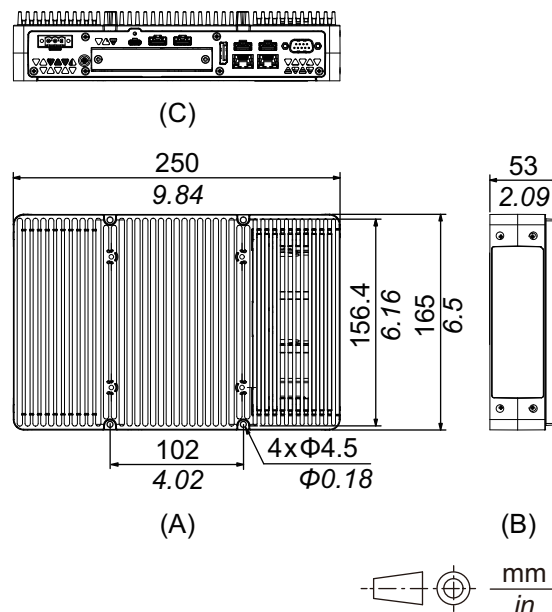

- A. Front
- B. Left
- C. Bottom

**Dimensions with Book Mount Adapter (Top)**

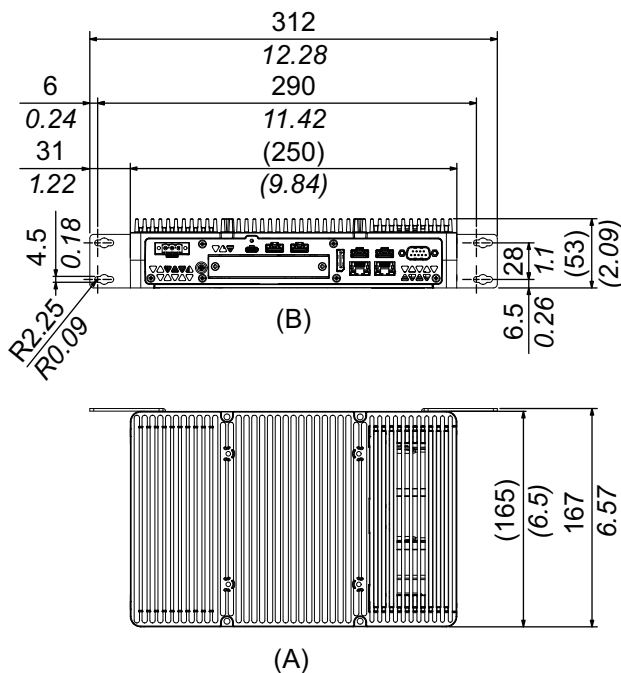

- A. Front
- B. Bottom

**Dimensions with Book Mount Adapter (Side)**

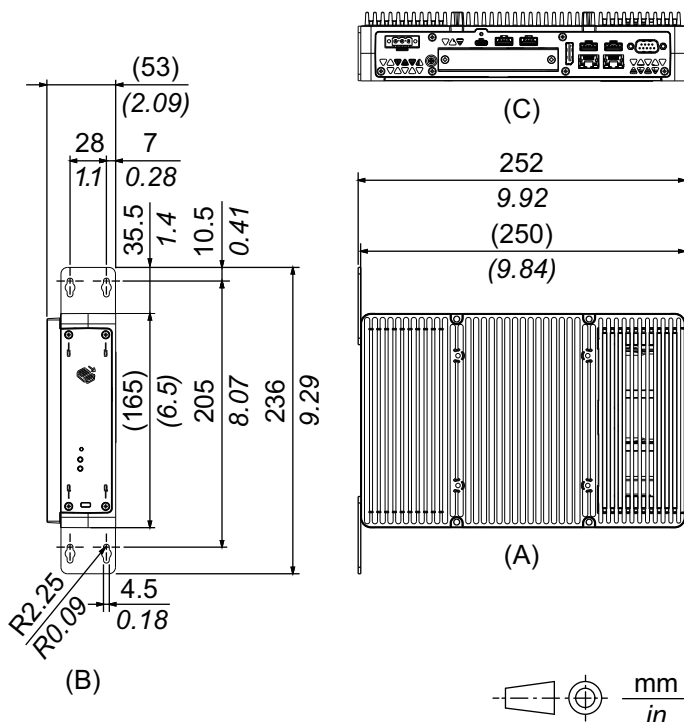

- A. Front
- B. Right

C. Bottom

# Panel Type - Advanced Model

## 12-inch Advanced Model

### External Dimensions

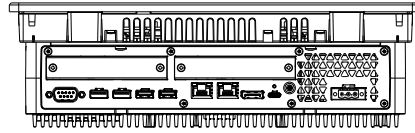

(C)

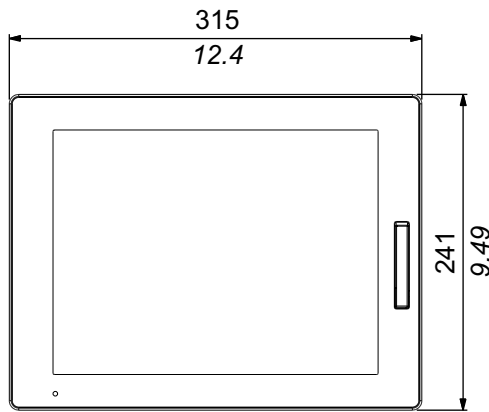

(A)

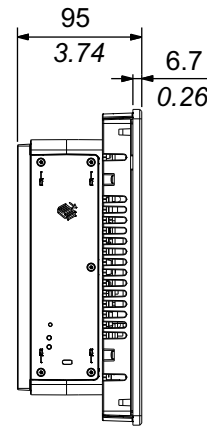

(B)



- A. Front
- B. Left
- C. Bottom

### External Dimensions with PCI/PCIe Slots and FAN kit

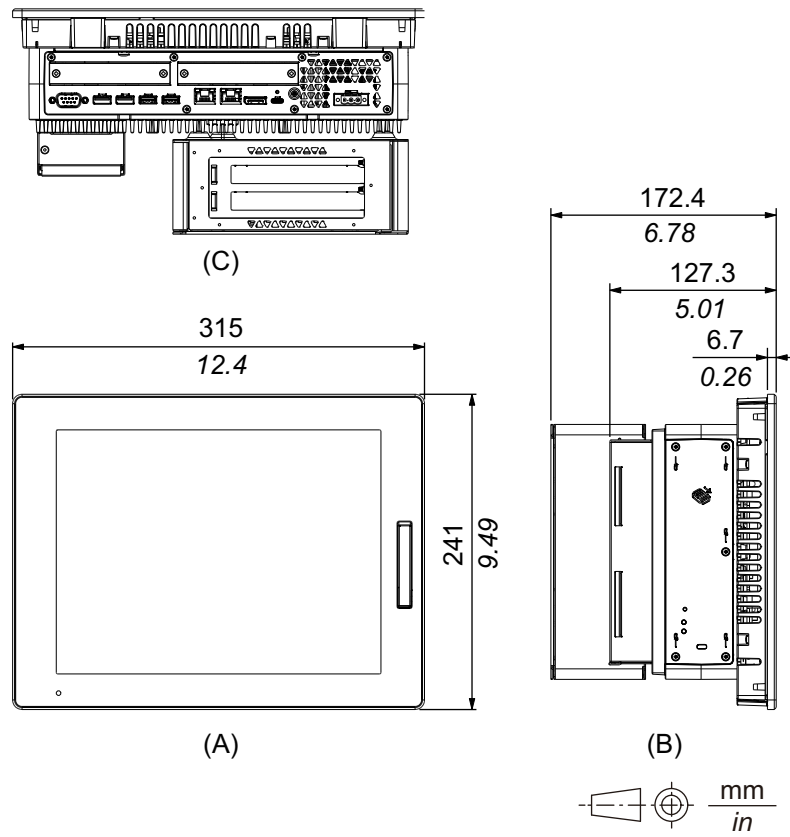

- A. Front
- B. Left
- C. Bottom



# 15-inch Advanced Model

## External Dimensions

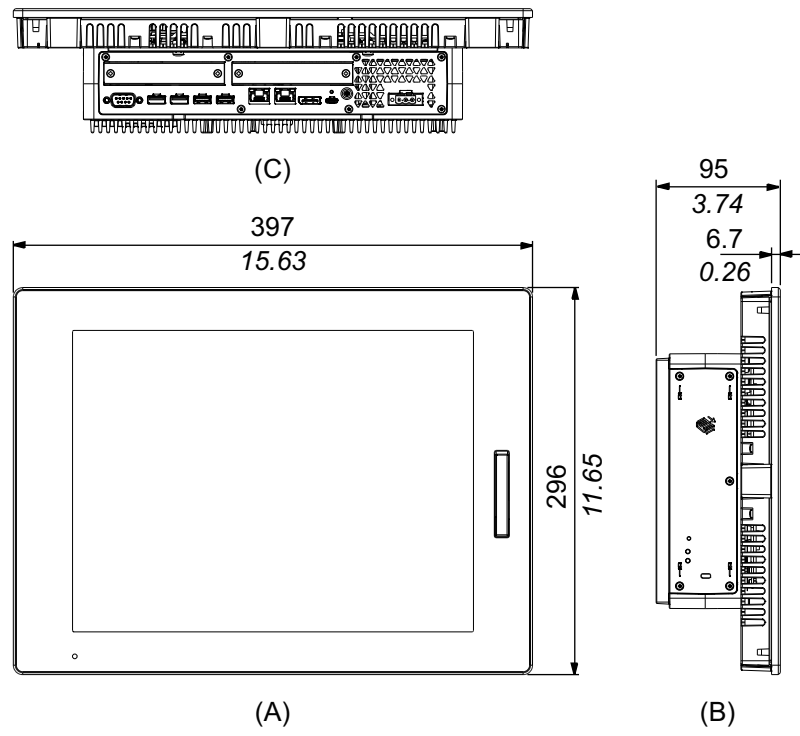

- A. Front
- B. Left
- C. Bottom

### External Dimensions with PCI/PCIe Slots and FAN kit

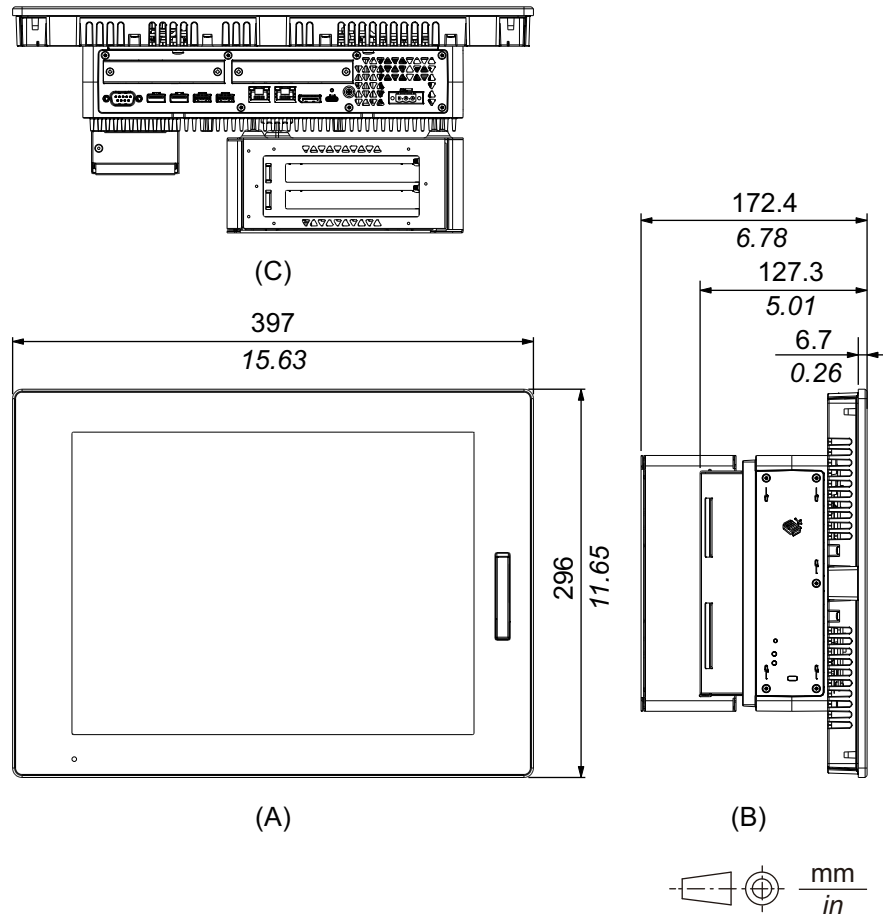

- A. Front
- B. Left
- C. Bottom

## 12-inch Wide Advanced Model

### External Dimensions

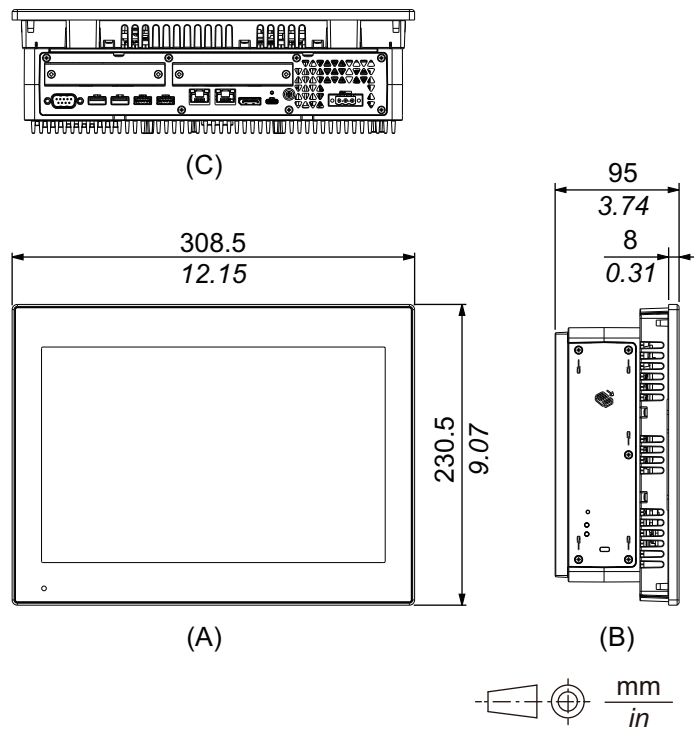

- A. Front
- B. Left
- C. Bottom

### External Dimensions with PCI/PCIe Slots and FAN kit

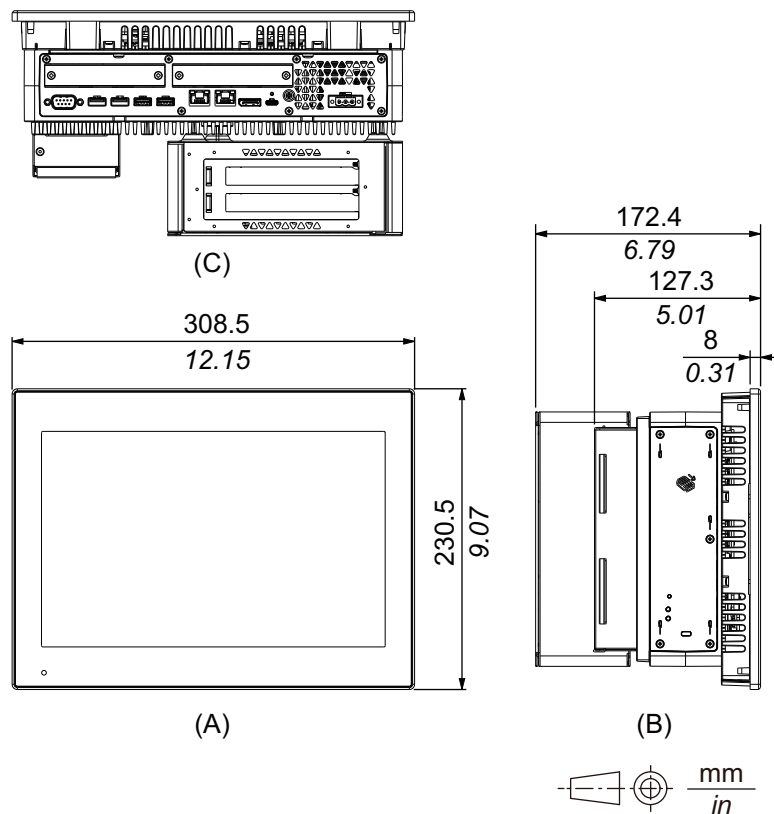

- A. Front
- B. Left
- C. Bottom

**15-inch Wide Advanced Model**

**External Dimensions**

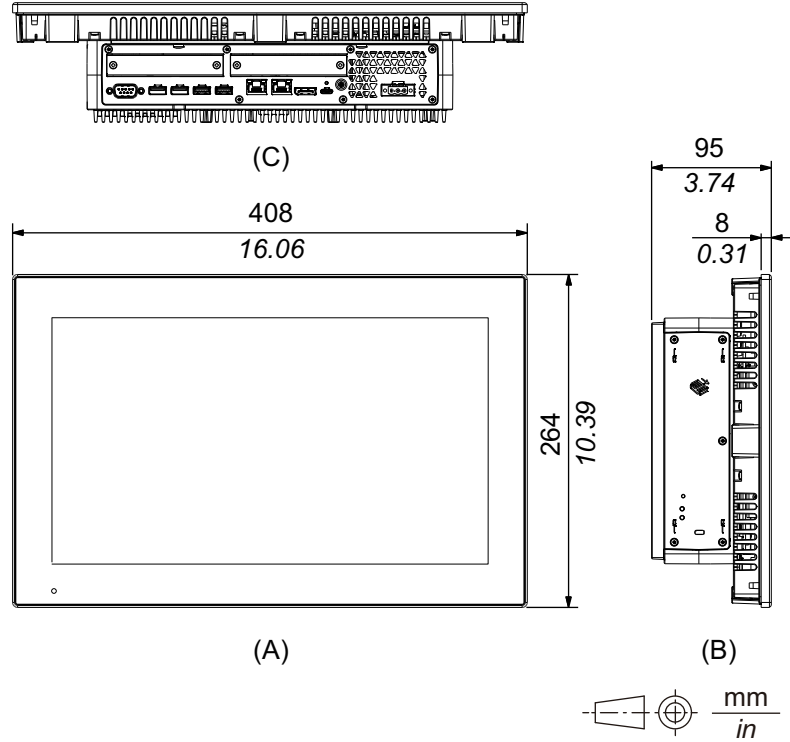

- A. Front
- B. Left
- C. Bottom

### External Dimensions with PCI/PCIe Slots and FAN kit

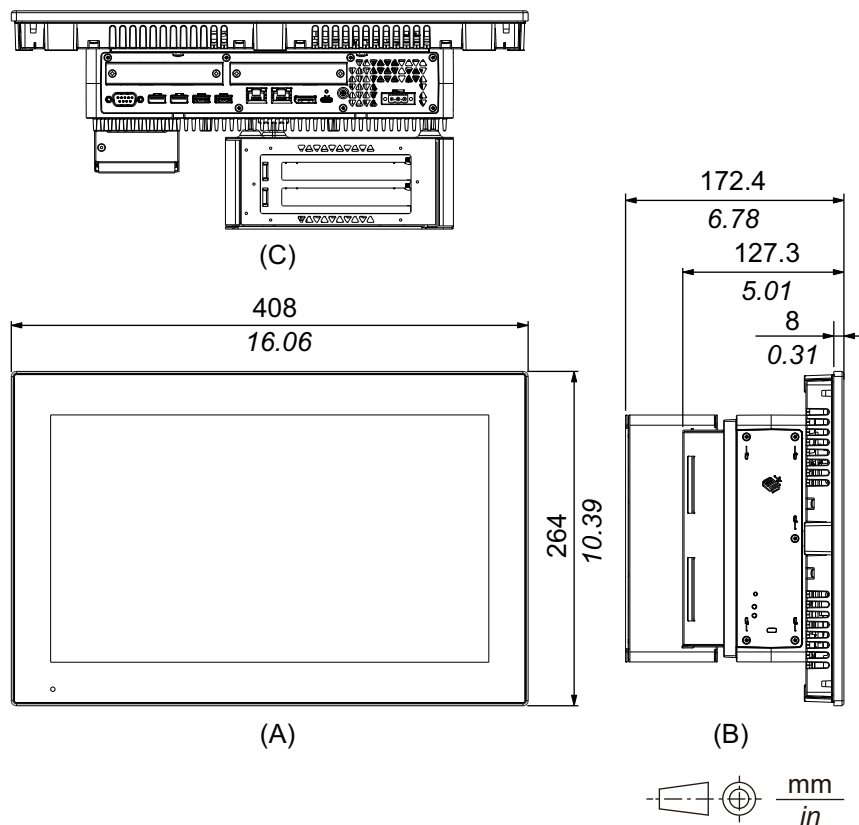

- A. Front
- B. Left
- C. Bottom

### 19-inch Wide Advanced Model

#### External Dimensions

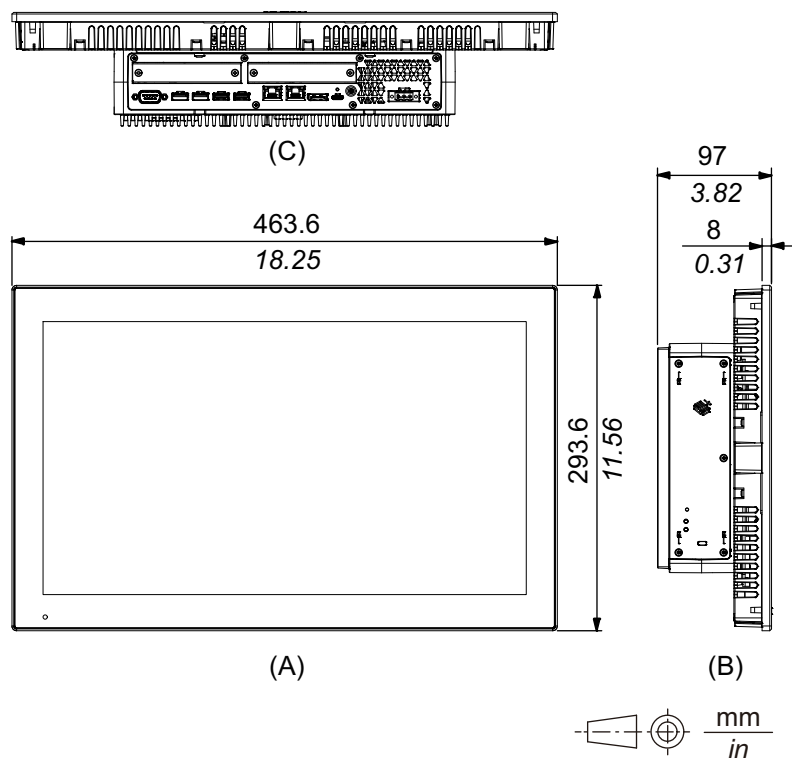

- A. Front

- B. Left
- C. Bottom

**External Dimensions with PCI/PCIe Slots and FAN kit**

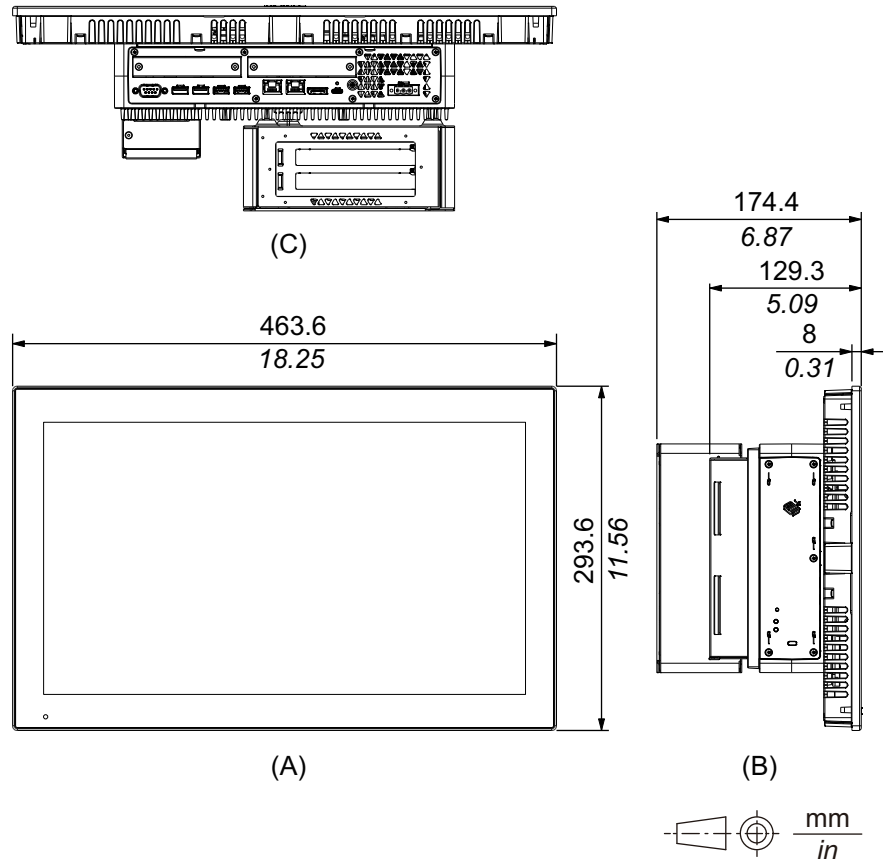

- A. Front
- B. Left
- C. Bottom

## 22-inch Wide Advanced Model

### External Dimensions

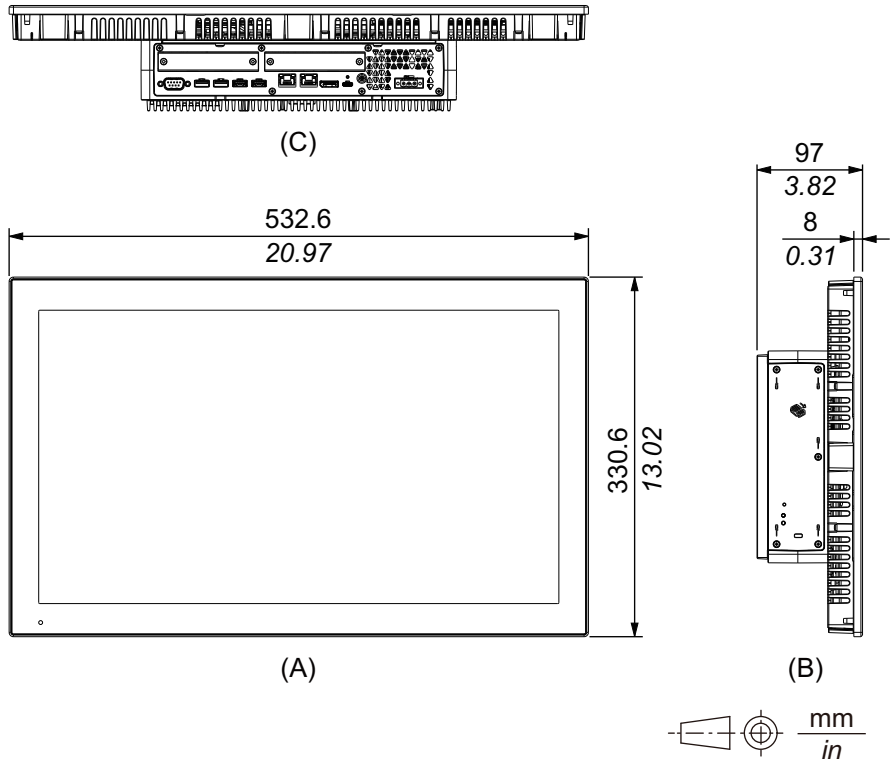

- A. Front
- B. Left
- C. Bottom

### External Dimensions with PCI/PCIe Slots and FAN kit

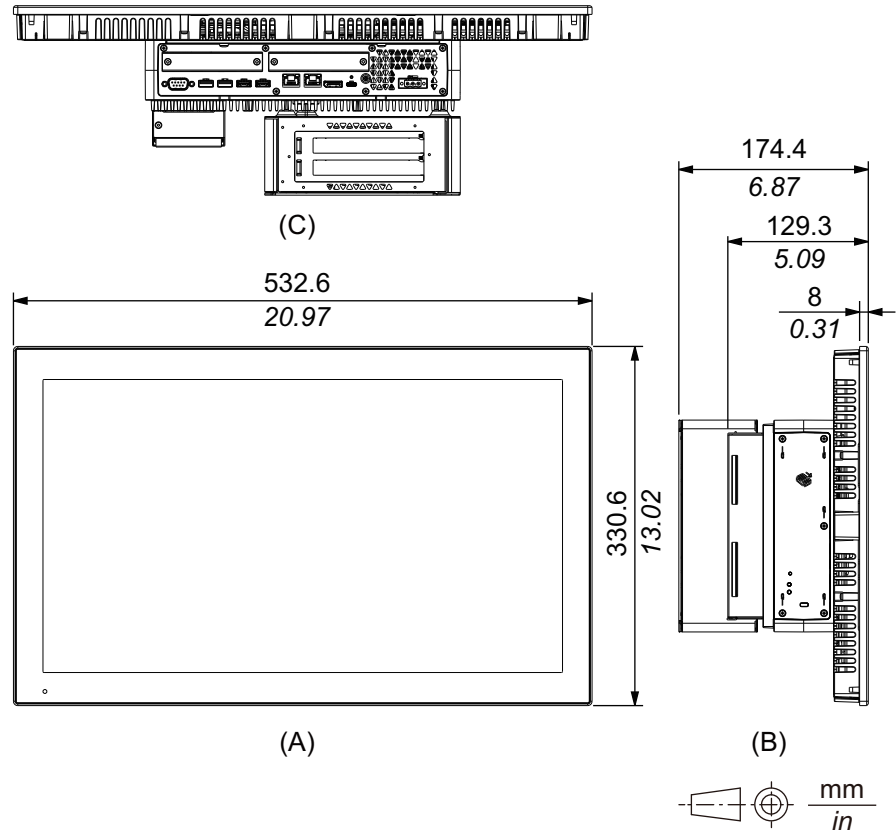

- A. Front
- B. Left
- C. Bottom



# Panel Type - Standard Model

## 12-inch Standard Model

### External Dimensions

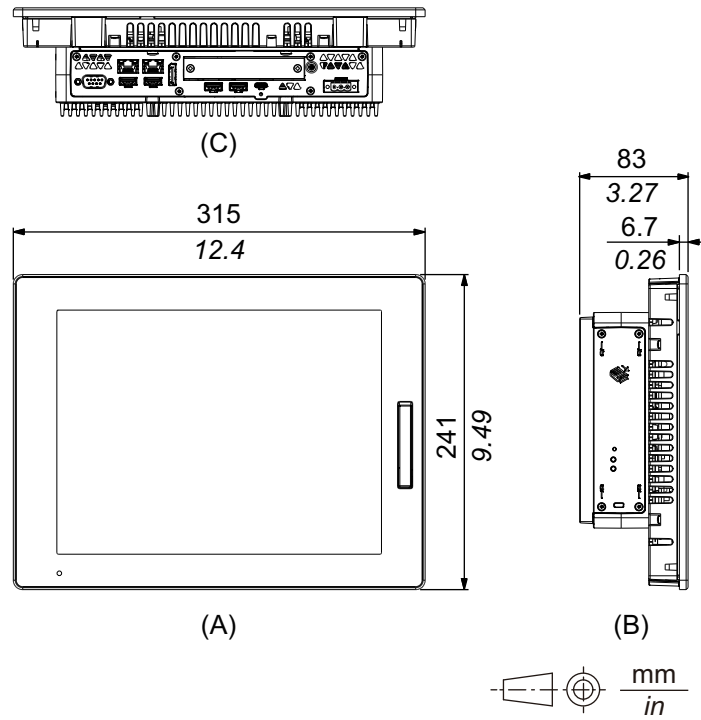

- A. Front
- B. Left
- C. Bottom

### 15-inch Standard Model

#### External Dimensions

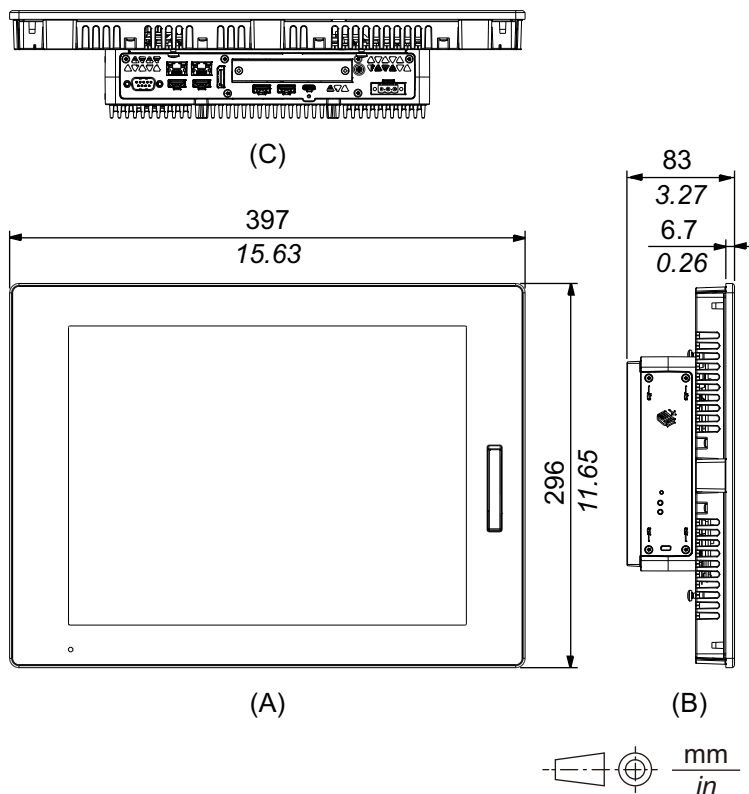

- A. Front
- B. Left
- C. Bottom

### 10-inch Wide Standard Model

#### External Dimensions

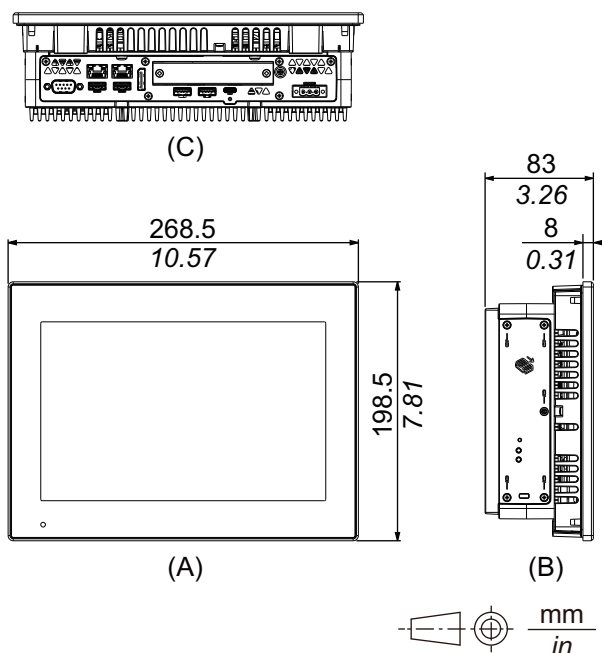

- A. Front

- B. Left
- C. Bottom

### 12-inch Wide Standard Model

#### External Dimensions

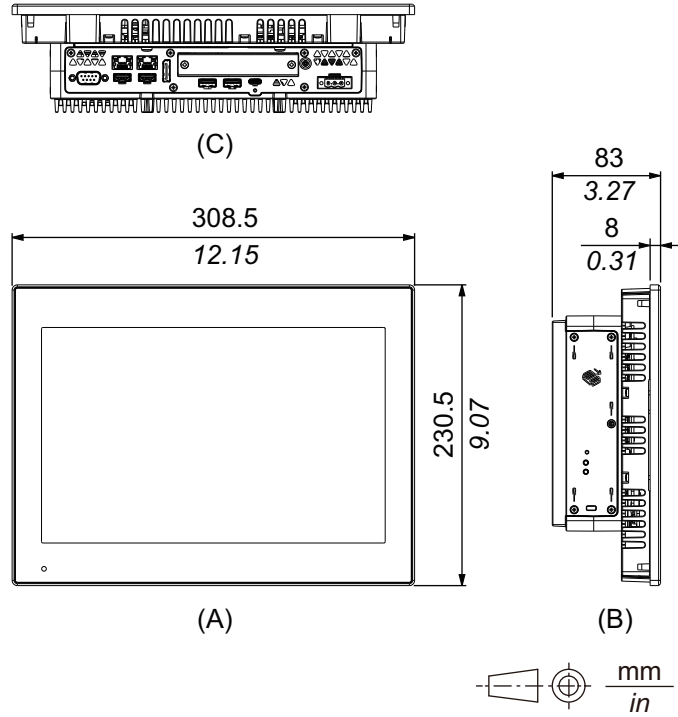

- A. Front
- B. Left
- C. Bottom

15-inch Wide Standard Model

External Dimensions

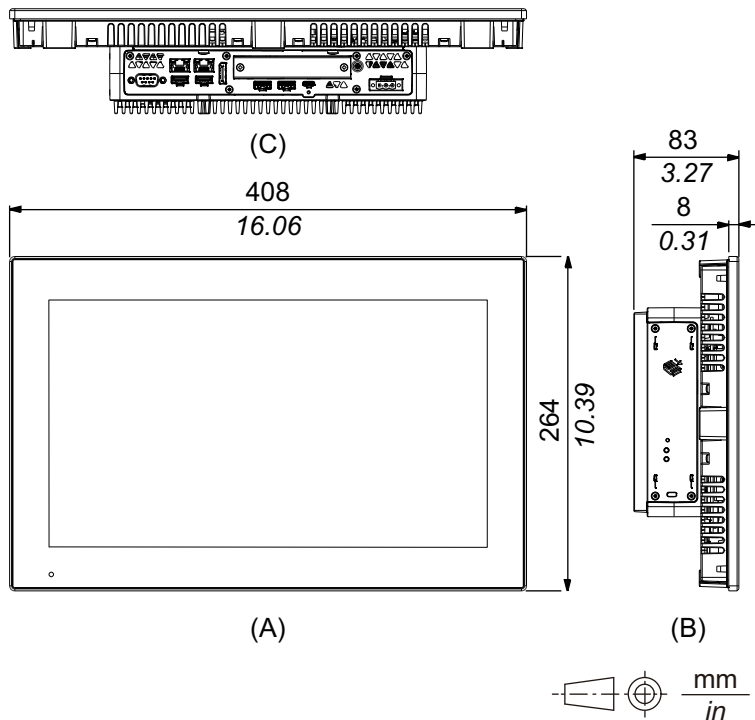

- A. Front
- B. Left
- C. Bottom

19-inch Wide Standard Model

External Dimensions

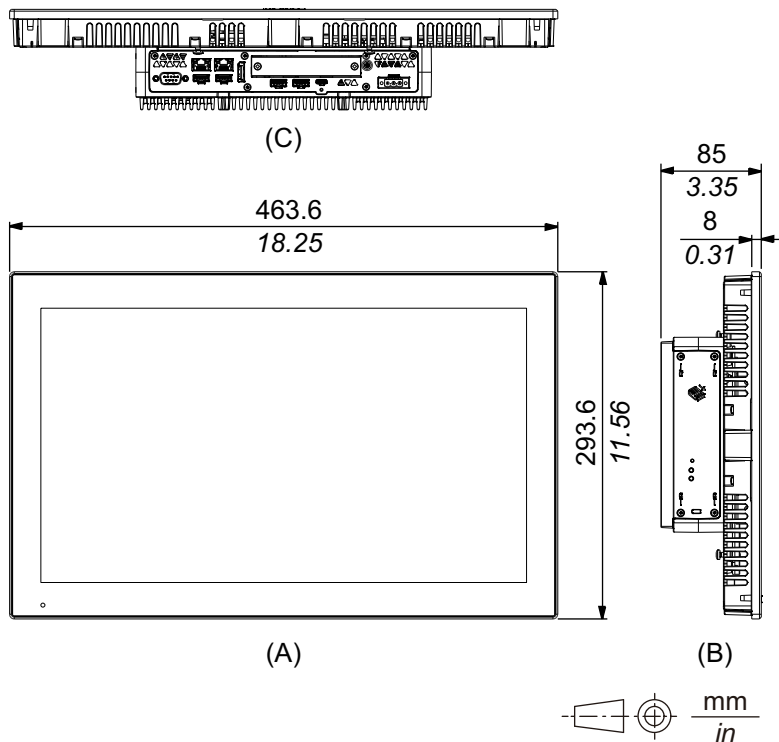

- A. Front
- B. Left

C. Bottom

## 22-inch Wide Standard Model

### External Dimensions

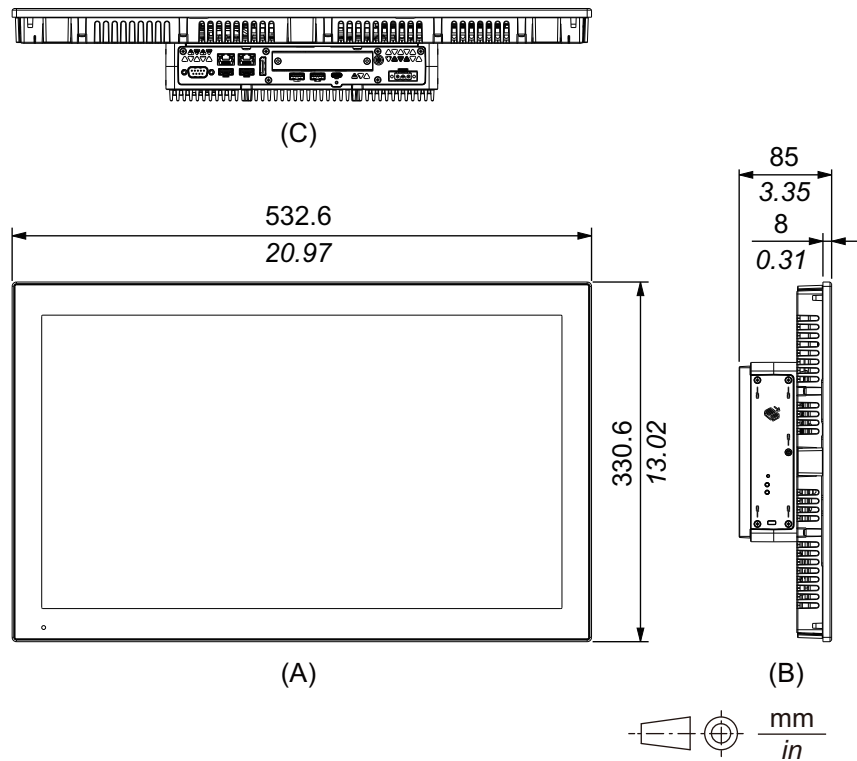

- A. Front
- B. Left
- C. Bottom

## Installation Fastener

### External Dimensions

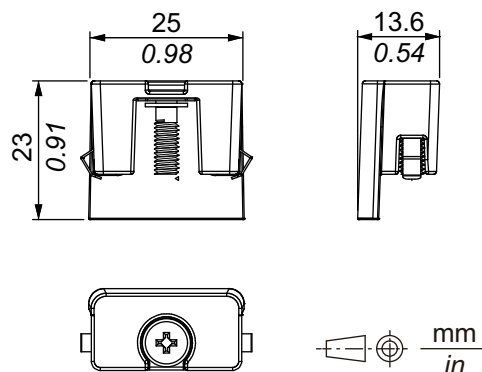

# Installation and Wiring

## What's in This Chapter

Installation Requirements.....	70
Box Module Installation.....	72
Panel Type Installation.....	78
Wiring the Power Supply.....	83
Storage Installation.....	90
Expansion Slot Installation .....	97
Memory Installation .....	100
Optional Interface Installation .....	102
USB Type A/Type C Cable Clamp.....	142
Front USB Cover.....	144
FAN Kit.....	145

## Installation Requirements

This product is designed for use on flat surfaces of UL 50/50E, Type 1, Type 4X (indoor use only), Type 12 or Type 13 enclosure.

Mount this product in an enclosure that provides a clean, dry, robust and controlled environment (IP65F, IP66F, IP67F, UL 50/50E, Type 1, Type 4X [indoor use only], Type 12 or Type 13 enclosure).

For 10-inch Wide, 12-inch Wide, 15-inch Wide, 19-inch Wide and 22-inch Wide models, the front surface is rated for IP66F, IP67F, UL 50/50E, Type 1, Type 4X (indoor use only), Type 12 and Type 13 enclosure.

For 12-inch and 15-inch models, when using a factory-installed front USB cover (without screw), the front surface is rated for IP65F, IP67F, UL 50/50E and Type 1 enclosures. When using a front USB cover (with screw) (PFXZCDCVUS1), the front surface is rated for IP66F, IP67F, UL 50/50E, Type 1, Type 4X (indoor use only), Type 12 and Type 13 enclosure.

Display front surface		10-inch Wide/ 12-inch Wide/ 15-inch Wide/ 19-inch Wide/ 22-inch Wide	Enclosure front surface
12-inch and 15-inch			
Without screw	With screw		
IP65F, IP67F, UL 50/50E, Type 1	IP66F, IP67F, UL 50/50E, Type 1, Type 4X (indoor use only), Type 12, Type 13	IP66F, IP67F, UL 50/50E, Type 1, Type 4X (indoor use only), Type 12, Type 13	IP65F, IP66F, IP67F, UL 50/50E, Type 1, Type 4X (indoor use only), Type 12, Type 13

For 12-inch and 15-inch models, regardless of using a factory-installed front USB cover or a front USB cover with screw, when the front USB cover is open, the front surface is rated for UL 50/50E and Type 1 enclosure.

Be aware of the following when building this product into an end-use product:

- The rear face of this product is not approved as an enclosure. When building this product into an end-use product, be sure to use an enclosure that satisfies standards as the end-use product's overall enclosure.
- Install this product in an enclosure with mechanical rigidity.
- This product is not designed for outdoor use. UL certification obtained is for indoor use only.
- Install and operate this product with its front panel facing outward.

**NOTE:** IP65F, IP66F and IP67F are not part of UL certification.

## ⚠ CAUTION

### RISK OF BURNING INJURY

- Do not touch the bezel or rear chassis during operation.
- Wear appropriate gloves when operating the front USB in ambient temperatures greater than 45 °C (113 °F).

**Failure to follow these instructions can result in injury or equipment damage.**

- **Box Module:**

Depending on the panel's material and design, the panel's installation surface may need to be strengthened. If high levels of vibration are expected and this product's installation surface can move (such as because of a panel door opening or closing), due consideration should be given to this product's weight.

**Panel Type:**

Check that the installation wall or cabinet surface is flat, in good condition and has no jagged edges. Metal reinforcing strips may be attached to the inside of the wall, near the panel-cut, to increase its rigidity.

- **Box Module:**

Determine the thickness of the panel in consideration of its material and strength as well as the environment in which this product is used. The thickness must be 1.6 mm (0.06 in) or more, considering the length of M4 screws.

**Panel Type:**

Decide on the thickness of the enclosure wall, based on the level of strength required. Even if the installation wall thickness is within the recommended range for the Panel Cut Dimensions, depending on wall's material, size, and installation location of this product and other devices, the installation wall could warp. To prevent warping, the installation surface may need to be strengthened.

- Check that the ambient air temperature and the ambient humidity are within their specified ranges in *Environmental Specifications*, page 33. When installing this product in a cabinet or enclosure, the ambient air temperature is the cabinet's or enclosure's internal and external temperature.

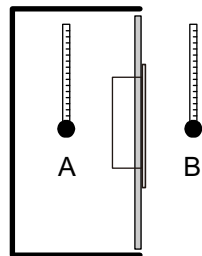

A. Internal temperature

B. External temperature

- Be sure that heat from surrounding equipment does not cause this product to exceed its standard operating temperature.
- When mounting Panel Type in portrait orientation, ensure that the right side of this product faces up. In other words, the power connector should be at the top. For the Box Module, see *Box Module Installation*, page 72.

**NOTE:** Please make sure your applications support portrait orientation of the display.

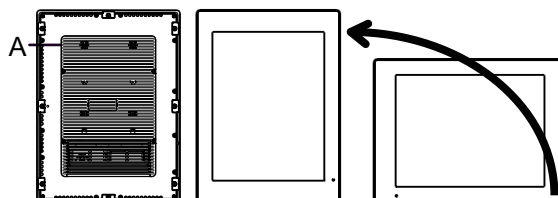

A. Power connector

- When installing this product in a slanted position, the product face should not incline more than 30°.

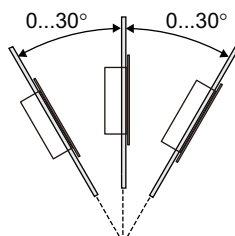

- For easier maintenance, operation and improved ventilation, install this product at least 100 mm (3.94 in) away from adjacent structures and other equipment as shown in the following illustration:

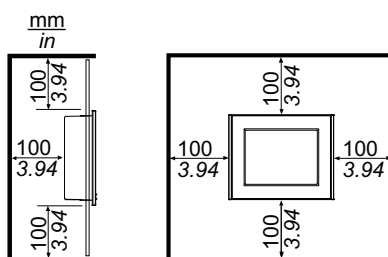

## Pressure Differences

When applying and installing this product, it is important that steps are taken to eliminate any pressure difference between the inside and the outside of the enclosure in which this product is mounted. Higher pressure inside the enclosure can cause delamination of the front membrane of the display. Even a small pressure difference inside the enclosure will act on the large area of the membrane and can result in sufficient force to delaminate the membrane and thus cause failure of the touch capability. Pressure differences can often occur in applications where there are multiple fans and ventilators moving air at different rates in different rooms. Please follow these techniques to ensure that this product's function is not impacted by this mis-application:

1. Seal all conduit connections inside of the enclosure, especially those that lead to other rooms that may be at a different pressure.
2. Where applicable, install a small weep hole at the bottom of the enclosure to allow equalization of the internal and external pressure.

## Box Module Installation

### Introduction

You can use the following methods to install the box module.

- Wall mounting
- Flat mounting
- Book mounting



Each installation method is described below.

**NOTE:**

- Depending on the panel’s material and design, the panel’s installation surface may need to be strengthened. If high levels of vibration are expected and this product’s installation surface can move (such as because of a panel door opening or closing), due consideration should be given to this product’s weight.
- Determine the thickness of the panel in consideration of its material and strength as well as the environment in which this product is used. The thickness must be 1.6 mm (0.06 in) or more, considering the length of M4 screws.
- There is a decal attached to the rear face of the Box Module. Do not remove this decal; otherwise, the Box Module will not function properly.
- When using the following interfaces, be careful when mounting the Box Module by itself with either wall mounting or flat mounting.
  - RS-232C isolated x 2
  - RS-422/485 isolated x 2

If you purchased the Standard Box with the above interface, remove the interface, mount the Box Module to the panel, then re-attach the interface. After purchasing, when attaching the above interface to the Standard Box or to interface slot 2 on the Advanced Box, first mount the Box Module to the panel, then attach the interface.

<b>⚡⚠ DANGER</b>
<p><b>HAZARD OF ELECTRIC SHOCK, EXPLOSION, OR ARC FLASH</b></p> <ul style="list-style-type: none"> <li>• Remove all power from the device before removing any covers or elements of the system, and prior to installing or removing any accessories, hardware, or cables.</li> <li>• Unplug the power cable from both this product and the power supply prior to installing or removing the product.</li> <li>• Always use a properly rated voltage sensing device to confirm power is off where and when indicated.</li> <li>• Replace and secure all covers or elements of the system before applying power to this product.</li> <li>• Use only the specified voltage when operating this product. The DC model is designed to use 24 Vdc, and the AC model is designed to use 100 to 240 Vac. Always check whether your device is DC or AC powered before applying power.</li> <li>• When using this product in Class I, Division 2, Groups A, B, C, and D hazardous locations, install this product in an enclosure that prevents the operator from touching the back of this product without the use of tools.</li> </ul> <p><b>Failure to follow these instructions will result in death or serious injury.</b></p>

<b>⚠ CAUTION</b>
<p><b>RISK OF INJURY</b></p> <ul style="list-style-type: none"> <li>• Hold this product in place after removing the screws.</li> <li>• Use both hands.</li> </ul> <p><b>Failure to follow these instructions can result in injury or equipment damage.</b></p>

**NOTICE****EQUIPMENT DAMAGE**

- Always use the installation gasket.
- Keep this product stabilized while you are installing or removing the screws.

**Failure to follow these instructions can result in equipment damage.**

**NOTICE****BROKEN ENCLOSURE**

Do not exert more torque than the amount specified.

**Failure to follow these instructions can result in equipment damage.**

## Wall Mounting

Install the product to the panel or wall with M4 screws (4 pieces).

**NOTE:**

- The necessary torque is 1.5 N•m (13.3 lb-in).
- With this installation method, the interface side (the bottom of the product) must be facing downward.
- To prevent abnormally high temperatures from occurring inside the product, mount the product completely vertically.
- If the PCI/PCIe slot is connected to Advanced Box, wall mounting requires an optional flat/wall mount adapter. For installation using the flat/wall mount adapter, refer to *Wall mounting when installing PCI/PCIe slot*, page 75.

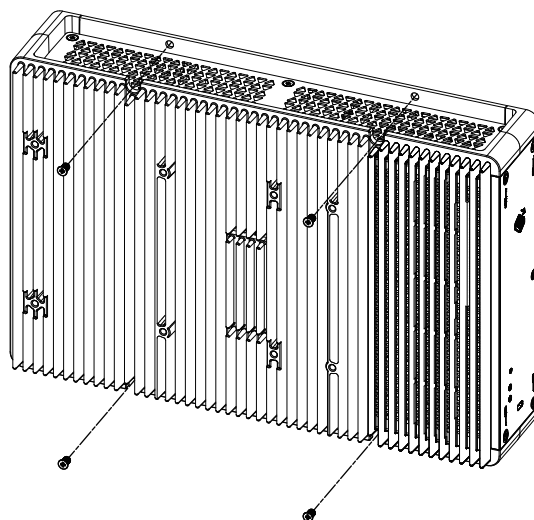

## Flat Mounting

Install the product to the panel or wall with M4 screws (4 pieces).

**NOTE:**

- The necessary torque is 1.5 N•m (13.3 lb-in).
- With this installation method, the heat sink must be facing upward.
- To prevent abnormally high temperatures from occurring inside the product, mount the product completely horizontally.
- If the PCI/PCIe slot is connected to Advanced Box, wall mounting requires an optional flat/wall mount adapter. For installation using the flat/wall mount adapter, refer to *Wall mounting when installing PCI/PCIe slot*, page 75.

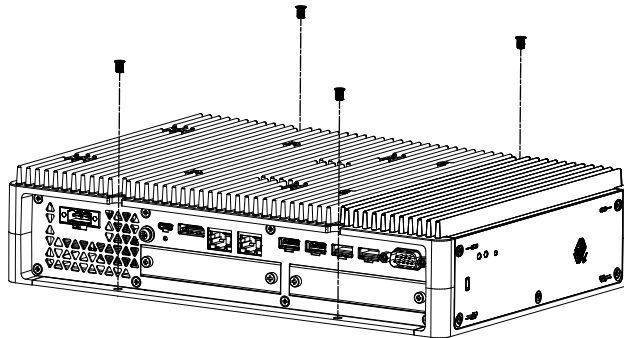

**Wall mounting when installing PCI/PCIe slot**

When the PCI/PCIe slot is connected to Advanced Box, wall mounting requires an optional flat/wall mount adapter.

Flat/wall mount adapter: PFXYP6ADFMA

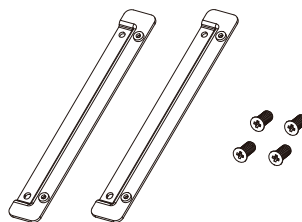

**Installation procedure**

1. Use the screws for the flat/wall mount adapter to attach it to the product.  
(Attach on both the top and bottom of the product.)

**NOTE:**

- The necessary torque is 1.5 N•m (13.3 lb-in).
- For the external dimensions of the Advanced Box with the flat/wall mount adapter, refer to Dimensions with Flat/Wall Mount Adapter, page 53.

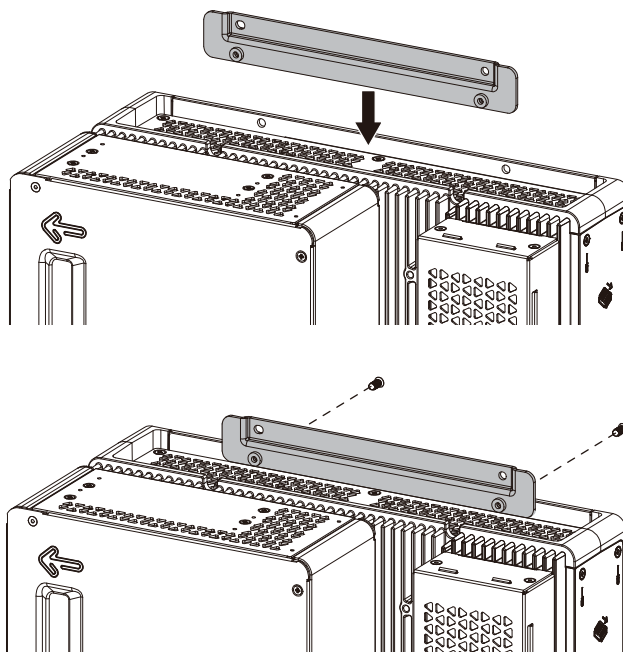

2. Install the product to the panel or wall with M4 screws (4 pieces).

**NOTE:**

- The necessary torque is 1.5 N•m (13.3 lb-in).
- To prevent abnormally high temperatures from occurring inside the product, mount the product completely vertically or horizontally.
- When mounting the product vertically, the interface side (the bottom of the product) must be facing downward.
- When mounting the product horizontally, the heat sink must be facing upward.

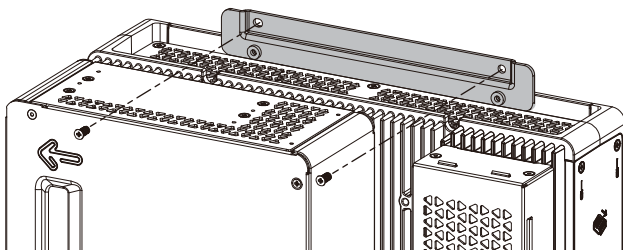

## Book Mounting

Book mounting requires an optional book mount adapter.

Book mount adapter for Advanced Box: PFXYP6ADBMA

Book mount adapter for Standard Box: PFXYP6ADBMS

### Installation procedure

1. When attaching the side of the Box Module to the panel, use A; when attaching the top of the Box Module, use B.

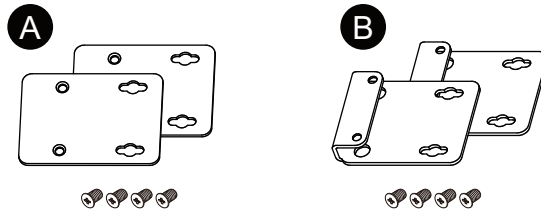

2. Remove the screws attached to the product (4 pieces), then use the screws for the book mount adapter to attach it to the product. When attaching to the top of the product, attach the B book mount adapter so that the protruding part faces the product.

**NOTE:**

- The necessary torque is 0.7 N•m (6.2 lb-in).
- For the external dimensions of the Box Module with the book mount adapter, refer to the following.

Advanced Box:

Dimensions with Book Mount Adapter (Top), page 51

Dimensions with Book Mount Adapter (Side), page 52

Standard Box:

Dimensions with Book Mount Adapter (Top), page 54

Dimensions with Book Mount Adapter (Side), page 54

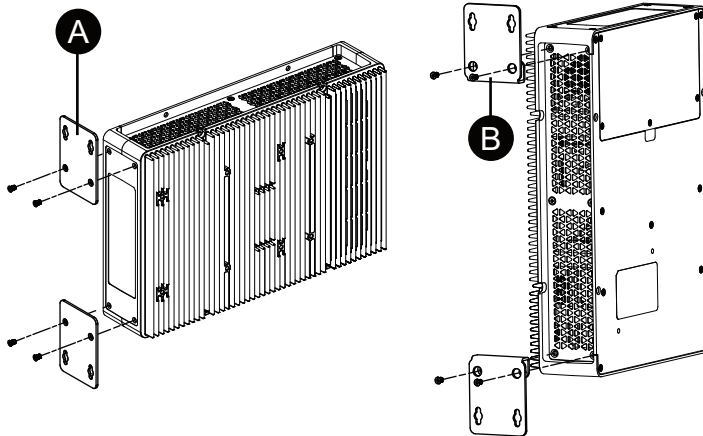

3. Install the product to the panel or wall with M4 screws (4 pieces).

**NOTE:**

- The necessary torque is 1.5 N•m (13.3 lb-in).
- When installing on the side of the product, the interface side (the bottom of the product) must be facing downward.
- When installing on the top of the product, the power connector must be at the top.
- To prevent abnormally high temperatures from occurring inside the product, mount the product completely vertically.

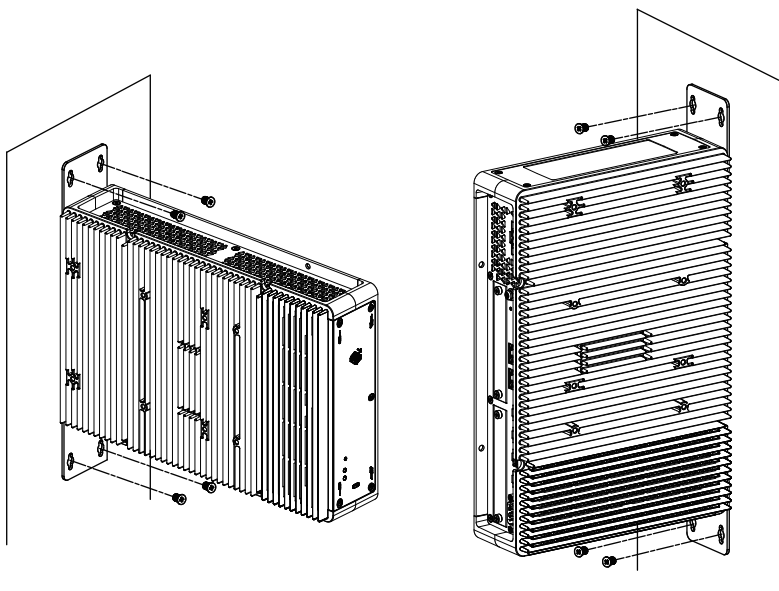

## Panel Type Installation

### Panel Cut Dimensions

Based on the panel cut dimensions, open a mount hole on the panel.

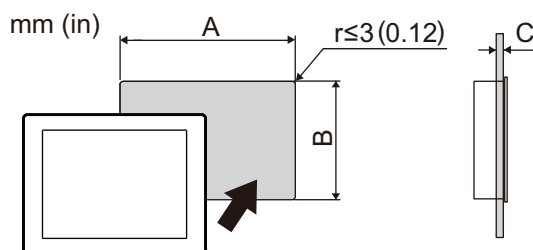

Model Name		
A	B	C
<b>12-inch</b>		
301.5 mm (+1/-0 mm) (11.87 in [+0.04/-0 in])	227.5 mm (+1/-0 mm) (8.96 in [+0.04/-0 in])	1.6...5 mm (0.06...0.2 in)
<b>15-inch</b>		
383.5 mm (+1/-0 mm) (15.1 in [+0.04/-0 in])	282.5 mm (+1/-0 mm) (11.12 in [+0.04/-0 in])	1.6...5 mm (0.06...0.2 in)
<b>10-inch Wide</b>		
255 mm (+1/-0 mm) (10.04 in [+0.04/-0 in])	185 mm (+1/-0 mm) (7.28 in [+0.04/-0 in])	1.6...5 mm (0.06...0.2 in)

Model Name		
A	B	C
<b>12-inch Wide</b>		
295 mm (+1/-0 mm) (11.61 in [+0.04/-0 in])	217 mm (+1/-0 mm) (8.54 in [+0.04/-0 in])	1.6...5 mm (0.06...0.2 in)
<b>15-inch Wide</b>		
394 mm (+1/-0 mm) (15.51 in [+0.04/-0 in])	250 mm (+1/-0 mm) (9.84 in [+0.04/-0 in])	1.6...5 mm (0.06...0.2 in)
<b>19-inch Wide</b>		
449.5 mm (+1/-0 mm) (17.7 in [+0.04/-0 in])	279.5 mm (+1/-0 mm) (11.0 in [+0.04/-0 in])	1.6...5 mm (0.06...0.2 in)
<b>22-inch Wide</b>		
518.5 mm (+1/-0 mm) (20.41 in [+0.04/-0 in])	316.5 mm (+1/-0 mm) (12.46 in [+0.04/-0 in])	1.6...5 mm (0.06...0.2 in)

## Installation Procedure

 **DANGER**

**HAZARD OF ELECTRIC SHOCK, EXPLOSION, OR ARC FLASH**

- Remove all power from the device before removing any covers or elements of the system, and prior to installing or removing any accessories, hardware, or cables.
- Unplug the power cable from both this product and the power supply prior to installing or removing the product.
- Always use a properly rated voltage sensing device to confirm power is off where and when indicated.
- Replace and secure all covers or elements of the system before applying power to this product.
- Use only the specified voltage when operating this product. The DC model is designed to use 24 Vdc, and the AC model is designed to use 100 to 240 Vac. Always check whether your device is DC or AC powered before applying power.
- When using this product in Class I, Division 2, Groups A, B, C, and D hazardous locations, install this product in an enclosure that prevents the operator from touching the back of this product without the use of tools.

**Failure to follow these instructions will result in death or serious injury.**

### NOTICE

**EQUIPMENT DAMAGE**

Keep this product stabilized in the panel cut while you are installing or removing the screw fasteners.

**Failure to follow these instructions can result in equipment damage.**

### NOTICE

**BROKEN ENCLOSURE**

Do not exert more torque than the amount specified.

**Failure to follow these instructions can result in equipment damage.**

1. Check that the gasket is seated securely into the bezel's groove, which runs around the perimeter of the display panel frame.

**NOTE:** Always use the installation gasket, since it absorbs vibration in addition to repelling water. For the procedure on replacing the installation gasket, refer to Replacing the Installation Gasket, page 152.

2. Based on the Panel Cut Dimensions, page 78, open a mount-hole on the panel and attach the Panel Type to the panel from the front side.

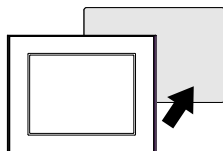

3. Confirm that the anti-drop lock on the top of the Panel Type is attached to the panel.

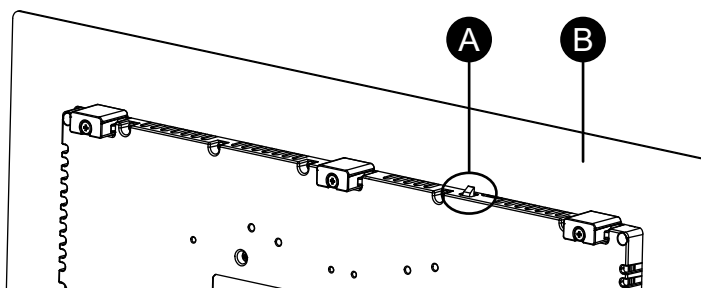

- A. Anti-drop lock
- B. Panel

4. Insert the installation fasteners into the bracket openings at the top, bottom, left and right, and use a screwdriver to tighten the screws little by little, alternating between diagonally-positioned screws.

**NOTE:** The necessary torque is 0.7 N•m (6.2 lb-in).

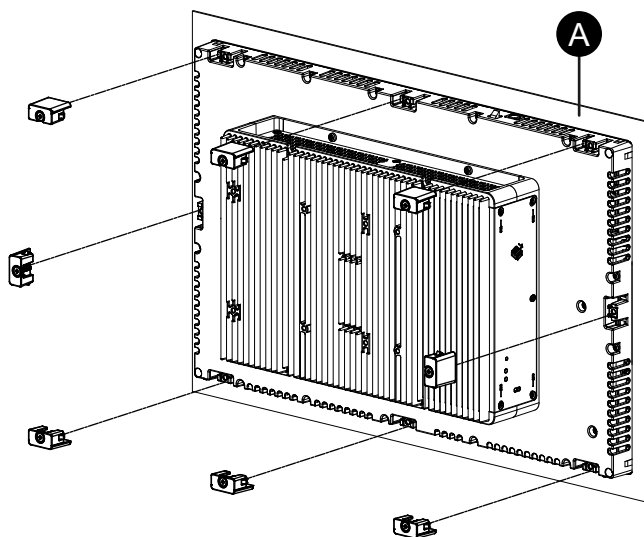

- A. Panel

The number of installation fasteners for each Panel Type is as follows.

12-inch, 10-inch Wide, 12-inch Wide	Top - 2, Bottom - 2
15-inch, 15-inch Wide, 19-inch Wide, 22-inch Wide	Top - 3, Bottom - 3, Left - 1, Right - 1



## Removal Procedure

### **DANGER**

#### **HAZARD OF ELECTRIC SHOCK, EXPLOSION, OR ARC FLASH**

- Remove all power from the device before removing any covers or elements of the system, and prior to installing or removing any accessories, hardware, or cables.
- Unplug the power cable from both this product and the power supply prior to installing or removing the product.
- Always use a properly rated voltage sensing device to confirm power is off where and when indicated.
- Replace and secure all covers or elements of the system before applying power to this product.
- Use only the specified voltage when operating this product. The DC model is designed to use 24 Vdc, and the AC model is designed to use 100 to 240 Vac. Always check whether your device is DC or AC powered before applying power.

**Failure to follow these instructions will result in death or serious injury.**

### **CAUTION**

#### **RISK OF INJURY**

Do not drop this product when you remove it from the panel.

- Hold this product in place after removing the fasteners.
- Use both hands.
- While pushing on the anti-drop lock, be careful not to hurt your fingers.

**Failure to follow these instructions can result in injury or equipment damage.**

### **NOTICE**

#### **EQUIPMENT DAMAGE**

Keep this product stabilized in the panel cut while you are installing or removing the screw fasteners.

**Failure to follow these instructions can result in equipment damage.**

### **NOTICE**

#### **EQUIPMENT DAMAGE**

Remove this product while pushing the anti-drop lock or by making sure the lock does not touch the panel.

**Failure to follow these instructions can result in equipment damage.**

1. Using a screwdriver, gradually loosen the screws for the fasteners (top, bottom, left, and right), alternating diagonally between screws until all screws are loose.

**NOTE:** For the number of installation fasteners on your model, see Number of Installation Fasteners in step 4 of Installation Procedure, page 79.

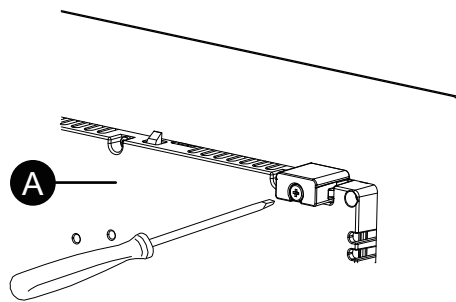

A. Rear side

2. While pushing on the anti-drop lock on the top of the Panel Type, slowly remove the Panel Type from the panel.

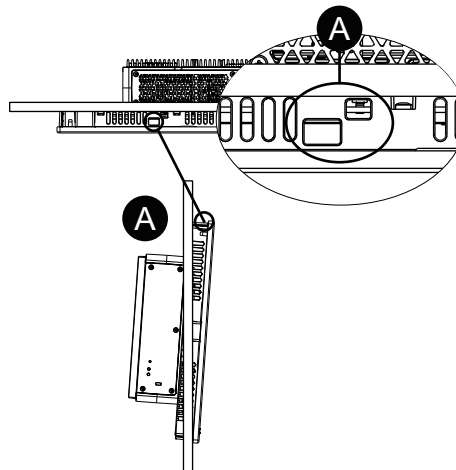

A. Anti-drop lock

# Wiring the Power Supply

## AC/DC Power Cord Preparation

### **⚠️⚠️ DANGER**

**HAZARD OF ELECTRIC SHOCK, EXPLOSION, OR ARC FLASH**

- Remove all power from the device before removing any covers or elements of the system, and prior to installing or removing any accessories, hardware, or cables.
- Remove power before wiring this product’s power terminals.
- Always use a properly rated voltage sensing device to confirm power is off where and when indicated.
- Replace and secure all covers or elements of the system before applying power to this product.
- Use only the specified voltage when operating this product. The DC model is designed to use 24 Vdc, and the AC model is designed to use 100 to 240 Vac. Always check whether your device is DC or AC powered before applying power.
- Since this product is not equipped with a power switch, be sure to connect a power switch to the power supply.
- Be sure to ground this product’s FG/PE terminal.

**Failure to follow these instructions will result in death or serious injury.**

**NOTE:**

- The SG (signal ground) and FG (frame ground) terminals are connected internally in this product.
- When the FG/PE terminal is connected, be sure the wire is grounded. Not grounding this product can result in excessive electromagnetic interference (EMI).
- Make sure the ground wire is either the same or heavier gauge than the power wires.
- Do not use aluminum wires in the power supply's power cord.
- To prevent the possibility of a terminal short, use a pin terminal that has an insulating sleeve.
- If the ends of the individual wires are not twisted correctly, the wires may create a short circuit.
- The conductor type is solid or stranded wire.
- Use copper wire rated for 75 °C (167 °F) or higher.
- For AC input, use a maximum 20 A branch circuit protective device.
- AC models obtain UL certification for use in environments rated at Overvoltage Category II or lower.
- Use the SELV (Safety Extra-Low Voltage) circuit and LIM (Limited Energy) circuit for DC input.

AC/DC power cord	
Recommended cross section	0.75...3.5 mm <sup>2</sup> (18...12 AWG)* <sup>1</sup>
Conductor type	Solid or stranded wire* <sup>2</sup>

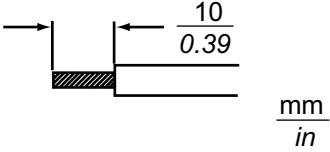
AC/DC power cord	
Conductor length	
Recommended driver* <sup>3</sup>	SZS 0.6x3.5 (1205053)
Recommended pin terminals* <sup>3</sup>	3201288 AI 0,75-10 GY 3200182 AI 1 -10 RD 3200195 AI 1,5 -10 BK 3202533 AI 2,5 -10 BU
Recommended pin terminal crimp tool* <sup>3</sup>	CRIMPFOX 6

\*1 Since a high level of current flows in the DC model, thick wires are recommended to minimize voltage drops due to wiring.

\*2 When using stranded wires, confirm the level of current supported by the wire.

\*3 Items are manufactured by Phoenix Contact.

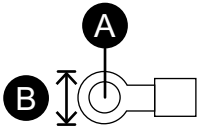
AC grounding wire	
Recommended cross section	2 mm <sup>2</sup> or more (14 AWG or greater)
Ring terminal size* <sup>1</sup>	 <p>A. <math>\Phi 4.3</math> mm (0.17 in) or more B. 7.2 mm (0.28 in) or less</p>
Recommended ring terminal* <sup>2</sup>	V2-P4 V5.5-S4

\*1 To prevent a short circuit caused by loose screws, use a crimp-type terminal with an insulating sleeve.

\*2 Items are manufactured by J.S.T Mfg. Co., Ltd.

## Connecting the AC Power Cord

### AC Power Connector: Spring Clamp Terminal Blocks

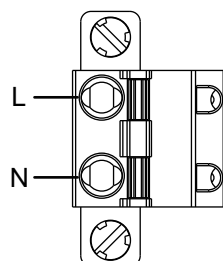

Connection	Wire
L	Live
N	Neutral

### How to Connect the AC Power Cord

- Loosen the screw on the product's PE terminal, connect the grounding wire, and tighten the screw.

**NOTE:**

- The necessary torque is 1.5 N•m (13.3 lb-in).
- If the wire is not connected to the PE terminal properly, touch may not respond normally.

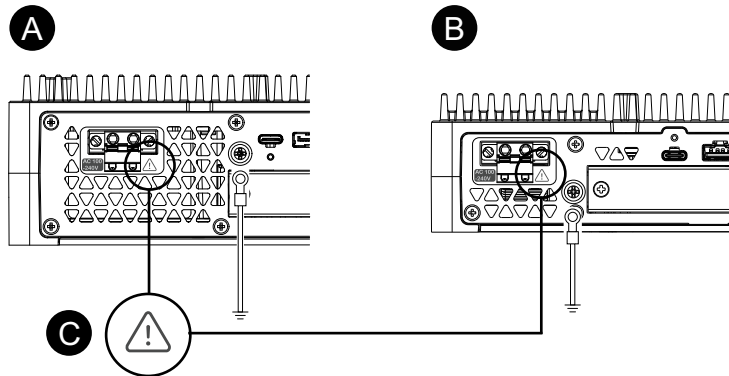

- A. Advanced Box
- B. Standard Box
- C. This mark indicates that you must use copper wire rated for 75 °C (167 °F) or higher.

- Confirm the power cord is not connected to the power supply.
- Crimp a pin terminal properly to the end of each power cable wire.
- Push the opening button with a small and flat screwdriver to open the desired pin hole.
- Insert each power cord wire into its corresponding hole. Release the opening button to clamp the wire in place.

**NOTE:**

- When using stranded wire, do not short with neighboring wires.
- When connecting with stranded wires, do not solder the stranded wires.

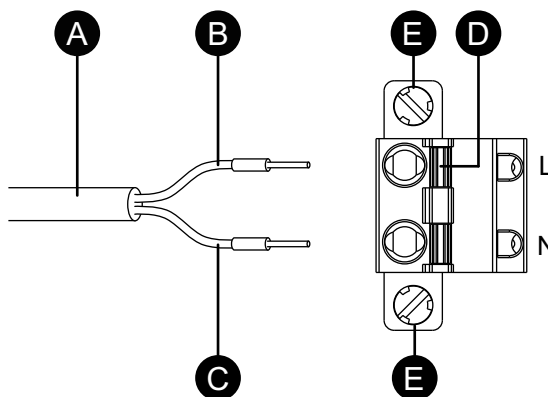

- A. Power cord
- B. Black
- C. White
- D. Opening button
- E. Screw

- After inserting all two power cord wires, insert the AC power connector into the power connector on this product.

7. Affix the screws on both sides of the connector.

**NOTE:** The necessary torque is 0.5 N•m (4.4 lb-in).

## Connecting the DC Power Cord

### DC Power Connector: Spring Clamp Terminal Blocks

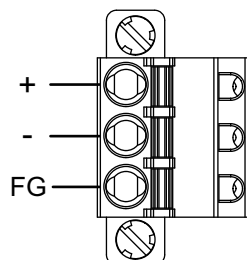

Connection	Wire
+	24 Vdc
-	0 Vdc
FG	Grounded terminal connection to the panel chassis.

### How to connect the DC Power Cord

1. Confirm the power cord is not connected to the power supply.
2. Crimp a pin terminal properly to the end of each power cable wire.
3. Push the opening button with a small and flat screwdriver to open the desired pin hole.
4. Insert each power cord wire into its corresponding hole. Release the opening button to clamp the wire in place.

**NOTE:**

- When using stranded wire, do not short with neighboring wires.
- When connecting with stranded wires, do not solder the stranded wires.
- If the wire is not inserted into the FG terminal properly, touch may not respond normally.
- Using the PE terminal is unnecessary.

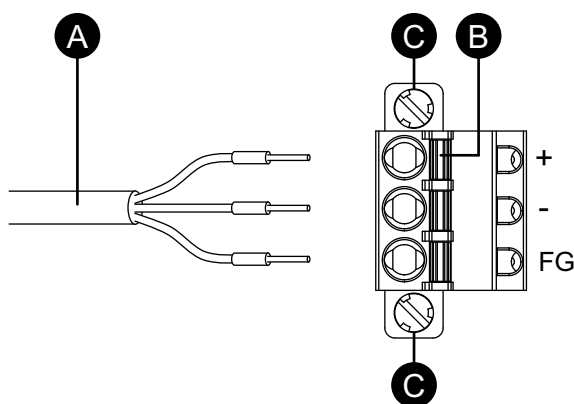

- A. Power cord  
 B. Opening button  
 C. Screw

5. After inserting all three power cord wires, insert the DC power connector into the power connector on this product.
6. Affix the screws on both sides of the connector.

**NOTE:** The necessary torque is 0.5 N•m (4.4 lb-in).

### Power Supply Precautions

⚠ **DANGER**

**SHORT CIRCUIT, FIRE, OR UNINTENDED EQUIPMENT OPERATION**

- Install and fasten this product in an installation panel or cabinet prior to connecting power supply and communication lines.
- Securely attach power cables to an installation panel or cabinet.
- Avoid excessive force on the power cable.

**Failure to follow these instructions will result in death or serious injury.**

### Improving Noise/Surge Resistance

- This product's power cord should not be bundled with or kept close to main circuit lines (high voltage, high current), power lines, or input/output lines, and their various systems should be kept separate. When power lines cannot be wired via a separate system, use shielded cables for input/output lines.
- Make the power cord as short as possible, and be sure to twist the ends of the wires together (i.e. twisted pair cabling) from close to the power supply unit.
- If there is an excess amount of noise on the power supply line, connect a noise reducing transformer, noise filter, or other before turning on the power.
- Connect a surge protection device to handle power surges.
- To increase noise resistance, attach a ferrite core to the power cable.

### Power Supply Connections

- When supplying power to this product, connect the power as shown below.

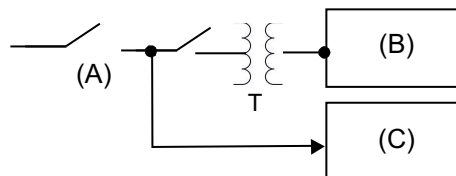
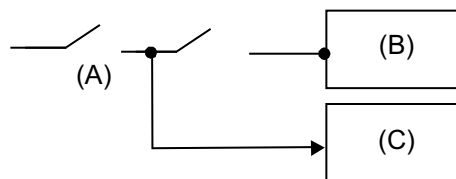

- A. Main power
- B. This product
- C. Other unit

- The following shows a surge protection device connection:

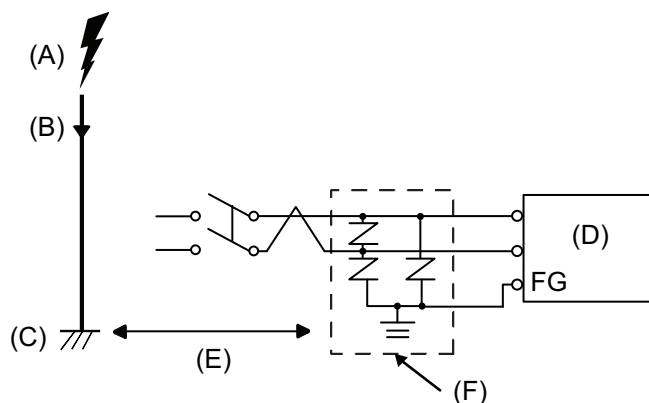

- A. Lightning
- B. Lightning rod
- C. Ground
- D. This product
- E. Provide adequate distance
- F. Surge protection device

- Attach a surge protection device to prevent damage to this product as a result of a lightning induced power surge from a large electromagnetic field generated from a direct lightning strike.

We also strongly recommend to connect the crossover grounding wire of this product to a position close to the ground terminal of the surge protection device.

It is expected that there will be an effect on this product due to fluctuations in grounding potential when there is a large surge flow of electrical energy to the lightning rod ground at the time of a lightning strike. Provide adequate distance between the lightning rod grounding point and the surge protection device grounding point.

- If the voltage variation is outside the prescribed range, connect a regulated power supply.

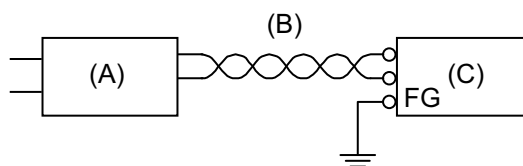

- A. Regulated power supply
- B. Twisted-pair cord
- C. This product

- Select a power supply low in noise for between the line and ground. If there is an excessive amount of noise, connect an insulating transformer. Use insulating transformers with capacities exceeding the maximum power consumption, including that of the Box Module. Refer to *Electrical Specifications*, page 29.



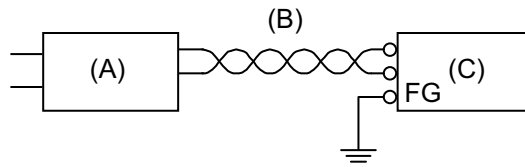

- A. Insulating transformer
- B. Twisted-pair cord
- C. This product

## Grounding

### Independent Grounding

Always ground the FG/PE terminal. Be sure to separate this product from the FG/PE of other devices as shown below.

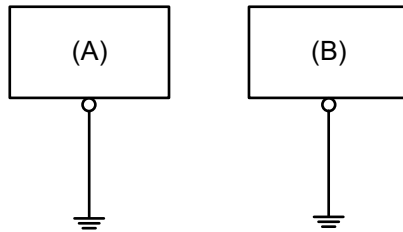

- A. This product
- B. Other equipment

### Precautions

- Check that the grounding resistance is 100 Ω or less.\*1
- The FG/PE wire should have a cross sectional area 2 mm<sup>2</sup> (AWG 14) or greater\*1. Create the connection point as close to this product as possible, and make the wire as short as possible. When using a long grounding wire, replace the thin wire with a thicker wire, and place it in a duct.
- The SG (signal ground) and FG (frame ground) terminals are connected internally in this product. When connecting the SG line to another device, be sure that no ground loop is formed.

\*1 Observe local codes and standards.

## Common Grounding

Electromagnetic Interference (EMI) can be created if devices are improperly grounded. EMI can cause loss of communication. If independent grounding is not possible, use a common grounding point as shown in the configuration below. Do not use any other configuration for common grounding.

Correct grounding

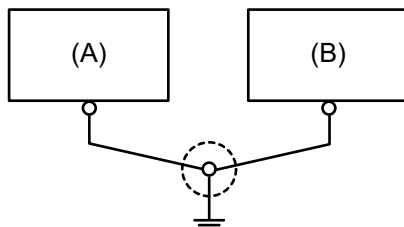

- A. This product
- B. Other equipment

Incorrect grounding

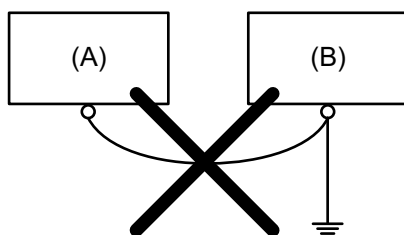

- A. This product
- B. Other equipment

## Storage Installation

### HDD/SSD Installation

You can install 2 HDD or SSD to the Advanced Box, and 1 HDD or SSD to the Standard Box.

**⚠ ⚠ DANGER**

**HAZARD OF ELECTRIC SHOCK, EXPLOSION, OR ARC FLASH**

- Remove all power from the device before removing any covers or elements of the system, and prior to installing or removing any accessories, hardware, or cables.
- Unplug the power cable from both this product and the power supply.
- Always use a properly rated voltage sensing device to confirm power is off where and when indicated.
- Replace and secure all covers or elements of the system before applying power to this product.
- Use only the specified voltage when operating this product. The DC model is designed to use 24 Vdc, and the AC model is designed to use 100 to 240 Vac. Always check whether your device is DC or AC powered before applying power.

**Failure to follow these instructions will result in death or serious injury.**

**⚠ CAUTION**

**STORAGE DEVICE DAMAGE AND DATA LOSS**

- Remove all power before making any contact with an installed storage device.
- Use only our optional storage devices for this product.
- Make sure you regularly back up the data.
- Confirm the storage device is correctly oriented before insertion.
- Do not bend, drop, or strike the storage device.
- Do not touch the storage device connectors.
- Do not disassemble or modify the storage device.
- Keep the storage device dry.

**Failure to follow these instructions can result in injury or equipment damage.**

**⚠ CAUTION**

**EXCESSIVE VIBRATION**

Protect the HDD from vibration and impact when installing or removing it.

**Failure to follow these instructions can result in injury or equipment damage.**

**NOTICE**

**ELECTROSTATIC DISCHARGE**

Take the necessary protective measures against electrostatic discharge before attempting to remove the cover.

**Failure to follow these instructions can result in equipment damage.**

**NOTICE**

**BROKEN ENCLOSURE**

Do not exert more torque than the amount specified.

**Failure to follow these instructions can result in equipment damage.**

1. Disconnect the power supply from the Box Module.

2. Touch the housing or ground connection (not the power supply) to discharge any electrostatic charge from your body.
3. Remove 5 screws of the maintenance hatch cover and slide the cover to remove.

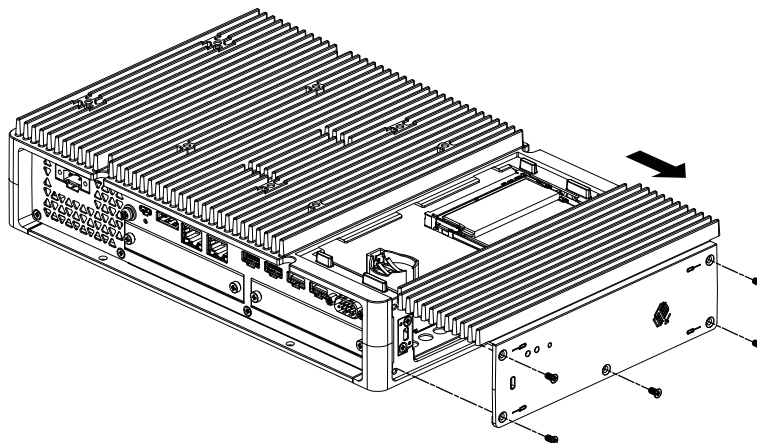

4. Insert the HDD or SSD into the slot.  
Advanced Box: 2 slots (refer to the following)  
Standard Box: 1 slot

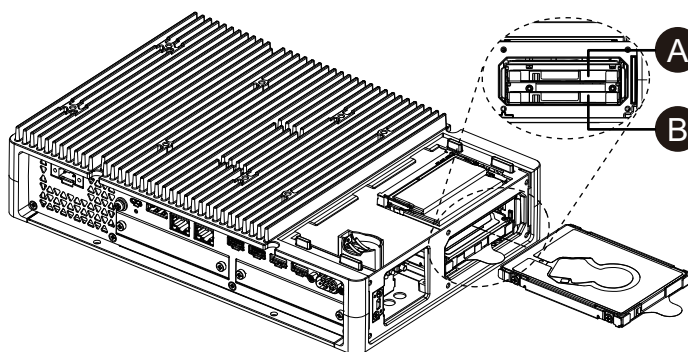

- A. Disk 2
- B. Disk 1

5. When removing the HDD or SSD, pull the tab.

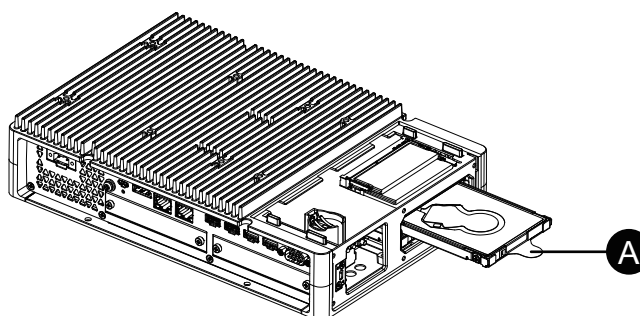

- A. Tab

6. Replace the maintenance hatch cover and tighten the screws.

**NOTE:** The necessary torque is 0.3 N•m (2.7 lb-in).

## M.2 SSD Installation

The following describes how to install the M.2 SSD card. The size of the M.2 SSD card conforms to Type 2242. M.2 SSD becomes Disk 0.

When installing the M.2 SSD, the optional M.2 cooling kit is required. Purchase and install using the following steps.

M.2 cooling kit for Advanced Box: PFXYP6HSM2A\*1

M.2 cooling kit for Standard Box: PFXYP6HSM2S

\*1 If you use the Advanced Box with the FAN kit, the M.2 cooling kit is unnecessary.

**M.2 Cooling Kit Package Contents**

For Advanced Box:

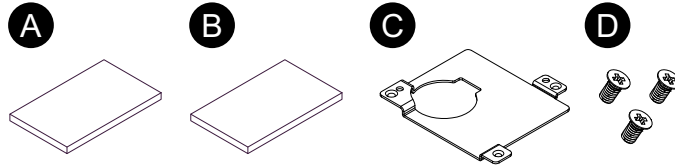

For Standard Box:

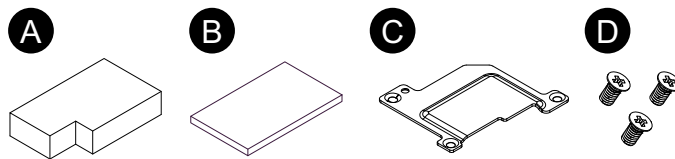

- A. Heat sink pad (for bottom)
- B. Heat sink pad (for top)
- C. Heat sink
- D. Screws for heat sink

**⚠️ ⚠️ DANGER**

**HAZARD OF ELECTRIC SHOCK, EXPLOSION, OR ARC FLASH**

- Remove all power from the device before removing any covers or elements of the system, and prior to installing or removing any accessories, hardware, or cables.
- Unplug the power cable from both this product and the power supply.
- Always use a properly rated voltage sensing device to confirm power is off where and when indicated.
- Replace and secure all covers or elements of the system before applying power to this product.
- Use only the specified voltage when operating this product. The DC model is designed to use 24 Vdc, and the AC model is designed to use 100 to 240 Vac. Always check whether your device is DC or AC powered before applying power.

**Failure to follow these instructions will result in death or serious injury.**

## ▲ CAUTION

### STORAGE DEVICE DAMAGE AND DATA LOSS

- Remove all power before making any contact with an installed storage device.
- Use only our optional storage devices for this product.
- Make sure you regularly back up the data since storage devices have a life span and accidental data loss can occur at any time.
- Confirm the storage device is correctly oriented before insertion.
- Do not bend, drop, or strike the storage device.
- Do not touch inside the storage device or its connectors.
- Do not disassemble or modify the storage device.
- Keep the storage device dry.

**Failure to follow these instructions can result in injury or equipment damage.**

## NOTICE

### ELECTROSTATIC DISCHARGE

Take the necessary protective measures against electrostatic discharge before attempting to remove the cover.

**Failure to follow these instructions can result in equipment damage.**

## NOTICE

### BROKEN ENCLOSURE

Do not exert more torque than the amount specified.

**Failure to follow these instructions can result in equipment damage.**

1. Disconnect the power supply from the Box Module.
2. Touch the housing or ground connection (not the power supply) to discharge any electrostatic charge from your body.
3. Remove 5 screws of the maintenance hatch cover and slide the cover to remove.

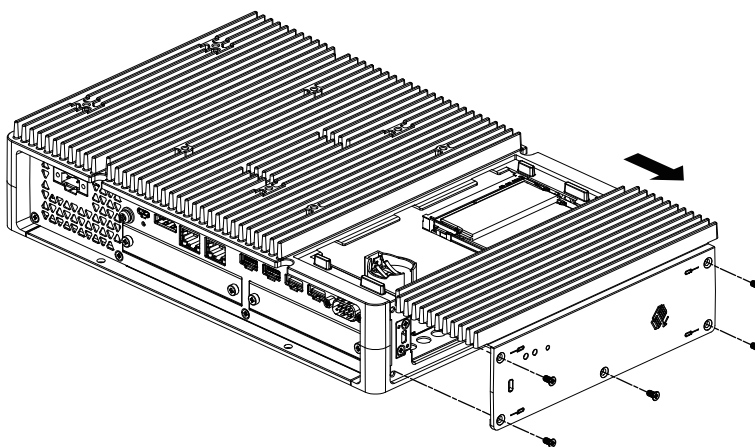

4. Peel off the protective film from the underside of the bottom heat sink pad, and place in the M.2 SSD card installation area. Also peel off the protective film from the top surface of the heat sink pad. When using the Advanced Box with the FAN kit, this step is unnecessary.

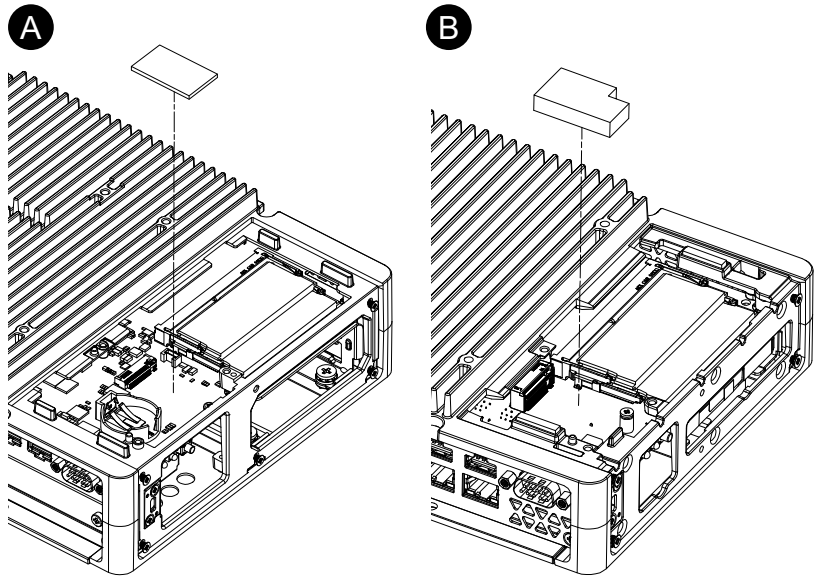

- A. Advanced Box
- B. Standard Box

5. Remove the screw from the M.2 SSD card installation area on the product.

**NOTE:** Using a Phillips screwdriver #1 is recommended.

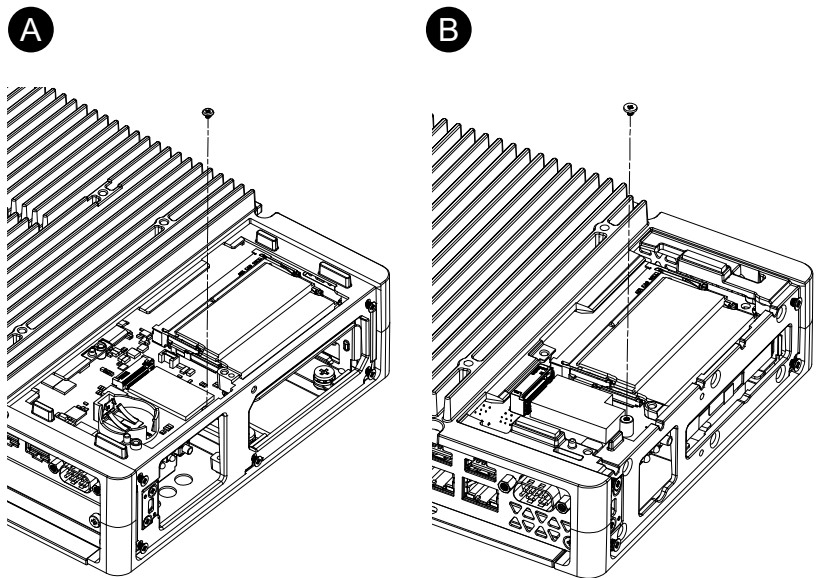

- A. Advanced Box
- B. Standard Box

6. As shown below, insert the M.2 SSD card diagonally, then push from above.

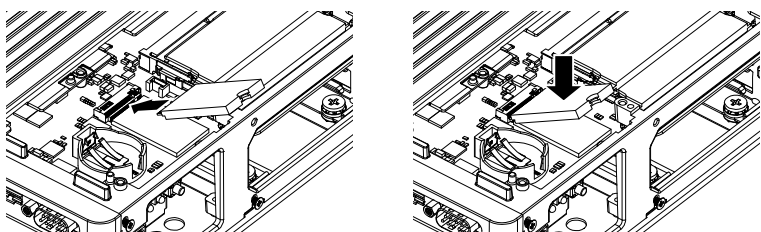

- Secure the M.2 SSD card with the screw removed in step 5.

**NOTE:**

- Using a Phillips screwdriver #1 is recommended.
- The necessary torque is 0.2 N•m (1.77 lb-in).

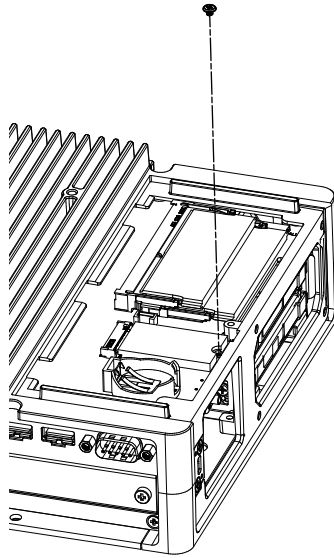

- Peel off the protective film from the underside of the upper heat sink pad, and place the heat sink pad on the M.2 SSD card. Also peel off the protective film from the top surface of the heat sink pad. When using the Advanced Box with the FAN kit, this step is unnecessary.

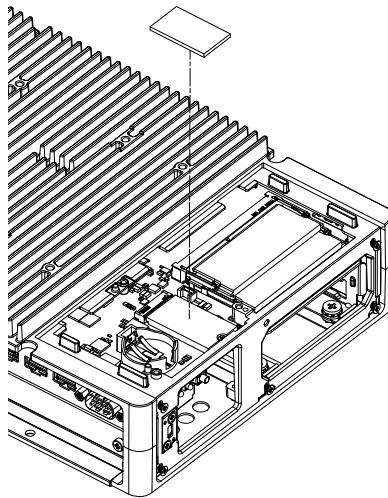



9. Put in the heat sink, and attach with screws.  
When using the Advanced Box with the FAN kit, this step is unnecessary.

**NOTE:** The necessary torque is 0.3 N•m (2.7 lb-in).

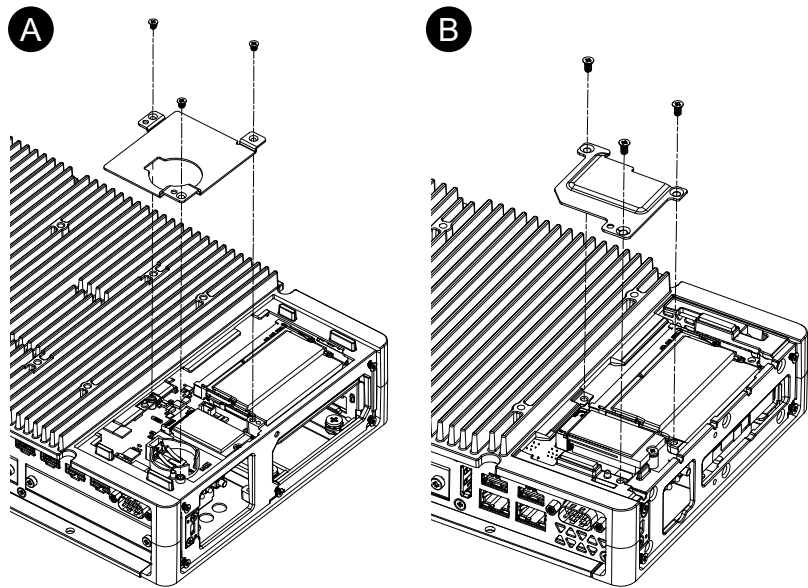

- A. Advanced Box
- B. Standard Box

10. Replace the maintenance hatch cover and tighten the screws.

**NOTE:** The necessary torque is 0.3 N•m (2.7 lb-in).

## Expansion Slot Installation

### PCI/PCIe Card Installation

When using the Advanced Box with PCI/PCIe slots attached, you can install commercially available PCI add-on cards or PCI Express add-on cards (PCI/PCIe cards). You can install PCI/PCIe cards with the following configuration.

	Slot 1	Slot 2
PCI x 1 + PCIe x 1	PCI	PCIe
PCIe x 2	PCIe1	PCIe2
PCI x 2	PCI1	PCI2

**NOTE:** The total power consumption of PCI/PCIe cards can be up to 12 W, regardless of whether one or two cards are installed.

#### PCI/PCIe card dimensions

The maximum size of PCI/PCIe cards that can be installed are as follows.

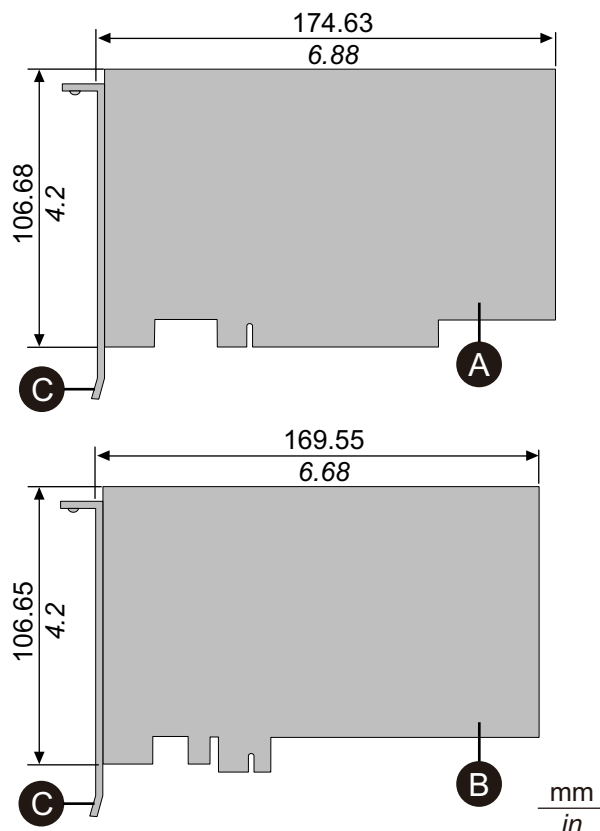

- A. PCI add-on card (short length)
- B. PCI Express add-on card (half length)
- C. I/O bracket

#### Installation procedure

### **⚡⚠ DANGER**

#### **HAZARD OF ELECTRIC SHOCK, EXPLOSION, OR ARC FLASH**

- Remove all power from the device before removing any covers or elements of the system, and prior to installing or removing any accessories, hardware, or cables.
- Unplug the power cable from both this product and the power supply.
- Always use a properly rated voltage sensing device to confirm power is off where and when indicated.
- Replace and secure all covers or elements of the system before applying power to this product.
- Use only the specified voltage when operating this product. The DC model is designed to use 24 Vdc, and the AC model is designed to use 100 to 240 Vac. Always check whether your device is DC or AC powered before applying power.

**Failure to follow these instructions will result in death or serious injury.**

### **NOTICE**

#### **ELECTROSTATIC DISCHARGE**

Take the necessary protective measures against electrostatic discharge before attempting to remove the cover.

**Failure to follow these instructions can result in equipment damage.**

## **NOTICE**

### **BROKEN ENCLOSURE**

Do not exert more torque than the amount specified.

**Failure to follow these instructions can result in equipment damage.**

1. Disconnect the power supply from the Box Module.
2. Touch the housing or ground connection (not the power supply) to discharge any electrostatic charge from your body.
3. Remove the screws (4 pieces) of the PCI/PCIe slot cover.

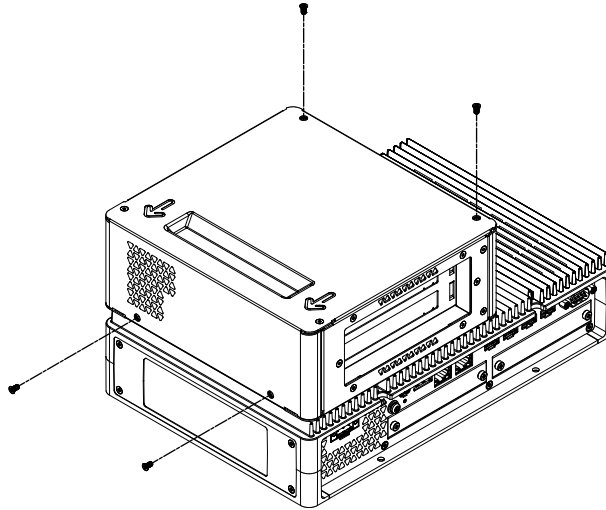

4. Slide the cover in the direction of the arrow on the top of the cover, and remove it.

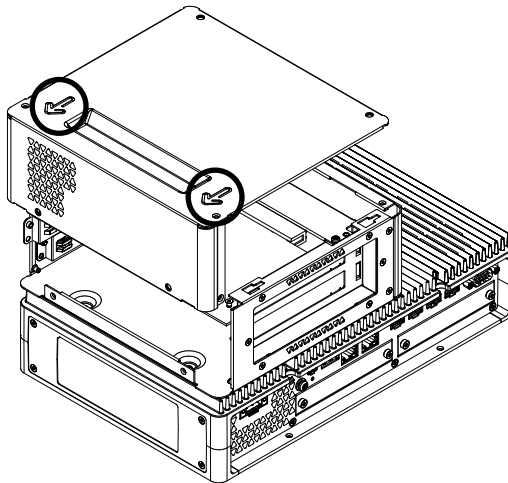

5. Remove the screw from the interface cover, then remove the cover.

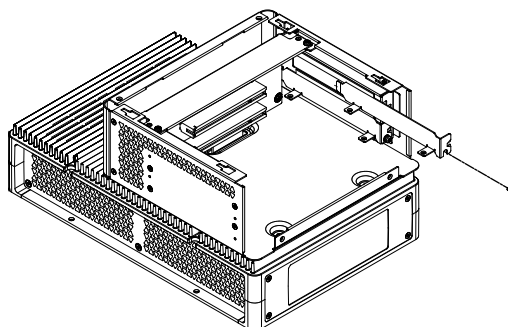

6. Insert the PCI/PCIe card, and secure the card with the screw removed in step 5.

**NOTE:** The necessary torque is 0.3 N•m (2.7 lb-in).

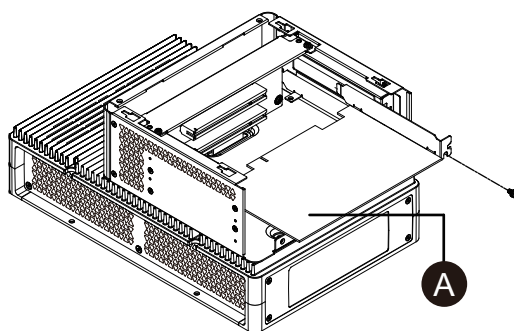

A. PCI/PCIe card

7. Replace the PCI/PCIe slot cover and tighten the screws.

**NOTE:** The necessary torque is 0.3 N•m (2.7 lb-in).

## Memory Installation

### DIMM Installation

#### **⚠️⚠️ DANGER**

##### **HAZARD OF ELECTRIC SHOCK, EXPLOSION, OR ARC FLASH**

- Remove all power from the device before removing any covers or elements of the system, and prior to installing or removing any accessories, hardware, or cables.
- Unplug the power cable from both this product and the power supply.
- Always use a properly rated voltage sensing device to confirm power is off where and when indicated.
- Replace and secure all covers or elements of the system before applying power to this product.
- Use only the specified voltage when operating this product. The DC model is designed to use 24 Vdc, and the AC model is designed to use 100 to 240 Vac. Always check whether your device is DC or AC powered before applying power.

**Failure to follow these instructions will result in death or serious injury.**

#### **⚠️ CAUTION**

##### **MEMORY MODULE DAMAGE AND DATA LOSS**

- Remove all power before making any contact with an installed memory module.
- Use only our optional memory modules for this product.
- Confirm the memory module is correctly oriented before insertion.
- Do not bend, drop, or strike the memory module.
- Do not touch inside the memory module or its connectors.
- Do not disassemble or modify the memory module.
- Keep the memory module dry.

**Failure to follow these instructions can result in injury or equipment damage.**

**NOTICE****ELECTROSTATIC DISCHARGE**

Take the necessary protective measures against electrostatic discharge before attempting to remove the cover.

**Failure to follow these instructions can result in equipment damage.**

**NOTICE****BROKEN ENCLOSURE**

Do not exert more torque than the amount specified.

**Failure to follow these instructions can result in equipment damage.**

1. Disconnect the power supply from the Box Module.
2. Touch the housing or ground connection (not the power supply) to discharge any electrostatic charge from your body.
3. Remove 5 screws of the maintenance hatch cover and slide the cover to remove.

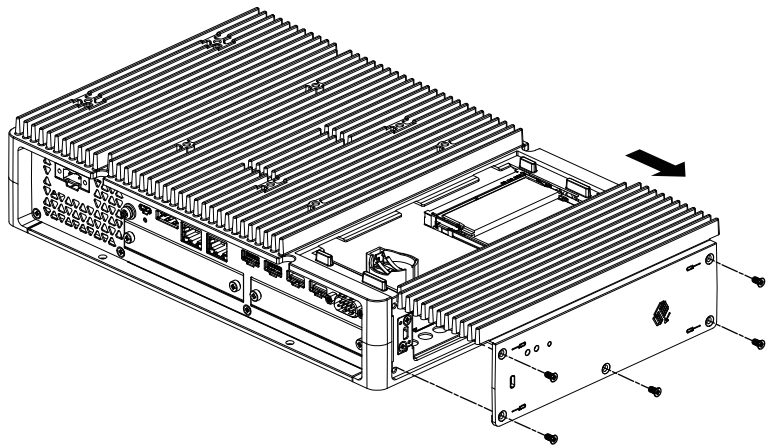

4. As shown below, insert the DIMM module diagonally, then push from above.

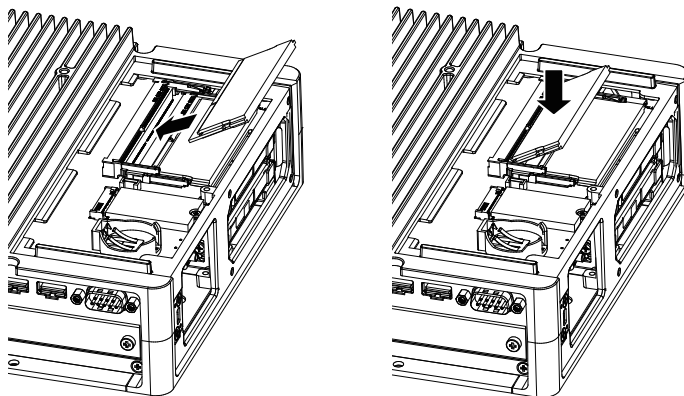

5. Replace the maintenance hatch cover and tighten the screws.

**NOTE:** The necessary torque is 0.3 N•m (2.7 lb-in).

# Optional Interface Installation

## Common Installation Procedure

### Introduction

As an option, you can install a cartridge interface to this product. You can install two slots on the Advanced Box, and one slot on the Standard Box. This section explains how to attach an optional interface to the Box Module.

Some optional interfaces require more than just inserting to the product. For more information, check the pages for each optional interface.

### Installation

#### **DANGER**

##### **HAZARD OF ELECTRIC SHOCK, EXPLOSION, OR ARC FLASH**

- Remove all power from the device before removing any covers or elements of the system, and prior to installing or removing any accessories, hardware, or cables.
- Unplug the power cable from both this product and the power supply.
- Always use a properly rated voltage sensing device to confirm power is off where and when indicated.
- Replace and secure all covers or elements of the system before applying power to this product.
- Use only the specified voltage when operating this product. The DC model is designed to use 24 Vdc, and the AC model is designed to use 100 to 240 Vac. Always check whether your device is DC or AC powered before applying power.

**Failure to follow these instructions will result in death or serious injury.**

#### **NOTICE**

##### **ELECTROSTATIC DISCHARGE**

Take the necessary protective measures against electrostatic discharge before attempting to remove the cover.

**Failure to follow these instructions can result in equipment damage.**

#### **NOTICE**

##### **BROKEN ENCLOSURE**

Do not exert more torque than the amount specified.

**Failure to follow these instructions can result in equipment damage.**

**NOTE:** When using the following interfaces, be careful when mounting the Box Module by itself with either wall mounting or flat mounting.

- RS-232C isolated x 2
- RS-422/485 isolated x 2

If you purchased the Standard Box with the above interface, remove the interface, mount the Box Module to the panel, then re-attach the interface. After purchasing, when attaching the above interface to the Standard Box or to interface slot 2 on the Advanced Box, first mount the Box Module to the panel, then attach the interface.

1. Disconnect the power supply from the Box Module.
2. Touch the housing or ground connection (not the power supply) to discharge any electrostatic charge from your body.

- Remove the screws of the optional interface cover and remove the cover.

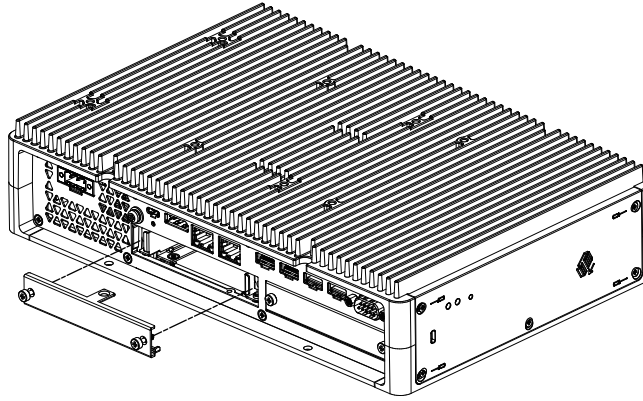

- With the side labelled “UP” facing upward, insert the optional interface into the Box Module and tighten the screws.

**NOTE:** The necessary torque is 0.3 N•m (2.7 lb-in).

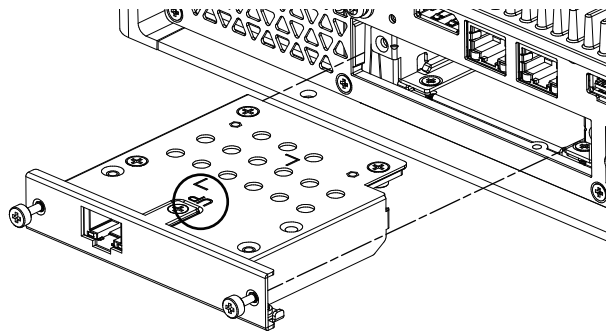

## Before Using Serial Interface Options

The following are some notes on using the serial interface options below.

- RS-232C isolated x 2
- RS-232C x 4
- RS-422/485 isolated x 2

With serial interface options, because of the option's internal structure, COM port numbers are assigned that currently do not physically exist. Before using a serial interface option, review the following notes on COM port numbers.

### Caution on Installation:

When attaching serial interface options to both open slots on the Advanced Box or Advanced Model, attach to Slot 1 first. Refer to *Parts Identification and Functions*, page 23.

### About COM port numbers:

The serial port on the Box Module is assigned as COM1, and the COM2 port is reserved. As a result, COM port numbers for serial interface options start from COM3.

Also, even a serial interface option with 2 physical ports has 4 ports internally.

### About RS-232C isolated x 2 and RS-422 x 2:

After mounting to the body, from the left the ports are COM3 and COM4. As mentioned above, there are 4 ports internally so COM5 and COM6 also exist. However, you cannot use COM5 and COM6 even though they appear in the Windows® Device Manager and other applications.

**NOTE:** For RS-422 x 2, make sure you review its port installation procedure. Refer to RS-422/485 isolated x 2, page 108.

**About RS-485 x 2:**

After mounting to the body, from the left the ports are COM5 and COM6. As mentioned above, there are 4 ports internally so COM3 and COM4 also exist. However, you cannot use COM3 and COM4 even though they appear in the Windows® Device Manager and other applications.

**NOTE:** For RS-485 x 2, make sure you review its port installation procedure. Refer to RS-422/485 isolated x 2, page 108.

**About RS-232C x 4:**

At the end of the cables, RS-232C ports are numbered P2 to P5. Ports are assigned in order, starting from P2, COM3 to COM6. For this option, the physical and internal ports match.

**If serial interface options are attached to both slots:**

Slot 1 is from COM3 to COM6, and Slot 2 is from COM7 to COM10. Disabled numbers are as described above for serial interface options: for RS-232C isolated x 2 and RS-422 x 2 the latter 2 ports are disabled, for RS-485 x 2 the first 2 ports are disabled. For RS-232C x 4, all 4 ports are enabled.

**Example 1:**

If RS-232C isolated x 2 is attached to Slot 1, and RS-422 x 2 is attached to Slot 2, COM3, COM4, COM7, and COM8 are enabled.

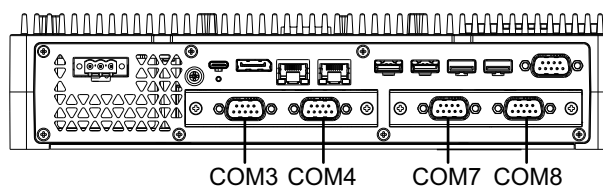
**Example 2:**

If RS-232C isolated x 2 is attached to Slot 1, and RS-485 x 2 is attached to Slot 2, COM3, COM4, COM9, and COM10 are enabled.

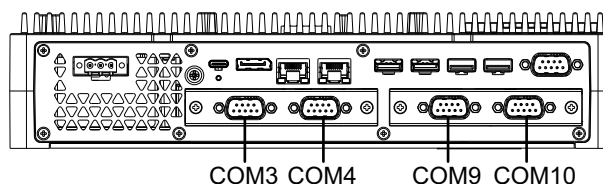
**If a serial interface option is attached to only one of the 2 slots:**

Whether connected to Slot 1 or Slot 2, disabled numbers are as described above for each serial interface option.

**Example 1:**

When the WiFi/Bluetooth option is attached to Slot 1, and RS-232C isolated x 2 is attached to Slot 2, COM3 and COM4 are enabled.

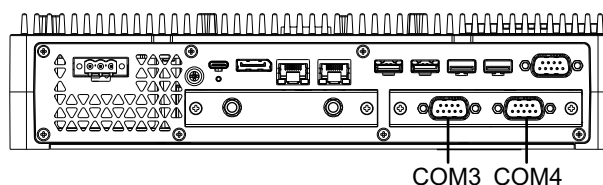



**RS-232C isolated x 2**

**Specifications**

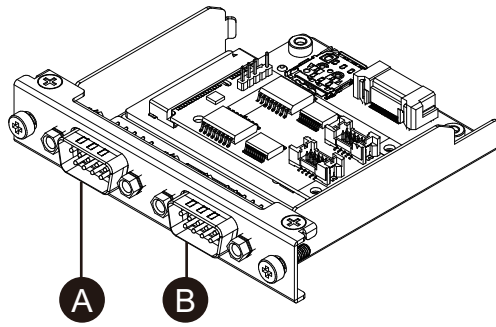

- A. After attaching to the unit, right side
- B. After attaching to the unit, left side

Product number	PFXYP6MPR23P2
Asynchronous transmission	RS-232C (isolated) x 2
Data length	7 or 8 bits
Stop bit	1 or 2 bits
Parity	None, odd or even
Data transmission speed	2,400...115,200 bps
Connector	D-Sub 9 pin (plug)
Power consumption (max.)	0.66 W

The serial interface is isolated. The SG (signal ground) and FG (frame ground) terminals are not connected inside this product. When the serial interface connector is D-Sub, connect the FG wire to the shell.

**⚡ ⚠ DANGER**

**ELECTRIC SHOCK AND FIRE**

When using the SG terminal to connect an external device to this product:

- Verify that a ground loop is not created when you set up the system.
- Connect the SG terminal to remote equipment when the external device is not isolated.
- Connect the SG terminal to a known reliable ground connection to reduce the risk of damaging the circuit.

**Failure to follow these instructions will result in death or serious injury.**

**⚠ CAUTION**

**LOSS OF COMMUNICATION**

- Do not put excessive stress on the communication ports of all connections.
- Securely attach communication cables to the panel wall or cabinet.
- Use a D-Sub 9 pin connector that has jack screws.

**Failure to follow these instructions can result in injury or equipment damage.**

**NOTE:** Use within the rated current.

## Pin Assignment

D-Sub 9 pin plug connector

Module side:

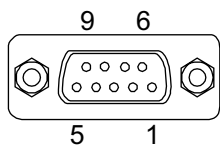

Pin No.	RS-232C		
	Signal name	Direction	Description
1	CD	Input	Carrier detect
2	RD (RXD)	Input	Receive data
3	SD (TXD)	Output	Send data
4	ER (DTR)	Output	Data terminal ready
5	SG	-	Signal ground (isolated)
6	DR (DSR)	Input	Data set ready
7	RS (RTS)	Output	Request to send
8	CS (CTS)	Input	Send possible
9	CI (RI)	Input	Called status display
Shell	FG	-	Frame ground

Recommended jack screw is #4-40 (UNC).

## RS-232C x 4

### Specifications

You can use four RS-232C ports by connecting the cable provided.

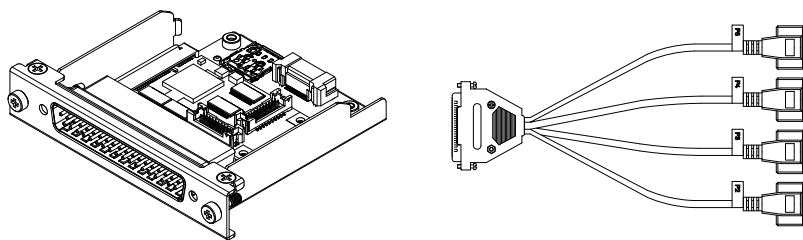

Product number	PFXYP6MPR23P4
Asynchronous transmission	RS-232C (not isolated) x 4
Data length	7 or 8 bits
Stop bit	1 or 2 bits
Parity	None, odd or even
Data transmission speed	2,400...115,200 bps
Connector	D-Sub 37 pin (plug, module side)
	D-Sub 9 pin (plug, extended cable side)
Power consumption (max.)	0.58 W

The serial interface is not isolated. The SG (signal ground) and FG (frame ground) terminals are connected inside this product. When the serial interface connector is D-Sub, connect the FG wire to the shell.

**⚠️⚠️ DANGER**

**ELECTRIC SHOCK AND FIRE**

When using the SG terminal to connect an external device to this product:

- Verify that a ground loop is not created when you set up the system.
- Connect the SG terminal to remote equipment when the external device is not isolated.
- Connect the SG terminal to a known reliable ground connection to reduce the risk of damaging the circuit.

**Failure to follow these instructions will result in death or serious injury.**

**⚠️ CAUTION**

**LOSS OF COMMUNICATION**

- Do not put excessive stress on the communication ports of all connections.
- Securely attach communication cables to the panel wall or cabinet.
- Use a D-Sub 9 pin connector that has jack screws.

**Failure to follow these instructions can result in injury or equipment damage.**

**NOTE:** Use within the rated current.

### Pin Assignment

D-Sub 9 pin plug connector

Extended cable side:

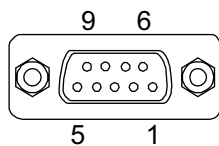

Pin No.	RS-232C		
	Signal name	Direction	Description
1	CD	Input	Carrier detect
2	RD (RXD)	Input	Receive data
3	SD (TXD)	Output	Send data
4	ER (DTR)	Output	Data terminal ready
5	SG	-	Signal ground (not isolated)
6	DR (DSR)	Input	Data set ready
7	RS (RTS)	Output	Request to send
8	CS (CTS)	Input	Send possible
9	CI (RI)	Input	Called status display
Shell	FG	-	Frame ground (common with SG)

Recommended jack screw is #4-40 (UNC).

## RS-422/485 isolated x 2

### Specifications

By factory default, the RS-485 interface is connected on the interface cartridge. Depending on your requirements, you can change the interface to a RS-422 interface included with the product.

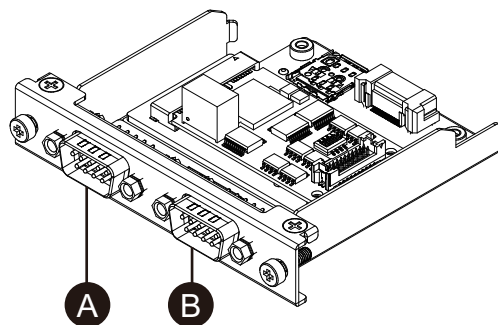

A. After attaching to the unit, right side

B. After attaching to the unit, left side

C. Red wire

RS-485 interface cable

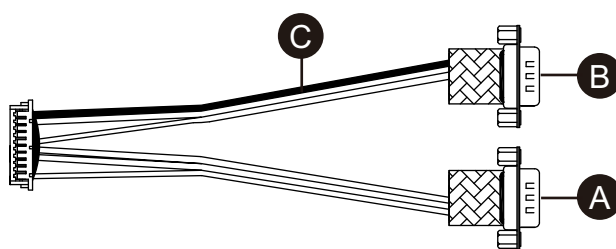

RS-422 interface cable

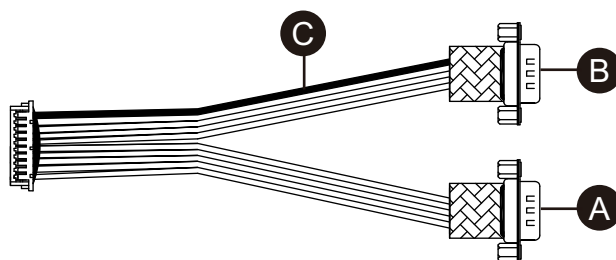

Product number	PFXYP6MPR42P2
Asynchronous transmission	RS-422 (isolated) x 2, RS-485 (isolated) x 2
Data length	7 or 8 bits
Stop bit	1 or 2 bits
Parity	None, odd or even
Flow control	xon/xoff control
Data transmission speed	2,400...115,200 bps
Connector	D-Sub 9 pin (plug)
Power consumption (max.)	0.58 W

The serial interface is isolated. The SG (signal ground) and FG (frame ground) terminals are not connected inside this product. When the serial interface connector is D-Sub, connect the FG wire to the shell.

**⚠️⚠️ DANGER**

**ELECTRIC SHOCK AND FIRE**

When using the SG terminal to connect an external device to this product:

- Verify that a ground loop is not created when you set up the system.
- Connect the SG terminal to remote equipment when the external device is not isolated.
- Connect the SG terminal to a known reliable ground connection to reduce the risk of damaging the circuit.

**Failure to follow these instructions will result in death or serious injury.**

**⚠️ CAUTION**

**LOSS OF COMMUNICATION**

- Do not put excessive stress on the communication ports of all connections.
- Securely attach communication cables to the panel wall or cabinet.
- Use a D-Sub 9 pin connector that has jack screws.

**Failure to follow these instructions can result in injury or equipment damage.**

**NOTICE**

**BROKEN ENCLOSURE**

Do not exert more torque than the amount specified.

**Failure to follow these instructions can result in equipment damage.**

**NOTE:** Use within the rated current.

**Pin Assignment**

RS-422: D-Sub 9 pin plug connector

Module side:

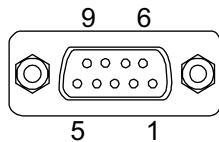

Pin No.	RS-422		
	Signal name	Direction	Description
1	TxD-	Output	Send data –
2	TxD+	Output	Send data +
3	RxD+	Input	Receive data +
4	RxD-	Input	Receive data –
5	SG	—	Signal ground (isolated)
6	NC	—	No connection

Pin No.	RS-422		
	Signal name	Direction	Description
7	NC	—	No connection
8	NC	—	No connection
9	NC	—	No connection
Shell	FG	—	Frame ground

RS-485: D-Sub 9 pin plug connector

Module side:

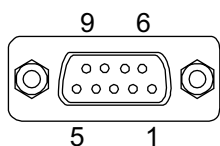

Pin No.	RS-485		
	Signal name	Direction	Description
1	Data-	Input/Output	Communication data -
2	Data+	Input/Output	Communication data +
3	NC	—	No connection
4	NC	—	No connection
5	SG	—	Signal ground (isolated)
6	NC	—	No connection
7	NC	—	No connection
8	NC	—	No connection
9	NC	—	No connection
Shell	FG	—	Frame ground

For both RS-422 and RS-485:

Recommended jack screw is #4-40 (UNC).

### Replacing with RS-422

1. Use a box wrench (5 mm) to remove the screws on the interface.

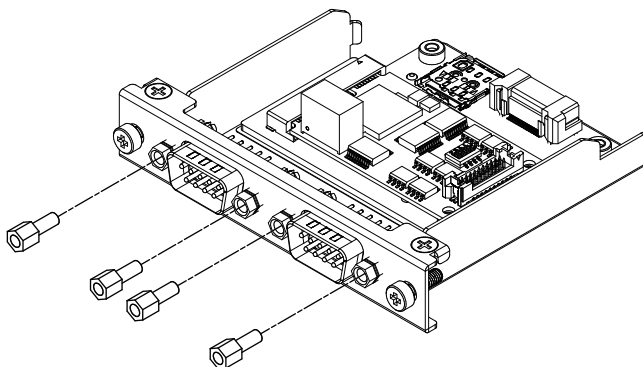

2. Disconnect the interface connector from the cartridge, and also disconnect the cable connected to the board.

- As shown below, attach the cable connector so that the cable's red wire is at position 1. Attach so that the port with the red wire is on side B.

**NOTE:** For a RS-485 connection, attach the cable connector so that the red wire is at position 2.

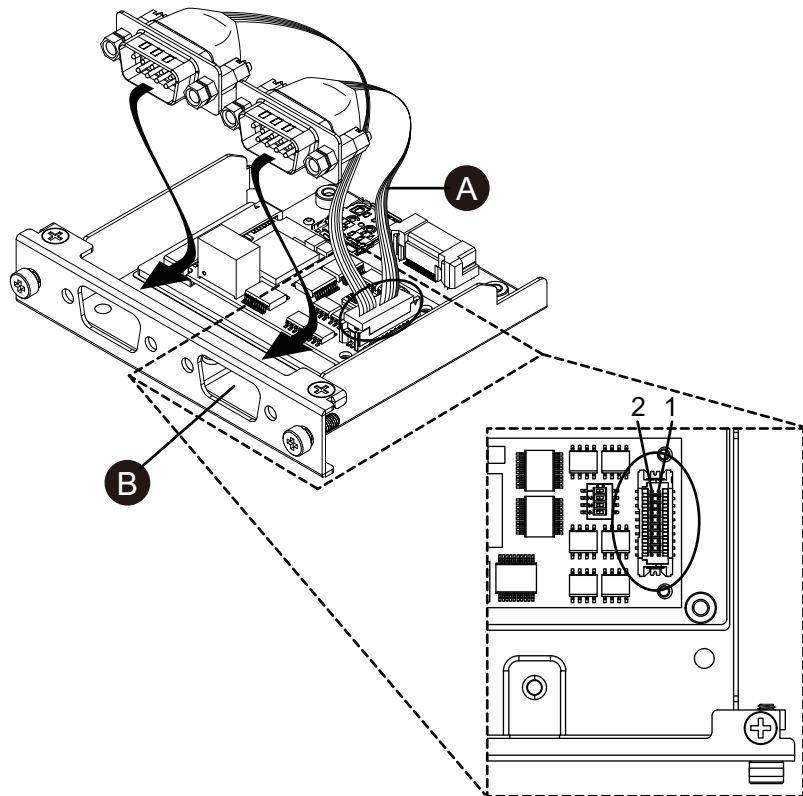

A. Red wire

- Insert the RS-422 interface connector into the cartridge and tighten the screws.

**NOTE:** The necessary torque is 0.3 N•m (2.7 lb-in).

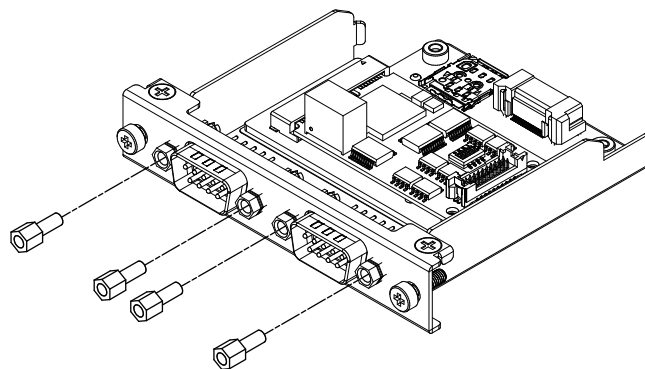

### Termination Resistor Setting

Termination resistor setting is necessary when using RS-422/485 isolated x 2. Set up by referring to the following table.

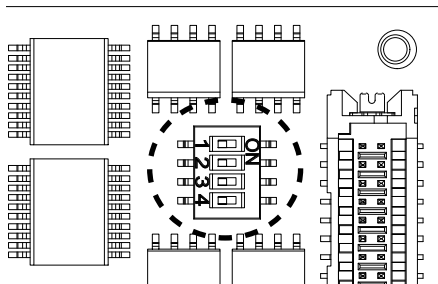

Dip SW	OFF	ON	Port
1	Normal	Termination	For RS-422 (port identified with a red wire)
2	Normal	Termination	For RS-422 (port not identified with a red wire)
3	Normal	Termination	For RS-485 (port identified with a red wire)
4	Normal	Termination	For RS-485 (port not identified with a red wire)

## Ethernet (GbE IEEE1588)

### Specifications

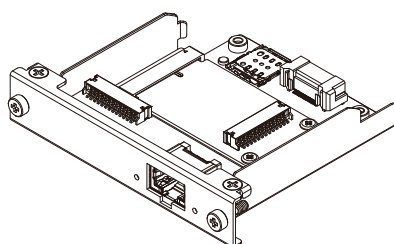

Product number	PFXYP6MPETH
Connector	Modular jack (RJ-45) x 1
Standard	IEEE1588, 10 BASE-T/100 BASE-TX/1000 BASE-T, Wake-on-LAN (WOL) supported*1
Maximum communication distance	100 m (328.1 ft)
Power consumption (max.)	0.66 W

\*1 When the status is S4 (hybrid shutdown), Wake-on-LAN is unavailable.

### **▲ CAUTION**

#### **LOSS OF COMMUNICATION**

- Do not put excessive stress on the communication ports of all connections.
- Securely attach communication cables to the panel wall or cabinet.

**Failure to follow these instructions can result in injury or equipment damage.**



### LED Indications

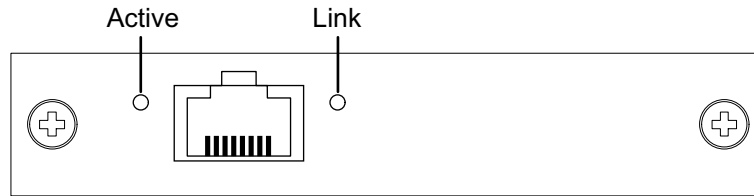

Color	Indicator	Description
Green (Active)	ON	Data transmission is available
	Flashing	Data transmission in progress
	OFF	No connection or error
Green (Link)	ON	Data transmission is available.
	OFF	No data transmission

### Audio (Mic-IN, Line-IN, Line-OUT)

#### Specifications

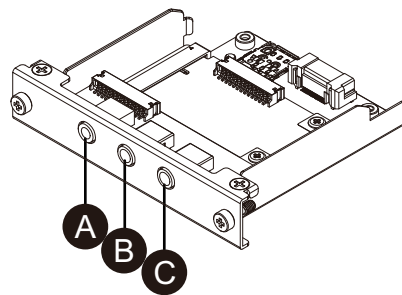

- A. Line-OUT
- B. Line-IN
- C. Mic-IN

Product number	PFXYP6MPAU
Connector	3.5 mm stereo mini jack x 3 (Mic-IN, Line-IN, Line-OUT)
Power Consumption	0.3 W
Standard	USB Audio Class Rev.1.0 and 2.0
Channels	2-channels / port
Supported Playback / Recording Sampling rate	8/16/22/24/32/44.1/48/96/176.4/192/384 kHz (16/24/32 bit)

## EtherCAT (Controller)

### NOTE:

- When this interface is attached to the product, it does not comply with DNV-GL certification.
- When this interface is attached to Advanced Box or Advanced Type, the FAN kit is required.
- When this interface is attached to the product, use in the following environment.

### Ambient air temperature:

- Advanced Box or Advanced model with FAN kit: 0...45 °C (32...113 °F)
- Standard Box or Standard model: 0...40 °C (32...104 °F)

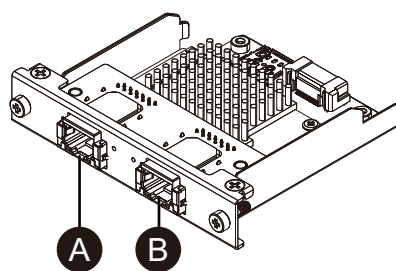

- A. EtherCAT interface  
 B. Not available (reserved)

## Specifications

Product number	PFXYP6MPECAT
Connector	Modular jack (RJ-45) x 2
Standard	IEC 61784-2 RTE CPF12, ETG.1020, ETG.1500, ETG.2100, IEEE 802.3
Power consumption (max.)	3.0 W
Link speed	100 Mbps
Maximum communication distance	100 m (328.1 ft)
Number of connectable slaves	200 (max.)
Cycle time (min.)	205 $\mu$ s  <b>NOTE:</b> Depending on the used number of slaves and the used number of cyclic input data and output data. Recommended cycle time is 1 ms or more.
Cyclic data (max.)	Input: 5,760 bytes, Output: 5,760 bytes

## **▲ CAUTION**

### LOSS OF COMMUNICATION

- Do not put excessive stress on the communication ports of all connections.
- Securely attach communication cables to the panel wall or cabinet.

**Failure to follow these instructions can result in injury or equipment damage.**

### LED Indications

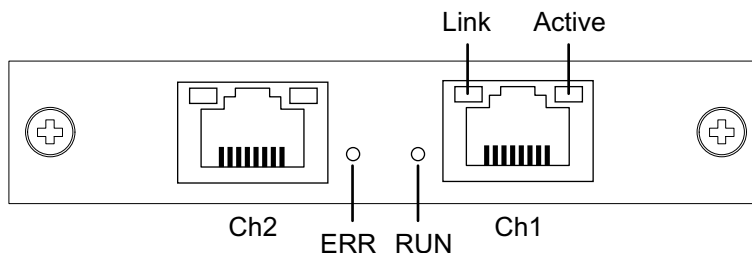

LED	Color	Indicator	Description
RUN	Green	ON	Operational
		Single Flash*1	Safe-operational
		Flickering*2	Boot
		Blinking*3	Pre-operational
		OFF	INIT
ERR	Red	ON	Communication error
		OFF	No errors
Link	Green	ON	Link to Ethernet
		OFF	Not linked to Ethernet
Active	Yellow	Flickering	Sending/Receiving Ethernet frames
		OFF	Not sending/receiving Ethernet frames

\*1 Single flash: Repeats 200 ms ON and 1 second OFF

\*2 Flickering: Flashes every 50 ms

\*3 Blinking: Flashes every 200 ms

### EtherCAT Driver and Firmware Installation

1. Download the EtherCAT Utility/Driver file (PFXPHMIP6\_EtherCAT\_\*\*\*\*\*.zip) from our site. <https://www.pro-face.com/trans/en/manual/1085.html>

2. Install the driver. Unzip the downloaded file, select **Driver\_& Toolkit > Device Driver (NXDRV-WIN) > Installation**, and run **ciFX Device Driver Setup**. Install following the on-screen instructions.

**NOTE:** The file storage location may change depending on the version.

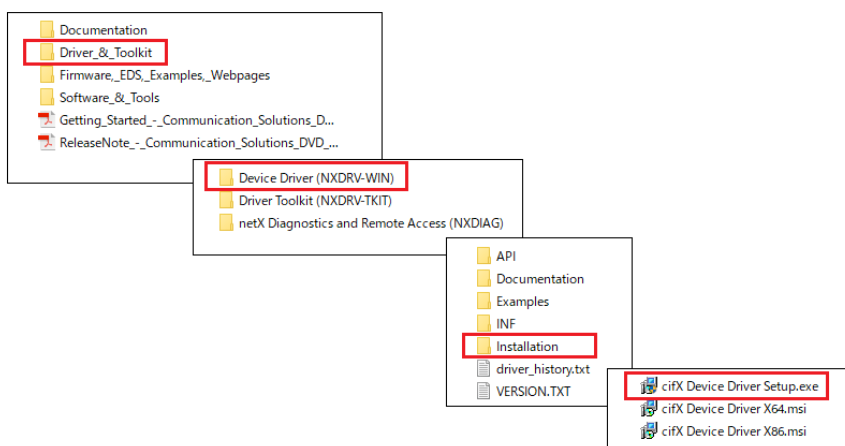

3. Next, install SYCON.net. Select **Software\_& Tools > Configuration Software > SYCON.net > SYCON.net**, and run **SYCONnet netX Setup**. Install following the on-screen instructions.

**NOTE:** The file storage location may change depending on the version.

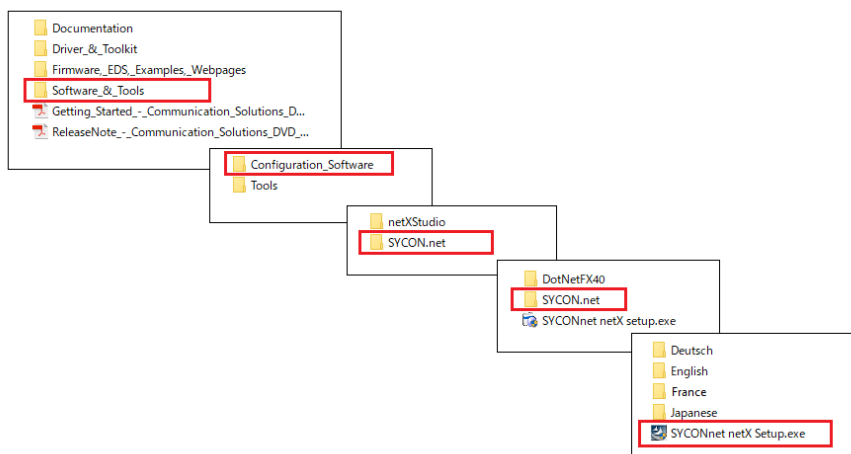

4. From the Windows Start menu, select **SYCON.net**.

- The login screen is displayed. Click **OK**.

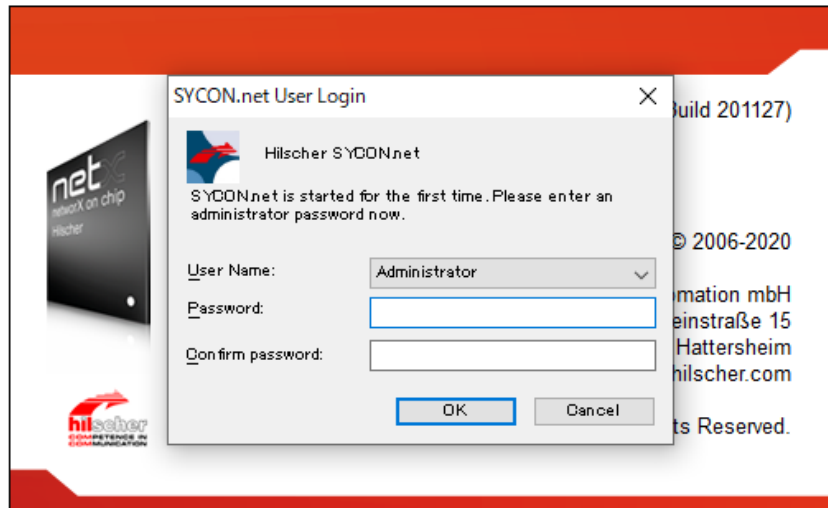

- In the right-pane of the displayed screen, open **EtherCAT > Master**, and drag **CIFX RE/ECM** to the **netDevice** line.

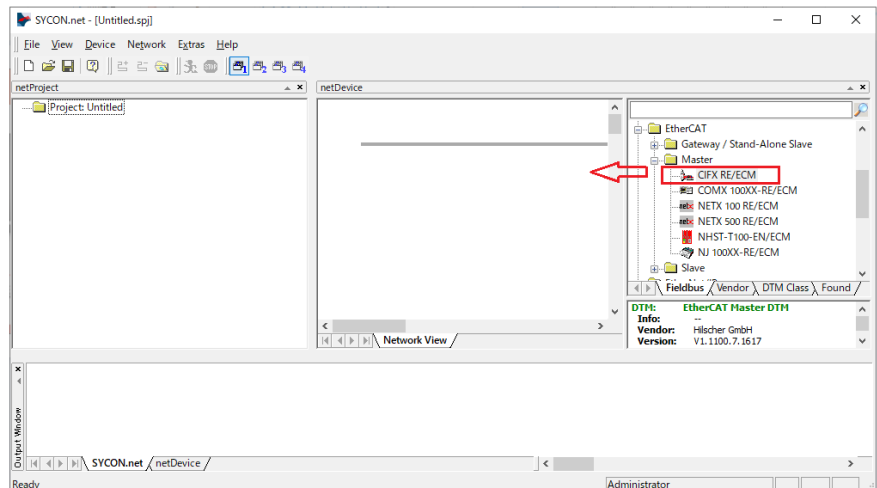

- Double-click the displayed icon.

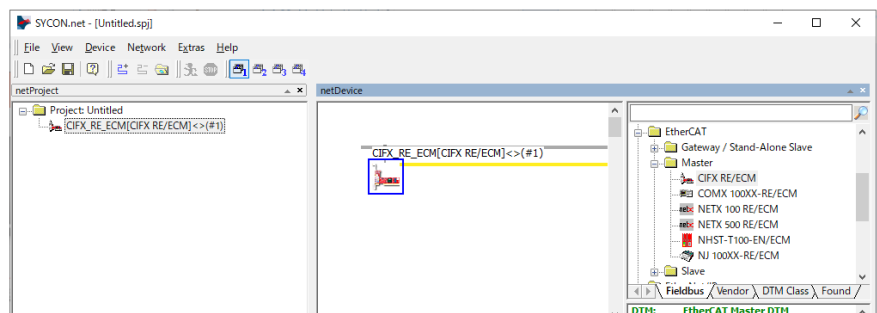

8. The following screen appears. Select **Settings > Driver**. Select the **CIFX Device Driver** and **netX Driver** check boxes, and select **Apply**.

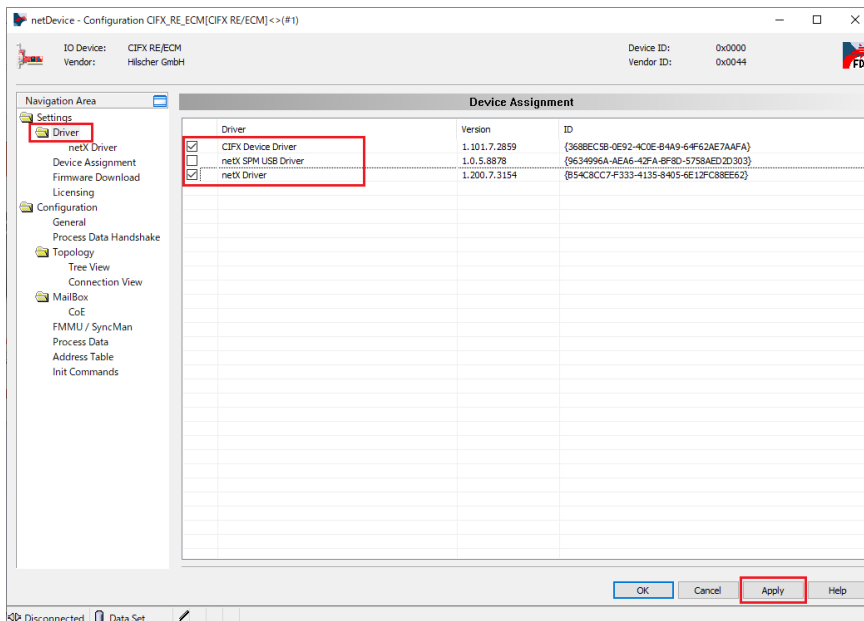

9. Select **Settings > Device Assignment**. Confirm **Device Selection** is set to **all**, and click **Scan**. In the following, select the applicable items, and click **Apply**.

Device: CIFX 90E-RE\ET  
Channel Protocol: EtherCAT Master

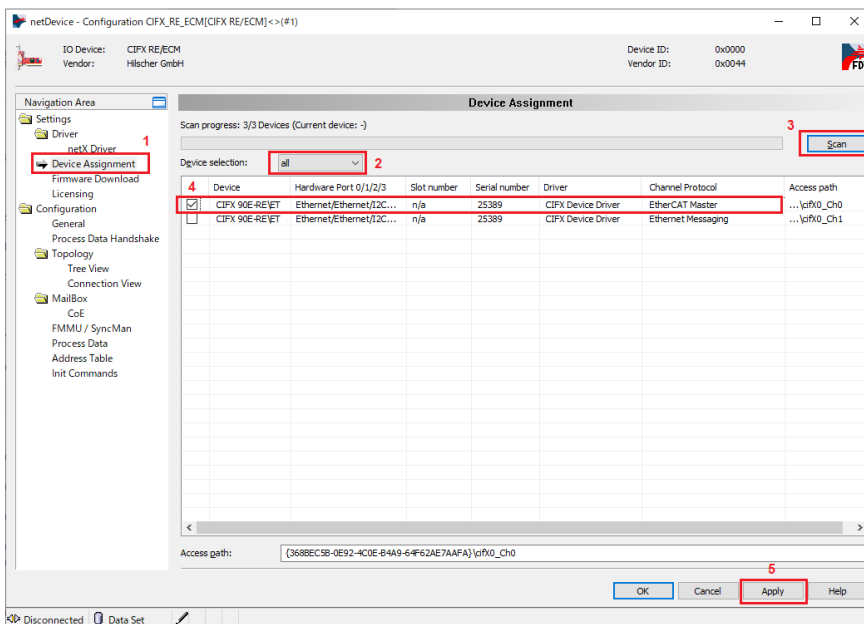

10. Select **Firmware Download** and click **Browse**.

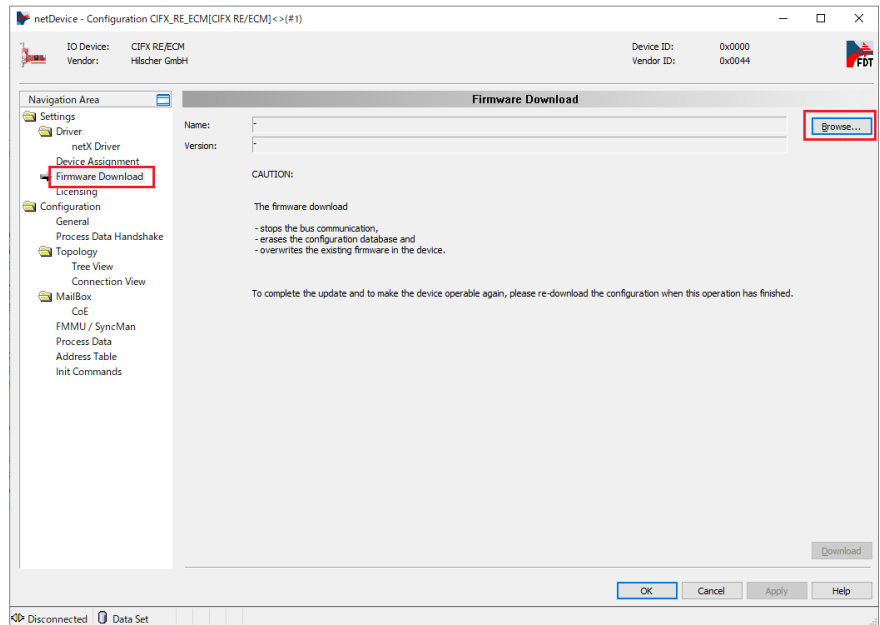

11. From the **Firmware > CIFX** folders, select the firmware file **cifxecm.nxf**. Click **Open**.

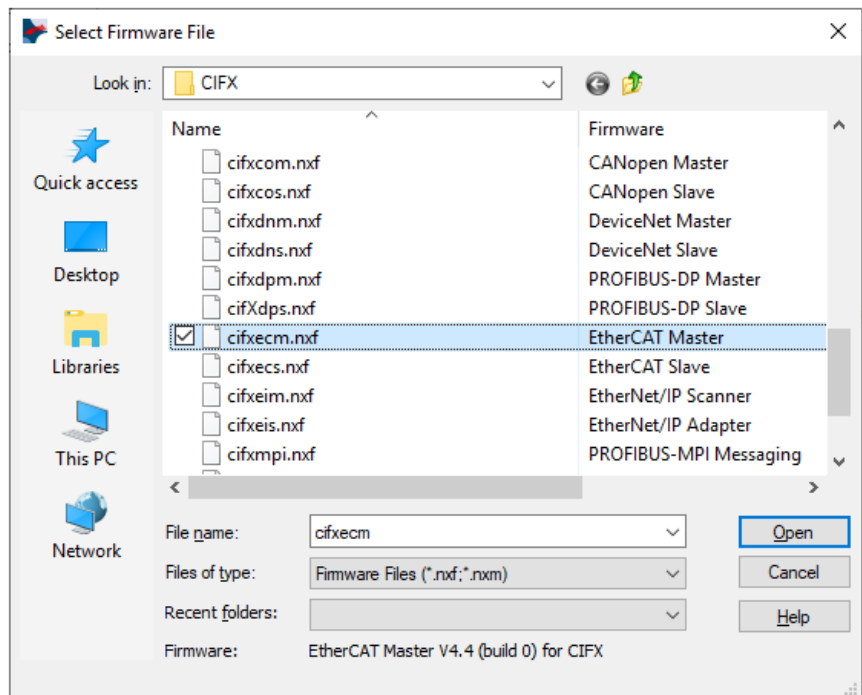

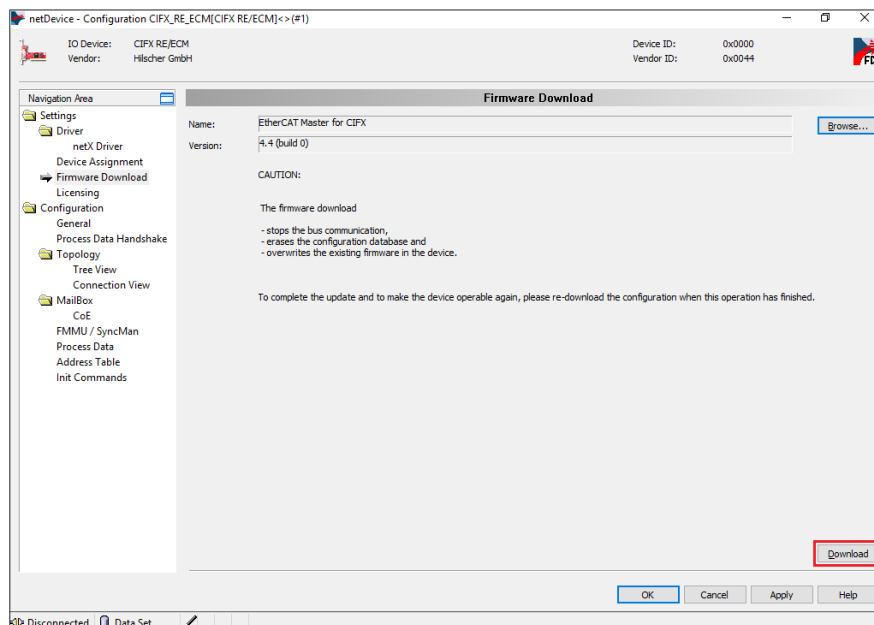
12. Click **Download**.

## WiFi/Bluetooth with antennas

By attaching antennas, this interface can receive WiFi signals.

**NOTE:**

- This product/accessory has not obtained standards or certifications related to radio frequency. Please obtain if required by the standards and certifications in your country. You can find the certification information on the Wifi/Bluetooth card on our website. Search with the Wifi/Bluetooth model number (PFXY6MPWF).  
<https://www.pro-face.com/trans/en/manual/1002.html>
- Use this product in accordance with the laws, regulations and standards of your country.

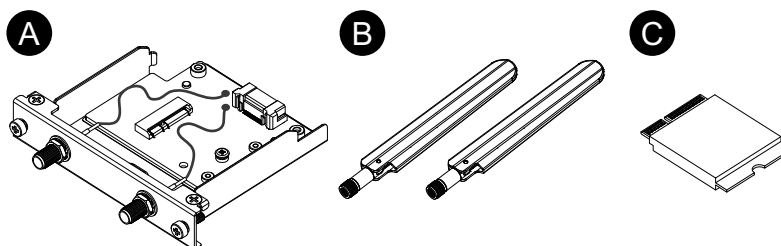
**Package Contents**

- A. WiFi/Bluetooth interface
- B. Antenna
- C. WiFi/Bluetooth card



**Antenna Size**

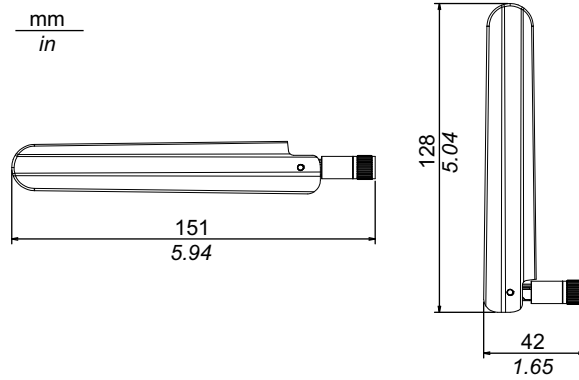

**Specifications**

Product number		PFXY6MPWF
WiFi	Connector	Antenna connector (SMA plug) x 2
	Transmission speed	IEEE802.11a: max 54 Mbps IEEE802.11b: max 11 Mbps IEEE802.11g: max 54 Mbps IEEE802.11n: max 600 Mbps IEEE802.11ac: max 1733 Mbps
	Network authentication	WPA, WPA2, 801.1X
	Data encryption	WEP (64 bit and 128 bit), TKIP, AES-CCMP (128 bit), AES-GCMP (128 bit and 256 bit)
Bluetooth	Standard	Bluetooth 5.1
	Power class	Class 1
Power consumption (max.)	5.1 W	

**▲ WARNING**

**ELECTROMAGNETIC / RADIO INTERFERENCE**

If you are uncertain of the policy that applies to the use of the WiFi/Bluetooth module, ask the administrator about its use before you turn it on.

**Failure to follow these instructions can result in death, serious injury, or equipment damage.**

**2.4 GHz Wireless Devices**

The WiFi/Bluetooth module uses the 2.4 GHz frequency range, which is used by a wide range of wireless equipment. Example usage includes industrial, scientific, and medical equipment such as microwave ovens, on-site wireless stations (requiring licenses), low-power wireless stations (not requiring licenses) as well as amateur wireless stations (requiring licenses).

1. Before use, confirm that no on-site wireless stations and specified low-power wireless stations or amateur wireless stations operate in your vicinity.
2. In the event that the WiFi/Bluetooth module causes harmful interference to any other "on-site wireless stations", immediately change the channel frequency of the WiFi/Bluetooth module, or change its location, or halt operation of radio emissions and contact the administrator of the wireless network to resolve the issue.

**Security on Your Wireless LAN**

Because wireless LANs do not normally provide adequate data security, the following problems may occur.

1. Unlawful access of communication information.

- There is a chance that information found in emails, and personal information such as user IDs, passwords, and credit card numbers, may be intentionally intercepted by a malicious third party.

## 2. Illegal Access

A malicious third party may be able to access personal or company data over the company's local area network without permission, to:

- Obtain personal and confidential information (information leak)
- Impersonate someone by communicating as that person and disseminating invalid information (spoofing)
- Alter intercepted communications and re-transmitting tolerated content (falsification)
- Cause critical damage to data and or systems due to a computer virus (damage).

This wireless LAN product includes security features that enable you to configure security-related settings that reduce the likelihood of the above-mentioned problems.

We recommend that you make yourself fully acquainted with the possible implications of what might happen if you use a wireless product without enabling security features, and that you configure security-related settings and use wireless products at your own responsibility.

## Attaching the WiFi/Bluetooth Card and Antennas

### ▲ CAUTION

#### LOSS OF COMMUNICATION

Do not put excessive stress on the communication ports of all connections.

**Failure to follow these instructions can result in injury or equipment damage.**

1. Remove the screw from the installation area of the WiFi/Bluetooth card on the interface unit.

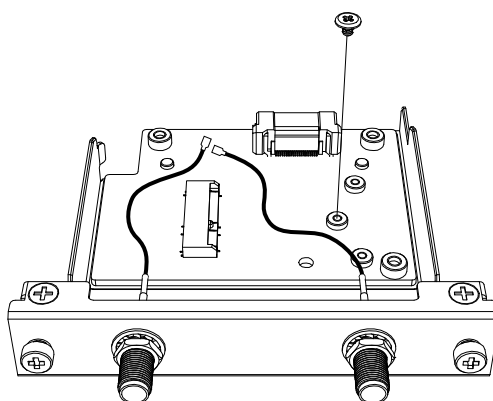

2. As shown below, insert the WiFi/Bluetooth card diagonally, then push from above.

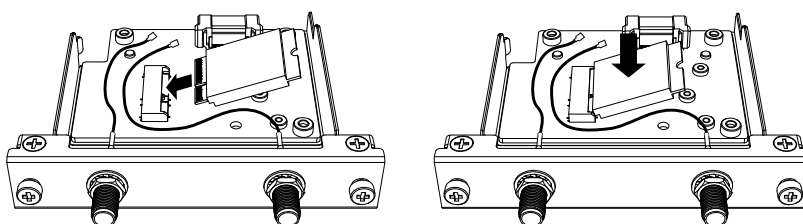

- Secure the card with the screw removed in step 1.

**NOTE:**

- Using a Phillips screwdriver #1 is recommended.
- The necessary torque is 0.2 N•m (1.77 lb-in).

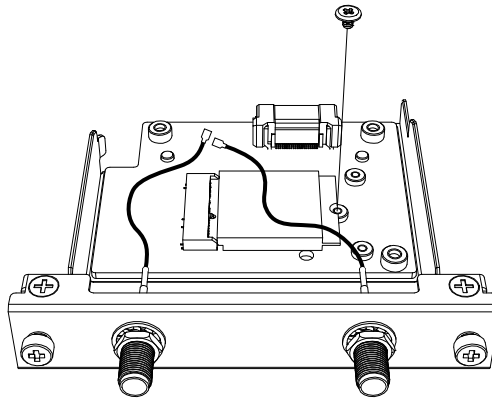

- As shown below, plug the antenna cable connector securely to the connector on the card. Looking from above the interface, plug the cable connector on the left side to connector 1, and the cable connector on the right side to connector 2.

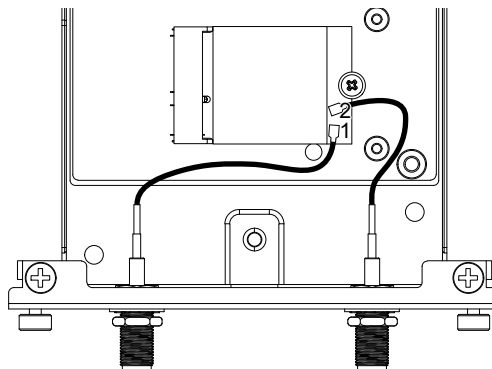

5. Attach this interface to the product. Attach the antenna only after mounting the product on the panel.

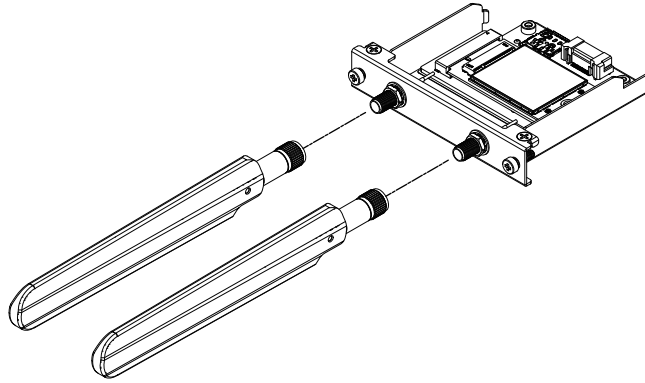

Do not block the antenna area with your hand, body or other objects. It may cause interference in communications.

You can change the direction of antennas, up, down, left and right.

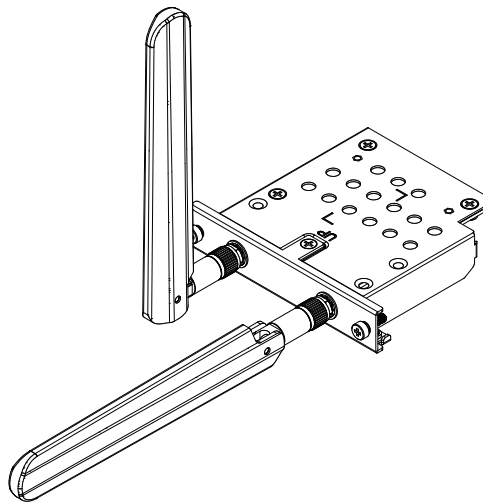

You can attach the antenna to the outside of the panel using the following optional cable.

WiFi/Bluetooth expanded antenna cable (3 m): PFXYP6CBWF3M

When the optional cable is used, the dimensions of the panel opening is as follows.

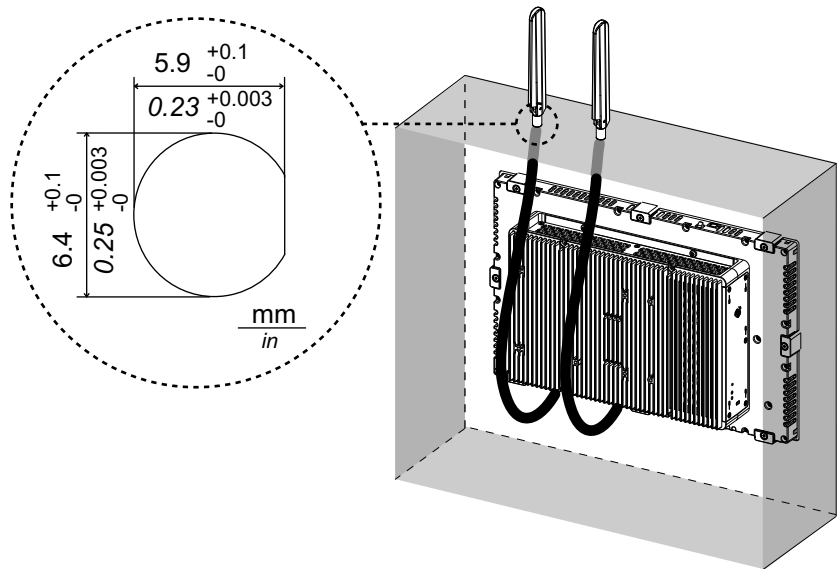

## 4G Cellular

By attaching this interface unit and a SIM card, this product can connect a 4G network.

**NOTE:**

- Use the interface unit and SIM card that match the frequency in your country.
- Use this product in accordance with the laws, regulations and standards of your country.
- This product/accessory has not obtained standards or certifications related to radio frequency. Please obtain if required by the standards and certifications in your country.

### Package Contents

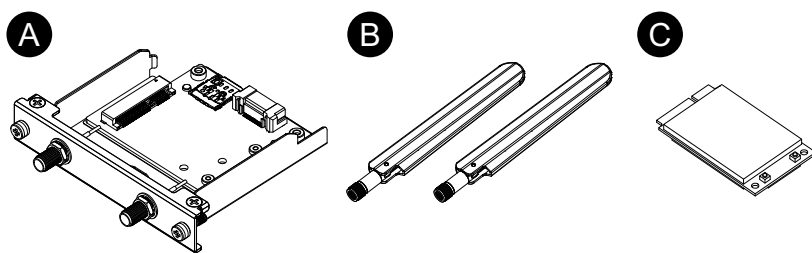

- A. 4G cellular interface
- B. Antenna
- C. 4G mini PCIe card

## Antenna Size

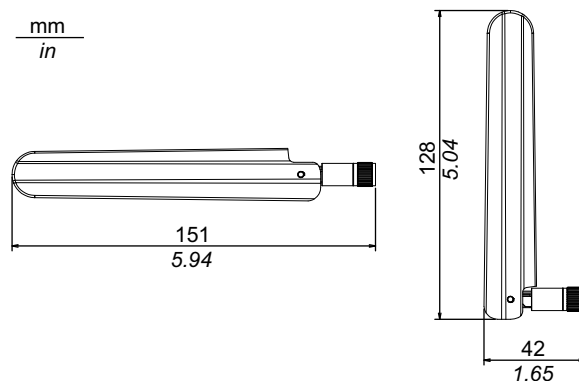

## Specifications

	EU, Asia and Japan model	US model
Product number	PFXYP6MP4GE	PFXYP6MP4GU
SIM card type	micro SIM 3FF, 12 x 15 mm	

## 4G

	EU, Asia and Japan model	US model
Power consumption	2.9 W	
Standard	4G LTE: 3GPP Release 9, E-UTRA, FDD, MIMO	
Band	MPCI-L210 <sup>4</sup> : Band 20 (800 MHz), Band 5 (850 MHz), Band 8 (900 MHz), Band 3 (1,800 MHz), Band 1 (2,100 MHz), Band 7 (2,600 MHz)	MPCI-L200: Band 17 (700 MHz), Band 5 (850 MHz), Band 4 (1,700 MHz), Band 2 (1,900 MHz), Band 7 (2,600 MHz)
Link speed <sup>*1</sup>	Up to 150 Mb/s DL, 50 Mb/s UL	

\*1 These values depend on your service provider, the distance between this product and the base station, and the current traffic.

## 3G

	EU, Asia and Japan model	US model
Power consumption	2.6 W	
Standard	3G UMTS/HSDPA/HSUPA: 3GPP Release 8, DC-HSPA+, UTRA, FDD	

	EU, Asia and Japan model	US model
Band	MPCI-L210: Band 5 (850 MHz), Band 8 (900 MHz), Band 2 (1,900 MHz), Band 1 (2,100 MHz)	MPCI-L200: Band 5 (850 MHz), Band 8 (900 MHz), Band 4 (AWS, i.e. 1,700 MHz), Band 2 (1,900 MHz), Band 1 (2,100 MHz)
Link speed*1	HSDPA cat.24, up to 42 Mb/s DL, HSUPA cat.6, up to 5.6 Mb/s UL	HSDPA cat.14, up to 21 Mb/s DL, HSUPA cat.6, up to 5.6 Mb/s UL

\*1 These values depend on your service provider, the distance between this product and the base station, and the current traffic.

**NOTE:** 2G communication (GSM) is not available.

### Attaching the 4G mini PCIe card and SIM card

**⚠ CAUTION**

**LOSS OF COMMUNICATION**

Do not put excessive stress on the communication ports of all connections.

**Failure to follow these instructions can result in injury or equipment damage.**

1. Remove two screws from the installation area of the 4G mini PCIe card on the 4G cellular interface.

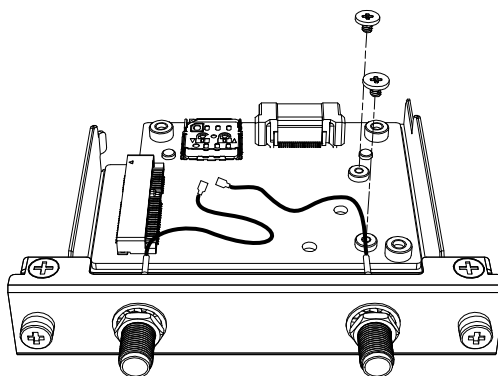

2. Connect the 4G mini PCIe card to slot.

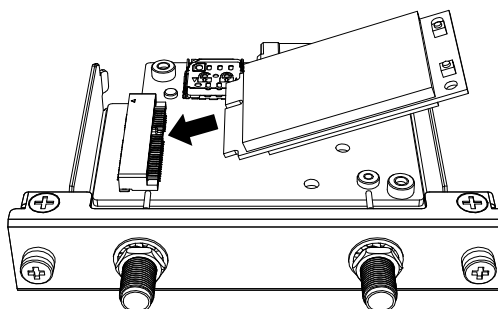

3. Push the 4G mini PCIe card from above and secure it with the screws removed in step 1.

**NOTE:**

- Using a Phillips screwdriver #1 is recommended.
- The necessary torque is 0.2 N•m (1.77 lb-in).

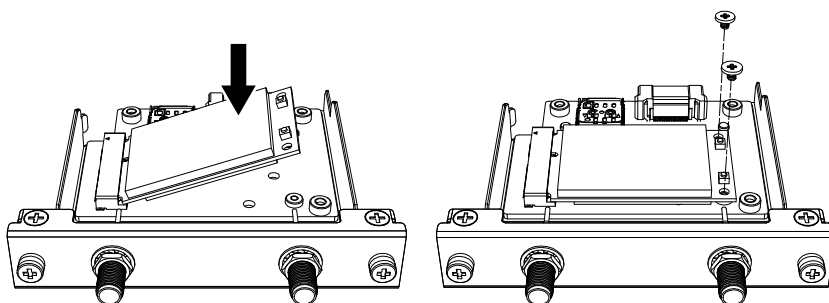

4. As shown below, plug the antenna cable connector securely to the connector on the 4G mini PCIe card. Looking from above the interface, plug the cable connector on the left side to connector 1, and the cable connector on the right side to connector 2.

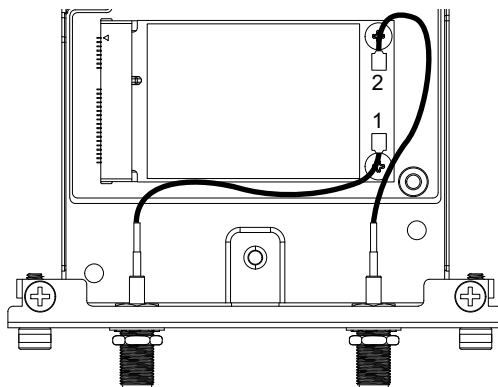

5. Slide the cover of the SIM card holder in the direction of the arrow to open it.

**NOTE:** Do not use the SIM card holder on the back of the 4G mini PCIe card.

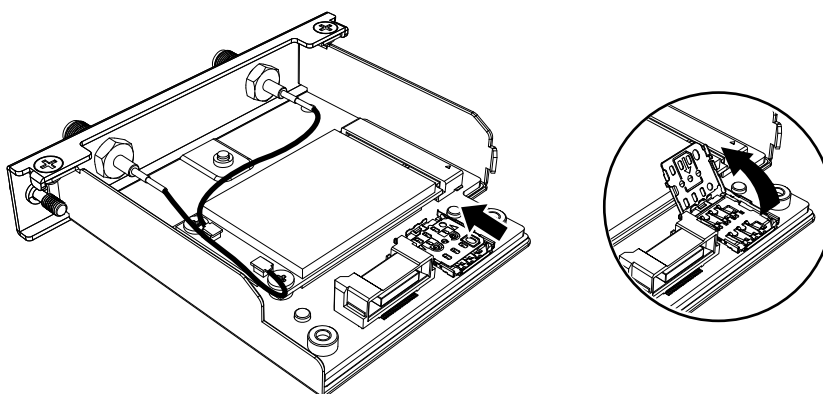



6. Insert the SIM card into the slot.

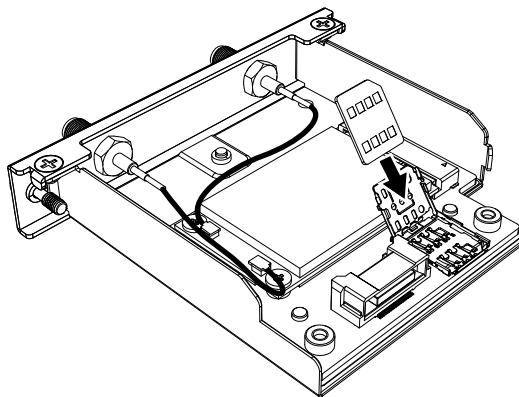

7. Close and slide the cover in the direction of the arrow to lock.

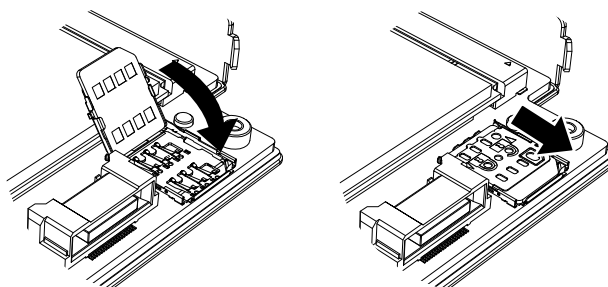

**NOTE:** When removing, inserting, or replacing the SIM card, 4G Cellular must be reset to its factory default. From 4G Cellular Settings, page 131, perform step 1.

8. Attach this interface to the product. Attach the antenna only after mounting the product on the panel.

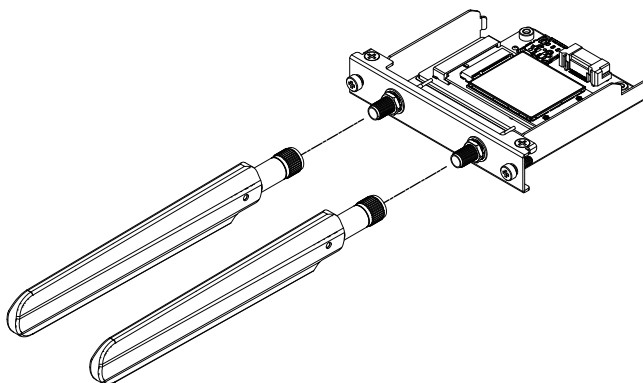

Do not block the antenna area with your hand, body or other objects. It may cause interference in communications.

You can change the direction of antennas, up, down, left and right.

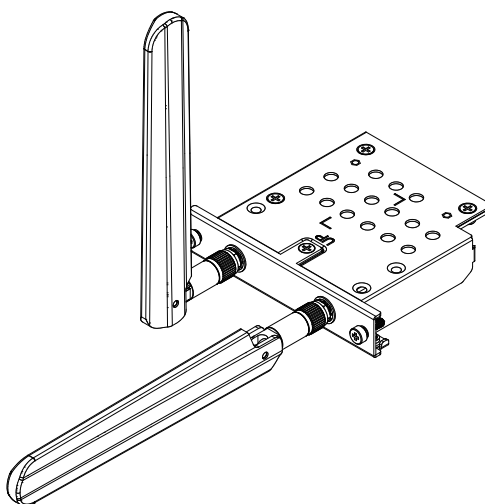

You can attach the antenna to the outside of the panel using the following optional cable.

4G Cellular extended antenna cable (3 m): PFXYP6CB4G3M

When the optional cable is used, the dimensions of the panel opening is as follows.

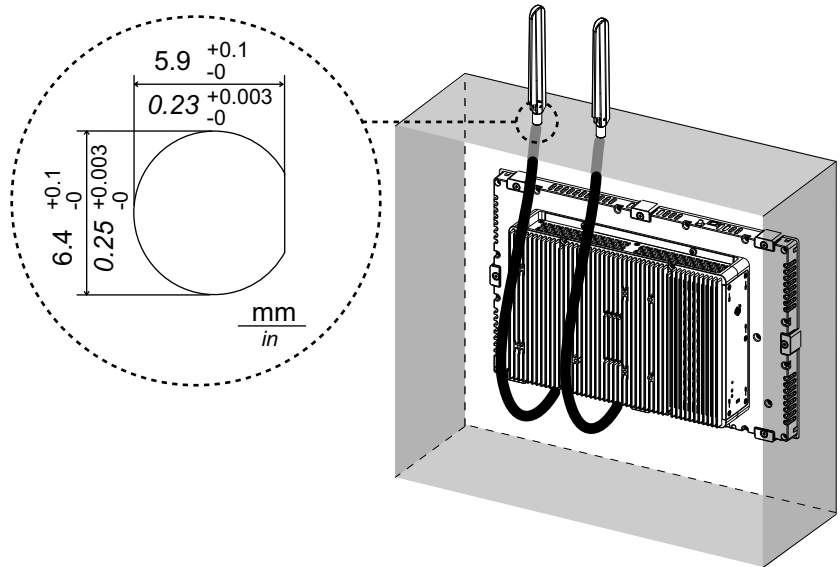

## 4G Cellular Settings

**NOTE:** When you use the following system version of the product, or when the **Cellular** icon is unavailable in the Launcher, download the utility (PFXPHMIP6\_Utility\_Installer\_Ver.x.x.zip) from our website and install by following the instructions.

<https://www.pro-face.com/trans/en/manual/1085.html>

**System Version:**

**OS Base:** 2.0 or lower

**OS Patch:** None

You can check the system version from the Launcher. Refer to System, page 165.

1. To restore the factory default setting, in the location below, click the file 4gCellular\_FactoryReset.  
Location: C:\Program Files (x86)\Schneider Electric\Utilities\4gCellularControl\4gCellular\_FactoryReset  
After setup is complete, a message will display. After shutting down the system, restart the product.
2. Start the Launcher and touch the Cellular icon.
3. Touch the down arrow.

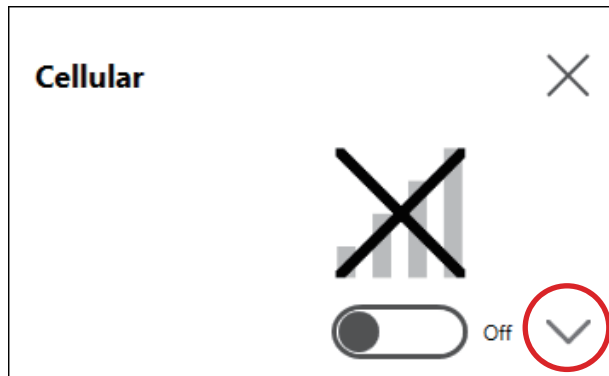

4. Configure the **APN Settings**. As specified by the SIM card provider, enter the APN address, authentication type, user name and password. Select a **Network type**.

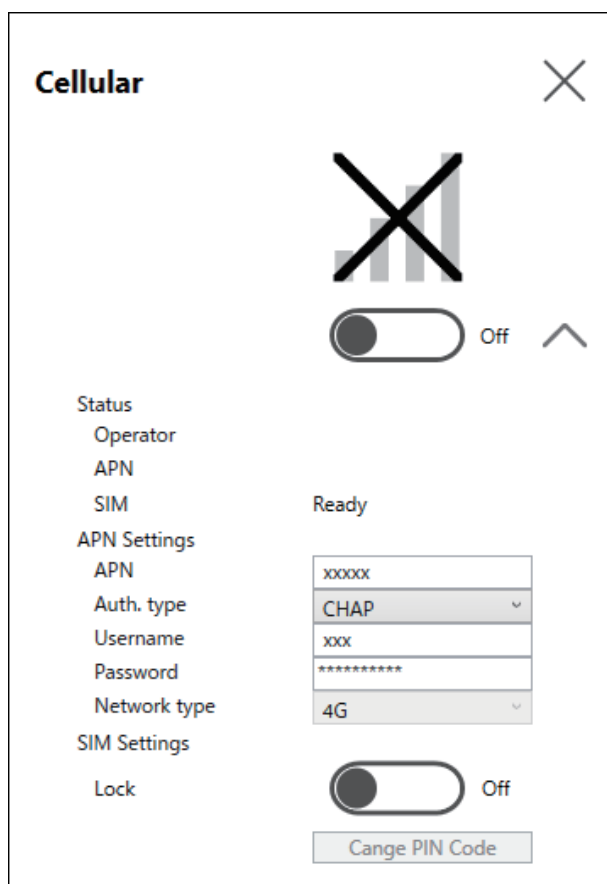

5. To lock the SIM, set **Lock On**. In the following screen, enter a 4 to 8 digit number.

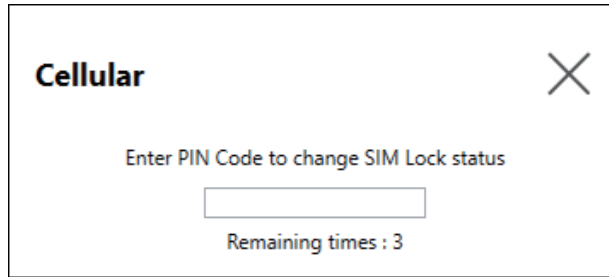

The screenshot shows a dialog box titled "Cellular" with a close button (X) in the top right corner. The main text reads "Enter PIN Code to change SIM Lock status". Below this text is a single text input field. At the bottom of the dialog, it says "Remaining times : 3".

**NOTE:**

- To prevent the SIM card from being stolen, we recommend locking the SIM.
- The PIN Code is also required to release the SIM lock. Make a note so you do not forget the code.
- If you enter the wrong PIN Code 3 times, contact the SIM card provider for a PUK code. If you enter the wrong PUK Code and use up all the allowed attempts, the SIM card can no longer be used.

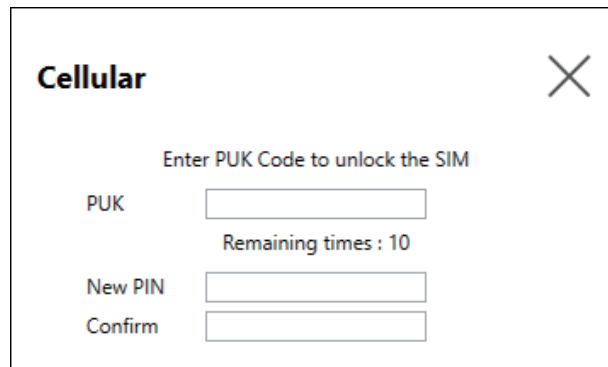

The screenshot shows a dialog box titled "Cellular" with a close button (X) in the top right corner. The main text reads "Enter PUK Code to unlock the SIM". Below this text are three text input fields labeled "PUK", "New PIN", and "Confirm". Below the "PUK" field, it says "Remaining times : 10".

6. Turn **Cellular On** and close the screen.

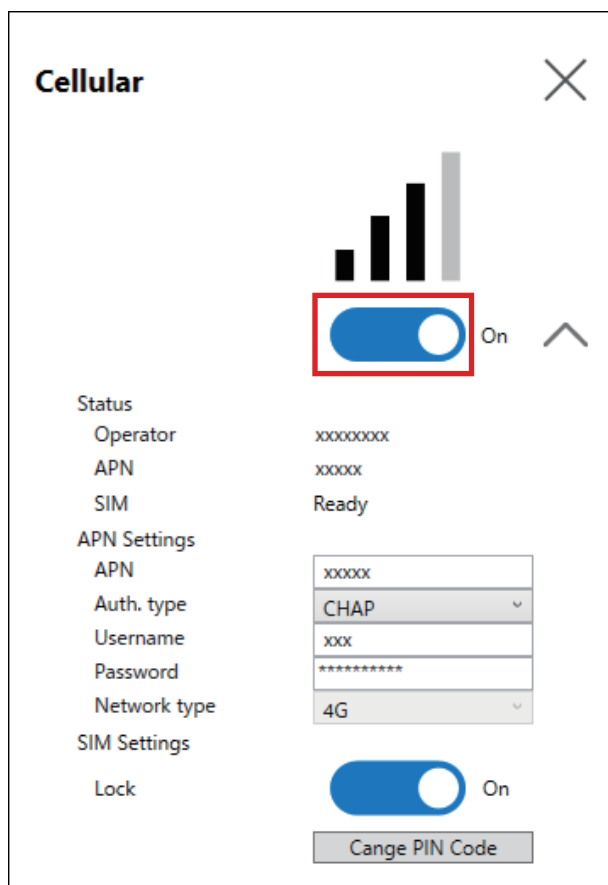

## 16DI/8DO

By using this digital I/O interface, you can control external I/O. Attach the interface unit to this product, and also use the cable included to connect to 16DI/8DO DIN rail terminal unit. The terminal unit is designed for mounting on the DIN rail.

### NOTE:

- When this 16DI/8DO interface is installed on the product, it does not comply with the UL certification.
- The API and sample utility (including source code) are published on our website. For the file to download, refer to API, page 181.

## Package Contents

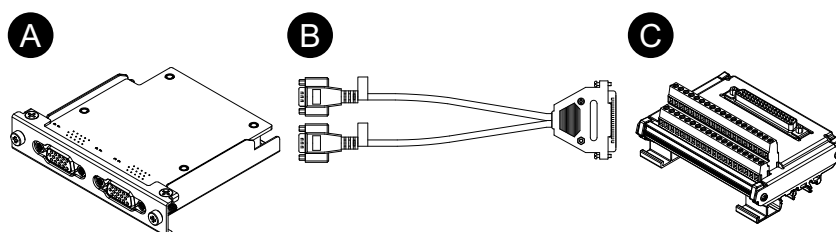

- 16DI/8DO interface
- Connection cable (2 m)
- Terminal unit

### Specifications

Product number		PFXYP6MPX16Y8
Connector		D-Sub 15 pin (socket) x 2
Power consumption (max.)		1.4 W
Digital input	Channels	16
	Input voltage	Wet contact Logic 0: 0...3 Vdc, Logic 1: 10...30 Vdc Dry contact Logic 0: Open, Logic 1: GND
	Input current	0.5 mA (10 Vdc) ... 9 mA (30 Vdc)
	Over voltage protection	70 Vdc
	Isolation voltage	1,250 Vac
	Response time	Type.50 µs, (max.: 65 µs)
	Internal power supply for dry contact	12 Vdc (max.: 2.3 mA/ch)
Digital output	Channels	8
	Output type	MOS FET
	Output voltage	5...30 Vdc
	Sink current (max.)	100 mA/ch
	Isolation voltage	1,250 Vac
	Response time	Type.50 µs, (max.: 65 µs)
Counter	Channels	2
	Resolution	32 bit
	Input frequency (max.)	When the de-bounce function is disabled: 10 kHz When the de-bounce function is enabled: 25 Hz

### Pin Assignment

Module side: D-Sub 15 pin socket connector x 2

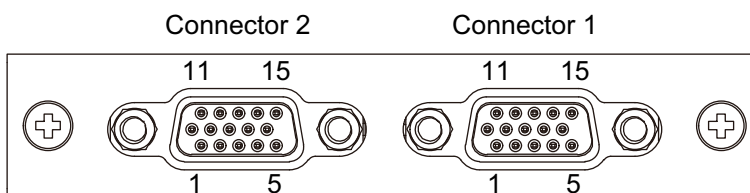

#### Connector 1

Pin No.	Signal name	Direction	Description
1	DI0/CNT0	Input	Digital input ch0/Counter input ch0
2	DI1	Input	Digital input ch1
3	DI2	Input	Digital input ch2
4	DI3	Input	Digital input ch3
5	DI4/CNT1	Input	Digital input ch4/Counter input ch1
6	DI5	Input	Digital input ch5
7	DI6	Input	Digital input ch6

Pin No.	Signal name	Direction	Description
8	DI7	Input	Digital input ch7
9	ECOM	-	External common of DI
10	EGND	-	External ground
11	DO0	Output	Digital output ch0
12	DO1	Output	Digital output ch1
13	DO2	Output	Digital output ch2
14	DO3	Output	Digital output ch3
15	PCOM	-	Freewheeling common diode for DO
Shell	FG	-	Frame ground

### Connector 2

Pin No.	Signal name	Direction	Description
1	DI8	Input	Digital input ch8
2	DI9	Input	Digital input ch9
3	DI10	Input	Digital input ch10
4	DI11	Input	Digital input ch11
5	DI12	Input	Digital input ch12
6	DI13	Input	Digital input ch13
7	DI14	Input	Digital input ch14
8	DI15	Input	Digital input ch15
9	ECOM	-	External common of DI
10	EGND	-	External ground
11	DO4	Output	Digital output ch4
12	DO5	Output	Digital output ch5
13	DO6	Output	Digital output ch6
14	DO7	Output	Digital output ch7
15	PCOM	-	Freewheeling common diode for DO
Shell	FG	-	Frame ground

Recommended jack screw is #4-40 (UNC).

### Pin Assignment of Terminal Unit

Terminal unit side: D-Sub 37 pin socket connector

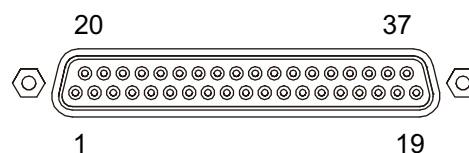

Pin No.	Signal name	Direction	Description
1	DI0/CNT0	Input	Digital input ch0/Counter input ch0
2	DI2	Input	Digital input ch2
3	DI4/CNT1	Input	Digital input ch4/Counter input ch1



Pin No.	Signal name	Direction	Description
4	DI6	Input	Digital input ch6
5	DI8	Input	Digital input ch8
6	DI10	Input	Digital input ch10
7	DI12	Input	Digital input ch12
8	DI14	Input	Digital input ch14
9	ECOM0	-	External common of DI
10	PCOM	-	Freewheeling common diode for DO
11	DO0	Output	Digital output ch0
12	DO2	Output	Digital output ch2
13	DO4	Output	Digital output ch4
14	DO6	Output	Digital output ch6
15...19	NC	-	No connection
20	DI1	Input	Digital input ch1
21	DI3	Input	Digital input ch3
22	DI5	Input	Digital input ch5
23	DI7	Input	Digital input ch7
24	DI9	Input	Digital input ch9
25	DI11	Input	Digital input ch11
26	DI13	Input	Digital input ch13
27	DI15	Input	Digital input ch15
28	ECOM1	-	External common of DI
29	EGND	-	External ground
30	DO1	Output	Digital output ch1
31	DO3	Output	Digital output ch3
32	DO5	Output	Digital output ch5
33	DO7	Output	Digital output ch7
34...37	NC	-	No connection
Shell	FG	-	Frame ground

Recommended jack screw is #4-40 (UNC).

**Screw terminal: 38 pin**

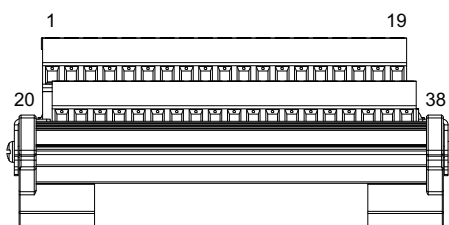

Pin No.	Signal name	Direction	Description
1	DI0/CNT0	Input	Digital input ch0/Counter input ch0
2	DI2	Input	Digital input ch2
3	DI4/CNT1	Input	Digital input ch4/Counter input ch1

Pin No.	Signal name	Direction	Description
4	DI6	Input	Digital input ch6
5	DI8	Input	Digital input ch8
6	DI10	Input	Digital input ch10
7	DI12	Input	Digital input ch12
8	DI14	Input	Digital input ch14
9	ECOM0	-	External common of DI
10	PCOM	-	Freewheeling common diode for DO
11	DO0	Output	Digital output ch0
12	DO2	Output	Digital output ch2
13	DO4	Output	Digital output ch4
14	DO6	Output	Digital output ch6
15...19	NC	-	No connection
20	DI1	Input	Digital input ch1
21	DI3	Input	Digital input ch3
22	DI5	Input	Digital input ch5
23	DI7	Input	Digital input ch7
24	DI9	Input	Digital input ch9
25	DI11	Input	Digital input ch11
26	DI13	Input	Digital input ch13
27	DI15	Input	Digital input ch15
28	ECOM1	-	External common of DI
29	EGND	-	External ground
30	DO1	Output	Digital output ch1
31	DO3	Output	Digital output ch3
32	DO5	Output	Digital output ch5
33	DO7	Output	Digital output ch7
34...37	NC	-	No connection
38	FG	-	Frame ground

### Example Connection with External Device

#### Digital input circuit (wet contact)

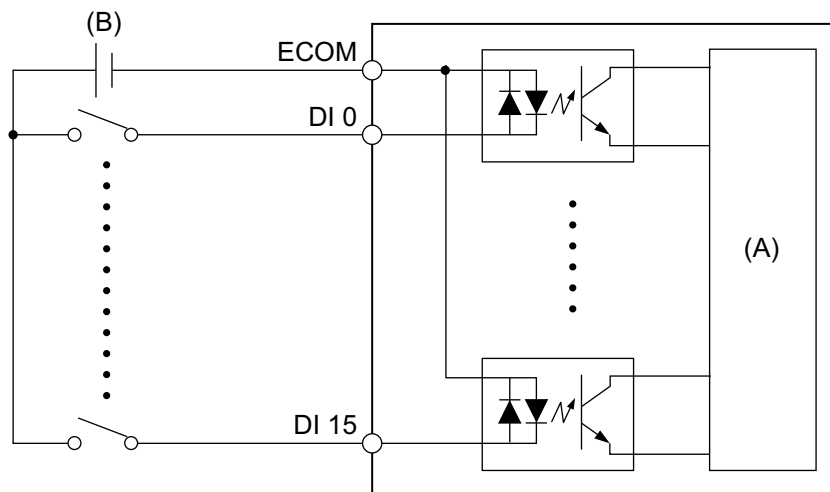

(A) Internal circuit

(B) 24 Vdc

#### Digital input circuit (dry contact)

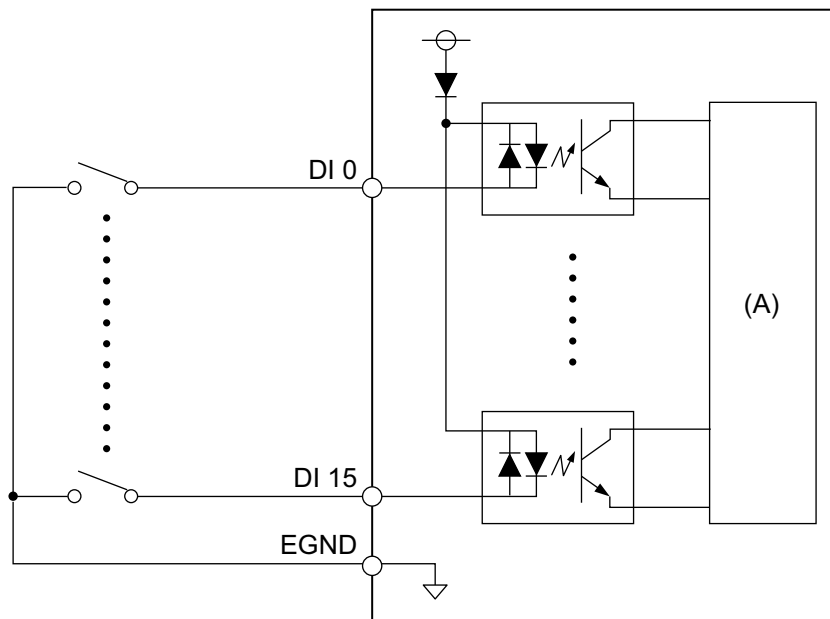

(A) Internal circuit

### Digital output circuit

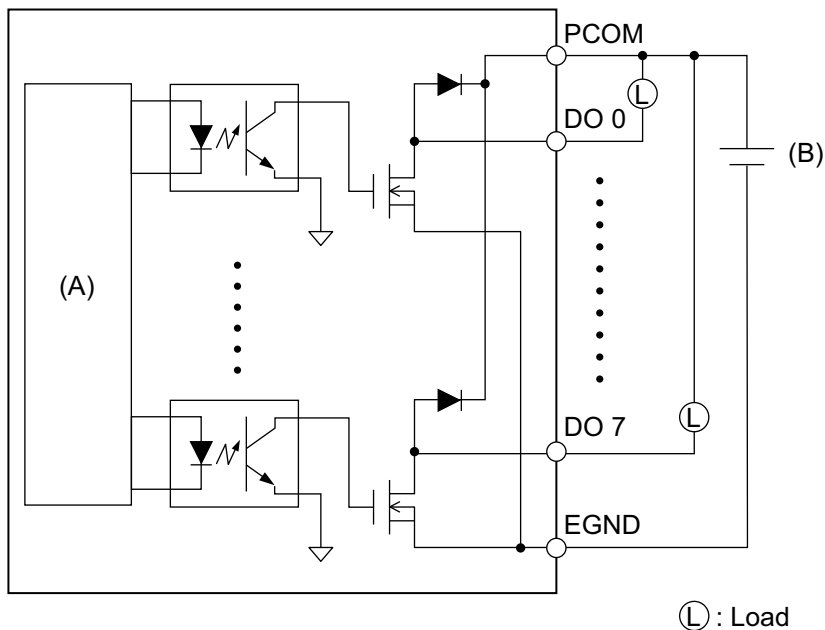

(A) Internal circuit

(B) 24 Vdc

### Wiring of Terminal Box

- If the ends of the individual wires are not twisted correctly, the wires may create a short circuit.
- Using a pin terminal with an insulating sleeve is recommended to prevent the possibility of a terminal short circuit.
- Use copper wire rated for 75 °C (167 °F) or higher.

Recommended cross section	0.5...2.5 mm <sup>2</sup> (AWG 20...13)
Conductor type	Solid or stranded wire
Conductor length	6...7 mm (0.24...0.28 in)
Recommended pin terminals	Cross section: 0.25...1.5 mm <sup>2</sup>
Recommended screwdriver	Blade thickness: 0.6 mm (0.02 in) Blade width: 3.5 mm (0.14 in)

Insert each cord wire into its corresponding hole and fasten the screws to clamp the wire in place.

**NOTE:** The necessary torque is 0.4 N•m (3.5 lb-in).

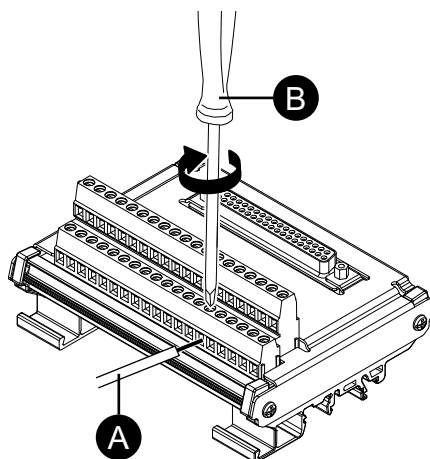

- A. Cord
- B. Screwdriver

### Installing to DIN Rail

Hook the upper groove of the unit onto the DIN rail, then push the bottom part onto the rail until you hear a click.

**NOTE:**

- Use the DIN rail compatible with IEC 60715 TH35-7.5 for the terminal unit.
- In environments where this terminal unit will experience extreme vibration and shock, affix this terminal unit to the DIN rail with compatible fasteners, as required.

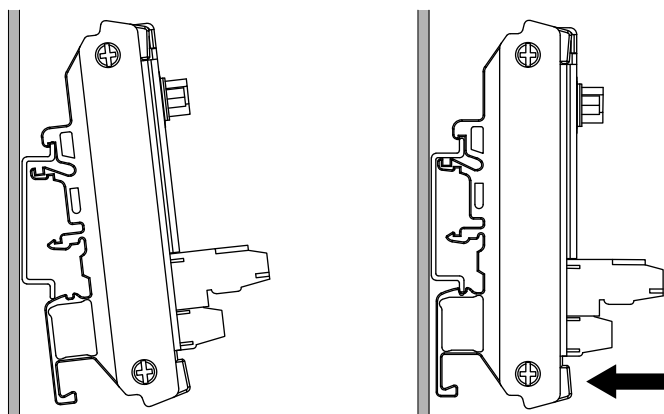

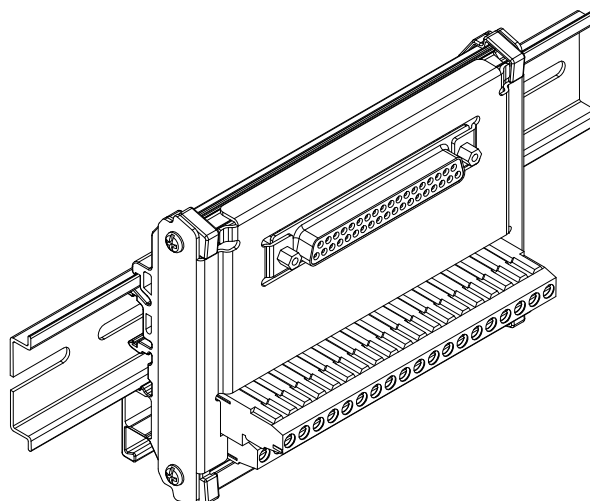

## USB Type A/Type C Cable Clamp

### Attaching USB Cable Clamp

When using a USB device, attach a USB cable clamp to the USB interface to prevent the USB cable from being disconnected.

### **⚠ WARNING**

#### **EXPLOSION HAZARD**

- Verify the power, input, and output (I/O) wiring are in accordance with Class I, Division 2 wiring methods.
- Do not use this product in hazardous environments or locations other than Class I, Division 2, Groups A, B, C, and D.
- Substitution of any components may impair suitability for Class I, Division 2.
- Do not disconnect equipment while the circuit is live or unless the area is known to be free of ignitable concentrations.
- Remove power before attaching or detaching any connectors to or from this product.
- Ensure that power, communication, and accessory connections do not place excessive stress on the ports. Consider the vibration in the environment when making this determination.
- Securely attach power, communication, and external accessory cables to the panel or cabinet.
- Use only commercially available USB cables.
- Use only non-incendive USB configurations.
- Confirm that the USB cable has been attached with the USB cable clamp before using the USB interface.

**Failure to follow these instructions can result in death, serious injury, or equipment damage.**

**NOTE:** Watch your fingers. The edge of the clip is sharp.

1. For USB Type A, mount the clip to the USB mark  on the USB connector shell so that it overlaps. For USB Type C, you can mount it to either side of the connector. For both USB Type A and USB Type C, the clip matches a length of 27 to 43.5 mm (1.06 to 1.71 in) for the USB cable connector.

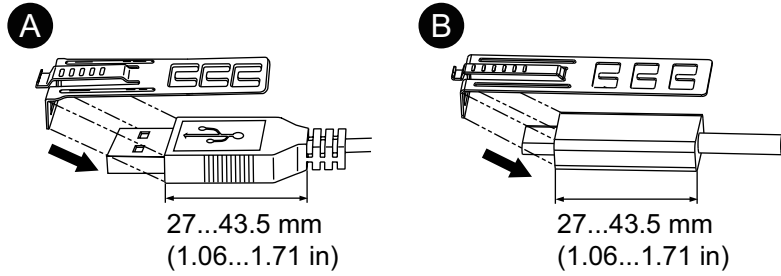

- A. USB Type A
- B. USB Type C

2. Align the clip and the USB cable connector shell. Adjust the position of the holes where the clip is attached. To ensure stability, select the clip-hole position that is closest to the base of the connector shell.

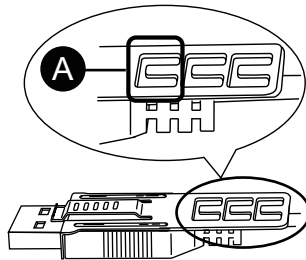

- A. Pass the tie through here.

3. As shown, pass the tie through the clip hole. Next, turn the tie and pass it through the head so that the USB cable can pass through the center of the tie loop. The clip is now attached to the USB cable.

**NOTE:**

- Check the direction of the head beforehand. Make sure the USB cable is through the center of the tie loop and that the tie can pass through the head.
- You can substitute the tie provided with PFXZCCLUSA or PFXYP6CLUSC, or other commercially available ties with a width of 4.8 mm (0.19 in) and thickness of 1.3 mm (0.05 in).

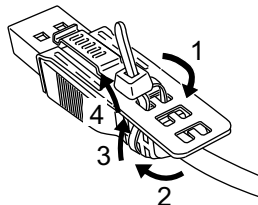

4. While pressing the grip on the clip, insert the cable from step 3 all the way into the USB host interface. Make sure that the tab of the clip is secured to the USB cable attached to this product.

**NOTE:** As shown in the figure below, the location of the notch for USB ports is different between the Advanced Box and Standard Box. Confirm the location of the notch, and insert the tab of the clip.

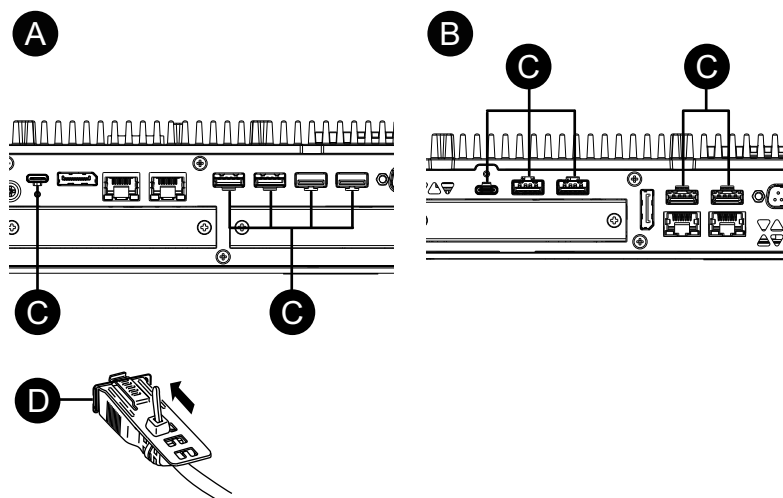

- A. Advanced Box
- B. Standard Box
- C. Notch
- D. USB interface

## Removing USB Cable Clamp

1. Remove the USB cable while pushing the grip section of the clip.

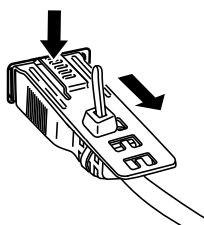

## Front USB Cover

### Opening the Front USB Cover

For 12-inch and 15-inch models, when using a factory-installed front USB cover (without screw), the front surface is rated for IP65F, IP67F, UL 50/50E, or Type 1 enclosure. When using a front USB cover (with screw) (PFXZCDCVUS1), the front surface is rated for IP66F, IP67F, UL 50/50E, Type 1, Type 4X (indoor use only), Type 12 and Type 13 enclosure.

Regardless of using a factory-installed front USB cover or a front USB cover with screw, when the cover is open, the front surface is rated for UL 50/50E and Type 1 enclosure.

**NOTE:** IP65F, IP66F and IP67F are not part of UL certification.



**⚠ CAUTION**

**RISK OF INJURY**

When opening the Front USB Cover, be careful not to injure your fingers.

**Failure to follow these instructions can result in injury or equipment damage.**

**NOTICE**

**BROKEN ENCLOSURE**

Do not exert more torque than the amount specified.

**Failure to follow these instructions can result in equipment damage.**

1. Place your finger or a tool (such as a screwdriver) in the gap on the top of the front USB cover and pull out as illustrated.

**NOTE:**

- When using front USB cover (PFXZCDCVUS1), loosen the top screw using a screwdriver.
- The necessary torque is 0.5 N•m (4.4 lb-in).

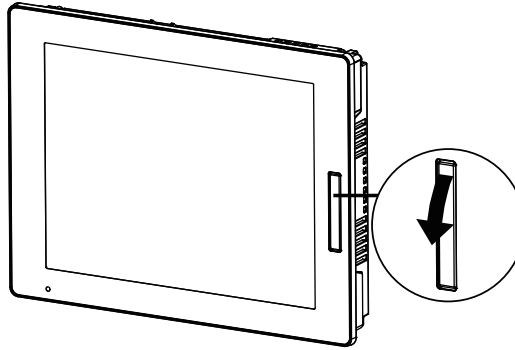

2. The USB interface can be seen once you pull out the front USB cover.

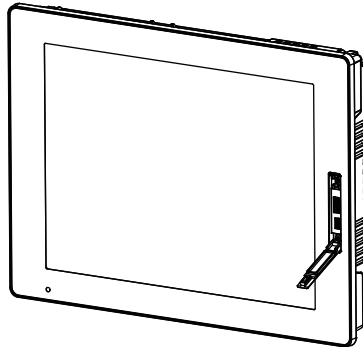

**FAN Kit**

**Introduction**

On the Advanced Box, you can install an optional FAN kit (PFXY6FAN).

Rated input voltage	12 Vdc
Power consumption (max.)	4.08 W

## Installation

**⚡⚠ DANGER****HAZARD OF ELECTRIC SHOCK, EXPLOSION, OR ARC FLASH**

- Remove all power from the device before removing any covers or elements of the system, and prior to installing or removing any accessories, hardware, or cables.
- Unplug the power cable from both this product and the power supply.
- Always use a properly rated voltage sensing device to confirm power is off where and when indicated.
- Replace and secure all covers or elements of the system before applying power to this product.
- Use only the specified voltage when operating this product. The DC model is designed to use 24 Vdc, and the AC model is designed to use 100 to 240 Vac. Always check whether your device is DC or AC powered before applying power.

**Failure to follow these instructions will result in death or serious injury.**

**NOTICE****ELECTROSTATIC DISCHARGE**

Take the necessary protective measures against electrostatic discharge before attempting to remove the cover.

**Failure to follow these instructions can result in equipment damage.**

**NOTICE****BROKEN ENCLOSURE**

Do not exert more torque than the amount specified.

**Failure to follow these instructions can result in equipment damage.**

1. Disconnect the power supply from the Box Module.
2. Touch the housing or ground connection (not the power supply) to discharge any electrostatic charge from your body.
3. Remove 5 screws of the maintenance hatch cover and slide the cover to remove.

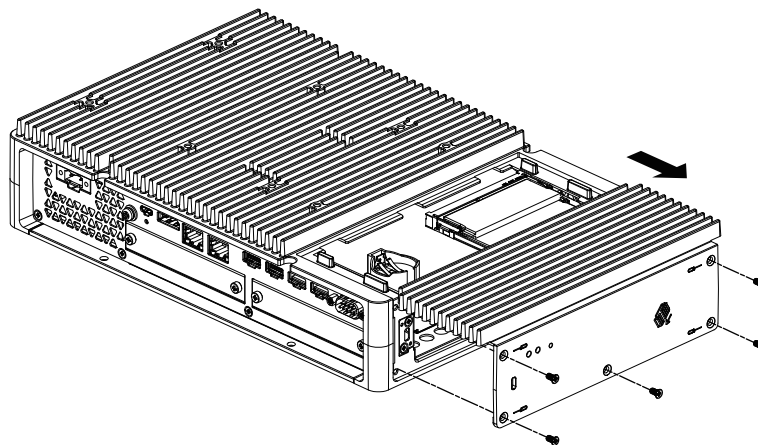

4. When equipped with M.2 SSD, remove the heat sink and heat sink pad (for top) before installing the FAN kit. For information on the heat sink and heat sink pad for M.2 SSD, see M.2 SSD Installation, page 92.

5. Connect the cable of the FAN kit to the connector in the maintenance hatch.

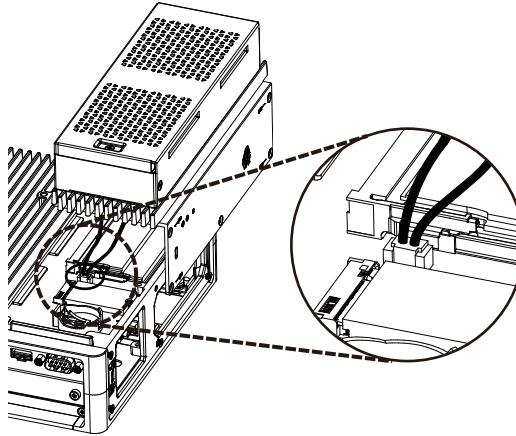

6. Using the screws removed in step 3, secure the FAN kit.

**NOTE:** The necessary torque is 0.3 N•m (2.7 lb-in).

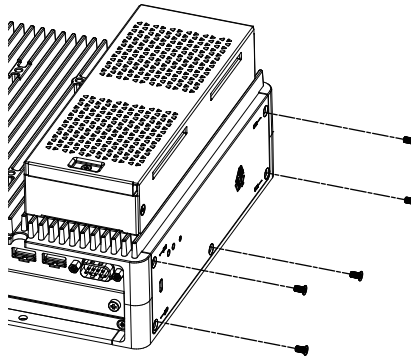

# Maintenance

## What's in This Chapter

Regular Cleaning .....	148
Periodic Check Points.....	148
Replacing the Display Module .....	149
Replacing the Fan Filter .....	151
Replacing the Installation Gasket.....	152
Replacing the Battery and the Backlight .....	153
After-sales Service .....	153

## Regular Cleaning

### Cleaning this product

#### **NOTICE**

##### **EQUIPMENT DAMAGE**

- Power off this product before cleaning it.
- Do not use hard or pointed objects to operate the touch panel.
- Do not use paint thinner, organic solvents, or a strong acid compound to clean the unit.

**Failure to follow these instructions can result in equipment damage.**

When this product gets dirty, wipe this product with a soft, dry cloth or a soft cloth soaked in only water and wrung tightly.

**NOTE:** When the product is very dirty, soak the soft cloth in water with a neutral detergent, wring the cloth tightly and wipe the product while avoiding the product label.

## Periodic Check Points

### Operation Environment

- Is the ambient air temperature within the allowable range? Refer to Environmental Specifications, page 33.
- Is the ambient air humidity within the specified range? Refer to Environmental Specifications, page 33.

When this product is inside a panel, the ambient environment refers to the interior of the panel.

### Electrical Specifications

- Is the input voltage appropriate? Refer to Electrical Specifications, page 29.
- Are all power cords and cables connected properly? Are there any loose cables?
- Are all mounting brackets holding the unit securely?
- Are there scratches or traces of dirt on the installation gasket?

### Unit Disposal

When disposing this product, dispose it in a manner appropriate to, and in accordance with, your country's industrial machinery disposal/recycling standards.

# Replacing the Display Module

## Introduction

When using the Panel Type, you can replace the Display Module with the same display type.

- The following settings are stored on the Display Module. If you replace the Display Module with a new one, these settings return to their factory default settings. For setting up again, refer to *Launcher*, page 157. You can also set the brightness in the Windows® settings.
  - Buzzer
  - Brightness
  - Calibration
  - Front USB
  - Touch Mode
- When the window display position is saved with Window Locker, replacing the Display Module could cause the window to display incorrectly. After replacing the Display Module, save the display position again with Window Locker.

### **DANGER**

#### **HAZARD OF ELECTRIC SHOCK, EXPLOSION, OR ARC FLASH**

- Remove all power from the device before removing any covers or elements of the system, and prior to installing or removing any accessories, hardware, or cables.
- Unplug the power cable from both this product and the power supply prior to installing or removing the product.
- Always use a properly rated voltage sensing device to confirm power is off where and when indicated.
- Replace and secure all covers or elements of the system before applying power to this product.
- Use only the specified voltage when operating this product. The DC model is designed to use 24 Vdc, and the AC model is designed to use 100 to 240 Vac. Always check whether your device is DC or AC powered before applying power.

**Failure to follow these instructions will result in death or serious injury.**

## Removing the Display Module from the Box Module

### **CAUTION**

#### **RISK OF INJURY**

Do not drop the Box Module when you remove it from the Panel Type.

- Hold this product in place after removing the screws.
- Use both hands.

**Failure to follow these instructions can result in injury or equipment damage.**

1. Place the Panel Type on a clean and level surface with the screen facing down.

- Remove the screws (4 pieces) on the rear face, then remove the Box Module.

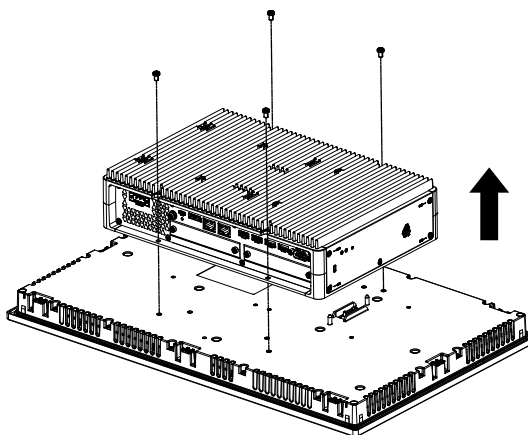

## Installing the Display Module on the Box Module

### **NOTICE**

#### **BROKEN ENCLOSURE**

Do not exert more torque than the amount specified.

**Failure to follow these instructions can result in equipment damage.**

- Place the Display Module on a clean and level surface with the screen facing down.
- Cover the Box Module so that its outline fits in the appropriate guidelines and you can enter the mounting pins through the holes.

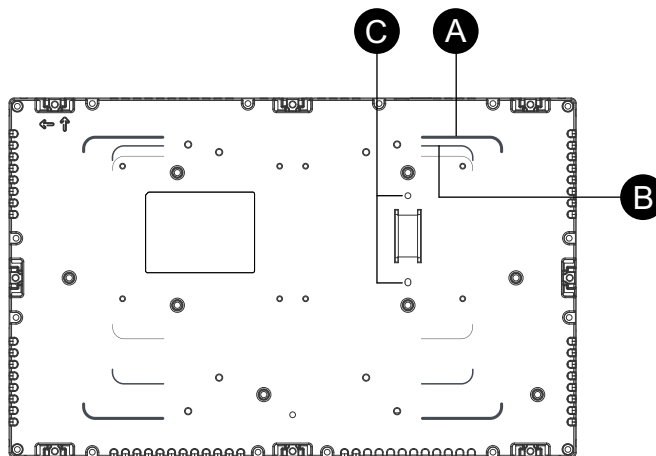

- A. Advanced Box guideline
- B. Standard Box guideline
- C. Installation pins

3. Tighten the M4 screws (4 pieces) to attach the Box Module.

**NOTE:** The necessary torque is 0.7 N•m (6.2 lb-in).

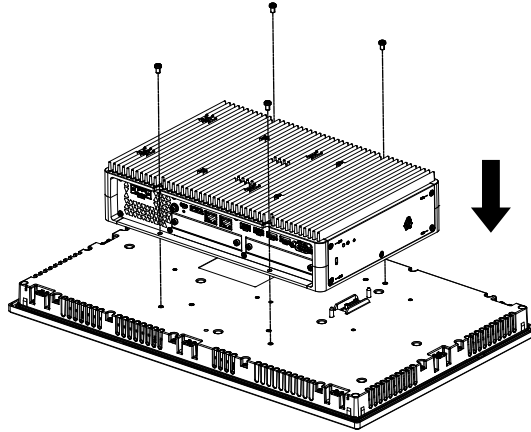

## Replacing the Fan Filter

### Introduction

The following describes how to replace the fan filter in the FAN kit.

**NOTE:** Check the fan filter regularly.

### **⚠️⚠️ DANGER**

#### **HAZARD OF ELECTRIC SHOCK, EXPLOSION, OR ARC FLASH**

- Remove all power from the device before removing any covers or elements of the system, and prior to installing or removing any accessories, hardware, or cables.
- Unplug the power cable from both this product and the power supply prior to installing or removing the product.
- Always use a properly rated voltage sensing device to confirm power is off where and when indicated.
- Replace and secure all covers or elements of the system before applying power to this product.
- Use only the specified voltage when operating this product. The DC model is designed to use 24 Vdc, and the AC model is designed to use 100 to 240 Vac. Always check whether your device is DC or AC powered before applying power.

**Failure to follow these instructions will result in death or serious injury.**

### **NOTICE**

#### **ELECTROSTATIC DISCHARGE**

Take the necessary protective measures against electrostatic discharge before attempting to remove the cover.

**Failure to follow these instructions can result in equipment damage.**

### **NOTICE**

#### **BROKEN ENCLOSURE**

Do not exert more torque than the amount specified.

**Failure to follow these instructions can result in equipment damage.**

## Replacing the Filter

1. Disconnect the power supply from the Box Module.
2. Touch the housing or ground connection (not the power supply) to discharge any electrostatic charge from your body.
3. Remove the screw for the fan filter insert.

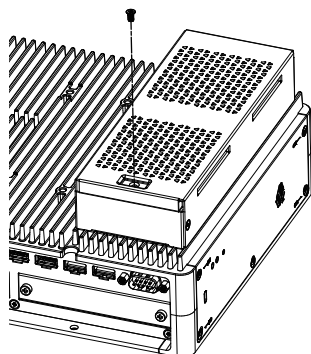

4. Remove the fan filter tray.

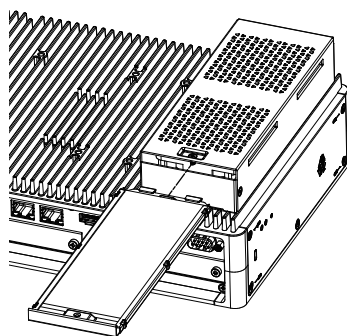

5. Replace the fan filter.

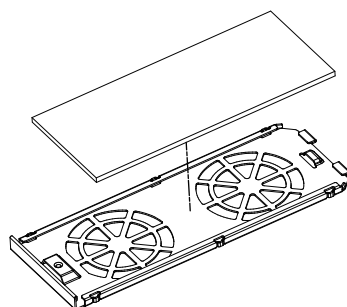

6. Re-insert the fan filter tray and tighten the screw.

**NOTE:** The necessary torque is 0.3 N•m (2.7 lb-in).

## Replacing the Installation Gasket

### Introduction

The installation gasket provides protection against dust and moisture. The gasket must be inserted correctly into the groove for moisture resistance for the Panel Type.



## NOTICE

### GASKET AGING

- Inspect the gasket periodically as required by your operating environment.
- Change the gasket at least once a year, or as soon as scratches or dirt become visible.

**Failure to follow these instructions can result in equipment damage.**

## NOTICE

### EQUIPMENT DAMAGE

Be careful not to stretch the gasket unnecessarily.

**Failure to follow these instructions can result in equipment damage.**

### Installing the Installation Gasket

1. Place the Panel Type on a flat, level surface, with the display face pointing down.
2. Remove the gasket from the Panel Type.
3. Attach the new gasket to the Panel Type. Insert the protrusions from the four corners of the gasket into the corresponding holes in the corners of the Panel Type.

Depending on your model, there may be additional protrusions. In the following, refer to the figure on the right and insert the protrusions accordingly.

**NOTE:** When using a tool to insert the gasket, make sure the tool does not catch the rubber gasket and cause a tear.

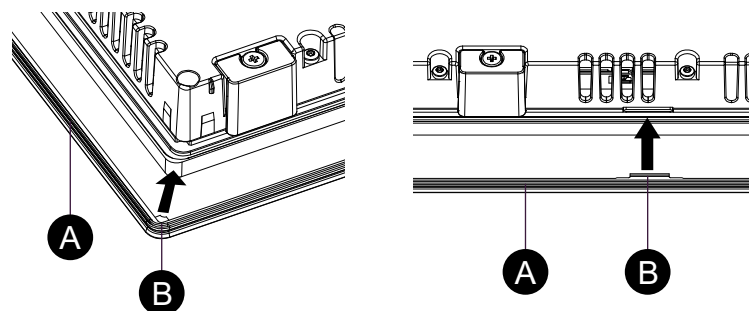

- A. Installation gasket
- B. Protruding point

## Replacing the Battery and the Backlight

Not user replaceable. Please contact customer support.

## After-sales Service

For details on after-sales service, refer to our website.

<https://www.pro-face.com/trans/en/manual/1001.html>

# System Function Settings

## What's in This Chapter

Main Features .....	154
Cybersecurity .....	154
At First Startup .....	155
Windows Update .....	156
UEFI BIOS .....	156
Launcher .....	157
RAID .....	168
System Monitor .....	174
TPM .....	175
McAfee Software .....	175
Backup .....	178
System Recovery .....	179
API .....	181

## Main Features

### Multilanguage Support

The operating system is installed with the following languages.

English (default), Japanese, French, German, Spanish, Italian, Portuguese, Russian, Swedish, Simplified Chinese and Traditional Chinese.

### UEFI BIOS

This product is equipped with the UEFI BIOS. Refer to UEFI BIOS, page 156.

### Launcher

Utility that displays icons for registered files, programs, and various settings, which you can start with a simple touch operation. You can use the Launcher for Write Filter and HORM settings. Refer to Launcher, page 157.

### RAID

This product supports RAID. Supported RAID systems are RAID 0, RAID 1, and RAID 5<sup>\*1</sup>. Refer to RAID, page 168.

<sup>\*1</sup> Supported by Advanced Box only.

### System Monitor

We provide the Node-RED sample dashboard as a system monitor equipped with this product. You can monitor your system with this dashboard. You can also build your own system monitor by editing the flow and creating your own dashboard. Refer to System Monitor, page 174.

### Security Support

Secure Boot is enabled on this product. Additionally, as TPM comes as part of this product, it can easily support an encryption tool, BitLocker. Furthermore, by purchasing a McAfee license you can realize a more secure environment. Refer to TPM, page 175 and McAfee Software, page 175.

**NOTE:** Enable BitLocker to make your system more secure.

## Cybersecurity

It is a fact that Industrial and control systems are more and more vulnerable to cyber attacks due to their modern design:

- They use commercial technologies.
- They are more and more connected.

- They can be remotely accessible.
- Their strategic location in the industrial processes is a point of interest for hackers.

Industrial systems have also different cyber security objectives compared to typical IT systems. To secure properly the industrial installation, it is important to understand these differences. Three fundamental characteristics have to be considered:

- Availability of the system: how to ensure that the system remains operational?
- Integrity of the data: how to maintain the integrity of information?
- Confidentiality: how to avoid information disclosure?

The priorities between an industrial system and a typical IT system are not the same as described on the following diagrams:

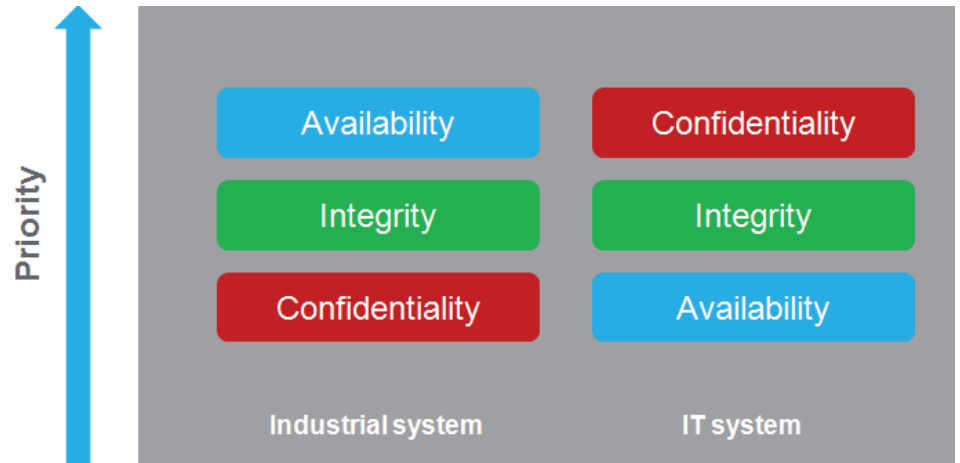

A good recommendation to address these security objectives is to adopt a defense-in-depth approach matching these priorities.

To help keep your Pro-face products secure and protected, we recommend that you implement the cybersecurity best practices. Following the recommendations may help significantly reduce your company’s cybersecurity risk. For the recommendations, refer to the following URL.

<https://www.pro-face.com/trans/en/manual/1087.html>

This product requires the sign-in password to be set in order to reduce the risks of unauthorized access, intrusion and infection of malicious software. Refer to At First Startup, page 155.

**NOTE:** In order to build and operate a secure system, we strongly recommend that you use a different authority account in each phase as follows.

Phase	Account type (authority)
System development	Administrator
Operation	Standard User
Maintenance	Administrator

Use this product in an environment that takes into account the above items to reduce security risks.

## At First Startup

The first time you start up the product, the initial settings for the operating system is executed. Connect a keyboard and mouse before powering up, then follow the on-screen instructions to define the settings.

**NOTE:**

This product requires the sign-in password to be set in order to reduce the risks of unauthorized access, intrusion and infection of malicious software. The conditions for the sign-in password are as follows.

No. of characters: From the usable characters below, at least 3 types and at least 8 characters are required. The sign-in password should not contain the character strings used in the account name.

Usable characters:

- Uppercase letters of European languages (A through Z, with diacritic marks, Greek and Cyrillic characters)
- Lowercase letters of European languages (a through z, sharp-s, with diacritic marks, Greek and Cyrillic characters)
- Base 10 digits (0 through 9)
- Non-alphanumeric characters (special characters): (~!@#%&\*\_+='\|(){}[];:"'<>,.?/) Currency symbols such as the Euro or British Pound are not counted as special characters for this policy setting.
- Any Unicode character that is categorized as an alphabetic character but is not uppercase or lowercase. This includes Unicode characters from Asian languages.

**▲ CAUTION****EQUIPMENT DAMAGE**

Regardless of the Write Filter setting, do not turn off the power immediately after turning on the product.

**Failure to follow these instructions can result in injury or equipment damage.**

**NOTICE****LOSS OF DATA**

Do not turn off the power during initial setup.

**Failure to follow these instructions can result in equipment damage.**

## Windows Update

To use this product more safely, use Windows Update to keep the operating system up to date. Windows Update is disabled in the factory default settings. For the procedure on how to enable, refer to the following URL.  
<https://www.pro-face.com/trans/en/product/1086.html>

## UEFI BIOS

### UEFI BIOS Setup Menu

To enter the UEFI BIOS setup menu:

1. Turn on the product.
2. While the boot screen is displayed, press either the [DEL] or [ESC] key.
3. Enter the password (default password: Pw#12345)\*1.
4. The BIOS screen will display.

\*1 Make sure you change the default password. Refer to Changing the UEFI BIOS Password, page 157.

Depending on the settings, such as Fast Boot, you may not be able to enter the BIOS setup menu using the above procedure. If that is the case, display the setup menu using the following steps.

1. Turn on the product and start up normally.
2. Select the **Settings** button.

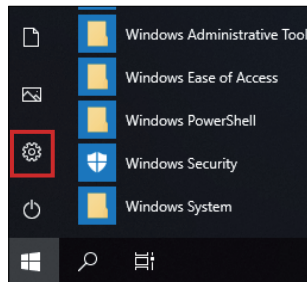

3. Select **Update & Security**.
4. Select **Recovery**.
5. From **Advanced startup**, select **Restart now**.
6. Select **Troubleshoot**.
7. Select **UEFI Firmware Settings**.
8. Select **Restart**.
9. Enter the password (default password: Pw#12345)\*1.

\*1 Make sure you change the default password. Refer to [Changing the UEFI BIOS Password](#), page 157.

## Changing the UEFI BIOS Password

For security reasons, make sure you change the default password (Pw#12345). The following describes the procedure for changing the password.

1. Display the BIOS screen. Refer to [UEFI BIOS Setup Menu](#), page 156.
2. Select **Security**.
3. Select **Administrator Password**.
4. The **Enter Current password** dialog box appears. Enter the current password.
5. The **Create New Password** dialog box appears. Enter the new password.
6. The **Confirm New Password** dialog box appears. Enter the same password as step 5.
7. Press the [F4] key.
8. Select **Yes** in the **Save & Exit Setup** dialog box.
9. The product is restarted.

## Launcher

### Starting the Launcher

The Launcher is a utility that you can set up to start programs and settings. The Launcher allows for convenient touch-screen operation by displaying icons for registered various settings.

You can start the Launcher from the shortcut icon on the desktop.

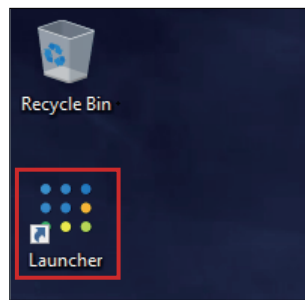

Launcher top screen

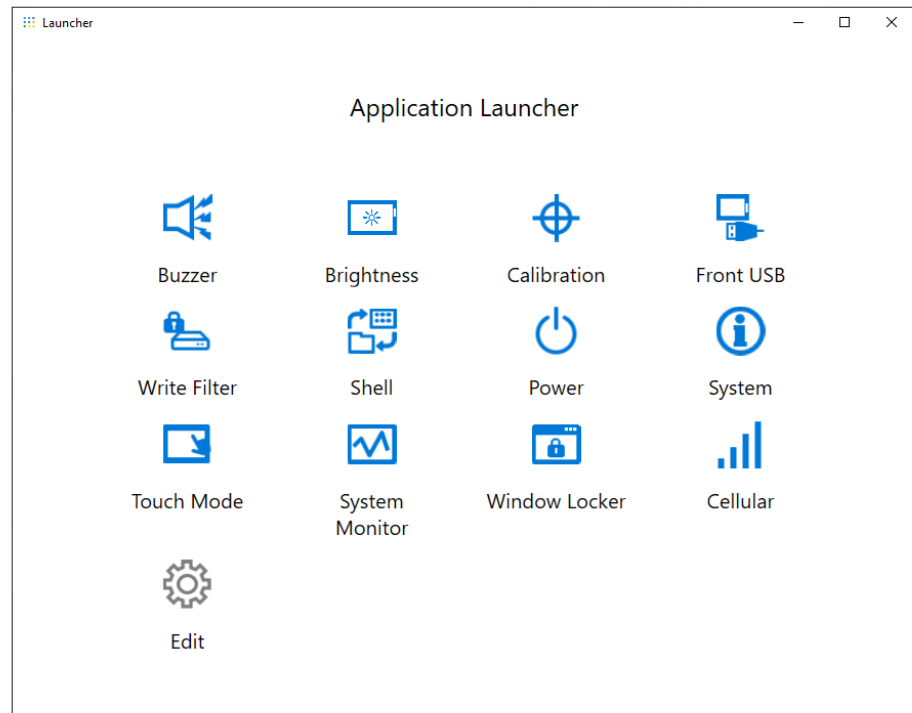
**NOTE:**

- To customize the Launcher, refer to Edit, page 167.
- If you download the utility (PFXPHMIP6\_Utility\_Installer\_Ver.x.x.zip) from our website and install it, the Launcher is overwritten. Customize the Launcher again, as required, referring to Edit, page 167.  
<https://www.pro-face.com/trans/en/manual/1085.html>

**Buzzer**

Sets the sound on/off when you perform touch-panel operations.

Default: **On**

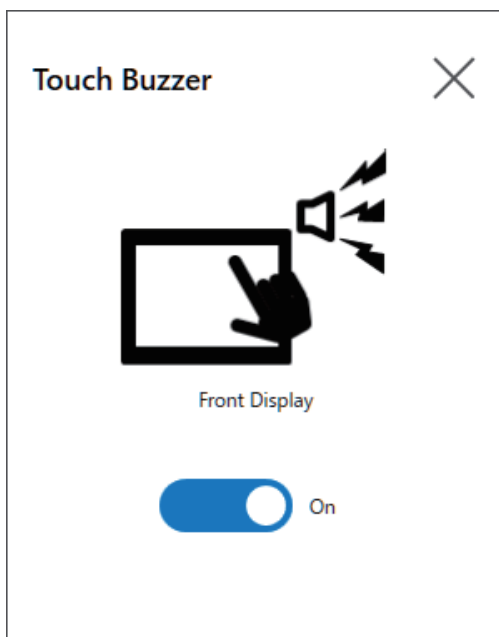

## Brightness

Sets the backlight brightness.

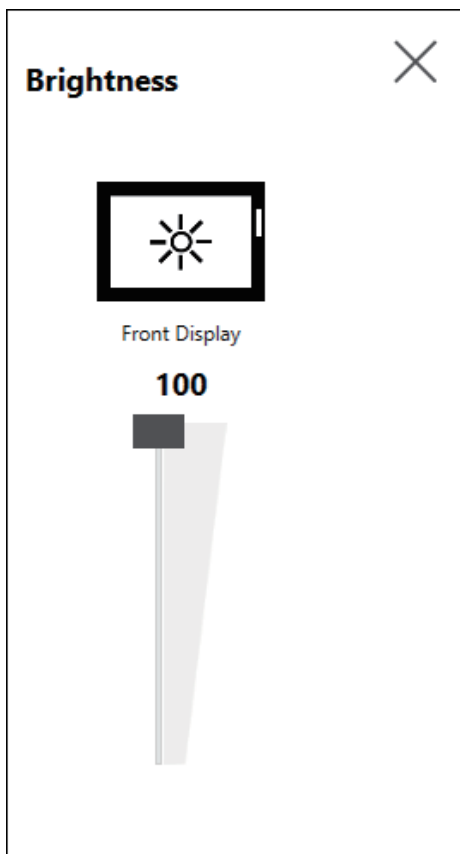

## Calibration

Calibrates the touch coordinates.

**NOTE:**

- Do not calibrate using the Control Panel **Tablet PC Settings > Adjustment**. If touch panel calibration is required, use the calibration method shown here.
- Before running calibration, in the Windows display settings set the [Scale and layout] to 100% for the associated display. You cannot calibrate properly using other scaling settings.

Calibration screen instructions are different between analog resistive film and projected capacitive (P-CAP) displays. Perform calibration as per the screen instructions.

### Analog resistive film display

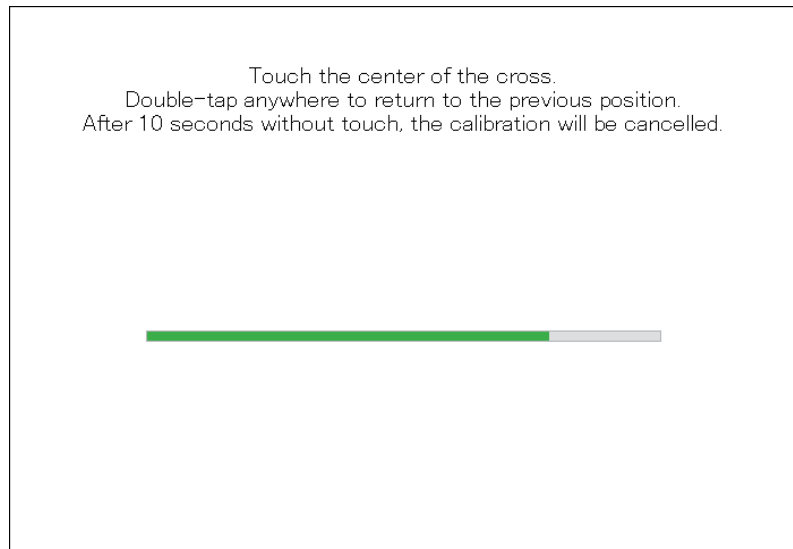

### Projected capacitive display

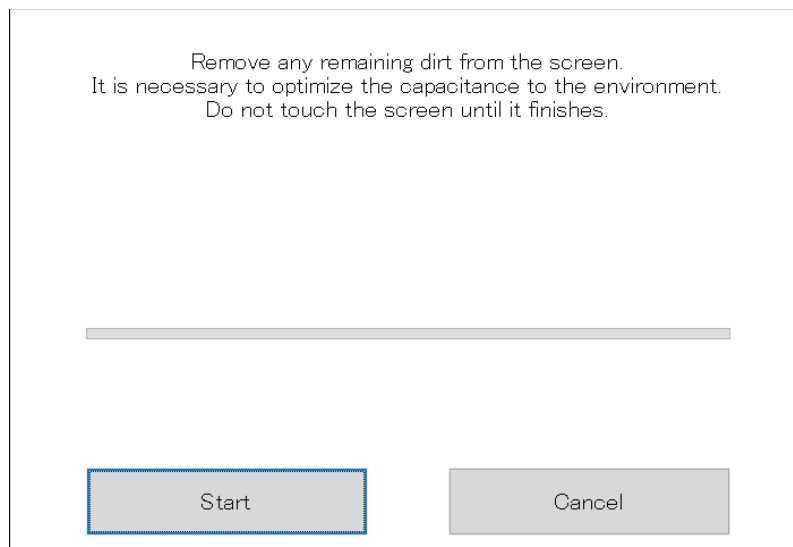

## Front USB

Enables/disables the front USB port on the Display Module.

Default: **Off** (Disable)

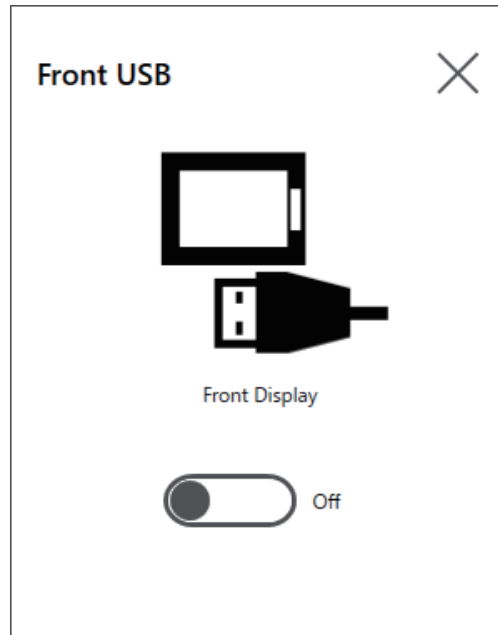

**NOTE:**

- If the front USB is enabled, the risk of unauthorized access and infection of malicious software increases. Disable the front USB after use.
- In models without a front USB port, this setting is disabled.

**Write Filter**

This function prevents writing to the system disk.

By enabling the Write Filter, you can prevent damage to the system disk and shortened life of disk due to excessive writes. Also, enabling the Write Filter allows you to turn off the power to this product without shutting it down. However, the write operation can occur right after restarting the product, even if the Write Filter is enabled, due to a characteristic of Windows®. Do not turn off this product right after restarting it.

Default: **Off** (Disable)

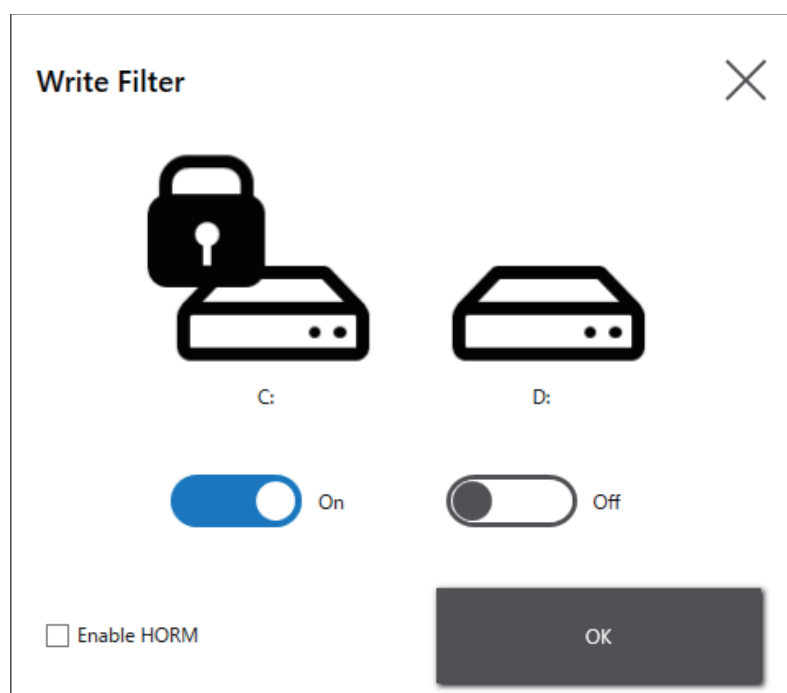

**NOTE:**

- When only one volume is set to the Write Filter, the screen displays just that one volume.
- When changing settings (such as settings in the Launcher, RAID, and when adding drivers, changing the registry, or installing applications), disable the Write Filter. If the Write Filter is enabled, any changes to settings will be erased when the operating system is restarted. After changes to settings are complete, we recommend that you re-enable the Write Filter.
- If the Write Filter is enabled, the fast startup function is disabled.

**⚠ CAUTION****EQUIPMENT DAMAGE**

Regardless of the Write Filter setting, do not turn off the power immediately after turning on the product.

**Failure to follow these instructions can result in injury or equipment damage.**

**NOTICE****LOSS OF DATA**

Do not turn off the power while writing to a storage device that is not protected by the Write Filter.

**Failure to follow these instructions can result in equipment damage.**

**HORM**

This feature shortens the product's start time.

If you save a system state with HORM enabled, it is possible to restore the system to this saved state even after power to this product is turned off. If HORM is enabled, you need to enable the Write Filter as well. By doing so, you can turn off the power to this product without performing a shutdown.

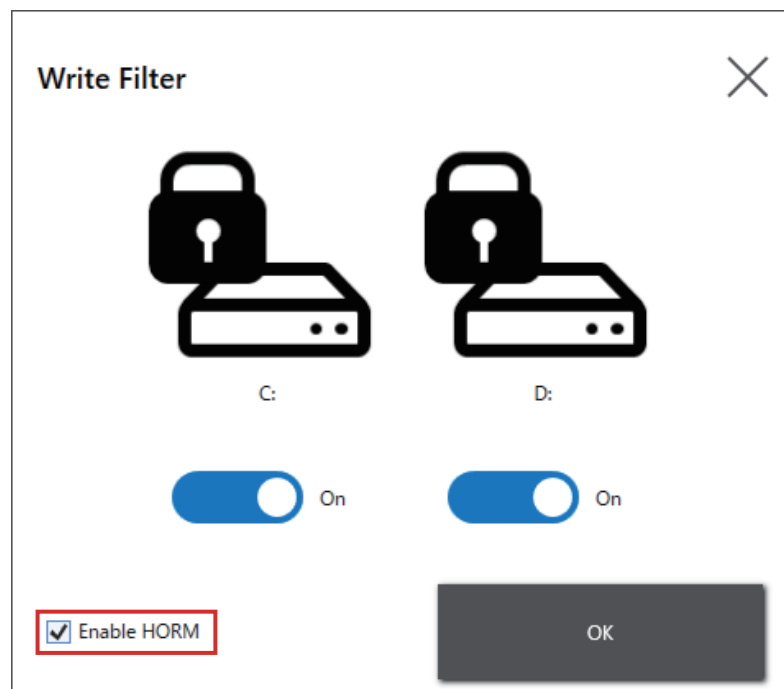

**NOTE:**

- Before setting up HORM, enable the Write Filter on all volumes.
- Removable disks are not supported for use with HORM. Before setting up HORM, detach all removable disks.
- When HORM is enabled, the LED on the Display Module turns orange right away, but turn off the power only after confirming the power LED on the Box Module has turned red.
- When HORM is enabled or immediately after hibernation, system backup or recovery will not run properly. Perform system backup or recovery after first disabling HORM and then shutting down the product.
- If a system configured at hibernation or with HORM enabled is stored on a system disk, do not use that system disk on a different Box Module unit.

**⚠ CAUTION****EQUIPMENT DAMAGE**

Regardless of the Write Filter setting, do not turn off the power immediately after turning on the product.

**Failure to follow these instructions can result in injury or equipment damage.**

**NOTICE****LOSS OF DATA**

Do not turn off the power while writing to a storage device that is not protected by the Write Filter.

**Failure to follow these instructions can result in equipment damage.**

**Shell**

You can hide the Windows® desktop by switching from the Explorer Shell to the Custom Shell. By doing so, you can suppress Windows® functions such as the Control Panel.

Custom Shell: The Windows® desktop is not displayed.  
Explorer Shell: The Windows® desktop is displayed.

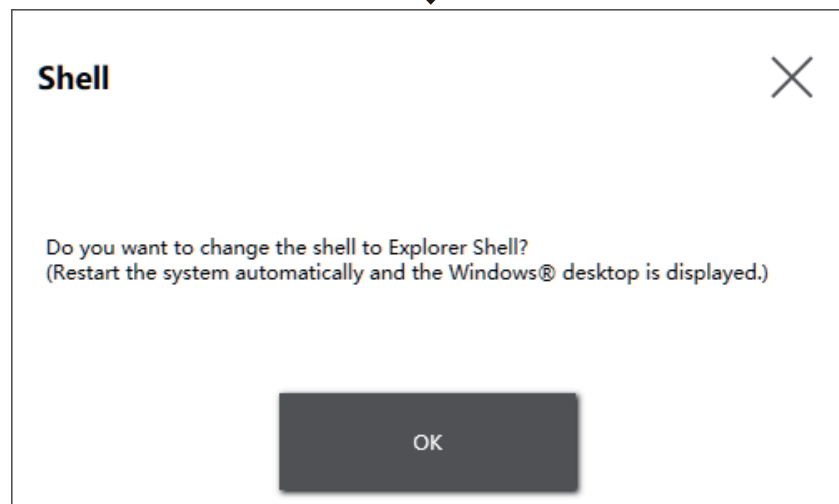
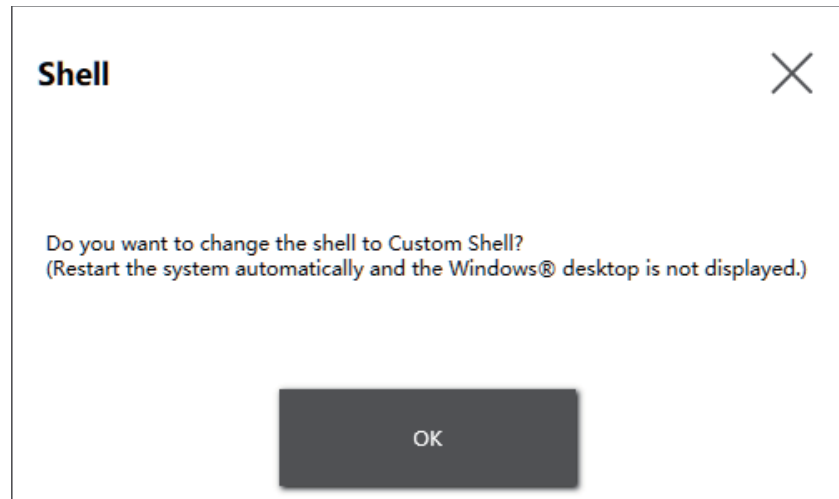

**NOTE:**

- Install applications in the Explorer Shell.
- When changing to the custom shell, the features shown in the Explorer Shell (such as Windows® desktop, Start menu, taskbar) cannot be used.

## Power

Use this feature to operate the product's power supply .

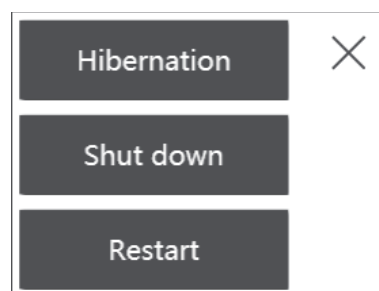

**NOTE:** With HORM enabled, using the Hibernation icon to hibernate the operating system will overwrite the previously saved state in HORM with the current system state. When you reboot the system, the system starts up in the state saved at hibernation. After that, even with HORM enabled if the power is shut off, the system returns to the state saved at hibernation.

## System

Displays the version of the product firmware, BIOS, and operating system.

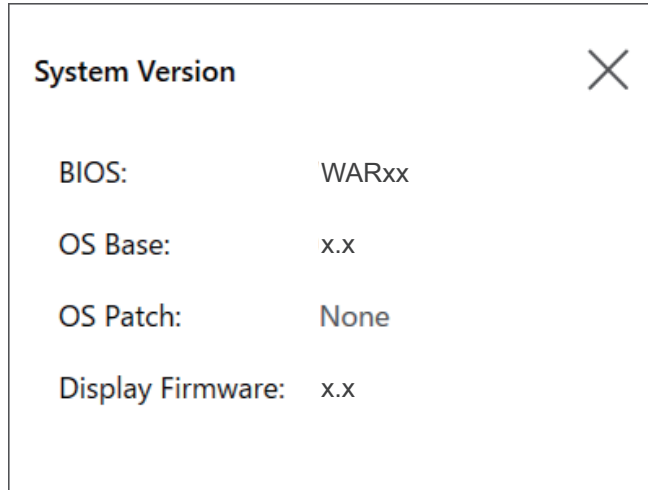

## Touch Mode

The following three modes are available to support your usage environment. Select the mode according to your usage environment.

**NOTE:** This function is available only on the models with a projected capacitive touch panel.

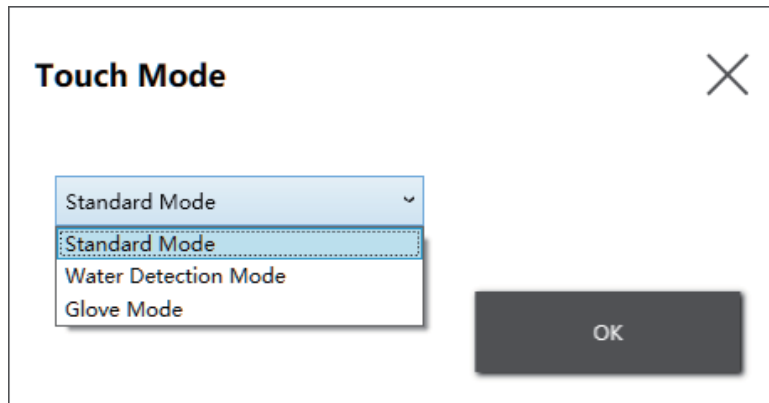

Standard Mode	Factory default. Suitable for touch operations using your finger.
Water Detection Mode	Mode where touch input becomes disabled when there are liquids, such as drops of water, on the screen. Suitable to prevent touch panel mis-operation due to liquids on the screen. After wiping the liquid or other foreign substance from the screen, touch input becomes enabled in about 2 seconds.
Glove Mode	Mode suitable for use with gloves, such as rubber gloves. <b>NOTE:</b> <ul style="list-style-type: none"> <li>Depending on the type of glove, operation may not be possible.</li> <li>Because touch sensitivity is increased in this mode, it is more susceptible to environmental noise.</li> </ul>

## System Monitor

This icon displays the system monitor. For information, refer to *System Monitor*, page 174.

## Window Locker

If for some reason the connection to the external display is disconnected, the displayed application window may move to a different position or to a different display altogether. By using the Window Locker, when applications start up you can display them in a fixed position, so that after reconnecting external displays you can view the application window in the same display and position as before being disconnected.

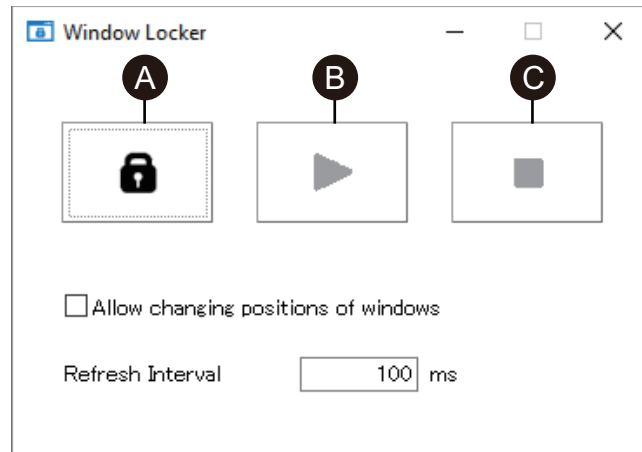

- A. LOCK
- B. PLAY
- C. STOP

1. Start up all application windows to define their display positions and which display to use.

**NOTE:** If you save the display position while the application is in full screen mode, the window may not display properly.

2. Move each window to the desired display position.
3. Run Window Locker from the Launcher.
4. Select **LOCK** to save the display position.

**NOTE:**

- Window sizes are fixed to the size when **LOCK** is pressed.
  - By entering an amount of time in the **Refresh Interval**, if you change the window size or position after **PLAY** is pressed, the window will return to its original size and position when the time elapses. If you select the **Allow changing positions of windows** check box, after **PLAY** is pressed, even when the entered time elapses the window will remain in the changed position, but the window will return to its original size.
  - The **Refresh Interval** input range is from 100 ms to 86,400,000 ms (24 hours).
5. Select **PLAY**. Every time the application window opens, it automatically appears in the saved position.

**NOTE:**

- When saving window positions, ensure that the Write Filter is disabled. If the Write Filter is enabled, the saved information will be erased when the operating system is restarted. After you finish saving, we recommend that you re-enable the Write Filter.
- To temporarily release the fixed position, select **STOP**. To return to the fixed position, select **PLAY**.
- After saving the window display position, connecting or disconnecting an external display loses the display positions. If you add a connection or disconnect, save the display position again. However, if you return to the same configuration as before connecting or disconnecting the external display, the saved display position information is applied so you do not have to set the display information again.
- You may not be able to normally save the display position of windows with the same name, or applications such as Windows® Media Player, which have multiple internal windows.
- After saving the window display position with Window Locker, changing the screen placement or resolution could cause the window to display incorrectly. If you change the screen settings, save the window display position again.

**Cellular**

You can use the optional interface unit and a SIM card to data communication using 3G, 4G, and LTE radio waves. Double-click this icon to make settings for data communication.

For information how to enable data communication, refer to [4G Cellular Settings](#), page 131.

**Edit**

You can use this function to customize the icons displayed on the Launcher. You can also add any application to the display.

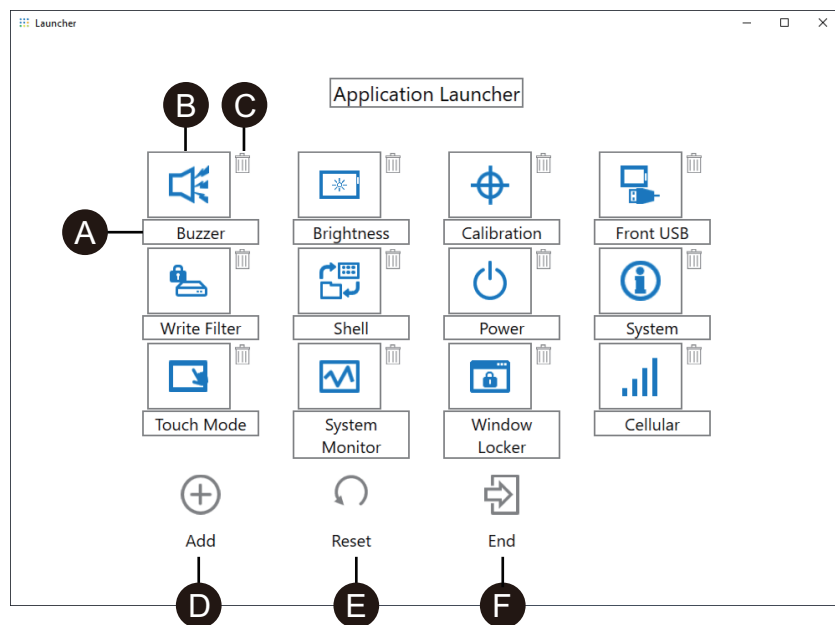

- You can change the name of the icon.
- You can change the application displayed. Click to display a screen where you can select the application's exe file. Select the exe file of the application you want to display.

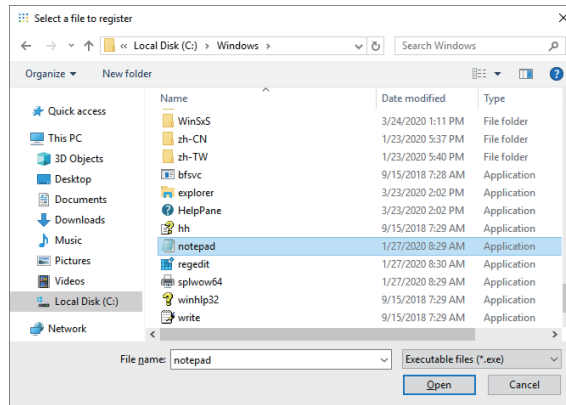

- C. Click this mark to remove the icon.
- D. Add the application displayed. Click to display a screen where you can select the application's exe file. Select the exe file of the application you want to display.
- E. Returns the icon display to the factory default settings.
- F. This button releases Edit mode.

## RAID

### RAID Levels

This product supports RAID. Supported RAID levels are as follows.

RAID 0

RAID 1

RAID 5 (supported only on Advanced Box)

#### NOTE:

- Hot swap is supported.
- When configuring RAID 5, an optional storage device is required. Refer to Accessories, page 20.

### ⚠ WARNING

#### EXPLOSION HAZARD

Never attempt to perform hot swap in hazardous locations.

**Failure to follow these instructions can result in death, serious injury, or equipment damage.**

### ⚠ CAUTION

#### RISK OF INJURY OR EQUIPMENT DAMAGE

Do not touch the electronic boards while energized.

**Failure to follow these instructions can result in injury or equipment damage.**

### RAID Configuration

When configuring RAID, including the operating system area, recovery media is required. Either purchase the optional Recovery USB (PFXYP6RUSW10), or prepare a commercially available USB memory and create a backup USB.



**NOTE:** The optional Recovery USB recovers the operating system only. If you require backup in addition to recovery of the operating system, refer to Backup, page 178.

## RAID Setup (System Version 1.1 or later)

The RAID set up process differs depending on the system version. You can check the system version from the Launcher. Refer to System, page 165.

The following describes the setup process when OS Base is version 1.1 or later.

**NOTE:**

- In case of data corruption, we recommend preparing recovery media.
- For information on working with Intel® Optane™ Memory and Storage Management, refer to the application online help.
- If you configure RAID with M.2 SSD 128 GB and the M.2 SSD 128 GB needs to be replaced, replace it with the same type, M.2 SSD 128 GB. If Standard Endurance was used before, use Standard Endurance; if High Endurance was used before, use High Endurance.

### Setting Procedure

1. Turn on the product.
2. While the boot screen is displayed, press either the [DEL] or [ESC] key.
3. Enter the password (default password: Pw#12345).
4. The BIOS screen is displayed.
5. From the **Advanced** tab, select **SATA Configuration**.
6. Select **SATA Mode > RAID**.
7. Press the [F4] key.
8. Select **Yes** in the **Save & Exit Setup** dialog box.
9. Start up Intel® Optane™ Memory and Storage Management.

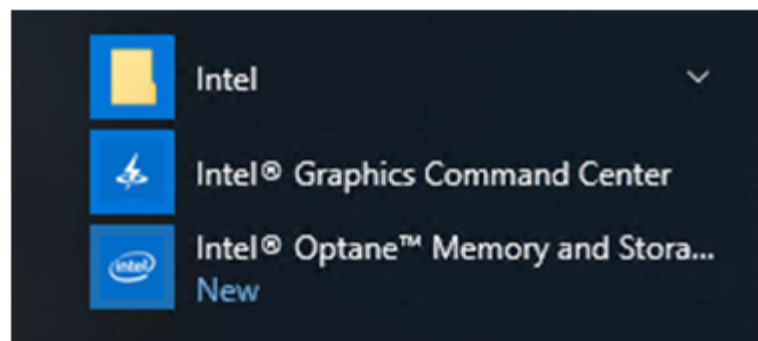

10. Select **Create RAID Volume** and follow the instructions to configure RAID. Select a RAID level. For supported RAID levels, refer to RAID Levels, page 168.

The screenshot shows the 'Create RAID Volume' window in the Intel Optane Memory and Storage Management application. The window title is 'Intel® Optane™ Memory and Storage Management'. On the left, there is a navigation pane with options: Manage, Create RAID Volume (selected), Intel® Optane™ Memory, Performance, Settings, and About. The main area is titled 'Create RAID Volume' and contains the following fields and options:

- Name:
- Select controller:
  - PCIe
  - SATA
- Select volume type:
  - Optimized disk performance (RAID 0)
  - Real-time data protection (RAID 1)
  - Efficient data hosting and protection (RAID 5)
  - Balanced performance and data protection (RAID 10)
- Proposed Configuration (pop-up window):
  - Protection:
  - Performance:
  - Capacity:
  - Text: Combine two or more disks to create a volume where data is broken down into stripes that are distributed across all disks.
- Next button

The screenshot shows the 'Create RAID Volume' window in the Intel Optane Memory and Storage Management application, continuing from the previous step. The window title is 'Intel® Optane™ Memory and Storage Management'. The navigation pane is the same. The main area is titled 'Create RAID Volume' and contains the following fields and options:

- Select array disks:
  - SATA disk on Controller 0, Port 1 (238 GB) (System)
  - SATA disk on Controller 0, Port 2 (238 GB)
- Keep the data from one of selected disks?
  - No
- Volume Size: 0 Bytes
- Array allocation: 0% (with a slider)
- Data stripe size:
- Enable volume write-back cache
- Back and Next buttons
- Proposed Configuration (pop-up window):
  - volume\_0000
  - Type: RAID 0

11. The following screen is displayed. Check the message and enable **Delete data on**. Then select **Create RAID Volume**.

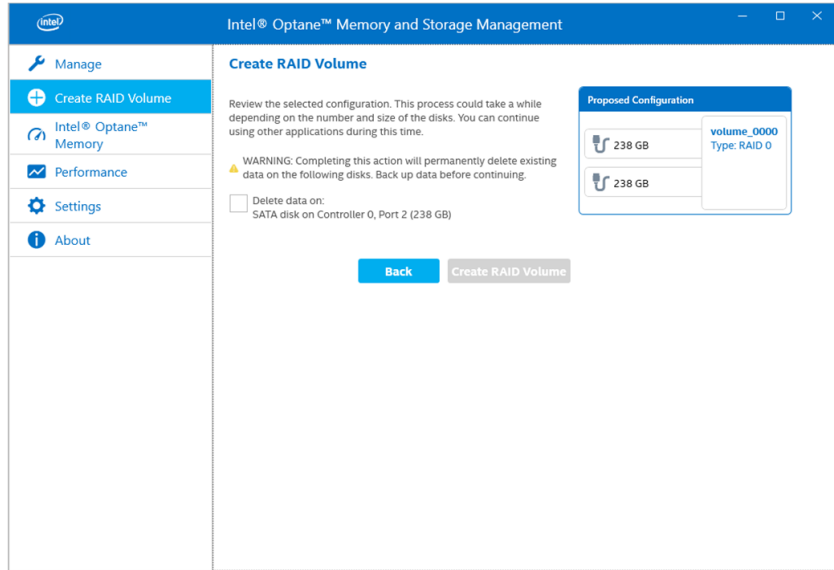

12. The percentage of creating a RAID Volume is displayed as follows. When the percentage display disappears, the process is complete.

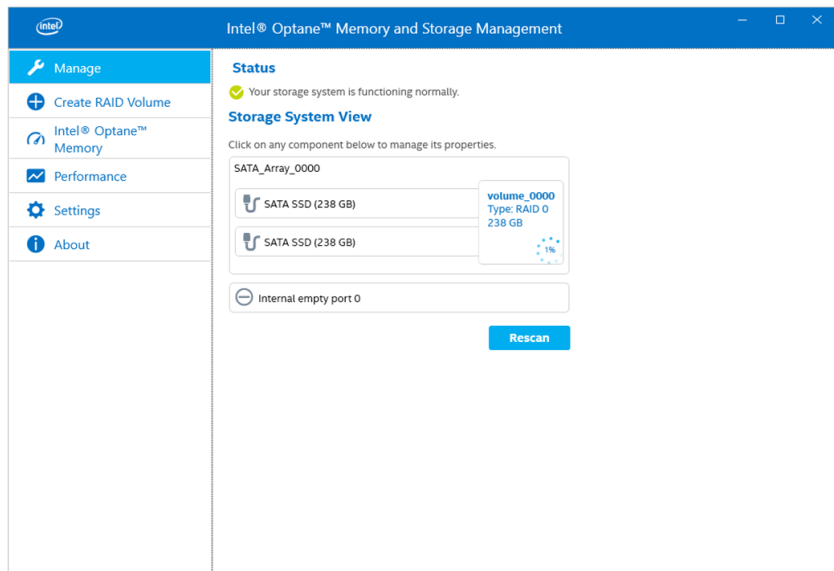

## RAID Setup (System Version 1.0)

The RAID set up process differs depending on the system version. You can check the system version from the Launcher. Refer to [System](#), page 165. The following describes the setup process when OS Base is version 1.0.

**NOTE:**

- In case of data corruption, we recommend preparing recovery media.
- For information on working with Intel® Rapid Storage Technology, refer to the application online help.
- If you configure RAID with M.2 SSD 128 GB and the M.2 SSD 128 GB needs to be replaced, replace it with the same type, M.2 SSD 128 GB. If Standard Endurance was used before, use Standard Endurance; if High Endurance was used before, use High Endurance.

1. Turn on the product.
2. While the boot screen is displayed, press either the [DEL] or [ESC] key.

3. Enter the password (default password: Pw#12345).
4. The BIOS screen is displayed.
5. From the **Advanced** tab, select **SATA Configuration**.
6. Select **SATA Mode > RAID**.
7. Press the [F4] key.
8. Select **Yes** in the **Save & Exit Setup** dialog box.
9. The product is restarted.
10. Start up Intel® Rapid Storage Technology.

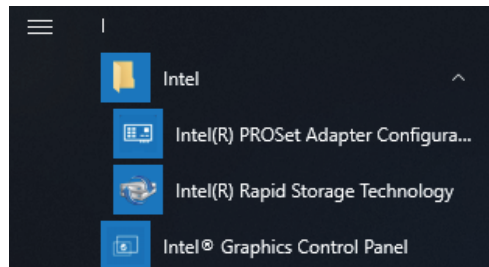

11. Select **Create a custom volume**.

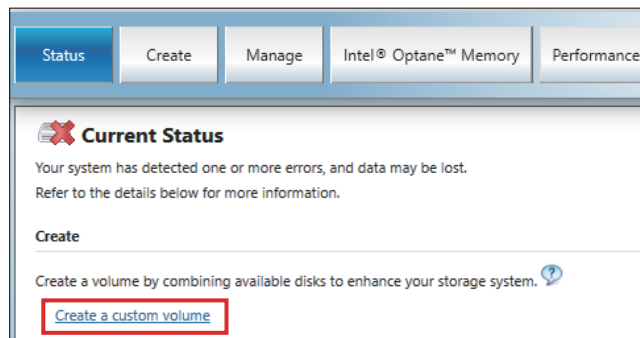

12. The following screen is displayed. Follow the instructions to configure RAID.

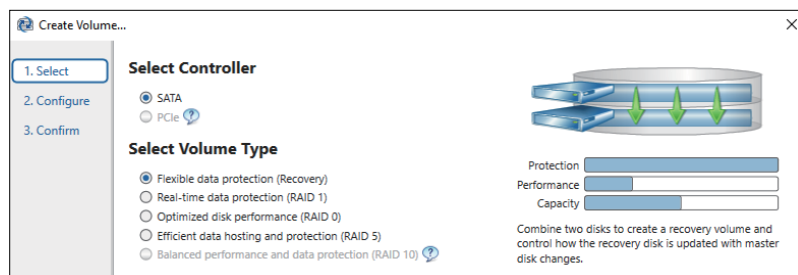

13. The following screen displays, as the data is still being migrated. Select **OK** and check the progress shown on the screen.

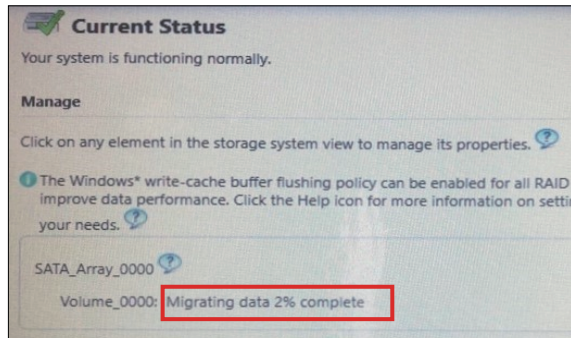
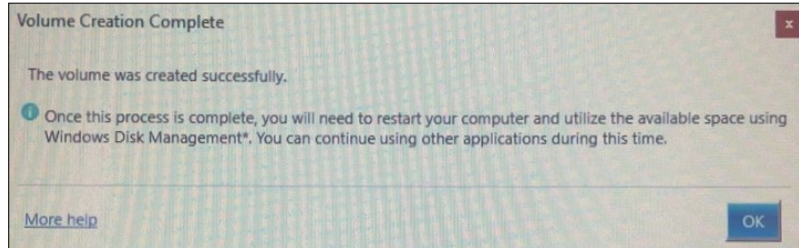

## Deleting RAID settings

1. Turn on the product.
2. While the boot screen is displayed, press either the [DEL] or [ESC] key.
3. Enter the password (default password: Pw#12345).
4. The BIOS screen is displayed.
5. From the **Advanced** tab, select **Intel® Rapid Storage Technology**.
6. Select the volume that has RAID set up.
7. Select **Delete**.
8. Select **Yes**.
9. Press the [ESC] key to return to the BIOS tab selection screen.
10. Select **SATA Configuration**.
11. Select **SATA Mode > AHCI**.  
**NOTE:** If the configured RAID does not include the operating system, perform steps 13 and 14 to complete this operation.
12. Insert recovery media.
13. Press the [ESC] key to return to the BIOS tab selection screen, and select the **Save & Exit** tab.
14. Select **Save Changes and Reset > Yes**.
15. While rebooting, press the [F7] key.
16. For subsequent steps, continue from step 4 of the System Recovery procedure. Refer to System Recovery, page 179.

# System Monitor

## How to Run System Monitor

This product comes with our original system monitor—a dashboard created with Node-RED. You can run the system monitor from the System Monitor icon in the Launcher.

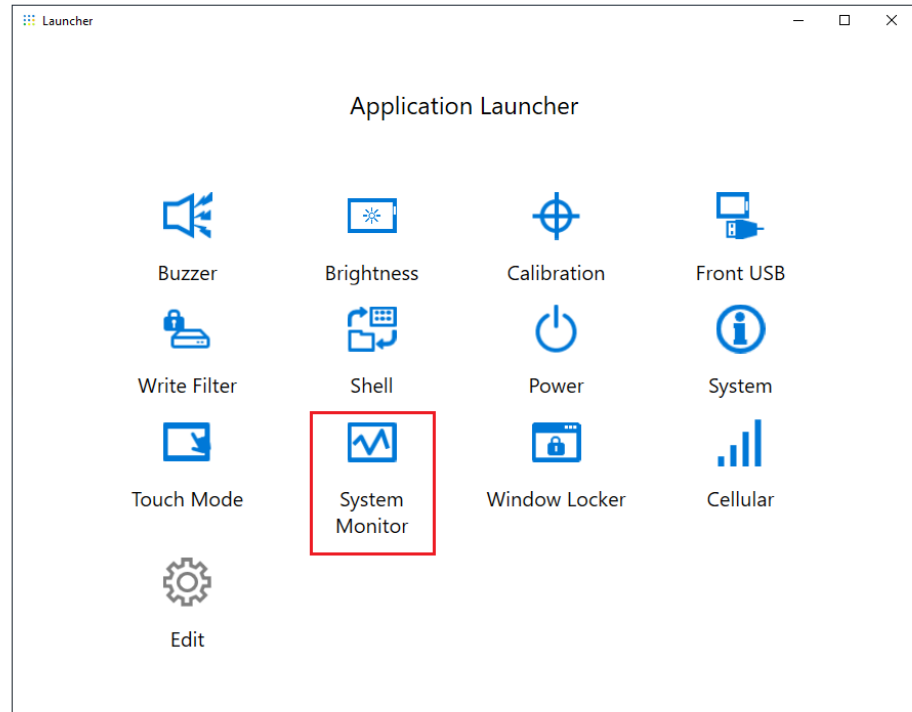

The first time System Monitor is started, the Windows® Internet Explorer settings screen will appear. The Windows Security Alert screen will also appear. Select **Allow access** if you allow other computers on the network to use the dashboard; select **Cancel** if you do not.

**NOTE:** When deciding whether to allow access, keep security under careful consideration.

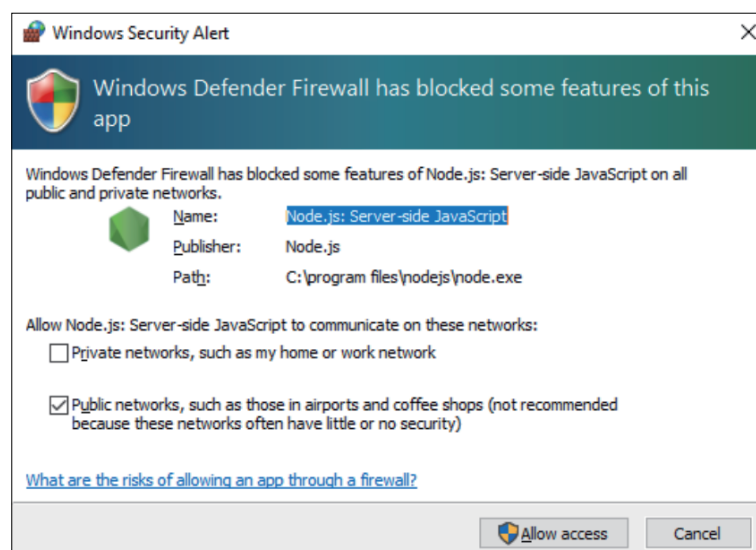

## Node.js and Node-RED Update

Always use the latest versions of Node.js and Node-RED. For the procedure on installing the latest version, refer to the following URL.

<https://www.pro-face.com/trans/en/product/1086.html>

## Change Access Rights for Node-RED Related Files

To use Node-RED more safely, set so that using Node-RED related files requires Administrator rights. For the setup method, refer to the following URL.

<https://www.pro-face.com/trans/en/product/1086.html>

## Editing and Creating Dashboards

The latest version of the dashboard provided by us is published at the following URL. Download as required. You can also edit the dashboard or create a new one. For the editing process, refer to the following URL.

<https://www.pro-face.com/trans/en/product/1086.html>

## System Monitor API

The API is published on our website. For the file to download, refer to API, page 181.

## TPM

This product comes equipped with the TPM 2.0 module.

Enable or disable TPM in accordance with the laws, regulations, and standards of each country.

TPM is enabled by default.

**NOTE:** Enable BitLocker to make your system more secure.

### TPM Setup Process

1. Turn on the product.
2. To disable TPM, press [CTRL]+[D]; to enable TPM, press [CTRL]+[E].
3. After the setting is updated, the boot screen displays either **TPM Disabled** or **TPM Enabled**.

```
Press <DEL> or <ESC> to enter setup.  
TPM Disabled.  
Press F2 to reset system.
```

```
Press <DEL> or <ESC> to enter setup.  
TPM Enabled.  
Press F2 to reset system.
```

## McAfee Software

### Introduction

By purchasing the optional McAfee license (PFXYP6LSMCA) and using the McAfee software, you can increase the security on this product. For the software

functions and how to use the software, refer to the following URL and search for the associated manual.

<https://docs.mcafee.com/bundle>

The following describes how to install the software and search for the manual.

## Installation

1. Insert the McAfee license USB storage to the product.
2. Run **setup.exe** in USB storage.
3. The installer is executed.

## Searching for the Manual

The following describes how to search for the McAfee software manual. Check the software version beforehand.

1. Select the **Settings** button.

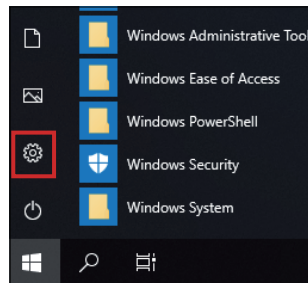

2. Select **App**.
3. In **Apps & features**, select **McAfee Solidifier**.

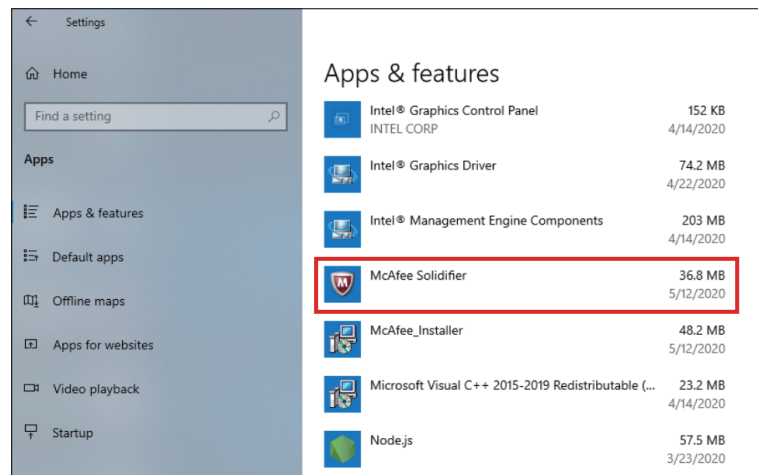

4. Confirm the version.

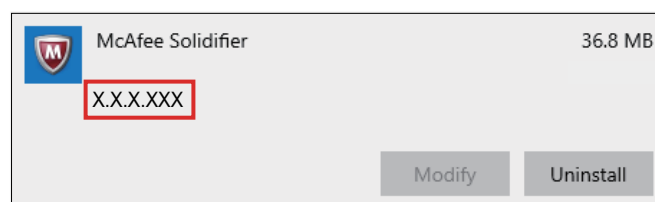

5. Close the **App** screen.



6. Display <https://docs.mcafee.com/bundle> in the web browser.
7. Search for the corresponding version of the **McAfee Application Control** manual.

## Uninstallation

When uninstalling, you need to uninstall the following two applications.

- McAfee Solidifier
- McAfee Installer

Steps for uninstalling is as follows.

1. Select the **Settings** button.

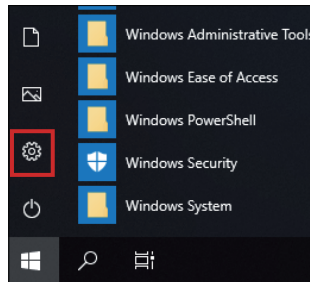

2. In **Apps & features**, select **McAfee Solidifier**.

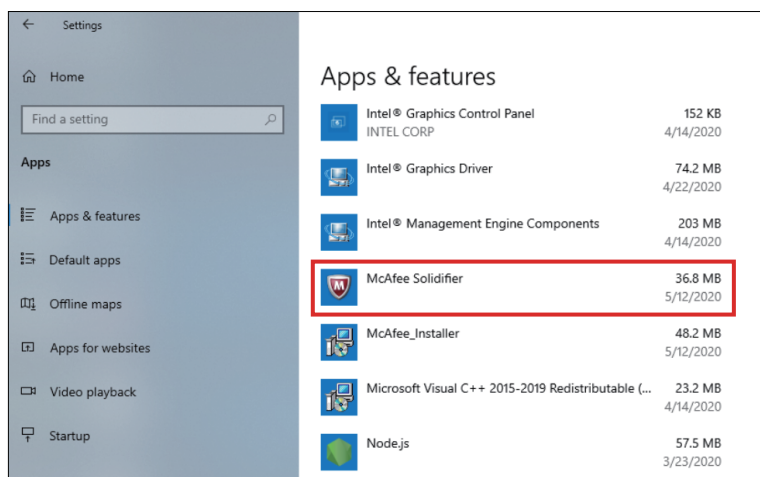

3. Select **Uninstall**.

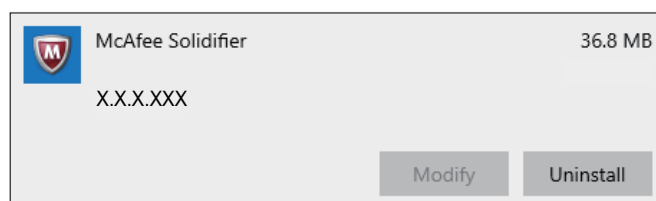

- Follow the same steps and select **McAfee\_Installer**, and then **Uninstall**.

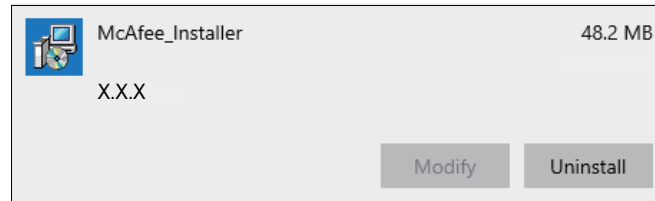

## Backup

After product setup, backing up the system is recommended. Prepare a commercially available USB memory to create a backup USB.

**NOTE:** When HORM is enabled or immediately after hibernation, system backup or recovery will not run properly. Perform system backup or recovery after first disabling HORM and then shutting down the product.

### Creating the backup USB

- Prepare a commercially available USB memory.
- Set up the USB with the Restore and Back-up Tool. Download RecoveryUSB\_Ver\*\* from our website and follow the instructions on the website to set up the USB.  
<https://www.pro-face.com/trans/en/manual/1085.html>
- Insert the USB memory set up with the Restore and Back-up Tool into the product.
- Turn on the product.
- While the boot screen is displayed, press the [F7] key.
- Enter the password (default password: Pw#12345).
- From the following screen, select the USB memory.

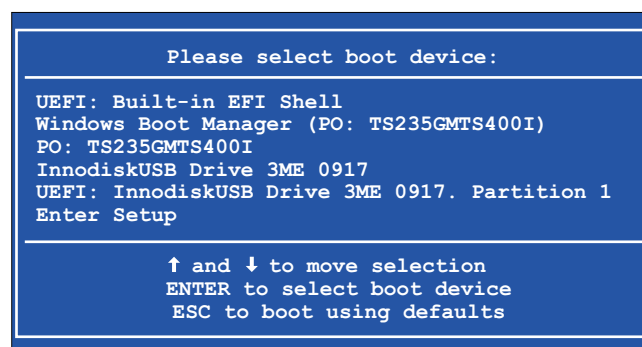

- Select **Backup > OK**.

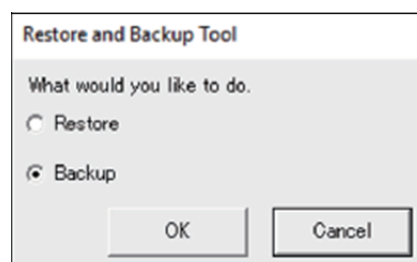

9. Select the disk to backup. Only C drive can be backed up. If there is only one storage, the following screen does not appear and skip to step 10.

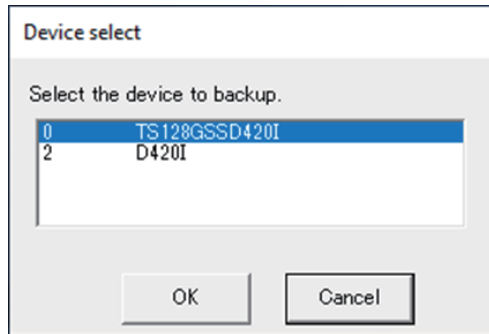

10. Specify the file name and save destination.
11. In the confirmation screen, select OK.

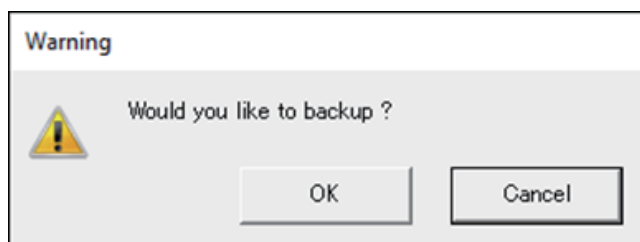

12. Backup begins.

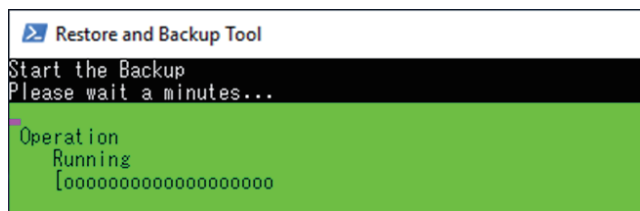

13. After backup is complete, the following screen is displayed. Remove the backup USB from the product, and then select **Restart** or **Shutdown**.

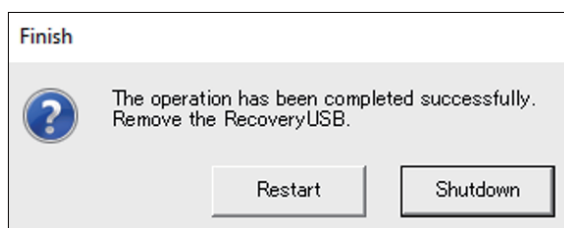

To restore the system, refer to System Recovery, page 179.

## System Recovery

To restore the system, recovery media is required. Purchase the optional Recovery USB (PFXYP6RUSW10) or prepare the USB device used to back up your system.

**NOTE:**

- The optional recovery USB recovers the operating system only. If you require backup in addition to recovery of the operating system, refer to Backup, page 178.
- When HORM is enabled or immediately after hibernation, system backup or recovery will not run properly. Perform system backup or recovery after first disabling HORM and then shutting down the product.

1. Insert the recovery media to this product.
2. Turn on the product.
3. While the boot screen is displayed, press the [F7] key.
4. Enter the password (default password: Pw#12345).
5. Select the recovery media name.

**NOTE:** For the optional recovery USB, the name starts with "UEFI". (The name below is for reference only.)

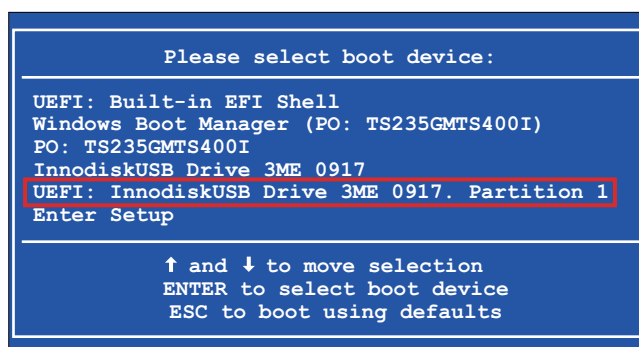

6. If you recover the system with the optional recovery USB, select **OK**. If you recover the system with your backup USB, select **Restore > OK**.

When using the optional recovery USB

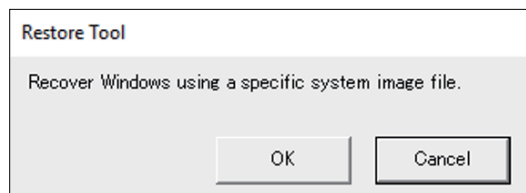

When using your backup USB

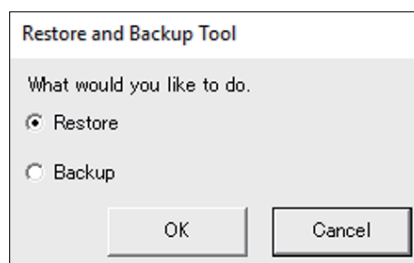

7. Select the disk to recover. If there is only one storage, the following screen does not appear and skip to step 8.

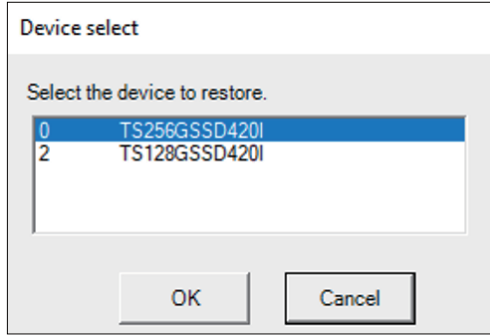

8. In the confirmation screen, select **OK**.



9. Recovery begins.

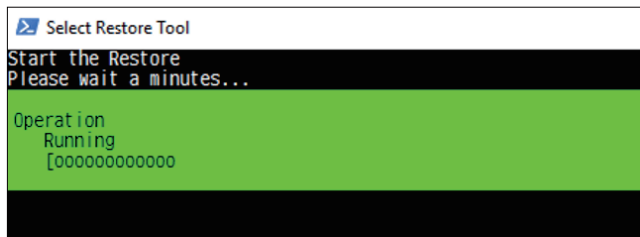

10. After recovery is complete and the following screen is displayed, remove the recovery media from the product and select either **Restart** or **Shutdown**.

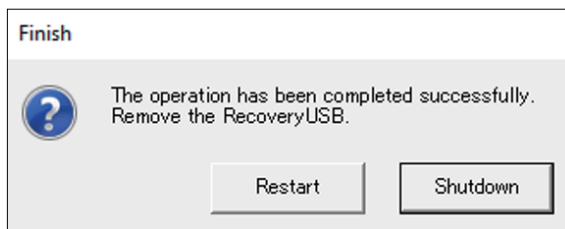

## API

The API is published on our website. Refer to the following URL.

<https://www.pro-face.com/trans/en/manual/1085.html>

API	File
System Monitor API	PFXPHMIP6_SysMonApi_Ver.x.x.zip
DIDO API and Sample Code	PFXPHMIP6_DIDO_SampleCode_Ver.x.x.zip

**NOTE:** For the System Monitor API manual, refer to the following.  
<https://www.pro-face.com/trans/en/product/1086.html>

Schneider Electric Japan Holdings Ltd.  
Schneider Electric Osaka Building, 4-4-9 Kitahama,  
541-0041 Chuo-ku, Osaka  
Japan

+81 (0) 6 6208 3133

[www.pro-face.com](http://www.pro-face.com)

As standards, specifications, and design change from time to time,  
please ask for confirmation of the information given in this publication.

© 2021 – Schneider Electric Japan Holdings Ltd. All rights reserved.

PS6000-MM01-EN\_02