

Q/QnA Series Ethernet Driver

1	System Configuration.....	3
2	Selection of External Device	9
3	Example of Communication Setting.....	10
4	Setup Items.....	60
5	Supported Device.....	69
6	Device Code and Address Code.....	81
7	Error Messages.....	87

Introduction

This manual describes how to connect the display and the External Device (target PLC).

In this manual, the connection procedure will be described by following the below sections:

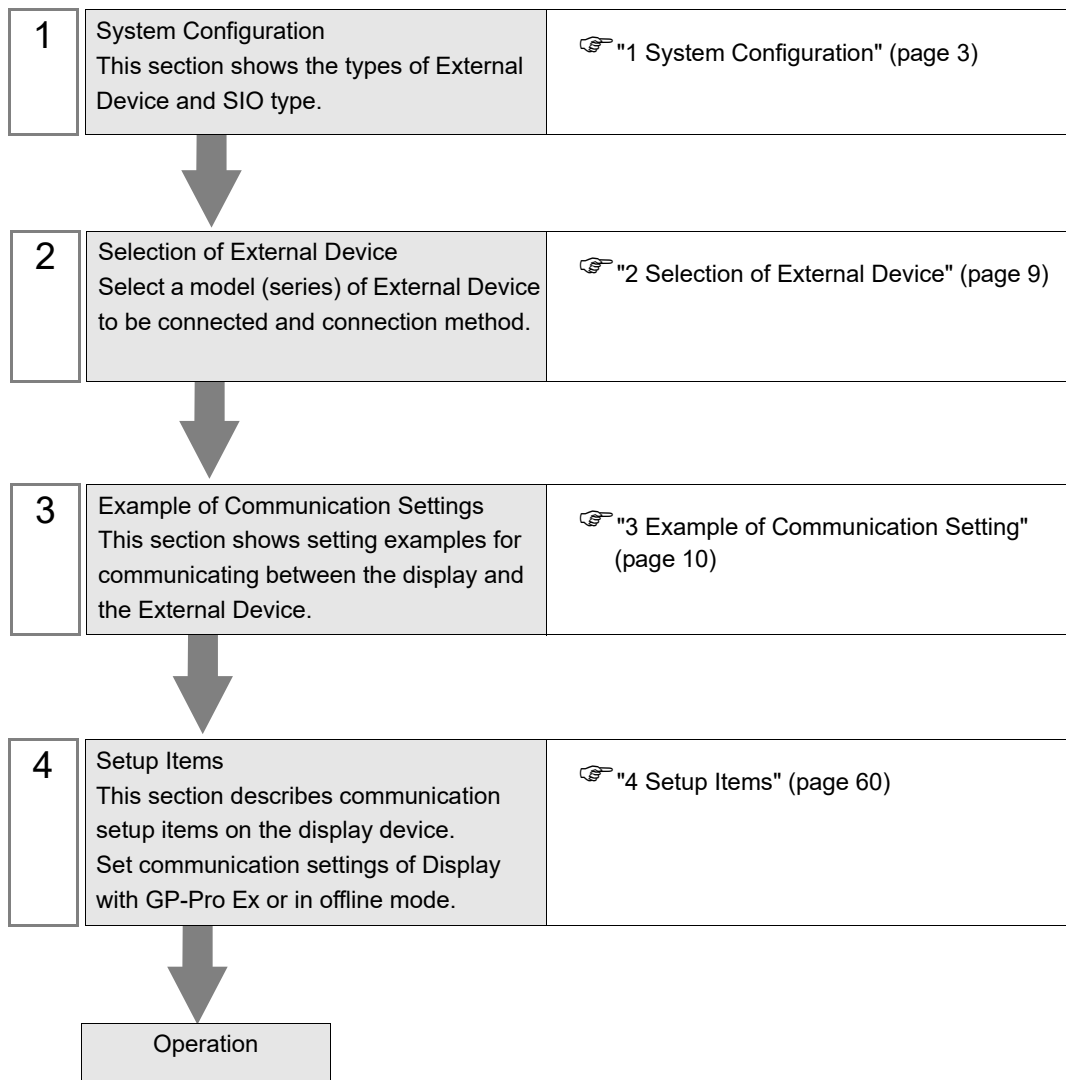

1 System Configuration

The system configuration in the case when the External Device and the Display are connected is shown.

Series	CPU	Link I/F	SIO Type	Setting Example	
MELSEC Q Series	Q00CPU Q00JCPU Q01CPU Q02CPU Q02HCPU Q06HCPU Q12HCPU Q25HCPU	QJ71E71	Ethernet (UDP)	Setting Example 1 (page 10)	
			Ethernet (TCP)	Setting Example 2 (page 15)	
	Q03UDEPCPU Q04UDEHCPU Q06UDEHCPU Q13UDEHCPU Q26UDEHCPU	QJ71E71-B2	Ethernet (UDP)	Setting Example 1 (page 10)	
			Ethernet (TCP)	Setting Example 2 (page 15)	
	Q02UCPU Q03UDCPU Q04UDHCPU Q06UDHCPU Q13UDHCPU Q26UDHCPU	QJ71E71-B5	Ethernet (UDP)	Setting Example 1 (page 10)	
			Ethernet (TCP)	Setting Example 2 (page 15)	
	Q03UDVPCPU Q04UDVPCPU Q06UDVPCPU Q13UDVPCPU Q26UDVPCPU	QJ71E71-100	Ethernet (UDP)	Setting Example 1 (page 10)	
			Ethernet (TCP)	Setting Example 2 (page 15)	
			Ethernet (UDP)	Setting Example 3 (page 20)	
			Ethernet (TCP)	Setting Example 4 (page 24)	
	MELSEC QnA Series	Q2ACPU Q2ACPU-S1 Q3ACPU Q4ACPU Q4ARCPU	AJ71QE71	Ethernet (UDP)	Setting Example 3 (page 20)
				Ethernet (TCP)	Setting Example 4 (page 24)
AJ71QE71-B5			Ethernet (UDP)	Setting Example 3 (page 20)	
			Ethernet (TCP)	Setting Example 4 (page 24)	
Q2ASCPU Q2ASHCPU Q2ASCPU-S1 Q2ASHCPU-S1		A1SJ71QE71-B2	Ethernet (UDP)	Setting Example 3 (page 20)	
			Ethernet (TCP)	Setting Example 4 (page 24)	
		A1SJ71QE71-B5	Ethernet (UDP)	Setting Example 3 (page 20)	
			Ethernet (TCP)	Setting Example 4 (page 24)	

Series	CPU	Link I/F	SIO Type	Setting Example
MELSEC L Series	L02CPU L26CPU-BT	Ethernet port on CPU unit	Ethernet (UDP)	Setting Example 5 (page 28)
			Ethernet (TCP)	Setting Example 6 (page 32)
MELSEC iQ-R Series	R00CPU R01CPU R02CPU R04CPU R08CPU R16CPU R32CPU R120CPU R04ENCPU R08ENCPU R16ENCPU R32ENCPU R120ENCPU R08PCPU R16PCPU R32PCPU R120PCPU R08SFCPU R16SFCPU R32SFCPU R120SFCPU R08PSFCPU R16PSFCPU R32PSFCPU R120PSFCPU	Ethernet port on CPU	Ethernet (UDP)	Setting Example 7 (page 36)
			Ethernet (TCP)	Setting Example 8 (page 40)
		RJ71EN71	Ethernet (UDP)	Setting Example 9 (page 44)
			Ethernet (TCP)	Setting Example 10 (page 48)
MELSEC iQ-F Series	FX5UCPU FX5UCCPU FX5UJCPU	Ethernet port on CPU	Ethernet (UDP)	Setting Example 11 (page 52)
			Ethernet (TCP)	Setting Example 12 (page 56)

IMPORTANT

- When you open the project file (which has been created with the Ver.1.12.04 or earlier Q/QnA series Ethernet driver) with GP-Pro EX where Ver.1.12.05 or later driver is installed, the [Multiple CPU system] checkbox in the [Basic] tab is checked. Specify [Multiple CPU system] according to the environment you use.
☞ " ■ Device Setting" (page 61)
- You can confirm the driver version using GP-Pro EX as follows:
From [System Setting window] in the workspace, select [Peripheral List] to display the version.

NOTE

- The time of GP4000 series can be automatically updated in [Clock Update Settings] of GP-Pro EX, if you set the External Device bit address SM213 to ON.
For details on [Clock Update Settings], refer to GP-Pro EX Reference Manual.

■ Connection Configuration

- 1:1 Connection

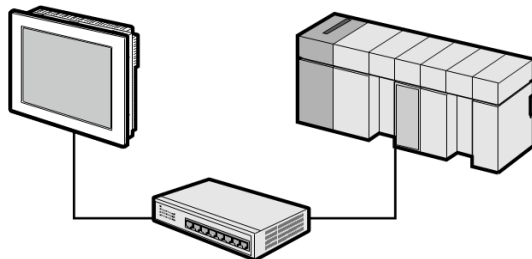

- 1:n Connection (when access station is source station)

Max. 16 units (TCP/IP connection)

Max. 32 units (UDP/IP connection)

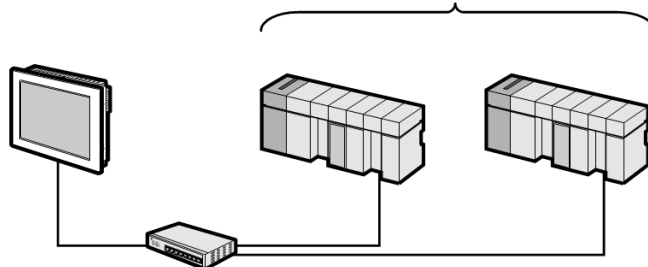

- 1:n Connection (when communicating via network)

You can access other stations via MELSECNET/H, MELSECNET/10, Ethernet, or Q Series C24 unit.

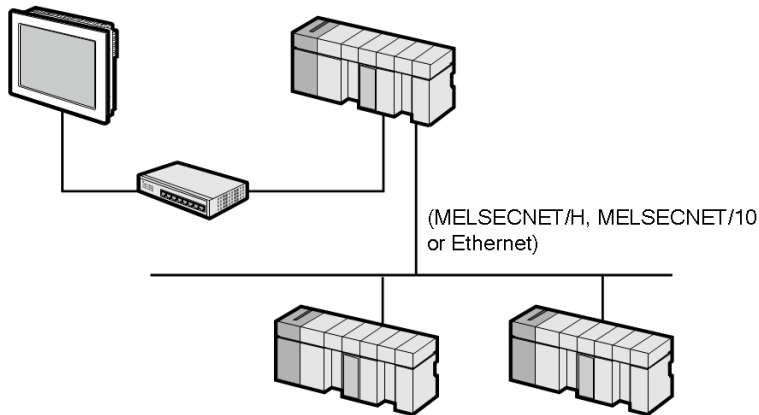
NOTE

- In case of communication via network, please set larger value than the response monitoring time of the relay station for timeout settings.
- When the relay station is iQ-R series, use units with firmware version 9 or later.
- The iQ-F series cannot be used as a relay station.
- Available devices and address ranges for an External Device that uses the network to communicate are limited to the devices and address ranges of the relay station.
- When using the Ethernet interface module QJ71E71-100 on the connected station to access another station through the C24 unit, make sure that the top five digits of the Ethernet interface unit's serial number is 24032 or greater.
Additionally, when accessing other stations through the C24 unit, the routing setting is required for the CPU unit of the relay station.
For information on how to set up routing, refer to the External Device manual.

The following is an example setup on a network. Check the details of the setup items in "Setup Item"

☞ "3.7 Setting Example 7" (page 31)

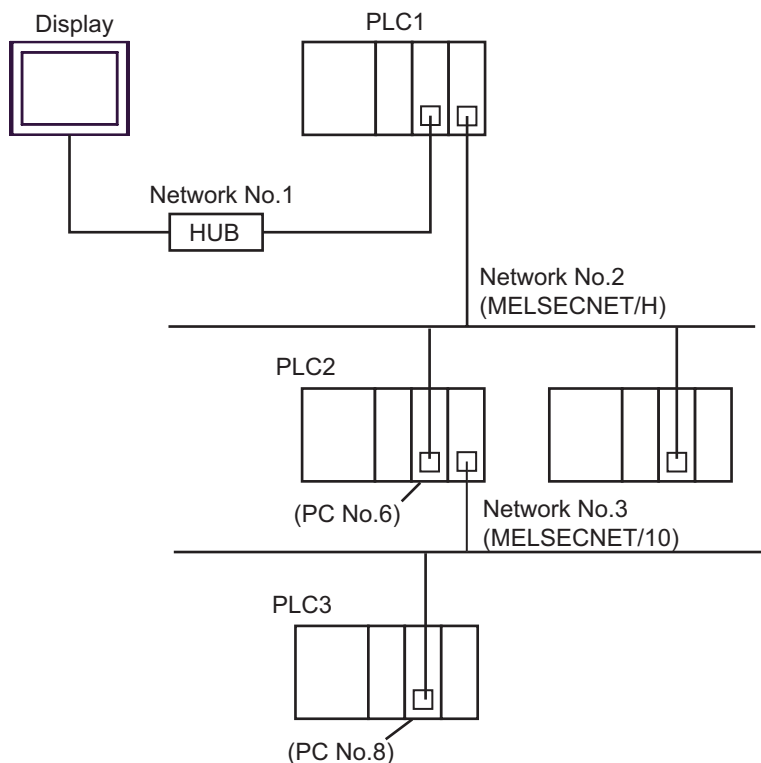

Communication settings

	IP Address	Port No.
Display	192.168.1.1	1025

[Individual Device Settings] dialog box

External Device to be Accessed	IP Address *1	Port No. *2	Network No.	PC No.	Request destination module I/O No.	Request destination module Station No.
PLC1	192.168.1.2	1025	0	255	1023	0
PLC2	192.168.1.2	1026	2	6	1023	0
PLC3	192.168.1.2	1027	3	8	1023	0

*1 Set the IP address of the relay station (PLC1).

*2 The defined port number must be opened on the relay station (PLC1).

- n : 1 Connection

MELSEC-Q Series : Max. 16 units *1
 MELSEC-QnA Series : Max. 8 units *2
 MELSEC-L Series : Max. 16 units
 MELSEC iQ-R Series : Max. 16 units
 MELSEC iQ-F Series : Max. 8 units

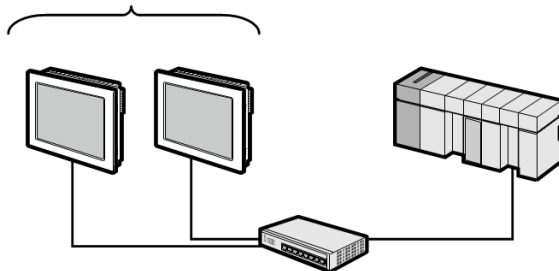

- *1 When transmitting data via the External Device's OPEN Setting feature instead of the Auto OPEN UDP Port feature, up to 16 Displays can be connected. Also, when using the External Device's Auto Open UDP Port feature, there is no limitation for the number of Display units that can be connected.
- *2 When transmitting data via the External Device's parameter setting instead of the Auto OPEN UDP Port feature, up to 8 Displays can be connected. Also, when using the External Device's Auto Open UDP Port feature, there is no limitation for the number of Displays that can be connected.

- Multi CPU System

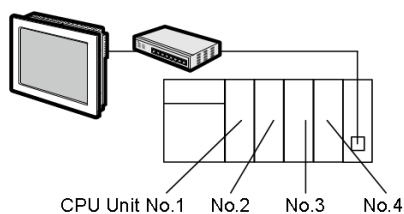
NOTE

- For CPU's Unit No., No.1 is allocated to the CPU slot and No.2, 3, and 4 are allocated to the other slots from No.1 to right.
- With Multi CPU System, it's possible to access a CPU unit that is not directly connected.

2 Selection of External Device

Select the External Device to be connected to the display.

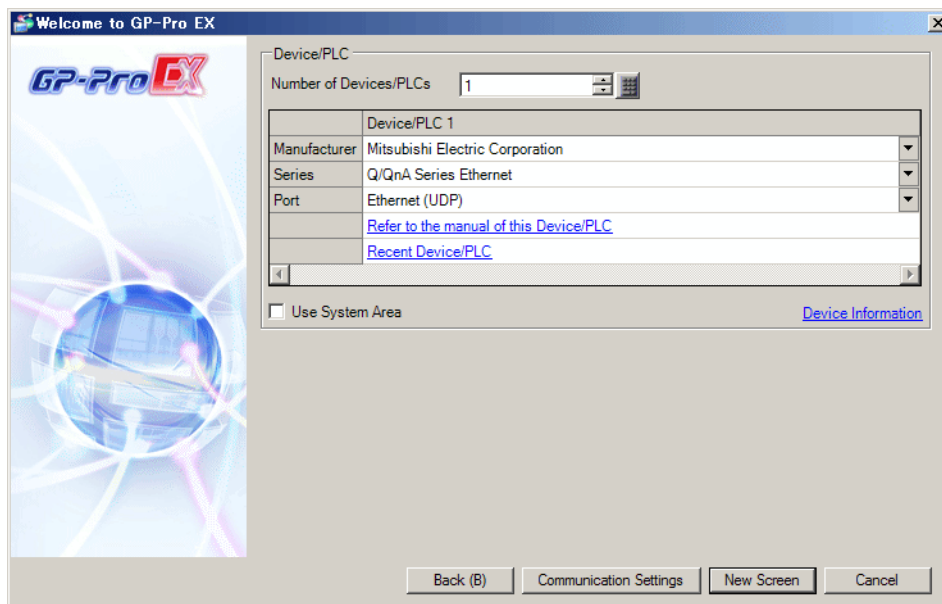

Setup Items	Setup Description
Number of Devices/ PLCs	Enter an integer from 1 to 4 for the number of series to set.
Manufacturer	Select the manufacturer of the External Device to be connected. Select "Mitsubishi Electric Corporation".
Series	Select a model (series) of the External Device to be connected and connection method. Select "Q/QnA Series Ethernet". Check the External Device which can be connected in "Q/QnA Series Ethernet" in system configuration. ☞ "1 System Configuration" (page 3)
Port	Select the port of the display to be connected to the External Device from "Ethernet (UDP)" and "Ethernet (TCP)". NOTE When using PLC ladder monitor, select "Ethernet (UDP)."
Use System Area	Check this option when you synchronize the system data area of Display and the device (memory) of External Device. When synchronized, you can use the ladder program of External Device to switch the display or display the window on the display. Cf. GP-Pro EX Reference Manual "LS Area (Direct Access Method Area)" This can also be set in GP-Pro EX or in the Display's offline mode. Cf. GP-Pro EX Reference Manual "Display Unit (System Area) Settings Guide" Cf. Maintenance/Troubleshooting Guide "Main Unit - System Area Settings"

3 Example of Communication Setting

Examples of communication settings of the Display and the External Device, recommended by Pro-face, are shown.

3.1 Setting Example 1

■ Setting of GP-Pro EX

◆ Communication Settings

To display the setup screen, from the [Project] menu, point to [System Settings] and select [Device/PLC].

Device/PLC 1

Summary [Change Device/PLC](#)

Manufacturer Series Port

Text Data Mode [Change](#)

Communication Settings

Port No.

Timeout (sec)

Retry

Wait To Send (ms)

Device-Specific Settings

Allowable Number of Devices/PLCs 32 [Add Device](#)

No.	Device Name	Settings	Add Indirect Device
1	<input type="text" value="PLC1"/>	<input type="text" value="Series=Q/QnA Series,IP Address=192.168.000.001,Pc"/>	<input type="button" value="Add Indirect Device"/>

◆ Device Setting

To display the [Individual Device Settings] dialog box, from [Device-Specific Settings] in the [Device/PLC] window, select the external device and click [Settings] .

To connect multiple External Devices, from [Device-Specific Settings] in the [Device/PLC] window, click [Add Device] to add another External Device.

[Basic] tab

Individual Device Settings

PLC1

Basic Other Station Access Ladder Monitor

Series Q/QnA Series

IP Address 192.168.0.1

Port No. 1025

Communication data code Binary

Multiple CPU system

No. of CPU 1

Connected to Q Series E71 I/F Module

Bit set in word address operation

Other bits in this word Clear Do not clear

Note on when selecting "Do not clear" : If the ladder program writes data to the word address during the read/write process, the resulting data may be incorrect.

Default

OK (O) Cancel

[Other Station Access] tab

Individual Device Settings

PLC1

Basic Other Station Access Ladder Monitor

Network No. 0

PC No. 255

Request destination module

I/O No. 1023

Station No. 0

Default

OK (O) Cancel

[Ladder Monitor] tab

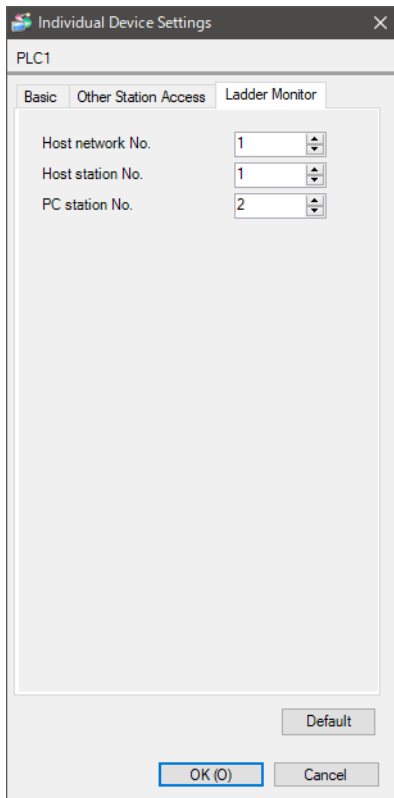

◆ Notes

- Check with a network administrator about IP address. Do not set the duplicate IP address.
- Set IP address on the External Device for IP address in Device-specific settings.
- You need to set IP address on the display in the offline mode of the display.
- Limitations when you use UDP/IP to access the multiple PLCs via network are shown below.
 - When you set the retry frequency to zero, the error message of "Response timed out for initial communication command" is displayed at startup.
 - At startup, you cannot read the device data until timeout time elapses once.

■ Setting of External Device

Perform the settings of External Device in "Network Parameter" of the Parameter Settings of the ladder software.

◆ Network Parameter MNET/10H Ethernet Settings

Setup Items	Settings
Network Type	Ethernet
Head I/O No.	Option
Network No.	Option
Group No.	Option
Station No.	Option
Mode	On-line

◆ Ethernet Operation Settings

Setup Items	Settings
Communication Data Code Settings	Binary
Initial Timing Settings	Always wait for OPEN
IP Address Setting	192.168.0.1
Send Frame Settings	Ethernet (V2.0)
TCP Living Confirmation Settings	Option
Enable Write during RUN	Enable

◆ Open Settings

Setup Items	Settings
Protocol	UDP
Open Method	Unused
Source Port No.	401H ^{*1*2}
Destination IP Address	192.168.0.2 ^{*1*3}
Destination Port Number	401H ^{*1*2*3}
Fixed Buffer	Option
Update Procedure of Fixed Buffer	Procedure exist
Pairing Opening	Option
Living Confirmation	Option

*1 Check with a network administrator about setting value.

*2 Enter in hex number.

*3 Adjust to the setting on Display.

◆ Other Settings

The following settings are items only if necessary.

- **Initial Settings**
Settings related to timer for TCP connection. Basically, communication is available with default settings.
Change the settings when you want to customize (such as shortening timeout).
- **Routing Information**
Set only when you use subnet mask or router.
- **Auto Open UDP Port**
When you use the UDP port, you can communicate using the auto open UDP port (port No. 5000) on the PLC.

◆ Notes

Check with a network administrator about IP address. Do not set the duplicate IP address.

3.2 Setting Example 2

■ Setting of GP-Pro EX

◆ Communication Settings

To display the setup screen, from the [Project] menu, point to [System Settings] and select [Device/PLC].

Device/PLC 1 [Change Device/PLC](#)

Summary

Manufacturer Series Port

Text Data Mode [Change](#)

Communication Settings

Port No. Auto

Timeout (sec)

Retry

Wait To Send (ms)

Device-Specific Settings

Allowable Number of Devices/PLCs [Add Device](#)

No.	Device Name	Settings	Add Indirect Device
1	PLC1	Series=Q/QnA Series,IP Address=192.168.000.001,Pc	<input type="button" value="+"/>

◆ Device Setting

To display the [Individual Device Settings] dialog box, from [Device-Specific Settings] in the [Device/PLC] window, select the external device and click [Settings] .

To connect multiple External Devices, from [Device-Specific Settings] in the [Device/PLC] window, click [Add Device] to add another External Device.

[Basic] tab

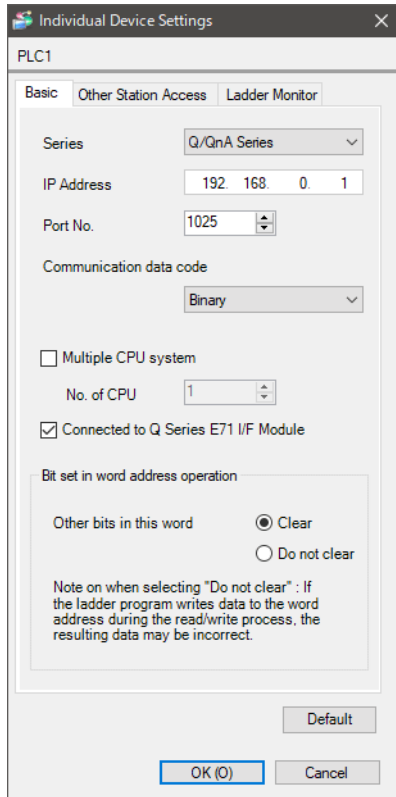

Individual Device Settings

PLC1

Basic Other Station Access Ladder Monitor

Series Q/QnA Series

IP Address 192.168.0.1

Port No. 1025

Communication data code Binary

Multiple CPU system

No. of CPU 1

Connected to Q Series E71 I/F Module

Bit set in word address operation

Other bits in this word Clear Do not clear

Note on when selecting "Do not clear" : If the ladder program writes data to the word address during the read/write process, the resulting data may be incorrect.

Default

OK (O) Cancel

[Other Station Access] tab

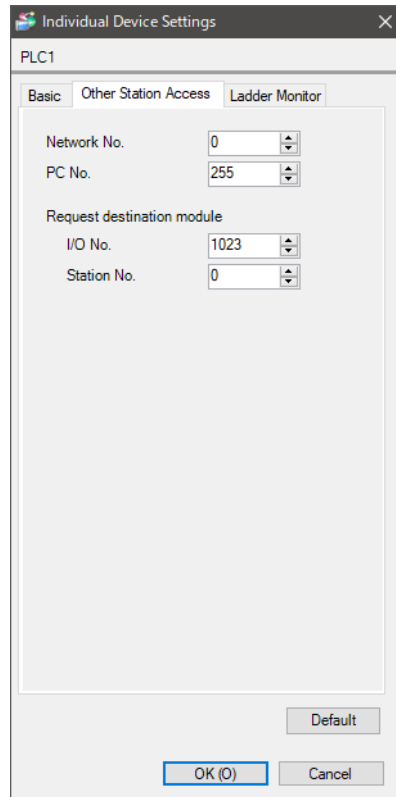

Individual Device Settings

PLC1

Basic Other Station Access Ladder Monitor

Network No. 0

PC No. 255

Request destination module

I/O No. 1023

Station No. 0

Default

OK (O) Cancel

[Ladder Monitor] tab

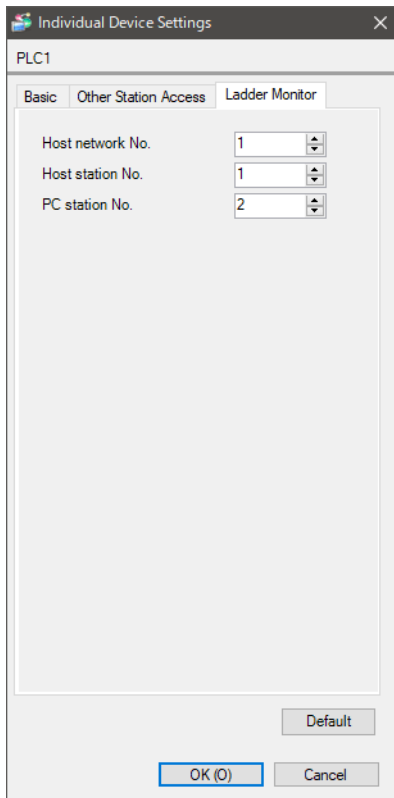

◆ Notes

- Check with a network administrator about IP address. Do not set the duplicate IP address.
- Set IP address on the External Device for IP address in Device-specific settings.
- You need to set IP address on the display in the offline mode of the display.

■ Settings of External Device

Perform the settings of External Device in "Network Parameter" of the Parameter Settings of the ladder software.

◆ Network Parameter MNET/10H Ethernet Settings

Setup Items	Settings
Network Type	Ethernet
Head I/O No.	Option
Network No.	Option
Group No.	Option
Station No.	Option
Mode	On-line

◆ Ethernet Operation Settings

Setup Items	Settings
Communication Data Code Settings	Binary
Initial Timing Settings	Always wait for OPEN
IP Address Setting	192.168.0.1
Send Frame Settings	Ethernet (V2.0)
TCP Living Confirmation Settings	Option
Enable Write during RUN	Enable

◆ Open Settings

Setup Items	Settings
Protocol	TCP
Open Method	Unpassive
Source Port No.	401H ^{*1*2}
Destination IP Address	Setting unnecessary
Destination Port Number	Setting unnecessary
Fixed Buffer	Option
Update Procedure of Fixed Buffer	Procedure exist
Pairing Opening	Option
Living Confirmation	Option

*1 Check with a network administrator about setting value.

*2 Enter in hex number.

◆ Other Settings

The following settings are items only if necessary.

- **Initial Settings**
Settings related to timer for TCP connection. Basically, communication is available with default settings.
Change the settings when you want to customize (such as shortening timeout).
- **Routing Information**
Set only when you use subnet mask or router.
- **Auto Open UDP Port**
When you use the UDP port, you can communicate using the auto open UDP port (port No. 5000) on the PLC.

◆ Notes

Check with a network administrator about IP address. Do not set the duplicate IP address.

3.3 Setting Example 3

■ Setting of GP-Pro EX

To display the setup screen, from the [Project] menu, point to [System Settings] and select [Device/PLC].

Device/PLC 1

Summary [Change Device/PLC](#)

Manufacturer Series Port

Text Data Mode [Change](#)

Communication Settings

Port No.

Timeout (sec)

Retry

Wait To Send (ms)

Device-Specific Settings

Allowable Number of Devices/PLCs [Add Device](#)

No.	Device Name	Settings	Add Indirect Device
<input type="button" value="✂"/>	1	<input type="text" value="PLC1"/> <input type="button" value="⋮"/> <input type="text" value="Series=Q/QnA Series,IP Address=192.168.000.001,Pc"/>	<input type="button" value="⊞"/>

◆ Device Setting

To display the [Individual Device Settings] dialog box, from [Device-Specific Settings] in the [Device/PLC] window, select the external device and click [Settings] .

To connect multiple External Devices, from [Device-Specific Settings] in the [Device/PLC] window, click [Add Device] to add another External Device.

[Basic] tab

Individual Device Settings

PLC1

Basic Other Station Access Ladder Monitor

Series Q/QnA Series

IP Address 192.168.0.1

Port No. 1025

Communication data code Binary

Multiple CPU system

No. of CPU 1

Connected to Q Series E71 I/F Module

Bit set in word address operation

Other bits in this word Clear Do not clear

Note on when selecting "Do not clear" : If the ladder program writes data to the word address during the read/write process, the resulting data may be incorrect.

Default

OK (O) Cancel

[Other Station Access] tab

Individual Device Settings

PLC1

Basic Other Station Access Ladder Monitor

Network No. 0

PC No. 255

Request destination module

I/O No. 1023

Station No. 0

Default

OK (O) Cancel

[Ladder Monitor] tab

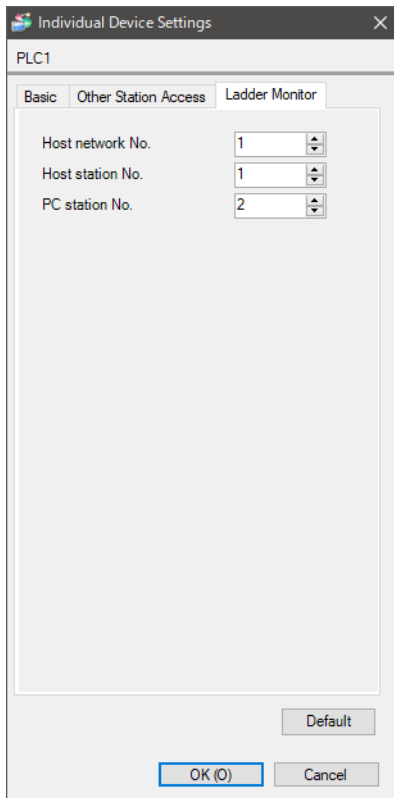

◆ Notes

- Check with a network administrator about IP address. Do not set the duplicate IP address.
- Set IP address on the External Device for IP address in Device-specific settings.
- You need to set IP address on the display in the offline mode of the display.
- Limitations when you use UDP/IP to access the multiple PLCs via network are shown below.
 - When you set the retry frequency to zero, the error message of "Response timed out for initial communication command" is displayed at startup.
 - At startup, you cannot read the device data until timeout time elapses once.

3.4 Setting Example 4

■ Setting of GP-Pro EX

◆ Communication Settings

To display the setup screen, from the [Project] menu, point to [System Settings] and select [Device/PLC].

Device/PLC 1 [Change Device/PLC](#)

Summary

Manufacturer Series Port

Text Data Mode [Change](#)

Communication Settings

Port No. Auto

Timeout (sec)

Retry

Wait To Send (ms)

Device-Specific Settings

Allowable Number of Devices/PLCs 16 [Add Device](#)

No.	Device Name	Settings	Add Indirect Device
1	PLC1	Series=Q/QnA Series,IP Address=192.168.000.001,Pc	<input type="button" value="+"/>

◆ Device Setting

To display the [Individual Device Settings] dialog box, from [Device-Specific Settings] in the [Device/PLC] window, select the external device and click [Settings] .

To connect multiple External Devices, from [Device-Specific Settings] in the [Device/PLC] window, click [Add Device] to add another External Device.

[Basic] tab

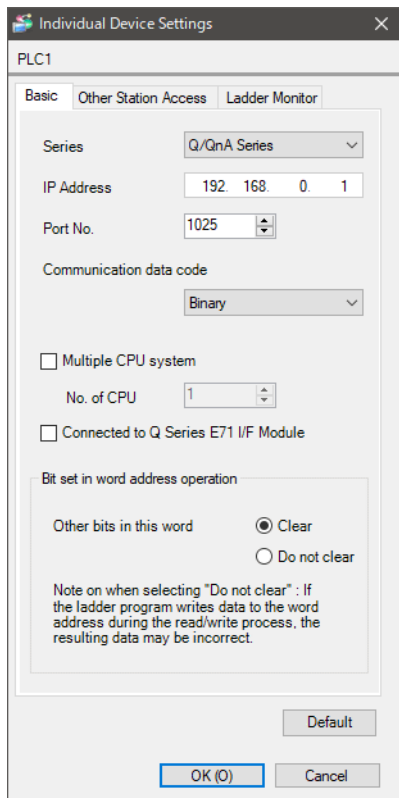

Individual Device Settings

PLC1

Basic Other Station Access Ladder Monitor

Series Q/QnA Series

IP Address 192.168.0.1

Port No. 1025

Communication data code Binary

Multiple CPU system

No. of CPU 1

Connected to Q Series E71 I/F Module

Bit set in word address operation

Other bits in this word Clear Do not clear

Note on when selecting "Do not clear" : If the ladder program writes data to the word address during the read/write process, the resulting data may be incorrect.

Default

OK (O) Cancel

[Other Station Access] tab

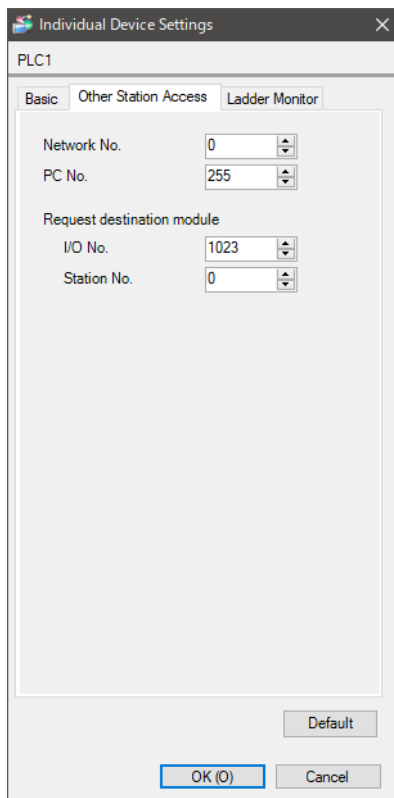

Individual Device Settings

PLC1

Basic Other Station Access Ladder Monitor

Network No. 0

PC No. 255

Request destination module

I/O No. 1023

Station No. 0

Default

OK (O) Cancel

[Ladder Monitor] tab

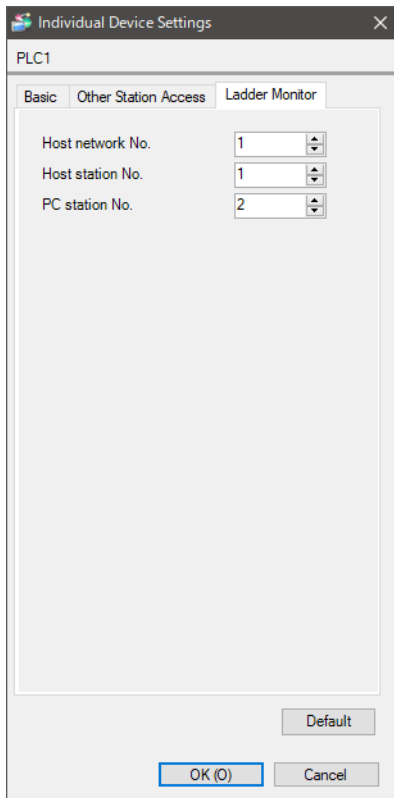

◆ Notes

- Check with a network administrator about IP address. Do not set the duplicate IP address.
- Set IP address on the External Device for IP address in Device-specific settings.
- You need to set IP address on the display in the offline mode of the display.

3.5 Setting Example 5

■ Setting of GP-Pro EX

◆ Communication Settings

To display the setup screen, from the [Project] menu, point to [System Settings] and select [Device/PLC].

Device/PLC 1 [Change Device/PLC](#)

Summary

Manufacturer Series Port

Text Data Mode [Change](#)

Communication Settings

Port No.

Timeout (sec)

Retry

Wait To Send (ms)

Device-Specific Settings

Allowable Number of Devices/PLCs 32 [Add Device](#)

No.	Device Name	Settings	Add Indirect Device
1	<input type="text" value="PLC1"/>	<input type="text" value="Series=Q/QnA Series,IP Address=192.168.000.001,Pa"/>	<input type="button" value="Add Indirect Device"/>

◆ Device Setting

To display the [Individual Device Settings] dialog box, from [Device-Specific Settings] in the [Device/PLC] window, select the external device and click [Settings] .

To connect multiple External Devices, from [Device-Specific Settings] in the [Device/PLC] window, click [Add Device] to add another External Device.

[Basic] tab

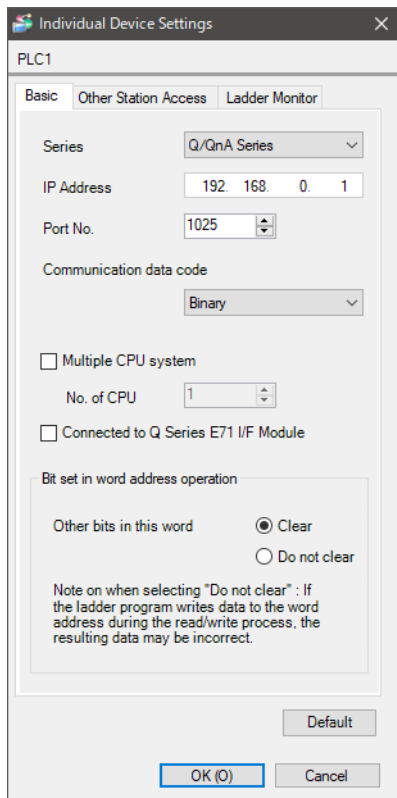

Individual Device Settings

PLC1

Basic Other Station Access Ladder Monitor

Series Q/QnA Series

IP Address 192.168.0.1

Port No. 1025

Communication data code Binary

Multiple CPU system

No. of CPU 1

Connected to Q Series E71 I/F Module

Bit set in word address operation

Other bits in this word Clear Do not clear

Note on when selecting "Do not clear" : If the ladder program writes data to the word address during the read/write process, the resulting data may be incorrect.

Default

OK (O) Cancel

[Other Station Access] tab

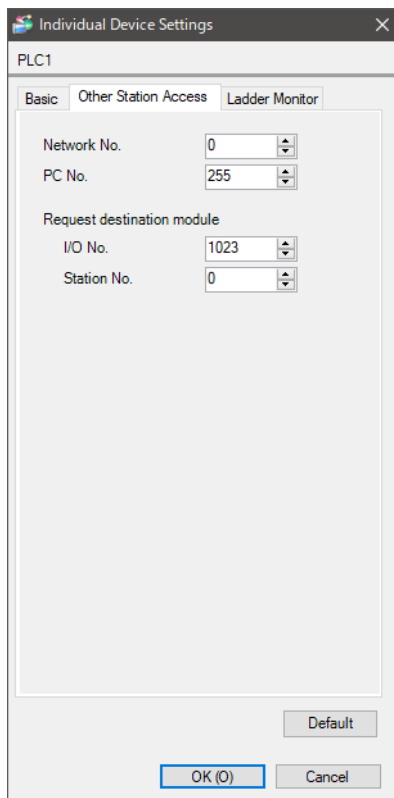

Individual Device Settings

PLC1

Basic Other Station Access Ladder Monitor

Network No. 0

PC No. 255

Request destination module

I/O No. 1023

Station No. 0

Default

OK (O) Cancel

[Ladder Monitor] tab

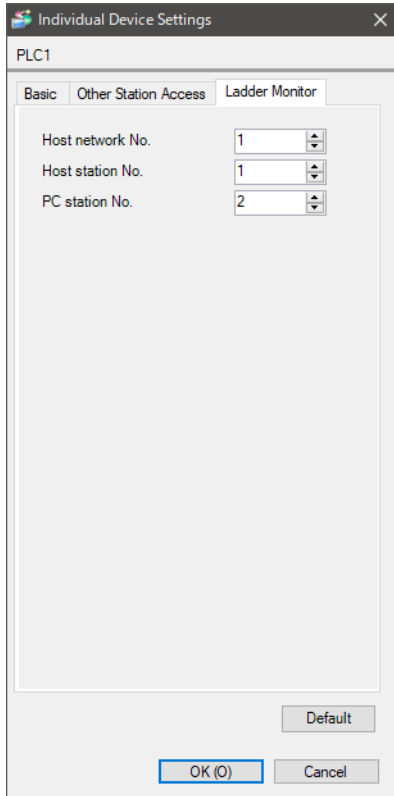

◆ Notes

- The check on [Connected to Q Series E71 I/F Module] is removed.
- Check with a network administrator about IP address. Do not set the duplicate IP address.
- Set IP address on the External Device for IP address in Device-specific settings.
- You need to set IP address on the display in the offline mode of the display.

■ Setting of External Device

To configure communication settings, use the ladder software (GX-Developer Ver.8.88S). After completing the settings, reboot the External Device to enable them. Please refer to the manual of the External Device for details.

- 1 Start up the ladder software.
- 2 Double-click [PC Parameter] under [Parameter].
- 3 Configure the following settings in the [Built-in Ethernet port] tab of the window that appears.

Setup Items	Settings
IP Address	192.168.0.1
Subnet Mask pattern	Option
Default Router IP Address	Option
Communication Data Code Settings	Binary
Enable Write during RUN	Enable ^{*1}

*1 It enables writing to the External Device even when the CPU is in RUN status.

- 4 Click [Open settings].
- 5 Configure the following settings in the window that appears.

Setup Items	Settings
Protocol	UDP
Open Method	MC Protocol
Source Port No.	401H ^{*1}

*1 Use an integer from "0401H to 1387H" and "1392H to FFFE" to enter the source port No. Check with a network administrator about setting value.

NOTE

- When connecting more than one Display, set for the number. Please set the source port No. so as not to overlap.

- 6 Click [End].

3.6 Setting Example 6

■ Setting of GP-Pro EX

◆ Communication Settings

To display the setup screen, from the [Project] menu, point to [System Settings] and select [Device/PLC].

Device/PLC 1

Summary [Change Device/PLC](#)

Manufacturer Series Port

Text Data Mode [Change](#)

Communication Settings

Port No. Auto

Timeout (sec)

Retry

Wait To Send (ms)

Device-Specific Settings

Allowable Number of Devices/PLCs 16 [Add Device](#)

Add Indirect Device

No.	Device Name	Settings
1	PLC1	Series=Q/QnA Series,IP Address=192.168.000.001,Pc

◆ Device Setting

To display the [Individual Device Settings] dialog box, from [Device-Specific Settings] in the [Device/PLC] window, select the external device and click [Settings] .

To connect multiple External Devices, from [Device-Specific Settings] in the [Device/PLC] window, click [Add Device] to add another External Device.

[Basic] tab

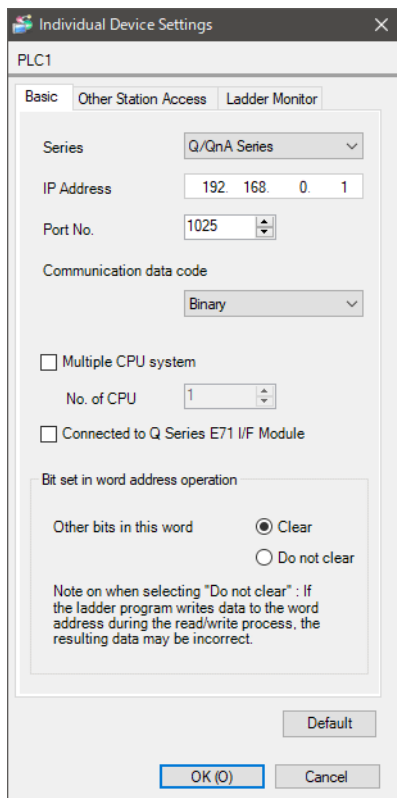

Individual Device Settings

PLC1

Basic Other Station Access Ladder Monitor

Series Q/QnA Series

IP Address 192.168.0.1

Port No. 1025

Communication data code Binary

Multiple CPU system

No. of CPU 1

Connected to Q Series E71 I/F Module

Bit set in word address operation

Other bits in this word Clear Do not clear

Note on when selecting "Do not clear" : If the ladder program writes data to the word address during the read/write process, the resulting data may be incorrect.

Default

OK (O) Cancel

[Other Station Access] tab

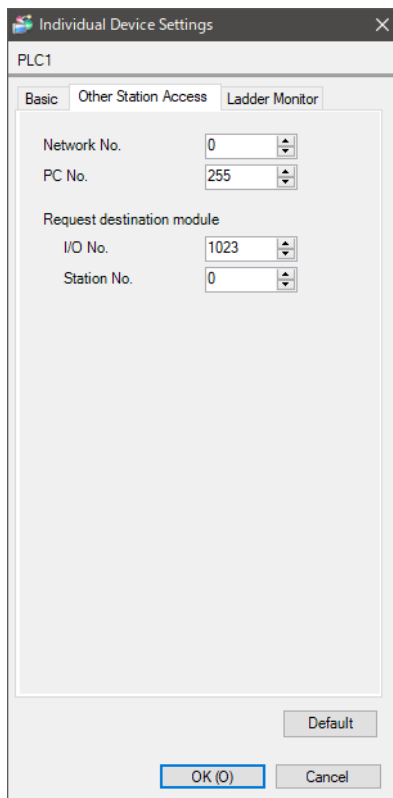

Individual Device Settings

PLC1

Basic Other Station Access Ladder Monitor

Network No. 0

PC No. 255

Request destination module

I/O No. 1023

Station No. 0

Default

OK (O) Cancel

[Ladder Monitor] tab

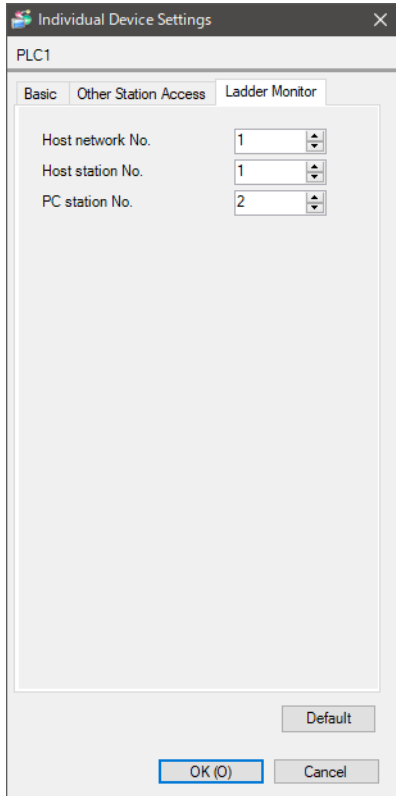

◆ Notes

- The check on [Connected to Q Series E71 I/F Module] is removed.
- Check with a network administrator about IP address. Do not set the duplicate IP address.
- Set IP address on the External Device for IP address in Device-specific settings.
- You need to set IP address on the display in the offline mode of the display.

■ Settings of External Device

To configure communication settings, use the ladder software (GX-Developer Ver.8.88S). After completing the settings, reboot the External Device to enable them. Please refer to the manual of the External Device for details.

- 1 Start up the ladder software.
- 2 Double-click [PC Parameter] under [Parameter].
- 3 Configure the following settings in the [Built-in Ethernet port] tab of the window that appears.

Setup Items	Settings
IP Address	192.168.0.1
Subnet Mask pattern	Option
Default Router IP Address	Option
Communication Data Code Settings	Binary
Enable Write during RUN	Enable ^{*1}

*1 It enables writing to the External Device even when the CPU is in RUN status.

- 4 Click [Open settings].
- 5 Configure the following settings in the window that appears.

Setup Items	Settings
Protocol	TCP
Open Method	MC Protocol
Source Port No.	401H ^{*1}

*1 Use an integer from "0401H to 1387H" and "1392H to FFFE" to enter the source port No. Check with a network administrator about setting value.

NOTE

- When connecting more than one Display, set for the number. Please set the source port No. so as not to overlap.

- 6 Click [End].

3.7 Setting Example 7

■ Setting of GP-Pro EX

◆ Communication Settings

To display the setup screen, from the [Project] menu, point to [System Settings] and select [Device/PLC].

Device/PLC 1 [Change Device/PLC](#)

Summary

Manufacturer Series Port

Text Data Mode [Change](#)

Communication Settings

Port No.

Timeout (sec)

Retry

Wait To Send (ms)

Device-Specific Settings

Allowable Number of Devices/PLCs 32 [Add Device](#)

Add Indirect Device

No.	Device Name	Settings
1	PLC1	Series=Q-R Series,IP Address=192.168.000.001,Port I

◆ Device Setting

To display the [Individual Device Settings] dialog box, from [Device-Specific Settings] in the [Device/PLC] window, select the external device and click [Settings] .

To connect multiple External Devices, from [Device-Specific Settings] in the [Device/PLC] window, click [Add Device] to add another External Device.

[Basic] tab

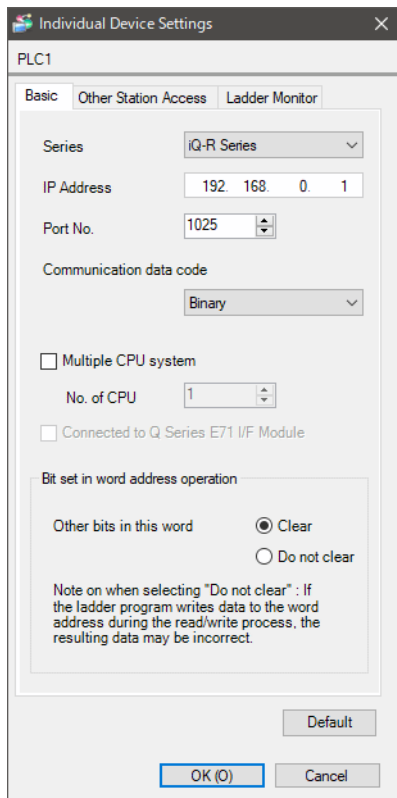

Individual Device Settings

PLC1

Basic Other Station Access Ladder Monitor

Series iQ-R Series

IP Address 192.168.0.1

Port No. 1025

Communication data code Binary

Multiple CPU system

No. of CPU 1

Connected to Q Series E71 I/F Module

Bit set in word address operation

Other bits in this word Clear Do not clear

Note on when selecting "Do not clear" : If the ladder program writes data to the word address during the read/write process, the resulting data may be incorrect.

Default

OK (O) Cancel

[Other Station Access] tab

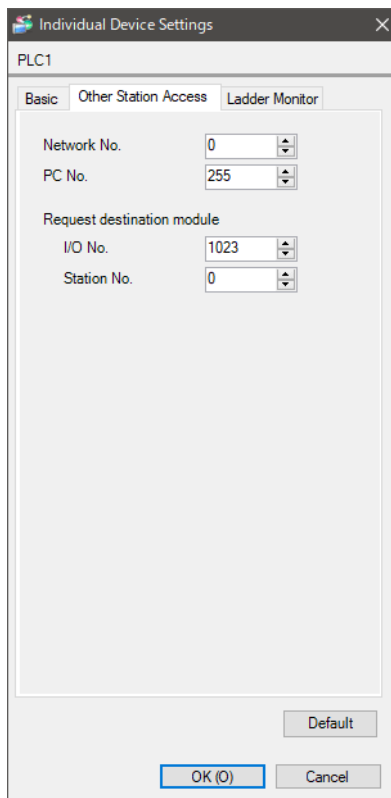

Individual Device Settings

PLC1

Basic Other Station Access Ladder Monitor

Network No. 0

PC No. 255

Request destination module

I/O No. 1023

Station No. 0

Default

OK (O) Cancel

[Ladder Monitor] tab

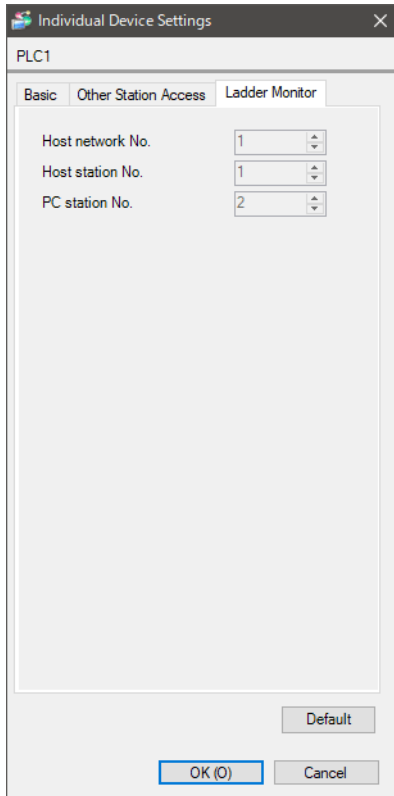
**◆ Notes**

- Check with a network administrator about IP address. Do not set the duplicate IP address.
- Set IP address on the External Device for IP address in Device-specific settings.
- You need to set IP address on the display in the offline mode of the display.

■ Setting of External Device

Use the engineering software MELSOFT GX Works3 to set up communication settings on the External Device.

For details on communication settings, please refer to the manual for the External Device.

- 1 Start the engineering software.
- 2 From the tree view, expand the [Parameter] node and double-click [Module Parameter] for the External Device.
- 3 In the [Module Parameter] window, specify the following parameters.
 - Basic Settings (Own Node Settings)

Setup Items	Setup Description
IP Address	192.168.0.1
Subnet Mask	255.255.255.0
Enable/Disable Online Change	Enable All(SLMP)
Communication Data Code	Binary

- 4 From [External Device Configuration], click [Detailed Setting] and the [Ethernet Configuration] window opens.
- 5 From the [Module List] window's [Ethernet Device (General)] area, select [SLMP Connection Module] and drag-and-drop to the settings screen.
- 6 In the settings screen's [SLMP Connection Module], set up the following.

Setup Items	Setup Description
Protocol	UDP
Port No.	1025

- 7 To save the settings, in the [Module Parameter] window click [Apply].
- 8 The project is saved and sent to the External Device.
Make sure the [Module Parameter] check box is selected.
- 9 Either turn the External Device power OFF/ON, or reset the External Device to verify the changes.

◆ Notes

- Check with a network administrator about IP address. Do not set the duplicate IP address.

3.8 Setting Example 8

■ Setting of GP-Pro EX

◆ Communication Settings

To display the setup screen, from the [Project] menu, point to [System Settings] and select [Device/PLC].

Device/PLC 1 [Change Device/PLC](#)

Summary

Manufacturer Series Port

Text Data Mode [Change](#)

Communication Settings

Port No. Auto

Timeout (sec)

Retry

Wait To Send (ms)

Device-Specific Settings

Allowable Number of Devices/PLCs 16 [Add Device](#)

Add Indirect Device

No.	Device Name	Settings
1	<input type="text" value="PLC1"/>	<input type="text" value="Series=Q-R Series,IP Address=192.168.000.001,Port I"/>

◆ Device Setting

To display the [Individual Device Settings] dialog box, from [Device-Specific Settings] in the [Device/PLC] window, select the external device and click [Settings] .

To connect multiple External Devices, from [Device-Specific Settings] in the [Device/PLC] window, click [Add Device] to add another External Device.

[Basic] tab

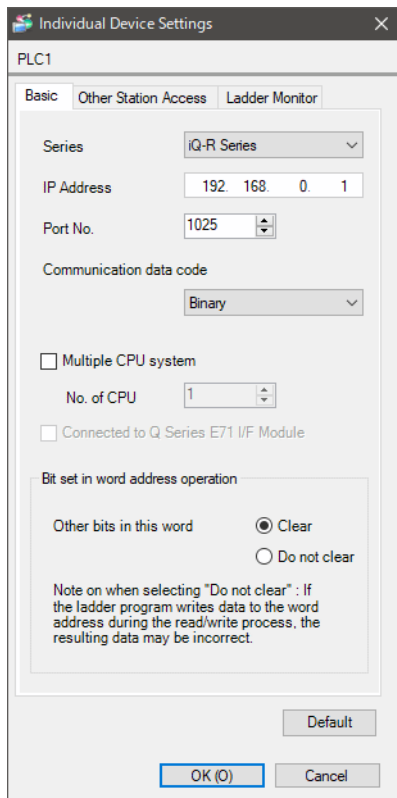

Individual Device Settings

PLC1

Basic Other Station Access Ladder Monitor

Series iQ-R Series

IP Address 192.168.0.1

Port No. 1025

Communication data code Binary

Multiple CPU system

No. of CPU 1

Connected to Q Series E71 I/F Module

Bit set in word address operation

Other bits in this word Clear Do not clear

Note on when selecting "Do not clear" : If the ladder program writes data to the word address during the read/write process, the resulting data may be incorrect.

Default

OK (O) Cancel

[Other Station Access] tab

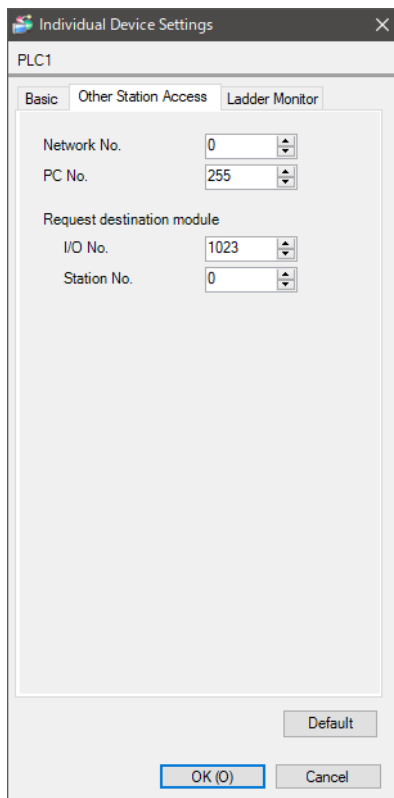

Individual Device Settings

PLC1

Basic Other Station Access Ladder Monitor

Network No. 0

PC No. 255

Request destination module

I/O No. 1023

Station No. 0

Default

OK (O) Cancel

[Ladder Monitor] tab

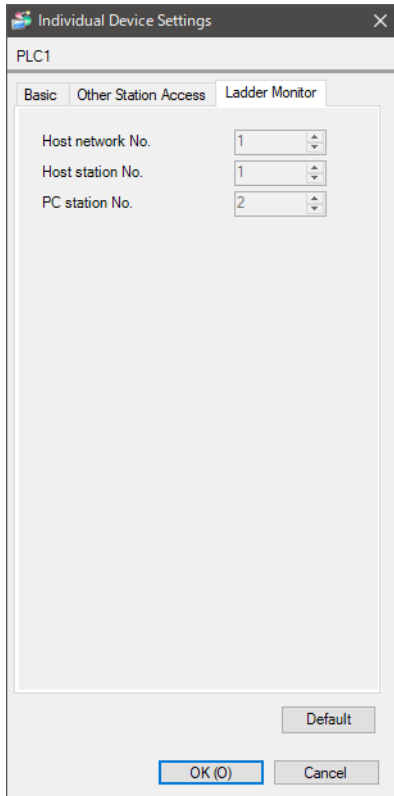

◆ Notes

- Check with a network administrator about IP address. Do not set the duplicate IP address.
- Set IP address on the External Device for IP address in Device-specific settings.
- You need to set IP address on the display in the offline mode of the display.

■ Setting of External Device

Use the engineering software MELSOFT GX Works3 to set up communication settings on the External Device.

For details on communication settings, please refer to the manual for the External Device.

- 1 Start the engineering software.
- 2 From the tree view, expand the [Parameter] node and double-click [Module Parameter] for the External Device.
- 3 In the [Module Parameter] window, specify the following parameters.
 - Basic Settings (Own Node Settings)

Setup Items	Setup Description
IP Address	192.168.0.1
Subnet Mask	255.255.255.0
Enable/Disable Online Change	Enable All(SLMP)
Communication Data Code	Binary

- 4 From [External Device Configuration], click [Detailed Setting] and the [Ethernet Configuration] window opens.
- 5 From the [Module List] window's [Ethernet Device (General)] area, select [SLMP Connection Module] and drag-and-drop to the settings screen.
- 6 In the settings screen's [SLMP Connection Module], set up the following.

Setup Items	Setup Description
Protocol	TCP
Port No.	1025

- 7 To save the settings, in the [Module Parameter] window click [Apply].
- 8 The project is saved and sent to the External Device.
Make sure the [Module Parameter] check box is selected.
- 9 Either turn the External Device power OFF/ON, or reset the External Device to verify the changes.

◆ Notes

- Check with a network administrator about IP address. Do not set the duplicate IP address.

3.9 Setting Example 9

■ Setting of GP-Pro EX

◆ Communication Settings

To display the setup screen, from the [Project] menu, point to [System Settings] and select [Device/PLC].

Device/PLC 1 [Change Device/PLC](#)

Summary

Manufacturer Series Port

Text Data Mode [Change](#)

Communication Settings

Port No.

Timeout (sec)

Retry

Wait To Send (ms)

Device-Specific Settings

Allowable Number of Devices/PLCs 32 [Add Device](#)

Add Indirect Device

No.	Device Name	Settings
1	PLC1	Series=Q-R Series,IP Address=192.168.000.001,Port I

◆ Device Setting

To display the [Individual Device Settings] dialog box, from [Device-Specific Settings] in the [Device/PLC] window, select the external device and click [Settings] .

To connect multiple External Devices, from [Device-Specific Settings] in the [Device/PLC] window, click [Add Device] to add another External Device.

[Basic] tab

Individual Device Settings

PLC1

Basic Other Station Access Ladder Monitor

Series iQ-R Series

IP Address 192.168.0.1

Port No. 1025

Communication data code Binary

Multiple CPU system

No. of CPU 1

Connected to Q Series E71 I/F Module

Bit set in word address operation

Other bits in this word Clear Do not clear

Note on when selecting "Do not clear" : If the ladder program writes data to the word address during the read/write process, the resulting data may be incorrect.

Default

OK (O) Cancel

[Other Station Access] tab

Individual Device Settings

PLC1

Basic Other Station Access Ladder Monitor

Network No. 0

PC No. 255

Request destination module

I/O No. 1023

Station No. 0

Default

OK (O) Cancel

[Ladder Monitor] tab

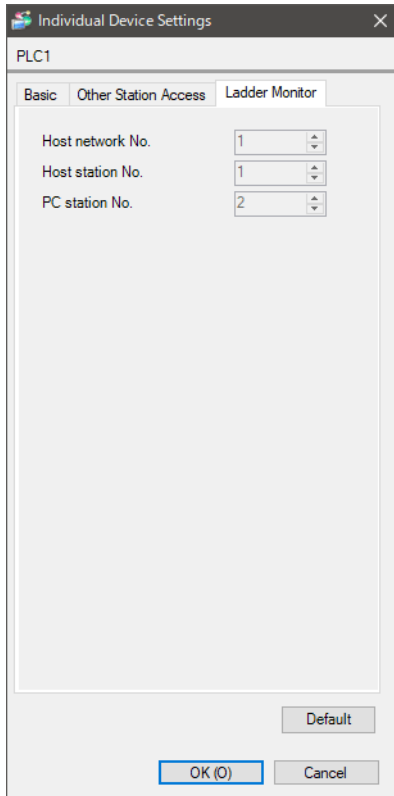

◆ Notes

- Check with a network administrator about IP address. Do not set the duplicate IP address.
- Set IP address on the External Device for IP address in Device-specific settings.
- You need to set IP address on the display in the offline mode of the display.

■ Setting of External Device

Use the engineering software MELSOFT GX Works3 to set up communication settings on the External Device.

For details on communication settings, please refer to the manual for the External Device.

- 1 Start the engineering software.
- 2 From the tree view, click the [Parameter] node, expand [Module Information] and double-click [Module Parameter] for the External Device.
- 3 In the [Module Parameter] window, specify the following parameters.
 - Basic Settings (Own Node Settings)

Setup Items	Setup Description
IP Address	192.168.0.1
Subnet Mask	255.255.255.0
Default Gateway	192.168.0.254
Enable/Disable Online Change	Enable All(SLMP)
Communication Data Code	Binary

- 4 From [External Device Configuration], click [Detailed Setting] and the [Ethernet Configuration] window opens.
- 5 From the [Module List] window's [Ethernet Device (General)] area, select [SLMP Connection Module] and drag-and-drop to the settings screen.
- 6 In the settings screen's [SLMP Connection Module], set up the following.

Setup Items	Setup Description
Protocol	UDP
Port No.	1025

- 7 To save the settings, in the [Module Parameter] window click [Apply].
- 8 The project is saved and sent to the External Device.
Make sure the [Module Parameter] check box is selected.
- 9 Either turn the External Device power OFF/ON, or reset the External Device to verify the changes.

◆ Notes

- Check with a network administrator about IP address. Do not set the duplicate IP address.

3.10 Setting Example 10

■ Setting of GP-Pro EX

◆ Communication Settings

To display the setup screen, from the [Project] menu, point to [System Settings] and select [Device/PLC].

Device/PLC 1 [Change Device/PLC](#)

Summary

Manufacturer Series Port

Text Data Mode [Change](#)

Communication Settings

Port No. Auto

Timeout (sec)

Retry

Wait To Send (ms)

Device-Specific Settings

Allowable Number of Devices/PLCs 16 [Add Device](#)

Add Indirect Device

No.	Device Name	Settings
1	PLC1	Series=Q-R Series,IP Address=192.168.000.001,Port I

◆ Device Setting

To display the [Individual Device Settings] dialog box, from [Device-Specific Settings] in the [Device/PLC] window, select the external device and click [Settings] .

To connect multiple External Devices, from [Device-Specific Settings] in the [Device/PLC] window, click [Add Device] to add another External Device.

[Basic] tab

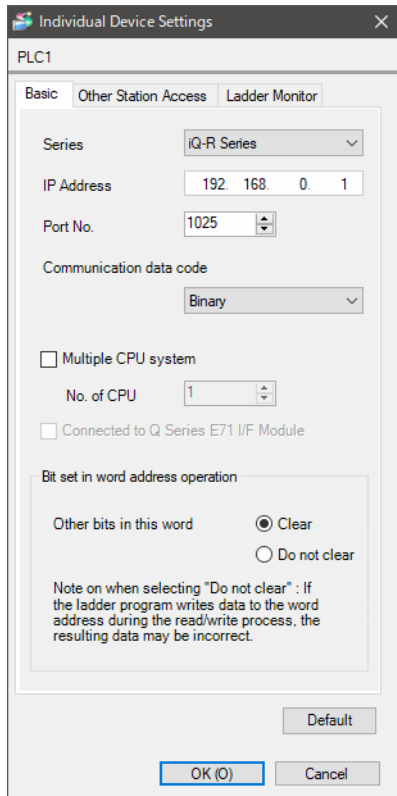

[Other Station Access] tab

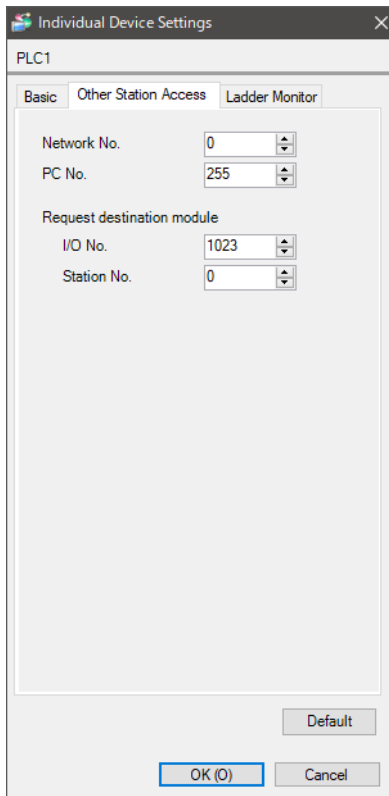

[Ladder Monitor] tab

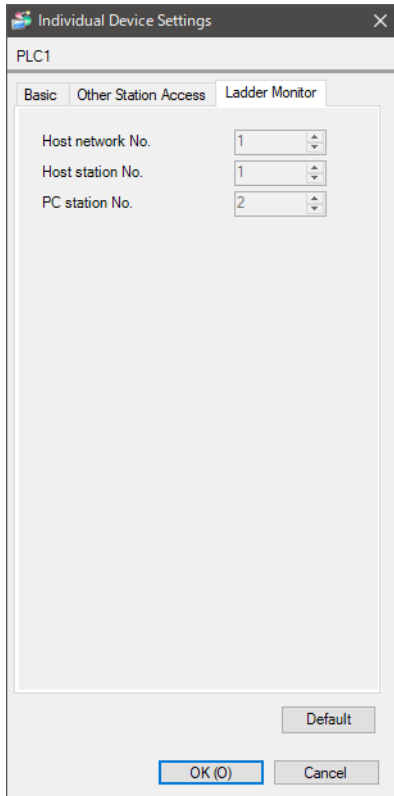

◆ Notes

- Check with a network administrator about IP address. Do not set the duplicate IP address.
- Set IP address on the External Device for IP address in Device-specific settings.
- You need to set IP address on the display in the offline mode of the display.

■ Setting of External Device

Use the engineering software MELSOFT GX Works3 to set up communication settings on the External Device.

For details on communication settings, please refer to the manual for the External Device.

- 1 Start the engineering software.
- 2 From the tree view, click the [Parameter] node, expand [Module Information] and double-click [Module Parameter] for the External Device.
- 3 In the [Module Parameter] window, specify the following parameters.
 - Basic Settings (Own Node Settings)

Setup Items	Setup Description
IP Address	192.168.0.1
Subnet Mask	255.255.255.0
Default Gateway	192.168.0.254
Enable/Disable Online Change	Enable All(SLMP)
Communication Data Code	Binary

- 4 From [External Device Configuration], click [Detailed Setting] and the [Ethernet Configuration] window opens.
- 5 From the [Module List] window's [Ethernet Device (General)] area, select [SLMP Connection Module] and drag-and-drop to the settings screen.
- 6 In the settings screen's [SLMP Connection Module], set up the following.

Setup Items	Setup Description
Protocol	TCP
Port No.	1025

- 7 To save the settings, in the [Module Parameter] window click [Apply].
- 8 The project is saved and sent to the External Device.
Make sure the [Module Parameter] check box is selected.
- 9 Either turn the External Device power OFF/ON, or reset the External Device to verify the changes.

◆ Notes

- Check with a network administrator about IP address. Do not set the duplicate IP address.

3.11 Setting Example 11

■ Setting of GP-Pro EX

◆ Communication Settings

To display the setup screen, from the [Project] menu, point to [System Settings] and select [Device/PLC].

Device/PLC 1 [Change Device/PLC](#)

Summary
 Manufacturer Series Port
 Text Data Mode [Change](#)

Communication Settings
 Port No.
 Timeout (sec)
 Retry
 Wait To Send (ms)

Device-Specific Settings
 Allowable Number of Devices/PLCs 32 [Add Device](#)

No.	Device Name	Settings	Add Indirect Device
1	PLC1	Series=Q-F Series,IP Address=192.168.000.001,Port N	

◆ Device Setting

To display the [Individual Device Settings] dialog box, from [Device-Specific Settings] in the [Device/PLC] window, select the external device and click [Settings] .

To connect multiple External Devices, from [Device-Specific Settings] in the [Device/PLC] window, click [Add Device] to add another External Device.

[Basic] tab

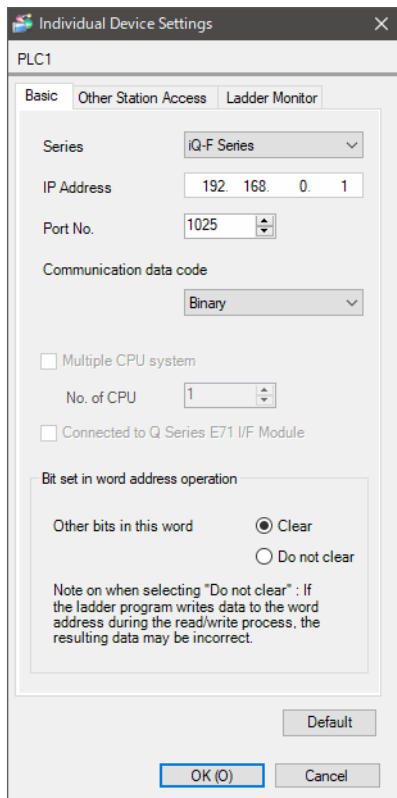

[Other Station Access] tab

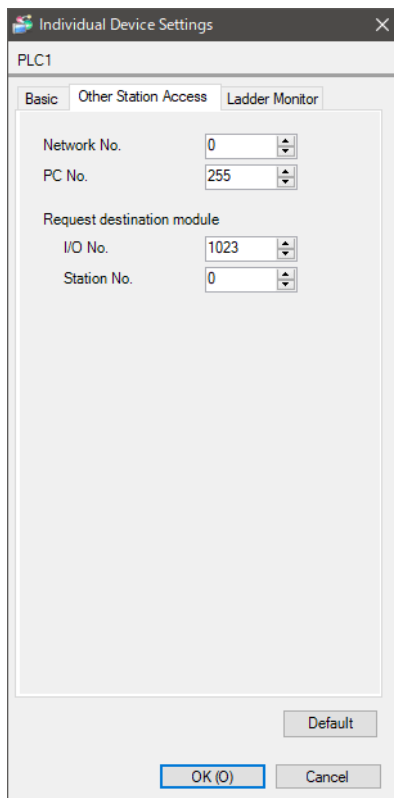

[Ladder Monitor] tab

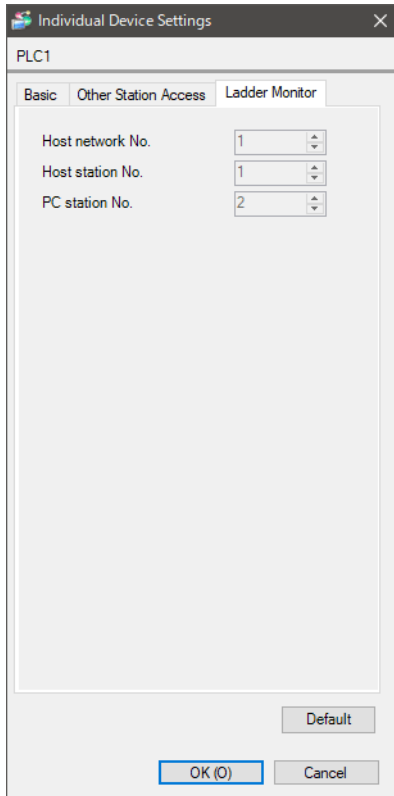

◆ Notes

- Check with a network administrator about IP address. Do not set the duplicate IP address.
- Set IP address on the External Device for IP address in Device-specific settings.
- You need to set IP address on the display in the offline mode of the display.

■ Setting of External Device

Use the engineering software MELSOFT GX Works3 to set up communication settings on the External Device.

For details on communication settings, please refer to the manual for the External Device.

- 1 Start the engineering software.
- 2 From the tree view, click the [Parameter] node, expand [Module Parameter] for the External Device and double-click [Ethernet Port].
- 3 In the [Module Parameter Ethernet Port] window, specify the following parameters.

- Basic Settings (Own Node Settings)

Setup Items	Setup Description
IP Address	192.168.0.1
Subnet Mask	255.255.255.0
Communication Data Code	Binary

- 4 From [External Device Configuration], click [Detailed Setting] and the [Ethernet Configuration] window opens.
- 5 From the [Module List] window's [Ethernet Device (General)] area, select [SLMP Connection Module] and drag-and-drop to the settings screen.
- 6 In the settings screen's [SLMP Connection Module], set up the following.

Setup Items	Setup Description
Protocol	UDP
Port No.	1025

- 7 To save the settings, in the [Module Parameter] window click [Apply].
- 8 The project is saved and sent to the External Device.
Make sure the [Module Parameter] check box is selected.
- 9 Either turn the External Device power OFF/ON, or reset the External Device to verify the changes.

◆ Notes

- Check with a network administrator about IP address. Do not set the duplicate IP address.

3.12 Setting Example 12

■ Setting of GP-Pro EX

◆ Communication Settings

To display the setup screen, from the [Project] menu, point to [System Settings] and select [Device/PLC].

Device/PLC 1 [Change Device/PLC](#)

Summary

Manufacturer Series Port

Text Data Mode [Change](#)

Communication Settings

Port No. Auto

Timeout (sec)

Retry

Wait To Send (ms)

Device-Specific Settings

Allowable Number of Devices/PLCs 16 [Add Device](#)

Add Indirect Device

No.	Device Name	Settings
1	PLC1	Series=Q-F Series,IP Address=192.168.000.001,Port N

◆ Device Setting

To display the [Individual Device Settings] dialog box, from [Device-Specific Settings] in the [Device/PLC] window, select the external device and click [Settings] .

To connect multiple External Devices, from [Device-Specific Settings] in the [Device/PLC] window, click [Add Device] to add another External Device.

[Basic] tab

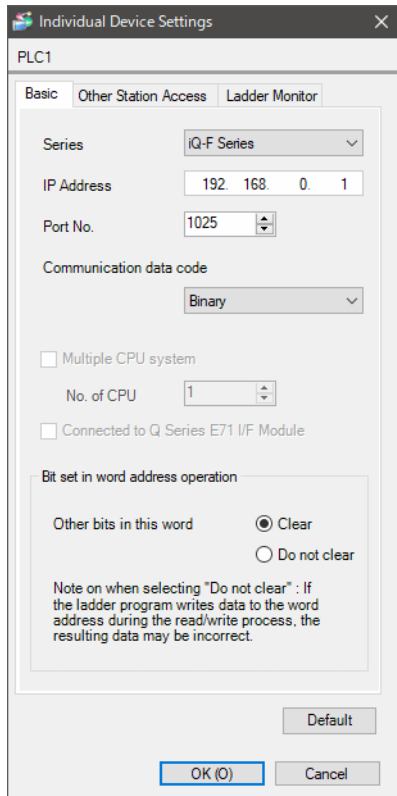

[Other Station Access] tab

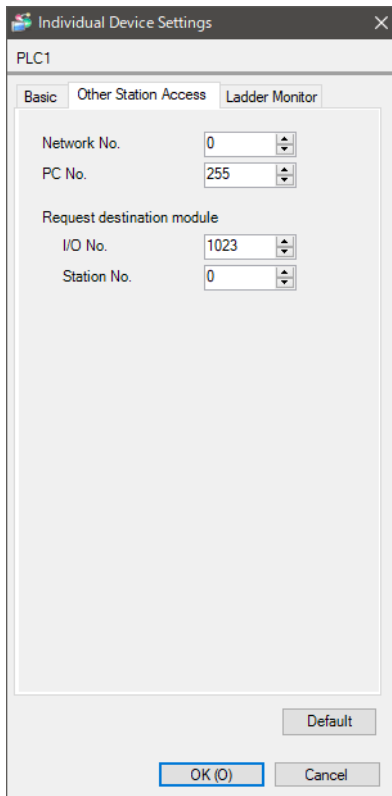

[Ladder Monitor] tab

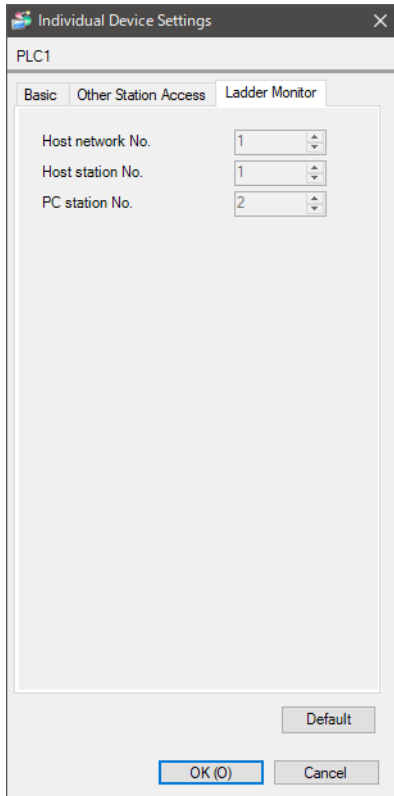

◆ Notes

- Check with a network administrator about IP address. Do not set the duplicate IP address.
- Set IP address on the External Device for IP address in Device-specific settings.
- You need to set IP address on the display in the offline mode of the display.

■ Setting of External Device

Use the engineering software MELSOFT GX Works3 to set up communication settings on the External Device.

For details on communication settings, please refer to the manual for the External Device.

- 1 Start the engineering software.
- 2 From the tree view, click the [Parameter] node, expand [Module Parameter] for the External Device and double-click [Ethernet Port].
- 3 In the [Module Parameter Ethernet Port] window, specify the following parameters.
 - Basic Settings (Own Node Settings)

Setup Items	Setup Description
IP Address	192.168.0.1
Subnet Mask	255.255.255.0
Communication Data Code	Binary

- 4 From [External Device Configuration], click [Detailed Setting] and the [Ethernet Configuration] window opens.
- 5 From the [Module List] window's [Ethernet Device (General)] area, select [SLMP Connection Module] and drag-and-drop to the settings screen.
- 6 In the settings screen's [SLMP Connection Module], set up the following.

Setup Items	Setup Description
Protocol	TCP
Port No.	1025

- 7 To save the settings, in the [Module Parameter] window click [Apply].
- 8 The project is saved and sent to the External Device.
Make sure the [Module Parameter] check box is selected.
- 9 Either turn the External Device power OFF/ON, or reset the External Device to verify the changes.

◆ Notes

- Check with a network administrator about IP address. Do not set the duplicate IP address.

4 Setup Items

Set communication settings of the display with GP-Pro Ex or in offline mode of the display.

The setting of each parameter must be identical to that of External Device.

☞ "3 Example of Communication Setting" (page 10)

NOTE

- Set the Display's IP address in offline mode.

Cf. Maintenance/Troubleshooting Guide "Ethernet Settings"

4.1 Setup Items in GP-Pro EX

■ Communication Settings

To display the setup screen, from the [Project] menu, point to [System Settings] and select [Device/PLC].

Device/PLC 1

Summary

Manufacturer: Mitsubishi Electric Corporation Series: Q/QnA Series Ethernet Port: Ethernet (TCP) [Change Device/PLC](#)

Text Data Mode: 2 [Change](#)

Communication Settings

Port No.: 1025 Auto

Timeout: 3 (sec)

Retry: 0

Wait To Send: 0 (ms) [Default](#)

Device-Specific Settings

Allowable Number of Devices/PLCs: 16 [Add Device](#)

No.	Device Name	Settings	Add Indirect Device
1	PLC1	Series=Q/QnA Series,IP Address=192.168.000.001,Pc	

Setup Items	Setup Description
Port No.	Use an integer from 1025 to 65535 to enter the port No. of the display. When you check the option of [Auto], the port No. will be automatically set. NOTE • [Auto] option is available to set only when you select "Ethernet (TCP)" in [Connecting Method].
Timeout	Use an integer from 1 to 127 to enter the time (s) for which Display waits for the response from External Device. NOTE • In case of communicating via network please set larger value than the response monitoring time of the relay station for timeout settings.
Retry	In case of no response from the External Device, use an integer from 0 to 255 to enter how many times the display retransmits the command.
Wait To Send	Use an integer from 0 to 255 to enter standby time (ms) for the display from receiving packets to transmitting next commands.

■ Device Setting

To display the [Individual Device Settings] dialog box, from [Device-Specific Settings] in the [Device/PLC] window, select the external device and click [Settings] .

To connect multiple External Devices, from [Device-Specific Settings] in the [Device/PLC] window, click [Add Device] to add another External Device.

◆ [Basic] tab

Setup Items	Setup Description
Series	Select the series of the External Device.
IP Address	Set IP address of the External Device. NOTE <ul style="list-style-type: none"> Check with a network administrator about IP address. Do not set the duplicate IP address.
Port No.	Use an integer from 1025 to 65535 to enter the port No. (Decimal) of the External Device. IMPORTANT <ul style="list-style-type: none"> Do not use the following port No. because Ethernet unit reserves them in the system. UDP connection: 5001-5002 TCP connection: 5000-5002
Communication data Code	Select the data format from either [Binary] or [ASCII] to communicate with the External Device. Or when iQ-F Series is selected, either [ASCII(X.Y OCT)] or [ASCII(X.Y HEX)].
Multiple CPU system	Check this option when you use Multiple CPU system.

Setup Items	Setup Description
No. of CPU	Use an integer from 1 to 4 to enter the number of CPU units that is used with Multiple CPU system. NOTE • [No. of CPU] is available to set only when you check [Multiple CPU system].
Connected to Q Series E71 I/F Module	Check this checkbox only when the Q Series E71 I/F unit is used. If this is checked when the Q Series E71 I/F unit is not used, the error may be displayed on the External Device.
Other bits in this word	Select "Clear" or "Do not clear" for the handling of other bit data in the same word when a bit operation is performed to a bit specified word address.

◆ [Other Station Access] tab

The screenshot shows the 'Individual Device Settings' dialog box for 'PLC1'. The 'Other Station Access' tab is selected. The fields are as follows:

- Network No.: 0
- PC No.: 255
- Request destination module:
 - I/O No.: 1023
 - Station No.: 0

Buttons at the bottom include 'Default', 'OK (O)', and 'Cancel'.

Setup Items	Setup Description
Network No.	Set PC No. when you communicate via network. Use an integer from 0 to 239 to enter network No. of the External Device to communicate. If you do not communicate via network, enter 0.
PC No.	Set PC No. when you communicate via network. Use an integer from 0 to 64 or 125 to 126 to enter PC No. of the External Device to communicate. If you do not communicate via network, enter 255.
I/O No.	Set PC No. when you communicate via network. Use an integer from 0 to 511 to enter I/O No. of the External Device to communicate. If you do not communicate via network, enter 1023.
Station No.	Enter a station number of the External Device, using 0 to 31.

◆ [Ladder Monitor] tab

The content of [Ladder Monitor] tab is used on the PLC ladder monitor. If the PLC ladder monitor is not used, the set value becomes invalid. Refer to the Mitsubishi Electric Q Series PLC Ladder Monitor Operation Manual for details of the ladder monitor.

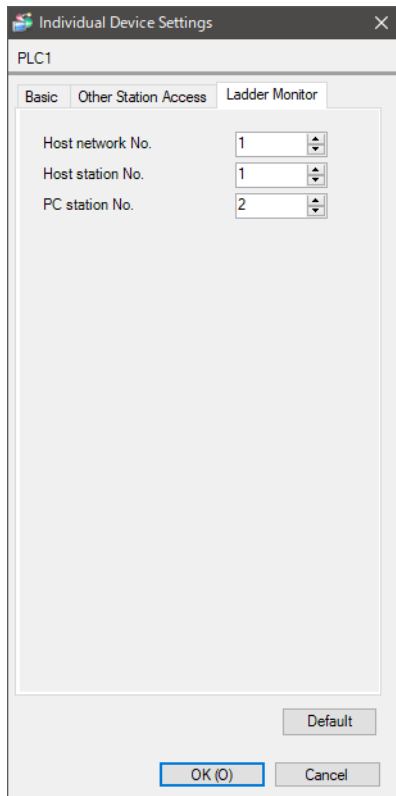

Setup Items	Setup Description
Host network No.	Input the network number that the Display is connected to from 1 through 239.
Host station No.	Input the PC station number of the Display from 1 through 64.
PC station No.	Input the PC station number of the External Device that is directly connected from 1 through 64.

NOTE

- Do not set the same PC station number within the same network.
- If an error is displayed on the PLC ladder monitor, set the same number as the one for [Host network No.] (in the [Ladder Monitor] tab) to [Network No.] (in the [Other Station Access] tab). In addition, set the same number as the one for [PC station No.] (in the [Ladder Monitor] tab) to [PC No.] (in the [Other Station Access] tab).
- The PLC ladder monitor cannot be used for the External Device that is connected via the serial communication module.

- Setting examples of [Ext. Setting] tab are shown below.

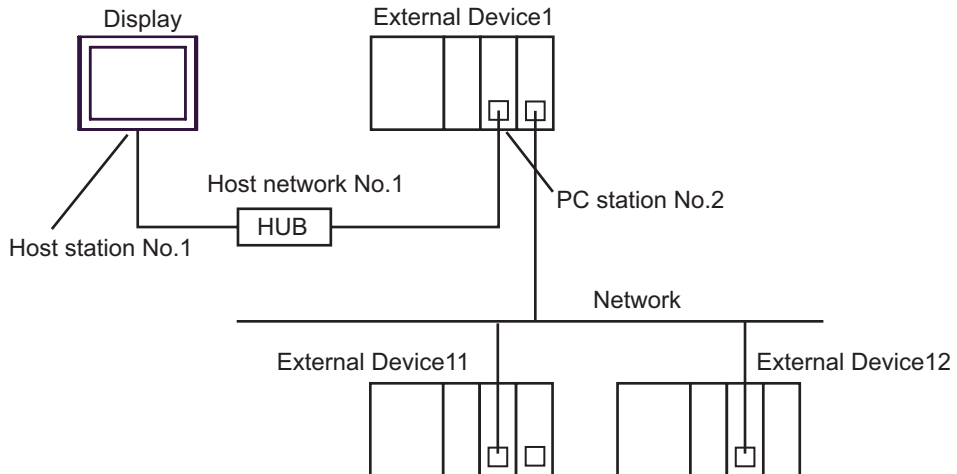

Setup Items	Settings
Host network No.	1
Host station No.	1
PC station No.	2

4.2 Setup Items in Offline Mode

NOTE

- Refer to the Maintenance/Troubleshooting guide for information on how to enter offline mode or about the operation.

Cf. Maintenance/Troubleshooting Guide "Offline Mode"

■ Communication Settings

To display the setting screen, touch [Device/PLC Settings] from [Peripheral Settings] in offline mode. Touch the External Device you want to set from the displayed list.

Comm.	Device			
Q/QnA Series Ethernet [UDP] Page 1/1				
Port No.	<input checked="" type="radio"/> Fixed <input type="radio"/> Auto	<input type="text" value="1025"/>		
Timeout(s)		<input type="text" value="3"/>		
Retry		<input type="text" value="2"/>		
Wait To Send(ms)		<input type="text" value="0"/>		
Exit		Back		2022/12/02 15:23:03

Setup Items	Setup Description
Port No.	Set the Port No. of the display. In UDP connection, entered port No. will be assigned regardless of whether you select [Fixed] or [Auto]. In TCP connection, select either of [Fixed] or [Auto]. When you select [Fixed], use an integer from 1025 to 65535 to enter the port No. of the display. When you select [Auto], the port No. will be automatically assigned regardless of the entered value.
Timeout	Use an integer from 1 to 127 to enter the time (s) for which Display waits for the response from External Device. NOTE <ul style="list-style-type: none"> In case of communicating via network, please set larger value than the response monitoring time of the relay station for timeout settings.
Retry	In case of no response from the External Device, use an integer from 0 to 255 to enter how many times the display retransmits the command.
Wait To Send	Use an integer from 0 to 255 to enter standby time (ms) for the display from receiving packets to transmitting next commands.

■ Device Setting

To display the setting screen, touch [Device/PLC Settings] from [Peripheral Settings]. Touch the External Device you want to set from the displayed list, and touch [Device].

(Page 1/3)

Comm.	Device			
Q/QnA Series Ethernet		[UDP]	Page 1/3	
Device/PLC Name		[PLC1]		
Series	Q/QnA Series			
IP Address	192 168 0 1			
Port No.	1025			
Data Code	Binary			
Multiple CPU	Not Use			
Q Series E71 I/F	[OFF]			
				➔
Exit		Back		2022/12/02 15:23:46

Setup Items	Setup Description
Device/PLC Name	Select the External Device for device setting. Device name is a title of External Device set with GP-Pro EX.(Initial value [PLC1])
Series	Display the series of the External Device.
IP Address	Set IP address of the External Device. NOTE <ul style="list-style-type: none"> Check with a network administrator about IP address. Do not set the duplicate IP address.
Port No.	Use an integer from 1025 to 65535 to enter the port No. (Decimal) of the External Device. IMPORTANT <ul style="list-style-type: none"> Do not use the following port No. because Ethernet unit reserves them in the system. UDP connection: 5001-5002 TCP connection: 5000-5002
Data Code	Display the data format of External Device communication in either [Binary] or [ASCII] format.
Multiple CPU	The setting of Multiple CPU system is displayed in "NotUse" or "1 to 4".
Q Series E71 I/F	Select "ON" and "OFF" respectively when the Q Series E71 I/F unit is used and when the Q Series E71 I/F unit is not used. If "ON" is selected when the Q Series E71 I/F unit is not used, the error may be displayed on the External Device.

(Page 2/3)

The content of [Ext. Setting] tab is used on the PLC ladder monitor. If the PLC ladder monitor is not used, the set value becomes invalid. Refer to the Mitsubishi Electric Q Series PLC Ladder Monitor Operation Manual for details of the ladder monitor.

Comm.	Device			
Q/QnA Series Ethernet		[UDP]	Page 2/3	
Device/PLC Name <input type="text" value="PLC1"/>				
Network No.		<input type="text" value="0"/>		
PC No.		<input type="text" value="255"/>		
Request destination module				
I/O No.		<input type="text" value="1023"/>		
Station No.		<input type="text" value="0"/>		
Ladder Monitor Setting				
Host network No.		<input type="text" value="1"/>		
Host station No.		<input type="text" value="1"/>		
PC station No.		<input type="text" value="2"/>		
		← →		
Exit		Back		2022/12/02 15:24:11

Setup Items	Setup Description
Device/PLC Name	Select the External Device for device setting. Device name is a title of External Device set with GP-Pro EX.(Initial value [PLC1])
Network No.	Set PC No. when you communicate via network. Use an integer from 0 to 239 to enter network No. of the External Device to communicate. If you do not communicate via network, enter 0.
PC No.	Set PC No. when you communicate via network. Use an integer from 0 to 64 or 125 to 126 to enter PC No. of the External Device to communicate. If you do not communicate via network, enter 255.
I/O No.	Set PC No. when you communicate via network. Use an integer from 0 to 511 to enter I/O No. of the External Device to communicate. If you do not communicate via network, enter 1023.
Station No.	Enter a station number of the External Device, using 0 to 31.
Host network No.	Input the network number that the Display is connected to from 1 through 239.
Host station No.	Input the PC station number of the Display from 1 through 64.
PC station No.	Input the PC station number of the External Device that is directly connected from 1 through 64.

NOTE

- Do not set the same PC station number within the same network.
- Refer to the [Ladder Monitor] tab of "Setup Items in GP-Pro EX" for the examples of [Ladder Monitor] tab.
 " ◆ [Ladder Monitor] tab" (page 63)
- When the External Device is the iQ-R, the ladder monitor settings are ignored.
- When the External Device is the iQ-F, the all settings on this page are ignored.

(Page 3/3)

Comm.	Device			
Q/QnA Series Ethernet		[UDP]	Page 3/3	
Device/PLC Name		[PLC1]		
Bit set in word address operation				
Other bits		Clear		
				←
Exit		Back		2022/12/02 15:24:25

Setup Items	Setup Description
Device/PLC Name	Select the External Device for device setting. Device name is a title of External Device set with GP-Pro EX.(Initial value [PLC1])
Bit set in word address operation	Displays "Clear" or "Do not clear" for the handling of other bit data in the same word when a bit operation is performed to a bit specified word address. (Cannot be set in offline mode.)

5 Supported Device

Range of supported device address is shown in the table below. Please note that the actually supported range of the devices varies depending on the External Device to be used. Please check the actual range in the manual of your External Device.



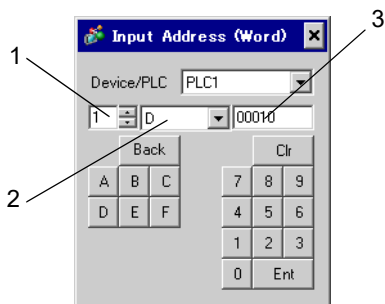















Input address of external device in the dialog below.

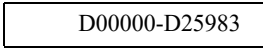

- | | |
|----------------|--|
| 1. Unit Number | Select the number of a CPU unit to communicate with from 1 to 4.
Select "0" to access a CPU unit that is directly connected like the Single CPU System. |
| 2. Device | Specify a device. |
| 3. Address | Specify an address. |

5.1 MELSEC Q (High performance model, Basic model) / MELSEC QnA Series

 This address can be specified as system data area.

Device	Bit Address	Word Address	32 bits	Notes
Input Relay	X0000-X1FFF	X0000-X1FF0	L/H	 *1
Output Relay	Y0000-Y1FFF	Y0000-Y1FF0		 *1
Internal Relay	M00000-M32767	M00000-M32752		 *1
Special Relay	SM0000-SM2047	SM0000-SM2032		 *1
Latch Relay	L00000-L32767	L00000-L32752		 *1
Annunciator	F00000-F32767	F00000-F32752		 *1
Edge Relay	V00000-V32767	V00000-V32752		 *1
Step Relay	S0000-S8191	S0000-S8176		 *1
Link Relay	B0000-B7FFF	B0000-B7FF0		 *1
Special Link Relay	SB000-SB7FF	SB000-SB7F0		 *1
Timer (Contact)	TS00000-TS23087	-----		
Timer (Coil)	TC00000-TC23087	-----		
Retentive Timer (Contact)	SS00000-SS23087	-----		
Retentive Timer (Coil)	SC00000-SC23087	-----		
Counter (Contact)	CS00000-CS23087	-----		
Counter (Coil)	CC00000-CC23087	-----		
Timer (Current Value)	-----	TN00000-TN23087		
Retentive Timer (Current Value)	-----	SN00000-SN23087		
Counter (Current Value)	-----	CN00000-CN23087		
Data Register	-----	 D00000-D25983		 *1
Special Register	-----	SD0000-SD2047		 *1
Link Register	-----	W0000-W657F		 *1
Special Link Register	-----	SW000-SW7FF		 *1
Module Access Device	-----	U000-G00000 - U1FF-G65535		 *1 *2
File Register (Normal)	-----	R00000-R32767		 *1 *3
File Register (Block switching is not necessary)	-----	ZR0000000-ZR1042431		 *1 *3

Device	Bit Address	Word Address	32 bits	Notes
File Register (0R - 31R) ^{*4}	-----	0R0000-0R32767	L/H	Bit F *1 *3
	-----	1R0000-1R32767		
	-----	2R0000-2R32767		
	:	:		
	-----	30R0000-30R32767		
	-----	31R0000-31R26623		

*1 The access method when specifying bits is different depending on the setting of "Other bits in this word" in "Individual Device Settings".

[Clear] **Bit F**

[Do not clear] When bits are written, the Display reads the corresponding word address from the External Device, sets particular bits of that word address to ON, and then returns the resulting address to the External Device. Note that the data may not be written correctly if you write to the word address using the ladder program while the Display is reading data from, and writing data to, the External Device.

*2 Device that is compatible with SLMP or device that can access the buffer memory of Intelligent Function Modules. The first three digits of the address specifies the starting I/O number of the Intelligent Function Module.

*3 It is different by the memory card which uses the range of file register.

*4 Set the block No. on the head of device name. This is the device name for conversion with GP-Pro/PBIII for Windows. When you newly specify the device, we recommend that you should use the file register (Block switching is not necessary).

NOTE

- The notation of addresses differs depending on a selected Unit No.

<Ex.>When 0 is selected for Unit No.,

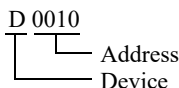



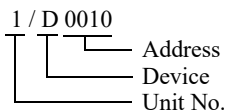







<Ex.>When 1 is selected for Unit No.,











- Please refer to the GP-Pro EX Reference Manual for system data area.
Cf. GP-Pro EX Reference Manual "LS Area (Direct Access Method Area)"
- Please refer to the precautions on manual notation for icons in the table.
☞ "Manual Symbols and Terminology"

5.2 MELSEC Q (Universal model) Series

 This address can be specified as system data area.

Device	First 5 digits of the serial No. in the CPU unit: Less than 10042		First 5 digits of the serial No. in the CPU unit: 10042 or later		32bits	Notes
	Bit Address	Word Address	Bit Address	Word Address		
Input Relay	X0000-X1FFF	X0000-X1FF0	X0000-X1FFF	X0000-X1FF0	L / H	
Output Relay	Y0000-Y1FFF	Y0000-Y1FF0	Y0000-Y1FFF	Y0000-Y1FF0		
Internal Relay	M00000-M32767	M00000-M32752	M00000-M61439	M00000-M61424		
Special Relay	SM0000-SM2047	SM0000-SM2032	SM0000-SM2047	SM0000-SM2032		
Latch Relay	L00000-L32767	L00000-L32752	L00000-L32767	L00000-L32752		
Annunciator	F00000-F32767	F00000-F32752	F00000-F32767	F00000-F32752		
Edge Relay	V00000-V32767	V00000-V32752	V00000-V32767	V00000-V32752		
Step Relay	S0000-S8191	S0000-S8176	S0000-S16383	S0000-S16368		
Link Relay	B0000-B7FFF	B0000-B7FF0	B0000-BEFFF	B0000-BEFFF0		
Special Link Relay	SB0000 - SB7FFF	SB0000 - SB7FF0	SB0000 - SB7FFF	SB0000 - SB7FF0		
Timer (Contact)	TS00000-TS25023	-	TS00000-TS32767	-		
Timer (Coil)	TC00000-TC25023	-	TC00000-TC32767	-		
Retentive Timer (Contact)	SS00000-SS25023	-	SS00000-SS32767	-		
Retentive Timer (Coil)	SC00000-SC25023	-	SC00000-SC32767	-		
Counter (Contact)	CS00000-CS25023	-	CS00000-CS32767	-		
Counter (Coil)	CC00000-CC25023	-	CC00000-CC32767	-		
Timer (Current Value)	-	TN00000-TN25023	-	TN00000-TN32767		

Device	First 5 digits of the serial No. in the CPU unit: Less than 10042		First 5 digits of the serial No. in the CPU unit: 10042 or later		32bits	Notes
	Bit Address	Word Address	Bit Address	Word Address		
Retentive Timer (Current Value)	-	SN00000-SN25023	-	SN00000-SN32767	L / H	
Counter (Current Value)	-	CN00000-CN25023	-	CN00000-CN32767		
Data Register / External Data Register ^{*1}	-	D00000-D28159	-	D0000000-D4910079 ^{*2}		 *3
Special Register	-	SD00000-SD2047	-	SD00000-SD2047		 *3
Link Register / External Link Register ^{*4}	-	W00000-W6DFF	-	W0000000-W4AEBFF ^{*2}		 *3
Special Link Register	-	SW00000-SW6DFF	-	SW00000-SW7FFF		 *3
Module Access Device	-----	U000-G00000 - U1FF-G65535	-----	U000-G00000 - U1FF-G65535		 *3 *5
File Register (Normal)	-	R00000-R32767	-	R00000-R32767		 *3 *6
File Register (Block switching is not necessary)	-	ZR00000000-ZR4184063	-	ZR00000000-ZR4849663		 *3 *6
File Register (0R - 31R) ^{*7}	-	0R0000-0R32767	-	0R0000-0R32767		 *3 *6
	-	1R0000-1R32767	-	1R0000-1R32767		
	-	2R0000-2R32767	-	2R0000-2R32767		
	:	:	:	:		
	-	30R0000-30R32767	-	30R0000-30R32767		
	-	31R0000-31R26623	-	31R0000-31R26623		

*1 External Data Register can be used in the CPU of which first 5 digits of serial No. is 09042 or later.

*2 To use addresses D0065536 or higher, or addresses W010000 or higher, the Ethernet interface unit must meet the following requirements:

- The top 5 digits of the serial number are 10042 or later.
- The function version is D or later.

- *3 The access method when specifying bits is different depending on the setting of "Other bits in this word" in "Individual Device Settings".
- [Clear]..... 
- [Do not clear] When bits are written, the Display reads the corresponding word address from the External Device, sets particular bits of that word address to ON, and then returns the resulting address to the External Device. Note that the data may not be written correctly if you write to the word address using the ladder program while the Display is reading data from, and writing data to, the External Device.
- *4 External Link Register can be used in the CPU of which first 5 digits of serial No. is 09042 or later.
- *5 This device enables access of the Buffer Memory of SLMP compatible devices or Intelligent Function Modules. The first 3 digits in the address field specify the start I/O number of the intelligent module.
- *6 It is different by the memory card which uses the range of file register.
- *7 Set the block No. on the head of device name. This is the device name for conversion with GP-Pro/PB III for Windows. When you newly specify the device, we recommend that you should use the file register (Block switching is not necessary).

NOTE

- The notation of addresses differs depending on a selected Unit No.
<Ex.>When 0 is selected for Unit No.,

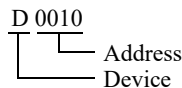



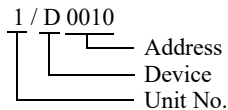















<Ex.>When 1 is selected for Unit No.,

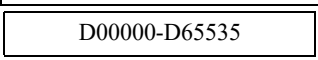

- Please refer to the GP-Pro EX Reference Manual for system data area.
Cf. GP-Pro EX Reference Manual "LS Area (Direct Access Method Area)"
- Please refer to the precautions on manual notation for icons in the table.
 "Manual Symbols and Terminology"

5.3 MELSEC L Series

 This address can be specified as system data area.

Device	Bit Address	Word Address	32 bits	Notes
Input Relay	X0000-X1FFF	X0000-X1FF0	L/H	
Output Relay	Y0000-Y1FFF	Y0000-Y1FF0		
Internal Relay	M00000-M61439	M00000-M61424		
Special Relay	SM0000-SM2047	SM0000-SM2032		
Latch Relay	L00000-L32767	L00000-L32752		
Annunciator	F0000-F32767	F0000-F32752		
Edge Relay	V00000-V32767	V00000-V32752		
Step Relay	S0000-S8191	S0000-S8176		
Link Relay	B0000-BEFFF	B0000-BEFFF0		
Special Link Relay	SB0000-SB7FFF	SB0000-SB7FFF0		
Timer (Contact)	TS00000-TS25471	-----		
Timer (Coil)	TC00000-TC25471	-----		
Retentive Timer (Contact)	SS00000-SS25471	-----		
Retentive Timer (Coil)	SC00000-SC25471	-----		
Counter (Contact)	CS00000-CS25471	-----		
Counter (Coil)	CC00000-CC25471	-----		
Timer (Current Value)	-----	TN00000-TN25471		
Retentive Timer (Current Value)	-----	SN00000-SN25471		
Counter (Current Value)	-----	CN00000-CN25471		
Data Register	-----	 D00000-D65535		 *1
Special Register	-----	SD0000-SD2047		 *1
Link Register	-----	W0000-WFFFF		 *1
Special Link Register	-----	SW0000-SW6FFF		 *1
Module Access Device	-----	U000-G00000 - U1FF-G65535		 *1 *2
File Register (Normal)	-----	R00000-R32767		 *1 *3
File Register (Block switching is not necessary)	-----	ZR0000000-ZR393215		 *1 *3

Device	Bit Address	Word Address	32 bits	Notes
File Register (0R - 11R) ^{*4}	-----	0R00000-0R32767	L/H	Bit F *1 *3
	-----	1R00000-1R32767		
	-----	2R00000-2R32767		
	:	:		
	-----	10R00000-10R32767		
	-----	11R00000-11R32767		

*1 The access method when specifying bits is different depending on the setting of "Other bits in this word" in "Individual Device Settings".

[Clear] **Bit F**

[Do not clear] When bits are written, the Display reads the corresponding word address from the External Device, sets particular bits of that word address to ON, and then returns the resulting address to the External Device. Note that the data may not be written correctly if you write to the word address using the ladder program while the Display is reading data from, and writing data to, the External Device.

*2 This device enables access of the Buffer Memory of SLMP compatible devices or Intelligent Function Modules. The first 3 digits in the address field specify the start I/O number of the intelligent module.

*3 It is different by the memory card which uses the range of file register.

*4 Set the block No. on the head of device name. This is the device name for conversion with GP-Pro/PBIII for Windows. When you newly specify the device, we recommend that you should use the file register (Block switching is not necessary).

















NOTE

- Please refer to the GP-Pro EX Reference Manual for system data area.
Cf. GP-Pro EX Reference Manual "LS Area (Direct Access Method Area)"
- Please refer to the precautions on manual notation for icons in the table.

 "Manual Symbols and Terminology"

5.4 MELSEC iQ-R Series

 This address can be specified as system data area.

Device	Bit Address	Word Address	32 bits	Notes
Input Relay	X0000 - X2FFF	X0000 - X2FF0	L/H	 *1
Output Relay	Y0000 - Y2FFF	Y0000 - Y2FF0		 *1
Internal Relay	M00000000 - M99999999	M00000000 - M99999984		
Special Relay	SM0000 - SM4095	SM0000 - SM4080		
Latch Relay	L00000 - L32767	L000000 - L32752		
Annunciator	F00000 - F32767	F00000 - F32752		
Edge Relay	V00000 - V32767	V00000 - V32752		
Link Relay	B000000 - B9A61FF	B0000000 - B9A61F0		
Special Link Relay	SB000000 - SB9A61FF	SB0000000 - SB9A61F0		
Timer (contact)	TS0000000 - TS8993439	-----		
Timer (coil)	TC0000000 - TC8993439	-----		
Retentive Timer (contact)	SS0000000 - SS8993439	-----		
Retentive Timer (coil)	SC0000000 - SC8993439	-----		
Counter (Contact)	CS0000000 - CS8993439	-----		
Counter (coil)	CC0000000 - CC8993439	-----		
Timer (Current Value)	-----	TN0000000 - TN8993439		
Retentive Timer (Current value)	-----	SN0000000 - SN8993439		
Counter (Current Value)	-----	CN0000000 - CN8993439		
Long Counter (Current Value)	-----	L_CN0000000 - L_CN4761215		
Data Register	-----	D0000000 - D 10117631		 *2
Special Register	-----	SD0000 - SD4095	 *2	
Link Register	-----	W000000 - W9A61FF	 *2	
Special Link Register	-----	SW00000 - SW9A61FF	 *2	
Module Access Device	-----	U000-G00000 - U1FF-G65535	 *2 *3	
File Register	-----	R00000 - R32767	 *2	
File Register (Block switching is not necessary)	-----	ZR0000000 - ZR10027007	 *2	

Device	Bit Address	Word Address	32 bits	Notes
File Register (Up to 1042432 points can be used by block switching)	-----	0R00000 - 0R32767	[L/H]	[Bit F] *2
	-----	1R00000 - 1R32767		
	-----	2R00000 - 2R32767		
	:	:		
	-----	30R00000 - 30R32767		
	-----	31R00000 - 31R32767		

*1 If the CPU is R00CPU/R01CPU/R02CPU, the bit address is "X0000 - X1FFF" and the word address is "X0000 - X1FF0".

*2 The access method when specifying bits is different depending on the setting of "Other bits in this word" in "Individual Device Settings".

[Clear] **[Bit F]**

[Do not clear] When bits are written, the Display reads the corresponding word address from the External Device, sets particular bits of that word address to ON, and then returns the resulting address to the External Device. Note that the data may not be written correctly if you write to the word address using the ladder program while the Display is reading data from, and writing data to, the External Device.

*3 This device enables access of the Buffer Memory of SLMP compatible devices or Intelligent Function Modules. The first 3 digits in the address field specify the start I/O number of the intelligent module.

NOTE

- Please refer to the GP-Pro EX Reference Manual for system data area.
Cf. GP-Pro EX Reference Manual "LS Area (Direct Access Method Area)"
- Please refer to the precautions on manual notation for icons in the table.

 "Manual Symbols and Terminology"

5.5 MELSEC iQ-F Series

 This address can be specified as system data area.

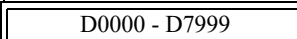
Device	Bit Address	Word Address	32 bits	Notes
Input Relay	X0000 - X1777	X0000 - X1760	L / H	
Output Relay	Y0000 - Y1777	Y0000 - Y1760		
Internal Relay	M00000 - M32767	M00000 - M32752		
Special Relay	SM0000 - SM9999	SM0000 - SM9984		
Latch Relay	L00000 - L32767	L000000 - L32752		
Annunciator	F00000 - F32767	F00000 - F32752		
Step Relay	S0000 - S4095	S0000 - S4080		
Link Relay	B0000 - B7FFF	B0000 - B7FF0		
Special Link Relay	SB0000 - SB7FFF	SB0000 - SB7FF0		
Timer (contact)	TS0000 - TS1023	-----		
Timer (coil)	TC0000 - TC1023	-----		
Retentive Timer (contact)	SS0000 - SS1023	-----		
Retentive Timer (coil)	SC0000 - SC1023	-----		
Counter (Contact)	CS0000 - CS1023	-----		
Counter (coil)	CC0000 - CC1023	-----		
Long Counter (Contact)	L_CS0000 - L_CS1023	-----		*1
Long Counter (coil)	L_CC0000 - L_CC1023	-----		*1
Timer (Current Value)	-----	TN0000 - TN1023		
Retentive Timer (Current value)	-----	SN0000 - SN1023		
Counter (Current Value)	-----	CN0000 - CN1023		
Long Counter (Current Value)	-----	L_CN0000 - L_CN1023		*1
Data Register	-----	 D0000 - D7999		*2
Special Register	-----	SD00000 - SD11999		*2
Link Register	-----	W0000 - W7FFF		*2
Special Link Register	-----	SW0000 - SW7FFF		*2
Module Access Device	-----	U000-G00000 - U1FF-G65535		*2 *3
File Register	-----	R00000 - R32767	*2	

*1 This device can only be used if the Communication Data Code is Binary.

- *2 The access method when specifying bits is different depending on the setting of "Other bits in this word" in "Individual Device Settings".

[Clear] 

[Do not clear] When bits are written, the Display reads the corresponding word address from the External Device, sets particular bits of that word address to ON, and then returns the resulting address to the External Device. Note that the data may not be written correctly if you write to the word address using the ladder program while the Display is reading data from, and writing data to, the External Device.

- *3 This device enables access of the Buffer Memory of SLMP compatible devices or Intelligent Function Modules. The first 3 digits in the address field specify the start I/O number of the intelligent module.

NOTE

- Please refer to the GP-Pro EX Reference Manual for system data area.
Cf. GP-Pro EX Reference Manual "LS Area (Direct Access Method Area)"
- Please refer to the precautions on manual notation for icons in the table.

 "Manual Symbols and Terminology"

6 Device Code and Address Code

Use device code and address code when you select "Device & Address" for the address type in data displays.

6.1 MELSEC Q, QnA, L, iQ-R Series

Device	Device Name	Device Code (HEX)	Address Code
Input Relay	X	0080	Value of word address divided by 0x10
	1/X	0180	
	2/X	0280	
	3/X	0380	
	4/X	0480	
Output Relay	Y	0081	Value of word address divided by 0x10
	1/Y	0181	
	2/Y	0281	
	3/Y	0381	
	4/Y	0481	
Internal Relay	M	0082	Value of word address divided by 16
	1/M	0182	
	2/M	0282	
	3/M	0382	
	4/M	0482	
Special Relay	SM	0083	Value of word address divided by 16
	1/SM	0183	
	2/SM	0283	
	3/SM	0383	
	4/SM	0483	
Latch Relay	L	0084	Value of word address divided by 16
	1/L	0184	
	2/L	0284	
	3/L	0384	
	4/L	0484	

Device	Device Name	Device Code (HEX)	Address Code
Annunciator	F	0085	Value of word address divided by 16
	1/F	0185	
	2/F	0285	
	3/F	0385	
	4/F	0485	
Edge Relay	V	0086	Value of word address divided by 16
	1/V	0186	
	2/V	0286	
	3/V	0386	
	4/V	0486	
Step Relay	S	0087	Value of word address divided by 16
	1/S	0187	
	2/S	0287	
	3/S	0387	
	4/S	0487	
Link Relay	B	0088	Value of word address divided by 0x10
	1/B	0188	
	2/B	0288	
	3/B	0388	
	4/B	0488	
Special Link Relay	SB	0089	Value of word address divided by 0x10
	1/SB	0189	
	2/SB	0289	
	3/SB	0389	
	4/SB	0489	
Timer (Current Value)	TN	0060	Word Address
	1/TN	0160	
	2/TN	0260	
	3/TN	0360	
	4/TN	0460	

Device	Device Name	Device Code (HEX)	Address Code
Retentive Timer (Current Value)	SN	0062	Word Address
	1/SN	0162	
	2/SN	0262	
	3/SN	0362	
	4/SN	0462	
Counter (Current Value)	CN	0061	Word Address
	1/CN	0161	
	2/CN	0261	
	3/CN	0361	
	4/CN	0461	
Long Counter (Current Value)	L_CN	0065	Word Address
	1/L_CN	0165	
	2/L_CN	0265	
	3/L_CN	0365	
	4/L_CN	0465	
Data Register / External Data Register	D	0000	Word Address
	1/D	0100	
	2/D	0200	
	3/D	0300	
	4/D	0400	
Special Register	SD	0001	Word Address
	1/SD	0101	
	2/SD	0201	
	3/SD	0301	
	4/SD	0401	
Link Register / External Link Register	W	0002	Word Address
	1/W	0102	
	2/W	0202	
	3/W	0302	
	4/W	0402	

Device	Device Name	Device Code (HEX)	Address Code
Special Link Register	SW	0003	Word Address
	1/SW	0103	
	2/SW	0203	
	3/SW	0303	
	4/SW	0403	
Module Access Device	U000-G - U1FF-G	0076 - 1F76	Word Address * ¹
File Register (Normal)	R	000F	Word Address
	1/R	010F	
	2/R	020F	
	3/R	030F	
	4/R	040F	
File Register (Block switching is not necessary)	ZR	000E	Word Address
	1/ZR	010E	
	2/ZR	020E	
	3/ZR	030E	
	4/ZR	040E	

Device	Device Name	Device Code (HEX)	Address Code
File Register (0R-31R)	0R	0010	Word Address
	1/0R	0110	
	2/0R	0210	
	3/0R	0310	
	4/0R	0410	
	1R	0011	Word Address
	1/1R	0111	
	2/1R	0211	
	3/1R	0311	
	4/1R	0411	
	2R	0012	Word Address
	1/2R	0112	
	2/2R	0212	
	3/2R	0312	
	4/2R	0412	
	:	:	:
	30R	002E	Word Address
	1/30R	012E	
	2/30R	022E	
	3/30R	032E	
4/30R	042E		
31R	002F	Word Address	
1/31R	012F		
2/31R	022F		
3/31R	032F		
4/31R	042F		

*1 The device name code is specified by the device code and the value of the 28th to 31st bit of the address section. For example, in the case of U1FF-G, the device code is "0x1F76" and the 28th to 31st bits of the address section set to "F".

6.2 MELSEC iQ-F Series

Device	Device Name	Device Code (HEX)	Address Code
Input Relay	X	0080	Value of word address divided by 0x10
Output Relay	Y	0081	Value of word address divided by 0x10
Internal Relay	M	0082	Value of word address divided by 16
Special Relay	SM	0083	Value of word address divided by 16
Latch Relay	L	0084	Value of word address divided by 16
Annunciator	F	0085	Value of word address divided by 16
Step Relay	S	0087	Value of word address divided by 16
Link Relay	B	0088	Value of word address divided by 0x10
Special Link Relay	SB	0089	Value of word address divided by 0x10
Timer(Current Value)	TN	0060	Word Address
Retentive Timer(Current Value)	SN	0062	Word Address
Counter(Current Value)	CN	0061	Word Address
Long Counter(Current Value)	L_CN	0065	Word Address
Data Register	D	0000	Word Address
Special Register	SD	0001	Word Address
Link Register	W	0002	Word Address
Special Link Register	SW	0003	Word Address
Module Access Device	U000-G - U1FF-G	0076 - 1F76	Word Address* ¹
File Register	R	000F	Word Address

*1 The device name code is specified by the device code and the value of bits 28 to 31 of the address portion. For example, for U1FF-G, set the device code to "0x1F76" and set bits 28 to 31 of the address to "F".

7 Error Messages

Error messages are displayed on the screen of Display as follows: "No. : Device Name: Error Message (Error Occurrence Area)". Each description is shown below.

Item	Description
No.	Error No.
Device Name	Name of External Device where error occurs. Device name of External Device is a title of External Device set with GP-Pro EX.(Initial value [PLC1])
Error Message	Displays messages related to the error which occurs.
Error Occurrence Area	<p>Displays IP address or device address of External Device where error occurs, or error codes received from External Device.</p> <p>NOTE</p> <ul style="list-style-type: none"> • IP address is displayed such as "IP address (Decimal): MAC address (Hex)". • Device address is displayed such as "Address: Device address". • Received error codes are displayed such as "Decimal [Hex]".

Display Examples of Error Messages

"RHAA035: PLC1: Error has been responded for device write command (Error Code: 2 [02H])"

NOTE

- Refer to your External Device manual for details on received error codes.
- Refer to "Display-related errors" in "Maintenance/Troubleshooting Guide" for details on the error messages common to the driver.

■ Error Messages Specific to the External Device

Error No.	Message	Description
RHxx128	(Node Name): AGP cannot read or write when "I/O No." and "Station No." are set.	When both "I/O No." and "Station No." in "Request destination module" are set and then access is made to other station, the Display reads or writes data to the Control CPU only in Multiple CPU system.
RHxx129	(Node Name): The specified CPU in the Device Address exceeded the set value of Multiple CPU System. (Address:(Device Address))	The specified CPU No.1 for read or write does not exist.
RHxx130	(Node Name): The specified CPU in the Device Address exceeded the set value of Multiple CPU System. (Address:(Device Address))	The specified CPU No.2 for read or write does not exist.
RHxx131	(Node Name): The specified CPU in the Device Address exceeded the set value of Multiple CPU System. (Address:(Device Address))	The specified CPU No.3 for read or write does not exist.
RHxx132	(Node Name): The specified CPU in the Device Address exceeded the set value of Multiple CPU System.. (Address:(Device Address))	The specified CPU No.4 for read or write does not exist.

